



HAL
open science

Set theory for control applications

Mirko Fiacchini

► **To cite this version:**

Mirko Fiacchini. Set theory for control applications. Dynamical Systems [math.DS]. Université Grenoble Alpes, 2023. tel-04818468

HAL Id: tel-04818468

<https://hal.science/tel-04818468v1>

Submitted on 4 Dec 2024

HAL is a multi-disciplinary open access archive for the deposit and dissemination of scientific research documents, whether they are published or not. The documents may come from teaching and research institutions in France or abroad, or from public or private research centers.

L'archive ouverte pluridisciplinaire **HAL**, est destinée au dépôt et à la diffusion de documents scientifiques de niveau recherche, publiés ou non, émanant des établissements d'enseignement et de recherche français ou étrangers, des laboratoires publics ou privés.

MÉMOIRE DE RECHERCHE

Pour obtenir

L'HABILITATION À DIRIGER LES RECHERCHES DE L'UNIVERSITÉ GRENOBLE ALPES

Spécialité : **Automatique**

Présentée par

Mirko FIACCHINI

préparée au sein du **GIPSA-lab**
et de l'**Ecole Doctorale EEATS**

Set theory for control applications

Soutenue publiquement le ,
devant le jury composé de :

Didier GEORGES

Professeur, Grenoble INP, Président

Franco BLANCHINI

Full professor, University of Udine, Rapporteur

Patrizio COLANERI

Full professor, Politecnico di Milano, Rapporteur

Fabrizio DABBENE

CNR Director of Research, Politecnico di Torino, Rapporteur

Cristina STOICA

Professeur, CentraleSupélec, Paris, Examinatrice

John-Jairo MARTINEZ MOLINA

Professeur, Grenoble INP, Examineur

Sorin OLARU

Professeur, CentraleSupélec, Paris, Examineur



Contents

1	Notation and Acronyms	iii
2	Curriculum Vitae	1
2.1	Scientific research and collaborations	7
2.2	PhD Thesis direction	11
2.3	Scientific diffusion and management	12
2.4	List of publications	16
3	Scientific production	23
3.1	Research lines	24
3.1.1	Stabilizability of switched systems	24
3.1.2	Systems with aperiodic sampling and saturation	26
3.1.3	Model predictive control and invariance	27
3.1.4	Modeling and control for cancer dynamics	29
3.1.5	Anesthesia monitoring	29
3.1.6	Modeling and control for aluminium production	30
3.1.7	Data and learning for control	31
3.1.8	Functional observers for discrete-time LPV systems	32
3.1.9	Decentralized systems	33
3.1.10	Hybrid systems with saturation	33
3.1.11	Unknown input observer for uncertain systems	34
3.2	Conclusions	34
4	Invariant set computation	35
4.1	Control invariant sets in high dimension	36
4.1.1	N-step condition for control invariance	38
4.1.2	State inclusion test	40
4.1.3	Numerical examples	41
4.2	Probabilistic invariance	43
4.2.1	Correlation bound	44
4.2.2	Probabilistic reachable and invariant sets	46
4.2.3	Numerical examples	48
4.3	Conclusions	50
5	Stabilizability of switched systems	51
5.1	Stabilizability of switched systems	52
5.2	Necessary and sufficient condition	54
5.2.1	Duality robustness-control of switched systems	55
5.2.2	Switching control law	56
5.3	Sufficient conditions and comparisons	60
5.3.1	Lyapunov-Metzler BMI conditions	60
5.3.2	LMI sufficient condition	63
5.3.3	Stabilizability conditions relations	65
5.4	Computation-oriented condition	69
5.4.1	Conic partition and nonnegative quadratic forms	70
5.4.2	Local contraction constraint and algorithm	72

5.5	Control co-design	75
5.5.1	Switching law and feedback control co-design	75
5.5.2	Comparisons	78
5.6	Conclusions	80
6	Aperiodic sampled-data systems	83
6.1	Saturated aperiodically sampled systems	84
6.2	Ellipsoidal sets and quadratic functions	86
6.2.1	Convex conditions for stability and control	86
6.3	Polyhedral sets	90
6.3.1	Outer approximations	92
6.3.2	Inner approximations	94
6.4	Conclusions	100
7	Conclusions and Perspectives	101
7.1	Stochastic systems	102
7.1.1	Stochastic invariance and MPC	102
7.1.2	Stochastic switched systems	103
7.1.3	Stochastic aperiodic sampling	104
7.2	Control and learning applications	106
7.2.1	Anesthesia monitoring	106
7.2.2	Anode effect predictor for aluminium production	109
7.2.3	Privacy preservation of mobility data	111
	Bibliography	113

Notation and Acronyms

Notation

Define with \mathbb{R} the set of real numbers, with \mathbb{R}_+ the set of nonnegative real numbers and with \mathbb{N} the set of natural ones. Given $n \in \mathbb{N}$, define $\mathbb{N}_n = \{x \in \mathbb{N} : 1 \leq x \leq n\}$.

Matrices and vectors: The subindex denotes, with slight abuse of notation, both the i -th row of a matrix (or a vector) and the i -th element of a countable set of elements. When ambiguity can raise the i -th row of matrix A is denoted $A_{(i)}$, $A^{(i)}$ is its i -th column and $M_{(i,j)}$ its (i,j) -entry. M^T is the transpose of $A \in \mathbb{R}^{n \times m}$ and $\|A\|$ is its induced 2-norm. For $x \in \mathbb{R}^n$, $\|x\|$ is its Euclidean norm. For $A \in \mathbb{R}^{n \times m}$, $\|A\| = \sigma_{max}(A)$ is its induced 2-norm (largest singular value) and $\sigma_{min}(A)$ is its smallest singular value. If A is symmetric then $\sigma_{max}(A)$ is its maximum eigenvalue. Given a symmetric matrix A , notation $A \succ 0$ ($A \succeq 0$) denote that A is positive (semi-)definite, analogously for negative (semi-)definiteness. The symbols $\leq, <, >$ and \geq applied to matrices and vectors denoted element-wise ordering. The symbol 0 denotes, besides the zero, also the matrices of appropriate dimensions whose entries are zeros and the origin of a vectorial space, its meaning being determined by the context. The symbol $\mathbf{1}$ denotes the vector of entries 1 and I the identity matrix, their dimension is determined by the context. The set of Metzler matrices of dimension N , i.e. matrices $\pi \in \mathbb{R}^{N \times N}$ whose elements are nonnegative and $\sum_{j=1}^N \pi_{ji} = 1$ for all $i \in \mathbb{N}_N$, is denoted is \mathcal{M}_N . Denote with e_k the k -th canonical base vector of the Euclidean space and $\mathbf{1} = [1 \dots 1]^T$.

Sets: Given $D, E \subseteq \mathbb{R}^n$, $\alpha \in \mathbb{R}$ and $M \in \mathbb{R}^{m \times n}$, define $D + E = \{z = x + y \in \mathbb{R}^n : x \in D, y \in E\}$, the scalar multiple $\alpha D = \{\alpha x \in \mathbb{R}^n : x \in D\}$ and $MD = \{Mx \in \mathbb{R}^m : x \in D\}$. Given a set $D \subseteq \mathbb{R}^n$, $\text{int}(D)$ is its interior and ∂D its boundary, $\text{co}(D)$ is its convex hull. The unit ball in \mathbb{R}^n is \mathcal{B}^n and the unit box is \mathbb{B}^n , the subscript n being dropped when clear from the context, i.e. $\mathcal{B} = \mathcal{B}^n = \{x \in \mathbb{R}^n : x^T x \leq 1\}$ and $\mathbb{B} = \mathbb{B}^n = \{x \in \mathbb{R}^n : \|x\|_1 \leq 1\}$. Given $m \in \mathbb{N}$ denote with $2^{\mathbb{N}^m}$ the set of all subsets of \mathbb{N}_m . The set D is C^* -set if it is compact, star-convex with respect to the origin and contains the origin in its interior; it is a C -set if moreover it is convex. Given $P \in \mathbb{R}^{n \times n}$ with $P \succ 0$, define $\mathcal{E}(P) = \{x \in \mathbb{R}^n : x^T P x \leq 1\}$. The simplex in \mathbb{R}^n is denoted as ∇^n , that is $\nabla^n = \{\mu \in \mathbb{R}^n : \mu \geq 0, \sum_{i=1}^n \mu_i = 1\}$. The sets $\{\Gamma_i\}_{i \in \mathbb{N}_p}$ are a cover of \mathbb{R}^n if $\bigcup_{i \in \mathbb{N}_p} \Gamma_i = \mathbb{R}^n$. Denote as $\mathcal{P}(H, h) = \{x \in \mathbb{R}^n : Hx \leq h\}$ with $H \in \mathbb{R}^{n_h \times n}$ and $h \in \mathbb{R}^{n_h}$, the H -representation of a polyhedron.

Functions: For any function $f : \mathbb{R} \rightarrow \mathbb{R}^n$ we denote $f(t^-) = \lim_{\tau \rightarrow t, \tau < t} f(\tau)$ if the limit exists and similarly for $f(t^+)$. The components of the saturation function $\text{sat}(v) : \mathbb{R}^m \rightarrow \mathbb{R}^m$ are defined as $\text{sat}_{(r)}(v) = \text{sign}(v_{(r)}) \min\{|v_{(r)}|, 1\}$, $r \in \mathbb{N}_m$.

Modes and sequences: The q modes of the switched systems are denoted by \mathcal{I} , that is $\mathcal{I} = \mathbb{N}_q$; $\mathcal{I}^k = \prod_{j=1}^k \mathcal{I}$ are all the possible sequences of modes of length k and $\mathcal{I}^{[M:N]} = \bigcup_{k=M}^N \mathcal{I}^k$ those of length from M to N . The number of elements $i \in \mathcal{I}^{[1:N]}$ are $\bar{N} = \sum_{k=1}^N q^k$, analogous definition holds for \bar{M} . Given $i = (i_1, \dots, i_k)$ such that $i \in \mathcal{I}^{[1:N]}$ and a set Ω , define $\mathbb{A}_i = \prod_{j=1}^k A_{i_j} = A_{i_k} \cdots A_{i_1}$, $\Omega_i = \Omega_i(\Omega) = \{x \in \mathbb{R}^n : \mathbb{A}_i x \in \Omega\}$ and $\mathcal{B}_i = \{x \in \mathbb{R}^n : x^T \mathbb{A}_i^T \mathbb{A}_i x \leq 1\}$; then $\mathcal{B}_i = \Omega_i(\mathcal{B}^n)$. The dependence of Ω_i on Ω is omitted when clear from the context.

List of Acronyms

- LMI: Linear Matrix Inequality
- BMI: Bilinear Matrix Inequality
- RAO: Region of Attraction of the Origin
- MPC: Model Predictive Control
- SMPC: Stochastic Model Predictive Control
- LQR: Linear Quadratic Regulator
- ACD: Anode-Cathode Distance
- UIO: Unknown Input Observer
- SNS: Saturated and NonSaturated
- LP: Linear Programming

Curriculum Vitae

Mirko FIACCHINI

Chargé de recherche CRCN CNRS at GIPSA-lab, Grenoble

Born on 22 July 1977 at Vinci (Italy)

Nationalities : Italian, French

Professional address :

GIPSA-lab,
11 rue des Mathématiques,
Grenoble Campus BP46,
F-38402 Saint Martin D'Hères Cedex.

E-mail : mirko.fiacchini@gipsa-lab.fr

Tel : +33 (0)4 76 82 62 25

Formation and training

11/2012-Today : **Chargé de recherche CNRS at GIPSA-lab Grenoble** on set-theoretic based control, invariance, hybrid and saturated systems, biological systems.

10/2011-09/2012 : **Post-doct at CRAN Nancy** on the application of the set theory for control and predictive control, directed by G. Millerioux.

02/2010-09/2011 : **Post-doct at LAAS-CNRS Toulouse** on the control for hybrid and saturated systems, directed by C. Prieur and S. Tarbouriech.

2006-01/2010 : **PhD thesis on Automatic control** obtained at Dpt. of Systems and Automatics of the University of Seville, Spain. 11 January 2010.

Title : Convex Difference Inclusions for Systems Analysis and Design

Directors : Eduardo Fernandez Camacho and Teodoro Alamo.

2007-2008 : (*1 year*) : visiting student at the **Institute for Automatics** directed by M. Morari, ETH Zurich, Switzerland.

2004-2006 : **Diploma de Estudios Avanzados (DEA) in Automatics and Robotics** delivered by the University of Seville, Spain.

1996-2004 : **Laurea degree in Computer science** (speciality Automatics and industrial automation systems), delivered by the University of Florence, Italy.

2003-2004 : (1 year) : Participation to the international program **ERASMUS** at Seville, Spain, in the group direct by E.F. Camacho, of the Dpt. of Systems and Automatics.

Scientific production

41 publications in peer-review international journals (*IEEE Transactions on Automatic Control, Automatica, SIAM Journal on Control and Optimization, Systems and Control Letters, etc.*);

4 book chapters for *Springer and ISTE Ltd and John Wiley & Sons Inc.*;

51 publications in peer-review international conferences (*CDC, ECC, ACC, IFAC, Rocond, etc.*);

3 publications in national Spanish conferences (*JA05, JA06*).

Teaching

Lecturer and responsible of:

Master 2 course *Optimization and Optimal control*, at the Université Joseph Fourier / Université Grenoble Alpes, Grenoble, 2013-2014 and 2019-2023.

Master 1 course *Linear Optimal Control*, at the Université Grenoble Alpes, Grenoble, 2022-2023.

Master 1 course *Feedback Control for SISO Systems*, at the Université Joseph Fourier / Université Grenoble Alpes, Grenoble, 2013-2019.

Responsible of the Master 2 MISCIT internships program, Université Joseph Fourier, Grenoble, 2013-2014.

Assistant lecturer

2016-2023: 1st year course *Projet G5: Régulation de niveau/débit dans un système d'irrigation*, at the INP of Grenoble (ENSE3) / Université Grenoble Alpes, Grenoble.

2011-2013 : Assistant lecturer at: INSA, ISAE and Université Paul Sabatier of Toulouse; ESSTIN of Nancy; ENSE3 of Grenoble;

2006-2009 : Assistant lecturer at the University of Seville, Spain.

Director of one Master 2 internship at the Université Grenoble Alpes, Grenoble, 2021.

Director of two Master 1 internships at the Université Grenoble Alpes, Grenoble, 2018.

Director of two Master 1 internships at the University Toulouse III - Paul Sabatier (UPS), 2011.

Thesis and post-doc direction

PhD thesis

11/2021-10/2024 **Bob Auboin-Pairault** (50% with Thao Dang) on *Data-based anesthesia process modelling for online monitoring and prediction*, funded by PERSYVAL-lab.

03/2019-12/2022 **Daniel Denardi Huff** (50% with J.M. Gomes da Silva Jr.) on *Optimization-based Control of Aperiodically Sampled Saturated Systems*, funded by IDEX UGA and CAPES Brazilian scholarship.

12/2018-03/2022 **Lucas José da Silva Moreira** (33% with G. Besançon and F. Ferrante) on *Modélisation et commande multivariables pour la production d'aluminium*, funded by FUI.

10/2017-11/2020 **Kaouther Moussa** (70% with M. Alamir) on *Domain of attraction estimation and optimization-based control: Application to tumor growth models*, doctoral school EEATS.

10/2013-11/2016 **Rachid Riah** (50% with M. Alamir) on *Théorie des ensembles pour le contrôle robuste des systèmes non linéaires: Application à la chimiothérapie et les thérapies antiangiogéniques*, doctoral school EEATS.

Post-docts

11/2022-10/2024 **Andrea Mattioni** (with G. Besançon) on *anode effect prediction in the aluminum production process*, funded by "Plan de relance CNRS" and Rio Tinto.

10/2022-09/2023 **Emilio Jesús Molina Olivares** (with S. Cerf and B. Robu) on *protecting privacy in mobile apps using predictive control and machine learning techniques*, funded by MIAI project AIBot.

07/2022-06/2023 **Himadri Basu** (with F. Ferrante) on *stochastic and network hybrid systems*, funded by ANR project HANDY.

02/2017-10/2017 **Rachid Riah** (with M. Alamir) on *distributed control design and optimization for a tidal farm system*, funded by ADEME project PRISMER.

02/2016-12/2016 **Miguel Angel Davo Navarro** (with C. Prieur) on *event-triggered control for nonlinear systems*, funded by ANR project LimCoS.

12/2015-11/2016 **Sofiane Ben Chabane** (with M. Alamir) on *distributed control design and optimization for a tidal farm system*, funded by ADEME project PRISMER.

Research projects

Institutional and industrial projects **management**:

Scientific coordinator of **LabEx PERSYVAL-Lab “équipe-actions”** project DAMon (Data-based Anesthesia Monitoring) 2021-2024. Funds: **180k€**.

GIPSA-lab responsible of the industrial collaboration contract with **Rio Tinto**, 2022-2024. Partners: Aluminium pechiney (Rio Tinto Group), GIPSA-Lab. Cofunded by CNRS (“Plan de relance 2022”). Funds: **155k€**

GIPSA-lab co-responsible of the industrial collaboration contract with **Rio Tinto**, 2018-2022. Partners: Aluminium pechiney (Rio Tinto Group), GIPSA-Lab. Cofunded by BPI. Funds: **132k€**

GIPSA-lab responsible of the industrial collaboration contract with **CALOR ent. (SEB group)**, 2018-2020. Partners: CALOR ent., GIPSA-Lab. Funds: **22.5k€**

Unit leader of **LabEx PERSYVAL-lab exploratory project** (Set Theory and Alg. for Dyn. Syst.), 2014-2015. Funds: **10k€**.

Projects **participation**:

HANDY (Hybrid And Networked Dynamical sYstems) funded by ANR 2019-2023.

PIANO (Piloteage individuel des anodes), funded by FUI, 2018-2021. Partners: Aluminium pechiney (Groupe Rio Tinto, coordinator), Centralp, GIPSA-Lab.

CompACS (Computation Aware Control Systems) funded by ANR and FRAE, 2013-2017.

PRISMER (Intercon. électr. hydroliennes et export électr. ferme), funded by ADEME, 2013-2017.

LimICoS (Synthèse et analyse des systèmes avec informations limitées) funded by ANR, 2012-2016.

CATS (Computer-Assisted Therapeutic Strategies), funded by INSERM, 2013-2016.

ArHyCo (Architectures Hybrides et Contraintes) funded by ANR, 2009-2012.

Editorial and organization activity

Head of the group *MODUS* of GIPSA-lab, from 2020.

Vice-head (*adjoint*) of the group *SYSCO* of GIPSA-lab, 2014-2019.

International Program Committee member for the CDC22.

International Program Committee member for the ROCOND2022.

Scientific co-Chair of the 41st Int. Summer School of Automatic Control, Grenoble, September 2021.

Associate Editor for the 21st IFAC World Congress 2020.

Associate Editor in the Conference Editorial Board of the IEEE CSS since 2017.

Associate Editor in the Conference Editorial Board of the European Control Conference ECC since 2021.

Local Organizer of the Int. Summer School of Automatic Control, Grenoble, since 2018.

Publication Chair and NOC member of the 1st *IFAC LPVS* workshop, Grenoble, October 2015.

Co-organizer of the 1st *Journées de l'Automatique GDR MACS*, Grenoble, October 2015.

Scientific co-Chair of the 35th Int. Summer School of Automatic Control, Grenoble, September 2014.

Member of the *IFAC Technical Committee 2.5 on Robust Control*, since 2015.

International Program Committee member for the ECC15.

Associate Editor for IMA Journal of Mathematical Control and Information, 2014-2015.

Reviewer for several international journals (IEEE TAC, Automatica, etc.) and several international conferences (CDC, ACC, ECC, IFAC-WC, etc).

Research interests

Set-theory and invariance: Set-theoretic methods, invariance and contractivity for nonlinear systems. Estimation of the domain of attraction. Set-induced Lyapunov functions. Probabilistic invariant and reachable sets.

Switched systems: Quadratic stability analysis of switched systems. Stabilizability and nonconvex Lyapunov functions for discrete-time switched linear systems.

Aperiodic sampling: Stability and stabilization of linear systems with aperiodic sampling. Presence of saturation. Stochastic aperiodic sampling.

Saturated systems: Convex set-induced Lyapunov functions for saturated systems. Sufficient and necessary conditions for convergence based on convex analysis.

Optimal and Predictive control: Design of predictive and optimal control strategies. Applications to mobile vehicles, aluminum production and biological systems. Stochastic MPC.

Biological systems: Control-based methods for chemo and immunotherapy design for tumor growth models. Modelling and control of the anesthesia process.

Learning for control: Application of machine learning techniques to control design and estimation of dynamical systems.

2.1 Scientific research and collaborations

The main topics to which my research activity has been directed are set-theoretic methods for control and systems analysis, from both the theoretical and the applicative points of view. The attention has been devoted to discrete-time systems, in presence of uncertainty as well as for the deterministic case, but also to nonlinear and hybrid systems.

In general, set-theoretic methods refer to those techniques concerning properties shared by all the elements of sets of the state space. A particularly important example in the field of dynamical systems and control design involving set-theoretic methods is represented by invariance.

An invariant set, for a given dynamical system, is a region of the state space such that the trajectory generated by the system remains confined in the set if the initial condition lies within it, see [Blanchini and Miani, 2008]. The concept of invariance has become fundamental for the analysis and design of control systems. Although many research efforts have been directed to related themes throughout the whole second half of the last century, see [Gutman and Cwikel, 1986a, Gutman and Cwikel, 1987, Gilbert and Tan, 1991, Blanchini, 1994, Blanchini, 1995] and [Kolmanovsky and Gilbert, 1998a, Blanchini, 1999], the field became particularly active in the last years. The importance of invariant sets in control is due to the implicit stability properties of these regions of the state space. Set-theory and invariance have strong theoretical relations with the following classical topics in the field of control and dynamical systems analysis: hard constraints satisfaction; stability analysis; computation and estimation of domains of attraction; Lyapunov functions and convergence; Model Predictive Control.

Moreover, a tight link exists with optimization, which makes set-theory methods particularly suitable to be applied to practical problems. These methods and techniques, well established in the context of linear systems, are the basis for dealing with problem of control for more complex families of systems, such as nonlinear, hybrid, switched, stochastic, distributed etc. This has been the idea underlining my recent research.

Invariance and Predictive control

Model Predictive Control (MPC) has been well-admitted, for the past 50 years, as a suitable solution to deal with multi-variable constrained control problems, [Mayne et al., 2000, Bemporad and Morari, 1999, Camacho and Alba, 2013, Kouvaritakis and Cannon, 2016]. Concerning the problem of convergence of MPC strategies, those based on invariant sets as terminal constraint are possibly the most popular. Indeed, the strategies based on invariant sets allow to guarantee convergence towards the origin by implicitly extending the prediction horizon to the infinity without any substantial increasing of the on-line computational cost. The computation of the invariant sets which are usually polytopes or ellipsoids, is performed off-line [Gilbert and Tan, 1991, Kolmanovsky and Gilbert, 1998a, Blanchini and Miani, 2008].

Considering time-varying constraints led to a research line, developed in collaboration with **G. Millerioux, T. Chambrion and T. Manrique, of CRAN, Nancy**, yielding to contributions on the computation of the invariant set in presence of time-varying constraints, appeared in [Manrique et al., 2013, Manrique et al., 2014, Manrique et al., 2015]. Moreover, the problem of efficient computing control invariant polyhedra led to the publication of works [Fiacchini and Alamir, 2017a, Fiacchini and Alamir, 2018a], together with **M. Alamir, GIPSA-lab**. Finally, on this topic, the characterization of probabilistic reachable sets and probabilistic invariant sets, key ingredient for stochastic MPC feasibility and

convergence, has been published in [Chaouach et al., 2022, Fiacchini and Alamo, 2020], in the framework of the collaboration with **L. Chaouach, TU Delft**, and **T. Alamo, University of Seville**.

Stabilizability of switched systems

Switched systems are characterized by dynamics that may change along the time among a finite number of possible dynamical behaviors, see [Liberzon, 2003]. The problem of stability or stabilizability, depending on the assumption on the switching law, of linear switched system attracted many research efforts, see the overview [Lin and Antsaklis, 2009] and the monograph [Sun and Ge, 2011]. The problem addressed in this research line, resulting from a collaboration with **M. Jungers and G. Millerioux of CRAN, Nancy** with **A. Girard, of L2S, Paris** and **S. Tarbouriech of LAAS, Toulouse**, has been the problem of stabilizability of switched linear systems, namely the condition under which a switching law can be designed for the system to be asymptotically stable. This research line led to several publications: [Fiacchini and Jungers, 2014, Fiacchini et al., 2016a, Fiacchini et al., 2016b, Fiacchini et al., 2018, Fiacchini and Millérioux, 2017, Fiacchini and Tarbouriech, 2017] and also [Fiacchini and Millérioux, 2018, Fiacchini, 2021].

Stability of systems under aperiodic sampling and saturation

This research line concerns the problem of stability of sampled-data controlled linear systems under aperiodic sampling and subject to input saturation. These phenomena are tightly related to real systems, as almost ubiquitous when digital devices are involved, the called cyber-physical systems. Motivated by the implementation of digital control loops over networks (networked control) [Zhang et al., 2001], indeed, the study of sampled-data control under aperiodic sampling has been the focus of new results in the field. Moreover, static nonlinearity like saturation [Tarbouriech et al., 2011] are often unavoidable in practice.

Results have been obtained on this research line, shared with **J.M. Gomes da Silva Jr. from UFRGS, Brazil**, that led to novel constructive approaches to test the stability and stabilizability of sampled-data controlled linear systems under aperiodic sampling and saturating input, [Fiacchini and Morărescu, 2014b, Fiacchini and Gomes da Silva Jr., 2018] [Fiacchini et al., 2016a, Denardi Huff et al., 2022b, Denardi Huff et al., 2022a] and in papers [Denardi Huff et al., 2022, Denardi Huff et al., 2022]. The research has been developed in the thesis of **Daniel Denardi Huff**, co-funded by the the IDEX UGA and the Brazilian COPES in the framework of an international cooperation project.

Saturated systems

In the last decades, the stability of linear system subject to actuator saturation attracted a big interest. There are many researchers working on this topic currently, [Hu and Lin, 2002, Alamo et al., 2005, Tarbouriech et al., 2011]. This research line, developed in collaboration with **S. Tarbouriech, LAAS, Toulouse** and **C. Prieur and R. Riah, GIPSA-lab, Grenoble** led to the characterization of computationally affordable conditions for invariance of sets for discrete-time saturated systems, published in [Fiacchini et al., 2014a, Riah and Fiacchini, 2015].

Modeling and control-based therapy for cancer dynamics

Modeling the dynamics underlying the tumor growth and the related mechanisms such as the tumor-induced vascular development, i.e. the angiogenesis, is a key step towards rational optimization of cancer therapy. Several mathematical models representing the tumor evolution and the induced angiogenesis appeared in the last decades. In particular, the works [Hahnfeldt et al., 1999, Ergun et al., 2003, d’Onofrio et al., 2009] provide population based models consisting in low-dimensional systems that permit to reproduce qualitatively the evolution of the tumoral mass and its vascularization.

The application of dynamic systems and control for cancer modelling and therapy design, started in collaboration with **M. Alamir, of GIPSA-lab** and **A. Stéphanou, of TIMC-IMAG, Grenoble** and developed in the framework of two PhD thesis, **R. Riah**, and **K. Moussa**, led to several results published in [Alamir et al., 2015, Riah et al., 2015, Riah et al., 2016, Riah, 2016, Moussa et al., 2019, Moussa et al., 2020]. In these works, set-theory and optimization-based techniques have been applied to infer the domain of attraction and then robust control for the uncertain models of cancer.

Anesthesia

This project started with the collaboration with **S. Tarbouriech and I. Queinnec, of LAAS-CNRS, Toulouse**, and **M. Alamir, of GIPSA-lab**, as a result of the contact with the anesthesiologist, **M. Mazerolles of CHU Toulouse**. In medical practice, anesthesia typically considers the administering of hypnotic and analgesic drugs monitored by the anesthetist by examining reliable indicators, as in particular the bispectral index (BIS). The problem consists in practice in designing a control-based drug deliverance protocol to lead the patient to a desired sleep depth as soon as possible but avoiding dangerous drug concentrations. Several approaches have been proposed in the literature, from simple PI control to more complex adaptive control strategies [Bailey and Haddad, 2005, Lemos et al., 2014, Beck, 2015, Zabi et al., 2015, Ionescu et al., 2008] and some of them have been clinically validated [van Heusden et al., 2014, Absalom and Kenny, 2003].

On this topic, we have been working to design a control based on set theory and in particular on invariant sets, which allows ensuring that the evolution of a system can be indefinitely maintained within a given set of the state space, see [Fiacchini et al., 2016c]. Moreover, a robust control strategy for guiding the anesthesia has been designed for the specific problem by supposing that the system dynamics are poorly known and strongly affected by parameter uncertainties, that is a realistic assumption. The results have been published in [Alamir et al., 2018]. This research line is still very active, being the object of the research project DAMon, started in 2021.

Modeling and control for aluminium production

Aluminum manufacturing is a challenging industrial area based on the Hall-Heroult process [Grjotheim, 1982]. In this setting, model and control challenges arise from the limitations in the process information continuously available, which can lead to inaccurate results [Jakobsen et al., 2001]. We have been addressing the problem of modelling and controlling the Hall-Heroult process, together with **G. Besançon and F. Ferrante, of GIPSA-lab**, in a FUI project coordinated by RioTinto. The FUI project includes the funding for a thesis, provided to **Lucas José da Silva Moreira**, and a parallel three-years-lasting contract between GIPSA and RioTinto to fund this research line. Results on this ongoing research line have been published in [da Silva Moreira et al., 2020a, da Silva Moreira et al., 2020b,

da Silva Moreira et al., 2020c, Moreira et al., 2021] and [da Silva Moreira et al., 2022]. This research activity is currently directed to the study of anode affects, in the framework of a project started in late 2022.

Machine learning for control and estimation

A research line on which I started recently working, but that I think will deserve several of my attentions in the near future, concerns the application and exploitation of regression and classification methods based on machine learning approaches in the context of control of dynamical systems. In the paper [Gonzalez et al., 2018] we have been investigating on the capability of estimating and predicting the slippage associated with individual wheels in off-road mobile robots. Also in the work done in the framework of the industrial project with CALOR ent., the methods based on machine learning have been one of the key approaches to address and solve the observation and control problem. Machine learning and data-based approaches are also currently employed for modelling and events detection in the framework of the anesthesia monitoring project DAMon I am leading.

2.1.0.1 Unknown input observer design for uncertain systems

A side research line concerned the design of unknown input observer for uncertain systems. This line has been developed in the framework of the collaboration with **Iman Hosseini**, PhD student at the **University of Shiraz, Iran**, that has been visiting GIPSA-lab during around one year, in 2018, under my direction. With Iman, we have been proposing a novel kind of Unknown Input Observer (UIO) called Reset Unknown Input Observer (R-UIO) for state estimation of linear and nonlinear systems in the presence of disturbance using Linear Matrix Inequality (LMI) techniques, [Hosseini et al., 2019b, Hosseini et al., 2019a]

2.1.0.2 Decentralized systems

This research line concerns the decentralized control for multi-agent systems and consensus problems. Several works on this topic have been oriented towards the connectivity preservation of the interconnection graph of mobile networks [Bullo et al., 2009, Zavlanos and Pappas, 2008]. To deal with the problem of graph preservation in multi-agent systems, with **C. Morarescu, of CRAN, Nancy**, we presented conditions for network topology preservation, see [Fiacchini and Morărescu, 2012, Fiacchini and Morărescu, 2014a, Morărescu and Fiacchini, 2014, Morărescu and Fiacchini, 2016]. The main contribution of this research line is the characterization of the control laws preserving a given graph by using methods from set-theoretic and invariance techniques.

2.2 PhD Thesis direction

Bob Auboin-Pairault 11/2021-10/2024 (50% with Thao Dang) on *Data-based anesthesia process modelling for online monitoring and prediction*, funded by PERSYVAL-lab.

The objective of the PhD thesis of Bob is to apply analytical and data-based methods of advanced control theory, machine learning and optimization to the problems of modelling, monitoring and controlling the anesthetic process. Particular attention is devoted to the unavoidable uncertain nature and variability of the dynamics involved in the process of the anesthesia regulation. This PhD thesis is developed in the framework of an interdisciplinary project that gathers researchers from different fields to contribute to a deeper understanding of the dynamics involved in the anesthesia process and to design ad-hoc methods for analysis and control synthesis, based on the available real anesthesia data.

Daniel Denardi Huff 03/2019-12/2022 (50% with J.M. Gomes da Silva Jr.) on the *Optimization-based Control of Aperiodically Sampled Saturated Systems*, funded by IDEX UGA and CAPES Brazilian scholarship.

The fundamental problem concerning the characterization of stability analysis and control design, based on set theory constructive conditions, for systems affected by aperiodic sampling and saturated actuators has been considered in Daniel's PhD. The analysis has been also extended to the case of stochastic nature of the aperiodic sampling, modelled by a Poisson process. In this context, more general stochastic processes and also the presence of the saturation on the input value are being taken into account to estimate region of attraction and characterize the mean exponential stability of the closed loop. Particular interest has been devoted to the practical computational aspects, with the objective of implementing the algorithms and the optimization-based controls stemming from the theoretical results. Several publications have appeared, see [Fiacchini and Gomes da Silva Jr., 2018, Denardi Huff et al., 2022b, Denardi Huff et al., 2022a, Denardi Huff et al., 2021] and [Denardi Huff et al., 2022].

Lucas José da Silva Moreira 12/2018-02/2022 (33% with G. Besançon and F. Ferrante) on *Modélisation et commande multivariables pour la production d'aluminium*. FUI funds.

Aluminum manufacturing is a challenging industrial area, mostly based on alumina electrolysis, a process that is highly demanding in electrical power. In particular, alumina electrolysis typically relies on a series of electrolytic cells. Such cells are composed by a bath containing alumina in which a set of anodes is dipped. The base of each cell plays the role of the cathodic electrode in the electrolysis process. In this process, energy consumption mostly depends on the anode-cathode relative distance. However, such a distance cannot be measured. The main purpose of this PhD thesis was to study, design, and test multivariable feedback control laws to optimally regulate the anode-cathode relative distance. The project was organized in three different stages: dynamical modeling and identification, control and observer design, experimental validation and tuning. Lucas' work mostly took place at GIPSA-lab, in collaboration with Rio Tinto Alcan (RTA). Experimental activities have been conducted at the RTA research center in Saint-Jean de Maurienne. The thesis led to the publication in international conferences [da Silva Moreira et al., 2020a, da Silva Moreira et al., 2020c, Moreira et al., 2021] and the

international journal paper [da Silva Moreira et al., 2022].

Kaouther Moussa 10/2017-09/2020 (70% with M. Alamir) *Domain of attraction estimation and optimization-based control: Application to tumor growth models*. Doctoral school EEATS.

The problem of characterizing the regions of stability and convergence, i.e. the domains of attraction, underlies most of the results in control theory, as stability and convergence are usually essential properties of a control law. The main objective of the PhD thesis was to apply the methods based on non-convex optimization for computing the domain of attraction for nonlinear systems to validate or design a cancer therapy. As for many biological models, cancer models are to be considered as affected by important uncertainties, since the parameters of the models are often unknown and strongly patient-dependent and the system state is usually not known exactly. The thesis aimed at proposing methods to verify the effectiveness of a given therapeutic profile or to design an appropriate therapy, by explicitly taking into account the uncertainties and the nonlinearities of the models. The thesis led to the publications in international conferences [Moussa et al., 2019, Moussa et al., 2020] and in international journals [Moussa et al., 2021, Moussa et al., 2022].

Rachid Riah 10/2013-11/2016 (50% with M. Alamir) *Théorie des ensembles pour le contrôle robuste des systèmes non linéaires : Application à la chimiothérapie et les thérapies anti-angiogéniques*. Doctoral school EEATS

The thesis concerned the mathematical modeling of brain tumor dynamics and the design of control-based chemo and immunotherapy. In terms of control, the aim was to characterize the domains of attraction of any equilibrium, related to sane or insane evolutions of the tumor, and the reachable sets from every particular initial condition as functions of the control input. This permitted to characterize the set of tumor initial conditions from which a healthy equilibrium can be reached as well as to design the therapy which maximizes the effectiveness while minimizing the negative side-effects. The presence of model uncertainty and nonlinearities have been considered, since inherent to the real problem affecting biological systems. The thesis [Riah, 2016] led also to the publications in international conferences and journal [Riah and Fiacchini, 2015, Riah et al., 2015, Riah et al., 2016, Riah et al., 2019].

2.3 Scientific diffusion and management

Conferences and workshops

In the last years, I have been involved in the organization of the events listed below.

Scientific co-Chair of the of the 41st Int. Summer School of Automatic Control, Grenoble, September 2021, titled *Data and Learning or Control*, on learning methods and data-based tools for control applications.

Publication Chair of the 1st IFAC Workshop on Linear Parameter Varying Systems, 2015. I have been also in the organization committee of this workshop, held in 10/2015, and whose general and NOC chair was **O. Sename, of GIPSA-lab**.

Co-organizer of the 1st edition of the “Journées de l’Automatique GDR MACS”, organized to gather the members of the different GT du GDR MACS, that is a CNRS structure for the scientific animation of the French communities of automatic control and industrial automation. The event has been held in Grenoble, in 10/2015.

International Program Committee member for the European Control Conference 2015, the Conference on Decision Control 2022 and IFAC ROCOND 2022. My task as IPC member was to provide my expertise in the field of set-theoretic based and optimization based control to evaluate some of the submitted papers, the final decision on which was still pending after a first round of revision.

Member of the **IFAC Technical Committee 2.5** on Robust Control, since 2015.

Scientific co-Chair of the of the 35th Int. Summer School of Automatic Control, Grenoble, September 2014, titled *Modern Tools for Nonlinear Control*, on novel nonlinear control tools developed in the last decades in the context of nonlinear observers design, hybrid control systems and nonlinear optimization.

Local Organizer of the International Summer School of Automatic Control, Grenoble, since 2018. The Summer School of Grenoble is a classical event for the French Automatic control community, with relevant international appeal. It reached its 43rd edition in 2022.

Editorial activity

Since 2017 I am a member of the CEB of the IEEE Control Systems Society and Associate editor for ECC since 2021. I also served as Technical Associate Editor (TAE) for the 21st IFAC World Congress 2020. Moreover, while my duty as reviewer of international journals and conferences was long lasting, I have also been involved in the expertise of ANR and ERC projects.

Associate Editor in the Conference Editorial Board of the IEEE CSS, since 2017.

Associate Editor in for European Control Conference, since 2021.

Associate Editor for IFAC WC2020: I served as Technical Associate Editor (TAE) for the 21st IFAC World Congress 2020.

Scientific expert for ANR Projects Proposals, 2016 and 2020.

Reviewer for several international journals (*IEEE Transactions on Automatic Control*, *Automatica*, *IEEE Transactions on Control Systems Technology*, *International Journal of Robust Nonlinear Control*, *Journal of Process Control*, *International Journal of Systems Science*, *Control Engineering Practice*, *Robotics and Autonomous Systems*, etc) and several international conferences (*CDC*, *ACC*, *ECC*, *IFAC-WC*, etc).

Projects direction

In 2021 the project DAMon (Data-based Anesthesia Monitoring) has been accepted to be funded by **LabEx PERSYVAL-Lab “équipe-actions” 2021-2024** (ANR-11-LABX-0025-01) funded by the French program Investissement d’avenir. The project, of which I am the coordinator, gathers teams from three laboratories in Grenoble area (GIPSA-lab, VERIMAG, TIMC-IMAG) and other laboratories (LAAS and CHU Ranguel Toulouse, University of Seville).

This research project aims at exploiting the potentialities of advanced control theory, formal verification and machine learning techniques to design and implement optimization and computation-oriented methods to assist the anesthesiologist during surgery. The main challenges to be addressed are the high uncertainty affecting the system dynamics, its variability in time and from patient to patient, the high risk sensitivity of the application, the necessity of accurate validation and certification of the proposed solution and the often partial information on the evolution of such a complex process. The access to real surgery operation data will have a central role for developing, applying and validating the proposed techniques, whose real-time embedded implementation is the ultimate objective.

From 2018 I have been participating to direct a collaborative industrial project with **Rio Tinto (Pechiney Group)**, on the modelling and control for the aluminum production process. The industrial research and development study has been realized in the framework of the PIANO (Pilotage Individuel des Anodes) project, that is a **FUI** funding program, and, in parallel, with a collaborative project between GIPSA-lab and Rio Tinto. Following the first project, active in the period 2018-2022, another project jointly funded by **“Plan de Relance CNRS”** and Rio Tinto has been signed, to continue working on the improvement of the electrochemical aluminum production process. The new industrial collaboration, starting in 2022 and lasting two years, 2022-2024, focuses more specifically on the anode effects prediction and prevention.

The main objective of both projects concerns the application of modelling and control techniques for improving the electrochemical process involved in the aluminum production. One main issue regards the identification of the partially unknown dynamics relating the measurements, i.e. the pot voltage and current, with the quantities to be controlled, namely the anode-cathode distance and the alumina concentration in the pot. The problem is particularly challenging since, besides the partial knowledge on the system parameters, no direct measure of the system state is available, except some specific, punctual measurement of the alumina concentration. The applied method consisting in an identification/estimation approach, led to a model and then to its use for control that has been applied to the industrial pots owned and operated at the Rio Tinto facility. Regarding the second project, it concerns the prediction and prevention of the anode effect, that is an highly undesirable and deleterious phenomenon that may occur when abnormally low values of alumina concentration are locally present in the pot.

I have also been the GIPSA-lab responsible of the industrial collaboration contract with **CALOR ent. (SEB group)**, for the period 2018-2020.

The project, confidential in its details, concerned the application of methods from systems identification and state observation together with machine learning techniques for improving the performances for small electrical appliances produced by SEB.

I have been the GIPSA-lab coordinator of the **PERSYVAL exploratory projet** (Set

Theory and Algorithms for Dynamical Systems) funded by LabEx PERSYVAL-Lab (ANR-11-LABX-0025-01). The project started in 01/03/2014 and lasted 18 months. It was funded with 9500 euro and was in collaboration with LJK (**A. Girard** currently at L2S, Paris) and VERIMAG (**T. Dang**), Grenoble.

The main objective of the proposed research project was twofold. On one hand, we wanted to extend and apply the results proper of set theory for analysis and control to wider classes of dynamical systems. On the other hand, we aimed at computation-oriented results that might be exploitable in order to implement algorithm for computing the sets (reachable, invariant, contractive, etc) which provide insight on the dynamical behavior of the systems.

Responsibilities

I have been, from 11/2014 to 12/2019, the **vice-head of the group SYSCO** of GIPSA-lab, to which I belong and that was composed by 14 permanent researcher/teachers.

I am currently, since 01/2020, the **head of the group MODUS** of GIPSA-lab, to which I belong and that is composed by 9 permanent researcher/teachers.

2.4 List of publications

International journal papers :

1. D. Denardi Huff, M. Fiacchini, J. M. Gomes da Silva Jr. (2022) **Necessary and Sufficient Convex Condition for the Stabilization of Linear Sampled-data Systems under Poisson Sampling Process**, *IEEE Control Systems Letters (L-CSS)*, **6**, 3403-3408.
2. D. Denardi Huff, M. Fiacchini, J. M. Gomes da Silva Jr. (2022) **Polyhedral Estimates of the Region of Attraction of the Origin of Linear Systems under Aperiodic Sampling and Input Saturation**, *Automatica*, **144**.
3. K. Moussa, M. Fiacchini, M. Alamir, (2022) **Probabilistically certified region of attraction of a tumor growth model with combined chemo- and immunotherapy**, *Int. J. Robust Nonlinear Control*, **32**(11), 6539-6555.
4. L. J. da Silva Moreira, M. Fiacchini, G. Besançon, F. Ferrante, H. Roustan, (2022) **Modeling and Observer Design for Aluminum Manufacturing**, *European Journal of Control*, **64**.
5. K. Moussa, M. Fiacchini, M. Alamir, (2021) **Robust domain of attraction estimation for a tumor growth model**. *Applied Mathematics and Computation*, **410**.
6. M. Fiacchini, T. Alamo, (2021) **Probabilistic reachable and invariant sets for linear systems with correlated disturbance**. *Automatica*, **357**(5), 2978-2996.
7. M. Fiacchini, (2021) **Yet another computation-oriented necessary and sufficient condition for stabilizability of switched linear systems**. *IEEE Transactions on Automatic Control*, **357**(5), 2978-2996.
8. D. Denardi Huff, M. Fiacchini, J. M. Gomes da Silva Jr. (2021) **Polyhedral Regions of Stability for Aperiodic Sampled-data Linear Control Systems with Saturating Inputs**. *IEEE Control Systems Letters (L-CSS)*, **357**(5), 2978-2996.
9. D. Denardi Huff, M. Fiacchini, J. M. Gomes da Silva Jr. (2021) **Stability and Stabilization of Sampled-data Systems subject to Control Input Saturation: a set invariant approach**. *IEEE Transactions on Automatic Control*, **357**(5), 2978-2996.
10. M. Fiacchini, M. Alamir. (2021) **The Ockham's razor applied to COVID-19 model fitting French data**. *Annual Reviews in Control*, **357**(5), 2978-2996.
11. I. Hosseini, M. Fiacchini, P. Karimaghaee, A. Khayatian. (2020) **Optimal reset unknown input observer design for fault and state estimation in a class of nonlinear uncertain systems**. *Journal of the Franklin Institute*, **357**(5), 2978-2996.
12. M. Fiacchini, G. Millérioux. (2019) **Dead-beat stabilizability of discrete-time switched linear systems: algorithms and applications**. *IEEE Transactions on Automatic Control*, **64**(9). 3839-3845.
13. I. Hosseini, A. Khayatian, P. Karimaghaee, M. Fiacchini, M. A. Davo. (2019) **LMI-based reset unknown input observer for state estimation of linear uncertain systems**. *IET Control Theory & Applications*, **13**. 1872-1881.
14. R. Riah, M. Fiacchini, M. Alamir. (2019) **Iterative method for estimating the robust domains of attraction of non-linear systems: Application to cancer chemotherapy model with parametric uncertainties**. *European Journal of Control*, **47**. 64-73.
15. M. Alamir, M. Fiacchini, I. Queinnec, S. Tarbouriech, M. Mazerolles. (2018) **Feedback law with probabilistic certification for Propofol-based control of BIS during anesthesia**. *Int. J. Robust Nonlinear Control*, **28**. 6254-6266.

16. M. Fiacchini, M. Jungers, A. Girard. (2018) **Stabilization and control Lyapunov functions for language constrained discrete-time switched linear systems**. Regular paper in *Automatica*, **93**. 64-74.
17. R. Gonzalez, M. Fiacchini, K. Iagnemma. (2018) **Slippage prediction for off-road mobile robots via machine learning regression and proprioceptive sensing**. *Robotics and Autonomous Systems*, **105**. 85-93.
18. S. Ben Chabane, M. Alamir, M. Fiacchini, R. Riah, T. Kovaltchouk, S. Bacha. (2018) **Electricity grid connection of a tidal farm: an active power control framework constrained to grid code requirements**. *IEEE Transactions on Sustainable Energy*, **9**. 1948-1956.
19. M. A. Davo, C. Prieur, M. Fiacchini, D. Nešić. (2018) **Enlarging the basin of attraction by a uniting output feedback controller**. *Automatica*, **90**. 73-80.
20. M. A. Davo, C. Prieur, M. Fiacchini. (2017) **Stability analysis of output feedback control systems with memory-based event-triggering mechanism**. *IEEE Transactions on Automatic Control*, **62**(12). 6625-6632.
21. M. Fiacchini, S. Tarbouriech. (2017) **Control co-design for discrete-time switched linear systems**. *Automatica*, **82**. 181-186.
22. M. Fiacchini, A. Girard, M. Jungers. (2016) **On the stabilizability of discrete-time switched linear systems: novel conditions and comparisons**. Full paper in *IEEE Transactions on Automatic Control*, **61**(5). 1181-1193.
23. M. Fiacchini and I.-C. Morărescu. (2016) **Constructive necessary and sufficient condition for the stability of quasi-periodic linear impulsive systems**. *IEEE Transactions on Automatic Control*, **61**(9). 2512-2517.
24. A. Tanwani, C. Prieur, M. Fiacchini. (2016) **Observer-based feedback stabilization of linear systems with event-triggered sampling and dynamic quantization**. *Systems & Control Letters*, **94**. 46-56.
25. M. Fiacchini, C. Prieur, S. Tarbouriech. (2015) **On the computation of set-induced control Lyapunov functions for continuous-time systems**. *SIAM Journal on Control and Optimization*, **53**(3). 1305 - 1327.
26. T. Manrique, M. Fiacchini, T. Chambrion, G. Millerioux (2015) **MPC-based tracking for real-time systems subject to time-varying polytopic constraints**. *Optimal Control Applications and Methods*, **37**. 708-729.
27. A. H. González, A. Ferramosca, G. A. Bustos, J. L. Marchetti, M. Fiacchini, D. Odloak (2014) **Model predictive control suitable for closed-loop re-identification**. *Systems & Control Letters*, **69**. 23 - 33.
28. I.-C. Morărescu, M. Fiacchini. (2014) **LMI conditions for topology preservation: application to multi-agents tasks**. *Journal of Control Engineering and Technology*, **4**(3). 183 - 191.
29. M. Fiacchini, I.-C. Morărescu. (2014) **Convex conditions on decentralized control for graph topology preservation**. *IEEE Transactions on Automatic Control*, **59**(6). 1640 - 1645.
30. M. Fiacchini, M. Jungers. (2014) **Necessary and sufficient condition for stabilizability of discrete-time linear switched systems: A set-theory approach**. *Automatica*, **50**(1). 75 - 83.
31. M. Fiacchini, G. Millerioux. (2013) **Dead-beat functional observers for discrete-time LPV systems with unknown inputs**. *IEEE Transactions on Automatic Control*, **58**(12). 3230 - 3235.

32. M. Fiacchini, T. Alamo, E. F. Camacho. (2012) **Invariant sets computation for convex difference inclusions systems.** *Systems & Control Letters*, **61**. 819 - 826.
33. M. Fiacchini, S. Tarbouriech, C. Prieur. (2012) **Quadratic stability for hybrid systems with nested saturations.** *IEEE Transactions on Automatic Control*, **57**. 1832 -1838.
34. R. Gonzalez, M. Fiacchini, T. Alamo, J. L. Guzman, F. Rodriguez. (2011) **Online robust tube-based MPC for time-varying systems: A practical approach.** *International Journal of Control*, **84**. 1157 - 1170.
35. R. Gonzalez, M. Fiacchini, J. L. Guzman, T. Alamo, F. Rodriguez. (2011) **Robust tube-based predictive control for mobile robots in off-road conditions.** *Robotics and Autonomous Systems*, **59**. 711 - 726.
36. S. Tarbouriech, I. Queinnec, T. Alamo, M. Fiacchini, E. F. Camacho. (2011) **Ultimate bounded stability and stabilization of linear systems interconnected with generalized saturated functions.** *Automatica*, **47**. 1473 - 1481.
37. M. Fiacchini, T. Alamo, E. F. Camacho. (2010) **On the computation of convex robust control invariant sets for nonlinear systems.** *Automatica*, **46**. 1334 - 1338.
38. R. Gonzalez, M. Fiacchini, T. Alamo, J. L. Guzman, F. Rodriguez. (2010) **Adaptive control for a mobile robot under slip conditions using an LMI-based approach.** *European Journal of Control*, **16**. 144 - 158.
39. T. Alamo, A. Cepeda, M. Fiacchini, E.F. Camacho. (2009) **Convex invariant sets for discrete-time Lur'e systems.** *Automatica*, **45**. 1066 - 1071.
40. M. Fiacchini, T. Alamo, I. Alvarado, E. F. Camacho. (2008) **Safety verification and adaptive model predictive control of the hybrid dynamics of a fuel cell system.** *International Journal of Adaptive Control and Signal Processing*, **22**. 142 - 160.
41. L. A. Viguria, A. Prieto, M. Fiacchini, R. Cano, F. Rodriguez, J. Aracil, C. Canudas de Wit. (2006) **Desarrollo y experimentación de un vehículo basado en péndulo invertido (Ppcar).** *Riai: Revista Iberoamericana de Automática e Informática Industrial*, **3**. 54 - 63.

Book chapters :

1. M. Fiacchini, M. Jungers, A. Girard, S. Tarbouriech (2018) **Stabilizability and control co-design for discrete-time switched linear systems.** *Control subject to Computational and Communication Constraints: Current Challenges*, Springer.
2. M. Fiacchini and I.-C. Morărescu. (2016) **Topology preservation for multi-agent networks: design and implementation.** *Delays and Networked Control Systems*, Springer.
3. M. Fiacchini, S. Tarbouriech, C. Prieur. (2013). **Exponential stability for hybrid systems with saturations.** *Hybrid systems with constraints*. ISTE Ltd and John Wiley & Sons Inc. 179 - 212.
4. T. Alamo, M. Fiacchini, A. Cepeda, D. Limon, E. F. Camacho, J. M. Bravo. (2007). **On the computation of robust control invariant sets for piecewise affine systems.** *Assessment and Future Directions of Nonlinear Model Predictive Control (Lncis)*. New York. Springer-Verlag. 131 - 140.

International conferences :

1. D. Denardi Huff, M. Fiacchini, J. M. Gomes da Silva Jr. (2022) **Necessary and Sufficient Convex Condition for the Stabilization of Linear Sampled-data Systems under**

- Poisson Sampling Process**, *61st Conference on Decision and Control CDC22*, Cancun, Mexico.
2. H. Boukerrou, G. Millerioux, G. M. Minier, M. Fiacchini. (2022) **Construction of dead-beat switched automata: application to cryptography**, *10th International Conference on Systems and Control (ICSC)*, Marseille, France.
 3. M. Fiacchini, T. Alamo. (2022) **Stochastic model predictive control for linear systems affected by correlated disturbances**, *10th IFAC Symposium on Robust Control Design ROCOND 2022*, Kyoto, Japan.
 4. L. M. Chaouach, M. Fiacchini, T. Alamo. (2022) **Indirect feedback stochastic model predictive control for linear systems affected by correlated disturbances**, *10th IFAC Symposium on Robust Control Design ROCOND 2022*, Kyoto, Japan.
 5. D. Denardi Huff, M. Fiacchini, J. Gomes da Silva Jr. (2021) **Stabilization of Aperiodic Sampled-data Linear Systems with Input Constraints: a Low Complexity Polyhedral Approach**, *60th Conference on Decision and Control CDC21*, Austin, TX, USA.
 6. L. J. da Silva Moreira, G., Besançon, F., Ferrante, M. Fiacchini, H. Roustan (2021) **Observer Based Predictive Controller for Hall-Heroult Process**, *2021 European Control Conference (ECC)*.
 7. L. J. da Silva Moreira, M. Fiacchini, G., Besançon, F., Ferrante, H. Roustan (2020) **State Affine Modeling and Observer Design for Hall-Hérault Process**. *IFAC World Congress 2020*.
 8. L.J. da Silva Moreira, G. Besançon, F. Ferrante, M. Fiacchini, H. Roustan (2020) **Model based approach for online monitoring of aluminum production process**. *TMS Annual Meeting*, San Diego, CA, USA.
 9. K. Moussa, M. Fiacchini, M. Alamir. (2019) **Robust Optimal Scheduling of Combined Chemo- and Immunotherapy: Considerations on Chemotherapy Detrimental Effects**. *the 2020 American Control Conference (ACC20)*, Denver, USA.
 10. K. Moussa, M. Fiacchini, M. Alamir. (2019) **Robust optimal control-based design of combined chemo and immunotherapy delivery profiles**. *The 8th IFAC Conference on Foundations of Systems Biology in Engineering (FOSBE 2019)*, Valencia, Spain.
 11. M. Fiacchini, J.M. Gomes da Silva Jr. (2018) **Stability of sampled-data control systems under aperiodic sampling and input saturation**. *The 57th IEEE Conference on Decision and Control (CDC 2018)*, Miami Beach, USA.
 12. M. Jungers, A. Girard, M. Fiacchini. (2018) **Language constrained stabilization of discrete-time switched linear systems: an LMI approach**. *IFAC Conference on Analysis and Design of Hybrid Systems (ADHS 2018)*. Oxford, UK.
 13. M. Fiacchini, G. Millérioux. (2017) **Dead-beat stabilizability of autonomous switched linear discrete-time systems**. *The 20th IFAC World Congress (IFAC 2017)*, Toulouse, France.
 14. M. Fiacchini, I.-C. Morărescu. (2016) **Stability analysis for systems with asynchronous sensors and actuators** *The 55th IEEE Conference on Decision and Control (CDC 2016)*. Las Vegas. USA.
 15. M. Alamir, M. Fiacchini. (2016) **Observer-based efficiency enhancement in cell-cycle specific therapies**. *The 55th IEEE Conference on Decision and Control (CDC 2016)*. Las Vegas. USA.
 16. M. Jungers, A. Girard, M. Fiacchini. (2016) **Language constrained stabilization of discrete-time switched linear systems: a Lyapunov-Metzler inequalities approach**. *The 55th IEEE Conference on Decision and Control (CDC 2016)*. Las Vegas. USA.

17. M. A. Davo, M. Fiacchini, C. Prieur. (2016) **Output memory-based event-triggered control.** *The 55th IEEE Conference on Decision and Control (CDC 2016)*. Las Vegas. USA.
18. M. Fiacchini, I. Queinnec, S. Tarbouriech, M. Mazerolles. (2016) **Invariant based control of induction and maintenance phases for anesthesia.** *The 6th IFAC Conference on Foundations of Systems Biology in Engineering (FOSBE 2016)*. Magdeburg. Germany.
19. M. Fiacchini, M. Jungers, A. Girard. (2016) **Exponential stabilization of language constrained discrete-time switched linear systems: a geometrical approach.** *The 15th European Control Conference 2016 (ECC16)*. Aalborg. Denmark.
20. R. Riah, M. Fiacchini, M. Alamir. (2016) **Domain of attraction estimation of cancer chemotherapy model affected by state proportional uncertainty.** *The 15th European Control Conference 2016 (ECC16)*, Aalborg, Denmark.
21. T. Kovaltchouk, V. Debusschere, S. Bacha, M. Fiacchini, M. Alamir. (2016) **Assessment of the Impact of Frequency Containment Control and Synthetic Inertia on Intermittent Energies Generators Integration.** *The EVER Conference 2016*. Monaco.
22. M. Alamir, M. Fiacchini, S. Ben Chabane, S. Bacha, T. Kovaltchouk. (2016) **Active Power Control under Grid Code Constraints for a Tidal Farm.** *The EVER Conference 2016*. Monaco.
23. R. Riah, M. Fiacchini, M. Alamir. (2015) **Invariance-based analysis of cancer chemotherapy.** *The 2015 IEEE Multi-Conference on Systems and Control (MSC15), 2015*. Sydney. Australia.
24. R. Riah, M. Fiacchini. (2015) **New condition for invariance of ellipsoidal sets for discrete-time saturated systems.** *The 2015 IEEE Multi-Conference on Systems and Control (MSC15), 2015*. Sydney. Australia.
25. M. Alamir, M. Fiacchini, A. Stéphanou (2015) **Reduced model for 2D tumor growth and tumor induced angiogenesis.** *The 14th European Control Conference 2015 (ECC15)*. Linz. Austria.
26. M. Fiacchini, A. Girard, M. Jungers. (2014) **On stabilizability conditions for discrete-time switched linear systems.** *The 53th Conference on Decision and Control (CDC 2014)*. Los Angeles, California. USA.
27. M. Fiacchini, I.-C. Morărescu (2014) **Set theory conditions for stability of linear impulsive systems.** *The the 53th Conference on Decision and Control (CDC 2014)*. Los Angeles, California. USA.
28. T. Manrique, M. Fiacchini, T. Chambrion, G. Millerioux (2014) **MPC tracking under time-varying polytopic constraints for real-time applications** *The 13th European Control Conference (ECC14)*. Strasbourg. France.
29. M. Fiacchini, C. Prieur, S. Tarbouriech. (2013) **Necessary and sufficient conditions for invariance of convex sets for discrete-time saturated systems.** *The 52nd IEEE Conference on Decision and Control (CDC 2013)*. Florence. Italy.
30. M. Fiacchini, M. Jungers. (2013) **Necessary and sufficient condition for stabilizability of discrete-time linear switched systems: a set-theory approach.** *The 2013 IFAC joint conference, 5th Symposium on System Structure and Control (IFAC-SSSC 2013)*. Grenoble. France.
31. T. Manrique, M. Fiacchini, T. Chambrion, G. Millerioux. (2013) **MPC for a low consumption electric vehicle with time-varying constraints.** *The 2013 IFAC joint conference, 5th Symposium on System Structure and Control (IFAC-SSSC 2013)*. Grenoble. France.

32. M. Fiacchini, G. Millerioux (2012) **Fast input-free observers for LPV discrete-time systems.** *The 51th IEEE Conference on Decision and Control (CDC 2012)*. Hawaii. USA.
33. M. Fiacchini, I.-C. Morărescu (2012) **Set-theory based condition for network topology preservation for decentralized control.** *The 51th IEEE Conference on Decision and Control (CDC 2012)*. Hawaii. USA.
34. T. Manrique, H. Malaise, M. Fiacchini, T. Chambrion, G. Millerioux (2012) **Model Predictive Real-Time controller for a low-consumption electric vehicle.** *The 2nd International Symposium on Environment-Friendly Energies and Applications (EFEA 2012)*. Newcastle. United Kingdom.
35. M. Fiacchini, S. Tarbouriech, C. Prieur. (2011) **Invariance of symmetric convex sets for discrete-time saturated systems.** *The 50th IEEE Conference on Decision and Control and European Control Conference (CDC-ECC 2011)*. Orlando. USA.
36. M. Fiacchini, S. Tarbouriech, C. Prieur. (2011) **Polytopic control invariant sets for continuous-time systems: a viability theory approach.** *The 2011 American Control Conference*. San Francisco. USA.
37. M. Fiacchini, S. Tarbouriech, C. Prieur. (2011) **Ellipsoidal invariant sets for saturated hybrid systems.** *The 2011 American Control Conference*. San Francisco. USA.
38. R. Gonzalez, M. Fiacchini, J. L. Guzman, T. Alamo. (2009) **Robust tube-based MPC for constrained mobile robots under slip condition.** *The 48th IEEE Conference on Decision and Control (CDC 2009)*. Shanghai. China.
39. R. Gonzalez, M. Fiacchini, T. Alamo, J. L. Guzman, F. Rodriguez. (2009) **Adaptive control for a mobile robot under slip conditions using an LMI-based approach.** *The European Control Conference 2009*. Budapest. Hungary.
40. S. V. Rakovic, M. Fiacchini. (2008) **Approximate reachability analysis for linear discrete time systems using homothety and invariance.** *The 17th IFAC World Congress 2008*. Seoul. Korea.
41. S. V. Rakovic, M. Fiacchini. (2008) **Invariant approximations of the maximal invariant set or "Encircling the square".** *The 17th IFAC World Congress 2008*. Seoul. Korea.
42. J. M. Bravo, T. Alamo, M. Fiacchini, E. F. Camacho. (2007) **A Convex approximation of the feasible solution set for nonlinear bounded-error identification problems.** *The 46th IEEE Conference on Decision and Control (CDC 2007)*. New Orleans. USA.
43. M. Fiacchini, T. Alamo, E. F. Camacho. (2007) **On the computation of local invariant sets for nonlinear systems.** *The 46th IEEE Conference on Decision and Control (CDC 2007)*. New Orleans. USA.
44. I. Alvarado, D. Limon, T. Alamo, M. Fiacchini, E. F. Camacho. (2007) **Robust tube based MPC for tracking of piece-wise constant references.** *The 46th IEEE Conference on Decision and Control (CDC 2007)*. New Orleans. USA.
45. M. Fiacchini, T. Alamo, E. F. Camacho. (2007) **Piecewise affine model of a fuel cell for safety verification.** *The American Control Conference 2007*. New York, New York. USA.
46. M. Fiacchini, T. Alamo, C. Albea, E. F. Camacho. (2006) **Adaptive model predictive control of the hybrid dynamics of a fuel cell system.** *The 16th IEEE International Conference on Control Applications*. Singapore.
47. M. Fiacchini, A. Viguria, R. Cano, A. Prieto, F. Rodriguez, J. Aracil, C. Canudas de Wit. (2006) **Design and experimentation of a personal pendulum vehicle.** *The 7th Portuguese Conference on Automatic Control*. Lisbon. Portugal.

48. M. Fiacchini, I. Alvarado, D. Limon, T. Alamo, E. F. Camacho. (2006) **Predictive control of a linear motor for tracking of constant reference.** *The 45th IEEE Conference on Decision and Control (CDC 2006)*. San Diego. USA.
49. M. Fiacchini, T. Alamo, E. F. Camacho. (2006) **Suboptimal model predictive control of hybrid systems through spherical discretization mesh.** *The IFAC International Workshop on Nonlinear Model Predictive Control for Fast Systems. Nmpc'06*. Grenoble. France.
50. T. Alamo, D. Limon, A. Cepeda, M. Fiacchini, E. F. Camacho. (2006) **Synthesis of robust saturated controller: an SNS-approach.** *The 5th IFAC Symposium on Robust Control Design*. Toulouse. France.
51. T. Alamo, A. Cepeda, D. Limon, J. M. Bravo, M. Fiacchini, E. F. Camacho. (2005) **On the computation of robust control invariant sets for piecewise affine systems.** *The IFAC International Workshop on Assessment and Future Directions of Nonlinear Predictive Control. Nmpc'05*. Freudenstadt-Lauterbad. Germany.

Spanish national conferences :

1. I. Alvarado, M. Fiacchini, D. Limon, T. Alamo, E. F. Camacho. (2006) **Control Predictivo para el Seguimiento de Referencias Constantes Aplicado a un Motor Lineal.** *Actas de las XXVII Jornadas de Automática*. Almería. Spain.
2. M. Fiacchini, E. F. Camacho. (2005) **Control Predictivo de Sistemas Híbridos a Través de Malla de Discretización Circular.** *Actas de las XXVI Jornadas de Automática*. Alicante. Spain.
3. A. Viguria, R. Cano, M. Fiacchini, A. Prieto, B. J. Vela, F. Rodríguez, J. Aracil, C. Canudas de Wit. (2005) **Ppcar (Personal Pendulum Car): Vehículo Basado en Péndulo Invertido.** *Actas de las XXVII Jornadas de Automática*. Alicante. Spain.

Scientific production

Contents

3.1	Research lines	24
3.1.1	Stabilizability of switched systems	24
3.1.2	Systems with aperiodic sampling and saturation	26
3.1.3	Model predictive control and invariance	27
3.1.4	Modeling and control for cancer dynamics	29
3.1.5	Anesthesia monitoring	29
3.1.6	Modeling and control for aluminium production	30
3.1.7	Data and learning for control	31
3.1.8	Functional observers for discrete-time LPV systems	32
3.1.9	Decentralized systems	33
3.1.10	Hybrid systems with saturation	33
3.1.11	Unknown input observer for uncertain systems	34
3.2	Conclusions	34

The topics to which my research activity has been directed are tightly related to set-theoretic methods for control and systems analysis, from both the theoretical and the application points of view. I have been interested to models affected by elements representing the complexities of real world systems, as saturation and other static nonlinear elements, discontinuous behaviors, aperiodic sampling, stochastic noises or bounded disturbances, and parameter uncertainties. In general, set-theoretic methods refer to techniques concerning properties shared by all the elements of sets of the state space. A particularly important example in the field of dynamical systems and control design involving set-theoretic methods is represented by invariance.

An invariant set, for a given dynamical system, is a region of the state space such that the trajectory generated by the system remains confined in the set if the initial condition lies within it, see [Blanchini and Miani, 2008]. The concept of invariance has become fundamental for the analysis and design of control systems. Although many research efforts have been directed to related themes throughout the whole second half of the last century, see [Bertsekas, 1972, Gutman and Cwikel, 1986a, Gutman and Cwikel, 1987, Gilbert and Tan, 1991, Blanchini, 1994], [Blanchini, 1995, Kolmanovsky and Gilbert, 1998a, Blanchini, 1999], the field became particularly active in the last years, [Korda et al., 2014b, Athanasopoulos et al., 2014, Henrion and Korda, 2014, Tahir and Jaimoukha, 2015, Blanco et al., 2010, Jones and Peet, 2021a, Jones and Peet, 2021b]. The importance of invariant sets in control is due to the implicit stability and safety properties of these regions of the state space. Set-theory and invariance have strong theoretical relations with the following classical topics in the field of control and dynamical systems analysis:

- hard constraints satisfaction;
- stability and stabilizability analysis;
- computation and estimation of domains of attraction;
- Lyapunov functions and convergence;

- Model Predictive Control.

Moreover, a tight link exists with optimization, which makes set-theory methods particularly suitable to be applied to practical problems. These methods and techniques, well established in the context of linear systems, are the basis for dealing with problems of control for more complex families of systems, such that nonlinear, hybrid, switched, distributed etc. This has been the idea underlining my research. Hereafter, some details are given on the research activity I have been working on.

3.1 Research lines

Hereafter, my main scientific research lines are presented to offer an overview on my recent activity. Some of them will be illustrated in more detail in the subsequent chapters.

3.1.1 Stabilizability of switched systems

Switched systems are characterized by dynamics that may change along the time among a finite number of possible dynamical behaviors, see [Liberzon, 2003]. Each behavior is determined by a mode and the active one is selected by means of a function of time, referred to as switching law. The interest that such kind of systems rose in the last decades lies in their capability of modeling complex real systems, as embedded or networked ones, and also for the theoretical issues involved. The problem of stability or stabilizability, depending on the assumption on the switching law nature, of switched linear system attracted many research efforts, see the overview [Lin and Antsaklis, 2009] and the monograph [Sun and Ge, 2011]. Conditions for stability, that is when the switching law is considered as an exogenous signal, have been proposed: for instance, the joint spectral radius approach [Jungers, 2009a]; those based on polyhedral Lyapunov functions [Molchanov and Pyatnitskiy, 1989, Blanchini, 1995] or on path-dependent switched Lyapunov ones [Lee and Dullerud, 2007].

This research topic has been widely treated in my past research activity. In particular, I have been working, together with my collaborators, to the problems of characterizing the conditions for stabilizability [Fiacchini et al., 2012b, Fiacchini and Jungers, 2013, Fiacchini and Jungers, 2014], [Fiacchini et al., 2016a, Fiacchini et al., 2016b, Fiacchini et al., 2018, Fiacchini, 2021]; on dead-beat stabilizability of switched linear discrete-time systems [Fiacchini and Millérioux, 2017]; on the simultaneous co-design of the control feedback and the switching law for switched systems [Fiacchini and Tarbouriech, 2017].

- The first research line, result of a collaboration with **M. Jungers, of CRAN, Nancy and A. Girard, of LJK, Grenoble and then L2S, Paris**, has been the problem of stabilizability of switched linear systems, namely the condition under which a switching law can be designed for the system to be asymptotically stable. Concerning the problem of stabilizability of switched system, it is known that convex Lyapunov functions lead to conservative results, and nonconvex ones must be considered, see [Blanchini and Savorgnan, 2008]. Nonconvex Lyapunov functions induced by the union of ellipsoids are used in [Daafouz et al., 2002, Geromel and Colaneri, 2006b, Zhang et al., 2009, Heemels et al., 2016a], while more general homogeneous functions have been considered in [Fiacchini and Jungers, 2014]. On this topic, we proposed novel stabilizability conditions together with the characterization of the relation between different conditions from the literature, in particular those based on Lyapunov-Metzler ones, in [Fiacchini et al., 2016a].
- Another contribution on this topic, developed with **A. Girard, of LJK, Grenoble and then L2S, Paris** and **M. Jungers, of CRAN, Nancy**, is given in [Fiacchini et al., 2016b, Jungers et al., 2016, Jungers et al., 2018, Fiacchini et al., 2018] and concerns the problem

of stabilizability of switched linear systems subject to constraints on the switching law. In many practical cases, indeed, the mode sequence might be required to satisfy some conditions. Consider for instance the problems of safety specifications, the tasks scheduling, the interaction between control and software implementation and the constraints on dwell-time switching. Several kinds of these constraints may be modeled by a nondeterministic finite automaton by imposing that the switching law belongs to the language generated by such an automaton. The problem of determining stabilizing feedback control policies satisfying language constraints has not been widely treated in literature. For this purpose, we considered nonconvex star-shaped sets and their gauge functions as Lyapunov candidates, as in [Fiacchini and Jungers, 2014], to provide algorithms leading to constructive conditions for stabilizability.

- A third research line, developed in collaboration with **G. Millerioux, of CRAN, Nancy**, concerned the dead-beat stabilizability of discrete-time switched linear systems, namely the problem of checking if a sequence of switches exists that drives the whole state space to the origin. This problem is related to the property of mortality of a set of matrices. Indeed, a set of matrices is mortal if the zero matrix can be expressed as the product of finite length of matrices. In general, the problem of checking the mortality of a set of matrices is unsolvable. On this topic we provided in [Fiacchini and Millérioux, 2017, Fiacchini and Millérioux, 2018] a constructive method to check if a finite sequence of switches exists that gives the null matrix and to compute it, if it exists. The benefit of the proposed method is illustrated by comparison with the brute-force approach based on the exhaustive search over all the possible sequences of bounded length. Moreover the method has been recently applied in the field of cryptography [Boukerrou et al., 2022].
- Another research line related to switched linear systems concerns the practical problem of applicability of the necessary and sufficient conditions for stabilizability to get constructive methods for switching control design. Although necessary and sufficient conditions are available, in fact, their complexity led to inspect alternative conditions, just sufficient but more computationally affordable. No relevant results are available, though, on the practical problem of computability for the necessary and sufficient conditions for stabilizability. The notable exception [Jungers and Mason, 2017] proposes algorithms to test necessary and sufficient conditions for stabilizability and to compute tight bounds on the convergence rate. A contribution to this problem, presented in [Fiacchini, 2021], consisted in providing an algorithmic method to test whether a necessary and sufficient condition for stabilizability is satisfied for a switched linear system. The method is based on a novel necessary and sufficient stabilizability condition, consisting in the existence of a conic cover of the space on whose cones a convex condition holds. It has been proved to be applicable also for computing tight bounds on the maximal convergence rate of the switching laws. The computational method allowed to test the necessary and sufficient stabilizability condition for relatively high dimensional systems, in particular for a four dimensional switched system, for which the only alternative numerical approach to the problem, namely the cited [Jungers and Mason, 2017], is not applicable due to the prohibitive complexity required. The code and numerical results of the application of the method presented in the paper [Fiacchini, 2021] have been made available online.
- Finally we addressed, in collaboration with **Sophie Tarbouriech from LAAS**, the problem of the control feedback and switching law co-design. The problem of co-designing both the switching law and the control feedback input, in fact, is even more involved than the problem of stabilizability of autonomous switched systems. This kind of problem has been addressed in several works, based on approximating the LQR control, see [Zhang et al., 2009, Zhang et al., 2012, Antunes and Heemels, 2016]. Our approach, presented in [Fiacchini and Tarbouriech, 2017], is based on the convex conditions for stabilization of autonomous systems presented in [Fiacchini et al., 2016a], that are necessary and

sufficient for periodic stabilizable systems. The problem is treated by providing an analogous LMI constructive condition for stabilizability that is proved to be necessary and sufficient for systems that are periodic stabilizable through co-design.

3.1.2 Systems with aperiodic sampling and saturation

This research line focuses on computation-oriented conditions for the stability and stabilizability of systems presenting aperiodic sampling and being affected by input saturation. Motivated by the growing use of embedded controllers in different applications, where a communication protocol is responsible for the transmission of data between computer algorithms, actuators and sensors, and by the diffused interactions between physical systems and digital devices, the analysis and control design for cyber-physical systems have been addressed in many recent works. In cyber-physical systems, in fact, many phenomena can affect the control loop, as imperfections in the communications, time-varying delay, sampling jitters, packets dropout, hard and software requirements and actuators limitations.

In this context, aperiodic sampling can be seen as a modeling abstraction employed to represent, in a theoretical framework, the effect of imperfections in the communication channel such as sampling jitters, fluctuations and, in some cases, packet dropouts. The survey [Hetel et al., 2017] presents several existing methods to analyze the stability of aperiodic sampled-data systems when the dynamics is assumed to be linear.

Moreover, due to physical limitations of actuators, the input saturation is virtually unavoidable in real control problems. It is a source of performance degradation and, in many cases, only local stability of the closed-loop system can be ensured, even for linear plants. In the periodic sampled-data case, as the saturation nonlinearity affects only the input, the stability analysis can be carried out by using a discrete-time model (see [Tarbouriech et al., 2011] and references therein) obtained by exact discretization. Nevertheless, for the aperiodic sampled-data case, the problem is more involved and requires a careful analysis of the hybrid behavior of the system. On this subject, works exist, [Seuret and Gomes da Silva Jr., 2012] and [Fiacchini and Gomes da Silva Jr., 2018] for instance, which provide LMI-based techniques to compute ellipsoidal estimates of the region of attraction of the origin (RAO) of the closed-loop system, which can be seen as safe regions of operation.

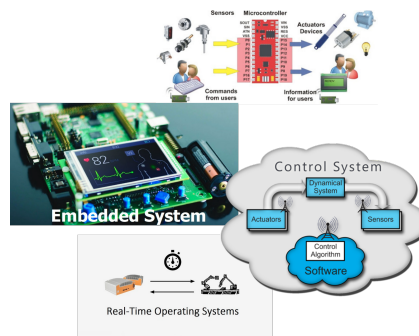

Figure 3.1: Cyber-physical systems

This research line focusses on the determination of ellipsoidal and polyhedral estimates of the RAO. The results proposed leverage the use of a discrete-time model that describes the behavior of the system state between consecutive sampling instants. It can be proved, in fact, that if the discrete-time trajectories converge to the origin then the continuous-time ones also do. Considering the discrete-time model leads to a difference inclusion if the sampling instant is considered unknown but bounded within a certain time interval. Resorting to methods for dealing with the saturation of discrete-time linear systems, computation-oriented results are obtained for determining estimations of the RAO and set-induced Lyapunov functions. Therefore, asymptotic convergence of systems with aperiodic sampling and input saturation can be proved. In particular, convex conditions, in form of LMI are provided in [Fiacchini and Gomes da Silva Jr., 2018, Denardi Huff et al., 2022b], while the more computationally involved, but less conservative, approaches based on polyhedral sets iterative computation are presented in [Denardi Huff et al., 2022a, Denardi Huff et al., 2022].

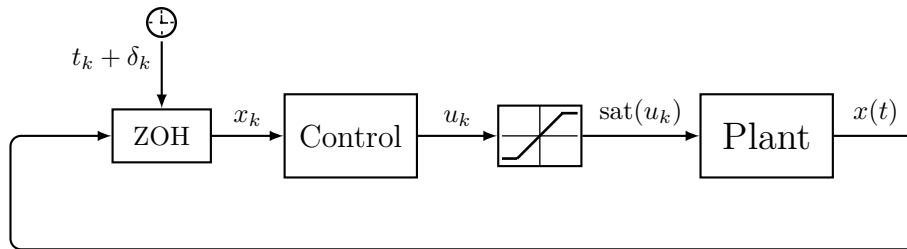

Figure 3.2: Closed-loop system with saturation input and aperiodic sampling

This study has been carried out in collaboration with **J.M. Gomes da Silva Jr., from UFRGS, Brazil**, with whom I was directing the thesis of **Daniel Denardi Huff**, co-funded by the IDEX UGA and the Brazilian COPEs in the framework of an international cooperation project.

3.1.3 Model predictive control and invariance

Model Predictive Control is a control technique whose popularity mostly relies in its capability of dealing with constraints and of ensuring performance optimization and in its suitability for practical applications, by guaranteeing, at the same time, desirable stability properties [Mayne et al., 2000, Camacho and Bordóns, 2004, Kouvaritakis and Cannon, 2016, Rawlings et al., 2017]. The inherent MPC aim of real implementation of control led to focus on the effects of model uncertainties, disturbances and noises on the control performances and stability, yielding to robust and stochastic formulations of MPC, besides the deterministic one.

Concerning the problem of convergence of MPC strategies, those based on invariant sets as terminal constraint are possibly the most popular. Indeed, the strategies based on invariant sets allow to guarantee convergence towards the origin by implicitly extending the prediction horizon to the infinity without any substantial increasing of the on-line computational cost. More generally, invariance and contractivity of sets are central properties in modern control theory. Although the first important results on invariance date back to the beginning of the seventies [Bertsekas, 1972], this topic gained considerable interest in more recent years, see in particular the works by Blanchini and coauthors [Blanchini, 1994, Blanchini and Miani, 2008], mainly due to its relation with constrained control and Model Predictive Control.

- My first research line on this topic, main subject of my PhD thesis [Fiacchini, 2010], concerns the conception of methods for computing invariant sets. Different algorithms based on the one-step operator exist for computing invariant and control invariant sets, mainly based on recursion starting from the state constraint set, as in [Blanchini, 1994, Kerrigan, 2001], or those converging to the maximal invariant set from the inside, see [Blanchini, 1992, Blanchini and Miani, 2008]. Other works, see for instance [Gutman and Cwikel, 1986b], [Keerthi and Gilbert, 1987, Mayne and Schroeder, 1997], are based on computing the null-controllable sets that can be proved to converge to the maximal control invariant set. Nonetheless, if for linear systems the methods are rather well assessed, in the more recent years, many efforts have been devoted to extend them to the case of nonlinear ones. During my PhD and the first years of the 2010s I have been working to this problem, providing results on the iterative computation of invariant sets for discrete-time nonlinear systems [Alamo et al., 2009a, Fiacchini et al., 2010a, Fiacchini et al., 2012a], and also for continuous time ones [Fiacchini et al., 2015]. More recently, I have also been addressing the problem of computing control invariant sets for high dimensional linear systems, in [Fiacchini and Almir, 2017b, Fiacchini and Almir, 2018b].



Figure 3.3: Fitorobot and Shell Eco-marathon vehicle

- During the first years following my PhD thesis defence I have been working to the adaptation and application of MPC strategies to mobile robots. In particular, I have been working, together with my colleagues from the **Univerisity of Almeria and Seville**, in Spain, to the problem of control and trajectory tracking for Fitorobot, a mobile robot employed in the agricultural context, see Figure 3.3 left. Several different methods, based on convex optimization, LMI conditions and tube-based MPC have been developed, implemented and tested on the robot. The results have also appeared in several publications, among which some international journal papers [Gonzalez et al., 2010, Gonzalez et al., 2011, González et al., 2011]. This research line has also been developed in collaboration with **G. Millerioux, T. Chambrion and T. Manrique, of CRAN, Nancy**, providing contributions on the computation of invariant sets in presence of time-varying constraints and applying the theoretical results to a real-time model of electrical low consumption vehicle, see Figure 3.3 right. This further collaboration led also to several publications [Manrique et al., 2013, Manrique et al., 2014, Manrique et al., 2015].
- The more recent research line on this topic concerns stochastic MPC and probabilistic invariance. If in the beginning many of the researchers efforts on MPC have been devoted to the robust formulation under worst-case assumptions on the uncertainties, last years saw a shift of the interest to stochastic MPC (SMPC), [Farina et al., 2016, Mesbah, 2016, Mayne, 2018]. SMPC, in fact, permits to take into account the stochastic nature of the uncertainties, exploiting the knowledge of their distribution, and to deal with probabilistic chance constraints, reducing the conservatism inherent to robust MPC. Stochastic MPC found application in building climate regulation, process control, power production and management, vehicle power and steering control, robot path planning, etc, see [Farina et al., 2016] and references therein.

Among the interesting properties of MPC there is its potentiality of ensuring important theoretical features, like recursive feasibility, cost decreasing and constraints satisfaction guarantees, that are the basis on which asymptotic stability and safety properties are proved. The attempts of ensuring these critical features for stochastic MPC, though, did not satisfactorily lead to extend the results proper of deterministic MPC. Moreover, in many of the works concerning the stability analysis of SMPC and invariant set computation the stochastic disturbance is modelled by an independent, identically distributed sequence of random variables. This is the case, for instance, for the methods based on stochastic tube MPC, [Cannon et al., 2011, Hewing and Zeilinger, 2018], SMPC for controlling the average number of constraints violation [Korda et al., 2014a] and probabilistic MPC [Farina et al., 2015].

This research line, developed in collaboration with **T. Alamo from the University of Seville, Spain** and **L. Chaouach from TU Delft, the Netherlands**, provides contributions on the characterization of probabilistic invariant and reachable sets for linear systems in presence of potentially correlated, partially unknown additive noises, in [Fiacchini and Alamo, 2021]. Moreover, the framework of correlated partially unknown noises and the related probabilistic sets have been applied to SMPC to recover recursive feasibility and convergence conditions for this real-world application related case, [Chaouach et al., 2022].

3.1.4 Modeling and control for cancer dynamics

Modeling the dynamics underlying the tumor growth and the related mechanisms such as the tumor-induced vascular development, the angiogenesis, is a key step towards rational optimization of cancer therapy. Several mathematical models representing the tumor evolution, the induced angiogenesis and immune systems interaction appeared in the last decades. In particular, the works [Hahnfeldt et al., 1999, Ergun et al., 2003, d’Onofrio et al., 2009] provide population-based models consisting of low-dimensional systems that permit to qualitatively reproduce the evolution of the tumor mass and its vascularization. Such models are particularly suitable for control purposes, and have been widely employed for control-based therapy synthesis, see [DePillis and Radunskaya, 2005, Matveev and Savkin, 2002, DePillis et al., 2005, Ledzewicz et al., 2008, Ledzewicz et al., 2011] on the application of optimal control, and [Chareyron and Alamir, 2009, Alamir, 2014] on feedback control design. Other models have appeared [Stéphanou et al., 2006, Pons-Salort et al., 2012, Gevertz, 2012, Lesart et al., 2012, Lesart, 2013] whose objective is to recreate the biological processes involved in the tumor growth and in the angiogenesis, up to the cellular level.

This research line concerned the application of set-theoretic and optimization-based methods for developing therapeutic strategies for mathematical models of cancer. This topic has been the objective of the PhD thesis of **R. Riah** and **K. Moussa**, co-directed with **M. Alamir from GIPSA-lab**, that led to several publications [Riah and Fiacchini, 2015, Riah et al., 2015, Riah et al., 2016, Riah et al., 2019, Moussa et al., 2019, Moussa et al., 2020, Moussa et al., 2021, Moussa et al., 2022]. Different models of the effects of chemotherapy and anti-angiogenesis drugs on cancer have been considered, effects that would be used as control actions in the control-based therapy. The objective was to minimize the tumoral size while satisfying constraints related to the health of the patient. Particular attention has been devoted to deal with parametric uncertainties, inherent problem when treating biological systems. Set-theory, optimization-based techniques and probabilistic certification have been applied to infer the domain of attraction and then the robust control for the uncertain models of cancer.



3.1.5 Anesthesia monitoring

This research line is developed in the framework of a Persyval-lab "*équipes-action*" project, that gathers several members, namely **GIPSA-lab, Verimag and TIMC-IMAG/CHUGA Grenoble; LAAS and CHU Rangueil, Toulouse; and the University of Seville**. I am the principal investigator of the project.

General anesthesia plays a fundamental role to provide surgeons with adequate conditions for operation and avoid discomfort or pain for the patient while reducing the negative post-operation effects of anesthesia. In medical practice, anesthesia typically considers the administering of hypnotic and analgesic drugs monitored by the anesthetist by examining reliable indicators, such as the EEG-based spectral features; the bispectral index (BIS), related to the level of consciousness; the

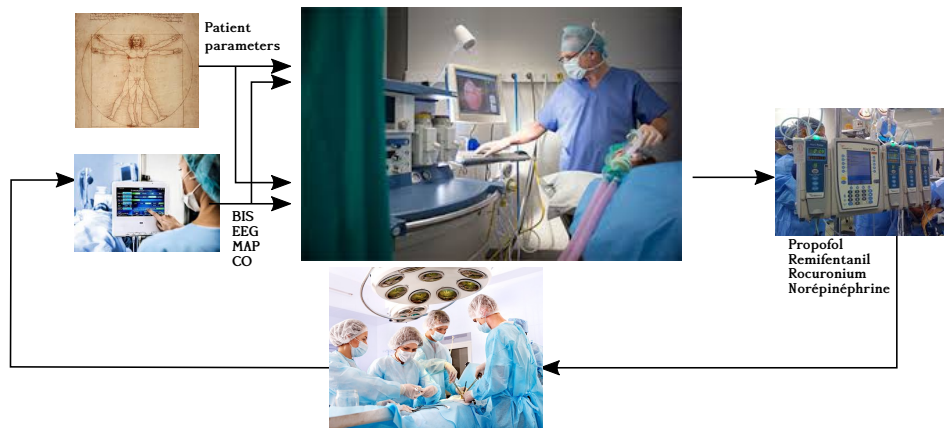

Figure 3.4: Anesthesia monitoring and control

mean arterial pressure (MAP) and heart rate (HR) to monitor the patients hemodynamics state; and, more rarely, the pupillometry, to infer the patient's analgesia level. Furthermore, the anesthesiologist is designated to monitor the hemodynamic evolution, besides to control the patient's level of consciousness and analgesia.

The main objective of anesthesia is then to maintain the desired level of hypnosis, areflexia and analgesia to facilitate the surgeon's tasks by avoiding both drug overdosing and underdosing. Deleterious effects of wrong drug dosing can go, in the short term, from longer post-operative recovery to most severe effects, up to the respiratory and cardiovascular collapse, and in the long term from post-traumatic stress disorder due to partial consciousness during surgical operations, to other long term risks and sequelae on the patient. Although dosing guidelines are provided taking into account the inter-patient pharmacokinetic and pharmacodynamic variability, automated closed-loop control (in particular of Propofol profusion) using the BIS has shown to be of great help not only to increase the control efficiency, but also to preserve the vigilance of anesthetists for potential critical events. The problem consists in practice in designing a control-based drug deliverance protocol to lead the patient to a desired sleep depth as soon as possible but avoiding dangerous drug concentrations. Several approaches have been proposed in the literature, from simple PI control to more complex adaptive control strategies [Bailey and Haddad, 2005, Lemos et al., 2014, Beck, 2015, Zabi et al., 2015, Ionescu et al., 2008] and some of them have been clinically validated [Absalom and Kenny, 2003, van Heusden et al., 2014].

The main objective of this research line is to apply analytical and data-based methods from advanced control theory, formal verification and machine learning to the problems of modelling, monitoring and controlling the anesthetic process. Particular attention is devoted to the unavoidable uncertain nature and variability of the dynamics involved in the process of the anesthesia regulation.

3.1.6 Modeling and control for aluminium production

Aluminium manufacturing is a challenging industrial area based on the Hall-Heroult process, see [Grjotheim, 1982]. This electro-chemical process is carried out by dipping carbon anodes into a cryolite bath solution that contains dissolved alumina (Al_2O_3). A high intensity electric current is applied to the system and the chemical process produces liquid aluminium cumulating at the bottom of the cell, and releases carbon dioxide. During the electrolysis reaction, which is the basis of the process, the anode-cathode distance (ACD) is continuously affected by the liquid aluminium production and the carbon consumption. In fact, the distance between the carbon anode and the liquid metal, acting as cathode, is not constant during the operation due to the chemical reaction.

The carbon anodes being constantly consumed, they are cyclically replaced, while the liquid aluminium laying at the bottom of the pot increases because of the production. Furthermore, perturbations of the current and bath composition can affect the ACD, whose value is critical since a large distance reduces the pot cell efficiency and a small value can cause short-circuits between the produced aluminium and the carbon anode. Unfortunately, though, the hazardous conditions inside the pot impede the use of sensors for continuously measuring the ACD.



Figure 3.5: Aluminium pot cells

Also the dissolved alumina concentration is an important quantity that is not continuously measured. Alumina in powder state is injected in the bath by several feeders distributed along the pot. Low values of alumina concentration can generate deleterious phenomena leading to the production of greenhouse gases, while a large alumina powder quantities can produce in the bath undesirable accumulations of undissolved alumina and lead to cell damages [Biedler, 2003].

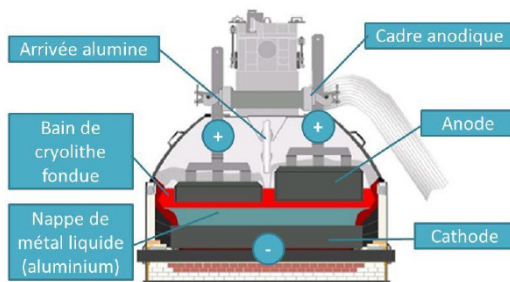

Figure 3.6: Aluminium pot scheme

Therefore, in the context of aluminium production, the modelling, estimation and control challenges mainly come from the unavailability of continuous measurements of the process state, which can lead to inaccurate results and then undesirable operational conditions [Jakobsen et al., 2001]. In this process, in fact, the energy consumption and the production efficiency strongly depend on the ACD and on the alumina concentration, but both quantities cannot be continuously measured. On this topic we have been involved, with **G. Besançon** and **F. Ferrante**, of GIPSA-lab, in

a FUI project coordinated by RioTinto, to model the relevant dynamics involved in the electrolysis process, namely the ACD and the alumina dynamics, to design an appropriate observer and finally a multi-variable control to improve the process efficiency. The FUI project included the funding for a thesis, provided to **Lucas José da Silva Moreira**, and a parallel three-years-lasting contract between GIPSA and Rio Tinto to fund this research line. The thesis led to the publication in international conferences [da Silva Moreira et al., 2020a, da Silva Moreira et al., 2020c, Moreira et al., 2021] and in the journal [da Silva Moreira et al., 2022]. The prolific collaboration with Rio Tinto on topics concerning the aluminium process production is going to continue, thanks to a project co-funded by CNRS "Plan de relance" and Rio Tinto itself, that provides a two-years post-doctoral researcher funding, starting from fall 2022.

3.1.7 Data and learning for control

A research line on which I have been working concerns the application and exploitation of modern numerical tools, like machine learning and nonlinear optimization tools, for modelling and control complex systems through real data handling. In particular, regression and classification methods based on machine learning and nonconvex optimization solvers provide valuable tools to efficiently address several problems of identification and control of real dynamical systems. Particular interest is devoted to the use and handling of real data collected from the analysed process.

This data-based and learning techniques application to real-plant data concerns the exploitation of regression and classification methods based on machine learning approaches in the context of control of dynamical systems. In the paper [Gonzalez et al., 2018] we have been investigating on the capability of estimating and predicting that slippage associated with individual wheels in off-road mobile robots. In the work done in the framework of the industrial project with CALOR ent. (whose details are confidential), the methods based on machine learning have been one of the key approaches to address and solve the observation and control problem. Particular interest has been devoted to the implementation requirements, in terms of computation and real-time embedding requirements.

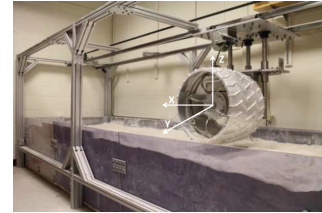

Figure 3.7: MIT single-wheel testbed for slippery estimation

I have also been working on a model identification for fitting the available data at the very beginning of the Covid-19 pandemic spread in France, in [Fiacchini and Alamir, 2021]. The time series concerning the 13 regions of mainland France have been considered for fitting and validating the model. An extremely simple, two-dimensional model with only two parameters demonstrated to be able to reproduce the measured time series involved in Covid-19 spread in early spring 2020. The identification process was based on the daily updated data and on the fitting of a model, highly nonlinear in the systems parameters, by using efficient numerical tools for nonconvex optimization. The obtained results suggest to carefully consider the potential issues of model overfitting, then poor predictive capability, when modelling the pandemic evolution.

Finally, we are currently applying the methods proper of machine learning and non-convex optimization tools in the context of anesthesia. Some databases are available online concerning the evolution of the physiological parameters during surgical operations undergoing with anesthetized patients. Our objectives, together with my colleague **Thao Dang from Verimag, Grenoble** and the PhD student we are directing **Bob Auboin-Pairault**, is to infer and validate a novel machine learning-based model, resorting on the available data, that would permit to better reproduce the patient state evolution, adequately taking into account the patient-dependent parameters variability. Moreover, we are working to the application of learning techniques for early detection of undesirable events during surgery based on the anesthesia-related physiological signals.

3.1.8 Functional observers for discrete-time LPV systems

Another research line, developed in collaboration with **G. Millerioux, of CRAN, Nancy**, concerned functional observers for discrete-time Linear Parameter Varying (LPV) systems. Functional observers aim at reconstructing a particular, often linear, function of the state, possibly of the input as well. They have been widely addressed since the pioneering work [Luenberger, 1966]. A complete framework providing necessary and sufficient conditions for convergence and design procedure and the state of the art in the field are presented in [Chen, 1984, Darouach, 2000, Trinh and Fernando, 2012]. Functional observers have been investigated for some classes of nonlinear systems with unknown inputs. For continuous-time systems, local considerations are used in [Messaoud et al., 2010], sliding mode techniques in [Nikraz, 2010] or LMI-based approaches in [Trinh and Fernando, 2012] taking into account the Lipschitz nature of the nonlinearities. The scarce consideration of nonlinear discrete-time systems with unknown inputs motivated our work. In our papers [Fiacchini and Millerioux, 2012, Fiacchini and Millerioux, 2013], we proposed a dead-beat delayed functional observer for discrete-time LPV systems with unknown inputs. The approach proposed for the design of dead-beat functional observers is based on results of set-theory for control, in particular the concept of invariance spaces strongly related also with the properties of controllability and observability, treated in [Basile and Marro, 1969, Basile and Marro, 1987, Basile and Marro, 1992].

3.1.9 Decentralized systems

This research line concerns decentralized control for multi-agent systems and consensus problems. Multi-agent systems have been used in the last decades to model different dynamics occurring in a large panel of applications going from biology and medicine to transportation, communication and sociology. Moreover, controlling interconnected systems in a decentralized manner [Jadbabaie et al., 2003, Olfati-Saber and Murray, 2004, Ren and Beard, 2005] has advantages related to the computation and communication cost reduction. On the other hand the changes of the network topology may hinder the global coordination goal. To avoid this, works have been treating the problem of the connectivity preservation of the interconnection graph of mobile networks [Bullo et al., 2009, Zavlanos and Pappas, 2008]. Starting from this idea, with the co-author involved in this research line, **C. Morarescu, of CRAN, Nancy**, we presented conditions for network topology preservation, see [Fiacchini and Morărescu, 2012, Fiacchini and Morărescu, 2014a, Morărescu and Fiacchini, 2014]. The main contribution of this research line is the characterization of the control laws preserving a given graph. We considered a networked system with discrete-time dynamics and a given interconnection topology. Our aim was to characterize the decentralized control laws that ensure the satisfaction of the algebraic constraint, by using invariance-based techniques to characterize the conditions assuring that the algebraic constraint holds. The resulting topology preservation conditions are given in form of convex constraints that may be posed in LMI form, then computationally suitable.

3.1.10 Hybrid systems with saturation

Hybrid systems are systems with both continuous-time and discrete-time dynamics. Recently, the interest on hybrid systems has been growing, see [Branicky et al., 1998, Goebel et al., 2004, Prieur et al., 2007, Goebel et al., 2009, Goebel et al., 2012], due to the increasing application of digital devices for the control of real systems, like chemical processes, communications and automotive systems, and also for their flexibility, which allows to overcome some fundamental limitations of classical control [Beker et al., 2004, Prieur et al., 2010, Fichera et al., 2012a, Fichera et al., 2012b, Prieur et al., 2013].

In my work related in particular to the collaboration with **S. Tarbouriech, LAAS, Toulouse, and C. Prieur, GIPSA-lab, Grenoble**, we considered the problem of characterizing both local and global exponential stability for hybrid systems with nested saturations. The proposed methods were based on set-theory and invariance and provided computation-oriented conditions for determining estimations of the domain of attraction for this class of nonlinear hybrid systems. The peculiarity of this approach is that convex analysis and optimization techniques can be often employed to compute the Lyapunov functions and the estimations of the domain of attraction. For instance, the issue of estimating the domain of attraction for saturated systems, in continuous-time and discrete-time, has been dealt with by considering ellipsoids, see [Gomes da Silva Jr. and Tarbouriech, 2001, Hu and Lin, 2002, Hu et al., 2002, Alamo et al., 2005], and polytopes, in [Alamo et al., 2006].

The results of our research on this topic, see [Fiacchini et al., 2011, Fiacchini et al., 2012c, Fiacchini et al., 2014b, Fiacchini et al., 2014a], were the geometrical characterization of saturated functions which permitted to characterize contractivity of ellipsoids and to determine quadratic Lyapunov functions candidates by means of convex constraints. Some results present in literature for continuous-time, as [Hu and Lin, 2002, Alamo et al., 2005], and discrete-time saturated systems, see [Hu et al., 2002], were improved or recovered as particular cases of our approach, see [Fiacchini et al., 2011]. The results have been applied also to obtain computationally suitable conditions for local and global asymptotic stability for hybrid systems with simple and nested saturations.

3.1.11 Unknown input observer for uncertain systems

A side research line concerns the design of unknown input observer for uncertain systems. This line has been developed in collaboration with **Iman Hosseini**, PhD student at the **University of Shiraz, Iran**, which has been visiting GIPSA-lab during around one year, in 2018, under my direction. With Iman, we have been proposing a novel kind of Unknown Input Observer (UIO) called Reset Unknown Input Observer (R-UIO) for state estimation of linear and nonlinear systems in the presence of disturbance using Linear Matrix Inequality (LMI) techniques. The observer stability and the efficiency of the proposed method has been demonstrated by simulation. This research line led to the publication of two journal papers [[Hosseini et al., 2019b](#), [Hosseini et al., 2019a](#)].

3.2 Conclusions

This chapter provided an overview of my past and current research lines and gives a picture of the scientific directions and interests. Three research lines will be detailed in the next chapters. This overview might contribute, though, to give hints on my research activity, aimed at exploiting control theory, with particular attention on set-theory, invariance and optimization methods, to address fundamental issues rising when dealing with real-world dynamical system.

Invariant set computation

Contents

4.1	Control invariant sets in high dimension	36
4.1.1	N-step condition for control invariance	38
4.1.2	State inclusion test	40
4.1.3	Numerical examples	41
4.2	Probabilistic invariance	43
4.2.1	Correlation bound	44
4.2.2	Probabilistic reachable and invariant sets	46
4.2.3	Numerical examples	48
4.3	Conclusions	50

Invariance and contractivity of sets are central properties in modern control theory. Although the first important results on invariance date back to the beginning of the seventies [Bertsekas, 1972], this topic gained considerable interest in more recent years, see in particular the works by Blanchini and coauthors [Blanchini, 1994, Blanchini and Miani, 2008], mainly due to its relation with constrained control and popular optimization-based control techniques as Model Predictive Control, see [Mayne et al., 2000].

Iterative procedures are given for the computation of control invariant sets that permit their practical implementation. Most of those procedures are substantially based on the one-step backward operator that associates to any set the states that can be steered into by an admissible input. Different algorithms based on the one-step operator exist for computing control invariants, based on recursion starting from the state constraint set, as in [Blanchini, 1994, Kerrigan, 2001, Rungger and Tabuada, 2017], or those converging to the maximal invariant set from the inside, see [Blanchini, 1992, Blanchini and Miani, 2008]. Other works are [Gutman and Cwikel, 1986b, Keerthi and Gilbert, 1987, Mayne and Schroeder, 1997, Darup and Mönnigmann, 2014], based on computing the null-controllable sets that can be proved to converge to the maximal control invariant set.

Although the underlining idea of iterative methods for computing control invariant sets applies also for nonlinear systems, see [Fiacchini et al., 2010a, Fiacchini et al., 2012a], and, more recently, methods appeared based on polynomial optimization and SOS tools [Korda et al., 2014b, Henrion and Korda, 2014, Jones and Peet, 2021a, Jones and Peet, 2021b], the computation of invariant sets is often prohibitively complex to be applied in high dimension, even in the linear context. Some constructive approaches are based on Minkowski sum and projection procedure, as in [Keerthi and Gilbert, 1987, Blanchini, 1992, Blanchini et al., 1995], which are hardly applicable in high dimension due to their numerical complexity. Other methods are based on the vertices computation, as [Gutman and Cwikel, 1986b, Lasserre, 1993, Mayne and Schroeder, 1997], but may suffer the combinatorial growth of complexity, then hardly manageable in high dimension too. The numerical complexity has also been addressed by considering linear feedback and ellipsoidal control invariant sets, see the monograph [Boyd et al., 1994], or by fixing the polyhedral set complexity [Blanco et al., 2010, Athanasopoulos et al., 2014, Tahir and Jaimoukha, 2015], at the price of performance and precision degradation.

Another practical issue concerns the recent interest in the characterization and computation of probabilistic reachable sets and probabilistic invariant sets, mainly due to the growing popularity of stochastic Model Predictive Control (SMPC), see [Mesbah, 2016]. Concerning the computation of reachable and invariant sets for deterministic systems and for robust control, i.e. in the worst-case disturbance context, several well-established results are present in the literature, for linear [Blanchini and Miani, 2008, Kolmanovsky and Gilbert, 1998b] and nonlinear systems [Fiacchini et al., 2010b]. In the recent years, some results have been appearing also on probabilistic reachable and invariant sets. The work [Kofman et al., 2012] is completely devoted to the problem of computing probabilistic invariant sets and ultimate bounds for linear systems affected by additive stochastic disturbances. Also the paper [Hewing et al., 2018] presents a characterization of probabilistic sets based on the invariance property in the robust context, whereas [Hewing and Zeilinger, 2019] employs scenario-based methods to design them.

In this chapter, some results on the problem of computing control invariant sets for high dimensional systems are presented [Fiacchini and Almir, 2017a, Fiacchini and Almir, 2018a]. The approach, resulting from a collaboration with **M. Almir** leads to an algorithm for determining control invariant sets that is based on a set inclusion condition involving the N -step set of a polyhedron but does not require to explicitly compute the Minkowski sum nor to have the vertices representation of the sets. Such condition is posed as an LP feasibility problem, hence solvable even in high dimension. Examples that show the low conservatism and the high scalability of the approach are provided. Moreover, recent results on probabilistic invariant sets computations for stochastic linear systems, obtained in collaboration with **T. Alamo** from the University of Seville, are recalled, see [Fiacchini and Alamo, 2021]. In particular, the objectives are probabilistic reachable sets and probabilistic invariant ellipsoids for linear systems excited by disturbances whose realizations are correlated in time. Only bounds on the mean and covariance matrices are required to be known, even stationarity is not necessary. Based on these bounds, the called correlation bound is defined and then employed to determine constructive conditions for computing probabilistic reachable and invariant ellipsoidal sets. The method, resulting in convex optimization problems, is then illustrated through a numerical example, for which the covariance matrices cannot be computed, but bounds exist.

4.1 Control invariant sets in high dimension

The objective of this section is to provide a constructive method to compute a control invariant set for controlled linear systems with constraints on the input and on the state. The purpose is to obtain a polytopic invariant set that could be computed through convex optimization problems. The main aim is to provide a method to obtain admissible control invariant sets for high-dimensional systems, thus no complex computational operations are supposed to be allowed.

The system is given by

$$x(k+1) = Ax(k) + Bu(k) \quad (4.1)$$

where $x(k) \in \mathbb{R}^n$ is the state and $u(k) \in \mathbb{R}^m$ is the input at time $k \in \mathbb{N}$, with constraints

$$x(k) \in X = \{y \in \mathbb{R}^n : Fy \leq f\}, \quad u(k) \in U = \{v \in \mathbb{R}^m : Gv \leq g\}. \quad (4.2)$$

for all $k \in \mathbb{N}$.

Assumption 4.1.1 *The matrix A is non-singular.*

Assumption 4.1.1, not necessary but imposed here to ease the presentation, is not very restrictive. Recall for instance that every discretized linear system with no delay satisfies it. The case of nonsingular A is developed in [Fiacchini and Almir, 2017b], though.

Some basic properties and methods, well assessed in the literature, concerning control invariant sets are recalled hereafter. The one-step backward operator is defined as

$$Q(\Omega, U) = \{x \in \mathbb{R}^n : Ax + Bu \in \Omega, u \in U\}$$

and provides the set of points in the state space that can be mapped into Ω by an admissible input with dynamics (4.1). One way to obtain a control invariant set is by iterating the one-step operator starting from a given initial set Ω , compact, convex set containing the origin in its interior, and then checking whether the union of the sets obtained at iteration k contains Ω . Thus the sketch of the algorithm is:

Algorithm 1 Control invariant

Initialization: given A, B and sets Ω, U , define $\Omega_0 \leftarrow \Omega$ and $k \leftarrow 0$;

Iteration for $k \geq 0$:

$$\Omega_{k+1} = Q(\Omega_k, U)$$

Stop if $\Omega \subseteq \text{co} \left(\bigcup_{j=1}^{k+1} \Omega_j \right)$; denote $N = k + 1$ and

$$\Omega_\infty = \text{co} \left(\bigcup_{k=1}^N \Omega_k \right)$$

Thus, the algorithm computes the preimages of Ω until the stop inclusion condition holds. Considering the set Ω containing the origin, i.e. $0 \in \Omega$, and $Q_k(\Omega, U)$ defined as

$$Q_k(\Omega, U) = \{x \in \mathbb{R}^n : A^k x + \sum_{i=0}^{k-1} A^{k-1-i} B u_{k-i} \in \Omega, u_i \in U \quad \forall i \in \mathbb{N}_k\}, \quad (4.3)$$

the basic algorithm for obtaining a control invariant set consists in searching, given Ω , for the minimal N such that

$$\Omega \subseteq \text{co} \left(\bigcup_{k=1}^N Q_k(\Omega, U) \right). \quad (4.4)$$

Given the initial set Ω , a condition characterizing an invariant set, alternative to (4.4), is the following

$$\Omega \subseteq Q_N(\Omega, U), \quad (4.5)$$

which is equivalent to the fact that every state in $Q_N(\Omega, U)$ can be steered in Ω in exactly N steps. Condition (4.5), which will be referred to as N -step condition in what follows, is just sufficient for (4.4) to hold but it does not require the computation of the convex hull of several sets at every iteration.

To obtain estimations of the maximal control invariant set contained in X , consider

$$Q_k^x(\Omega, U, X) = \{x \in X : A^k x + \sum_{i=0}^{k-1} A^{k-1-i} B u_{k-i} \in \Omega, A^j x + \sum_{i=0}^{j-1} A^{j-1-i} B u_{j-i} \in X \quad \forall j \in \mathbb{N}_k, u_i \in U \quad \forall i \in \mathbb{N}_k\}, \quad (4.6)$$

that is the set of states $x \in X$ for which an admissible sequence of input of length k exists driving the state in Ω in k steps by maintaining the trajectory in X . The resulting control invariant set would then be given by

$$\bar{Q}_N^x(\Omega, U, X) = \text{co} \left(\bigcup_{k=1}^N Q_k^x(\Omega, U, X) \right), \quad (4.7)$$

provided that condition

$$\Omega \subseteq Q_N^x(\Omega, U, X) \quad (4.8)$$

holds. Note that (4.8) is just sufficient but, in general, less complex to be checked than $\Omega \subseteq \bar{Q}_N^x(\Omega, U, X)$.

The value of N for which invariance conditions (4.5) and (4.8) hold depends on the choice of Ω . Clearly, if Ω is a control invariant set, then the conditions hold for all $N \geq 1$. Moreover, for every Ω there exists $\alpha > 0$ and $N \geq 1$ such that $\alpha\Omega$ satisfies (4.5) or (4.8), under mild stabilizability conditions.

The main issue which impedes the application of the algorithm in high dimension is the fact that getting the preimage is equivalent to compute the Minkowski addition of sets, which is a complex operation, being an NP-complete problem, see [Jones et al., 2004, Tiwary, 2008]. Moreover the addition leads to sets whose representation complexity increases. Considering, in fact, two polytopical sets Ω and Δ , their sum has in general more facets and vertices than Ω and Δ . Thus, the algorithm given above requires the computation of the Minkowski sum, hardly manageable in high dimension, and generates polytopes with an increasing number of facets and vertices. Another source of complexity is the convex hull in (4.4) or (4.7), as the explicit computation of the convex hull is a non-convex operation whose complexity grows exponentially with the dimension, see [Berg et al., 2000].

Furthermore, also the vertices representation of the sets is a potential limitation for high dimensional systems, since the number of vertices may grow combinatorially with the dimension. Finally, approaches are provided, for instance in [Keerthi and Gilbert, 1987, Blanchini et al., 1995], that require the computation of the projection of polytopes, operation whose complexity is equivalent to the one of Minkowski sum. As can be seen from the comparison, provided in [Jones et al., 2004], between different projection algorithms, polytope projections are not suitable when projecting on high dimensions. This can be also heuristically checked by computing the projection over an n -dimensional subspace of a randomly generated $2n$ -dimensional polytope. Using the MPT toolbox [Kvasnica et al., 2004], for instance, we needed more than 40 seconds to project a polytope from \mathbb{R}^{10} into a 5-dimensional subspace, more than 15 minutes to project from \mathbb{R}^{12} to \mathbb{R}^6 .

The main objective of this section is to design a method for testing conditions (4.5) and (4.8) and for having a, potentially implicit, representation of sets (4.7) by means of convex optimization problems, then applicable also to relatively high dimensional systems, to obtain control invariant sets, avoiding the vertices representation of the sets and Minkowski sum or polytope projections computation.

4.1.1 N-step condition for control invariance

As noticed above, a first main issue is related to checking whether the sum of several polytopes contains a polytope, see the N -step stop condition (4.5) and (4.8).

Consider first the N -step condition (4.5), characterized by the Minkowski sum of several sets. The explicit definition of the Minkowski sum of sets could be avoided by employing its implicit representation. Indeed, given two polyhedral sets $\Gamma = \{x \in \mathbb{R}^m : Hx \in h\}$ and $\Delta = \{y \in \mathbb{R}^p : Gy \leq g\}$ and $P \in \mathbb{R}^{n \times m}$ and $T \in \mathbb{R}^{n \times p}$ we have that $P\Gamma + T\Delta = \{x \in \mathbb{R}^n : x = Py + Tz, Hy \leq h, Gz \leq g\}$. Thus, the explicit hyperplane or vertex representation of the sum can be replaced by the implicit one, given by the projection of a polyhedron in higher dimension. On the other hand, one might wonder if the stop condition $\Omega \subseteq Q_N(\Omega, U)$ could be checked without the explicit representation of $Q_N(\Omega, U)$.

The first hint to do is that the inclusion condition is testable through a set of LP problems provided the vertices of Ω are available. Such an assumption is not very restrictive, since Ω is a design parameter that could be determined such that both the hyperplane and vertices represen-

tation should be available, a box for instance. Nevertheless, and since we are aiming at invariant sets for high dimensional systems, the use of vertices should be avoided if possible. Consider for instance, in fact, a system with $n = 20$. The unit box in \mathbb{R}^{20} is characterized by 40 hyper-planes, but it has $2^{20} \simeq 10^6$ vertices. Then checking if it is contained in a set could require to solve more than a million of LP problems.

We consider then the possibility of testing whether a polyhedron is included in the sum of polyhedra by employing only their hyperplane representations and without the explicit representation of the sum of sets. The following result, based on the Farkas lemma and widely used on set theory and invariant methods for control, is useful for this purpose.

Lemma 4.1.1 *Two polyhedral sets $\Gamma = \{x \in \mathbb{R}^n : Hx \leq h\}$, with $H \in \mathbb{R}^{p \times n}$, and $\Delta = \{x \in \mathbb{R}^n : Gx \leq g\}$, with $G \in \mathbb{R}^{q \times n}$, satisfy $\Gamma \subseteq \Delta$ if and only if there exists a non-negative matrix $T \in \mathbb{R}^{q \times p}$ such that $TH = G$ and $Th \leq g$.*

Consider now the stop condition (4.5), which is suitable for applying the Lemma 4.1.1, as illustrated below.

The main issue for applying Lemma 4.1.1 is the fact that obtaining the explicit hyperplane representation of the set at right-hand side of (4.5) is numerically hardly affordable, mainly in relatively high dimension. In fact, given two polyhedra $\Gamma \subseteq \mathbb{R}^m$ and $\Delta \subseteq \mathbb{R}^p$, to determine L and l such that $P\Gamma + Q\Delta = \{x \in \mathbb{R}^n : Lx \leq l\}$ is an NP-complete problem, see [Tiwary, 2008]. Nevertheless, a sufficient condition in form of LP feasibility problem is given below.

Theorem 4.1.1 *Consider $\Omega = \{x \in \mathbb{R}^n : Hx \leq h\}$ and U as in (4.2), with $H \in \mathbb{R}^{n_h \times n}$ and $G \in \mathbb{R}^{n_g \times m}$, and suppose that $0 \in \Omega$ and $0 \in U$. Then the set*

$$\bar{Q}_N(\Omega, U) = \text{co} \left(\bigcup_{k=1}^N Q_k(\Omega, U) \right) \quad (4.9)$$

is a control invariant set if there exist $T \in \mathbb{R}^{n_{\bar{g}} \times n_h}$ and $M \in \mathbb{R}^{\bar{n} \times \bar{n}}$, with $n_{\bar{g}} = n_h + Nn_g$ and $\bar{n} = n + Nm$, such that

$$\begin{cases} T\bar{H} = \bar{G}M \\ Th \leq \bar{g} \\ [I \ 0 \ 0 \ \dots \ 0] = [I \ 0 \ 0 \ \dots \ 0]M \end{cases} \quad (4.10)$$

hold with

$$\bar{G} = \begin{bmatrix} HA^N & HB & HAB & \dots & HA^{N-1}B \\ 0 & G & 0 & \dots & 0 \\ 0 & 0 & G & \dots & 0 \\ \dots & \dots & \dots & \dots & \dots \\ 0 & 0 & 0 & \dots & G \end{bmatrix}, \quad \bar{g} = \begin{bmatrix} h \\ g \\ g \\ \dots \\ g \end{bmatrix} \quad (4.11)$$

$$\bar{H} = [H \ 0 \ 0 \ \dots \ 0]$$

where $\bar{G} \in \mathbb{R}^{n_{\bar{g}} \times \bar{n}}$, $\bar{g} \in \mathbb{R}^{n_{\bar{g}}}$, and $\bar{H} \in \mathbb{R}^{n_h \times \bar{n}}$.

The result given above can be directly extended to the problem in presence of constraints on the state.

Theorem 4.1.2 *Consider $\Omega = \{x \in \mathbb{R}^n : Hx \leq h\}$ and X and U as in (4.2), with $H \in \mathbb{R}^{n_h \times n}$, $F \in \mathbb{R}^{n_f \times n}$, $G \in \mathbb{R}^{n_g \times m}$, and suppose that $0 \in \Omega$, $0 \in X$ and $0 \in U$. Then the set $\bar{Q}_N^x(\Omega, U, X)$ as in (4.7) is a control invariant set contained in X if there exist $T \in \mathbb{R}^{n_{\bar{g}} \times n_h}$ and $M \in \mathbb{R}^{\bar{n} \times \bar{n}}$, with*

$n_{\bar{g}} = n_h + Nn_g + Nn_f$ and $\bar{n} = n + Nm$, such that (4.10) holds with

$$\bar{G} = \begin{bmatrix} HA^N & HB & HAB & \dots & HA^{N-1}B \\ 0 & G & 0 & \dots & 0 \\ 0 & 0 & G & \dots & 0 \\ \dots & \dots & \dots & \dots & \dots \\ 0 & 0 & 0 & \dots & G \\ \hline FA^N & FB & FAB & \dots & FA^{N-1}B \\ FA^{N-1} & 0 & FB & \dots & FA^{N-2}B \\ \dots & \dots & \dots & \dots & \dots \\ FA & 0 & 0 & \dots & FB \\ F & 0 & 0 & \dots & 0 \end{bmatrix}, \quad \bar{g} = \begin{bmatrix} h \\ g \\ g \\ \dots \\ g \\ f \\ f \\ \dots \\ f \\ f \end{bmatrix} \quad (4.12)$$

$$\bar{H} = \begin{bmatrix} H & 0 & 0 & \dots & 0 \end{bmatrix}$$

where $\bar{G} \in \mathbb{R}^{n_{\bar{g}} \times \bar{n}}$, $\bar{g} \in \mathbb{R}^{n_{\bar{g}}}$, and $\bar{H} \in \mathbb{R}^{n_h \times \bar{n}}$.

Given the sets Ω, U and X , to obtain the greatest multiple of Ω such that (4.8) holds, that is the greatest $\alpha \in \mathbb{R}$ such that

$$\alpha\Omega \subseteq Q_N^x(\alpha\Omega, U, X), \quad (4.13)$$

is equivalent to compute the smallest nonnegative β , with $\beta = \alpha^{-1}$, such that

$$\Omega \subseteq Q_N^x(\Omega, \beta U, \beta X).$$

This consists in replacing g with βg in (4.12) and leads to the following LP problem in T, M and β

$$\begin{aligned} \alpha^{-1} = \beta &= \min_{\beta \in \mathbb{R}_+} \gamma \\ \text{s.t. } & T\bar{H} = \bar{G}M \\ & Th \leq \gamma\hat{g} + \tilde{g} \\ & \begin{bmatrix} I & 0 & 0 & \dots & 0 \end{bmatrix} = \begin{bmatrix} I & 0 & 0 & \dots & 0 \end{bmatrix} M \end{aligned} \quad (4.14)$$

with $\hat{g} = (0, g, g, \dots, g, f, \dots, f, f)$ and $\tilde{g} = (h, 0, 0, \dots, 0)$. Clearly, if Ω is a control invariant set, then the greatest α satisfying (4.13) is not smaller than 1.

Note that directly maximizing α would yield to replace h by αh in (4.10) and (4.12) and then to a nonlinear optimization problem. Analogous computational considerations hold for the case of absence of state constraints, as in Theorem 4.1.1, which is a particular case of Theorem 4.1.2 with $X = \mathbb{R}^n$.

4.1.2 State inclusion test

In the previous section, a condition for (4.8) to hold is given that does not require the computation of the preimage sets $Q_N^x(\Omega, U, X)$, then avoiding the computation of Minkowski addition, see Theorem 4.1.2. Once $\alpha\Omega$ is computed by solving (4.14), one possible choice to obtain a control invariant set is given by

$$\bar{\Omega}^x = \text{co} \left(\bigcup_{k=1}^N \Omega_k^x \right) \quad \text{with} \quad \Omega_k^x = Q_k^x(\alpha\Omega, U, X). \quad (4.15)$$

To have an explicit representation of $\bar{\Omega}^x$ requires to compute the convex hull of the union of several sets, each one given by the Minkowski sum of sets, but the convex hull operation is numerically demanding. Hereafter we provide a convex condition to check if a given $x \in \mathbb{R}^n$ belongs to the invariant set $\bar{\Omega}^x$ without computing it explicitly.

The theorem below provides a representation of the control invariant $\bar{\Omega}^x$ in terms of linear equalities and inequalities.

Theorem 4.1.3 *Let Assumption 4.1.1 hold. Consider $\Omega = \{x \in \mathbb{R}^n : Hx \leq h\}$ bounded, X and U as in (4.2), with $H \in \mathbb{R}^{n_h \times n}$, $F \in \mathbb{R}^{n_f \times n}$, $G \in \mathbb{R}^{n_g \times m}$, and suppose that $0 \in \Omega$, $0 \in X$, $0 \in U$ and U is bounded. Given α solution of (4.14) then the set $\bar{\Omega}^x$ defined by (4.15) can be written as follows*

$$\begin{aligned} \bar{\Omega}^x = \{x \in \mathbb{R}^n : & x = \sum_{k=1}^N z_k; \\ & HA^k z_k + \sum_{i=0}^{k-1} HA^{k-1-i} Bv_{k,k-i} \leq \alpha \lambda_k h, \forall k \in \mathbb{N}_N; \\ & FA^j z_k + \sum_{i=0}^{j-1} FA^{j-1-i} Bv_{k,j-i} \leq \lambda_k f, \forall j \in \mathbb{N}_k, \forall k \in \mathbb{N}_N; \\ & Fz_k \leq \lambda_k f, \forall k \in \mathbb{N}_N; \quad Gv_{k,i} \leq \lambda_k g \forall i \in \mathbb{N}_k, \forall k \in \mathbb{N}_N; \\ & \lambda \geq 0, \sum_{k=1}^N \lambda_k = 1\}. \end{aligned} \quad (4.16)$$

Theorem 4.1.3 implies that checking if $x \in \bar{\Omega}^x$ resorts to solve an LP feasibility problem in the variables $x, z_k, v_{k,i}, \lambda_k$ for all $i \in \mathbb{N}_k$ and $k \in \mathbb{N}_N$, then in a space of dimension $n + Nn + 0.5N(N+1)m + N$. Such a representation is particularly suitable to be used in optimization-based control, as model predictive control for instance, since it reduces to enforcing the linear constraints characterizing $\bar{\Omega}^x$.

4.1.3 Numerical examples

The different results presented in this section are illustrated through numerical examples. The optimization problems are solved using YALMIP interface [Löfberg, 2004] and Mosek optimizer [MOSEK ApS, 2015] on an Intel® Core™ i7-6600U CPU @ 2.60GHz × 4 processor laptop with 16GB of RAM.

4.1.3.1 Example

Here we compare the computational burden required to check the invariant condition (4.13) by solving (4.12)-(4.14) with an alternative approach based on known properties of computational geometry. First we describe this approach. Suppose that both the hyper-planes and the vertices representation of Ω are available. This assumption, not needed for our method that only requires the H-representation, could be reasonably posed since Ω can be arbitrary chosen, and then fixed to be the unitary box, i.e. $\Omega = \mathbf{B}^n$. Then, the 2^n vertices can be easily obtained, which is not the case for general polytopes. Thus, the exact maximal α such that (4.13) is satisfied is given by

$$\begin{aligned} \alpha^* = \max_{\alpha, u_{i,j}} \alpha \\ \text{s.t. } \tilde{G} \cdot (\alpha v_j, u_{1,j}, \dots, u_{N,j},) \leq \alpha \tilde{g} + \hat{g}, \quad \forall j \in \mathbb{N}_{2^n} \end{aligned} \quad (4.17)$$

where v_j is the j -th vertex, with $j \in \mathbb{N}_{2^n}$, and \tilde{G}, \tilde{g} and \hat{g} are defined in and below Theorem 4.1.2. The constraints in the LP problem (4.17) impose that every vertex of $\alpha\Omega$ is contained in $Q_N^x(\alpha\Omega, U, X)$ and their number is equal to the number of vertices of Ω , hence exponentially growing with the system dimension.

The exact maximal α^* solution of (4.17) and the α obtained by solving (4.14) with (4.12) are computed for randomly generated controllable systems with real eigenvalues with increasing n and $m = \lceil n/2 \rceil$. The sets are $\Omega = \mathbf{B}^n, U = 10\mathbf{B}^m$ and $X = 100\mathbf{B}^n$ and $N = 2$. The computation times are given in Figure 4.1 in function of the state dimension n .

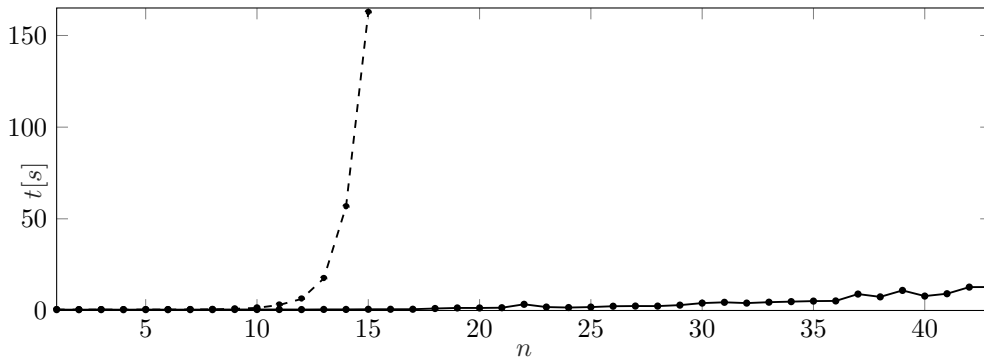

Figure 4.1: Computation times in seconds to solve (4.17), in dashed line, and to solve (4.14) with (4.12), in solid line, in function of the state dimension n .

Note that the proposed method permits to check the invariance condition up to a 40 dimensional system with 20 inputs in less than 12 seconds, while the alternative approach needs more than 160s for $n = 15$.

In Figure 4.2 we report the values of α obtained by solving (4.14) for 1000 randomly generated systems with n between 1 and 12 and also the normalized mismatch with respect to α^* given by (4.17), i.e. $|\alpha - \alpha^*|/\alpha^*$, in logarithmic scale. It can be noticed that the approximation error is several order of magnitude smaller than the values of α , in most of the cases included between 10^{-4} and 10^{-12} , which might be due to the numerical precision rather than to real inaccuracy.

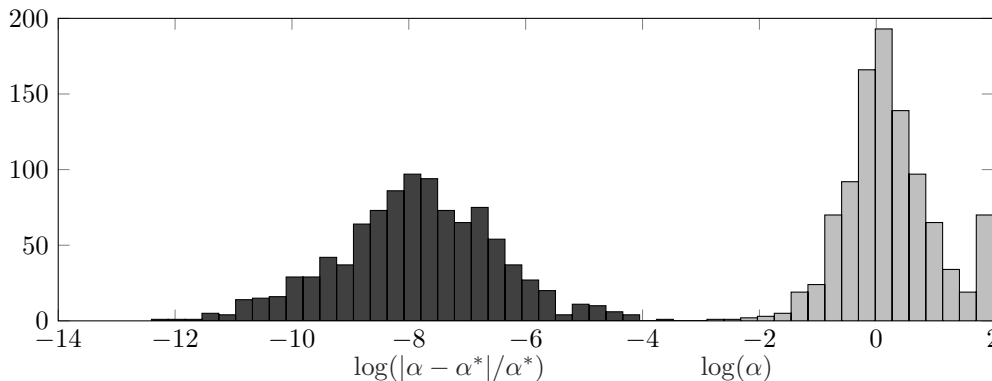

Figure 4.2: Histograms of the values of $\log(\alpha)$, in light gray, and $\log(|\alpha - \alpha^*|/\alpha^*)$, in dark gray, over 1000 tests.

Finally, the Minkowski sum has been employed to compute $Q_N^x(\alpha\Omega, U, X)$ a posteriori, for evaluating its computational cost, but we could not go further than $n = 4$.

4.1.3.2 Example

We apply now the proposed method to an high dimensional system, in particular with $n = 30$ and $m = 15$ with horizons $N = 5, 10$. To provide some hints on the conservatism of the control invariant obtained with respect to the maximal control invariant set, we build a system for which the latter can be computed. Indeed the classical algorithms for computing the maximal control invariant set are too computationally demanding to be applied to high dimensional systems in general. Then, a specific structure has to be imposed to the system dynamics for computing the maximal control invariant set to be compared with our results. In particular, we consider system

(4.1) with

$$A = P^{-1} \begin{bmatrix} A_1 & 0 & \dots & 0 \\ 0 & A_2 & \dots & 0 \\ \dots & \dots & \dots & \dots \\ 0 & 0 & \dots & A_{15} \end{bmatrix} P, \quad B = P^{-1} \begin{bmatrix} B_1 & 0 & \dots & 0 \\ 0 & B_2 & \dots & 0 \\ \dots & \dots & \dots & \dots \\ 0 & 0 & \dots & B_{15} \end{bmatrix} \quad (4.18)$$

where $A_i \in \mathbb{R}^{2 \times 2}$ and $B_i \in \mathbb{R}^2$, for $i \in \mathbb{N}_{15}$, are matrices whose entries are randomly generated such that all A_i have unstable poles and the pairs (A_i, B_i) are controllable and the maximal control invariant is obtained, as illustrated below, after 5 iterations at most. The latter requirement has been introduced for sets convergence reasons. The matrix $P \in \mathbb{R}^{30 \times 30}$ is a randomly generated non-singular matrix. Figure 4.3 provides a graphical representation of A and B , for which the maximal values (15.303 for A and 49.0516 for B) are depicted in white, the minimal ones (-13.4866 for A and -60.4621 for B) are drawn in black, the other values are proportional degree of gray. The matrices are not sparse, not a single null entry is present either in A or B , and are available under request.

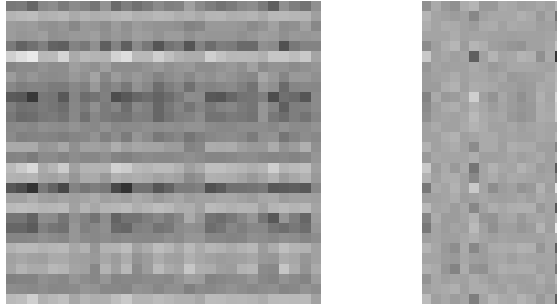

Figure 4.3: Graphical representation of matrices A and B .

Thus, the dynamics of system with state $y = Px$, is controllable and it is, in practice, composed by 15 decoupled two-dimensional subsystems with one control input each. Hence, the maximal control invariant set in the space for the overall system in y , denoted Σ , is given by the Cartesian product of the maximal control invariant sets of the 15 subsystems. That is $\Sigma = \prod_{i=1}^{15} \Sigma_i$ where Σ_i are the maximal control invariant set in $10\mathcal{B}^2$ for the i -th subsystem with input bound $10\mathcal{B}^2$. Hence Σ can be computed by computing Σ_i , being (A_i, B_i) a two-dimensional controllable system, for all $i \in \mathbb{N}_{15}$. Therefore, $P^{-1}\Sigma \subseteq \mathbb{R}^{30}$ is the maximal control invariant set for the system (4.1) in x with (4.18). After computing $P^{-1}\Sigma$, the linear problem (4.14) has been solved to obtain $\bar{\Omega}^x$ with $N = 5, 10$ and sets $\Omega = P^{-1}\mathbf{B}^{30}$, $U = 10\mathbf{B}^{15}$ and $X = 10P^{-1}\mathbf{B}^{30}$.

To quantify the difference between the maximal control invariant set $P^{-1}\Sigma$ and the set $\bar{\Omega}^x$, 100 vectors $v \in \mathbb{R}^n$ are generated randomly. Then, (a lower approximation of) the maximal values of r_Σ and r_Ω are computed such that $r_\Sigma v \in P^{-1}\Sigma$ and $r_\Omega v \in \bar{\Omega}^x$, through dichotomy method. In practice, we search for (approximations of) the intersections between the ray $v_r = \{rv \in \mathbb{R}^n : r \geq 0\}$ and the boundaries of the sets $P^{-1}\Sigma$ and $\bar{\Omega}^x$. The ratio between r_Ω/r_Σ is an indicator of the mismatch between the maximal control invariant set $P^{-1}\Sigma$ and $\bar{\Omega}^x$, the closer to one, the closer are the intersections between the ray v_r and the two sets.

Figure 4.4 shows the histograms of the ratio r_Ω/r_Σ for $N = 5, 10$. As expected, the higher is the horizon N , the closer are the sets Σ and $\bar{\Omega}^x$.

4.2 Probabilistic invariance

The results presented in this section aim to characterize and compute, via convex optimization, outer bounds of probabilistic reachable sets and probabilistic invariant ellipsoids for linear systems

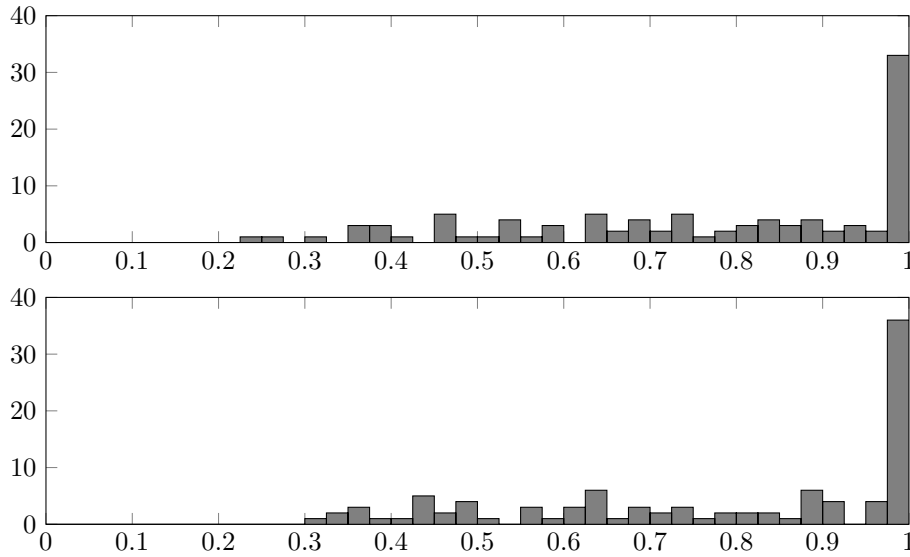

Figure 4.4: Histograms of the values r_Ω/r_Σ for $N = 5, 10$ for a systems with $n = 30$ and $m = 15$.

excited by disturbances whose realizations are correlated in time. Only bounds on the mean and covariance matrices are required to be known, even stationarity is not necessary. Based on these bounds, the called correlation bound is defined and then employed to determine constructive conditions for computing probabilistic reachable and invariant ellipsoidal sets. The method, resulting in convex optimization problems, is then illustrated through a numerical example, for which the covariance matrices cannot be computed, but bounds exist.

4.2.1 Correlation bound

Consider first the nonlinear system $x_{k+1} = f(x_k, d_k)$, where $x_k \in \mathbb{R}^n$ is the state and d_k represents time-varying uncertain parameters and disturbances. A common way of approximating the nonlinear dynamics is by means of a model of the form $x_{k+1} = Ax_k + w_k$ where w_k is an additive term accounting for the cumulative effects of the modelling errors and the past values of d_k . In this context it is unrealistic to assume that w_k is not correlated with the previous values w_j , with $j \leq k$, especially if j is close to k . Even an assumption on stationarity of w_k is often hardly justifiable since, due to the possibly nonlinear nature of $f(\cdot, \cdot)$, the statistical properties of w_k depend also on the current state x_k and therefore might be time varying. To better deal with these issues, the case of additive uncertainty w_k that is correlated in time and not necessarily stationary is considered.

Consider the discrete-time system

$$x_{k+1} = Ax_k + w_k, \quad (4.19)$$

where $x_k \in \mathbb{R}^n$ is the state and $w_k \in \mathbb{R}^n$ an additive disturbance given by a sequence of random variables that are supposed to be correlated in time.

Here, the only assumptions on the disturbance w_k is that its time-dependent mean is bounded, a bound on $E\{w_k w_k^T\}$ exists, and the covariance between w_i and w_j exponentially vanishes with $|j - i|$.

Assumption 4.2.1 *There exist $m, b, \gamma \in \mathbb{R}$, with $\gamma \in [0, 1)$, such that the sequence w_k satisfies:*

$$\mu_k^\top \mu_k \leq m, \quad \forall k \in \mathbb{N}, \quad (4.20)$$

$$\|\text{cov}(w_i, w_j)\|_2^2 \leq b\gamma^{j-i}, \quad \forall i \leq j, \quad (4.21)$$

with $E\{w_k\} = \mu_k$ and $\text{cov}(w_i, w_j) = E\{(w_i - \mu_i)(w_j - \mu_j)^\top\}$.

Note that no assumption on $\{w_k\}_{k \in \mathbb{N}}$ is posed other than the existence of bounds on the mean and the covariance matrices. Neither weak stationarity is required, as both the mean and the covariance matrices are allowed to be functions of time. This aspect might be crucial in practice, as no exact knowledge of the matrices nor guarantee of stationarity are often available.

Proposition 4.2.1 *If Assumption 4.2.1 is satisfied, then non-negative $\alpha, \beta, \gamma \in \mathbb{R}$ and $\tilde{\Gamma} \in \mathcal{S}^n$ exist, with $\gamma \in [0, 1)$ and $\tilde{\Gamma} \succ 0$, such that*

$$\Gamma_{k,k} \preceq \tilde{\Gamma}, \quad \forall k \in \mathbb{N}, \quad (4.22)$$

$$\Gamma_{i,j} \tilde{\Gamma}^{-1} \Gamma_{i,j}^\top \preceq (\alpha + \beta\gamma^{j-i})\tilde{\Gamma}, \quad \forall i \leq j, \quad (4.23)$$

hold, with $\Gamma_{i,j} = E\{w_i w_j^\top\}$, for all $i, j \in \mathbb{N}$.

Note that, although the existence of bounds (4.20) and (4.21) on the mean and covariance matrices is the only posed assumption, it is not necessary to know them. The results presented here only require, in fact, the knowledge of bounds (4.22) and (4.23), that can be estimated from data.

The following definition of correlation bound encloses the key concept that permits to characterize and compute probabilistic reachable and invariant sets for linear systems affected by correlated disturbance.

Definition 4.2.1 (Correlation bound) *The random sequence $\{w_k\}_{k \in \mathbb{Z}}$ is said to have a correlation bound Γ_w for matrix A if the recursion $z_{k+1} = Az_k + w_k$ with $z_0 = 0$, satisfies*

$$AE\{z_k z_k^\top\} + E\{w_k z_k^\top\}A^\top + E\{w_k w_k^\top\} \preceq \Gamma_w, \quad (4.24)$$

or, equivalently

$$E\{z_{k+1} z_{k+1}^\top\} \preceq AE\{z_k z_k^\top\}A^\top + \Gamma_w, \quad (4.25)$$

for all $k \geq 0$.

It will be proved in the next section that, if the matrix A in (4.19) is Schur, i.e. $\rho(A) < 1$, and Assumption 4.2.1 holds, then a correlation bound exists.

4.2.1.1 Computation of a correlation bound

As it will be shown in the subsequent sections, a correlation bound permits to determine sequences of probabilistic reachable sets and probabilistic invariant sets. For this, it is necessary to provide a condition and a method to obtain a correlation bound. Such a condition is presented in the following proposition.

Proposition 4.2.2 *Given the system (4.19) with $\rho(A) < 1$, let $\{w_k\}_{k \in \mathbb{Z}} \in \mathbb{R}^n$ be a random sequence such that conditions (4.22) and (4.23) hold with $\tilde{\Gamma} \succ 0$, $\alpha \geq 0$, $\beta \geq 0$ and $\gamma \in (0, 1)$. Given $\eta \in [\rho(A)^2, 1)$, consider $\varphi \geq 1$ and $S \in \mathcal{S}^n$ satisfying*

$$S \preceq \tilde{\Gamma} \preceq \varphi S, \quad ASA^\top \preceq \eta S. \quad (4.26)$$

Then for every $p \in (\eta, 1)$, the matrix

$$\Gamma_w = \left(\alpha\varphi \frac{\eta}{p-\eta} + \beta\varphi \frac{\gamma\eta}{p-\gamma\eta} + \frac{p}{1-p} + 1 \right) \tilde{\Gamma} \quad (4.27)$$

is a correlation bound for the sequence $\{w_k\}_{k \in \mathbb{Z}}$ and matrix A .

Note that, as formally stated in the following corollary, Propositions 4.2.1 and 4.2.2 imply that, if $\rho(A) < 1$, then Assumption 4.2.1 ensures the existence of a correlation bound.

Corollary 4.2.1 *If Assumption 4.2.1 holds and matrix A in (4.19) is such that $\rho(A) < 1$, then the random sequence $\{w_k\}_{k \in \mathbb{Z}}$ has a correlation bound for matrix A .*

The result of Proposition 4.2.2 is used hereafter to design an optimization-based procedure to compute the tightest correlation bound. To obtain the sharpest bound, the parameter multiplying $\tilde{\Gamma}$ in (4.27) has to be minimized. Note first that such parameter is monotonically increasing with φ and η , for $\varphi \geq 1$ and $\eta \in [\rho(A)^2, 1)$. Nevertheless, the minimizing pair φ and η is not evident, even for a given p , due to the constraint (4.26). One possibility is to grid the interval $[\rho(A)^2, 1)$ of η and then obtain, for every value of η on the grid, the optimal φ and p . To do so, one should first fix η and then solve the semidefinite programming problem

$$\begin{aligned} (\varphi^*, S^*) = \min_{\varphi, S} \quad & \varphi \\ \text{s.t.} \quad & S \preceq \tilde{\Gamma} \preceq \varphi S \\ & ASA^\top \preceq \eta S. \end{aligned}$$

Note now that the parameter multiplying $\tilde{\Gamma}$ in (4.27) is a convex function of p . In fact, $a/(p-a)$ is zero if $a = 0$ and it is finite, convex and decreasing for $p \in (a, +\infty)$ if $a > 0$, whereas $p/(1-p)$ is finite, convex and increasing for $p \in (-\infty, 1)$. Then, the minimum of the function multiplying $\tilde{\Gamma}$ exists and is unique in $(\eta, 1)$. This means that, once φ and η are fixed, the value of p that minimizes the parameter multiplying $\tilde{\Gamma}$ in (4.27) can be computed by solving the following convex optimization problem in a scalar variable:

$$\begin{aligned} p^*(\eta, \varphi) = \min_p \quad & \alpha\varphi \frac{\eta}{p-\eta} + \beta\varphi \frac{\gamma\eta}{p-\gamma\eta} + \frac{p}{1-p} \\ \text{s.t.} \quad & \eta < p < 1. \end{aligned}$$

Finally, Γ_w can be computed by using in (4.27) the minimal value of the parameter multiplying $\tilde{\Gamma}$ over the optimal ones obtained for the different η on the grid.

Remark 4.2.1 *Note that γ could also be bigger than or equal to 1: this would lead to an (although non realistic) increasingly correlated disturbance. The limit would exist provided that η is smaller than the inverse of γ , for all $p \in (\gamma\eta, 1)$. The case of $\gamma = 1$ is realistic, for instance for the case of constant disturbances, and can be modelled by the constant term α .*

The dependence of the bound (4.27) on the parameter φ can be removed by avoiding using the bound $S \preceq \varphi\tilde{\Gamma}$. The corollary below, providing a potentially less conservative correlation bound, follows straightforwardly.

Corollary 4.2.2 *Under the hypothesis of Proposition 4.2.2, for every $p \in (\eta, 1)$, the matrix*

$$\Gamma_w = \left(\frac{\alpha\varphi\eta}{p-\eta} + \frac{\beta\varphi\gamma\eta}{p-\gamma\eta} \right) S + \left(\frac{p}{1-p} + 1 \right) \tilde{\Gamma} \quad (4.28)$$

is a correlation bound for matrix A .

Condition (4.28) provides a further degree of freedom, i.e. the matrix S , that can be used to improve the bound.

4.2.2 Probabilistic reachable and invariant sets

Based on the correlation bound, conditions for computing probabilistic reachable and invariant sets are presented. First, two properties are given that are functional to the purpose.

Property 4.2.1 For every $r > 0$ and every $\tilde{\Gamma}, \Sigma \in \mathcal{S}^n$ such that $\tilde{\Gamma} \succeq 0$ and $\Sigma \succ 0$, it holds

$$\mathcal{E}(A\tilde{\Gamma}A^\top + \Sigma, r) \subseteq A\mathcal{E}(\tilde{\Gamma}, r) + \mathcal{E}(\Sigma, r). \quad (4.29)$$

The result in Property 4.2.1 is used in the following one to characterize bounds on the covariance matrices and probabilities of the system trajectory.

Property 4.2.2 Suppose that the random sequence $\{w_k\}_{k \in \mathbb{N}}$ has a correlation bound $\Gamma_w \succ 0$ for matrix A with $\rho(A) < 1$. Given $r > 0$, consider the system $z_{k+1} = Az_k + w_k$ with $z_0 = 0$ and the recursion

$$\Gamma_{k+1} = A\Gamma_k A^\top + \Gamma_w \quad (4.30)$$

with $\Gamma_0 = 0 \in \mathbb{R}^{n \times n}$. Then,

- (i) $\mathbb{E}\{z_k z_k^\top\} \preceq \Gamma_k, \quad \forall k \geq 0,$
- (ii) $\Pr\{z_k \in \mathcal{E}(\Gamma_k, r)\} \geq 1 - \frac{n}{r}, \quad \forall k \geq 1,$
- (iii) $\mathcal{E}(\Gamma_k, r) \subseteq \mathcal{E}(\Gamma_{k+1}, r) \subseteq A\mathcal{E}(\Gamma_k, r) + \mathcal{E}(\Gamma_w, r), \quad \forall k \geq 1.$

4.2.2.1 Probabilistic reachable sets

The simplest confidence regions are ellipsoids, that have been widely used in the context of MPC, see, for example, [Cannon et al., 2011, Hewing and Zeilinger, 2018]. The definition of probabilistic reachable sets is recalled.

Definition 4.2.2 (Probabilistic reachable set) It is said that $\Omega_k \subseteq \mathbb{R}^n$ with $k \in \mathbb{N}$ is a sequence of probabilistic reachable sets for system (4.19), with violation level $\varepsilon \in [0, 1]$, if $x_0 \in \Omega_0$ implies $\Pr\{x_k \in \Omega_k\} \geq 1 - \varepsilon$ for all $k \geq 1$.

A condition for a sequence of sets to be probabilistic reachable sets is presented, in terms of correlation bound. Analogous results for correlated disturbance can be found in [Hewing et al., 2018].

Proposition 4.2.3 Suppose that the random sequence $\{w_k\}_{k \in \mathbb{N}}$ has a correlation bound $\Gamma_w \succ 0$ for matrix A with $\rho(A) < 1$. Given $r > 0$, consider the system (4.19) and the recursion (4.30) with $x_0 = 0 \in \mathbb{R}^n, \Gamma_0 = 0 \in \mathbb{R}^{n \times n}$. Then the sets defined as

$$\mathcal{R}_{k+1} = A\mathcal{R}_k + \mathcal{E}(\Gamma_w, r), \quad (4.31)$$

for all $k \in \mathbb{N}$, and $\mathcal{R}_0 = \{0\}$ are probabilistic reachable sets with violation level n/r for every $r > 0$.

The sets $\mathcal{E}(\Gamma_k, r)$ are probabilistic reachable sets with violation level n/r , which are less conservative than \mathcal{R}_k and simply determined by iteration (4.30). If, nonetheless, sets \mathcal{R}_k and $\mathcal{E}(\Gamma_k, r)$ require to be computed for every $k \in \mathbb{N}$, a sequence of reachable sets determined by a unique matrix is given below.

Proposition 4.2.4 Suppose that the random sequence $\{w_k\}_{k \in \mathbb{Z}}$ has a correlation bound $\Gamma_w \succ 0$ for matrix A . If $W \in \mathcal{S}^n$ is such that $W \succ 0$ and

$$AWA^\top \preceq \lambda^2 W, \quad (4.32)$$

$$\Gamma_w \preceq (1 - \lambda)^2 W, \quad (4.33)$$

with $\lambda \in [0, 1)$, then $\Omega_k = \mathcal{E}(W, r(1 - \lambda^k)^2)$ is a sequence of probabilistic reachable sets with violation probability n/r . If, moreover, w_k is a Gaussian process with null mean, then $\mathcal{E}(W, r(1 - \lambda^k)^2)$ is a reachable set with violation probability $1 - \chi_n^2(r)$.

Notice that, for every $\lambda \in [\rho(A), 1)$, the convex conditions (4.32) and (4.33) admit solutions and, for any matrix W satisfying them, the sets $\mathcal{E}(W, r(1 - \lambda^k)^2)$ form a sequence of probabilistic reachable sets with violation probability n/r or $(1 - \chi_n^2(r))$, in the Gaussian process case. Thus, condition (4.32) and (4.33) can be used in a convex optimization problem aiming at maximizing or minimizing a measure of the reachable sets, their volume for instance.

4.2.2.2 Probabilistic invariant sets

The concept of probabilistic invariant sets, as defined in [Kofman et al., 2012, Hewing et al., 2018], is recalled.

Definition 4.2.3 (Probabilistic invariant set) *The set $\Omega \subseteq \mathbb{R}^n$ is a probabilistic invariant set for the system (4.19), with violation level $\varepsilon \in [0, 1]$, if $x_0 \in \Omega$ implies $\Pr\{x_k \in \Omega\} \geq 1 - \varepsilon$ for all $k \geq 1$.*

A first condition for a set to be probabilistic invariant, analogous to that used for uncorrelated disturbances in [Hewing et al., 2018], is given.

Property 4.2.3 *Suppose that the random sequence $\{w_k\}_{k \in \mathbb{N}}$ has a correlation bound $\Gamma_w \succ 0$ for matrix A . If $W \in \mathcal{S}^n$ and $r > 0$ are such that $W \succ 0$ and*

$$A\mathcal{E}(W, 1) + \mathcal{E}(\Gamma_w, r) \subseteq \mathcal{E}(W, 1), \quad (4.34)$$

then $\mathcal{E}(W, 1)$ is a probabilistic invariant set with violation probability n/r . If, moreover, w_k is a Gaussian process with null mean, then $\mathcal{E}(W, 1)$ is a probabilistic invariant set with violation probability $1 - \chi_n^2(r)$.

Property 4.2.3 implies that the existence of a correlation bound provides a condition for probabilistic invariance that has the same structure as the one corresponding to robust invariance. In the case of ellipsoidal invariant sets, (4.34) results in a bilinear condition, see [Boyd et al., 1994], that can be solved, for instance, by gridding the space of the Lagrange multiplier and solving an LMI for every value as illustrated below. Nevertheless, as shown afterward, gridding can be avoided by choosing the multiplier in $[\rho(A), 1)$.

Proposition 4.2.5 *Suppose that the random sequence $\{w_k\}_{k \in \mathbb{Z}}$ has a correlation bound $\Gamma_w \succ 0$ for matrix A . If $W \in \mathcal{S}^n$ is such that $W \succ 0$ and*

$$\begin{bmatrix} A^\top W^{-1} A - \tau W^{-1} & A^\top W^{-1} \\ W^{-1} A & W^{-1} - (1 - \tau)\Gamma_w^{-1}/r \end{bmatrix} \preceq 0 \quad (4.35)$$

with $\tau \in [0, 1)$, then $\mathcal{E}(W, 1)$ is a probabilistic invariant set with violation probability n/r . If, moreover, w_k is a Gaussian process with null mean, then $\mathcal{E}(W, 1)$ is a probabilistic invariant set with violation probability $1 - \chi_n^2(r)$.

Although (4.35) is a non-convex condition, that can be solved with respect to W^{-1} by gridding τ in $[0, 1)$, this can be avoided by choosing $\tau \in [\rho(A), 1)$, as proved below.

Property 4.2.4 *Suppose that the random sequence $\{w_k\}_{k \in \mathbb{N}}$ has a correlation bound $\Gamma_w \succ 0$ for matrix A . Condition (4.35) admits a solution W for every $\tau \in [\rho(A), 1)$.*

From Property 4 it follows that for every $\tau \in [\rho(A), 1)$, the set of matrices W satisfying condition (4.35), convex in W^{-1} , is non-empty. Moreover, any W in this set provides the probabilistic invariant set $\mathcal{E}(W, 1)$ with violation level n/r or $1 - \chi_n^2(r)$, in the Gaussian process case. The constraint $\tau \in [\rho(A), 1)$ restricts, though, the set of feasible solutions and then, if one aims at obtaining the minimal probabilistic invariant ellipsoids, gridding τ in $[0, 1)$ might be necessary.

4.2.3 Numerical examples

Consider the system (4.19) with

$$A = \begin{bmatrix} 0.25 & 0 \\ 0.1 & 0.3 \end{bmatrix}.$$

To validate the presented results, it is necessary to generate a random sequence satisfying the bounds (4.22) and (4.23). In particular, an example is given for which the value of the covariance matrices cannot be computed, but bounds of the type (4.22) and (4.23) can be determined.

Consider the i.i.d. random sequence v_k with Gaussian distribution $\mathcal{N}(0, V)$, for all $k \in \mathbb{N}$, and the switched system with $m \in \mathbb{N}$ modes

$$w_{k+1} = H_{\sigma_k} w_k + F v_k \quad (4.36)$$

where $\sigma : \mathbb{N} \rightarrow \mathbb{N}_m$ is the mode selection signal, assumed arbitrary. Note that $\{w_k\}_{k \in \mathbb{N}}$ is a Gaussian process, since every linear combination of its terms has Gaussian distribution, being a linear combination of elements of v_k , that are i.i.d. with Gaussian distribution. Moreover $\{w_k\}_{k \in \mathbb{N}}$ has null mean since v_k has null mean.

Denote with w_k the state given by (4.36) with $w_0 = 0$ and switching sequence σ (the dependence of w_k on σ is left implicit); with $\sigma_{[i,j]}$ the subsequence of modes given by the realization of σ from instants i and j with $i < j$, and define $\mathcal{H}_{\sigma_{[i,j]}} = \prod_{k=i}^j H_{\sigma_k}$. Suppose there exist $\Gamma \succ 0$ and $\gamma \in [0, 1)$ such that

$$H_i \Gamma H_i^\top + F V F^\top \preceq \Gamma, \quad \forall i \in \mathbb{N}_m, \quad (4.37)$$

$$H_i \Gamma H_i^\top \preceq \gamma \Gamma, \quad \forall i \in \mathbb{N}_m. \quad (4.38)$$

It can be recursively proved that $E\{w_k w_k^\top\} \preceq \Gamma$. In fact, the condition holds for $k = 0$, from $w_0 = 0$. Suppose that $E\{w_k w_k^\top\} \preceq \Gamma$ holds for a given $k \in \mathbb{N}$ and since $E\{v_k v_k^\top\} = 0$, then

$$\begin{aligned} E\{w_{k+1} w_{k+1}^\top\} &= E\{H_{\sigma_k} w_k w_k^\top H_{\sigma_k}^\top + F v_k v_k^\top F^\top + H_{\sigma_k} w_k v_k^\top F^\top + F v_k w_k^\top H_{\sigma_k}^\top\} \\ &= H_{\sigma_k} E\{w_k w_k^\top\} H_{\sigma_k}^\top + F E\{v_k v_k^\top\} F^\top \preceq H_{\sigma_k} \Gamma H_{\sigma_k}^\top + F V F^\top \stackrel{(4.37)}{\preceq} \Gamma, \end{aligned}$$

for every $\sigma_k \in \mathbb{N}_m$, which means that $E\{w_{k+1} w_{k+1}^\top\} \preceq \Gamma$. For every $i, j \in \mathbb{N}$ with $i \neq j$, define $\Gamma_{i,j}^{(\sigma)} = E\{w_i w_j^\top\}$ and note that

$$\Gamma_{k+1,k}^{(\sigma)} = E\{w_{k+1} w_k^\top\} = E\{(H_{\sigma_k} w_k + F v_k) w_k^\top\} = E\{H_{\sigma_k} w_k w_k^\top\} + E\{F v_k w_k^\top\} = H_{\sigma_k} E\{w_k w_k^\top\}$$

for all $k \in \mathbb{N}$, and then, from $E\{w_k w_k^\top\} \preceq \Gamma$, it follows

$$\Gamma_{k+1,k}^{(\sigma)} \Gamma^{-1} \Gamma_{k+1,k}^{(\sigma)\top} = H_{\sigma_k} E\{w_k w_k^\top\} \Gamma^{-1} E\{w_k w_k^\top\} H_{\sigma_k}^\top \preceq H_{\sigma_k} E\{w_k w_k^\top\} H_{\sigma_k}^\top \preceq H_{\sigma_k} \Gamma H_{\sigma_k}^\top \stackrel{(4.38)}{\preceq} \gamma \Gamma$$

for every $\sigma_k \in \mathbb{N}_m$. Hence

$$\Gamma_{k+1,k}^{(\sigma_k)} \Gamma^{-1} \Gamma_{k+1,k}^{(\sigma_k)\top} \preceq \gamma \Gamma, \quad \forall \sigma_k \in \mathbb{N}_m.$$

Following analogous considerations it can be proved that

$$\Gamma_{j,i}^{(\sigma)} \Gamma^{-1} \Gamma_{j,i}^{(\sigma)\top} \preceq \mathcal{H}_{\sigma_{[i,j]}} \Gamma \mathcal{H}_{\sigma_{[i,j]}}^\top \preceq \gamma^{j-i} \Gamma, \quad \forall \sigma_{[i,j]} \in \mathbb{N}_m^{j-i}$$

for all $i, j \in \mathbb{N}$ such that $i < j$. Thus conditions (4.22) and (4.23) hold with $\tilde{\Gamma} = \Gamma$ and γ solution of (4.37)-(4.38), $\Gamma_{j,i} = \Gamma_{j,i}^{(\sigma)}$, $\alpha = 0$ and $\beta = 1$. Note that these bounds hold for every possible realization of the switching sequence σ_k .

An i.i.d. random sequence with distribution $\mathcal{N}(0, V)$, with $V = \text{diag}(1.5, 0.26)$, has been used to feed system (4.36) with

$$H_1 = \begin{bmatrix} 0.17 & 0.02 \\ 0.07 & 0.14 \end{bmatrix}, \quad H_2 = \begin{bmatrix} 0.15 & 0.025 \\ 0.1 & -0.25 \end{bmatrix}, \quad F = \begin{bmatrix} 0.25 & 0.025 \\ 0.1 & -0.35 \end{bmatrix}$$

and σ_k unknown function of time with value in $\{1, 2\}$. The switched system generates a Gaussian process w_k with null mean satisfying the covariance matrix bounds (4.22) and (4.23) and the correlation bound (4.25), with

$$\tilde{\Gamma} = \begin{bmatrix} 0.0098 & 0.0018 \\ 0.0018 & 0.0343 \end{bmatrix}, \quad \Gamma_w = \begin{bmatrix} 0.0113 & 0.0020 \\ 0.0020 & 0.0397 \end{bmatrix}$$

$\alpha = 0$, $\beta = 1$ and $\gamma = 0.0395$, and Γ_w computed using (4.28).

Different values of violation probability p_v have been tested, in particular $p_v = 0.1, 0.2, 0.3, 0.4, 0.5$. For every p_v , the values of r such that $\chi_2^2(r) = 1 - p_v$ has been determined and the matrix W solving (4.35) with minimal trace has been computed to obtain $\mathcal{E}(W, 1)$ probabilistic invariant. Then, for every p_v , $N = 1000$ initial states x_0 have been uniformly generated on the boundary of $\mathcal{E}(W, 1)$ and assumed independent on w_k . For each x_0 , a sequence w_k has been generated through (4.36) and applied. For every $k = 1, \dots, 100$, the set of states x_k and the number of violation d_k of the constraint $x_k \in \mathcal{E}(W, 1)$ have been computed. The frequencies of violation d_k/N , for every p_v and $k = 1, \dots, 100$, are depicted in Fig. 4.5, that shows that the bound is always satisfied.

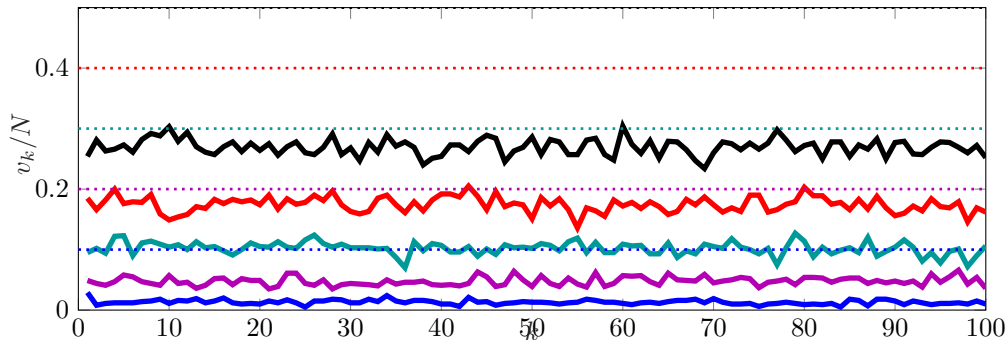

Figure 4.5: Frequency of violations d_k/N of $x_k \in \mathcal{E}(W, 1)$ for $k = 1, \dots, 100$, with $\alpha = 0$ and $\beta = 1$, obtained for violation probability of: 50% in black; 40% in red; 30% in cyan; 20% in magenta; 10% in blue.

4.3 Conclusions

In this chapter some results are recalled concerning my research on invariant set computation for high dimensional and stochastic linear systems. Invariance conditions for high dimensional systems are given in form of LP optimization problems, instead of using Minkowski sum of polyhedra, leading to convex conditions that do not require nonconvex problems solution as those related to Minkowski set addition and projection. Therefore, the results can be applied also for high dimensional systems, as illustrated by numerical examples of dimension bigger than 40. The results precision, moreover, is shown by a 30 dimensional linear system, for which the exact maximal control invariant set can be inferred and compared with the one obtained by employing the convex condition-based approach proposed.

In the second part of the chapter, the characterization and computation of reachability and invariance for stochastic linear systems is addressed. Methods are presented, based on convex optimization, to compute probabilistic reachable and invariant sets for linear systems fed by a stochastic disturbance correlated in time and partially unknown. From the knowledge of bounds on the mean and the covariance matrices, the characterization of the correlation bound is given and then employed for obtaining the reachable and invariant sets.

Stabilizability of switched systems

Contents

5.1	Stabilizability of switched systems	52
5.2	Necessary and sufficient condition	54
5.2.1	Duality robustness-control of switched systems	55
5.2.2	Switching control law	56
5.3	Sufficient conditions and comparisons	60
5.3.1	Lyapunov-Metzler BMI conditions	60
5.3.2	LMI sufficient condition	63
5.3.3	Stabilizability conditions relations	65
5.4	Computation-oriented condition	69
5.4.1	Conic partition and nonnegative quadratic forms	70
5.4.2	Local contraction constraint and algorithm	72
5.5	Control co-design	75
5.5.1	Switching law and feedback control co-design	75
5.5.2	Comparisons	78
5.6	Conclusions	80

Switched systems are characterized by a finite set of possible dynamics, among which the system evolves [Liberzon, 2003, Sun and Ge, 2011]. In the last decades, this class of systems attracted an increasing attention since it allows to model complex dynamics such as networked and interconnected systems and the interaction between physical systems and digital devices. Classical issues in automatic control, such as stability analysis and control design, result to be rather involved even for switched linear systems, though, yielding to the necessity of a tailored theory [Lin and Antsaklis, 2009, Sun and Ge, 2011].

The problem of stability or stabilizability, depending on the assumption on the switching law, of linear switched system attracted many research efforts, see the overview [Lin and Antsaklis, 2009] and the monograph [Sun and Ge, 2011]. Conditions for stability, that is when the switching law is considered as an exogenous signal, have been proposed: for instance, the joint spectral radius approach [Jungers, 2009a]; the polyhedral Lyapunov functions [Molchanov and Pyatnitskiy, 1989, Blanchini, 1995] and the path-dependent switched Lyapunov ones [Lee and Dullerud, 2007] or the variational approach [Margaliot, 2006] and [Daafouz et al., 2002] on mode-dependent Lyapunov functions.

Concerning the problem of stabilizability of switched linear systems, the necessity of using nonconvex or time-varying functions have been recognized, see [Blanchini and Savorgnan, 2008], and often employed to reduce the conservatism in constructive methods, for instance those based on Lyapunov-Metzler conditions [Geromel and Colaneri, 2006b, Geromel and Colaneri, 2006a], on

convex conditions [Sun and Ge, 2011, Fiacchini et al., 2016a], and on quadratic time-varying Lyapunov functions [Deaecto and Geromel, 2018]. Also necessary and sufficient conditions for stabilizability appeared, [Sun and Ge, 2011, Fiacchini and Jungers, 2014], highlighting the inherent complexity of the problem of determining whether a switched linear systems is stabilizable. As a matter of fact, testing whether a necessary and sufficient condition for stabilizability holds is equivalent to check if the unit ball is contained in the interior of the union of a potentially arbitrarily big number of ellipsoids, given by the ball preimages. The stabilizability problem has been proved, indeed, to be undecidable in [Jungers and Mason, 2017], that addresses the problem in terms of joint spectral subradius, see also [Jungers, 2009b].

A strictly weaker condition, referred to as uniform convergence [Stanford and Urbano, 1994], consistent [Sun, 2004, Sun and Ge, 2011] or periodic [Fiacchini et al., 2016a] stabilizability, has been also characterized and its relation with general stabilizability analysed. While the works [Stanford and Urbano, 1994, Sun, 2004, Sun and Ge, 2011] already proved that periodic stabilizability is only sufficient for stabilizability, [Fiacchini et al., 2016a] provides a necessary and sufficient convex condition for periodic stabilizability and its relation with Lyapunov-Metzler conditions. A hint on the conservatism of conditions for periodic stabilizability has been given in [Heemels et al., 2016b], expressing it in terms of S-procedure application. Thus, although necessary and sufficient conditions are available, their complexity led to inspect alternative conditions, just sufficient but more computationally affordable. The notable exception [Jungers and Mason, 2017] proposes algorithms to test necessary and sufficient conditions for stabilizability and to compute tight bounds on the convergence rate.

In this chapter, a summary of the main results on new necessary and sufficient conditions for stabilizability and sufficient ones for discrete-time switched linear systems is provided. First, the results on the geometric necessary and sufficient conditions are recalled together with the characterization of nonconvex, homogeneous functions as a universal class of Lyapunov functions for switched linear systems. The numerical aspects are highlighted and then addressed to provide alternative, only sufficient, conditions more computationally affordable. The relations between the different conditions are illustrated. Also the case of control co-design has been dealt with, based on the results on stabilizability. The contributions recalled here are the results of the collaboration with several researchers, namely **Marc Jungers** from CRAN, Nancy, **Antoine Girard** from LSS, Paris and **Sophie Tarbouriech** from LAAS, Toulouse. More details can be found in [Fiacchini et al., 2012b, Fiacchini and Jungers, 2013, Fiacchini and Jungers, 2014, Fiacchini et al., 2016b, Fiacchini et al., 2016a, Fiacchini and Tarbouriech, 2017] and also in [Fiacchini et al., 2018, Fiacchini, 2021].

5.1 Stabilizability of switched systems

Consider the discrete-time switched system

$$x_{k+1} = A_{\sigma(k)}x_k, \quad (5.1)$$

where $x_k \in \mathbb{R}^n$ is the state at time $k \in \mathbb{N}$ and $\sigma : \mathbb{N} \rightarrow \mathcal{I}$ (where $\mathcal{I} = \mathbb{N}_q$ is the set of q modes) is the switching law that, at any instant, selects the transition matrix among the finite set $\{A_i\}_{i \in \mathcal{I}}$, with $A_i \in \mathbb{R}^{n \times n}$ for all $i \in \mathcal{I}$. Given the initial state x_0 and a switching law $\sigma(\cdot)$, denote with $x_k^\sigma(x_0)$ the state of the system (5.1) at time k starting from x_0 by applying the switching law $\sigma(\cdot)$. In some cases σ can be a function of the state, for instance in the case of switching control law.

Assumption 5.1.1 *The matrices A_i , with $i \in \mathcal{I}$, are nonsingular.*

Assumption 5.1.1 is not restrictive. In fact, the stable eigenvalues of the matrices A_i are beneficial from the stability point of view of the switched systems and poles in zero are related to

the most contractive dynamics. Moreover, the results presented in the following can be extended to the general case with appropriate considerations.

Two main cases have to be discriminated depending on the assumptions on the switching law. If $\sigma(\cdot)$ is supposed to be an arbitrary function of time, that is acting as a perturbation, then the problem of asymptotic stability of the system under every possible switching law is usually considered. For this case necessary and sufficient conditions for stability exist. When $\sigma(\cdot)$ is considered as a manipulable signal, then the problem of asymptotic stabilizability (simply denoted as stabilizability in what follows) is addressed, that consists in the existence and the characterization of the switching laws that yield asymptotic stability if applied.

The system (5.1) is asymptotically stabilizable if there exists a switching law and a Lyapunov function for the resulting time-varying system. The switching law will belong to the class of state-dependent one, that is $\sigma(k) = g(x_k)$, where $g : \mathbb{R}^n \rightarrow \mathcal{I}$. Define, with a slight abuse of notation, the state-dependent switching law as $\sigma(k) = \sigma(x_k)$. More formally, the property of global exponential stabilizability for this context is defined below, and it will be simply referred to as stabilizability.

Definition 5.1.1 *The system (5.1) is globally exponentially stabilizable if there are $c \geq 0$ and $\lambda \in [0, 1)$ and, for all $x \in \mathbb{R}^n$, there exists a switching law $\sigma : \mathbb{N} \rightarrow \mathcal{I}$, such that*

$$\|x_k^\sigma(x)\| \leq c\lambda^k \|x\|, \quad \forall k \in \mathbb{N}. \quad (5.2)$$

A concept widely employed in the context of set-theory and invariance is the C-set, see [Blanchini, 1995, Blanchini and Miani, 2008]. A C-set is a compact, convex set with $0 \in \text{int}(\Omega)$. Define an analogous concept useful for the context considered here. For this, first recall that a set Ω is a star-convex set if there exists $x^0 \in \Omega$ such that every convex combination of x and x^0 belongs to Ω for every $x \in \Omega$.

Definition 5.1.2 *A set $\Omega \subseteq \mathbb{R}^n$ is a C^* -set if it is compact, star-convex with respect to the origin and $0 \in \text{int}(\Omega)$.*

Define the analogous of the gauge function of a C^* -set as

$$\Psi_\Omega(x) = \min_{\alpha \geq 0} \{\alpha \in \mathbb{R} : x \in \alpha\Omega\}, \quad (5.3)$$

for the C^* -set $\Omega \subseteq \mathbb{R}^n$. In what follows, it will be referred to $\Psi_\Omega(x)$ as the Minkowski function of Ω at x , with a slight abuse since it is usually defined for C-sets (or symmetric C-sets), [Rockafellar, 1970, Schneider, 1993, Blanchini and Miani, 2008]. Some properties of C^* -sets and their Minkowski functions are listed below.

Property 5.1.1 *Any C-set is a C^* -set. Given a C^* -set $\Omega \subseteq \mathbb{R}^n$, it holds that $\alpha\Omega \subseteq \Omega$ for all $\alpha \in [0, 1]$, and the Minkowski function $\Psi_\Omega(\cdot)$ is: homogeneous of degree one, i.e. $\Psi_\Omega(\alpha x) = \alpha\Psi_\Omega(x)$ for all $\alpha \geq 0$ and $x \in \mathbb{R}^n$; positive definite; defined on \mathbb{R}^n and radially unbounded.*

The Minkowski functions induced by C-sets have been used in literature as Lyapunov function candidates, see [Blanchini, 1994], and have been proved to be a universal class of Lyapunov functions for linear parametric uncertain systems, [Molchanov and Pyatnitskiy, 1989, Blanchini, 1995], and switched systems with arbitrary switching, [Lin and Antsaklis, 2009]. It is proved here that the Minkowski functions induced by C^* -sets form a universal class of Lyapunov function for switched systems with switching control law. For this, a definition of Lyapunov function is provided for the particular context, in analogy with the definition given in [Blanchini, 1995] for linear parametric uncertain systems.

Definition 5.1.3 *A positive definite continuous function $V : \mathbb{R}^n \rightarrow \mathbb{R}$ is a global Lyapunov function for the system (5.1) if there exist a positive $N \in \mathbb{N}$ and a switching law $\sigma(\cdot)$, defined on \mathbb{R}^n , such that V is non-increasing along the trajectories $x_k^\sigma(x)$ and decreasing after N steps, i.e. $V(x_1^\sigma(x)) \leq V(x)$ and $V(x_N^\sigma(x)) < V(x)$, for all $x \in \mathbb{R}^n$.*

The Definition 5.1.3 is a standard definition of global Lyapunov function (or, better, global control Lyapunov function) except for the N -steps decreasing requirement. On the other hand, such a function implies the convergence of every subsequence in $j \in \mathbb{N}$ of the trajectory, i.e. $x_{i+j}^\sigma(x)$ for all $i < N$, then also the convergence of the trajectory itself. This, with the stability assured by $V(x_1^\sigma(x)) \leq V(x)$, ensures global asymptotic stabilizability of the switched system.

Finally, given a Lyapunov function as defined in Definition 5.1.3, it is not complex to provide an analogous function that is monotonically decreasing, by exploiting the decreasing rate. An example is given in Proposition 5.3.3.

5.2 Necessary and sufficient condition

As recalled above, it is proved in [Molchanov and Pyatnitskiy, 1989] that for an autonomous linear switched system, the origin is asymptotically stable if and only if there exists a polyhedral Lyapunov function, see also [Blanchini, 1995, Lin and Antsaklis, 2009]. The main objective is to prove that analogous results can be stated in the case that the switching sequence is a properly chosen selection, that is considering it as a control law.

Recalling that $\Omega_i(\Omega) = \{x \in \mathbb{R}^n : A_i x \in \Omega\}$ for $i \in \mathcal{I}$, see Notation, consider the following algorithm:

Algorithm 2 Computation of a contractive C*-set for the system (5.1)

Initialization: given the C*-set $\Omega \subseteq \mathbb{R}^n$, define $\Omega^{(0)} = \Omega$ and $k = 0$;

Iteration for $k \geq 0$:

$$\Omega^{(k+1)} = \bigcup_{i \in \mathcal{I}} \Omega_i(\Omega^{(k)}); \quad (5.4)$$

Stop if $\Omega \subseteq \text{int}\left(\bigcup_{j \in \mathbb{N}_{k+1}} \Omega^{(j)}\right)$; denote $N = k + 1$ and

$$\bar{\Omega} = \bigcup_{j \in \mathbb{N}_N} \Omega^{(j)}. \quad (5.5)$$

From the geometrical point of view $\Omega^{(k+1)}$ are the $x \in \mathbb{R}^n$ for which there exists a selection $i(x) \in \mathcal{I}$ such that $A_{i(x)}x \in \Omega^{(k)}$. Thus, $\Omega^{(k)}$ is the set of x that can be driven in Ω in at most k steps and hence $\bar{\Omega}$ the set of those which can reach Ω in N or less steps, by an adequate switching law. It can be also easily proved that the sets $\Omega^{(k)}$ for all $k \geq 0$ are C*-sets.

Algorithm 2 provides a C*-set $\bar{\Omega}$ contractive in N steps, for every initial C*-set $\Omega \in \mathbb{R}^n$, if and only if the switched system (5.1) is stabilizable. Such a necessary and sufficient condition is stated in the theorem below.

Theorem 5.2.1 *There exists a Lyapunov function for the switched system (5.1) if and only if Algorithm 2 ends with finite N .*

The Algorithm 2 terminates after a finite number of iterations only if the switched system is stabilizable, then there is no guarantee of finite termination in general (which means it is a semi-algorithm, to be exact). Moreover, a sufficient condition for non-stabilizability is provided below and could be used to exclude the existence of a Lyapunov function and then to terminate the (semi-)algorithm.

The finite termination of Algorithm 2 is, then, a necessary and sufficient condition for the global asymptotic stabilizability of the switched system (5.1). An alternative formulation of such a necessary and sufficient condition is presented below.

Theorem 5.2.2 *There exists a Lyapunov function for the switched system (5.1) if and only if there exists a C^* -set whose Minkowski function is a Lyapunov function for the system or, analogously, if and only if for every C^* -set Ω there exists $N \in \mathbb{N}$ such that*

$$\Omega \subseteq \text{int} \left(\bigcup_{i \in \mathcal{I}^{[1:N]}} \Omega_i(\Omega) \right). \quad (5.6)$$

Theorem 5.2.2 states that the existence of a Lyapunov function induced by a C^* -set is a necessary and sufficient condition for stabilizability of switched systems. Hence, such functions, nonconvex and homogeneous of degree one, form a class of universal Lyapunov functions for the switched systems. This result is in line with the fact that the existence of convex Lyapunov functions is sufficient but not necessary for the stabilizability of a switched system, as proved in [Blanchini and Savorgnan, 2008].

To have a geometrical meaning of (5.6), recall that Ω_i is the preimage of Ω through \mathbb{A}_i , that is the set of states which reach Ω by applying the switching sequence $i \in \mathcal{I}^{[1:N]}$. Thus, the switched system (5.1) is stabilizable if and only if the union of all the preimages of Ω related to sequences of length smaller than or equal to N covers Ω , with N finite. This means that after N steps at most, all the points in the union of preimages are driven in Ω by an appropriate switching sequence.

Since the stabilizability property is not dependent on the choice of the initial C^* -set Ω , focusing on the case $\Omega = \mathcal{B}^n$ and ellipsoidal pre-images entails no loss of generality. Then condition (5.6) can be replaced by

$$\mathcal{B}^n \subseteq \text{int} \left(\bigcup_{i \in \mathcal{I}^{[1:N]}} \mathcal{B}_i^n \right), \quad (5.7)$$

for what concerns stabilizability, although the value N might depend on the choice of Ω . The fact that condition (5.7) represents a necessary and sufficient condition for stabilizability was first proved in [Sun and Ge, 2011].

The set inclusions (5.6) or (5.7) are the stopping conditions of the algorithm and then must be numerically checked at every step. The main computational issue is that determining if a C^* -set Ω is included into the interior of the union of some C^* -sets is very complex in general, also in the case of ellipsoidal sets where it relates to quantifier elimination over real closed fields [Bochnak et al., 1998]. On the other hand, the condition given by Theorem 5.2.2 provides an exact characterization of the complexity inherent to the problem of stabilizing a switched linear system.

Finally, it is worth to recall here that analogous results are given in [Fiacchini and Jungers, 2014] concerning a sufficient condition for non-stabilizability. Indeed, the existence of a C^* -set $\Omega \subseteq \mathbb{R}^n$ such that

$$\bigcup_{i \in \mathcal{I}} \Omega_i(\Omega) \subseteq \Omega \quad (5.8)$$

implies that there is not a stabilizing switching sequence. An algorithm is also provided in the cited paper whose finite termination is related to the existence of such a set and then to the non-stabilizability of the switched linear system.

5.2.1 Duality robustness-control of switched systems

Results from the literature on the stability of a switched linear system with arbitrary switching law $\sigma(\cdot)$ are recalled here to highlight the evident analogies with the approach results concerning stabilizability properties.

Consider the linear switched system (5.1) and assume that the switching law is arbitrary. This would mean that the switching law might be regarded as a parametric uncertainty and the results in [Molchanov and Pyatnitskiy, 1989, Blanchini, 1994, Blanchini, 1995] on robust stability apply with minor adaptations, see also [Lin and Antsaklis, 2009]. The following algorithm provides a polytopic contractive set, and then an induced polyhedral Lyapunov function, for this class of systems, see [Blanchini and Miani, 2008].

Algorithm 3 Computation of a λ -contractive C-set for (5.1) with arbitrary switching law

Initialization: given the C-set $\Gamma \subseteq \mathbb{R}^n$ and $\lambda \in [0, 1)$, define $\Gamma^{(0)} = \Gamma$ and $k = 0$;

Iteration for $k \geq 0$:

$$\Gamma^{(k+1)} = \Gamma \cap \bigcap_{i \in \mathbb{N}_q} \lambda A_i^{-1} \Gamma^{(k)}; \quad (5.9)$$

Stop if $\Gamma_k \subseteq \Gamma_{k+1}$; denote $N = k$ and $\bar{\Gamma} = \Gamma^{(k)}$.

The set $\bar{\Gamma}$ is the maximal λ -contractive set in Γ for the switched system with arbitrary switching law. Provided the Algorithm 3 terminates with finite N , it can be proved that the system is globally exponentially stable, see [Blanchini, 1995].

Notice the analogies between the Algorithms 2 and 3: they share the same iterative structure and they both generate contractive sets which induce Lyapunov functions provided they terminate in a finite number of steps. The main substantial difference consists in the use of intersection/union operators and in the family of sets generated, C^* -sets by Algorithm 2 and C-sets by Algorithm 3. Interestingly enough, the C-sets are closed under the intersection operation whereas C^* -sets are closed under the union. The C^* -sets have for switched systems with switching control law the role that C-sets have for the case of arbitrary switching law.

Recall finally that, for linear parametric uncertain systems, the existence of a polyhedral Lyapunov function is a necessary and sufficient condition for asymptotic stability.

Theorem 5.2.3 ([Molchanov and Pyatnitskiy, 1989, Blanchini, 1995]) *There exists a Lyapunov function for a linear parametric uncertain system if and only if there exists a polyhedral Lyapunov function for the system.*

The result in Theorem 5.2.3 holds for general parametric uncertainty and applies also for switched systems with arbitrary switching law, as remarked in [Lin and Antsaklis, 2009]. As for the duality of the Algorithms 2 and 3 highlighted above, evident conceptual analogies hold between Theorem 5.2.2 and Theorem 5.2.3. Then the class of Lyapunov functions induced by C^* -sets is universal for linear switched systems with switching control law, in analogy with the class of polyhedral functions (i.e. induced by C-sets) for the case of arbitrary switching law, [Blanchini, 1994, Blanchini, 1995].

5.2.2 Switching control law

Besides a Lyapunov function, Algorithm 2 provides a stabilizing switching control law or, better, a family of stabilizing control laws for system (5.1), if it terminates in finite time.

Proposition 5.2.1 *If Algorithm 2 ends with finite N then $\Psi_{\bar{\Omega}} : \mathbb{R}^n \rightarrow \mathbb{R}$ is a Lyapunov function for the switched system (5.1) and given the set valued map*

$$\bar{\Sigma}(x) = \arg \min_{(i,k)} \{ \Psi_{\Omega_i^{(k)}}(x) : i \in \mathbb{N}_q, k \in \mathbb{N}_N \} \subseteq \mathbb{N}_q \times \mathbb{N}_N, \quad (5.10)$$

where $\Omega_i^{(k)} = \Omega_i(\Omega^{(k-1)})$, any switching law defined as

$$(\bar{\sigma}(x), \bar{k}(x)) \in \bar{\Sigma}(x), \quad (5.11)$$

is a stabilizing switching law and such that

$$\begin{aligned} \Psi_{\bar{\Omega}}(x_{\bar{k}(x)}^{\bar{\sigma}}(x)) &\leq \bar{\lambda} \Psi_{\bar{\Omega}}(x), \\ \Psi_{\bar{\Omega}}(x_j^{\bar{\sigma}}(x)) &\leq \Psi_{\bar{\Omega}}(x), \quad \forall j \in \mathbb{N}_{\bar{k}(x)}, \end{aligned}$$

with $\bar{\lambda} = \bar{\lambda}(\Omega) = \min_{\lambda} \{\lambda \geq 0 : \Omega \subseteq \lambda \bar{\Omega}\}$.

To speed up the convergence of the trajectory of the system to origin, one could appropriately select among the elements of $\bar{\Sigma}(x)$, those whose k is minimal. Moreover, a consequence of Proposition 5.2.1 is that, if Algorithm 2 ends with finite N then the switching law defined by (5.10) and (5.11) is such that

$$\Psi_{\bar{\Omega}}(x_{pN}^{\bar{\sigma}}(x)) \leq \bar{\lambda}^p \Psi_{\bar{\Omega}}(x),$$

for every $p \in \mathbb{N}$ and all $x \in \mathbb{R}^n$.

As said above, if the system is asymptotically stabilizable, then the algorithm ends with finite N for all initial \mathbb{C}^* -set Ω . Clearly, the value of N and the complexity of the set $\bar{\Omega}$ depend on the choice of Ω . In particular, if Ω is the Euclidean norm ball (or the union of ellipsoids), the sets $\Omega_i^{(k)}$ and $\Omega^{(k)}$, with $i \in \mathbb{N}_q$ and $k \in \mathbb{N}_N$, are unions of ellipsoids, and so is $\bar{\Omega}$. Then, the switching law computation reduces to check the minimal value among $x^T P_j x$ with $j \in \bar{N}$, where $\{P_j\}_{j \in \bar{N}}$ are the \bar{N} positive definite matrices that define $\bar{\Omega}$, recalling that $\bar{N} = q + \dots + q^N$. Moreover, if Ω is a polytope (or a union of polytopes), also $\Omega_i^{(k)}$, Ω_k , with $i \in \mathbb{N}_q$ and $k \in \mathbb{N}_N$, and $\bar{\Omega}$ are so. In this case, the switching law is obtained by evaluating the linear inequalities defining those polytopes.

5.2.2.1 Example

Consider the system (5.1) with $q = 4$, $n = 2$ and

$$A_1 = \begin{bmatrix} 1.5 & 0 \\ 0 & -0.8 \end{bmatrix}, \quad A_2 = 1.1 R(\frac{2\pi}{5}), \quad A_3 = 1.05 R(\frac{2\pi}{5} - 1), \quad A_4 = \begin{bmatrix} -1.2 & 0 \\ 1 & 1.3 \end{bmatrix},$$

where $R(\theta)$ is the rotation matrix:

$$R(\theta) = \begin{bmatrix} \cos(\theta) & -\sin(\theta) \\ \sin(\theta) & \cos(\theta) \end{bmatrix}. \quad (5.12)$$

The matrices A_i , with $i \in \mathcal{I}$ with $\mathcal{I} = \mathbb{N}_4$, are not Schur, which implies that the system (5.1) is not stabilizable by any constant switching law. Algorithm 2 is applied with $\Omega = \mathcal{B}^2$. The sets $\Omega^{(k)}$, $k \in \mathbb{N}$ are thus unions of ellipsoids. The result at the first step is depicted in Figure 5.1. $\Omega^{(1)}$ is the union the four ellipsoids $A_j^{-1} \mathcal{B}^2$, with $j \in \mathbb{N}_4$. It is clear that \mathcal{B}^2 does not belong to $\Omega^{(1)}$. The next step of the algorithm leads to a set $\bigcup_{k \in \mathbb{N}_2} \Omega^{(k)}$ given by the union of the $4 + 4^2 = 20$ ellipsoids at most, i.e. $A_j^{-1} \mathcal{B}^2$ with $j \in \mathbb{N}_4$ and $A_j^{-1} A_i^{-1} \mathcal{B}^2$, for all $(i, j) \in \mathbb{N}_4 \times \mathbb{N}_4$. Since \mathcal{B}^2 does not belong to $\bigcup_{k \in \mathbb{N}_2} \Omega^{(k)}$, see Figure 5.1 (top right), the termination condition is not satisfied. The algorithm stops at the fifth iteration. Figure 5.1, bottom left, shows that \mathcal{B}^2 is included in $\bigcup_{k \in \mathbb{N}_5} \Omega^{(k)}$. A stabilizing switching law, satisfying (5.11) is given in Figure 5.1 for the initial condition $x_0 = (-3, 3)^T$. The Lyapunov function converges to zero, see Figure 5.1.

5.2.2.2 Example

There are undecidable cases for which neither the conditions for stabilizability nor the one for non-stabilizability are satisfied. Consider

$$A_1 = \begin{bmatrix} 1.3 & 0 \\ 0 & 0.9 \end{bmatrix} R(\theta), \quad A_2 = \begin{bmatrix} 1.4 & 0 \\ 0 & 0.8 \end{bmatrix}, \quad (5.13)$$

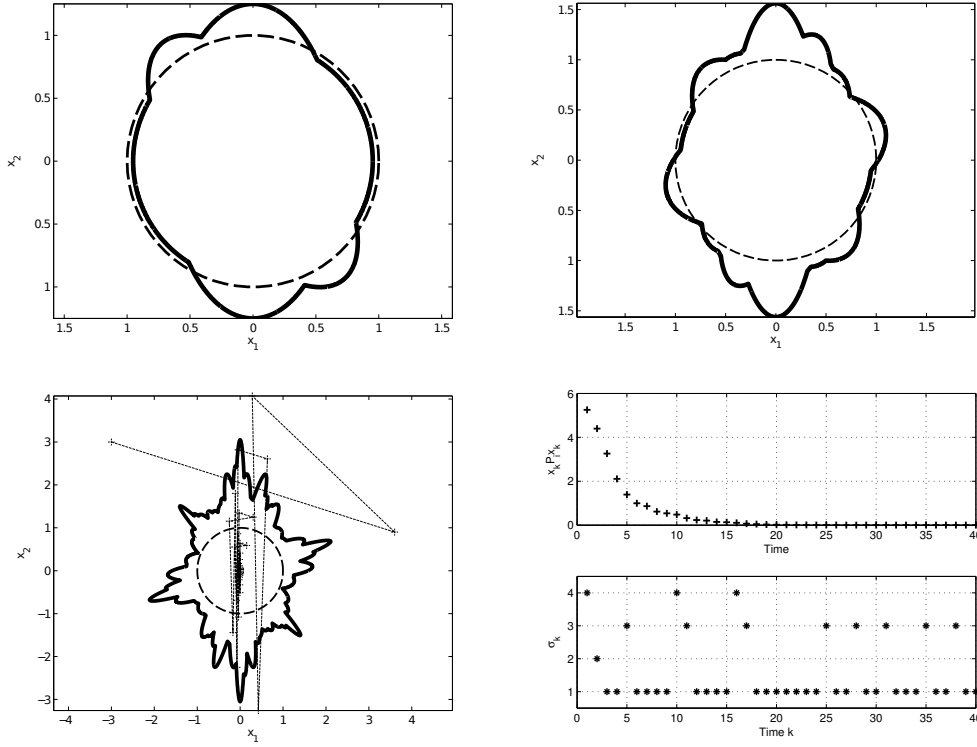

Figure 5.1: Top: Ball $\Omega = \mathcal{B}^2$ in dashed and $\Omega^{(1)}$ and $\bigcup_{k \in \mathbb{N}_2} \Omega^{(k)}$ solid line. Bottom left: ball $\Omega = \mathcal{B}^2$ in dashed and $\bigcup_{k \in \mathbb{N}_5} \Omega^{(k)}$ in solid line. Trajectory starting from $x_0 = (-3, 3)^T$ in dotted line. Right: Lyapunov function and switching control law in time.

with $R(\theta)$ as in (5.12) and $\theta = 0$ for the moment. Matrices A_1 and A_2 are not Schur. Four steps are applied for each algorithm. The results are drawn in Figure 5.2, left. Notice that $x = (1, 0)^T$ is related to an unstable eigenvalue for both modes, then Algorithm 2 cannot be finite. Moreover, since along the direction $x = (0, 1)^T$ the set $\bigcup_{k \in \mathbb{N}_i} \Omega^{(k)}$ is increasing with i , then the non-stabilizability condition (5.8) cannot hold either.

Consider now the system given by (5.13) with $\theta = \frac{\pi}{5}$, which means that the first mode performs now a rotation of $\frac{\pi}{5}$. Algorithm 2 stops after seven steps implying the stabilizability of the system. The result is given in Figure 5.2, right.

5.2.2.3 Example

An example, satisfying the condition for non-stabilizability (5.8), is proposed here. Consider

$$A_1 = 2 \begin{bmatrix} 0 & -1.01 \\ 1 & -1 \end{bmatrix}, \quad A_2 = 2 \begin{bmatrix} 0 & -1.01 \\ 1 & -0.5 \end{bmatrix}.$$

Condition (5.8) is satisfied, as shown in Figure 5.3, then the system is not stabilizable.

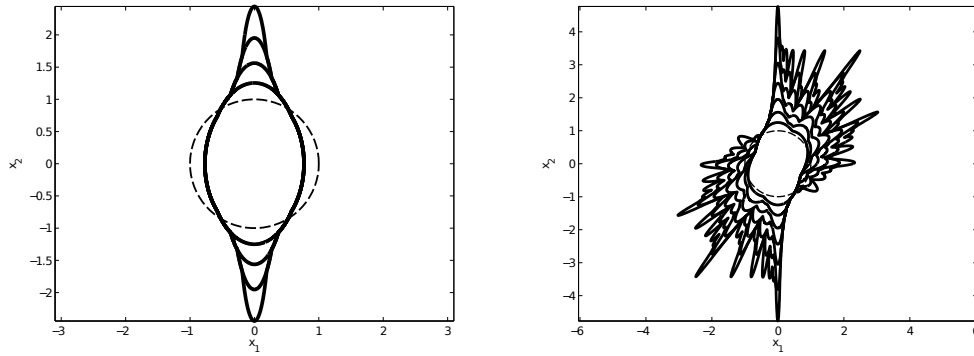

Figure 5.2: Ball $\Omega = \mathcal{B}^2$ in dashed and $\bigcup_{k \in \mathbb{N}_i} \Omega^{(k)}$ in solid line for $i \in \mathbb{N}_4$ with $\theta = 0$ on the left and for $i \in \mathbb{N}_7$ with $\theta = \pi/5$ on the right.

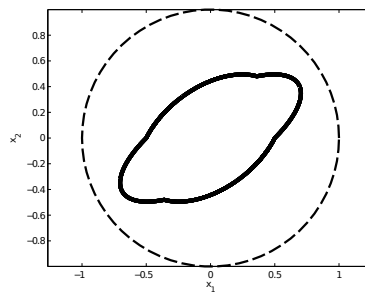

Figure 5.3: Ball \mathcal{B}^2 in dashed and $\bigcup_{k \in \mathbb{N}_1} \Omega_k$ in solid line.

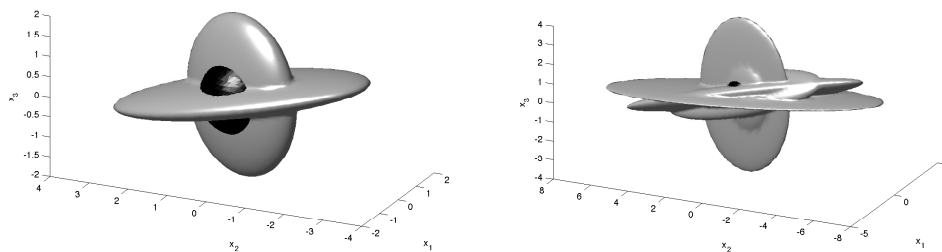

Figure 5.4: Ball $\Omega = \mathcal{B}^3$ in dark and $\bigcup_{k \in \mathbb{N}_j} \Omega^{(k)}$, for $j \in \mathbb{N}_2$, in light gray.

5.2.2.4 Example

Consider $q = 2$ and $n = 3$ with

$$A_1 = \begin{bmatrix} 1.2 & 0 & 0 \\ -1 & 0.8 & 0 \\ 0 & 0 & 0.5 \end{bmatrix}, \quad A_2 = \begin{bmatrix} 0.7 & 0 & 0 \\ 0 & -0.6 & -2 \\ 0 & 0 & -1.2 \end{bmatrix}.$$

A_1 and A_2 are not Schur. The ball \mathcal{B}^3 is chosen as initial set. Algorithm 2 ends at the third step. The Figures 5.4 and 5.5 depict the ball \mathcal{B}^3 and the sets $\bigcup_{k \in \mathbb{N}_j} \Omega^{(k)}$, with $j \in \mathbb{N}_3$.

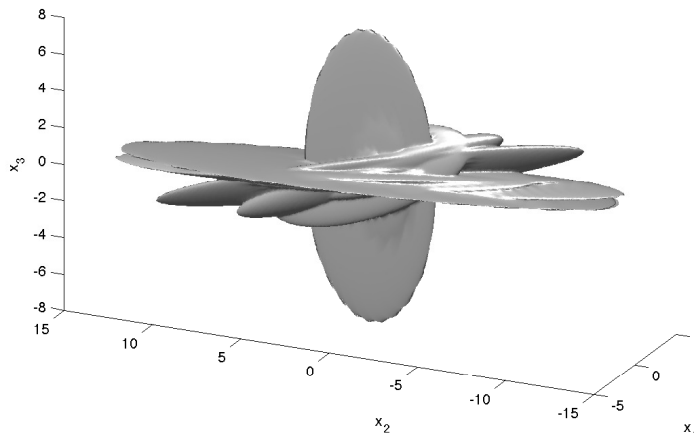

Figure 5.5: Set $\bigcup_{k \in \mathbb{N}_j} \Omega^{(k)}$, for $j = 3$, in light gray.

5.3 Sufficient conditions and comparisons

Necessary and sufficient conditions for stabilizability, in algorithmic and geometric forms, have been given in the previous section. Alternative conditions for stabilizability are also presented in the sequel to give geometrical and numerical insights and analyze their conservatism by comparison with the necessary and sufficient one given in Theorem 5.2.2.

5.3.1 Lyapunov-Metzler BMI conditions

Conditions for the stabilizability of switched system based on the Lyapunov-Metzler inequalities are among the less conservative. Such conditions are given by nonlinear matrix inequalities whose solution is often numerically intractable, though, see [Geromel and Colaneri, 2006b, Geromel and Colaneri, 2006a]. In the continuous-time context, it has been proved that the existence of a stable convex combination of the matrices A_i , with $i \in \mathcal{I}$, is a sufficient condition (and also necessary for $q = 2$) for the Lyapunov-Metzler inequalities to hold. Such a condition on the convex combinations of the modes is at the core of the stabilizing techniques in the literature, see [Liberzon, 2003].

For discrete-time systems, though, this relation is less evident. It is worth to consider the Lyapunov-Metzler condition to obtain an appropriate comparison, although its evaluation would

require a computationally demanding approach. It has to be recalled, nevertheless, that Lyapunov-Metzler conditions deal with nonconvex Lyapunov functions, namely homogeneous ones whose level sets are union of ellipsoids.

The first condition considered is related to the classical Lyapunov-Metzler inequality: it is sufficient and given by a set of BMI inequalities involving the Metzler matrices.

Theorem 5.3.1 ([Geromel and Colaneri, 2006b]) *If there exist $P_i \succ 0$, with $i \in \mathcal{I}$, and $\pi \in \mathcal{M}_q$ such that*

$$A_i^T \left(\sum_{j=1}^q \pi_{ji} P_j \right) A_i - P_i \prec 0, \quad \forall i \in \mathcal{I}, \quad (5.14)$$

holds, then the switched system (5.1) is stabilizable.

As proved in the paper [Geromel and Colaneri, 2006b], the satisfaction of condition (5.14) implies that the homogeneous function induced by the set $\bigcup_{i \in \mathcal{I}} \mathcal{E}(P_i)$ is a control Lyapunov function for the system. As proved in [Fiacchini et al., 2016a] the satisfaction of the Lyapunov-Metzler inequalities (5.14) implies that the necessary and sufficient condition given by Theorem 5.2.2 holds for the particular case of $\Omega = \bigcup_{i \in \mathcal{I}} A_i \mathcal{E}(P_i)$ and $N = 1$.

Theorem 5.3.2 *If the Lyapunov-Metzler condition (5.14) holds then (5.6) holds with $N = 1$ and $\Omega = \bigcup_{i \in \mathcal{I}} A_i \mathcal{E}(P_i)$.*

Theorem 5.3.2 provides a geometrical meaning of the Lyapunov-Metzler condition and a first relation with the necessary and sufficient condition for stabilizability given in Theorem 5.2.2.

5.3.1.1 Example

This example provides a hint on the conservatism of Lyapunov-Metzler condition with respect the general necessary and sufficient condition for stabilizability. Consider $q = n = 2$ and

$$A_1 = \begin{bmatrix} 0 & -1.01 \\ 1 & -1 \end{bmatrix}, \quad A_2 = \begin{bmatrix} 0 & -1.01 \\ 1 & -0.5 \end{bmatrix}.$$

The Lyapunov-Metzler approach results in a set of linear matrix inequalities once two parameters are fixed, both contained in $[0, 1]$, see [Geromel and Colaneri, 2006b]. The LMI conditions have been checked on a grid of these parameters, with step of 0.01. No admissible solution was found, whereas the Algorithm 2 stops at the third step. Figure 5.6 shows that $\mathcal{B}^2 = \Omega \subseteq \text{int}(\bigcup_{k \in \mathbb{N}_3} \Omega^{(k)})$. The Lyapunov function and the switching law are given in Figure 5.6 right. Notice that the Lyapunov function is not a decreasing function, but only a non-increasing one which is strictly decreasing at least once every three (the number of steps of the algorithm) instants, as expected.

5.3.1.2 Generalized Lyapunov-Metzler conditions

As the previous example proves, Lyapunov-Metzler condition is just sufficient for stabilizability, in general. Consider now a first direct generalization of the Lyapunov-Metzler condition, that can be obtained by removing the unnecessary link between the number of ellipsoids (and matrices P_i) and the system modes.

Proposition 5.3.1 *If there exist $M \in \mathbb{N}$ and $P_i \succ 0$, with $i \in \mathcal{I}^{[1:M]}$, and $\pi \in \mathcal{M}_{\bar{M}}$ such that*

$$\mathbb{A}_i^T \left(\sum_{j \in \mathcal{I}^{[1:M]}} \pi_{ji} P_j \right) \mathbb{A}_i - P_i \prec 0, \quad \forall i \in \mathcal{I}^{[1:M]}, \quad (5.15)$$

holds, then the switched system (5.1) is stabilizable.

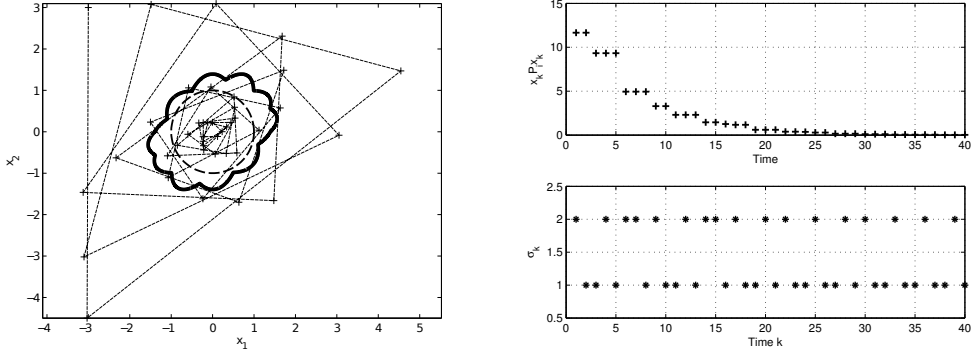

Figure 5.6: Left: ball $\Omega = \mathcal{B}^2$ in dashed and $\bigcup_{k \in \mathbb{N}_3} \Omega^{(k)}$ in solid line. Trajectory starting from $x_0 = (-3, 3)^T$ in dotted line. Right: Lyapunov function and switching control law in time.

Proposition 5.3.1 extends the Lyapunov-Metzler condition providing a more general one. Notice in fact that Theorem 5.3.1 is recovered for $M = 1$. An interesting issue is the relation with the necessary and sufficient condition for stabilizability, as well as with other ones.

The condition (5.15) can be interpreted in terms of the classical Lyapunov-Metzler condition (5.14) by considering the switched system obtained by defining one fictitious mode for every matrix A_i with $i \in \mathcal{I}^{[1:M]}$. Thus, testing the generalized Lyapunov-Metzler condition is equivalent to check the classical one for a system whose modes are related to every possible sequence of the original system (5.1), of length M or less.

Another possible extension of the classical Lyapunov-Metzler condition consists in maintaining the sequence length in 1 but increase the number of ellipsoids involved.

Proposition 5.3.2 *If for every $i \in \mathcal{I}$ there exist a set of indices $\mathcal{K}_i = \mathbb{N}_{h_i}$, with $h_i \in \mathbb{N}$; a set of matrices $P_k^{(i)} \succ 0$, with $k \in \mathcal{K}_i$, and there are $\pi_{m,k}^{(p,i)} \in [0, 1]$, satisfying*

$$\sum_{p \in \mathcal{I}} \sum_{m \in \mathcal{K}_p} \pi_{m,k}^{(p,i)} = 1, \quad (5.16)$$

for all $k \in \mathcal{K}_i$, such that

$$A_i^T \left(\sum_{p \in \mathcal{I}} \sum_{m \in \mathcal{K}_p} \pi_{m,k}^{(p,i)} P_m^{(p)} \right) A_i - P_k^{(i)} \prec 0, \quad \forall i \in \mathcal{I} \forall k \in \mathcal{K}_i, \quad (5.17)$$

holds, then the switched system (5.1) is stabilizable.

Geometrically, Proposition 5.3.2 provides a condition under which there exists a C^* -set composed by a finite number of ellipsoids that is contractive. Namely, the condition is sufficient for the existence of a set of ellipsoids, determined by $P_k^{(i)}$ with $k \in \mathcal{K}_i$, associated to every mode i , whose image through A_i is mapped inside the C^* -set. Thus, the induced homogeneous function is a control Lyapunov function. Notice that the classical Lyapunov-Metzler condition, i.e. Theorem 5.3.1, is a particular case of Proposition 5.3.2, with the restriction $h_i = 1$ for all $i \in \mathcal{I}$.

5.3.2 LMI sufficient condition

The main drawback of the necessary and sufficient set-inclusion condition for stabilizability is, as already stated, its inherent complexity. On the other hand, the Lyapunov-Metzler-based approach leads to a more practical BMI sufficient condition. Nevertheless, the complexity could be still computationally prohibitive, see [VanAntwerp and Braatz, 2000]. An alternative condition, only sufficient though, that can be checked by convex optimization programs, is given hereafter.

Theorem 5.3.3 *The switched system (5.1) is stabilizable if there exist $N \in \mathbb{N}$ and $\eta \in \mathbb{R}^{\bar{N}}$ such that $\eta \geq 0$, $\sum_{i \in \mathcal{I}^{[1:N]}} \eta_i = 1$ and*

$$\sum_{i \in \mathcal{I}^{[1:N]}} \eta_i \mathbb{A}_i^T \mathbb{A}_i \prec I. \quad (5.18)$$

An interesting issue is whether the sufficient condition for stabilizability given in Theorem 5.3.3 is also necessary. One particular case in which the LMI condition is guaranteed to have a solution, provided the switched system (5.1) is stabilizable, follows.

Corollary 5.3.1 *If there exist $N \in \mathbb{N}$ and $i, j \in \mathcal{I}^{[1:N]}$ such that $\mathcal{B} \subseteq \text{int}(\mathcal{B}_i \cup \mathcal{B}_j)$ then there is $\eta \in [0, 1]$ such that*

$$\eta \mathbb{A}_i^T \mathbb{A}_i + (1 - \eta) \mathbb{A}_j^T \mathbb{A}_j \prec I.$$

The condition presented in Theorem 5.3.3 is just sufficient unless there exists, among the \mathcal{B}_i , two ellipsoids containing \mathcal{B} in their union, see Corollary 5.3.1. This is proved by the following counter-example.

5.3.2.1 Example

The aim of this illustrative example is to show a case for which the inclusion condition (5.7) is satisfied with $N = 1$, but there is not a finite value of $N \in \mathbb{N}$ for which condition (5.18) holds. Consider the three modes given by the matrices

$$A_1 = AR(0), \quad A_2 = AR\left(\frac{2\pi}{3}\right), \quad A_3 = AR\left(\frac{-2\pi}{3}\right), \quad \text{with } A = \begin{bmatrix} a & 0 \\ 0 & a^{-1} \end{bmatrix},$$

with $R(\theta)$ as in (5.12) and $a = 0.6$. Set $\Omega = \mathcal{B}^2$. By geometric inspection of Figure 5.7, condition (5.7) holds at the first step, i.e. for $N = 1$. On the other hand, A_i are such that $\det(A_i^T A_i) = a^2 a^{-2} = 1$ and $\text{tr}(A_i^T A_i) = a^2 + a^{-2} = 3.1378$ while for the identity matrix, defining \mathcal{B}^2 , the determinant and the trace are 1 and 2, respectively. Notice that $a^2 + a^{-2} > 2$ for every a different from 1 or -1 and $a^2 + a^{-2} = 2$ otherwise.

For every N and every Ω_i with $i \in \mathcal{I}^{[1:N]}$, the related \mathbb{A}_i is such that $\det(\mathbb{A}_i^T \mathbb{A}_i) = 1$ and $\text{tr}(\mathbb{A}_i^T \mathbb{A}_i) \geq 2$. Notice that, for all the matrices $Q \succ 0$ in $\mathbb{R}^{2 \times 2}$ such that $\det(Q) = 1$, then $\text{tr}(Q) \geq 2$ and $\text{tr}(Q) = 2$ if and only if $Q = I$, since the determinant is the product of the eigenvalues and the trace its sum. Thus, for every subset of the ellipsoids Ω_i , determined by a subset of indices $K \subseteq \mathcal{I}^{[1:N]}$, it follows that

$$\sum_{i \in K} \eta_i \mathbb{A}_i^T \mathbb{A}_i \prec I,$$

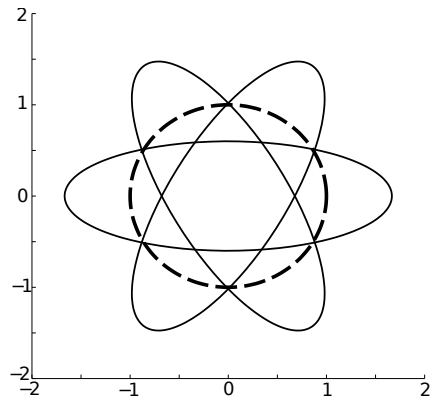

Figure 5.7: Sets $\Omega_1, \Omega_2, \Omega_3$ (solid) and $\Omega = \mathcal{B}^2$ (dashed).

cannot hold, since either $\text{tr}(\mathbb{A}_i^T \mathbb{A}_i) > 2$ or $\mathbb{A}_i^T \mathbb{A}_i = I$. Thus the LMI condition (5.18) is sufficient but not necessary.

The LMI condition (5.18) can be interpreted in terms of control Lyapunov functions and can be used to derive the controller synthesis techniques. Let us assume that (5.18) holds, then there exists $\mu \in [0, 1)$ such that

$$\sum_{i \in \mathcal{I}^{[1:N]}} \eta_i \mathbb{A}_i^T \mathbb{A}_i \leq \mu^2 I. \quad (5.19)$$

Also, for all $x \in \mathbb{R}^n$, it holds

$$\min_{i \in \mathcal{I}^{[1:N]}} (x^T \mathbb{A}_i^T \mathbb{A}_i x) \leq \mu^2 x^T x. \quad (5.20)$$

A stabilizing control strategy can be directly determined. The controller does not necessarily select at each time step $k \in \mathbb{N}$ which input should be applied. This is done only at given instant $\{k_p\}_{p \in \mathbb{N}}$ with $k_0 = 0$, and $k_p < k_{p+1} \leq k_p + N$, for all $p \in \mathbb{N}$. At time k_p , the controller selects the sequence of inputs to be applied up to step $k_{p+1} - 1$. The instant k_{p+1} is also determined by the controller at time k_p . More precisely, the controller acts as follows for all $p \in \mathbb{N}$, let

$$i_p = \arg \min_{i \in \mathcal{I}^{[1:N]}} (x_{k_p}^T \mathbb{A}_i^T \mathbb{A}_i x_{k_p}). \quad (5.21)$$

Then, the next instant k_{p+1} is given by

$$k_{p+1} = k_p + l(i_p), \quad (5.22)$$

with $l(i_p)$ length of i_p , and the controller applies the sequence of inputs

$$\sigma_{k_p+j-1} = i_{p,j}, \quad \forall j \in \{1, \dots, l(i_p)\}. \quad (5.23)$$

Theorem 5.3.4 *Assume that (5.18) holds, and consider the control strategy given by (5.21), (5.22), (5.23). Then, for all $x_0 \in \mathbb{R}^n$, for all $k \in \mathbb{N}$,*

$$\|x_k\| \leq \mu^{k/N-1} L^{N-1} \|x_0\| \quad (5.24)$$

holds, with $L \geq \|A_i\|$, for all $i \in \mathcal{I}$ and, hence, the controlled switched system is globally exponentially stable.

From Theorem 5.3.4, the LMI condition (5.18) implies that the switched system with the switching rule given by (5.21), (5.22), (5.23) is globally exponentially stable. Nevertheless, neither the Euclidean norm of x nor the function $\min_{i \in \mathcal{I}^{[1:N]}} (x^T \mathbb{A}_i^T \mathbb{A}_i x)$ are monotonically decreasing along the trajectories. On the other hand a positive definite homogeneous nonconvex function decreasing at every step can be inferred for a different switching rule.

Proposition 5.3.3 *Given the switched system (5.1), suppose there exist $N \in \mathbb{N}$ and $\eta \in \mathbb{R}^{\bar{N}}$ such that $\eta \geq 0$, $\sum_{i \in \mathcal{I}^{[1:N]}} \eta_i = 1$ and (5.18) hold. Then there is $\lambda \in [0, 1)$ such that the function*

$$V(x) = \min_{i \in \mathcal{I}^{[1:N]}} (x^T \lambda^{-n_i} \mathbb{A}_i^T \mathbb{A}_i x), \quad (5.25)$$

where n_i is the length of $i \in \mathcal{I}^{[1:N]}$, satisfies $V(A_{\sigma(x)} x) \leq \lambda V(x)$ for all $x \in \mathbb{R}^n$, with

$$i^*(x) = \arg \min_{i \in \mathcal{I}^{[1:N]}} (x^T \lambda^{-n_i} \mathbb{A}_i^T \mathbb{A}_i x), \quad (5.26)$$

and $\sigma(x) = i_1^(x)$.*

If the LMI (5.18) has a solution, then there exists a scalar $\mu \in [0, 1)$, such that (5.19) is verified. The value of μ induces straightforwardly the rate of convergence λ for the Lyapunov function (5.25). Thus one might solve the optimization problem $\min_{\mu^2, \eta} \mu^2$ subject to (5.19), to get higher convergence rate.

Notice that, although $V(x)$ defined in (5.25) is not homogeneous of order one, its square root is so, as for the set-induced Lyapunov functions given in [Fiacchini and Jungers, 2014].

5.3.2.2 LMI-condition and periodic stabilizability

Another interesting implication that follows from the Example 5.3.2.1 concerns the stabilizability through periodic switching sequences, introduced here.

A periodic switching law is given by $\sigma(k) = i_{p(k)}$ and

$$p(k) = k - M \lfloor k/M \rfloor + 1,$$

with $M \in \mathbb{N}$ and $i \in \mathcal{I}^M$, which means that the sequence of modes given by i repeats cyclically in time. One issue treated here concerns the stabilizability through periodic switching law, i.e. conditions under which system (5.1) is stabilized by means of a periodic $\sigma(\cdot)$. This property, formalized below, will be referred to as periodic stabilizability.

Definition 5.3.1 *The system (5.1) is periodic stabilizable if there exist a periodic switching law $\sigma : \mathbb{N} \rightarrow \mathcal{I}$, $c \geq 0$ and $\lambda \in [0, 1)$ such that (5.2) holds for all $x \in \mathbb{R}^n$.*

Notice that for stabilizability the switching function might be state-dependent, hence a state feedback, whereas for having periodic stabilizability the switching law must be independent on the state. Moreover it can be proved that the system (5.1) is periodic stabilizable if and only if there exists $M \in \mathbb{N}$ and $i \in \mathcal{I}^M$ such that \mathbb{A}_i is Schur, see [Sun and Ge, 2011].

Proposition 5.3.4 *The existence of a stabilizing periodic switching law is sufficient but not necessary for the stabilizability of the system (5.1).*

The proof, given in ([Fiacchini et al., 2016a]), is based on the fact that the existence of a stabilizing periodic switching law implies the satisfaction of the LMI condition, one might wonder if there exists an equivalence relation between periodic stabilizability and condition (5.18). The answer is provided below.

Theorem 5.3.5 *A stabilizing periodic switching law for the system (5.1) exists if and only if condition (5.18) holds.*

Notice that, although periodic stabilizability and condition (5.18) are equivalent from the stabilizability point of view, the computational aspects and the resulting controls are different. Indeed, the first consists of an eigenvalue test for a number of matrices exponential in M , while condition (5.18) is an LMI that grows exponentially with N . Finally, notice that the periodic law is in open loop whereas (5.18) leads to a state-dependent switching law.

5.3.3 Stabilizability conditions relations

A characterization of the relations between the different stabilizability conditions presented and recalled so far is presented hereafter. First, a relation with the generalized Lyapunov-Metzler condition (5.15) is provided. Recall that the Lyapunov-Metzler condition regards nonconvex sets and sequences of length one (possibly of extended systems) whereas the LMI one concerns quadratic Lyapunov functions and switching control sequences. It can be proved that the LMI sufficient condition (5.18) holds if and only if the generalized Lyapunov-Metzler one can be satisfied.

Theorem 5.3.6 *There exist $M \in \mathbb{N}$, $P_i \succ 0$, with $i \in \mathcal{I}^{[1:M]}$, and $\pi \in \mathcal{M}_{\bar{M}}$ such that (5.15) holds if and only if there exists $N \in \mathbb{N}$ and $\eta \in \mathbb{R}^{\bar{N}}$ such that $\eta \geq 0$, $\sum_{i \in \mathcal{I}^{[1:N]}} \eta_i = 1$ and (5.18) holds.*

Note that, even though (5.15) and (5.18) are equivalent, they generally hold for different values of M and N , with $N \geq M$, from the proof of Theorem 5.3.6 given in [Fiacchini et al., 2016a].

It is proved hereafter that the condition for stabilizability given by Theorem 5.3.3 and Proposition 5.3.2 are equivalent. It is, nevertheless, worth recalling that the former is in LMI form whereas the latter involves BMIs.

Theorem 5.3.7 *For every $i \in \mathcal{I}$ there exist: the indices $\mathcal{K}_i = \mathbb{N}_{h_i}$, with $h_i \in \mathbb{N}$; the matrices $P_k^{(i)} \succ 0$, with $k \in \mathcal{K}_i$; and $\pi_{m,k}^{(p,i)} \in [0, 1]$, satisfying (5.16) for all $k \in \mathcal{K}_i$, such that (5.17) holds if and only if there exists $N \in \mathbb{N}$ and $\eta \in \mathbb{R}^{\bar{N}}$ such that $\eta \geq 0$, $\sum_{i \in \mathcal{I}^{[1:N]}} \eta_i \geq 1$ and (5.18) holds.*

Therefore, allowing to employ a set of ellipsoids $P_k^{(i)}$ for every mode $i \in \mathcal{I}$, leads to BMI Lyapunov-Metzler-like conditions equivalent to the LMI one. Nevertheless, it has been proved in [Fiacchini and Jungers, 2014] that such equivalence is lost for the classical Lyapunov-Metzler condition, i.e. if one considers a single matrix P_i for each mode, as in (5.14). See the Example 5.3.1.1 which shows that the LMI condition (5.18) can hold for a system while the Lyapunov-Metzler one does not.

The implications between the stabilizability conditions are summarized in the diagram in Figure 5.8. Remark that, compared to the classical Lyapunov-Metzler inequalities, the LMI condition concerns a convex problem and it is less conservative. On the other hand, the dimension of the LMI problem might be consistently higher than the BMI one.

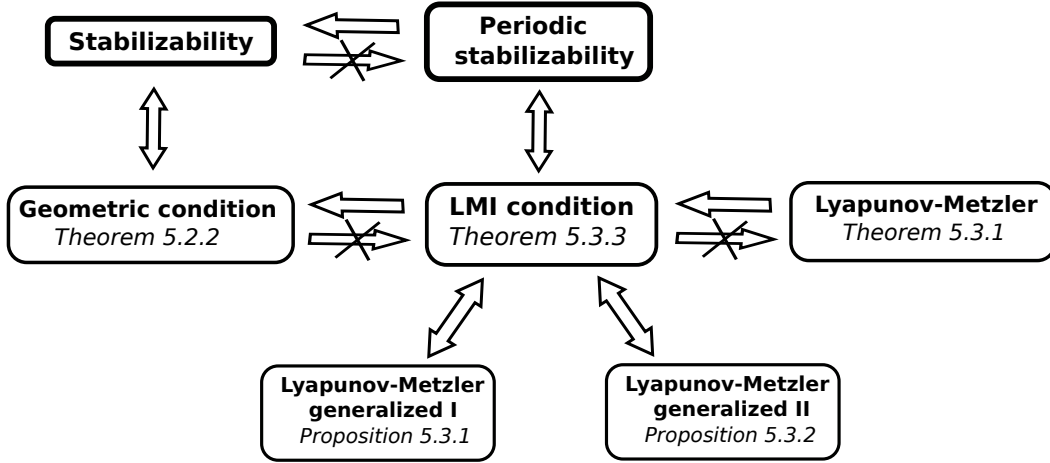

Figure 5.8: Implications diagram of stabilizability conditions.

Two numerical examples illustrating the relations between the different stabilizability conditions are presented here in detail.

5.3.3.1 Example

Consider the system (5.1) with $q = 2$, $n = 2$, $x_0 = [-3, 3]^T$ and the non-Schur matrices

$$A_1 = 1.01 R\left(\frac{\pi}{5}\right), \quad A_2 = \begin{bmatrix} -0.6 & -2 \\ 0 & -1.2 \end{bmatrix}.$$

with $R(\theta)$ as in (5.12). Four different stabilizing switching laws are designed and compared

- the geometric condition given in Theorem 5.2.2, which proves the stabilizability of the systems;
- the min-switching strategy (5.21)-(5.23) related to a solution of the LMI condition (5.18);
- the switching control law given in Proposition 5.3.3;
- the periodic switching law, that exists from Theorem 5.3.5.

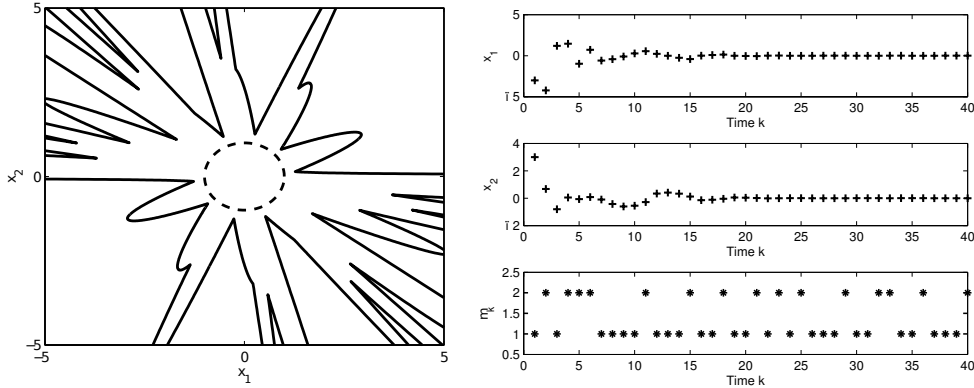

Figure 5.9: Left: sets \mathcal{B} (dashed) and $\bigcup_{i \in \mathcal{I}[1:N]} \mathcal{B}_i$ (solid). Right: State evolution and switching control induced by the geometric condition (5.7).

As noticed in [Geromel and Colaneri, 2006b, Fiacchini and Jungers, 2014], for systems with $q = 2$ the Lyapunov-Metzler inequalities become two linear matrix inequalities once two parameters, both contained in $[0, 1]$, are fixed. Such LMIs have been checked for this example to be infeasible on a grid of these two parameters, with step of 0.01. It is then reasonable to conclude that the Lyapunov-Metzler inequalities are infeasible for this numerical example. Furthermore it is evident that the computational complexity is unmanageable as q increases. Recall moreover that, to circumvent the conservatism proper of the classical Lyapunov-Metzler inequalities with respect to the LMI condition (5.18), one should increase the problem dimension, see Propositions 5.3.1 and 5.3.2. Therefore, employing Lyapunov-Metzler inequalities to prove stabilizability might often be computationally intractable, also for systems with few modes.

An iterative procedure is applied to determine $N \in \mathbb{N}$ such that (5.7) is satisfied. The result is that (5.7) holds with $N = 5$ and then the homogeneous function induced by the set represented in Figure 5.9, left, is a control Lyapunov function and the related min-switching rule is a stabilizing law. The state evolution and the switching law are depicted in Figure 5.9, right.

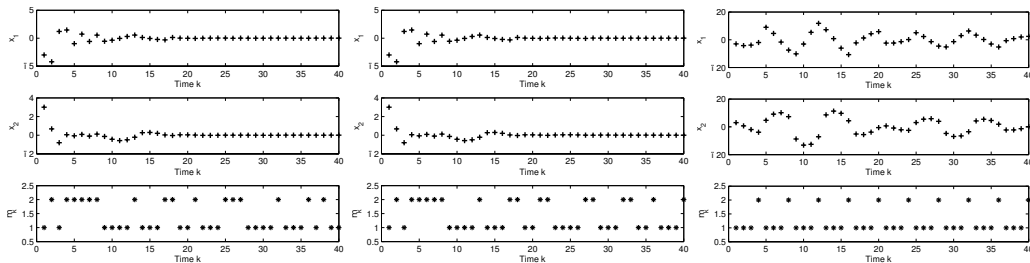

Figure 5.10: State evolution and min-switching control (5.21)-(5.23), left; min-switching control (5.26), center, and periodic switching control with $M = 4$, right.

The LMI condition (5.18) is solved with $N = 7$ and the min-switching law (5.21)-(5.23) is applied to the system at first. The control results in the concatenation of elements of $\mathcal{I}^{[1,7]}$, respectively of lengths $\{7, 6, 5, 7, 7, \dots\}$. The time-varying length of the switching subsequences is a consequence of the state dependence of the min-switching strategy. The resulting behavior is depicted in Figure 5.10, left. Then, the control law defined in Proposition 5.3.3, namely (5.26) with $\lambda = 0.9661$, is applied and the result is shown in Figure 5.10, center. The value of λ is obtained by solving the optimization problem described after Proposition 5.3.3.

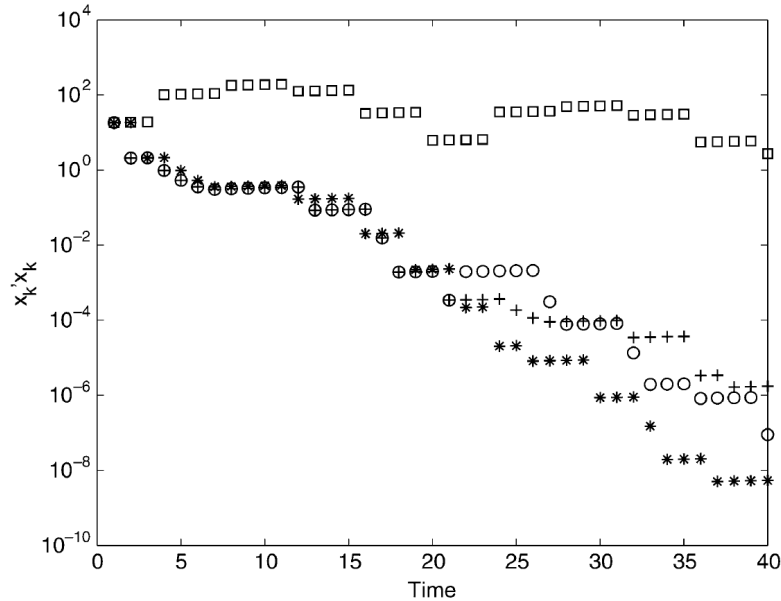

Figure 5.11: Comparison between the evolution of the Euclidean norm of the state for the different switching laws: induced by geometric condition (5.7) (star); min-switching law (5.21)-(5.23) (cross); min-switching control (5.26) (circle) and periodic rule (square).

The periodic switching law of length $M = 4$ is then obtained, by searching the shorter sequence of switching modes which yields a Schur matrix A_i . The resulting evolution is represented in Figure 5.10, right.

A comparison between the different switching laws is provided in Figure 5.11, where the time-evolution of the Euclidean distance of the state from the origin is depicted. Recall that, although every switching rule entails the exponential decreasing of an homogeneous function, each law is induced by different sets, potentially nonconvex. For this reason the Euclidean norm is chosen as a common measure to compare the convergence performances.

Notice in Figure 5.11, that the higher convergence rate seems to be obtained for the geometric approach, which is reasonable since it has been proved to be given by the less conservative stabilizability condition. The lower convergence speed is provided for this example by the periodic switching rule, which might reflect the fact that such switching rule does not employ the information on the state but depends only on time. Finally, the min-switching rules induced by the LMI condition (5.18) provide an average performance, due to their state-feedback nature on one side and to the conservatism with respect to the geometric condition related law, on the other.

5.3.3.2 Example

Consider the 3D numerical Example 5.2.2.4, with $q = 2$ and $n = 3$. Matrices A_1 and A_2 are not Schur, but the product $A_1 A_2$ is Schur and induces the existence of a 2-periodic stabilization law.

The geometric condition holds for $N = 3$. By applying Theorem 5.3.3, the LMI (5.18) is infeasible for $N = 1, 2, 3$ but feasible for $N = 4$, then the dimension of η is given by $\bar{N} = \bar{4} = 30$ (see η depicted in Figure 5.12).

It is noteworthy that the solution obtained by the LMI solver is not unique. Guided by the three main values of the weighting vector η , another solution of LMI (5.18) is given by

$$0.3460 \mathbb{A}_{(1;1;2;1)}^T \mathbb{A}_{(1;1;2;1)} + 0.1753 \mathbb{A}_{(1;1;2;2)}^T \mathbb{A}_{(1;1;2;2)} + 0.4787 \mathbb{A}_{(1;2;1;2)}^T \mathbb{A}_{(1;2;1;2)} \prec I_3,$$

implying that three sequences of modes of length 4 among the 30 are sufficient to stabilize the system.

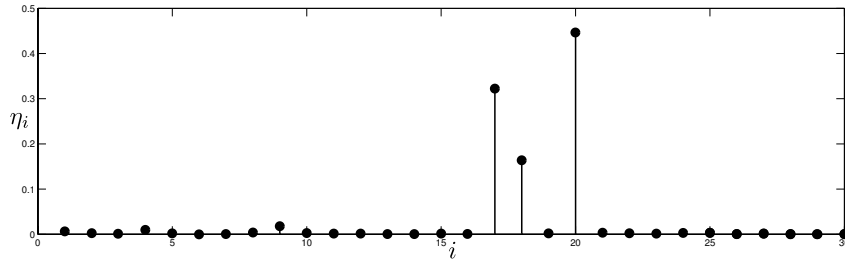

Figure 5.12: A vector $\eta \in \mathbb{R}^{30}$ solution of the LMI (5.18) for Example 5.3.3.2.

5.4 Computation-oriented condition

Consider the switched linear system (5.1), the objective is now to provide a constructive condition for stabilizability, defined below for the case under analysis. The main issue affecting the necessary and sufficient conditions (5.6) and (5.7) being the inherent computational complexity, in fact, the objective of this section is to provide a computational method for obtaining a test for stabilizability which is less conservative than the sufficient ones, in the line of [Jungers and Mason, 2017], and to show its efficiency even in four dimensions.

A first novel necessary and sufficient condition for stabilizability is presented below. Based on this condition, another one, more computation oriented, is given afterward, in which, recall, ∇^n denotes the simplex in \mathbb{R}^n , see Notation section.

Theorem 5.4.1 *The switched system (5.1) is stabilizable if and only if there exists $N \in \mathbb{N}$ and, for every $x \in \mathbb{R}^n$, there is $\eta(x) \in \mathbb{R}^{\bar{N}}$ such that $\eta(x) \in \nabla^{\bar{N}}$ and*

$$x^T \left(\sum_{i \in \mathcal{I}^{[1;N]}} \eta_i(x) \mathbb{A}_i^T \mathbb{A}_i \right) x < x^T x. \quad (5.27)$$

Theorem 5.4.1 substantially claims that the existence of $\eta(x) \in \nabla^{\bar{N}}$ such that (5.27) is satisfied, for every $x \in \mathbb{R}^n$, is necessary and sufficient for the stabilizability of the switched linear system. On the other hand, the determination of such $\eta(x)$ defined on the whole \mathbb{R}^n might be computationally

intractable. Note that the sufficient condition (5.18) can be seen as the particular case of (5.27) with $\eta = \eta(x)$ for all $x \in \mathbb{R}^n$.

The alternative computation-oriented necessary and sufficient condition can now be given.

Theorem 5.4.2 *The switched system (5.1) is stabilizable if and only if there exist: $N \in \mathbb{N}$; a conic cover $\{\mathcal{C}^{(j)}\}_{j \in \mathbb{N}_p}$ of \mathbb{R}^n ; and $\{\mu^{(j)}\}_{j \in \mathbb{N}_p}$ with $\mu^{(j)} \in \nabla^{\bar{N}}$ such that*

$$x^T \left(\sum_{i \in \mathcal{I}^{[1:N]}} \mu_i^{(j)} \mathbb{A}_i^T \mathbb{A}_i \right) x < x^T x, \quad \forall x \in \mathcal{C}^{(j)}. \quad (5.28)$$

Theorem 5.4.2 means that the existence of a fine enough conic cover of the space such that (5.28) holds is a necessary and sufficient condition for stabilizability. Moreover, condition (5.28) boils down to a linear condition if the conic sets $\mathcal{C}^{(j)}$ are defined as the negative sublevel sets of quadratic forms, as will be illustrated below. More details on the computational implication will be given in the following section.

Being the condition given in Theorem 5.4.2 necessary and sufficient for stabilizability, it is equivalent to the other ones, [Sun and Ge, 2011, Fiacchini and Jungers, 2014], and strictly less conservative than sufficient conditions, for instance those based on convex conditions [Sun and Ge, 2011, Fiacchini et al., 2016a], on nonconvex Lyapunov-Mezler conditions [Geromel and Colaneri, 2006b, Geromel and Colaneri, 2006a]. The relations between some of them, presented in Section 5.3, are given in [Fiacchini et al., 2016a]. Moreover, the satisfaction of the condition in Theorem 5.4.2, as for the equivalent ones, implies that the classical min-switch control strategies stabilize the switched system.

5.4.1 Conic partition and nonnegative quadratic forms

The first issue is how to compute a set of quadratic forms determining a cover of the whole space, on whose cones condition (5.28) has to be tested. That is, the design of a set of matrices $\{M_j\}_{j \in \mathbb{N}_p}$ such that

$$\bigcup_{j \in \mathbb{N}_p} \{x \in \mathbb{R}^n : x^T M_j x \geq 0\} = \mathbb{R}^n. \quad (5.29)$$

Moreover, it might be necessary to iteratively generate finer covers of the state space.

The presented method is based on generating covers of the state space composed by the closed convex cones determined by a basis matrix. Hence, for every cone, a quadratic form that is nonnegative on the cone is defined. Finally a method to generate finer covers of the state space, by replacing a cone with a conic cover of it, is given.

5.4.1.1 Initial conic partition generation

Any basis of the state space is the linear transformation of the standard basis of \mathbb{R}^n , denoted $\{e_i\}_{i \in \mathbb{N}_n}$. Indeed, clearly, the elements of any given basis $\{b_i\}_{i \in \mathbb{N}_n}$ with $b_i \in \mathbb{R}^n$ are $Be_i = [b_1 \ b_2 \ \dots \ b_n]e_i = b_i$, for all $i \in \mathbb{N}_n$. Moreover, given a nonsingular matrix $B \in \mathbb{R}^{n \times n}$ the set

$$C(B) = \{x \in \mathbb{R}^n \mid \exists \lambda \in \mathbb{R}^n : B\lambda = x, \lambda \geq 0\} \quad (5.30)$$

is a closed convex cone. Then given the basis $\{b_i\}_{i \in \mathbb{N}_n}$ of \mathbb{R}^n , the closed convex cones $C(BT(\beta))$ defined for all $\beta \in J^n$, are such that $\bigcup_{\beta \in J^n} C(BT(\beta)) = \mathbb{R}^n$. Thus, every nonsingular matrix B defines a conic partition of \mathbb{R}^n , that will be used in the algorithm as initial partition.

5.4.1.2 Nonnegative quadratic form

Given $\beta \in J^n$ and the cone $C(BT(\beta))$, a quadratic form that is nonnegative on $C(BT(\beta))$ must be defined. Given $\beta \in J^n$, denote $V = BT(\beta)$ in this section, to ease notation.

Lemma 5.4.1 *Given $\{v_i\}_{i \in \mathbb{N}_n}$ basis of \mathbb{R}^n and $V = [v_1 \ v_2 \ \dots \ v_n]$, if $M(V) \in \mathbb{R}^{n \times n}$ symmetric satisfies*

$$v_i^T M(V) v_j \geq 0, \quad \forall i, j \in \mathbb{N}_n \text{ s.t. } i \leq j \quad (5.31)$$

then $x^T M(V) x \geq 0$ for all $x \in C(V)$.

Lemma 5.4.1 can be used to determine a quadratic form that is nonnegative on the cone generated by every $\{v_i\}_{i \in \mathbb{N}_n}$ basis of \mathbb{R}^n . Recall that $M(V)$ might not be positive definite to determine nontrivial cones.

Proposition 5.4.1 *Given $\{v_i\}_{i \in \mathbb{N}_n}$ basis of \mathbb{R}^n and $V = [v_1 \ v_2 \ \dots \ v_n]$ the following inclusion holds*

$$C(V) \cup C(-V) \subseteq \{x \in \mathbb{R}^n : x^T M(V) x \geq 0\} \quad (5.32)$$

for all $M(V)$ satisfying (5.31).

From Proposition 5.4.1, some of the sets in the cover $\bigcup_{\beta \in J^n} C(BT(\beta))$ could be disregarded from the analysis, since redundant.

5.4.1.3 Finer partition generation

As it will be clearer from the following section, a method is necessary to split a closed convex cone $C(V)$ in smaller cones whose union contains $C(V)$. In particular, given the nonsingular matrix V , a first method is provided for determining n nonsingular matrices U_j , with $j \in \mathbb{N}_n$ such that

$$C(V) = \bigcup_{j \in \mathbb{N}_n} C(U_j). \quad (5.33)$$

The simpler approach proposed consists basically in using the barycenter vector $\bar{v}(V) = 1/n \sum_{j \in \mathbb{N}_n} v_j$ to split the cone:

$$U_j = [v_1 \ \dots \ v_{j-1} \ \bar{v}(V) \ v_{j+1} \ \dots \ v_n] \quad \forall j \in \mathbb{N}_n. \quad (5.34)$$

As $\bar{v}(V)$ belongs to the convex hull of $\{v_i\}_{i \in \mathbb{N}_n}$ and matrices U_j are nonsingular, for every $j \in \mathbb{N}_n$, then their columns are basis of \mathbb{R}^n and satisfy (5.33). This means that, given a conic partition of \mathbb{R}^n , another partition of \mathbb{R}^n is obtained by replacing the cone $C(V)$ with the cones $C(U_j)$ as in (5.34).

Alternatively, a cone can be splitted along the longer edge of the set $\text{co}(\{v_j\}_{j \in \mathbb{N}_n})$. This consists in defining

$$(i^*, j^*)(V) \in \arg \max_{(i,j) \in \mathbb{N}_n^2} \|v_i - v_j\|, \quad (5.35)$$

$$v^*(V) = 0.5(v_{i^*} + v_{j^*})$$

to split the cone in two

$$\begin{aligned} U_{i^*} &= [v_1 \ \dots \ v_{i^*-1} \ v^*(V) \ v_{i^*+1} \ \dots \ v_n], \\ U_{j^*} &= [v_1 \ \dots \ v_{j^*-1} \ v^*(V) \ v_{j^*+1} \ \dots \ v_n]. \end{aligned} \quad (5.36)$$

Also in this case matrices U_{i^*} and U_{j^*} are nonsingular and satisfy $C(V) = C(U_{i^*}) \cup C(U_{j^*})$. Moreover, the maximal distances between the vectors v_j determining a partition would converge to zero by iterating the splitting procedure.

5.4.2 Local contraction constraint and algorithm

Now that a conic partition is given and a quadratic form that is nonnegative on every cone can be determined, the contraction conditions can be posed over every cone. Suppose that a set of basis $\mathcal{V} = \{V^{(j)}\}_{j \in \mathbb{N}_p}$ determining the cover of \mathbb{R}^n as $\bigcup_{j \in \mathbb{N}_p} C(V^{(j)})$ has been obtained as illustrated above, i.e. starting with an initial cover and then refining it if necessary. Also the following set of cones

$$\bigcup_{j \in \mathbb{N}_p} \{x \in \mathbb{R}^n : x^T M(V^{(j)})x \geq 0\}$$

is a cover of \mathbb{R}^n , from Proposition 5.4.1.

Proposition 5.4.2 *Given $\{v_i\}_{i \in \mathbb{N}_n}$ basis of \mathbb{R}^n and $V = [v_1 \ v_2 \ \dots \ v_n]$, the condition (5.28) is satisfied with $\mathcal{C}^{(j)} = C(V) \cup C(-V)$ and $\mu^{(j)} = \mu(V)$ if*

$$\sum_{i \in \mathcal{I}^{[1:N]}} \mu_i(V) \mathbb{A}_i^T \mathbb{A}_i - I + M(V) \prec 0, \quad (5.37)$$

holds with $M(V)$ satisfying (5.31).

The interest of this result lies in the fact that (5.37) is more suitable than (5.28) from the computational point of view.

A sketch of algorithm is given for testing whether the condition in Theorem 5.4.2 is satisfied and hence if the system (5.1) is stabilizable, see Algorithm 4. If Algorithm 4 terminates, then the system is stabilizable.

Algorithm 4 Testing stabilizability condition in Theorem 5.4.2.

Input: Horizon $N \in \mathbb{N}$, matrices $\{A_i\}_{i \in \mathcal{I}^{[1:N]}}$, basis matrix $B, \mathcal{V} = \{BT(\beta) : \beta \in J^n\}$;

Initial conic partition

while $\mathcal{V} \neq \emptyset$ **do:**

extract V from \mathcal{V} ;

compute $\alpha(V)$ such that:

$$\begin{aligned} \alpha(V) &= \min_{\alpha, \mu(V), M(V)} \alpha \\ \text{s.t.} \quad & \sum_{i \in \mathcal{I}^{[1:N]}} \mu_i(V) \mathbb{A}_i^T \mathbb{A}_i + M(V) \preceq \alpha I \\ & \mu(V) \geq 0, \quad \sum_{i \in \mathcal{I}^{[1:N]}} \mu_i(V) = 1, \quad M(V) = M(V)^T \\ & v_i^T M(V) v_j \geq 0, \quad \forall i \leq j, \end{aligned}$$

if $\alpha(V) \geq 1$ **then:**

add U_{i^*} and U_{j^*} to \mathcal{V} ;

Partition refinement

endif

endwhile

The computation-oriented conditions presented above, as well as the Algorithm 4, can be adapted to determine, besides the property of stabilizability, also bounds on the exponential convergence rate λ , sometimes referred to as stabilization radius [Jungers and Mason, 2017]. It is sufficient, indeed, to multiply all the matrices by $1/\lambda$ in the stabilizability conditions. If the condition holds, then the system has a convergence rate bounded above by λ , see Examples 5.4.2.1 and 5.4.2.2 below.

A convex problem, in LMI form, has to be solved at every iteration. On the other hand, there is no guarantee, in general, of finite termination of Algorithm 4, as the existence of a conic partition cannot be ensured unless the system is stabilizable. This is reasonable since the problem is undecidable by its nature. Moreover, the number of elements in an eventual conic partition satisfying the necessary and sufficient condition could be arbitrarily big. Nonetheless, as illustrated in the next section, the application of Algorithm 4 to examples from the literature and to a four dimensional system shows the efficiency of the algorithm in testing stabilizability and computing tight bounds on the exponential convergence rate.

Three examples will be considered to illustrate the results and the application of the algorithm. The set of matrices $M(V)$, determining the conic cover, and the parameters $\alpha(V)$ and $\mu(V)$ resulting from the application of Algorithm 4 for each example are available at [Fiacchini, M.,], in form of matlab data files, together with simple scripts to verify the conic covering of the space and the stabilizability condition (5.37) satisfaction.

5.4.2.1 Example

Consider Example 5.3.2.1, taken from in [Fiacchini et al., 2016a], employed to prove that condition (5.18) is just sufficient for stabilizability. The system is given by three modes with matrices

$$A_1 = AR(0), \quad A_2 = AR\left(\frac{2\pi}{3}\right), \quad A_3 = AR\left(\frac{-2\pi}{3}\right),$$

where

$$A = \begin{bmatrix} 0.6 & 0 \\ 0 & 0.6^{-1} \end{bmatrix}.$$

with $R(\theta)$ as in (5.12). The system is proved in [Fiacchini et al., 2016a] to be stabilizable since the necessary and sufficient condition (5.7) is satisfied with $N = 1$. Then, the Euclidean norm decreases at every step, but (5.18) does not hold, for any $N \in \mathbb{N}$. This implies also that Lyapunov-Metzler conditions cannot validate stabilizability either.

Algorithm 4 with $N = 1$ and the identity as initial basis matrix, i.e. $B = I$, has been applied to this example, validating the stabilizability with a final cover of 8 cones $\{V^{(j)}\}_{j \in \mathbb{N}_8}$, depicted in Figure 5.13. Figure 5.13 represents also the sets \mathcal{B} and its preimages $\mathcal{B}_1, \mathcal{B}_2$ and \mathcal{B}_3 that graphically validate condition (5.7) with $N = 1$. Note that from Proposition 5.4.1, it is sufficient to generate a cover of half of the space \mathbb{R}^2 .

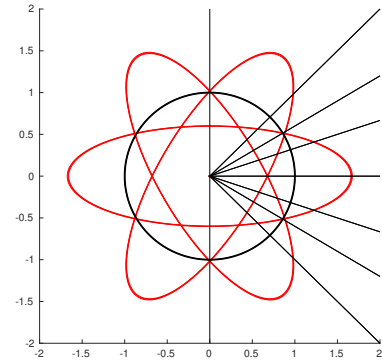

Figure 5.13: Set \mathcal{B} , black, ellipsoidal preimages $\mathcal{B}_1, \mathcal{B}_2$ and \mathcal{B}_3 , in red, and basis vectors of $\{V^{(j)}\}_{j \in \mathbb{N}_8}$, in thin lines.

5.4.2.2 Example

The second switched system, with modes

$$A_1 = R\left(\frac{\pi}{4}\right), \quad A_2 = \begin{bmatrix} 2 & 0 \\ 0 & 1/2 \end{bmatrix} \quad (5.38)$$

is based on an example from [Stanford and Urbano, 1994] and used in [Jungers and Mason, 2017] to illustrate methods for computing bounds of the stabilizability radius. These methods, based on conditions evaluated on a grid of the unit circle in \mathbb{R}^2 , hence on a one dimensional space, provides two bound estimations, of 0.886 and 0.88.

To infer the value of the convergence rate λ , consider the system whose matrices are given by $\bar{A}_1 = \lambda^{-1}A_1$ and $\bar{A}_2 = \lambda^{-1}A_2$. For $N = 9$ and $\lambda = 0.8855$ the set \mathcal{B} and the preimages \mathcal{B}_i for all $\mathcal{I}^{[9]}$, whose number is $\bar{N} = 1022$, are drawn, see Figure 5.14. From geometric inspection it can be

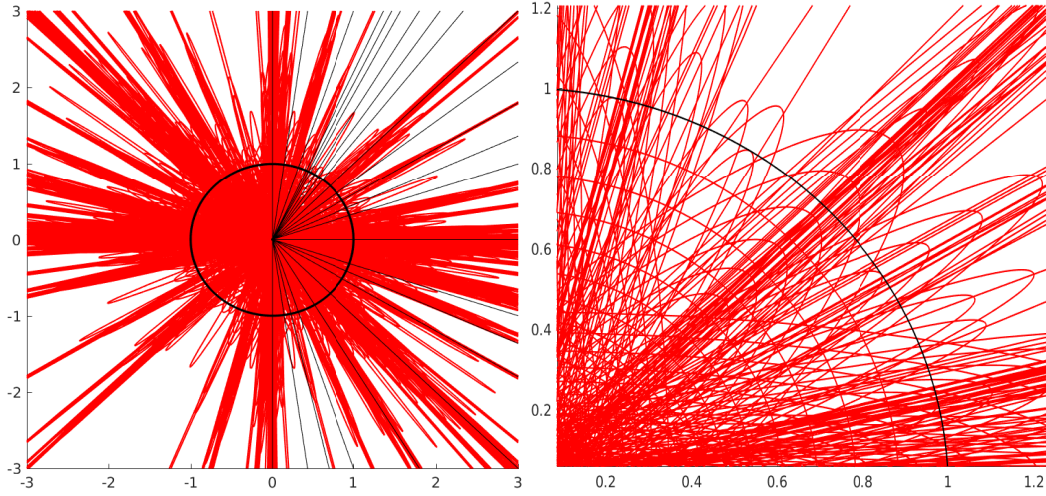

Figure 5.14: Set \mathcal{B} , black, ellipsoidal preimages \mathcal{B}_i for $i \in \mathcal{I}^{[9]}$, in red, and basis vectors of $\{V^{(j)}\}_{j \in \mathbb{N}_{23}}$, in black lines. Zoom on the right.

proved that \mathcal{B} is contained in the union of ellipsoids and $\lambda = 0.8855$ seems a rather tight bound for $N = 9$, see the Figure 5.14 right.

Algorithm 4 is then applied with $B = I$, validating the condition of stabilizability with convergence rate of $\lambda = 0.8855$ by testing the convex condition over 23 cones covering the half space, also depicted in Figure 5.14.

Comparing this result with those obtained in [Jungers and Mason, 2017] it is worth noting that, besides providing a tighter bound with respect to one proposed, the method presented here provides guarantee of stabilizability, that cannot be ensured in general when evaluating conditions on a grid of points. Another benefit is the fact that, as the proposed method does not resort to a grid of the space, it can be applied to higher dimensional systems, as illustrated in the next example. For this, the algorithm has also been applied to this example with $N = 5$, leading to the validation of a bound of $\lambda = 0.96$ with 10 cones.

5.4.2.3 Example

This example is specifically built such that a tight estimate of the convergence rate is known but other methods for its sharp estimation, based on the space gridding, might be not applicable due to the space dimension. To illustrate the possibility of applying the proposed method in higher dimension, in fact, a system is considered that is composed by two subsystems equal to the one of Example 5.4.2.2. Any method based on gridding the space is hardly applicable in \mathbb{R}^4 . Moreover, an accurate estimation of the convergence rate is known by construction, and then the precision of the estimation obtained with Algorithm 4 can be objectively evaluated. Consider the four dimensional system with 4 modes

$$\hat{A}_1 = \begin{bmatrix} \lambda^{-1}A_1 & 0 \\ 0 & \delta I \end{bmatrix}, \quad \hat{A}_2 = \begin{bmatrix} \lambda^{-1}A_2 & 0 \\ 0 & \delta I \end{bmatrix}, \quad \hat{A}_3 = \begin{bmatrix} \delta I & 0 \\ 0 & \lambda^{-1}A_1 \end{bmatrix}, \quad \hat{A}_4 = \begin{bmatrix} \delta I & 0 \\ 0 & \lambda^{-1}A_2 \end{bmatrix},$$

with λ the known estimation of the convergence rate, see below, and A_1 and A_2 as in (5.38). Parameter δ is posed equal to 0.999, to guarantee a decreasing of the function $x^T x$ within the horizon N of the four dimensional system. The objective is to check whether Algorithm 4 is able to validate the convergence rate for the four dimensional system.

Since $N = 9$, with $q = 4$, leads to more than a half million of sequences, the smaller horizon

of $N = 5$ has been employed. Note that $N = 5$ gives $\bar{N} = 1364$ switching elements in $\mathcal{I}^{[5]}$. Since the bound of $\lambda = 0.96$ has been validated in the previous example for the single subsystem, it must hold also for the four dimensional system. The objective is to test whether the tight bound $\lambda = 0.96$ for $N = 5$ can be validated also in this case.

Indeed, the application of Algorithm 4, with a randomly generated non-singular matrix B , provides a validation of the bound $\lambda = 0.96$ for the four dimensional system, the semidefinite conditions (5.37) holding in each of the 1827 cones composing the generated cover of \mathbb{R}^4 .

5.5 Control co-design

Consider here the discrete-time switched linear system with control input

$$x_{k+1} = A_{\sigma_k} x_k + B_{\sigma_k} u_k, \quad (5.39)$$

where $x_k \in \mathbb{R}^n$ and $u_k \in \mathbb{R}^m$ are the state and the control input at time $k \in \mathbb{N}$, respectively; $\sigma : \mathbb{N} \rightarrow \mathcal{I}$ is the switching law and $\{A_i\}_{i \in \mathcal{I}}$ and $\{B_i\}_{i \in \mathcal{I}}$, with $A_i \in \mathbb{R}^{n \times n}$ and $B_i \in \mathbb{R}^{n \times m}$ for all $i \in \mathcal{I}$. A time-varying control policy $\nu : \mathbb{R}^n \times \mathbb{N} \rightarrow \mathcal{I} \times \mathbb{R}^{m \times n}$, is such that $\nu(x, k) = (\sigma(x, k), K(x, k)) \in \mathcal{I} \times \mathbb{R}^{m \times n}$, where $K(x, k)$ is the state feedback gain, i.e. such that $u_k(x_k) = K(x_k, k)x_k$ and then the feedback law may change at every instant.

As proved in [Zhang et al., 2009], see Theorems 5 and 7 in particular, the attention can be restricted without loss of generality to static control policies of the form

$$\nu(x) = (\sigma(x), K(x)) \in \mathcal{I} \times \mathbb{R}^{m \times n}, \quad (5.40)$$

such that $\nu(ax) = \nu(x)$ for all $x \in \mathbb{R}^n$ and $a \in \mathbb{R}$, and to piecewise quadratic Lyapunov functions. Moreover $K(x)$ belongs to a finite set i.e. $K(x) \in \mathcal{K} = \{\kappa_i\}_{i \in \mathbb{N}_M}$, with $M \in \mathbb{N}$.

The switched system in closed loop with (5.40) reads

$$x_{k+1} = (A_{\sigma(x_k)} + B_{\sigma(x_k)}K(x_k))x_k, \quad (5.41)$$

where $\sigma(x_k) = \sigma_k$. Denote with $x_k^\nu(x_0) \in \mathbb{R}^n$ the state of the system (5.39) at time k starting from $x(0) = x_0$ by applying the control policy ν . Given $\sigma \in \mathcal{I}^D$ denote with $x_k^\sigma(x_0)$ the state of (5.41) at time $k \leq D$ starting at x_0 under the switching sequence σ . The dependence of x_k^ν and x_k^σ on the initial conditions will be dropped when clear from the context.

Definition 5.5.1 *The system (5.39) is globally exponentially stabilizable if there are a control policy $\nu(x)$ as in (5.40), $c \geq 0$ and $\lambda \in [0, 1)$ such that $\|x_k^\nu(x_0)\| \leq c\lambda^k\|x_0\|$, for all $x_0 \in \mathbb{R}^n$, with x_k state of (5.41).*

Hereafter the focus is posed on a condition analogous to the LMI one (5.18) for the controlled switched system (5.39). The aim is to provide an LMI problem whose solution determines a stabilizing control policy (5.40) for periodic stabilizable systems.

5.5.1 Switching law and feedback control co-design

As noticed above, the problem of co-design is equivalent to determine a stabilizing static control policy as in (5.40), with finite number of feedback gains, and a piecewise quadratic Lyapunov function for the system (5.41). The first step is to apply the result in Theorem 5.3.5 for the co-design. This would lead to a non-static stabilizing control policy, as the control would result in sequences of modes and gains. Then a static control policy of the form (5.40) will be determined.

Applying Theorem 5.3.5, the objective is to search for sequences of modes and feedback gains, fulfilling the LMI condition (5.18) in the context of co-design. That is, given a sequence $\vartheta \in \mathcal{I}^J$, of length J , and a time instant $j \in \mathbb{N}_J$, a gain among the finite set \mathcal{K} can be applied, denoted as K_j^ϑ and whose value has to be designed. Then, with a slight abuse of notation, given $J \in \mathbb{N}$ and a sequence $\vartheta \in \mathcal{I}^J$, denote

$$\mathcal{F}_\vartheta = \prod_{j=1}^J F_{\vartheta_j} = F_{\vartheta_J} \dots F_{\vartheta_1} = (A_{\vartheta_J} + B_{\vartheta_J} K_J^\vartheta) \dots (A_{\vartheta_1} + B_{\vartheta_1} K_1^\vartheta). \quad (5.42)$$

Thus a set of $N_{\mathcal{I}} = \sum_{k=1}^N q^k$ matrices \mathcal{F}_ϑ , one for every $\vartheta \in \mathcal{I}^{[1:N]}$, can be defined as in (5.42) that are parameterized in the gains $\{K_j^\vartheta\}_{j \in \mathbb{N}_{|\vartheta|}}$.

Control policy for (5.39) of the form (5.40) are considered, with $K(x)$ belongs to one of the elements of a sequence associated to a mode in $\mathcal{I}^{[1:N]}$. Then, $K(x)$ is a gain among the $\sum_{k=1}^N kq^k$ possible, i.e. $K(x) \in \mathcal{K}$ where

$$\mathcal{K} = \{\kappa_i\}_{i \in \mathbb{N}_M} = \{K_j^\vartheta \in \mathbb{R}^{m \times n} : \vartheta \in \mathcal{I}^{[1:N]}, j \in \mathbb{N}_{|\vartheta|}\}, \quad (5.43)$$

with $M = \sum_{k=1}^N kq^k$.

Given a switching law $\vartheta : \mathbb{N} \rightarrow \mathcal{I}$ and a sequence of feedback gains $K^\vartheta : \mathbb{N} \rightarrow \mathbb{R}^{m \times n}$, denote with $x_k^\vartheta(x)$ the state at time k starting at x if the control $\nu_k = (\vartheta_k, K_k^\vartheta)$ is applied at k for all $k \in \mathbb{N}$. Analogously to the case without control input, the concept of periodic ϑ -stabilizability can be given for the system (5.39).

Definition 5.5.2 *The system (5.39) is periodic ϑ -stabilizable if there exist: a periodic switching law $\vartheta : \mathbb{N} \rightarrow \mathcal{I}$ and a periodic sequence $K^\vartheta : \mathbb{N} \rightarrow \mathbb{R}^{m \times n}$, both of cycle length $D \in \mathbb{N}$; $c \geq 0$ and $\lambda \in [0, 1)$ such that $\|x_k^\vartheta(x)\| \leq c\lambda^k \|x\|$ holds for all $x \in \mathbb{R}^n$ and $k \in \mathbb{N}$.*

Clearly periodic ϑ -stabilizability is sufficient for exponential stabilizability of (5.39) as in Definition 5.5.1. From Definition 5.5.2 and Theorem 5.3.5, the LMI conditions

$$\sum_{i \in \mathcal{I}^{[1:N]}} \eta_i = 1 \quad (5.44)$$

and

$$\sum_{j \in \mathcal{I}^{[1:N]}} \eta_j \mathcal{F}_j^T \mathcal{F}_j \prec I. \quad (5.45)$$

are necessary and sufficient for periodic ϑ -stabilizability of system (5.39). Thus, conditions (5.45) provides the exact characterization of ϑ -stabilizability, together with (5.44).

A constructive necessary and sufficient LMI condition for the ϑ -stabilizability of switched systems (5.39) is given hereafter, together with the explicit form of the control law (5.40).

Theorem 5.5.1 *The switched system (5.39) is periodically ϑ -stabilizable if and only if there exist $N \in \mathbb{N}$; $\eta \in \mathbb{R}^{N_{\mathcal{I}}}$ such that $\eta > 0$ and (5.44) holds; and for every $j \in \mathcal{I}^{[1:N]}$ there are:*

- $|j| - 1$ nonsingular matrices $G_{j,k} \in \mathbb{R}^{n \times n}$, with $k \in \mathbb{N}_{|j|-1}$;
- $|j|$ matrices $Z_{j,k} \in \mathbb{R}^{m \times n}$ with $k \in \mathbb{N}_{|j|}$;
- a symmetric positive definite matrix $R_j \in \mathbb{R}^{n \times n}$;

such that

$$\begin{bmatrix} \eta_j I & X_{j,|j|} & 0 & \dots & 0 & 0 & 0 \\ X_{j,|j|}^T & Y_{j,|j|-1} & X_{j,|j|-1} & \dots & 0 & 0 & 0 \\ 0 & X_{j,|j|-1}^T & Y_{j,|j|-1} & \dots & 0 & 0 & 0 \\ \dots & \dots & \dots & \dots & \dots & \dots & \dots \\ 0 & 0 & 0 & \dots & Y_{j,2} & X_{j,2} & 0 \\ 0 & 0 & 0 & \dots & X_{j,2}^T & Y_{j,1} & X_{j,1} \\ 0 & 0 & 0 & \dots & 0 & X_{j,1}^T & R_j \end{bmatrix} \succ 0 \quad (5.46)$$

for every $j \in \mathcal{I}^{[1:N]}$ and

$$\sum_{j \in \mathcal{I}^{[1:N]}} R_j \prec I. \quad (5.47)$$

hold with

$$\begin{aligned} X_{j,1} &= \eta_j A_{j_1} + B_{j_1} Z_{j,1}, \\ X_{j,k+1} &= A_{j_{k+1}} G_{j,k} + B_{j_{k+1}} Z_{j,k+1}, & \forall k \in \mathbb{N}_{|j|-1}, \\ Y_{j,k} &= G_{j,k} + G_{j,k}^T, & \forall k \in \mathbb{N}_{|j|-1}, \end{aligned} \quad (5.48)$$

and feedback gains

$$\begin{aligned} K_1^j &= \eta_j^{-1} Z_{j,1}, \\ K_{k+1}^j &= Z_{j,k+1} G_{j,k}^{-1}, & \forall k \in \mathbb{N}_{|j|-1}, \end{aligned} \quad (5.49)$$

for every $j \in \mathcal{I}^{[1:N]}$.

Any solution of the conditions of Theorem 5.5.1, besides proving ϑ -stabilizability, provides a stabilizing control policy and a bound on the decreasing of the Euclidean norm every N steps at most, as summarized in the following theorem.

Theorem 5.5.2 *Suppose there exist $\alpha > 1$ and $N \in \mathbb{N}$; $\eta \in \mathbb{R}^{N \times}$ such that $\eta > 0$; matrices $G_{j,k} \in \mathbb{R}^{n \times n}$ with $k \in \mathbb{N}_{|j|-1}$, $Z_{j,k} \in \mathbb{R}^{m \times n}$ with $k \in \mathbb{N}_{|j|}$ and $R_j \in \mathbb{R}^{n \times n}$ as defined in Theorem 5.5.1 such that (5.46)-(5.47) and (5.48) hold and*

$$\sum_{i \in \mathcal{I}^{[1:N]}} \eta_i = \alpha. \quad (5.50)$$

Then system (5.39) is periodically ϑ -stabilizable and $\|\mathcal{F}_{\vartheta(x)}\|_2 < \lambda \|x\|_2$ holds for all $x \in \mathbb{R}^n$, with

$$\vartheta = \vartheta(x) = \arg \min_{j \in \mathcal{I}^{[1:N]}} (x^T \mathcal{F}_j^T \mathcal{F}_j x), \quad (5.51)$$

and $\lambda = \alpha^{-1/2}$. Given $x(t) = x$, the stabilizing control policy is defined from (5.49) within an horizon of length $|\vartheta|$ as

$$\nu(x, k) = (\sigma(x, k), K(x, k)) = (\vartheta_k, K_k^\vartheta) \quad (5.52)$$

to be applied at time $t + k - 1$, for all $k \in \mathbb{N}_{|\vartheta|}$.

From Theorem 5.5.2, the value of α , is related to λ and then could serve for obtaining the fastest decreasing rate, for a given N , by solving the following single LMI problem

$$\begin{aligned} \alpha = & \sup_{\alpha, \eta, G_{j,k}, Z_{j,k}, R_j} \sum_{j \in \mathcal{I}^{[1:N]}} \eta_j \\ \text{s.t.} & \quad (5.46) - (5.47) - (5.48), \end{aligned} \quad (5.53)$$

with $\eta, G_{j,k}, Z_{j,k}, R_j$ as defined in Theorem 5.5.1.

A nonconvex control Lyapunov function $V(x)$, decreasing at every step, and a state-dependent control policy $\nu(x)$, as given in Proposition 5.3.3 for the case of stabilizability, see also (5.40), can be defined as in [Fiacchini et al., 2016a] from the solution of the LMI problem:

$$V(x) = \min_{j \in \mathcal{Y}_N} (x^T \lambda^{-|j|} \mathcal{F}_j^T \mathcal{F}_j x), \quad (5.54)$$

where \mathcal{Y}_N is the set of all suffixes of the elements of $\mathcal{I}^{[1:N]}$, and the control policy is $\nu(x) = (\hat{j}_1(x), K_1^{\hat{j}(x)})$ with

$$\hat{j}(x) = \arg \min_{j \in \mathcal{Y}_N} (x^T \lambda^{-|j|} \mathcal{F}_j^T \mathcal{F}_j x). \quad (5.55)$$

5.5.2 Comparisons

In this section the presented co-design approach is compared with results from the literature, in terms of conservatism and complexity.

5.5.2.1 Comparison with switched LQR method

As a term of comparison for the methods, consider the nice results presented in [Zhang et al., 2009, Zhang et al., 2012] that are substantially based on the fact that a time-varying system is exponentially stabilizable if and only if the infinite-horizon LQR problem leads to a value function that is a control Lyapunov function. The method is based on a Riccati-like equation iteratively applied to generate an increasing set of gains and positive definite matrices that eventually provide the stabilizing LQR control and the related Lyapunov function. One main limitation is that the number of matrices generated might grow exponentially with the iterations, despite the criterion applied for reducing the redundancy is applied to limit the phenomenon. On the other hand, such a redundancy test would entail additional computational burden to the algorithm, already exponentially complex. Finally, a stop condition, in form of contraction test, must be checked at every iteration. Since the general condition could be overly complex, an only sufficient alternative, analogous to the one given in Theorem 5.3.5, is employed in the relaxed version of the algorithm.

Comparing the proposed result with the LQR-based ones, the most relevant feature is the fact that in the presented approach the feedback gains are design variables and are effectively computed by solving the LMI problem. That is, roughly speaking, while the set of gains in the LQR approach is exponentially increased through the iterations until a stabilizing control policy is achieved, in this method the sets of gains that maximizes the contraction, for a given horizon, are directly obtained. The benefits of this co-design approach are evident in the example below, taken from [Zhang et al., 2009, Zhang et al., 2012]. Moreover, also from the computational point of view, it seems that the co-design method presents some benefits.

Indeed, in spite of solving an exponentially increasing number of Riccati equations and convex optimization problems to reduce the redundancy, a single LMI problem has to be solved here. Furthermore, the proposed approach does not require a numerical search in the parameter space to obtain a solution. Finally, also from the point of view of the generality of the result, this approach is at least as general as the one proposed in [Zhang et al., 2009, Zhang et al., 2012]. In fact, the efficient algorithm stop condition is analogous to the LMI one given in Theorem 5.3.5, and then affected by the same conservatism of this approach with respect to the general stabilizability property. This means that every LQR-like solution can be recovered as a solution of the presented LMI-based approach.

5.5.2.2 Comparison with Lyapunov-Metzler-like conditions

The methods based on Lyapunov-Metzler conditions, as those in [Geromel and Colaneri, 2006b, Deaecto et al., 2011, Deaecto et al., 2015], seem to provide more conservative results, as the complexity of the Lyapunov function and control policy are fixed in function of the modes number. The conservatism is proved in the following example based on Example 27 in [Fiacchini et al., 2016a], used to prove analogous results for autonomous switched systems.

5.5.2.3 Example

Given $n = 3$ and $q = 2$, define

$$A_1 = \begin{bmatrix} 1 & 0 & 0 \\ 0 & 0.5 & 0 \\ 0 & 0 & a \end{bmatrix}, \quad A_2 = \begin{bmatrix} 4 & -4 & 0 \\ 4 & 4 & 0 \\ 0 & 0 & a \end{bmatrix}, \quad B_1 = B_2 = \begin{bmatrix} 0 \\ 0 \\ 1 \end{bmatrix}.$$

Clearly the subsystem x_3 is stabilized by $u = Kx_3$ with $|a + K| < 1$. The subsystem (x_1, x_2) is stabilizable through an appropriate switching sequence obtained by solving the LMI condition (5.18) but does not admit any solution to the Lyapunov-Metzler condition, see [Fiacchini et al., 2016a].

From the computational point of view, if on one side the Lyapunov-Metzler conditions are non-convex, in form of BMI, on the other one they involve a fixed number of matrices and then do not incur in the combinatorial complexity growth that affects the method present here and in [Zhang et al., 2009, Zhang et al., 2012].

5.5.2.4 Example

Consider Example 2 in [Zhang et al., 2009], that is the 4-dimensional system with 4 modes whose matrices are

$$A_1 = \begin{bmatrix} 0.5 & -1 & 2 & 3 \\ 0 & -0.5 & 2 & 4 \\ 0 & -1 & 2.5 & 2 \\ 0 & 0 & 0 & 1.5 \end{bmatrix}, \quad A_2 = \begin{bmatrix} -0.5 & -1 & 2 & 1 \\ 0 & 1.5 & -2 & 0 \\ 0 & 0 & 0.5 & 0 \\ -2 & -1 & 2 & 2.5 \end{bmatrix},$$

$$A_3 = \begin{bmatrix} 1.5 & 0 & 0 & 0 \\ 1 & 1 & 0.5 & -0.5 \\ 0 & 0.5 & 1 & -0.5 \\ 1 & 0 & 0 & 0.5 \end{bmatrix}, \quad A_4 = \begin{bmatrix} 0.5 & 1 & 0 & 0 \\ 0 & 0.5 & 0 & 0 \\ 0 & 0 & 0.5 & 0 \\ 0 & 2 & -2 & 0.5 \end{bmatrix},$$

$$B_1 = \begin{bmatrix} 1 \\ 2 \\ 3 \\ 4 \end{bmatrix}, \quad B_2 = \begin{bmatrix} 4 \\ 3 \\ 2 \\ 1 \end{bmatrix}, \quad B_3 = \begin{bmatrix} 4 \\ 3 \\ 2 \\ 1 \end{bmatrix}, \quad B_4 = \begin{bmatrix} 1 \\ 2 \\ 3 \\ 4 \end{bmatrix}.$$

The conditions of Theorem 5.5.2 are satisfied with horizon $N = 3$. Besides the inherent computational benefit of having a stabilization condition in form of LMI with respect to the algorithmic method presented in [Zhang et al., 2009], also the control obtained is substantially simpler and more efficient. Actually, in [Zhang et al., 2009] stabilizability is proved by means of an algorithm which inspects control horizons of length 7 resulting in a piecewise quadratic function determined by 13 matrices.

With the proposed co-design approach, the solution of the LMI problem (5.53) gets $\alpha = 1145.2$, that implies $\lambda = 0.0296$. The values of η_j are consistently higher for two particular sequences with respect to the others. Indeed, the control related to the sequence $i = \{4, 2, 2\}$ with gains

$$\begin{aligned} K_1^{\{4,2,2\}} &= [0.0285 \quad 0.0333 \quad -0.0715 \quad -0.0333], \\ K_2^{\{4,2,2\}} &= [-0.8215 \quad -0.4668 \quad 0.9070 \quad 0.8719], \\ K_3^{\{4,2,2\}} &= [0.1333 \quad 0.0167 \quad -0.1667 \quad -0.2167] \end{aligned} \quad (5.56)$$

leads to a Schur matrix whose spectral radius is 0.0364. Thus, in this case the periodic sequence cyclic in $\{4, 2, 2\}$ guarantees exponential stability, resulting in a much simpler control. Nevertheless, the state dependent control policies in (5.52) and by using (5.55) provide much better performances, see Figure 5.15 where $x_0 = (1, 1, 0, -1)$.

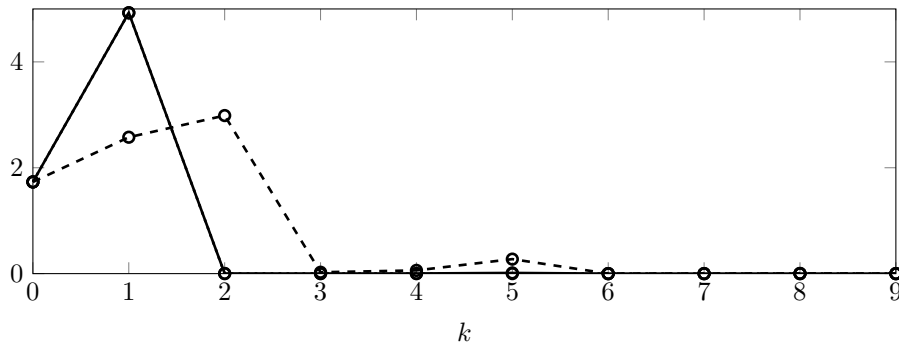

Figure 5.15: Evolutions of $\|x\|_2$ with control (5.52) and min-switching based on (5.55) in solid, periodic control (5.56) in dashed.

Finally, as A_4 is already Schur, with 4 eigenvalues in 0.5, define a new A_4 multiplying it by 2.5. All the eigenvalues of A_4 are now in 1.25. The evolutions of the Euclidean norm of the state, for $x_0 = (1, 1, 0, -1)$, under the obtained controls are depicted in Figure 5.16.

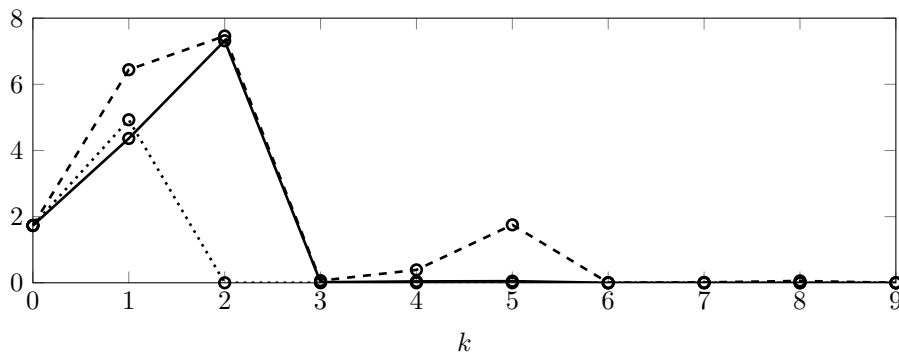

Figure 5.16: Evolutions of $\|x\|_2$ with control (5.52) in solid, periodic control (5.56) in dashed; min-switching based on (5.55) in dotted line.

5.6 Conclusions

This chapter presents several of the results on stability and stabilizability of discrete-time switched linear systems I have been working on in the last years. The proposed methods resort on set-theory and invariance concepts to address the problem of stabilizability, providing an original point of view and leading to novel results. Starting from the geometric approach to stabilizability of switched linear systems and the algorithmic procedure to check the condition, the characterization of the inherent computational complexity of the problem is stated. To go beyond the often unmanageable complexity, alternative novel constructive conditions are presented and other classical ones from the literature recalled to give a complete picture of the different approaches and illustrate their relations, in terms of conservatism and computational complexity.

The practical problem of efficiently testing the stabilizability condition for nontrivial cases has been treated, leading to a method, based on iterative solutions of convex programming problems, that is proved to combine precision with certain numerical advantages. Finally, the problem of control co-design has been addressed, namely the design simultaneous determination of a switching law and a state-feedback rule ensuring closed-loop exponential stability of controlled switched

linear systems. Comparisons with alternative approaches from the literature are given, in terms of performance and computational efficiency.

Finally, it is worth noting that other contributions on this research line have been published, for instance addressing language constrained switched linear systems, that have not be recalled in this manuscript.

Aperiodic sampled-data systems

Contents

6.1 Saturated aperiodically sampled systems	84
6.2 Ellipsoidal sets and quadratic functions	86
6.2.1 Convex conditions for stability and control	86
6.3 Polyhedral sets	90
6.3.1 Outer approximations	92
6.3.2 Inner approximations	94
6.4 Conclusions	100

Motivated by the growing use of embedded controllers in different applications, where a communication protocol is responsible for the transmission of data between computer algorithms, actuators and sensors, the analysis and control design for networked control systems have been addressed in many recent works. In this context, aperiodic sampled-data systems are commonly employed to model the effect of imperfections on the communication channel of networked control systems, like sampling jitters, fluctuations and packet dropouts [Hespanha et al., 2007]. Several methods have been developed to analyse the stability properties of systems subject to a time-varying sampling interval. For instance, in [Fridman, 2010, Liu and Fridman, 2012], a time-delay systems framework is considered and the resulting method is based on Lyapunov-Krasovskii functionals. Similar ideas are considered in [Seuret and Gomes da Silva Jr., 2012], where the looped-functional method is presented. In [Naghshtabrizi et al., 2008, Briat, 2013], the problem is tackled using a hybrid system framework. Numerical tractable criteria can be obtained by using polytopic embeddings for the system transition matrix [Cloosterman et al., 2009, Lombardi et al., 2012], or norm-bounded approximations as in [Fujioka, 2009, Fujioka and Oishi, 2011, Kao and Fujioka, 2013]. In [Fiacchini and Morărescu, 2016] it is shown that the exponential stability of the discrete-time model is equivalent to the existence of a polyhedral Lyapunov function for the system. A survey on the subject can be found in [Hetel et al., 2017].

Few works on aperiodic sampled systems, though, consider the concurrent effects of other sources of complexity related to the interaction of control devices with real systems, as for cyber-physical systems. For instance, due to physical limitations of actuators, the input saturation is ubiquitous in real control problems. It is a source of performance degradation and, in many cases, only local (or regional) stability of the closed-loop system can be ensured, even for linear plants. In the periodic sampled-data case, as the saturation nonlinearity affects only the input, the stability analysis can be carried out by using a discrete-time model (see [Tarbouriech et al., 2011] and references therein) obtained by exact discretization. Nevertheless, for the aperiodic sampled-data case, the problem is more involved and requires a careful analysis of the hybrid behaviour of the system. On this subject, the stability of aperiodic sampled-data systems in the presence of control saturation is addressed [Seuret and Gomes da Silva Jr., 2012, Gomes da Silva Jr. et al., 2016] by resorting on looped-functional approaches and [Fiacchini and Gomes da Silva Jr., 2018], which, based on a set invariance approach, provides LMI-based techniques to compute ellipsoidal estimates of the region of attraction of the origin (RAO) of the closed-loop system, which can be seen as safe regions of operation.

In this chapter, some results are recalled on the problem of providing constructive conditions for local asymptotic stability for aperiodically sampled linear system subject to input saturation, more details can be found in [Fiacchini and Gomes da Silva Jr., 2018, Denardi Huff et al., 2022b, Denardi Huff et al., 2022a, Denardi Huff et al., 2021, Denardi Huff et al., 2022]. The presented methods resort on invariant set properties and local Lyapunov function induced by them, to obtain estimations of the region of attraction of the origin (RAO) besides proofs of local asymptotic stability. As a particular interest is devoted to optimization-based methods and constructive conditions, both ellipsoidal and polyhedral sets are considered, leading to testable LMI conditions and iterative algorithms based on convex optimization. Most of the work presented here is the result of the collaboration with professor **João Gomes da Silva Jr.** and **Daniel Denardi Huff**, whose PhD has been directed on this topic by me and prof. Gomes Da Silva.

6.1 Saturated aperiodically sampled systems

Consider the continuous-time plant described by the following linear model:

$$\dot{x}_p(t) = A_p x_p(t) + B_p u(t) \quad (6.1)$$

where $x_p \in \mathbb{R}^{n_p}$ and $u \in \mathbb{R}^m$ represent the state and the input of the plant, respectively. Matrices A_p and B_p have appropriate dimensions and are supposed to be constant.

Assume that the control signal is constrained in magnitude, i.e.

$$u(t) \in \mathcal{U} = \{u \in \mathbb{R}^m : \|u\|_\infty \leq 1\}.$$

Moreover, a sampled-data control policy is considered, i.e. the control signal is supposed to be computed from the values of system variables at sampling instants $t = t_k$, with $k \in \mathbb{N}$, and kept constant (by means of a zero-order-hold) for all $t \in [t_k, t_{k+1})$. The difference between two successive sampling instants, given by $\delta_k = t_{k+1} - t_k$, is considered to be lower and upper bounded as follows

$$0 < \tau_m \leq \delta_k \leq \tau_M, \quad \forall k \in \mathbb{N}. \quad (6.2)$$

The intersampling time δ_k can be variable, which allows to model an aperiodic sampling strategy. The particular case of periodic sampling corresponds to $\delta_k = \tau_m = \tau_M$ for all $k \in \mathbb{N}$. Thus, given the interval $\Delta = [\tau_m, \tau_M]$ with $0 < \tau_m \leq \tau_M$ and $t_0 = 0$, the set of sequences of admissible sampling instants is defined as follows:

$$\Theta(\Delta) = \left\{ \{t_k\}_{k \in \mathbb{N}} : t_{k+1} = t_k + \delta_k, \delta_k \in \Delta, \forall k \in \mathbb{N} \right\}.$$

From the considerations above, consider the control law given by:

$$u(t) = \text{sat}(K_p x_p(t_k^-) + K_u u(t_k^-)), \quad \forall t \in [t_k, t_{k+1}), \quad (6.3)$$

i.e. the control input to be applied in the interval $[t_k, t_{k+1})$ depends both on the sampled value of the state and the value of the control signal applied in the previous sampling interval $[t_{k-1}, t_k)$. Further on this chapter, the particular case of $K_u = 0$ is considered, as done in the work [Fiacchini and Gomes da Silva Jr., 2018].

Then, for every $\Theta \in \Theta(\Delta)$, the system dynamics can be represented by the following impulsive system:

$$\begin{cases} \dot{x}_p(t) = A_p x_p(t) + B_p u(t), & \forall t \in \mathbb{R}_+ \setminus \Theta, \\ \dot{u}(t) = 0, & \\ \begin{cases} x_p(t) = x_p(t^-) = x_p(t^+), \\ u(t) = u(t^+) = \text{sat}(K_p x_p(t^-) + K_u u(t^-)), \end{cases} & \forall t \in \Theta, \\ x_p(0) = x_{p,0} \in \mathbb{R}^{n_p}, \quad u(0) = \text{sat}(K_p x_{p,0} + K_u u(0^-)) \in \mathbb{R}^m, \end{cases}$$

or, equivalently [Hetel et al., 2013], by

$$\begin{cases} \dot{x}(t) = A_c x(t), & \forall t \in \mathbb{R}_+ \setminus \Theta, \\ x(t) = x(t^+) = A_r x(t^-) + B_r \text{sat}(Kx(t^-)), & \forall t \in \Theta, \\ x(0) = [x_{p,0}^T, \text{sat}(K_p x_{p,0} + K_u u(0^-))^T]^T \in \mathbb{R}^n, \end{cases} \quad (6.4)$$

where $x = [x_p^T, u^T]^T \in \mathbb{R}^n$, with $n = n_p + m$, is the extended system state and $A_c, A_r \in \mathbb{R}^{n \times n}$, $B_r \in \mathbb{R}^{n \times m}$ and $K \in \mathbb{R}^{m \times n}$ are given as follows

$$A_c = \begin{bmatrix} A_p & B_p \\ 0 & 0 \end{bmatrix}, \quad A_r = \begin{bmatrix} I & 0 \\ 0 & 0 \end{bmatrix}, \quad B_r = \begin{bmatrix} 0 \\ I \end{bmatrix}, \quad K = \begin{bmatrix} K_p & K_u \end{bmatrix}. \quad (6.5)$$

Note that, due to the saturation, the closed-loop system (6.4) is nonlinear and, hence, the global stability of the origin cannot be a priori guaranteed. Moreover, if matrix A_p is not Hurwitz, the global stabilization is actually impossible [Sussmann et al., 1994].

In this case, since the analytical characterization of the region of attraction of the origin is in general not possible, the idea is to estimate it through well-defined Lyapunov domains. The considered problem is the stability analysis and stabilization of the system (6.4) in a regional context, i.e. with determination of estimates of the RAO. For this, the dynamics between two consecutive sampling instants is considered.

For a given initial condition and $\Theta \in \Theta(\Delta)$ the evolution of the state x between two successive sampling instants, i.e. for $t \in [t_k, t_{k+1})$, is continuous. Thus, since the continuous-time dynamics is linear, it follows that:

$$x(t) = e^{A_c(t-t_k)} x(t_k), \quad \forall t \in [t_k, t_{k+1}). \quad (6.6)$$

From (6.6) and since $x(t_k^-) \neq x(t_k)$ (due to the impulsive control update, in fact, there is a discontinuity between $x(t_k^-)$ and $x(t_k)$, see (6.4)), the dynamics between two successive sampling instants is given by the following discrete-time equation

$$\begin{aligned} x(t_{k+1}^-) &= e^{A_c(t_{k+1}-t_k)} x(t_k) = e^{A_c(t_{k+1}-t_k)} (A_r x(t_k^-) + B_r \text{sat}(Kx(t_k^-))) \\ &= e^{A_c \delta_k} A_r x(t_k^-) + e^{A_c \delta_k} B_r \text{sat}(Kx(t_k^-)) \end{aligned}$$

where $\delta_k = t_{k+1} - t_k \in \Delta$. Thus, denoting $A(\delta) = e^{A_c \delta} A_r$, $B(\delta) = e^{A_c \delta} B_r$ and $x_k = x(t_k^-)$, the problem of stability and stabilization of the linear impulsive system (6.4) can be addressed by considering the following discrete-time nonlinear parametric uncertain system

$$x_{k+1} \in \{A(\delta)x_k + B(\delta)\text{sat}(Kx_k) : \delta \in \Delta\}. \quad (6.7)$$

The region of attraction of the origin is defined hereafter.

Definition 6.1.1 *Given that the origin of a continuous- (discrete-) time system is asymptotically stable, the region of attraction of the origin (RAO) is the set of all $x \in \mathbb{R}^n$ such that for $x(0) = x$ ($x_0 = x$) it follows that $\lim_{t \rightarrow \infty} x(t) = 0$ ($\lim_{k \rightarrow \infty} x_k = 0$).*

The following bound between two sampling instants holds:

$$\begin{aligned} \|x(t)\| &\leq \|A(t-t_k)\| \|x(t_k)\| + \|B(t-t_k)\| \|\text{sat}(Kx(t_k))\| \\ &\leq (\|A(t-t_k)\| + \|B(t-t_k)\| \|K\|) \|x(t_k)\| \\ &\leq \max_{\tau \in [0, \tau_M]} (\|A(\tau)\| + \|B(\tau)\| \|K\|) \|x(t_k)\| \\ &= C_A \|x_k\|, \quad \forall t \in [t_k, t_{k+1}), \forall k \in \mathbb{N} \end{aligned}$$

Hence, the asymptotic stability of the origin of the discrete-time model (6.21) ensures the asymptotic stability of the continuous-time system (6.1)-(6.3). Then, to obtain estimates of the RAO of the closed-loop system (6.1)-(6.3), it suffices to analyze the behavior of the discrete-time model (6.21), since $x_k \xrightarrow{k \rightarrow \infty} 0$ implies that $x(t) \xrightarrow{t \rightarrow \infty} 0$.

6.2 Ellipsoidal sets and quadratic functions

Consider the partition of the interval $[\tau_m, \tau_M]$ in $J \in \mathbb{N}$ sub-intervals and define the set:

$$\Delta_J = \{d_j = \tau_m + (j-1)\tau_J : j \in \mathbb{N}_J\}, \quad \tau_J = \frac{\tau_M - \tau_m}{J}. \quad (6.8)$$

Since $\delta_k \in [\tau_m, \tau_M]$ and from (6.8), we have that for every δ_k there exist $d_k \in \Delta_J$ and $\tau_k \in [0, \tau_J]$ such that $\delta_k = d_k + \tau_k$ and it follows that:

$$\begin{aligned} A(\delta_k) &= A(d_k + \tau_k) = e^{A_c(d_k + \tau_k)} A_r = e^{A_c \tau_k} A(d_k), \\ B(\delta_k) &= B(d_k + \tau_k) = e^{A_c(d_k + \tau_k)} B_r = e^{A_c \tau_k} B(d_k). \end{aligned}$$

Thus, from (6.7), and defining the following set-valued maps

$$\begin{aligned} \mathcal{F}_j(z) &= \{A(d_j)z + B(d_j)\text{sat}(Kz) : d_j \in \Delta_J\} \subseteq \mathbb{R}^n, \\ \mathcal{G}_j(y) &= \{e^{A_c \tau} y : \tau \in [0, \tau_J]\} \subseteq \mathbb{R}^n, \end{aligned} \quad (6.9)$$

for all $y, z \in \mathbb{R}^n$, then for some $y_k \in \mathcal{F}_j(x_k)$ we have that $x_{k+1} \in \mathcal{G}_j(y_k)$, i.e. the dynamics in (6.7) is equivalently given by the difference inclusion

$$x_{k+1} \in \mathcal{G}_j(\mathcal{F}_j(x_k)). \quad (6.10)$$

The difference inclusion system (6.10) permits to analyze the stability of the system (6.1) in closed loop with (6.3) under aperiodic sampling with inter-sampling time bounded by τ_m and τ_M .

6.2.1 Convex conditions for stability and control

In order to obtain testable conditions, in this section Theorem 1 in [Denardi Huff et al., 2022b] is used. The theorem provides conditions for a positive definite function to be a Lyapunov function for the discrete time system (6.10), then ensuring local asymptotic stability and providing an estimation of the region of attraction for the aperiodically sampled saturated system. The underlying idea is illustrated in Fig. 6.1, that gives a graphical interpretation of the reasoning implied by conditions Theorem 1 in [Denardi Huff et al., 2022b] to guarantee that the function $V(x)$ is decreasing between two sampling instants.

Considering $V(x)$ as a quadratic function allows to express conditions as linear matrix inequalities (LMIs) and therefore to formulate convex optimization problems to determine estimates of the RAO of the closed-loop system and also to design the control feedback gain that maximizes a measure of such an estimation.

To deal with the saturation term, considering the generalized sector condition proposed in [Gomes da Silva Jr. and Tarbouriech, 2005] and using Theorem 1 in [Denardi Huff et al., 2022b] with a quadratic function $V(x) = x^T P x$ with $P = P^T \succ 0$, a constructive condition for stability can be stated.

Theorem 6.2.1 *If there exist a matrix $W = W^T \succ 0$, $W \in \mathbb{R}^{n \times n}$, matrices $R_{d_j} \in \mathbb{R}^{m \times n}$ and diagonal positive definite matrices $S_{d_j} \in \mathbb{R}^{m \times m} \forall d_j \in \Delta_J$, and scalars $\lambda \in (0, 1)$ and $\alpha = -\ln(\lambda) / \tau_J > \max\{2\sigma_{\max}(A_c), 0\}$ satisfying the following LMIs*

$$\begin{bmatrix} \lambda W & R_{d_j}^T & W A^T(d_j) + W K^T B^T(d_j) \\ * & 2S_{d_j} & S_{d_j} B^T(d_j) \\ * & * & W \end{bmatrix} \succeq 0, \quad \forall j \in \mathbb{N}_J \quad (6.11)$$

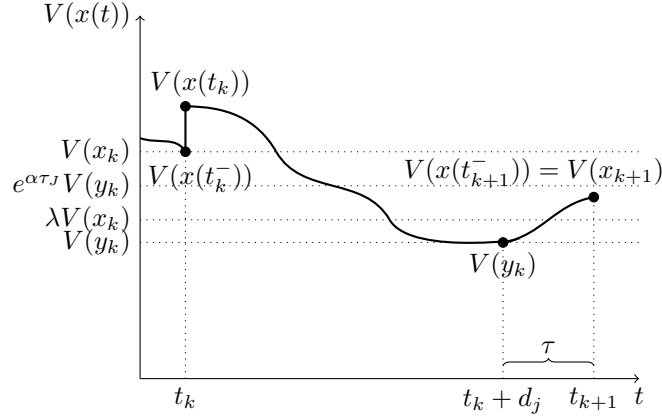
Figure 6.1: Behavior of $V(x(t))$.

$$\begin{bmatrix} W & WK_{(i)}^T - R_{d_j(i)}^T \\ \star & 1 \end{bmatrix} \succeq 0, \forall j \in \mathbb{N}_J, \forall i \in \mathbb{N}_m \quad (6.12)$$

$$WA_c^T + A_c W - \alpha W < 0 \quad (6.13)$$

then, for all $x(0^-) = x_0 \in \mathcal{E}(W^{-1}, 1) = \{x \in \mathbb{R}^n ; x^T W^{-1} x \leq 1\}$, it follows that the corresponding trajectory of the sampled-data system (6.1)-(6.3), with δ_k satisfying (6.2), converges asymptotically to the origin.

Clearly the periodic sampling case (i.e. when $\tau_m = \tau_M$) is obtained as a particular case with the set Δ_J as $\Delta_J = \{\tau_m\} = \{\tau_M\}$. In this case condition (6.13) can be discarded and the LMIs (6.11) and (6.12) turn out to be the classical LMIs used for linear discrete-time systems subject to input saturations when the generalized sector condition is used to deal with the saturation term, see [Tarbouriech et al., 2011, Section 3.6].

Given the bounds τ_m and τ_M on δ_k , the conditions of Theorem 6.2.1 can be used to compute regions of guaranteed stability for the sampled-data closed-loop system, i.e. estimates of the region of attraction of the origin. Actually, provided $x_0 \in \mathcal{E}(P, 1)$ with $P = W^{-1}$, conditions of Theorem 6.2.1 guarantee that the corresponding trajectory converges asymptotically to the origin.

The region $\mathcal{E}(P, 1)$, though, is defined in the space of $x = [x_p^T \ u^T]^T$, the aim is to define the estimate of the RAO in the x_p -hyperplane, considering the initial value of $u(0^-)$ as a free parameter to be determined. In fact, if the extended state $x_0 = [x_{p,0}^T \ u(0^-)^T]^T$ is in $\mathcal{E}(W^{-1}, 1)$, with W satisfying the LMI conditions given in Theorem 6.2.1, then $x_k \in \mathcal{E}(W^{-1}, 1)$ for all $k \in \mathbb{N}$ and converges asymptotically to the origin. Thus, the set of states $x_{p,0}$, for which an input $u(0^-)$ can be defined such that the resulting $x_0 = [x_{p,0}^T \ u(0^-)^T]^T$ belongs to $\mathcal{E}(W^{-1}, 1)$ is an estimate of the RAO.

Defining the following partitions of P and $W = P^{-1}$:

$$P = \begin{bmatrix} P_{11} & P_{12} \\ P_{21} & P_{22} \end{bmatrix}, \quad W = \begin{bmatrix} W_{11} & W_{12} \\ W_{21} & W_{22} \end{bmatrix} \quad (6.14)$$

where $P_{11}, W_{11} \in \mathbb{R}^{n_p \times n_p}$ and $P_{22}, W_{22} \in \mathbb{R}^{m \times m}$ and

$$u(0^-) = -P_{22}^{-1} P_{12}^T x_{p,0} \quad (6.15)$$

the set $\mathcal{E}(P_{11} - P_{12}P_{22}^{-1}P_{21}, 1) \subseteq \mathbb{R}^{n_p}$ results to be an estimate of the RAO. In fact, if $x_{p,0} \in \mathcal{E}(P_{11} - P_{12}P_{22}^{-1}P_{21}, 1)$ and $u(0^-)$ is as in (6.15) then

$$\begin{aligned} x_0^T P x_0 &= x_{p,0}^T P_{11} x_{p,0} + 2x_{p,0}^T P_{12} u(0^-) + u(0^-)^T P_{22} u(0^-) \\ &= x_{p,0}^T P_{11} x_{p,0} - x_{p,0}^T P_{12} P_{22}^{-1} P_{12}^T x_{p,0} \leq 1 \end{aligned}$$

which means that $x_0 \in \mathcal{E}(P, 1) = \mathcal{E}(W^{-1}, 1)$.

On the other hand, it can be checked that

$$P^{-1} = W = \begin{bmatrix} Q^{-1} & -Q^{-1}P_{12}P_{22}^{-1} \\ \star & P_{22}^{-1} + P_{22}^{-1}P_{21}Q^{-1}P_{12}P_{22}^{-1} \end{bmatrix},$$

where

$$Q = P_{11} - P_{12}P_{22}^{-1}P_{21}$$

is the Schur complement of P_{22} with respect to P . That is, we have that $\mathcal{E}(P_{11} - P_{12}P_{22}^{-1}P_{21}, 1) = \mathcal{E}(W_{11}^{-1}, 1)$.

Thus, the idea is to maximize this “safe” set of plant initial states given by $\mathcal{E}(W_{11}^{-1}, 1)$, considering some size criterion. For instance, the maximization of the minor axis of the set can be considered through the following optimization problem:

$$\begin{aligned} &\max_{W, R_d, S_d, \varepsilon} \quad \varepsilon \\ &\text{subject to:} \\ &\quad (6.11), (6.12), (6.13), \\ &\quad W_{11} - \varepsilon I \succ 0. \end{aligned} \tag{6.16}$$

Other size criteria, such as the volume maximization or the maximization of the set in certain directions can also be easily considered, see [Tarbouriech et al., 2011]. Note that problem (6.16) is associated to a given partition of the interval $[\tau_m, \tau_M]$. In order to find a suitable partition, an algorithm can be found in [Denardi Huff et al., 2022b] is proposed, that ensures finite termination and provides a solution if a quadratic Lyapunov function with exponential decreasing exists.

The LMI problem (6.16) can be easily adapted to design a feedback gain K that maximizes the set $\mathcal{E}(W_{11}^{-1}, 1)$. It suffices to use the following change of variables:

$$Z = KW. \tag{6.17}$$

As discussed in [Gomes da Silva Jr. and Tarbouriech, 2001] for the periodic sampling case, the control law computed from (6.16), without any performance additional constraint, can lead to a large region of stability, but will in general result in a very slow behaviour. Moreover, it is not fair to demand the same performance level when the control is saturated, since the behaviour is in open-loop in this case. Hence, an effective way of balancing performance and size of the region of attraction is to force some performance constraint only when the system operates in the linearity control region. For instance, we can add to (6.16) the following LMIs:

$$\begin{bmatrix} \gamma\lambda W & WA^T(d_j) + Z^T B^T(d_j) \\ \star & W \end{bmatrix} \succeq 0, \quad \forall j \in \mathbb{N}_J \tag{6.18}$$

where $0 < \gamma < 1$ is a parameter fixed *a priori*. Note that constraints (6.18) impose that $V(x_{k+1}) < \gamma V(x_k)$ when the control is not saturated, i.e. it ensures an exponential decay convergence rate for the operation of the system in the linearity region.

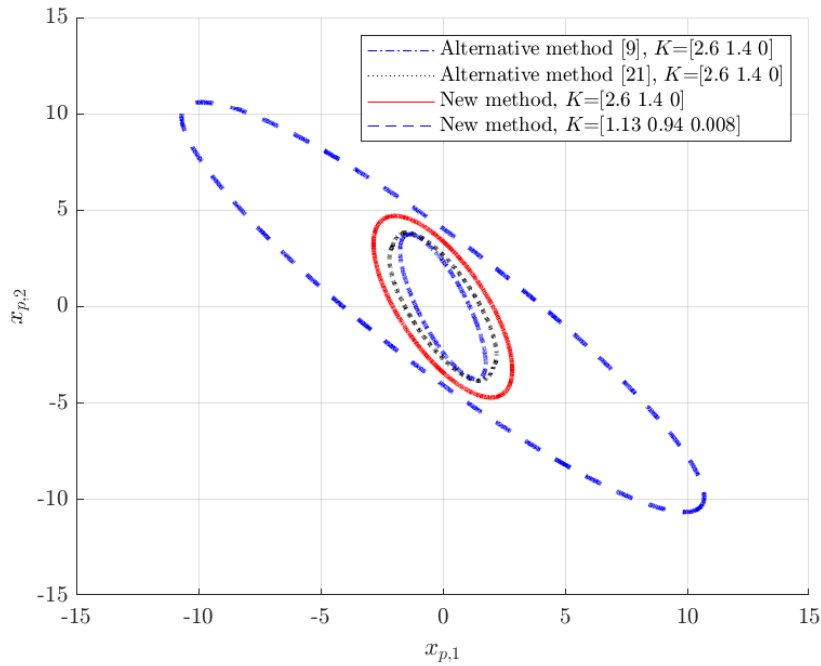

Figure 6.2: Estimates of the region of attraction of the origin.

6.2.1.1 Example

Consider system (6.1)-(6.3) with the following matrices [Tarbouriech et al., 2011]:

$$A_p = \begin{bmatrix} 0 & 1 \\ 1 & 0 \end{bmatrix}, \quad B_p = \begin{bmatrix} 0 \\ -5 \end{bmatrix}, \quad K_p = [2.6 \quad 1.4], \quad K_u = [0],$$

with the interval of admissible intersampling times given by $\Delta = [0.05, 0.1]$. In this case, for $\lambda = 0.98$ a feasible solution for the optimization problem (6.16) is obtained with a partition of Δ in 30 sub-intervals (i.e. $J = 30$), leading to:

$$W^{-1} = \begin{bmatrix} 0.2580 & 0.1012 & -0.0204 \\ 0.1012 & 0.0868 & -0.0019 \\ -0.0204 & -0.0019 & 0.0211 \end{bmatrix}, \quad \varepsilon = 3.4785.$$

Considering now the stabilization problem described above with $\gamma = 0.9$ and the same values for λ and J , we obtain

$$K = [1.13 \quad 0.94 \quad 0.008]. \quad (6.19)$$

and the region of attraction estimate given by

$$W^{-1} = \begin{bmatrix} 0.0612 & 0.0562 & -0.0037 \\ 0.0562 & 0.0608 & -0.0012 \\ -0.0037 & -0.0012 & 0.0127 \end{bmatrix}, \quad \varepsilon = 8.60.$$

Figure 6.2 shows on the left the resulting estimates of the region of attraction of the origin. The ellipsoid obtained with the designed K is indeed larger than the original one, as expected.

For comparison purposes, the figure shows the estimate of the RAO obtained with the method proposed in [Fiacchini and Gomes da Silva Jr., 2018] (denoted by [21] in the figure legend), which corresponds to the sublevel set of a piecewise quadratic function, and with the looped-functional approach proposed in [Seuret and Gomes da Silva Jr., 2012] (denoted by [9] in the figure legend), which is an ellipsoidal domain. As it can be observed, the method proposed here resulted in a larger domain for the same value of K .

6.3 Polyhedral sets

Consider now the continuous-time system (6.1) with aperiodic sampling and linear saturated stabilizing state feedback at the time instants t_k , with $k \in \mathbb{N}$, given by

$$u(t) = \text{sat}(Kx_p(t_k)), \quad \forall t \in [t_k, t_{k+1}), \quad (6.20)$$

meaning that the feedback is function of the sampled state only, not of the previous value of the input as for the method illustrated above.

Introducing, if necessary, the extended state $x = [x_p^T, u^T]^T$ or simply $x = x_p$, and denoting $x_k = x(t_k)$, it follows, from the analytical solution of (6.1) and considering (6.20), that the dynamics between two successive sampling instants can be described by the following difference inclusion:

$$\begin{aligned} x_{k+1} &\in \{A(\delta)x_k + B(\delta)\text{sat}(K(\delta)x_k) : \delta \in \Delta\} \\ &= \{\mathcal{F}(x_k, \delta) : \delta \in \Delta\} \\ &= \mathcal{F}(x_k, \Delta) \end{aligned} \quad (6.21)$$

where $\Delta = [\tau_m, \tau_M]$ and the expression of $A(\delta)$, $B(\delta)$ and $K(\delta)$ would depend on the modelling framework, as it will be illustrated afterward.

Given the general nonlinear difference inclusion (6.21), it can be defined the one-step set for this system as follows.

Definition 6.3.1 *Given $\Omega \subseteq \mathbb{R}^n$, the one-step set $P(\Omega)$ w.r.t. (6.21) is given by*

$$P(\Omega) = \{x \in \mathbb{R}^n : \mathcal{F}(x, \Delta) \subseteq \Omega\}.$$

Notice that $P(\Omega)$ is the set of all $x_k \in \mathbb{R}^n$ such that x_{k+1} will belong to Ω for all possible values of the intersampling time. The set Ω is an invariant set for (6.21) if and only if $\Omega \subseteq P(\Omega)$ [Blanchini and Miani, 2008]. Given an invariant C-set Ω_0 for (6.21) that belongs to its RAO, the increasing sequence of nested sets

$$\Omega_{i+1} = P(\Omega_i), \quad i \in \mathbb{N}, \quad (6.22)$$

gives approximations of increasing accuracy of the RAO of the discrete-time system (6.21), denoted by Γ_d . Moreover, the one-step set can also be used to compute a decreasing sequence converging to Γ_d from the outside.

The computation of such sets, though, is in general not possible in practice. In particular, $P(\Omega)$ may be nonconvex even if Ω is a C-set because of the saturation function. The concepts of SNS (saturated and nonsaturated) invariance and SNS RAO, originally presented in [Alamo et al., 2006], are then used to obtain convex approximation of the one-step sets and thus inner estimation of the RAO for the saturated aperiodically sampled system.

6.3.0.1 SNS contractive sets

The SNS system that corresponds to (6.21) has, besides δ , an additional parameter $S \in \mathcal{S} = 2^{\mathbb{N}_m}$ which is related to the saturation function and indicates which components of this function are activated or not. Its interest lies in the fact that the SNS model is less conservative than classical polytopic embeddings of the saturation function [Alamo et al., 2006, Section 5],[Tarbouriech et al., 2011, Chapter 1].

Define $\text{sat}_S : \mathbb{R}^m \rightarrow \mathbb{R}^m$ as

$$\text{sat}_S(z) = \sum_{i \in S^c} e_i z_{(i)} + \sum_{i \in S} e_i \text{sat}(z_{(i)}), \quad (6.23)$$

where $S \in \mathcal{S}$ and $S^c = \mathbb{N}_m \setminus S$. Define also

$$\mathcal{F}_{SNS}(x_k, \delta, S) = A(\delta)x_k + B(\delta)\text{sat}_S(K(\delta)x_k)$$

The SNS system related to (6.21) is then given by

$$x_{k+1} \in \mathcal{F}_{SNS}(x_k, \Delta, \mathcal{S}) = \{\mathcal{F}_{SNS}(x_k, \delta, S) : \delta \in \Delta, S \in \mathcal{S}\}. \quad (6.24)$$

Notice that the difference inclusion above takes into account all 2^m possible combinations of saturated/nonsaturated inputs given by $S \in \mathcal{S} = 2^{\mathbb{N}_m}$ simultaneously.

Definition 6.3.2 *A SNS invariant (contractive) set for system (6.21) is an invariant (contractive) set for (6.24). The SNS Region of Attraction of the Origin (SNS RAO) of system (6.21), denoted by Γ_{SNS} , is the RAO of (6.24).*

The dynamics of (6.24) embeds the one of (6.21), i.e.

$$\mathcal{F}(x_k, \Delta) \subseteq \mathcal{F}_{SNS}(x_k, \Delta, \mathcal{S}),$$

therefore, $\Gamma_{SNS} \subseteq \Gamma_d$. This fact will be exploited by the method presented here. Actually, to obtain a numerical tractable procedure, the idea is to compute polyhedral estimates of Γ_d through the computation of estimates of Γ_{SNS} .

As in Definition 6.3.1, the one-step set related to (6.24) is given by

$$Q(\Omega) = \{x \in \mathbb{R}^n : \mathcal{F}_{SNS}(x, \Delta, \mathcal{S}) \subseteq \Omega\}.$$

The relevant feature of the one-step set is that it is a convex inner approximation of the one-step set for the original system (6.21) and then it can be used, analogously to (6.22), to design an iterative procedure to compute SNS invariant approximations of the ROA:

$$\Omega_{i+1} = Q(\Omega_i), \quad i \in \mathbb{N}. \quad (6.25)$$

Starting for instance from an initial SNS invariant C-set, the sequence $\{\Omega_i\}_{i \in \mathbb{N}}$ can be proved to be an increasing sequence of nested convex SNS invariant sets converging to the SNS region of attraction of the origin Γ_{SNS} . Moreover, since $\Gamma_{SNS} \subseteq \Gamma_d$, then the iteration provides a sequence of inner approximations of the original saturated aperiodically sampled system.

Unfortunately, as discussed in [Fiacchini and Morărescu, 2016], even for the linear case under aperiodic sampling, the one-step set $Q(\Omega)$ is in general not polyhedral even if Ω is a polytope. This is due to the dependence of the discrete-time model (6.24) on an uncertain matrix exponential term $e^{A_c \delta}$, where the value of δ varies within an interval Δ . A common approach to deal with this term consists in obtaining convex embeddings for it, which can be polytopic [Cloosterman et al., 2009, Lombardi et al., 2012] or norm-bounded ones [Fujioka, 2009, Fujioka and Oishi, 2011, Kao and Fujioka, 2013].

In order to obtain numerically tractable conditions for the stability analysis, it is convenient to adopt a different strategy as in [Fiacchini and Morărescu, 2016, Denardi Huff et al., 2022b, Denardi Huff et al., 2022a], which consists in considering the grid of the interval Δ defined in (6.8) and introducing

$$Q_J(\Omega) = \{x \in \mathbb{R}^n : \mathcal{F}_{SNS}(x, \Delta_J, \mathcal{S}) \subseteq \Omega\} \quad (6.26)$$

for $\Omega \subseteq \mathbb{R}^n$ and $J \in \mathbb{N}_+$. Notice that $Q_J(\Omega)$ takes into account only the finite subset Δ_J of possible values for the intersampling time δ_k , leading to polytopic preimages for polytopic sets Ω . So $Q(\Omega) \subseteq Q_J(\Omega)$ but these sets are different in general.

6.3.1 Outer approximations

Consider first the state $x = x_p$ leading to a discrete-time dynamics (6.21) with $A(\delta) = e^{A_p \delta}$, $B(\delta) = \int_0^\delta e^{A_p s} ds B_p$ and $K(\delta) = K$, as given in [Denardi Huff et al., 2022a]. Note that, differently from the model used in the previous section, here the discrete-time system does not concern the extended state formed by the plant state and the previous constant value of the input. Thus, no discontinuity in the state occurs in this framework.

The proposed stability analysis method, leading to convex outer approximations of the SNS ROA, convergent to it, can be divided in two steps. The first one consists in finding a contractive polyhedral C-set Ω for the dynamics

$$x_{k+1} \in F_{SNS}(x_k, \Delta_J, \mathcal{S}) \quad (6.27)$$

where Δ_J as in (6.8) with $J \in \mathbb{N}$. The map in (6.27) considers only a finite subset Δ_J of the interval Δ and thus (6.27) is embedded by (6.24), i.e. $F_{SNS}(x_k, \Delta_J, \mathcal{S}) \subseteq F_{SNS}(x_k, \Delta, \mathcal{S})$.

The definition of one-step set for (6.27) is given below.

Definition 6.3.3 *Given $J \in \mathbb{N}$ and $\Omega \subseteq \mathbb{R}^n$, the one-step set $Q_J(\Omega)$ of Ω is*

$$Q_J(\Omega) = \{x \in \mathbb{R}^n : F_{SNS}(x, \Delta_J, \mathcal{S}) \subseteq \Omega\}. \quad (6.28)$$

Then a C-set Ω is λ -contractive for (6.27) if $\Omega \subseteq Q_J(\lambda\Omega)$. The following lemma, based on results from [Alamo et al., 2006], provides a polyhedral characterization of $Q_J(\Omega)$ when Ω is a polyhedron.

Lemma 6.3.1 *Let Ω be a polyhedron, where $\Omega = \mathcal{P}(H, h)$ is its H -representation. Then*

$$Q_J(\Omega) = \bigcap_{\delta \in \Delta_J} \bigcap_{S \in \mathcal{S}} \left\{ x \in \mathbb{R}^n : H \left(A(\delta) + \sum_{i \in S^c} B^{(i)}(\delta) K_{(i)} \right) x - \sum_{i \in S} |HB^{(i)}(\delta)| \leq h \right\}. \quad (6.29)$$

The following theorem, inspired by [Blanchini, 1994, Theorem 3.1], introduces the recursion used to find the maximal λ -contractive C-set for (6.27) in a given C-set Ω_0 . Unlike [Blanchini, 1994, Theorem 3.1] though, valid only for linear systems, this result applies to the nonlinear case of SNS systems.

Theorem 6.3.1 *Given $J \in \mathbb{N}$, consider the sequence of sets*

$$\Omega_{i+1} = Q_J(\lambda\Omega_i) \cap \Omega_0, \quad \forall i \in \mathbb{N}, \quad (6.30)$$

where Ω_0 is a polyhedral C-set and $0 < \lambda < 1$. The following properties hold:

1. Ω_i is a polyhedral C-set for all $i \in \mathbb{N}$.
2. $\Omega_{i+1} \subseteq \Omega_i$ for all $i \in \mathbb{N}$.

3. If a λ -contractive C-set for (6.27) $\Omega' \subseteq \Omega_0$ exists, then

$$\underline{\Omega}_{\lambda,J} = \bigcap_{i \in \mathbb{N}} \Omega_i \quad (6.31)$$

is the maximal λ -contractive C-set for (6.27) in Ω_0 .

In general, the set $\underline{\Omega}_{\lambda,J}$ might be not obtainable in a finite number of iterations by an algorithm (and in general it is not polyhedral). In this case, though, it is proved in [Denardi Huff et al., 2022a] that, under mild assumptions, for all $\lambda^* \in (\lambda, 1)$ there exists $i^* \in \mathbb{N}$ such that the set $\Omega = \lambda/\lambda^* \Omega_{i^*}$, obtained by iterating (6.30) a finite number i^* of times, is a λ^* -contractive polyhedral C-set for (6.27).

The second step of the method consists in verifying if the contractive set Ω found for (6.27) is also contractive for the dynamics (6.24), which takes into account all possible values for $\delta_k \in \Delta$ and not only the finite set Δ_J . If this is true, in fact, the set Ω is an estimate of the RAO of (6.21) and, consequently, of the RAO of the closed-loop system (6.1)-(6.20).

Using the result [Denardi Huff et al., 2022a, Lemma 5], it follows that

$$\begin{aligned} F_{SNS}(x, d + \tau, S) &= \begin{bmatrix} A(d + \tau) & B(d + \tau) \end{bmatrix} \begin{bmatrix} x \\ \text{sat}_S(Kx) \end{bmatrix} \\ &= \left(\begin{bmatrix} A(d) & B(d) \end{bmatrix} + \Phi(\tau) e^{A_p d} \begin{bmatrix} A_p & B_p \end{bmatrix} \right) \begin{bmatrix} x \\ \text{sat}_S(Kx) \end{bmatrix} \\ &= F_{SNS}(x, d, S) + \underbrace{\Phi(\tau) e^{A_p d} \begin{bmatrix} A_p & B_p \end{bmatrix}}_{=N(d)} \begin{bmatrix} x \\ \text{sat}_S(Kx) \end{bmatrix}. \end{aligned} \quad (6.32)$$

Defining the logarithmic norm of A_p associated with the 2-norm [Van Loan, 1977]: $\mu(A_p) = \sigma_{\max} \left(\frac{A_p + A_p^T}{2} \right)$, that can be negative, the following theorem is posed.

Theorem 6.3.2 Consider $J \in \mathbb{N}$ and a λ^* -contractive polyhedral C-set Ω for the dynamics (6.27). If the constant

$$\bar{c}(\Omega, J) = c_1(J) c_2 c_3(\Omega) c_4(\Omega), \quad (6.33)$$

where

$$c_1(J) = \begin{cases} \frac{e^{\mu(A_p)\tau_J} - 1}{\mu(A_p)} & \text{if } \mu(A_p) \neq 0 \\ \tau_J & \text{if } \mu(A_p) = 0 \end{cases} \quad (6.34)$$

$$c_2 = \max(e^{\mu(A_p)\tau_m}, e^{\mu(A_p)\tau_M}) \sqrt{\|A_p\|^2 + \|B_p\|^2} \quad (6.35)$$

$$c_3(\Omega) = \max_{x \in \Omega} \left\| \begin{bmatrix} I \\ K \end{bmatrix} x \right\| \quad (6.36)$$

$$c_4(\Omega) = \Psi_\Omega(\mathcal{B}), \quad \mathcal{B} = \{x \in \mathbb{R}^n : \|x\| \leq 1\}, \quad (6.37)$$

is such that

$$\nu(\Omega, J) = \lambda^* + \bar{c}(\Omega, J) < 1, \quad (6.38)$$

then Ω is $\nu(\Omega, J)$ -contractive for the dynamics (6.24).

In practice, the theorem above provides a constructive condition for the polyhedron Ω contractive for (6.27) to be contractive also (6.24), although with different decreasing rate. An algorithm is proposed in [Denardi Huff et al., 2022a] to obtain a $\nu(\Omega, J)$ -contractive polyhedral C-set Ω for (6.24), and can be therefore used as an estimate of the RAO of system (6.1) with control (6.20).

6.3.2 Inner approximations

Consider now the extended state dynamics with feedback of the plant state only, that is the linear saturated stabilizing state feedback, is

$$u(t_k) = \text{sat}(K_p x_p(t_k^-)), \quad \forall k \in \mathbb{N} \quad (6.39)$$

and the system, whose state is $x = [x_p^T, u^T]^T$, is given by given by (6.4) with (6.5) and $K_u = 0$. Defining $x_k = x(t_k^+)$, the dynamics are given by (6.21) with $A(\delta) = A_r e^{A_c \delta}$, $B(\delta) = B_r$ and $K(\delta) = K e^{A_c \delta}$, in fact:

$$x_{k+1} \in \{A(\delta)x_k + B_r \text{sat}(K(\delta)x_k) : \delta \in \Delta\} = \{\mathcal{F}(x_k, \delta) : \delta \in \Delta\} = \mathcal{F}(x_k, \Delta). \quad (6.40)$$

Also in this framework, since $\|x(t)\| \leq \max_{\delta \in [0, \tau_M]} \|e^{A_c \delta}\| \|x_k\|$, for all $t \in [t_k, t_{k+1})$, then the stability of the origin of the closed-loop system (6.4) is implied by the one of the discrete-time system (6.40), see [Fiacchini and Gomes da Silva Jr., 2018]. Moreover, the RAO of (6.40) Γ_d , coincides with the RAO of (6.4), denoted Γ_c , i.e. $\Gamma_d = \Gamma_c$.

To obtain estimates of the RAO of (6.40) through the computation of polyhedral estimates of the SNS RAO, it is not possible, as explained before, to simply replace the operator $Q(\cdot)$ by $Q_J(\cdot)$ in the recursion (6.25) since $Q_J(\cdot)$ does not take into account all possible values of δ_k . Suppose that the number of partitions J of Δ is high enough for $Q_J(\cdot)$ to be a C-set (such technical conditions are expressed in terms of $J \leq J^*$ with J^* given in [Denardi Huff et al., 2022]).

The objective is now to construct, in a numerically tractable way, an increasing sequence $\{\Omega_i\}_{i \in \mathbb{N}}$ of SNS λ_i -contractive polyhedral C-sets for (6.40) using an initial SNS λ_0 -contractive polyhedral C-set Ω_0 . From the contractivity property, it follows that these sets are included in $\Gamma_{SNS} \subseteq \Gamma_d = \Gamma_c$, being therefore estimates of Γ_c .

In order to construct the sequence $\{\Omega_i\}_{i \in \mathbb{N}}$, the operator $Q(\Omega)$ in (6.25) will be replaced by the set $\hat{Q}_J(\Omega)$ defined below in spite of by $Q_J(\Omega)$, that would not ensure contractivity. The main difference is that $\hat{Q}_J(\Omega)$ corresponds to an inner approximation of $Q(\Omega)$ while $Q_J(\Omega)$ corresponds to an outer approximation of $Q(\Omega)$. The set $\hat{Q}_J(\Omega)$ will be obtained by scaling down $Q_J(\Omega)$.

Definition 6.3.4 *Given the polyhedral C-set $\Omega \subset \mathbb{R}^n$, $J \geq J^*$ and the H -representation¹ $Q_J(\Omega) = \mathcal{P}(H, \mathbf{1})$, $H \in \mathbb{R}^{n_h \times n}$,*

$$\beta^J(\Omega) = \inf_{T, \beta} \beta \text{ s.t. } \begin{cases} HA_c = TH \\ T\mathbf{1} \leq \beta\mathbf{1} \\ T_{(i,j)} \succeq 0, \quad \forall i \neq j \end{cases} \quad (6.41)$$

$$\alpha^J(\Omega) = \max\{1, e^{\beta^J(\Omega)\tau_J}\} \quad (6.42)$$

$$\hat{Q}_J(\Omega) = Q_J(\Omega) / \alpha^J(\Omega) \quad (6.43)$$

where $T \in \mathbb{R}^{n_h \times n_h}$, $\beta \in \mathbb{R}$, A_c is defined in (6.5) and τ_J in (6.8).

It can be proved, see [Denardi Huff et al., 2022], that the constraints in (6.41) are feasible for some $\beta \in \mathbb{R}$, possibly greater than one, if and only if the polyhedral C-set $Q_J(\Omega) = \mathcal{P}(H, \mathbf{1})$ is β -invariant for $\dot{x}(t) = A_c x(t)$, that means contractive for the linear continuous-time system with contraction β possibly greater than 1. Then, $\beta^J(\Omega)$ is the smallest number β such that $Q_J(\Omega)$ is β -invariant for this system.

¹ $Q_J(\Omega)$ is a polyhedral C-set under mild assumptions and it can be assumed without loss of generality that $h = \mathbf{1}$ since $0 \in \text{int}(Q_J(\Omega))$.

The theorem below, proved in [Denardi Huff et al., 2022], guarantees that the inclusion

$$\hat{Q}_J(\Omega) = Q_J(\Omega)/\alpha^J(\Omega) \subseteq Q(\Omega)$$

holds. The motivation for choosing the scale factor $\alpha^J(\Omega)$ is clear from the proof of this theorem, see the paper cited above. The number $\alpha^J(\Omega)$ is related to the possible expansion of the set $\hat{Q}_J(\Omega)$ along the trajectories of continuous-time system in a time interval $[0, \tau] \subseteq [0, \tau_J]$.

Theorem 6.3.3 *Given a polyhedral C-set $\Omega \subset \mathbb{R}^n$ and $J \geq J^*$, it follows that*

$$\hat{Q}_J(\Omega) \subseteq Q(\Omega) \tag{6.44}$$

As recalled earlier, the conditions on the parameter J^* ensuring the preimage to be polyhedral are given in the paper.

The second result on which the iterative procedure is based, is the fact that for J big enough, the preimage $Q_J(\Omega)$ contains Ω in its interior, provided the set Ω is an SNS contractive set, see [Denardi Huff et al., 2022].

Theorem 6.3.4 *Given a SNS contractive polyhedral C-set $\Omega \subset \mathbb{R}^n$ for (6.40), there exists $\bar{J} \in \mathbb{N}$, $\bar{J} \geq J^*$, such that*

$$\Omega \subset \text{int}(\hat{Q}_J(\Omega)), \quad \forall J \geq \bar{J} \tag{6.45}$$

Figure 6.3 presents a geometrical interpretation of Theorems 6.3.3 and 6.3.4. As the value of J increases, the set $\hat{Q}_J(\Omega)$ converges to $Q(\Omega)$ from the inside, while $Q_J(\Omega)$ converges to $Q(\Omega)$ from the outside. Therefore, for J sufficiently large, $\Omega \subset \text{int}(\hat{Q}_J(\Omega))$ holds, that is the condition for $Q_J(\Omega)$ to be an SNS invariant provided Ω is it too, see Figure 6.3, right. The complexity of sets $Q_J(\Omega)$ and $\hat{Q}_J(\Omega)$, though, increases in principle as J grows, as reasonable.

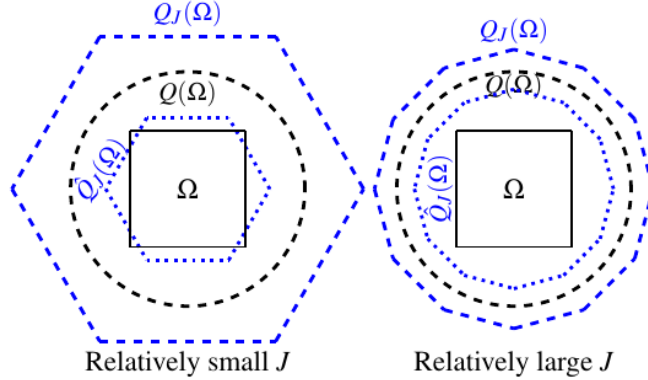

Figure 6.3: Illustration of the relation between the sets $\hat{Q}_J(\Omega)$, $Q_J(\Omega)$ and $Q(\Omega)$.

The properties above are used in Algorithm 5, which applies them recursively to provide an increasing sequence of estimates of the (SNS) RAO of the saturated aperiodically sampled system. The MPT toolbox [Herceg et al., 2013], which has functions to manipulate polyhedral sets, can be used. The initial SNS contractive polyhedral C-set $\Omega_0 \subset \mathbb{R}^n$ for (6.40) can be obtained by computing a contractive set for the linear aperiodic-sampled system using the method proposed in [Fiacchini and Morărescu, 2016] and the region of linearity $\mathcal{L} = \{x \in \mathbb{R}^n : K(\delta)x \in \mathcal{U}, \forall \delta \in \Delta\}$ of (6.40).

Algorithm 5 Increasing sequence of estimates of $\Gamma_{SNS} \subseteq \Gamma_c$

Input: Initial SNS contractive polyhedral C-set $\Omega_0 \subset \mathbb{R}^n$ for (6.40), $\bar{i} \in \mathbb{N}$, $J_0 \geq J^*$

$i \leftarrow 0$, $J \leftarrow J_0$

while $i < \bar{i}$ **do**

 Compute $\hat{Q}_J(\Omega_i)$ according to Definition 6.3.4

if

$$\Omega_i \subset \text{int}(\hat{Q}_J(\Omega_i)) \quad (6.46)$$

then

$$\Omega_{i+1} = \hat{Q}_J(\Omega_i), \quad J_{i+1} = J \quad (6.47)$$

$i \leftarrow i + 1$

 Increment J

Output: Estimate of the RAO: $\Omega_{\bar{i}}$

Algorithm 5, detailed in [Denardi Huff et al., 2022], generates a sequence $\{\Omega_i\}_{i=0}^{\bar{i}}$ of polyhedral C-sets and a corresponding strictly increasing sequence of integers $\{J_i\}_{i=1}^{\bar{i}}$ that satisfy for all i :

$$\begin{aligned} \Omega_{i+1} &\subseteq Q(\Omega_i) && \text{(from (6.47) and Theorem 6.3.3)} \\ \Omega_i &\subset \text{int}(\Omega_{i+1}) && \text{(from (6.46) and (6.47))} \\ \Omega_{i+1} &\text{ is SNS } \lambda_{i+1}\text{-contractive for (6.40)} && \text{(from (6.46) and (6.47))} \\ \Omega_{i+1} &\subseteq \Gamma_{SNS} \subseteq \Gamma_c && \text{(from (6.48a))} \\ \Omega_{i+1} &= \hat{Q}_{J_{i+1}}(\Omega_i) && \text{(from (6.47))} \end{aligned} \quad (6.48a)$$

Theorem 6.3.4 guarantees that the test (6.46) will eventually be true since J is always incremented, thus the algorithm has a finite execution time. Moreover, the estimate $\Omega_{\bar{i}}$ of the RAO is related to $x_0 = [x_p(0)^T, u(0)^T]^T$ but $x_p(0)$ and $u(0)$ are actually coupled by the relation $u(0) = \text{sat}(K_p x_p(0))$. Hence, considering the H -representation $\Omega_{\bar{i}} = \mathcal{P}(H, h) = \{x \in \mathbb{R}^n : Hx \leq h\}$, the “safe” set of plant initial states corresponds to the union of 3^m polytopes [Gomes da Silva Jr. and Tarbouriech, 1999]:

$$\Omega_{\bar{i}, x_p} = \left\{ x_p \in \mathbb{R}^{n_p} : H \begin{bmatrix} x_p \\ \text{sat}(K_p x_p) \end{bmatrix} \leq h \right\}. \quad (6.49)$$

Notice that the bigger \bar{i} is, the bigger will be the estimate $\Omega_{\bar{i}, x_p}$ of the RAO of the system. However, the polytopes Ω_i computed by Algorithm 5 tend to become more complex at each iteration. Then, the execution time of the computer code also grows at each iteration and, in practice, the maximum number of iterations \bar{i} cannot be arbitrarily large. The method of [Denardi Huff et al., 2022a], providing outer estimates and illustrated in the previous section, has a similar problem. The main difference between these two approaches is that the output approximation method, see details in [Denardi Huff et al., 2022a], will only provide a valid estimate of the RAO upon termination of the algorithm, while the inner approximation method proposed here and in [Denardi Huff et al., 2022] provides, at each iteration of Algorithm 5, a new valid contractive estimate Ω_{i, x_p} of the RAO which contains the preceding one Ω_{i-1, x_p} . The numerical examples given below presents a case where the execution of the algorithm based on outer estimations becomes prohibitively complex before its stopping criterion is reached, then failing to provide an estimate of the RAO. On the other hand, the application of Algorithm 5 is successful, even if \bar{i} is relatively small.

Finally, in [Denardi Huff et al., 2022] it is proved that, under mild assumptions on boundedness

of Γ_{SNS} , the sequence of inner estimations converges to the SNS RAO and, then, provides increasing estimation also of the RAO for the original system.

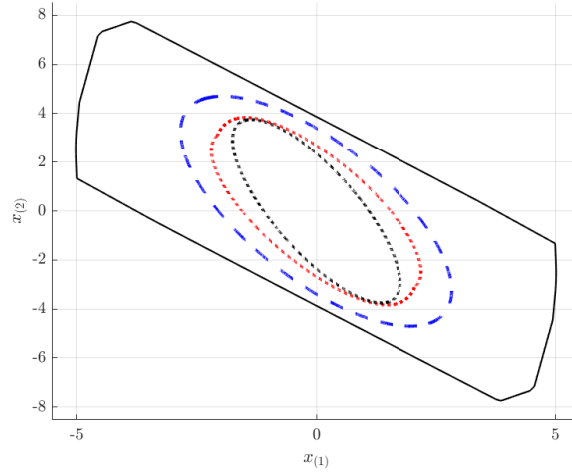

Figure 6.4: Estimates of the RAO of (6.1)-(6.20) given by the proposed approach (black-continuous) and by the methods proposed in [Seuret and Gomes da Silva Jr., 2012] (black-dotted), [Fiacchini and Gomes da Silva Jr., 2018] (red-dotted) and [Denardi Huff et al., 2022b] (blue-dashed).

6.3.2.1 Example

Consider the system taken from [Fiacchini and Gomes da Silva Jr., 2018], where:

$$A_p = \begin{bmatrix} 0 & 1 \\ 1 & 0 \end{bmatrix}, \quad B_p = \begin{bmatrix} 0 \\ -5 \end{bmatrix}, \quad K = [2.6 \quad 1.4], \quad \Delta = [0.05, 0.1].$$

The method based on outer approximations is applied. Choosing $\lambda = 0.98$ and $\lambda^* = 0.99$ and considering as initial set Ω_0 a square of size 20 centred at the origin, the algorithm gives, for $J = 140$, the polytope Ω_{35} displayed in Figure 6.4, which is an estimate of the RAO of (6.1)-(6.20). In this case, the contractivity factor of Ω_{35} is given by $\nu(\Omega_{35}, 140) \cong 0.999 < 1$. For comparison purposes, the figure also shows the piecewise quadratic estimate obtained with the conditions proposed in [Fiacchini and Gomes da Silva Jr., 2018] and the ellipsoidal estimates obtained through the methods presented in [Seuret and Gomes da Silva Jr., 2012] and [Denardi Huff et al., 2022b]. The approach presented here results in an estimate of the RAO that includes the other ones.

6.3.2.2 Example

Consider the three-dimensional system (6.1)-(6.20) with:

$$A_p = \begin{bmatrix} 0.75 & 0.35 & 1.75 \\ 0.7 & 0 & 0.7 \\ 0.75 & -1.1 & 1.75 \end{bmatrix}, \quad B_p = \begin{bmatrix} 0.7 \\ 0 \\ 0.7 \end{bmatrix}, \\ K = [-24.82 \quad -22.85 \quad 11.13], \quad \Delta = [0.1, 0.2].$$

Choosing $\lambda = 0.8$ and $\lambda^* = 0.95$ and considering as initial set Ω_0 a square with side of size 20 centred at the origin, the outer approximations algorithm leads, for $J = 100$, to the polytope Ω_{12} displayed in Figure 6.5, where $\nu(\Omega_{12}, 100) \cong 0.99 < 1$.

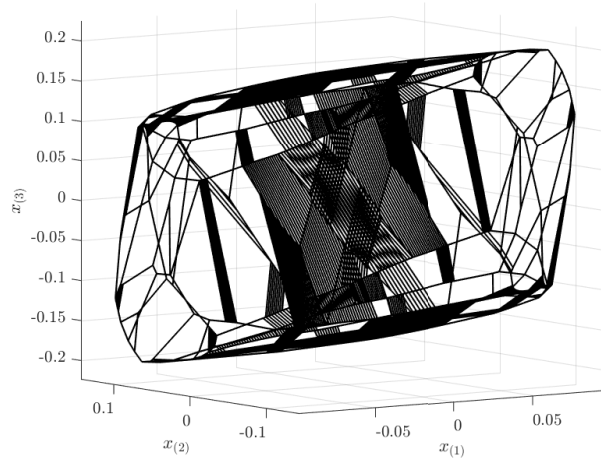

Figure 6.5: Estimate of the RAO of (6.1)-(6.20) given by the outer approximations approach.

6.3.2.3 Example

Consider the system taken from [Seuret and Gomes da Silva Jr., 2012], where $\Delta = [0.5, 2]$ and

$$A_p = \begin{bmatrix} 1.1 & -0.6 \\ 0.5 & -1 \end{bmatrix}, \quad B_p = \begin{bmatrix} 1 \\ 1 \end{bmatrix}, \quad K_p = [-1.7491, 0.5417]. \quad (6.50)$$

The inner approximation approach is applied. The initial set Ω_0 required by Algorithm 5 was obtained using the method in [Fiacchini and Morărescu, 2016] and, at each iteration, the value of J is incremented using the rule $J \leftarrow \lceil 1.05J \rceil$, where $\lceil c \rceil$ is the smallest integer greater than or equal to c . Considering $J_0 = 20$ and $\bar{i} = 9$, Figure 6.6 shows the increasing sequence $\{\Omega_{i,x_p}\}_{i=0}^{\bar{i}}$ of estimates of the RAO, computed from $\{\Omega_i\}_{i=0}^{\bar{i}}$ according to (6.49). For ease of viewing we performed in the plot the transformation of coordinates $z_p = Tx_p$, where matrix T corresponds to a contraction in the direction of $[\cos(72^\circ) \ \sin(72^\circ)]^T$ by a factor of 20. Notice that Ω_{6,x_p} is considerably close to the last 3 sets of the sequence. However, its complexity is significantly smaller, since the H-representation of Ω_6 has 154 hyperplanes, while the one of Ω_9 has 302 hyperplanes, which shows the trade-off between number of iterations and complexity.

In Figure 6.7, the estimate $\Omega_{\bar{i},x_p}$ of the RAO is compared to other ones from the literature. The piecewise quadratic estimate obtained with the method in [Fiacchini and Gomes da Silva Jr., 2018] and the ellipsoidal estimate obtained with the one from [Denardi Huff et al., 2022b] are depicted. The inner approximation approach resulted in an estimate of the RAO that includes these other two. On the other hand, it was not possible to obtain a valid estimate using the method in [Seuret and Gomes da Silva Jr., 2012] since the corresponding matrix inequalities are not feasible for this example. Moreover, the stop criterion of the algorithm given in [Denardi Huff et al., 2022a] was not satisfied after nearly 3 days of execution on a computer with a Intel® Core™ i7 processor, i.e. it was not possible to obtain a valid estimate of the RAO using the method in [Denardi Huff et al., 2022a] either.

An approximation of the RAO is shown in Figure 6.7 through black circles, where, for each point of a grid of the state space, 2000 trajectories of the closed-loop system starting at it were simulated, considering $\{\delta_k\}_{k \in \mathbb{N}}$ to be a sequence of independent, identically distributed (i.i.d.) random variables with uniform distribution on the interval Δ . As it can be seen, the proposed

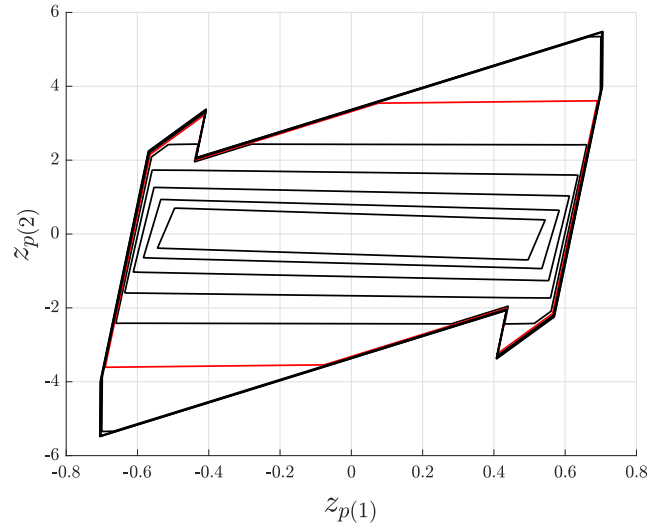

Figure 6.6: Sequence $\{\Omega_{i,x_p}\}_{i=0}^9$, where Ω_{5,x_p} is in red.

approach provided a considerably accurate estimate of the RAO (specially if compared to the methods of [Denardi Huff et al., 2022a, Fiacchini and Gomes da Silva Jr., 2018]).

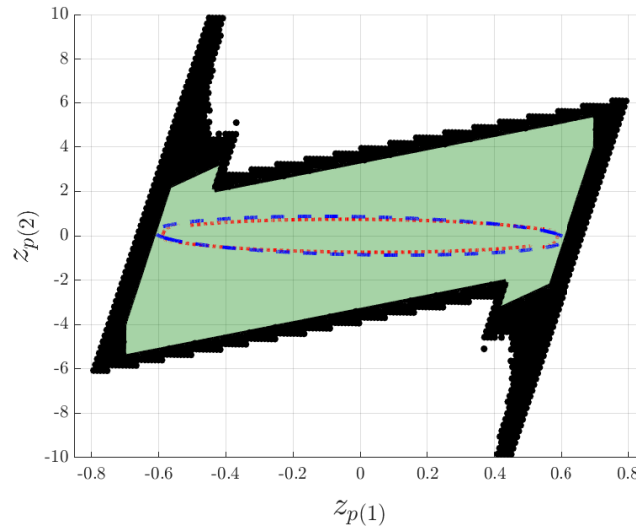

Figure 6.7: Estimates of the RAO of (6.50) obtained with the proposed approach (filled in green) and with the methods of [Denardi Huff et al., 2022b] (blue-dashed line) and [Fiacchini and Gomes da Silva Jr., 2018] (red-dotted line). A numerically evaluated approximation of the RAO is depicted by black circles.

Figure 6.8 shows several continuous-time trajectories of system (6.50) with $x_p(0) \in \partial\Omega_{i,x_p}^-$ and δ_k randomly chosen in the interval Δ . Notice that the set Ω_{i,x_p}^- is not invariant for the continuous-

time system. It is only invariant with respect to the discrete-time trajectory $\{x_p(t_k)\}_{k \in \mathbb{N}}$ that models the behavior of $x_p(t)$ at the sampling instants t_k , represented in the figure by black circles. Nevertheless, it is ensured that for all initial conditions in $\Omega_{\bar{i}, x_p}$ the corresponding continuous-time trajectories converge to the origin. Figure 6.8 also shows the division of $\Omega_{\bar{i}, x_p}$ in $3^m = 3$ polytopes. Notice that, even if $\Omega_{\bar{i}}$ is convex, $\Omega_{\bar{i}, x_p}$ is not convex in general.

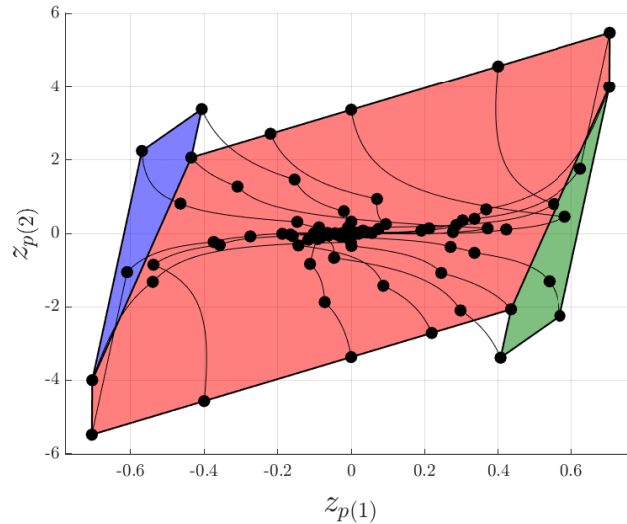

Figure 6.8: Trajectories starting at the boundary of $\Omega_{\bar{i}, x_p}$.

6.4 Conclusions

This chapter presented some results on stability analysis, control design and region of attraction estimation for linear systems subject to aperiodic sampling and input saturation, two of the most widely diffused phenomena affecting dynamical systems interacting with digital devices. Different approaches have been employed that share, though, common tools, specifically convex optimization and set-theoretic and invariance methods, and aiming at analogous results, concerning their practical applicability.

Approaches based on quadratic Lyapunov functions and ellipsoidal invariant sets led to convex conditions in form of LMI that can be employed for control design, besides stability analysis, but at the price of some conservatism in the obtained estimations of the region of the attraction of the origin. Less conservative, but computationally more involved approaches are also presented, highlighting the unavoidable trade-off between complexity on one side and precision and performance on the other.

Conclusions and Perspectives

Contents

7.1 Stochastic systems	102
7.1.1 Stochastic invariance and MPC	102
7.1.2 Stochastic switched systems	103
7.1.3 Stochastic aperiodic sampling	104
7.2 Control and learning applications	106
7.2.1 Anesthesia monitoring	106
7.2.2 Anode effect predictor for aluminium production	109
7.2.3 Privacy preservation of mobility data	111

The research activity I have been developing in the last few years presents a fundamental continuity with my long-lasting research topics but also relevant novel directions, both on the theoretical methods and on the application approaches. If on one hand several theoretical contributions strongly resort on set theory, invariance and optimization-based methods for control, that have been the main underlying topics of my research since my PhD, on the other I have been interested on the essential problems of application and applicability of control techniques to real world practical problems. Although of course the two research topics are by no means disjointed, being in practice both present in most of my recent research production, two points of view on my recent research can be highlighted.

- Regarding the first class of topics, set-theoretic methods refer to those techniques concerning properties shared by all the elements of sets of the state space. A particularly important example in the field of dynamical systems and control design involving set-theoretic methods is represented by invariance. An invariant set, for a given dynamical system, is a region of the state space such that the trajectory generated by the system remains confined in the set if the initial condition lies within it, see [Blanchini and Miani, 2008]. The concept of invariance has become fundamental for the analysis and design of control systems, in particular in presence of constraints and for optimization-based control, like model predictive strategies. Many of the theoretical results obtained, concerning for instance stability and stabilizability of saturated, aperiodically sampled and switched systems, and also model predictive control, strongly rely on set theory and invariance for dynamical systems, often providing an alternative point of view on the treated problems.
- Concerning the second line, I have been recently focusing both on the theoretical aspects and practical application issues of phenomena that might affect the real implementation of control. I considered for instance the problems of aperiodic sampling and of saturation, the often unavoidable presence of uncertainties and perturbations, but also the potential opportunities offered by the efficient numerical tools nowadays available to deal with real-world control problems. On this line, I have been directing part of my research effort to solutions resorting on data-based modelling approaches, in particular for industrial and biological systems, and on machine learning and non-convex optimization tools for identification and control. I have also been directing part of my research to the theoretical analysis of systems

affected by stochastic uncertainties and perturbation, that is a modelling framework often more adequate to represent the real systems variability.

The main lines of my future research follow, in one sense, the research direction of the new GIPSA-lab research team MODUS, that has been created in January 2020 and I am directing. In a context where the theory for modelling, estimating, analysing, and controlling dynamical systems have reached a certain maturity for the cases of well-defined and deterministic models, it is important to focus on the effects of partial lack of exact knowledge and of the uncertainties on this theory. Uncertainties on the data, on the operation environments, or on the models themselves are often unavoidable when dealing with real systems. These uncertainties must therefore be considered to provide results that might conjugate the strong theoretical properties of control theory with the practical applicability requirements necessary when dealing with the real world.

For this, my current and future research should aim at employing and developing novel control and modelling methods, based for instance on optimal and predictive control; stochastic invariance and MPC; data-based control; machine learning for classification and regression, to manage the lack of knowledge and the uncertainties. This approach should permit to apply the theoretical results on control to real systems and then maintain and even strengthen the tight collaborations with the industrial and institutional partners on multidisciplinary projects.

7.1 Stochastic systems

Possible research lines, related to the effort for taking into account the effects of the unavoidable uncertainties on the modelling and then control of dynamical systems, are concerned with the stochastic nature of real world systems.

7.1.1 Stochastic invariance and MPC

Model Predictive Control is nowadays a mature control technique whose popularity mostly relies on its capability for dealing with constraints and for ensuring performance optimization and on its suitability for practical application, by guaranteeing, at the same time, desirable stability properties. The inherent importance on the control implementation led to focus on the effects of model uncertainties, disturbances and noises on the control performances and stability, yielding to robust formulations of MPC. If in the beginning many of the researchers efforts have been devoted to the robust formulation under worst-case assumptions on the uncertainties, last years witness a shift of the interest to stochastic MPC (SMPC), [Farina et al., 2016, Mesbah, 2016, Mayne, 2018]. SMPC, in fact, permits to take into account the stochastic nature of the uncertainties, exploiting the knowledge of their distribution, and to deal with probabilistic chance constraints, reducing the conservatism inherent to robust MPC. Stochastic MPC found application in building climate regulation, process control, power production and management, vehicle power and steering control, robot path planning, etc, see [Farina et al., 2016] and references therein.

In many of the works concerning the stability analysis of SMPC, however, the stochastic disturbance is modelled by an independent, identically distributed sequence of random variables. This is the case, for instance, for the methods based on stochastic tube MPC, [Cannon et al., 2011, Hewing and Zeilinger, 2018], SMPC for controlling the average number of constraints violation [Korda et al., 2014a] and probabilistic MPC [Farina et al., 2015]. The assumption of independence in time, and thus uncorrelation, between disturbances, though, is in general unrealistic.

Moreover, different approaches have been appearing in the recent years to formulate adapted definitions of recursive feasibility for the stochastic MPC framework, since the direct extension of definitions and methods, proper of the deterministic and robust frameworks, seems to lead to

novel conceptual problems. Indeed, the effects of potentially unbounded disturbances pose substantial issues on the fundamental underlying assumption on which recursive feasibility and MPC convergence are based, that is the fact that an optimal solution defines a feasible solution at future instants. This is no more the case, in general, when disturbances with unbounded support, with normal distribution for instance, are considered. Although different approaches are present in the literature, for instance those based on boundedness assumption and robust approaches [Kouvaritakis et al., 2010, Kouvaritakis and Cannon, 2016] and those ensuring properties conditioned to the initial measures [Rawlings et al., 2017, Farina et al., 2016, Farina et al., 2013, Hewing and Zeilinger, 2018, Hewing et al., 2020], the formulation of an appropriate concept of recursive feasibility and the determination of conditions for guaranteeing it are still open problems.

- A first research line should consider first stochastic systems excited by disturbances whose realizations are correlated in time. Only bounds on the mean and the correlation matrices should be required to be known, even stationarity might be not necessary. Based on recent results on the probabilistic reachable and invariance sets for correlated disturbances, see [Fiacchini and Alamo, 2020], a novel formulation of probabilistic recursive feasibility for MPC, adequate to the stochastic framework, is aimed. Moreover, recent works are appearing that witness the relevance of the problem, as those based on probabilistic validation [Mammarella et al., 2020] and learning methods [Karg et al., 2021]. The formulation of constructive and computationally tractable conditions for ensuring it and for proving convergence of the resulting SMPC is a first objective. Furthermore this line should lead to the formulation and characterization of novel concepts of probabilistic recursive feasibility and convergence in distribution for stochastic MPC that might overcome the inherent limitations of the feasibility and convergence properties inherited from robust MPC and currently employed in the recent literature on the subject, often resorting on the conditional probabilities with respect to the initial state.
- A second research subject related to SMPC concerns novel characterizations and computational methods of invariant sets for systems affected by stochastic uncertainties. Although some work recently appear on this topic, for instance [Kofman et al., 2012, Hewing et al., 2018, Hewing and Zeilinger, 2019] besides [Fiacchini and Alamo, 2020], the problem of providing an efficient way of computing probabilistic invariant and reachable sets based on the measured data or under more realistic assumptions on the stochastic processes involved is still open. Assumptions on the stochastic disturbance, indeed, are often supposed to hold to obtain probabilistic guarantees, for instance on the process stationarity, on time uncorrelation or on, at least partial, knowledge on the process parameters. When dealing with real systems, though, it is not always possible to assess those assumptions fulfilment. Data-based methods for the design of invariant and reachable sets might deserve to be investigated. On this topic, probabilistic validation approaches based on randomized algorithm [Alamo et al., 2009b, Cal, 2011, Tempo et al., 2013, Alamo et al., 2015] and machine learning tools [Marsland, 2011, Géron, 2019] could be used to compute invariant sets estimates and to obtain probabilistic guarantees of invariance of the computed sets.

7.1.2 Stochastic switched systems

Recently I have started working at the problem of analysis of switched systems affected by stochastic additive uncertainties, in collaboration with **T. Alamo from the University of Seville**. Related to the necessity of representing the natural complexity of the real world dynamics, in fact, the presence of stochastic uncertainties on the model parameters and disturbances affecting the systems has recently attracted the interest of the automatic control community, see for instance [Chatterjee and Liberzon, 2006, Colaneri, 2009, Feng et al., 2011, Zamani et al., 2015, Lavaei et al., 2020].

The presence of additive uncertainties led, in the general case of linear systems, to the problem of covariance control. Covariance control has been addressed in the literature since the 80s, see [Collins and Skelton, 1987, Hsieh and Skelton, 1990], and regards the design of controllers such that the covariance matrix of the state of linear systems affected by additive stochastic noises are steered to the desired matricial value. Few works, though, concern the covariance control for switched systems, a notable exception being [Klett et al., 2020], that considers systems driven by arbitrary switching sequences, leading then to robust covariance bounds.

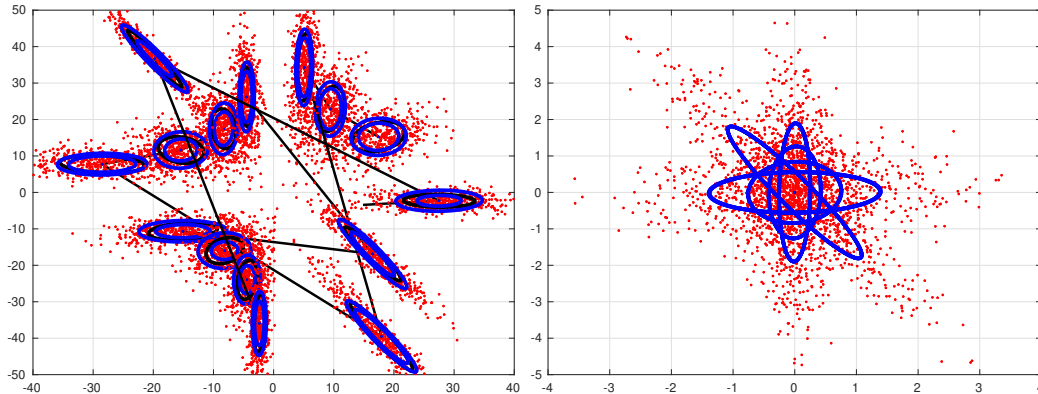

Figure 7.1: Left: Sequences of covariance ellipsoids, of inner and outer ellipsoidal bounds and sets of 500 random points. Right: limiting ellipsoids and sets of 500 random points sampled.

This research line concerns the problem of covariance control for discrete-time switched systems under a stabilizing switching law. The practical interest of the problem lies on the ability of modelling, for instance, the covariance control for multi-sensor systems, whose state estimation evolution depends on the discrete selection of the sensors, see for instance [Kalandros, 2002]. The aim is, then, to determine upper and lower bounds of the covariance matrices and the limiting covariance matrix under a stabilizing switching sequence, to infer the stochastic evolution of the controlled state. Preliminary results appear recently in [Fiacchini and Alamo, 2022], in which a given stabilizing switched sequence is considered. Figure 7.1, taken from [Fiacchini and Alamo, 2022], shows, on the left, the evolution of inner and outer bounds of ellipsoids generated by time-varying bounds of the covariance matrices and the limiting ellipsoids given by the cyclic limit of the covariance, with the evolution and limits of randomly generated points.

These preliminary results should be further developed to design switching control strategies that allow to optimize measures of the evolution of the covariance of the states, and also to enforce probabilistic guarantees of constraints satisfaction analogous to those present in the stochastic MPC framework. Moreover, in terms of probability, convergence in distribution of the state might be formally analysed and possibly used to provide probabilistic characterization of the controlled state evolution.

7.1.3 Stochastic aperiodic sampling

The main issue this research line would be addressed to concerns the characterization of the theoretical features as well as the practical aspects related to dynamical systems affected by aperiodicity in the sampling and saturations on the actuators. This class of systems received a growing attention in the last years, as a particular subclass of the called Cyber-Physical Systems (CPSs), [Khaitan and McCalley, 2015]. My recent research on this topic aimed at providing constructive

conditions to ensure the stability of the closed loop, to be eventually used to design appropriate control laws for dealing with the presence of aperiodic sampling and saturations, under the assumption of unknown but bounded sampling intervals.

The same problem of aperiodic sampling of linear systems affected by saturated input has been recently considered also under a different assumption on the sampling interval. A common feature of the aforementioned references is that they consider a non-stochastic framework, where hard bounds are given for the time-varying sampling interval. However, taking into account that this assumption may not be realistic, some recent works have addressed the stability analysis and stabilization of linear sampled-data systems subject to a random sampling interval, where the corresponding distribution function has possibly unbounded support. The sampling interval sequence is often considered, in particular, as a Poisson process. On this topic, we have proved that, by considering the input as a feedback law of both the measured state and also the previously applied input value, the stabilization condition of linear systems (with no saturation) is equivalent to a convex condition expressible in LMI form. Thus, the LMI condition is non-conservative and exactly characterizes the problem of designing a control feedback that stabilizes a linear system under Poisson sampling process. These results are presented in [Denardi Huff et al., 2022].

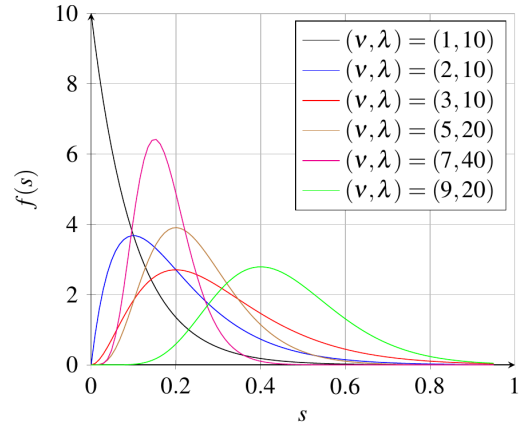

Figure 7.2: Erlang distributions.

- The first objective of this research line is to consider more general classes of non-linearity in the closed loop and more generic random sampling processes. It seems possible, in fact, that the results holding for sampling period modelled by a Poisson process and presence of input saturation can be extended, for instance for Erlang processes, see Figure 7.2, and generic sector conditions-based nonlinearities. Furthermore, it seems possible to consider also the presence of a probabilistic dropout phenomenon preventing the control update with a given probability distribution. This research line has already been started in collaboration with **J.M. Gomes da Silva Jr.** and **D. Denardi Huff**.
- Another scientific objective would concern recent results on stability of observers for linear systems under sporadic measurements by **F. Ferrante** currently at University of Perugia, see [Ferrante et al., 2016]. Those results, recently applied also in the context of output regulation for linear systems under sporadic measurements [Basu et al., 2022], resort to properties of aperiodic sampling in linear systems, as the observation error dynamics presents sporadic reset due to the measurements update. The underlining assumptions on the sporadic measurements, though, implicitly consider the update interval to be unknown but bounded within a known time interval, as for the framework treated so far in my research on this topic. The more natural assumption of stochastic nature of the measurement intervals might be considered and the stability analysis could be carried on in this framework, both for state observer and output regulation in presence of sporadic measurements. This line, already started together with **F. Ferrante** and **H. Basu**, a post-doctoral researcher currently at GIPSA-lab under my direction, might be inspected to get results also for the stochastic case and with the additional presence of further nonlinearity in the loop.

7.2 Control and learning applications

Regarding the effort of applying analysis and control design for real systems, some projects are going to be addressed, whose main challenges are listed hereafter. On these application-oriented research, a central role will be played by the synergy between dynamical systems theory and machine learning tools, that already proved its efficiency when dealing with data-based and uncertain models issued from the real world.

7.2.1 Anesthesia monitoring

During general anesthesia, one of the anesthesiologist's tasks is to continuously regulate intravenous drug rates to set hypnotic and analgesic levels to desired values while maintaining hemodynamic and respiratory variables stable. Since the development of fast-acting intravenous drugs like Propofol and Remifentanyl combined with reliable hypnotic indicators based on EEG signals like Bispectral Index (BIS), many models have been proposed to predict the influence of the drugs on the patient's physiological state [Marsh et al., 1991, Schnider et al., 1999, Minto et al., 1997, Jaap et al., 2020, Copot, 2020].

The development of such models is supported by the idea of helping the practitioner to better dose the drugs with the final objective to improve patient recovery. Currently, the standard practice of anesthesia includes the use of Target-Control-Input (TCI) pumps to inject hypnotic and analgesic drugs [Struys et al., 2020]. With this device, the anesthesiologist selects the desired effect-site drug concentration (C_e) for each drug, and the TCI sets, in an open-loop manner, a drug rate to reach the target value of C_e according to a given model. Then the loop is closed by the anesthesiologist to obtain the desired levels of hypnosis and analgesia. While TCI has already improved the practice of anesthesia, some researchers are interested in closing the control loop to fully automate the drug dosage. Up to now, studies have shown the advantage of closed-loop control for anesthesia drugs [Brogi et al., 2017, Pasin et al., 2017], but research is still active on the development of an optimal and reliable control method [Loeb and Camnsson, 2017].

Several open problems deserve to be addressed to assist the anesthesiologist and improve the anesthesia process safety.

- One of the main sources of complexity in these research fields is the uncertainty affecting the models used to describe the influence of drugs on vital signals. In fact, the inter- and intra-patient variability of the physiological effects along with the exogenous disturbances coming from the surgeon's actions make difficult the task of predicting drug influences. As a consequence standard models may not always be capable to accurately reproduce the measured data.

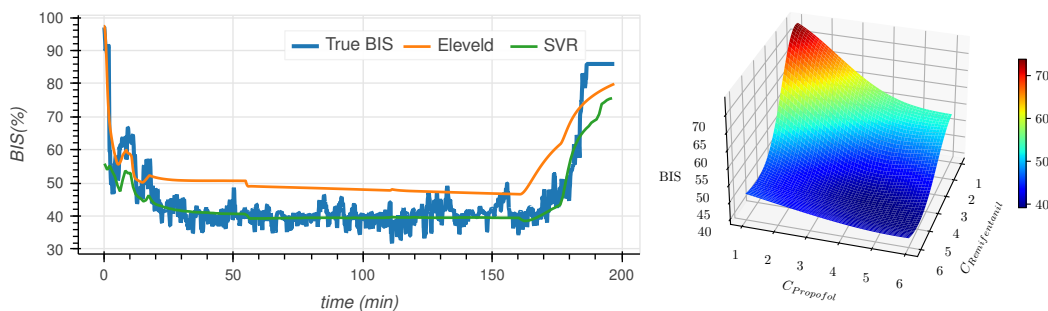

Figure 7.3: Left: BIS prediction comparison of Eleveld model and SVR one. Right: BIS surface response of a reference individual from SVR.

Drugs models are usually composed by two elements: Pharmacokinetic (PK) and Pharmacodynamic (PD). PK models describe the dynamics of drug concentrations in the patient's

body, and are used by TCI devices. PD models describe the link between plasma drug concentrations and a given physiological effect. In the most used models, PK is described by a multi-compartments system while PD is represented as a Hill-curve function that can take into account interactions between drugs. In practice, due to the lack of direct measurements of drug concentrations, it might be impossible to identify at the same time the parameters of both the dynamic model (PK) and the output function (PD). Several studies have been conducted in order to link the patient personal data (age, height, weight, sex) to the model parameters, the most popular being [Marsh et al., 1991, Schnider et al., 1999] for Propofol and [Minto et al., 1997] for Remifentanil. More recently, two more studies appear [Eleveld et al., 2018, Eleveld et al., 2017] based on wider databases, that can be considered as the new state of the art on the subject.

Furthermore, an additional complexity of the modelling process is the interactions and synergies between the different drugs. It is in fact known by the practitioners that, for instance, the analgesic drug Remifentanil has an effect on the hypnosis level, that is directly controlled through the regulation of the hypnotic drug perfusion rate, Propofol in most cases. Moreover, there is a reciprocal interaction between the hemodynamics state and drugs and the hypnosis evolution. For instance, the variation on the blood pressure and cardiac output affect the diffusion rates between different compartments and the clearance rate and then the effects and evolution of the Propofol drug concentration. On the other hand, a depressive side-effect of Propofol on the hemodynamics parameters is observable.

Thus, from the dynamical systems point of view, although the compartmental structure might be considered well-assessed, the models must unavoidably take into account the parameter uncertainty and the drugs and systems interactions. This inherent complexity due to variability and dynamical systems interaction pose a non-trivial problem of identification, whose complexity is increased by the almost total absence of available measurement of the involved state, namely of the drugs concentrations in the different compartments. From the modelling point of view, then, the problem would result to be analogous to the issue of identifying the model and estimating the state simultaneously, based on an assessed model structure. This is the reason why the most popular dynamical models, used also in the TCI devices for inferring the drugs concentrations, might fail to properly reproduce the input-output dynamical relation between the drugs perfusion rates and the observed evolution of the patient physiological signals. On the other hand, rich databases are available providing plenty of records of data series of those physiological signals, as the BIS, the Mean Arterial Pressure (MAP), the Heart Rate (HR), and others, as well as the drugs concentration estimations computed and the drug perfusion rates generated by the TCI.

Therefore, the available data might be used to better fit models, potentially depending on further parameters such as the hemodynamical signals, for instance, to implicitly take into account the different physiological systems interactions. Moreover, this would allow to design methods for online tuning them based on the measured signals. On this topic, machine learning techniques are precious tools to infer the functional relation between the several measured output signals, the drug infusion inputs and the estimated concentrations to tune a structured data-based model, capable to better explain and predict the patient state evolution and then be used to control the anesthesia levels. Preliminary promising results have already been obtained, in the framework of DAMon project, and submitted to international conferences. A hint on the results of the proposed data-based modelling is given by Figure 7.3, where the prediction precision of a mixed dynamical/learning model is compared to the established model, on the left, and the interaction surface of the joint Propofol/Remifentanil effect on the BIS evolution is shown, on the right.

- Another important issue that deserves to be addressed regards the detection and, if possible, the prediction and compensation of undesirable effects on the hypnosis due to exogenous

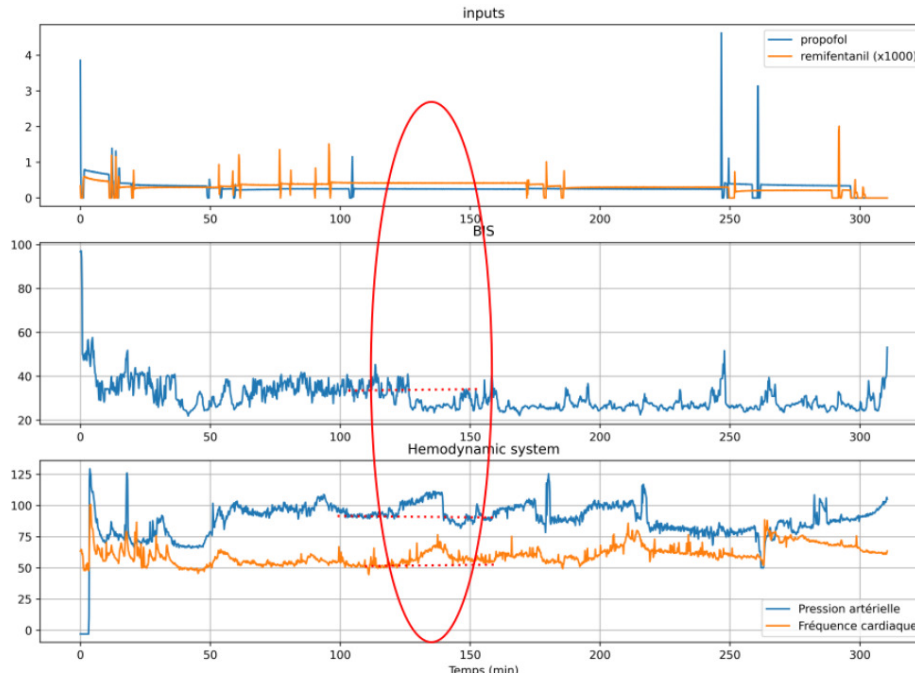

Figure 7.4: Evolution: of the Propofol and Remifentanyl infusion rates (top); of BIS signal (middle); and MAP and hearth rate (bottom).

causes. If on one side, in fact, the PK/PD model allows to represent the dynamical relation between the drug perfusion rates and the physiological effects on the patients, specifically those involved in the hypnosis, other causes affect them. The actions of the surgeon, for instance, or undesirable phenomena, as allergic reactions, bleeding and hypo-tension, generate perturbations on the physiological signals such as the BIS and the MAP. A critical task of the anesthesiologist is to detect those artifacts of the measurement signals to then identify the potential cause and, if necessary, react to compensate the undesired consequences on the patient state. For example, as illustrated in Figure 7.4 by real surgical data, the evolution of the BIS and the MAP between the minutes 120 and 150 cannot be explained by the drug infusion rates, they must be due to other external causes that should be identified. Moreover, other signals can be employed for detection purposes, like the end-tidal capnography $ETCO_2$ (that measures the concentration of carbon dioxide in the patient respiration) and the oxygen saturation, often available in modern surgery.

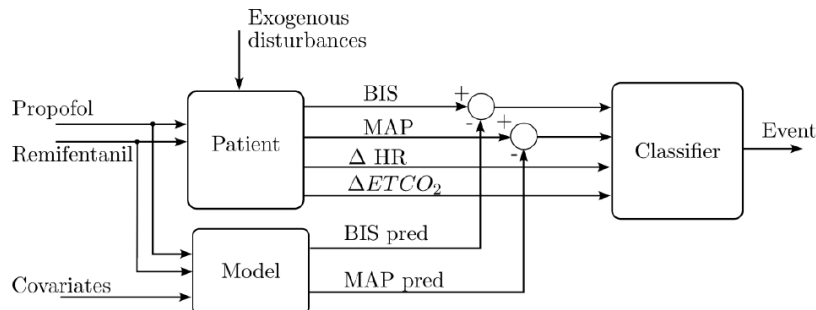

Figure 7.5: Events detection and classification scheme.

Recently, works are appearing on detecting anomalies during surgery in order to preserve the

vigilance of anesthetists on potential critical events [Jove et al., 2019, Maciag et al., 2022], witnessing the relevance of the problem. Also on our side, the anesthesiologists of CHUGA, Grenoble, with whom we are collaborating, express the interest on the exogenous perturbations detection and classification. The task could be addressed by resorting the data-based model to obtain accurate estimation of the concentrations and thus of the expected output values, to be compared with the measured signals. The difference between the model-based estimations and the measurements can then be used as features to infer whether something is occurring that is not explainable by the drug concentration dynamics and therefore classify the potential cause, see Figure 7.5. The final objective is to design a numerical alarm generator able to discriminate the normal observed evolution from the effects of exogenous causes and then classify them, to assist the anesthesiologist during the surgery operation, see an example in Figure 7.6.



Figure 7.6: Events detection example.

7.2.2 Anode effect predictor for aluminium production

The electrochemical reaction of aluminium production, occurring in the pot cell, can be written in a global way as [Thonstad et al., 2001]:

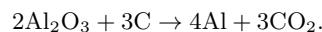

The carbon is that of the anodes, which explains their consumption. Alumina, Al_2O_3 in the stoichiometric formula, is the raw material dissolved in the bath and consumed by the reaction. Obviously, for this reaction to take place, alumina must be present in sufficient quantity in the cryolith bath which acts as the supporting electrolyte. When this is no longer the case, the anode effect occurs, in which the process switches to another electrochemical mode, much more energy

consuming:

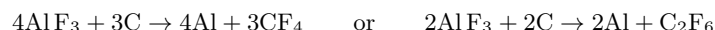

These two reactions consume AlF_3 which is present in the electrolyte of the cell, the cryolite. The formed gases CF_4 and C_2F_6 strongly contribute to the greenhouse effect, 6000 to 9000 times more than carbon dioxide.

In addition, these reactions significantly increase the pot voltage since they consume more energy than the expected one and since, moreover, the produced gases tend to form bubbles that stick under the anodes, highly increasing the resistance. The voltage could then pass from the nominal value of around 4 volts to several tens. The transition from the nominal voltage to a high voltage is sudden and therefore can be difficult to be predicted and then compensated in advance. Furthermore, the energy excess generated during the anode effect can damage the pot cell if the heat is not evacuated rapidly. In addition, any single anode effect, even if brief, can have negative consequences on the Faraday efficiency of pot, and then on its productivity. The economic impact of this phenomenon is therefore major.

An anode effect treatment algorithm is currently implemented in the control system of the aluminium production pot cell, consisting in shaking the anodes to remove the gases bubbles and in boosting the alumina injection to compensate its low concentration. Nonetheless, even if the algorithm is very efficient, it is often triggered only when the anode effect is already spread to the whole cell. Although some studies on the anode affect prevention have been appearing, the problem has not been solved yet. The works realized on early detection of anode effect have not led to satisfactory results, either because the resulting algorithms are unable to predict it more than a few seconds in advance, or because the number of false positives is too high to consider implementing it. Nevertheless, if early detection were possible, it would have a very significant financial and environmental impact.

The first objective is to obtain on-line estimates of the local alumina concentration below each anode, by using both the measured signals and the known relationships between the anode-cathode distance (ACD), alumina concentration and anode resistance. The alumina concentration, in fact, is not generally homogeneous in the cryolite bath, due to diffusion and convection phenomena and to localized injections of alumina in powder form. Moreover, the local concentration also depends on the production efficiency of each anode. Thus, estimators of the local concentration of alumina must be designed and then used for predicting its low values, potential causes of anode effects. Based on the results of the predictions, the local alumina dosage could then be preemptively adjusted to minimize or eliminate the undesired consequences and the occurrences of anode effect.

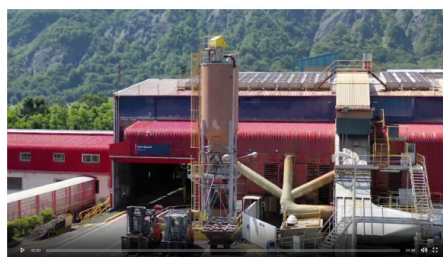

Figure 7.7: Rio Tinto's Laboratoire des Recherches de Fabrications (LRF), in Saint Jean de Maurienne.

The main problem that prevents a direct application of classical identification and estimation methods is the almost total absence of measurements of alumina concentration and ACD. In addi-

tion, the relationship between resistance, ACD and alumina also depends, albeit weakly, on other bath parameters, such as temperature and aluminium fluoride (AlF_3) concentration, introducing slow variations and small uncertainties in the function relating the estimated variables.

Efficient numerical tools for non-convex optimization [Andersson et al., 2018] and machine learning [Smola and Vishwanathan, 2008, Marsland, 2011, Géron, 2019] can be used to obtain estimates of local values of alumina and ACD, as well as the parameters of their dynamical models, by minimizing the differences between the measured signals and those obtained from the estimate over an observation window. The methods could rely on a large amount of data from the APXe pot cell at Rio Tinto’s Laboratoire des Recherches de Fabrications (LRF), which is located in Saint Jean de Maurienne, see Figure 7.7, already used in the FUI project. Once a numerical tool will be designed for the on-line estimation of local values of alumina concentration present below each anode, the objective will be to infer the correlations between these values and the future possibility of an anode effect occurrence. For this purpose, based on the available data, supervised machine learning techniques, which are very efficient for classification and functional estimation, can be applied to detect correlations between the evolution of alumina contents and possible future anode effects.

7.2.3 Privacy preservation of mobility data

With the generalization of smart mobile devices, such as phones or smart watches, location data are more than ever a goldmine. Geo-located services are flourishing, such as navigation, location finders or dating apps [Google Play, 2022]. Share one’s mobility data to a third party presents however threats to privacy, by exposing highly sensitive personal information. Extracting location points of interest, attackers can discover users’ identity, social relationships, and even religious, political or sexual orientations [Gambis et al., 2011].

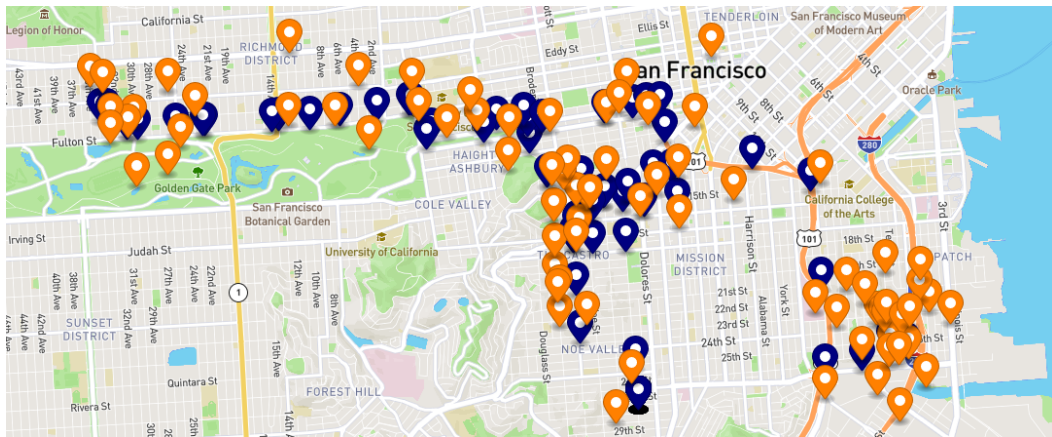

Figure 7.8: Mobility trace: actual position (blue), and Geo-I obfuscated one (orange)

Protection mechanisms have been proposed to enhance one’s location privacy. Among the vast literature [Primault et al., 2018, Jiang et al., 2021], some works tackle the scenario of an individual continuously sending his or her mobility data. Such protection mechanisms are mainly based on obfuscation: the location data is disturbed with some spatial noise before being transmitted to the service as in Geo-Indistinguishability [Andrés et al., 2013], inspired from the concept of differential-privacy [Dwork, 2006]. Geo-I realizes blind obfuscation, as it applies constant noise for all locations and at all times, see an example in Figure 7.8. More recently this first limitation has been addressed with location-dependent privacy [Koufogiannis and Pappas, 2016,

[Chatzikokolakis et al., 2015], correlating the noise to the location population density. The adaptation of the noise in time is still an open challenge, though. The work [Chatzikokolakis et al., 2014] takes a step in this direction by taking into account the predictability of the user movement to take a binary decision on whether to obfuscate or not the transmitted location.

Most of the obfuscation techniques relies on information-theoretic approaches to enhance privacy protection, resorting to determine the additive noise energy employed to obfuscate the real user position. The problem of privacy preservation, though, consisting to maximizing the privacy measure by ensuring a certain utility level, results to be an optimization problem with conflicting objectives. Moreover, since the privacy is often defined as a function of the user positions transmitted within a time window and depends on the user movements, the dynamical nature of the privacy evolution should be considered to enhance the obfuscation algorithm results. Therefore, methods based on optimization and control theory should be considered to address some of the problems of privacy preservation on mobility data.

This research line, whose preliminary work is developed in collaboration with **B. Robu from GIPSA-lab** and **S. Cerf from INRIA Lille**, should aim at applying optimal and predictive control techniques to the problem of privacy preservation whose objective is to compute the optimal obfuscation signal aiming at pursuing the conflicting objectives of increasing the privacy and minimizing the utility loss. On this line, it will be important, on one hand, to design and use mobility prediction to improve the optimal control-based obfuscation algorithm. On the other, it will be necessary to design numerical methods to obtain sub-optimal solutions of the resulting predictive control approach that take into account the computational limitation of mobile devices, on which they might be implemented. On this line, machine learning techniques might provide efficient tools for estimating the optimal obfuscation protocols through implementable functions.

Bibliography

- [Cal, 2011] (2011). Research on probabilistic methods for control system design. *Automatica*, 47(7):1279–1293. (Cited on page 103.)
- [Absalom and Kenny, 2003] Absalom, A. R. and Kenny, G. N. C. (2003). Closed-loop control of propofol anaesthesia using bispectral indexTM: performance assessment in patients receiving computer-controlled propofol and manually controlled remifentanil infusions for minor surgery. *British Journal of Anaesthesia*, 90(6):737–741. (Cited on pages 9 and 30.)
- [Alamir, 2014] Alamir, M. (2014). Robust feedback design for combined therapy of cancer. *Optimal control, Applications and Methods*, 35(1):77–88. (Cited on page 29.)
- [Alamir et al., 2018] Alamir, M., Fiacchini, M., Queinnec, I., Tarbouriech, S., and Mazerolles, M. (2018). Feedback law with probabilistic certification for propofol-based control of bis during anesthesia. *International Journal of Robust and Nonlinear Control*, 28(18):6254–6266. (Cited on page 9.)
- [Alamir et al., 2015] Alamir, M., Fiacchini, M., and Stéphanou, A. (2015). Reduced model for 2d tumor growth and tumor induced angiogenesis. In *The 14th European Control Conference 2015 (ECC15)*. (Cited on page 9.)
- [Alamo et al., 2009a] Alamo, T., Cepeda, A., Fiacchini, M., and Camacho, E. F. (2009a). Convex invariant sets for discrete-time Lur’e systems. *Automatica*, 45:1066–1071. (Cited on page 27.)
- [Alamo et al., 2005] Alamo, T., Cepeda, A., and Limon, D. (2005). Improved computation of ellipsoidal invariant sets for saturated control systems. In *Proceedings of the 44th IEEE Conf. on Decision and Control and European Control Conference CDC-ECC 2005*, pages 6216–6221, Seville, Spain. (Cited on pages 8 and 33.)
- [Alamo et al., 2006] Alamo, T., Cepeda, A., Limon, D., and Camacho, E. F. (2006). A new concept of invariance for saturated systems. *Automatica*, 42:1515–1521. (Cited on pages 33, 90, 91 and 92.)
- [Alamo et al., 2009b] Alamo, T., Tempo, R., and Camacho, E. F. (2009b). Randomized strategies for probabilistic solutions of uncertain feasibility and optimization problems. *IEEE Transactions on Automatic Control*, 54(11):2545–2559. (Cited on page 103.)
- [Alamo et al., 2015] Alamo, T., Tempo, R., Luque, A., and Ramirez, D. R. (2015). Randomized methods for design of uncertain systems: Sample complexity and sequential algorithms. *Automatica*, 52:160–172. (Cited on page 103.)
- [Andersson et al., 2018] Andersson, J., Gillis, J., Horn, G., Rawlings, J., and Diehl, M. (In Press, 2018). CasADi – A software framework for nonlinear optimization and optimal control. *Mathematical Programming Computation*. (Cited on page 111.)
- [Andrés et al., 2013] Andrés, M. E., Bordenabe, N. E., Chatzikokolakis, K., and Palamidessi, C. (2013). Geo-indistinguishability: Differential Privacy for Location-based Systems. In *CCS*, pages 901–914. ACM. (Cited on page 111.)
- [Antunes and Heemels, 2016] Antunes, D. and Heemels, W. (2016). Linear quadratic regulation of switched systems using informed policies. *IEEE Transactions on Automatic Control*, 62(6):2675–2688. (Cited on page 25.)
- [Athanasopoulos et al., 2014] Athanasopoulos, N., Bitsoris, G., and Lazar, M. (2014). Construction of invariant polytopic sets with specified complexity. *International Journal of Control*, 87(8):1681–1693. (Cited on pages 23 and 35.)
- [Bailey and Haddad, 2005] Bailey, J. and Haddad, M. (2005). Drug dosing control in clinical pharmacology. *IEEE Control Systems Magazine*, 25(2):35–51. (Cited on pages 9 and 30.)

- [Basile and Marro, 1969] Basile, G. and Marro, G. (1969). Controlled and conditioned invariant subspaces in linear system theory. *Journal of Optimization Theory and Applications*, 3:306–315. (Cited on page 32.)
- [Basile and Marro, 1987] Basile, G. and Marro, G. (1987). On the robust controlled invariant. *Systems and Control Letters*, 9:191–195. (Cited on page 32.)
- [Basile and Marro, 1992] Basile, G. and Marro, G. (1992). *Controlled and Conditioned Invariants in Linear system Theory*. Prentice Hall. (Cited on page 32.)
- [Basu et al., 2022] Basu, H., Ferrante, F., and Yoon, S. Y. (2022). Output regulation of linear aperiodic sampled-data systems. In *2022 American Control Conference (ACC)*, pages 868–873. (Cited on page 105.)
- [Beck, 2015] Beck, C. L. (2015). Modeling and control of pharmacodynamics. *European Journal of Control*, 24:33–49. (Cited on pages 9 and 30.)
- [Beker et al., 2004] Beker, O., Hollot, C. V., Chait, Y., and Han, H. (2004). Fundamental properties of reset control systems. *Automatica*, 40:905–915. (Cited on page 33.)
- [Bemporad and Morari, 1999] Bemporad, A. and Morari, M. (1999). Control of systems integrating logic, dynamics, and constraints. *Automatica*, 35(3):407–427. (Cited on page 7.)
- [Berg et al., 2000] Berg, M. D., Kreveld, M. V., Overmars, M., and Schwarzkopf, O. C. (2000). Computational geometry. In *Computational geometry*, pages 1–17. Springer. (Cited on page 38.)
- [Bertsekas, 1972] Bertsekas, D. P. (1972). Infinite-time reachability of state-space regions by using feedback control. *IEEE Transactions on Automatic Control*, 17:604–613. (Cited on pages 23, 27 and 35.)
- [Biedler, 2003] Biedler, P. (2003). *Modeling of an aluminum reduction cell for the development of a state estimator*. West Virginia University. (Cited on page 31.)
- [Blanchini, 1992] Blanchini, F. (1992). Minimum-time control for uncertain discrete-time linear systems. In *Proceedings of the 31st IEEE Conference on Decision and Control, 1992*, pages 2629–2634. IEEE. (Cited on pages 27 and 35.)
- [Blanchini, 1994] Blanchini, F. (1994). Ultimate boundedness control for discrete-time uncertain systems via set-induced Lyapunov functions. *IEEE Trans. on Automatic Control*, 39:428–433. (Cited on pages 7, 23, 27, 35, 53, 56 and 92.)
- [Blanchini, 1995] Blanchini, F. (1995). Nonquadratic Lyapunov functions for robust control. *Automatica*, 31:451–461. (Cited on pages 7, 23, 24, 51, 53, 54 and 56.)
- [Blanchini, 1999] Blanchini, F. (1999). Set invariance in control. *Automatica*, 35:1747–1767. (Cited on pages 7 and 23.)
- [Blanchini et al., 1995] Blanchini, F., Mesquine, F., and Miani, S. (1995). Constrained stabilization with an assigned initial condition set. *International Journal of Control*, 62(3):601–617. (Cited on pages 35 and 38.)
- [Blanchini and Miani, 2008] Blanchini, F. and Miani, S. (2008). *Set-Theoretic Methods in Control*. Birkhäuser. (Cited on pages 7, 23, 27, 35, 36, 53, 56, 90 and 101.)
- [Blanchini and Savorgnan, 2008] Blanchini, F. and Savorgnan, C. (2008). Stabilizability of switched linear systems does not imply the existence of convex Lyapunov functions. *Automatica*, 44:1166 – 1170. (Cited on pages 24, 51 and 55.)
- [Blanco et al., 2010] Blanco, T. B., Cannon, M., and De Moor, B. (2010). On efficient computation of low-complexity controlled invariant sets for uncertain linear systems. *International journal of Control*, 83(7):1339–1346. (Cited on pages 23 and 35.)
- [Bochnak et al., 1998] Bochnak, J., Coste, M., and Roy, M. F. (1998). *Real algebraic geometry*. Springer. (Cited on page 55.)
- [Boukerrou et al., 2022] Boukerrou, H., Millérioux, G., Minier, G. M., and Fiacchini, M. (2022). Construction of dead-beat switched automata: application to cryptography. In *2022 10th International Conference on Systems and Control (ICSC)*, pages 1286–1293. (Cited on page 25.)

- [Boyd et al., 1994] Boyd, S., El Ghaoui, L., Feron, E., and Balakrishnan, V. (1994). *Linear Matrix Inequalities in system and control theory*. SIAM. (Cited on pages 35 and 48.)
- [Branicky et al., 1998] Branicky, M. S., Borkar, V. S., and Mitter, S. K. (1998). A unified framework for hybrid control: model and optimal control theory. *IEEE Transactions on Automatic Control*, 43:31–45. (Cited on page 33.)
- [Briat, 2013] Briat, C. (2013). Convex conditions for robust stability analysis and stabilization of linear aperiodic impulsive and sampled-data systems under dwell-time constraints. *Automatica*, 49(11):3449–3457. (Cited on page 83.)
- [Brogi et al., 2017] Brogi, E., Cyr, S., Kazan, R., Giunta, F., and Hemmerling, T. M. (2017). Clinical Performance and Safety of Closed-Loop Systems: A Systematic Review and Meta-analysis of Randomized Controlled Trials. *Anesthesia & Analgesia*, 124(2):446–455. (Cited on page 106.)
- [Bullo et al., 2009] Bullo, F., Cortés, J., and Martinez, S. (2009). *Distributed Control of Robotic Networks. A Mathematical Approach to Motion Coordination Algorithms*. Princeton University Press. (Cited on pages 10 and 33.)
- [Camacho and Alba, 2013] Camacho, E. F. and Alba, C. B. (2013). *Model predictive control*. Springer science & business media. (Cited on page 7.)
- [Camacho and Bordóns, 2004] Camacho, E. F. and Bordóns, C. (2004). *Model Predictive Control*. Springer-Verlag. (Cited on page 27.)
- [Cannon et al., 2011] Cannon, M., Kouvaritakis, B., Rakovic, S. V., and Cheng, Q. (2011). Stochastic tubes in model predictive control with probabilistic constraints. *IEEE Transactions on Automatic Control*, 56(1):194–200. (Cited on pages 28, 47 and 102.)
- [Chaouach et al., 2022] Chaouach, L. M., Fiacchini, M., and Alamo, T. (2022). Stochastic model predictive control for linear systems affected by correlated disturbances. In *10th IFAC Symposium on Robust Control Design ROCOND 2022*. (Cited on pages 8 and 29.)
- [Chareyron and Alamir, 2009] Chareyron, S. and Alamir, M. (2009). Mixed immunotherapy and chemotherapy of tumors: Feedback design and model updating schemes. *Journal of Theoretical Biology*, 45:444–454. (Cited on page 29.)
- [Chatterjee and Liberzon, 2006] Chatterjee, D. and Liberzon, D. (2006). Stability analysis of deterministic and stochastic switched systems via a comparison principle and multiple lyapunov functions. *SIAM Journal on Control and Optimization*, 45(1):174–206. (Cited on page 103.)
- [Chatzikokolakis et al., 2014] Chatzikokolakis, K., Palamidessi, C., and Stronati, M. (2014). A predictive differentially-private mechanism for mobility traces. In *International Symposium on Privacy Enhancing Technologies Symposium*, pages 21–41. Springer. (Cited on page 112.)
- [Chatzikokolakis et al., 2015] Chatzikokolakis, K., Palamidessi, C., and Stronati, M. (2015). Constructing elastic distinguishability metrics for location privacy. In *PETS*, volume 2015, pages 156–170. (Cited on page 112.)
- [Chen, 1984] Chen, C. T. (1984). *Linear System Theory and Design*. Oxford Series in Electrical and Computer Engineering. (Cited on page 32.)
- [Cloosterman et al., 2009] Cloosterman, M., Wouw, N. V. D., Heemels, W., and Nijmeijer, H. (2009). Stability of networked control systems with uncertain time-varying delays. *IEEE Transactions on Automatic Control*, 54(7):1575–1580. (Cited on pages 83 and 91.)
- [Colaneri, 2009] Colaneri, P. (2009). Dwell time analysis of deterministic and stochastic switched systems. *European Journal of Control*, 15(3-4):228–248. (Cited on page 103.)
- [Collins and Skelton, 1987] Collins, E. and Skelton, R. (1987). A theory of state covariance assignment for discrete systems. *IEEE Transactions on Automatic Control*, 32(1):35–41. (Cited on page 104.)
- [Copot, 2020] Copot, D. (2020). *Automated Drug Delivery in Anesthesia*. Academic Press. (Cited on page 106.)

- [da Silva Moreira et al., 2020a] da Silva Moreira, L., Besançon, G., Ferrante, F., Fiacchini, M., and Roustan, H. (2020a). Model based approach for online monitoring of aluminum production process. In *TMS Annual Meeting*. (Cited on pages 10, 11 and 31.)
- [da Silva Moreira et al., 2020b] da Silva Moreira, L. J., Fiacchini, M., Besançon, G., Ferrante, F., and Roustan, H. (2020b). State affine modeling and observer design for hall-héroult process. *IFAC-PapersOnLine*, 53(2):12020–12025. (Cited on page 10.)
- [da Silva Moreira et al., 2020c] da Silva Moreira, L. J., Fiacchini, M., Besançon, G., Ferrante, F., and Roustan, H. (2020c). State affine modeling and observer design for hall-héroult process. *IFAC-PapersOnLine*, 53(2):12020–12025. (Cited on pages 10, 11 and 31.)
- [da Silva Moreira et al., 2022] da Silva Moreira, L. J., Fiacchini, M., Besançon, G., Ferrante, F., and Roustan, H. (2022). Modeling and observer design for aluminum manufacturing. *European Journal of Control*, 64:100611. (Cited on pages 10, 12 and 31.)
- [Daafouz et al., 2002] Daafouz, J., Riedinger, P., and Iung, C. (2002). Stability analysis and control synthesis for switched systems: A switched Lyapunov function approach. *IEEE Transactions on Automatic Control*, 47:1883–1887. (Cited on pages 24 and 51.)
- [Darouach, 2000] Darouach, M. (2000). Existence and design of functional observers for linear systems. *IEEE Transactions on Automatic Control*, 45(5):940–943. (Cited on page 32.)
- [Darup and Mönnigmann, 2014] Darup, M. S. and Mönnigmann, M. (2014). On general relations between null-controllable and controlled invariant sets for linear constrained systems. In *2014 IEEE 53rd Conference on Decision and Control (CDC)*, pages 6323–6328. (Cited on page 35.)
- [Deaecto and Geromel, 2018] Deaecto, G. S. and Geromel, J. C. (2018). Stability and performance of discrete-time switched linear systems. *Systems & Control Letters*, 118:1–7. (Cited on page 52.)
- [Deaecto et al., 2011] Deaecto, G. S., Geromel, J. C., and Daafouz, J. (2011). Dynamic output feedback H_∞ control of switched linear systems. *Automatica*, 47(8):1713–1720. (Cited on page 78.)
- [Deaecto et al., 2015] Deaecto, G. S., Souza, M., and Geromel, J. C. (2015). Discrete-time switched linear systems state feedback design with application to networked control. *IEEE Transactions on Automatic Control*, 60(3):877–881. (Cited on page 78.)
- [Denardi Huff et al., 2021] Denardi Huff, D., Fiacchini, M., and Gomes da Silva Jr., J. M. (2021). Stabilization of aperiodic sampled-data linear systems with input constraints: a low complexity polyhedral approach. In *2021 60th IEEE Conference on Decision and Control (CDC)*, pages 6099–6104. (Cited on pages 11 and 84.)
- [Denardi Huff et al., 2022] Denardi Huff, D., Fiacchini, M., and Gomes da Silva Jr., J. M. (2022). Necessary and sufficient convex condition for the stabilization of linear sampled-data systems under poisson sampling process. *IEEE Control Systems Letters*, 6:3403–3408. (Cited on pages 8 and 105.)
- [Denardi Huff et al., 2022] Denardi Huff, D., Fiacchini, M., and Gomes da Silva Jr., J. M. (2022). Polyhedral estimates of the region of attraction of the origin of linear systems under aperiodic sampling and input saturation. *Automatica*, 144:110490. (Cited on pages 8, 11, 26, 84, 94, 95 and 96.)
- [Denardi Huff et al., 2022a] Denardi Huff, D., Fiacchini, M., and Gomes da Silva Jr., J. M. (2022a). Polyhedral regions of stability for aperiodic sampled-data linear control systems with saturating inputs. *IEEE Control Systems Letters*, 6:241–246. (Cited on pages 8, 11, 26, 84, 92, 93, 96, 98 and 99.)
- [Denardi Huff et al., 2022b] Denardi Huff, D., Fiacchini, M., and Gomes da Silva Jr., J. M. (2022b). Stability and stabilization of aperiodic sampled-data systems subject to control input saturation: A set invariant approach. *IEEE Transactions on Automatic Control*, 67(3):1423–1429. (Cited on pages 8, 11, 26, 84, 86, 88, 92, 97, 98 and 99.)
- [DePillis et al., 2005] DePillis, L. G., Gu, W., and Radunskaya, A. E. (2005). Mixed immunotherapy and chemotherapy of tumor: Modeling, application and biological interpretations. *Journal of Theoretical Biology*, 38:841–862. (Cited on page 29.)

- [DePillis and Radunskaya, 2005] DePillis, L. G. and Radunskaya, A. E. (2005). A mathematical tumor model with immune resistance and drug therapy: An optimal control approach. *Journal of Theoretical Medicine*, 3:79–100. (Cited on page 29.)
- [d’Onofrio et al., 2009] d’Onofrio, A., Ledzewicz, U., Maurer, H., and Schättler, H. (2009). On optimal delivery of combination therapy for tumors. *Mathematical biosciences*, 222(1):13–26. (Cited on pages 9 and 29.)
- [Dwork, 2006] Dwork, C. (2006). Differential Privacy. In *Automata, Languages and Programming*, volume 4052 of *Lecture Notes in Computer Science*, pages 1–12. Springer Berlin Heidelberg. (Cited on page 111.)
- [Eleveld et al., 2018] Eleveld, D. J., Colin, P., Absalom, A. R., and Struys, M. M. R. F. (2018). Pharmacokinetic–pharmacodynamic model for propofol for broad application in anaesthesia and sedation. *British Journal of Anaesthesia*, 120(5):942–959. (Cited on page 107.)
- [Eleveld et al., 2017] Eleveld, D. J., Proost, J. H., Vereecke, H., Absalom, A. R., Olofsen, E., Vuyk, J., and Struys, M. (2017). An Allometric Model of Remifentanyl Pharmacokinetics and Pharmacodynamics. *Anesthesiology*, 126(6):1005–1018. (Cited on page 107.)
- [Ergun et al., 2003] Ergun, A., Camphausen, K., and Wein, L. M. (2003). Optimal scheduling of radiotherapy and angiogenic inhibitors. *Bulletin of mathematical biology*, 65(3):407–424. (Cited on pages 9 and 29.)
- [Farina et al., 2013] Farina, M., Giulioni, L., Magni, L., and Scattolini, R. (2013). A probabilistic approach to model predictive control. In *52nd IEEE Conference on Decision and Control*, pages 7734–7739. IEEE. (Cited on page 103.)
- [Farina et al., 2015] Farina, M., Giulioni, L., Magni, L., and Scattolini, R. (2015). An approach to output-feedback MPC of stochastic linear discrete-time systems. *Automatica*, 55:140–149. (Cited on pages 28 and 102.)
- [Farina et al., 2016] Farina, M., Giulioni, L., and Scattolini, R. (2016). Stochastic linear model predictive control with chance constraints—a review. *Journal of Process Control*, 44:53–67. (Cited on pages 28, 102 and 103.)
- [Feng et al., 2011] Feng, W., Tian, J., and Zhao, P. (2011). Stability analysis of switched stochastic systems. *Automatica*, 47(1):148–157. (Cited on page 103.)
- [Ferrante et al., 2016] Ferrante, F., Gouaisbaut, F., Sanfelice, R. G., and Tarbouriech, S. (2016). State estimation of linear systems in the presence of sporadic measurements. *Automatica*, 73:101–109. (Cited on page 105.)
- [Fiacchini, 2021] Fiacchini, M. (2021). Yet another computation-oriented necessary and sufficient condition for stabilizability of switched linear systems. *IEEE Transactions on Automatic Control*. (Cited on pages 8, 24, 25 and 52.)
- [Fiacchini, 2010] Fiacchini, M. (January 2010). *Convex difference inclusions for systems analysis and design*. PhD thesis, Universidad de Sevilla, Spain. (Cited on page 27.)
- [Fiacchini and Almir, 2017a] Fiacchini, M. and Almir, M. (2017a). Computing control invariant sets is easy. *arXiv:1708.04797*. (Cited on pages 7 and 36.)
- [Fiacchini and Almir, 2017b] Fiacchini, M. and Almir, M. (2017b). Computing control invariant sets is easy. *arXiv preprint arXiv:1708.04797*. (Cited on pages 27 and 36.)
- [Fiacchini and Almir, 2018a] Fiacchini, M. and Almir, M. (2018a). Computing control invariant sets in high dimension is easy. *arXiv:1810.10372*. (Cited on pages 7 and 36.)
- [Fiacchini and Almir, 2018b] Fiacchini, M. and Almir, M. (2018b). Computing control invariant sets in high dimension is easy. *arXiv preprint arXiv:1810.10372*. (Cited on page 27.)
- [Fiacchini and Almir, 2021] Fiacchini, M. and Almir, M. (2021). The ockham’s razor applied to covid-19 model fitting french data. *Annual Reviews in Control*, 51:500–510. (Cited on page 32.)
- [Fiacchini and Alamo, 2020] Fiacchini, M. and Alamo, T. (2020). Probabilistic reachable and invariant sets for linear systems with correlated disturbance. *arXiv preprint arXiv:2004.06960*. (Cited on pages 8 and 103.)

- [Fiacchini and Alamo, 2021] Fiacchini, M. and Alamo, T. (2021). Probabilistic reachable and invariant sets for linear systems with correlated disturbance. *Automatica*, 132:109808. (Cited on pages 29 and 36.)
- [Fiacchini and Alamo, 2022] Fiacchini, M. and Alamo, T. (2022). Covariance control for discrete-time stochastic switched linear systems. *IFAC-PapersOnLine*, 55(25):139–144. (Cited on page 104.)
- [Fiacchini et al., 2010a] Fiacchini, M., Alamo, T., and Camacho, E. F. (2010a). On the computation of convex robust control invariant sets for nonlinear systems. *Automatica*, 46(8):1334–1338. (Cited on pages 27 and 35.)
- [Fiacchini et al., 2010b] Fiacchini, M., Alamo, T., and Camacho, E. F. (2010b). On the computation of convex robust control invariant sets for nonlinear systems. *Automatica*, 46(8):1334–1338. (Cited on page 36.)
- [Fiacchini et al., 2012a] Fiacchini, M., Alamo, T., and Camacho, E. F. (2012a). Invariant sets computation for convex difference inclusions systems. *Systems & Control Letters*, 61:819–826. (Cited on pages 27 and 35.)
- [Fiacchini et al., 2014a] Fiacchini, M., Girard, A., and Jungers, M. (2014a). On stabilizability conditions for discrete-time switched linear systems. In *Proceedings of the 53th IEEE Conference on Decision and Control and European Control Conference*, Los Angeles, CA, USA. (Cited on pages 8 and 33.)
- [Fiacchini et al., 2016a] Fiacchini, M., Girard, A., and Jungers, M. (2016a). On the stabilizability of discrete-time switched linear systems: Novel conditions and comparisons. *IEEE Transactions on Automatic Control*, 61(5):1181–1193. (Cited on pages 8, 24, 25, 52, 61, 65, 66, 70, 73, 77, 78 and 79.)
- [Fiacchini and Gomes da Silva Jr., 2018] Fiacchini, M. and Gomes da Silva Jr., J. M. (2018). Stability of sampled-data control systems under aperiodic sampling and input saturation. In *Proceedings of the 57th IEEE Conference on Decision and Control*, Miami, USA. (Cited on pages 8, 11, 26, 83 and 84.)
- [Fiacchini and Gomes da Silva Jr., 2018] Fiacchini, M. and Gomes da Silva Jr., J. M. (2018). Stability of sampled-data control systems under aperiodic sampling and input saturation. In *2018 IEEE Conference on Decision and Control (CDC)*, pages 6644–6649. (Cited on pages 84, 90, 94, 97, 98 and 99.)
- [Fiacchini and Jungers, 2013] Fiacchini, M. and Jungers, M. (2013). Necessary and sufficient condition for stabilizability of discrete-time linear switched systems: a set-theory approach. In *Proceedings of the IFAC Joint conference, Symposium System Structure and Control*. (Cited on pages 24 and 52.)
- [Fiacchini and Jungers, 2014] Fiacchini, M. and Jungers, M. (2014). Necessary and sufficient condition for stabilizability of discrete-time linear switched systems: A set-theory approach. *Automatica*, 50(1):75–83. (Cited on pages 8, 24, 25, 52, 55, 65, 66, 67 and 70.)
- [Fiacchini et al., 2016b] Fiacchini, M., Jungers, M., and Girard, A. (2016b). Exponential stabilization of language constrained discrete-time switched linear systems: A geometrical approach. In *2016 European Control Conference (ECC)*, pages 2035–2040. (Cited on pages 8, 24 and 52.)
- [Fiacchini et al., 2018] Fiacchini, M., Jungers, M., and Girard, A. (2018). Stabilization and control lyapunov functions for language constrained discrete-time switched linear systems. *Automatica*, 93:64–74. (Cited on pages 8, 24 and 52.)
- [Fiacchini and Millerioux, 2012] Fiacchini, M. and Millerioux, G. (2012). Fast input-free observers for lpv discrete-time systems. In *Proceedings of the 51th IEEE Conference on Decision and Control and European Control Conference*, Maui, Hawaii, USA. (Cited on page 32.)
- [Fiacchini and Millerioux, 2013] Fiacchini, M. and Millerioux, G. (2013). Dead-beat functional observers for discrete-time lpv systems with unknown inputs. *IEEE Transactions on Automatic Control*, 58:3230–3235. (Cited on page 32.)

- [Fiacchini and Millérioux, 2017] Fiacchini, M. and Millérioux, G. (2017). Dead-beat stabilizability of autonomous switched linear discrete-time systems. In *20th IFAC World Congress, IFAC 2017*. (Cited on pages 8, 24 and 25.)
- [Fiacchini and Millérioux, 2018] Fiacchini, M. and Millérioux, G. (2018). Dead-beat stabilizability of discrete-time switched linear systems: algorithms and applications. *IEEE Transactions on Automatic Control*, 64(9):3839–3845. (Cited on pages 8 and 25.)
- [Fiacchini and Morărescu, 2016] Fiacchini, M. and Morărescu, I.-C. (2016). Constructive necessary and sufficient condition for the stability of quasi-periodic linear impulsive systems. *IEEE Transactions on Automatic Control*, 61(9):2512–2517. (Cited on pages 83, 91, 92, 95 and 98.)
- [Fiacchini and Morărescu, 2012] Fiacchini, M. and Morărescu, I.-C. (2012). Set theory based condition in LMI form for network topology preservation for decentralized control. In *Proc. of the 51st IEEE Conference on Decision and Control (CDC)*, pages 6229–6234. (Cited on pages 10 and 33.)
- [Fiacchini and Morărescu, 2014a] Fiacchini, M. and Morărescu, I.-C. (2014a). Convex conditions on decentralized control for graph topology preservation. *IEEE Transactions on Automatic Control*, 59:1640–1645. (Cited on pages 10 and 33.)
- [Fiacchini and Morărescu, 2014b] Fiacchini, M. and Morărescu, I.-C. (2014b). Set theory conditions for stability of linear impulsive systems. In *Proceedings of the 40th IEEE Conference on Decision and Control*, Los Angeles, CA, USA. (Cited on page 8.)
- [Fiacchini et al., 2015] Fiacchini, M., Prieur, C., and Tarbouriech, S. (2015). On the computation of set-induced control lyapunov functions for continuous-time systems. *SIAM Journal on Control and Optimization*, 53(3):1305–1327. (Cited on page 27.)
- [Fiacchini et al., 2016c] Fiacchini, M., Queinnec, I., Tarbouriech, S., and Mazerolles, M. (2016c). Invariant based control of induction and maintenance phases for anesthesia. In *The 6th IFAC Conference on Foundations of Systems Biology in Engineering (FOSBE 2016)*. (Cited on page 9.)
- [Fiacchini and Tarbouriech, 2017] Fiacchini, M. and Tarbouriech, S. (2017). Control co-design for discrete-time switched linear systems. *Automatica*, 82:181–186. (Cited on pages 8, 24, 25 and 52.)
- [Fiacchini et al., 2011] Fiacchini, M., Tarbouriech, S., and Prieur, C. (2011). Polytopic control invariant sets for continuous-time systems: A viability theory approach. In *Proceedings of the American Control Conference, 2011. ACC'11*, pages 1218–1223, San Francisco, CA. (Cited on page 33.)
- [Fiacchini et al., 2012b] Fiacchini, M., Tarbouriech, S., and Prieur, C. (2012b). Quadratic stability for hybrid systems with nested saturations. *IEEE Transactions on Automatic Control*, 57:1832–1838. (Cited on pages 24 and 52.)
- [Fiacchini et al., 2012c] Fiacchini, M., Tarbouriech, S., and Prieur, C. (2012c). Quadratic stability for hybrid systems with nested saturations. *IEEE Transactions on Automatic Control*. (Cited on page 33.)
- [Fiacchini et al., 2014b] Fiacchini, M., Tarbouriech, S., and Prieur, C. (2014b). *Hybrid systems with constraints*, chapter Exponential Stability for Hybrid Systems with Saturations, pages 179–212. ISTE Ltd and John Wiley & Sons Inc. (Cited on page 33.)
- [Fiacchini, M.,] Fiacchini, M. <http://www.gipsa-lab.fr/~mirko.fiacchini/NSCswitch>. (Cited on page 73.)
- [Fichera et al., 2012a] Fichera, F., Prieur, C., Tarbouriech, S., and Zaccarian, L. (2012a). Improving the performance of linear systems by adding a hybrid loop: the output feedback case. In *Proceedings of the American Control Conference 2012*, Montréal, Canada. (Cited on page 33.)
- [Fichera et al., 2012b] Fichera, F., Prieur, C., Tarbouriech, S., and Zaccarian, L. (2012b). On hybrid state-feedback loops based on a dwell-time logic. In *Proceedings of the 4th IFAC conference on Analysis and Design of Hybrid Systems, ADHS'12*, Eindhoven, Netherlands. (Cited on page 33.)

- [Fridman, 2010] Fridman, E. (2010). A refined input delay approach to sampled-data control. *Automatica*, 46(2):421–427. (Cited on page 83.)
- [Fujioka, 2009] Fujioka, H. (2009). A discrete-time approach to stability analysis of systems with aperiodic sample-and-hold devices. *IEEE Transactions on Automatic Control*, 54(10):2440–2445. (Cited on pages 83 and 91.)
- [Fujioka and Oishi, 2011] Fujioka, H. and Oishi, Y. (2011). A switched Lyapunov function approach to stability analysis of non-uniformly sampled-data systems with robust LMI techniques. In *8th Asian Control Conference (ASCC)*, pages 1487–1491. (Cited on pages 83 and 91.)
- [Gambs et al., 2011] Gambs, S., Killijian, M.-O., and del Prado Cortez, M. N. (2011). Show Me How You Move and I Will Tell You Who You Are. *Transactions on Data Privacy*, 4(2):103–126. (Cited on page 111.)
- [Geromel and Colaneri, 2006a] Geromel, J. C. and Colaneri, P. (2006a). Stability and stabilization of continuous-time switched linear systems. *SIAM J. Control Optim.*, 45(5):1915–1930. (Cited on pages 51, 60 and 70.)
- [Geromel and Colaneri, 2006b] Geromel, J. C. and Colaneri, P. (2006b). Stability and stabilization of discrete-time switched systems. *International Journal of Control*, 79(7):719–728. (Cited on pages 24, 51, 60, 61, 67, 70 and 78.)
- [Géron, 2019] Géron, A. (2019). *Hands-on Machine Learning with Scikit-Learn, Keras, and TensorFlow: Concepts, Tools, and Techniques to Build Intelligent Systems*. O’Reilly Media, Inc. (Cited on pages 103 and 111.)
- [Gevertz, 2012] Gevertz, J. (2012). Optimization of vascular-targeting drugs in a computational model of tumor growth. *Physical Review E*, 85(4):041914. (Cited on page 29.)
- [Gilbert and Tan, 1991] Gilbert, E. G. and Tan, K. (1991). Linear systems with state and control constraints: The theory and application of maximal output admissible sets. *IEEE Transactions on Automatic Control*, 36:1008–1020. (Cited on pages 7 and 23.)
- [Goebel et al., 2004] Goebel, R., Hespanha, J. P., Teel, A. R., Cai, C., and Sanfelice, R. (2004). Hybrid Systems: generalized solutions and robust stability. In *Proceedings of the IFAC Symposium on Nonlinear Control Systems*, pages 1–12, Stuttgart, Germany. (Cited on page 33.)
- [Goebel et al., 2009] Goebel, R., Sanfelice, R., and Teel, A. R. (2009). Hybrid dynamical systems. *IEEE Control Systems Magazine*, 29(2):28–93. (Cited on page 33.)
- [Goebel et al., 2012] Goebel, R., Sanfelice, R., and Teel, A. R. (2012). *Hybrid dynamical systems*. Princeton University Press. (Cited on page 33.)
- [Gomes da Silva Jr. and Tarbouriech, 1999] Gomes da Silva Jr., J. and Tarbouriech, S. (1999). Polyhedral regions of local stability for linear discrete-time systems with saturating controls. *IEEE Transactions on Automatic Control*, 44(11):2081–2085. (Cited on page 96.)
- [Gomes da Silva Jr. et al., 2016] Gomes da Silva Jr., J. M., Queinnec, I., Seuret, A., and Tarbouriech, S. (2016). Regional stability analysis of discrete-time dynamic output feedback under aperiodic sampling and input saturation. *IEEE Transactions on Automatic Control*, 61(12):4176–4182. (Cited on page 83.)
- [Gomes da Silva Jr. and Tarbouriech, 2001] Gomes da Silva Jr., J. M. and Tarbouriech, S. (2001). Local stabilization of discrete-time linear systems with saturating controls: An LMI-based approach. *IEEE Transactions on Automatic Control*, 46:119–125. (Cited on pages 33 and 88.)
- [Gomes da Silva Jr. and Tarbouriech, 2005] Gomes da Silva Jr., J. M. and Tarbouriech, S. (2005). Anti-windup design with guaranteed region of stability: an LMI-based approach. *IEEE Transactions on Automatic Control*, 50(1):106–111. (Cited on page 86.)
- [Gonzalez et al., 2010] Gonzalez, R., Fiacchini, M., Alamo, T., Guzman, J. L., and Rodriguez, F. (2010). Adaptive control for a mobile robot under slip conditions using an lmi-based approach. *European Journal of Control*, 16(2):144–155. (Cited on page 28.)

- [Gonzalez et al., 2011] Gonzalez, R., Fiacchini, M., Alamo, T., Guzmán, J. L., and Rodríguez, F. (2011). Online robust tube-based mpc for time-varying systems: A practical approach. *International Journal of Control*, 84(6):1157–1170. (Cited on page 28.)
- [González et al., 2011] González, R., Fiacchini, M., Guzmán, J. L., Álamo, T., and Rodríguez, F. (2011). Robust tube-based predictive control for mobile robots in off-road conditions. *Robotics and Autonomous Systems*, 59(10):711–726. (Cited on page 28.)
- [Gonzalez et al., 2018] Gonzalez, R., Fiacchini, M., and Iagnemma, K. (2018). Slippage prediction for off-road mobile robots via machine learning regression and proprioceptive sensing. *Robotics and Autonomous Systems*, 105:85–93. (Cited on pages 10 and 32.)
- [Google Play, 2022] Google Play (2022). Travel & Local - Android Apps on Google. (Cited on page 111.)
- [Grjotheim, 1982] Grjotheim, K. (1982). *Aluminium electrolysis: fundamentals of the Hall-Héroult process*. Aluminium-Verlag. (Cited on pages 9 and 30.)
- [Gutman and Cwikel, 1986a] Gutman, P. and Cwikel, M. (1986a). Admissible sets and feedback control for discrete-time linear dynamical systems with bounded control and states. *IEEE Transactions on Automatic Control*, AC-31(4):373–376. (Cited on pages 7 and 23.)
- [Gutman and Cwikel, 1986b] Gutman, P. and Cwikel, M. (1986b). Admissible sets and feedback control for discrete-time linear dynamical systems with bounded control and states. *IEEE Transactions on Automatic Control*, AC-31(4):373–376. (Cited on pages 27 and 35.)
- [Gutman and Cwikel, 1987] Gutman, P. and Cwikel, M. (1987). An algorithm to find maximal state constraint sets for discrete-time linear dynamical systems with bounded controls and states. *IEEE Transactions on Automatic Control*, AC-32(3):251–254. (Cited on pages 7 and 23.)
- [Hahnfeldt et al., 1999] Hahnfeldt, P., Panigraphy, D., Folkman, J., and Hlatky, L. (1999). Tumor development under angiogenic signaling: a dynamical theory to tumor growth, treatment, response and postvascular dormancy. *Cancer Research*, 59:4770–4775. (Cited on pages 9 and 29.)
- [Heemels et al., 2016a] Heemels, W., Kundu, A., and Daafouz, J. (2016a). On Lyapunov-Metzler inequalities and S-procedure characterisations for the stabilisation of switched linear systems. *IEEE Transactions on Automatic Control*, PP(99):1–1. (Cited on page 24.)
- [Heemels et al., 2016b] Heemels, W. P. M. H., Kundu, A., and Daafouz, J. (2016b). On Lyapunov-Metzler inequalities and S-procedure characterizations for the stabilization of switched linear systems. *IEEE Transactions on Automatic Control*, 62(9):4593–4597. (Cited on page 52.)
- [Henrion and Korda, 2014] Henrion, D. and Korda, M. (2014). Convex computation of the region of attraction of polynomial control systems. *IEEE Transactions on Automatic Control*, 59(2):297–312. (Cited on pages 23 and 35.)
- [Herceg et al., 2013] Herceg, M., Kvasnica, M., Jones, C., and Morari, M. (2013). Multi-Parametric Toolbox 3.0. In *Proc. of the European Control Conference*, pages 502–510, Zürich, Switzerland. (Cited on page 95.)
- [Hespanha et al., 2007] Hespanha, J. P., Naghshtabrizi, P., and Xu, Y. (2007). A survey of recent results in networked control systems. *Proceedings of the IEEE*, 95(1):138–162. (Cited on page 83.)
- [Hetel et al., 2013] Hetel, L., Daafouz, J., Tarbouriech, S., and Prieur, C. (2013). Stabilization of linear impulsive systems through a nearly-periodic reset. *Nonlinear Analysis: Hybrid Systems*, 7(1):4–15. (Cited on page 85.)
- [Hetel et al., 2017] Hetel, L., Fiter, C., Omran, H., Seuret, A., Fridman, E., Richard, J. P., and Niculescu, S. I. (2017). Recent developments on the stability of systems with aperiodic sampling: An overview. *Automatica*, 76:309 – 335. (Cited on pages 26 and 83.)
- [Hewing et al., 2018] Hewing, L., Carron, A., Wabersich, K. P., and Zeilinger, M. N. (2018). On a correspondence between probabilistic and robust invariant sets for linear systems. In *2018 European Control Conference (ECC)*, pages 1642–1647. IEEE. (Cited on pages 36, 47, 48 and 103.)

- [Hewing et al., 2020] Hewing, L., Wabersich, K. P., and Zeilinger, M. N. (2020). Recursively feasible stochastic model predictive control using indirect feedback. *Automatica*, 119:109095. (Cited on page 103.)
- [Hewing and Zeilinger, 2018] Hewing, L. and Zeilinger, M. N. (2018). Stochastic model predictive control for linear systems using probabilistic reachable sets. In *2018 IEEE Conference on Decision and Control (CDC)*, pages 5182–5188. (Cited on pages 28, 47, 102 and 103.)
- [Hewing and Zeilinger, 2019] Hewing, L. and Zeilinger, M. N. (2019). Scenario-based probabilistic reachable sets for recursively feasible stochastic model predictive control. *IEEE Control Systems Letters*, 4(2):450–455. (Cited on pages 36 and 103.)
- [Hosseini et al., 2019a] Hosseini, I., Fiacchini, M., Karimaghaee, P., and Khayatian, A. (2019a). Optimal reset unknown input observer design for fault and state estimation in a class of nonlinear uncertain systems. *Journal of the Franklin Institute*. (Cited on pages 10 and 34.)
- [Hosseini et al., 2019b] Hosseini, I., Khayatian, A., Karimaghaee, P., Fiacchini, M., and Navarro Davo, M. (2019b). Lmi-based reset unknown input observer for state estimation of linear uncertain systems. *IET Control Theory & Applications*, 13(12):1872–1881. (Cited on pages 10 and 34.)
- [Hsieh and Skelton, 1990] Hsieh, C. and Skelton, R. E. (1990). All covariance controllers for linear discrete-time systems. *IEEE transactions on automatic control*, 35(8):908–915. (Cited on page 104.)
- [Hu and Lin, 2002] Hu, T. and Lin, Z. (2002). Exact characterization of invariant ellipsoids for single input linear systems subject to actuator saturation. *IEEE Transactions on Automatic Control*, 47(1):164–169. (Cited on pages 8 and 33.)
- [Hu et al., 2002] Hu, T., Lin, Z., and Chen, B. M. (2002). Analysis and design for discrete-time linear systems subject to actuator saturation. *Systems & Control Letters*, 45(2):97 – 112. (Cited on page 33.)
- [Ionescu et al., 2008] Ionescu, C., De Keyser, R., Torrico, B., De Smet, T., Struys, M., and Normey-Rico, J. (2008). Robust predictive control strategy applied for propofol dosing using bis as a controlled variable during anesthesia. *IEEE Transactions on Biomedical Engineering*, 55(9):2161–2170. (Cited on pages 9 and 30.)
- [Jaap et al., 2020] Jaap, V., Elske, S., and Marije, R. (2020). Intravenous Anesthetics. In *Miller’s Anesthesia*, pages 748–799. Elsevier, ninth edition. (Cited on page 106.)
- [Jadbabaie et al., 2003] Jadbabaie, A., Lin, J., and Morse, A. (2003). Coordination of groups of mobile autonomous agents using nearest neighbor rules. *IEEE Transactions on Automatic Control*, 48:988–1001. (Cited on page 33.)
- [Jakobsen et al., 2001] Jakobsen, S., Hestetun, K., Hovd, M., and Solberg, I. (2001). Estimating alumina concentration distribution in aluminium electrolysis cells. *IFAC Proceedings Volumes*, 34(18):303–308. (Cited on pages 9 and 31.)
- [Jiang et al., 2021] Jiang, H., Li, J., Zhao, P., Zeng, F., Xiao, Z., and Iyengar, A. (2021). Location privacy-preserving mechanisms in location-based services: A comprehensive survey. *ACM Computing Surveys*, 54(1):1–36. (Cited on page 111.)
- [Jones et al., 2004] Jones, C., Kerrigan, E. C., and Maciejowski, J. (2004). Equality set projection: A new algorithm for the projection of polytopes in halfspace representation. Technical report, Cambridge University Engineering Dept. (Cited on page 38.)
- [Jones and Peet, 2021a] Jones, M. and Peet, M. M. (2021a). A converse sum of squares lyapunov function for outer approximation of minimal attractor sets of nonlinear systems. (Cited on pages 23 and 35.)
- [Jones and Peet, 2021b] Jones, M. and Peet, M. M. (2021b). A generalization of bellman’s equation with application to path planning, obstacle avoidance and invariant set estimation. *Automatica*, 127:109510. (Cited on pages 23 and 35.)

- [Jove et al., 2019] Jove, E., Gonzalez-Cava, J. M., Casteleiro-Roca, J.-L., Quintián, H., Méndez-Pérez, J. A., and Calvo-Rolle, J. L. (2019). Anomaly Detection on Patients Undergoing General Anesthesia. In *International Joint Conference: 12th International Conference on Computational Intelligence in Security for Information Systems (CISIS 2019) and 10th International Conference on European Transnational Education (ICEUTE 2019)*. (Cited on page 109.)
- [Jungers et al., 2016] Jungers, M., Girard, A., and Fiacchini, M. (2016). Language constrained stabilization of discrete-time switched linear systems: a Lyapunov-Metzler inequalities approach. In *2016 IEEE 55th Conference on Decision and Control (CDC)*, pages 5539–5544. IEEE. (Cited on page 24.)
- [Jungers et al., 2018] Jungers, M., Girard, A., and Fiacchini, M. (2018). Language constrained stabilization of discrete-time switched linear systems: an LMI approach. In *IFAC Conference on Analysis and Design of Hybrid Systems (ADHS 2018)*, volume 51, pages 25–30. Elsevier. (Cited on page 24.)
- [Jungers, 2009a] Jungers, R. M. (2009a). *The Joint Spectral Radius: Theory and Applications*. Springer-Verlag., Berlin Heidelberg. (Cited on pages 24 and 51.)
- [Jungers, 2009b] Jungers, R. M. (2009b). *The Joint Spectral Radius: Theory and Applications*. Springer-Verlag., Berlin Heidelberg. (Cited on page 52.)
- [Jungers and Mason, 2017] Jungers, R. M. and Mason, P. (2017). On feedback stabilization of linear switched systems via switching signal control. *SIAM Journal on Control and Optimization*, 55(2):1179–1198. (Cited on pages 25, 52, 69, 72, 73 and 74.)
- [Kalandros, 2002] Kalandros, M. (2002). Covariance control for multisensor systems. *IEEE Transactions on Aerospace and Electronic Systems*, 38(4):1138–1157. (Cited on page 104.)
- [Kao and Fujioka, 2013] Kao, C.-Y. and Fujioka, H. (2013). On stability of systems with aperiodic sampling devices. *IEEE Transactions on Automatic Control*, 28(3):2085–2090. (Cited on pages 83 and 91.)
- [Karg et al., 2021] Karg, B., Alamo, T., and Lucia, S. (2021). Probabilistic performance validation of deep learning-based robust nmpc controllers. *International Journal of Robust and Nonlinear Control*, 31(18):8855–8876. (Cited on page 103.)
- [Keerthi and Gilbert, 1987] Keerthi, S. and Gilbert, E. (1987). Computation of minimum-time feedback control laws for discrete-time systems with state-control constraints. *IEEE Transactions on Automatic Control*, 32(5):432–435. (Cited on pages 27, 35 and 38.)
- [Kerrigan, 2001] Kerrigan, E. C. (2001). *Robust constraint satisfaction: Invariant sets and predictive control*. PhD thesis, Citeseer. (Cited on pages 27 and 35.)
- [Khaitan and McCalley, 2015] Khaitan, S. K. and McCalley, J. D. (2015). Design techniques and applications of cyberphysical systems: A survey. *IEEE Systems Journal*, 9(2):350–365. (Cited on page 104.)
- [Klett et al., 2020] Klett, C., Abate, M., Yoon, Y., Coogan, S., and Feron, E. (2020). Bounding the state covariance matrix for switched linear systems with noise. In *2020 American Control Conference (ACC)*, pages 2876–2881. IEEE. (Cited on page 104.)
- [Kofman et al., 2012] Kofman, E., De Doná, J. A., and Seron, M. M. (2012). Probabilistic set invariance and ultimate boundedness. *Automatica*, 48(10):2670–2676. (Cited on pages 36, 48 and 103.)
- [Kolmanovsky and Gilbert, 1998a] Kolmanovsky, I. and Gilbert, E. G. (1998a). Theory and computation of disturbance invariant sets for discrete-time linear systems. *Mathematical Problems in Engineering*, 4:317–367. (Cited on pages 7 and 23.)
- [Kolmanovsky and Gilbert, 1998b] Kolmanovsky, I. and Gilbert, E. G. (1998b). Theory and computation of disturbance invariant sets for discrete-time linear systems. *Mathematical Problems in Engineering*, 4:317–367. (Cited on page 36.)

- [Korda et al., 2014a] Korda, M., Gondhalekar, R., Oldewurtel, F., and Jones, C. N. (2014a). Stochastic mpc framework for controlling the average constraint violation. *IEEE Transactions on Automatic Control*, 59(7):1706–1721. (Cited on pages 28 and 102.)
- [Korda et al., 2014b] Korda, M., Henrion, D., and Jones, C. N. (2014b). Convex computation of the maximum controlled invariant set for polynomial control systems. *SIAM Journal on Control and Optimization*, 52(5):2944–2969. (Cited on pages 23 and 35.)
- [Koufogiannis and Pappas, 2016] Koufogiannis, F. and Pappas, G. J. (2016). Location-dependent privacy. In *Decision and Control (CDC), 2016 IEEE 55th Conference on*, pages 7586–7591. IEEE. (Cited on page 112.)
- [Kouvaritakis and Cannon, 2016] Kouvaritakis, B. and Cannon, M. (2016). Model predictive control. *Switzerland: Springer International Publishing*, 38. (Cited on pages 7, 27 and 103.)
- [Kouvaritakis et al., 2010] Kouvaritakis, B., Cannon, M., Rakovic, S. V., and Cheng, Q. (2010). Explicit use of probabilistic distributions in linear predictive control. (Cited on page 103.)
- [Kvasnica et al., 2004] Kvasnica, M., Grieder, P., and Baotić, M. (2004). Multi-Parametric Toolbox (MPT). (Cited on page 38.)
- [Lasserre, 1993] Lasserre, J. B. (1993). Reachable, controllable sets and stabilizing control of constrained linear systems. *Automatica*, 29(2):531–536. (Cited on page 35.)
- [Lavaei et al., 2020] Lavaei, A., Soudjani, S., and Zamani, M. (2020). Compositional abstraction-based synthesis for networks of stochastic switched systems. *Automatica*, 114:108827. (Cited on page 103.)
- [Ledzewicz et al., 2011] Ledzewicz, U., Maurer, H., Schättler, H., et al. (2011). Optimal and suboptimal protocols for a mathematical model for tumor anti-angiogenesis in combination with chemotherapy. *Mathematical Biosciences and Engineering*, 8(2):307–323. (Cited on page 29.)
- [Ledzewicz et al., 2008] Ledzewicz, U., Schättler, H., and d’Onofrio, A. (2008). Optimal control for combination therapy in cancer. In *47th IEEE Conference on Decision and Control*. (Cited on page 29.)
- [Lee and Dullerud, 2007] Lee, J. W. and Dullerud, G. E. (2007). Uniformly stabilizing sets of switching sequences for switched linear systems. *IEEE Transactions on Automatic Control*, 52:868–874. (Cited on pages 24 and 51.)
- [Lemos et al., 2014] Lemos, J. M., Caiado, D. V., Costa, B. A., Paz, L. A., Mendonça, T. F., Rabiço, R., Esteves, S., and Seabra, M. (2014). Robust control of maintenance-phase anesthesia. *IEEE Control Systems*, 34(6):24–38. (Cited on pages 9 and 30.)
- [Lesart, 2013] Lesart, A.-C. (November 2013). *Modélisation théorique du développement tumoral sous fenêtre dorsal*. PhD thesis, Université de Grenoble, France. (Cited on page 29.)
- [Lesart et al., 2012] Lesart, A.-C., van der Sanden, B., Hamard, L., Estève, F., and Stéphanou, A. (2012). On the importance of the submicrovascular network in a computational model of tumour growth. *Microvascular Research*, 84(2):188 – 204. (Cited on page 29.)
- [Liberzon, 2003] Liberzon, D. (2003). *Switching in Systems and Control*. Birkhauser, Boston, MA. (Cited on pages 8, 24, 51 and 60.)
- [Lin and Antsaklis, 2009] Lin, H. and Antsaklis, P. J. (2009). Stability and stabilizability of switched linear systems: a survey of recent results. *IEEE Transaction on Automatic Control*, 54(2):308–322. (Cited on pages 8, 24, 51, 53, 54 and 56.)
- [Liu and Fridman, 2012] Liu, K. and Fridman, E. (2012). Wirtinger’s inequality and Lyapunov-based sampled-data stabilization. *Automatica*, 48(1):102 – 108. (Cited on page 83.)
- [Loeb and Cannesson, 2017] Loeb, R. G. and Cannesson, M. (2017). Closed-Loop Anesthesia: Ready for Prime Time? *Anesthesia & Analgesia*, 124(2):381–382. (Cited on page 106.)
- [Löfberg, 2004] Löfberg, J. (2004). YALMIP : A Toolbox for Modeling and Optimization in MATLAB. In *Proceedings of the CACSD Conference*, Taipei, Taiwan. (Cited on page 41.)

- [Lombardi et al., 2012] Lombardi, W., Olaru, S., Niculescu, S.-I., and Hetel, L. (2012). A predictive control scheme for systems with variable time-delay. *International Journal of Control*, 85(7):915–932. (Cited on pages 83 and 91.)
- [Luenberger, 1966] Luenberger, D. (1966). Observers for multivariable systems. *IEEE Transactions on Automatic Control*, 11:190 – 197. (Cited on page 32.)
- [Maciag et al., 2022] Maciag, T. T., van Amsterdam, K., Ballast, A., Cnossen, F., and Struys, M. (2022). Machine learning in anesthesiology: Detecting adverse events in clinical practice. *Health Informatics Journal*, 28(3):14604582221112855. (Cited on page 109.)
- [Mammarella et al., 2020] Mammarella, M., Alamo, T., Lucia, S., and Dabbene, F. (2020). A probabilistic validation approach for penalty function design in stochastic model predictive control. *IFAC-PapersOnLine*, 53(2):11271–11276. 21st IFAC World Congress. (Cited on page 103.)
- [Manrique et al., 2013] Manrique, T., Fiacchini, M., Chambrion, T., and Millerioux, G. (2013). MPC for a low consumption electric vehicle with time-varying constraints. In *Proceedings of the 2013 IFAC joint conference, 5th Symposium on System Structure and Control*, Grenoble, France. (Cited on pages 7 and 28.)
- [Manrique et al., 2014] Manrique, T., Fiacchini, M., Chambrion, T., and Millerioux, G. (2014). MPC tracking under time-varying polytopic constraints for real-time applications. In *Proceedings of the 13th European Control Conference (ECC14)*, Strasbourg, France. (Cited on pages 7 and 28.)
- [Manrique et al., 2015] Manrique, T., Fiacchini, M., Chambrion, T., and Millerioux, G. (2015). MPC-based tracking for real-time systems subject to time-varying polytopic constraints. *Optimal Control Applications and Methods*, 37:708–729. (Cited on pages 7 and 28.)
- [Margaliot, 2006] Margaliot, M. (2006). Stability analysis of switched systems using variational principles: An introduction. *Automatica*, 42:2059–2077. (Cited on page 51.)
- [Marsh et al., 1991] Marsh, B., White, M., morton, N., and Kenny, G. N. C. (1991). Pharmacokinetic model Driven Infusion of Propofol in Children. *BJA: British Journal of Anaesthesia*, 67(1):41–48. (Cited on pages 106 and 107.)
- [Marsland, 2011] Marsland, S. (2011). *Machine Learning: An Algorithmic Perspective*. Chapman and Hall/CRC, New York. (Cited on pages 103 and 111.)
- [Matveev and Savkin, 2002] Matveev, A. and Savkin, A. V. (2002). Application of optimal control theory to analysis of cancer chemotherapy regimens. *Systems and Control Letters*, 46:311–321. (Cited on page 29.)
- [Mayne et al., 2000] Mayne, D., Rawlings, J., Rao, C., and Sokaert, P. (2000). Constrained model predictive control: Stability and optimality. *Automatica*, 36:789–814. (Cited on pages 7, 27 and 35.)
- [Mayne, 2018] Mayne, D. Q. (2018). Competing methods for robust and stochastic MPC. *IFAC-PapersOnLine*, 51(20):169–174. (Cited on pages 28 and 102.)
- [Mayne and Schroeder, 1997] Mayne, D. Q. and Schroeder, W. R. (1997). Robust time-optimal control of constrained linear systems. *Automatica*, 33(12):2103–2118. (Cited on pages 27 and 35.)
- [Mesbah, 2016] Mesbah, A. (2016). Stochastic model predictive control: An overview and perspectives for future research. *IEEE Control Systems Magazine*, 36(6):30–44. (Cited on pages 28, 36 and 102.)
- [Messaoud et al., 2010] Messaoud, R. B., Zanzouri, N., and Ksouri, M. (2010). Local feedback unknown input observer for nonlinear systems. *International Journal of Innovative Computing, Information and Control*, 8(2):1145–1154. (Cited on page 32.)
- [Minto et al., 1997] Minto, C. F., Schnider, T. W., Egan, T. D., Youngs, E., Lemmens, H. J. M., Gambus, P. L., Billard, V., Hoke, J. F., Moore, K. H. P., Hermann, D. J., Muir, K. T., Mandema, J. W., and Shafer, S. L. (1997). Influence of Age and Gender on the Pharmacokinetics and Pharmacodynamics of Remifentanyl: I. Model Development. *Anesthesiology*, 86(1):10–23. (Cited on pages 106 and 107.)

- [Molchanov and Pyatnitskiy, 1989] Molchanov, A. P. and Pyatnitskiy, Y. S. (1989). Criteria of asymptotic stability of differential and difference inclusions encountered in control theory. *Systems & Control Letters*, 13:59–64. (Cited on pages 24, 51, 53, 54 and 56.)
- [Moreira et al., 2021] Moreira, L. J. D. S., Besançon, G., Ferrante, F., Fiacchini, M., and Roustan, H. (2021). Observer based predictive controller for hall-heroult process. In *2021 European Control Conference (ECC)*, pages 2597–2602. IEEE. (Cited on pages 10, 11 and 31.)
- [Morărescu and Fiacchini, 2014] Morărescu, I.-C. and Fiacchini, M. (2014). LMI conditions for topology preservation : application to multi-agents tasks. *Journal of Control Engineering and Technology*, 4:183–191. (Cited on pages 10 and 33.)
- [Morărescu and Fiacchini, 2016] Morărescu, I.-C. and Fiacchini, M. (2016). Topology preservation for multi-agent networks: design and implementation. In *Delays and Networked Control Systems*, pages 253–269. Springer. (Cited on page 10.)
- [MOSEK ApS, 2015] MOSEK ApS (2015). *The MOSEK optimization toolbox for MATLAB manual. Version 7.1 (Revision 28)*. (Cited on page 41.)
- [Moussa et al., 2019] Moussa, K., Fiacchini, M., and Alamir, M. (2019). Robust optimal control-based design of combined chemo-and immunotherapy delivery profiles. In *FOSBE 2019*. (Cited on pages 9, 12 and 29.)
- [Moussa et al., 2020] Moussa, K., Fiacchini, M., and Alamir, M. (2020). Robust optimal scheduling of combined chemo- and immunotherapy with considerations on chemotherapy detrimental effects. In *American Control Conference, ACC20*. (Cited on pages 9, 12 and 29.)
- [Moussa et al., 2021] Moussa, K., Fiacchini, M., and Alamir, M. (2021). Robust domain of attraction estimation for a tumor growth model. *Applied Mathematics and Computation*, 410:126482. (Cited on pages 12 and 29.)
- [Moussa et al., 2022] Moussa, K., Fiacchini, M., and Alamir, M. (2022). Probabilistically certified region of attraction of a tumor growth model with combined chemo-and immunotherapy. *International Journal of Robust and Nonlinear Control*. (Cited on pages 12 and 29.)
- [Naghshtabrizi et al., 2008] Naghshtabrizi, P., Hespanha, J., and Teel, A. (2008). Exponential stability of impulsive systems with application to uncertain sampled-data systems. *Systems & Control Letters*, 57(5):378–385. (Cited on page 83.)
- [Nikraz, 2010] Nikraz, N. (2010). *Sliding mode functional observers for classes of linear and nonlinear systems*. PhD thesis, School of Electrical, Electronic and Computer Engineering, University of Western Australia. (Cited on page 32.)
- [Olfati-Saber and Murray, 2004] Olfati-Saber, R. and Murray, R. (2004). Consensus problems in networks of agents with switching topology and time-delays. *IEEE Transactions on Automatic Control*, 49:1520–1533. (Cited on page 33.)
- [Pasin et al., 2017] Pasin, L., Nardelli, P., Pintaudi, M., Greco, M., Zambon, M., Cabrini, L., and Zangrillo, A. (2017). Closed-Loop Delivery Systems Versus Manually Controlled Administration of Total IV Anesthesia: A Meta-analysis of Randomized Clinical Trials. *Anesthesia & Analgesia*, 124(2):456–464. (Cited on page 106.)
- [Pons-Salort et al., 2012] Pons-Salort, M., Sanden, B. V., Juhem, A., Popov, A., and Stéphanou, A. (2012). A computational framework to assess the efficacy of the cytotoxic molecules and vascular disrupting agents against solid tumors. *Math. Model. Nat. Phenom.*, 7(1). (Cited on page 29.)
- [Priour et al., 2007] Priour, C., Goebel, R., and Teel, A. R. (2007). Hybrid feedback control and robust stabilization of nonlinear systems. *IEEE Transactions on Automatic Control*, 52(11):2103–2117. (Cited on page 33.)
- [Priour et al., 2010] Priour, C., Tarbouriech, S., and Zaccarian, L. (2010). Guaranteed stability for nonlinear systems by means of a hybrid loop. In *Proceedings of the IFAC Symposium on Nonlinear Control Systems (NOLCOS)*, pages 72–77, Bologna, Italy. (Cited on page 33.)

- [Prieur et al., 2013] Prieur, C., Tarbouriech, S., and Zaccarian, L. (2013). Lyapunov-based hybrid loops for stability and performance of continuous-time control systems. *Automatica*, 49(2):577–584. (Cited on page 33.)
- [Primault et al., 2018] Primault, V., Boutet, A., Mokhtar, S. B., and Brunie, L. (2018). The long road to computational location privacy: A survey. *IEEE Communications Surveys & Tutorials*. (Cited on page 111.)
- [Rawlings et al., 2017] Rawlings, J. B., Mayne, D. Q., and Diehl, M. (2017). *Model predictive control: theory, computation, and design*, volume 2. Nob Hill Publishing Madison, WI. (Cited on pages 27 and 103.)
- [Ren and Beard, 2005] Ren, W. and Beard, R. (2005). Consensus seeking in multiagent systems under dynamically changing interaction topologies. *IEEE Transactions on Automatic Control*, pages 655–661. (Cited on page 33.)
- [Riah, 2016] Riah, R. (2016). *Théorie des ensembles pour le contrôle robuste des systèmes non linéaires: Application à la chimiothérapie et les thérapies anti-angiogéniques*. PhD thesis, la Communauté UNIVERSITÉ GRENOBLE ALPES. (Cited on pages 9 and 12.)
- [Riah and Fiacchini, 2015] Riah, R. and Fiacchini, M. (2015). New condition for invariance of ellipsoidal sets for discrete-time saturated systems. In *The 2015 IEEE Multi-Conference on Systems and Control (MSC15)*. (Cited on pages 8, 12 and 29.)
- [Riah et al., 2015] Riah, R., Fiacchini, M., and Alamir, M. (2015). Invariance-based analysis of cancer chemotherapy. In *2015 IEEE Conference on Control Applications (CCA)*, pages 1111–1116. IEEE. (Cited on pages 9, 12 and 29.)
- [Riah et al., 2016] Riah, R., Fiacchini, M., and Alamir, M. (2016). Domain of attraction estimation of cancer chemotherapy model affected by state proportional uncertainty. In *The 15th European Control Conference 2016 (ECC16)*, pages 2133–2138. IEEE. (Cited on pages 9, 12 and 29.)
- [Riah et al., 2019] Riah, R., Fiacchini, M., and Alamir, M. (2019). Iterative method for estimating the robust domains of attraction of non-linear systems: Application to cancer chemotherapy model with parametric uncertainties. *European Journal of Control*, 47:64–73. (Cited on pages 12 and 29.)
- [Rockafellar, 1970] Rockafellar, R. T. (1970). *Convex Analysis*. Princeton University Press, USA. (Cited on page 53.)
- [Rungger and Tabuada, 2017] Rungger, M. and Tabuada, P. (2017). Computing robust controlled invariant sets of linear systems. *IEEE Transactions on Automatic Control*. (Cited on page 35.)
- [Schneider, 1993] Schneider, R. (1993). *Convex bodies: The Brunn-Minkowski theory*. Cambridge University Press, Cambridge, England. (Cited on page 53.)
- [Schnider et al., 1999] Schnider, T. W., Minto, C. F., Shafer, S. L., Gambus, P. L., Andresen, C., Goodale, D. B., and Youngs, E. J. (1999). The Influence of Age on Propofol Pharmacodynamics. *Anesthesiology*, 90(6):1502–1516. (Cited on pages 106 and 107.)
- [Seuret and Gomes da Silva Jr., 2012] Seuret, A. and Gomes da Silva Jr., J. M. (2012). Taking into account period variations and actuator saturation in sampled-data systems. *Systems & Control Letters*, 61:1286–1293. (Cited on pages 26, 83, 90, 97 and 98.)
- [Smola and Vishwanathan, 2008] Smola, A. and Vishwanathan, S. (2008). *Introduction to machine learning*. Cambridge University, UK. (Cited on page 111.)
- [Stanford and Urbano, 1994] Stanford, D. P. and Urbano, J. M. (1994). Some convergence properties of matrix sets. *SIAM Journal on Matrix Analysis and Applications*, 15(4):1132–1140. (Cited on pages 52 and 73.)
- [Stéphanou et al., 2006] Stéphanou, A., McDougall, S. R., Anderson, A. R. A., and Chaplain, M. A. J. (2006). Mathematical modelling of the influence of blood rheological properties upon adaptive tumor-induced angiogenesis. *Mathematical and Computer Modelling*, 44:96–123. (Cited on page 29.)

- [Struys et al., 2020] Struys, M. M., Absalom, A. R., and Shafer, S. L. (2020). Intravenous Drug Delivery Systems. In *Miller's Anesthesia*, pages 884–936. Elsevier, ninth edition. (Cited on page 106.)
- [Sun, 2004] Sun, Z. (2004). Stabilizability and insensitivity of switched linear systems. *IEEE Transactions on Automatic Control*, 49(7):1133–1137. (Cited on page 52.)
- [Sun and Ge, 2011] Sun, Z. and Ge, S. S. (2011). *Stability Theory of Switched Dynamical Systems*. Springer. (Cited on pages 8, 24, 51, 52, 55, 65 and 70.)
- [Sussmann et al., 1994] Sussmann, H. J., Sontag, S. D., and Yang, Y. (1994). A general result on the stabilization of linear systems using bounded controls. *IEEE Transactions on Automatic Control*, 39(12):2411–2425. (Cited on page 85.)
- [Tahir and Jaimoukha, 2015] Tahir, F. and Jaimoukha, I. M. (2015). Low-complexity polytopic invariant sets for linear systems subject to norm-bounded uncertainty. *IEEE Transactions on Automatic Control*, 60(5):1416–1421. (Cited on pages 23 and 35.)
- [Tarbouriech et al., 2011] Tarbouriech, S., Garcia, G., I., J. G., and Queinnec (2011). *Stability and stabilization of linear systems with saturating actuators*. Springer Science & Business Media. (Cited on pages 8, 26, 83, 87, 88, 89 and 91.)
- [Tempo et al., 2013] Tempo, R., Calafiore, G., and Dabbene, F. (2013). *Randomized algorithms for analysis and control of uncertain systems: with applications*. Springer. (Cited on page 103.)
- [Thonstad et al., 2001] Thonstad, J., Fellner, P., Haarberg, G. M., Hives, J., Kvande, H., and Sterten, Å. (2001). Aluminium electrolysis 3rd edition ed. *Breuerdruck, Germany: Aluminium-Verlag Marketing & Kommunikation GmbH*. (Cited on page 109.)
- [Tiwary, 2008] Tiwary, H. R. (2008). On the hardness of computing intersection, union and Minkowski sum of polytopes. *Discrete & Computational Geometry*, 40(3):469–479. (Cited on pages 38 and 39.)
- [Trinh and Fernando, 2012] Trinh, H. and Fernando, T. (2012). *Functional Observers for Dynamical Systems*, volume 420 of *Lecture Notes in Control and Information Sciences*. Springer. (Cited on page 32.)
- [van Heusden et al., 2014] van Heusden, K., Dumont, G. A., Soltesz, K., Petersen, C. L., Umedaly, A., West, N., and Ansermino, J. M. (2014). Design and clinical evaluation of robust pid control of propofol anesthesia in children. *IEEE Transactions on Control Systems Technology*, 22(2):491–501. (Cited on pages 9 and 30.)
- [Van Loan, 1977] Van Loan, C. (1977). The sensitivity of the matrix exponential. *SIAM Journal on Numerical Analysis*, 14(6):971–981. (Cited on page 93.)
- [VanAntwerp and Braatz, 2000] VanAntwerp, J. G. and Braatz, R. D. (2000). A tutorial on linear and bilinear matrix inequalities. *Journal of Process Control*, 10(4):363–385. (Cited on page 63.)
- [Zabi et al., 2015] Zabi, S., Queinnec, I., Tarbouriech, S., and Mazerolles, M. (2015). New approach for the control of anesthesia based on dynamics decoupling. In *9th IFAC Symposium on Biological and Medical Systems*, Berlin, Germany. (Cited on pages 9 and 30.)
- [Zamani et al., 2015] Zamani, M., Abate, A., and Girard, A. (2015). Symbolic models for stochastic switched systems: A discretization and a discretization-free approach. *Automatica*, 55:183–196. (Cited on page 103.)
- [Zavlanos and Pappas, 2008] Zavlanos, M. and Pappas, G. (2008). Distributed connectivity control of mobile networks. *IEEE Transactions on Robotics*, 24(6):1416–1428. (Cited on pages 10 and 33.)
- [Zhang et al., 2009] Zhang, W., Abate, A., Hu, J., and Vitus, M. P. (2009). Exponential stabilization of discrete-time switched linear systems. *Automatica*, 45(11):2526–2536. (Cited on pages 24, 25, 75, 78 and 79.)
- [Zhang et al., 2001] Zhang, W., Branicky, M., and Phillips, S. (2001). Stability of networked control systems. *IEEE control systems magazine*, 21(1):84–99. (Cited on page 8.)

-
- [Zhang et al., 2012] Zhang, W., Hu, J., and Abate, A. (2012). Infinite-horizon switched lqr problems in discrete time: a suboptimal algorithm with performance analysis. *IEEE Transactions on Automatic Control*, 57(7):1815–1821. (Cited on pages 25, 78 and 79.)