



**HAL**  
open science

# Asymptotic properties of tropical refined invariants

Gurvan Mével

► **To cite this version:**

Gurvan Mével. Asymptotic properties of tropical refined invariants. Algebraic Geometry [math.AG]. Nantes Université, 2024. English. NNT: . tel-04759642

**HAL Id: tel-04759642**

**<https://hal.science/tel-04759642v1>**

Submitted on 30 Oct 2024

**HAL** is a multi-disciplinary open access archive for the deposit and dissemination of scientific research documents, whether they are published or not. The documents may come from teaching and research institutions in France or abroad, or from public or private research centers.

L'archive ouverte pluridisciplinaire **HAL**, est destinée au dépôt et à la diffusion de documents scientifiques de niveau recherche, publiés ou non, émanant des établissements d'enseignement et de recherche français ou étrangers, des laboratoires publics ou privés.

# THÈSE DE DOCTORAT DE

NANTES UNIVERSITÉ

ÉCOLE DOCTORALE N° 641  
*Mathématiques et Sciences et Technologies  
de l'Information et de la Communication*  
Spécialité : *Mathématiques et leurs interactions*

Par

**Gurvan MÉVEL**

## Propriétés asymptotiques des invariants tropicaux raffinés

Thèse présentée et soutenue à Nantes le 23 septembre 2024  
Unité de recherche : Laboratoire de Mathématiques Jean Leray (LMJL)

### Rapporteur·euse avant soutenance :

Hannah MARKWIG Professeure, Universität Tübingen  
Eugenii SHUSTIN Professeur, Tel-Aviv University

### Composition du Jury :

Président :	Iliia ITENBERG	Professeur, Sorbonne Université
Examinateur·ices :	Omid AMINI Penka GEORGIEVA Marco GOLLA Lucía LÓPEZ DE MEDRANO Hannah MARKWIG Eugenii SHUSTIN	Professeur, École Polytechnique Professeure, Sorbonne Université Chargé de recherche, CNRS et Nantes Université Professeure, Universidad Nacional Autónoma de México Professeure, Universität Tübingen Professeur, Tel-Aviv University
Dir. de thèse :	Erwan BRUGALLÉ	Professeur, Nantes Université



Rem

*La cité rutilante au cœur du temps, tel un rubis parmi les perles de bois flotté d'un collier à la dérive dans un paysage de noir sur noir. Tout ce qui a précédé allait crescendo, et tout ce qui suivra s'amenuisera. Elle finira par s'abîmer dans ces ténèbres, et tout ce qu'elle aura accompli retournera à la poussière. Ça n'a strictement aucune importance. Elle existe à cet instant et, toujours, elle aura existé. Cela suffit.*

Zuleika

*Personne n'a dit que ce serait facile, et ça ne l'a pas été. Mais nous l'avons fait quand même.*

---

*La Cité de Soie et d'Acier [CCC23],  
Linda, Louise et Mike Carey*



# Remerciements

---

*« Je ne connais pas la moitié d'entre vous à moitié autant que je le voudrais ; et j'aime moins que la moitié d'entre vous à moitié aussi bien que vous le méritez. »*

---

*Le Seigneur des Anneaux - Intégrale,  
J.R.R. Tolkien [Tol12]*

En commençant ces lignes je pensais que le plus dur avait été fait. Je me trompais, encore une fois. Cette partie, forcément trop longue, sera aussi inévitablement trop courte. Elle sera surtout insatisfaisante, par mon incapacité à trouver les mots justes.

J'aimerais d'abord remercier un homme enjoué de m'avoir un jour proposé un stage de L3, puis d'avoir accepté de me prendre en thèse. Je ne suis pas encore sûr aujourd'hui de mesurer la chance et l'honneur qu'il m'a fait de me guider dans le monde de la recherche. Il m'est difficile d'exprimer correctement ma gratitude : pour sa patience, ses réponses à mes questions (maintes fois répétées), son accompagnement, et pour toutes les bénédictions (elles sont nombreuses !) qu'il a pu m'accorder ces trois dernières années. Alors simplement, merci Erwan !

Merci à Hannah Markwig et Eugenio Shustin d'avoir accepté de rapporter ma thèse. C'est un honneur que vous me faites. Merci également d'avoir accepté d'être membres du jury. Merci à Omid Amini, Penka Georgieva, Marco Golla, Ilia Itenberg et Lucía López de Medrano pour faire partie du jury. L'intérêt que vous portez à mes travaux me touche.

Il s'en passe des choses en trois ans, et il s'en trouve des personnes à remercier. J'aimerais commencer par saluer l'ensemble du LMJL. La bonne ambiance et le dynamisme du labo sont indéniables. On se sent bien ici, et on part avec regrets. Merci Béatrice pour toute ton aide administrative. Je reste surpris que tu saches toujours exactement la raison de ma venue dans ton bureau. Merci à Anaïs G. pour ton aide précieuse sur les RDL, pour Math en Jeans, ainsi que pour nous avoir fait découvrir le Zed. Merci à Caroline de vitaliser le labo, et merci à Stéphanie. Merci à Anh et Naïma (et Claude) de veiller sur le CRDM, et merci infiniment pour la plaquette des RDL. Merci à Éric et Saïd pour la résolution de mes pépins informatiques.

Merci à Baptiste pour tes conseils sur l'enseignement et le soutien que tu as pu m'apporter. Merci à Marco qui, après avoir épuisé l'intégralité des problèmes à base de constructions farfelues sur des triangles, s'est mis à me poser des problèmes à base de constructions farfelues sur des pentagones. Merci pour ta bienveillance et ton soutien. Merci à Stéphane et Fabio pour votre gentillesse et votre disponibilité. Merci à Gabriel de m'avoir reconnu sans me connaître. Merci

à Joe pour le club de maths et m'avoir orienté vers le Fablab. Merci à Aymeric pour Math en Jeans. Merci à Claire de rôder dans les couloirs. Merci à Damien G. de m'avoir rassuré plus d'une fois vis-à-vis de l'enseignement. Merci à Anaïs C. pour ta gentillesse. Merci à François pour les précieux conseils à quelques jours de la soutenance. Merci à Salim pour ton enthousiasme débordant de café, et à Hossein de régaler nos boîtes mails. Merci à Assia pour ta bienveillance, et à Matthieu pour ton aide.

Les personnes que j'ai le plus côtoyées sont bien sûr les autres (post-)doctorant-es. Nul doute que les meilleures pauses post-déjeuners du monde ont lieu dans la salle commune ludique du LMJL, et que le labo a les infrastructures nécessaires pour accueillir la coupe du monde de plumfoot. Merci aux irréductibles de la dernière heure qui ont vérifié avec moi que oui, la finale pouvait se jouer en salle Auval.

Une pensée pour les locataires du bureau 009, qui ont partagé avec moi les meilleurs moments du bureau d'à côté. Merci à Alexandre pour ton conseil lecture. Merci à Adrien qui m'a accueilli au labo et guidé dans les embûches administratives. Merci surtout de nous avoir servi un gâteau de crêpes mémorable, dont la saveur n'a d'égale que la densité. Si les scientifiques avaient voulu créer un trou noir parfum chocolat et mascarpone en laboratoire, iels n'auraient pas mieux fait. Merci à Azzedine et Aleksandar pour votre calme et gentillesse. C'est dommage qu'on ne se soit pas plus vus! Merci à Giovanni d'apprécier avec moi le *battlefield* du bureau voisin. Merci à Estelle et François, sans l'absence de qui je n'aurais pas pu étaler mes affaires dans le bureau. Merci à mon petit frère Enzo, le néo-influenceur LinkedIn que toutes les ED s'arrachent, pour le temps passé ensemble à Turin. Ça a été un plaisir de partager le même bureau pour le dernier mois. Et bien sûr merci à Paul! Merci de faire des CC plus hardcore que les miens et d'avoir aiguisé mes compétences de recherche du meilleur gif. Merci pour Blokus et les matroïdes. Merci d'avoir partagé ma détresse devant l'incompréhensibilité du monde mathématique. Merci bien sûr pour ton poster inoubliable. Je n'imagine pas un bureau sans toi! Je te réserverai toujours un petit coin de table si tu veux passer. J'en profite pour remercier Alice L. également. J'espère que les prochains gouvernements seront aussi bons que ceux des dernières années, pour qu'on puisse à nouveau se promener dans le centre de Nantes à la lueur des torches.

Un peu plus loin dans le couloir se trouve le bureau de Damien P. et Thomas. Merci à vous pour le duo incontournable que vous formez. Merci à Damien pour les séances de badminton. Ton poster était très bien! Mais je ne te pardonne pas la fourbasserie du DJ set aux Foulées de l'Éléphant... Merci à Thomas; ta propension à tricher en souriant a quelque chose d'agaçant, mais je ne peux pas en vouloir à notre n°10 du plumfoot. Merci à Klervi, notre ex-espionne infiltrée dans le monde d'en haut, qui semble connaître tous les bruits de couloirs du labo. C'est toujours un plaisir de fêter tes 18 ans aux RDL, et j'espère ne pas les manquer l'année prochaine. Merci à Destin pour avoir partagé avec moi les retards de paiement et m'avoir exposé ta théorie sur la pression sociale. N'oublie pas que l'être humain est un animal diurne avant tout; si tu lis

ceci entre minuit et 6h du matin, va plutôt dormir un peu. Merci à Flavien pour tes expressions inattendues et surprenantes, j'espère que tu te souviendras longtemps de ce qu'est  $\mathbb{C}P^2$ . Merci également à Valentin pour ton humour moyen que les esthètes savent apprécier, et pour ton incapacité à faire semblant de ne pas rire.

Merci à Gaspard pour les jeux que tu m'as fait découvrir et le squash. Merci pour ton engagement et la super banane qui va avec. Merci à Laurine, pour les mêmes raisons. Je me souviendrai longtemps des 6h passées ensemble sur Guilty! Merci à Charbella pour tes bonjours toujours souriants le matin et pour ton optimisme pétillant à la conférence master. Merci à Adrian, on peut toujours compter sur toi pour un plumfoot ou pour expliquer des maths, même si je n'ai toujours pas compris le titre de ta thèse. Merci à Antoine d'avoir légué un canapé que la nouvelle génération utilise à profit. Merci à Anh, ma sœur Anh, pour nous avoir entraîné-es dans la fièvre du plumfoot. Tu as créé une religion et tu es notre prophète! Merci également pour les bons moments passés en conférences, du Croisic jusqu'au CIRM.

Merci à Ziyad de nous illuminer de tes éclats de sagesse infinie<sup>1</sup> et pour ton calme en toutes circonstances. Merci à Elric pour ton enthousiasme pour les jeux comportant 50 personnages, 120 méchants, 576 jetons et 4237 cartes. Un jour, je serai dispo pour les catacombes! Merci également à vous deux pour le premier quiz du labo. Merci à Alexandre pour ta franchise qui permet de jouer souder tous-tes ensemble, dans la bienveillance et le respect d'autrui. Merci à Clément pour tes passages aussi rares qu'intenses au labo. Merci à Silvère pour avoir étoffé l'offre de jeux à disposition quand on commençait à tourner en rond le midi, et pour faire des maths encore moins concrètes que les miennes; et merci à Alice B. pour tes conseils dans la dernière ligne droite. Merci à Agustín d'avoir rejoint avec entrain et succès la spirale infernale du Hanabi.

Merci à Florent pour m'avoir virtuellement permis de collectionner des orteils; j'aurais dû en profiter davantage! Merci à Aline et Bastien pour une soirée jeux fort sympathique. Par peur de me faire engueuler si je mets un mot de travers, je resterai sobre pour remercier Nadia. *Grazie* Arianna pour être devenue la plus fervente amatrice de *pallamano* que je connaisse et pour tes conseils rando autour du *lago di Como*. Merci à Gaëlle, j'aurais aimé être présent pour ton dernier jour au labo. Merci à Hanine pour ta gentillesse, à Ludovic pour ta personnalité, à Jean pour ta décontraction, à Anthony, Hai, Oğuz, Khaled, Fabrice, Lucas, Samuel. Une pensée pour les nouveaux venus Maxime, Herman, Julien, Romain : merci d'assurer la relève.

Les maths ne sont pas une activité sédentaire et de nombreuses occasions de voyager et rencontrer des gens se présentent. Merci aux géomètres réel·les de l'ouest, en particulier à François pour la pire imitation du monde et à Thibault pour la meilleure imitation de la pire imitation du monde. Merci à Andrés qui, pour une raison qui m'échappe, a accepté d'échanger une saucisse contre un peu de chou un soir au CIRM. Merci à Thomas d'organiser des conférences dans

---

1. « Vous trouvez pas que le 9 février c'est un jour random? »



des chalets au bord d'un lac. Merci à ma sœur Matilde pour tes anecdotes et ta jovialité plus que communicative. Merci à Antoine de m'avoir hébergé à Annemasse. Merci à Victoria pour avoir amélioré ma black box à GAeL. Merci à Fathi Ben Aribi de toujours réussir à positiver ; ton optimisme rassure et fait beaucoup de bien. Merci à Olivier Benoist de prendre le temps d'expliquer et de taroter à l'occasion. Merci à Johannes Rau pour ta bienveillance.

Merci à Franck et Armelle (ainsi que Richard et Yves) pour m'avoir accompagné dans Math en Jeans. C'était un réel plaisir d'encadrer ces ateliers avec vous, et j'aurais aimé continuer l'an prochain.

Tuve la oportunidad de hacer una estancia en Mexico, y querría agradecer a todas las personas que encontré y que me ayudaron allí. Especialmente, gracias a mi gran hermano Cristhian y a mi casi tía Lucía que me dieron la bienvenida. Gracias a Joana por la agua de horchata. Merci à Antonin "el Cachanese" de m'avoir permis de parler un peu français, à Benoît pour m'avoir emmené dans un restaurant de mafieux, et à Jawad. Gracias a Isaac y Carlos por el médico, y por acompañarme y guiarme en muchas ocasiones. Gracias a Santiago por los insultos colombianos. Gracias a Esteban y Omarcito por la playa. Gracias a Luis por los memes. Gracias también a Anabella, José, Vinicio, Gabriel y todes les otros. ¡ Y no olviden! "Para todo mal, mezcal; para todo bien, también. Y si no hay remedio, litro y medio."

Merci enfin à toutes les personnes qui étaient là avant la thèse. Un immense merci en particulier à Yann et Marie! Cette thèse est un peu la vôtre et vous doit son existence ; vous le savez. Je pourrais vous réserver un chapitre complet, et ce ne serait toujours pas assez. Merci, merci, et merci à vous deux! Merci à Magali pour ta curiosité et ta malice. Merci à Clémentine, Gaspard (bis?) et Marie (bis!) pour les ciné-raclettes pendant l'agrèg. Merci aux excellent·es profs dont j'ai pu suivre les cours, en particulier Benoît, Delphine, Goulwen. Merci aux Malpropres Jules, Louis, Briec, Yohan, Léo et Hugo pour l'équipe de choc que vous formez. Merci aux Clémancien·nes pour les excellents souvenirs avec vous depuis plus de 10 ans! Une pensée en particulier pour Ray, Lisa et Clara que j'ai plus vu·es ces trois dernières années. Si vous voulez comprendre mon sujet de thèse, c'est maintenant! Merci à Ray, premier pote au lycée, pour m'avoir entraîné à l'escalade, à Lisa pour essayer de poser les bonnes questions, à Clara pour les fois où l'on s'est croisé sur les bords de la Sèvre. Merci également à Ahmed, Sélim et Antoine. *Choukran* aux braves du cours d'arabe, notamment Agathe pour les incroyables moments que cette langue nous a fait passer ensemble. Merci à Nao de m'avoir fait découvrir d'excellents bouquins. Merci à ma famille, à mes parents et à Glen. Merci enfin à Ewen d'être mon meilleur ami depuis la naissance.

« À tout à l'heure. *Koupik.* »

---

Loulou





# Table of Contents

---

<b>Résumé de la thèse en français</b>	<b>15</b>
1 Introduction . . . . .	15
2 Invariants de Göttsche-Schroeter en genre quelconque . . . . .	17
3 Formules universelles en genre 0 et 1 . . . . .	18
4 Série génératrice à codegré fixé . . . . .	22
<b>1 Introduction</b>	<b>23</b>
1.1 Algebraic enumerative geometry . . . . .	23
1.1.1 Complex enumeration . . . . .	23
1.1.2 Polynomiality and Göttsche’s conjecture . . . . .	24
1.1.3 Real enumeration . . . . .	25
1.2 Tropical enumerative geometry . . . . .	26
1.2.1 Correspondence theorems . . . . .	26
1.2.2 A new tool : floor diagrams . . . . .	27
1.3 Refined enumerations . . . . .	27
1.3.1 Block-Göttsche multiplicity . . . . .	27
1.3.2 Interpretations . . . . .	28
1.3.3 Polynomiality strikes back . . . . .	29
1.4 Results of this thesis . . . . .	29
1.4.1 Göttsche-Schroeter invariants in higher genus . . . . .	29
1.4.2 Polynomiality and universal generating series . . . . .	30
1.4.3 Generating series at fixed codegree . . . . .	33
<b>2 Preliminaries</b>	<b>35</b>
2.1 Toric surfaces . . . . .	35
2.1.1 Cones and fans . . . . .	35
2.1.2 Polygons and duality . . . . .	36
2.1.3 Toric surfaces and linear systems . . . . .	38
2.2 Floor diagrams and tropical refined invariants . . . . .	40
2.2.1 $h$ -transverse polygons and floor diagrams . . . . .	40
2.2.2 Refined invariants . . . . .	44
2.2.3 Few lemmas on floor diagrams . . . . .	48

TABLE OF CONTENTS

---

2.3	From tropical refined invariants to asymptotic refined invariants . . . . .	56
2.3.1	Motivations . . . . .	56
2.3.2	A new multiplicity . . . . .	56
2.3.3	Asymptotic refined invariants . . . . .	59
<b>3</b>	<b>Göttsche-Schroeter invariants in higher genus</b>	<b>61</b>
3.1	Refined invariants in the non-rational case . . . . .	61
3.1.1	Definition of $G_g(\Delta, s)$ . . . . .	61
3.1.2	Properties of the invariants . . . . .	69
3.2	Examples and conjectures . . . . .	73
3.2.1	Some calculations . . . . .	73
3.2.2	Observations and conjectures . . . . .	83
<b>4</b>	<b>Generating series in genus 0</b>	<b>87</b>
4.1	Universal series in genus 0 . . . . .	87
4.1.1	Non-singular and horizontal polygons . . . . .	89
4.1.2	The blow-up trick and the case of $\mathbb{CP}^2$ . . . . .	95
4.1.3	The non-singular case . . . . .	102
4.1.4	The case of singular surfaces . . . . .	105
4.1.5	Some technical lemmas . . . . .	108
4.2	Genus 0 asymptotic refined invariant . . . . .	110
4.2.1	Reformulation of theorems of section 4.1 . . . . .	110
4.2.2	The case of Hirzebruch surfaces . . . . .	114
4.2.3	The case of non-singular and horizontal toric surfaces . . . . .	121
4.3	Examples . . . . .	127
<b>5</b>	<b>Generating series in genus 1</b>	<b>129</b>
5.1	Nerved diagrams : from genus 0 to genus 1 diagrams . . . . .	129
5.1.1	Marked nerved diagrams . . . . .	129
5.1.2	Constructing genus 1 nerved diagrams from genus 0 ones . . . . .	131
5.2	Integration over the space of genus 0 diagrams . . . . .	134
5.2.1	Measures and new formalism . . . . .	134
5.2.2	Some integral computations . . . . .	135
5.3	Computation of the asymptotic refined invariants . . . . .	140
5.3.1	The Hirzebruch case . . . . .	140
5.3.2	The case of non-singular and horizontal toric surfaces . . . . .	144

<b>6</b>	<b>Generating series at fixed codegree</b>	<b>149</b>
6.1	Reminder on diagrams of codegree 0 . . . . .	149
6.2	Degree 0 terms . . . . .	150
6.3	Degree 1 terms . . . . .	151
	<b>Bibliography</b>	<b>157</b>



# Résumé de la thèse en français

---

## 1 Introduction

Cette thèse s'intéresse à la géométrie énumérative des courbes algébriques sur des surfaces toriques. Elle est dédiée à l'étude asymptotique des invariants tropicaux raffinés, en particulier en genre 0 et 1, via l'utilisation des diagrammes en étages. Avant de parler d'invariants raffinés, récapitulons d'où vient ce problème.

### Quelques problèmes énumératifs

Il est connu depuis fort longtemps que par deux points passe une unique droite. Bien que facile, des questions similaires peuvent se formuler dans des contextes bien plus généraux. Fixons  $X$  une surface algébrique complexe non-singulière et  $\mathcal{L}$  un fibré en droites sur  $X$  suffisamment ample. On définit une courbe sur  $X$  comme étant le lieu d'annulation d'une section de  $\mathcal{L}$ . Si on choisit  $\frac{\mathcal{L}^2 + c_1(X) \cdot \mathcal{L}}{2} - \delta$  points sur  $X$ , on peut se demander combien de courbes avec  $\delta$  points doubles passent par ces points. On note  $N^\delta(\mathcal{L})$  ce nombre, qui ne dépend pas du choix des points. Par la formule d'adjonction qui relie le genre et le nombre de points doubles d'une courbe, on peut également choisir  $c_1(X) \cdot \mathcal{L} - 1 + g$  points et compter les courbes de genre  $g$  qui passent par ces points. On obtient un entier  $N_g(\mathcal{L})$ . Ces nombres correspondent à des invariants de Gromov-Witten.

Bien que liés l'un à l'autre, les entiers  $N^\delta(\mathcal{L})$  et  $N_g(\mathcal{L})$  se comportent très différemment. Les conjectures de Di Francesco-Itzykson [DFI95] et Göttsche [Göt98] stipulent que  $N^\delta(\mathcal{L})$  varie polynomialement lorsque  $\mathcal{L}$  varie. Göttsche donne même une formule pour la série génératrice de ces nombres. Ces conjectures ont été prouvées par Fomin et Mikhalkin [FM10] dans le cas où  $X = \mathbb{CP}^2$ , et par Tzeng [Tze12] en général. En revanche, pour le nombre dual  $N_g(\mathcal{L})$  Di Francesco et Itzykson [DFI95] ont montré qu'en genre 0 et pour les courbes de degré  $d$  sur  $\mathbb{CP}^2$  on a  $\ln(N_0(d)) \sim 3d \ln(d)$ , anéantissant l'espoir d'un comportement polynomial.

Plutôt que de compter des courbes dans le plan complexe, on peut vouloir compter des courbes dans le plan réel. Une difficulté majeure est que le nombre de courbes dépend alors des points qu'on a choisis, de la même façon que le nombre de racines réelles d'un polynôme réel dépend de ses coefficients. Cependant, Welschinger [Wel05] a montré qu'en genre 0, compter les courbes avec un signe  $\pm 1$  donnait lieu à un invariant  $W(d)$ . Toujours dans ce cadre, plutôt que de fixer une configuration de *points réels* on peut fixer une *configuration réelle* de points. Une telle configuration est formée de points réels et de paires de points complexes conjugués, et



l'énumération ne dépend toujours pas du choix des points. Cependant, il faut noter que cette invariance du compte de courbes avec signes est spécifique au genre 0.

### Comment déterminer $N_g(\mathcal{L})$ ou $W(d)$ ?

Il est en général compliqué de calculer  $N_g(\mathcal{L})$  ou  $W(d)$ . Néanmoins, la géométrie tropicale fournit des méthodes pour aborder ces questions. En particulier, le théorème de correspondance de Mikhalkin [Mik05] ramène l'énumération de courbes algébriques sur des surfaces toriques à celle de courbes tropicales. Sous une hypothèse technique de  $h$ -transversalité, Brugallé et Mikhalkin ont ensuite réduit cette énumération à celle d'un certain type de graphes appelés *diagrammes en étages* [BM07, BM08], qui sont l'outil central de cette thèse. Cette approche via la géométrie tropicale s'avère féconde. Si de nombreux résultats classiques peuvent être redémontrés dans ce contexte, les diagrammes en étages fournissent aussi un outil concret pour étudier ces problèmes énumératifs. Un intérêt de cette approche combinatoire est qu'elle permet de s'affranchir de certaines hypothèses. Elle autorise en particulier à regarder des surfaces singulières, qui n'entrent pas dans le cadre de la conjecture de Göttsche. De tels objets singuliers ont par exemple été considérés par Ardila et Block [AB13], ainsi que par Liu et Osserman [LO18].

### Raffinons l'énumération

L'énumération tropicale requiert d'associer à chaque courbe tropicale ou diagramme en étages une multiplicité entière. Les travaux de Mikhalkin mettent en évidence deux multiplicités : l'une permet de retrouver les invariants de Gromov-Witten  $N_g(\mathcal{L})$ , l'autre les invariants de Welschinger  $W(d)$ . Block et Göttsche ont proposé d'utiliser une troisième multiplicité, cette fois-ci polynomiale [BG16b]. Elle dépend d'une variable  $q$  et interpole entre les précédentes multiplicités. Le résultat du comptage de diagrammes en étages (ou de courbes tropicales), est alors un polynôme à coefficients entiers, appelé *invariant tropical raffiné*. On le note  $G_g(\Delta)(q)$ , où  $g$  est le genre considéré et  $\Delta$  est un polygone qui permet de définir précisément les données du problème énumératif, via les géométries torique et tropicale. Cet invariant raffiné prend comme valeur particulière en  $q = 1$  et  $q = -1$  les invariants de Gromov-Witten et ceux de Welschinger. En genre  $g = 0$ , Göttsche et Schroeter ont défini une quantité similaire [GS19], qui prend également en compte le nombre  $s$  de paires de points complexes conjugués que l'on fixe dans la configuration de points. On note cette quantité  $G_0(\Delta, s)(q)$ .

Dans l'énumération à nombre de points doubles  $\delta$  fixés, on observe sans surprise que les coefficients de l'invariant raffiné ont eux-même un comportement polynomial. De façon plus étonnante, Brugallé et Jaramillo-Puentes ont montré que c'est encore le cas, du moins en partie, lorsque le genre  $g$  est fixé [BJP22]. Le but de cette thèse est d'étudier cette polynomialité et de montrer, dans l'esprit de la conjecture de Göttsche, des formules universelles pour les coefficients des invariants tropicaux raffinés.

## 2 Invariants de Göttsche-Schroeter en genre quelconque

Un premier travail de cette thèse est d'étendre la définition des invariants de Göttsche-Schroeter au genre  $g > 0$ . Pour cela, il convient de regarder précisément comment, en genre 0, ces invariants sont-ils calculés par les diagrammes en étages. La recette est la suivante.

1. Choisir un entier positif  $s$  qui représente le nombre de paires de points complexes conjugués que l'on fixe pour compter les courbes, ainsi qu'un *appariement*  $S$  d'ordre  $s$ .
2. Lister tous les diagrammes en étages marqués.
3. Pour chaque diagramme en étage marqué, déterminer sa  $S$ -multiplicité raffinée.
4. Sommer toutes les  $S$ -multiplicités raffinées.

En genre 0, on obtient le polynôme  $G_0(\Delta, s)$  qui ne dépend pas du choix de l'appariement  $S$  tant que celui-ci est d'ordre  $s$ . Ce fait provient de l'indépendance *géométrique* du nombre de courbes vis-à-vis du choix des points. Pour étendre les invariants de Göttsche-Schroeter au genre positif, l'idée est d'appliquer la même recette à des diagrammes de genre positif pour obtenir un polynôme  $G_g(\Delta, S)$  qui a priori dépend de  $S$ , et de montrer une indépendance *combinatoire* vis-à-vis de  $S$ . C'est le contenu du théorème suivant.

**Théorème 3.1.3.** *Soit  $\Delta$  un polygone  $h$ -transverse et  $g \in \mathbb{N}$ . Soit  $s \in \mathbb{N}$  et  $S, S'$  deux appariements d'ordre  $s$ . Alors  $G_g(\Delta, S) = G_g(\Delta, S')$ . On peut donc noter cette quantité  $G_g(\Delta, s)$ .*

Pour prouver ce théorème, il est suffisant de fixer deux appariements  $S$  et  $S'$  qui diffèrent d'une unique paire. La démonstration est alors une étude de cas, en fonction de comment la paire en question apparaît dans les diagrammes en étages marqués. On montre qu'on peut regrouper les diagrammes en étages marqués par paquets, et que l'invariance apparaît au sein de chacun de ces paquets. Ce sont des calculs qui reposent sur le lemme technique 3.1.2, mais qui sont valides pour tout genre  $g \geq 0$ .

On obtient donc un nouvel<sup>1</sup> invariant  $G_g(\Delta, s)$ . On montre ensuite qu'il vérifie certaines propriétés déjà connues dans le cas du genre 0. En particulier, on étudie la dépendance en  $s$  de cet invariant. Dans l'énoncé suivant, la notation  $\langle G_g(\Delta, s) \rangle_i$  représente le coefficient de codegré  $i$  de  $G_g(\Delta, s)$ . Les autres notations sont définies au chapitre 2.

**Théorème 3.1.8.** *Soit  $\Delta$  un polygone  $h$ -transverse et  $g \leq g_{\max}(\Delta)$ . Si  $2i \leq e^{-\infty}(\Delta)$  et  $i \leq g_{\max}(\Delta)$ , alors les valeurs  $\langle G_g(\Delta, s) \rangle_i$  pour  $0 \leq s \leq s_{\max}(\Delta, g)$  sont interpolées par un polynôme de degré  $i$ , dont le coefficient dominant est  $\frac{(-2)^i}{i!} (g_{\max} - i)$ .*

Ce résultat avait été prouvé par Brugallé et Jaramillo-Puentes dans le cas du genre 0 [BJP22].

1. De façon indépendante et simultanée à cette thèse, Shustin et Sinichkin ont également proposé une généralisation au genre quelconque des invariants de Göttsche-Schroeter, en utilisant des méthodes géométriques [SS24]. Dans les cas où l'on a des diagrammes en étages, on peut montrer que les deux généralisations coïncident.

La démonstration en genre quelconque est simplement une adaptation de leur méthode, qui requiert de décrire comment le genre peut apparaître dans les diagrammes en étages qui contribuent.

Enfin, on illustre cette partie avec de nombreux exemples. Les observations qu'on en tire permettent notamment de formuler la conjecture suivante. Dans l'énoncé, le polygone  $\Delta_{a,b}^n$  indique que l'on considère l'énumération des courbes de bidegré  $(a, b)$  sur la surface de Hirzebruch  $\mathbb{F}_n$ , voir l'exemple 2.1.13.

**Conjecture 3.2.16, formule d'Abramovich-Bertram.** *Soit  $a, b \in \mathbb{N}$  et  $g \geq 0$ . Pour tout  $s \geq 0$  on a*

$$G_g(\Delta_{a,a+b}^0, s) = \sum_{j=0}^a \binom{b+2j}{j} G_g(\Delta_{a-j,b+2j}^2, s).$$

La formule d'Abramovich-Bertram est une égalité géométrique, vérifiée notamment par les degrés de Severi  $N_g(\Delta_{a,b}^n)$  [AB01, Vak00, BP15]. Bousseau a également montré que les invariants de Block-Göttsche, i.e.  $G_g(\Delta_{a,b}^n, 0)$  la satisfont [Bou21]. Si la conjecture ci-dessus est vraie, elle plaide en faveur d'une interprétation géométrique des invariants de Göttsche-Schroeter en genre positif<sup>2</sup>. C'est une question qu'il serait intéressant d'étudier.

### 3 Formules universelles en genre 0 et 1

Le cœur de cette thèse est l'étude des invariants raffinés  $G_g(\Delta, s)$  dans les cas où  $g = 0$  et  $g = 1$ . Plus précisément, étant donné la conjecture de Göttsche [Göt98, Tze12] et les résultats de polynomialité de Brugallé et Jaramillo-Puentes [BJP22], le but est de montrer qu'il existe des séries universelles qui donnent asymptotiquement les coefficients de  $G_g(\Delta, s)$ .

#### Le cas du genre 0

Introduisons quelques notations avant d'énoncer les résultats. On a déjà mentionné que les problèmes énumératifs considérés sont codés par des polygones. Plus précisément, si  $\Delta$  est un polygone convexe à sommets entiers dans  $\mathbb{R}^2$ , il définit une surface torique  $X_\Delta$  et un fibré en droites  $\mathcal{L}_\Delta$ . Les courbes algébriques que l'on cherche à compter sont alors des lieux d'annulation de sections de  $\mathcal{L}_\Delta$ . On notera  $y(\Delta) = c_1(X_\Delta) \cdot \mathcal{L}_\Delta$  et  $\chi(\Delta) = c_2(X_\Delta)$ . On considère les séries formelles

$$A(x) = \frac{1}{1-x}, \quad B(x) = \frac{1}{1-x^2}, \quad P(x) = \prod_{k \geq 1} \frac{1}{1-x^k},$$

---

2. Shustin et Sinichkin montrent que l'évaluation en  $q = 1$  des invariants qu'ils proposent [SS24] donne le nombre de courbes satisfaisant certaines conditions d'incidence et de tangence. La formule d'Abramovich-Bertram, ou une formule comme la proposition 3.1.7, expliqueraient ce résultat.

et étant donné trois entiers  $y$ ,  $\chi$  et  $s$  on note

$$\sum_{i \geq 0} P_i(y, \chi, s) x^i := A^{y-2-2s} B^s P^\chi.$$

La fonction  $P_i$  ainsi définie est polynomiale de degré  $i$  en chacune des variables  $y$ ,  $\chi$  et  $s$ .

Dans le cas rationnel les résultats de cette thèse sont tirés de [Mév23]. Pour des surfaces  $X_\Delta$  non-singulières, ils sont résumés dans l'énoncé suivant. Rappelons que  $\langle G_g(\Delta, s) \rangle_i$  est le coefficient de codegré  $i$  de  $G_g(\Delta, s)$ .

**Théorèmes 4.1.5 et 4.1.10.** *Soit  $i \in \mathbb{N}$  et  $s \in \mathbb{N}$ . Pour tout polygone  $\Delta$  non-singulier et  $h$ -transverse, si  $\Delta$  est assez grand alors*

$$\langle G_0(\Delta, s) \rangle_i = P_i(y(\Delta), \chi(\Delta), s).$$

La condition d'être *assez grand* est précisée dans ce manuscrit. Comme dans la conjecture de Göttsche, on note que le comportement des coefficients de l'invariant raffiné est donné par des polynômes  $P_i$  *universels*, dans le sens où ils ne dépendent pas de la surface considérée.

La démonstration de ce résultat se fait en deux temps. Dans [BJP22], Brugallé et Jaramillo-Puentes prouvent des résultats de polynomialité pour une famille de surfaces telles que la *divergence* des diagrammes en étages correspondants soit constante. On commence par adapter leur démonstration à une famille plus large de surfaces pour lesquelles la divergence n'est pas constante. Outre la non-singularité, cette famille est contrainte par une hypothèse d'*horizontalité* qui permet une description explicite des diagrammes en étages. Cette étape est le contenu du théorème 4.1.5. C'est ici que l'on obtient les formules explicites pour les séries génératrices et les polynômes  $P_i$ .

La deuxième étape consiste à enlever cette hypothèse d'horizontalité. Pour cela, on construit une correspondance entre les invariants raffinés  $G_0(\Delta, s)$  et  $G_0(\tilde{\Delta}, s)$ , où  $\tilde{\Delta}$  est obtenue par *éclatement* de  $\Delta$ , c'est-à-dire que la surface torique  $X_{\tilde{\Delta}}$  est un éclatement de  $X_\Delta$ . En étudiant dans la proposition 4.1.6 comment changent les diagrammes en étages lorsqu'on passe de  $\Delta$  à  $\tilde{\Delta}$ , on obtient le résultat suivant.

**Corollaire 4.1.7.** *Soit  $i \in \mathbb{N}$  et  $s \in \mathbb{N}$ . Si  $\Delta$  et  $\tilde{\Delta}$  sont tous les deux assez grands, alors on a l'équivalence*

$$\begin{aligned} & \forall k \in \{0, \dots, i\}, \langle G_0(\Delta, s) \rangle_k = P_k(y(\Delta), \chi(\Delta), s) \\ \Leftrightarrow & \forall k \in \{0, \dots, i\}, \langle G_0(\tilde{\Delta}, s) \rangle_k = P_k(y(\tilde{\Delta}), \chi(\tilde{\Delta}), s). \end{aligned}$$

Étant donné un polygone non-singulier, on peut par éclatements et contractions le lier à un polygone non-singulier horizontal. La correspondance ci-dessus permet donc de retirer l'hypo-

thèse d'horizontalité et d'obtenir le théorème 4.1.10. En particulier, un triangle qui définit le plan projectif  $\mathbb{CP}^2$ , voir exemple 2.1.12, ne satisfait pas l'horizontalité du théorème 4.1.5 mais entre dans le cadre du théorème 4.1.10.

On adapte ensuite la démonstration du théorème 4.1.5 au cas des surfaces singulières. Cela nécessite de prendre en compte le nombre  $n_k(\Delta)$  de singularités d'indice  $k$  de  $X_\Delta$ . Étant donné des entiers  $y, s, n_1, n_2, \dots$ , on considère

$$\sum_{i \geq 0} Q_i(y, s, n_1, n_2, \dots) x^i := A^{y-2-2s} B^s \prod_{k \geq 1} P(x^k)^{n_k}.$$

La fonction  $Q_i$  est polynomiale de degré  $i$  en les variables  $y$  et  $s$ , et de degré au plus  $i/k$  en chacune des variables  $n_k$ .

**Théorème 4.1.11.** *Soit  $i \in \mathbb{N}$  et  $s \in \mathbb{N}$ . Pour tout polygone  $\Delta$  horizontal et  $h$ -transverse, si  $\Delta$  est assez grand alors*

$$\langle G_0(\Delta, s) \rangle_i = Q_i(y(\Delta), s, n_1(\Delta), \dots).$$

Si  $\Delta$  est non-singulier on a  $n_k(\Delta) = 0$  si  $k \neq 1$  et  $n_1(\Delta) = \chi(\Delta)$ . On retrouve donc le théorème 4.1.5 dans ce cas. Notons que le terme  $\prod_{k \geq 2} P(x^k)^{n_k}$ , qui prend en compte les singularités, est le même que celui qui apparaît dans [LO18, corollaire 1.10]. Ceci est d'autant plus surprenant que Liu et Osserman travaillent à nombre de points doubles fixé, alors que ce manuscrit se place dans le cadre dual on l'on fixe le genre. Il serait intéressant d'étudier plus en détails ce phénomène.

Comme dans le cas non-singulier, on peut décrire ce qu'il se passe sous l'effet d'un éclatement. Cependant, la correspondance obtenue n'est pas suffisante pour retirer l'hypothèse d'horizontalité dans le cadre singulier, car les éclatements et contractions ne sont pas toujours suffisants pour se ramener à un polygone horizontal.

Pour finir avec le cas du genre 0, on reformule ensuite les résultats précédents en termes d'invariants raffinés asymptotiques, qu'on note  $AR_{g,s}^{\mathcal{F}}$  où  $\mathcal{F}$  est un éventail. L'invariant raffiné asymptotique est une fonction qui à un polygone  $\Delta$  dual à  $\mathcal{F}$  associe une série formelle, dont les premiers coefficients correspondent à ceux de l'invariant tropical raffiné. C'est une façon pratique de présenter les résultats et de simplifier les formules, qui a été introduite dans [BM24]. Dans ce contexte, le théorème 4.1.5 s'écrit ainsi.

**Théorème 4.2.24.** *Soit  $\mathcal{F}$  un éventail non-singulier, horizontal et  $h$ -transverse, et soit  $s \in \mathbb{N}$ . L'invariant raffiné asymptotique de genre 0 est donné par*

$$AR_{0,s}^{\mathcal{F}}(\Delta) = P(x)^{\chi(\Delta)}$$

où  $\Delta$  est un polygone dual à  $\mathcal{F}$ .

Bien que cette formulation soit équivalente à celle du théorème 4.1.5, on prouve ce résultat

indépendamment de ce qui précède. Cela permet de présenter des idées qui seront utilisées pour traiter le cas du genre 1. Rapidement, plutôt que de déterminer les diagrammes en étages puis de calculer leurs *nombres de marquages*, il s'agit de décrire directement les diagrammes en étages *marqués*. On les encode pour cela grâce à des *mots* auxquels on associe des multiplicités, qu'il faut ensuite sommer.

### Le cas du genre 1

L'étude en genre 1 est plus difficile que celle en genre 0. Cela est dû au fait que les diagrammes en étages correspondants sont plus compliqués à décrire. Néanmoins, avec le vocabulaire des invariants raffinés asymptotiques on peut montrer le résultat suivant, issu de [BM24] pour le cas où  $s = 0$ .

**Théorème 5.3.7.** *Soit  $\mathcal{F}$  un éventail non-singulier, horizontal et  $h$ -transverse, et soit  $s \in \mathbb{N}$ . L'invariant raffiné asymptotique de genre 1 est donné par*

$$AR_{1,s}^{\mathcal{F}}(\Delta) = P(x)^{\chi(\Delta)} \left( g_{\max}(\Delta) + 2s \frac{x}{1-x} - 12E_2(x) \right),$$

où  $\Delta$  est un polygone dual à  $\mathcal{F}$ ,  $g_{\max}(\Delta)$  est le genre maximale d'une courbe définie par  $\Delta$ , et où  $E_2(x) = \sum_{n \geq 1} \sigma_1(n)x^n$  avec  $\sigma_1(n) = \sum_{d|n} d$ .

L'idée est de relier les diagrammes de genre 1 à ceux de genre 0, en construisant les uns à partir des autres. Ceci établit une correspondance qui permet de ramener l'énumération à celle de diagrammes de genre 0, avec toutefois une multiplicité différente de celle utilisée précédemment. Cette technique est rendue possible par le fait que sous l'hypothèse que les polygones soient *assez grands*, on peut décrire explicitement les diagrammes de genre 0, comme dans la démonstration du théorème 4.1.5.

### Et en genre plus grand ?

Si on augmente encore le genre, les diagrammes en étages sont de plus en plus intriqués et compliqués à décrire. Les approches utilisées dans cette thèse vont atteindre une limite technique. S'il est incertain qu'on puisse en tirer des formules explicites, des idées similaires pourraient néanmoins montrer que les invariants raffinés asymptotiques ont la forme générale suivante.

**Conjecture 5.3.8.** *Soit  $\mathcal{F}$  un éventail non-singulier et  $h$ -transverse,  $g \in \mathbb{N}$  et  $s \in \mathbb{N}$ . L'invariant raffiné asymptotique de genre  $g$  a la forme suivante :*

$$AR_{g,s}^{\mathcal{F}}(\Delta) = P(x)^{\chi(\Delta)} \left( \binom{g_{\max}(\Delta)}{g} + Q_g^{\mathcal{F}}(\Delta, s) \right),$$

où  $\Delta$  est un polygone dual à  $\mathcal{F}$ , et où  $Q_g^{\mathcal{F}}$  est un polynôme de degré au plus  $g$  en les variables

$\mathcal{L}_\Delta^2$ ,  $\mathcal{L}_\Delta \cdot K_{X_\Delta}$  et  $s$ , dont les coefficients sont des séries formelles en  $x$  qui s'annulent en 0.

## 4 Série génératrice à codegré fixé

Dans une dernière partie, on s'intéresse aux coefficients de degrés fixés des invariants raffinés asymptotiques, et on forme leur série génératrice en sommant sur le genre. Par exemple, d'après [IM13] on sait que le coefficient dominant de l'invariant tropical raffiné  $G_g(\Delta)$  est  $\binom{g_{\max}(\Delta)}{g}$ , où  $g_{\max}(\Delta) = 1 + \frac{1}{2}(\mathcal{L}_\Delta^2 + \mathcal{L}_\Delta \cdot K_{X_\Delta})$ . Autrement dit, le terme constant de l'invariant raffiné asymptotique est

$$(AR_{g,s}^{\mathcal{F}}(\Delta))_0 = \binom{g_{\max}(\Delta)}{g}.$$

On a donc

$$\sum_{g \geq 0} (AR_{g,s}^{\mathcal{F}})_0 u^g = (1 + u)^{g_{\max}}.$$

Dans [BM24], nous donnons pour  $s = 0$  une formule pour la série génératrice des coefficients de degré 1 des invariants raffinés asymptotiques, autrement dit des coefficients de codegré 1 des invariants tropicaux raffinés. Pour  $s \neq 0$ , on a le résultat suivant.

**Théorème 6.3.1.** *Soit  $\mathcal{F}$  un éventail non-singulier, horizontal et  $h$ -transverse. La série génératrice des termes de degré 1 de l'invariant raffiné asymptotique est*

$$\sum_{g \geq 0} (AR_{g,s}^{\mathcal{F}})_1 u^g = (1 + u)^{g_{\max}} \left[ (\chi + 2su) \frac{1}{1 + u} - (u\mathcal{L} - K)^2 \frac{u}{(1 + u)^3} \right]$$

où  $\mathcal{L} : \Delta \mapsto \mathcal{L}_\Delta$  et  $K : \Delta \mapsto K_{X_\Delta}$ . En particulier, les fonctions qui donnent les coefficients de degré 1 sont polynomiales en  $\mathcal{L}_\Delta^2$ ,  $K_{X_\Delta}^2$ ,  $y(\Delta) = -\mathcal{L}_\Delta \cdot K_{X_\Delta}$ ,  $\chi(\Delta)$  et  $s$ .

Pour montrer ce résultat on décrit en tous genres les diagrammes de codegré 0 et 1, qui sont les seuls à intervenir dans le calcul de  $(AR_{g,s}^{\mathcal{F}})_1$ . On détermine explicitement les termes de degré 1 de leurs multiplicités, ce qui nous donne la série génératrice.

# Introduction

---

This thesis settles in the context of the enumerative geometry of algebraic curves on surfaces. It is dedicated to the study of tropical refined invariants, especially in genus 0 and 1. We prove the existence and give explicit formulas for formal series that asymptotically give the coefficients of the tropical refined invariants. We start with a historical review of the enumerative questions related to curves on surfaces, before exposing our results.

## 1.1 Algebraic enumerative geometry

### 1.1.1 Complex enumeration

It is an ancestral question to determine how many lines pass through two distinct points on the plane. Although the answer is easy<sup>1</sup>, this question generalizes to many interesting and more difficult problems. One can for instance ask for the number of curves of a given degree  $d$  passing through  $\frac{d(d+3)}{2}$  points on the plane. The number  $\frac{d(d+3)}{2}$  may seem to be chosen at random, but it is actually the dimension of the space of degree  $d$  curves, and thus the appropriate number of conditions to fix to get a finite but non-zero number of curves.

One can make the question more complex by considering other types of conditions to impose on the curves. A generic singular curve has only nodes as singularities, and we can prescribe the number of nodes. We then introduce a new parameter  $\delta$ , and look for the number of degree  $d$  irreducible curves having  $\delta$  nodes and passing through  $\frac{d(d+3)}{2} - \delta$  points on the plane. If the base field is  $\mathbb{C}$ , this number does not depend on the configuration on points we choose. We denote it by  $N^\delta(d)$ .

A dual point of view is the following. The *genus* of a nodal curve of degree  $d$  is the number of nodes it *does not* have. By the adjunction formula, the genus  $g$  and the number of nodes  $\delta$  of a nodal curve of degree  $d$  satisfy

$$g + \delta = \frac{(d-1)(d-2)}{2}.$$

Thus, we can consider the dual question of determining of many curves of degree  $d$  and genus

---

1. If you are wondering, the answer is 1 ;).



$g$  pass through  $3d - 1 + g$  points on the plane. Again, over the complex numbers  $\mathbb{C}$  it does not depend on the choice of the points, and we denote by  $N_g(d)$  this number.

The values of  $N^\delta(d)$  or  $N_g(d)$  for  $d = 1, 2$  are known since the antiquity, but in general it is very difficult to determine these numbers. Zeuthen computed  $N_0(4) = 620$  in 1873 [Zeu73], and very few more was known as the beginning of the XXth century.

More than one century after Zeuthen, Kontsevich proved a recursive formula to compute  $N_0(d)$  [KM94]. Few years later, Caporaso and Harris found another recursive formula that allows to compute all the  $N_g(d)$  [CH98]. At the dawn of the XXIst century, complete answers were finally known.

The question can be generalized to other surfaces. Consider  $X$  a complex algebraic and non-singular surface, and let  $\mathcal{L}$  be a sufficiently ample line bundle over  $X$ . Curves on  $X$  can be defined as the zero-sets of sections of  $\mathcal{L}$ . Given a non-negative integer  $\delta$ , we can wonder what is the number of irreducible curves on  $X$  with  $\delta$  nodes passing through  $\frac{\mathcal{L}^2 + c_1(X) \cdot \mathcal{L}}{2} - \delta$  points in generic position. This number  $N^\delta(\mathcal{L})$  is known as the *Severi degree*.

In this setting, if a nodal curve has  $\delta$  nodes and geometric genus equal to  $g$ , then the adjunction formula writes

$$g + \delta = \frac{\mathcal{L}^2 - c_1(X) \cdot \mathcal{L} + 2}{2}.$$

Hence one can also consider the number  $N_g(\mathcal{L})$  of curves on  $X$  of genus  $g$  and passing through  $c_1(X) \cdot \mathcal{L} - 1 + g$  points. The numbers  $N_g(\mathcal{L})$  also correspond to some Gromov-Witten invariants. Let us mention the Abramovich-Bertram formula [AB01], which relates rational Severi degrees of the Hirzebruch surfaces  $\mathbb{F}_0$  and  $\mathbb{F}_2$ . This formula has been generalized by Vakil in any genus [Vak00], and by Brugallé and Puignaux in a symplectic framework [BP15].

### 1.1.2 Polynomiality and Göttsche's conjecture

Instead of determining exactly the numbers of curves satisfying some conditions, one can study the behavior of these numbers when the parameters vary.

For fixed  $\delta$ , Di Francesco and Itzykson conjectured in [DFI95] the function  $d \mapsto N^\delta(d)$  to be polynomial for  $d$  large enough. This conjecture has been proven by Fomin and Mikhalkin using tropical methods [FM10], see section 1.2. They also showed that the polynomiality behavior holds for  $d \geq 2\delta$ . The function  $N^\delta$  is then called a *node polynomial*. For  $\delta = 1, 2, 3$  the node polynomials were known in the second half of the XIXth century. They have been computed up to  $\delta = 6$  by Vainsencher [Vai95],  $\delta = 8$  by Kleiman and Piene [KP04], and  $\delta = 14$  by Block [Blo11]. Block also improved the threshold of polynomiality to  $d \geq \delta$ .

In [Göt98], Göttsche widened the scope of Di Francesco and Itzykson's conjecture. He conjectured that for any non-negative integer  $\delta$ , there exists a polynomial  $P_\delta \in \mathbb{C}[x, y, z, t]$  such that for any non-singular complex algebraic surface  $X$  and for any line bundle  $\mathcal{L}$  sufficiently ample,

one has

$$N^\delta(\mathcal{L}) = P_\delta(\mathcal{L}^2, c_1(X) \cdot \mathcal{L}, c_1(X)^2, c_2(X)).$$

Moreover, the generating series of the sequence  $(P_\delta)_\delta$  was conjectured to be multiplicative, i.e. there exist some universal power series  $B_1, \dots, B_4 \in \mathbb{Q}[[u]]$  such that

$$\sum_{\delta \geq 0} P_\delta(x, y, z, t) u^\delta = B_1^x B_2^y B_3^z B_4^t.$$

He also gave some explicit descriptions for some of the  $B_i$  in terms of quasi-modular forms. Göttsche's conjecture is now a theorem. It has been proven first by Tzeng [Tze12]. Kool, Shende and Thomas then gave an alternative proof [KST11].

In the dual setting where the genus  $g$  is fixed instead of the number of nodes, Di Francesco and Itzykson showed the asymptotic  $\ln(N_0(d)) \sim 3d \ln(d)$  [DFI95]. Hence we cannot hope for the numbers  $N_g(\mathcal{L})$  to behave polynomially when  $g$  is fixed and  $\mathcal{L}$  varies.

### 1.1.3 Real enumeration

Instead of counting curves on the *complex* plane, one can look at curves on the *real* plane. There is still one line passing through two distinct points, and one conic passing through five points in generic position. However, if one wonders how many cubics of genus 0 (i.e. with 1 node) pass through 8 points on the real plane, trouble starts to appear. Indeed, contrary to the complex case this number depends on the configuration of points we choose. Degtyarev and Kharlamov showed there could be 8, 10 or 12 such real cubics [DK00].

Actually, for a complex nodal curve there is a unique type of node : a node is the intersection of two branches, and thus locally looks like  $x^2 - y^2 = 0$ . For a real nodal curve, two possibilities occur : the node can be the intersection of two real branches, or of two complex branches. In the first case a local equation is  $x^2 - y^2 = 0$  and we call it an *hyperbolic node*, while in the second case a local equation is  $x^2 + y^2 = 0$  and we speak about *elliptic node*. Degtyarev and Kharlamov showed that when counting real cubics through 8 given real points, the number of curves with an hyperbolic node minus the number of curves with an elliptic node is always 8 : this count does not depend anymore on the configuration of points we choose.

Welschinger generalized this observation [Wel05]. Consider a configuration of  $3d - 1$  real points, and let  $\mathcal{C}$  be a degree  $d$  rational curve through these points. Let  $n$  be the number of elliptic nodes of  $\mathcal{C}$  and define the Welschinger sign of  $\mathcal{C}$  to be  $(-1)^n$ . Welschinger proved that counting the degree  $d$  rational curves through  $3d - 1$  real points with their signs leads to an invariant ; we denote it  $W(d)$ .

The Welschinger number  $W(d)$  provides a lower bound for  $N_0(d)$ , but it is not clear that this number is positive. However, Itenberg, Kharlamov and Shustin [IKS03] showed a non-trivial

and positive lower bound for  $W(d)$ . They also proved the logarithmic asymptotic  $\ln(W(d)) \sim \ln(N_0(d))$  in [IKS04], and a Caporaso-Harris type formula for Welschinger numbers [IKS09].

More generally, when choosing the configuration of points one can also pick some pairs of complex conjugated points. We can consider the signed number of rational curves of degree  $d$  passing to a real configuration of  $3d - 1$  points containing exactly  $s$  pairs of complex conjugated points. This number again does not depend on the configuration of points we choose.

However, this invariance when counting signed real curves is specific to the rational case. When the degree is  $d \geq 4$ , Welschinger noticed in his paper that the count was not invariant for curves with 1 node. Itenberg, Kharlamov and Shustin also showed it is not invariant when considering genus 1 curves.

## 1.2 Tropical enumerative geometry

### 1.2.1 Correspondence theorems

We saw that determining the numbers  $N_g(\mathcal{L})$  was a difficult problem. However, the emergence of tropical geometry provided new ways to compute these numbers at the beginning of the XXIst century. A significant and crucial breakthrough is Mikhalkin's correspondence theorem [Mik05]. This result turns an algebro-geometric question into a more combinatorial one. Roughly speaking, it states that counting algebraic curves on toric surfaces is the same as counting piecewise linear objects called *tropical curves* with some multiplicities. Mikhalkin also provides an algorithm to compute the number of curves on toric surfaces. Moreover, he gives a version of his correspondence theorem suitable to determine the Welschinger invariants when  $s = 0$ , i.e. when there is no pair of complex conjugated points in the configuration. This enumeration requires to consider another multiplicity for the tropical curves. This result has been extended by Shustin [Shu06] to the case  $s \geq 1$ .

Building on Mikhalkin's approach, one can tropically recover some of the results regarding these enumerative problems. For instance, Gathmann and Markwig gave a tropical proof of the Caporaso-Harris formula [GM07a] and of the Kontsevich formula [GM08]. Invariance of the tropical count when determining Severi degree, usually deduced from Mikhalkin's theorem, can be proven tropically [GM07b]. Gathmann, Markwig and Schroeter also introduced *broccoli curves* and *broccoli invariants* which match the Welschinger invariants [GMS13], giving a tropical proof of the invariance of this tropical count. Let us also mention the tropical proof of the Abramovich-Bertram formula by Franz and Markwig [FM11].

Counts of tropical curves also gives new results. The study of Welschinger invariants by Itenberg, Kharlamov and Shustin already mentioned [IKS03, IKS04, IKS09] is based on this approach. The tropical recipe that gives the Welschinger invariants also leads to some invariants in any genus, called *tropical Welschinger invariants* [IKS09]. Brugallé and Markwig generalized

the Abramovich-Bertram and Vakil's formulas to the Hirzebruch surfaces  $\mathbb{F}_n$  and  $\mathbb{F}_{n+2}$ , by working in the tropical world and using a correspondence theorem [BM16].

## 1.2.2 A new tool : floor diagrams

Following Mikhalkin's correspondence theorem, Brugallé and Mikhalkin gave a combinatorial method to compute these numbers for a certain class of toric surfaces in [BM07, BM08]. They reduced the enumeration of tropical curves to the enumeration of a certain type of graphs called *floor diagrams*, with some multiplicities. This is possible under a technical condition called *h-transversality*. These objects are central in this thesis, as all our proofs rely on their manipulation.

Floor diagrams or their derivatives have been used intensively in the past years. Fomin and Mikhalkin's combinatorial proof of the conjecture of Di Francesco and Itzykson relies on floor diagrams [FM10]. The computation of the node polynomials  $N^\delta$ , up to  $\delta = 14$ , by Block is based on ideas of the paper by Fomin and Mikhalkin. Ardila and Block extended the work of [FM10] and proved polynomiality results for families of toric surfaces [AB13]. An interesting outcome of their combinatorial approach is that it allows to also deal with singular surfaces for which the initial Göttsche conjecture does not say anything. Block, Colley and Kennedy considered a logarithmic version of a quantity introduced by Fomin and Mikhalkin to give a new proof for the multiplicativity stated in Göttsche's conjecture in the case of  $\mathbb{C}P^2$  [BCK14]. Motivated by this work, Liu recovered in [Liu16] the result of Block, Colley and Kennedy as a particular case of a more general theorem. Thanks to this theorem, Liu and Osserman completed in [LO18] the work of Ardila and Block, especially by clarifying the link with Göttsche conjecture and generalizing the statement to singular surfaces.

With the appropriate multiplicity, floor diagrams can also be used to study Welschinger invariants. One can recover the logarithmic asymptotic of  $W(d)$  [Bru08]. Arroyo, Brugallé and López de Medrano proved a Caporaso-Harris type formula to compute Welschinger invariants, for configurations of points potentially containing pairs of complex conjugated points [ABLdM10].

## 1.3 Refined enumerations

### 1.3.1 Block-Göttsche multiplicity

Both enumerations of tropical curves and floor diagrams work if one counts the objects with some multiplicities. Classically, two multiplicities are attached to a tropical curve or a floor diagram : a *complex* multiplicity allows to recover the complex count of curves, i.e. to determine Gromov-Witten invariants, while a *real* multiplicity leads to the real count of curves, i.e. to Welschinger invariants. Both these multiplicities are integers.

Block and Göttsche proposed to use a *refined* multiplicity, which is no longer an integer but a symmetric Laurent polynomial in a formal variable  $q$  [BG16b]. Adapting the proof of Gathmann

and Markwig of the invariance of tropical count [GM07b], Itenberg and Mikhalkin showed that the count with Block-Göttsche multiplicities also leads to an invariant [IM13], known as *tropical refined invariant*. We denote by  $G_g(\Delta)(q)$  the tropical refined invariant, where  $g$  is the genus and  $\Delta$  is the polygon which defines both the toric surface and the linear system in which we count the curves. When  $q = 1$  the Block-Göttsche multiplicity recovers the complex multiplicity, and for  $q = -1$  it gives the real multiplicity. Thus, the tropical refined invariant interpolates between complex and real enumerations of curves : plugging  $q = 1$  we get Gromov-Witten invariant, and plugging  $q = -1$  we get tropical Welschinger invariant.

In the rational case, Göttsche and Schroeter extended Block-Göttsche invariants and defined a *refined broccoli invariant* now taking into account the number  $s$  of pairs of complex conjugated points we fix in the points configuration [GS19]. These invariants are denoted by  $G_0(\Delta, s)(q)$  and correspond to Block-Göttsche invariants for  $s = 0$ . It now interpolates between the broccoli invariants of [GMS13], i.e. Welschinger invariants involving pairs of complex conjugated points, and genus 0 descendant Gromov-Witten invariants. Göttsche-Schroeter invariants appeared to be a particular case of some invariants defined by Blechman and Shustin [BS19]. Schroeter and Shustin generalized Göttsche-Schroeter invariants to genus 1 [SS18]<sup>2</sup>.

The computation of the tropical refined invariants is possible using the floor diagram algorithm, adapted to the refined setting by Block and Göttsche [BG16b]. The floor diagrams can also be used to compute the broccoli invariants in genus 0 from [GS19], see for instance [BJP22]. Using floor diagrams, Bousseau has shown that Block-Göttsche invariants satisfy the Abramovich-Bertram formula [Bou21], settling a conjecture of [Bru20].

### 1.3.2 Interpretations

Apart from the values at  $q = \pm 1$ , the meaning of tropical refined invariants in classical geometry remains quite mysterious. The main conjecture is the one of Göttsche and Shende [GS14]. It states that tropical refined invariants correspond to the refinement of the Euler characteristic by the Hirzebruch  $\chi_{-g}$ -genus for some relative Hilbert scheme. Some work in this direction has been accomplished by Nicaise, Payne and Schroeter [NPS18].

There are other interpretations. For instance, Mikhalkin established a link between genus 0 tropical refined invariants and a refined count of real curves [Mik17]. This has been generalized by Blomme [Blo23]. Through the change of variable  $q = e^{iu}$ , Bousseau related tropical refined invariants to a generating series of log Gromov-Witten invariants with insertion of a  $\lambda$ -class [Bou19]. This correspondence has been extended to the case of refined invariants from [GS19] and [BS19] in [KHSUK23]. In the results of Mikhalkin, Blomme, Bousseau and Kennedy-Hunt

---

2. Simultaneously and independently with this thesis, Shustin and Sinichkin proposed a generalization of the work of [SS18] to any genus [SS24]. They also showed that the evaluation at  $q = 1$  gives the number of curves satisfying some incidence and tangency conditions.

et al, it is interesting to note that the denominator of the tropical refined invariant seems to be in excess.

### 1.3.3 Polynomiality strikes back

Block and Göttsche showed that if we fix the number of nodes  $\delta$  then the coefficients of the tropical refined invariant are eventually polynomial [BG16b]. In other words, the polynomiality behaviour stated in Göttsche's conjecture passes down to the refined level.

More surprisingly, if we fix the genus  $g$  instead of the number of nodes  $\delta$  then Brugallé and Jaramillo-Puentes proved that we recover a polynomial behaviour [BJP22]. For a family of surfaces that includes the projective plane and Hirzebruch surfaces, the coefficients of small codegrees of the tropical refined invariant are asymptotically given by some polynomials. This is also the case for the Göttsche-Schroeter invariant. This raises the question of the existence of universal polynomials for these coefficients. Is there a Göttsche-like conjecture in this dual and refined setting ?

## 1.4 Results of this thesis

This thesis is mainly based on the papers [Mév23] and [BM24] and is devoted to the study of the tropical refined invariants defined by Block-Göttsche [BG16b] and Göttsche-Schroeter [GS19]. Chapter 3 combinatorially extends the Göttsche-Schroeter invariants in higher genus. Chapters 4 and 5 continue the study of the asymptotic polynomiality of the refined invariants, as started in [BJP22]. In the spirit of Göttsche's conjecture, the main results of this thesis give universal formulas for the coefficients of small codegrees of the refined invariants in the rational case (chapter 4) and in the genus 1 case (chapter 5). Chapter 6 is dedicated to the study of generating series in the genus parameter of the coefficients of codegree 0 and 1 of the refined invariant.

### 1.4.1 Göttsche-Schroeter invariants in higher genus

The calculation of Göttsche-Schroeter invariants  $G_0(\Delta, s)$  using floor diagrams requires to choose a *pairing*  $S$  of order  $s$ , see [BJP22, section 2.3] or section 2.2.2 of this thesis. However, the Göttsche-Schroeter invariant *does not* depend on the choice of this pairing, as long as it has order  $s$  by [BJP22, theorem 2.13], reproduced as theorem 2.2.16 in this manuscript. Namely, if  $S$  and  $S'$  are two pairings of order  $s$ , one can define the count of floor diagrams  $G_0(\Delta, S)$  and  $G_0(\Delta, S')$ , and show they are both equal to the Göttsche-Schroeter invariant  $G_0(\Delta, s)$  (this last notation is then an abuse of notation).

We give in this manuscript a combinatorial proof of this independence which is valid for any genus, not only in the rational case. For any genus  $g$  we define a quantity  $G_g(\Delta, S)$  as a count

of floor diagrams, and show it does not depend on  $S$  but only of its order.

**Theorem 3.1.3.** *Let  $\Delta$  be  $h$ -transverse polygon and  $g \in \mathbb{N}$ . Let  $s \in \mathbb{N}$  and  $S, S'$  be two pairings of order  $s$ . Then  $G_g(\Delta, S) = G_g(\Delta, S')$ . We can then write  $G_g(\Delta, s)$ .*

The proof is a study of several cases according to how the pairings  $S$  and  $S'$  interact with a floor diagram. It fulfills the wish of [BJP22, remark 2.14] to get a proof of the independence with respect to  $S$  that does not go through tropical geometry. Moreover, if the genus is  $g = 1$  then we can show that the combinatorial invariants defined here match the ones of [SS18]<sup>3</sup>.

We then prove few results on this *higher genus Göttsche-Schroeter invariant*  $G_g(\Delta, s)$ . Especially we show some polynomiality behavior with respect to  $s$ . The following theorem extends [BJP22, theorem 1.7] to arbitrary genus. Here,  $\langle G_g(\Delta, s) \rangle_i$  denotes the codegree  $i$  coefficient of  $G_g(\Delta, s)$ . Other notations are defined in sections 2.2.1 and 2.2.2.

**Theorem 3.1.8.** *Let  $\Delta$  be an  $h$ -transverse polygon and  $g \leq g_{\max}(\Delta)$ . If  $2i \leq e^{-\infty}(\Delta)$  and  $i \leq g_{\max}(\Delta)$ , then the values  $\langle G_g(\Delta, s) \rangle_i$  for  $0 \leq s \leq s_{\max}(\Delta, g)$  are interpolated by a polynomial of degree  $i$ , whose leading coefficient is  $\frac{(-2)^i}{i!} (g_{\max} - i)$ .*

We also perform computations on manageable examples which leads us to few conjectures. In particular the higher genus Göttsche-Schroeter invariants seem to satisfy the Abramovich-Bertam formula. The polygon  $\Delta_{a,b}^n$  defines the Hirzebruch surface  $\mathbb{F}_n$  together with the curves of bidegree  $(a, b)$ , see example 2.1.13.

**Conjecture 3.2.16, Abramovich-Bertram formula.** *Let  $a, b \in \mathbb{N}$  and  $g \geq 0$ . For any  $s \geq 0$  one has*

$$G_g(\Delta_{a,a+b}^0, s) = \sum_{j=0}^a \binom{b+2j}{j} G_g(\Delta_{a-j,b+2j}^2, s).$$

Although I do not know if these combinatorial invariants have a geometric meaning, if such a formula were true it would plea in favor of a geometric interpretation of  $G_g(\Delta, s)$ . This is a question to delve further into.

## 1.4.2 Polynomiality and universal generating series

Given the polynomiality results of Brugallé and Jaramillo-Puentes for coefficients of the tropical refined invariants [BJP22], and the polynomiality behavior stated in Göttsche’s conjecture for Severi degrees [Göt98, Tze12], one can wonder if there exist universal series that asymptotically give the coefficients of  $G_g(\Delta, s)$ . In this thesis we positively answer this question in the case of genus 0 and 1.

---

3. This is also true when considering the invariants of [SS24] in any genus, when the polygon  $\Delta$  is  $h$ -transverse.

### The rational case

In chapter 4 we study the genus 0 case. Let us introduce some notations before stating the results. A polygon  $\Delta$  defines a toric surface  $X_\Delta$  and a line bundle  $\mathcal{L}_\Delta$ . We denote  $y(\Delta) = c_1(X_\Delta) \cdot \mathcal{L}_\Delta$  and  $\chi(\Delta) = c_2(X_\Delta)$ . We consider the series

$$A(x) = \frac{1}{1-x}, \quad B(x) = \frac{1}{1-x^2}, \quad P(x) = \prod_{k \geq 1} \frac{1}{1-x^k},$$

and given three integers  $y$ ,  $\chi$  and  $s$  we consider

$$\sum_{i \geq 0} P_i(y, \chi, s) x^i := A^{y-2-2s} B^s P^\chi.$$

The function  $P_i$  is a polynomial and has degree  $i$  in each of the variables  $y$ ,  $\chi$  and  $s$ . Our main universality result in the rational case is the following, and appears in [Mév23]. It deals with non-singular toric surface defined by  $h$ -transverse polygons.

**Theorems 4.1.5 and 4.1.10.** *Let  $i \in \mathbb{N}$  and  $s \in \mathbb{N}$ . For any non-singular and  $h$ -transverse polygon  $\Delta$ , if  $\Delta$  is large enough then*

$$\langle G_0(\Delta, s) \rangle_i = P_i(y(\Delta), \chi(\Delta), s).$$

The *large enough* condition is made precise in sections 4.1.1 and 4.1.3. As in Göttsche's conjecture, it is interesting to note that the behavior of the coefficients of the refined invariants are given by some *universal polynomials*  $P_i$  in a multiplicative way. However, in Göttsche's conjecture the polynomial behavior is dictated by four topological numbers. Here, only two of them appear.

The outline of the proof is the following. We adapt the polynomiality proof of [BJP22] to a more general family of non-singular surfaces, only constrained by a hypothesis of *horizontality* of the polygons defining the surfaces, see theorem 4.1.5. We then build a correspondence between the refined invariants  $G_0(\Delta, s)$  and  $G_0(\tilde{\Delta}, s)$ , where  $\tilde{\Delta}$  is a *blow-up* of  $\Delta$ . This correspondence gives the following result.

**Corollary 4.1.7.** *Let  $i \in \mathbb{N}$  and  $s \in \mathbb{N}$ . If both  $\Delta$  and  $\tilde{\Delta}$  are large enough, then one has the equivalence*

$$\begin{aligned} \forall k \in \{0, \dots, i\}, \quad \langle G_0(\Delta, s) \rangle_k &= P_k(y(\Delta), \chi(\Delta), s) \\ \Leftrightarrow \forall k \in \{0, \dots, i\}, \quad \langle G_0(\tilde{\Delta}, s) \rangle_k &= P_k(y(\tilde{\Delta}), \chi(\tilde{\Delta}), s). \end{aligned}$$

Again, the *large enough* condition is made precise in section 4.1.2. Using this correspondence we are able to remove the horizontality hypothesis and to obtain theorem 4.1.10. In particular,



one can include the projective plane  $\mathbb{CP}^2$  in the range of surfaces covered by theorem 4.1.10 at the cost of this correspondence under blow-up.

In [Mév23] we also adapt the proof of theorem 4.1.5 to singular surfaces. This requires to take into account the number  $n_k(\Delta)$  of singularities of index  $k$  of  $X_\Delta$ . Given integers  $y, s, n_1, n_2, \dots$ , we consider the series

$$\sum_{i \geq 0} Q_i(y, s, n_1, n_2, \dots) x^i := A^{y-2-2s} B^s \prod_{k \geq 1} P(x^k)^{n_k}.$$

Note that  $Q_i$  is a polynomial of degree  $i$  in the variables  $y$  and  $s$ , and of degree at most  $i/k$  in each of the variables  $n_k$ .

**Theorem 4.1.11.** *Let  $i \in \mathbb{N}$  and  $s \in \mathbb{N}$ . For any  $h$ -transverse and horizontal polygon  $\Delta$ , if  $\Delta$  is large enough then*

$$\langle G_0(\Delta, s) \rangle_i = Q_i(y(\Delta), s, n_1(\Delta), \dots).$$

The *large enough* condition is made precise in section 4.1.4. If  $\Delta$  is non-singular one has  $n_k(\Delta) = 0$  unless  $k = 1$ , for which  $n_1(\Delta) = \chi(\Delta)$ . Hence we recover theorem 4.1.5 in that case. We note that the term  $\prod_{k \geq 2} P(x^k)^{n_k}$ , which takes into account the singularities, is the same as the one appearing in [LO18, corollary 1.10]. This is surprising, especially because Liu and Osserman work at fixed number of nodes while we work at fixed genus. It may worth investigate more precisely this phenomenon.

We do not know how to remove the horizontality hypothesis because a singular polygon is not as constraint as a non-singular one. We are able to describe what happens when we perform an operation similar to a blow-up, but it is not sufficient to reach any  $h$ -transverse polygon.

We then adopt the slightly different point of view of *asymptotic refined invariants*  $AR_{g,s}^{\mathcal{F}}$ , where  $\mathcal{F}$  is a fan. They are a practical way to rephrase the previous results on the tropical refined invariants. Roughly speaking, it consists in removing denominators and negative exponents in the tropical refined invariants, which turns codegrees into degrees and simplify the generating series, see section 2.3. With the vocabulary of [BM24], theorem 4.1.5 is rephrased as follows.

**Theorem 4.2.24.** *Let  $\mathcal{F}$  be an  $h$ -transverse, non-singular and horizontal fan, and let  $s \in \mathbb{N}$ . The genus 0 asymptotic refined invariant is*

$$AR_{0,s}^{\mathcal{F}}(\Delta) = P(x)^{\chi(\Delta)}$$

where  $\Delta$  is a polygon dual to  $\mathcal{F}$ .

We prove this theorem independently from theorem 4.1.5 to present ideas that will be used in chapter 5 for the genus 1 case. Note that a fan defining the projective plane  $\mathbb{CP}^2$  does not satisfied the hypothesis of theorem 4.2.24. Besides, we do not say anything on a correspondence under blow-up or on singular surfaces.

### The genus 1 case

In chapter 5 we study the genus 1 case. We use elements introduced in section 4.2 to prove the following, which appears in [BM24] for the case  $s = 0$ .

**Theorem 5.3.7.** *Let  $\mathcal{F}$  be an  $h$ -transverse, non-singular and horizontal fan, and let  $s \in \mathbb{N}$ . The genus 1 asymptotic refined invariant is*

$$AR_{1,s}^{\mathcal{F}}(\Delta) = P(x)^{\chi(\Delta)} \left( g_{\max}(\Delta) + 2s \frac{x}{1-x} - 12E_2(x) \right),$$

where  $\Delta$  is a polygon dual to  $\mathcal{F}$ , and  $E_2(x) = \sum_{n \geq 1} \sigma_1(n)x^n$  with  $\sigma_1(n) = \sum_{d|n} d$ .

The idea to get the genus 1 case is to construct floor diagrams of genus 1 from floor diagrams of genus 0, and to reduce the genus 1 enumeration to a rational enumeration with a different multiplicity. This is possible because under a *large enough* hypothesis, which is hidden in the definition of asymptotic refined invariants, one can easily and explicitly describe the genus 0 diagrams.

Although it is unlikely that this approach gives explicit results in higher genus, similar ideas could show that the asymptotic refined invariant has the following general form.

**Conjecture 5.3.8.** *Let  $\mathcal{F}$  be an  $h$ -transverse and non-singular fan,  $g \in \mathbb{N}$  and  $s \in \mathbb{N}$ . The asymptotic refined invariant  $AR_{g,s}^{\mathcal{F}}$  has the following form :*

$$AR_{g,s}^{\mathcal{F}}(\Delta) = P(x)^{\chi(\Delta)} \left( \binom{g_{\max}(\Delta)}{g} + Q_g^{\mathcal{F}}(\Delta, s) \right),$$

where  $\Delta$  is a polygon dual to  $\mathcal{F}$ , and where  $Q_g^{\mathcal{F}}$  is a polynomial of degree at most  $g$  in  $\mathcal{L}_{\Delta}^2$ ,  $\mathcal{L}_{\Delta} \cdot K_{X_{\Delta}}$  and  $s$ , whose coefficients are formal series in  $x$  that vanish at 0.

### 1.4.3 Generating series at fixed codegree

Last, in chapter 6 we fixed the codegree and sum over the genus parameter. It is known from [IM13] that the leading coefficient of the genus  $g$  tropical refined invariant, or equivalently the constant term of the asymptotic refined invariant, is

$$(AR_{g,s}^{\mathcal{F}}(\Delta))_0 = \binom{g_{\max}(\Delta)}{g}$$

where  $g_{\max}(\Delta) = 1 + \frac{1}{2}(\mathcal{L}_{\Delta}^2 + \mathcal{L}_{\Delta} \cdot K_{X_{\Delta}})$ . In other words, one has

$$\sum_{g \geq 0} (AR_{g,s}^{\mathcal{F}})_0 u^g = (1 + u)^{g_{\max}}.$$

In [BM24] we provide a formula for the degree 1 term of the asymptotic refined invariants for  $s = 0$ , i.e. for the codegree 1 term of the tropical refined invariants. For non-zero  $s$ , one has the following.

**Theorem 6.3.1.** *Let  $\mathcal{F}$  be an  $h$ -transverse, horizontal and non-singular fan. The generating series of the degree 1 terms of the asymptotic refined invariant is given by*

$$\sum_{g \geq 0} (AR_{g,s}^{\mathcal{F}})_1 u^g = (1+u)^{g_{\max}} \left[ (\chi + 2su) \frac{1}{1+u} - (u\mathcal{L} - K)^2 \frac{u}{(1+u)^3} \right]$$

where  $\mathcal{L} : \Delta \mapsto \mathcal{L}_{\Delta}$  and  $K : \Delta \mapsto K_{X_{\Delta}}$ . In particular, the asymptotic polynomials yielding the degree 1 coefficients are polynomials in  $\mathcal{L}_{\Delta}^2$ ,  $y(\Delta) = -K_{X_{\Delta}} \cdot \mathcal{L}_{\Delta}$ ,  $\chi(\Delta)$ ,  $K_{X_{\Delta}}^2$  and  $s$ .

# Preliminaries

---

In this chapter we review a bit of toric geometry, before introducing floor diagrams and refined invariants.

## 2.1 Toric surfaces

We briefly recall some notions of toric geometry, and introduce some notations and vocabulary. For more details regarding this subject, we refer to [Ful93] or [CLS11].

### 2.1.1 Cones and fans

Let  $N$  be a lattice of rank 2 and  $M = \text{Hom}(N, \mathbb{Z})$  its dual. We denote by  $M_{\mathbb{R}} = M \otimes \mathbb{R}$  and  $N_{\mathbb{R}} = N \otimes \mathbb{R}$  the associated real vector spaces. The pairing between  $N_{\mathbb{R}}$  and  $M_{\mathbb{R}}$  is denoted  $\langle \cdot, \cdot \rangle$ . In this text, we can always imagine  $N \simeq M \simeq \mathbb{Z}^2$  and  $N_{\mathbb{R}} \simeq M_{\mathbb{R}} \simeq \mathbb{R}^2$ .

Given a finite set  $A \subset N_{\mathbb{R}}$ , the *polyhedral cone generated by  $A$*  is

$$\sigma(A) = \left\{ \sum_{v \in A} \lambda_v v, \lambda_v \in \mathbb{R}_+ \right\} \subset N_{\mathbb{R}} \simeq \mathbb{R}^2.$$

A *cone* will be a set of this form. It is *strongly convex* if it does not contain any vector subspace of  $N_{\mathbb{R}} \simeq \mathbb{R}^2$  except  $\{0\}$ , and its dimension is the dimension of the vector space it spans.

The cone  $\sigma(A)$  is *rational* if the elements of  $A$  are lattice vectors, i.e.  $A \subset N \simeq \mathbb{Z}^2$ . A rational cone is *simplicial* if the elements of  $A$  are linearly independent over  $\mathbb{R}$ , and *non-singular* (or *unimodular*) if the elements of  $A$  are part of a basis of the lattice  $N \simeq \mathbb{Z}^2$ . Note that a simplicial cone is strongly convex.

Let  $\sigma$  be a two-dimensional rational cone generated by  $u \in \mathbb{Z}^2$  and  $v \in \mathbb{Z}^2$ , with  $u$  and  $v$  primitive. The *index* of  $\sigma$  is  $\text{ind}(\sigma) = |\det(u, v)|$ . Note that the cone  $\sigma$  is non-singular if and only if its index is 1.

**Definition 2.1.1.** A fan  $\mathcal{F}$  in  $N_{\mathbb{R}} \simeq \mathbb{R}^2$  is a finite collection of rational and strongly convex cones, such that pairwise intersections of cones of  $\mathcal{F}$  are cones of  $\mathcal{F}$ . The 1-dimensional cones of  $\mathcal{F}$  are called the rays. A fan is simplicial (resp. non-singular) if any of its cones is.

In this text, any fan  $\mathcal{F}$  will be *complete*, i.e. its support is the whole ambient vector space :

$$\bigcup_{\sigma \in \mathcal{F}} \sigma = N_{\mathbb{R}} \simeq \mathbb{R}^2.$$

*Example 2.1.2.* The fan  $\mathcal{F}_{\mathbb{CP}^2}$  of figure 2.1a is formed by seven cones : the 0-dimensional cone  $\{0\}$ , the three rays generated respectively by  $(-1, 0)$ ,  $(0, -1)$  and  $(1, 1)$ , and the three 2-dimensional cone generated by the pairs of the previous vectors.

The fan  $\mathcal{F}_n$  of figure 2.1b has one 0-dimensional cone, four rays and four 2-dimensional cones. Both  $\mathcal{F}_{\mathbb{CP}^2}$  and  $\mathcal{F}_n$  are non-singular fans.

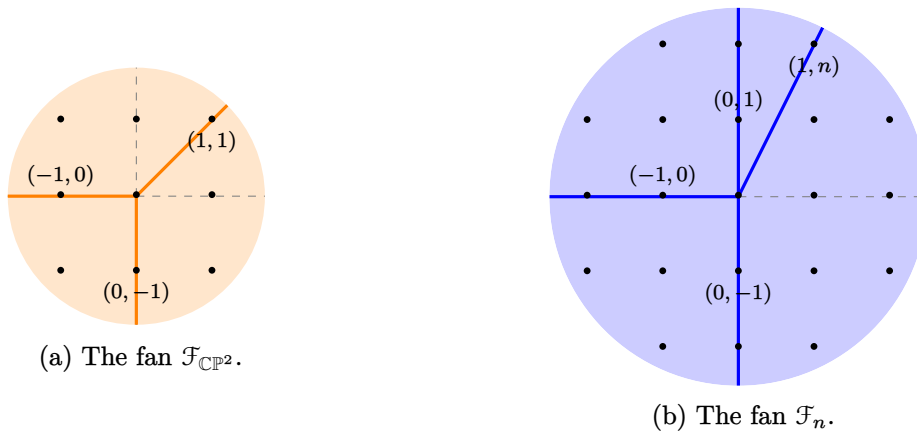

Figure 2.1 – Examples of fans.

### 2.1.2 Polygons and duality

Given a finite set  $A \subset M_{\mathbb{R}}$ , the *polytope defined by A* is the convex hull

$$\Delta_A = \text{conv}(A) \subset M_{\mathbb{R}} \simeq \mathbb{R}^2.$$

It is *rational* if its vertices are lattice points, i.e. we can choose  $A \subset M \simeq \mathbb{Z}^2$ .

**Definition 2.1.3.** A polygon  $\Delta$  in  $M_{\mathbb{R}} \simeq \mathbb{R}^2$  is a *rational polytope*.

*Remark 2.1.4.* In particular, note that a polygon is convex.

A vector  $u \in N_{\mathbb{R}} \simeq \mathbb{R}^2$  of the dual space and a real number  $b \in \mathbb{R}$  determine an affine hyperplane

$$H_{u,b} = \{x \in M_{\mathbb{R}} \mid \langle x, u \rangle = b\}$$

and a negative half-space

$$H_{u,b}^- = \{x \in M_{\mathbb{R}} \mid \langle x, u \rangle \leq b\}.$$

**Definition 2.1.5.** A face of a polytope  $\Delta$  is a subset  $F \subset \Delta$  such that

$$F = \Delta \cap H_{u,b} \quad \text{and} \quad \Delta \subset H_{u,b}^-$$

for some  $u \in N_{\mathbb{R}}$  and  $b \in \mathbb{R}$ . The vector  $u$  is then called an outward normal vector of the face  $F$ . A facet is a face of codimension 1.

Let  $\Delta$  be a polygon. Then  $\Delta$  is rational so any face of  $\Delta$  admits an outward normal vector in  $N \simeq \mathbb{Z}^2$ . For any facet  $F$  of  $\Delta$ , let  $u_F \in N$  be an outward normal vector of  $F$ . For a face  $P$  of  $\Delta$  we define the dual cone  $\sigma_P = \sigma(u_F, P \subset F) \subset N_{\mathbb{R}}$ .

**Definition 2.1.6.** Let  $\Delta$  be a polygon. The dual fan (or outer normal fan) of  $\Delta$  is

$$\mathcal{F}(\Delta) = \{\sigma_P, P \text{ face of } \Delta\} \subset N_{\mathbb{R}}.$$

Conversely, if  $\mathcal{F} \subset N_{\mathbb{R}}$  is a fan we denote

$$D(\mathcal{F}) = \{\Delta \subset M_{\mathbb{R}} \mid \mathcal{F}(\Delta) = \mathcal{F}\}$$

the set of polygons dual to  $\mathcal{F}$ .

*Remark 2.1.7.* One can instead consider the positive half-space  $H_{u,b}^+$ , defined by  $\langle x, u \rangle \geq b$  as in [CLS11]. It does not change the definition of face, but turns outward normal vector into inward normal vector, and outer normal fan into inner normal fan. The constructions are equivalent and the choice is only a matter of convention.

By duality, vocabulary on cones and fans transfers to the polygons. In particular, a polygon  $\Delta$  is *simplicial* or *non-singular* if its dual fan is. Moreover, if  $P$  is a vertex of  $\Delta$  then  $\sigma_P$  is a two dimensional cone, and the *index* of  $P$  is  $\text{ind}(P) = \text{ind}(\sigma_P)$ .

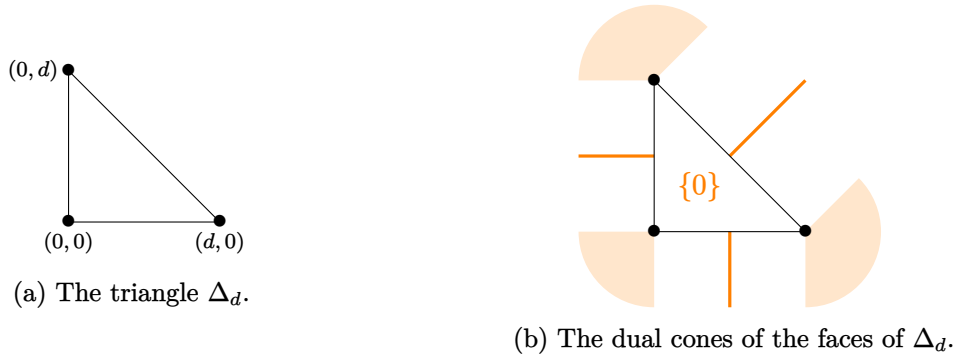

Figure 2.2

*Example 2.1.8.* Let  $\Delta_d = \text{conv}(\{(0,0), (d,0), (0,d)\})$  be the triangle of figure 2.2a. Let  $u = (1,1) \in \mathbb{Z}^2$  and  $b = d$ . Then  $H_{u,b} = \{x + y = d\}$  and the edge  $[(d,0), (0,d)]$  is a face of  $\Delta_d$ , with

outward normal vector  $(1, 1)$ . Actually it is a facet of the triangle. The other facets are the edges  $[(0, 0), (d, 0)]$  and  $[(0, 0), (0, d)]$  with outer normal vectors  $(0, -1)$  and  $(-1, 0)$ .

The vertex  $(d, 0)$  is a face of  $\Delta_d$  (take for instance  $u = (1, 0)$  and  $b = d$ ) but not a facet. Its dual cone is  $\sigma_{(d,0)} = \sigma((-1, 0), (1, 1))$ . Others 0-dimensional faces are the vertices  $(0, 0)$  and  $(0, d)$ . The triangle  $\Delta_d$  is itself a face (with  $u = (0, 0)$  and  $b = 0$ ) ; its dual cone is just  $\{0\}$ .

On figure 2.2b we represent the faces of  $\Delta_d$  together with a visualisation of their dual cones. Note that this drawing is not exact, since the polygon and the cones live in dual spaces ; also, the cones should have  $(0, 0)$  as apex. Hence the dual fan of  $\Delta_d$  is the fan  $\mathcal{F}_{\mathbb{C}P^2}$  of figure 2.1a.

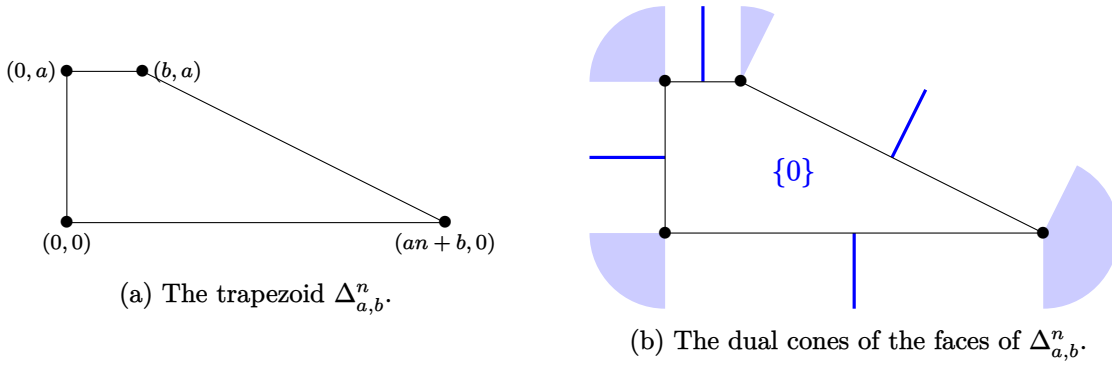

Figure 2.3

*Example 2.1.9.* Let  $\Delta_{a,b}^n = \text{conv}(\{(0, 0), (an + b, 0), (b, a), (0, a)\})$  be the trapezoid of figure 2.3a. On figure 2.3b we represent the faces of  $\Delta_{a,b}^n$  together with a visualisation of their dual cones. Hence the dual fan of  $\Delta_{a,b}^n$  is the fan  $\mathcal{F}_n$  of figure 2.1b.

### 2.1.3 Toric surfaces and linear systems

Following [Ful93] or [CLS11], a complete fan  $\mathcal{F} \subset N_{\mathbb{R}}$  gives a (compact) *toric surface*  $X_{\mathcal{F}}$ . It is called *toric* because it is equipped with the action of an algebraic torus it contains as an open subset. There is a important dictionary between the properties and elements of the fan  $\mathcal{F}$  and the ones of the toric variety  $X_{\mathcal{F}}$ . We briefly recall some of these correspondences.

- ▷ The toric surface  $X_{\mathcal{F}}$  can only have a finite number of singular points, and these points correspond to the vertices of a polygon  $\Delta$  dual to  $\mathcal{F}$ , i.e. to the fixed points of the torus action. Moreover, the point of  $X_{\mathcal{F}}$  corresponding to the vertex  $P$  of  $\Delta$  is a singularity if and only if  $\text{ind}(P) > 1$ , and in that case it is a singularity of index  $\text{ind}(P)$ , see [LO18, proposition A.1] or [CLS11, section 10.1]. In particular, the surface  $X_{\mathcal{F}}$  is non-singular if and only if the fan  $\mathcal{F}$  is non-singular, if and only if any cone of  $\mathcal{F}$  is unimodular.
- ▷ The topological Euler characteristic  $\chi(X_{\mathcal{F}})$  is the equal to the number of 2-dimensional cones of  $\mathcal{F}$ .

- ▷ There is a correspondence between the cones of  $\mathcal{F}$  and the orbits of the torus action on  $X_{\mathcal{F}}$ , see [CLS11, section 3.2] or [Ful93, section 3.1].
- ▷ The toric prime divisors of  $X_{\mathcal{F}}$  are in bijection with the rays of  $\mathcal{F}$ . The anti-canonical class  $-K_{X_{\mathcal{F}}}$  is represented by the sum of the toric prime divisors, see [CLS11, theorem 8.2.3].

*Example 2.1.10.* The fan  $\mathcal{F}_{\mathbb{CP}^2}$  of figure 2.1a defines the projective plane  $\mathbb{CP}^2$ . This is a non-singular surface and one can check that the fan  $\mathcal{F}_{\mathbb{CP}^2}$  is indeed non-singular. Moreover,  $\chi(\mathbb{CP}^2) = 3$  is the number of 2-dimensional cones of  $\mathcal{F}_{\mathbb{CP}^2}$ .

*Example 2.1.11.* The fan  $\mathcal{F}_n$  of figure 2.1b defines the Hirzebruch surface  $\mathbb{F}_n$ . This is a non-singular surface and one can check that the fan  $\mathcal{F}_n$  is indeed non-singular. Moreover,  $\chi(\mathbb{F}_n) = 4$  is the number of 2-dimensional cones of  $\mathcal{F}_n$ .

The toric surface  $X_{\mathcal{F}}$  is usually defined from the fan  $\mathcal{F}$ . Obviously, given a polygon  $\Delta$  it defines a toric surface through its dual fan. Hence, we will indifferently denote toric surfaces by  $X_{\mathcal{F}}$  or  $X_{\Delta}$ . However, remembering the polygon instead of the fan can be interesting in several situations. Indeed, a polygon  $\Delta$  actually defines a *polarized toric surface*, i.e. a toric surface  $X_{\Delta}$  equipped with a line bundle  $\mathcal{L}_{\Delta}$ . A basis of sections of  $\mathcal{L}_{\Delta}$  is indexed by the lattice points of  $\Delta$ . The line bundle  $\mathcal{L}_{\Delta}$  itself defines a *linear system* on  $X_{\Delta}$ , i.e. a set of curves : a *curve* is the zero-set of a section of  $\mathcal{L}_{\Delta}$ .

*Example 2.1.12.* The triangle  $\Delta_d$  of figure 2.2a is dual to the fan of figure 2.1a, hence it defines  $\mathbb{CP}^2$ . The associated line bundle is  $\mathcal{L}_{\Delta_d} = \mathcal{O}(d)$  on  $\mathbb{CP}^2$ , thus the corresponding linear system is the curves of degree  $d$  on  $\mathbb{CP}^2$ . These curves form the homology class  $dL \in H_2(\mathbb{CP}^2, \mathbb{Z}) \simeq \mathbb{Z}$ , where  $L$  is the class of any line.

*Example 2.1.13.* The trapezoid  $\Delta_{a,b}^n$  of figure 2.3a is dual to the fan of figure 2.1b, hence it defines the Hirzebruch surface  $\mathbb{F}_n$ . Let  $F$ ,  $E = E_0$  and  $E_{\infty}$  be the classes of the divisors associated to rays generated by  $(-1, 0)$ ,  $(0, -1)$  and  $(0, 1)$ . Because of the relation

$$E_{\infty} = E_0 - nF$$

the homology group  $H_2(\mathbb{F}_n, \mathbb{Z})$  is generated by  $E$  and  $F$ . The linear system associated to  $\Delta_{a,b}^n$  corresponds to the curves with homology class  $aE + bF$ , i.e. of bidgree  $(a, b)$ .

The dictionary between fans and toric surfaces transposes to the setting of polygons. In particular the anti-canonical divisor  $-K_{X_{\Delta}}$  is the sum of the toric prime divisors, which correspond to the edges of  $\Delta$ . Moreover, the intersection number  $-K_{X_{\Delta}} \cdot \mathcal{L}_{\Delta}$  between the anti-canonical divisor and any curve of the linear system associated to  $\mathcal{L}_{\Delta}$  is

$$-K_{X_{\Delta}} \cdot \mathcal{L}_{\Delta} = |\partial\Delta \cap \mathbb{Z}^2|.$$



By Kouchnirenko’s theorem, see [GKZ94, section 6.2], the auto-intersection  $\mathcal{L}_\Delta^2$  of curves of the linear system is

$$\mathcal{L}_\Delta^2 = 2\text{Area}(\Delta).$$

By the genus formula (derived from the adjunction formula, see [CLS11, theorem 10.5.1], [Sha13, theorem 6.4] or [GH94, section 4.1]), if  $X_\Delta$  is non-singular then the maximal genus of a curve in the linear system is

$$g_{\max} = \frac{\mathcal{L}_\Delta^2 + K_{X_\Delta} \cdot \mathcal{L}_\Delta + 2}{2}.$$

By Pick’s formula this turns to be

$$g_{\max} = |\mathring{\Delta} \cap \mathbb{Z}^2|.$$

More details on this can be found in [CLS11, section 10.5].

## 2.2 Floor diagrams and tropical refined invariants

Brugallé and Mikhalkin have introduced in [BM07, BM08] some objects called *floor diagrams*. This combinatorial tool allows to count tropical curves, and so to count curves on toric surfaces. In this section we recall how to define floor diagrams. We then state two theorems that relate floors diagrams to enumerative questions, and which will be the definitions of refined invariants for us. Last, we prove some properties on floor diagrams that will be useful throughout this text.

### 2.2.1 $h$ -transverse polygons and floor diagrams

We introduce first some definitions and notations regarding polygons. Up to notational details, it is mainly borrowed from [BJP22, section 2].

**Definition 2.2.1.** *Let  $\Delta$  be a polygon. We said that  $\Delta$  is :*

- ▷  *$h$ -transverse if any of its edge has an outward normal vector of the form  $(0, \pm 1)$  or  $(\pm 1, n)$  for some  $n \in \mathbb{Z}$ ,*
- ▷ *horizontal if it has a top and bottom horizontal edge.*

*If  $\mathcal{F}$  is a fan, then by definition  $\mathcal{F}$  is  $h$ -transverse (resp. horizontal) if any dual polygon  $\Delta \in D(\mathcal{F})$  is.*

*Remark 2.2.2.* Note that a fan  $\mathcal{F}$  is  $h$ -transverse (resp. horizontal) if and only if there exists a polygon  $\Delta \in D(\mathcal{F})$  which is  $h$ -transverse (resp. horizontal). As noticed in section 2.1.2, the same holds for “non-singular”.

A polygon  $\Delta$  has some combinatorial data that is related to the enumerative problems we are interested in throughout this text. We set the following notations, and we will drop  $\Delta$  when no ambiguity is possible :

- ▷  $a(\Delta)$  is the height of  $\Delta$ , i.e. the difference between the maximal and the minimal ordinate of a point of  $\Delta$ ,
- ▷  $e^{+\infty}(\Delta)$  (resp.  $e^{-\infty}(\Delta)$ ) is the length of the top (resp. bottom) horizontal edge of  $\Delta$  (these may be 0 if  $\Delta$  is not horizontal) and  $e^\infty(\Delta) = e^{+\infty}(\Delta) + e^{-\infty}(\Delta)$ ,
- ▷  $y(\Delta) = |\partial\Delta \cap \mathbb{Z}^2|$  the number of integer points on the boundary of  $\Delta$ , by section 2.1.3 it is equal to  $-\mathcal{L}_\Delta \cdot K_{X_\Delta}$ ,
- ▷  $\chi(\Delta)$  is the number of vertices of  $\Delta$ , by section 2.1.3 it is the Euler characteristic of  $X_\Delta$ ,
- ▷  $g_{\max}(\Delta) = |\mathring{\Delta} \cap \mathbb{Z}^2|$  the number of interior lattice points of  $\Delta$ , by section 2.1.3 it is the maximal genus of a curve in the linear system associated to  $\mathcal{L}_\Delta$  if  $X_\Delta$  is non-singular,
- ▷  $s_{\max}(\Delta, g) = \left\lfloor \frac{y(\Delta) - 1 + g}{2} \right\rfloor$  for  $g \in \mathbb{N}$ .

Note that if  $\Delta$  is  $h$ -transverse then  $y(\Delta) = e^\infty(\Delta) + 2a(\Delta)$ . Moreover, in that case we denote :

- ▷  $b_{\text{left}}(\Delta)$  (resp.  $b_{\text{right}}(\Delta)$ ) the unordered list of integers  $k$  appearing  $j$  times, where  $j$  is the integral length of the side of  $\Delta$  having  $(-1, k)$  (resp.  $(1, k)$ ) as outward normal vector.

*Example 2.2.3.* Consider the polygons of figure 2.4. The polygons  $\Delta_a$  and  $\Delta_b$  are  $h$ -transverse but  $\Delta_c$  is not, only  $\Delta_b$  is horizontal and only  $\Delta_a$  is non-singular. We give in table 2.1 their combinatorial data.

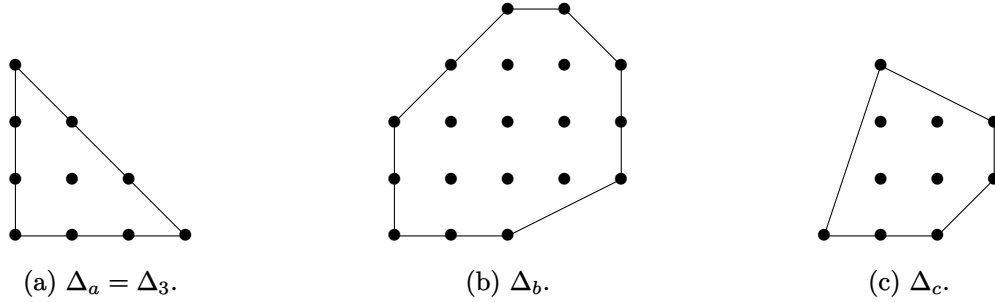

Figure 2.4 – Some polygons.

	$a(\Delta)$	$e^{+\infty}(\Delta)$	$e^{-\infty}(\Delta)$	$y(\Delta)$	$\chi(\Delta)$	$g_{\max}(\Delta)$	$b_{\text{left}}(\Delta)$	$b_{\text{right}}(\Delta)$
$\Delta_a$	3	0	3	9	3	1	{0, 0, 0}	{1, 1, 1}
$\Delta_b$	4	1	2	11	7	8	{0, 0, 1, 1}	{-2, 0, 0, 1}
$\Delta_c$	3	0	2	6	5	4	/	/

Table 2.1 – Combinatorial data of the polygons of figure 2.4.

We now introduce some terminology on graphs. An *oriented graph*  $\Gamma$  is a collection of vertices  $V(\Gamma)$ , of bounded edges  $E^0(\Gamma)$  (i.e. of oriented edges adjacent to two vertices), and of infinite edges  $E^\infty(\Gamma)$  (i.e. of oriented edges adjacent to one vertex). An infinite edge oriented toward (resp. from) its adjacent vertex is called a *source* (resp. a *sink*), and we denote by  $E^{-\infty}(\Delta)$  the set of sources (resp. by  $E^{+\infty}(\Gamma)$  the set of sinks). We denote by  $E(\Gamma)$  the set of all edges of  $\Gamma$ . The graph  $\Gamma$  is *weighted* if there is a function  $w : E(\Gamma) \rightarrow \mathbb{N}^*$ . Given a vertex  $v \in V(\Gamma)$  of an oriented weighted graph, the *divergence*  $\text{div}(v)$  is the difference of the weights entering and leaving  $v$ , i.e.

$$\text{div}(v) = \sum_{e \xrightarrow{v}} w(e) - \sum_{v \xrightarrow{e}} w(e).$$

Last, the *genus* of a graph  $\Gamma$  is its first Betti number.

**Definition 2.2.4 (Floor diagram).** *Let  $\Delta$  be an  $h$ -transverse polygon and  $g \in \mathbb{N}$ . A floor diagram  $\mathcal{D}$  with Newton polygon  $\Delta$  and genus  $g$  is a quadruple  $(\Gamma, w, L, R)$  such that*

- ▷  $(\Gamma, w)$  is a weighted, connected, oriented and acyclic graph of genus  $g$ ,
- ▷ the graph  $\Gamma$  has  $a(\Delta)$  vertices,  $e^{+\infty}(\Delta)$  sinks and  $e^{-\infty}(\Delta)$  sources,
- ▷ all the infinite edges have weight 1,
- ▷  $L : V(\Gamma) \rightarrow b_{\text{left}}(\Delta)$  and  $R : V(\Gamma) \rightarrow b_{\text{right}}(\Delta)$  are bijections such that for every vertex  $v \in V(\Gamma)$  one has  $\text{div}(v) = L(v) + R(v)$ .

By abuse of notations, we will use  $\mathcal{D}$  for  $\Gamma$ . If  $\mathcal{D}$  is a floor diagram its number of elements  $n(\mathcal{D})$  is its number of vertices and edges, i.e.

$$n(\mathcal{D}) = |V(\mathcal{D})| + |E(\mathcal{D})|.$$

Since one has  $|E(\mathcal{D})| = |E^0(\mathcal{D})| + |E^\infty(\mathcal{D})|$ ,  $|V(\mathcal{D})| - |E^0(\mathcal{D})| = 1 - g$  with  $g$  the genus of  $\mathcal{D}$ , and  $|V(\mathcal{D})| = a(\Delta)$  with  $\Delta$  the Newton polygon of  $\mathcal{D}$ , then

$$n(\mathcal{D}) = y(\Delta) - 1 + g.$$

The *degree* and *codegree* of a diagram  $\mathcal{D}$  with Newton polygon  $\Delta$  and genus  $g$  are

$$\text{deg}(\mathcal{D}) = \sum_{e \in E(\mathcal{D})} (w(e) - 1) \quad \text{and} \quad \text{codeg}(\mathcal{D}) = g_{\max}(\Delta) - g - \text{deg}(\mathcal{D}).$$

*Remark 2.2.5.* The codegree is always non-negative ; we will prove it later, see proposition 2.2.24.

We will always draw the floor diagrams oriented from bottom to top. Hence we do not put any arrow on the edges to show the orientation. Moreover we indicate the weights of the edges only if their are at least 2. We give some examples of floor diagrams.

*Example 2.2.6.* Figure 2.5 gives all the floor diagrams with Newton polygon  $\Delta_3$ , see figure 2.4a. Here, the functions  $R$  and  $L$  are constant equal to 1 and 0, so any vertex has divergence 1.

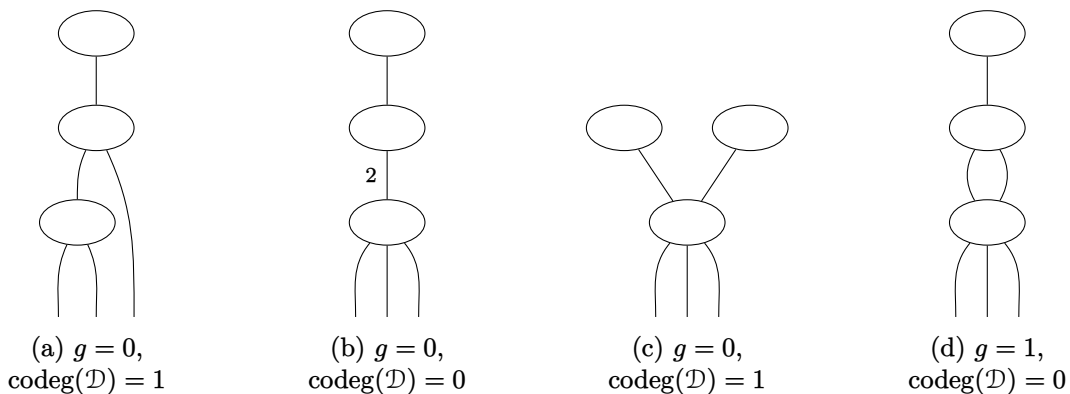

Figure 2.5 – The floor diagrams with Newton polygon  $\Delta_3$ .

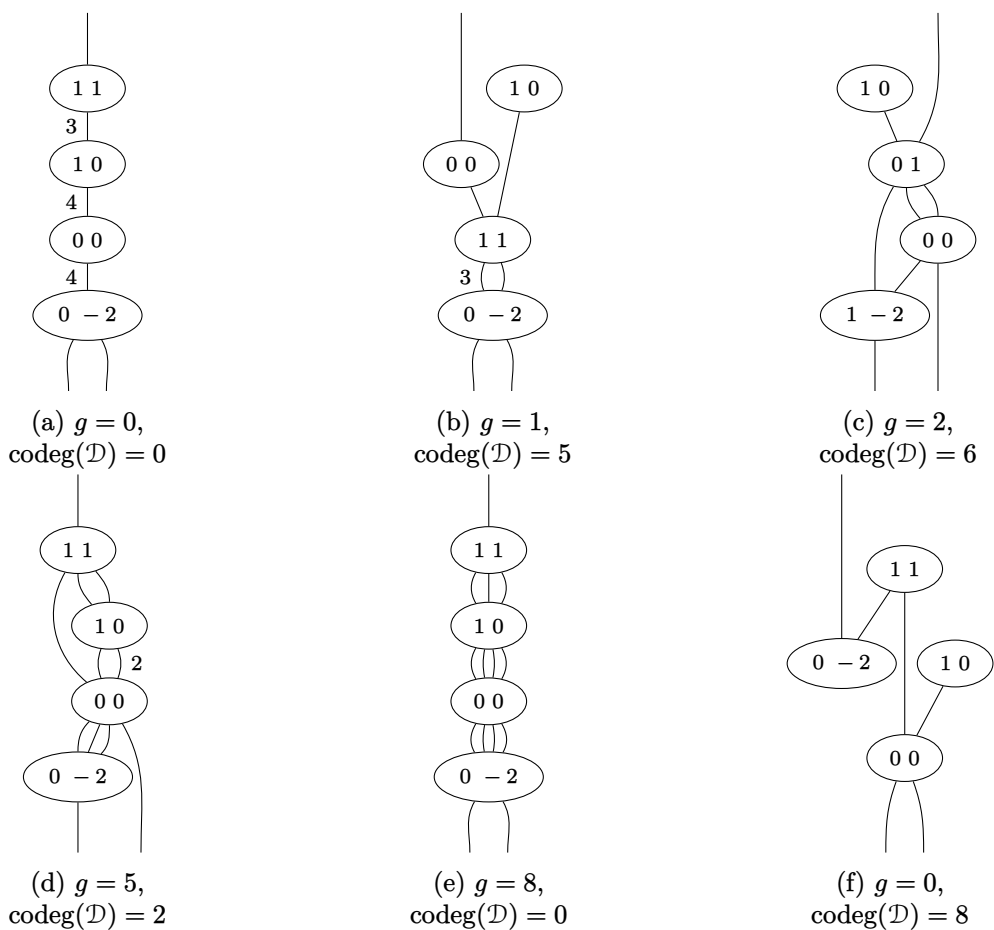

Figure 2.6 – Some floor diagrams with Newton polygon the polygon of figure 2.4b.

*Example 2.2.7.* Figure 2.6 gives some floor diagrams with Newton polygon the polygon of figure 2.4b. We show in each vertex the values of  $R$  and  $L$ ,

### 2.2.2 Refined invariants

We now introduce the necessary notions to relate floor diagrams to enumerative questions, and define refined invariants. A *Laurent polynomial* with integer coefficients is an element of  $\mathbb{Z}[[q]]$ . If a Laurent polynomial is symmetric, its *degree* is the maximum of the exponents appearing with a non-zero coefficient. If a Laurent polynomial  $P$  has degree  $d$ , we denote by  $\langle P \rangle_i$  its *codegree  $i$*  coefficient, i.e. the coefficient of its term of degree  $d - i$ .

#### Block-Göttsche invariants

The orientation of a floor diagram  $\mathcal{D}$  induces a partial order  $\prec$  on the set of its elements  $E(\mathcal{D}) \cup V(\mathcal{D})$ . More precisely, given two elements  $\alpha$  and  $\beta$  we write  $\alpha \prec \beta$  if there exists an oriented path in  $\mathcal{D}$  from  $\alpha$  to  $\beta$ . Hence, one can define increasing functions on a floor diagram.

**Definition 2.2.8 (Marking).** *Let  $\mathcal{D}$  be a floor diagram with Newton polygon  $\Delta$ . A marking of  $\mathcal{D}$  is an increasing bijection*

$$m : E(\mathcal{D}) \cup V(\mathcal{D}) \rightarrow \{1, \dots, n(\mathcal{D})\}$$

The couple  $(\mathcal{D}, m)$  is called a marked floor diagram.

Two marked floor diagrams  $(\mathcal{D}, m)$  and  $(\mathcal{D}', m')$  with Newton polygon  $\Delta$  and genus  $g$  are isomorphic if there exists an isomorphism  $\varphi : \mathcal{D} \rightarrow \mathcal{D}'$  of weighted graphs such that  $L = L' \circ \varphi$ ,  $R = R' \circ \varphi$  and  $m = m' \circ \varphi$ . We denote by  $\nu(\mathcal{D})$  the number of markings of a diagram  $\mathcal{D}$  up to isomorphisms.

*Example 2.2.9.* Figure 2.7 gives examples of markings of the floor diagram of figure 2.5a. The marked floor diagrams of figures 2.7a and 2.7b are isomorphic.

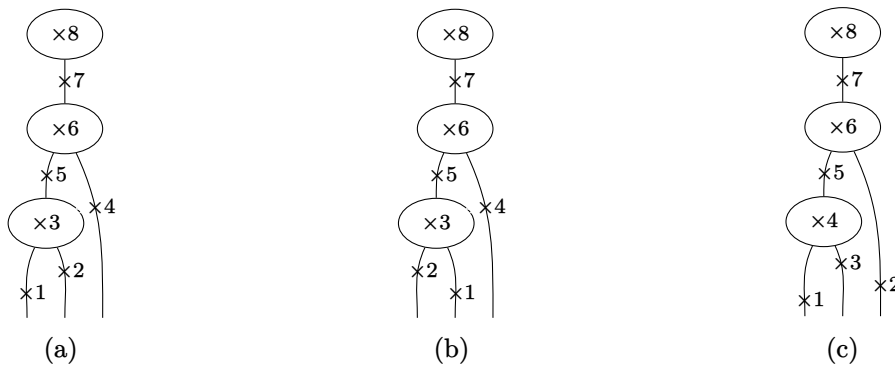

Figure 2.7 – Some marked floor diagrams.

For  $n \in \mathbb{Z}$  the quantum integer  $[n](q)$  is defined by

$$[n](q) = \frac{q^{n/2} - q^{-n/2}}{q^{1/2} - q^{-1/2}} = q^{(n-1)/2} + q^{(n-3)/2} + \dots + q^{-(n-3)/2} + q^{-(n-1)/2} \in \mathbb{N}[q^{\pm 1/2}].$$

We will use the shortcuts

$$[n]^2 = [n](q)^2 \text{ and } [n]_2 = [n](q^2).$$

**Definition 2.2.10 (Block-Göttsche multiplicity).** *The Block-Göttsche multiplicity of a marked floor diagram  $(\mathcal{D}, m)$  is*

$$\mu_{\text{BG}}(\mathcal{D}, m)(q) = \prod_{e \in E(\mathcal{D})} [w(e)]^2 \in \mathbb{Z}[q^{\pm 1/2}].$$

*It is a Laurent polynomial of degree  $\deg(\mathcal{D})$ .*

**Theorem 2.2.11 ([BG16a, Theorem 4.3]).** *Let  $\Delta$  be an  $h$ -transverse polygon and  $g \in \mathbb{N}$ . The tropical refined invariant is given by*

$$G_g(\Delta) = \sum_{(\mathcal{D}, m)} \mu_{\text{BG}}(\mathcal{D}, m) \in \mathbb{Z}[q^{\pm 1}]$$

*where the sums runs over the isomorphism classes of marked floor diagrams with Newton polygon  $\Delta$  and genus  $g$ .*

*Remark 2.2.12.* By proposition 2.2.24, the degree of the tropical refined invariant  $G_g(\Delta)$  is at most  $g_{\max}(\Delta) - g$ . By the same proposition, there exists floor diagrams with Newton polygon  $\Delta$ , genus  $g$  and degree  $g_{\max}(\Delta) - g$ . Because for any marked diagram  $\mathcal{D}$  the leading coefficient of  $\mu_{\text{BG}}(\mathcal{D}, m)$  is 1, we conclude that  $\deg(G_g(\Delta)) = g_{\max}(\Delta) - g$ .

*Remark 2.2.13.* In this text we will be interested in the codegree  $i$  coefficient of  $G_g(\Delta)$ , denoted by  $\langle G_g(\Delta) \rangle_i$ . One has

$$\langle G_g(\Delta) \rangle_i = \sum_{(\mathcal{D}, m)} \langle \mu_{\text{BG}}(\mathcal{D}, m) \rangle_{i - \text{codeg}(\mathcal{D})}$$

where the sum is over the isomorphism classes of marked floor diagrams with Newton polygon  $\Delta$ , genus  $g$ , and codegree at most  $i$ .

*Example 2.2.14.* Let  $\mathcal{D}_1$ ,  $\mathcal{D}_2$  and  $\mathcal{D}_3$  be the diagrams of figures 2.5a, 2.5b and 2.5c. Let  $m_k$  be any marking of  $\mathcal{D}_k$ . One has  $\mu_{\text{BG}}(\mathcal{D}_1, m_1) = \mu_{\text{BG}}(\mathcal{D}_3, m_3) = 1$  and  $\mu_{\text{BG}}(\mathcal{D}_2, m_2) = q + 2 + q^{-1}$ , and the numbers of markings are  $\nu(\mathcal{D}_1) = 5$ ,  $\nu(\mathcal{D}_2) = 1$  and  $\nu(\mathcal{D}_3) = 3$ . Hence one has  $G_0(\Delta_3) = q + 10 + q^{-1}$ .

### Göttsche-Schroeter invariants

Block-Göttsche invariants admit an extension in genus 0, called Göttsche-Schroeter invariants and denoted  $G_0(\Delta, s)$ , with a new variable  $s$ . We now explain how to calculate Göttsche-Schroeter invariants using floor diagrams.

A *pairing of order  $s$*  of the set  $\{1, \dots, n\}$  is a set  $S$  of  $s$  disjoint pairs  $\{i, i+1\} \subset \{1, \dots, n\}$ . Given a floor diagram  $\mathcal{D}$  and a pairing  $S$  of  $\{1, \dots, n(\mathcal{D})\}$ , we say that a marking  $m$  is *compatible* with  $S$  if for any  $\alpha \in S$ , the set  $m^{-1}(\alpha)$  consists of

- ▷ either an edge and an adjacent vertex,
- ▷ or two edges that are both entering or both leaving the same vertex.

Let  $(\mathcal{D}, m)$  be a marked floor diagram and  $S$  a pairing compatible with  $m$ . We define

$$\begin{aligned} E_0 &= \{e \in E(\mathcal{D}) \mid \forall \alpha \in S, e \notin m^{-1}(\alpha)\}, \\ E_1 &= \{e \in E(\mathcal{D}) \mid \exists v \in V(\mathcal{D}), \exists \alpha \in S, \{e, v\} = m^{-1}(\alpha)\}, \\ E_2 &= \{\{e, e'\} \subset E(\mathcal{D}) \mid \exists \alpha \in S, \{e, e'\} = m^{-1}(\alpha)\}. \end{aligned}$$

**Definition 2.2.15 (Refined  $S$ -multiplicity).** *The refined  $S$ -multiplicity of a marked floor diagram  $(\mathcal{D}, m)$  is*

$$\mu_S(\mathcal{D}, m)(q) = \prod_{e \in E_0} [w(e)]^2 \prod_{e \in E_1} [w(e)]_2 \prod_{\{e, e'\} \in E_2} \frac{[w(e)][w(e')][w(e) + w(e')]}{[2]} \in \mathbb{Z}[q^{\pm 1/2}]$$

if  $S$  and  $m$  are compatible, and  $\mu_S(\mathcal{D}, m)(q) = 0$  otherwise. If non-zero, it is a Laurent polynomial of degree  $\deg(\mathcal{D})$ .

The following theorem can be taken as a definition of the Göttsche-Schroeter invariants.

**Theorem 2.2.16 ([BJP22, theorem 2.13]).** *Let  $\Delta$  be an  $h$ -transverse polygon and  $s \in \{0, \dots, s_{\max}(\Delta, 0)\}$ . For any pairing  $S$  of order  $s$  of  $\{1, \dots, y(\Delta) - 1\}$  one has*

$$G_0(\Delta, s) = \sum_{(\mathcal{D}, m)} \mu_S(\mathcal{D}, m)$$

where the sum runs over the isomorphism classes of marked floor diagrams with Newton polygon  $\Delta$  and genus 0.

*Remark 2.2.17.* Let  $\mathcal{D}$  be a diagram of Newton polygon  $\Delta$  and codegree 0 (see proposition 2.2.24). Then any pairing  $S$  is compatible with any marking  $m$  of  $\mathcal{D}$ , i.e.  $\mu_S(\mathcal{D}, m) \neq 0$ . We deduce that  $\deg(G_0(\Delta, s)) = g_{\max}(\Delta)$ .

*Remark 2.2.18.* In this text we will be interested in the codegree  $i$  coefficient of  $G_0(\Delta, s)$ , denoted  $\langle G_0(\Delta, s) \rangle_i$ . One has

$$\langle G_0(\Delta, s) \rangle_i = \sum_{(\mathcal{D}, m)} \langle \mu_S(\mathcal{D}, m) \rangle_{i - \text{codeg}(\mathcal{D})}$$

where the sum is over the isomorphisms classes of marked floor diagrams with Newton polygon  $\Delta$ , genus 0 and codegree at most  $i$ .

*Remark 2.2.19.* The theorem implies that the right-hand side does not depend on the pairing  $S$  as long as it has order  $s$ . Thus, to study  $G_0(\Delta, s)$  we can choose a particular pairing which makes the calculations easier.

Chapter 3 is mainly devoted to prove that we can define an analogous combinatorial quantity for any genus, see theorem 3.1.3. More precisely, we will give a combinatorial proof that, in any genus  $g$ , the sum of the right hand side of theorem 2.2.16 does not depend on  $S$ , leading to a quantity we will denote  $G_g(\Delta, s)$ .

*Example 2.2.20.* If  $s = 0$  then  $S = \emptyset$  and  $\mu_S(\mathcal{D}, m) = \mu_{\text{BG}}(\mathcal{D}, m)$ . Hence  $G_0(\Delta, 0) = G_0(\Delta)$ .

*Example 2.2.21.* We continue example 2.2.14. Let  $\mathcal{D}_1, \mathcal{D}_2$  and  $\mathcal{D}_3$  be the floor diagrams of figures 2.5a, 2.5b and 2.5c. The following table 2.2 gives their contributions to the refined invariant, using the pairing  $S = \{\{1, 2\}, \dots, \{2s-1, 2s\}\}$  of order  $s$ . Hence one has  $G_0(\Delta_3, s) = q + (10 - 2s) + q^{-1}$ .

	$s = 0$	$s = 1$	$s = 2$	$s = 3$	$s = 4$
$\mathcal{D}_1$	5	3	1	1	1
$\mathcal{D}_2$	$q + 2 + q^{-1}$	$q + 2 + q^{-1}$	$q + 2 + q^{-1}$	$q + q^{-1}$	$q + q^{-1}$
$\mathcal{D}_3$	3	3	3	3	1
$G_0(\Delta_3, s)$	$q + 10 + q^{-1}$	$q + 8 + q^{-1}$	$q + 6 + q^{-1}$	$q + 4 + q^{-1}$	$q + 2 + q^{-1}$

Table 2.2 – Computation of  $G_0(\Delta_3, s)$ .

*Remark 2.2.22.* A *lattice preserving transformation* is a map  $f : \mathbb{R}^2 \rightarrow \mathbb{R}^2$  obtained as a composition of

- ▷ isomorphisms of  $\mathbb{R}^2$  induced by elements of  $\text{GL}_2(\mathbb{Z})$ ,
- ▷ translations that preserves the lattice  $\mathbb{Z}^2$ , i.e. translations by a vector  $u \in \mathbb{Z}^2$ .

In other words, a lattice preserving transformation is an element of the affine group of  $\mathbb{R}^2$  for which the lattice  $\mathbb{Z}^2$  is invariant. We say that  $\Delta$  and  $\Delta'$  are *congruent* if there exists a lattice preserving transformation  $f$  such that  $\Delta' = f(\Delta)$ . If  $\Delta$  and  $\Delta'$  are congruent, then  $G_0(\Delta, s) = G_0(\Delta', s)$ . Indeed, a translation does not change the family of floor diagrams defined by  $\Delta$ . Moreover, a floor diagram is a way to encode a tropical curve  $C$ . Via the dual subdivision



of  $\Delta$  corresponding to  $C$ , a matrix of  $\text{GL}_2(\mathbb{Z})$  which acts on  $\Delta$  also acts on  $C$ , and preserves its multiplicity. Hence the total count does not change.

### 2.2.3 Few lemmas on floor diagrams

In this section we prove some properties on floors diagrams. By remarks 2.2.13 and 2.2.18 we will look at floor diagrams of codegree at most  $i$ . Most of the following lemmas deal with properties of these diagrams. We determine some conditions which constrain the floor diagrams to have a total order on the set of their vertices, and to have large weights on their bounded edges. Before that, we begin this part by describing some operations that transform one floor diagram into another.

#### Operations on floor diagrams

We will use the following operations on floor diagrams to prove the lemmas of this section.

$A^+$  : If there are vertices  $v_1 \prec v_2$  connected by an edge  $e_1$  and another edge  $e_2$  leaving  $v_1$  but not entering  $v_2$ , then we construct a new diagram as depicted in figure 2.8a.

$A^-$  : Similarly if  $e_2$  is entering  $v_2$  but not leaving  $v_1$ , see figure 2.8b.

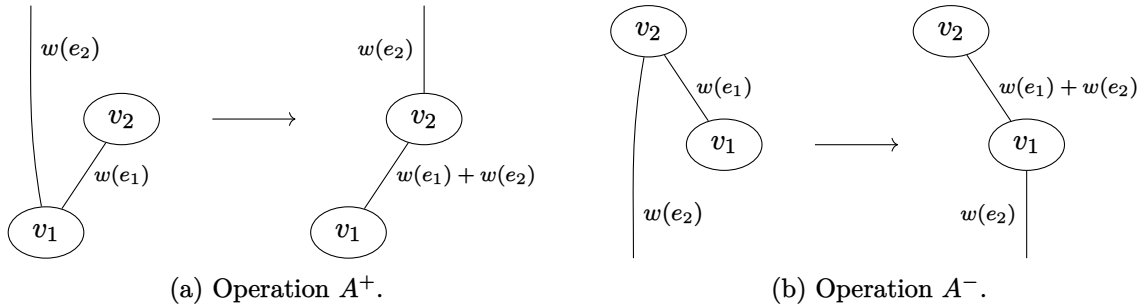

Figure 2.8 – Operations  $A^+$  and  $A^-$ .

$B^L$  : If there are vertices  $v_1 \prec v_2$  connected by an edge  $e$  and such that  $L(v_1) > L(v_2)$ , then we construct a new diagram as depicted in figure 2.9a.

$B^R$  : Similarly if  $R(v_1) > R(v_2)$ , see figure 2.9b.

**Lemma 2.2.23 ([BJP22, lemma 3.2]).** *Genus and Newton polygon are invariant under operations  $A^\pm$  and  $B^{L,R}$ . Furthermore, the codegree decreases by  $w(e_2)$  under operations  $A^\pm$ , by  $L(v_1) - L(v_2)$  under operation  $B^L$  and by  $R(v_1) - R(v_2)$  under operation  $B^R$ .*

We can now prove that the codegree of a floor diagram is non-negative, see remark 2.2.5. We also give a description of floor diagrams of codegree 0.

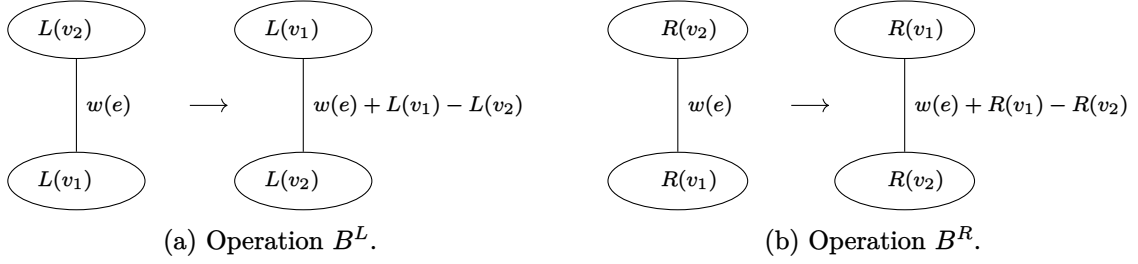
 Figure 2.9 – Operations  $B^L$  and  $B^R$ .

**Proposition 2.2.24.** *Let  $\Delta$  be an  $h$ -transverse polygon and  $g \in \mathbb{N}$ . For any floor diagram  $\mathcal{D}$  of Newton polygon  $\Delta$  and genus  $g$ , one has  $\deg(\mathcal{D}) \leq g_{\max}(\Delta) - g$ , i.e.  $\text{codeg}(\mathcal{D}) \geq 0$ . Moreover,  $\text{codeg}(\mathcal{D}) = 0$  if and only if :*

- ▷ the order is total on the set of vertices of  $\mathcal{D}$ ,
- ▷ the functions  $R$  and  $L$  are increasing,
- ▷ any bounded edge is adjacent to two consecutive vertices,
- ▷ any source (resp. sink) is adjacent to the minimal (resp. maximal) vertex.

*In particular, there exists a floor diagram of Newton polygon  $\Delta$ , genus  $g$  and codegree 0. If  $g = 0$ , such a floor diagram is unique.*

*Proof.* Let  $\mathcal{D}$  be a floor diagram of Newton polygon  $\Delta$  and genus  $g$ , and assume that  $\mathcal{D}$  has maximal degree among those floor diagrams.

Assume that the order is not total on the vertices of  $\mathcal{D}$ , i.e. it has two maximal or two minimal vertices. By symmetry we only deal with the case where  $\mathcal{D}$  has two maximal vertices. By a finite number of operations  $A^+$  we can turn  $\mathcal{D}$  into the diagram  $\mathcal{D}'$  depicted in figure 2.10a, where  $w_k$  is the total weight of the edges between  $v_0$  and  $v_k$ , for  $k = 1, 2$ . Performing more operations  $A^+$  we get the diagram  $\mathcal{D}''$  of figure 2.10b. By lemma 2.2.23, the diagram  $\mathcal{D}''$  has Newton polygon  $\Delta$  and genus  $g$ , and  $\text{codeg}(\mathcal{D}'') < \text{codeg}(\mathcal{D})$  i.e.  $\deg(\mathcal{D}'') > \deg(\mathcal{D})$ , which contradicts the choice of  $\mathcal{D}$ . Hence the order is total on the vertices of  $\mathcal{D}$ . Let  $v_1 \prec \dots \prec v_a$  be the vertices.

If the function  $R$  (resp.  $L$ ) is not increasing, then with an operation  $B^R$  (resp.  $B^L$ ) we construct another floor diagram with degree greater than the one of  $\mathcal{D}$  by lemma 2.2.23, which is a contradiction. Hence the functions  $R$  and  $L$  are increasing.

Assume  $\mathcal{D}$  has a bounded edge adjacent to two non-consecutive vertices, or an infinite edge adjacent to a non-extremal vertex. Then by an operation  $A^\pm$  we construct another floor diagram with degree greater than the one of  $\mathcal{D}$  by lemma 2.2.23, which is a contradiction. Hence any bounded edge is adjacent to two consecutive vertices, and any infinite edge is adjacent to an

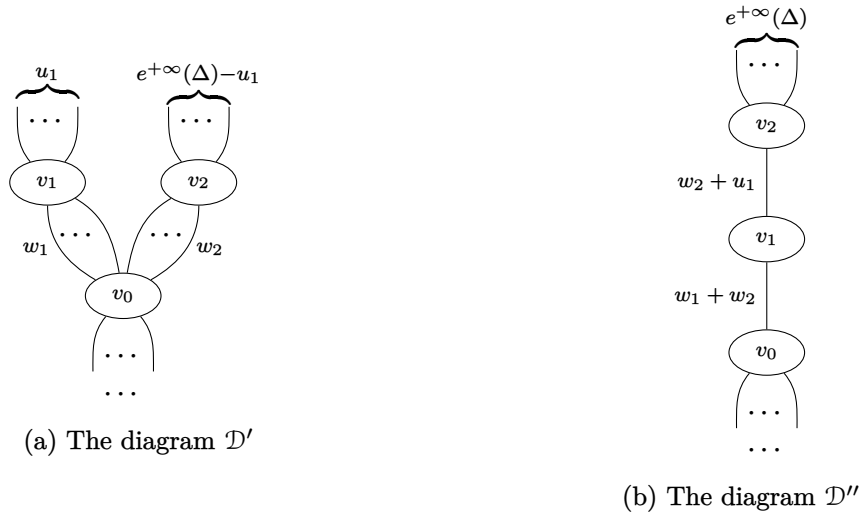

Figure 2.10 – Diagram with two maximal vertices.

extremal vertex. If a source (resp. a sink) is adjacent to the maximal (resp. minimal) vertex, we similarly obtain a contradiction. Hence, the diagram  $\mathcal{D}$  looks like the diagram of figure 2.11.

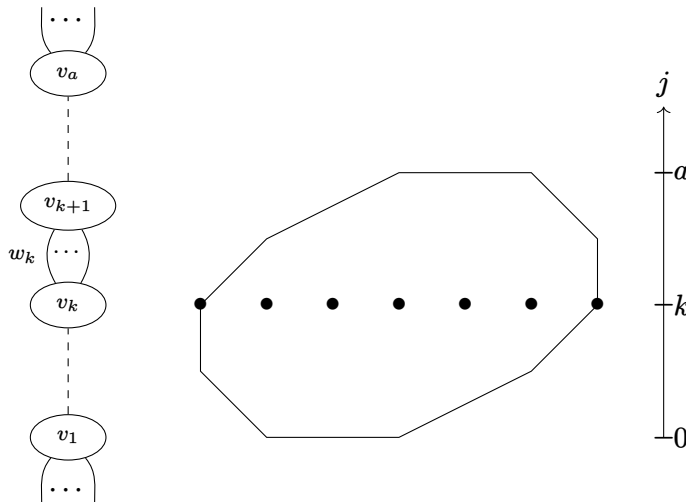

Figure 2.11 – A floor diagram of genus  $g$  with maximal degree, and its Newton polygon  $\Delta$ .

Let  $g_k + 1$  be the number of edges between the vertices  $v_k$  and  $v_{k+1}$ . Because  $\mathcal{D}$  has genus  $g$ , one has  $g_1 + \dots + g_{a-1} = g$ . Let  $w_k$  be the sum of the weights of the edges between  $v_k$  and  $v_{k+1}$ . These edges contribute  $w_k - g_k - 1$  to  $\deg(\mathcal{D})$ . Moreover, because  $R$  and  $L$  are increasing then one has

$$w_k = e^{+\infty}(\Delta) + \sum_{n=k+1}^a (R(v_n) + L(v_n)) = |\mathring{\Delta} \cap \{j = k\} \cap \mathbb{Z}^2| + 1,$$

see figure 2.11, and thus

$$\deg(\mathcal{D}) = \sum_{k=1}^{a-1} (w_k - g_k - 1) = |\dot{\Delta} \cap \mathbb{Z}^2| - g = g_{\max}(\Delta) - g.$$

Hence the maximal degree for a floor diagram of Newton polygon  $\Delta$  and genus  $g$  is  $g_{\max}(\Delta) - g$ , and the minimal codegree is then 0, which shows the proposition.  $\square$

### Properties of diagrams of bounded codegree

We start with an auxiliary lemma that gives a bound on the divergence of a diagram.

**Lemma 2.2.25.** *Given an  $h$ -transverse fan  $\mathcal{F}$ , there exists  $d_{\mathcal{F}} \in \mathbb{N}$  such that for any floor diagram with Newton polygon  $\Delta \in D(\mathcal{F})$  one has  $|\text{div}| \leq d_{\mathcal{F}}$ .*

*Proof.* By hypothesis, the rays of  $\mathcal{F}$  are defined by vectors of the form  $\pm(0, 1)$  or  $\pm(1, k)$  for some  $k \in \mathbb{Z}$ . Let  $N_R$  (resp.  $n_R$ ) be the the maximal (resp. minimal) integer  $k$  such that  $(1, k)$  is a primitive vector of a ray of  $\mathcal{F}$ . Then the function  $R$  of any floor diagram is bounded :

$$n_R \leq R \leq N_R.$$

Similarly, let  $N_L$  (resp.  $n_L$ ) be the the maximal (resp. minimal) integer  $k$  such that  $(-1, k)$  is a primitive vector of a ray of  $\mathcal{F}$ . Then the function  $L$  of any floor diagram is bounded :

$$n_L \leq L \leq N_L.$$

Since  $\text{div} = R + L$  one has

$$n_R + n_L \leq \text{div} \leq N_R + N_L$$

and the result holds for  $d_{\mathcal{F}} = \max(|N_R + N_L|, |n_R + n_L|)$ .  $\square$

We now prove of bunch of lemmas regarding diagrams of bounded codegree. They are all in the same flavour, but slightly different hypothesis lead to slightly different applications and conclusions. In particular, lemma 2.2.30 gives better bounds than the others, but it does not apply for non-horizontal Newton polygons.

The following lemma is proven in particular cases but with sharper bounds in [BJP22, lemmas 4.1 and 5.5].

**Lemma 2.2.26.** *Let  $\Delta$  be an  $h$ -transverse polygon with dual fan  $\mathcal{F}$ .*

- (1) *If  $e^{+\infty}(\Delta) > i + d_{\mathcal{F}}$  then any floor diagram with Newton polygon  $\Delta$  and codegree at most  $i$  has a unique maximal floor.*

(2) If  $e^{-\infty}(\Delta) > i + d_{\mathcal{F}}$  then any floor diagram with Newton polygon  $\Delta$  and codegree at most  $i$  has a unique minimal floor.

(3) If  $e^{+\infty}(\Delta) > i + d_{\mathcal{F}}$  and  $e^{-\infty}(\Delta) > i + d_{\mathcal{F}}$  then any floor diagram with Newton polygon  $\Delta$ , genus 0, and codegree at most  $i$  admits a total order on its set of vertices.

*Remark 2.2.27.* Note that contrary to (1) and (2), the assertion (3) is not true if the genus is non-zero.

*Proof.* The item (3) is an immediate consequence of (1) and (2), and to prove (2) it suffices to apply (1) to  $-\Delta$ . Hence we prove (1).

Let  $\mathcal{D}$  be a floor diagram with Newton polygon  $\Delta$ . Assume that  $\mathcal{D}$  admits two maximal vertices. By a finite number of operations  $A^+$  we can turn  $\mathcal{D}$  into the diagram  $\mathcal{D}'$  depicted in figure 2.10a. Performing more operations  $A^+$  we get the diagram  $\mathcal{D}''$  of figure 2.10b. By lemma 2.2.23 the codegree decreases by  $w_2 + u_1$  under these operations. But  $w_2 = e^{+\infty}(\Delta) - u_1 + \text{div}(v_2)$  hence the codegree decreases by  $e^{+\infty}(\Delta) + \text{div}(v_2)$  and

$$\text{codeg}(\mathcal{D}) \geq \text{codeg}(\mathcal{D}'') + e^{+\infty}(\Delta) + \text{div}(v_2) > i.$$

□

**Lemma 2.2.28.** *Let  $\mathcal{D}$  be a floor diagram of codegree at most  $i$ , and  $a = |V(\mathcal{D})|$ . If  $\mathcal{D}$  has a unique maximal (resp. minimal) floor then the order is total on the  $a - i - 1$  highest (resp. lowest) floors.*

*In particular, if  $a \geq 2(i + 2)$  and if  $\mathcal{D}$  has a unique maximal and minimal vertex, then the order is total on the vertices of  $\mathcal{D}$ .*

*Proof.* We will give the proof in the case where  $\mathcal{D}$  has a unique top floor, the other point being proved applying that case to  $-\Delta$ .

Let  $b$  be the maximal integer such that the order is total on  $v_{a-b} \prec \dots \prec v_a$ . We would like to show that  $a - b \leq i + 2$ . Assume the contrary. By operations  $A^{\pm}$  we reduce to the case where  $\mathcal{D}$  looks like the diagram of figure 2.12. By more operations  $A^-$  we can attach  $v_c$  under  $v_{c+2}$  which reduces the codegree by at least  $a - b - c - 2$ . Then we attach  $v_{c+1}$  under  $v_1$  by other operations  $A^-$  which reduces the codegree by at least  $c$ . Hence we have

$$\text{codeg}(\mathcal{D}) \geq (a - b - c - 2) + c = a - b - 2 > i$$

which is a contradiction. □

The following lemma is a generalization of the last assertion of [BJP22, lemma 4.1]. It is specific to the genus 0 case.

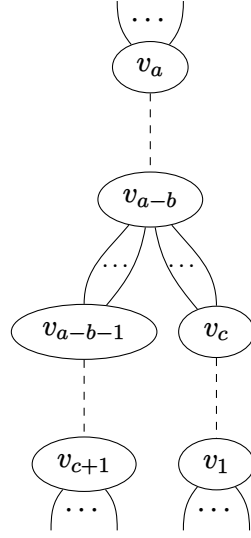

Figure 2.12 – A diagram with a unique maximal floor.

**Lemma 2.2.29.** *Let  $i \in \mathbb{N}$  and  $\Delta$  be an  $h$ -transverse polygon with dual fan  $\mathcal{F}$ . Let  $(a, e^{+\infty}, e^{-\infty}) = (a(\Delta), e^{+\infty}(\Delta), e^{-\infty}(\Delta))$  and assume  $a > 2(i + 2)$ .*

- (1) *If  $e^{+\infty} > i + (a - \lfloor a/2 \rfloor + 1)d_{\mathcal{F}}$ , then the weights of the  $a - \lfloor a/2 \rfloor$  highest bounded edges of any floor diagram with Newton polygon  $\Delta$ , genus 0 and codegree at most  $i$  are greater than  $i - \text{codeg}(\mathcal{D})$ .*
- (2) *If  $e^{-\infty} > i + (a - \lfloor a/2 \rfloor + 1)d_{\mathcal{F}}$ , then the weights of the  $a - \lfloor a/2 \rfloor$  lowest bounded edges of any floor diagram with Newton polygon  $\Delta$ , genus 0 and codegree at most  $i$  are greater than  $i - \text{codeg}(\mathcal{D})$ .*
- (3) *If  $e^{\pm\infty} > i + (a - \lfloor a/2 \rfloor + 1)d_{\mathcal{F}}$ , then the weights of all the bounded edges of any floor diagram with Newton polygon  $\Delta$ , genus 0 and codegree at most  $i$  are greater than  $i - \text{codeg}(\mathcal{D})$ .*

*Proof.* The item (3) is an immediate consequence of (1) and (2), and to prove (2) it suffices to apply (1) to  $-\Delta$ . Hence we prove (1). Note that the hypotheses imply  $e^{+\infty} > i + d_{\mathcal{F}}$ , hence by lemma 2.2.26 any floor diagram  $\mathcal{D}$  with Newton polygon  $\Delta$ , genus 0 and codegree at most  $i$  has a unique maximal floor. By lemma 2.2.28 the order is total on the  $a - i - 1$  highest floors of  $\mathcal{D}$ , and in particular on its  $a - \lfloor a/2 \rfloor + 1$  highest floors. Let  $v_{i+2} \prec \cdots \prec v_a$  be the highest floors. If there is a sink attached to a vertex lower than  $v_{a-i}$ , then by  $A^+$  operations we see that  $\text{codeg}(\mathcal{D}) > i$ . Thus  $\mathcal{D}$  looks like the diagram of figure 2.13. For  $\lfloor a/2 \rfloor \leq k \leq a - 1$  let  $e_k$  be the bounded edge between  $v_k$  and  $v_{k+1}$ .

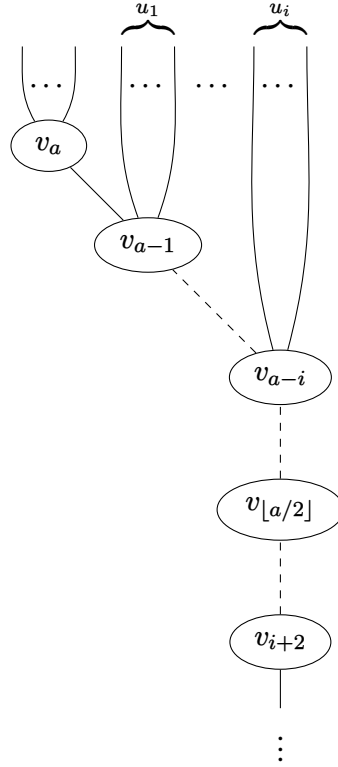

Figure 2.13 – A diagram with a total order on its highest vertices.

▷ If  $a - i \leq k \leq a - 1$ , the weight of  $e_k$  is

$$\begin{aligned}
 w(e_k) &= e^{+\infty} - \sum_{j=a-k}^i u_j + \sum_{j=k+1}^a \operatorname{div}(v_j) \\
 &> i + \left( a - \left\lfloor \frac{a}{2} \right\rfloor + 1 \right) d_{\mathcal{F}} - \operatorname{codeg}(\mathcal{D}) - (a - k) d_{\mathcal{F}} \\
 &\geq i - \operatorname{codeg}(\mathcal{D}) + \left( \frac{a}{2} + 1 - i \right) d_{\mathcal{F}} \\
 &\geq i - \operatorname{codeg}(\mathcal{D}).
 \end{aligned}$$

In particular  $w(e_{a-i}) > i - \operatorname{codeg}(\mathcal{D}) + (a/2 + 1 - i) d_{\mathcal{F}}$ .

▷ If  $\lfloor a/2 \rfloor \leq k \leq a - i - 1$ , the weight of  $e_k$  is

$$\begin{aligned}
 w(e_k) &= w(e_{a-i}) + u_i + \sum_{j=k+1}^{a-i} \operatorname{div}(v_j) \\
 &> i - \operatorname{codeg}(\mathcal{D}) + \left( \frac{a}{2} + 1 - i \right) d_{\mathcal{F}} - (a - i - k) d_{\mathcal{F}}
 \end{aligned}$$

$$\begin{aligned} &\geq i - \text{codeg}(\mathcal{D}) + \left( \left\lfloor \frac{a}{2} \right\rfloor - \frac{a}{2} + 1 \right) d_{\mathcal{F}} \\ &\geq i - \text{codeg}(\mathcal{D}). \end{aligned}$$

□

**Lemma 2.2.30.** *Let  $g \geq 0$  and  $M, i > 0$ . Let  $\Delta$  be an  $h$ -transverse polygon. Assume  $e^{\pm\infty}(\Delta) > M(g+1) + i$ . Let  $\mathcal{D}$  be a floor diagram of Newton polygon  $\Delta$ , genus  $g$  and  $\text{codeg}(\mathcal{D}) \leq i$ . Then the vertices of  $\mathcal{D}$  are totally ordered. Moreover, for any two consecutive floors of  $\mathcal{D}$  there is a bounded edge  $e$  between them with weight  $w(e) > M$ .*

*Proof.* Let  $w_k$  be the sum of the weights of the edges between the floors  $k$  and  $k+1$  in a floor diagram of Newton polygon  $\Delta$ , genus  $g$  and codegree 0. Then  $w_k$  is the number of integer points on a horizontal slice of  $\Delta$ , see the proof of proposition 2.2.24 and figure 2.11. In particular, since  $\Delta$  is convex one has  $w_k \geq \min(e^{-\infty}(\Delta), e^{+\infty}(\Delta)) > M(g+1) + i$ .

Let  $\mathcal{D}$  be a floor diagram of Newton polygon  $\Delta$  and genus  $g$  and codegree at most  $i$ . By a sequence of at most  $\text{codeg}(\mathcal{D})$  operations  $A^{\pm}$  and  $B^{L,R}$ , we obtain from  $\mathcal{D}$  a diagram  $\mathcal{D}_0$  of genus  $g$  and codegree 0. Let  $v_1^0 < \dots < v_a^0$  be the vertices of  $\mathcal{D}_0$ , and  $v_k$  be the vertex of  $\mathcal{D}$  which is mapped to  $v_k^0$  by the sequence of operations. Let  $\tilde{w}_k$  be the sum of the weights of the edges adjacent to  $v_k$  and  $v_{k+1}$ ; it may be 0 if there is no such edge.

Each of the operations of the sequence increases by at least 1 the weight of at least one edge, i.e.  $\tilde{w}_k \leq w_k$ . If for some  $k$  one has  $\tilde{w}_k < w_k - \text{codeg}(\mathcal{D})$ , then

$$\text{deg}(\mathcal{D}) < \text{deg}(\mathcal{D}_0) - \text{codeg}(\mathcal{D})$$

which is a contradiction since  $\text{deg}(\mathcal{D}) = \text{deg}(\mathcal{D}_0) - \text{codeg}(\mathcal{D})$ . Hence for any  $1 \leq k \leq a-1$  one has

$$\tilde{w}_k \geq w_k - \text{codeg}(\mathcal{D}) \geq w_k - i > (g+1)M.$$

In particular, there is at least one edge between the floors  $v_k$  and  $v_{k+1}$ , so that the floors are totally ordered in the diagram. Because  $\mathcal{D}$  has genus  $g$ , the total weight  $\tilde{w}_k$  is split into at most  $g+1$  edges. Hence at least one of them has  $w(e) > M$ . □

**Corollary 2.2.31.** *Let  $i \in \mathbb{N}$  and  $\Delta$  be an  $h$ -transverse polygon. Let  $\mathcal{D}$  be a floor diagram of Newton polygon  $\Delta$ , genus 0 and  $\text{codeg}(\mathcal{D}) \leq i$ . If  $e^{\pm\infty}(\Delta) > 2i - \text{codeg}(\mathcal{D})$  then the vertices of  $\mathcal{D}$  are totally ordered, and any bounded edge  $e$  of  $\mathcal{D}$  has a weight  $w(e) > i - \text{codeg}(\mathcal{D})$ .*

*Proof.* Apply lemma 2.2.30 with  $g = 0$  and  $M = i - \text{codeg}(\mathcal{D})$ . □



## 2.3 From tropical refined invariants to asymptotic refined invariants

### 2.3.1 Motivations

In section 2.2.2, tropical refined invariants are defined with multiplicities which are products of terms of the form

$$[n](q) = \frac{q^{n/2} - q^{-n/2}}{q^{1/2} - q^{-1/2}}.$$

However, as seen in section 1.3.2 some results suggest that the interesting part of the multiplicities is the numerators. Therefore, we explain in this section how to modify the multiplicities we count the floor diagrams with. This will turn the tropical refined invariant into another polynomial and we lead to the introduction of the *asymptotic refined invariant* [BM24]. This framework will be more comfortable to state our results.

We assume we have already proved an invariance with respect to  $S$  in any genus, i.e. we defined  $G_g(\Delta, s)$  for any  $g$ , see chapter 3, theorem 3.1.3.

### 2.3.2 A new multiplicity

Let  $(\mathcal{D}, m)$  be a marked floor diagram and  $S$  be a pairing compatible with  $m$ . Recall the notations  $E_0$ ,  $E_1$  and  $E_2$  used in definition 2.2.15. We consider the partitions

$$E_0 = E_0^0 \sqcup E_0^\infty, \quad E_1 = E_1^0 \sqcup E_1^\infty \quad \text{and} \quad E_2 = E_2^{00} \sqcup E_2^{0\infty} \sqcup E_2^{\infty\infty},$$

where the superscript 0 stands for “bounded” and the superscript  $\infty$  stands for “infinite”, for instance  $E_2^{0\infty} = \{\{e, e'\} \in E_2 \mid e \text{ bounded and } e' \text{ infinite}\}$ . For an integer  $n$  and a formal variable  $x$  we set the notation  $x_n = 1 - x^n$ . We introduce the following multiplicity.

**Definition 2.3.1.** *The asymptotic  $S$ -multiplicity of the marked floor diagram  $(\mathcal{D}, m)$  is*

$$\begin{aligned} \mu_S^*(\mathcal{D}, m)(x) = & x^{\text{codeg}(\mathcal{D})} \prod_{e \in E_0^0} x_{w(e)}^2 \prod_{e \in E_0^\infty} x_1 \prod_{e \in E_1^0} x_{2w(e)} \prod_{e \in E_1^\infty} (1+x) \\ & \prod_{\{e, e'\} \in E_2^{00}} x_{w(e)} x_{w(e')} x_{w(e)+w(e')} \prod_{\{e, e'\} \in E_2^{0\infty}} x_{w(e)} x_{w(e)+1} \prod_{\{e, e'\} \in E_2^{\infty\infty}} x_2 \end{aligned}$$

if  $S$  and  $m$  are compatible, and 0 otherwise.

We consider the quantity

$$G_g^*(\Delta, S)(x) = \sum_{(\mathcal{D}, m)} \mu_S^*(\mathcal{D}, m)(x)$$

where the sum runs over the isomorphism classes of marked floor diagrams with Newton polygon  $\Delta$  and genus  $g$ .

For  $P(q) \in \mathbb{C}[q^{1/2}, q^{-1/2}]$  a symmetric Laurent polynomial we set

$$\tilde{P}(x) = x^{\deg(P)} P(x) \in \mathbb{C}[x]$$

i.e. we dispel the negative powers. If  $P(q) = a_0 q^d + a_1 q^{d-1} + \dots$  then  $\tilde{P}(x) = a_0 + a_1 x + \dots$ , i.e. the coefficient  $a_i$  of codegree  $i$  in  $P(q)$  becomes the coefficient of degree  $i$  of  $\tilde{P}(x)$ . Note also that  $\widetilde{PQ} = \tilde{P}\tilde{Q}$  for  $P, Q \in \mathbb{C}[q^{1/2}, q^{-1/2}]$ . We consider the following formal series :

$$A = \frac{1}{1-x} \quad \text{and} \quad B = \frac{1}{1-x^2}.$$

**Proposition 2.3.2.** *Let  $g \in \mathbb{N}$  and  $\Delta$  be an  $h$ -transverse polygon. Let  $s \in \{0, \dots, s_{\max}(\Delta, g)\}$  and  $S$  be a pairing of order  $s$ . One has*

$$\tilde{G}_g(\Delta, s)(x) = A^{y(\Delta)-2+2g-2s} B^s G_g^*(\Delta, S)(x).$$

*In particular  $G_g^*(\Delta, S)(x)$  does not depend on the choice of the pairing  $S$  of order  $s$ , and we can write  $G_g^*(\Delta, s)(x)$ .*

*Proof.* For any diagram  $\mathcal{D}$  one has

$$\deg(G_g(\Delta, s)) = \deg(\mathcal{D}) + \text{codeg}(\mathcal{D}) = \deg(\mu_S(\mathcal{D}, m)) + \text{codeg}(\mathcal{D}),$$

hence

$$\tilde{G}_g(\Delta, s) = \sum_{(\mathcal{D}, m)} x^{\text{codeg}(\mathcal{D})} \tilde{\mu}_S(\mathcal{D}, m).$$

For quantum integers one has

$$\widetilde{[n]}(x) = \frac{1-x^n}{1-x}, \quad \widetilde{[n]^2}(x) = \left( \frac{1-x^n}{1-x} \right)^2, \quad \text{and} \quad \widetilde{[n]_2}(x) = \frac{1-x^{2n}}{1-x^2}$$

and we get

$$\tilde{\mu}_S(\mathcal{D}, m)(x) = \prod_{e \in E_0} \left( \frac{1-x^{w(e)}}{1-x} \right)^2 \prod_{e \in E_1} \frac{1-x^{2w(e)}}{1-x^2} \prod_{\{e, e'\} \in E_2} \frac{(1-x^{w(e)})(1-x^{w(e')})(1-x^{w(e)+w(e')})}{(1-x)^2(1-x^2)}.$$

The product over  $E_0$  is rewritten

$$\prod_{e \in E_0^0} \left( \frac{1-x^{w(e)}}{1-x} \right)^2 \prod_{e \in E_0^\infty} \frac{1-x}{1-x} = A^{2|E_0^0|+|E_0^\infty|} \prod_{e \in E_0^0} x_{w(e)}^2 \prod_{e \in E_0^\infty} x_1,$$

the one over  $E_1$  becomes

$$\prod_{e \in E_1^0} \frac{1 - x^{2w(e)}}{1 - x^2} \prod_{e \in E_1^\infty} \frac{(1-x)(1+x)}{1-x^2} = B^{|E_1|} A^{-|E_1^\infty|} \prod_{e \in E_1^0} x_{2w(e)} \prod_{e \in E_1^\infty} (1+x),$$

and the one over  $E_2$  gives

$$\begin{aligned} & \prod_{\{e, e'\} \in E_2^{00}} \frac{(1-x^{w(e)})(1-x^{w(e')})(1-x^{w(e)+w(e')})}{(1-x)^2(1-x^2)} \prod_{\{e, e'\} \in E_2^{0\infty}} \frac{(1-x^{w(e)})(1-x^{w(e)+1})}{(1-x)(1-x^2)} \prod_{\{e, e'\} \in E_2^{\infty\infty}} \frac{1-x^2}{1-x^2} \\ &= A^{2|E_2^{00}|+|E_2^{0\infty}|} B^{|E_2|} \prod_{\{e, e'\} \in E_2^{00}} x_{w(e)} x_{w(e')} x_{w(e)+w(e')} \prod_{\{e, e'\} \in E_2^{0\infty}} x_{w(e)} x_{w(e)+1} \prod_{\{e, e'\} \in E_2^{\infty\infty}} x_2. \end{aligned}$$

Putting together the three products, the total power for  $B$  is  $|E_1| + |E_2| = s$ . Given the relations

$$\begin{cases} |E_1| + |E_2| &= s \\ |V| - |E^b| &= 1 - g \\ 2|V| + |E^\infty| &= y(\Delta) \\ |E^\alpha| &= |E_0^\alpha| + |E_1^\alpha| + 2|E_2^{\alpha\alpha}| + |E_2^{\alpha\beta}|, \text{ where } \{\alpha, \beta\} = \{0, \infty\} \end{cases}$$

the total power for  $A$  is  $y(\Delta) - 2 + 2g - 2s$ . Hence we eventually get

$$\widetilde{G}_g(\Delta, s)(x) = A^{y(\Delta)-2+2g-2s} B^s \sum_{(\mathcal{D}, m)} \mu_S^*(\mathcal{D}, m)(x) = A^{y(\Delta)-2+2g-2s} B^s G_g^*(\Delta, S)(x).$$

□

*Remark 2.3.3.* As  $G_g^*(\Delta, S)$  is independent of the choice of the pairing  $S$  as long as it has order  $s$ , we will fix  $S = \{\{1, 2\}, \dots, \{2s-1, 2s\}\}$ . If moreover we assume  $e^{-\infty}(\Delta) \geq i + 2s$ , then for any marked floor diagram  $(\mathcal{D}, m)$  with Newton polygon  $\Delta$ , codegree at most  $i$  and compatible with  $S$ , the elements in  $m^{-1}(\{1, \dots, 2s\})$  are all sources. Hence the multiplicity  $\mu_S^*(\mathcal{D}, m)$  is just

$$\mu_S^*(\mathcal{D}, m)(x) = x^{\text{codeg}(\mathcal{D})} (1-x)^{e^\infty(\mathcal{D})} \left( \frac{1+x}{1-x} \right)^s \prod_{e \in E^0(\mathcal{D})} (1-x^{w(e)})^2.$$

The degree of  $\mu_S^*(\mathcal{D}, m)$  is

$$\begin{aligned} \deg(\mu_S^*(\mathcal{D}, m)) &= \text{codeg}(\mathcal{D}) + e^\infty(\mathcal{D}) + 2 \sum_{e \in E^0(\mathcal{D})} w(e) \\ &= \text{codeg}(\mathcal{D}) + e^\infty(\mathcal{D}) + 2 \deg(\mathcal{D}) + 2|E^0(\mathcal{D})| \end{aligned}$$

Because of the relations  $\deg(\mathcal{D}) = g_{\max}(\Delta) - g - \text{codeg}(\mathcal{D})$ ,  $|V(\mathcal{D})| - |E^0(\mathcal{D})| = 1 - g$ ,  $y(\Delta) =$

$2|V(\mathcal{D})| + e^\infty(\mathcal{D})$  and  $\text{Area}(\Delta) = g_{\max}(\Delta) + y(\Delta)/2 - 1$ , where  $\text{Area}$  denotes the Euclidean area, one has

$$\deg(\mu_S^*(\mathcal{D}, m)) = 2\text{Area}(\Delta) - \text{codeg}(\mathcal{D})$$

**Definition 2.3.4.** *Let  $g \in \mathbb{N}$  and  $\Delta$  be an  $h$ -transverse polygon. Let  $s \in \{0, \dots, s_{\max}(\Delta, g)\}$ . We denote by  $G_g^*(\Delta, s)$  the quantity  $G_g^*(\Delta, S)$ , where  $S$  is any pairing of order  $s$ .*

As we saw in proposition 2.3.2, computing the generating series of the functions which give the codegree  $i$  coefficients of  $G_g(\Delta, s)$  is equivalent to computing the generating series of the functions that gives the degree  $i$  coefficients of  $G_g^*(\Delta, s)$ . This remark leads to the introduction of *asymptotic refined invariants*.

### 2.3.3 Asymptotic refined invariants

The quantity  $G_g^*(\Delta, s)(x)$  is a polynomial, i.e. an element of  $\mathbb{Z}[x]$ . Its degree is  $2\text{Area}(\Delta)$ . However we can see it as a formal series, i.e. an element of  $\mathbb{Z}[[x]]$ . Because  $\mathbb{Z}[[x]]$  is a valuation ring, we can endow it with the topology coming from the associated ultrametric distance. A basis of neighborhoods of 0 for this topology is given by the ideals  $x^n\mathbb{Z}[[x]]$ , so that  $f \in \mathbb{Z}[[x]]$  is close to 0 if  $f = 0 \pmod{x^n}$  for  $n \in \mathbb{N}$  large enough. We prefer to use  $\mathbb{Z}[[x]]$  instead of  $\mathbb{Z}[x]$  because it is a complete space, more suited to express our asymptotic result.

Meanwhile, for a fan  $\mathcal{F}$  we have a notion of neighborhood of infinity in the set of dual polygons  $D(\mathcal{F})$  : for  $C > 0$  we say that  $\Delta > C$  if any edge of  $\Delta$  has integral length greater than  $C$ .

The main goal of this thesis is to study the existence and give formulas for functions

$$AR_{g,s}^{\mathcal{F}} : D(\mathcal{F}) \rightarrow \mathbb{Z}[[x]]$$

which are polynomials<sup>1</sup> with coefficients in  $\mathbb{Z}[[x]]$  such that for any  $s \in \mathbb{N}$  one has

$$G_g^*(\Delta, s) = AR_{g,s}^{\mathcal{F}}(\Delta) + o(1) \in \mathbb{Z}[[x]],$$

where the asymptotic development takes place when  $\Delta \rightarrow +\infty$  in  $D(\mathcal{F})$ .

**Definition 2.3.5 (Asymptotic refined invariants).** *If they exist, such functions  $AR_{g,s}^{\mathcal{F}}$  are called asymptotic refined invariants.*

To rephrase it, if the asymptotic refined invariant  $AR_{g,s}^{\mathcal{F}}$  exists then for any  $i \in \mathbb{N}$ , any polygon  $\Delta \in D(\mathcal{F})$  large enough with respect to  $i$ , and any  $s \in \{0, \dots, s_{\max}(\Delta, g)\}$  one has

$$G_g^*(\Delta, s) = AR_{g,s}^{\mathcal{F}}(\Delta) \pmod{x^i},$$

i.e. the power series  $AR_{g,s}^{\mathcal{F}}(\Delta)$  correctly gives the first  $i$  coefficients of  $G_g^*(\Delta, s)$ .

1. By ‘‘polynomial in  $\Delta$ ’’ we mean polynomial in  $\mathcal{L}_\Delta^2$ ,  $K_{X_\Delta} \cdot \mathcal{L}_\Delta$ ,  $y(\Delta)$  and  $\chi(\Delta)$ .

Moreover, if  $AR_{g,s}^{\mathcal{F}}$  exists then the coefficients of  $AR_{g,s}^{\mathcal{F}}(\Delta) \in \mathbb{Z}[[x]]$  are polynomials in  $\Delta$  and  $s$ . Thus, we actually study the polynomiality of the coefficients of  $G_g^*(\Delta, s)$ , i.e. of  $\widetilde{G}_g(\Delta, s)$ , i.e. of  $G_g(\Delta, s)$ . Note that the polynomial behaviour is not affected by the multiplication or division by  $A(x)^{y(\Delta)-2+2g-2s}B(x)^s$ , whose coefficients are also polynomials in  $\Delta$  and  $s$ .

*Remark 2.3.6.* This formulation as an asymptotic development is inspired by a reformulation of Göttsche's conjecture [Göt98], which states that for a polarized surface  $(X, \mathcal{L})$  the number  $N^\delta(\mathcal{L})$  is given by a (universal) polynomial  $P_\delta(\mathcal{L}) = P_\delta(\mathcal{L}^2, \mathcal{L} \cdot K_X, K_X^2, c_2(X))$ , provided  $\mathcal{L}$  is sufficiently ample. In other words, considering the discrete topology of  $\mathbb{Z}$  one has

$$N^\delta(\mathcal{L}) = P_\delta(\mathcal{L}) + o(1).$$

# Göttsche-Schroeter invariants in higher genus

---

Göttsche-Schroeter invariants are tropical invariants defined in genus 0 that we can compute combinatorially using floor diagrams, see theorem 2.2.16. In the calculation we need to choose a pairing  $S$  of order  $s$ , and we know that the result will be independent of the choice of  $S$  as long as it has order  $s$ .

The main result of this chapter is theorem 3.1.3. It states that in any genus we can apply the recipe of theorem 2.2.16, i.e. choose a  $S$  and compute for this pairing, and the result will be independent of the choice of  $S$  as long as it has order  $s$ . Hence we get a new combinatorial invariant that we denote  $G_g(\Delta, s) \in \mathbb{Z}[q^{\pm 1}]$  and call *Göttsche-Schroeter invariant of genus  $g$* . As wished is [BJP22, remark 2.14] the proof is entirely combinatorial and does not go through tropical geometry. In the particular case of genus 1, we combinatorially recover the invariants of [SS18]<sup>1</sup>. We then prove some results regarding this invariant. These results extend the ones we can find in [BJP22]. In particular, we prove theorem 3.1.8 which generalizes [BJP22, theorem 1.7] to any genus. Last, we perform computations on some small examples. This leads to few conjectures that may give evidence that this *combinatorial* invariant may have a *geometric* interpretation.

## 3.1 Refined invariants in the non-rational case

### 3.1.1 Definition of $G_g(\Delta, s)$

**Definition 3.1.1.** Let  $\Delta$  be an  $h$ -transverse polygon,  $g \in \mathbb{N}$ ,  $s \in \mathbb{N}$  and  $S$  be a pairing of order  $s$  of  $\{1, \dots, 2s_{\max}(\Delta, g)\}$ . We define

$$G_g(\Delta, S) = \sum_{(\mathcal{D}, m)} \mu_S(\mathcal{D}, m) \in \mathbb{Z}[q^{\pm 1}]$$

where the sum runs over the isomorphism classes of marked floor diagrams with Newton polygon  $\Delta$  and genus  $g$ .

---

1. We also recover the invariants of [SS24] in any genus, when the polygon  $\Delta$  is  $h$ -transverse.

The goal is now to turn the  $S$ -dependence into a  $s$ -dependence. We start with a technical lemma on quantum integers. Remember we denote  $[n]^2 = [n](q)^2$  and  $[n]_2 = [n](q^2)$ .

**Lemma 3.1.2.** *Let  $a, b \in \mathbb{Z}$  be integers. Then*

$$\begin{aligned} 2[a][b][a+b] &= [2] \left( [a+b]^2[a]_2 - [a+b]_2[a]^2 \right) \\ &= [2] \left( [a]^2[b]_2 + [a]_2[b]^2 \right). \end{aligned}$$

*Proof.* The first quantity is

$$\begin{aligned} 2[a][b][a+b] &= 2 \frac{(q^{a/2} - q^{-a/2})(q^{b/2} - q^{-b/2})(q^{(a+b)/2} - q^{-(a+b)/2})}{(q^{1/2} - q^{-1/2})^3} \\ &= 2 \frac{q^{a+b} - q^{-a-b} - q^a + q^{-a} - q^b + q^{-b}}{(q^{1/2} - q^{-1/2})^3}. \end{aligned}$$

To show the equalities, for any integers  $c, d$  we first compute

$$\begin{aligned} [2][c]^2[d]_2 &= \frac{q - q^{-1}}{q^{1/2} - q^{-1/2}} \times \left( \frac{q^{c/2} - q^{-c/2}}{q^{1/2} - q^{-1/2}} \right)^2 \times \frac{q^c - q^{-c}}{q - q^{-1}} \\ &= \frac{q^{c+d} - q^{c-d} - 2(q^d - q^{-d}) + q^{-c+d} - q^{-c-d}}{(q^{1/2} - q^{-1/2})^3}. \end{aligned}$$

Applying this to  $(c, d) = (a+b, a)$  and  $(c, d) = (a, a+b)$  we deduce that

$$\begin{aligned} [2] \left( [a+b]^2[a]_2 - [a+b]_2[a]^2 \right) &= \frac{q^{2a+b} - q^b - 2(q^a - q^{-a}) + q^{-b} - q^{-2a-b}}{(q^{1/2} - q^{-1/2})^3} \\ &\quad - \frac{q^{2a+b} - q^{-b} - 2(q^{a+b} - q^{-a-b}) + q^b - q^{-2a-b}}{(q^{1/2} - q^{-1/2})^3} \\ &= 2 \frac{q^{a+b} - q^{-a-b} - q^a + q^{-a} - q^b + q^{-b}}{(q^{1/2} - q^{-1/2})^3} \\ &= 2[a][b][a+b], \end{aligned}$$

and applying it to  $(c, d) = (a, b)$  and  $(c, d) = (b, a)$  we get

$$\begin{aligned} [2] \left( [a]^2[b]_2 + [a]_2[b]^2 \right) &= \frac{q^{a+b} - q^{a-b} - 2(q^b - q^{-b}) + q^{-a+b} - q^{-a-b}}{(q^{1/2} - q^{-1/2})^3} \\ &\quad + \frac{q^{a+b} - q^{-a+b} - 2(q^a - q^{-a}) + q^{a-b} - q^{-a-b}}{(q^{1/2} - q^{-1/2})^3} \\ &= 2 \frac{q^{a+b} - q^{-a-b} - q^a + q^{-a} - q^b + q^{-b}}{(q^{1/2} - q^{-1/2})^3} \\ &= 2[a][b][a+b] \end{aligned}$$

so the three quantities are equal.  $\square$

We can now prove the main result of this section.

**Theorem 3.1.3.** *Let  $\Delta$  be  $h$ -transverse polygon and  $g \in \mathbb{N}$ . Let  $s \in \mathbb{N}$  and  $S, S'$  be two pairings of order  $s$ . Then  $G_g(\Delta, S) = G_g(\Delta, S')$ .*

The strategy to prove the theorem is the following. We will determine a partition  $(P_k)_k$  of the marked floor diagrams such that for any  $k$  one has

$$\sum_{(\mathcal{D}, m) \in P_k} \mu_S(\mathcal{D}, m) = \sum_{(\mathcal{D}, m) \in P_k} \mu_{S'}(\mathcal{D}, m).$$

To do so, we inductively construct the partition  $(P_k)_k$ . We start with a marked floor diagram  $(\mathcal{D}_1, m_1)$  and we determine a set  $P_1$  of marked floor diagrams such that  $P_1$  contains  $(\mathcal{D}_1, m_1)$  and

$$\sum_{(\mathcal{D}, m) \in P_1} \mu_S(\mathcal{D}, m) = \sum_{(\mathcal{D}, m) \in P_1} \mu_{S'}(\mathcal{D}, m).$$

We then choose another marked floor diagram  $(\mathcal{D}_2, m_2) \notin P_1$ , and similarly determine a set  $P_2$  disjoint from  $P_1$ , etc. Hence, given an arbitrary marked floor diagram it suffices to give the part  $P$  of the partition it is contained in. More precisely, in the proof we introduce *partial markings* and we will simultaneously handle the case of several marked diagrams, all coming from the same *partial* marked diagram.

*Proof of theorem 3.1.3.* It is sufficient to suppose that  $S$  and  $S'$  differ by one pair, and we can assume that this pair is  $\{i, i+1\} \in S$  and  $\{i+1, i+2\} \in S'$ . Given  $\mathcal{D}$  a floor diagram of Newton polygon  $\Delta$  and genus  $g$ , a *partial marking* of  $\mathcal{D}$  is a map that associates to all but three elements of  $\mathcal{D}$  an integer of  $\{1, \dots, n(\mathcal{D})\} \setminus \{i, i+1, i+2\}$  in a bijective and increasing way. A partial marking gives several markings by labeling the three remaining elements of  $\mathcal{D}$  with  $i, i+1$  and  $i+2$ .

Let  $\mathcal{D}$  be a floor diagram of Newton polygon  $\Delta$  and genus  $g$ . Assume we are given a partial marking of  $\mathcal{D}$ . We will investigate the possibilities to construct a marked floor diagram from this data. To do so, for any relative positions of the three elements left aside by the partial marking, we look at the possible choices to extend the partial marking. We will distinguish cases according to the number of vertices left aside by the partial marking. In all the proof,  $W$  will be the contribution to  $\mu_S(\mathcal{D}, m)$  and  $\mu_{S'}(\mathcal{D}, m)$  of the edges marked by the partial marking.

**3 vertices.** In that case both  $S$  and  $S'$  are incompatible whatever the marking  $m$  extending the partial marking is, i.e.

$$\mu_S(\mathcal{D}, m) = \mu_{S'}(\mathcal{D}, m) = 0.$$



So take  $P = \{(\mathcal{D}, m), m \text{ extension of the partial marking}\}$ .

**2 vertices.** The unique edge left aside by the partial marking can :

- ▷ link the two vertices (figure 3.1a),
- ▷ be adjacent to only one of the two edges (figure 3.1b, and the symmetric case where the edge is above the vertex),
- ▷ or be adjacent to none of the vertices (figure 3.1c).

On those pictures we do not represent other vertices and edges of  $\mathcal{D}$ .

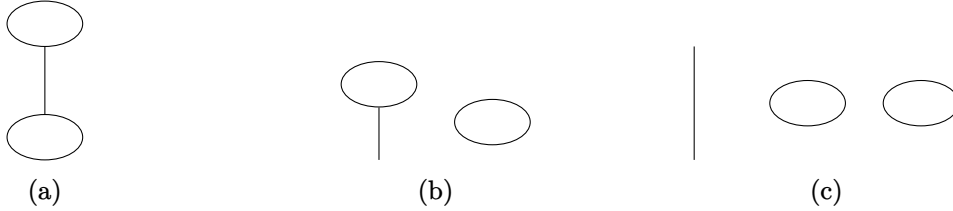

Figure 3.1 – Possible configurations with 2 vertices.

We deal with the three cases separately.

(a) There is only one possible marking  $m$  and one has

$$\mu_S(\mathcal{D}, m) = \mu_{S'}(\mathcal{D}, m)$$

so take  $P = \{(\mathcal{D}, m)\}$ .

(b) There are three possible markings. Let  $m_k$  be the extension where the right vertex is  $i + k$  for  $k = 0, 1, 2$ . The marking  $m_1$  is incompatible with both  $S$  and  $S'$  i.e.  $\mu_S(\mathcal{D}, m_1) = \mu_{S'}(\mathcal{D}, m_1) = 0$ , and one has  $\mu_S(\mathcal{D}, m_0) = \mu_{S'}(\mathcal{D}, m_2) = 0$  and  $\mu_S(\mathcal{D}, m_2) = \mu_{S'}(\mathcal{D}, m_0)$ . Thus

$$\mu_S(\mathcal{D}, m_0) + \mu_S(\mathcal{D}, m_1) + \mu_S(\mathcal{D}, m_2) = \mu_{S'}(\mathcal{D}, m_0) + \mu_{S'}(\mathcal{D}, m_1) + \mu_{S'}(\mathcal{D}, m_2)$$

and we take  $P = \{(\mathcal{D}, m_0), (\mathcal{D}, m_1), (\mathcal{D}, m_2)\}$ .

(c) Any marking  $m$  is incompatible with both  $S$  and  $S'$  i.e.

$$\mu_S(\mathcal{D}, m) = \mu_{S'}(\mathcal{D}, m) = 0$$

and take  $P = \{(\mathcal{D}, m), m \text{ extension of the partial marking}\}$ .

**1 vertex.** The unique vertex left aside by the partial marking can :

- ▷ be adjacent to both edges (figure 3.2a where the edges can share a second common vertex or not, the symmetric case where the edges are above the vertex, and figure 3.2b),
- ▷ be adjacent to one of the two edges (figures 3.2c where the edges are adjacent to a common vertex, the symmetric case where the common vertex is above the edges, figure 3.2d and its symmetric case),
- ▷ or be adjacent to none of the edges (figure 3.2e if the edges are adjacent to at least one common vertex, its symmetric case, and figure 3.2f).

On those pictures, solid lines are for elements left aside by the partial marking, and we represent other vertices with dashed lines if they are relevant (i.e. play a role) in the calculations.

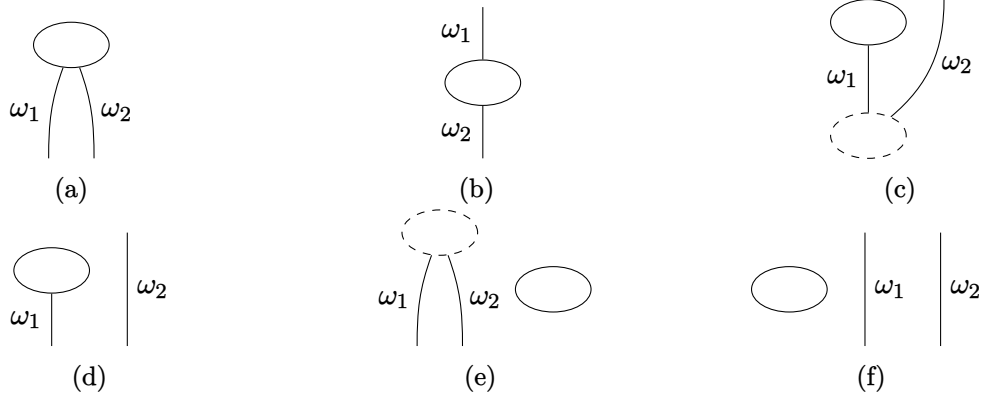

Figure 3.2 – Possible configurations with 1 vertex.

We deal with the different cases separately.

- (a) Denote  $m_0$  (resp.  $m_1$ ) the marking where the left edge is  $i$  (resp.  $i + 1$ ). Then one has  $\mu_S(\mathcal{D}, m_0) = \mu_S(\mathcal{D}, m_1) = \frac{[\omega_1][\omega_2][\omega_1 + \omega_2]}{[2]}W$ ,  $\mu_{S'}(\mathcal{D}, m_0) = [\omega_1]^2[\omega_2]_2W$  and  $\mu_{S'}(\mathcal{D}, m_1) = [\omega_1]_2[\omega_2]^2W$ . Lemma 3.1.2 shows that

$$\mu_S(\mathcal{D}, m_0) + \mu_S(\mathcal{D}, m_1) = \mu_{S'}(\mathcal{D}, m_0) + \mu_{S'}(\mathcal{D}, m_1)$$

so take  $P = \{(\mathcal{D}, m_0), (\mathcal{D}, m_1)\}$ .

- (b,c) If the diagram  $\mathcal{D}$  is in case (b), it might be necessary to include marked diagrams of case (c) to the part  $P$  containing  $(\mathcal{D}, m)$ , where  $m$  is the unique marking extending the partial marking of  $\mathcal{D}$ . For that reason, cases (b) and (c) are handled together.

In case (b), first assume  $\omega_1 = \omega_2$ . Then one has  $\mu_S(\mathcal{D}, m) = \mu_{S'}(\mathcal{D}, m)$  and we take  $P = \{(\mathcal{D}, m)\}$  ; when  $\omega_1 \neq \omega_2$  there is no corresponding diagram of case (c).

Otherwise  $\omega_1 \neq \omega_2$  and we assume  $\omega_2 > \omega_1$ . In particular, one has  $\omega_2 > 1$  so the edge with weight  $\omega_2$  cannot be an infinite edge and is necessarily adjacent to a second vertex. Moreover  $\omega_2$  can be written  $\omega_1 + (\omega_2 - \omega_1)$  with both terms positive. In the end, this case (b) is related to case (c) via an operation  $A^+$ , see figure 3.3. Conversely any case (c) gives a case (b) with  $\omega_2 > \omega_1$  via an operation  $A^+$ .

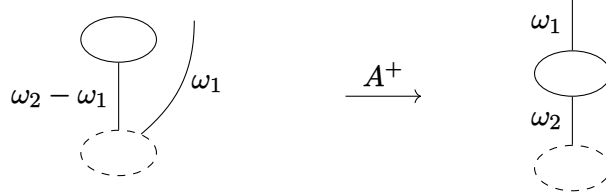

Figure 3.3 – Passing from case (c) to case (b).

Let  $\mathcal{D}'$  be the floor diagram of case (c) which gives the diagram  $\mathcal{D}$  of case (b) with the  $A^+$  operation of figure 3.3. Let  $m'_k$  be the marking of  $\mathcal{D}'$  where the right edge is  $i + k$  for  $k = 0, 1, 2$ . One has :

$$\begin{aligned} \triangleright \mu_S(\mathcal{D}', m'_0) &= \frac{[\omega_1][\omega_2 - \omega_1][\omega_2]}{[2]} W \text{ and } \mu_{S'}(\mathcal{D}', m'_0) = [\omega_1]^2[\omega_2 - \omega_1]_2 W, \\ \triangleright \mu_S(\mathcal{D}', m'_1) &= \frac{[\omega_1][\omega_2 - \omega_1][\omega_2]}{[2]} W \text{ and } \mu_{S'}(\mathcal{D}', m'_1) = 0, \\ \triangleright \mu_S(\mathcal{D}', m'_2) &= [\omega_1]^2[\omega_2 - \omega_1]_2 W \text{ and } \mu_{S'}(\mathcal{D}', m'_2) = 0. \end{aligned}$$

For  $\mathcal{D}$  we have  $\mu_S(\mathcal{D}, m) = [\omega_1]^2[\omega_2]_2 W$  and  $\mu_{S'}(\mathcal{D}, m) = [\omega_1]_2[\omega_2]^2 W$ . Hence taking  $a = \omega_1$  and  $b = \omega_2 - \omega_1$  in lemma 3.1.2 we see that

$$\begin{aligned} &\mu_S(\mathcal{D}, m) + \mu_S(\mathcal{D}', m'_0) + \mu_S(\mathcal{D}', m'_1) + \mu_S(\mathcal{D}', m'_2) \\ &= \mu_{S'}(\mathcal{D}, m) + \mu_{S'}(\mathcal{D}', m'_0) + \mu_{S'}(\mathcal{D}', m'_1) + \mu_{S'}(\mathcal{D}', m'_2) \end{aligned}$$

and we can take  $P = \{(\mathcal{D}, m), (\mathcal{D}', m'_0), (\mathcal{D}', m'_1), (\mathcal{D}', m'_2)\}$ . If  $\omega_1 > \omega_2$  the proof is analogous using the symmetric case of figure 3.2c and an operation  $A^-$ .

- (d) This is similar to figure 3.1b. There are three possible markings. Let  $m_k$  be the extension where the right edge is  $i + k$  for  $k = 0, 1, 2$ . The marking  $m_1$  is incompatible with both  $S$  and  $S'$  i.e.  $\mu_S(\mathcal{D}, m_1) = \mu_{S'}(\mathcal{D}, m_1) = 0$ , and one has  $\mu_S(\mathcal{D}, m_0) = \mu_{S'}(\mathcal{D}, m_2) = 0$  and  $\mu_S(\mathcal{D}, m_2) = \mu_{S'}(\mathcal{D}, m_0)$  so

$$\mu_S(\mathcal{D}, m_0) + \mu_S(\mathcal{D}, m_1) + \mu_S(\mathcal{D}, m_2) = \mu_{S'}(\mathcal{D}, m_0) + \mu_{S'}(\mathcal{D}, m_1) + \mu_{S'}(\mathcal{D}, m_2)$$

and take  $P = \{(\mathcal{D}, m_0), (\mathcal{D}, m_1), (\mathcal{D}, m_2)\}$ .

(e) Let  $m_k$  and  $m'_k$  be the two markings where the vertex is  $i + k$  for  $k = 0, 1, 2$ . One has

$$\mu_S(\mathcal{D}, m_1) = \mu_{S'}(\mathcal{D}, m_1) = \mu_S(\mathcal{D}, m_0) = \mu_S(\mathcal{D}, m'_0) = \mu_{S'}(\mathcal{D}, m_2) = \mu_{S'}(\mathcal{D}, m'_2) = 0$$

and

$$\mu_S(\mathcal{D}, m_2) = \mu_S(\mathcal{D}, m'_2) = \mu_{S'}(\mathcal{D}, m_0) = \mu_{S'}(\mathcal{D}, m'_0) = \frac{[\omega_1][\omega_2][\omega_1 + \omega_2]}{[2]}W,$$

so

$$\begin{aligned} & \mu_S(\mathcal{D}, m_0) + \mu_S(\mathcal{D}, m'_0) + \mu_S(\mathcal{D}, m_1) + \mu_S(\mathcal{D}, m'_1) + \mu_S(\mathcal{D}, m_2) + \mu_S(\mathcal{D}, m'_2) \\ &= \mu_{S'}(\mathcal{D}, m_0) + \mu_{S'}(\mathcal{D}, m'_0) + \mu_{S'}(\mathcal{D}, m_1) + \mu_{S'}(\mathcal{D}, m'_1) + \mu_{S'}(\mathcal{D}, m_2) + \mu_{S'}(\mathcal{D}, m'_2). \end{aligned}$$

and we take  $P = \{(\mathcal{D}, m_0), (\mathcal{D}, m'_0), (\mathcal{D}, m_1), (\mathcal{D}, m'_1), (\mathcal{D}, m_2), (\mathcal{D}, m'_2)\}$ .

(f) Any marking  $m$  is incompatible with both  $S$  and  $S'$  i.e.

$$\mu_S(\mathcal{D}, m) = \mu_{S'}(\mathcal{D}, m) = 0$$

and take  $P = \{(\mathcal{D}, m), m \text{ extension of the partial marking}\}$ .

**0 vertex.** The edges left aside by the partial marking can :

- ▷ be adjacent to a common vertex (figure 3.4a and the symmetric case where the vertex is below the edge),
- ▷ one can share at least a common vertex with any of the others, but the other two do not have a common vertex (figure 3.4b),
- ▷ two of them can share at least one common vertex, and the last edge has no common vertex with the other two (figure 3.4c),
- ▷ have no common vertex (figure 3.4d).

On those pictures, solid lines are for elements left aside by the partial marking, and we represent other vertices with dashed lines if they are relevant (i.e. play a role) in the calculations.

We deal with the different cases separately.

(a) There are six possible markings. The contributions are summed up in table 3.1, where  $(j, k, \ell)$  denotes the markings of the edges from left to right.

The sums of the two columns are the same, so these marked floor diagrams give the same contributions to  $G_g(\Delta, S)$  and  $G_g(\Delta, S')$  and we take  $P$  the set of these marked floor diagrams.



Figure 3.4 – Possible configurations with 0 vertex.

	$S$	$S'$
$(i, i + 1, i + 2)$	$\frac{[\omega_1][\omega_2][\omega_1 + \omega_2]}{[2]} [\omega_3]^2$	$\frac{[\omega_2][\omega_3][\omega_2 + \omega_3]}{[2]} [\omega_1]^2$
$(i, i + 2, i + 1)$	$\frac{[\omega_1][\omega_3][\omega_1 + \omega_3]}{[2]} [\omega_2]^2$	$\frac{[\omega_2][\omega_3][\omega_2 + \omega_3]}{[2]} [\omega_1]^2$
$(i + 1, i, i + 2)$	$\frac{[\omega_1][\omega_2][\omega_1 + \omega_2]}{[2]} [\omega_3]^2$	$\frac{[\omega_1][\omega_3][\omega_1 + \omega_3]}{[2]} [\omega_2]^2$
$(i + 1, i + 2, i)$	$\frac{[\omega_1][\omega_3][\omega_1 + \omega_3]}{[2]} [\omega_2]^2$	$\frac{[\omega_1][\omega_2][\omega_1 + \omega_2]}{[2]} [\omega_3]^2$
$(i + 2, i, i + 1)$	$\frac{[\omega_2][\omega_3][\omega_2 + \omega_3]}{[2]} [\omega_1]^2$	$\frac{[\omega_1][\omega_3][\omega_1 + \omega_3]}{[2]} [\omega_2]^2$
$(i + 2, i + 1, i)$	$\frac{[\omega_2][\omega_3][\omega_2 + \omega_3]}{[2]} [\omega_1]^2$	$\frac{[\omega_1][\omega_2][\omega_1 + \omega_2]}{[2]} [\omega_3]^2$

Table 3.1 – Contribution of the markings in case (a).

Note that, depending on the unshown part of the diagram and on the precise value of the weights, some markings may give isomorphic marked diagrams : there may be only 3 or 1 marked floor diagram instead of 6. However, in that case some of the weight among  $\omega_1$ ,  $\omega_2$  and  $\omega_3$  are equal, and removing the superfluous rows if the table does not affect the equality of the sums of the columns.

- (b) Similarly to the previous case we get table 3.2. We see that the sums of the two columns are the same, so these marked floor diagrams give the same contributions to  $G_g(\Delta, S)$  and  $G_g(\Delta, S')$  and we take  $P$  the set of these marked floor diagrams.
- (c) This is the same as in figure 3.2e. Let  $m_k$  and  $m'_k$  be the two markings where the right edge is  $i + k$  for  $k = 0, 1, 2$ . Both  $m_1$  and  $m'_1$  are incompatible with  $S$  and  $S'$ , and the contributions of  $m_0$  and  $m'_0$  balance with those of  $m_2$  and  $m'_2$ . Hence we take  $P = \{(\mathcal{D}, m_0), (\mathcal{D}, m'_0), (\mathcal{D}, m_1), (\mathcal{D}, m'_1), (\mathcal{D}, m_2), (\mathcal{D}, m'_2)\}$ .
- (d) Any marking  $m$  is incompatible with both  $S$  and  $S'$  i.e.

$$\mu_S(\mathcal{D}, m) = \mu_{S'}(\mathcal{D}, m) = 0$$

	$S$	$S'$
$(i, i + 1, i + 2)$	$\frac{[\omega_1][\omega_2][\omega_1 + \omega_2]}{[2]}[\omega_3]^2$	$\frac{[\omega_2][\omega_3][\omega_2 + \omega_3]}{[2]}[\omega_1]^2$
$(i, i + 2, i + 1)$	0	$\frac{[\omega_2][\omega_3][\omega_2 + \omega_3]}{[2]}[\omega_1]^2$
$(i + 1, i, i + 2)$	$\frac{[\omega_1][\omega_2][\omega_1 + \omega_2]}{[2]}[\omega_3]^2$	0
$(i + 1, i + 2, i)$	0	$\frac{[\omega_1][\omega_2][\omega_1 + \omega_2]}{[2]}[\omega_3]^2$
$(i + 2, i, i + 1)$	$\frac{[\omega_2][\omega_3][\omega_2 + \omega_3]}{[2]}[\omega_1]^2$	0
$(i + 2, i + 1, i)$	$\frac{[\omega_2][\omega_3][\omega_2 + \omega_3]}{[2]}[\omega_1]^2$	$\frac{[\omega_1][\omega_2][\omega_1 + \omega_2]}{[2]}[\omega_3]^2$

Table 3.2 – Contribution of the markings in case (b).

and take  $P = \{(\mathcal{D}, m), m \text{ extension of the partial marking}\}$ .

□

We can thus abusively write  $G_g(\Delta, s)$  instead of  $G_g(\Delta, S)$ .

**Definition 3.1.4.** *Let  $\Delta$  be an  $h$ -transverse polygon,  $g \in \mathbb{N}$ ,  $s \in \mathbb{N}$  and  $S$  be any pairing of order  $s$  of  $\{1, \dots, 2s_{\max}(\Delta, g)\}$ . We define*

$$G_g(\Delta, s) = \sum_{(\mathcal{D}, m)} \mu_S(\mathcal{D}, m) \in \mathbb{Z}[q^{\pm 1}]$$

where the sum runs over the isomorphism classes of marked floor diagrams with Newton polygon  $\Delta$  and genus  $g$ . The Laurent polynomial  $G_g(\Delta, s)$  is called Göttsche-Schroeter (refined) invariant of genus  $g$ .

### 3.1.2 Properties of the invariants

In this section we prove few properties satisfied by the higher genus Göttsche-Schroeter invariant. We essentially adapt, when necessary, the proofs given by Brugallé and Jaramillo-Puentes in [BJP22] for the case of genus 0 invariants.

**Proposition 3.1.5.** *Let  $(\mathcal{D}, m)$  be a marked floor diagram of genus  $g$ , and  $S_1 \subset S_2$  be two pairing of the set  $\{1, \dots, n(\mathcal{D})\}$ . Then one has  $\mu_{S_1}(\mathcal{D}, m) - \mu_{S_2}(\mathcal{D}, m) \in \mathbb{N}[q^{\pm 1}]$ .*

**Corollary 3.1.6.** *Let  $\Delta$  be an  $h$ -transverse polygon and  $g \in \mathbb{N}$ . For any  $i \in \mathbb{N}$  one has*

$$\langle G_g(\Delta, 0) \rangle_i \geq \langle G_g(\Delta, 1) \rangle_i \geq \dots \geq \langle G_g(\Delta, s_{\max}(\Delta, g)) \rangle_i.$$

*Proof.* The proofs of [BJP22, proposition 2.16 and corollary 2.17] rely on calculations on quantum integers, and the genus does not play any role. Thus we can copy their proofs.  $\square$

The decrease with respect to  $S$  for  $\mu_S(\mathcal{D}, m)$ , and with respect to  $s$  for  $G_g(\Delta, s)$  can be observed in the examples of section 3.2.1.

**Proposition 3.1.7.** *Let  $\Delta$  be an  $h$ -transverse polygon whose top is depicted in figure 3.5a and  $\tilde{\Delta}$  be the polygon obtained in figure 3.5b by cutting of the top corner of  $\Delta$ . If  $s \leq s_{\max}(\Delta, g)$ , then*

$$G_g(\Delta, s + 1) = G_g(\Delta, s) - 2G_g(\tilde{\Delta}, s).$$



Figure 3.5

*Proof.* The proof is analogous to the one of [BJP22, proposition 2.19].  $\square$

We now extend [BJP22, theorem 1.7] to arbitrary genus.

**Theorem 3.1.8.** *Let  $\Delta$  be an  $h$ -transverse polygon and  $g \leq g_{\max}(\Delta)$ . If  $2i \leq e^{-\infty}(\Delta)$  and  $i \leq g_{\max}(\Delta)$ , then the values  $\langle G_g(\Delta, s) \rangle_i$  for  $0 \leq s \leq s_{\max}(\Delta, g)$  are interpolated by a polynomial of degree  $i$ , whose leading coefficient is  $\frac{(-2)^i}{i!} \binom{g_{\max} - i}{g}$ .*

*Proof.* The beginning of the proof is as in [BJP22, theorem 1.7], hence we will not give the details of the computations before step 2(b) below. Let first introduce few notations.

We denote by  $a_i$  the polynomial of degree at most  $s_{\max} = s_{\max}(\Delta, g)$  which interpolates the values  $(\langle G_g(\Delta, s) \rangle_i)_{0 \leq s \leq s_{\max}}$ . Its  $i$ -th discrete derivative  $a_i^{(i)}$  has degree at most  $s_{\max} - i$ , and we want to show that

$$a_i^{(i)}(0) = \dots = a_i^{(i)}(s_{\max} - i) = 2^i \binom{g_{\max} - i}{g}.$$

Let  $0 \leq s \leq s_{\max} - i$  and  $S$  be a pairing of order  $s$  of  $\{2i + 1, \dots, y(\Delta) - 1 + g\}$ . For  $I \subset \{1, \dots, i\}$  we denote

$$S^I = S \cup \bigcup_{j \in I} \{2j - 1, 2j\}$$

the pairing of order  $s + |I|$  of  $\{1, \dots, y(\Delta) - 1 + g\}$ . Given  $(\mathcal{D}, m)$  a marked floor diagram with Newton polygon  $\Delta$  and genus  $g$  we define

$$\kappa(\mathcal{D}, m) = \sum_{\ell=1}^i \sum_{\substack{I \subset \{1, \dots, i\} \\ |I|=\ell}} (-1)^\ell \mu_{S^I}(\mathcal{D}, m).$$

One has

$$\sum_{j=-g_{\max}+g}^{g_{\max}-g} a_{g_{\max}-g-|j|}^{(i)}(s) q^j = \sum_{(\mathcal{D}, m)} \kappa(\mathcal{D}, m)$$

where the sum runs over the isomorphism classes of marked floor diagrams of Newton polygon  $\Delta$  and genus  $g$ . Hence the diagrams with degree at least  $g_{\max} - g - i$ , i.e. codegree at most  $i$ , contribute to  $a_i^{(i)}$ .

Let  $(\mathcal{D}, m)$  be such a diagram. Denote by  $i_0$  the minimal element of  $\{1, \dots, n(\mathcal{D})\}$  such that  $m^{-1}(i_0) \in V(\mathcal{D})$ , and by  $J \subset \{1, \dots, 2i\}$  the set of elements  $j$  such that  $m^{-1}(j)$  is an elevator in  $E^{-\infty}(\mathcal{D})$  adjacent to  $m^{-1}(i_0)$ .

**Step 1.** If  $J \cup \{i_0\}$  contains a pair  $\{2k - 1, 2k\}$  with  $k \leq i$ , then  $\kappa(\mathcal{D}, m) = 0$ .

We assume from now on that  $J \cup \{i_0\}$  does not contain any pair  $\{2k - 1, 2k\}$  with  $k \leq i$ . In particular,  $|J| \leq i$ .

**Step 2(a).** If  $i_0 \leq 2i$  then  $\kappa(\mathcal{D}, m)$  does not contribute to  $a_i^{(i)}(s)$ .

**Step 2(b).** Suppose now that  $i_0 > 2i$ . In particular,  $m(\{1, \dots, 2i\}) \subset E^{-\infty}(\mathcal{D})$ . Let  $K \subset \{2i + 1, \dots, y(\Delta) - 1 + g\}$  be the set of elements  $k$  such that  $m(k)$  is an elevator in  $E^{-\infty}(\mathcal{D})$  adjacent to  $m(i_0)$ ; one has  $|K| \leq e^{-\infty}(\Delta) - 2i$ . Hence by lemma 2.2.23 one has

$$\text{codeg}(\mathcal{D}) \geq e^{-\infty}(\Delta) - |J| - |K| \geq e^{-\infty}(\Delta) - i - (e^{-\infty}(\Delta) - 2i) = i$$

so  $\mathcal{D}$  can contribute to  $a_i^{(i)}(s)$  if and only if  $\text{codeg}(\mathcal{D}) = i - g$ , which implies  $|J| = i$  and  $|K| = e^{-\infty}(\Delta) - 2i$ . Thus,  $i$  elevators in  $E^{-\infty}(\mathcal{D})$  are not adjacent to  $m(i_0)$  and they are the only elements creating codegree in  $\mathcal{D}$ . Hence,  $\mathcal{D}$  contributes to  $a_i^{(i)}(s)$  if and only if the following set of conditions is satisfied :

- ▷ the order  $\prec$  is total on  $V(\mathcal{D})$ ,
- ▷ elevators in  $E^{+\infty}(\mathcal{D})$  are all adjacent to the top floor,
- ▷  $|J| = i$  and  $J$  contains no pair  $\{2k - 1, 2k\}$ ,



- ▷  $m(\{1, \dots, 2i\} \setminus J)$  consists exactly of elevators in  $E^{-\infty}(\mathcal{D})$  adjacent to the second lowest floor,
- ▷  $E^{-\infty}(\mathcal{D}) \setminus m(\{1, \dots, 2i\})$  consists of elevators adjacent to the lowest floor,
- ▷ the function  $L : V(\mathcal{D}) \rightarrow b_{\text{left}}(\Delta)$  and  $R : V(\mathcal{D}) \rightarrow b_{\text{right}}(\Delta)$  are increasing,
- ▷ any bounded edge is between two consecutive vertices, i.e. the genus is created only by configurations of figure 3.6a ; there is no configuration of figure 3.6b.



Figure 3.6 – Possible configuration for the genus.

The first conditions are those of [BJP22], and the last is added to take into account the genus. These conditions ensure that the marked floor diagrams which contribute to  $a_i^{(i)}(s)$  all satisfy  $\kappa(\mathcal{D}, m) = \mu_S(\mathcal{D}, m)$  and have the shape depicted in figure 3.7, where  $a = a(\Delta)$  is the number of vertices.

There are  $2^i$  possible choices for  $J$ , and given a  $J$  it remains to determine how many marked diagrams of genus  $g$  have a marking that corresponds to  $J$ . Starting with the unique marked diagram  $(\mathcal{D}_0, m_0)$  of genus 0 corresponding to  $J$ , we need to choose a decomposition  $g = g_1 + \dots + g_{a-1}$ , and then split the unique edge between  $v_j$  and  $v_{j+1}$  in  $g_j + 1$  edges. If the weight of the edge is  $w_j$ , then there are  $\binom{w_j-1}{g_j}$  ways to divide the weight and to mark the new edges. Hence the total number of marked diagrams for a given  $J$  is

$$\sum_{\substack{g_1 + \dots + g_{a-1} = g \\ g_j \geq 0, \text{ ordered}}} \prod_{k=1}^{a-1} \binom{w_k - 1}{g_k}$$

which is just

$$\binom{\sum_{k=1}^{a-1} (w_k - 1)}{g} = \binom{\deg(\mathcal{D}_0)}{g} = \binom{g_{\max} - \text{codeg}(\mathcal{D}_0)}{g} = \binom{g_{\max} - i}{g}.$$

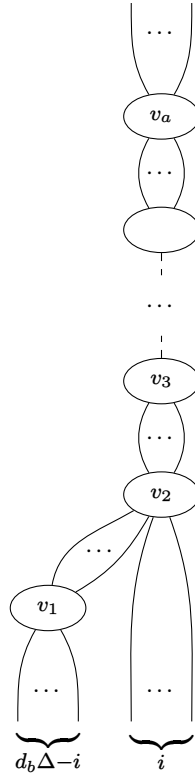

Figure 3.7 – The diagrams that contribute to  $a_i^{(i)}(s)$ .

Hence the total number of marked diagrams is  $2^i \binom{g_{\max} - i}{g}$ . Since the dominant coefficients of the multiplicities are 1 we conclude.  $\square$

## 3.2 Examples and conjectures

### 3.2.1 Some calculations

In this section we run the calculations on some examples. When possible, we use theorem 3.1.8 to compute  $G_g(\Delta, s)$  for few values of  $s$  before interpolating. Otherwise, we compute  $G_g(\Delta, s)$  for  $0 \leq s \leq s_{\max}(\Delta, g)$ . However, in our examples we notice that  $\langle G_g(\Delta, s) \rangle_i$  is always given by a polynomial of degree  $i$  in  $s$ , even when theorem 3.1.8 does not apply. We use tables to present the computations. In a column corresponding to a floor diagram we indicate its contribution to  $G_g(\Delta, s)$ . We put a  $\star$  when this contribution does not change passing from  $s$  to  $s+1$ , to highlight which diagrams contribute to the decrease of  $G_g(\Delta, s)$  with respect so  $s$ , see corollary 3.1.6. Note that for  $g = g_{\max}(\Delta)$  one always has  $G_{g_{\max}(\Delta)}(\Delta, s) = 1$ . Also, because the refined invariants are symmetric we do not precise the coefficients of the negative exponents. In all this section we use the pairing  $S = \{\{1, 2\}, \dots, \{2s - 1, 2s\}\}$ , and recall the trapezoid  $\Delta_{a,b}^n$  of figure 2.3a.









$s$										$G_0(\Delta_{3,2}^0, s)$
0	$[2]^4$	$4[2]^2$	6	$4[2]^2$	6	16	10	10	$q^2 + 12q + 70 + \dots$	
1	*	$2[2]^2$	4	*	*	8	*	4	$q^2 + 10q + 50 + \dots$	
2	$[2]^2[2]_2$	*	2	$4[2]_2$	*	*	*	2	$q^2 + 8q + 34 + \dots$	
3	$([2]_2)^2$	$2[2]_2$	*	*	4	*	4	*	$q^2 + 6q + 22 + \dots$	
4	*	*	*	$2[2]_2$	2	4	2	*	$q^2 + 4q + 14 + \dots$	

Table 3.3 – Computation of  $G_0(\Delta_{3,2}^0, s)$ .

Example 3.2.1. We compute  $G_g(\Delta_{3,2}^0, s)$  for  $0 \leq g \leq 2$ . Tables 3.3 and 3.4 give

$$G_0(\Delta_{3,2}^0, s) = q^2 + (12 - 2s)q + (2s^2 - 22s + 70) + \dots$$

$$G_1(\Delta_{3,2}^0, s) = 2q + (16 - 2s) + \dots$$

$$G_2(\Delta_{3,2}^0, s) = 1.$$

$s$						$G_1(\Delta_{3,2}^0, s)$
0	$[2]^2$	$[2]^2$	4	4	4	$2q + 16 + \dots$
1	*	*	*	2	*	$2q + 14 + \dots$

Table 3.4 – Computation of  $G_1(\Delta_{3,2}^0, s)$ .

$s$							$G_0(\Delta_{2,3}^0, s)$
0	$[3]^2$	$5[2]^2$	10	$5[2]^2$	10	27	$q^2 + 12q + 70 + \dots$
1	*	$3[2]^2$	4	*	*	17	$q^2 + 10q + 50 + \dots$
2	*	$[2]_2$	*	*	*	7	$q^2 + 8q + 34 + \dots$
3	$[3]_2$	*	*	$2[3] + 3[2]_2$	*	5	$q^2 + 6q + 22 + \dots$
4	*	*	*	$2[3] + [2]_2$	4	3	$q^2 + 4q + 14 + \dots$

Table 3.5 – Computation of  $G_0(\Delta_{2,3}^0, s)$ .

$s$				$G_1(\Delta_{2,3}^0, s)$
0	$2[2]^2$	6	6	$2q + 16 + \dots$
1	*	*	4	$2q + 14 + \dots$

Table 3.6 – Computation of  $G_1(\Delta_{2,3}^0, s)$ .

*Example 3.2.2.* We compute  $G_g(\Delta_{2,3}^0, s)$  for  $0 \leq g \leq 2$ . Tables 3.5 and 3.6 give

$$G_0(\Delta_{2,3}^0, s) = q^2 + (12 - 2s)q + (2s^2 - 22s + 70) + \dots$$

$$G_1(\Delta_{2,3}^0, s) = 2q + (16 - 2s) + \dots$$

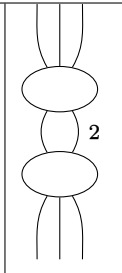
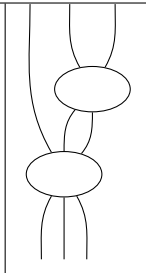
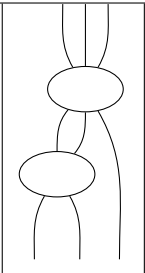
$$G_2(\Delta_{2,3}^0, s) = 1.$$

*Example 3.2.3.* We compute  $G_g(\Delta_{2,2}^1, s)$  for  $0 \leq g \leq 1$ . Tables 3.7 and 3.8 give

$$G_0(\Delta_{2,2}^1, s) = q^2 + (12 - 2s)q + (2s^2 - 22s + 70) + \dots$$

$$G_1(\Delta_{2,2}^1, s) = 2q + (16 - 2s) + \dots$$

$$G_2(\Delta_{2,2}^1, s) = 1.$$



$s$							$G_0(\Delta_{2,2}^1, s)$
0	$[3]^2$	$6[2]^2$	15	$4[2]^2$	6	26	$q^2 + 12q + 70 + \dots$
1	*	$4[2]^2$	7	*	*	18	$q^2 + 10q + 50 + \dots$
2	*	$2[2]_2$	3	*	*	10	$q^2 + 8q + 34 + \dots$

Table 3.7 – Computation of  $G_0(\Delta_{2,2}^1, s)$ .

$s$				$G_1(\Delta_{2,2}^1, s)$
0	$2[2]^2$	5	7	$2q + 16 + \dots$
1	*	*	5	$2q + 14 + \dots$

Table 3.8 – Computation of  $G_1(\Delta_{2,2}^1, s)$ .

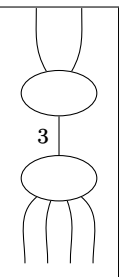
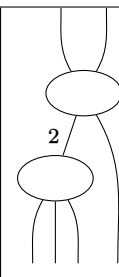
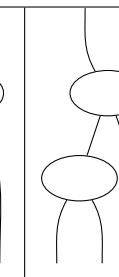
*Example 3.2.4.* Let  $\nabla_{2,2}^1$  be the polygon obtained by applying a  $\frac{\pi}{2}$ -rotation to  $\Delta_{2,2}^1$ . In tables 3.9 and 3.10 the number inscribed in a vertex is its divergence. We obtain

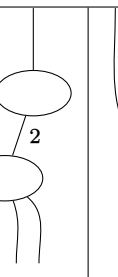
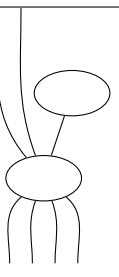
$$G_0(\nabla_{2,2}^1, s) = q^2 + (12 - 2s)q + (2s^2 - 22s + 70) + \dots$$

$$G_1(\nabla_{2,2}^1, s) = 2q + (16 - 2s) + \dots$$

$$G_2(\nabla_{2,2}^1, s) = 1.$$

$s$							$G_1(\nabla_{2,2}^1, s)$
0	$2[2]^2$	$[2]^2$	4	4	1	3	$2q + 16 + \dots$
1	*	*	*	2	*	*	$2q + 14 + \dots$

Table 3.9 – Computation of  $G_1(\nabla_{2,2}^1, s)$ .











$s$											$G_0(\nabla_{2,2}^1, s)$
0	$[2]^4$	$4[2]^2$	6	$[2]^2$	4	1	$3[2]^2$	12	15	10	$q^2 + 12q + 70$
1	*	$2[2]^2$	4	*	2	*	*	6	*	4	$q^2 + 10q + 50$
2	$[2]^2[2]_2$	*	2	$[2]_2$	*	*	$3[2]_2$	*	*	2	$q^2 + 8q + 34$
3	$([2]_2)^2$	$2[2]_2$	*	*	*	*	*	*	7	*	$q^2 + 6q + 22$
4	*	*	*	*	*	*	$[2]_2$	2	3	*	$q^2 + 4q + 14$

Table 3.10 – Computation of  $G_0(\nabla_{2,2}^1, s)$ .

*Example 3.2.5.* We compute  $G_g(\Delta_{2,2}^0, s)$  for  $0 \leq g \leq 1$ . Table 3.11 gives

$$G_0(\Delta_{2,2}^0, s) = q + (10 - 2s) + \dots$$

$$G_1(\Delta_{2,2}^0, s) = 1.$$



$s$				$G_0(\Delta_{2,2}^0, s)$
0	$[2]^2$	4	4	$q + 10 + \dots$
1	*	2	*	$q + 8 + \dots$

Table 3.11 – Computation of  $G_0(\Delta_{2,2}^0, s)$ .

*Example 3.2.6.* We compute  $G_g(\Delta_{2,0}^2, s)$  for  $0 \leq g \leq 1$ . Table 3.12 gives

$$G_0(\Delta_{2,0}^2, s) = q + (8 - 2s) + \dots$$

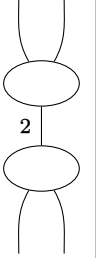
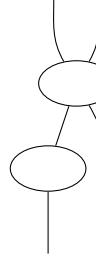
$$G_1(\Delta_{2,0}^2, s) = 1.$$

$s$			$G_0(\Delta_{2,0}^2, s)$
0	$[2]^2$	6	$q + 8 + \dots$
1	*	4	$q + 6 + \dots$
2	*	2	$q + 4 + \dots$
3	$[2]_2$	*	$q + 2 + \dots$

Table 3.12 – Computation of  $G_0(\Delta_{2,0}^2, s)$ .

*Example 3.2.7.* We compute  $G_g(\Delta_{1,2}^2, s)$  for  $0 \leq g \leq 1$ . For  $g = 0 = g_{\max}(\Delta_{1,2}^2)$  there is a unique

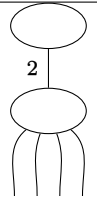
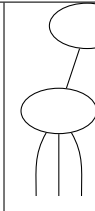

marked floor diagram and it has multiplicity 1. There is no diagram for  $g = 1$ , hence

$$G_0(\Delta_{1,2}^2, s) = 1,$$

$$G_1(\Delta_{1,2}^2, s) = 0.$$

*Example 3.2.8.* We compute  $G_g(\Delta_{2,1}^2, s)$  for  $0 \leq g \leq 2$ . Tables 3.13 and 3.14 give

$$G_0(\Delta_{2,1}^2, s) = q^2 + (12 - 2s)q + (2s^2 - 22s + 67) + \dots$$

$$G_1(\Delta_{2,1}^2, s) = 2q + (16 - 2s) + \dots$$

$$G_2(\Delta_{2,1}^2, s) = 1.$$

$s$						$G_0(\Delta_{2,1}^2, s)$
0	$[3]^2$	$3[2]^2$	$7[2]^2$	21	23	$q^2 + 12q + 67 + \dots$
1	*	*	$5[2]^2$	11	17	$q^2 + 10q + 47 + \dots$
2	*	*	$3[2]^2$	5	11	$q^2 + 8q + 31 + \dots$

Table 3.13 – Computation of  $G_0(\Delta_{2,1}^2, s)$ .

$s$				$G_1(\Delta_{2,1}^2, s)$
0	$2[2]^2$	4	8	$2q + 16 + \dots$
1	*	*	6	$2q + 14 + \dots$

Table 3.14 – Computation of  $G_1(\Delta_{2,1}^2, s)$ .

*Example 3.2.9.* We compute  $G_g(\Delta_{1,3}^2, s)$  for  $0 \leq g \leq 1$ . For  $g = 0 = g_{\max}(\Delta_{1,3}^2)$  there is a unique marked floor diagram and it has multiplicity 1. There is no diagram for  $g = 1$ , hence

$$G_0(\Delta_{1,3}^2, s) = 1,$$

$$G_1(\Delta_{1,3}^2, s) = 0.$$

*Example 3.2.10.* We compute  $G_3(\Delta_{3,3}^0, s)$ . Table 3.15 gives

$$G_3(\Delta_{3,3}^0, s) = 4q + (26 - 2s) + \dots$$

$s$						$G_3(\Delta_{3,3}^0, s)$
0	$2[2]^2$	$2[2]^2$	6	6	6	$4q + 26 + \dots$
1	*	*	4	*	*	$4q + 24 + \dots$

Table 3.15 – Computation of  $G_3(\Delta_{3,3}^0, s)$ .

$s$					$G_3(\Delta_{3,0}^2, s)$
0	$[2]^2$	$3[2]^2$	10	6	$4q + 24 + \dots$
1	*	*	8	*	$4q + 22 + \dots$

Table 3.16 – Computation of  $G_3(\Delta_{3,0}^2, s)$ .

*Example 3.2.11.* We compute  $G_3(\Delta_{3,0}^2, s)$ . Table 3.16 gives

$$G_3(\Delta_{3,0}^2, s) = 4q + (24 - 2s) + \dots$$

*Example 3.2.12.* We compute  $G_3(\Delta_{2,2}^2, s)$ . For  $g = 3 = g_{\max}(\Delta_{2,2}^2)$  there is a unique marked floor diagram and it has multiplicity 1, hence

$$G_3(\Delta_{2,2}^2, s) = 1.$$

*Example 3.2.13.* We compute  $G_3(\Delta_{1,4}^2, s)$ . Since  $g_{\max}(\Delta_{1,4}^2) = 0$ , one has

$$G_3(\Delta_{1,4}^2, s) = 0.$$

*Example 3.2.14.* As a last example, we perform the computation for  $\Delta = \Delta_d$  (see figure 2.2a) and  $g = g_{\max}(\Delta_d) - 1 = \frac{(d-1)(d-2)}{2} - 1$ , with  $d \geq 3$ . We take  $s \leq d/2$  and use the pairing  $S = \{\{1, 2\}, \dots, \{2s-1, 2s\}\}$ . Note that thanks to theorem 3.1.8 we could make the computation only for  $s \leq 1$ . Let  $v_d \prec \dots \prec v_2 \prec v_1$  be the vertices of the unique floor diagram with genus  $g_{\max}(\Delta_d)$ . There are two possible ways to construct a diagram of genus  $g$ .

- ▷ One can merge two bounded edges into an edge of weight 2, see figure 3.8a.
- ▷ One can choose a vertex  $v_i$  for  $2 \leq i \leq d$ , delete an edge below and above  $v_i$ , then add an edge adjacent to  $v_{i-1}$  and  $v_{i+1}$ , see figures 3.8b, 3.8c and 3.8d (in figure 3.8d, one understands  $v_{d+1}$  as a vertex at infinity, hence the added edge is infinite).

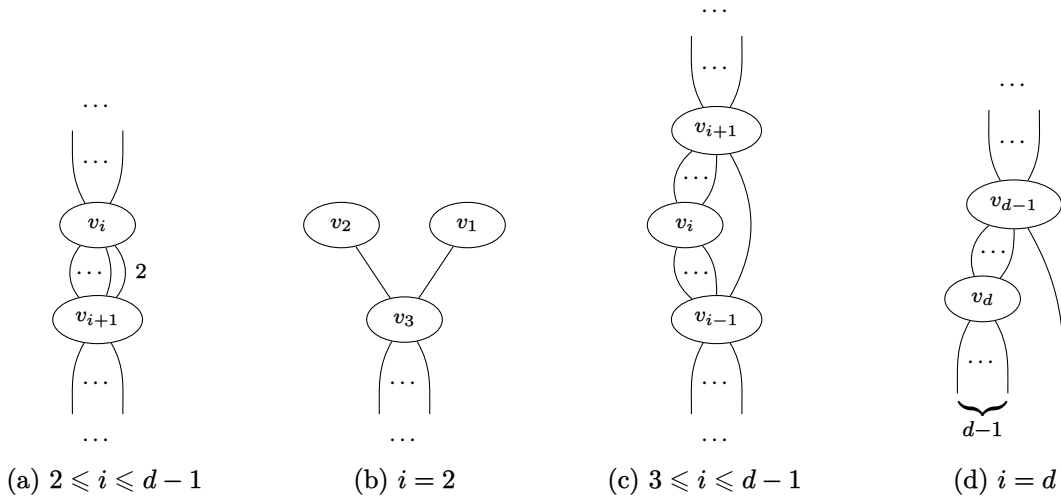

Figure 3.8 – The floor diagrams with Newton polygon  $\Delta_d$  and genus  $g_{\max}(\Delta_d) - 1$ .

In case (a), the  $S$ -multiplicity is  $[2]^2$ . If the bounded edge of weight 2 is adjacent to  $v_i$  and

$v_{i+1}$ , then there are  $i - 1$  markings compatible with  $S$ . One can choose  $2 \leq i \leq d - 1$ , hence the case (a) contributes

$$[2]^2 \sum_{i=2}^{d-1} (i-1) = [2]^2 \frac{(d-1)(d-2)}{2}$$

to  $G_g(\Delta_d, s)$ .

In cases (b), (c) and (d) the  $S$ -multiplicity is 1. In case (b) the number of markings is 3. In case (c) the number of markings is  $2i - 1$ . Last, in case (d) the number of compatible markings is  $2d - 1 - 2s$ . Hence the cases (b), (c) and (d) contribute

$$3 + \sum_{i=3}^{d-1} (2i-1) + 2d - 1 - 2s = d^2 - 1 - 2s$$

to  $G_g(\Delta_d, s)$ .

In the end one has

$$\begin{aligned} G_{g_{\max}(\Delta_d)-1}(\Delta_d, s) &= \frac{(d-1)(d-2)}{2}q + (2d^2 - 3d + 1 - 2s) + \dots \\ &= \binom{g_{\max}(\Delta_d)}{g_{\max}(\Delta_d) - 1} q + (2d^2 - 3d + 1 - 2s) + \dots \end{aligned}$$

In particular, for  $d = 3$  we get  $G_0(\Delta_3, s) = q + (10 - 2s) + q^{-1}$  and we recover example 2.2.21.

### 3.2.2 Observations and conjectures

From the calculations of the previous section 3.2.1, one can make several observations leading to few conjectures.

#### Invariance under lattice preserving transformation

Recall that a lattice preserving transformation is an element of the affine group of  $\mathbb{R}^2$  for which the lattice  $\mathbb{Z}^2$  is invariant. In the previous section, several polygons for which we performed calculations are linked by a lattice preserving transformation. First, examples 3.2.1 and 3.2.2 show that for  $0 \leq g \leq 2$  one has

$$G_g(\Delta_{2,3}^0, s) = G_g(\Delta_{3,2}^0, s).$$

Second, examples 3.2.3 and 3.2.4 show that for  $0 \leq g \leq 2$  one has

$$G_g(\Delta_{2,2}^1, s) = G_g(\nabla_{2,2}^1, s).$$

Although not detailed in this manuscript, one can check for instance that for  $0 \leq g \leq 2$  one also has

$$G_g(\Delta_{2,1}^2, s) = G_g(A\Delta_{2,1}^2, s)$$

where  $A$  is the matrix  $A = \begin{pmatrix} 1 & 0 \\ 1 & 1 \end{pmatrix}$ , and for  $g = 3$  one has

$$G_3(\Delta_{3,0}^2, s) = G_3(A\Delta_{3,0}^2, s).$$

All these observations lead to the following conjecture.

**Conjecture 3.2.15.** *Let  $\Delta$  and  $\Delta'$  be two  $h$ -transverse polygons. If there exists a lattice preserving transformation  $f$  such that  $f(\Delta) = \Delta'$ , then for any  $g \in \{0, \dots, g_{\max}(\Delta)\}$  and  $s \in \{0, \dots, s_{\max}(\Delta, g)\}$  one has*

$$G_g(\Delta, s) = G_g(\Delta', s).$$

We already know the conjecture is true for  $g = 0$ . By the results of chapter 5 this conjecture is asymptotically true in genus 1, if  $\Delta$  and  $\Delta'$  are moreover non-singular and horizontal. Indeed, if the integral lengths of the sides of  $\Delta$  are large enough, we know that the coefficients of small codegree of  $G_1(\Delta, s)$  are given by polynomials which only depend on  $y(\Delta)$ ,  $\chi(\Delta)$  and  $g_{\max}(\Delta)$ , and similarly for  $\Delta'$ . Since the triplet  $(y, \chi, g_{\max})$  is the same for  $\Delta$  and  $\Delta'$ , then the coefficients of small codegrees of  $G_1(\Delta, s)$  and  $G_1(\Delta', s)$  are the same.

### Abramovich-Bertram formula

We already know by Bousseau [Bou21] that Block-Göttsche refined invariants, i.e.  $G_g(\Delta, 0)$ , and genus 0 Göttsche-Schroeter invariants, i.e.  $G_0(\Delta, s)$ , satisfy the Abramovich-Bertram formula. One can wonder if this formula also holds for  $g$  and  $s$  both non-zero. Some examples of the previous section would plea in favor of a positive answer. From examples 3.2.2, 3.2.8 and 3.2.9 we observe that for  $0 \leq g \leq 2$  one has

$$G_g(\Delta_{2,3}^0, s) = G_g(\Delta_{2,1}^2, s) + 3 \times G_g(\Delta_{1,3}^2, s).$$

From examples 3.2.5, 3.2.6 and 3.2.7 we observe that for  $0 \leq g \leq 2$  one has

$$G_g(\Delta_{2,2}^0, s) = G_g(\Delta_{2,0}^2, s) + 2 \times G_g(\Delta_{1,2}^2, s).$$

From examples 3.2.10, 3.2.11, 3.2.12 and 3.2.13 we observe that for  $g = 3$  one has

$$G_3(\Delta_{3,3}^0, s) = G_3(\Delta_{3,0}^2, s) + 2 \times G_3(\Delta_{2,2}^2, s) + 6 \times G_3(\Delta_{1,4}^2, s)$$

and one can check<sup>2</sup> that the previous equality also holds for  $g = 2$  and  $0 \leq s \leq 2$ .

These examples lead to conjecture that the higher genus Göttsche-Schroeter invariants satisfy the Abramovich-Bertram formula.

**Conjecture 3.2.16 (Abramovich-Bertram formula).** *Let  $a, b \in \mathbb{N}$  and  $g \geq 0$ . For any  $s \geq 0$  one has*

$$G_g(\Delta_{a,a+b}^0, s) = \sum_{j=0}^a \binom{b+2j}{j} G_g(\Delta_{a-j,b+2j}^2, s).$$

---

2. The author did it but is not brave enough to write down in this manuscript the 30 diagrams that take part in the calculation.



# Generating series in genus 0

---

This chapter is devoted to the study of tropical refined invariants in genus 0. We will show that the coefficients of small codegree of  $\langle G_0(\Delta, s) \rangle_i$  are given by universal polynomials. Moreover, the generating series of these polynomials is multiplicative in the sense of Göttsche conjecture.

Section 4.1 aims at proving theorems 4.1.10 and 4.1.11. Here we work with refined  $S$ -multiplicities. At the end of the section we show what become the main results if we remove the denominators, i.e. if we consider the asymptotic  $S$ -multiplicities, see section 2.3. Section 4.2 gives another proof of theorem 4.1.5 where we directly work with asymptotic  $S$ -multiplicities. The main interest of this second proof is that it presents methods and objects we will use in chapter 5 when dealing with the genus 1 case.

Sections 4.1 and 4.2.1 are based on the paper [Mév23], while the rest of section 4.2 is based on the paper [BM24]. However, [BM24] only deals with the case  $s = 0$ , i.e. it does not look at Göttsche-Schroeter invariants, as it is done in this text.

## 4.1 Universal series in genus 0

We first set up some notations we will use throughout this section. For any integer vector  $u \in \mathbb{N}^{\mathbb{N}}$  (or  $\mathbb{N}^{\mathbb{N}^*}$ ) with finite support and any  $k \in \mathbb{N}$  we set

$$\text{sum}_k(u) = \sum_{j \geq k} u_j \text{ and } \text{codeg}_k(u) = \sum_{j \geq k} j u_j.$$

We will use the shortcut  $\text{codeg} = \text{codeg}_1$ , and for  $i \geq 1$  let

$$C_i = \{u \in \mathbb{N}^{\mathbb{N}^*} \mid \text{codeg}(u) \leq i\},$$

$$B_i = \{u \in \mathbb{N}^{\mathbb{N}^*} \mid \text{codeg}(u) = i\}.$$

Note that if  $u \in C_i$  or  $u \in B_i$ , then  $u_k = 0$  for  $k \geq i + 1$ . Hence we can consider  $u$  as a vector in  $\mathbb{N}^i$  by forgetting  $u_k$  for  $k \geq i + 1$ . For  $s \in \mathbb{N}$  we denote by  $d(s)$  the set of all decompositions of  $s$ , i.e.

$$d(s) = \{S \in \mathbb{N}^{\mathbb{N}} \mid \text{sum}_0(S) = s\},$$



and for  $S \in d(s)$  we set the multinomial coefficient

$$\binom{s}{S} = \binom{s}{S_0, S_1, \dots} = \frac{s!}{S_0! S_1! \dots}.$$

For integers  $a, p \in \mathbb{N}$  and vectors with finite supports  $u \in \mathbb{N}^{\mathbb{N}^*}$  and  $S \in \mathbb{N}^{\mathbb{N}}$  we define

$$\begin{aligned} \nu_n(a, p, u, S) &= \binom{a + np - \text{sum}_{n+1}(u - 2S)}{u_n - 2S_n}, \\ \nu_{\geq n}(a, p, u, S) &= \prod_{k \geq n} \nu_k(a, p, u, S), \\ \mathcal{N}(a, p, S) &= \sum_{n \geq 0} \left( \sum_{\text{codeg}(u)=n} \nu_{\geq 1}(a, p, u, S) \right) x^n \\ &= \sum_{u \in \mathbb{N}^{\mathbb{N}^*}} \nu_{\geq 1}(a, p, u, S) x^{\text{codeg}(u)}. \end{aligned}$$

Given two integers  $k, \ell \geq 0$  we define

$$F(k, \ell) = \sum_{\substack{i_1 + \dots + i_k = \ell \\ i_j \geq 1}} \prod_{j=1}^k i_j \quad \text{and} \quad \Phi_\ell(k) = F(k, k + \ell)$$

with the convention  $\Phi_0(0) = 1$ . Recall that we consider the following formal series :

$$A(x) = \frac{1}{1-x}, \quad B(x) = \frac{1}{1-x^2}, \quad P(x) = \sum_{n \geq 0} p(n)x^n = \prod_{k \geq 1} \frac{1}{1-x^k},$$

where  $p(n)$  is the number of partitions of  $n$ , and that we denote by  $(P_i(y, \chi, s))_i$  the coefficients of the formal series

$$\sum_{i \geq 0} P_i(y, \chi, s) x^i := A^{y-2-2s} B^s P^\chi.$$

We postpone to section 4.1.5 some lemmas regarding all these quantities, whose proofs are not based on the manipulation of floor diagrams. We will use these lemmas throughout this section.

We start with the case of horizontal and non-singular polygons in section 4.1.1. This case is easier because the fact that the diagrams may have a lot a sources and sinks forces them to have a particular shape. We then relate the refined invariants of a polygon and its blow-up in section 4.1.2, which permits to state a result about invariants of  $\mathbb{C}\mathbb{P}^2$ . This blow-up trick allows then to remove the horizontal hypothesis in section 4.1.3. We last adapt the method of section 4.1.1 and the blow-up trick to singular surfaces in section 4.1.4.

### 4.1.1 Non-singular and horizontal polygons

We first prove the main theorem when the polygon  $\Delta$  is horizontal. Together with the fact we are interested in diagrams of genus 0, it permits an explicit description of the relevant floor diagrams, based on the one given in [BJP22, section 4.1]. While Brugallé and Jaramillo-Puentes only considered Hirzebruch surface there, we enlarge the class of surfaces we look at. The main input is the study of the divergence function of the diagrams. In the Hirzebruch case the divergence is constant, but in general one has to take care of the divergence of floor diagrams with small codegree. This is done in lemmas 4.1.1 and 4.1.4 below.

**Lemma 4.1.1.** *Let  $i \in \mathbb{N}$  and  $\Delta$  be an  $h$ -transverse and non-singular polygon with  $\Delta > 2i$ . Let  $\mathcal{D}$  be a floor diagram with Newton polygon  $\Delta$ , codegree at most  $i$  and having a total order on its vertices  $v_1 \prec \dots \prec v_a$ . Let  $n = \min_k R(v_k)$ ,  $N = \max_k R(v_k)$ , and for  $n \leq k \leq N$  let  $a_k$  be the number of vertices with  $R(v) = k$ . Finally let  $\alpha_k = a_n + \dots + a_k$ .*

- (1) If  $1 \leq j \leq a_n - i$  then  $R(v_j) = n$ .
- (2) If  $n \leq k \leq N - 1$  then :
  - (a) if  $\alpha_k - i + 1 \leq j \leq \alpha_k + i$  then  $R(v_j) \in \{k, k + 1\}$  ; moreover there are  $i$  vertices with  $R(v) = k$  and  $i$  vertices with  $R(v) = k + 1$ ,
  - (b) if  $\alpha_k + i + 1 \leq j \leq \alpha_{k+1} - i$  then  $R(v_j) = k + 1$ .
- (3) If  $\alpha_N - i + 1 \leq j \leq \alpha_N$  then  $R(v_j) = N$ .

The situation described in lemma 4.1.1 is summarized in figure 4.1.

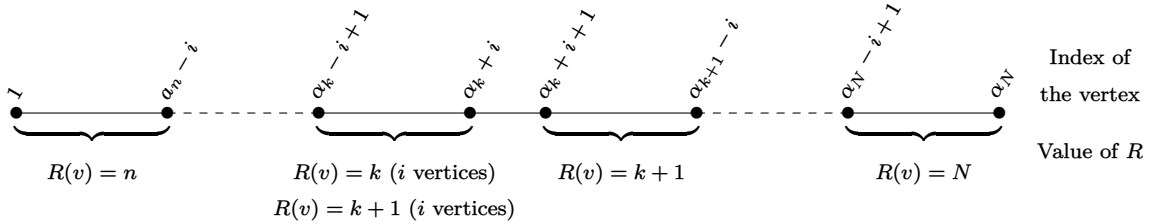

Figure 4.1 – The function  $R$ .

*Proof.* Because  $\Delta$  is non-singular, all its vertices have index 1. Hence the right side of  $\Delta$  looks like the picture of figure 4.2, where we indicate the outward normal vectors of the edges. For any  $n \leq k \leq N$ ,  $a_k$  is the length of the edge of  $\Delta$  having normal vector  $(1, k)$  so  $a_k > 2i$  by hypothesis, which implies  $\alpha_k - i > \alpha_{k-1} + i$  and  $\alpha_k > 2(k - n + 1)i$ . We investigate how we can choose the function  $R$  so that  $\mathcal{D}$  has codegree at most  $i$ . We construct  $R$  from the bottom vertices to the top ones. The key element is lemma 2.2.23.

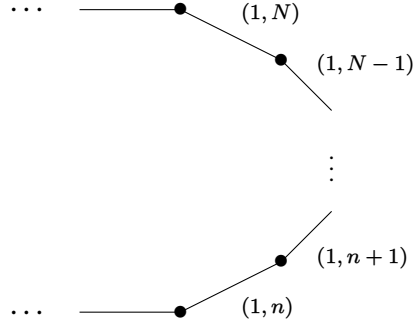

Figure 4.2 – The right side of  $\Delta$ .

- (1) Assume that  $R(v_j) > n$  for some  $1 \leq j \leq a_n - i$ . The vertex  $v_j$  has at least  $a_n - j + 1$  vertices with  $R(v) = n$  above it, thus we can perform at least  $a_n - j + 1$  operations  $B^R$ , each of them making the codegree drop by at most 1 by lemma 2.2.23. Since  $-j \geq i - a_n$  we get  $\text{codeg}(\mathcal{D}) \geq i + 1$ , a contradiction.
- (2) We prove it by induction over  $k$ .

▷ If  $k = n$  then necessarily  $R(v_j) \geq n$  for any  $j$ . Among the  $a_n$  vertices having  $R(v) = n$  we know by (1) that  $a_n - i$  of them are  $v_1, \dots, v_{a_n - i}$ . Thus it remains  $i$  vertices to be given  $R(v) = n$ . If  $R(v_j) = n$  with  $j > a_n + i$  then between  $v_{a_n - i + 1}$  and  $v_{a_n + i}$  there are at most  $i - 1$  vertices having  $R(v) = n$ , so at least  $i + 1$  vertices having  $R(v) > n$ . These  $i + 1$  vertices are all below  $v_j$  thus we can perform at least  $i + 1$  operations  $B^R$  each of them making the codegree drop by at least 1. Hence  $\text{codeg}(\mathcal{D}) > i$ , contradiction. Thus between  $v_{a_n - i + 1}$  and  $v_{a_n + i}$  there are  $i$  vertices with  $R(v) = n$ . Assume that  $R(v_j) > n + 1$  for some  $a_n - i + 1 \leq j \leq a_n + i$ . Then  $v_j$  has at most  $j - a_n + i$  vertices with  $R(v) \in \{n, n + 1\}$  below it, so at least

$$(i + a_{n+1}) - (j - a_n + i) = a_n + a_{n+1} - j \geq a_{n+1} - i > i$$

vertices with  $R(v) \in \{n, n + 1\}$  above it. With some operations  $B^R$  we compute  $\text{codeg}(\mathcal{D}) > i$ , contradiction.

▷ Assume that the result holds up to  $k - 1$  for some  $n \leq k - 1 \leq N - 1$ . All the vertices with  $R(v) \leq k - 1$  have been chosen and are below  $v_{\alpha_{k-1} + i}$ , and  $a_k - i$  vertices with  $R(v) = k$  are between  $v_{\alpha_{k-1} - i + 1}$  and  $v_{\alpha_{k-1} + i}$ . Thus it remains  $i$  vertices with  $R(v) = k$  to choose. If  $R(v_j) = k$  with  $j > \alpha_k + i$ , then between  $v_{\alpha_k - i + 1}$  and  $v_{\alpha_k + i}$  there are at most  $i - 1$  vertices having  $R(v) = k$ , so at least  $i + 1$  vertices having  $R(v) > k$ . These  $i + 1$  vertices are all below  $v_j$  thus we can perform at least  $i + 1$  operations  $B^R$  each of them making the codegree drop by at least 1. Hence  $\text{codeg}(\mathcal{D}) > i$ , contradiction.

Thus between  $v_{\alpha_k-i+1}$  and  $v_{\alpha_k+i}$  there are  $i$  vertices with  $R(v) = k$ . Assume that  $R(v_j) > k+1$  for some  $\alpha_k - i + 1 \leq j \leq \alpha_k + i$ . Then  $v_j$  has at most  $j - \alpha_k + i$  vertices with  $R(v) \in \{k, k+1\}$  below it, so at least

$$(i + a_{k+1}) - (j - \alpha_k + i) = \alpha_k + a_{k+1} - j \geq a_{k+1} - i > i$$

vertices with  $R(v) \in \{k, k+1\}$  above it. With some operations  $B^R$  we compute  $\text{codeg}(\mathcal{D}) > i$ , contradiction.

- (3) The proof is similar to (1). If  $R(v_j) < N$  for some  $\alpha_N - i + 1 \leq j \leq \alpha_N$ , then the vertex  $v_j$  has  $j$  vertices with  $R(v) = N$  below it, thus we can perform  $j$  operations  $B^R$ , each of them making the codegree drop by at most 1 by lemma 2.2.23. Since  $j \geq \alpha_N - i + 1$  and  $\alpha_N \geq a_N > 2i$  we get  $\text{codeg}(\mathcal{D}) \geq i + 1$ , a contradiction.

□

*Remark 4.1.2.* The point (1) is also true if the order is total only on the  $b$  lowest vertices, with some  $b \geq a_n - i$ ; the proof is the same.

*Remark 4.1.3.* Consider  $\Delta'$  the symmetric of  $\Delta$  with respect to a vertical axis. Then any diagram  $\mathcal{D}'$  with Newton polygon  $\Delta'$  corresponds to a unique diagram  $\mathcal{D}$  with Newton polygon  $\Delta$ . Their functions  $R', L'$  and  $R, L$  are linked by  $R' = L$  and  $L' = R$ . Thus, applying lemma 4.1.1 to  $\Delta'$  gives the same result for the function  $L$ .

**Lemma 4.1.4.** *Let  $i \in \mathbb{N}$  and  $\Delta$  be an  $h$ -transverse and non-singular polygon with  $\Delta > 2i$ . The number of possible couples  $(R, L)$  to construct a floor diagram with Newton polygon  $\Delta$ , codegree at most  $i$  and having a total order on its vertices is*

$$\sum_{k=0}^i \sum_{k_1 + \dots + k_{\chi^*(\Delta)-2} = k} p(k_1) \dots p(k_{\chi^*(\Delta)-2})$$

where  $\chi^*(\Delta)$  is the number of non-horizontal edges of  $\Delta$ .

*Proof.* We use the same notations as in lemma 4.1.1.

By lemma 4.1.1, the function  $R$  is entirely described by the data of vectors  $\tilde{\gamma}^k \in (\mathbb{N}^*)^i$  for any  $n \leq k \leq N-1$  such that the vertices between  $v_{\alpha_k-i+1}$  and  $v_{\alpha_k+i}$  having  $R(v) = k$  are the  $v_{\alpha_k-i+\tilde{\gamma}_j^k}$  for  $1 \leq j \leq i$ .

Given  $n \leq k \leq N-1$  and  $1 \leq j \leq i$ , the vertex  $v_{\alpha_k-i+\tilde{\gamma}_j^k}$  has  $\tilde{\gamma}_j^k - j$  vertices with  $R(v) = k+1$  below it, thus we can perform

$$c_R := \sum_{k=n}^{N-1} \sum_{j=1}^i (\tilde{\gamma}_j^k - j)$$

operations  $B^R$ , each of them making the codegree drop by 1. Hence the function  $R$  contributes  $c_R$  to the codegree of  $\mathcal{D}$ .

Similarly, by remark 4.1.3 the function  $L$  is entirely determined by vectors  $\tilde{\delta}^k \in (\mathbb{N}^*)^i$  for any  $n' \leq k \leq N' - 1$ , where  $(-1, n'), (-1, n' + 1), \dots, (-1, N')$  are the primitive outgoing normal vectors of the edges of the left side of  $\Delta$ , from bottom to top. Similarly, we can perform

$$c_L := \sum_{k=n'}^{N'-1} \sum_{j=1}^i (\tilde{\delta}_j^k - j)$$

operations  $B^L$ , each of them making the codegree drop by 1. Hence the function  $L$  contributes  $c_L$  to the codegree of  $\mathcal{D}$ .

Putting together these two contributions we should have

$$c_R + c_L \leq \text{codeg}(\mathcal{D}) \leq i.$$

Given a vector  $\tilde{\beta} \in (\mathbb{N}^*)^i$ , we consider the vector  $\beta \in \mathbb{N}^i$  defined by  $\beta_j = \tilde{\beta}_{i-j+1} - \tilde{\beta}_{i-j} - 1$ , where  $\tilde{\beta}_0 = 0$  by convention. One has

$$\text{codeg}(\beta) = \sum_{j=1}^i (\tilde{\beta}_j - j).$$

Applying this to the vectors  $(\tilde{\gamma}^k)_k$  and  $(\tilde{\delta}^k)_k$ , we see that the data of functions  $R$  and  $L$  satisfying  $c_R + c_L \leq i$  is equivalent to the data of vectors  $(\gamma^k)_k$  and  $(\delta^k)_k$  satisfying

$$\sum_{k=n}^{N-1} \text{codeg}(\gamma^k) + \sum_{k=n'}^{N'-1} \text{codeg}(\delta^k) \leq i,$$

i.e. to the data of  $N + N' - n - n' = \chi^*(\Delta) - 2$  vectors whose sum of codegrees is at most  $i$ . If that sum equals  $k$ , this corresponds to the data of a decomposition  $k_1 + \dots + k_{\chi^*(\Delta)-2} = k$ , and then for any  $1 \leq j \leq \chi^*(\Delta) - 2$  to the data of a vector of codegree  $k_j$ . By lemma 4.1.15 there are  $p(k_j)$  possibilities for such a vector. Hence, we conclude that the number of possible couples  $(R, L)$  is

$$\sum_{k=0}^i \sum_{k_1 + \dots + k_{\chi^*(\Delta)-2} = k} p(k_1) \dots p(k_{\chi^*(\Delta)-2}).$$

□

**Theorem 4.1.5.** *Let  $i \in \mathbb{N}$  and  $\mathcal{F}$  be an  $h$ -transverse, horizontal and non-singular fan. Let*

$\Delta \in D(\mathcal{F})$  and  $s \in \{0, \dots, s_{\max}(\Delta, 0)\}$ . If  $(\Delta, s)$  satisfies

$$\begin{cases} \Delta > 2(i+2) \\ e^{-\infty}(\Delta) \geq i+2s \\ e^{\pm\infty}(\Delta) > i + (a(\Delta) - \lfloor a(\Delta)/2 \rfloor + 1)d_{\mathcal{F}} \end{cases}$$

then

$$\langle G_0(\Delta, s) \rangle_i = P_i(y(\Delta), \chi(\Delta), s).$$

*Proof.* Let  $i, \mathcal{F}, \Delta$  and  $s$  be as in the hypothesis. We look for a formula for  $\langle G_0(\Delta, s) \rangle_i$ . We will use the pairing  $\{\{1, 2\}, \dots, \{2s-1, 2s\}\}$  of order  $s$ . We use the shortcuts  $(a, e^{+\infty}, e^{-\infty}, \chi) = (a(\Delta), e^{+\infty}(\Delta), e^{-\infty}(\Delta), \chi(\Delta))$ .

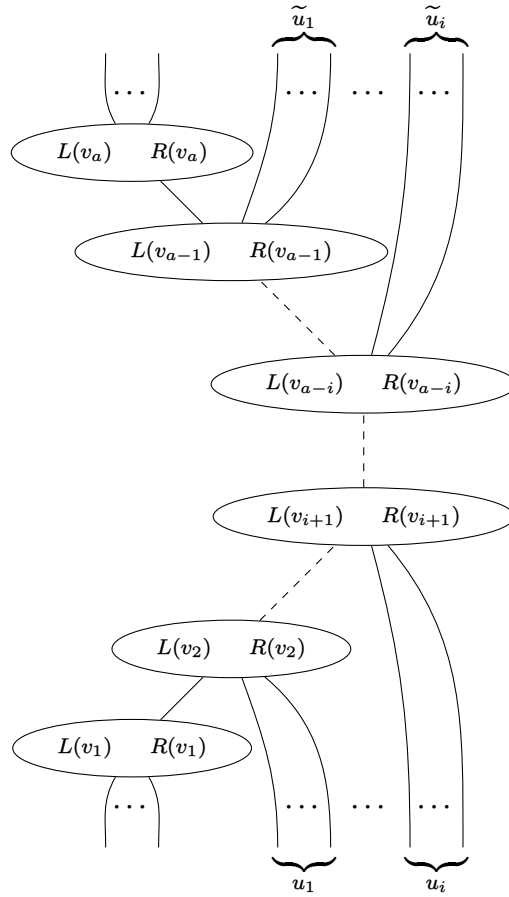

Figure 4.3 – Overall shape for  $\mathcal{D}$ .

By lemma 2.2.26 the order is total on the vertices of any diagram  $\mathcal{D}$  having Newton polygon  $\Delta$ , genus 0 and codegree at most  $i$ ; we denote them by  $v_1 \prec \dots \prec v_a$ . Any such diagram  $\mathcal{D}$  has the shape of figure 4.3 : it can be entirely described by the data of the vectors  $u, \tilde{u} \in \mathbb{N}^i$  and of

the functions  $R, L$ , hence we will use the notation  $\mathcal{D} = (u, \tilde{u}, R, L)$ .

Since  $e^{-\infty} \geq i + 2s$  then for any compatible marking  $m$  and any  $j \leq 2s$  we have  $m^{-1}(j) \in E^{-\infty}(\mathcal{D})$ . In particular, the multiplicity of  $(\mathcal{D}, m)$  does not depend on  $m$  and is just

$$\mu_{\text{BG}}(\mathcal{D}) = \prod_{e \in E_0} [w(e)]^2.$$

We then have

$$\langle G_0(\Delta, s) \rangle_i = \sum_{\mathcal{D}} \nu(\mathcal{D}) \langle \mu_{\text{BG}}(\mathcal{D}) \rangle_{i - \text{codeg}(\mathcal{D})}$$

where the sum runs over the floor diagrams of Newton polygon  $\Delta$ , genus 0 and codegree at most  $i$ , and where  $\nu(\mathcal{D})$  is the number of markings of  $\mathcal{D}$  compatible with  $S$ . For  $\mathcal{D} = (u, \tilde{u}, R, L)$  this number only depends on  $u$  and  $\tilde{u}$  and is

$$\nu(\mathcal{D}) = \sum_{S \in d(s)} \binom{s}{S} \nu_{\geq 1}(e^{-\infty}, 2, u, S) \nu_{\geq 1}(e^{+\infty}, 2, \tilde{u}, 0).$$

By lemma 2.2.29 and lemma 4.1.19 its multiplicity gives

$$\langle \mu_{\text{BG}}(\mathcal{D}) \rangle_{i - \text{codeg}(\mathcal{D})} = \Phi_{i - \text{codeg}(\mathcal{D})}(a - 1)$$

which is also independent of  $R$  and  $L$ . Thus, to compute  $\langle G_0(\Delta, s) \rangle_i$  we need to determine how many couples  $(R, L)$  are possible and then sum over  $(u, \tilde{u})$ . Here,  $\chi^*(\Delta) = \chi - 2$  so by lemma 4.1.4 the number of possible couples  $(R, L)$  is

$$\sum_{k=0}^i \sum_{k_1 + \dots + k_{\chi-4} = k} p(k_1) \dots p(k_{\chi-4}).$$

Once  $(R, L)$  is chosen and contributes  $k$  to the codegree, it remains to sum over  $(u, \tilde{u})$  such that  $\text{codeg}(u + \tilde{u}) \leq i - k$ , i.e.  $u + \tilde{u} \in C_{i-k}$ . We can now compute

$$\begin{aligned} \langle G_0(\Delta, s) \rangle_i &= \sum_{\mathcal{D}} \nu(\mathcal{D}) \langle \mu_{\text{BG}}(\mathcal{D}) \rangle_{i - \text{codeg}(\mathcal{D})} \\ &= \sum_{k=0}^i \sum_{k_1 + \dots + k_{\chi-4} = k} p(k_1) \dots p(k_{\chi-4}) \sum_{u + \tilde{u} \in C_{i-k}} \nu(\mathcal{D}) \Phi_{i-k - \text{codeg}(u + \tilde{u})}(a - 1) \\ &= \sum_{k=0}^i \sum_{k_1 + \dots + k_{\chi-4} = k} p(k_1) \dots p(k_{\chi-4}) \sum_{j=1}^{i-k} \sum_{u + \tilde{u} \in B_j} \nu(\mathcal{D}) \Phi_{i-k-j}(a - 1) \end{aligned}$$

which shows that  $\langle G_0(\Delta, s) \rangle_i$  coincides with the degree  $i$  coefficient of the product of :

- ▷ the generating series of  $\left( \sum_{k_1+\dots+k_{\chi-4}=k} p(k_1)\dots p(k_{\chi-4}) \right)_k$ , which is  $P^{\chi-4}$  by definition,
- ▷ the generating series of  $\left( \sum_{u+\tilde{u}\in B_k} \nu(\mathcal{D}) \right)_k$ , which is  $B^s A^{e^{-\infty}+e^{+\infty}-2s} P^4$  by lemma 4.1.16,
- ▷ the generating series of  $(\Phi_k(a-1))_k$ , which is  $A^{2a-2}$  by lemma 4.1.18.

Since  $y = e^{-\infty} + e^{+\infty} + 2a$ , this product is

$$A^{y-2-2s} B^s P^\chi$$

and its degree  $i$  coefficient is the polynomial  $P_i$  by definition. □

### 4.1.2 The blow-up trick and the case of $\mathbb{CP}^2$

Let  $\mathcal{F}$  be a fan. Let  $u$  and  $v$  be two primitive generators of two consecutive rays of  $\mathcal{F}$ . Consider  $\tilde{\mathcal{F}}$  be the fan constructed from  $\mathcal{F}$  by adding a ray generated by  $u+v$ . We say that  $\tilde{\mathcal{F}}$  is a *blow-up* of  $\mathcal{F}$ . This terminology comes from toric geometry : the surface  $X_{\tilde{\mathcal{F}}}$  is the blow-up of  $X_{\mathcal{F}}$  at one point. At the level of the dual polygons, any  $\tilde{\Delta} \in D(\tilde{\mathcal{F}})$  is obtained by cutting off a corner of a  $\Delta \in D(\mathcal{F})$ , and is said to be a blow-up of  $\Delta$ . Note that to determine  $\tilde{\Delta}$  we need to choose the integral length of the side we add to  $\Delta$ .

In this subsection we determine how do the coefficients of small codegrees of tropical refined invariant change when blowing-up a polygon. The main result is proposition 4.1.6 which establishes a link between  $\langle G_0(\Delta, s) \rangle_i$  and  $\langle G_0(\tilde{\Delta}, s) \rangle_i$ . This relation allows us to determine in corollary 4.1.8 a formula for the coefficients of small codegree of the tropical refined invariant associated to the surface  $\mathbb{CP}^2$ , which was not included in the range of surfaces handled in theorem 4.1.5.

Let  $i \in \mathbb{N}$ . For  $\Delta$  a polygon with dual fan  $\mathcal{F}$  and  $s$  an integer we consider the following conditions :

$$(\star)_i \begin{cases} \Delta > 2(i+2) \\ e^{-\infty}(\Delta) \geq i+2s \\ e^{-\infty}(\Delta) > i + (a(\Delta) - \lfloor a(\Delta)/2 \rfloor + 1)d_{\mathcal{F}} \end{cases} .$$

**Proposition 4.1.6.** *Let  $\Delta$  be an  $h$ -transverse and non-singular polygon, and  $\tilde{\Delta}$  be a blow-up at the bottom right corner. We depict their bottom right corners in figure 4.4. There exists a series  $C$  such that if  $(\Delta, s)$  and  $(\tilde{\Delta}, s)$  both satisfy  $(\star)_i$  then  $\langle G_0(\Delta, s) \rangle_i$  is given by the degree  $i$  coefficient of*

$$A^{e^{-\infty}(\Delta)-2s} B^s P^2 \times C,$$



and  $\langle G_0(\tilde{\Delta}, s) \rangle_i$  is given by the degree  $i$  coefficient of

$$A e^{-\infty(\tilde{\Delta})-2s} B^s P^3 \times C.$$

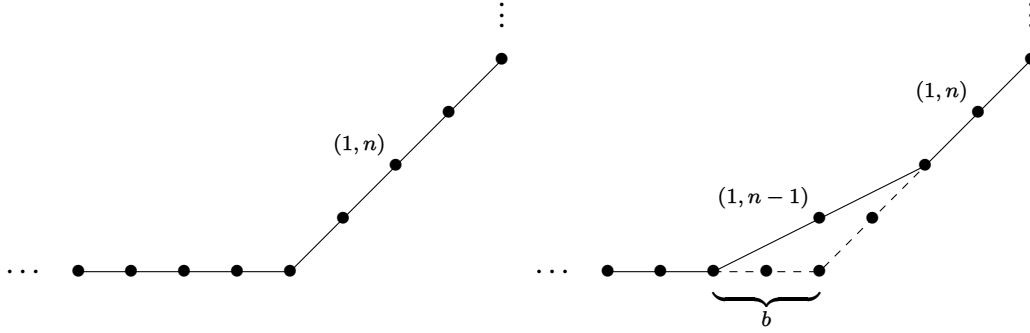

Figure 4.4 – The polygons  $\Delta$  (left) and  $\tilde{\Delta}$  (right).

*Proof.* Let  $a = a(\Delta) = a(\tilde{\Delta})$  and  $e^{-\infty} = e^{-\infty}(\Delta)$ . We denote by  $a_n$  the integer length of the edge of the right side of  $\Delta$  having outgoing normal vector  $(1, n)$ . We denote by  $b$  the integer length we cut off from the sides of  $\Delta$  to obtain  $\tilde{\Delta}$ , see figure 4.4. We will use the pairing  $\{\{1, 2\}, \dots, \{2s - 1, 2s\}\}$  of order  $s$ .

We will first make a calculation for  $\Delta$ . Then we will explain how to construct a correspondence between the floor diagrams of genus 0 with Newton polygon  $\Delta$  and the ones with Newton polygon  $\tilde{\Delta}$ , allowing us to make a calculation for  $\tilde{\Delta}$ .

**Calculation for  $\Delta$ .** Because  $\Delta$  is large enough, any diagram  $\mathcal{D}$  that contributes to  $\langle G_0(\Delta, s) \rangle_i$  has a unique minimal vertex by lemma 2.2.26. By lemma 2.2.28,  $\mathcal{D}$  has a total order on its  $a - i - 1$  lowest vertices. It may have several maximal vertices that we hide in a very top part  $\mathcal{T}$ , see figure 4.5. By remark 4.1.2, the function  $R$  is constant on the  $a_n - i$  lowest vertices. Moreover, we have the following inequalities :

$$i + 1 < b + i < \left\lfloor \frac{a + b}{2} \right\rfloor < a - i - 1.$$

We can cut  $\mathcal{D}$  into two parts, see figure 4.5 :

- ▷ a bottom part : we denote by  $\mathcal{D}^-$  the diagram consisting of the sources, the vertices from  $v_1$  to  $v_{\lfloor (a+b)/2 \rfloor}$  and the bounded edges between them ;
- ▷ a top part : we denote by  $\mathcal{D}^+$  the remaining of  $\mathcal{D}$  ; it has  $a - \lfloor (a + b)/2 \rfloor$  vertices.

This leads to consider the following sets. Let  $k \in \{0, \dots, i\}$ . We define

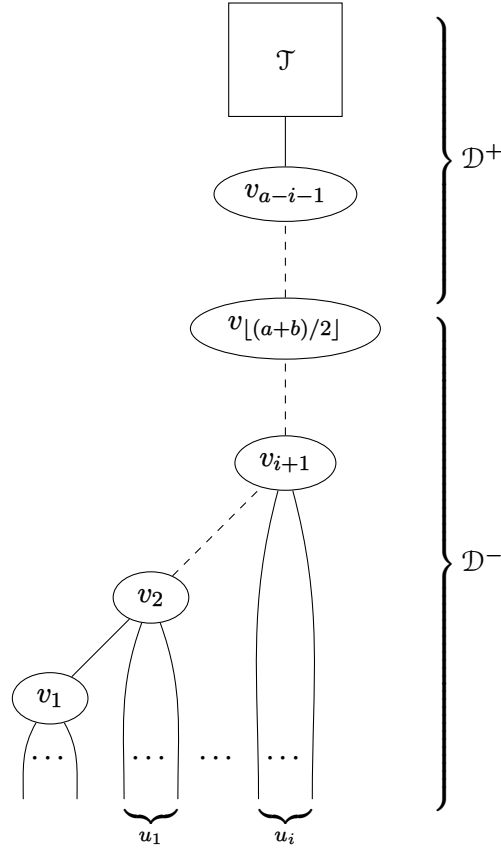

Figure 4.5 – Decomposition of a diagram.

- ▷  $B_k(\Delta)$  the set of all possible bottom parts  $\mathcal{D}^-$  having  $\lfloor (a+b)/2 \rfloor$  vertices and of codegree  $k$ . Encoding how the sources are attached to the vertices we establish a bijection between  $B_k(\Delta)$  and  $B_k$  : each  $\mathcal{D}^-$  can be represented by a  $u \in B_k$ .
- ▷  $T_{i-k}(\Delta)$  the set of all possible top parts  $\mathcal{D}^+$  having  $a - \lfloor (a+b)/2 \rfloor$  vertices and of codegree at most  $i - k$ .

As explained above, if  $C_i(\Delta)$  is the set of floor diagrams of Newton polygon  $\Delta$ , genus 0 and codegree at most  $i$  then there is a bijection

$$C_i(\Delta) \simeq \bigsqcup_{k=0}^i B_k \times T_{i-k}(\Delta).$$

The number of markings of a diagram  $\mathcal{D}$  can be calculated separately on its top and bottom parts. If  $\mathcal{D}$  is represented by  $(u, \mathcal{D}^+) \in B_k \times T_{i-k}(\Delta)$ , we denote by  $\nu(\mathcal{D}^+)$  the number of

markings of the top part  $\mathcal{D}^+$ , and the number of markings of the bottom part is

$$\sum_{S \in d(s)} \binom{s}{S} \nu_{\geq 1}(e^{-\infty} - 2s, 2, u, S).$$

Moreover, because  $e^{-\infty} \geq i + 2s$  then for any compatible marking  $m$  and any  $j \leq 2s$  one has  $m^{-1}(j) \in E^{-\infty}(\mathcal{D})$ . Hence the multiplicity of  $(\mathcal{D}, m)$  does not depend on  $m$  and is

$$\begin{aligned} \mu_{\text{BG}}(u, \mathcal{D}^+) &= \mu_{\text{BG}}(\mathcal{D}) = \prod_{e \in E_0} [w(e)]^2 \\ &= \prod_{e \in E_0 \cap E(\mathcal{D}^-)} [w(e)]^2 \times \prod_{e \in E_0 \cap E(\mathcal{D}^+)} [w(e)]^2 \\ &= \mu_{\text{BG}}(\mathcal{D}^-) \times \mu_{\text{BG}}(\mathcal{D}^+). \end{aligned}$$

By lemmas 2.2.29 and 4.1.19 it gives

$$\begin{aligned} \langle \mu_{\text{BG}}(\mathcal{D}) \rangle_{i-k-\text{codeg}(\mathcal{D}^+)} &= \sum_{i_1+i_2=i-k-\text{codeg}(\mathcal{D}^+)} \langle \mu_{\text{BG}}(\mathcal{D}^+) \rangle_{i_1} \langle \mu_{\text{BG}}(\mathcal{D}^-) \rangle_{i_2} \\ &= \sum_{i_1+i_2=i-k-\text{codeg}(\mathcal{D}^+)} \langle \mu_{\text{BG}}(\mathcal{D}^+) \rangle_{i_1} \Phi_{i_2}(\lfloor (a+b)/2 \rfloor - 1) \end{aligned}$$

and this is independent of  $u$ . Hence if we set

$$\begin{aligned} \alpha_k(e^{-\infty}, s) &= \sum_{u \in B_k} \sum_{S \in d(s)} \binom{s}{S} \nu_{\geq 1}(e^{-\infty} - 2s, u, 2, S), \\ \beta_k(a, b) &= \sum_{\mathcal{D}^+ \in T_k(\Delta)} \nu(\mathcal{D}^+) \sum_{i_1+i_2=k-\text{codeg}(\mathcal{D}^+)} \langle \mu_{\text{BG}}(\mathcal{D}^+) \rangle_{i_1} \Phi_{i_2}(\lfloor (a+b)/2 \rfloor - 1), \end{aligned}$$

then we get

$$\begin{aligned} \langle G_{\Delta}(0; s) \rangle_i &= \sum_{\text{codeg}(\mathcal{D}) \leq i} \nu(\mathcal{D}) \langle \mu_{\text{BG}}(\mathcal{D}) \rangle_{i-\text{codeg}(\mathcal{D})} \\ &= \sum_{k=0}^i \sum_{u \in B_k} \sum_{S \in d(s)} \binom{s}{S} \nu_{\geq 1}(e^{-\infty} - 2s, u, 2, S) \sum_{\mathcal{D}^+ \in T_{i-k}(\Delta)} \nu(\mathcal{D}^+) \langle \mu_{\text{BG}}(u, \mathcal{D}^+) \rangle_{i-k-\text{codeg}(\mathcal{D}^+)} \\ &= \sum_{k=0}^i \alpha_k(e^{-\infty}, s) \beta_{i-k}(a, b) \end{aligned}$$

which shows that  $\langle G_{\Delta}(0; s) \rangle_i$  is the degree  $i$  coefficient of the product of

- ▷ the generating series of  $(\alpha_k(e^{-\infty}, s))_k$  which is  $A^{e^{-\infty}-2s} B^s P^2$  by lemma 4.1.16,
- ▷ the generating series of  $(\beta_k(a, b))_k$  that we will denote by  $C$ .

**Calculation for  $\tilde{\Delta}$ .** Now let's have a look at what happens for  $\tilde{\Delta}$ . Let  $k \in \{0, \dots, i\}$  and  $j \in \{0, \dots, i - k\}$  be integers, let  $\gamma \in B_k$  be a vector of codegree  $k$ , and let  $\mathcal{D} = (u, \mathcal{D}^+) \in B_j \times T_{i-k-j}(\Delta)$  be a diagram with Newton polygon  $\Delta$ , genus 0 and codegree at most  $i - k$ . Because  $b > 2(i + 2)$  we can see  $\gamma$  as a vector in  $\mathbb{N}^b$ . Consider  $\tilde{\gamma} \in \mathbb{N}^b$  the vector given by

$$\tilde{\gamma}_m = \sum_{\ell=0}^{m-1} (\gamma_{b-\ell} + 1), \quad \text{i.e. } \gamma_m = \tilde{\gamma}_{b-m+1} - \tilde{\gamma}_{b-m} - 1$$

with the convention  $\tilde{\gamma}_0 = 0$ . Note that we have  $\tilde{\gamma}_1 \geq 1$ ,  $\tilde{\gamma}_m > \tilde{\gamma}_{m-1}$  and

$$\text{codeg}(\gamma) = \sum_{m=1}^b (\tilde{\gamma}_m - m).$$

In particular,  $\tilde{\gamma}_m \leq b + i$  otherwise we would have  $\text{codeg}(\gamma) > k$ . This implies  $\tilde{\gamma}_m \leq a_n - i$  and so  $R(v_{\tilde{\gamma}_m}) = n$  by lemma 4.1.1.

Consider the diagram  $\mathcal{D}_\gamma$  obtained from  $\mathcal{D}$  with the following process : set  $R(v_{\tilde{\gamma}_m}) = n - 1$  for any  $1 \leq m \leq b$ , adjust the weight of the bounded edges and remove enough sources to the minimal vertex of  $\mathcal{D}$  to satisfy the divergence condition. Then  $\mathcal{D}_\gamma \in C_i(\tilde{\Delta})$  ; its codegree is  $\text{codeg}(\mathcal{D}_\gamma) = \text{codeg}(\mathcal{D}) + \text{codeg}(\gamma) \leq i$ . Note that we did not change anything in the top part  $\mathcal{D}^+$  of  $\mathcal{D}$ .

Conversely let  $\tilde{\mathcal{D}} \in C_i(\tilde{\Delta})$ . By lemmas 2.2.26 and 2.2.28,  $\tilde{\mathcal{D}}$  admits a total order on its  $a - i - 1$  lowest vertices. The diagram  $\tilde{\mathcal{D}}$  has  $b$  vertices with  $R(v) = n - 1$ . Suppose there is such a vertex with more than  $b + i$  vertices below it. Then at least  $i + 1$  of the vertices below it have  $R(v) = n$ . Performing  $i + 1$  operations  $B^R$  we see that  $\text{codeg}(\tilde{\mathcal{D}}) \geq i + 1$ , a contradiction. Thus all the vertices with  $R(v) = n - 1$  are between  $v_1$  and  $v_{b+i}$ . We denote by  $\tilde{\gamma} \in \mathbb{N}^b$  the vector whose coordinates are the indices of the vertices with  $R(v) = n - 1$ , and let  $\gamma \in \mathbb{N}^b$  be defined by  $\gamma_m = \tilde{\gamma}_{b-m+1} - \tilde{\gamma}_{b-m} - 1$ . Then

$$k := \text{codeg}(\gamma) = \sum_{m=1}^b (\tilde{\gamma}_m - m) \leq \text{codeg}(\tilde{\mathcal{D}}) \leq i$$

and  $\tilde{\mathcal{D}} = \mathcal{D}_\gamma$ , where  $\mathcal{D}$  is the diagram of  $C_{i-k}(\Delta)$  obtained by setting  $R(v_{\tilde{\gamma}_m}) = n$  for any  $1 \leq m \leq b$ , then adjusting the weights and adding enough sources to  $v_1$ .

In other words, there is a bijection

$$C_i(\tilde{\Delta}) \simeq \bigsqcup_{k=0}^i B_k \times C_{i-k}(\Delta)$$

and a floor diagram with Newton polygon  $\tilde{\Delta}$ , genus 0 and codegree at most  $i$  can be represented

as

$$\tilde{\mathcal{D}} = \mathcal{D}_\gamma = (\gamma, \mathcal{D}) \in B_k \times C_{i-k}(\Delta)$$

for some  $1 \leq k \leq i$ . Its codegree is

$$\text{codeg}(\tilde{\mathcal{D}}) = \text{codeg}(\gamma) + \text{codeg}(\mathcal{D}) = k + \text{codeg}(\mathcal{D})$$

The diagram  $\mathcal{D}$  is itself represented by

$$\mathcal{D} = (u, \mathcal{D}^+) \in B_j \times T_{i-k-j}(\Delta)$$

for some  $1 \leq j \leq i - k$ , so

$$\tilde{\mathcal{D}} = (\gamma, u, \mathcal{D}^+) \in B_k \times B_j \times T_{i-k-j}(\Delta).$$

The number of markings can be computed separately on a bottom part  $\tilde{\mathcal{D}}^- = (\gamma, u)$  and on a top part  $\tilde{\mathcal{D}}^+ = \mathcal{D}^+$ . Moreover, by lemma 2.2.29 all the edges of  $\tilde{\mathcal{D}}^-$  have a weight greater than  $i - \text{codeg}(\tilde{\mathcal{D}})$  so that in the expression

$$\begin{aligned} \langle G_{\tilde{\Delta}}(0; s) \rangle_i &= \sum_{k=0}^i \sum_{\gamma \in B_k} \sum_{j=0}^{i-k} \sum_{u \in B_j} \sum_{S \in d(s)} \binom{s}{S} \nu_{\geq 1}(e^{-\infty} - b - 2s, 2, u, S) \\ &\quad \sum_{\mathcal{D}^+ \in T_{i-k-j}(\Delta)} \nu(\mathcal{D}^+) \langle \mu(\gamma, u, \mathcal{D}^+) \rangle_{i-k-j-\text{codeg}(\mathcal{D}^+)} \end{aligned}$$

the inner sum does not depend neither on  $u$  nor on  $\gamma$  by lemma 4.1.19. Hence, the sum over  $\gamma \in B_k$  contributes  $p(k)$  by lemma 4.1.15, and we get

$$\langle G_{\tilde{\Delta}}(0; s) \rangle_i = \sum_{k=0}^i p(k) \sum_{j=0}^{i-k} \alpha_j(e^{-\infty} - b, s) \beta_{i-k-j}(a, b)$$

which shows that  $\langle G_{\tilde{\Delta}}(0; s) \rangle_i$  is the degree  $i$  coefficient of the product of

- ▷ the generating series of  $(p(k))_k$  which is  $P$  by definition,
- ▷ the generating series of  $(\alpha_k(e^{-\infty} - b, s))_k$  which is  $A^{e^{-\infty} - b - 2s} B^s P^2$  by lemma 4.1.16,
- ▷ the generating series of  $(\beta_k(a, b))_k$  which is  $C$ .

Since  $e^{-\infty}(\tilde{\Delta}) = e^{-\infty} - b$  we can conclude. □

**Corollary 4.1.7.** *With the same notations as in proposition 4.1.6, let  $i_m$  be an integer such that both  $(\Delta, s)$  and  $(\tilde{\Delta}, s)$  satisfy  $(\star)_{i_m}$ . The following are equivalent.*

(1) For any  $i \in \{0, \dots, i_m\}$ ,  $\langle G_0(\Delta, s) \rangle_i = P_i(y(\Delta), \chi(\Delta), s)$ ,

(2) For any  $i \in \{0, \dots, i_m\}$ ,  $\langle G_0(\tilde{\Delta}, s) \rangle_i = P_i(y(\tilde{\Delta}), \chi(\tilde{\Delta}), s)$ .

*Proof.* For any  $0 \leq i \leq i_m$ , both  $(\Delta, s)$  and  $(\tilde{\Delta}, s)$  satisfy  $(\star)_i$ . Hence by definition of  $(P_i)_i$  and proposition 4.1.6 one has the following equivalences :

$$\begin{aligned} (1) &\Leftrightarrow A^{e^{-\infty}(\Delta)-2s} B^s P^2 \times C = A^{y(\Delta)-2-2s} B^s P^{\chi(\Delta)} \pmod{x^{i_m}} \\ &\Leftrightarrow A^{e^{-\infty}(\tilde{\Delta})+b-2s} B^s P^3 \times C = A^{y(\tilde{\Delta})+b-2-2s} B^s P^{\chi(\tilde{\Delta})+1} \pmod{x^{i_m}} \\ &\Leftrightarrow A^{e^{-\infty}(\tilde{\Delta})-2s} B^s P^3 \times C = A^{y(\tilde{\Delta})-2-2s} B^s P^{\chi(\tilde{\Delta})} \pmod{x^{i_m}} \\ &\Leftrightarrow (2). \end{aligned}$$

□

This can be used to compute  $\langle G_0(\Delta, s) \rangle_i$  when the underlying toric surface is  $\mathbb{CP}^2$ .

**Corollary 4.1.8.** Let  $\mathcal{F}$  be the fan whose rays are generated by  $(-1, 0)$ ,  $(0, -1)$  and  $(1, 1)$ . For any  $i \in \mathbb{N}$ , any  $\Delta \in D(\mathcal{F})$  and  $s \in \{0, \dots, s_{\max}(\Delta, 0)\}$ , if

$$\begin{cases} \Delta > 5(i+1) + 6 \\ \Delta > i + 2s \end{cases}$$

then one has

$$\langle G_0(\Delta, s) \rangle_i = P_i(y(\Delta), 3, s).$$

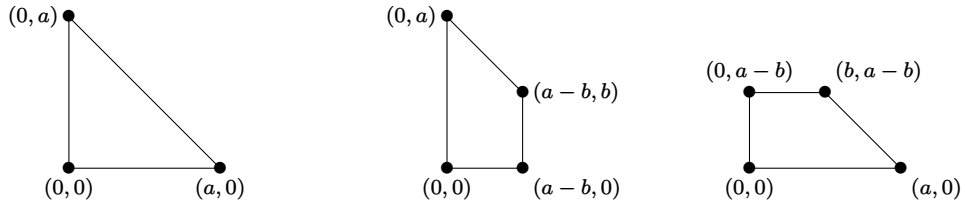

Figure 4.6 – The polygons  $\Delta_a$  (left) and  $\Delta_{a,b}$  (middle) and  $\Delta'_{a,b} = \Delta_{b,a-b}^1$  (right).

*Proof.* A polygon  $\Delta \in D(\mathcal{F})$  is a  $\Delta_a$  for some  $a \in \mathbb{N}^*$ , see figure 4.6. Let  $i_m$  be the maximal integer such that

$$\begin{cases} \Delta > 5(i_m + 1) + 6 \\ \Delta > i_m + 2s \end{cases}$$

and  $b$  be an integer such that

$$\frac{a + 2(i_m + 1) + 1}{5} < b < \frac{a - 2(i_m + 1) - 1}{2}.$$

We consider the polygon  $\Delta_{a,b}$  of figure 4.6. The hypotheses imply that for any  $i \in \{1, \dots, i_m\}$  one has

$$\begin{cases} a, b, a - b > 2(i + 2) \\ a, a - b > i + 2s \\ a, a - b > i + a - \left\lfloor \frac{a}{2} \right\rfloor + 1 \end{cases}$$

so  $\Delta_a$  and  $\Delta_{a,b}$  both satisfy the condition  $(\star)_i$  and we can apply corollary 4.1.7 with  $\Delta = \Delta_a$  and  $\tilde{\Delta} = \Delta_{a,b}$ . We will check that the assertion (2) of corollary 4.1.7 is true, and deduce that (1) also holds.

The polygon  $\Delta_{a,b}$  is congruent to  $\Delta'_{a,b}$ , see figure 4.6, so that  $G_0(\Delta_{a,b}, s) = G_0(\Delta'_{a,b}, s)$ . Note also that  $y(\Delta_{a,b}) = y(\Delta'_{a,b})$  and  $\chi(\Delta_{a,b}) = \chi(\Delta'_{a,b}) = 4$ . The hypotheses imply that for any  $i \in \{1, \dots, i_m\}$  one has

$$\begin{cases} a, b, a - b > 2(i + 2) \\ a > i + 2s \\ a, b > i + a - b - \left\lfloor \frac{a+b}{2} \right\rfloor + 1 \end{cases}$$

hence by theorem 4.1.5 applied to  $\Delta'_{a,b}$  one has

$$\langle G_0(\Delta'_{a,b}, s) \rangle_i = P_i(y(\Delta'_{a,b}), \chi(\Delta'_{a,b}), s) = P_i(y(\Delta'_{a,b}), 4, s)$$

and so  $\langle G_{\Delta_{a,b}}(0; s) \rangle_i = P_i(y(\Delta_{a,b}), 4, s)$  for any  $i \in \{1, \dots, i_m\}$ . Hence the point (2) of corollary 4.1.7 is true and we deduce that (1) also holds. In particular, one has

$$\langle G_0(\Delta_a, s) \rangle_i = P_i(y(\Delta_a), \chi(\Delta), s) = P_i(y(\Delta_a), 3, s)$$

for any  $i \in \{0, \dots, i_m\}$ . □

### 4.1.3 The non-singular case

With the blow-up trick described in subsection 4.1.2 as a new ingredient, we can generalize theorem 4.1.5 and consider fans which are not horizontal.

**Lemma 4.1.9.** *Let  $\mathcal{F}$  be a non-singular and  $h$ -transverse fan. One of the following is true.*

- (1) *The fan  $\mathcal{F}$  is congruent to an  $h$ -transverse and horizontal fan.*
- (2) *The fan  $\mathcal{F}$  has a single vertical ray. In that case  $\mathcal{F}$  is obtained from a non-singular and  $h$ -transverse fan with 3 rays performing several blow-ups.*

*Proof.* If the fan  $\mathcal{F}$  is horizontal it obviously fits into point (1). We assume now that  $\mathcal{F}$  is not horizontal.

Assume first that  $\mathcal{F}$  has no vertical ray. Let  $n \in \mathbb{N}$  be the biggest integer such that  $\mathcal{F}$  has a ray generated by  $(\pm 1, \pm n)$ . By symmetries we can only consider the case of  $(1, n)$ . Necessarily  $n > 0$  otherwise  $\mathcal{F}$  is not complete.

Let  $u_1, \dots, u_k$  be the primitive generators of the rays of  $\mathcal{F}$ , taken in the anticlockwise direction and with  $u_1 = (1, n)$ . Write  $u_2 = (a, b)$ . Because  $\mathcal{F}$  is  $h$ -transverse one has  $a \in \{0, 1, -1\}$ . By hypothesis  $a \neq 0$ , and  $a \neq 1$  otherwise  $b$  would be greater than  $n$ . Hence  $u_2 = (-1, b)$  and one has  $b + n = 1$  because  $\mathcal{F}$  is non-singular, so  $u_2 = (-1, 1 - n)$ .

Write  $u_3 = (c, d)$ . By hypothesis one has  $c = \pm 1$  and  $-d \pm (n - 1) = 1$ , hence  $u_3 = (-1, -n)$  or  $u_3 = (1, n - 2)$ . If  $u_3 = (-1, -n) = -u_1$  then with the same argument one has  $u_4 = -u_2$  and there is no more ray, i.e.  $k = 4$ . If  $u_3 = (1, n - 2)$  then the only possibility for  $u_4$  is  $u_4 = (1, n - 1)$  and there is no more ray, i.e.  $k = 4$ . This gives two possible fans we show on figure 4.7a. Applying the matrices  $\begin{pmatrix} n & -1 \\ 1 - n & 1 \end{pmatrix}$  and  $\begin{pmatrix} n - 1 & -1 \\ 1 & 0 \end{pmatrix}$  we see these fans are congruent to the fans of figure 4.7b, so (1) is true.

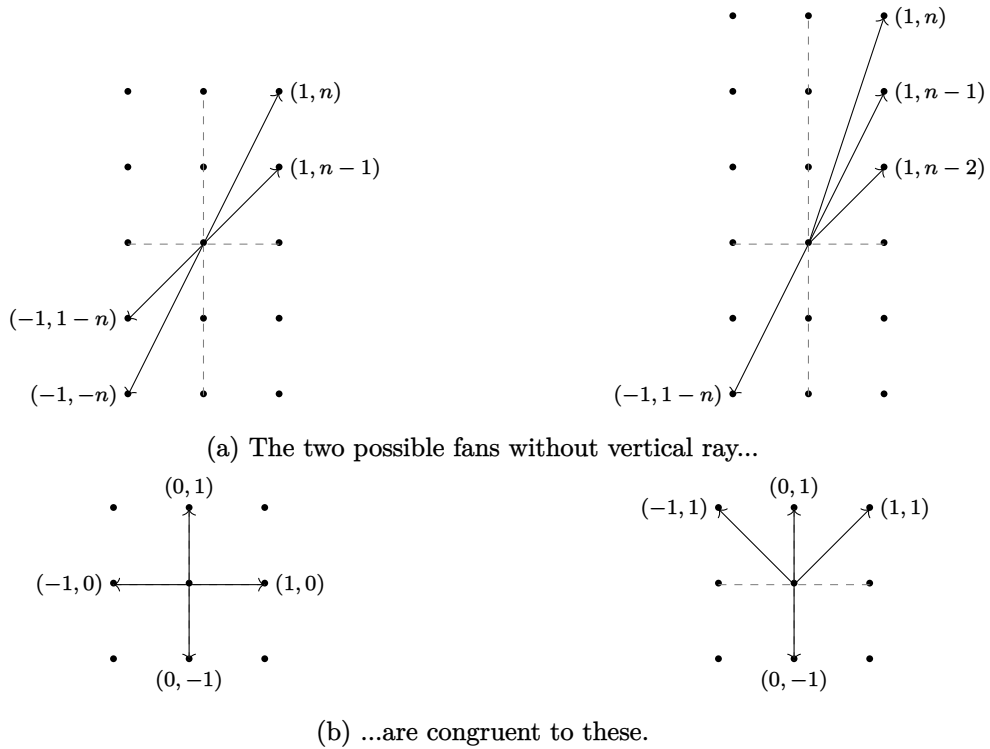

Figure 4.7

Assume now that  $\mathcal{F}$  has a single vertical ray. By symmetry we can assume that this ray is generated by  $(0, -1)$ . Let  $n \in \mathbb{N}$  be the biggest integer such that  $\mathcal{F}$  has a ray generated by  $(\pm 1, n)$ . By symmetry we can only consider the case of  $(1, n)$ . Necessarily  $n > 0$  otherwise  $\mathcal{F}$  is not complete.



Let  $u_1, \dots, u_k$  be the primitive generators of the rays of  $\mathcal{F}$ , taken in the anticlockwise direction and with  $u_1 = (1, n)$ . As previously one has  $u_2 = (-1, 1 - n)$ . The sequence of generators afterwards is of the form  $u_j = (-1, 3 - n - j)$  for  $3 \leq j \leq \ell - 1$  for some  $3 \leq \ell \leq k$ , and  $u_\ell = (0, -1)$ . The  $k - \ell$  remaining generators are necessarily the vectors  $u_j = (1, n - k + j - 1)$  for  $\ell + 1 \leq j \leq k$ . Hence  $\mathcal{F}$  is the fan of figure 4.8a. Consider the non-singular and  $h$ -transverse fan  $\mathcal{F}'$  depicted in figure 4.8b. Then  $\mathcal{F}$  can be obtained from  $\mathcal{F}'$  performing blow-ups, and thus (2) is true.  $\square$

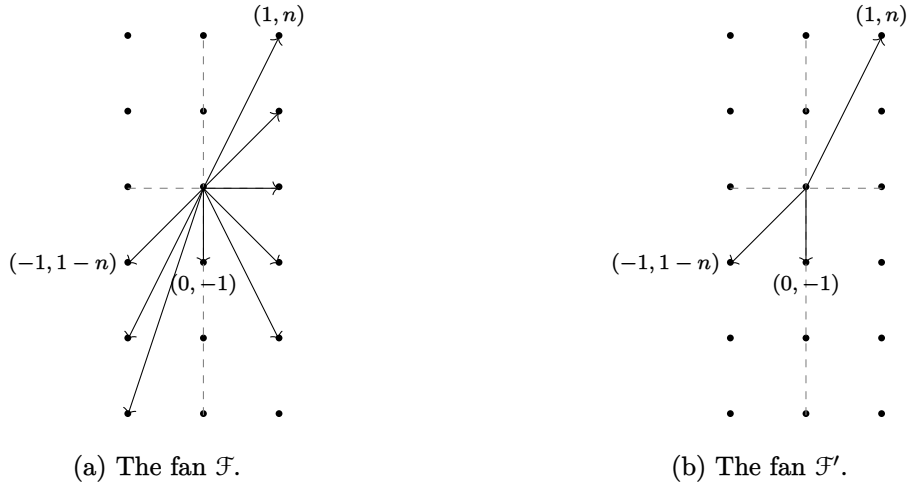

Figure 4.8

If  $\Delta$  and  $\Delta'$  are congruent then  $G_0(\Delta, s) = G_{\Delta'}(0; s)$ . Hence by the previous lemma we can only consider polygons having one or two horizontal sides, i.e. fans having one or two vertical rays.

**Theorem 4.1.10.** *Let  $i \in \mathbb{N}$  and  $\mathcal{F}$  be a non-singular and  $h$ -transverse fan. Let  $\Delta \in D(\mathcal{F})$  and  $s \in \{0, \dots, s_{\max}(\Delta, 0)\}$ . If*

(1) *the fan  $\mathcal{F}$  is horizontal and*

$$\begin{cases} \Delta > 2(i + 2) \\ e^{+\infty}(\Delta) > i + (a(\Delta) - \lfloor a(\Delta)/2 \rfloor + 1)d_{\mathcal{F}} \\ e^{-\infty}(\Delta) > \max(i + 2s, i + (a(\Delta) - \lfloor a(\Delta)/2 \rfloor + 1)d_{\mathcal{F}}) \end{cases}$$

or

2. the fan  $\mathcal{F}$  has a single vertical ray generated by  $(0, \varepsilon)$ , with  $\varepsilon \in \{-1, 1\}$ , and

$$\begin{cases} \Delta > 2(i+2) \\ a(\Delta) > \max(i+2s, 5(i+1)+6) \\ e^{\varepsilon\infty}(\Delta) > \max(i+2s, 5(i+1)+6, i+(a(\Delta)-\lfloor a(\Delta)/2 \rfloor + 1)d_{\mathcal{F}}) \end{cases}$$

then one has

$$\langle G_0(\Delta, s) \rangle_i = P_i(y(\Delta), \chi(\Delta), s).$$

*Proof.* In case (1) we can apply theorem 4.1.5.

In case (2), by lemma 4.1.9 and up to symmetries the fan  $\mathcal{F}$  is obtained by several blow-ups from the fan of figure 4.8b. This fan is congruent to the fan whose rays are generated by  $(-1, 0)$ ,  $(0, -1)$  and  $(1, 1)$ , which defines  $\mathbb{CP}^2$ . Hence we can use corollary 4.1.8, invariance under  $\mathrm{GL}_2(\mathbb{Z})$  and translations, and several applications of corollary 4.1.7 to conclude.  $\square$

#### 4.1.4 The case of singular surfaces

The results of sections 4.1.1 and 4.1.2 can be extended to singular surfaces. Recall that for a polygon  $\Delta$ , we denote by  $n_k(\Delta)$  its number of vertices of index  $k$ . Recall also that we denote by  $(Q_i(y, s, n_1, n_2, \dots))_i$  the coefficients of the formal series

$$\sum_{i \geq 0} Q_i(y, s, n_1, n_2, \dots) x^i := B^s A^{y-2-2s} \prod_{k \geq 0} P(x^k)^{n_k}.$$

Theorem 4.1.5 generalizes as follows.

**Theorem 4.1.11.** *Let  $i \in \mathbb{N}$  and  $\mathcal{F}$  be an  $h$ -transverse and horizontal fan. Let  $\Delta \in D(\mathcal{F})$  and  $s \in \{0, \dots, s_{\max}(\Delta, 0)\}$ . If  $(\Delta, s)$  satisfies*

$$\begin{cases} \Delta > 2(i+2) \\ e^{-\infty}(\Delta) \geq i+2s \\ e^{\pm\infty}(\Delta) > i+(a(\Delta)-\lfloor a(\Delta)/2 \rfloor + 1)d_{\mathcal{F}} \end{cases}$$

then

$$\langle G_0(\Delta, s) \rangle_i = Q_i(y(\Delta), s, n_1(\Delta), \dots).$$

*Remark 4.1.12.* If  $n_k(\Delta) = 0$  unless  $k = 1$ , the product over  $k$  is just  $P^{X(\Delta)}$  and we recover theorem 4.1.5.

*Remark 4.1.13.* For  $k \geq 2$ ,  $n_k(\Delta)$  is the number of singularities of  $X_{\mathcal{F}}$  of index  $k$ , see [LO18, proposition A.1]. Hence the term taking into account the singularities  $\prod_{k \geq 2} P(x^k)^{n_k}$  is the same as the one in [LO18, corollary 1.10].

*Proof.* Let  $m_1 = n_1(\Delta) - 4$  and  $m_k = n_k(\Delta)$  for  $k \geq 2$ . For a vertex of index  $k \geq 1$  of  $\Delta$ , the adjacent edges have outward normal vectors  $(1, q)$  and  $(1, q \pm k)$  for some  $q \in \mathbb{Z}$ . Hence in the choice of the function  $R$  for the construction of a diagram  $\mathcal{D}$  (see proof of lemma 4.1.4) the vector  $\tilde{\gamma}$  will contribute to the codegree by

$$\sum_{j=1}^i k(\tilde{\gamma}_j - j)$$

and if we want  $\text{codeg}(\mathcal{D}) \leq i$  then the corresponding vector  $\gamma$  will satisfy

$$\text{codeg}(\gamma) \leq \frac{i}{k}.$$

Thereby, to choose the functions  $R$  and  $L$  we need, for every  $k \geq 1$ , to choose  $m_k$  vectors  $\gamma_k^1, \dots, \gamma_k^{m_k}$  of codegree at most  $i/k$  and such that

$$\sum_{k \geq 1} \sum_{j=1}^{m_k} \text{codeg}(\gamma_k^j) \leq i.$$

If the divergence contributes  $c$  to the codegree of  $\mathcal{D}$ , then by lemma 4.1.15 the number of choices for  $(R, L)$  is

$$\sum_{c_1+c_2+\dots=c} \prod_{k \geq 1} \sum_{j_1+\dots+j_{m_k}=c_k/k} p(j_1) \dots p(j_{m_k})$$

where  $c_k$  is the contribution of the vertices of index  $k$ . The corresponding generating series is

$$\prod_{k \geq 1} P(x^k)^{m_k}$$

and the rest of the proof is as in theorem 4.1.5. □

If  $\mathcal{F}$  is a fan having two consecutive rays primitively generated by  $u$  and  $v$ , we construct a new fan  $\tilde{\mathcal{F}}$  from  $\mathcal{F}$  by adding a ray generated by  $mu + v$  for some  $m \geq 1$ . In other words, we replace a 2-dimensional cone of  $\mathcal{F}$  of index  $|\det(u, v)|$  by two 2-dimensional cones of indices  $|\det(u, v)|$  and  $m$ . Proposition 4.1.6 deals with the case  $m = 1$  and generalizes as follows. Recall the conditions

$$(\star)_i \begin{cases} \Delta > 2(i+2) \\ e^{-\infty}(\Delta) \geq i+2s \\ e^{-\infty}(\Delta) > i + (a(\Delta) - \lfloor a(\Delta)/2 \rfloor + 1)d_{\mathcal{F}} \end{cases} .$$

**Proposition 4.1.14.** *Let  $\Delta$  be an  $h$ -transverse polygon and  $\tilde{\Delta}$  be a blow-up at the bottom right corner. We depict their bottom right corners in figure 4.9. There exists a series  $C$  such that if*

$(\Delta, s)$  and  $(\tilde{\Delta}, s)$  both satisfy  $(\star)_i$  then  $\langle G_0(\Delta, s) \rangle_i$  is given by the degree  $i$  coefficient of

$$A^{e^{-\infty}(\Delta)-2s} B^s P^2 \times C,$$

and  $\langle G_{\tilde{\Delta}}(0; s) \rangle_i$  is given by the degree  $i$  coefficient of

$$A^{e^{-\infty}(\tilde{\Delta})-2s} B^s P^2 P(x^m) \times C.$$

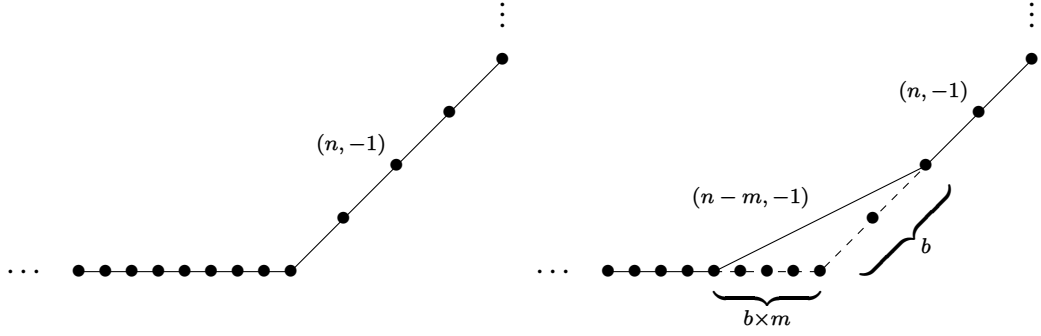

Figure 4.9 – The polygons  $\Delta$  (left) and  $\tilde{\Delta}$  (right).

*Proof.* It is the same proof as proposition 4.1.6, except that to pass from a floor diagram with Newton polygon  $\Delta$  to a floor diagram with Newton polygon  $\tilde{\Delta}$  we drop the divergence of some vertices by  $m$ . Hence, in the computations for  $\tilde{\Delta}$  we need to consider  $\gamma \in B_{k/m}$ , where  $B_{k/m} = \emptyset$  if  $m$  does not divide  $k$ . We will end up with

$$\langle G_{\tilde{\Delta}}(0; s) \rangle_i = \sum_{k=0}^i p\left(\frac{k}{m}\right) \sum_{j=0}^{i-k} \alpha_j(e^{-\infty} - bm, s) \beta_{i-k-j}(a_n)$$

which shows that  $\langle G_{\tilde{\Delta}}(0; s) \rangle_i$  is the degree  $i$  coefficient of the product of

- ▷ the generating series of  $(p(k/m))_k$  which is  $P(x^m)$  by definition,
- ▷ the generating series of  $(\alpha_k(e^{-\infty} - bm, s))_k$  which is  $A^{e^{-\infty} - bm - 2s} B^s P^2$  by lemma 4.1.16,
- ▷ the generating series of  $(\beta_k(a_n))_k$  which is  $C$ .

Since  $e^{-\infty}(\tilde{\Delta}) = e^{-\infty} - bm$  we conclude. □

We could try to generalize theorem 4.1.10 to singular surfaces, but some difficulties appear.

- ▷ If  $\Delta$  is an  $h$ -transverse polygon with one horizontal edge, it can be obtained by several transformations described in proposition 4.1.14 starting from a polygon congruent to the

triangle defining a weighted projective plane  $\mathbb{CP}(1, 1, n)$ . Hence we can link the generating series for  $\Delta$  with the one for  $\mathbb{CP}(1, 1, n)$ , but still we do not know how to compute explicitly the latter, although we conjecture it fits in the general form of theorem 4.1.11.

- ▷ For an  $h$ -transverse and non-horizontal polygon, there is no reason for it to be congruent to an  $h$ -transverse polygon with one horizontal edge (leading to the previous case) or with two horizontal edges (leading to the case of theorem 4.1.11). Hence we are not able to say anything for these polygons, but we conjecture they fit in the general form of theorem 4.1.11.

### 4.1.5 Some technical lemmas

In this section we prove few lemmas regarding the quantities we handled in section 4.1. We refer to the beginning of section 4.1 for the notations.

**Lemma 4.1.15.** *Let  $i \in \mathbb{N}$ . The cardinality of  $B_i$  is  $p(i)$ , the number of partitions of  $i$ .*

*Proof.* Let  $\lambda = (\lambda_1, \dots, \lambda_n)$  be a partition of  $i$ . For  $1 \leq k \leq i$  let  $w_k(\lambda)$  be the number of  $k$  in the sequence  $\lambda$ . Then  $(w_1(\lambda), \dots, w_i(\lambda)) \in B_i$ . Conversely, any  $w \in B_i$  defines a partition  $\lambda(w) = (\lambda_1, \dots, \lambda_n)$  where  $\lambda_j = k$  for  $w_i + \dots + w_{k+1} + 1 \leq j \leq w_i + \dots + w_k$ .  $\square$

**Lemma 4.1.16.** (1) *Let  $a, p \in \mathbb{N}$  and  $S \in \mathbb{N}^{\mathbb{N}}$ . One has*

$$\mathcal{N}(a, p, S) = A^a P^p \prod_{k \geq 0} (x^{2k})^{S_k}.$$

(2) *Let  $s, a, p \in \mathbb{N}$ . One has*

$$\sum_{S \in d(s)} \binom{s}{S} \mathcal{N}(a, p, S) = A^a B^s P^p.$$

*Proof.* (1) We will prove the following formula by induction over  $n$  :

$$\mathcal{N}(a, p, S) = A^a \times \prod_{k=1}^{n-1} \frac{(x^k)^{2S_k}}{(1-x^k)^p} \times (1-x^n)^{a+(n-1)p} \times \mathcal{N}_n(a, p, S)$$

where

$$\mathcal{N}_n(a, p, S) = \sum_{(u_n, \dots)} \nu_{\geq n}(a, p, u, S) x^{\text{codeg}_n(u)} \left( \frac{1-x}{1-x^n} \right)^{\text{sum}_n(u-2S)}.$$

Note that  $\mathcal{N}_1 = \mathcal{N}$  so the formula is true for  $n = 1$ . Assume that the formula holds for some  $n \geq 1$ . Writing  $\nu_*$  as a shortcut for  $\nu_*(a, p, u, S)$  and using the binomial formula we

get

$$\begin{aligned}
 & \mathcal{N}_n(a, p, S) \\
 &= \sum_{(u_{n+1}, \dots)} \nu_{\geq n+1} x^{\text{codeg}_{n+1}(u)} \left( \frac{1-x}{1-x^n} \right)^{\text{sum}_{n+1}(u-2S)} \sum_{u_n \geq 0} \nu_n \left( \frac{x^n - x^{n+1}}{1-x^n} \right)^{u_n - 2S_n} (x^n)^{2S_n} \\
 &= \sum_{(u_{n+1}, \dots)} \nu_{\geq n+1} x^{\text{codeg}_{n+1}(u)} \left( \frac{1-x}{1-x^n} \right)^{\text{sum}_{n+1}(u-2S)} \left( \frac{1-x^{n+1}}{1-x^n} \right)^{a+np - \text{sum}_{n+1}(u-2S)} (x^n)^{2S_n} \\
 &= (x^n)^{2S_n} \left( \frac{1-x^{n+1}}{1-x^n} \right)^{a+np} \mathcal{N}_{n+1}(a, p, S)
 \end{aligned}$$

which gives the desired formula for  $\mathcal{N}(a, p, S)$ .

(2) This results from the previous point and the multinomial formula :

$$\sum_{S \in d(s)} \binom{s}{S} \mathcal{N}(a, p, S) = A^a P^p \sum_{S \in d(s)} \binom{s}{S} \prod_{k \geq 0} (x^{2k})^{S_k} = B^s A^a P^p.$$

□

It is shown in [BJP22, lemma 3.5] that  $\Phi_\ell$  is a polynomial of degree  $\ell$  in  $k$ . Actually we can give an explicit formula for this polynomial.

**Lemma 4.1.17.** *For  $k, \ell \in \mathbb{N}$  one has*

$$\Phi_\ell(k) = \binom{2k + \ell - 1}{\ell}.$$

*Proof.* Here is a combinatorial proof. By definition,

$$\Phi_\ell(k) = \sum_{\substack{i_1 + \dots + i_k = k + \ell \\ i_j \geq 1}} \prod_{j=1}^k i_j = \sum_{\substack{i_1 + \dots + i_k = \ell \\ i_j \geq 0}} \prod_{j=1}^k (i_j + 1).$$

The interpretation is the following. We first need to choose a decomposition of  $\ell$  into  $k$  parts. This is the same as taking  $k + \ell - 1$  white boxes in line and choosing  $k - 1$  of them to be black. The black boxes determine  $k$  groups of  $i_1, \dots, i_k$  white boxes. We add one blue box in each of these groups. Then  $\prod_{j=1}^k (i_j + 1)$  is the number of ways of choosing the places of the blue boxes.

This is the same as taking  $2k + \ell - 1$  whites boxes, then choosing and coloring  $2k - 1$  of them alternately blue and black. Thus

$$\Phi_\ell(k) = \binom{2k + \ell - 1}{2k - 1} = \binom{2k + \ell - 1}{\ell}.$$

□

For  $\ell \in \mathbb{N}$  we can thus extend  $\Phi_\ell$  to a function  $t \in \mathbb{R} \mapsto \Phi_\ell(t)$ .

**Corollary 4.1.18.** *Let  $t \in \mathbb{R}$ . The generating series of  $(\Phi_\ell(t))_{\ell \in \mathbb{N}}$  is  $A^{2t}$ .*

*Proof.* This comes from the fact that  $\binom{2t+\ell-1}{\ell} = (-1)^\ell \binom{-2t}{\ell}$  (see the upper negation in [GKP94, table 174]) and from the binomial formula.  $\square$

**Lemma 4.1.19 ([BJP22, corollary 3.6]).** *Let  $i, k \in \mathbb{N}$  and  $a_1, \dots, a_k > i$  be integers. One has*

$$\left\langle \prod_{j=1}^k [a_j]^2 \right\rangle_i = \Phi_i(k).$$

## 4.2 Genus 0 asymptotic refined invariant

In this section we compute the genus 0 asymptotic refined invariant for any  $h$ -transverse, non-singular and horizontal polygon, i.e. we give another proof of theorem 4.1.5 but working with the asymptotic  $S$ -multiplicity. The interest of this new proof is that it presents methods that can be applied when dealing with genus 1 in chapter 5. However, the previous section is not completely included in this one. Indeed, in this section we will not prove any result concerning non-horizontal polygons ; in particular the invariants related to  $\mathbb{C}\mathbb{P}^2$  will not be handled here. This is because the method we use requires to have a total order on the vertices of the floor diagrams. To remove the horizontal hypothesis, we could use the same techniques as in section 4.1.2, but there is no new idea. For the same reason we will not deal with singular surfaces.

This section is divided as follows. We first show in section 4.2.1 what become the results of section 4.1 when we do not consider the denominators. The rest of the section is devoted to a new proof of theorem 4.1.5. The study is divided in two parts. In section 4.2.2 we look at Hirzebruch surfaces and introduce *words*, which are a way of presenting marked floor diagrams. We then go into the case of  $h$ -transverse, non-singular and horizontal surfaces in section 4.2.3 and show how to manage the non-constant divergence function of the floor diagrams in this setting.

### 4.2.1 Reformulation of theorems of section 4.1

We give in this section a reformulation of the results of section 4.1, in terms of  $G_0^*(\Delta, s)$  and asymptotic refined invariants instead of  $G_0(\Delta, s)$ . We first look at an example to see what happens.

*Example 4.2.1.* We will compute by hand  $AR_{0,s}^{\mathcal{F}_n} \bmod x^3$ , where  $\mathcal{F}_n$  is the fan of figure 2.1b which defines the Hirzebruch surface  $\mathbb{F}_n$ . We thus consider the trapezoid  $\Delta_{a,b}^n$  of figure 2.3a, and look at floor diagrams of genus 0 with Newton polygon  $\Delta_{a,b}^n$ . By lemmas of section 2.2.3 we can only consider diagrams with a total order on their vertices and with large weights on their

bounded edges. By remark 2.3.3, if we consider the pairing  $S = \{\{1, 2\}, \dots, \{2s - 1, 2s\}\}$  then the multiplicity of a marked floor diagram is

$$\mu_S^*(\mathcal{D}, m) = x^{\text{codeg}(\mathcal{D})} (1 - x)^{an+2b} \left( \frac{1+x}{1-x} \right)^s \pmod{x^3}.$$

Hence to compute  $(AR_{0,s}^{\mathcal{F}_n})_i$  we look at the diagrams  $\mathcal{D}$  with  $\text{codeg}(\mathcal{D}) \leq i$ , and for a diagram of codegree  $k$  we are interested in the coefficient of degree  $i - k$  of

$$x^{-k} \mu_S^*(\mathcal{D}, m) = (1 - x)^{an+2b-s} (1 + x)^s \pmod{x^3}.$$

In particular if  $k = i$  this coefficient is 1 and we only need to determine the number of markings compatible with  $S$ .

- ▷ For the constant term of the asymptotic invariant only the unique floor diagram of codegree 0 contributes. This diagram has a single marking, hence  $(AR_{0,s}^{\mathcal{F}_n})_0 = 1$ .

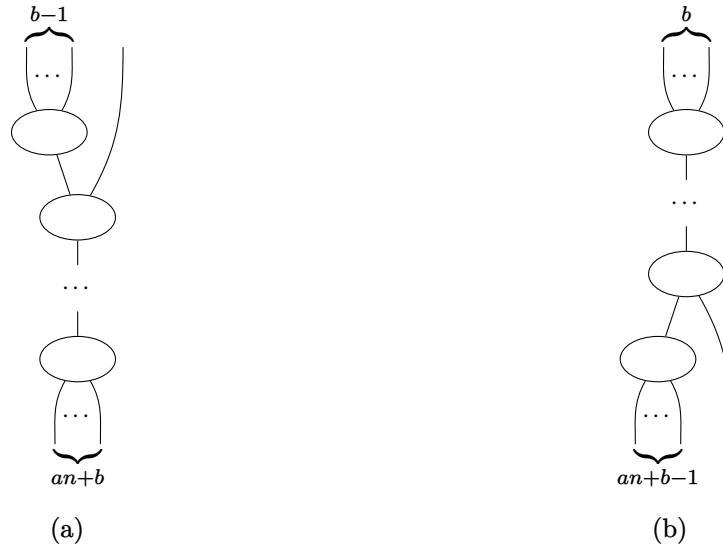

Figure 4.10 – The floor diagrams with Newton polygon  $\Delta_{a,b}^n$  and codegree 1.

- ▷ We now look at the degree 1 term. The degree 1 term of the multiplicity of the floor diagram of codegree 0 is  $-(an + 2b) + 2s$ .

The floor diagrams of codegree 1 are depicted on figure 4.10. The one of figure 4.10a has  $b + 2$  markings, all compatible with the pairing  $S$ , and the degree 1 term of its multiplicity is 1. The one of figure 4.10b has  $an + b + 2$  markings but only  $an + b + 2 - 2s$  of them are compatible with the pairing  $S$ . Indeed, the infinite edge on the right cannot be marked by  $k$  for  $1 \leq k \leq 2s$ . The degree 1 term of the multiplicity of the diagram is 1. In total the codegree 1 diagrams contribute  $an + 2b + 4 - 2s$  to the degree 1 term of the asymptotic



invariant.

Hence one has  $(AR_{0,s}^{\mathcal{F}_n})_1 = 4$ .

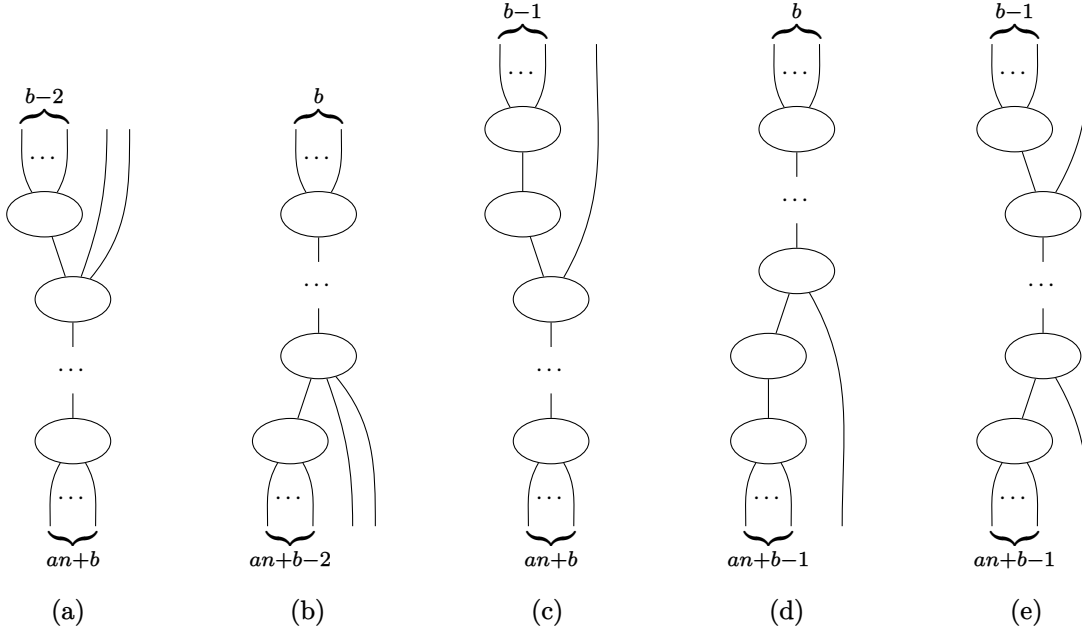

Figure 4.11 – The floor diagrams with Newton polygon  $\Delta_{a,b}^n$  and codegree 2.

▷ Let’s look at the degree 2 term. The degree 2 coefficient of the multiplicity of the codegree 0 diagram is  $\binom{an+2b}{2} - 2s(an + 2b) + 2s^2$ .

The floor diagram of codegree 1 of figure 4.10a contributes  $(b + 2)(-(an + 2b) + 2s)$ , where  $b + 2$  is the number of compatible markings and  $-(an + 2b) + 2s$  is the degree 1 term of the multiplicity. The one of figure 4.10b contributes  $(an + b + 2 - 2s)(-(an + 2b) + 2s)$ .

The floor diagrams of codegree 2 are depicted in figure 4.11. Their contributions are respectively  $\binom{b+2}{2}$  for 4.11a,  $\binom{an+b+2-2s}{2} + s$  for 4.11b,  $b + 4$  for 4.11c,  $an + b + 4 - 2s$  for 4.11d and  $(b + 2)(an + b + 2 - 2s)$  for 4.11e.

Hence one has  $(AR_{0,s}^{\mathcal{F}_n})_2 = 14$ .

These calculations show  $AR_{0,s}^{\mathcal{F}_n} = 1 + 4x + 14x^2 \pmod{x^3}$ . Note that since  $P(x) = 1 + x + 2x^2 \pmod{x^3}$ , one has  $P(x)^4 = 1 + 4x + 14x^2 \pmod{x^3}$ , where  $4 = \chi(\Delta_{a,b}^n)$ . In particular, this does not depend anymore neither on  $y(\Delta_{a,b}^n)$  nor on  $s$ .

When looking at the genus 0 asymptotic refined invariant, this independence with respect to  $y(\Delta)$  and  $s$  is true in general.

**Theorem 4.2.2.** *Let  $\mathcal{F}$  be an  $h$ -transverse fan and  $\Delta \in D(\mathcal{F})$ . Let  $s \in \{0, \dots, s_{\max}(\Delta, 0)\}$  and  $S$  be a pairing of order  $s$ .*

(1) If  $\mathcal{F}$  is non-singular, let  $i_m$  be the maximal integer such that  $(\Delta, s)$  satisfies one of the conditions (1) or (2) of theorem 4.1.10. One has

$$G_0^*(\Delta, s)(x) = P(x)^{\chi(\Delta)} \pmod{x^{i_m}}.$$

In particular it does not depend on  $y(\Delta)$  nor on  $s$ . In other words, the asymptotic refined invariant is

$$AR_{0,s}^{\mathcal{F}}(\Delta) = P(x)^{\chi(\Delta)}.$$

(2) If  $\mathcal{F}$  has two vertical rays, let  $i_m$  be the maximal integer such that  $(\Delta, s)$  satisfies the conditions of theorem 4.1.11. One has

$$G_0^*(\Delta, s)(x) = \prod_{k \geq 1} P(x^k)^{n_k(\Delta)} \pmod{x^{i_m}}.$$

In particular it does not depend on  $y(\Delta)$  nor on  $s$ . In other words, the asymptotic refined invariant is

$$AR_{0,s}^{\mathcal{F}}(\Delta) = \prod_{k \geq 1} P(x^k)^{n_k(\Delta)}.$$

*Proof.* Recall the transformation  $A \mapsto \tilde{A}$  described in section 2.3.2.

(1) Theorem 4.1.10 shows that

$$\tilde{G}_0(\Delta, s)(x) = A^{y(\Delta)-2-2s} B^s P^{\chi(\Delta)} \pmod{x^{i_m}}$$

i.e. by proposition 2.3.2

$$A^{y(\Delta)-2-2s} B^s G_0^*(\Delta, s)(x) = A^{y(\Delta)-2-2s} B^s P^{\chi(\Delta)} \pmod{x^{i_m}}$$

hence

$$G_0^*(\Delta, s)(x) = P^{\chi(\Delta)} \pmod{x^{i_m}}.$$

(2) Theorem 4.1.11 shows that

$$\tilde{G}_0(\Delta, s)(x) = A^{y(\Delta)-2-2s} B^s \prod_{k \geq 1} P(x^k)^{n_k(\Delta)} \pmod{x^{i_m}}$$

which leads to

$$G_0^*(\Delta, s)(x) = \prod_{k \geq 1} P(x^k)^{n_k(\Delta)} \pmod{x^{i_m}}.$$

□

In other words, in case (1) the degree  $i$  coefficient of  $G_0^*(\Delta, s)$  is given by a polynomial  $P_i^* \in \mathbb{N}[\chi]$  of degree  $i$ , and the generating series of  $(P_i^*)_i$  is  $P^\chi$ . In case (2), the degree  $i$  coefficient of  $G_0^*(\Delta, s)$  is given by a polynomial  $Q_i^* \in \mathbb{N}[n_1, n_2, \dots]$  and the generating series of  $(Q_i^*)_i$  is  $\prod_{k \geq 1} P(x^k)^{n_k}$ . These expressions are easier than the ones of theorems 4.1.10 and 4.1.11. In particular, it is remarkable that they do not depend neither on  $y$  nor on  $s$ .

The rest of this chapter is dedicated to a proof of item (1) of theorem 4.2.2 by directly manipulating  $G_0^*(\Delta, s)$  instead of  $G_0(\Delta, s)$ .

### 4.2.2 The case of Hirzebruch surfaces

We now aim at proving the existence and a formula for *asymptotic refined invariants*. In this section, we deal with the Hirzebruch case, i.e. we investigate formula for the asymptotic invariant  $AR_{0,s}^{\mathcal{F}_n}$  associated to the fan  $\mathcal{F}_n$  of figure 2.1b. To do so, we will compute  $G_0^*(\Delta_{a,b}^n, s)$  modulo  $x^{i+1}$  for some  $i$ , before letting  $i$  goes to  $+\infty$ . Hence we only look at floor diagrams of codegree at most  $i$ . In all this section and the following, we fix the pairing  $S = \{\{1, 2\}, \dots, \{2s-1, 2s\}\}$  of order  $s$ .

As shown in theorem 4.1.5 or in [BJP22, lemma 4.1], if one cares about the asymptotic of coefficients of fixed degree of the refined invariant, only a handful of diagrams contribute. In the Hirzebruch and genus 0 case, provided that  $a > i$ ,  $b > i$  and  $an + b \geq i + 2s$  any marked diagram contributing to a coefficient of degree at most  $i$  of  $G_0^*(\Delta_{a,b}^n, s)$  satisfies the following :

- ▷ the floors are totally ordered in the diagram,
- ▷ some of the sources (resp. sinks) might not be attached to the bottom (resp. top) floor but to another one,
- ▷ the marking of the bottom floor is at least  $2s+1$ , and for any  $\{2j-1, 2j\} \in S$ , the elements paired by  $\{2j-1, 2j\}$  are infinite edges adjacent to the same floor.

Let  $u_j^{\text{bot}}$  (resp.  $u_j^{\text{top}}$ ) be the number of sources (resp. sinks) that skip  $j$  floors. The codegree of a diagram  $\mathcal{D}$  comes from these ends not attached to the extremal floors. It is equal to

$$\text{codeg}(\mathcal{D}) = \sum_{j=1}^{+\infty} j(u_j^{\text{top}} + u_j^{\text{bot}}).$$

Note that this sum is actually finite. As the floors are totally ordered, each diagram is characterized by the numbers  $(u_j^{\text{top}}, u_j^{\text{bot}})$ . We then have to account for the markings. Rather than enumerating the diagrams and count their markings as done in section 4.1, we directly count the marked diagrams with marking compatible with  $S$ , encoding them with *words*.

**From marked diagrams to words**

We consider words over the alphabet  $\{f, e, b_j, t_j\}_{j \in \mathbb{N}}$ . The letters used stand for “floor”, “edge/elevator”, “bottom end” and “top end”. The indices of the letters refer to the number of floors they skip. We first explain how to get a word  $W(\mathcal{D}, m)$  from a genus 0 marked diagram  $(\mathcal{D}, m)$  compatible with  $S$  whose floors are totally ordered. Let  $\Delta_{a,b}^n$  be the Newton polygon of the diagram. The floors of  $\mathcal{D}$  are labelled from 1 to  $a$ . The letters of the word  $W(\mathcal{D}, m)$  are in ordered correspondence with the marked points of  $(\mathcal{D}, m)$  with the following rule :

- ▷ for a marked point on a floor, the letter is  $f$ ,
- ▷ for a marked point on a bounded edge, the letter is  $e$ ,
- ▷ for a marked point on a top end that skips  $j \geq 0$  floors, the letter is  $t_j$ ,
- ▷ for a marked point on a bottom end that skips  $j \geq 0$  floors, the letter is  $b_j$ .

**Definition 4.2.3.** We say that a word  $W = w_1 w_2 \dots$  is  $s$ -compatible if for any  $1 \leq j \leq s$  we have  $w_{2j-1} = w_{2j}$ .

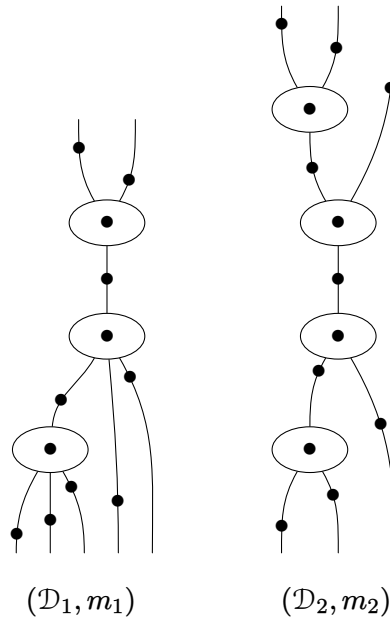

Figure 4.12 – The two marked diagrams of example 4.2.4.

*Example 4.2.4.* On figure 4.12, we depict two genus 0 marked diagrams. On the drawing, the

dots represent the marking of the diagram. Their corresponding words are

$$W(\mathcal{D}_1, m_1) = \mathbf{b}_0\mathbf{b}_0\mathbf{b}_1\mathbf{b}_0\mathbf{f}\mathbf{e}\mathbf{b}_1\mathbf{f}\mathbf{e}\mathbf{f}\mathbf{t}_0\mathbf{t}_0,$$

$$W(\mathcal{D}_2, m_2) = \mathbf{b}_0\mathbf{b}_0\mathbf{f}\mathbf{b}_1\mathbf{e}\mathbf{f}\mathbf{e}\mathbf{f}\mathbf{e}\mathbf{f}\mathbf{t}_1\mathbf{t}_0\mathbf{t}_0.$$

Both words are 1-compatible but not 2-compatible. Note that it is possible to recover the marked diagrams from the words.

This correspondence between diagrams and words is in fact bijective provided we have some assumptions on the words.

**Proposition 4.2.5.** *Let  $(\mathcal{D}, m)$  be a marked floor diagram of Newton polygon  $\Delta_{a,b}^n$  compatible with  $S$ , with  $\text{codeg}(\mathcal{D}) \leq i$  and  $a + b \geq i + 2s$ . Then the word  $W(\mathcal{D}, m)$  satisfies the following.*

(i) *Forgetting about the letters  $\mathbf{b}_*$  and  $\mathbf{t}_*$ , the word is*

$$(\mathbf{f}\mathbf{e})^{a-1}\mathbf{f} = \mathbf{f}\mathbf{e}\mathbf{f}\mathbf{e} \cdots \mathbf{f}\mathbf{e}\mathbf{f}.$$

*Moreover, there are  $a + b$  letters  $\mathbf{b}_*$  and  $b$  letters  $\mathbf{t}_*$ .*

(ii) *Given a letter  $\mathbf{b}_k$ , assume the word forgetting the  $\mathbf{e}$ ,  $\mathbf{t}_j$  and remaining  $\mathbf{b}_j$  is  $\mathbf{f}^p\mathbf{b}_k\mathbf{f}^{a-p}$ , then we have  $k \geq p$ .*

(iii) *Given a letter  $\mathbf{t}_k$ , assume the word forgetting the  $\mathbf{e}$ ,  $\mathbf{b}_j$  and remaining  $\mathbf{t}_j$  is  $\mathbf{f}^{a-p}\mathbf{t}_k\mathbf{f}^p$ , then we have  $k \geq p$ .*

(iv) *The word is  $s$ -compatible.*

*Conversely, a word satisfying the above conditions yields a marked floor diagram compatible with  $S$  and for which the floors are totally ordered.*

*The set of words satisfying the above conditions is denoted by  $\mathcal{W}(\Delta_{a,b}^n, s)$ .*

**Remark 4.2.6.** A marked floor compatible with  $S$  will also be said  $s$ -compatible.

*Proof.* (i) The diagram has  $a$  floors and they are totally ordered, so that each floor is linked to the next one by a unique edge. Thus forgetting about  $\mathbf{t}_*$  and  $\mathbf{b}_*$  we get  $\mathbf{f}\mathbf{e}\mathbf{f} \cdots \mathbf{f}\mathbf{e}\mathbf{f}$ . The numbers of floors as well as the number of ends in each direction are fixed by the Newton polygon  $\Delta_{a,b}^n$ .

(ii) In the word  $\mathbf{f}^p\mathbf{b}_k\mathbf{f}^{a-p}$ , the marking of the end encoded by  $\mathbf{b}_k$  lies between the floors  $p$  and  $p + 1$ . Thus, the end being a bottom end, it skips at least the first  $p$  floors and is attached to a floor after the  $(p + 1)$ -th floor, so that  $k \geq p$ .

(iii) The reasoning is the same but with top ends instead of bottom ends.

(iv) The first  $2s$  marked points lie on ends because  $an + b \geq i + 2s$  and  $\text{codeg}(\mathcal{D}) \leq i$ . As the diagram is  $s$ -compatible, for any  $j \leq s$  the marked points  $2j - 1$  and  $2j$  lie on ends adjacent to the same floor. Thus, the word is also  $s$ -compatible.

For the converse construction, let  $W$  be a word satisfying (i)–(iv). We start with the ordered graph having  $a$  vertices, each linked to the next one by a unique edge with a marking. For each  $b_j$  (resp.  $t_j$ ) we insert a bottom (resp. top) end attached to the floor  $j + 1$  (resp.  $a - j$ ) with a marking lying at the corresponding place in the word. There is a unique way to add weights to the bounded edges so that the diagram is balanced. Condition (i) ensures that the diagram has the right number of floors and ends, and the conditions (ii) and (iii) ensure that it is possible to place the marking of an end on the latter. Condition (iv) ensures that the diagram is also  $s$ -compatible.  $\square$

### Words and codegrees

We define the codegree function on  $\mathcal{W}(\Delta_{a,b}^n, s)$  so that the codegree of a word matches the codegree of the associated diagram. Let  $\mathcal{W}$  be the set of all words on the considered alphabet, which is a monoid. The codegree function is the restriction of the following morphism of monoids :

$$\begin{aligned} \text{codeg} : \quad \mathcal{W} &\rightarrow \mathbb{N} \\ t_j, b_j &\mapsto j \\ e, f &\mapsto 0 \end{aligned}$$

and by construction we have  $\text{codeg}(\mathcal{D}) = \text{codeg}(W(\mathcal{D}, m))$ .

*Example 4.2.7.* We continue example 4.2.4. One has

$$\begin{aligned} \text{codeg}(W(\mathcal{D}_1, m_1)) &= 0 + 0 + 1 + 0 + 1 + 0 + 0 = 2 = \text{codeg}(\mathcal{D}_1), \\ \text{codeg}(W(\mathcal{D}_2, m_2)) &= 0 + 0 + 1 + 1 + 0 + 0 = 2 = \text{codeg}(\mathcal{D}_2). \end{aligned}$$

*Remark 4.2.8.* The definition of  $\mathcal{W}(\Delta_{a,b}^n, s)$  allows the letters  $b_*$  and  $t_*$  to interlace, meaning there might be a  $t_*$  before a  $b_*$ . However, if a  $t_*$  lies before a  $b_*$  then all floors are skipped by at least one of these two ends so that  $\text{codeg}(W(\mathcal{D}, m)) \geq a$ . If we restrict to words of codegree at most  $i$  and if  $a > i$ , then this situation will not appear.

The following lemma describes the shape of the words that have a bounded codegree provided the Newton polygon is large enough.

**Lemma 4.2.9.** *Assume  $i \geq 1$ ,  $a > 2i$ , and  $an + b \geq i + 2s$ . The words in  $\mathcal{W}(\Delta_{a,b}^n, s)$  of codegree*

at most  $i$  have the following form :

$$\begin{aligned} & \mathbf{B}_0 \left[ \prod_{j=1}^i \mathbf{f} \mathbf{B}_j^{(1)} \mathbf{e} \mathbf{B}_j^{(2)} \right] (\mathbf{f} \mathbf{e})^{a-2i} \left[ \prod_{j=1}^i \mathbf{f} \mathbf{T}_{i+1-j}^{(1)} \mathbf{e} \mathbf{T}_{i+1-j}^{(2)} \right] \mathbf{f} \mathbf{T}_0 \\ &= \mathbf{B}_0 \mathbf{f} \mathbf{B}_1^{(1)} \mathbf{e} \mathbf{B}_1^{(2)} \mathbf{f} \mathbf{B}_2^{(1)} \mathbf{e} \mathbf{B}_2^{(2)} \cdots \mathbf{f} \mathbf{e} \mathbf{f} \mathbf{e} \mathbf{f} \mathbf{e} \cdots \mathbf{T}_2^{(1)} \mathbf{e} \mathbf{T}_2^{(2)} \mathbf{f} \mathbf{T}_1^{(1)} \mathbf{e} \mathbf{T}_1^{(2)} \mathbf{f} \mathbf{T}_0, \end{aligned}$$

where  $\mathbf{B}_0$  and  $\mathbf{B}_j^{(k)}$  (resp.  $\mathbf{T}_0$  and  $\mathbf{T}_j^{(k)}$ ) are words in the letters  $\{\mathbf{b}_*\}_{*\geq 0}$  and  $\{\mathbf{b}_*\}_{*\geq j}$  (resp.  $\{\mathbf{t}_*\}_{*\geq 0}$  and  $\{\mathbf{t}_*\}_{*\geq j}$ ), and  $\mathbf{B}_0$  is  $s$ -compatible.

*Proof.* As a letter  $\mathbf{b}_*$  put after the first  $i + 1$  letters  $\mathbf{f}$  contributes at least  $i + 1$  to the codegree, it cannot appear if the latter is assumed to be smaller than  $i$ , and similarly for  $\mathbf{t}_*$  letters. This also implies that the diagram corresponding to the word has at least  $2s$  infinite edges attached to the bottom floor. Hence the first  $2s$  letters  $\mathbf{b}_*$  are before the first letter  $\mathbf{f}$  in the word. Since a word in  $\mathcal{W}(\Delta_{a,b}^n, s)$  is  $s$ -compatible, then so is  $\mathbf{B}_0$ .  $\square$

Basically, the word has a core  $(\mathbf{f} \mathbf{e})^{a-1} \mathbf{f}$  and we insert a word in the letters  $\mathbf{b}_*$  (called  $B$ -word) between each of the  $2i$  consecutive letters on the left, a word in the letters  $\mathbf{t}_*$  (called  $T$ -word) similarly on the right. As the roles of  $B$ -words and  $T$ -words are symmetric, we call them “end-words”. We denote by  $\mathcal{S}$  the set of sentences, i.e. of families of end-words in  $\mathbf{s}_*$  where  $\mathcal{S}, \mathbf{s}$  are meant to be replaced by  $\mathcal{T}, \mathbf{t}$  or  $\mathcal{B}, \mathbf{b}$ :

$$\mathcal{S} = \{(\mathcal{S}_0, \mathcal{S}_1^{(1)}, \mathcal{S}_1^{(2)}, \dots, \mathcal{S}_i^{(1)}, \mathcal{S}_i^{(2)}) \mid i \geq 0, \mathcal{S}_j^{(k)} \text{ word in } \{\mathbf{s}_*\}_{*\geq j}\}.$$

It is endowed with functions

$$\begin{aligned} \text{codeg} &: \mathcal{S} \rightarrow \mathbb{N}, \\ \ell_0, \ell_j^{(k)} &: \mathcal{S} \rightarrow \mathbb{N}, \\ \ell &: \mathcal{S} \rightarrow \mathbb{N}, \end{aligned}$$

that associate to a sentence in  $\mathcal{S}$  the sum of the codegrees of its words, the length of the words  $\mathcal{S}_0$  and  $\mathcal{S}_j^{(k)}$  (maybe 0), and the sum of their lengths. For  $l \geq 0$  we denote by  $\mathcal{S}(l)$  the set of sentences with total length  $l$ , and  $\mathcal{S}^s(l)$  the subset of sentences with length  $l$  such that  $\mathcal{S}_0$  a is  $s$ -compatible word. Lemma 4.2.9 asserts that choosing a word in  $\mathcal{W}(\Delta_{a,b}^n, s)$  having codegree at most  $i$  and with  $a, b$  large enough amounts to choose :

- ▷ an element  $\mathbf{b} \in \mathcal{S}^s(an + b)$  that encodes the  $B$ -words,
- ▷ an element  $\mathbf{t} \in \mathcal{S}(b)$  that encodes the  $T$ -words,

such that  $\text{codeg}(\mathbf{t}) + \text{codeg}(\mathbf{b}) \leq i$ . Essentially, elements of  $\mathcal{S}^s(an + b)$  and  $\mathcal{S}(b)$  tell us how to

construct half-diagrams which are glued back together. Hence, the computation of a generating series over  $\mathcal{W}(\Delta_{a,b}^n, s)$  will split into the computations of some generating series over  $\mathcal{S}^s(an + b)$  and  $\mathcal{S}(b)$ .

**Definition 4.2.10.** We define the  $s$ -multiplicity of a sentence  $\mathfrak{s} \in \mathcal{S}^s(l)$  to be

$$\mu_{\mathcal{S}^s(l)}(\mathfrak{s}) = (1 - x)^l x^{\text{codeg}(\mathfrak{s})} \left( \frac{1 + x}{1 - x} \right)^s.$$

This multiplicity is set to match the multiplicity of the floor diagrams.

**Lemma 4.2.11.** Assume  $i \geq 1$ ,  $a > 2i$  and  $an + b \geq i + 2s$ . The asymptotic  $S$ -multiplicity modulo  $x^{i+1}$  of the marked diagram  $(\mathcal{D}, m)$  encoded by a word  $\mathbf{W} \in \mathcal{W}(\Delta_{a,b}^n, s)$  is

$$(1 - x)^{an+2b} x^{\text{codeg}(\mathbf{W})} \left( \frac{1 + x}{1 - x} \right)^s \pmod{x^{i+1}}.$$

*Proof.* By definition and remark 2.3.3 the multiplicity is

$$(1 - x)^{an+2b} x^{\text{codeg}(\mathcal{D})} \left( \frac{1 + x}{1 - x} \right)^s \prod_{e \in E^0(\mathcal{D})} (1 - x^{w(e)})^2.$$

By construction one has  $\text{codeg}(\mathcal{D}) = \text{codeg}(\mathbf{W})$ . Assume  $\text{codeg}(\mathbf{W}) \leq i$ , otherwise there is nothing to prove since we get 0 modulo  $x^{i+1}$ . By lemma 2.2.30 with  $M = i$ , the unique edge between two consecutive floors has weight bigger than  $i$ . Thus,  $(1 - x^{w(e)})^2 = 1 \pmod{x^{i+1}}$ .  $\square$

### Enumeration of words

We now compute the generating series for words, according to their codegree.

**Lemma 4.2.12.** Let  $l > i \geq 1$ . The generating series of  $s$ -compatible sentences of length  $l$  counted with the  $s$ -multiplicity is

$$\sum_{\mathfrak{s} \in \mathcal{S}^s(l)} \mu_{\mathcal{S}^s(l)}(\mathfrak{s}) = P(x)^2 \pmod{x^{i+1}}.$$

*Proof.* As we are looking at an equality modulo  $x^{i+1}$ , we only care about the elements of  $\mathcal{S}^s(l)$  with codegree at most  $i$  since the other elements contribute 0. In particular, each sentence contains at most  $2i + 1$  words and the letters involved in each word can only be in  $\{\mathfrak{s}_*\}_{0 \leq * \leq i}$ , so that the sum on the left is well-defined modulo  $x^{i+1}$ .

Let's fix  $(l_0, l_j^{(k)})_{\substack{1 \leq j \leq l \\ k=1,2}}$  a family of integers such that  $l = l_0 + \sum_{j,k} l_j^{(k)}$ , and look at sentences  $\mathfrak{s} = (S_0, S_1^{(1)}, \dots, S_l^{(2)})$  with  $\ell_0(\mathfrak{s}) = l_0$  and  $\ell_j^{(k)}(\mathfrak{s}) = l_j^{(k)}$ . The sum of the multiplicities of such



sentences is

$$(1-x)^l \left( \frac{1+x}{1-x} \right)^s \left( \sum_{\substack{\ell(S_0)=l_0 \\ S_0 \text{ s-compatible}}} x^{\text{codeg}(S_0)} \right) \times \prod_{j,k} \left( \sum_{\ell(S_j^{(k)})=l_j^{(k)}} x^{\text{codeg}(S_j^{(k)})} \right).$$

Letters in  $S_j^{(k)}$  can take values in  $\{s_*\}_{* \geq j}$ , so one has

$$\sum_{\ell(S_j^{(k)})=l_j^{(k)}} x^{\text{codeg}(S_j^{(k)})} = \left( \sum_{k \geq j} x^k \right)^{l_j^{(k)}} = \left( \frac{x^j}{1-x} \right)^{l_j^{(k)}}.$$

Letters in  $S_0$  can take values in  $\{s_*\}_{* \geq 0}$ . However, they are not chosen independently since for any of the first  $s$  pairs of letters, the letters of the pair have to take the same value. Thus, we get

$$\begin{aligned} \sum_{\substack{\ell(S_0)=l_0 \\ S_0 \text{ s-compatible}}} x^{\text{codeg}(S_0)} &= \left( \sum_{k \geq 0} x^{2k} \right)^s \left( \sum_{k \geq 0} x^k \right)^{l_0-2s} \\ &= \left( \frac{1}{1-x^2} \right)^s \left( \frac{1}{1-x} \right)^{l_0-2s} \\ &= \left( \frac{1-x}{1+x} \right)^s \left( \frac{1}{1-x} \right)^{l_0}. \end{aligned}$$

Hence the sum of the multiplicities of the sentences with fixed lengths equal to  $(l_0, l_j^{(k)})_{j,k}$  is

$$(1-x)^l \left( \frac{1+x}{1-x} \right)^s \left( \frac{1-x}{1+x} \right)^s \left( \frac{1}{1-x} \right)^{l_0} \prod_{j,k} \left( \frac{x^j}{1-x} \right)^{l_j^{(k)}} = \prod_{j,k} x^{j l_j^{(k)}}.$$

It remains to sum over all the possible choices of  $(l_0, l_j^{(k)})_{j,k}$ . We can forget about  $l_0$  since the tuple is fully determined by the  $l_j^{(k)}$  and the fact that the total length of the sentences is  $l$ . Moreover we can sum over  $l_j^{(k)} \geq 0$  instead of  $\sum l_j^{(k)} \leq l$  because the excess terms will contribute 0 modulo  $x^l$ . Therefore, we get

$$\sum_{(l_0, l_j^{(k)})} x^{\sum j l_j^{(k)}} = \prod_{j,k} \sum_{l_j^{(k)} \geq 0} x^{j l_j^{(k)}} = \left( \prod_{j=1}^n \frac{1}{1-x^j} \right)^2 = P(x)^2 \pmod{x^l}.$$

□

*Remark 4.2.13.* Note that this does not depend on  $s$ , which explain why the asymptotic refined invariant in theorem 4.2.14 below is independent of  $s$ . This was already observed in theorem 4.2.2.

**Theorem 4.2.14.** *The genus 0 asymptotic refined invariant of the Hirzebruch surface  $\mathbb{F}_n$  is*

$$AR_{0,s}^{\mathcal{F}_n} = P(x)^4.$$

*Proof.* We can determine  $AR_{0,s}^{\mathcal{F}_n} \bmod x^{i+1}$  by summing the multiplicities of the words in  $\mathcal{W}(\Delta_{a,b}^n, s)$  of codegree at most  $i$ , with  $a > 2i$  and  $an + b \geq i + 2s$ . According to lemma 4.2.9, choosing a word of codegree at most  $i$  amounts to choose sentences  $\mathfrak{b} \in \mathcal{S}^s(an + b)$  and  $\mathfrak{t} \in \mathcal{S}(b)$  with  $\text{codeg}(\mathfrak{b}) + \text{codeg}(\mathfrak{t}) \leq i$ . Lemma 4.2.11 ensures that the multiplicity of the word is

$$(1-x)^{an+b} x^{\text{codeg}(\mathfrak{b})} \left( \frac{1+x}{1-x} \right)^s \times (1-x)^b x^{\text{codeg}(\mathfrak{t})}.$$

Hence, summing over  $\mathcal{S}^s(an + b) \times \mathcal{S}(b)$  (and potentially counting terms which contribute 0 modulo  $x^{i+1}$ ) the generating series factors modulo  $x^{i+1}$  :

$$\left( (1-x)^{an+b} \left( \frac{1+x}{1-x} \right)^s \sum_{\mathfrak{b} \in \mathcal{S}^s(an+b)} x^{\text{codeg}(\mathfrak{b})} \right) \left( (1-x)^b \sum_{\mathfrak{t} \in \mathcal{S}(b)} x^{\text{codeg}(\mathfrak{t})} \right).$$

Using lemma 4.2.12 we get the result modulo  $x^{i+1}$  for any  $i$ , and we conclude.  $\square$

### 4.2.3 The case of non-singular and horizontal toric surfaces

We now consider the case of a toric surface  $X_{\mathcal{F}}$  associated to an  $h$ -transverse, horizontal and non-singular fan  $\mathcal{F}$ . As in section 4.2.2 we will determine  $AR_{0,s}^{\mathcal{F}}$  by computing  $G_g^*(\Delta, s)$  modulo  $x^{i+1}$ , with  $\Delta \in D(\mathcal{F})$ . Remember we fix the pairing  $S = \{\{1, 2\}, \dots, \{2s-1, 2s\}\}$  of order  $s$ .

#### Words and codegree for $h$ -transverse polygons

Compared to the Hirzebruch case, the marked floor diagrams are modified by incorporating the data  $(L, R)$ , i.e. assigning a pair of integers called *sloping pair* to each floor. According to proposition 2.2.24, the codegree coming from the sloping pairs is

$$\text{codeg}(L, R) = \sum_{\substack{v \prec v' \\ \text{s.t. } L(v) > L(v')}} (L(v) - L(v')) + \sum_{\substack{v \prec v' \\ \text{s.t. } R(v) > R(v')}} (R(v) - R(v')).$$

Elements in each of the sums are called *inversions*. In particular, the contribution to the codegree is 0 if  $L$  and  $R$  are increasing, as seen in proposition 2.2.24.

To enable the word approach to treat the case of  $h$ -transverse polygons, we need to add a sloping pair to each floor. We now consider the alphabet  $\{e, f_{*,*}, t_*, b_*\}$  where the indices of  $f_{*,*}$  are the members of the sloping pair. Similarly to proposition 4.2.5 we have the following proposition that relates words to diagrams.

**Proposition 4.2.15.** *Let  $(\mathcal{D}, m)$  be a  $s$ -compatible marked floor diagram of Newton polygon  $\Delta$ , with  $\text{codeg}(\mathcal{D}) \leq i$  and  $e^{-\infty} \geq i + 2s$ . Then the word  $W(\mathcal{D}, m)$  satisfies the following.*

- (i) *Forgetting about  $b_*$ ,  $t_*$  and indices of  $f_{*,*}$ , the word is  $(fe)^{a-1}f$ . Moreover, there are  $e^{+\infty}$  letters  $t_*$  and  $e^{-\infty}$  letters  $b_*$ .*
- (ii)-(iv) *from proposition 4.2.5 are still satisfied.*

- (v) *If  $k \in b_{\text{left}}(\Delta)$  (resp.  $b_{\text{right}}(\Delta)$ ), the number of appearances of  $k$  as a  $L$ -value (resp.  $R$ -value) in the sloping pairs is the integral length of the edge of  $\Delta$  having outward normal vector  $(-1, k)$  (resp.  $(1, k)$ ).*

We denote by  $\mathcal{W}(\Delta, s)$  the set of words satisfying the above conditions. Given a word  $W \in \mathcal{W}(\Delta, s)$ , there is a unique way to recover a  $s$ -compatible marked floor diagram of Newton polygon  $\Delta$ .

*Proof.* The proof of the four three points is verbatim to those of proposition 4.2.5. The last one results from the definition of sloping pairs. For the converse construction, we also proceed as in proposition 4.2.5. The difference is that when adding the weights of the elevators, we may obtain negative or zero weights. □

*Remark 4.2.16.* During the reconstruction, the weights that appear may be negative. However, for the words of  $\mathcal{W}(\Delta, s)$  that we consider, all the weights will be positive, see point (iii) of lemma 4.2.18.

In a word  $W$ , we say that two letters  $f_{\ell,r}$  and  $f_{\ell',r'}$  appearing in that order form a *left inversion* (resp. *right inversion*) if  $\ell > \ell'$  (resp.  $r > r'$ ). The size of this inversion is the quantity  $\ell - \ell'$  (resp.  $r - r'$ ).

The codegree function on  $\mathcal{W}(\Delta, s)$  is defined to match the codegree of the marked floor diagrams. The difference with the Hirzebruch case is that the codegree comes from the  $T$ -words and  $B$ -words, but also from the sloping pairs :

$$\begin{aligned} \text{codeg} : \mathcal{W}(\Delta, s) &\rightarrow \mathbb{N} \\ W &\mapsto \text{codeg}(\text{ft}(W)) + \text{codeg}(L, R) \end{aligned}$$

where  $\text{ft}(W)$  is the word where we forget the indices of the letters  $f_{*,*}$ .

*Example 4.2.17.* Let  $(\mathcal{D}, m)$  be the marked diagram of figure 4.13. the associated word is

$$W(\mathcal{D}, m) = b_0 b_0 b_1 b_0 f_{1,1} e b_1 f_{0,2} e f_{-1,0} t_0 t_0.$$

The word  $\text{ft}(W)$  is the word  $W(\mathcal{D}_1, m_1)$  of example 4.2.4. Hence one has

$$\text{codeg}(W(\mathcal{D}, m)) = \text{codeg}(\text{ft}(W(\mathcal{D}, m))) + 1 + 2 + 2 = 2 + 5 = 7 = \text{codeg}(\mathcal{D}).$$

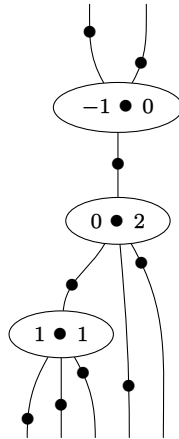

Figure 4.13 – The marked diagram of example 4.2.17.

Up to the indices of letters  $f_{*,*}$ , lemma 4.2.9 still applies for words in  $\mathcal{W}(\Delta, s)$  under the hypothesis  $a > 2i$ ,  $e^{-\infty} \geq i + 2s$ . We deal with the indices of letters  $f_{*,*}$  in the following lemma.

**Lemma 4.2.18.** *Let  $i \geq 1$  and assume that  $\Delta > 2i$ . If  $W \in \mathcal{W}(\Delta, s)$  has codegree at most  $i$  then*

- (i) *all the inversions in the sloping pairs are of size one, i.e. correspond to consecutive sides of the polygon,*
- (ii) *two letters  $f_{*,*}$  part of an inversion are separated by at most  $i - 1$  letters  $f_{*,*}$ ,*
- (iii) *the weights of the edges in the associated diagram are strictly bigger than  $i$ . In particular they are positive, so that  $W$  corresponds to a true marked diagram.*

*Proof.* We denote by  $(L, R)$  the tuple of sloping pairs of  $W$ . We first notice that the tuple  $L$  (and similarly for  $R$ ) differs from the unique tuple of increasing slopes by a finite number of transpositions that switch two consecutive elements. Indeed, this is true for the tuple of codegree 0 since this tuple is increasing. If we consider a tuple of positive codegree then there is a consecutive pair that forms an inversion ; if not the tuple would be increasing. Then, switching both members of the inversion decreases the codegree, and we conclude by induction. Each transposition switching consecutive elements increases the codegree by at least 1, so that if

$\text{codeg}(W) \leq i$  then  $L$  differs from the increasing tuple by at most  $i$  transpositions (and similarly for  $R$ ).

Since  $\Delta$  is non-singular and since the lengths of its sides are larger than  $2i$ , it is not possible to create an inversion of size bigger than 2 with only  $i$  transpositions, proving (i).

Take an inversion  $(\dots, k+1, \dots, k, \dots)$  with  $i$  elements in-between. Any of these  $i$  elements is either  $k$  or  $k+1$ , and provides an inversion either with the left  $k+1$  or with the right  $k$ . Hence we get at least  $1+i$  inversion, which is impossible, proving (ii).

Finally for (iii), lemma 2.2.30 with  $M = i$  ensures that the weights of the bounded edges are strictly bigger than  $i$ . □

### Encoding the sloping pairs

Lemma 4.2.18 states that the elements of the sloping pairs are assigned to the floors with some constraints. We use the following objects to encode these assignments. Let  $\mathcal{P}$  be the set of non-constant sequences  $p \in \{\bullet, \circ\}^{\mathbb{Z}}$ , up to reindexation by translation of the index, such that the set of pairs

$$(p) = \{(k, l) \mid k < l, p_k = \circ, p_l = \bullet\},$$

is finite. These pairs are also called *inversions*. We then set  $\text{codeg}(p) = |I(p)|$ .

*Example 4.2.19.* We consider the following element, for which the first  $\circ$  has index 0:

$$p = \dots \bullet \bullet \bullet \circ \circ \bullet \bullet \bullet \circ \bullet \bullet \circ \circ \circ \dots .$$

Since  $I(p) = \{(0, 2), (0, 4), (0, 5), (0, 7), (1, 2), (1, 4), (1, 5), (1, 7), (3, 4), (3, 5), (3, 7), (6, 7)\}$ , it has codegree 12.

Note that for each element  $p \in \mathcal{P}$ , as it is non-constant it contains at least a  $\circ$  and a  $\bullet$ . Since there is a finite number of pairs  $\circ \prec \bullet$  (i.e. a pair  $k < l$  with  $p_k = \circ$  and  $p_l = \bullet$ ), the sequences is asymptotically constant to  $\bullet$  near  $-\infty$  and to  $\circ$  near  $+\infty$ .

**Lemma 4.2.20.** *Let  $i \geq 1$ . There is a finite number of elements of  $\mathcal{P}$  with codegree smaller than  $i$ , and one has*

$$\sum_{p \in \mathcal{P}} x^{\text{codeg}(p)} = P(x).$$

*Proof.* Let  $p \in \mathcal{P}$  be a sequence with codegree smaller than  $i$ . Choose the reindexation of  $p$  such that  $i$  is the last index whose value is  $\bullet$ . As  $I(p)$  is finite, there is a finite number of  $\circ$  before index  $i$  since each of them yields an inversion. Moreover, none can have negative index otherwise  $p$  would have the form

$$p = \dots \bullet \bullet \bullet \dots \circ [\dots] \bullet \circ \circ \circ \dots ,$$

where the bracketed zone contains  $i$  elements, each of them yielding an inversion, leading to at least  $i + 1$  inversions. Thus the set  $\{p \in \mathcal{P} \mid \text{codeg}(p) \leq i\}$  is finite and the generating series is well-defined.

An element  $p \in \mathcal{P}$  is fully determined by the sequence with finite support  $u(p) = (u_j)_{j \geq 1}$ , with  $u_j$  being the number of  $\bullet$  with  $j \circ$  on their left. The inverse bijection associates to an integer sequence with finite support  $u$  the element of  $\mathcal{P}$  defined as follows :

- ▷ put a  $\circ$  at 0 and  $\bullet$  for negative indices,
- ▷ inductively, starting at  $j = 1$ , put  $u_j \bullet$  and then a new  $\circ$ ,
- ▷ as  $u$  is of finite support, the algorithm finishes by only putting  $\circ$ .

The codegree expresses as

$$\text{codeg}(p) = \sum_{j=1}^{+\infty} j u_j.$$

If  $\text{codeg}(p) \leq i$  then  $u_j = 0$  for  $j > i$ . Computing the generating series modulo  $x^{i+1}$ , we only care about the  $p$  having the sequence  $u(p)$  with support in  $\llbracket 1; i \rrbracket$ , and  $u_j$  may take any value considered that too large values will contribute 0 modulo  $x^{i+1}$ . Thus one has

$$\begin{aligned} \sum_{p \in \mathcal{P}} x^{\text{codeg}(p)} &= \sum_{u_1, \dots, u_i=0}^{+\infty} x^{\sum j u_j} \pmod{x^{i+1}} \\ &= \prod_{j=1}^i \left( \sum_{u_j=1}^{+\infty} x^{j u_j} \right) = \prod_{j=1}^i \frac{1}{1 - x^j} \pmod{x^{i+1}} \\ &= \prod_{j=1}^{+\infty} \frac{1}{1 - x^j} = P(x) \pmod{x^{i+1}}. \end{aligned}$$

As the congruence is true modulo  $x^{i+1}$  for every  $i$ , we get the result. □

*Example 4.2.21.* Continuing example 4.2.19 one has  $u(p) = (0, 1, 2, 1, 0, 0, \dots)$ .

**Lemma 4.2.22.** *Assume  $\Delta > 2i$  and let  $W \in \mathcal{W}(\Delta, s)$  with  $\text{codeg}(W) \leq i$ . Then the data of the sloping pairs  $(L, R)$  is equivalent to the data of an element  $p_c \in \mathcal{P}$  for any corner of  $\Delta$  non-adjacent to a horizontal edge, such that  $\text{codeg}(L, R) = \sum_c \text{codeg}(p_c)$ .*

*Proof.* Let  $(L, R)$  be the tuple of sloping pairs of  $W$ , and let  $n \leq k \leq N$  be the integers such that the edges of the left side of  $\Delta$  have outward normal vectors  $(-1, k)$ . Point (i) of lemma 4.2.18 says that  $L$  writes as a concatenation  $L = (L_n, \dots, L_{N-1})$  where  $L_k$  has the form  $(k, \dots, k, \star, \dots, \star, k + 1, \dots, k + 1)$  with  $\star \in \{k, k + 1\}$ . Given a  $k$ , let  $c_k^L$  be the corner of  $\Delta$  whose adjacent edges have outgoing normal vectors  $(-1, k)$  and  $(-1, k + 1)$ . Replacing  $k$  by  $\bullet$  and  $k + 1$  by  $\circ$ , the tuple  $L_k$  gives an element  $p_{c_k^L} \in \mathcal{P}$ . Similarly,  $R$  gives elements  $p_{c_k^R} \in \mathcal{P}$ . By

construction, one has  $\text{codeg}(L, R) = \sum_c \text{codeg}(p_c)$ , where the sum runs over the corners of  $\Delta$  non-adjacent to a horizontal edge.

Conversely, assume we are given a family  $(p_c)_c \in \mathcal{P}^{\chi-4}$ . We construct  $L$  from the elements  $p_{c_k^L}$  corresponding to corners of the left side of  $\Delta$  in the following way. For any  $k$ , truncate  $p_{c_k^L}$  just before its first  $\circ$  and just after its last  $\bullet$ . Replacing  $\bullet$  by  $k$  and  $\circ$  by  $k+1$  gives a tuple  $\tilde{L}_k$ . Then  $L$  is the concatenation  $L = (\tilde{L}_n, \dots, k, k, \tilde{L}_k, k+1, k+1, \dots, L_{N-1})$  where we add sufficiently enough  $k$  between  $\tilde{L}_{k-1}$  and  $\tilde{L}_k$  so that the total number of  $k$  is the number given by proposition 4.2.15 (iv). We proceed similarly for  $R$ , and by construction one has  $\text{codeg}(L, R) = \sum_c \text{codeg}(p_c)$ .  $\square$

*Example 4.2.23.* To the tuple  $L = (0, 1, 0, 1, 1, 0, 1, 1, 1, 2, 1, 2, 2)$  we associate the sequences  $p_1 = \dots \bullet \bullet \circ \bullet \circ \bullet \circ \bullet \circ \dots$  and  $p_2 = \dots \bullet \circ \bullet \circ \bullet \circ \bullet \circ \dots$ , where  $\bullet$  and  $\circ$  correspond to 0 and 1 in  $p_1$  (resp. 1 and 2 in  $p_2$ ).

### Enumeration of words in the $h$ -transverse setting

We can now compute the asymptotic refined invariant in genus 0 for  $h$ -transverse, non-singular and horizontal surfaces. The following theorem is equivalent to theorem 4.1.5.

**Theorem 4.2.24.** *Let  $\mathcal{F}$  be an  $h$ -transverse, non-singular and horizontal fan, and let  $s \in \mathbb{N}$ . Let  $\chi$  be the Euler characteristic of the toric surface  $X_{\mathcal{F}}$ . Then the genus 0 asymptotic refined invariant is*

$$AR_{0,s}^{\mathcal{F}} = P(x)^{\chi}.$$

*Proof.* We can determine  $AR_{0,s}^{\mathcal{F}} \bmod x^{i+1}$  by summing the multiplicities of the words of  $\mathcal{W}(\Delta, s)$  of codegree at most  $i$ , with  $\Delta \in D(\mathcal{F})$  such that  $\Delta > 2i$ , and  $e^{-\infty} \geq i + 2s$ .

By lemma 4.2.18 the weight of every bounded edge in the diagram associated to a word  $W \in \mathcal{W}(\Delta, s)$  of codegree at most  $i$  is strictly bigger than  $i$ . Hence the multiplicity modulo  $x^{i+1}$  is

$$(1 - x)^{e^{\infty}} x^{\text{codeg}(W)} \left( \frac{1 + x}{1 - x} \right)^s.$$

The word is fully determined by the following data :

- ▷ an element  $t \in \mathcal{S}(e^{+\infty})$  encoding the  $T$ -words,
- ▷ an element  $b \in \mathcal{S}^s(e^{-\infty})$  encoding the  $B$ -words,
- ▷ an element  $p_c \in \mathcal{P}$  for any of the  $\chi - 4$  corners  $c$  of  $\Delta$  non-adjacent to a horizontal edge,

such that

$$\text{codeg}(W) = \text{codeg}(t) + \text{codeg}(b) + \sum_c \text{codeg}(p_c) \leq i.$$

The data of  $t$  and  $b$  are enough to recover the word up to the indices of the letters  $f_{*,*}$ . The data of the  $p_c$  allows to recover the sloping pairs  $(L, R)$  by lemma 4.2.22. Hence, summing over

$\mathcal{S}^s(e^{-\infty}) \times \mathcal{S}(e^{+\infty}) \times \mathcal{P}^{\chi-4}$  (and potentially counting terms which contribute 0 modulo  $x^{i+1}$ ) the generating series of words counted with multiplicity factors modulo  $x^{i+1}$  :

$$\left( (1-x)^{e^{-\infty}} \left( \frac{1+x}{1-x} \right)^s \sum_{b \in \mathcal{S}^s(e^{-\infty})} x^{\text{codeg}(b)} \right) \left( (1-x)^{e^{+\infty}} \sum_{t \in \mathcal{S}(e^{+\infty})} x^{\text{codeg}(t)} \right) \left( \sum_{p \in \mathcal{P}} x^{\text{codeg}(p)} \right)^{\chi-4}.$$

Using lemmas 4.2.12 and 4.2.20 we obtain for the generating series

$$P(x)^2 \times P(x)^2 \times P(x)^{\chi-4} = P(x)^\chi \pmod{x^{i+1}}.$$

As this is true for every  $i \geq 1$  we get the result.  $\square$

### 4.3 Examples

The formulas we obtain in theorems 4.1.10, 4.1.11 and 4.2.24 are explicit and we can make some computations.

*Example 4.3.1.* The first coefficients of  $A^{y-2-2s} B^s P^\chi$  are

$$\begin{aligned} P_0(y, \chi, s) &= 1, \\ P_1(y, \chi, s) &= y + \chi - 2s - 2, \\ P_2(y, \chi, s) &= \frac{1}{2}(y^2 + 2y\chi + \chi^2 - 4ys - 4\chi s + 4s^2 - 3y - \chi + 8s + 2), \\ P_3(y, \chi, s) &= \frac{1}{3!}(y^3 + 3y^2\chi + 3y\chi^2 + \chi^3 - 6y^2s - 12y\chi s - 6\chi^2s + 12ys^2 + 12\chi s^2 - 8s^3 \\ &\quad - 3y^2 + 3\chi^2 + 18ys + 6\chi s - 24s^2 + 2y - 4\chi - 16s), \\ P_4(y, \chi, s) &= \frac{1}{4!}(y^4 + 4y^3\chi + 6y^2\chi^2 + 4y\chi^3 + \chi^4 - 8y^3s - 24y^2\chi s - 24y\chi^2s - 8\chi^3s \\ &\quad + 24y^2s^2 + 48y\chi s^2 + 24\chi^2s^2 - 32ys^3 - 32\chi s^3 + 16s^4 - 2y^3 + 6y^2\chi \\ &\quad + 18y\chi^2 + 10\chi^3 + 24y^2s - 24\chi^2s - 72ys^2 - 24\chi s^2 + 64s^3 - y^2 - 14y\chi \\ &\quad - \chi^2 - 32ys + 16\chi s + 80s^2 + 2y + 14\chi + 32s). \end{aligned}$$

*Example 4.3.2.* In the case of degree  $d$  curves on the projective plane  $\mathbb{C}\mathbb{P}^2$ , one has  $y(\Delta) = 3d$  and  $\chi(\Delta) = 3$ , see figure 2.2a. With corollary 4.1.8 one has

$$\begin{aligned} \forall d > \max(11, 2s), \quad \langle G_0(\Delta, s) \rangle_0 &= 1, \\ \forall d > \max(16, 2s), \quad \langle G_0(\Delta, s) \rangle_1 &= 3d - 2s + 1, \\ \forall d > \max(21, 2s), \quad \langle G_0(\Delta, s) \rangle_2 &= \frac{1}{2}(9d^2 - 12ds + 4s^2 + 9d - 4s + 8), \end{aligned}$$



$$\begin{aligned} \forall d > \max(26, 2s), \langle G_0(\Delta, s) \rangle_3 &= \frac{1}{3!} (27d^3 - 54d^2s + 36ds^2 - 8s^3 + 54d^2 - 54ds + 12s^2 \\ &\quad + 87d - 52s + 42), \\ \forall d > \max(31, 2s), \langle G_0(\Delta, s) \rangle_4 &= \frac{1}{4!} (81d^4 - 216d^3s + 216d^2s^2 - 96ds^3 + 16s^4 + 270d^3 \\ &\quad - 432d^2s + 216ds^2 - 32s^3 + 639d^2 - 744ds + 224s^2 \\ &\quad + 690d - 352s + 384). \end{aligned}$$

Note that the bounds we obtain on  $d$  in corollary 4.1.8 are not as sharp as the one in [BJP22, theorem 1.6 and example 1.9].

*Example 4.3.3.* If we consider the asymptotic refined invariant, one has

$$\begin{aligned} P(x)^\chi &= 1 + \chi x + \left( \frac{1}{2}\chi^2 + \frac{3}{2}\chi \right) x^2 + \left( \frac{1}{6}\chi^3 + \frac{3}{2}\chi^2 + \frac{4}{3}\chi \right) x^3 \\ &\quad + \left( \frac{1}{24}\chi^4 + \frac{3}{4}\chi^3 + \frac{59}{24}\chi^2 + \frac{7}{4}\chi \right) x^4 \\ &\quad + \left( \frac{1}{120}\chi^5 + \frac{1}{4}\chi^4 + \frac{43}{24}\chi^3 + \frac{15}{4}\chi^2 + \frac{6}{5}\chi \right) x^5 \\ &\quad + \left( \frac{1}{720}\chi^6 + \frac{1}{16}\chi^5 + \frac{113}{144}\chi^4 + \frac{55}{16}\chi^3 + \frac{1697}{360}\chi^2 + 2\chi \right) x^6 \pmod{x^7} \\ &= 1 + \chi x + \frac{1}{2}\chi(\chi + 3)x^2 + \frac{1}{6}\chi(\chi + 1)(\chi + 8)x^3 \\ &\quad + \frac{1}{24}\chi(\chi + 1)(\chi + 3)(\chi + 14)x^4 \\ &\quad + \frac{1}{120}\chi(\chi + 3)(\chi + 6)(\chi^2 + 21\chi + 8)x^5 \\ &\quad + \frac{1}{720}\chi(\chi + 1)(\chi + 10)(\chi^3 + 34\chi^2 + 181\chi + 144)x^6 \pmod{x^7}. \end{aligned}$$

For Hirzebruch surfaces one has  $\chi = 4$ , and so

$$AR_{0,s}^{\mathcal{F}_n}(x) = 1 + 4x + 14x^2 + 40x^3 + 105x^4 + 252x^5 + 574x^6 \pmod{x^7}.$$

# Generating series in genus 1

---

This chapter is devoted to the study of asymptotic refined invariants in genus 1, using the ideas of section 4.2. To compute the genus 1 asymptotic invariant we will construct floor diagrams of genus 1 by adding an edge to a diagram of genus 0. We can group together the genus 1 diagrams obtained from the same genus 0 diagram, and reduce the enumeration to the genus 0 case, with a multiplicity corresponding to the weighted count of diagrams. As in 4.2 we start with Hirzebruch surfaces before going to  $h$ -transverse, horizontal and non-singular toric surfaces. We compute  $G_1^*(\Delta, s)$  modulo  $x^{i+1}$  for some  $i$ , before letting  $i$  go to  $+\infty$ . As before, we fix the pairing  $S = \{\{1, 2\}, \dots, \{2s - 1, 2s\}\}$  of order  $s$ .

This chapter is based on [BM24]. However, compared to [BM24] we consider here higher genus Göttsche-Schroeter invariants as defined in chapter 3, i.e.  $s$  can be non-zero.

## 5.1 Nerved diagrams : from genus 0 to genus 1 diagrams

To get to the genus 1 case, the idea is that a genus 1 diagram is obtained from a genus 0 diagram by adding one edge, and conversely we get a genus 0 diagram by removing an edge from a genus 1 diagram. However, it might not be clear which edge to remove, and what to do to balance the diagram again. We make this construction precise by introducing the notion of *nerved diagram*.

We fix two integer  $i \in \mathbb{N}$  and  $M \in \mathbb{N}^*$ . In this section  $\Delta$  is an  $h$ -transverse, non-singular and horizontal polygon.

### 5.1.1 Marked nerved diagrams

**Definition 5.1.1.** *Let  $(\mathcal{D}, m)$  be a marked floor diagram of Newton polygon  $\Delta$  and genus  $g$ , with  $a > 2i$  and  $e^{\pm\infty} > (g + 1)M + i$ . Assume  $\text{codeg}(\mathcal{D}) \leq i$ . A nerve for  $\mathcal{D}$  is the choice of an edge between each pair of consecutive floors with weight  $\geq M$ . The data of  $(\mathcal{D}, m)$  with the choice of a nerve is called a nerved marked diagram. We denote with a tilde the nerved marked diagrams, e.g.  $\tilde{\mathcal{D}}$ . To lighten the notation we will not make visible the marking in the notation of nerved marked diagrams.*

*Remark 5.1.2.* Provided  $e^{\pm\infty} > (g + 1)M + i$  and  $\text{codeg}(\mathcal{D}) \leq i$ , lemma 2.2.30 ensures that the

order is total on the vertices of  $\mathcal{D}$ , so all floor diagrams in this chapter will have a total order on their vertices. Moreover, the same lemma ensures the existence of a nerve.

*Remark 5.1.3.* Forgetting about the ends of the diagram, a nerve is a spanning tree of the underlying graph so that there are  $g$  bounded edges not belonging to the nerve.

**Lemma 5.1.4.** *Assume  $e^{\pm\infty} > i + 2M$  and let  $\mathcal{D}$  be a diagram of Newton polygon  $\Delta$  with  $\text{codeg}(\mathcal{D}) \leq i$ .*

- (i) *If  $\mathcal{D}$  is of genus 0, there exists a unique choice of nerve.*
- (ii) *If  $\mathcal{D}$  is of genus 1 with an edge skipping some floors, there exists a unique choice of nerve.*
- (iii) *If  $\mathcal{D}$  is of genus 1 with two edges linking consecutive floors, there are one or two possible nerves depending on whether only one of the edges or both have weight larger than  $M$ .*

*Proof.* This is a reformulation of lemma 2.2.30. □

*Example 5.1.5.* Assume  $M = 1$ , so that there is no condition on the weight of the edges on a nerve. On figure 5.1 we depict three nerved marked diagrams, the nerve consisting in thickened edges. The first nerved diagram is the unique nerved diagram associated to the underlying genus 0 diagram. The remaining two nerved diagrams have the same underlying genus 1 diagram. If  $M = 2$  then  $\tilde{\mathcal{D}}_2$  is a valid nerved diagram, but  $\tilde{\mathcal{D}}_3$  is not.

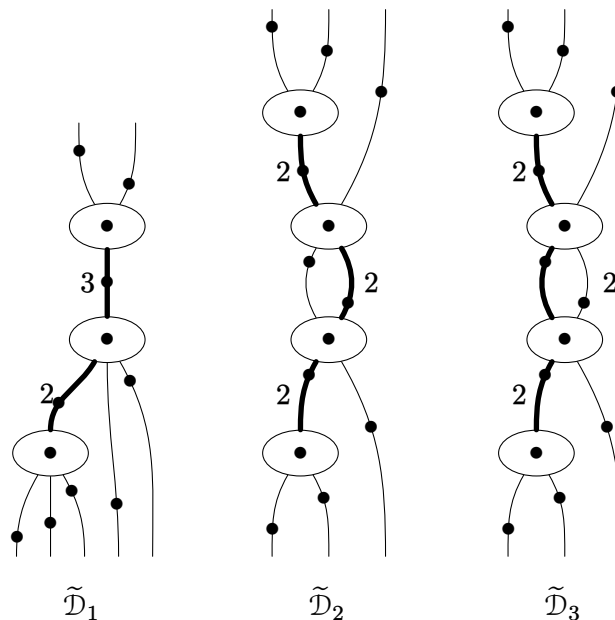

Figure 5.1 – Nerved marked diagrams of genus 0 and 1.

We assign to each nerved marked diagram a multiplicity so that the count of nerved marked diagram matches the count of marked diagrams.

**Definition 5.1.6.** Assume  $e^{\pm\infty} > i + 2M$  and let  $(\mathcal{D}, m)$  be a marked diagram of Newton polygon  $\Delta$ . Let  $N(\mathcal{D})$  be the number of nerves of  $\mathcal{D}$ . The multiplicity of a nerved marked diagram  $\tilde{\mathcal{D}}$  is

$$\mu_S^*(\tilde{\mathcal{D}}) = \frac{1}{N(\mathcal{D})} \mu_S^*(\mathcal{D}, m).$$

### 5.1.2 Constructing genus 1 nerved diagrams from genus 0 ones

We now explain how to construct diagrams of genus 1 from a diagram of genus 0. Let  $\tilde{\mathcal{D}}_g$  be the set of nerved marked diagram of genus  $g$  and Newton polygon  $\Delta$ . Assume  $e^{\pm\infty} > i + 2M$ . There is a map

$$\text{ft} : \tilde{\mathcal{D}}_1 \rightarrow \tilde{\mathcal{D}}_0$$

that forgets the unique bounded edge  $e$  not on the nerve and add  $w(e)$  to the weights of all the edges between the two vertices to which  $e$  was adjacent. Conversely, we can construct a genus 1 nerved marked diagram from a genus 0 one by adding an edge  $e$  with weight  $w$ , and removing  $w$  to the weights of all the edges between the two vertices to which  $e$  is adjacent. This is possible if we are provided with the weight  $w$  of the added edge, the place of its marking between two floors  $k$  and  $k + 1$ , and the floors it is adjacent to, encoded by a pair  $(s_+, s_-)$  that are the numbers of floors it skips above and below its marking. This data is subject to the following constraints :

- ▷  $s_- \leq k - 1$  and  $s_+ \leq a - k - 1$ ,
- ▷  $w \leq \min(w(e')) - M$ , where the minimum is over the weights of the edges of the nerve between the floors  $k - s_-$  and  $k + 1 + s_+$  ; this condition ensures that the weights of the nerve are still larger than  $M$ .

*Example 5.1.7.* Assume  $M = 2$ . On figure 5.2 we depicted various ways to get a genus 1 nerved marked diagram by adding a dashed edge of weight 1 to  $\tilde{\mathcal{D}}_0$ , with marking just above the one of the second floor. If  $(s_+, s_-) = (1, 1)$ , we get  $\tilde{\mathcal{D}}_1$  because the edge skips one floor above its marking, and one below. Taking  $(1, 0)$  or  $(0, 1)$  instead, we get  $\tilde{\mathcal{D}}_2$  and  $\tilde{\mathcal{D}}_3$ . If  $s_+ = s_- = 0$ , we get  $\tilde{\mathcal{D}}_4$ .

Let us try to increase the weight  $w$  of the dashed edge. For  $\tilde{\mathcal{D}}_1, \tilde{\mathcal{D}}_2$  and  $\tilde{\mathcal{D}}_3$ , the weight  $w$  can also be set equal to 2, but not 3 since one of the edges on the nerve would get weight  $1 < M$ . For  $\tilde{\mathcal{D}}_4$ , we can take  $w = 2$  or 3, and in that case the underlying diagram has two possible nerves.

We now relate the multiplicity of a nerved marked diagram constructed by the above process to the multiplicity of the initial genus 0 marked diagram.

**Lemma 5.1.8.** Assume  $M > i$  and  $e^{\pm\infty} > i + 2M$ . Let  $\tilde{\mathcal{D}}$  be a genus 0 nerved marked diagram of Newton polygon  $\Delta$  and with  $\text{codeg}(\tilde{\mathcal{D}}) \leq i$ . Let  $\tilde{\mathcal{E}}$  be the genus 1 nerved marked diagram

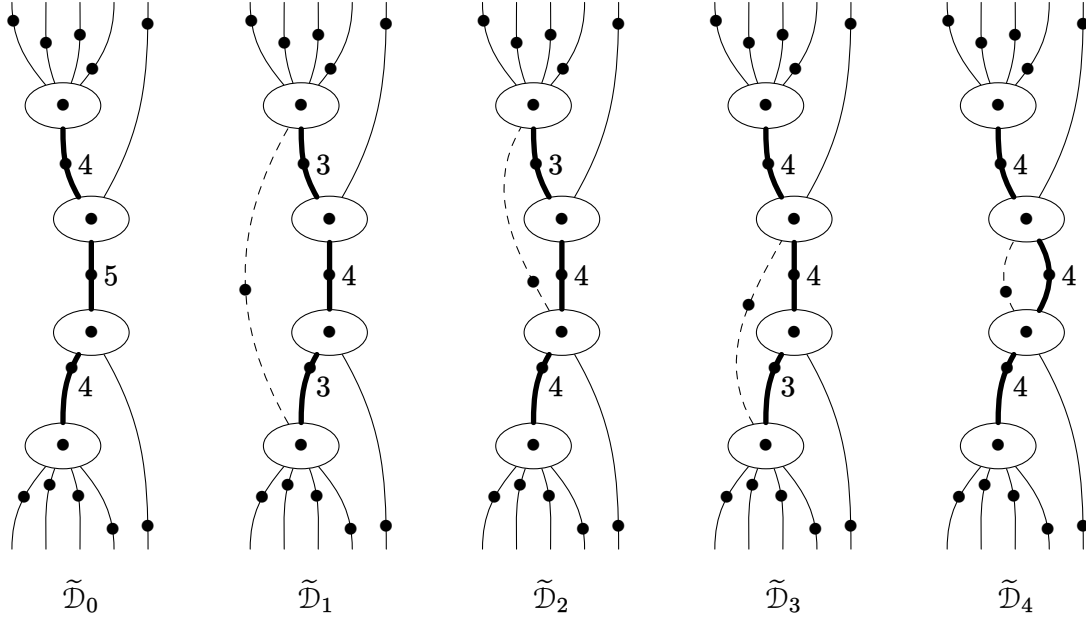

Figure 5.2 – On the left a genus 0 nerved marked diagram. On the right, various genus 1 nerved marked diagrams obtained by adding an edge of weight 1.

constructed by the data of the position of the marking, weight  $w$  and  $(s_+, s_-)$ . Then we have

$$\mu_S^*(\tilde{\mathcal{E}}) = \frac{1}{1 + \mathbb{1}_{w \geq M}} (1 - x^w)^2 x^{w(s_+ + s_-)} \mu_S^*(\tilde{\mathcal{D}}) \pmod{x^{i+1}}.$$

*Proof.* If  $w \geq M$  then  $s_+ = s_- = 0$ , otherwise the codegree would be greater than  $M$ , and also  $i$ . Hence in that case the added edge is adjacent to two consecutive floors and there are two possible nerves for  $\mathcal{E}$ . If  $w < M$ , there is a unique nerve. Hence one has  $N(\mathcal{E}) = 1 + \mathbb{1}_{w \geq M}$ .

By lemma 2.2.30, the hypothesis ensures that the weight of the unique edge between two consecutive floors of  $\mathcal{D}$  is larger than  $2M$ . By the constraint on the choice of  $w$ , these weights are still larger than  $M$  after we added the new edge, so they still do not contribute to the multiplicity modulo  $x^{i+1}$ . Thus, the only edge potentially contributing to the multiplicity of  $\mathcal{E}$  is the one we add, yielding a factor  $(1 - x^w)^2$ . The codegree this edge provides is  $w(s_+ + s_-)$  since it has weight  $w$  and skips exactly  $s_+ + s_-$  floors.  $\square$

Conversely, we can add the multiplicities of the genus 1 nerved marked diagrams constructed from a genus 0 nerved marked diagram. Let  $\langle k \rangle = \frac{x^k}{1 - x^k}$ .

**Lemma 5.1.9.** *Let  $\tilde{\mathcal{D}}$  be a genus 0 nerved marked diagram and let  $1 \leq k \leq a - 1$ . Assume  $M > i$ ,  $a > 2i$  and  $e^{\pm\infty} > i + 2M$ . Let  $\text{pos}_k$  be the number of positions where to insert a marking between the floors  $k$  and  $k + 1$ . Let  $\tilde{\omega}_k$  be the weight of the edge between these floors. The sum of the multiplicities of the genus 1 nerved marked diagrams obtained by inserting an*

edge with a marking between these floors is

$$\text{pos}_k \cdot \left( \frac{\tilde{\omega}_k - 1}{2} - d_k \right) \mu_S^*(\tilde{D}) \pmod{x^{i+1}}, \text{ where } d_k = \begin{cases} \langle k \rangle & \text{if } k \leq i \\ \langle a - k \rangle & \text{if } k \geq a - i \\ 0 & \text{else} \end{cases} .$$

*Proof.* We first choose one of the  $\text{pos}_k$  possible positions for the marking. We then sum over the possible choices of  $w, s_{\pm}$ . There are two cases.

- ▷ If  $s_+ + s_- > 0$ , we can assume the weight  $w$  is bounded by  $i$  since otherwise, we get multiplicity 0 modulo  $x^{i+1}$ .
- ▷ If  $s_+ = s_- = 0$ , the weight  $w$  may takes values from 1 to  $\tilde{\omega}_k - M$ , since the nerve has to keep a weight larger than  $M$ . Furthermore, we start having a factor  $\frac{1}{2}$  for the choices of nerves when  $w \geq M$ . For such a  $w$ , we have  $(1 - x^w)^2 = 1 \pmod{x^{i+1}}$  since  $M > 2i \geq i$ .

Thus by lemma 5.1.8 we have to compute

$$\sum_{w=1}^i \sum_{s_+ + s_- > 0} (1 - x^w)^2 x^{w(s_+ + s_-)} + \sum_{w=1}^{M-1} (1 - x^w)^2 + \sum_{w=M}^{\tilde{\omega}_k - M} \frac{1}{2} \pmod{x^{i+1}} .$$

To compute the first sum, we may add the values for  $w$  going from  $i + 1$  to infinity since they contribute 0 modulo  $x^{i+1}$ . If  $k \leq i$  one has  $s_- \leq k - 1$ , but  $s_+$  can goes to  $+\infty$  since the excess terms contribute 0 modulo  $x^{i+1}$ . In that case we get for the first sum

$$\begin{aligned} \sum_{w=1}^{+\infty} (1 - x^w)^2 \left( \frac{1 - x^{kw}}{(1 - x^w)^2} - 1 \right) &= \sum_{w=1}^{+\infty} \left[ 1 - (1 - x^w)^2 - x^{kw} \right] \\ &= \sum_{w=1}^{+\infty} \left[ 1 - (1 - x^w)^2 \right] - \langle k \rangle . \end{aligned}$$

If  $k \geq a - i$  we have the bound  $s_+ \leq a - k - 1$ , but  $s_-$  can goes to  $+\infty$  and the first sum gives

$$\sum_{w=1}^{+\infty} \left[ 1 - (1 - x^w)^2 \right] - \langle a - k \rangle .$$

If  $i < k < a - i$  then both  $s_-$  and  $s_+$  can go to  $+\infty$  so the first sum is

$$\sum_{w=1}^{+\infty} \left[ 1 - (1 - x^w)^2 \right] .$$

The others two sums are

$$\begin{aligned} \sum_{w=1}^{M-1} (1-x^w)^2 + \sum_{w=M}^{\tilde{\omega}_k-M} \frac{1}{2} &= \sum_{w=1}^{M-1} [(1-x^w)^2 - 1] + M - 1 + \frac{\tilde{\omega}_k - M - M + 1}{2} \\ &= \sum_{w=1}^{+\infty} [(1-x^w)^2 - 1] + \frac{\tilde{\omega}_k - 1}{2} \pmod{x^{i+1}}. \end{aligned}$$

Putting all together, the sums over  $w$  cancel and we get the result.  $\square$

## 5.2 Integration over the space of genus 0 diagrams

In this section we reformulate the problem of summing the multiplicities of the floor diagrams into a calculation of some integrals, with measures that take into account the multiplicities. This formalism lighten notations.

### 5.2.1 Measures and new formalism

In the computation of the genus 0 asymptotic refined invariants in chapter 4, we encoded marked diagrams with words and proved that the set of  $s$ -compatible words is in bijection with a subset of  $\mathcal{S}^s(e^{-\infty}) \times \mathcal{S}(e^{+\infty}) \times \mathcal{P}X^{-4}$ . Elements of  $\mathcal{S}^s(l)$  were assigned multiplicities

$$\mu_{\mathcal{S}^s(l)}(\mathfrak{s}) = (1-x)^l x^{\text{codeg}(\mathfrak{s})} \left( \frac{1+x}{1-x} \right)^s.$$

Recall that there are maps  $\ell_0, \ell_j^{(k)} : \mathcal{S} \rightarrow \mathbb{N}$  that give the lengths of the words of a sentence. Let  $\mathcal{L}$  be the lengths space, i.e. the space of non-negative integer sequences  $(l_j^{(k)})_{j,k}$  with finite support, and  $\pi$  be the product map  $\pi = (\ell_j^{(k)})_{j,k} : \mathcal{S}^s(l) \rightarrow \mathcal{L}$  that maps a sentence to the lengths of its words except the first one. To each element  $\mathbf{l} = (l_j^{(k)})_{j,k} \in \mathcal{L}$ , we assign a weight

$$\mu_{\mathcal{L}}(\mathbf{l}) = \prod_{j,k} x^{j l_j^{(k)}}.$$

During the proof of lemma 4.2.12, we saw that for any  $l$  one has

$$\mu_{\mathcal{S}^s(l)}(\pi^{-1}(\mathbf{l})) := \sum_{\substack{\mathfrak{s} \in \mathcal{S}^s(l) \\ \pi(\mathfrak{s}) = \mathbf{l}}} \mu_{\mathcal{S}^s(l)}(\mathfrak{s}) = \mu_{\mathcal{L}}(\mathbf{l}),$$

in particular it does not depend on  $s$ .

Formally, it is possible to see  $\mu_{\mathcal{S}^s(l)}$  and  $\mu_{\mathcal{L}}$  as measures on their corresponding domains, which are discrete spaces. These measures have values in the quotient ring  $\mathbb{Z}[x]/(x^{i+1})$  for our

choice of  $i$ . From this point of view, weighted sums become integrals. Moreover, this integral is  $\mathbb{Z}[x]/(x^{i+1})$ -linear. There are several reasons for such a consideration : it shortens notations, it becomes easier to see some computational steps, and it formalizes the deletion of diagrams with zero weight. The idea to compute the asymptotic refined invariant in genus 1 is now to integrate the function given by lemma 5.1.9 on the space of genus 0 diagrams.

Lemma 4.2.12 states that  $\mu_{S^s(l)}$  and  $\mu_{\mathcal{L}}$  have total weight  $P(x)^2$ , so that we also consider the normalized measures  $\nu_{S^s(l)} = \frac{1}{P(x)^2} \mu_{S^s(l)}$  and  $\nu_{\mathcal{L}} = \frac{1}{P(x)^2} \mu_{\mathcal{L}}$ . For product spaces, we consider the product measures.

### 5.2.2 Some integral computations

Before going through the main computation in next section, we introduce some functions on  $\mathcal{L}$  and  $S^s(l)$ , and compute their integrals against the normalized measures. Consider first the lengths functions  $\ell_j^{(k)}$ , which are the coordinate functions on  $\mathcal{L}$ . Recall we set  $\langle k \rangle = \frac{x^k}{1-x^k}$ .

**Lemma 5.2.1.** *We have the following integrals :*

$$\begin{aligned} \int_{\mathcal{L}} \ell_m^{(r)} d\nu_{\mathcal{L}} &= \langle m \rangle, \\ \int_{\mathcal{L}} (\ell_m^{(r)})^2 d\nu_{\mathcal{L}} &= \langle m \rangle + 2\langle m \rangle^2, \end{aligned}$$

and for  $(m, r) \neq (m', r')$  one has

$$\int_{\mathcal{L}} \ell_m^{(r)} \ell_{m'}^{(r')} d\nu_{\mathcal{L}} = \langle m \rangle \langle m' \rangle.$$

*Proof.* Indeed, by definition, one has

$$\begin{aligned} \int_{\mathcal{L}} \ell_m^{(r)} d\nu_{\mathcal{L}} &= \sum_{\mathbf{l} \in \mathcal{L}} \ell_m^{(r)}(\mathbf{l}) \frac{\mu_{\mathcal{L}}(\mathbf{l})}{P(x)^2} \\ &= \frac{1}{P(x)^2} \sum_{\mathbf{l} \in \mathcal{L}} l_m^{(r)} \prod_{j,k} x^{j l_j^{(k)}} \\ &= \frac{1}{P(x)^2} \left( \sum_{l_m^{(r)}=0}^{+\infty} l_m^{(r)} x^{m l_m^{(r)}} \right) \prod_{(j,k) \neq (m,r)} \left( \sum_{l_j^{(k)}=0}^{+\infty} x^{j l_j^{(k)}} \right). \end{aligned}$$

Using the identity  $\sum_{n \geq 0} n y^n = \frac{y}{(1-y)^2}$  we get

$$\int_{\mathcal{L}} \ell_m^{(r)} d\nu_{\mathcal{L}} = \frac{1}{P(x)^2} \frac{x^m}{(1-x^m)^2} \prod_{(j,k) \neq (m,r)} \frac{1}{1-x^j} = \frac{x^m}{1-x^m}.$$

For the second integral, we use the identity  $\sum_{n \geq 0} n^2 y^n = \frac{y+y^2}{(1-y)^3}$ . The last one is calculated in



the same way as the first one. □

**Lemma 5.2.2.** *We set  $\ell_m = \ell_m^{(1)} + \ell_m^{(2)}$ . One has*

$$\begin{aligned} \int_{\mathcal{L}} \ell_m d\nu_{\mathcal{L}} &= 2\langle m \rangle, \\ \int_{\mathcal{L}} \ell_m^2 d\nu_{\mathcal{L}} &= 2\langle m \rangle + 6\langle m \rangle^2, \end{aligned}$$

and for  $m \neq m'$  one has

$$\int_{\mathcal{L}} \ell_m \ell_{m'} d\nu_{\mathcal{L}} = 4\langle m \rangle \langle m' \rangle.$$

In particular, the affine function  $e_m = (1 - x^m)^{\frac{\ell_m+2}{2}}$  defined on  $\mathcal{L}$  has integral equal to 1.

*Proof.* The integrals computations are immediate by linearity and lemma 5.2.1. For the last assertion, by  $\mathbb{Z}[x]/(x^{i+1})$ -linearity one has  $\int_{\mathcal{L}} e_m d\nu_{\mathcal{L}} = (1 - x^m)^{\frac{2\langle m \rangle+2}{2}} = 1$ . □

By composing with  $\pi : \mathcal{S}^s(l) \rightarrow \mathcal{L}$  it is possible to pull-back functions on  $\mathcal{L}$  to get functions on  $\mathcal{S}^s(l)$ . Due to the normalization by the total weight, their integrals are preserved.

**Definition 5.2.3.** *We define on  $\mathcal{S}^s(l)$  the leak function  $\phi_m^s[l](\mathfrak{s})$  equal to the number of letters of  $\mathfrak{s}$  with an index larger than  $m$ . To get a function of  $\mathbf{1} \in \mathcal{L}$ , we average over the set  $\pi^{-1}(\mathbf{1}) \cap \mathcal{S}^s(l)$  of  $s$ -compatible sentences with lengths  $\mathbf{1}$  :*

$$\varphi_m^s[l](\mathbf{1}) := \frac{1}{1 - x^m} \frac{1}{\mu_{\mathcal{S}^s(l)}(\pi^{-1}(\mathbf{1}))} \int_{\pi^{-1}(\mathbf{1}) \cap \mathcal{S}^s(l)} \phi_m^s[l] d\mu_{\mathcal{S}^s(l)}.$$

*Remark 5.2.4.* On the diagram side, the leak function  $\phi_m^s[l]$  corresponds to the number of ends skipping the floor  $m$ . If the sum of the weights of the edges between the floors  $m$  and  $m+1$  of a diagram  $\mathcal{D}$  is  $\tilde{\omega}_m$ , the leak function  $\phi_m^s[l]$  is also equal to  $\omega_m - \tilde{\omega}_m$ , where  $\omega_m$  is the maximal possible weight, i.e. the weight of the edge between the floors  $m$  and  $m+1$  in a diagram of genus 0 and codegre 0.

Lemma 5.2.5 expresses the function  $\varphi_m^s[l]$  in terms of the monomials  $\ell_j$  on  $\mathcal{L}$ .

**Lemma 5.2.5.** *We have the following expression on  $\mathcal{L}$  :*

$$\varphi_m^s[l](\mathbf{1}) = l\langle m \rangle - 2sx^m + \psi_m(\mathbf{1}), \quad \text{where } \psi_m = \langle m \rangle \sum_{j=1}^m \frac{\ell_j}{\langle j \rangle} + \sum_{j=m+1}^{+\infty} \ell_j.$$

*Proof.* Let  $\mathbf{1} \in \mathcal{L}$  and  $\mathfrak{s} = (\mathbf{S}_0, (\mathbf{S}_j^{(k)})_{j,k}) \in \pi^{-1}(\mathbf{1}) \cap \mathcal{S}^s(l)$  be a sentence. In terms of the letters, the leak function  $\phi_m^s[l]$  is

$$\phi_m^s[l](\mathfrak{s}) = \sum_{\mathfrak{s} \in \mathbf{S}_0} \mathbb{1}(p \geq m \text{ with } \mathfrak{s} = \mathfrak{s}_p) + \sum_{j,k} \sum_{\mathfrak{s} \in \mathbf{S}_j^{(k)}} \mathbb{1}(p \geq m \text{ with } \mathfrak{s} = \mathfrak{s}_p).$$

Indeed, the leak is due to the ends that skip the floor  $m$ , i.e. the letters  $s_p$  with an index  $p \geq m$ . We need to compute

$$I_s = \int_{\pi^{-1}(\mathbf{1}) \cap \mathcal{S}^s(l)} \mathbb{1}(p \geq m \text{ with } s = s_p) d\mu_{\mathcal{S}^s(l)}$$

for each term  $\mathbb{1}(p \geq m \text{ with } s = s_p)$  corresponding to a position of the letter  $s$  in one of the words  $S_0$  or  $S_j^{(k)}$ . This amounts to compute

$$I_s = (1-x)^l \left( \frac{1+x}{1-x} \right)^s \sum_{s \in \pi^{-1}(\mathbf{1}) \cap \mathcal{S}^s(l)} \mathbb{1}(p \geq m \text{ with } s = s_p) x^{\text{codeg}(s)}.$$

To do so, we proceed as in lemma 4.2.12. If  $\mathbf{l} = (l_0, l_j^{(k)})$  then the sum splits into the product of sums

$$\sum_{\substack{\ell(S_0)=l_0 \\ S_0 \text{ s-compatible}}} \times \prod_{j,k} \sum_{\ell(S_j^{(k)})=l_j^{(k)}}$$

but the values of the letters are constrained by the condition  $(p \geq m \text{ with } s = s_p)$ .

Assume first that the position corresponding to  $s$  is not in  $S_0$ , and let  $S_j^{(k)}$  be the word containing the position of  $s$ . The product of the sums over other words  $S_{j'}^{(k')}$  is

$$\prod_{(j',k') \neq (j,k)} \left( \sum_{p=j'}^{+\infty} x^p \right)^{l_{j'}^{(k')}} = \prod_{(j',k') \neq (j,k)} \left( \frac{x^{j'}}{1-x} \right)^{l_{j'}^{(k')}}.$$

For  $S_j^{(k)}$  we get

$$\left( \sum_{p=j}^{+\infty} x^p \right)^{l_j^{(k)}-1} \left( \sum_{p=j}^{+\infty} \mathbb{1}(p \geq m) x^p \right) = \left( \frac{x^j}{1-x} \right)^{l_j^{(k)}-1} x^{(m-j)_+} \frac{x^j}{1-x}$$

where  $(m-j)_+ = \max(m-j, 0)$ . For the word  $S_0$ , as in lemma 4.2.12 one has

$$\begin{aligned} \sum_{\substack{\ell(S_0)=l_0 \\ S_0 \text{ s-compatible}}} x^{\text{codeg}(S_0)} &= \left( \sum_{k \geq 0} x^{2k} \right)^s \left( \sum_{k \geq 0} x^k \right)^{l_0-2s} \\ &= \left( \frac{1-x}{1+x} \right)^s \left( \frac{1}{1-x} \right)^{l_0}. \end{aligned}$$

Putting all together we get

$$I_s = x^{(m-j)_+} \prod_{j,k} x^{j l_j^{(k)}} = x^{(m-j)_+} \mu_{\mathcal{L}}(\mathbf{l}).$$

Assume now that the position of  $s$  is in  $S_0$ . Then the choices for the letters in the words  $S_j^{(k)}$  give

$$\prod_{j,k} \left( \frac{x^j}{1-x} \right)^{l_j^{(k)}}.$$

For  $S_0$ , if  $s$  is not in the first  $2s$  letters then the computation is as above and in the end one has

$$I_s = x^m \mu_{\mathcal{L}}(\mathbf{1}).$$

It remains to look at the case where the position corresponding to  $s$  is among the first  $2s$  letters. In that case for  $S_0$  we get

$$\begin{aligned} \left( \sum_{k \geq 0} x^{2k} \right)^{s-1} \left( \sum_{p \geq 0} \mathbb{1}(p \geq m) x^{2p} \right) \left( \sum_{k \geq 0} x^k \right)^{l_0-2s} &= \left( \frac{1}{1-x^2} \right)^{s-1} \left( \frac{x^{2m}}{1-x^2} \right) \left( \frac{1}{1-x} \right)^{l_0-2s} \\ &= \left( \frac{1-x}{1+x} \right)^s \left( \frac{1}{1-x} \right)^{l_0} x^{2m}. \end{aligned}$$

This gives

$$I_s = x^{2m} \mu_{\mathcal{L}}(\mathbf{1}).$$

Finally, the integral  $I_s$  is

$$I_s = \mu_{\mathcal{L}}(\mathbf{1}) \begin{cases} x^{2m} & \text{if } s \text{ in the first } 2s \text{ letters,} \\ x^{(m-j)_+} & \text{else.} \end{cases}$$

Adding the above over all the letter positions in the word, and using  $\mu_{S^s(l)}(\pi^{-1}(\mathbf{1})) = \mu_{\mathcal{L}}(\mathbf{1})$  we get

$$\begin{aligned} \varphi_m^s[l](\mathbf{1}) &= \frac{1}{1-x^m} \frac{1}{\mu_{S^s(l)}(\pi^{-1}(\mathbf{1}))} \int_{\pi^{-1}(\mathbf{1}) \cap S^s(l)} \phi_m^s[n] d\mu_{S^s(l)} \\ &= \frac{1}{1-x^m} \left( 2sx^{2m} + (l_0 - 2s)x^m + \sum_{j=1}^m (l_j^{(1)} + l_j^{(2)})x^{m-j} + \sum_{j=m+1}^{+\infty} (l_j^{(1)} + l_j^{(2)}) \right) \\ &= -2sx^m + \left( l - \sum_{j=1}^{+\infty} l_j \right) \langle m \rangle + \sum_{j=1}^m l_j \frac{\langle m \rangle}{x^j} + \sum_{j=m+1}^{+\infty} \frac{l_j}{1-x^m} \\ &= -2sx^m + l \langle m \rangle + \sum_{j=1}^m l_j \langle m \rangle \left( \frac{1}{x^j} - 1 \right) + \sum_{j=m+1}^{+\infty} l_j \left( \frac{1}{1-x^m} - \langle m \rangle \right) \\ &= -2sx^m + l \langle m \rangle + \langle m \rangle \sum_{j=1}^m \frac{l_j}{\langle j \rangle} + \sum_{j=m+1}^{+\infty} l_j \end{aligned}$$

which shows  $\varphi_m^s[l] = l \langle m \rangle - 2sx^m + \psi_m$  as announced.  $\square$

**Lemma 5.2.6.** *We have the following integral :*

$$\int_{\mathcal{L}} e_m \psi_m d\nu_{\mathcal{L}} = (2m+1)\langle m \rangle + 2 \sum_{j=m+1}^{+\infty} \langle j \rangle.$$

*Proof.* By  $\mathbb{Z}[x]/(x^{i+1})$ -linearity and given the definition of  $\psi_m$ , the computation reduces to the computations of  $\int_{\mathcal{L}} e_m \ell_j d\nu_{\mathcal{L}}$ . By definition of  $e_m$  this turns to the computation of  $\int_{\mathcal{L}} \ell_m \ell_j$ , which was handled in lemma 5.2.2. Hence if  $j \neq m$  one has

$$\begin{aligned} \int_{\mathcal{L}} e_m \ell_j d\nu_{\mathcal{L}} &= \int_{\mathcal{L}} (1-x^m) \frac{\ell_m + 2}{2} \ell_j d\nu_{\mathcal{L}} \\ &= \frac{1-x^m}{2} \int_{\mathcal{L}} (\ell_m \ell_j + 2\ell_j) d\nu_{\mathcal{L}} \\ &= \frac{1-x^m}{2} (4\langle m \rangle \langle j \rangle + 4\langle j \rangle) \\ &= 2(1-x^m) \langle j \rangle (\langle m \rangle + 1) \\ &= 2\langle j \rangle, \end{aligned}$$

and for  $j = m$  we get

$$\begin{aligned} \int_{\mathcal{L}} e_m \ell_m d\nu_{\mathcal{L}} &= \int_{\mathcal{L}} (1-x^m) \frac{\ell_m + 2}{2} \ell_m d\nu_{\mathcal{L}} \\ &= \frac{1-x^m}{2} \int_{\mathcal{L}} (\ell_m^2 + 2\ell_m) d\nu_{\mathcal{L}} \\ &= \frac{1-x^m}{2} (2\langle m \rangle + 6\langle m \rangle^2 + 4\langle m \rangle) \\ &= 3(1-x^m) \langle m \rangle (\langle m \rangle + 1) \\ &= 3\langle m \rangle. \end{aligned}$$

Hence,  $\int e_m \ell_j = \int \ell_j$  except for  $j = m$ , where we add  $\langle m \rangle$ . Thus, we have

$$\begin{aligned} \int_{\mathcal{L}} e_m \psi_m d\nu_{\mathcal{L}} &= \int_{\mathcal{L}} \psi_m d\nu_{\mathcal{L}} + \langle m \rangle \\ &= \langle m \rangle \sum_{j=1}^m \frac{2\langle j \rangle}{\langle j \rangle} + \sum_{m+1}^{+\infty} 2\langle j \rangle + \langle m \rangle \\ &= (2m+1)\langle m \rangle + 2 \sum_{j=m+1}^{+\infty} \langle j \rangle. \end{aligned}$$

□

So far, we defined functions on  $S^s(l)$ . The genus 0 marked diagrams of codegree smaller than  $i$  are in bijection with a subset of  $S^s(e^{-\infty}) \times S(e^{+\infty}) \times \mathcal{P}X^{-4}$ . By definition, the complement of

this subset has measure 0 since it consists of elements with codegree strictly larger than  $i$ . Let  $\rho_1, \rho_2$  be the projections of  $\mathcal{S}^s(e^{-\infty}) \times \mathcal{S}(e^{+\infty}) \times \mathcal{P}^{X-4}$  to  $\mathcal{S}^s(e^{-\infty})$  and  $\mathcal{S}(e^{+\infty})$ . We can thus pull-back functions by  $\rho_1$  and  $\rho_2$ .

The number  $\text{pos}_m$  of positions for a marking between the floors  $m$  and  $m + 1$  is :

- ▷ equal to  $\rho_1^* \ell_m + 2 = \rho_1^* \ell_m^{(1)} + \rho_1^* \ell_m^{(2)} + 2$  if  $m \leq i$ , in that case  $\ell_m$  is pull-back from  $\mathcal{S}^s(e^{-\infty})$ ,
- ▷ equal to 2 if  $i < m < a - i$ , since the length functions are 0,
- ▷ equal to  $\rho_2^* \ell_{a-m} + 2$  if  $m \geq a - i$ , in that case  $\ell_{a-m}$  is now pull-back from  $\mathcal{S}(e^{+\infty})$  instead of  $\mathcal{S}^s(e^{-\infty})$ .

There is the same phenomenon for the leak function on a diagram : for  $m \leq i$ , it is the pull-back of the leak function on  $\mathcal{S}^s(e^{-\infty})$ , then it is 0 for  $i < m < a - i$ , and gets pulled-back from  $\mathcal{S}(e^{+\infty})$  for  $m \geq a - i$ .

### 5.3 Computation of the asymptotic refined invariants

We now compute the asymptotic refined invariants in genus 1. We start with the Hirzebruch case, so that the divergence of the floor diagrams is constant. We then explain how to modify the computations of the Hirzebruch case to adapt the proof to any  $h$ -transverse, horizontal and non-singular polygon.

#### 5.3.1 The Hirzebruch case

For  $n$  a positive integer we consider  $\sigma_1(n) = \sum_{d|n} d$  the sum of divisors of  $n$ . Let  $E_2$  be generating series of the function  $\sigma_1$ , i.e.

$$E_2(x) = \sum_{n \geq 1} \sigma_1(n) x^n.$$

**Lemma 5.3.1.** *One has*

$$E_2(x) = \sum_{n=1}^{+\infty} n \frac{x^n}{1-x^n} = \sum_{n=1}^{+\infty} \frac{x^n}{(1-x^n)^2} = \sum_{n=1}^{+\infty} \sum_{j=n}^{+\infty} \frac{x^j}{1-x^j}.$$

*Proof.* Expanding  $\frac{1}{1-x^n}$  in the first sum yields

$$\sum_{n=1}^{+\infty} n \frac{x^n}{1-x^n} = \sum_{n \geq 1} \sum_{k \geq 0} n x^{(k+1)n} = \sum_{m \geq 1} \sigma_1(m) x^m = E_2(x),$$

and expanding it in the second sum gives

$$\begin{aligned} \sum_{n=1}^{+\infty} \frac{x^n}{(1-x^n)^2} &= \sum_{n \geq 1} x^n \left( \sum_{k \geq 0} x^k \right)^2 \\ &= \sum_{n \geq 1} x^n \left( \sum_{k \geq 0} x^{2kn} + 2 \sum_{0 \leq i < j} x^{(i+j)n} \right) \\ &= \sum_{n \geq 1} \sum_{k \geq 0} x^{(2k+1)n} + 2 \sum_{n \geq 0} \sum_{0 \leq i < j} x^{(i+j+1)n}. \end{aligned}$$

If  $k$  is odd it admits  $\frac{k+1}{2}$  decompositions  $k = i + j$  with  $i < j$ , and if  $k$  is even this number of decompositions is  $\frac{k}{2}$ . Hence one has

$$\begin{aligned} \sum_{n=1}^{+\infty} \frac{x^n}{(1-x^n)^2} &= \sum_{n \geq 1} \sum_{k \geq 0} x^{(2k+1)n} + 2 \sum_{n \geq 0} \sum_{0 \leq i < j} x^{(i+j+1)n} \\ &= \sum_{n \geq 1} \sum_{k \text{ even } \geq 0} x^{(k+1)n} + \sum_{n \geq 0} \sum_{k \text{ odd } \geq 0} (k+1)x^{(k+1)n} + \sum_{n \geq 0} \sum_{k \text{ even } \geq 0} kx^{(k+1)n} \\ &= E_2(x). \end{aligned}$$

Finally, the last expression yields the first one when switching the sums over  $n$  and  $j$ .  $\square$

**Theorem 5.3.2.** *Let  $\mathcal{F}_n$  be the fan of figure 2.1b. The genus 1 asymptotic refined invariant of the Hirzebruch surface  $\mathbb{F}_n$  is given by*

$$AR_{1,s}^{\mathcal{F}_n} = P(x)^4 \left( g_{\max} + 2s \frac{x}{1-x} - 12E_2(x) \right),$$

where  $g_{\max} : D(\mathcal{F}_n) \rightarrow \mathbb{N}$  is the function  $\Delta \mapsto g_{\max}(\Delta)$ , i.e.  $g_{\max}(\Delta_{a,b}^n) = \frac{1}{2}(a-1)(an+2b-2)$ .

*Proof.* The computation of the asymptotic refined invariant goes through three steps : expressing then integrating over  $\mathcal{S}^s(an+b) \times \mathcal{S}(b)$  the function from lemma 5.1.9, and summing these integrals over  $m$  from 1 to  $a-1$ .

**First step : expression over  $\mathcal{S}^s(an+b) \times \mathcal{S}(b)$ .** By lemma 5.1.9, the function giving the sum of the multiplicities of the genus 1 marked diagrams created by inserting an edge with marking between the floors  $m$  and  $m+1$  is

$$\text{pos}_m \left( \frac{\tilde{\omega}_m - 1}{2} - d_m \right) = \begin{cases} (\rho_1^* \ell_m + 2) \left( \frac{\omega_m - \rho_1^* \phi_m^s[an+b] - 1}{2} - \langle m \rangle \right) & \text{if } m \leq i \\ \omega_m - 1 & \text{if } i < m < a - i \\ (\rho_2^* \ell_{a-m} + 2) \left( \frac{\omega_m - \rho_2^* \phi_{a-m}^0[b] - 1}{2} - \langle a - m \rangle \right) & \text{if } m \geq a - i \end{cases}$$

where in the first (resp. last) row, functions are pull-back from  $\mathcal{S}^s(an+b)$  (resp.  $\mathcal{S}(b)$ ). For each value of  $m$  we now need to integrate the above function.

**Second step : integration over  $\mathcal{S}^s(an+b) \times \mathcal{S}(b)$ .** If  $i < m < a - i$ , we have

$$\int_{\mathcal{S}^s(an+b) \times \mathcal{S}(b)} (\omega_m - 1) d\nu_{\mathcal{S}^s(an+b)} d\nu_{\mathcal{S}(b)} = \omega_m - 1.$$

Assume now that  $m \leq i$ . Since  $\int_{\mathcal{S}(b)} 1 = 1$  we have

$$\begin{aligned} & \int_{\mathcal{S}^s(an+b) \times \mathcal{S}(b)} (\rho_1^* \ell_m + 2) \left( \frac{\omega_m - \rho_1^* \phi_m^s[an+b] - 1}{2} - \langle m \rangle \right) d\nu_{\mathcal{S}^s(an+b)} d\nu_{\mathcal{S}(b)} \\ &= \int_{\mathcal{S}^s(an+b)} (\ell_m + 2) \left( \frac{\omega_m - \phi_m^s[an+b] - 1}{2} - \langle m \rangle \right) d\nu_{\mathcal{S}^s(an+b)}. \end{aligned}$$

To compute this integral, recall that  $e_m = (1 - x^m)^{\frac{\ell_m+2}{2}}$  so the integrand rewrites

$$e_m(\omega_m - 1) + e_m \left( (\omega_m - 1)\langle m \rangle - \frac{\phi_m^s[an+b]}{1 - x^m} - 2 \frac{x^m}{(1 - x^m)^2} \right).$$

To compute the integral over  $\mathcal{S}^s(an+b)$ , we first integrate over each  $\pi^{-1}(1) \cap \mathcal{S}^s(an+b)$  with the measure  $\mu_{\mathcal{S}^s(an+b)}$  by considering  $\frac{1}{\mu_{\mathcal{L}}(1)} \int_{\pi^{-1}(1) \cap \mathcal{S}^s(an+b)}$ . This gives a function we now integrate over  $\mathcal{L}$ . This function is

$$e_m(\omega_m - 1) + e_m \left( (\omega_m - 1)\langle m \rangle - \varphi_m^s[an+b] - 2 \frac{x^m}{(1 - x^m)^2} \right).$$

Because  $\int_{\mathcal{L}} e_m = 1$  one has  $\int_{\mathcal{L}} e_m(\omega_m - 1) = \omega_m - 1$ . It remains to compute the integral of the correction term  $e_m \left( (\omega_m - 1)\langle m \rangle - \varphi_m^s[an+b] - 2 \frac{x^m}{(1 - x^m)^2} \right)$ . As  $m$  is close to 1 one has

$$\varphi_m^s[an+b] = (an+b)\langle m \rangle - 2sx^m + \psi_m \quad \text{and} \quad \omega_m = (a-m)n + b.$$

Using the above expressions and lemma 5.2.6 we finally get

$$\begin{aligned} & \int_{\mathcal{L}} e_m \left( (\omega_m - 1)\langle m \rangle - \varphi_m^s[an+b] - 2 \frac{x^m}{(1 - x^m)^2} \right) d\nu_{\mathcal{L}} \\ &= \int_{\mathcal{L}} e_m \left( ((a-m)n + b - 1)\langle m \rangle - (an+b)\langle m \rangle + 2sx^m - \psi_m - 2 \frac{x^m}{(1 - x^m)^2} \right) d\nu_{\mathcal{L}} \\ &= \int_{\mathcal{L}} e_m \left( (-mn - 1)\langle m \rangle - \psi_m + 2sx^m - 2 \frac{x^m}{(1 - x^m)^2} \right) d\nu_{\mathcal{L}} \\ &= (-mn - 1)\langle m \rangle + 2sx^m - (2m+1)\langle m \rangle - 2 \sum_{j=m+1}^{+\infty} \langle j \rangle - 2 \frac{x^m}{(1 - x^m)^2} \end{aligned}$$

$$= (-n - 2)m\langle m \rangle + 2sx^m - 2 \sum_{j=m}^{+\infty} \langle j \rangle - 2 \frac{x^m}{(1 - x^m)^2}$$

i.e.

$$\begin{aligned} & \int_{\mathbb{S}^s(an+b) \times \mathbb{S}(b)} \text{pos}_m \left( \frac{\tilde{\omega}_m - 1}{2} - d_m \right) d\nu_{\mathbb{S}^s(an+b)} d\nu_{\mathbb{S}(b)} \\ &= \omega_m - 1 - (n + 2)m\langle m \rangle + 2sx^m - 2 \sum_{j=m}^{+\infty} \langle j \rangle - 2 \frac{x^m}{(1 - x^m)^2}. \end{aligned}$$

If  $m \geq a - i$  the calculations are similar. By first integrating over  $\pi^{-1}(\mathbf{1}) \cap \mathbb{S}(b)$  we then have to compute the integral over  $\mathcal{L}$  of

$$e_{a-m}(\omega_m - 1) + e_{a-m} \left( (\omega_m - 1)\langle a - m \rangle - \varphi_{a-m}^0[b] - 2 \frac{x^{a-m}}{(1 - x^{a-m})^2} \right)$$

The integral of the first term is  $\omega_m - 1$ . For the correction term, one has

$$\varphi_{a-m}^0[b] = b\langle a - m \rangle + \psi_{a-m} \quad \text{and} \quad \omega_m = (a - m)n + b.$$

Thus we get

$$\begin{aligned} & \int_{\mathcal{L}} e_{a-m} \left( (\omega_m - 1)\langle a - m \rangle - \varphi_{a-m}^0[b] - 2 \frac{x^{a-m}}{(1 - x^{a-m})^2} \right) d\nu_{\mathcal{L}} \\ &= \int_{\mathcal{L}} e_{a-m} \left( ((a - m)n + b - 1)\langle a - m \rangle - b\langle a - m \rangle - \psi_{a-m} - 2 \frac{x^{a-m}}{(1 - x^{a-m})^2} \right) d\nu_{\mathcal{L}} \\ &= \int_{\mathcal{L}} e_{a-m} \left( ((a - m)n - 1)\langle a - m \rangle - \psi_{a-m} - 2 \frac{x^{a-m}}{(1 - x^{a-m})^2} \right) d\nu_{\mathcal{L}} \\ &= ((a - m)n - 1)\langle a - m \rangle - (2(a - m) + 1)\langle a - m \rangle - 2 \sum_{j=a-m+1}^{+\infty} \langle j \rangle - 2 \frac{x^{a-m}}{(1 - x^{a-m})^2} \\ &= (n - 2)(a - m)\langle a - m \rangle - 2 \sum_{j=a-m}^{+\infty} \langle j \rangle - 2 \frac{x^{a-m}}{(1 - x^{a-m})^2} \end{aligned}$$

i.e.

$$\begin{aligned} & \int_{\mathbb{S}^s(an+b) \times \mathbb{S}(b)} \text{pos}_m \left( \frac{\tilde{\omega}_m - 1}{2} - d_m \right) d\nu_{\mathbb{S}^s(an+b)} d\nu_{\mathbb{S}(b)} \\ &= \omega_m - 1 + (n - 2)(a - m)\langle a - m \rangle - 2 \sum_{j=a-m}^{+\infty} \langle j \rangle - 2 \frac{x^{a-m}}{(1 - x^{a-m})^2}. \end{aligned}$$

It now remains to sum everything over  $1 \leq m \leq a - 1$ .



**Third step : summation over the values of  $m$ .** We have several sums to compute.

▷ Whatever the value of  $m$  is, the term  $\omega_m - 1$  appears. One has

$$\sum_{m=1}^{a-1} (\omega_m - 1) = g_{\max}$$

since it is the number of interior lattice points of the associated Newton polygon.

▷ We have to sum the correction terms for  $1 \leq m \leq i$ . Since the formula for the correction term gives 0 modulo  $x^{i+1}$  when  $m > i$ , we let  $m$  goes to  $+\infty$ . By lemma 5.3.1, the sum of the correction terms is

$$(-n - 2)E_2(x) + 2s \frac{x}{1-x} - 2E_2(x) - 2E_2(x) = (-n - 6)E_2(x) + 2s \frac{x}{1-x}.$$

▷ For the correction terms for  $a - i \leq m \leq a - 1$ , with  $m' = a - m$  we sum over  $m'$  going from 1 to  $+\infty$  and get

$$(n - 2)E_2(x) - 2E_2(x) - 2E_2(x) = (n - 6)E_2(x).$$

Adding the three contributions we obtained  $g_{\max} + 2s \frac{x}{1-x} - 12E_2(x)$ . Multiplying by the total weight of the space  $P(x)^4$  finishes the computation.  $\square$

### 5.3.2 The case of non-singular and horizontal toric surfaces

The computations made in the Hirzebruch case remain valid with two differences. First, we now need to take into account the sloping pairs of the floors. The marked diagrams of genus 0 and codegree at most  $i$  are in bijection with a subset of  $\mathcal{S}(e^{-\infty}) \times \mathcal{S}(e^{+\infty}) \times \mathcal{P}^{\chi-4}$ , where  $\chi$  is the number of corners of the polygon and  $\mathcal{P}$ , defined in section 4.2.3, encodes the default of increasingness of the slopes. Second, the self-intersection of the divisors corresponding to the top and bottom horizontal sides, equal to  $n$  and  $-n$  for the Hirzebruch surface  $\mathbb{F}_n$ , are not opposite anymore, see lemma 5.3.4.

**Lemma 5.3.3.** *We have the following generating series :*

$$\sum_{p \in \mathcal{P}} \text{codeg}(p) x^{\text{codeg}(p)} = E_2(x) P(x)$$

and for  $n \geq 1$ ,

$$\sum_{p_1, \dots, p_n \in \mathcal{P}} x^{\sum_k \text{codeg}(p_k)} \sum_{k=1}^n \text{codeg}(p_k) = n E_2(x) P(x)^n.$$

*Proof.* For the first formula, we computed in lemma 4.2.20 the generating series of  $x^{\text{codeg}(p)}$ , so

we just need to differentiate the relation, multiply by  $x$  and use lemma 5.3.1 :

$$\begin{aligned} x \frac{d}{dx} \prod_{j=1}^{+\infty} \frac{1}{1-x^j} &= \sum_{m=1}^{+\infty} m \frac{x^m}{(1-x^m)^2} \prod_{j \neq m} \frac{1}{1-x^j} \\ &= \left( \sum_{m=1}^{+\infty} m \frac{x^m}{1-x^m} \right) \prod_{j=1}^{+\infty} \frac{1}{1-x^j} \\ &= E_2(x)P(x). \end{aligned}$$

For the second formula, one has

$$\begin{aligned} \sum_{p_1, \dots, p_n \in \mathcal{P}} x^{\sum_k \text{codeg}(p_k)} \sum_{k=1}^n \text{codeg}(p_k) &= n \sum_{p_1, \dots, p_n \in \mathcal{P}} \text{codeg}(p_1) x^{\sum_k \text{codeg}(p_k)} \\ &= n \sum_{p_1 \in \mathcal{P}} \text{codeg}(p_1) x^{\text{codeg}(p_1)} \sum_{p_2, \dots, p_n \in \mathcal{P}} x^{\text{codeg}(p_2) + \dots + \text{codeg}(p_n)} \\ &= n E_2(x) P(x)^n \end{aligned}$$

by the first formula and lemma 4.2.20. □

**Lemma 5.3.4.** *Let  $\Delta$  be an  $h$ -transverse, horizontal and non-singular polygon. Assume  $\Delta \geq 2i$ . Let  $\mathcal{D}$  be a floor diagram of Newton polygon  $\Delta$ , genus 0 and  $\text{codeg}(\mathcal{D}) \leq i$ . Then the vertices of  $\mathcal{D}$  are totally ordered, and the divergence is constant on its  $i$  lowest and  $i$  highest vertices, equal to respectively  $\min(\text{div})$  and  $\max(\text{div})$ . Moreover, one has*

$$\max(\text{div}) - \min(\text{div}) = \chi(\Delta) - 4.$$

*Proof.* By lemma 2.2.30 the vertices are totally ordered. By lemma 4.1.1 and remark 4.1.3 the divergence is constant on its  $i$  lowest and  $i$  highest vertices. Moreover, one has

$$\min(\text{div}) = \min(R) + \min(L) \quad \text{and} \quad \max(\text{div}) = \max(R) + \max(L).$$

Since  $\Delta$  is non-singular,  $\max(R) - \min(R) + 1$  (resp.  $\max(L) - \min(L) + 1$ ) is the number of edges of  $\Delta$  with outward normal vector having a positive (resp. negative) ordinate. Hence  $\max(\text{div}) - \min(\text{div}) + 4$  is the number of edges of  $\Delta$ , i.e. is equal to  $\chi(\Delta)$ . □

*Remark 5.3.5.* Here is a statement with a more geometric flavor. Let  $X$  be a non-singular toric surface defined by an  $h$ -transverse and horizontal polygon. Let  $D_{\text{top}}$  and  $D_{\text{bot}}$  be the divisors corresponding to the top and bottom horizontal sides of  $\Delta$ . One has  $D_{\text{top}}^2 + D_{\text{bot}}^2 + \chi(X) = 4$ . A geometric proof using divisors and the sheaf of holomorphic functions on  $X$  is given in [BM24].

*Remark 5.3.6.* To rephrase, each vertex of  $\Delta$  non-adjacent to a horizontal edge is responsible

for a drop of the divergence by 1. In general, a vertex of index  $k$  is responsible for an increase of the divergence by  $k$ . Hence, if we remove the non-singularity hypothesis we get

$$\max(\text{div}) - \min(\text{div}) = \sum_{k \geq 0} k n_k(\Delta) - 4.$$

**Theorem 5.3.7.** *Let  $\mathcal{F}$  be an  $h$ -transverse, horizontal and non-singular fan. Let  $g_{\max} : D(\mathcal{F}_n) \rightarrow \mathbb{N}$  be the function  $\Delta \mapsto g_{\max}(\Delta)$ . The genus 1 asymptotic refined invariant is given by*

$$AR_{1,s}^{\mathcal{F}} = P(x)^\chi \left( g_{\max} + 2s \frac{x}{1-x} - 12E_2(x) \right).$$

*Proof.* We proceed as in the Hirzebruch case. Let  $\Delta \in D(\mathcal{F})$  be large enough. Let  $(\mathcal{D}, m)$  be a marked diagram of genus 0 and codegree at most  $i$ , associated to an element of  $\mathcal{S}^s(an + b) \times \mathcal{S}(b) \times \mathcal{P}^{\chi-4}$ . Consider  $\mathfrak{P} = (p_c)_c \in \mathcal{P}^{\chi-4}$  where we choose an element of  $\mathcal{P}$  for each corner of  $\Delta$  non-adjacent to a horizontal edge. Let  $\omega_m^{\mathfrak{P}}$  be the maximum possible weight between the floors  $m$  and  $m+1$  for a given choice of  $\mathfrak{P}$ . It differs from  $\omega_m$  in the following way : any element  $p \in \mathcal{P}$  is the product of exactly  $\text{codeg}(p)$  transpositions, and each of them reduces the weight at the position of the transposition by 1. So one has

$$\begin{aligned} \sum_{m=1}^{a-1} (\omega_m^{\mathfrak{P}} - 1) &= \sum_{m=1}^{a-1} (\omega_m - 1) - \sum_c \text{codeg}(p_c) \\ &= g_{\max} - \sum_c \text{codeg}(p_c), \end{aligned}$$

where the sum is indexed by the corners non-adjacent to a horizontal side.

Let  $n_{\text{top}} = \max(\text{div})$  and  $n_{\text{bot}} = \min(\text{div})$ . For a fixed choice of  $\mathfrak{P} = (p_c)_c \in \mathcal{P}^{\chi-4}$ , the contribution of  $\mathfrak{P}$  to the asymptotic refined invariant is computed as in the Hirzebruch case. We separate into three cases depending on whether  $m \leq i$  or  $i < m < a - i$  or  $a - i \leq m$ . In the first (resp. third) case, the computation in the case of the Hirzebruch surface  $\mathbb{F}_n$  brings a term with  $-n - 6$  (resp.  $n - 6$ ), where  $n$  appears as the divergence of the lowest (resp. highest) vertices. Here, these will be  $-n_{\text{bot}} - 6$  (resp.  $n_{\text{top}} - 6$ ), and so the contribution is

$$x^{\sum_c \text{codeg}(p_c)} P(x)^4 \left[ \sum_{m=1}^{a-1} (\omega_m^{\mathfrak{P}} - 1) + 2s \frac{x}{1-x} - (12 - n_{\text{top}} + n_{\text{bot}}) E_2(x) \right],$$

where the term  $x^{\sum_c \text{codeg}(p_c)}$  accounts for the codegree coming from the sloping pairs. We now replace the sum of weights by its expression in the  $\text{codeg}(p_c)$  and sum over all the possible

$\mathfrak{P} = (\mathfrak{p}_c)_c$ . We get modulo  $x^{i+1}$  :

$$\sum_{\substack{\mathfrak{p}=(\mathfrak{p}_c)_c \\ \text{codeg}(\mathfrak{p}_c) \leq i}} x^{\sum \text{codeg}(\mathfrak{p}_c)} P(x)^4 \left[ \left( g_{\max} - \sum_c \text{codeg}(\mathfrak{p}_c) \right) + 2s \frac{x}{1-x} - (12 - n_{\text{top}} + n_{\text{bot}}) E_2(x) \right].$$

As we only care about the sum modulo  $x^{i+1}$ , we may add all the elements in  $\mathcal{P}$  since the ones with higher codegree will contribute 0. There are  $\chi - 4$  corners where we choose an element  $\mathfrak{p} \in \mathcal{P}$ . Using lemma 4.2.20 and 5.3.3 to compute the generating series, we get

$$P(x)^{\chi-4} P(x)^4 \left[ g_{\max} - (\chi - 4) E_2(x) + 2s \frac{x}{1-x} - (12 - n_{\text{top}} + n_{\text{bot}}) E_2(x) \right] \pmod{x^{i+1}}.$$

Finally, lemma 5.3.4 allows us to conclude.  $\square$

Although it is unlikely that this approach gives explicit results in higher genus (or at the cost of tedious and lengthy calculations), similar ideas could show that the asymptotic refined invariant has the following general form.

**Conjecture 5.3.8.** *Let  $\mathcal{F}$  be an  $h$ -transverse and non-singular fan,  $g \in \mathbb{N}$  and  $s \in \mathbb{N}$ . The asymptotic refined invariant  $AR_{g,s}^{\mathcal{F}}$  has the following form :*

$$AR_{g,s}^{\mathcal{F}}(\Delta) = P(x)^{\chi(\Delta)} \left( \binom{g_{\max}(\Delta)}{g} + Q_g^{\mathcal{F}}(\Delta, s) \right),$$

where  $\Delta$  is a polygon dual to  $\mathcal{F}$ , and where  $Q_g^{\mathcal{F}}$  is a polynomial of degree at most  $g$  in  $\mathcal{L}_{\Delta}^2$ ,  $\mathcal{L}_{\Delta} \cdot K_{X_{\Delta}}$  and  $s$ , whose coefficients are formal series in  $x$  that vanish at 0.

*Example 5.3.9.* By theorem 5.3.7 one has

$$\begin{aligned} AR_{1,s}^{\mathcal{F}} &= g_{\max} + (\chi g_{\max} - 2s - 12)x + \frac{1}{2} \left( \chi^2 g_{\max} + 2\chi g_{\max} - 4\chi s - 24\chi - 4s - 72 \right) x^2 \\ &\quad + \frac{1}{6} \left( \chi^3 g_{\max} + 9\chi^2 g_{\max} - 6\chi^2 s - 36\chi^2 + 8\chi g_{\max} - 30\chi s - 324\chi - 12s - 288 \right) x^3 \\ &\quad + \frac{1}{24} \left( \chi^4 g_{\max} + 18\chi^3 g_{\max} - 8\chi^3 s - 48\chi^3 + 59\chi^2 g_{\max} - 96\chi^2 s \right. \\ &\quad \left. - 864\chi^2 + 42\chi g_{\max} - 184\chi s - 2832\chi - 48s - 2016 \right) x^4 \\ &\quad + o(x^4). \end{aligned}$$

Given

$$g_{\max}(\Delta) = \mathcal{L}_{\Delta}^2 + \frac{K_{X_{\Delta}} \cdot \mathcal{L}_{\Delta}}{2} + 1 = \text{Area}(\Delta) - \frac{y(\Delta)}{2} + 1$$

one has

$$\begin{aligned}
 AR_{1,s}^{\mathcal{F}} &= \frac{1}{2} (2\text{Area} - y + 2) + \frac{1}{2} (2\chi\text{Area} - \chi y + 2\chi - 4s - 24)x \\
 &+ \frac{1}{4} \left( 2\chi^2\text{Area} - \chi^2 y + 2\chi^2 + 6\chi\text{Area} - 3\chi y - 8\chi s - 42\chi - 8s - 144 \right) x^2 \\
 &+ \frac{1}{12} \left( 2\chi^3\text{Area} - \chi^3 y + 2\chi^3 + 18\chi^2\text{Area} - 9\chi^2 y - 12\chi^2 s - 54\chi^2 \right. \\
 &\quad \left. + 16\chi\text{Area} - 8\chi y - 60\chi s - 632\chi - 24s - 576 \right) x^3 \\
 &+ \frac{1}{48} \left( 2\chi^4\text{Area} - \chi^4 y + 2\chi^4 + 36\chi^3\text{Area} - 18\chi^3 y - 16\chi^3 s - 60\chi^3 + 118\chi^2\text{Area} \right. \\
 &\quad \left. - 59\chi^2 y - 192\chi^2 s - 1610\chi^2 + 84\chi\text{Area} - 42\chi y - 368\chi s - 5580\chi - 96s - 4032 \right) x^4 \\
 &+ o(x^4).
 \end{aligned}$$

For Hirzebruch surfaces  $\mathbb{F}_n$  the Euler characteristic is  $\chi(\mathbb{F}_n) = 4$ , hence

$$\begin{aligned}
 AR_{1,s}^{\mathcal{F}_n} &= \left( \text{Area} - \frac{1}{2}y + 1 \right) + (4\text{Area} - 2y - 2s - 8)x + (14\text{Area} - 7y - 10s - 70)x^2 \\
 &+ (40\text{Area} - 20y - 38s - 320)x^3 + \left( 105\text{Area} - \frac{105}{2}y - 118s - 1155 \right) x^4 \pmod{x^5}.
 \end{aligned}$$

# Generating series at fixed codegree

---

In the previous chapters, we fixed the genus and looked at the generating series over the (co)degree, i.e. we computed

$$AR_{g,s}^{\mathcal{F}} = \sum_{i \geq 0} (AR_{g,s}^{\mathcal{F}})_i x^i$$

for  $g = 0, 1$ . In this chapter we adopt the dual point of view. We look at the generating series in the genus parameter at fixed (co)degree, i.e. we wish to determine

$$\sum_{g \geq 0} (AR_{g,s}^{\mathcal{F}})_i u^g$$

for some values of  $i$ . The case  $i = 0$  amounts to compute the leading coefficient of the tropical refined invariant, which was already known from [IM13]. The main contribution is theorem 6.3.1, which gives a closed formula for  $i = 1$ . To do so, we compute the degree 1 term of  $G_g^*(\Delta, s)$  and sum over  $g$ .

This chapter is based on [BM24]. However, compared to [BM24] we consider here higher genus Göttsche-Schroeter invariants, as defined in chapter 3, i.e. we work with non-zero  $s$ . Again, we use the pairing  $S = \{\{1, 2\}, \dots, \{2s, 2s - 1\}\}$  of order  $s$ .

## 6.1 Reminder on diagrams of codegree 0

Recall from proposition 2.2.24 that a diagram  $\mathcal{D}$  has codegree 0 if and only if the order is total on its floors, it has no side edge (i.e. a bounded edge adjacent to non-consecutive floors), the functions  $L$  and  $R$  are increasing and the infinite edges are adjacent to the extremal vertices. Since we look at floor diagrams of small codegree, we will assume that the polygons  $\Delta$  are large enough, in particular  $e^{-\infty}(\Delta) \geq i + 2s$ . By lemmas of section 2.2.3 we can also assume that the diagrams have a total order on their vertices, and we can control the number of side edges as well as the monotonicity of the functions  $L$  and  $R$ .

In all this chapter, for  $\mathcal{F}$  an  $h$ -transverse fan and  $\Delta \in D(\mathcal{F})$  a polygon, we will refer as  $\mathcal{D}_0$  to be the floor diagram of figure 6.1. It is the unique diagram of Newton polygon  $\Delta$ , genus 0 and codegree 0. We denote by  $w_k$  the weight of the edge between the floors  $v_k$  and  $v_{k+1}$  for

$1 \leq k \leq a - 1$ . Note that

$$\deg(\mathcal{D}_0) = \sum_{k=1}^{a-1} (w_k - 1) = g_{\max}(\Delta).$$

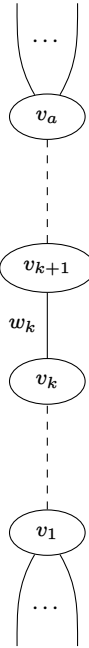

Figure 6.1 – The diagram  $\mathcal{D}_0$ .

## 6.2 Degree 0 terms

We start by computing  $(AR_{g,s}^{\mathcal{F}})_0$ , the constant term of the asymptotic refined invariant. This amounts to compute the leading coefficient of the higher genus Göttsche-Schroeter invariant, which was already handled in [IM13, proposition 2.11] using the lattice path algorithm from [Mik05]. We recall a proof here, because it uses a construction starting from  $\mathcal{D}_0$  that will appear several times in section 6.3.

**Proposition 6.2.1 ([IM13]).** *Let  $\mathcal{F}$  be an  $h$ -transverse fan. The generating series in the genus parameter of the constant term of the asymptotic refined invariant is given by*

$$\sum_{g \geq 0} (AR_{g,s}^{\mathcal{F}})_0 u^g = (1 + u)^{g_{\max}}.$$

*Proof.* To construct a marked floor diagram of positive genus and codegree 0, we add  $g_k$  edges between the floors  $v_k$  and  $v_{k+1}$  of  $\mathcal{D}_0$ , mark the new edges increasingly from left to right, and split the weight  $w_k$  onto the  $g_k + 1$  edges. The genus of the new diagram is  $g_1 + \dots + g_{a-1}$ , and the marking is compatible with  $S$ . For each  $k$  there are  $\binom{w_k-1}{g_k}$  tuples of  $g_k + 1$  positive integers

with sum  $w_k$ , i.e. ways to distribute  $w_k$  onto the marked edges. Since we only care about the number of compatible marked diagrams of genus  $g$  to compute  $(AR_{g,s}^{\mathcal{F}})_0$ , using the binomial formula one has

$$\begin{aligned} \sum_{g \geq 0} (AR_{g,s}^{\mathcal{F}})_0 u^g &= \sum_{g_1, \dots, g_{a-1} \geq 0} u^{g_1 + \dots + g_{a-1}} \prod_{k=1}^{a-1} \binom{w_k - 1}{g_k} \\ &= \prod_{k=1}^{a-1} \sum_{g_k \geq 0} \binom{w_k - 1}{g_k} u^{g_k} \\ &= \prod_{k=1}^{a-1} (1 + u)^{w_k - 1} = (1 + u)^{g_{\max}}. \end{aligned}$$

□

*Remark 6.2.2.* It is not a surprise that this does not depend on  $s$ . Another proof, more complicated, that the constant term is  $(g_{\max})$  is given in theorem 3.1.8.

### 6.3 Degree 1 terms

We now compute the generating series of the degree 1 terms.

**Theorem 6.3.1.** *Let  $\mathcal{F}$  be an  $h$ -transverse, horizontal and non-singular fan. The generating series of the degree 1 terms of the asymptotic refined invariant is given by*

$$\sum_{g \geq 0} (AR_{g,s}^{\mathcal{F}})_1 u^g = (1 + u)^{g_{\max}} \left[ (\chi + 2su) \frac{1}{1 + u} - (u\mathcal{L} - K)^2 \frac{u}{(1 + u)^3} \right]$$

where  $\mathcal{L} : \Delta \mapsto \mathcal{L}_{\Delta}$  and  $K : \Delta \mapsto K_{X_{\Delta}}$ . In particular, the asymptotic polynomials yielding the degree 1 coefficients are polynomials in  $\mathcal{L}_{\Delta}^2$ ,  $y(\Delta) = -K_{X_{\Delta}} \cdot \mathcal{L}_{\Delta}$ ,  $\chi(\Delta)$ ,  $K_{X_{\Delta}}^2$  and  $s$ .

Given that the multiplicity takes the form

$$\mu_S^*(\mathcal{D}) = x^{\text{codeg}(\mathcal{D})} (1 - x)^{e^{\infty}(\mathcal{D})} \left( \frac{1 + x}{1 - x} \right)^s \prod_{e \in E^0(\mathcal{D})} (1 - x^{w(e)})^2,$$

only diagrams with codegree 0 and 1 contribute to  $\sum_g (AR_{g,s}^{\mathcal{F}})_1 u^g$ . We subdivide the proof of theorem 6.3.1 in four lemmas, each one computing the contribution of a specific family of diagrams to the global sum. To get theorem 6.3.1, we sum the expressions from lemmas 6.3.2, 6.3.3, 6.3.4 and 6.3.5. In all these lemmas we consider a polygon  $\Delta \in D(\mathcal{F})$  large enough. We use the shortcuts  $g_{\max} = g_{\max}(\Delta)$ ,  $e^{\infty} = e^{\infty}(\Delta)$ , etc.



**Lemma 6.3.2.** *The codegree 0 diagrams with Newton polygon  $\Delta$  contribute*

$$(1+u)^{g_{\max}} \left[ -e^\infty + 2s - 2g_{\max} \frac{u^2}{(1+u)^2} - 2(a-1) \frac{u(2+u)}{(1+u)^2} \right].$$

*Proof.* We construct a diagram of genus  $g$  and codegree 0 as in the proof of proposition 6.2.1. A diagram  $\mathcal{D}$  of codegree 0 is counted with the degree 1 term of its multiplicity, that is

$$-e^\infty + 2s - 2|\{e \in E^0(\mathcal{D}) \mid w(e) = 1\}|.$$

Hence, the contribution to  $\sum_g (AR_{g,s}^f)_1 u^g$  coming from the first term is

$$(-e^\infty + 2s)(1+u)^{g_{\max}}.$$

We now compute the contribution coming from the second term, i.e. we enumerate the choices of a diagram together with an edge of weight 1. To determine this contribution, we proceed as previously but for any fixed  $k$ , we assume one of the  $g_k + 1$  edges between  $v_k$  and  $v_{k+1}$  has weight 1, and it remains a weight  $w_k - 1$  to split into  $g_k$  parts. Forgetting the factor  $-2$ , this gives

$$\begin{aligned} & \sum_{k=1}^{a-1} \left( \sum_{\substack{g_j \geq 0 \\ j \neq k}} \prod_{j \neq k} \binom{w_j - 1}{g_j} u^{g_j} \right) \left( \sum_{g_k \geq 0} \sum_{\substack{\text{edges} \\ v_k \rightarrow v_{k+1}}} \binom{w_k - 2}{g_k - 1} u^{g_k} \right) \\ &= \sum_{k=1}^{a-1} (1+u)^{\sum_{j \neq k} (w_j - 1)} \sum_{g_k \geq 0} (g_k + 1) \binom{w_k - 2}{g_k - 1} u^{g_k} \\ &= \sum_{k=1}^{a-1} (1+u)^{g_{\max} - (w_k - 1)} \left[ (w_k - 2)u^2(1+u)^{w_k - 3} + 2u(1+u)^{w_k - 2} \right] \\ &= (1+u)^{g_{\max}} \left[ g_{\max} \frac{u^2}{(1+u)^2} + (a-1) \frac{u(2+u)}{(1+u)^2} \right]. \end{aligned}$$

□

We now look at the diagrams of codegree 1. The degree 1 term of the multiplicity of a diagram of codegree 1 is 1, so it suffices to determine their number. There are two possibilities for the codegree being 1 : the presence of a side edge, i.e. an edge bypassing a floor, or a slope inversion, i.e. a lack of growth of the divergence function. We investigate all the cases.

**Lemma 6.3.3.** *The codegree 1 diagrams with Newton polygon  $\Delta$  and an infinite side edge contribute*

$$(1+u)^{g_{\max}} \left[ (w_1 + w_{a-1} - 2) \frac{u}{(1+u)^2} + (e^\infty - 2s) \frac{1}{1+u} + 2 \frac{2+u}{(1+u)^2} \right].$$

*Proof.* We first deal with the case when the side edge is a source.

Let  $\mathcal{D}_{\text{bot}}$  be the diagram of figure 6.2a. It is obtained from  $\mathcal{D}_0$  by putting a source adjacent to  $v_2$ . It has genus 0 and codegree 1. Let  $\tilde{w}_k$  be the weight of the edge between  $v_k$  and  $v_{k+1}$  for  $1 \leq k \leq a-1$ . One has

$$\tilde{w}_1 = w_1 - 1 \text{ and } \tilde{w}_k = w_k \text{ for } k \in \{2, \dots, a-1\}.$$

To create a diagram of higher genus, as in theorem 6.2.1 we add  $g_k$  edges between the floor  $v_k$  and  $v_{k+1}$  of  $\mathcal{D}_{\text{bot}}$ , mark the new edges increasingly from left to right, and split the weight  $\tilde{w}_k$  onto the  $g_k + 1$  edges. The genus of the new diagram is  $g_1 + \dots + g_{a-1}$ , and for each  $k$  there are  $\binom{\tilde{w}_k - 1}{g_k}$  ways to distribute  $\tilde{w}_k$  onto the marked edges. To entirely determine the marked floor diagram, it remains to mark the side edge. It is parallel to  $(g_1 + 1) + (e^{-\infty} - 1)$  edges and 1 floor, hence there are  $g_1 + e^{-\infty} + 2$  possibilities for its marking. However,  $2s$  of them are incompatible with  $S$ . In the end, this case contributes

$$\begin{aligned} & \sum_{g_1, \dots, g_{a-1} \geq 0} (g_1 + e^{-\infty} + 2 - 2s) \prod_{k=1}^{a-1} \binom{\tilde{w}_k - 1}{g_k} u^{g_k} \\ &= (1 + u)^{g_{\max} - (w_1 - 1)} \sum_{g_1 \geq 0} (g_1 + e^{-\infty} + 2 - 2s) \binom{\tilde{w}_1 - 1}{g_1} u^{g_1} \\ &= (1 + u)^{g_{\max} - (w_1 - 1)} \left[ (\tilde{w}_1 - 1)u(1 + u)^{\tilde{w}_1 - 2} + (e^{-\infty} + 2 - 2s)(1 + u)^{\tilde{w}_1 - 1} \right] \\ &= (1 + u)^{g_{\max}} \left[ (w_1 - 1) \frac{u}{(1 + u)^2} + (e^{-\infty} - 2s) \frac{1}{1 + u} + \frac{2 + u}{(1 + u)^2} \right]. \end{aligned}$$

If the side edge is a sink, by symmetry and considering  $s = 0$  we get

$$(1 + u)^{g_{\max}} \left[ (w_{a-1} - 1) \frac{u}{(1 + u)^2} + e^{+\infty} \frac{1}{1 + u} + \frac{2 + u}{(1 + u)^2} \right].$$

We obtain the result summing the two cases.  $\square$

**Lemma 6.3.4.** *The codegree 1 diagrams with Newton polygon  $\Delta$  and a bounded side edge contribute*

$$(1 + u)^{g_{\max}} \left[ \sum_{j=1}^{a-2} (w_j + w_{j+1} - 2) \frac{u^2}{(1 + u)^3} + 2(a - 2) \frac{u(2 + u)}{(1 + u)^3} \right].$$

*Proof.* Start with the diagram  $\mathcal{D}_j$  of figure 6.2b. It has genus 1 and a side edge of weight 1 between  $v_j$  and  $v_{j+2}$ . Let  $\tilde{w}_k$  be the weight of the edge between  $v_k$  and  $v_{k+1}$  for  $1 \leq k \leq a-1$ . One has

$$\tilde{w}_j = w_j - 1, \tilde{w}_{j+1} = w_{j+1} - 1 \text{ and } \tilde{w}_k = w_k \text{ for } k \notin \{j, j+1\}.$$

As previously, we add  $g_k$  edges between the floor  $v_k$  and  $v_{k+1}$  of  $\mathcal{D}_{\text{bot}}$ , mark the new edges increasingly from left to right, and split the weight  $w_k$  onto the  $g_k + 1$  edges. The created

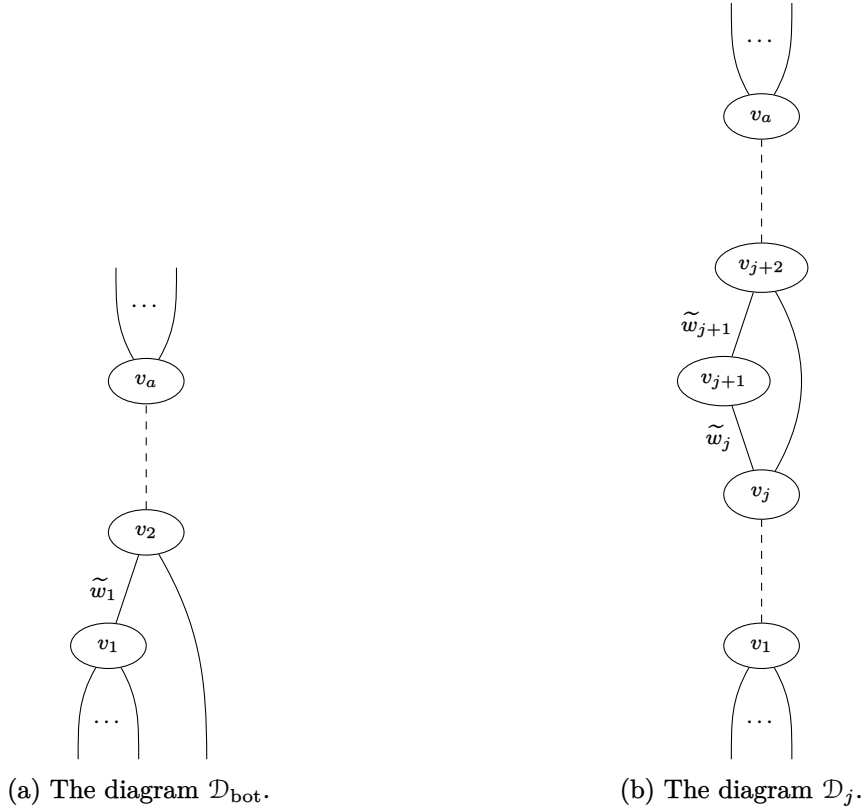

Figure 6.2

diagram has genus  $1 + g_1 + \dots + g_{a-1}$ , and its marking is compatible with  $S$ . The side edge is parallel to 1 floor and  $g_j + g_{j+1} + 2$  edges, so there are  $g_j + g_{j+1} + 4$  possibilities for its marking. Hence, the contribution in that case is

$$\begin{aligned}
 & u \sum_{j=1}^{a-2} \sum_{g_1, \dots, g_{a-1} \geq 0} (g_j + g_{j+1} + 4) \prod_{k=1}^{a-1} \binom{\tilde{w}_k - 1}{g_k} u^{g_k} \\
 &= \sum_{j=1}^{a-2} (\tilde{w}_j + \tilde{w}_{j+1} - 2) u^2 (1 + u)^{g_{\max} - 3} + 4(a - 2) u (1 + u)^{g_{\max} - 2} \\
 &= (1 + u)^{g_{\max}} \left[ \sum_{j=1}^{a-2} (w_j + w_{j+1} - 2) \frac{u^2}{(1 + u)^3} + 2(a - 2) \frac{u(2 + u)}{(1 + u)^3} \right]. \quad \square
 \end{aligned}$$

**Lemma 6.3.5.** *The codegree 1 diagrams with an slope inversion contribute*

$$(\chi - 4)(1 + u)^{g_{\max} - 1}.$$

*Proof.* To get a floor diagram of codegree 1 with an inversion, the only possibility is the existence of a unique couple  $(v, v')$  of adjacent floors such that  $v \prec v'$  and  $R(v) = R(v') + 1$  (or  $L(v) =$

$L(v') + 1$ ), and anywhere else in the floor diagram  $R$  and  $L$  are increasing. There are  $\chi - 4$  possible such pairs, one for each corner of  $\Delta$  non-adjacent to a horizontal side. If  $v = v_k$  (and so  $v' = v_{k+1}$ ), then the only difference with the codegree 0 diagram from figure 6.1 is that the weight between  $v_k$  and  $v_{k+1}$  is  $w_k - 1$  so that the sum of weights yields  $g_{\max} - 1$  instead of  $g_{\max}$ . In the end, this case contributes

$$(\chi - 4)(1 + u)^{g_{\max} - 1}.$$

□

*Proof of theorem 6.3.1.* Summing the contributions of the previous lemmas we get

$$(1 + u)^{g_{\max} - 3} \left[ (2s - e^\infty - 2g_{\max} - 2a + 2)u^3 + \chi(1 + u)^2 \right. \\ \left. \left( 4s - 2e^\infty - 2g_{\max} - 4a + 2 \sum_{k=1}^{a-1} (w_k - 1) \right) u^2 + (2s - e^\infty - 8 + w_1 + w_{a-1})u \right].$$

By the adjunction (or Pick's) formula one has  $2g_{\max} = \mathcal{L}^2 - y + 2$  where  $y = 2a + e^\infty$ . Hence the coefficient of the  $u^3$  term is  $2s - \mathcal{L}^2$ . Using the relation  $g_{\max} = \sum_k (w_k - 1)$ , the coefficient of the  $u^2$  term is  $4s - 2y$ . Last, one has

$$w_1 + w_{a-1} = e^\infty + \max(\text{div}) - \min(\text{div}) = e^\infty + \chi - 4$$

by lemma 5.3.4. Coupled with Noether's formula  $\chi = 12 - K^2$ , the coefficient of the  $u$  term is  $2s - K^2$ . In the end, one has

$$\sum_{g \geq 0} (AR_{g,s}^{\mathcal{F}})_1 u^g \\ = (1 + u)^{g_{\max}} \left[ (2s - \mathcal{L}^2) \frac{u^3}{(1 + u)^3} + (4s - 2y) \frac{u^2}{(1 + u)^3} + \chi \frac{1}{1 + u} + (2s - K^2) \frac{u}{(1 + u)^3} \right].$$

Gathering the terms with  $s$  then simplifying we get

$$\sum_{g \geq 0} (AR_{g,s}^{\mathcal{F}})_1 u^g = (1 + u)^{g_{\max}} \left[ (\chi + 2su) \frac{1}{1 + u} - \mathcal{L}^2 \frac{u^3}{(1 + u)^3} - 2y \frac{u^2}{(1 + u)^3} - K^2 \frac{u}{(1 + u)^3} \right] \\ = (1 + u)^{g_{\max}} \left[ (\chi + 2su) \frac{1}{1 + u} - (u\mathcal{L} - K)^2 \frac{u}{(1 + u)^3} \right].$$

□

*Remark 6.3.6.* If we do not assume the fan to be non-singular, the equality

$$w_1 + w_{a-1} = e^\infty + \max(\text{div}) - \min(\text{div}) = e^\infty + \chi - 4$$

obtained by lemma 5.3.4 becomes

$$w_1 + w_{a-1} = e^\infty + \max(\text{div}) - \min(\text{div}) = e^\infty + \sum_{k \geq 0} kn_k - 4,$$

see remark 5.3.6. Moreover, the factor  $\chi - 4$  in lemma 6.3.5 is replaced by  $n_1 - 4$ . Indeed, only the vertices of index 1 can contribute to the degree 1 term of the asymptotic refined invariant. There are  $n_1$  such vertices, but 4 of them are the vertices adjacent to the horizontal sides of the polygon, hence they do not contribute. Thus for an  $h$ -transverse and horizontal fan  $\mathcal{F}$  one has

$$\begin{aligned} & \sum_{g \geq 0} (AR_{g,s}^{\mathcal{F}})_1 u^g \\ &= (1+u)^{g_{\max}} \left[ (n_1 + 2su) \frac{1}{1+u} - \mathcal{L}^2 \frac{u^3}{(1+u)^3} - 2y \frac{u^2}{(1+u)^3} + \left( \sum_{k \geq 0} kn_k - 12 \right) \frac{u}{(1+u)^3} \right]. \end{aligned}$$

*Example 6.3.7.* Take  $g = 2$  and let  $\mathcal{F}$  be an  $h$ -transverse, horizontal and non-singular fan. By proposition 6.2.1, the constant term of  $AR_{g,s}^{\mathcal{F}}$  is  $\binom{g_{\max}}{2}$ . By theorem 6.3.1, the degree 1 term is

$$\begin{aligned} & \binom{g_{\max}}{2} + g_{\max}(-\chi + 2s - K_{X_\Delta}^2) + (4s - 2y + \chi - 6s + 3K_{X_\Delta}^2) \\ &= \binom{g_{\max}}{2} + (g_{\max} - 1)(2s - \chi) - (g_{\max} - 3)K_{X_\Delta}^2 - 2y. \end{aligned}$$

In light of conjecture 5.3.8, if we set

$$\begin{aligned} Q_2^{\mathcal{F}}(\Delta, s)(x) &= \left( (1 - \chi(X_{\mathcal{F}})) \binom{g_{\max}}{2} + (g_{\max} - 1)(2s - \chi(X_{\mathcal{F}})) - (g_{\max} - 3)K_{X_{\mathcal{F}}}^2 - 2y \right) x \\ &= \left( (K_{X_{\mathcal{F}}}^2 - 11) \binom{g_{\max}}{2} + (g_{\max} - 1)(2s + K_{X_{\mathcal{F}}}^2 - 12) - (g_{\max} - 3)K_{X_{\mathcal{F}}}^2 - 2y \right) x \end{aligned}$$

then  $Q_2^{\mathcal{F}}$  is a polynomial of degree 2 in  $g_{\max}(\Delta)$ ,  $y(\Delta)$  and  $s$ , i.e. in  $\mathcal{L}_\Delta^2$ ,  $y(\Delta)$  and  $s$ , whose coefficients are polynomial in  $x$ , and one has

$$AR_{2,s}^{\mathcal{F}}(\Delta)(x) = P(x)^{\chi(X_{\mathcal{F}})} \left( \binom{g_{\max}(\Delta)}{2} + Q_2^{\mathcal{F}}(\Delta, s)(x) \right) \pmod{x^2}.$$

# Bibliography

---

- [AB01] Dan Abramovich and Aaron Bertram, « The formula  $12 = 10 + 2 \times 1$  and its generalizations: counting rational curves on  $\mathbb{F}_2$  ». *Advances in algebraic geometry motivated by physics (Lowell, MA, 2000)*, *Contemp. Math.*, **276**, (2001), pp. 83–88.
- [AB13] Federico Ardila and Florian Block, « Universal polynomials for Severi degrees of toric surfaces ». *Advances in Mathematics*, **237**, (2013), pp. 165–193, DOI: [10.1016/j.aim.2013.01.002](https://doi.org/10.1016/j.aim.2013.01.002).
- [ABLdM10] Aubin Arroyo, Erwan Brugallé and Lucía López de Medrano, « Recursive formulas for Welschinger invariants of the projective plane ». *International Mathematics Research Notices*, **2011(5)**, (2010), pp. 1107–1134, DOI: [10.1093/imrn/rnq096](https://doi.org/10.1093/imrn/rnq096).
- [BCK14] Florian Block, Susan Jane Colley and Gary Kennedy, « Computing Severi degrees with long-edge graphs ». *Bulletin of the Brazilian Mathematical Society, New Series*, **45(4)**, (2014), pp. 625–647, DOI: [10.1007/s00574-014-0066-6](https://doi.org/10.1007/s00574-014-0066-6).
- [BG16a] Florian Block and Lothar Göttsche, « Fock spaces and refined Severi degrees ». *International Mathematics Research Notices*, **2016(21)**, (2016), pp. 6553–6580, DOI: [10.1093/imrn/rnv355](https://doi.org/10.1093/imrn/rnv355).
- [BG16b] Florian Block and Lothar Göttsche, « Refined curve counting with tropical geometry ». *Compositio Mathematica*, **152(1)**, (2016), pp. 115–151, DOI: [10.1112/S0010437X1500754X](https://doi.org/10.1112/S0010437X1500754X).
- [BJP22] Erwan Brugallé and Andrés Jaramillo-Puentes, « Polynomiality properties of tropical refined invariants ». *Combinatorial Theory*, **2(2)**, DOI: [10.5070/C62257845](https://doi.org/10.5070/C62257845).
- [Blo11] Florian Block, « Computing node polynomials for plane curves ». *Mathematical Research Letters*, **18(4)**, (2011), pp. 621–643, DOI: [10.4310/MRL.2011.v18.n4.a4](https://doi.org/10.4310/MRL.2011.v18.n4.a4).
- [Blo23] Thomas Blomme, « Refined count of oriented real rational curves ». *Journal of Algebraic Geometry*, DOI: [10.1090/jag/801](https://doi.org/10.1090/jag/801).
- [BM07] Erwan Brugallé and Grigory Mikhalkin, « Enumeration of curves via floor diagrams ». *Comptes Rendus Mathématiques de l'Académie des Sciences de Paris*, **345(6)**, (2007), pp. 329–334, DOI: [10.1016/j.crma.2007.07.026](https://doi.org/10.1016/j.crma.2007.07.026).
- [BM08] Erwan Brugallé and Grigory Mikhalkin, « Floor decompositions of tropical curves : the planar case ». *Proceedings of 15th Gökova Geometry-Topology Conference*, pp. 64–90.

- [BM16] Erwan Brugallé and Hannah Markwig, « Deformation of tropical Hirzebruch surfaces and enumerative geometry ». *Journal of Algebraic Geometry*, **25**, (2016), pp. 633–702, DOI: [10.1090/jag/671](https://doi.org/10.1090/jag/671).
- [BM24] Thomas Blomme and Gurvan Mével, « Asymptotic computations of tropical refined invariants in genus 0 and 1 ». *arxiv:2403.17474*.
- [Bou19] Pierrick Bousseau, « Tropical refined curve counting from higher genera and lambda classes ». *Invent. math.*, **215**, (2019), pp. 1 – 79, DOI: [10.1007/s00222-018-0823-z](https://doi.org/10.1007/s00222-018-0823-z).
- [Bou21] Pierrick Bousseau, « Refined floor diagrams from higher genera and lambda classes ». *Selecta Mathematica*, **27(43)**, DOI: [10.1007/s00029-021-00667-w](https://doi.org/10.1007/s00029-021-00667-w).
- [BP15] Erwan Brugallé and Nicolas Puignaux, « On Welschinger invariants of symplectic 4-manifolds ». *Comment. Math. Helv.*, **90(4)**, (2015), pp. 905–938, DOI: [10.4171/CMH/373](https://doi.org/10.4171/CMH/373).
- [Bru08] Erwan Brugallé, « Géométries énumératives complexe, réelle et tropicale ». In *Géométrie tropicale* (edited by Pascale Harinck, Alain Plagne and Claude Sabbah), pp. 27–84, Éd. de l'École Polytechnique, Palaiseau (2008).
- [Bru20] Erwan Brugallé, « On the invariance of Welschinger invariants ». *Algebra i Analiz*, **32(2)**, (2020), pp. 1–20, DOI: [10.1090/spmj/1644](https://doi.org/10.1090/spmj/1644).
- [BS19] Lev Blechman and Eugeni Shustin, « Refined descendant invariants of toric surfaces ». *Discrete & Computational Geometry*, **62**, (2019), pp. 180–208, DOI: [10.1007/s00454-019-00093-y](https://doi.org/10.1007/s00454-019-00093-y).
- [CCC23] Linda Carey, Louise Carey and Mike Carey, *La Cité de Soie et d'Acier. L'Atalante* (2023). Traduit par Mathilde Montier.
- [CH98] Lucia Caporaso and Joe Harris, « Counting plane curves of any genus ». *Inventiones mathematicae*, **131(2)**, (1998), pp. 345–392, DOI: [10.1007/s002220050208](https://doi.org/10.1007/s002220050208).
- [CLS11] David A. Cox, John B. Little and Henry K. Schenck, *Toric varieties*. Graduate Studies in Mathematics 124, American Mathematical Society (2011), DOI: [10.1090/gsm/124](https://doi.org/10.1090/gsm/124).
- [DFI95] Philippe Di Francesco and Claude Itzykson, « Quantum intersection rings ». In *The Moduli Space of Curves*, pp. 81–148, Birkhäuser Boston, Boston, MA (1995), DOI: [10.1007/978-1-4612-4264-2\\_4](https://doi.org/10.1007/978-1-4612-4264-2_4).
- [DK00] Alexander Degtyarev and Viatcheslav Kharlamov, « Topological properties of real algebraic varieties : Rokhlin's way ». *Russian Mathematical Surveys*, **55(4)**, (2000), pp. 735–814, DOI: [10.1070/RM2000v055n04ABEH000315](https://doi.org/10.1070/RM2000v055n04ABEH000315).

- [FM10] Sergey Fomin and Grigory Mikhalkin, « Labeled floor diagrams for plane curves ». *Journal of the European Mathematical Society*, pp. 1453–1496, DOI: [10.4171/JEMS/238](https://doi.org/10.4171/JEMS/238).
- [FM11] Marina Franz and Hannah Markwig, « Tropical enumerative invariants of  $\mathbb{F}_0$  and  $\mathbb{F}_2$  ». *Advances in Geometry*, **11(1)**, (2011), pp. 49–72, DOI: [10.1515/ADVGEOM.2010.038](https://doi.org/10.1515/ADVGEOM.2010.038).
- [Ful93] William Fulton, *Introduction to toric varieties*. Annals of Mathematics Studies 131, Princeton University Press (1993), DOI: [10.1515/9781400882526](https://doi.org/10.1515/9781400882526).
- [GH94] Phillip Griffiths and Joseph Harris, *Principles of Algebraic Geometry*. Wiley Classics Library, John Wiley & Sons, Inc. (1994), DOI: [10.1002/9781118032527](https://doi.org/10.1002/9781118032527).
- [GKP94] Ronald Lewis Graham, Donald Ervin Knuth and Oren Patashnik, *Concrete mathematics: a foundation for computer science*. Addison-Wesley, Reading, Mass, 2nd edition (1994).
- [GKZ94] Israel M. Gelfand, Mikhail M. Kapranov and Andrei V. Zelevinsky, *Discriminants, Resultants, and Multidimensional Determinants*. Birkhäuser Boston, Boston, MA (1994), DOI: [10.1007/978-0-8176-4771-1](https://doi.org/10.1007/978-0-8176-4771-1).
- [GM07a] Andreas Gathmann and Hannah Markwig, « The Caporaso-Harris formula and plane relative Gromov-Witten invariants in tropical geometry ». *Mathematische Annalen*, **338**, (2007), pp. 845–868, DOI: [10.1007/s00208-007-0092-4](https://doi.org/10.1007/s00208-007-0092-4).
- [GM07b] Andreas Gathmann and Hannah Markwig, « The numbers of tropical plane curves through points in general position ». *Journal für die reine und angewandte Mathematik (Crelle's Journal)*, **2007(602)**, (2007), pp. 155–177, DOI: [10.1515/crelle.2007.006](https://doi.org/10.1515/crelle.2007.006).
- [GM08] Andreas Gathmann and Hannah Markwig, « Kontsevich's formula and the WDVV equations in tropical geometry ». *Advances in Mathematics*, **217(2)**, (2008), pp. 537–560, DOI: [10.1016/j.aim.2007.08.004](https://doi.org/10.1016/j.aim.2007.08.004).
- [GMS13] Andreas Gathmann, Hannah Markwig and Franziska Schroeter, « Broccoli curves and the tropical invariance of Welschinger numbers ». *Advances in Mathematics*, **240**, (2013), pp. 520–574, DOI: [10.1016/j.aim.2013.03.004](https://doi.org/10.1016/j.aim.2013.03.004).
- [Göt98] Lothar Göttsche, « A conjectural generating function for numbers of curves on surfaces ». *Communications in Mathematical Physics*, **196(3)**, (1998), pp. 523–533, DOI: [10.1007/s002200050434](https://doi.org/10.1007/s002200050434).
- [GS14] Lothar Göttsche and Vivek Shende, « Refined curve counting on complex surfaces ». *Geometry & Topology*, **18(4)**, (2014), pp. 2245–2307, DOI: [10.2140/gt.2014.18.2245](https://doi.org/10.2140/gt.2014.18.2245).



- [GS19] Lothar Göttsche and Franziska Schroeter, « Refined broccoli invariants ». *Journal of Algebraic Geometry*, **28(1)**, (2019), pp. 1–41, DOI: [10.1090/jag/705](https://doi.org/10.1090/jag/705).
- [IKS03] Ilia Itenberg, Viatcheslav Kharlamov and Eugenio Shustin, « Welschinger invariant and enumeration of real rational curves ». *International Mathematics Research Notices*, **2003(49)**, (2003), pp. 2639–2653, DOI: [10.1155/S1073792803131352](https://doi.org/10.1155/S1073792803131352).
- [IKS04] Ilia Itenberg, Viatcheslav Kharlamov and Eugenio Shustin, « Logarithmic equivalence of Welschinger and Gromov-Witten invariants ». *Russian Mathematical Surveys*, **59(6)**, (2004), pp. 1093–1116, DOI: [10.1070/RM2004v059n06ABEH000797](https://doi.org/10.1070/RM2004v059n06ABEH000797).
- [IKS09] Ilia Itenberg, Viatcheslav Kharlamov and Eugenio Shustin, « A Caporaso-Harris type formula for Welschinger invariants of real toric del Pezzo surfaces ». *Commentarii Mathematici Helvetici*, **84**, (2009), pp. 87–126, DOI: [10.5169/seals-99111](https://doi.org/10.5169/seals-99111).
- [IM13] Ilia Itenberg and Grigory Mikhalkin, « On Block–Göttsche multiplicities for planar tropical curves ». *International Mathematics Research Notices*, **2013(23)**, (2013), pp. 5289–5320, DOI: [10.1093/imrn/rns207](https://doi.org/10.1093/imrn/rns207).
- [KHSUK23] Patrick Kennedy-Hunt, Qaasim Shafi and Ajith Urundolil Kumaran, « Tropical refined curve counting with descendants ». *arXiv:2307.09436*.
- [KM94] Maxim Kontsevich and Yu Manin, « Gromov-Witten classes, quantum cohomology, and enumerative geometry ». *Communications in Mathematical Physics*, **164(3)**, (1994), pp. 525–562, DOI: [10.1007/BF02101490](https://doi.org/10.1007/BF02101490).
- [KP04] Steven Lawrence Kleiman and Ragni Piene, « Node polynomials for families: methods and applications ». *Mathematische Nachrichten*, **271**, (2004), pp. 69–90, DOI: [10.1002/mana.200310182](https://doi.org/10.1002/mana.200310182).
- [KST11] Martijn Kool, Vivek Shende and Richard Thomas, « A short proof of the Göttsche conjecture ». *Geometry & Topology*, **15(1)**, (2011), pp. 397–406, DOI: [10.2140/gt.2011.15.397](https://doi.org/10.2140/gt.2011.15.397).
- [Liu16] Fu Liu, « A combinatorial analysis of Severi degrees ». *Advances in Mathematics*, **298**, (2016), pp. 1–50, DOI: [10.1016/j.aim.2016.04.011](https://doi.org/10.1016/j.aim.2016.04.011).
- [LO18] Fu Liu and Brian Osserman, « Severi degrees on toric surfaces ». *Journal für die reine und angewandte Mathematik (Crelle's Journal)*, **2018(739)**, (2018), pp. 121–158, DOI: [10.1515/crelle-2015-0059](https://doi.org/10.1515/crelle-2015-0059).
- [Mév23] Gurvan Mével, « Universal polynomials for tropical refined invariants in genus 0 ». *arXiv:2312.16871*.
- [Mik05] Grigory Mikhalkin, « Enumerative tropical algebraic geometry in  $\mathbb{R}^2$  ». *Journal of the American Mathematical Society*, **18(2)**, (2005), pp. 313–377, DOI: [10.1090/S0894-0347-05-00477-7](https://doi.org/10.1090/S0894-0347-05-00477-7).

- [Mik17] Grigory Mikhalkin, « Quantum indices and refined enumeration of real plane curves ». *Acta Mathematica*, **219(1)**, (2017), pp. 135 – 180, DOI: [10.4310/ACTA.2017.v219.n1.a5](https://doi.org/10.4310/ACTA.2017.v219.n1.a5).
- [NPS18] Johannes Nicaise, Sam Payne and Franziska Schroeter, « Tropical refined curve counting via motivic integration ». *Geometry & Topology*, **22**, (2018), pp. 3175–3234, DOI: [10.2140/gt.2018.22.3175](https://doi.org/10.2140/gt.2018.22.3175).
- [Sha13] Igor R. Shafarevich, *Basic Algebraic Geometry 2*. Springer, Berlin, Heidelberg, 3rd edition (2013), DOI: [10.1007/978-3-642-38010-5](https://doi.org/10.1007/978-3-642-38010-5).
- [Shu06] Eugenii Shustin, « A tropical calculation of the Welschinger invariants of real toric del Pezzo surfaces ». *Journal of Algebraic Geometry*, **15**, (2006), pp. 285–322, DOI: [10.1090/S1056-3911-06-00434-6](https://doi.org/10.1090/S1056-3911-06-00434-6).
- [SS18] Franziska Schroeter and Eugenii Shustin, « Refined elliptic tropical enumerative invariants ». *Israel Journal of Mathematics*, **225(2)**, (2018), pp. 817–869, DOI: [10.1007/s11856-018-1680-6](https://doi.org/10.1007/s11856-018-1680-6).
- [SS24] Eugenii Shustin and Uriel Sinichkin, « Refined tropical invariants and characteristic numbers ». *arxiv:2408.08420*.
- [Tol12] John Ronald Reuel Tolkien, *Le Seigneur des Anneaux - Intégrale*. Pocket (2012). Traduit par Francis Ledoux.
- [Tze12] Yu-jong Tzeng, « A proof of the Göttsche-Yau-Zaslow formula ». *Journal of Differential Geometry*, **90**, (2012), pp. 439–472, DOI: [10.4310/jdg/1335273391](https://doi.org/10.4310/jdg/1335273391).
- [Vai95] Israel Vainsencher, « Enumeration of  $n$ -fold tangent hyperplanes to a surface ». *Journal of Algebraic Geometry*, **4(3)**, (1995), pp. 503–526.
- [Vak00] Ravi Vakil, « Counting curves on rational surfaces ». *Manuscripta Mathematica*, **102**, (2000), pp. 53–84, DOI: [10.1007/s002291020053](https://doi.org/10.1007/s002291020053).
- [Wel05] Jean-Yves Welschinger, « Invariants of real rational symplectic 4-manifolds and lower bounds in real enumerative geometry ». *Inventiones mathematicae*, **162(1)**, (2005), pp. 195–234, DOI: [10.1007/s00222-005-0445-0](https://doi.org/10.1007/s00222-005-0445-0).
- [Zeu73] Hieronymus Georg Zeuthen, « Almindelige egenskaber ved systemer af plane kurver ». *Kongelige Danske Vidensk abernes Selskabs Skrifter - Naturvidenskabelig og Matematisk*, **10**, (1873), pp. 285–393.





**Titre :** Propriétés asymptotiques des invariants tropicaux raffinés

**Mots clés :** Géométrie énumérative, géométrie tropicale, invariants tropicaux raffinés, diagrammes en étages, étude asymptotique, conjecture de Göttsche

**Résumé :** En géométrie algébrique énumérative, le nombre de courbes sur une surface se comporte différemment selon que l'on fixe le nombre de points doubles ou le genre des courbes : polynomial dans le premier cas, il croît plus vite qu'exponentiellement dans le second. Dans le premier cas la conjecture de Göttsche, prouvée par Tzeng, donne une formule universelle pour la série génératrice de ces nombres.

Les invariants tropicaux raffinés ont été introduits par Block et Göttsche. Ce sont des polynômes qui interpolent entre des problèmes énumératifs réels et complexes. Si un comportement polynomial de leurs coefficients est attendu et effectivement observé quand le nombre de points doubles est fixé, Brugallé

et Jaramillo-Puentes ont montré que certains de leurs coefficients varient également polynomialement lorsque le genre est fixé. Cette thèse prouve, dans l'esprit de la conjecture de Göttsche, des formules universelles pour les premiers coefficients des invariants tropicaux raffinés en genre 0 et 1.

Les méthodes utilisées relèvent de la géométrie tropicale. Introduits par Brugallé et Mikhalkin, les diagrammes en étages sont un outil qui transforme la question algébro-géométrique de départ en problème combinatoire. Dans cette thèse, on étudie précisément les diagrammes en étages qui interviennent asymptotiquement dans le calcul des invariants tropicaux raffinés, pour établir des formules universelles.

**Title:** Asymptotic properties of tropical refined invariants

**Keywords:** Enumerative geometry, tropical geometry, tropical refined invariants, floor diagrams, asymptotics, Göttsche conjecture

**Abstract:** In enumerative algebraic geometry, the number of curves on a surface behaves differently whether one fixes the number of nodes or the genus of the curves. It is polynomial in the first case, but grows more than exponentially fast in the second case. In the first case Göttsche conjecture, proven by Tzeng, gives a universal formula for the generating series of these numbers.

Tropical refined invariants were introduced by Block and Göttsche. They are polynomials that interpolate between real and complex enumerative questions. As expected, their coefficients behave polynomially when the number of nodes is fixed. However, Brugallé and

Jaramillo-Puentes proved that some of their coefficients are also polynomial when the genus is fixed. In this thesis we prove some universal formulas for the first coefficients of the tropical refined invariants in genus 0 and 1, in the spirit of Göttsche conjecture.

The techniques we use fall under the scope of tropical geometry. Introduced by Brugallé and Mikhalkin, floor diagrams are a tool that turns the starting algebro-geometric question into a combinatorial problem. In this thesis, we precisely describe the floor diagrams that asymptotically take part in the computation of tropical refined invariants. This allows to write down universal formulas.