



**HAL**  
open science

# Approximation Algorithms for Channel Coding and Non-Signaling Correlations

Paul Fermé

► **To cite this version:**

Paul Fermé. Approximation Algorithms for Channel Coding and Non-Signaling Correlations. Information Theory [cs.IT]. ENS de Lyon, 2023. English. NNT : . tel-04391153

**HAL Id: tel-04391153**

**<https://hal.science/tel-04391153>**

Submitted on 12 Jan 2024

**HAL** is a multi-disciplinary open access archive for the deposit and dissemination of scientific research documents, whether they are published or not. The documents may come from teaching and research institutions in France or abroad, or from public or private research centers.

L'archive ouverte pluridisciplinaire **HAL**, est destinée au dépôt et à la diffusion de documents scientifiques de niveau recherche, publiés ou non, émanant des établissements d'enseignement et de recherche français ou étrangers, des laboratoires publics ou privés.



Distributed under a Creative Commons Attribution 4.0 International License



## THÈSE

en vue de l'obtention du grade de Docteur, délivré par  
l'École Normale Supérieure de Lyon

École Doctorale N°512  
École Doctorale en Informatique et Mathématiques de Lyon

Discipline : Informatique

Soutenue publiquement le 29/11/2023, par :  
**Paul Fermé**

---

# Approximation Algorithms for Channel Coding and Non-Signaling Correlations

Algorithmes d'approximation pour le problème du codage de canal et corrélations non-signalantes

---

Devant le jury composé de :

BERTA Mario, Professeur, RWTH Aachen University (Allemagne)

Rapporteur

ROMASHCHENKO Andrei, Chargé de Recherche-HDR, LIRMM

Rapporteur

GORCE Jean-Marie, Professeur des Universités, INSA Lyon

Examineur

NEWMAN Alantha, Chargée de Recherche, Université Grenoble Alpes

Examinatrice

FAWZI Omar, Directeur de Recherche, Inria et ENS de Lyon

Directeur de thèse



*À ma mère,  
à mon père.*

---

# Abstract

Finding efficient codes is crucial for achieving reliable communication over noisy channels. While error-correcting codes for i.i.d. channels are well understood, the task of approximating the best code for a general channel, i.e. that maximizes the success probability of the encoding and decoding process, is much less developed. This thesis addresses this coding problem in several scenarios.

For point-to-point channels, optimal approximation algorithms for coding and list-decoding are known. We study a generalization of the latter with a variable list size, compensated by an increasing probability of failure. More generally, we study the coverage problem which entails maximizing  $\sum_{a \in [n]} w_a \varphi(|\{i \in S : a \in T_i\}|)$  over subsets  $S \subseteq [m]$  of cardinality  $k$ , for a general nondecreasing concave function  $\varphi$ . We provide an approximation algorithm for that problem of ratio  $\alpha_\varphi := \min_{x \in \mathbb{N}^*} \frac{\mathbb{E}[\varphi(\text{Poi}(x))]}{\varphi(\mathbb{E}[\text{Poi}(x)])}$ , which cannot be improved for sublinear  $\varphi$  if  $\text{P} \neq \text{NP}$ .

For multiple-access channels, we show that the coding problem cannot be approximated within any constant ratio under a complexity hypothesis on random  $k$ -SAT formulas. Generalizing and abstracting quantum entanglement, non-signaling correlations can be used to enhance communication. We show that optimal non-signaling assisted codes for multiple-access channels can be found in polynomial time in the number of copies of the channel. Applied to the binary adder channel, a non-signaling advantage on its capacity region is established. We provide a general single-letter outer bound on the non-signaling capacity region. When non-signaling assistance is not shared between encoders, we show that the capacity region is not changed.

For broadcast channels, when restricted to deterministic channels, we provide a  $(1 - e^{-1})^2$ -approximation algorithm for the unassisted coding problem, and we show that their capacity region is not changed with non-signaling assistance. In the value query model, we show that we cannot achieve a better approximation ratio than  $\Omega\left(\frac{1}{\sqrt{m}}\right)$  for the general broadcast channel coding problem, with  $m$  the output size of the channel.

---

# Résumé

La recherche de codes efficaces est essentielle pour obtenir des communications fiables sur des canaux bruités. Alors que les codes correcteurs d'erreurs pour les canaux i.i.d. sont bien compris, le problème d'approximer le meilleur code pour un canal générique, c'est-à-dire qui maximise la probabilité de succès de la communication sur les canaux bruités, a été beaucoup moins étudié. Cette thèse aborde ce problème de codage dans plusieurs scénarios.

Pour les canaux point-à-point, des algorithmes d'approximation optimaux pour le problème du codage ainsi que le problème du décodage de liste sont connus. Nous étudions une généralisation de ce dernier avec une taille de liste variable, compensée par une probabilité d'échec croissante. Plus généralement, nous étudions le problème de couverture qui consiste à maximiser  $\sum_{a \in [n]} w_a \varphi(|\{i \in S : a \in T_i\}|)$  sur les sous-ensembles  $S \subseteq [m]$  de cardinal  $k$ , pour  $\varphi$  une fonction croissante concave quelconque. Nous proposons un algorithme d'approximation pour ce problème de ratio  $\alpha_\varphi := \min_{x \in \mathbb{N}^*} \frac{\mathbb{E}[\varphi(\text{Poi}(x))]}{\varphi(\mathbb{E}[\text{Poi}(x)])}$ , qui ne peut être amélioré pour  $\varphi$  sous-linéaire si  $P \neq NP$ .

Pour les canaux à accès multiple, nous montrons que le problème du codage ne peut être approximé avec un ratio constant sous une hypothèse de complexité sur des formules  $k$ -SAT aléatoires. En généralisant et en abstrayant l'intrication quantique, les corrélations non-signalantes peuvent être utilisées pour améliorer la communication. Nous montrons que les codes optimaux avec assistance non-signalante pour les canaux à accès multiples peuvent être trouvés en temps polynomial en le nombre de copies du canal. Appliqué au canal additionneur binaire, l'utilisation de corrélations non-signalantes étend sa zone de capacité. Nous fournissons une borne supérieure sur la zone de capacité avec assistance non-signalante. Lorsque l'assistance non-signalante n'est pas partagée entre les encodeurs, nous montrons que la zone de capacité n'est pas modifiée.

Pour les canaux de diffusion, lorsque l'on se limite aux canaux déterministes, nous fournissons une  $(1 - e^{-1})^2$ -approximation pour le problème du codage sans assistance, et nous montrons que leur zone de capacité n'est pas modifiée par l'assistance non-signalante. Dans le modèle d'accès par valeur, nous montrons que nous ne pouvons pas obtenir un meilleur ratio d'approximation que  $\Omega\left(\frac{1}{\sqrt{m}}\right)$  pour le problème global du codage des canaux de diffusion, où  $m$  est la taille de sortie du canal.

---

# Remerciements

Je tiens tout d'abord à remercier mon directeur de thèse Omar Fawzi, qui m'a accompagné durant toute la durée de ma thèse et m'a gratifié de sa présence et de sa disponibilité tout au long de celle-ci.

Je tiens à remercier Mario Berta et Andrei Romashchenko d'avoir accepté de participer à mon jury de thèse en tant que rapporteurs, ainsi qu'à Jean-Marie Gorce et Alantha Newman en tant qu'examineur et examinatrice.

Je tiens également à remercier Siddharth Barman pour les collaborations ainsi que pour les discussions autour des problèmes algorithmiques venant de l'économie.

Merci Stéphan et Pascal pour le temps passé tout au long de cette thèse autour de moments conviviaux et scientifiques. Un grand merci Subhayan pour la bonne humeur à toute épreuve, la compagnie dans l'effort et l'aide généreuse fournie durant toutes ces années. Merci Rémi pour ces débats endiablés qui ont rythmé les semaines et brisé tout risque de monotonie au fil des mois. Merci Peter pour toute l'aide scientifique et l'accueil chaleureux au début de ma thèse. Et merci Julien pour les pauses caféinées et cartonnées nécessaires à la recharge des batteries.

Merci Maïwenn de m'avoir convaincu de me lancer dans cette thèse malgré les hésitations initiales. Merci Lilian d'avoir été présent tout au long de la thèse, autour de restaurants, de musique, de cafés et débats partagés par delà nos laboratoires respectifs.

Un merci très spécial à Léo pour la décennie d'amitié et de soutien réciproque depuis notre rencontre à l'ENS de Lyon. Et un autre merci tout aussi particulier à Nils, pour la musique, pour l'amitié, et pour toutes les expériences partagées depuis à peu près aussi longtemps.

Enfin, merci Claire de m'accompagner dans ce marathon depuis ses débuts et par-delà les épreuves rencontrées en chemin.





---

# Contents

<b>Abstract</b>	<b>iii</b>
<b>Contents</b>	<b>vii</b>
<b>List of Symbols</b>	<b>xi</b>
<b>1 Introduction</b>	<b>1</b>
<b>2 Background</b>	<b>11</b>
2.1 Probability Theory . . . . .	11
2.1.1 Usual Distributions and Properties . . . . .	11
2.1.2 Negatively Associated Random Variables . . . . .	12
2.1.3 Non-Signaling Probability Distributions . . . . .	13
2.2 Information Theory . . . . .	14
2.2.1 Information Quantities . . . . .	14
2.2.2 Typical Sets . . . . .	15
2.2.3 Channels . . . . .	17
2.2.4 Capacity Regions . . . . .	18
2.3 Channel Coding for Point-to-Point Channels . . . . .	19
<b>3 Tight Approximation Guarantees for Concave Coverage Problems</b>	<b>21</b>
3.1 Approximation Algorithm for $\varphi$ -MAXCOVERAGE . . . . .	25
3.1.1 Generalization to Matroid Constraints . . . . .	27
3.2 Hardness of Approximation for $\varphi$ -MAXCOVERAGE . . . . .	28
3.2.1 Partitioning System . . . . .	29
3.2.2 The Reduction . . . . .	30
3.2.3 Further Hardness Under Gap-ETH . . . . .	34
3.3 Applications . . . . .	35
3.3.1 Generalized List-Decoding . . . . .	35
3.3.2 Multiwinner Elections . . . . .	36
3.3.3 Resource Allocation in Multi-Agent Systems . . . . .	37
3.3.4 Vehicle-Target Assignment . . . . .	38
3.3.5 Welfare Maximization for $\varphi$ -Coverage . . . . .	39
3.4 Conclusion . . . . .	40

3.5	Appendix . . . . .	42
3.5.1	General Properties . . . . .	42
3.5.2	Calculations of $\alpha_\varphi$ . . . . .	53
3.5.3	NP-hardness of $\delta, h$ -ARYGAPLABELCOVER . . . . .	55
3.5.4	Proof of Existence of Partitioning Systems . . . . .	56
3.5.5	Proof of Theorem 3.15 . . . . .	57
<b>4</b>	<b>Multiple-Access Channel Coding With Non-Signaling Correlations</b>	<b>59</b>
4.1	Multiple-Access Channels Capacity Regions . . . . .	61
4.1.1	Classical Capacities . . . . .	61
4.1.2	Non-Signaling Assisted Capacities . . . . .	64
4.2	Hardness of Approximation for Multiple-Access Channel Coding . . . . .	70
4.3	Properties of Non-Signaling Assisted Codes . . . . .	73
4.3.1	Symmetrization . . . . .	73
4.3.2	Properties of $S^{\text{NS}}(W, k_1, k_2), \mathcal{C}^{\text{NS}}(W)$ and $\mathcal{C}_0^{\text{NS}}(W)$ . . . . .	75
4.3.3	Linear Program With Reduced Size for Structured Channels . . . . .	80
4.4	Non-Signaling Achievability Bounds . . . . .	85
4.4.1	Zero-Error Non-Signaling Assisted Achievable Rate Pairs . . . . .	85
4.4.2	Non-Signaling Assisted Achievable Rate Pairs With Non-Zero Error . . . . .	87
4.5	Relaxed Non-Signaling Assisted Capacity Region and Outer Bounds . . . . .	90
4.5.1	Outer Bound Part of Theorem 4.25 . . . . .	96
4.5.2	Achievability Part of Theorem 4.25 . . . . .	102
4.6	Independent Non-Signaling Assisted Capacity Region . . . . .	105
4.7	Conclusion . . . . .	108
<b>5</b>	<b>Broadcast Channel Coding With Non-Signaling Correlations</b>	<b>111</b>
5.1	Broadcast Channel Coding . . . . .	113
5.1.1	Broadcast Channels . . . . .	113
5.1.2	The Sum Success Probability $S_{\text{sum}}(W, k_1, k_2)$ . . . . .	113
5.1.3	The Joint Success Probability $S(W, k_1, k_2)$ . . . . .	115
5.2	Non-Signaling Assistance . . . . .	116
5.2.1	Non-Signaling Assistance Between Decoders . . . . .	116
5.2.2	Full Non-Signaling Assistance . . . . .	119
5.3	Approximation Algorithm for Deterministic Broadcast Channel Coding . . . . .	123
5.3.1	Reformulation as a Bipartite Graph Problem . . . . .	124
5.3.2	Approximation Algorithm for DENSESTQUOTIENTGRAPH . . . . .	126
5.3.3	Non-Signaling Assisted Capacity Region for Deterministic Channels . . . . .	128
5.4	Hardness of Approximation for Broadcast Channel Coding . . . . .	133
5.4.1	Social Welfare Reformulation . . . . .	134
5.4.2	Value Query Hardness . . . . .	134
5.4.3	Limitations of the Model . . . . .	140
5.5	Conclusion . . . . .	140
<b>6</b>	<b>Conclusion</b>	<b>141</b>
	<b>Bibliography</b>	<b>145</b>

---

# Table des matières

<b>Résumé</b>	<b>iv</b>
<b>Remerciements</b>	<b>v</b>
<b>Table des matières</b>	<b>x</b>
<b>Liste des symboles et abréviations</b>	<b>xi</b>
<b>1 Introduction</b>	<b>5</b>
<b>2 Préliminaires</b>	<b>11</b>
2.1 Probabilités . . . . .	11
2.2 Théorie de l'information . . . . .	14
2.3 Problème du codage pour les canaux un-à-un . . . . .	19
<b>3 Strictes garanties d'approximation pour des problèmes de couverture concaves</b>	<b>21</b>
3.1 Algorithme d'approximation pour $\varphi$ -MAXCOVERAGE . . . . .	25
3.2 Difficulté d'approximation pour $\varphi$ -MAXCOVERAGE . . . . .	28
3.3 Applications . . . . .	35
3.4 Conclusion . . . . .	40
<b>4 Problème du codage pour les canaux à accès multiple et corrélations non-signalantes</b>	<b>59</b>
4.1 Zones de capacité pour les canaux à accès multiple . . . . .	61
4.2 Difficulté d'approximation pour le problème du codage pour les canaux à accès multiple . . . . .	70

4.3	Propriétés des codes avec assistance non-signalante . . . . .	73
4.4	Bornes sur les taux atteignables avec assistance non-signalante . . . . .	85
4.5	Zone de capacité avec assistance non-signalante relaxée et bornes extérieures	90
4.6	Zone de capacité avec assistance non-signalante indépendante . . . . .	105
4.7	Conclusion . . . . .	108
<b>5</b>	<b>Problème du codage pour les canaux de diffusion et corrélations non-signalantes</b>	<b>111</b>
5.1	Problème du codage pour les canaux de diffusion . . . . .	113
5.2	Assistance non-signalante . . . . .	116
5.3	Algorithme d'approximation pour le problème du codage pour les canaux de diffusion déterministes . . . . .	123
5.4	Difficulté d'approximation pour le problème du codage pour les canaux de diffusion . . . . .	133
5.5	Conclusion . . . . .	140
<b>6</b>	<b>Conclusion</b>	<b>143</b>
	<b>Bibliographie</b>	<b>153</b>

---

# List of Symbols

## GENERAL NOTATIONS

$\mathbb{N}$	the set of nonnegative integers
$\mathbb{R}$	the set of real numbers
$[k]$	the set of integers from 1 to $k$ , i.e. $\{1, \dots, k\}$
$\mathfrak{S}_k$	the set of permutations over $[k]$
$(x, y)$	the set of real numbers $z$ such that $x < z < y$
$k, \ell, n, m, \dots$	nonnegative integers
$x, y, z, \dots$	real numbers
$p, q, \dots$	real numbers between 0 and 1
$\lceil x \rceil / \lfloor x \rfloor$	the ceiling/floor of $x$
$\log(x)$	the binary logarithm of $x$
$e^x / \exp(x)$	the exponential of $x$
$\mathbb{1}_A$	the truth value of the statement $A$
$k!$	the factorial of $k$
$\binom{n}{k}$	the binomial coefficient of parameters $n$ and $k$

## COMPLEXITY

P	the class of problems decidable in polynomial time
NP	the class of problems decidable in nondeterministic polynomial time
$O(f(n))$	a function at most of the order of $f(n)$ when $n$ tends to infinity
$\Omega(f(n))$	a function at least of the order of $f(n)$ when $n$ tends to infinity
$\Theta(f(n))$	a function of the order of $f(n)$ when $n$ tends to infinity
$o(f(n))$	a function dominated by $f(n)$ when $n$ tends to infinity

## GRAPHS

$G = (V, E)$	an undirected graph with vertices in $V$ and edges in $E$
$\deg_G(v)$	the degree of $v$ in $G$ , i.e. the number of edges connected to $v$

## GOUPS

$G$	a group
$g$	an element of the group $G$
$\mathcal{X}, \mathcal{Y}, \mathcal{Z}, \dots$	sets where $G$ acts
$x, y, z, \dots$	elements of $\mathcal{X}, \mathcal{Y}, \mathcal{Z}, \dots$
$g \cdot x$	the action of $g$ on $x$
$\mathcal{O}_G(\mathcal{X})$	the set of orbits of $\mathcal{X}$ under the action of $G$

**PROBABILITY**

$\mathcal{X}, \mathcal{Y}, \mathcal{Z}, \dots$	finite sets
$X, Y, Z, \dots$	random variables over $\mathcal{X}, \mathcal{Y}, \mathcal{Z}, \dots$
$P_X, P_Y, P_Z, \dots$	the probability distributions of $X, Y, Z, \dots$
$\mathbb{P}(E)$	the probability of the event $E$
$\mathbb{E}[X]$	the expectation of $X$
$\sigma_X^2$	the variance of $X$
$\text{Ber}(p)$	the Bernoulli distribution of parameter $p$
$\text{Bin}(n, p)$	the binomial distribution of parameters $n, p$
$\text{Poi}(\lambda)$	the Poisson distribution of parameter $\lambda$

**INFORMATION THEORY**

$W$	a channel, possibly with multiple inputs or multiple outputs
$W \otimes W'$	the tensor product of the channels $W$ and $W'$
$W^{\otimes n}$	the $n$ th tensor product of $W$
$\mathcal{C}[\mathcal{S}](W)$	the capacity region of $W$ for a success probability $\mathcal{S}$
$\mathcal{C}_0[\mathcal{S}](W)$	the zero-error capacity region of $W$ for a success probability $\mathcal{S}$
$x^n, y^n, z^n, \dots$	words in $\mathcal{X}^n, \mathcal{Y}^n, \mathcal{Z}^n, \dots$
$x_i, y_i, z_i, \dots$	the $i$ th letter of $x^n, y^n, z^n, \dots$
$x_{-i}, y_{-i}, z_{-i}, \dots$	the words $x^n, y^n, z^n, \dots$ without their $i$ th letter
$\mathcal{T}_\varepsilon^n(X)$	the set of $\varepsilon$ -typical words of $n$ letters following $X$
$H(X)$	the entropy of $X$
$H(X Y)$	the conditional entropy of $X$ given $Y$
$I(X : Y)$	the mutual information of $X$ and $Y$
$I(X : Y Z)$	the conditional mutual information of $X$ and $Y$ given $Z$
$X \rightarrow Y \rightarrow Z$	a Markov chain

---

# Introduction

With the growing number of connected devices and the explosion in the amount of exchanged data, the need for efficient and reliable communication has never been as critical as in today's world. Noise, coming from physical imperfection, signal interference, or even *lepidopterans* [Hop81], is one of the major hurdles to overcome.

The Theory of Information established by Shannon in his seminal work [Sha48] provides clear and definite answers to the amount of data that can be transmitted through noisy point-to-point channels. The asymptotic rate at which information can be sent through multiple independent copies of a channel is fully characterized by a mathematical quantity called *capacity*. Although one cannot hope to surpass this fundamental limit, developing codes achieving the channel's capacity is not a simple task in practice, as the code construction by Shannon was only probabilistic and the decoding is inefficient as a function of the number of copies of the channel.

Nonetheless, restricting the study to binary symmetric channels, the research in error-correcting codes led to capacity-approaching solutions with efficient encoding and decoding procedures, such as low-density parity-check codes [Gal62], turbo codes [BG96] or more recently polar codes [Ari09]; see [RU08] for a general review on error-correcting codes.

However, in some settings, it cannot be assumed that the channel copies are independent. The field of one-shot information theory [RWW06, Tom12, TBR16] addresses this problem, studying information theoretical quantities defined for a unique copy of an arbitrary channel. Another approach, developed by Barman and Fawzi in [BF18], focuses on the algorithmic aspects of coding for a single copy of a channel. The objective shifts to maximizing the probability of successfully transmitting a message through that channel over all possible encoders and decoders, known as the channel coding problem. As this algorithmic task is NP-hard, they proposed a polynomial-time approximation algorithm achieving a ratio of  $1 - e^{-1}$ , which cannot be increased if  $P \neq NP$  thanks to a connection to the maximum coverage problem [Fei98]. Note that this approach differs from algorithmic information theory [Cha77], where information is defined using Turing machines rather than probability theory.

Following this work, the  $\ell$ -list-decoding task [Eli57, Woz58], where the decoder is only asked to output a list of  $\ell$  possible guesses instead of giving the right input message, was studied from an algorithmic point of view in [BFGG20]. Similarly, they developed a  $\left(1 - \frac{\ell^\ell e^{-\ell}}{\ell!}\right)$ -approximation algorithm running in polynomial time, and proved that this

ratio cannot be increased under the unique games conjecture [Kho02]. More generally, a larger class of combinatorial optimization problems, called maximum  $\ell$ -multi-coverage, falls in the analysis of [BFGG20].

A natural extension of the maximum  $\ell$ -multi-coverage problem entails maximizing the quantity  $\sum_{a \in [n]} w_a \varphi(|\{i \in S : a \in T_i\}|)$  over subsets  $S \subseteq [m]$  of cardinality  $k$ , for a general nondecreasing concave function  $\varphi$ ; the maximum  $\ell$ -multi-coverage problem is retrieved by taking  $\varphi(x) := \min(x, \ell)$ . In terms of channel coding interpretation, this corresponds to what we call  $\varphi$ -list-decoding, where the length restriction on the list of guesses of the decoder in  $\ell$ -list-decoding is replaced by a probability  $\frac{\varphi(\ell)}{\ell}$  of correctly decoding a list of guesses of variable size  $\ell$ . This problem will be the first subject of study of the thesis.

Shaking the physical foundations of the world at the beginning of the twentieth century, the rise of quantum mechanics has revolutionized the comprehension of nature at atomic and subatomic scale. One of its most intriguing characteristics is the notion of *entanglement*. Two entangled particles have the particularity of being correlated, even when spread apart, in a way that cannot be explained by non-quantum physics laws.

Einstein, Podolsky and Rosen [EPR35] first discovered that phenomenon, which implied either that the quantum-mechanical description of physical reality was not complete or that two incompatible physical quantities did not have simultaneously a concrete value. Surprisingly and contrary to the original goal of what has become known as the Einstein–Podolsky–Rosen paradox [EPR35], it is the latter that describes correctly the atomic and subatomic physical reality.

Bell showed in [Bel64] that no hidden-variable theory, where we could associate unknown local variables to each of the entangled particles, would be enough to explain their correlation when spread apart. This *nonlocal* nature of quantum physics is in contradiction with the usual principle of locality of classical physics, which states that any object can be influenced only by its immediate surroundings. The results in [Bel64] were generalized into the so-called CHSH inequality [CHSH69], which if violated, imply that a hidden-variable theory cannot explain the correlations between the particles. These inequalities violations were practically realized by Aspect et al. [ADR82], which finally proved the nonlocal nature of quantum physics.

Another particularity of quantum mechanics is that any measurement of physical properties of a quantum system actually disturbs it. Furthermore, in the case of entangled particles, measuring one of the particles will also affect the other. This *spooky action at a distance*, as stated by Einstein [BBBE71], does not violate special relativity, as one cannot actually transmit information through that process.

However, entanglement can be used to enhance communication. A qubit, the quantum basic unit of information, cannot by itself convey more than one bit of information [Hol73]. However, Bennett and Wiesner showed in [BW92] that if quantum entanglement is shared between the parties, in the form of what is called an EPR pair, then one can actually transmit two bits of information using only one qubit. This is known today as superdense coding. For point-to-point (classical) channels, quantum entanglement shared between the sender and the receiver can increase the optimal success probability of channel coding [CLMW10, PLM<sup>+</sup>11], although it does not increase the channel capacity [BBC<sup>+</sup>93, BSST99]. One can also abstract quantum entanglement into *non-signaling* correlations [Cir80, PR94].



---

In order to understand those, it is useful to look at the game interpretation of the previously mentioned CHSH inequality. We consider a two-player game with Alice and Bob. A referee gives a uniformly random bit  $x$  (resp.  $y$ ) to Alice (resp. Bob), and their common goal is to output respectively bits  $a$  and  $b$  such that  $a \oplus b = x \wedge y$  without communicating, where  $\oplus$  denotes the exclusive disjunction. It is easy to see that no strategy can lead to a better success probability than  $\frac{3}{4}$ , even assuming that hidden variables are shared between the players. However, as shown in [CHSH69], if Alice and Bob share an entangled EPR pair, they can apply well chosen measurements and achieve a success probability of  $\cos^2\left(\frac{\pi}{8}\right) \simeq 0.85$ , which in fact cannot be outperformed [Cir80]. Note that the correlation  $P(ab|xy)$  describing the result of this quantum strategy confirms that no information is transmitted using quantum entanglement. Indeed, one can show that the marginal from a player is independent of the other player's input, that is to say that  $\sum_b P(ab|xy) = \sum_b P(ab|xy')$  and  $\sum_a P(ab|xy) = \sum_a P(ab|x'y)$  for all  $a, b, x, y, x', y'$ . Non-signaling correlations are defined as the set of *all* joint distributions  $P(ab|xy)$  that satisfy the previous equalities. They naturally include quantum strategies, but are in fact stronger, as one can even achieve a success probability of 1 for the CHSH game using a general non-signaling strategy, simply by defining  $P(ab|xy) := \frac{1}{2}$  if  $a \oplus b = x \wedge y$ , and  $P(ab|xy) := 0$  otherwise [PR94].

General non-signaling correlations are not representing physical reality, as they imply stronger nonlocal behaviors than those occurring within quantum mechanics. However, they present a strong theoretical interest. Notably, the description of the set of non-signaling correlations is much simpler than with quantum ones, as they are characterized by simple linear constraints; see [BCP<sup>+</sup>14] for a general review on nonlocality.

The approximation algorithm for the channel coding problem in [BF18] relies in fact on non-signaling assisted codes. As finding the best non-signaling assisted code for a channel is a linear program, it can be solved exactly in polynomial time. They have developed a strategy to transform that non-signaling assisted code into a classical one, losing at most a factor  $1 - e^{-1}$  in the success probability. A more precise statement of this strategy actually implies that the capacity regions with or without non-signaling assistance are the same, retrieving back a result by [Mat12]. It should also be noted that non-signaling assistance does not change the capacity region of the reverse task of channel simulation [CRBT22]. This unexpected link between approximation algorithms for the channel coding problem and non-signaling correlations is the main motivation of the rest of the thesis. Specifically, we will develop these analysis in the main network communication scenarios.

Network information theory, which aims at understanding communication over multiple-sender multiple-receiver channels, was first studied by Shannon in the particular case of two-way channels [Sha61] (known today as interference channels). Later, Cover [Cov72] introduced broadcast channels, with multiple receivers but a single sender. Ahlswede [Ahl73] and independently Liao [Lia73] studied the reverse scenario of multiple-access channels, with multiple senders but a single receiver. These more complex channels allow a better modelization of real-life interconnected communication.

Contrary to the point-to-point setting, nonlocality can increase the capacity of network channels. Quek and Shor showed in [QS17] the existence of two-sender two-receiver interference channels with gaps between their classical, quantum-entanglement assisted and non-signaling assisted capacity regions. Following this result, Leditzky et al. [LALS20, SLSS22] showed that quantum entanglement shared between the two senders of a multiple-access channel can strictly enlarge its capacity region.

We will address the coding problem for both multiple-access channels and broadcast channels. We will study the impact of non-signaling correlations on their capacities, as well as their links to approximation algorithms of the related coding problems.

**Contributions** In Chapter 3 (based on [BFF21]), we consider the following generalization of the maximum  $\ell$ -multi-coverage problem depending on a concave, nondecreasing function  $\varphi$ : given subsets  $T_1, \dots, T_m$  of a universe  $[n]$ , positive weights  $w_a$  on the universe  $[n]$  and an integer  $k$ , the objective is to find a subset  $S \subseteq [m]$  of size  $k$  that maximizes  $C^\varphi(S) := \sum_{a \in [n]} w_a \varphi(|S|_a)$ , where  $|S|_a := |\{i \in S : a \in T_i\}|$ ; the maximum  $\ell$ -multi-coverage problem is retrieved by taking  $\varphi(x) := \min(x, \ell)$ . For any such  $\varphi$ , we provide an efficient algorithm that achieves an approximation ratio equal to the *Poisson concavity ratio* of  $\varphi$ , defined by  $\alpha_\varphi := \min_{x \in \mathbb{N}^*} \frac{\mathbb{E}[\varphi(\text{Poi}(x))]}{\varphi(\mathbb{E}[\text{Poi}(x)])}$ . Complementing this approximation guarantee, we establish a matching NP-hardness result when  $\varphi$  grows in a sublinear way. Applied to channel coding, and more specifically to  $\varphi$ -list-decoding, where the length restriction on the list of guesses of the decoder in  $\ell$ -list-decoding is replaced by a probability  $\frac{\varphi(\ell)}{\ell}$  of correctly decoding a list of guesses of variable size  $\ell$ , we obtain a tight approximation guarantee  $\alpha_\varphi$  for the class of channels  $W$  of the form  $W(y|x) = \frac{1}{t}$  for  $y \in T_x$  with  $|T_x| = t$  and  $W(y|x) = 0$  elsewhere. Our result goes beyond this particular setting and we illustrate it with applications to distributed resource allocation problems, welfare maximization problems and approval-based voting for general rules.

In Chapter 4 (based on [FF22, FF23]), we address the problem of coding for multiple-access channels. We first show that it cannot be approximated in polynomial time within any constant ratio, under a complexity hypothesis on random  $k$ -SAT formulas. Then, we study the influence of non-signaling correlations between parties. We develop a linear program computing the optimal success probability for coding over  $n$  copies of a multiple-access channel  $W$  with size growing polynomially in  $n$ . Solving this linear program allows us to achieve inner bounds for multiple-access channels. Applying this method to the binary adder channel, we show that using non-signaling assistance, the sum-rate  $\frac{\log_2(72)}{4} \simeq 1.5425$  can be reached even with zero error, which beats the maximum sum-rate capacity of 1.5 in the unassisted case. For noisy channels, where the zero-error non-signaling assisted capacity region is trivial, we can use concatenated codes to obtain achievable points in the capacity region. Applied to a noisy version of the binary adder channel, we show that non-signaling assistance still improves the sum-rate capacity. Complementing these achievability results, we give an outer bound on the non-signaling assisted capacity region that has the same expression as the unassisted region except that the channel inputs are not required to be independent. Finally, we show that the capacity region with non-signaling assistance shared only between each sender and the receiver independently is the same as without assistance.

In Chapter 5, we address the problem of coding for broadcast channels. For the class of deterministic broadcast channels, we describe a  $(1 - e^{-1})^2$ -approximation algorithm running in polynomial time, and we show that the capacity region for that class is the same with or without non-signaling assistance. Finally, we show that in the value query model, we cannot achieve a better approximation ratio than  $\Omega\left(\frac{1}{\sqrt{m}}\right)$  in polynomial time for the general broadcast channel coding problem, with  $m$  the size of one of the outputs of the channel.

---

# Introduction

Avec le nombre croissant d'appareils connectés et l'explosion du volume de données échangées, le besoin de communication efficace et fiable n'a jamais été aussi critique que dans le monde d'aujourd'hui. Le bruit, qui provient d'imperfections physiques, d'interférences entre les signaux ou même de *lépidoptères* [Hop81], est l'un des principaux obstacles à surmonter.

La théorie de l'information établie par Shannon dans son ouvrage fondateur [Sha48] apporte des réponses claires et précises à la quantité de données pouvant être transmises par des canaux point à point bruités. Le taux asymptotique auquel les informations peuvent être envoyées par de multiples copies indépendantes d'un canal est entièrement caractérisé par une quantité mathématique appelée *capacité*. Bien que l'on ne puisse espérer dépasser cette limite fondamentale, le développement de codes permettant d'atteindre la capacité du canal n'est pas une tâche aisée en pratique, car la construction du code par Shannon n'était que probabiliste et le décodage est inefficace en fonction du nombre de copies du canal.

Néanmoins, en limitant l'étude aux canaux symétriques binaires, la recherche sur les codes correcteurs d'erreurs a conduit à des solutions approchant la capacité avec des procédures de codage et de décodage efficaces, telles que les codes de contrôle de parité à faible densité [Gal62], les codes turbo [BG96] ou, plus récemment, les codes polaires [Ari09]; voir [RU08] pour une revue générale des codes correcteurs d'erreurs.

Toutefois, dans certains contextes, on ne peut pas supposer que les copies du canal sont indépendantes. Le domaine de la théorie de l'information à un coup [RWW06, Tom12, TBR16] aborde ce problème, en étudiant les quantités de la théorie de l'information définies pour une copie unique d'un canal arbitraire. Une autre approche, développée par Barman et Fawzi dans [BF18], se concentre sur les aspects algorithmiques du codage pour une copie unique d'un canal. L'objectif consiste alors à maximiser la probabilité de transmettre avec succès un message par ce canal pour tous les codeurs et décodeurs possibles, ce que l'on appelle problème du codage de canal. Cette tâche algorithmique étant NP-difficile, ils ont proposé un algorithme d'approximation en temps polynomial atteignant un ratio de  $1 - e^{-1}$ , qui ne peut être augmenté si  $P \neq NP$  grâce à un lien avec le problème de la couverture maximale [Fei98]. Il convient de noter que cette approche diffère de la théorie algorithmique de l'information [Cha77], où l'information est définie à l'aide de machines de Turing plutôt qu'avec la théorie des probabilités.

Suite à ces travaux, le problème du décodage de listes de paramètre  $\ell$  [Eli57, Woz58], où l'on

demande au décodeur de produire une liste de  $\ell$  suppositions possibles au lieu de donner le bon message d'entrée, a été étudié d'un point de vue algorithmique dans [BFGG20]. De même, ils ont développé un algorithme d'approximation de ratio  $1 - \frac{\ell^\ell e^{-\ell}}{\ell!}$  fonctionnant en temps polynomial, et ont prouvé que ce ratio ne peut pas être augmenté sous l'hypothèse de la conjecture des jeux uniques [Kho02]. Plus généralement, une classe plus large de problèmes d'optimisation combinatoire, appelée couverture multiple maximale de paramètre  $\ell$ , relève de l'analyse de [BFGG20].

Une extension naturelle du problème de couverture multiple maximale de paramètre  $\ell$  consiste à maximiser la quantité  $\sum_{a \in [m]} w_a \varphi(|\{i \in S : a \in T_i\}|)$  sur les sous-ensembles  $S \subseteq [m]$  de cardinal  $k$ , pour  $\varphi$  une fonction croissante concave quelconque ; le problème de couverture multiple maximale de paramètre  $\ell$  est retrouvé en prenant  $\varphi(x) := \min(x, \ell)$ . En termes d'interprétation du codage de canal, cela correspond à ce que nous appelons le décodage de liste de paramètre  $\varphi$ , où la restriction de longueur sur la liste de suppositions du décodeur dans le décodage de liste de paramètre  $\ell$  est remplacée par une probabilité  $\frac{\varphi(\ell)}{\ell}$  de décodage correct d'une liste de suppositions de taille variable  $\ell$ . Ce problème sera le premier sujet d'étude de la thèse.

Au début du vingtième siècle, la mécanique quantique a ébranlé les fondements physiques du monde et révolutionné la compréhension de la nature à l'échelle atomique et subatomique. L'une de ses caractéristiques les plus fascinantes est la notion d'*intrication*. Deux particules intriquées ont la particularité d'être corrélées, même lorsqu'elles sont éloignées l'une de l'autre, d'une manière qui ne peut être expliquée par les lois de la physique non quantique.

Einstein, Podolsky et Rosen [EPR35] ont été les premiers à découvrir ce phénomène, qui impliquait soit que la description de la réalité physique par la mécanique quantique n'était pas complète, soit que deux grandeurs physiques incompatibles n'avaient pas simultanément une valeur concrète. De manière surprenante et contrairement à l'objectif initial de ce qui est devenu le paradoxe d'Einstein-Podolsky-Rosen [EPR35], c'est ce dernier qui décrit correctement la réalité physique atomique et subatomique.

Bell a montré dans [Bel64] qu'aucune théorie des variables cachées, où l'on pourrait associer des variables locales inconnues à chacune des particules intriquées, ne suffirait à expliquer leur corrélation lorsqu'elles sont éloignées l'une de l'autre. Cette nature non locale de la physique quantique est en contradiction avec le principe de localité de la physique classique, qui stipule que tout objet ne peut être influencé que par son environnement immédiat. Les résultats de [Bel64] ont été généralisés dans ce que l'on appelle les inégalités CHSH [CHSH69], qui, si elles sont violées, impliquent qu'une théorie des variables cachées ne peut pas expliquer les corrélations entre les particules. Les violations de ces inégalités ont été pratiquement réalisées par Aspect et al. [ADR82], ce qui a finalement prouvé la nature non locale de la physique quantique.

Une autre particularité de la mécanique quantique est que toute mesure des propriétés physiques d'un système quantique le perturbe. En outre, dans le cas de particules intriquées, la mesure de l'une des particules affectera également l'autre. Cette *action étrange à distance*, comme l'a décrite Einstein [BBE71], ne viole pas la relativité restreinte, car il est impossible de transmettre des informations par ce biais.

Cependant, l'intrication peut être utilisée pour améliorer la communication. Un qubit, l'unité quantique de base de l'information, ne peut à lui seul transmettre plus d'un bit d'information [Hol73]. Cependant, Bennett et Wiesner ont montré dans [BW92] que si

---

l'intrication quantique est partagée entre les parties, sous la forme de ce que l'on appelle une paire EPR, il est possible de transmettre deux bits d'information en utilisant un seul qubit. C'est ce que l'on appelle aujourd'hui le codage superdense. Pour les canaux point à point (classiques), l'intrication quantique partagée entre l'émetteur et le récepteur peut augmenter la probabilité de succès optimale du codage de canal [CLMW10, PLM<sup>+</sup>11], bien qu'elle n'augmente pas la capacité du canal [BBC<sup>+</sup>93, BSST99].

On peut également abstraire l'intrication quantique en corrélations *non-signalantes* [Cir80, PR94]. Afin de comprendre ces corrélations, il est utile d'examiner l'interprétation de l'inégalité CHSH mentionnée précédemment sous forme de jeu. Nous considérons un jeu à deux joueurs avec Alice et Bob. Un arbitre donne un bit uniformément aléatoire  $x$  (resp.  $y$ ) à Alice (resp. Bob), et leur but commun est de choisir respectivement les bits  $a$  et  $b$  tels que  $a \oplus b = x \wedge y$  sans communiquer, où  $\oplus$  dénote la disjonction exclusive. Il est facile de voir qu'aucune stratégie ne peut conduire à une meilleure probabilité de succès que  $\frac{3}{4}$ , même en supposant que des variables cachées sont partagées entre les joueurs. Cependant, comme le montre [CHSH69], si Alice et Bob partagent une paire EPR intriquée, ils peuvent appliquer des mesures bien choisies et atteindre une probabilité de succès de  $\cos^2(\frac{\pi}{8}) \simeq 0.85$ , ce qui en fait ne peut pas être surpassé [Cir80]. Notons que la corrélation  $P(ab|xy)$  décrivant le résultat de cette stratégie quantique confirme qu'aucune information n'est transmise à l'aide de l'intrication quantique. En effet, on peut montrer que la marginale d'un joueur est indépendante de l'entrée de l'autre joueur, c'est-à-dire que  $\sum_b P(ab|xy) = \sum_b P(ab|xy')$  et  $\sum_a P(ab|xy) = \sum_a P(ab|x'y)$  pour tous  $a, b, x, y, x', y'$ . Les corrélations non-signalantes sont définies comme l'ensemble des distributions conjointes  $P(ab|xy)$  qui satisfont les égalités précédentes. Elles incluent naturellement les stratégies quantiques, mais sont en fait plus fortes, car on peut même obtenir une probabilité de succès de 1 pour le jeu CHSH en utilisant une stratégie générale non-signalante, simplement en définissant  $P(ab|xy) := \frac{1}{2}$  si  $a \oplus b = x \wedge y$ , et  $P(ab|xy) := 0$  sinon [PR94].

Les corrélations non-signalantes générales ne représentent pas la réalité physique, car elles impliquent des comportements non locaux plus forts que ceux qui se produisent dans le cadre de la mécanique quantique. Cependant, elles présentent un grand intérêt théorique. Notamment, la description de l'ensemble des corrélations non-signalantes est beaucoup plus simple que celle des corrélations quantiques, car elles sont caractérisées par de simples contraintes linéaires; voir [BCP<sup>+</sup>14] pour une revue générale sur la non-localité.

L'algorithme d'approximation pour le problème du codage de canal dans [BF18] s'appuie en fait sur des codes avec assistance non-signalante. Comme la recherche du meilleur code avec assistance non-signalante pour un canal est un programme linéaire, il peut être résolu exactement en temps polynomial. Ils ont mis au point une stratégie pour transformer ce code avec assistance non-signalante en un code classique, en perdant au maximum un facteur  $1 - e^{-1}$  dans la probabilité de succès. Un énoncé plus précis de cette stratégie implique en fait que les zones de capacité avec ou sans assistance non-signalante sont les mêmes, retrouvant un résultat de [Mat12]. Il convient également de noter que l'assistance non-signalante ne modifie pas la zone de capacité de la tâche inverse de simulation des canaux [CRBT22]. Ce lien inattendu entre les algorithmes d'approximation pour le problème du codage de canal et les corrélations non-signalantes, est la motivation principale du reste de la thèse. En particulier, nous développerons ces analyses dans les principaux scénarios de communication en réseau.

La théorie de l'information des réseaux, qui vise à comprendre la communication sur des

canaux à émetteurs multiples et à récepteurs multiples, a été étudiée pour la première fois par Shannon dans le cas particulier des canaux deux-à-deux [Sha61] (connus aujourd'hui sous le nom de canaux d'interférence). Plus tard, Cover [Cov72] a introduit les canaux de diffusion, avec plusieurs récepteurs mais un seul émetteur. Ahlswede [Ahl73] et indépendamment Liao [Lia73] ont étudié le scénario inverse des canaux à accès multiple, avec plusieurs émetteurs mais un seul récepteur. Ces canaux plus complexes permettent une meilleure modélisation des communications interconnectées réelles.

Contrairement à la situation point-à-point, la non-localité peut augmenter la capacité des canaux en réseau. Quek et Shor ont montré dans [QS17] l'existence de canaux d'interférence à deux émetteurs et deux récepteurs avec des écarts entre leurs zones de capacité classique, avec assistance d'intrication quantique et avec assistance non-signalante. À la suite de ce résultat, Leditzky et al. [LALS20, SLSS22] ont montré que l'intrication quantique partagée entre les deux émetteurs d'un canal à accès multiple peut strictement agrandir sa zone de capacité.

Nous aborderons le problème du codage pour les canaux à accès multiple et les canaux de diffusion. Nous étudierons l'impact des corrélations non-signalantes sur leurs capacités, ainsi que leurs liens avec les algorithmes d'approximation des problèmes de codage associés.

**Résumé des chapitres** Dans le Chapitre 3 (basé sur [BFF21]), nous considérons la généralisation suivante du problème de couverture multiple maximale de paramètre  $\ell$  dépendant d'une fonction croissante concave  $\varphi$  : étant donné des sous-ensembles  $T_1, \dots, T_m$  d'un univers  $[n]$ , des poids strictement positifs  $w_a$  sur l'univers  $[n]$  et d'un entier  $k$ , l'objectif est de trouver un sous-ensemble  $S \subseteq [n]$  de taille  $k$  qui maximise  $C^\varphi(S) := \sum_{a \in [n]} w_a \varphi(|S|_a)$ , où  $|S|_a := |\{i \in S : a \in T_i\}|$ ; le problème de couverture multiple maximale de paramètre  $\ell$  est retrouvé en prenant  $\varphi(x) := \min(x, \ell)$ . Pour tout  $\varphi$  de ce type, nous fournissons un algorithme efficace qui permet d'obtenir un rapport d'approximation égal au *rapport de concavité de Poisson* de  $\varphi$ , défini par  $\alpha_\varphi := \min_{x \in \mathbb{N}^*} \frac{\mathbb{E}[\varphi(\text{Poi}(x))]}{\varphi(\mathbb{E}[\text{Poi}(x)])}$ . En complément de cette garantie d'approximation, nous établissons un résultat de NP-difficulté lorsque  $\varphi$  croît de manière sous-linéaire. Appliqué au codage de canal, et plus spécifiquement au décodage de liste de paramètre  $\varphi$ , où la restriction de longueur sur la liste de suppositions du décodeur dans le décodage de liste de paramètre  $\ell$  est remplacée par une probabilité  $\frac{\varphi(\ell)}{\ell}$  de décoder correctement une liste de suppositions de taille variable  $\ell$ , nous obtenons une stricte garantie d'approximation  $\alpha_\varphi$  pour la classe de canaux  $W$  de la forme  $W(y|x) = \frac{1}{t}$  pour  $y \in T_x$  avec  $|T_x| = t$  et  $W(y|x) = 0$  ailleurs. Notre résultat dépasse ce cadre particulier et nous l'illustrons par des applications aux problèmes d'allocation de ressources distribuées, aux problèmes de maximisation de la prospérité et au vote basé sur l'approbation pour des règles générales.

Dans le Chapitre 4 (basé sur [FF22, FF23]), nous abordons le problème du codage pour les canaux à accès multiple. Nous montrons tout d'abord qu'il ne peut pas être approximé en temps polynomial avec un ratio constant, sous une hypothèse de complexité sur des formules  $k$ -SAT aléatoires. Ensuite, nous étudions l'influence des corrélations non signalantes entre les parties. Nous développons un programme linéaire calculant la probabilité de succès optimale pour le codage sur  $n$  copies d'un canal d'accès multiple  $W$  dont la taille croît polynomialement en  $n$ . La résolution de ce programme linéaire nous permet d'obtenir des bornes inférieures pour les canaux à accès multiple. En appliquant cette méthode au canal additionneur binaire, nous montrons qu'en utilisant une assistance non-signalante, la

---

somme des taux  $\frac{\log_2(72)}{4} \simeq 1.5425$  peut être atteinte même avec une erreur nulle, ce qui dépasse la capacité maximale de la somme des taux de 1.5 dans le cas sans assistance. Pour les canaux bruités, où la région de capacité avec assistance non-signalante et sans erreur est triviale, nous pouvons utiliser des codes concaténés pour obtenir des points réalisables dans la zone de capacité. Appliqués à une version bruitée du canal additionneur binaire, nous montrons que l'assistance non-signalante améliore encore la capacité. En complément de ces résultats de faisabilité, nous donnons une borne supérieure à la zone de capacité avec assistance non-signalante qui a la même expression que la région sans assistance, sauf que les entrées du canal ne sont pas obligées d'être indépendantes. Enfin, nous montrons que la zone de capacité avec assistance non-signalante partagée uniquement entre chaque émetteur et le récepteur indépendamment est la même que sans assistance.

Dans le Chapitre 5, nous abordons le problème du codage pour les canaux de diffusion. Pour la classe des canaux de diffusion déterministes, nous décrivons un algorithme d'approximation de ratio  $(1 - e^{-1})^2$  fonctionnant en temps polynomial, et nous montrons que la zone de capacité pour cette classe est la même avec ou sans assistance non-signalante. Enfin, nous montrons que dans le modèle d'accès par valeur, nous ne pouvons pas obtenir un meilleur ratio d'approximation que  $\Omega\left(\frac{1}{\sqrt{m}}\right)$  en temps polynomial pour le problème général du codage des canaux de diffusion, avec  $m$  la taille de l'une des sorties du canal.





# Background

In this chapter, we recall briefly basic definitions and properties, as well as more unusual results, used throughout the thesis. Rather than an introduction to each of those topics, one should see this chapter as a toolbox and use it when needed in the other chapters.

## 2.1 Probability Theory

### 2.1.1 Usual Distributions and Properties

**Definition 2.1** (Usual Distributions). We will consider the following probability distributions:

1. The Bernoulli distribution  $\text{Ber}(p)$  is defined on  $\{0, 1\}$  with the mass function:

$$(1 - p, p) .$$

2. The binomial distribution  $\text{Bin}(n, p)$  is defined on  $\{0, \dots, n\}$  with the mass function:

$$\left( \binom{n}{k} p^k (1 - p)^{n-k} \right)_{k \in \{0, \dots, n\}} .$$

3. The Poisson distribution  $\text{Poi}(\lambda)$  is defined on  $\mathbb{N}$  with the mass function:

$$\left( \frac{\lambda^k e^{-\lambda}}{k!} \right)_{k \in \mathbb{N}} .$$

**Proposition 2.1** (Jensen's Inequality [Jen06]). For  $X$  random variable and  $\varphi$  concave, we have:

$$\mathbb{E} [\varphi(X)] \leq \varphi (\mathbb{E}[X]) .$$

**Proposition 2.2.** For  $\varphi$  concave, and  $p \in [0, 1]^m$ , we have:

$$\mathbb{E} \left[ \varphi \left( \sum_{i=1}^m \text{Ber}(p_i) \right) \right] \geq \mathbb{E} \left[ \varphi \left( \text{Poi} \left( \sum_{i=1}^m p_i \right) \right) \right] .$$

*Proof.* The notion of *convex order* discussed in [SS07] allows us to prove this result. We say that  $X \leq_{\text{cx}} Y \iff \mathbb{E}[f(X)] \leq \mathbb{E}[f(Y)]$  for any convex  $f$ . Thanks to Lemma 2.3 of [BFGG20], we have that for  $p \in [0, 1]$ :

$$\text{Ber}(p) \leq_{\text{cx}} \text{Poi}(p) .$$

Since this order is preserved through convolution (Theorem 3.A.12 of [SS07]), and the fact that  $\sum_{i=1}^m \text{Poi}(p_i) \sim \text{Poi}(\sum_{i=1}^m p_i)$ , we have:

$$\sum_{i=1}^m \text{Ber}(p_i) \leq_{\text{cx}} \text{Poi}\left(\sum_{i=1}^m p_i\right) .$$

Applying this result to  $-\varphi$ , which is convex, concludes the proof.  $\square$

### 2.1.2 Negatively Associated Random Variables

We present a weaker notion of independence for random variables which is called negative association as introduced in [JDP83], for which the Chernoff-Hoeffding bounds still hold.

**Definition 2.2.** Random variables  $X_1, \dots, X_n$  are said to be negatively associated if for every pair of disjoint subsets  $I, J$  of  $[n]$  and (coordinate-wise) increasing functions  $f, g$ , we have:

$$\mathbb{E}[f(\{X_i : i \in I\})] \cdot \mathbb{E}[g(\{X_i : i \in J\})] \leq \mathbb{E}[f(\{X_i : i \in I\})] \cdot \mathbb{E}[g(\{X_i : i \in J\})] .$$

**Proposition 2.3** (Property P<sub>1</sub> of [JDP83]). *A pair of random variable  $X, Y$  is negatively associated if and only if:*

$$\forall x \in \mathcal{X}, \forall y \in \mathcal{Y}, P_{XY}(x, y) \leq P_X(x)P_Y(y) .$$

**Proposition 2.4** (Property P<sub>4</sub> of [JDP83]). *A subset of two or more negatively associated random variables is negatively associated.*

**Proposition 2.5** (Property P<sub>5</sub> of [JDP83]). *A set of independent random variables is negatively associated.*

**Proposition 2.6** (Property P<sub>6</sub> of [JDP83]). *Increasing functions defined on disjoint subsets of a set of negatively associated random variables are negatively associated.*

**Proposition 2.7** (Property P<sub>7</sub> of [JDP83]). *The union of independent sets of negatively associated random variables is negatively associated.*

**Definition 2.3** (Permutation Distribution). Let  $x = (x_1, \dots, x_k) \in \mathbb{R}^k$ . A permutation distribution is the joint distribution of the vector  $X = (X_1, \dots, X_k)$  which takes as values all  $k!$  permutations of  $x$  with equal probabilities, each being  $\frac{1}{k!}$ .

**Proposition 2.8** (Theorem 2.11 of [JDP83]). *A permutation distribution is negatively associated.*

**Proposition 2.9** (Chernoff-Hoeffding bound - version 1). *Let  $X_1, \dots, X_n$  be negatively associated random variables such that  $0 \leq X_i \leq B$  and  $\mathbb{E}[X_i] = \mu$ . Then for  $\eta \in (0, 1)$ :*

$$\mathbb{P}\left(\left|\frac{1}{n} \sum_{i=1}^n X_i - \mu\right| > \eta\right) \leq 2e^{-2\left(\frac{\eta}{B}\right)^2 n} .$$

*Proof.* This usual version of the Chernoff-Hoeffding bound for independent variables (Theorem 2 of [Hoe63]) can be extended to negatively associated random variables directly as pointed out by [DR98].  $\square$

**Proposition 2.10** (Chernoff-Hoeffding bound - version 2). *Let  $X_1, \dots, X_n$  be negatively associated Bernoulli random variables of parameter  $p$ . Then for  $0 < \varepsilon \leq \frac{1}{2}$ :*

$$\mathbb{P} \left( \frac{1}{n} \sum_{i=1}^n X_i > (1 + \varepsilon)p \right) \leq e^{-\frac{pn\varepsilon^2}{4}} .$$

*Proof.* Usual proofs of the Chernoff-Hoeffding bound work in the same way with negatively associated variables as pointed out by [DR98]. So, one obtains as in the original proof (Theorem 1 of [Hoe63]) that:

$$\mathbb{P} \left( \frac{1}{n} \sum_{i=1}^n X_i > (1 + \varepsilon)p \right) \leq e^{-D((1+\varepsilon)p||p)n} ,$$

with  $D(x||y) := x \ln \left( \frac{x}{y} \right) + (1-x) \ln \left( \frac{1-x}{1-y} \right)$  the Kullback–Leibler divergence between Bernoulli distributed random variables with parameters  $x$  and  $y$ . As  $D((1+\varepsilon)p||p) \geq \frac{\varepsilon^2 p}{4}$  for  $0 < \varepsilon < \frac{1}{2}$ , we recover the expected bound.  $\square$

### 2.1.3 Non-Signaling Probability Distributions

**Definition 2.4.** We say that a conditional probability distribution  $P(a^n|x^n)$  defined on  $\times_{i=1}^n \mathcal{A}_i \times \times_{i=1}^n \mathcal{X}_i$  is *non-signaling* if for all  $a^n, x^n, \hat{x}^n$ , we have

$$\forall i \in [n], \sum_{\hat{a}_i} P(a_1 \dots \hat{a}_i \dots a_n | x_1 \dots x_i \dots x_n) = \sum_{\hat{a}_i} P(a_1 \dots \hat{a}_i \dots a_n | x_1 \dots \hat{x}_i \dots x_n) .$$

**Definition 2.5.** Let  $P(a^n|x^n)$  a conditional probability distribution defined on  $\times_{i=1}^n \mathcal{A}_i \times \times_{i=1}^n \mathcal{X}_i$  and  $P'(a'^n|x'^n)$  defined on  $\times_{i=1}^n \mathcal{A}'_i \times \times_{i=1}^n \mathcal{X}'_i$ . We define  $P \otimes P'$  the tensor product conditional probability distribution defined on  $\times_{i=1}^n (\mathcal{A}_i \times \mathcal{A}'_i) \times \times_{i=1}^n (\mathcal{X}_i \times \mathcal{X}'_i)$  by  $(P \otimes P')(a_1 a'_1 \dots a_n a'_n | x_1 x'_1 \dots x_n x'_n) := P(a^n|x^n) \cdot P'(a'^n|x'^n)$ .

**Proposition 2.11.** *If both  $P$  and  $P'$  are non-signaling, then  $P \otimes P'$  is non-signaling.*

*Proof.* Let  $a^n \in \times_{j=1}^n \mathcal{A}_j$ ,  $a'^n \in \times_{j=1}^n \mathcal{A}'_j$ ,  $x^n \in \times_{j=1}^n \mathcal{X}_j$ ,  $x'^n \in \times_{j=1}^n \mathcal{X}'_j$  and  $\hat{x}_i \in \mathcal{X}_i$ ,

$\hat{x}'_i \in \mathcal{X}'_i$ . Using the fact that  $P, P'$  are non-signaling, we have:

$$\begin{aligned}
 & \sum_{\hat{a}_i \hat{a}'_i} P(a_1 a'_1 \dots \hat{a}_i \hat{a}'_i \dots a_n a'_n | x_1 x'_1 \dots x_i x'_i \dots x_n x'_n) \\
 &= \sum_{\hat{a}_i \hat{a}'_i} P(a_1 \dots \hat{a}_i \dots a_n | x_1 \dots x_i \dots x_n) \cdot P'(a'_1 \dots \hat{a}'_i \dots a'_n | x'_1 \dots x'_i \dots x'_n) \\
 &= \left( \sum_{\hat{a}_i} P(a_1 \dots \hat{a}_i \dots a_n | x_1 \dots x_i \dots x_n) \right) \cdot \left( \sum_{\hat{a}'_i} P'(a'_1 \dots \hat{a}'_i \dots a'_n | x'_1 \dots x'_i \dots x'_n) \right) \\
 &= \left( \sum_{\hat{a}_i} P(a_1 \dots \hat{a}_i \dots a_n | x_1 \dots \hat{x}_i \dots x_n) \right) \cdot \left( \sum_{\hat{a}'_i} P'(a'_1 \dots \hat{a}'_i \dots a'_n | x'_1 \dots \hat{x}'_i \dots x'_n) \right) \\
 &= \sum_{\hat{a}_i \hat{a}'_i} (P \otimes P')(a_1 a'_1 \dots \hat{a}_i \hat{a}'_i \dots a_n a'_n | x_1 x'_1 \dots \hat{x}_i \hat{x}'_i \dots x_n x'_n),
 \end{aligned} \tag{2.1}$$

so  $P \otimes P'$  is non-signaling.  $\square$

## 2.2 Information Theory

### 2.2.1 Information Quantities

Here,  $X, Y, Z$  will denote random variables over finite sets  $\mathcal{X}, \mathcal{Y}, \mathcal{Z}$  and we will denote their distributions by  $P_X(x) = \mathbb{P}(X = x)$ ,  $P_{X,Y}(x, y) = \mathbb{P}(X = x, Y = y)$ ,  $P_{X|Y}(x|y) = \mathbb{P}(X = x | Y = y), \dots$

**Definition 2.6** ((Shannon) Entropy  $H(X)$ ). The (Shannon) entropy  $H(X)$  of  $X$  is defined by:

$$H(X) := \mathbb{E}_X[-\log(P_X(X))] = - \sum_{x \in \mathcal{X}} P_X(x) \log(P_X(x)).$$

The entropy of two random variables  $X, Y$  is defined as  $H(X, Y) := H((X, Y))$ .

**Definition 2.7** (Conditional Entropy  $H(X|Y)$ ). The conditional entropy  $H(X|Y)$  of  $X$  given  $Y$  is defined by:

$$\begin{aligned}
 H(X|Y) &:= \sum_{y \in \mathcal{Y}} P_Y(y) H(X|Y = y) \\
 &= \sum_{y \in \mathcal{Y}} P_Y(y) \left( - \sum_{x \in \mathcal{X}} P_{X|Y}(x|y) \log(P_{X|Y}(x|y)) \right) \\
 &= - \sum_{x \in \mathcal{X}, y \in \mathcal{Y}} P_{X,Y}(x, y) \log(P_{X|Y}(x|y)).
 \end{aligned} \tag{2.2}$$

**Definition 2.8** (Mutual Information  $I(X : Y)$ ). The mutual information  $I(X : Y)$  of  $X$  and  $Y$  is defined by:

$$I(X : Y) := \sum_{x \in \mathcal{X}, y \in \mathcal{Y}} P_{X,Y}(x, y) \log \left( \frac{P_{X,Y}(x, y)}{P_X(x) P_Y(y)} \right).$$

**Proposition 2.12.** *Equivalently, we have:*

$$I(X : Y) = H(X) - H(X|Y) = H(Y) - H(Y|X) = H(X) + H(Y) - H(X, Y) .$$

**Definition 2.9** (Conditional Mutual Information  $I(X : Y|Z)$ ). The mutual information  $I(X : Y|Z)$  of  $X$  and  $Y$  given  $Z$  is defined by:

$$\begin{aligned} I(X : Y|Z) &:= \sum_{z \in \mathcal{Z}} P_Z(z) I(X : Y|Z = z) \\ &= \sum_{x \in \mathcal{X}, y \in \mathcal{Y}, z \in \mathcal{Z}} P_{X,Y,Z}(x, y, z) \log \left( \frac{P_{X,Y|Z}(x, y|z)}{P_{X|Z}(x|z) P_{Y|Z}(y|z)} \right) . \end{aligned} \quad (2.3)$$

**Definition 2.10** (Markov chain  $X \rightarrow Y \rightarrow Z$ ). We say that  $X \rightarrow Y \rightarrow Z$  forms a Markov chain if  $Z$  is conditionally independent of  $X$  given  $Y$ , that is to say:

$$\forall x \in \mathcal{X}, \forall y \in \mathcal{Y}, \forall z \in \mathcal{Z}, P_{Z|X,Y}(z|x, y) = P_{Z|Y}(z|y) .$$

### 2.2.2 Typical Sets

We consider typical sets as defined in Chapter 2.5 of [GK11]:

**Definition 2.11** (Typical set and conditional typical set). We have the following definitions:

1.  $\mathcal{T}_\varepsilon^n(X) := \{x^n : |\pi(x|x^n) - P_X(x)| \leq \varepsilon P_X(x) \text{ for all } x \in \mathcal{X}\}$ , with the empirical distribution  $\pi$  defined by  $\pi(x|x^n) := \frac{|\{i: x_i = x\}|}{n}$ . This definition generalizes for any  $t$ -tuple of variables.
2.  $\forall y^n \in \mathcal{T}_\varepsilon^n(Y), \mathcal{T}_\varepsilon^n(X|y^n) := \{x^n : (x^n, y^n) \in \mathcal{T}_\varepsilon^n(X, Y)\}$ .

A crucial property of such typical sets is the typical average lemma:

**Lemma 2.13** (Typical Average Lemma [GK11]). *Let  $x^n \in \mathcal{T}_\varepsilon^n(X)$ . Then for any nonnegative function  $g$  on  $\mathcal{X}$ :*

$$(1 - \varepsilon) \mathbb{E}[g(X)] \leq \frac{1}{n} \sum_{i=1}^n g(x_i) \leq (1 + \varepsilon) \mathbb{E}[g(X)] .$$

In particular, with this tool, we can derive the following properties:

**Proposition 2.14** (Properties of typical sets [GK11]). *We have, among others, the following statements about typical sets:*

1.  $\forall x^n \in \mathcal{T}_\varepsilon^n(X), 2^{-n(1+\varepsilon)H(X)} \leq P_{X^n}(x^n) \leq 2^{-n(1-\varepsilon)H(X)}$ .
2.  $\lim_{n \rightarrow +\infty} \mathbb{P}(X^n \in \mathcal{T}_\varepsilon^n(X)) = 1$ .
3.  $|\mathcal{T}_\varepsilon^n(X)| \leq 2^{n(1+\varepsilon)H(X)}$ .
4. For  $n$  sufficiently large,  $|\mathcal{T}_\varepsilon^n(X)| \geq (1 - \varepsilon) 2^{n(1-\varepsilon)H(X)}$ .
5. If  $(x^n, y^n) \in \mathcal{T}_\varepsilon^n(X, Y)$  then  $x^n \in \mathcal{T}_\varepsilon^n(X)$  and  $y^n \in \mathcal{T}_\varepsilon^n(Y)$ .

## 2. BACKGROUND

6.  $\forall y^n \in \mathcal{T}_\varepsilon^n(Y), \mathcal{T}_\varepsilon^n(X|y^n) \subseteq \mathcal{T}_\varepsilon^n(X)$ .
7.  $\forall (x^n, y^n) \in \mathcal{T}_\varepsilon^n(X, Y), 2^{-n(1+\varepsilon)H(X|Y)} \leq P_{X^n Y^n}(x^n|y^n) \leq 2^{-n(1-\varepsilon)H(X|Y)}$ .
8.  $\forall y^n \in \mathcal{T}_\varepsilon^n(Y), |\mathcal{T}_\varepsilon^n(X|y^n)| \leq 2^{n(1+\varepsilon)H(X|Y)}$ .
9. For  $\varepsilon' < \varepsilon$  and  $n$  sufficiently large, we have that  $\forall y^n \in \mathcal{T}_{\varepsilon'}^n(Y), |\mathcal{T}_\varepsilon^n(X|y^n)| \geq (1 - \varepsilon)2^{n(1-\varepsilon)H(X|Y)}$ .

*Proof.* We reproduce the proof of the last statement here to emphasize on the fact that there is an  $n_0$  such that for all  $n \geq n_0$  and for all  $y^n \in \mathcal{T}_{\varepsilon'}^n(Y)$ , the property holds.

For any  $\varepsilon > \varepsilon' > 0$ , let us show that there exists  $n$  such that we have:

$$\forall y^n \in \mathcal{T}_{\varepsilon'}^n(Y), \mathbb{P}((X^n, y^n) \in \mathcal{T}_\varepsilon^n(X, Y)) \geq 1 - \varepsilon,$$

where  $X^n$  are drawn from the distribution  $P_{X^n|Y^n=y^n}$ . This will imply the statement. Indeed, we have that:

$$\begin{aligned} \mathbb{P}((X^n, y^n) \in \mathcal{T}_\varepsilon^n(X, Y)) &= \sum_{x^n \in \mathcal{T}_\varepsilon^n(X|y^n)} P_{X^n|Y^n}(x^n|y^n) \\ &\leq |\mathcal{T}_\varepsilon^n(X|y^n)| 2^{-n(1-\varepsilon)H(X|Y)}, \end{aligned} \quad (2.4)$$

since  $P_{X^n|Y^n}(x^n|y^n) \leq 2^{-n(1-\varepsilon)H(X|Y)}$  as  $(x^n, y^n) \in \mathcal{T}_\varepsilon^n(X, Y)$ . Thus, we have that  $|\mathcal{T}_\varepsilon^n(X|y^n)| \geq (1 - \varepsilon)2^{n(1-\varepsilon)H(X|Y)}$ . In order to prove our result, we take the proof in Appendix 2A of [GK11]. We take  $y^n \in \mathcal{T}_{\varepsilon'}^n(\mathcal{Y})$  and  $X^n \sim P_{X^n|Y^n}(x^n|y^n) = \prod_{i=1}^n P_{X|Y}(x_i|y_i)$ . Applied to our choice of variables, we have that  $\mathbb{P}((X^n, y^n) \notin \mathcal{T}_\varepsilon^n(X, Y))$  is equal to:

$$\begin{aligned} &\mathbb{P}(\exists(x, y) : |\pi(x, y|X^n, y^n) - P_{XY}(x, y)| > \varepsilon P_{XY}(x, y)) \\ &\leq \sum_{x, y} \mathbb{P}(|\pi(x, y|X^n, y^n) - P_{XY}(x, y)| > \varepsilon P_{XY}(x, y)) \\ &= \sum_{x, y} \mathbb{P}\left(\left|\frac{\pi(x, y|X^n, y^n)}{P_{XY}(x, y)} - 1\right| > \varepsilon\right) \\ &= \sum_{x, y} \mathbb{P}\left(\left|\frac{\pi(x, y|X^n, y^n)}{P_{X|Y}(x|y)\pi(y|y^n)} \frac{\pi(y|y^n)}{P_Y(y)} - 1\right| > \varepsilon\right) \\ &\leq \sum_{x, y} \mathbb{P}\left(\frac{\pi(x, y|X^n, y^n)}{\pi(y|y^n)} > \frac{1 + \varepsilon}{1 + \varepsilon'} P_{X|Y}(x|y)\right) \\ &\quad + \sum_{x, y} \mathbb{P}\left(\frac{\pi(x, y|X^n, y^n)}{\pi(y|y^n)} < \frac{1 - \varepsilon}{1 - \varepsilon'} P_{X|Y}(x|y)\right), \end{aligned} \quad (2.5)$$

since  $y^n \in \mathcal{T}_{\varepsilon'}^n(\mathcal{Y})$  and thus  $1 - \varepsilon' \leq \frac{\pi(y|y^n)}{P_Y(y)} \leq 1 + \varepsilon'$ . However, since  $\varepsilon' < \varepsilon$ , we have  $\frac{1+\varepsilon}{1+\varepsilon'} > 1$  and  $\frac{1-\varepsilon}{1-\varepsilon'} < 1$ . We will show that for all  $x, y$  with  $P_Y(y) > 0$ , we have  $\frac{\pi(x, y|X^n, y^n)}{\pi(y|y^n)} \xrightarrow[n \rightarrow +\infty]{} P_{X|Y}(x|y)$  in probability, with a convergence rate independent of  $y^n \in \mathcal{T}_{\varepsilon'}^n(Y)$ , which will be enough to conclude the proof.

Let us fix some  $x, y$  with  $P_Y(y) > 0$ . Since  $y^n \in \mathcal{T}_{\varepsilon'}^n(Y)$ , we have in particular that  $(1 - \varepsilon')P_Y(y) \leq \pi(y|y^n) \leq (1 + \varepsilon')P_Y(y)$ . Thus  $N := |\{i : y_i = y\}| = n\pi(y|y^n) \geq$

$(1 - \varepsilon')P_Y(y)n$ . Then we have:

$$\frac{\pi(x, y|X^n, y^n)}{\pi(y|y^n)} = \frac{1}{N} \sum_{i \in S} Z_i \text{ with } Z_i := \mathbb{1}_{X_i=x} \text{ and } S := \{i : y_i = y\}.$$

Thus, all  $Z_i$  with  $i \in S$  are independent and follow the same law:

$$Z_i := \begin{cases} 1 & \text{with probability } P_{X|Y}(x|y), \\ 0 & \text{otherwise.} \end{cases}$$

Furthermore, we have  $\mathbb{E}[Z_i] = P_{X|Y}(x|y)$ , and all  $Z_i$  have the same variance  $\sigma_{x|y}^2 < +\infty$  (depending only on  $X, Y, x, y$ ). Thus we can apply Chebyshev inequality:

$$\mathbb{P}\left(\left|\frac{1}{N} \sum_{i \in S} Z_i - P_{X|Y}(x|y)\right| \geq \eta\right) \leq \frac{\sigma_{x|y}^2}{N\eta^2}.$$

However, since  $N \geq (1 - \varepsilon')P_Y(y)n$ , we get:

$$\mathbb{P}\left(\left|\frac{\pi(x, y|X^n, y^n)}{\pi(y|y^n)} - P_{X|Y}(x|y)\right| \geq \eta\right) \leq \frac{\sigma_{x|y}^2}{\eta^2(1 - \varepsilon')P_Y(y)n} \xrightarrow{n \rightarrow +\infty} 0.$$

Thus, we have  $\frac{\pi(x, y|X^n, y^n)}{\pi(y|y^n)} \xrightarrow{n \rightarrow +\infty} P_{X|Y}(x|y)$  in probability with a convergence rate independent of  $y^n \in \mathcal{T}_{\varepsilon'}^n(Y)$ .  $\square$

### 2.2.3 Channels

Formally, a channel  $W$  is a conditional probability distribution depending on  $n$  inputs belonging to  $\mathcal{X}^n$  and  $m$  outputs belonging to  $\mathcal{Y}^m$ , so  $W := (W(y^m|x^n))_{x^n \in \mathcal{X}^n, y^m \in \mathcal{Y}^m}$  with:

$$\forall x^n, y^m, W(y^m|x^n) \geq 0 \text{ and } \forall x^n, \sum_{y^m \in \mathcal{Y}^m} W(y^m|x^n) = 1.$$

We will denote such a channel by  $W : \mathcal{X}^n \rightarrow \mathcal{Y}^m$ . The tensor product of two channels  $W : \mathcal{X}^n \rightarrow \mathcal{Y}^m$  and  $W' : \mathcal{X}'^m \rightarrow \mathcal{Y}'^m$  is denoted by  $W \otimes W' : (\mathcal{X}^n \times \mathcal{X}'^m) \rightarrow (\mathcal{Y}^m \times \mathcal{Y}'^m)$  and defined by:

$$(W \otimes W')(y^m y'^m | x^n x'^m) := W(y^m | x^n) \cdot W'(y'^m | x'^m).$$

We denote by  $W^{\otimes n}$  the  $n$ th tensor product of  $W$ , i.e.  $W^{\otimes n} = W \otimes \dots \otimes W$  with  $n$  occurrences of  $W$ .

When  $n = m = 1$ , we will speak of regular or point-to-point channels. When  $n > 1, m = 1$ , we will speak of multiple-access channels. When  $n = 1, m > 1$ , we will speak of broadcast channels. If both  $n, m$  are greater than 1, we will speak of interference channels. More specifically, in this thesis, we will focus on the cases of  $n = 2, m = 1$  and  $n = 1, m = 2$ , which are at the core of the specificity of network channels.

### 2.2.4 Capacity Regions

**Definition 2.12** (Capacity Region  $\mathcal{C}[\mathbb{S}](W)$  for a success probability  $\mathbb{S}(W, k_1, k_2)$ ). A rate pair  $(R_1, R_2)$  is  $\mathbb{S}$ -achievable (for the channel  $W$ ) if:

$$\lim_{n \rightarrow +\infty} \mathbb{S}(W^{\otimes n}, \lceil 2^{R_1 n} \rceil, \lceil 2^{R_2 n} \rceil) = 1.$$

We define the  $\mathbb{S}$ -capacity region  $\mathcal{C}[\mathbb{S}](W)$  as the closure of the set of all achievable rate pairs (for the channel  $W$ ).

**Definition 2.13** (Zero-error Capacity Region  $\mathcal{C}_0[\mathbb{S}](W)$  for  $\mathbb{S}(W, k_1, k_2)$ ). A rate pair  $(R_1, R_2)$  is  $\mathbb{S}$ -achievable with zero-error (for the channel  $W$ ) if:

$$\exists n_0 \in \mathbb{N}^*, \forall n \geq n_0, \mathbb{S}(W^{\otimes n}, \lceil 2^{R_1 n} \rceil, \lceil 2^{R_2 n} \rceil) = 1.$$

We define the zero-error  $\mathbb{S}$ -capacity region  $\mathcal{C}[\mathbb{S}](W)$  as the closure of the set of all achievable rate pairs with zero-error (for the channel  $W$ ).

**Proposition 2.15** (Time-sharing). *If the success probability  $\mathbb{S}$  satisfies:*

$$\forall W, W', \forall k_1, k_2, k'_1, k'_2, \mathbb{S}(W \otimes W', k_1 k'_1, k_2 k'_2) \geq \mathbb{S}(W, k_1, k_2) \cdot \mathbb{S}(W', k'_1, k'_2),$$

*then for all channels  $W$ ,  $\mathcal{C}[\mathbb{S}](W)$  and  $\mathcal{C}_0[\mathbb{S}](W)$  are convex.*

*Proof.* Let  $(R_1, R_2)$  and  $(R'_1, R'_2)$ , two pairs of  $\mathbb{S}$ -achievable rational rates for  $W$ , i.e.:

$$\mathbb{S}(W^{\otimes n}, \lceil 2^{R_1 n} \rceil, \lceil 2^{R_2 n} \rceil) \xrightarrow{n \rightarrow +\infty} 1 \text{ and } \mathbb{S}(W^{\otimes n}, \lceil 2^{R'_1 n} \rceil, \lceil 2^{R'_2 n} \rceil) \xrightarrow{n \rightarrow +\infty} 1.$$

Let  $\lambda \in (0, 1)$  rational and define  $R_{\lambda, i} := \lambda \cdot R_i + (1 - \lambda) \cdot R'_i$ , let us show that  $(R_{\lambda, 1}, R_{\lambda, 2})$  is achievable with non-signaling assistance. Let us call respectively  $k_i := 2^{R_i}, k'_i := 2^{R'_i}, k_{\lambda, i} := 2^{R_{\lambda, i}} = k_i^\lambda \cdot k_i^{(1-\lambda)}$ .

We have  $R_{\lambda, i} n = \lambda \cdot R_i n + (1 - \lambda) \cdot R'_i n = (\lambda n) \cdot R_i + (1 - \lambda)n \cdot R'_i$ . This is the idea of *time-sharing*: for  $\lambda n$  copies of the channel, we use the strategy with rate  $(R_1, R_2)$  and for the  $(1 - \lambda)n$  other copies of the channel, we use the strategy with rate  $(R'_1, R'_2)$ . There exists some  $n$  such that  $\lambda n, (1 - \lambda)n, \lambda n R_i, (1 - \lambda)n R'_i$  are integers, since everything is rational. This implies that  $k_i^{\lambda n}, k_i'^{(1-\lambda)n}, k_{\lambda, i}^n$  are integers. Thus, by hypothesis, we have that  $\mathbb{S}(W^{\otimes n}, k_{\lambda, 1}^n, k_{\lambda, 2}^n)$  is larger than or equal to:

$$\mathbb{S}(W^{\otimes (\lambda n)}, k_1^{\lambda n}, k_2^{\lambda n}) \cdot \mathbb{S}(W^{\otimes ((1-\lambda)n)}, k_1'^{(1-\lambda)n}, k_2'^{(1-\lambda)n}) \xrightarrow{n \rightarrow +\infty} 1 \cdot 1 = 1.$$

Thus, since  $\mathbb{S}(W^{\otimes n}, k_{\lambda, 1}^n, k_{\lambda, 2}^n) \leq 1$ , we get the result  $\mathbb{S}(W^{\otimes n}, k_{\lambda, 1}^n, k_{\lambda, 2}^n) \xrightarrow{n \rightarrow +\infty} 1$ , so  $(R_{\lambda, 1}, R_{\lambda, 2})$  is  $\mathbb{S}$ -achievable for the channel  $W$ . Finally, since  $\mathcal{C}[\mathbb{S}](W)$  is defined as the closure of  $\mathbb{S}$ -achievable rates for the channel  $W$ , we get that  $\mathcal{C}[\mathbb{S}](W)$  is convex.

For zero-error capacity regions, since by hypothesis there exists ranks  $n_0, n'_0$  such that  $\mathbb{S}(W^{\otimes n}, \lceil 2^{R_1 n} \rceil, \lceil 2^{R_2 n} \rceil) = 1$  for  $n \geq n_0$  and  $\mathbb{S}(W^{\otimes n}, \lceil 2^{R'_1 n} \rceil, \lceil 2^{R'_2 n} \rceil) = 1$  for  $n \geq n'_0$ , then in particular we get that for  $\lambda n \geq n_0$  and  $(1 - \lambda)n \geq n'_0$  that  $\mathbb{S}(W^{\otimes n}, k_{\lambda, 1}^n, k_{\lambda, 2}^n)$  is larger than or equal to:

$$\mathbb{S}(W^{\otimes (\lambda n)}, k_1^{\lambda n}, k_2^{\lambda n}) \cdot \mathbb{S}(W^{\otimes ((1-\lambda)n)}, k_1'^{(1-\lambda)n}, k_2'^{(1-\lambda)n}) = 1.$$



It is in particular true for  $n \geq n_0 := \max\left(\lceil \frac{n'_0}{1-\lambda} \rceil, \lceil \frac{n_0}{\lambda} \rceil\right)$ . As  $S^{\text{NS}}(W^{\otimes n}, k_{\lambda,1}^n, k_{\lambda,2}^n) \leq 1$ , we have for all  $n \geq n_0$  that  $S^{\text{NS}}(W^{\otimes n}, k_{\lambda,1}^n, k_{\lambda,2}^n) = 1$ , i.e.  $(R_{\lambda,1}, R_{\lambda,2})$  is S-achievable with zero-error for the channel  $W$ . Finally, since  $\mathcal{C}_0[\text{S}](W)$  is defined as the closure of S-achievable rates with zero-error for the channel  $W$ , we get that  $\mathcal{C}_0[\text{S}](W)$  is convex.  $\square$

## 2.3 Channel Coding for Point-to-Point Channels

We recall here the main results from [BF18] on channel coding for point-to-point channels, i.e. with one input and one output. Let us first recall the definition of the maximum success probability  $S(W, k)$  of transmitting  $k$  messages using the channel  $W$ :

$$\begin{aligned} S(W, k) := & \underset{e,d}{\text{maximize}} && \frac{1}{k} \sum_{i,x,y} W(y|x) e(x|i) d(i|y) \\ & \text{subject to} && \sum_{x \in \mathcal{X}} e(x|i) = 1, \forall i \in [k] \\ & && \sum_{j \in [k]} d(j|y) = 1, \forall y \in \mathcal{Y} \\ & && e(x|i), d(j|y) \geq 0 \end{aligned} \tag{2.6}$$

Then, the following characterization of  $S(W, k)$  can be derived:

**Proposition 2.16** (Proposition 2.1 of [BF18]).  $S(W, k) = \frac{1}{k} \max_{S \subseteq \mathcal{X}: |S| \leq k} f_W(S)$  with  $f_W(S) := \sum_{y \in \mathcal{Y}} \max_{x \in S} W(y|x)$ .

One can consider non-signaling assistance shared between the sender and the receiver, which leads to the following maximum success probability:

$$\begin{aligned} S^{\text{NS}}(W, k) := & \underset{P}{\text{maximize}} && \frac{1}{k} \sum_{i,x,y} W(y|x) P(xi|iy) \\ & \text{subject to} && \sum_x P(xj|iy) = \sum_x P(xj|i'y) \\ & && \sum_j P(xj|iy) = \sum_j P(xj|i'y') \\ & && \sum_{x,j} P(xj|iy) = 1 \\ & && P(xj|iy) \geq 0 \end{aligned} \tag{2.7}$$

A symmetrization can also be done to simplify the expression of the linear program defining  $S^{\text{NS}}(W, k)$ :

**Proposition 2.17** (Appendix A of [BF18]).

$$\begin{aligned}
S^{\text{NS}}(W, k) = & \underset{r, p}{\text{maximize}} && \frac{1}{k} \sum_{x, y} W(y|x) r_{x, y} \\
& \text{subject to} && \sum_x r_{x, y} = 1 \\
& && \sum_x p_x = k \\
& && 0 \leq r_{x, y} \leq p_x
\end{aligned} \tag{2.8}$$

Finally, the main tool we will use from [BF18] is the following random coding technique, which describes how to find a classical code with a success probability close to the non-signaling assisted one:

**Theorem 2.18** (Theorem 3.1 of [BF18]). *Given a solution  $r, p$  of the program computing  $S^{\text{NS}}(W, k)$ , we have that:*

$$\mathbb{E}_S \left[ \frac{f_W(S)}{\ell} \right] \geq \frac{k}{\ell} \left( 1 - \left( 1 - \frac{1}{k} \right)^\ell \right) \cdot \frac{1}{k} \sum_{x, y} W(y|x) r_{x, y},$$

for the multiset  $S$  obtained by choosing  $\ell$  elements of  $\mathcal{X}$  independently according to the distribution  $\left( \frac{p_x}{k} \right)_{x \in \mathcal{X}}$ .

# Tight Approximation Guarantees for Concave Coverage Problems

Coverage functions are central objects of study in combinatorial optimization. Problems related to optimizing such functions arise in multiple fields, such as operations research [CFN77], machine learning [FK14], algorithmic game theory [DV15], and information theory [BF18]. The most basic covering problem is the *maximum coverage* one. In this problem, we are given subsets  $T_1, \dots, T_m$  of a universe  $[n]$ , along with a positive integer  $k$ , and the objective is to find a size- $k$  subset  $S \subseteq [m]$  that maximizes the coverage function  $C(S) := |\bigcup_{i \in S} T_i|$ . A fundamental result in the field of approximation algorithms establishes that an approximation ratio of  $1 - e^{-1}$  can be achieved for this problem in polynomial time [Hoc97] and, in fact, this approximation guarantee is tight, under the assumption that  $P \neq NP$  [Fei98].

Note that in the maximum coverage problem, an element  $a \in [n]$  is counted at most once in the objective, even if  $a$  appears in several selected sets. However, if we think of elements  $a \in [n]$  as goods or resources, there are many settings wherein the utility indeed increases with the number of copies of  $a$  that get accumulated. Motivated, in part, by such settings, we consider a generalization of the maximum coverage problem where an element  $a$  can contribute by an amount that depends on the number of times it is covered.

Given a function  $\varphi : \mathbb{N} \rightarrow \mathbb{R}_+$ , an integer  $k \in \mathbb{N}$ , a universe of elements  $[n]$ , positive weights  $w_a$  for each  $a \in [n]$ , and subsets  $T_1, \dots, T_m \subseteq [n]$ , the  $\varphi$ -MAXCOVERAGE problem entails maximizing  $C^\varphi(S) := \sum_{a \in [n]} w_a \varphi(|S|_a)$  over subsets  $S \subseteq [m]$  of cardinality  $k$ ; here  $|S|_a = |\{i \in S : a \in T_i\}|$ .

This chapter focuses on functions  $\varphi$  that are nondecreasing and concave (i.e.,  $\varphi(i+2) - \varphi(i+1) \leq \varphi(i+1) - \varphi(i)$  for  $i \in \mathbb{N}$ ). We will also assume that the function  $\varphi$  is normalized in the sense that  $\varphi(0) = 0$  and  $\varphi(1) = 1$ .<sup>1</sup> Our approximation guarantees are in terms of the *Poisson concavity ratio* of  $\varphi$ , which we define as follows:

$$\alpha_\varphi := \inf_{x \in \mathbb{N}^*} \frac{\mathbb{E}[\varphi(\text{Poi}(x))]}{\varphi(\mathbb{E}[\text{Poi}(x)])} = \inf_{x \in \mathbb{N}^*} \frac{\mathbb{E}[\varphi(\text{Poi}(x))]}{\varphi(x)}. \quad (3.1)$$

<sup>1</sup>One can always replace a generic  $\varphi$  to a normalized one without changing the optimal solutions through a simple affine transformation.

Here  $\text{Poi}(x)$  denotes a Poisson-distributed random variable with parameter  $x$ . We will write  $\alpha_\varphi(x) := \frac{\mathbb{E}[\varphi(\text{Poi}(x))]}{\varphi(x)}$ , with  $\alpha_\varphi(0) = 1$ , and hence (see Proposition 3.18),  $\alpha_\varphi = \min_{x \in \mathbb{N}^*} \alpha_\varphi(x) = \inf_{x \in \mathbb{R}_+} \alpha_\varphi(x)$ .<sup>2</sup>

Our main result is that the  $\varphi$ -MAXCOVERAGE problem admits an efficient  $\alpha_\varphi$ -approximation algorithm, when  $\varphi$  is normalized nondecreasing concave, and this approximation guarantee is tight when  $\varphi$  grows sublinearly. Formally,

**Theorem 3.1.** *For any normalized nondecreasing concave function  $\varphi$ , there exists a  $\alpha_\varphi$ -approximation algorithm for the  $\varphi$ -MAXCOVERAGE problem running in polynomial time. Furthermore, for  $\varphi(n) = o(n)$ , it is NP-hard to approximate the  $\varphi$ -MAXCOVERAGE problem within a factor better than  $\alpha_\varphi + \varepsilon$ , for any constant  $\varepsilon > 0$ , even restricted to instances with unit weights and regular subsets.*

Before detailing the proof of the theorem, we provide a few remarks and connections to related work.

**Applications and related work** We can directly reduce the standard maximum coverage problem to  $\varphi$ -MAXCOVERAGE by setting  $\varphi(j) = \min(j, 1)$ . In this case  $\alpha_\varphi = 1 - e^{-1}$ . One can also encapsulate, within our framework, the  $\ell$ -MULTICOVERAGE problem studied in [BFGG20] by instantiating  $\varphi(j) = \min(j, \ell)$ . In this setting, we recover the approximation ratio  $\alpha_\varphi = 1 - \frac{\ell^\ell e^{-\ell}}{\ell!}$ , which matches the approximation guarantee obtained in [BFGG20] (see Proposition 3.31). Note that the hardness result in [BFGG20] was based on the unique games conjecture, whereas here we prove that this guarantee is tight under  $\text{P} \neq \text{NP}$ .

The initial motivation for studying  $\varphi$ -MAXCOVERAGE was to generalize the  $\ell$ -MULTICOVERAGE problem studied in [BFGG20] as well as its  $\ell$ -list-decoding interpretation. In the channel coding problem [BF18], we are given a noisy channel  $W(y|x)$ , defined as a conditional probability distribution, and the goal is to send a message chosen uniformly in  $[k]$  through this channel. In order to do so, the sender encodes the input message in  $\mathcal{X}$ , and the receiver decodes back the output of the channel from  $\mathcal{Y}$  to  $[k]$ . The objective is to find a code that maximize the probability of successfully decoding the message. In the  $\ell$ -list-decoding problem [Eli57, Woz58], instead of decoding the output into a single message, the decoder outputs a list of size  $\ell$  of possible messages, where  $\ell$  is some fixed parameter common to all lists. We consider that the decoding is successful if the initial message belongs to that list. The generalization of that problem, which we call the  $\varphi$ -list-decoding problem, allows decoding lists of any size. However, the decoding will be successful only with probability  $\frac{\varphi(\ell)}{\ell}$  when the initial message belongs to that list, where  $\ell$  is the size of that list. One can see that with a coverage function  $\varphi(j) = \min(j, \ell)$ , we recover the  $\ell$ -list-decoding problem. When the channel is of the form  $W(y|x) = \frac{1}{t}$  for  $y \in T_x$  with  $|T_x| = t$  and  $W(y|x) = 0$  elsewhere, the success probability of the  $\varphi$ -list-decoding problem for a code  $S \subseteq \mathcal{X}$  can be written as  $\frac{1}{kt} \sum_{y \in \mathcal{Y}} \varphi(|S|_y)$ , with  $|S|_y = |\{x \in S : y \in T_x\}|$ , which is a particular instance of the  $\varphi$ -MAXCOVERAGE problem; see Section 3.3.1 for further details. Therefore, for that class of channels, a tight approximation ratio  $\alpha_\varphi$  follows from Theorem 3.1.

---

<sup>2</sup>We require  $\varphi$  to be defined for nonnegative integers and will extend it over  $\mathbb{R}_+$  by considering its piecewise linear extension.

---

Another application of  $\varphi$ -MAXCOVERAGE is in the context of multiwinner elections that entail selecting  $k$  (out of  $m$ ) candidates with the objective of maximizing the cumulative utility of  $n$  voters; here, the utility of each voter  $a \in [n]$  increases as more and more approved (by  $a$ ) candidates get selected. One can reduce multiwinner elections to a coverage problem by considering subset  $T_i \subseteq [n]$  as the set of voters that approve of candidate  $i \in [m]$  and  $\varphi(j)$  as the utility that an agent achieves from  $j$  approved selections.<sup>3</sup> Addressing multiwinner elections in this standard utilitarian model, Dudycz et al. [DMMS20] obtain tight approximation guarantees for some well-studied classes of utilities. Specifically, the result in [DMMS20] applies to the classic *proportional approval voting rule*, which assigns a utility of  $\sum_{i=1}^j \frac{1}{i}$  for  $j$  approved selections. This voting rule corresponds to the coverage problem with  $\varphi(j) = \sum_{i=1}^j \frac{1}{i}$ , which we denote as the PROPORTIONAL APPROVAL VOTING problem (PAV for short). Section 3.3.2 shows that Theorem 3.1 holds for all the settings considered in [DMMS20] and, in fact, applies more generally. In particular, the voting version of  $\ell$ -MULTICOVERAGE (studied in [SFL16]) can be addressed by Theorem 3.1, but not by the result in [DMMS20]. Such a separation also arises when one truncates the proportional approval voting rule to, say,  $\ell$  candidates, i.e., upon setting  $\varphi(j) = \sum_{i=1}^{\min(j,\ell)} \frac{1}{i}$ . Given that multiwinner elections model multiple real-world settings (e.g., committee selection [SFL16] and parliamentary proceedings [BLS17]), instantiations of  $\varphi$ -MAXCOVERAGE in such social-choice contexts substantiate the applicability of our algorithmic result.

Coverage functions arise in numerous resource-allocation settings, such as sensor allocation [MW08], job scheduling, and plant location [CFN77]. The goal, broadly, in such setups is to select  $k$  subsets of resources (out of  $m$  pre-specified ones) such that the *welfare* generated by the selected resources is maximized—each resource’s contribution to the welfare increases with the number of times it is selected. This problem can be cast as  $\varphi$ -MAXCOVERAGE by setting  $n$  to be the number of resources,  $\{T_i\}_{i \in [m]}$  as the given collection of subsets, and  $\varphi(j)$  to be the welfare contribution of a resource when it is covered  $j$  times.<sup>4</sup> Here, we mention a specific allocation problem to highlight the relevance of studying  $\varphi$  beyond the standard coverage and  $\ell$ -coverage formulations (see Section 3.3.4 for details): in the VEHICLE-TARGET ASSIGNMENT problem [Mur00, PM18] (VTA for short) the resources are  $n$  targets and covering a target  $j$  times contributes  $\varphi^p(j) = \frac{1-(1-p)^j}{p}$  to the welfare; here,  $p \in (0, 1)$  is a given parameter. Interestingly, we find that for this problem, the approximation ratio  $\alpha_\varphi$  we obtain can outperform the *Price of Anarchy* (PoA), which corresponds to the approximation ratio of any method wherein the agents selfishly maximize their utilities (see Section 3.3.4 for further discussion of this point). By contrast, in the resource allocation problem with  $\varphi(j) = \min(j, \ell)$ , the price of anarchy is equal to  $\alpha_\varphi$ ; see [CPM19] for details. Another allocation problem studied in [PM18] corresponds to  $\varphi$ -MAXCOVERAGE with  $\varphi(j) = j^d$ , for a given parameter  $d \in (0, 1)$ . We refer to this instantiation as the  $d$ -POWER function.

Theorem 3.1 gives us a tight approximation bound of  $\alpha_\varphi$  for all the above-mentioned applications of  $\varphi$ -MAXCOVERAGE. The values of  $\alpha_\varphi$  for these instantiations are listed in Table 3.1.

---

<sup>3</sup>Indeed, for a subset of candidates  $S \subseteq [m]$ , the utility of a voter  $a \in [n]$  is equal to  $\varphi(|S|_a)$ , with  $|S|_a = |\{i \in S : a \in T_i\}|$ .

<sup>4</sup>Formally, to capture specific welfare-maximization problems in their entirety we have to consider  $\varphi$ -MAXCOVERAGE with a matroid constraint, and not just bound the number of selected subsets by  $k$ . Details pertaining to matroid constraints and the reduction appear in Section 3.1.1 and 3.3.3, respectively.

$\varphi$ -MAXCOVERAGE	$\varphi(j)$	$\alpha_\varphi$	Derivation
MAXCOVERAGE	$\min(j, 1)$	$1 - e^{-1}$	Prop. 3.31
$\ell$ -MULTICOVERAGE	$\min(j, \ell)$	$1 - \frac{\ell^\ell e^{-\ell}}{\ell!}$	Prop. 3.31
PAV	$\sum_{i=1}^j \frac{1}{i}$	$\alpha_\varphi(1) \simeq 0.7965 \dots$	Prop. 3.28
PAV capped at 3	$\sum_{i=1}^{\min(j,3)} \frac{1}{i}$	$\alpha_\varphi(1) \simeq 0.7910 \dots$	Prop. 3.21
$p$ -VTA	$\frac{1-(1-p)^j}{p}$	$\frac{1-e^{-p}}{p}$	Prop. 3.32
0.1-VTA	$\frac{1-(1-0.1)^j}{0.1}$	$\frac{1-e^{-0.1}}{0.1} \simeq 0.9516 \dots$	Prop. 3.32
0.1-VTA capped at 5	$\frac{1-(1-0.1)^{\min(j,5)}}{0.1}$	$\alpha_\varphi(5) \simeq 0.8470 \dots$	Prop. 3.21
$d$ -POWER	$j^d$	$e^{-1} \sum_{k=1}^{+\infty} \frac{k^d}{k!}$	Prop. 3.33

Table 3.1 – Tight approximation ratios for particular choices of  $\varphi$  in the  $\varphi$ -MAXCOVERAGE problem.

It is relevant to compare the approximation guarantee,  $\alpha_\varphi$ , obtained here with the approximation ratio based on the notion of curvature of submodular functions. Note that if  $\varphi$  is nondecreasing and concave, then  $C^\varphi$  is submodular. One can show, via a direct calculation, that for such a submodular  $C^\varphi$  the curvature (as defined in [CC84]) is given by  $c = 1 - (\varphi(m) - \varphi(m-1))$  for instances with at most  $m$  cover sets; see Proposition 3.19. Therefore, the algorithm of Sviridenko et al. [SVW17] provides an approximation ratio of  $1 - ce^{-1}$  for the  $\varphi$ -MAXCOVERAGE problem. We note that the Poisson concavity ratio  $\alpha_\varphi$  is always greater than or equal to this curvature-dependent ratio (Proposition 3.22). Specifically, for  $p$ -VEHICLE-TARGET ASSIGNMENT, it is strictly better for all  $p \notin \{0, 1\}$  and for  $\ell$ -MULTICOVERAGE, it is strictly better for all  $\ell \geq 2$  as remarked in [BFGG20]. Therefore, for the setting at hand, we improve the approximation guarantee obtained in [SVW17].

**Remarks on the Poisson concavity ratio  $\alpha_\varphi$ .** By Jensen’s inequality along with the nonnegativity and concavity of  $\varphi$ , we have that  $\alpha_\varphi \in [0, 1]$ . We show that  $\alpha_\varphi$  can be computed numerically up to any precision  $\varepsilon > 0$ , in time that is polynomial in  $\frac{1}{\varepsilon}$ . In fact, Proposition 3.17 shows that  $\alpha_\varphi(x) \geq 1 - \varepsilon$  for all  $x \geq N_\varepsilon := \lceil \left(\frac{6}{\varepsilon}\right)^4 \rceil$ . Thus, we can iterate over all  $x \in \{1, 2, \dots, N_\varepsilon\}$  and find  $\min_{x \in [N_\varepsilon]} \alpha_\varphi(x)$  up to  $\varepsilon$  precision (under reasonable assumptions on  $\varphi$ ). This gives us a method to overall compute  $\alpha_\varphi$ , up to an absolute error of  $2\varepsilon$ : if  $\alpha_\varphi \leq 1 - \varepsilon$ , then computing  $\min_{x \in [N_\varepsilon]} \alpha_\varphi(x)$  (up to  $\varepsilon$  precision) suffices. Otherwise, if  $\alpha_\varphi \geq 1 - \varepsilon$ , then  $\alpha_\varphi(1) \leq 1$  provides the desired bound. Furthermore, we note that Proposition 3.16 shows that even if we consider  $\alpha_\varphi(x)$  over all  $x \in \mathbb{R}_+$ , an infimum (i.e., the value of  $\alpha_\varphi$ ) is achieved at an integer.

**Further hardness under Gap-ETH** Theorem 3.1 shows that, under the assumption  $P \neq NP$ , no polynomial-time algorithm can approximate  $\varphi$ -MAXCOVERAGE within a better ratio than  $\alpha_\varphi$  for sublinear  $\varphi$ . One natural question that arises is whether relaxing the running time constraint helps. More precisely, since there are  $\binom{m}{k} = O(m^k)$  choices of  $k$  cover sets among the  $m$  available, a simple exhaustive search algorithm works in time  $O(m^k)$ . We can ask if FPT algorithms with respect to  $k$ , running in time  $f(k) \cdot m^{o(k)}$  with  $f$  an arbitrary function, can do better. As in [DMMS20], we use the result of [Man20] to show in Theorem 3.14 that such algorithms cannot approximate  $\varphi$ -MAXCOVERAGE within a better

ratio than  $\alpha_\varphi$  for sublinear  $\varphi$ , under the Gap-ETH hypothesis [CCK<sup>+</sup>17]; see Section 3.2.3 for more details. This means that the brute-force strategy is essentially the best, if one wants to get a better approximation ratio than  $\alpha_\varphi$ .

**Proof techniques and organization** In Section 3.1, we present our approximation algorithm for the  $\varphi$ -MAXCOVERAGE. The algorithm is an application of *pipage rounding*, a technique introduced in [AS04], on a linear programming relaxation of  $\varphi$ -MAXCOVERAGE. We show that the multilinear extension  $F^\varphi$  of  $C^\varphi$  is efficiently computable and thus, we can compute an integer solution  $x^{\text{int}}$  from the optimal fractional solution  $x^*$  satisfying  $C^\varphi(x^{\text{int}}) \geq F^\varphi(x^*)$ . Using the notion of *convex order* between distributions, we show that  $F^\varphi(x^*) \geq \sum_{a \in [n]} w_a \mathbb{E}[\varphi(\text{Poi}(|x^*|_a))]$ , where  $|x|_a = \sum_{i \in [m]: a \in T_i} x_i$ . Comparing this to the value  $\sum_{a \in [n]} w_a \varphi(|x^*|_a)$  taken by the linear program, we get a ratio given by the *Poisson concavity ratio*  $\alpha_\varphi$ . The concavity of  $\varphi$  is crucial at several steps of the proof: it guarantees that the natural relaxation can be written as a linear program, it is used to relate between sums of Bernoulli random variables and a Poisson random variable via the convex order, as well as for the fact that we can restrict the infimum in the definition of  $\alpha_\varphi$  to integer values of  $x$ . The generalization to matroid constraints follows in a standard way and is presented in Section 3.1.1.

In Section 3.2, we present the hardness result for  $\varphi$ -MAXCOVERAGE. For this, we define a generalization of the partitioning gadget of Feige [Fei98], extending also [BFGG20]. Roughly speaking, for an integer  $x_\varphi \in \mathbb{N}$ , it is a collection of  $x_\varphi$ -covers of the set  $[n]$  (an  $x$ -cover is a collection of subsets such that each element  $a \in [n]$  is covered  $x$  times, or in other words, its  $\varphi$ -coverage is  $\varphi(x)n$ ) that are incompatible in the sense that if we take an element from each one of these  $x_\varphi$ -covers, then the  $\varphi$ -coverage is bounded approximately by  $\mathbb{E}[\varphi(\text{Poi}(x_\varphi))]n$ . Then, we construct an instance of  $\varphi$ -MAXCOVERAGE from an instance of the NP-hard problem *Label Cover* (as in [DMMS20]) using such a gadget with  $x_\varphi \in \text{argmin}_{x \in \mathbb{N}} \alpha_\varphi(x)$ . Having set up the partitioning gadget, the analysis of the reduction can be obtained by carefully generalizing the reductions of [BFGG20] and [DMMS20].

In Section 3.3, we present different domains of application of our result.

### 3.1 Approximation Algorithm for $\varphi$ -MAXCOVERAGE

Fix a function  $\varphi : \mathbb{N} \rightarrow \mathbb{R}_+$  that is normalized, nondecreasing and concave. The  $\varphi$ -MAXCOVERAGE problem is defined as follows. The input to the problem is given by positive integers  $n, m, t$  and  $m$  subsets  $T_1, \dots, T_m$  of the set  $[n]$  (described as characteristic vectors), the weights  $w_a \in \mathbb{Q}_+$  for  $a \in [n]$  (described as a pair of bitstring of length  $t$ ), as well as an integer  $k \in \{1, \dots, m\}$ . The output is a subset  $S \subseteq [m]$  of size  $k$  that maximizes  $C^\varphi(S) = \sum_{a \in [n]} w_a \varphi(|S|_a)$ , where  $|S|_a = |\{i \in S : a \in T_i\}|$ .

Note that the input to this problem can be specified using  $n(m + 2t) + O(\log nmt)$  bits. To reduce the number of parameters, we will assume that  $t$  is polynomial in  $n$  and  $m$ , so that a polynomial-time algorithm for this problem means an algorithm that runs in time polynomial in  $n$  and  $m$ . The counting function  $\varphi$  is fixed and does not depend on the instance of the problem, but for a given instance the problem only depends on the values  $\varphi(0), \varphi(1), \dots, \varphi(m)$ . We assume that we have black box access to  $\varphi$  and to ensure that all the algorithms run in polynomial time, we assume that  $\varphi(j)$  can be described with

a number of bits that is polynomial in  $j$  and that this description can be computed in polynomial time.

We now describe the approximation algorithm for  $\varphi$ -MAXCOVERAGE that we analyze. As described above, we follow the standard relax and round strategy, as in [BFGG20]. First, we define a natural convex relaxation.

**Definition 3.1** (Relaxed program).

$$\begin{aligned}
 & \text{maximize} && \sum_{a \in [n]} w_a c_a \\
 & \text{subject to} && c_a \leq \varphi(|x|_a), \forall a \in [n], \text{ with } |x|_a := \sum_{i \in [m]: a \in T_i} x_i \\
 & && 0 \leq x_i \leq 1, \forall i \in [m] \\
 & && \sum_{i=1}^m x_i = k.
 \end{aligned} \tag{3.2}$$

As previously mentioned,  $\varphi$  is defined on  $\mathbb{R}_+$  by extending it in a piecewise linear fashion on non-integral points. As such, the constraint  $c_a \leq \varphi(|x|_a)$  is equivalent to  $m$  linear constraints. In fact, we can define  $\varphi_j$  to be the linear function  $\varphi_j(t) = (\varphi(j) - \varphi(j-1))t - (j-1)\varphi(j) + j\varphi(j-1)$  for  $j \in [m]$ . Since  $\varphi$  is concave, we have that for all  $t \in [0, m]$ ,  $\varphi(t) = \min_{j \in [m]} \varphi_j(t)$ . Thus, the constraint  $c_a \leq \varphi(|x|_a)$  is equivalent to  $c_a \leq \varphi_j(|x|_a)$  for all  $j \in [m]$  and so the program from Definition 3.1 can be stated as a linear program. Overall there are  $n + m$  variables and  $(n + 1)m + 1$  linear constraints, and by assumption all the coefficients can be described using a number of bits that is polynomial in  $n$  and  $m$ . Hence, an optimal solution of this linear program can be found in polynomial time.

Observe that the program from Definition 3.1 is indeed a relaxation of the  $\varphi$ -MAXCOVERAGE problem. To see this, given a set  $S$  of size  $k$ , consider the characteristic vector  $x \in \{0, 1\}^m$  defined by  $x_i = 1$  if and only if  $i \in S$ . Then for all  $a \in [n]$ , we can set  $c_a = \varphi(|x|_a) = \varphi(|S|_a)$ , and we get an objective value of  $\sum_{a \in [n]} w_a \varphi(|S|_a)$  which is exactly  $C^\varphi(S)$ . When solving the program from Definition 3.1, we get an optimal  $x^* \in [0, 1]^m$  which is in general not integral. Next, we describe a method to round it to an integral vector  $x^{\text{int}} \in \{0, 1\}^m$ .

**Rounding** For a submodular function  $f : \{0, 1\}^m \rightarrow \mathbb{R}$ , one can use pipage rounding [AS04, Von07, CCPV11] to transform, in polynomial time, any fractional solution  $x \in [0, 1]^m$  satisfying  $\sum_{i=1}^m x_i = k$  into an integral vector  $x^{\text{int}} \in \{0, 1\}^m$  such that  $\sum_{i=1}^m x_i^{\text{int}} = k$  and  $F(x^{\text{int}}) \geq F(x)$ , where  $F$  corresponds to the multilinear extension of  $f$ , provided that  $F(x)$  is computable in polynomial time for a given  $x$ ; see e.g., [Von07, Lemma 3.4]. The multilinear extension  $F : [0, 1]^m \rightarrow \mathbb{R}$  of  $f$  is defined by  $F(x_1, \dots, x_m) := \mathbb{E}[f(X_1, \dots, X_m)]$ , where  $X_i$  are independent random variables with  $X_i \sim \text{Ber}(x_i)$ , i.e.,  $X_i \in \{0, 1\}$  with  $\mathbb{P}(X_i = 1) = x_i$ . Note that  $F(x) = f(x)$  for an integral vector  $x \in \{0, 1\}^m$ .

We apply this strategy to  $C^\varphi$ , which is shown to be submodular in Proposition 3.19, and the solution  $x^*$  of the linear programming relaxation from Definition 3.1. Note that overall the algorithm runs in polynomial time, since here  $F(x)$  is computable in polynomial time for a given  $x$  (see Proposition 3.23). We now analyze the value returned by the



algorithm. Using the property of pipage rounding, with the notation  $X = (X_1, \dots, X_m)$  and  $\text{Ber}(x) = (\text{Ber}(x_1), \dots, \text{Ber}(x_m))$ , we get:

$$C^\varphi(x^{\text{int}}) = \mathbb{E}_{X \sim \text{Ber}(x^{\text{int}})}[C^\varphi(X)] \geq \mathbb{E}_{X \sim \text{Ber}(x^*)}[C^\varphi(X)].$$

Then, we only need to relate  $\mathbb{E}_{X \sim \text{Ber}(x^*)}[C^\varphi(X)]$  to the optimal value of the linear programming relaxation 3.1, which can only be larger than the optimal value of the  $\varphi$ -MAXCOVERAGE problem.

**Theorem 3.2.** *Let  $x, c$  be a feasible solution of the program from Definition 3.1 and let  $X \sim \text{Ber}(x)$ . Recalling the definition of  $\alpha_\varphi$  and  $\alpha_\varphi(j)$  from (3.1), we have*

$$\mathbb{E}_{X \sim \text{Ber}(x)}[C^\varphi(X)] \geq \left( \min_{j \in [m]} \alpha_\varphi(j) \right) \sum_{a \in [n]} w_a c_a.$$

*In particular, this implies that the described polynomial-time algorithm achieves an approximation ratio of  $\alpha_\varphi$ :*

$$C^\varphi(x^{\text{int}}) \geq \alpha_\varphi \sum_{a \in [n]} w_a c_a^* \geq \alpha_\varphi \max_{S \subseteq [m]: |S|=k} C^\varphi(S).$$

*Proof.* By linearity of expectation and the fact that the weights  $w_a$  are positive, it is sufficient to show that for all  $a \in [n]$ :

$$\mathbb{E}[C_a^\varphi(X)] \geq \left( \min_{j \in [m]} \alpha_\varphi(j) \right) c_a,$$

where  $C_a^\varphi(S) := \varphi(|S|_a)$ . Note that  $|X|_a = \sum_{i \in [m]: a \in T_i} X_i$ , and thus:

$$\begin{aligned} \mathbb{E}[C_a^\varphi(X)] &= \mathbb{E} \left[ \varphi \left( \sum_{i \in [m]: a \in T_i} X_i \right) \right] = \mathbb{E} \left[ \varphi \left( \sum_{i \in [m]: a \in T_i} \text{Ber}(x_i) \right) \right] \\ &\geq \mathbb{E} \left[ \varphi \left( \text{Poi} \left( \sum_{i \in [m]: a \in T_i} x_i \right) \right) \right] \text{ thanks to Proposition 2.2} \\ &= \mathbb{E}[\varphi(\text{Poi}(|x|_a))] \geq \min(\alpha_\varphi(\lfloor |x|_a \rfloor), \alpha_\varphi(\lceil |x|_a \rceil)) \varphi(|x|_a) \\ &\quad \text{thanks to Proposition 3.16} \\ &\geq \left( \min_{j \in [m]} \alpha_\varphi(j) \right) \varphi(|x|_a) \geq \left( \min_{j \in [m]} \alpha_\varphi(j) \right) c_a. \end{aligned} \tag{3.3}$$

□

### 3.1.1 Generalization to Matroid Constraints

Instead of taking a cardinality constraint  $k$  on the size of the subset  $S$ , we look now at general matroid constraints on  $S$ . Specifically, as input, instead of  $k$ , we take a matroid  $\mathcal{M}$  defined on  $[m]$  and given by a set of linear constraints describing its base polytope  $B(\mathcal{M})$ .

The output is a set  $S \in \mathcal{M}$  that maximizes  $C^\varphi(S)$ . Note that the cardinality constraint considered above is the special case where  $\mathcal{M}$  is the uniform matroid (composed of all subsets of size at most  $k$ ) with its base polytope  $B(\mathcal{M}) = \{x \in [0, 1]^m : \sum_{i=1}^m x_i = k\}$ .

We note that in order to establish Theorem 3.2, the cardinality constraint  $\sum_{i=1}^m x_i = k$  is not used. Thus, since the pipage rounding strategy applies to matroid constraints  $\mathcal{M}$  (see [Von07, Lemma 3.4]), the strategy and the analysis of its efficiency generalize immediately when applied to the following linear program:

**Definition 3.2** (Relaxed program for matroid constraints).

$$\begin{aligned} & \text{maximize} && \sum_{a \in [n]} w_a c_a \\ & \text{subject to} && c_a \leq \varphi(|x|_a), \forall a \in [n] \\ & && 0 \leq x_i \leq 1, \forall i \in [m] \\ & && x \in B(\mathcal{M}) \quad \text{the base polytope of } \mathcal{M}. \end{aligned} \tag{3.4}$$

**Theorem 3.3.** *Let  $x, c$  a feasible solution of the program from Definition 3.2 and  $X \sim \text{Ber}(x)$ . Then:*

$$\mathbb{E}_{X \sim \text{Ber}(x)}[C^\varphi(X)] \geq \left( \min_{j \in [m]} \alpha_\varphi(j) \right) \sum_{a \in [n]} w_a c_a.$$

*In particular, this implies that the described polynomial-time algorithm achieves an approximation ratio of  $\alpha_\varphi$ :*

$$C^\varphi(x^{\text{int}}) \geq \alpha_\varphi \sum_{a \in [n]} w_a c_a^* \geq \alpha_\varphi \max_{S \in \mathcal{M}} C^\varphi(S).$$

### 3.2 Hardness of Approximation for $\varphi$ -MAXCOVERAGE

In this section, we establish an inapproximability result for the  $\varphi$ -MAXCOVERAGE problem with unit weights and regular subsets under cardinality constraints. Throughout this section, we use  $\Gamma$  to denote the universe of elements and, hence, an instance of the  $\varphi$ -MAXCOVERAGE problem consists of  $\Gamma$ , along with a collection of regular subsets  $\mathcal{F} = \{F_i \subseteq \Gamma\}_{i=1}^m$  (i.e.  $\forall i \in [m], |F_i| = t$  for some  $t$ ) and an integer  $k$ . Recall that the objective of this problem is to find a size- $k$  subset  $S \subseteq \Gamma$  that maximizes  $C^\varphi(S) = \sum_{a \in \Gamma} \varphi(|S|_a)$ .

We establish the following theorem in this section:

**Theorem 3.4.** *It is NP-hard to approximate the  $\varphi$ -MAXCOVERAGE problem for  $\varphi(n) = o(n)$  within a factor greater than  $\alpha_\varphi + \varepsilon$  for any  $\varepsilon > 0$ , even restricted to instances with unit weights and regular subsets.*

Our reduction is based on a problem called  $h$ -ARYLABELCOVER, which is equivalent to the more standard GAPLABELCOVER problem as will be shown in Appendix 3.5.3.

**Definition 3.3** ( $h$ -ARYLABELCOVER). An instance  $\mathcal{G} = (V, E, [L], [R], \{\pi_{e,v}\}_{e \in E, v \in e})$  of  $h$ -ARYLABELCOVER is characterized by an  $h$ -uniform regular hypergraph  $(V, E)$  and constraints  $\pi_{e,v} : [L] \rightarrow [R]$ . Here, each  $h$ -uniform hyperedge represents a  $h$ -ary constraint. Additionally, for any labeling  $\sigma : V \rightarrow [L]$ , we have the following notions of strongly and weakly satisfied constraints:

- An edge  $e = (v_1, \dots, v_h) \in E$  is *strongly satisfied* by  $\sigma$  if:

$$\forall x, y \in [h], \pi_{e,v_x}(\sigma(v_x)) = \pi_{e,v_y}(\sigma(v_y)) .$$

- An edge  $e = (v_1, \dots, v_h) \in E$  is *weakly satisfied* by  $\sigma$  if:

$$\exists x \neq y \in [h], \pi_{e,v_x}(\sigma(v_x)) = \pi_{e,v_y}(\sigma(v_y)) .$$

**Proposition 3.5** ( $\delta, h$ -ARYGAPLABELCOVER). For any fixed integer  $h \geq 2$  and fixed  $\delta > 0$ , there exists an  $R_0$  such that for any integer  $R \geq R_0$ , it is NP-hard for all instances  $\mathcal{G} = (V, E, [L], [R], \{\pi_{e,v}\}_{e \in E, v \in e})$  of  $h$ -ARYLABELCOVER with right alphabet  $[R]$  to distinguish between:

**YES:** There exists a labeling  $\sigma$  that strongly satisfies all the edges.

**NO:** No labeling weakly satisfies more than  $\delta$  fraction of the edges.

### 3.2.1 Partitioning System

In order to prove Theorem 3.4, we will need to generalize the partitioning system of Feige [Fei98], a constant-size combinatorial object used to prove complexity hardness results. Note that it was already generalized in [BFGG20], over which we base our version. For any set  $[n]$  and  $\mathcal{Q} \subseteq 2^{[n]}$ , we overload the definition  $C^\varphi(\mathcal{Q}) := \sum_{a \in [n]} \varphi(|\mathcal{Q}|_a)$  with the notations  $|\mathcal{Q}|_a := |\{P \in \mathcal{Q} : a \in P\}|$  and  $C_a^\varphi(\mathcal{Q}) := \varphi(|\mathcal{Q}|_a)$ . Let us take  $x_\varphi \in \operatorname{argmin}_{x \in \mathbb{N}^*} \alpha_\varphi(x)$ , thus  $\alpha_\varphi = \alpha_\varphi(x_\varphi)$ .

We say that  $\mathcal{Q}$  is an  $x$ -cover of  $x \in \mathbb{N}$  if every element of  $[n]$  is covered  $x$  times, so  $C^\varphi(\mathcal{Q}) = n\varphi(x)$ .

**Definition 3.4.** An  $([n], h, R, \varphi, \eta)$ -partitioning system consists of  $R$  collections of subsets of  $[n]$ ,  $\mathcal{P}_1, \dots, \mathcal{P}_R \subseteq 2^{[n]}$ , that satisfy  $\frac{x_\varphi n}{h} \in \mathbb{N}$ ,  $x_\varphi \geq h$  and:

1. For every  $i \in [R]$ ,  $\mathcal{P}_i$  is a collection of  $h$  subsets  $P_{i,1}, \dots, P_{i,h} \subseteq [n]$  each of size  $\frac{x_\varphi n}{h}$  which is an  $x_\varphi$ -cover.
2. For any  $T \subseteq [R]$  and  $\mathcal{Q} = \{P_{i,j(i)} : i \in T\}$  for some function  $j : T \rightarrow [h]$ , we have  $|C^\varphi(\mathcal{Q}) - \psi_{|T|,h}^\varphi n| \leq \eta n$  where:

$$\psi_{k,h}^\varphi := \mathbb{E} \left[ \varphi \left( \operatorname{Bin} \left( k, \frac{x_\varphi}{h} \right) \right) \right] . \quad (3.5)$$

*Remark.* In particular, for any  $\mathcal{Q} = \{Q_1, \dots, Q_k\}$  with  $Q_i$  of size  $\frac{x_\varphi n}{h}$ , we have that  $C^\varphi(\mathcal{Q}) \leq n\varphi(k\frac{x_\varphi}{h})$ . Indeed  $C^\varphi(\mathcal{Q}) = \sum_{a \in [n]} \varphi(|\mathcal{Q}|_a)$  with  $\sum_{a \in [n]} |\mathcal{Q}|_a = \sum_{i \in [k]} |Q_i| = k \cdot \frac{x_\varphi n}{h}$ . By concavity of  $\varphi$  and Jensen's inequality, this function is maximized when all  $|\mathcal{Q}|_a$  are equals, where we get  $n\varphi(k\frac{x_\varphi}{h})$ .

**Proposition 3.6.** *For every choice of  $R, h \in \mathbb{N}$  with*

$$h \geq x_\varphi, \eta \in (0, 1), n \geq \eta^{-2} R \varphi(R)^2 \log(20(h+1))$$

*such that  $\frac{x_\varphi n}{h} \in \mathbb{N}$ , there exists a  $([n], h, R, \varphi, \eta)$ -partitioning system, which can be found in time  $\exp(Rn \log(n)) \cdot \text{poly}(h)$ .*

The proof can be found in Appendix 3.5.4.

### 3.2.2 The Reduction

*Proof of Theorem 3.4.* Let  $\varepsilon > 0$ . Without loss of generality, we can assume that  $\varepsilon < 1$ . We show that it is NP-hard to reach an approximation ratio greater than  $\alpha_\varphi + \varepsilon$  for the  $\varphi$ -MAXCOVERAGE problem, via a reduction from  $\delta, h$ -ARYGAPLABELCOVER.

- $\eta = \frac{\varphi(x_\varphi)}{4x_\varphi} \varepsilon$ , so  $0 < \eta \leq \varepsilon < 1$ ,
- $h \geq x_\varphi$  such that  $|\psi_{h,h}^\varphi - \alpha_\varphi \varphi(x_\varphi)| \leq \eta$  (see (3.5) for the definition of  $\psi^\varphi$ ); such a choice exists thanks to Proposition 3.24,
- $\theta$  such that for all  $x \geq \theta$ ,  $\frac{\varphi(x)}{x} \leq \eta$ , which exists since  $\varphi(x) = o(x)$ ,
- $\xi = \frac{x_\varphi}{\theta}$ ,
- $\delta = \frac{\eta \xi^3}{2 h^2}$ ,
- $R \geq h$  large enough for Proposition 3.5 to hold.

Then, given an instance  $\mathcal{G} = (V, E, [L], [R], \Sigma, \{\pi_{e,v}\}_{e \in E, v \in e})$  of  $\delta, h$ -ARYGAPLABELCOVER, we construct an instance  $(\Gamma, \mathcal{F}, k)$  of the  $\varphi$ -MAXCOVERAGE problem with:

- $n$  a large enough integer to have the existence of  $([n], h, R, \varphi, \eta)$ -partitioning systems using Proposition 3.6. Note that the size of these partitioning systems is independent of the size of the instance  $\mathcal{G}$  and that we can construct such a partitioning system in constant time (with relation to the size of the instance  $\mathcal{G}$ ) thanks to Proposition 3.6.
- $\Gamma = [n] \times E$ ,
- $k = |V|$ ,
- Consider a  $([n], h, R, \varphi, \eta)$ -partitioning system, and call  $\mathcal{P} = \{\mathcal{P}_1, \dots, \mathcal{P}_R\}$  the corresponding set of collections. Define sets  $T_\beta^{e,v_j} := P_{\pi_{e,v_j}(\beta), j} \times \{e\}$  where  $e = (v_1, \dots, v_h) \in E, j \in [h], \beta \in [L]$ . Then, take  $F_\beta^v := \bigsqcup_{e \in E: v \in e} T_\beta^{e,v}$  as cover sets and  $\mathcal{F} := \{F_\beta^v, v \in V, \beta \in [L]\}$ . Note that  $|F_\beta^v| = \sum_{e \in E: v \in e} |T_\beta^{e,v}| = \sum_{e \in E: v \in e} |P_{\pi_{e,v_j}(\beta), j}| = |\{e \in E : v \in e\}| \cdot \frac{x_\varphi n}{h}$  which does not depend on  $v$  as the hypergraph  $(V, E)$  is regular. Therefore, those subsets are indeed regular.

We will now prove that if we are in a YES instance, we have that there exists  $\mathcal{T}$  of size  $k$  such that  $C^\varphi(\mathcal{T}) \geq \varphi(x_\varphi)|\Gamma|$  (completeness). Moreover, if we are in a NO instance, then we have that for all  $\mathcal{T}$  of size  $k = |V|$ ,  $C^\varphi(\mathcal{T}) \leq (\alpha_\varphi + \varepsilon)\varphi(x_\varphi)|\Gamma|$  (soundness). Establishing these two properties would conclude the proof. In fact, an algorithm for  $\varphi$ -MAXCOVERAGE achieving a factor strictly greater than  $\alpha_\varphi + \varepsilon$  would allow us to decide whether we have YES or a NO instance of the NP-hard problem  $\delta$ ,  $h$ -ARYGAPLABELCOVER.

In order to achieve this, let us define  $C^{\varphi,e} := \sum_{a \in [n] \times \{e\}} C_a^\varphi$ . In particular, we have  $C^\varphi = \sum_{a \in \Gamma} C_a^\varphi = \sum_{e \in E} C^{\varphi,e}$ . For  $\mathcal{T} \subseteq \mathcal{F}$ , we define the relevant part of  $\mathcal{T}$  on  $e$  by:

$$\mathcal{T}_e := \{T_\beta^{e,v} : v \in e, \beta \in [L], F_\beta^v \in \mathcal{T}\} = \{F_\beta^v \cap ([n] \times \{e\}), F_\beta^v \in \mathcal{T}\}.$$

Note that  $C^{\varphi,e}(\mathcal{T}) = C^{\varphi,e}(\mathcal{T}_e)$ , and in particular  $C^\varphi(\mathcal{T}) = \sum_{e \in E} C^{\varphi,e}(\mathcal{T}_e)$ .

### 3.2.2.1 Completeness

Suppose the given  $h$ -ARYLABELCOVER instance  $\mathcal{G}$  is a YES instance. Then, there exists a labeling  $\sigma : V \mapsto [L]$  which strongly satisfies all edges. Consider the collection of  $|V|$  subsets  $\mathcal{T} := \{F_{\sigma(v)}^v : v \in V\}$ . Fix  $e = (v_1, \dots, v_h) \in E$ . Since  $e$  is strongly satisfied by  $\sigma$ , there exists  $r \in [R]$  such that  $\pi_{e,v_i}(\sigma(v_i)) = r$  for all  $i \in [h]$ . Therefore, we get that  $\mathcal{T}_e = \{T_{\sigma(v_i)}^{e,v_i}\}_{i \in [h]} = \{P_{r,i} \times \{e\}\}_{i \in [h]}$  is an  $x_\varphi$ -cover of  $[n] \times \{e\}$ , and so  $C^{\varphi,e}(\mathcal{T}_e) = n\varphi(x_\varphi)$ . Thus  $C^\varphi(\mathcal{T}) = \sum_{e \in E} C^{\varphi,e}(\mathcal{T}_e) = |E|\varphi(x_\varphi)n = \varphi(x_\varphi)|\Gamma|$ .

### 3.2.2.2 Soundness

Suppose the given  $h$ -ARYLABELCOVER instance  $\mathcal{G}$  is a NO instance. Let us prove the contrapositive of the soundness: we suppose that there exists  $\mathcal{T}$  of size  $k = |V|$  such that  $C^\varphi(\mathcal{T}) > (\alpha_\varphi + \varepsilon)\varphi(x_\varphi)|\Gamma|$ . Let us show that there exists a labeling  $\sigma$  that weakly satisfies a strictly larger fraction of the edges than  $\delta$ .

For every vertex  $v \in V$ , we define  $L(v) := \{\beta \in [L] : F_\beta^v \in \mathcal{T}\}$  to be the candidate set of labels that can be associated with the vertex  $v$ . We extend this definition to hyperedges  $e = (v_1, \dots, v_h)$  where we define  $L(e) := \bigcup_{i \in [h]} L(v_i)$  to be the *multiset* of all labels associated with the edge. Note that  $|\mathcal{T}_e| = |L(e)|$ .

We say that  $e = (v_1, \dots, v_h) \in E$  is *consistent* if and only if there exists  $x \neq y \in [h]$  such that  $\pi_{e,v_x}(L(v_x)) \cap \pi_{e,v_y}(L(v_y)) \neq \emptyset$ . We then decompose  $E$  in three parts:

- $B$  is the set of edges  $e \in E$  with  $|L(e)| \geq \frac{h}{\xi}$ .
- $N$  is the set of consistent edges  $e \in E$  with  $|L(e)| < \frac{h}{\xi}$ .
- $I = E - (B \cup N)$  is the set of inconsistent edges  $e \in E$  with  $|L(e)| < \frac{h}{\xi}$ .

We want to show that the contribution of  $N$  is not too small, which we will use to construct a labeling weakly satisfying enough edges. This comes from the following lemmas:

**Lemma 3.7.**  $\sum_{e \in E} |L(e)| = |E|h$

*Proof.* Recall that our  $h$ -uniform hypergraph is regular; call  $d$  its regular degree. In particular, we have that  $d|V| = |E|h$ . Note also that  $\sum_{v \in V} |L(v)| = |\mathcal{T}| = |V|$ . Thus:

$$\sum_{e \in E} |L(e)| = \sum_{e \in E} \sum_{v \in V: v \in e} |L(v)| = \sum_{v \in V} \sum_{e \in E: v \in e} |L(v)| = d \sum_{v \in V} |L(v)| = d|V| = |E|h.$$

□

Next, we bound the contribution of  $B$ :

**Lemma 3.8.**  $\sum_{e \in B} C^{\varphi, e}(\mathcal{T}_e) \leq \frac{\varepsilon}{4} \varphi(x_\varphi) |\Gamma|$ .

*Proof.* We have:

$$\begin{aligned} \sum_{e \in B} C^{\varphi, e}(\mathcal{T}_e) &\leq \sum_{e \in B} n_\varphi \left( |L(e)| \frac{x_\varphi}{h} \right) \quad \text{by remark on Definition 3.4 and } |\mathcal{T}_e| = |L(e)| \\ &\leq |B| \cdot n_\varphi \left( \frac{\sum_{e \in B} |L(e)|}{|B|} \frac{x_\varphi}{h} \right) \quad \text{by Jensen's inequality on concave } \varphi \\ &\leq |B| \cdot n_\varphi \left( \frac{|E|h}{|B|} \frac{x_\varphi}{h} \right) \\ &\quad \text{since } \varphi \text{ nondecreasing and } \sum_{e \in B} |L(e)| \leq |E|h \text{ by Lemma 3.7} \\ &= \frac{\varphi \left( \frac{|E|x_\varphi}{|B|} \right)}{\frac{|E|x_\varphi}{|B|}} x_\varphi |\Gamma|. \end{aligned} \tag{3.6}$$

We have seen that  $\sum_{e \in B} |L(e)| \leq |E|h$ , but  $\sum_{e \in B} |L(e)| \geq |B| \frac{h}{\xi}$  by definition of  $B$ , so we have that  $\frac{|B|}{|E|} \leq \xi$ . Thus  $\frac{|E|x_\varphi}{|B|} \geq \frac{x_\varphi}{\xi} = \theta$ . By definition of  $\theta$ , we get that:

$$\sum_{e \in B} C^{\varphi, e}(\mathcal{T}_e) \leq \eta x_\varphi |\Gamma| = \frac{\varepsilon}{4} \varphi(x_\varphi) |\Gamma|.$$

□

In order to bound the contribution of  $I$ , we will prove a property on inconsistent edges:

**Proposition 3.9.** *Let  $e = (v_1, \dots, v_h) \in E$  be an inconsistent hyperedge with respect to  $\mathcal{T}$ . Then we have that  $\left| C^{\varphi, e}(\mathcal{T}_e) - \psi_{|L(e)|, h}^\varphi \right| \leq \eta n$ .*

*Proof.* Since  $e$  is inconsistent,  $\forall x \neq y \in [h], \pi_{e, v_x}(L(v_x)) \cap \pi_{e, v_y}(L(v_y)) = \emptyset$ . Therefore, for every  $i \in [R]$ , there is at most one  $v \in e$  such that  $i \in \pi_{e, v}(L(v))$ , i.e.,  $\mathcal{T}_e$  intersects with  $\mathcal{P}_i \times \{e\}$  in at most one subset. This gives us a subset  $T \subseteq [R]$  and a function  $j : T \rightarrow [h]$  such that  $\mathcal{T}_e = \{P_{i, j(i)} \times \{e\} : i \in T\}$ . As a consequence,  $|T| = |\mathcal{T}_e| = |L(e)|$  and by the second condition of the partitioning system, we get the expected result. □

Now, we can bound the contribution of  $I$ :

**Lemma 3.10.**  $\sum_{e \in I} C^{\varphi, e}(\mathcal{T}_e) \leq (\alpha_\varphi + \frac{\varepsilon}{2}) \varphi(x_\varphi) |\Gamma|$ .

*Proof.* Thanks to Proposition 3.9, we have:

$$\sum_{e \in I} C^{\varphi, e}(\mathcal{T}_e) \leq \sum_{e \in I} (\psi_{|L(e)|, h}^{\varphi} + \eta)n \leq \sum_{e \in E} (\psi_{|L(e)|, h}^{\varphi} + \eta)n,$$

since  $I \subseteq E$  and  $\psi_{|L(e)|, h}^{\varphi} \geq 0$ . But  $\sum_{e \in E} |L(e)| = |E|h$  by Lemma 3.7 and  $x \mapsto \psi_{x, h}^{\varphi}$  is concave thanks to Proposition 3.26, so we can use Jensen's inequality to get:

$$\sum_{e \in E} \psi_{|L(e)|, h}^{\varphi} \leq |E| \psi_{\frac{\sum_{e \in E} |L(e)|}{|E|}, h}^{\varphi} = |E| \psi_{h, h}^{\varphi},$$

and thus:

$$\sum_{e \in I} C^{\varphi, e}(\mathcal{T}_e) \leq (\psi_{h, h}^{\varphi} + \eta)n|E| \leq (\alpha_{\varphi} \varphi(x_{\varphi}) + 2\eta)|\Gamma|,$$

by definition of  $h$ . This implies that the total contribution of inconsistent edges  $I$  is at most:

$$\sum_{e \in I} C^{\varphi, e}(\mathcal{T}_e) \leq (\alpha_{\varphi} \varphi(x_{\varphi}) + 2\eta)|\Gamma| \leq (\alpha_{\varphi} + \frac{\varepsilon}{2})\varphi(x_{\varphi})|\Gamma|,$$

by definition of  $\eta$ . □

**Lemma 3.11.**  $\frac{|N|}{|E|} \geq \xi\eta$ .

*Proof.* Since we have supposed that  $\sum_{e \in E} C^{\varphi, e}(\mathcal{T}_e) = C^{\varphi}(\mathcal{T}) > (\alpha_{\varphi} + \varepsilon)\varphi(x_{\varphi})|\Gamma|$ , and with the help of Lemmas 3.8 and 3.10, we have that the contribution of  $N$  is:

$$\sum_{e \in N} C^{\varphi, e}(\mathcal{T}_e) > \frac{\varepsilon}{4}\varphi(x_{\varphi})|\Gamma|.$$

However, we have that for  $e \in N$  that:

$$C^{\varphi, e}(\mathcal{T}_e) \leq n\varphi\left(|\mathcal{T}_e| \frac{x_{\varphi}}{h}\right) = n\varphi\left(|L(e)| \frac{x_{\varphi}}{h}\right) \leq n\varphi\left(\frac{x_{\varphi}}{\xi}\right) \leq \frac{nx_{\varphi}}{\xi},$$

thanks to the remark on Definition 3.4 and the bound  $|L(e)| < \frac{h}{\xi}$ . This implies that:

$$\frac{|N|}{|E|} \geq \frac{\xi}{x_{\varphi}} \frac{\varepsilon\varphi(x_{\varphi})}{4} = \xi\eta.$$

□

Finally, we construct a randomized labeling  $\sigma : V \mapsto [L]$  as follows: for  $v \in V$ , if  $L(v) \neq \emptyset$ , set  $\sigma(v)$  uniformly from  $L(v)$ , otherwise set it arbitrarily. We claim that in expectation, this labeling must weakly satisfy  $\delta$  fraction of the hyperedges.

To see this, fix any  $e = (v_1, \dots, v_h) \in N$ . Thus, there exists  $\exists x \neq y \in [h]$  such that  $\pi_{e, v_x}(L(v_x)) \cap \pi_{e, v_y}(L(v_y)) \neq \emptyset$ . Furthermore  $|L(v_x)|, |L(v_y)| \leq \frac{h}{\xi}$ . Thus, we have that  $\pi_{e, v_x}(L(v_x)) = \pi_{e, v_y}(L(v_y))$  with probability at least  $\frac{1}{|L(v_x)||L(v_y)|} \geq \left(\frac{\xi}{h}\right)^2$ . Therefore:

$$\begin{aligned} \mathbb{E}_{\sigma} \mathbb{E}_{e \sim E} [\sigma \text{ weakly satisfies } e] &\geq \xi\eta \mathbb{E}_{\sigma} \mathbb{E}_{e \sim E} [\sigma \text{ weakly satisfies } e | e \in N] \quad \text{by Lemma 3.11} \\ &> \frac{\eta \xi^3}{2 h^2} = \delta. \end{aligned} \tag{3.7}$$

In particular, there exists some labeling  $\sigma$  such that  $\mathbb{E}_{e \sim E} [\sigma \text{ weakly satisfies } e] > \delta$ , thus the soundness is proved. □

Furthermore, the previous proof implies an additive inapproximability result:

**Corollary 3.12.** *There is no additive polynomial-time approximation scheme (PTAS) for the  $\varphi$ -MAXCOVERAGE problem for  $\varphi(n) = o(n)$  and  $\alpha_\varphi < 1$  if  $P \neq NP$ ; that is to say, a polynomial-time approximation that achieves an additive approximation error of  $\varepsilon \cdot n$ , with  $n$  the size of the universe, for all  $\varepsilon > 0$ .*

*Remark.* Contrary to fully polynomial-time approximation schemes (FPTAS), a PTAS does not necessarily run in polynomial time in  $\frac{1}{\varepsilon}$ .

*Proof.* Let us fix  $\varepsilon := \frac{1-\alpha_\varphi}{3}\varphi(x_\varphi) > 0$ , which does not depend on the instance of the  $\varphi$ -MAXCOVERAGE problem. Assume for the sake of contradiction that we have a polynomial-time approximation that achieves an additive approximation error of  $\varepsilon \cdot n$ , with  $n$  the size of the universe. In the previous proof (with the former  $\varepsilon$  defined in Section 3.2.2 chosen equal to  $\frac{1-\alpha_\varphi}{3}$ ), with such an additive approximation algorithm, one could distinguish between YES and NO instances of  $\delta, h$ -ARYGAPLABELCOVER. Indeed, a YES instance implies that the associated  $\varphi$ -MAXCOVERAGE instance has a solution of value  $\varphi(x_\varphi)|\Gamma|$ , where  $\Gamma$  is the universe in that setting. On the other hand, a NO instance implies that all solutions of the associated  $\varphi$ -MAXCOVERAGE instance have a value smaller than or equal to  $\frac{1+2\alpha_\varphi}{3}\varphi(x_\varphi)|\Gamma|$ . Therefore, on a YES instance, our approximation algorithm would output a solution with a value larger than or equal to  $\frac{2+\alpha_\varphi}{3}\varphi(x_\varphi)|\Gamma|$ . This resulting inequality is enough to guarantee that it does not come from a NO instance, as it is strictly larger than  $\frac{1+2\alpha_\varphi}{3}\varphi(x_\varphi)|\Gamma|$  since  $\alpha_\varphi < 1$ . Thus, such an approximation algorithm would allow us to solve  $\delta, h$ -ARYGAPLABELCOVER in polynomial time, which is impossible if  $P \neq NP$ .  $\square$

### 3.2.3 Further Hardness Under Gap-ETH

The Gap Exponential Time Hypothesis (Gap-ETH for short) states that, for some constant  $\delta > 0$ , there is no  $2^{o(n)}$ -time algorithm that, given  $n$ -variable 3-SAT formula, can distinguish whether the formula is fully satisfiable or that it is not even  $(1 - \delta)$ -satisfiable. Gap-ETH is a standard assumption in proving FPT hardness of approximation (see e.g. [CCK<sup>+</sup>17]). Under such hypothesis, Manurangsi showed the following theorem:

**Theorem 3.13** ([Man20], adapted to  $(\delta, h)$ -ARYGAPLABELCOVER). *Assuming Gap-ETH, for every  $\delta > 0$ , every  $h \in \mathbb{N}, h \geq 2$  and any sufficiently large  $R \in \mathbb{N}$  (depending on  $\delta, h$ ), no  $f(k) \cdot N^{o(k)}$ -time algorithm can solve  $(\delta, h)$ -ARYGAPLABELCOVER with right alphabet  $[R]$ , where  $k$  denotes the number of vertices in  $h$ -ARYLABELCOVER,  $N$  is the size of the instance, and  $f$  can be any function.*

Such a statement can be made in terms of the  $(\delta, h)$ -ARYGAPLABELCOVER problem, since it can be shown to be equivalent to  $\delta$ -Gap-Label-Cover( $t, R$ ) (see Appendix 3.5.3 for more details).

Furthermore, in the previous reduction, the constructed instance  $(\Gamma, k, \mathcal{F})$  sizes satisfy  $|\Gamma| = n|E|$  (with  $n$  a constant independent of the size of the instance),  $k = |V|$ , and  $|\mathcal{F}| = k \cdot L$ . Therefore, plugin Theorem 3.13 in the previous reduction leads to the following hardness result:



**Theorem 3.14.** *Assuming Gap-ETH and  $\varphi(n) = o(n)$ , we cannot achieve an  $(\alpha_\varphi + \varepsilon)$ -approximation for the  $\varphi$ -MAXCOVERAGE problem, even in  $f(k) \cdot m^{o(k)}$ -time, for any function  $f$ , with  $m$  the number of cover sets and  $k$  the cardinality constraint.*

### 3.3 Applications

In this section, we show how particular instances of  $\varphi$ -MAXCOVERAGE encapsulate and generalize various problems across the fields of information theory [CT01], computational social choice [BCE<sup>+</sup>16] and algorithmic game theory [NRTV07].

#### 3.3.1 Generalized List-Decoding

In the usual  $\ell$ -list-decoding problem [Eli57, Woz58], we are given a noisy channel  $W(y|x)$ , and the goal is to send a message chosen uniformly in  $[k]$  through this channel. In order to do so, the sender encodes the input message in  $\mathcal{X}$ , and the receiver decodes a list of size  $\ell$  of possible messages in  $[k]$  from the output of the channel in  $\mathcal{Y}$ . The goal is to maximize the probability of successfully decoding the message, which happens when the initial message belongs to the decoded list. We consider the generalization of the  $\ell$ -list-decoding problem that allows decoding lists of any size, with an associated cost function  $\varphi$ , which we call the  $\varphi$ -list-decoding problem. Now, the decoding will be successful only with probability  $\frac{\varphi(\ell)}{\ell}$  when the initial message belongs to a decoding list of size  $\ell$ . Formally, the problem can be stated as:

$$\max_{\{L_y\}_{y \in \mathcal{Y}}, S \subseteq \mathcal{X}: |S|=k} \frac{1}{k} \sum_{x \in S} \sum_{y \in \mathcal{Y}: x \in L_y} \frac{\varphi(|L_y|)}{|L_y|} W(y|x),$$

and can be directly reformulated as:

$$\max_{S \subseteq \mathcal{X}: |S|=k} \frac{1}{k} \sum_{y \in \mathcal{Y}} \max_{L_y \subseteq \mathcal{X}} \frac{\varphi(|L_y|)}{|L_y|} \sum_{x \in L_y} \mathbb{1}_{x \in S} W(y|x).$$

Let us show that with a coverage function  $\varphi(j) = \min(j, \ell)$ , we recover the  $\ell$ -list-decoding problem. Indeed, let us consider an optimal solution  $S \subseteq \mathcal{X}$ ,  $\{L_y\}_{y \in \mathcal{Y}}$  of the  $\varphi$ -list-decoding, with  $L_y$  the list of accepted messages when the output of the channel is  $y$ . If all lists  $L_y$  are of size  $\ell$ , then as  $\frac{\varphi(\ell)}{\ell} = 1$ , we recover a solution of the  $\ell$ -list-decoding problem with the same objective value. This shows in particular that the  $\varphi$ -list-decoding problem has an objective optimal value at least as large as the usual  $\ell$ -list-decoding problem. Let us now consider an arbitrary set  $\{L_y\}_{y \in \mathcal{Y}}$ , and let us look at a particular list  $L_y$  with  $L_y \neq \ell$ . Let us show that we can efficiently build another list of size  $\ell$  while keeping a solution with an objective value at least as good as with  $L_y$ . If  $|L_y| \leq \ell$ , then  $\frac{\varphi(|L_y|)}{|L_y|} = 1$ . Therefore, adding elements in  $L_y$  can only increase the objective value, as long as we keep  $\frac{\varphi(|L_y|)}{|L_y|} = 1$ , i.e. that the list size is smaller than or equal to  $\ell$ . Thus, we can transform all the lists  $L_y$  with  $|L_y| < \ell$  into lists of size  $\ell$  without decreasing the value of that solution. If  $|L_y| > \ell$ , then  $\frac{\varphi(|L_y|)}{|L_y|} = \frac{\ell}{|L_y|}$ . We will keep only the  $\ell$  most influencing messages in  $L_y$  and we will show that it does not decrease the objective value. Specifically, let us sort the elements  $x \in L_y$  in a nonincreasing order according to  $\mathbb{1}_{x \in S} W(y|x)$  and keep the first  $\ell$  elements of that list. We call  $L'_y$  the resulting list. We claim that replacing  $L_y$  by  $L'_y$  will not decrease the

objective value. Indeed, we have:

$$\sum_{x \in L'_y} \mathbb{1}_{x \in S} W(y|x) \geq \frac{\ell}{|L_y|} \sum_{x \in L_y} \mathbb{1}_{x \in S} W(y|x),$$

as  $L'_y$  contains the  $\ell$  largest elements of  $L_y$  according to the weight  $\mathbb{1}_{x \in S} W(y|x)$ . Therefore, since  $\frac{\varphi(|L'_y|)}{|L'_y|} = 1$ , we have:

$$\frac{\varphi(|L'_y|)}{|L'_y|} \sum_{x \in L'_y} \mathbb{1}_{x \in S} W(y|x) \geq \frac{\varphi(|L_y|)}{|L_y|} \sum_{x \in L_y} \mathbb{1}_{x \in S} W(y|x),$$

thus replacing  $L_y$  by  $L'_y$  does not decrease the objective value. This concludes the equivalence of the  $\ell$ -list-decoding problem with the  $\varphi$ -list-decoding with  $\varphi(j) = \min(j, \ell)$ .

When the channel is of the form  $W(y|x) = \frac{1}{t}$  for  $y \in T_x$  with  $|T_x| = t$  and  $W(y|x) = 0$  elsewhere, the success probability of the  $\varphi$ -list-decoding problem for a code  $S \subseteq \mathcal{X}$  can be written as  $\frac{1}{kt} \sum_{y \in \mathcal{Y}} \varphi(|S_y|)$ , with  $S_y := \{x \in S : y \in T_x\}$ , which is a particular instance of the  $\varphi$ -MAXCOVERAGE problem. Indeed, for a fixed code  $S$ , the objective value becomes:

$$\begin{aligned} \frac{1}{k} \sum_{y \in \mathcal{Y}} \max_{L_y \subseteq \mathcal{X}} \frac{\varphi(|L_y|)}{|L_y|} \sum_{x \in L_y} \mathbb{1}_{x \in S} W(y|x) &= \frac{1}{kt} \sum_{y \in \mathcal{Y}} \max_{L_y \subseteq \mathcal{X}} \frac{\varphi(|L_y|)}{|L_y|} \sum_{x \in L_y} \mathbb{1}_{x \in S} \mathbb{1}_{y \in T_x} \\ &= \frac{1}{kt} \sum_{y \in \mathcal{Y}} \max_{L_y \subseteq \mathcal{X}} \frac{\varphi(|L_y|)}{|L_y|} |S_y \cap L_y|. \end{aligned} \quad (3.8)$$

We will show that  $\max_{L_y \subseteq \mathcal{X}} \frac{\varphi(|L_y|)}{|L_y|} |S_y \cap L_y| = \varphi(|S_y|)$ , which will prove the claimed rewriting of the  $\varphi$ -list-decoding for those particular channels. As  $\varphi(0) = 0$  and  $\varphi$  is concave, we have for all  $y \geq x \geq 0$ :

$$\frac{\varphi(y) - \varphi(0)}{y - 0} \leq \frac{\varphi(x) - \varphi(0)}{x - 0},$$

i.e.  $\frac{x}{y} \varphi(y) \leq \varphi(x)$ . Therefore, we have that:

$$\frac{\varphi(|L_y|)}{|L_y|} |S_y \cap L_y| \leq \varphi(|S_y \cap L_y|) \leq \varphi(|S_y|),$$

as  $\varphi$  is nondecreasing. Thus,  $\max_{L_y \subseteq \mathcal{X}} \frac{\varphi(|L_y|)}{|L_y|} |S_y \cap L_y| \leq \varphi(|S_y|)$ , with the equality obtained by choosing  $L_y := S_y$ .

Therefore, for that class of channels, a tight approximation ratio  $\alpha_\varphi$  follows from Theorem 3.1. As a consequence, the hardness part holds for the general  $\varphi$ -list-decoding problem, whereas finding an approximation algorithm achieving the ratio  $\alpha_\varphi$  for all channels is left as an open question.

### 3.3.2 Multiwinner Elections

As mentioned previously, multiwinner elections (with a utilitarian model for the voters) entail selection of  $k$  (out of  $m$ ) candidates that maximize the utility across  $n$  voters. Here,

the utility of each voter  $a \in [n]$  increases with the number of approved (by  $a$ ) selections. The work of Dudycz et al. [DMMS20] study the computational complexity of such elections and, in particular, address classic voting rules in which—for a specified sequence of nonnegative weights  $(w_1, w_2, \dots)$ —voter  $a$ 's utility is equal to  $\sum_{i=1}^j w_i$ , when he approves of  $j$  candidates among the selected ones. One can view this election exercise as a coverage problem by considering subset  $T_i \subseteq [n]$  as the set of voters that approve of candidate  $i \in [m]$  and  $\varphi(j) = \sum_{i=1}^j w_i$ . Indeed, for a subset of candidates  $S \subseteq [m]$ , the utility of a voter  $a \in [n]$  is equal to  $\varphi(|S|_a)$ , with  $|S|_a = |\{i \in S : a \in T_i\}|$ .

Dudycz et al. [DMMS20] show that if the weights satisfy  $w_1 \geq w_2 \geq \dots$  (i.e., bear a diminishing returns property) along with geometric dominance ( $w_i \cdot w_{i+2} \geq w_{i+1}^2$  for all  $i \in \mathbb{N}^*$ ) and  $\lim_{i \rightarrow \infty} w_i = 0$ , then a tight approximation guarantee can be obtained for the election problem at hand. Note that the diminishing returns property implies that  $\varphi(j) = \sum_{i=1}^j w_i$  is concave and  $\lim_{i \rightarrow \infty} w_i = 0$  ensures that  $\varphi$  is sublinear (see Proposition 3.27). Hence, Theorem 3.1, together with Proposition 3.28, can be invoked to recover the result in [DMMS20] where we get  $\alpha_\varphi = \alpha_\varphi(1)$ . In fact, Theorem 3.1 does not require geometric dominance among the weights and, hence, applies to a broader class of voting rules. For instance, the geometric dominance property does not hold if one considers the voting weights induced by  $\ell$ -MULTICOVERAGE, i.e.,  $w_i = 1$ , for  $1 \leq i \leq \ell$ , and  $w_j = 0$  for  $j > \ell$ . However, using Theorem 3.1, we get that for this voting rule we can approximate the optimal utility within a factor of  $\alpha_\varphi = 1 - \frac{\ell^\ell e^{-\ell}}{\ell!}$  (see Proposition 3.31). Another example of such a separation arises if one truncates the proportional approval voting. The standard proportional approval voting corresponds to  $w_i = \frac{1}{i}$ , for all  $i \in \mathbb{N}$  (equivalently,  $\varphi(j) = \sum_{i=1}^j \frac{1}{i}$ ) and falls within the purview of [DMMS20]. While the truncated version with  $\varphi(j) = \sum_{i=1}^{\min(j, \ell)} \frac{1}{i}$ , for a given threshold  $\ell$ , does not satisfy geometric dominance, Theorem 3.1 continues to hold and provide a tight approximation ratio that can be computed numerically (see Proposition 3.21 and Table 3.1 for examples).

### 3.3.3 Resource Allocation in Multi-Agent Systems

A significant body of prior work in algorithmic game theory has addressed game-theoretic aspects of maximizing welfare among multiple (strategic) agents; see, e.g., [PM18]. Complementing such results, this section shows that the optimization problem underlying multiple welfare-maximization games can be expressed in terms of  $\varphi$ -MAXCOVERAGE.

Specifically, consider a setting with  $n$  resources,  $k$  agents, and a function  $\varphi : \mathbb{N} \mapsto \mathbb{R}_+$ . Every agent  $i$  is endowed with a collection of resource subsets  $\mathcal{A}_i = \{T_1^i, \dots, T_{m_i}^i\} \subseteq 2^{[n]}$  (i.e., each  $T_j^i \subseteq [n]$ ). The objective is to select a subset  $A_i \in \mathcal{A}_i$ , for all  $i \in [k]$ , so as to maximize  $W^\varphi(A_1, A_2, \dots, A_k) := \sum_{a \in [n]} w_a \varphi(|A|_a)$ . Here,  $w_a \in \mathbb{R}_+$  is a weight associated with  $a \in [n]$  and  $|A|_a := |\{i \in [k] : a \in A_i\}|$ . We will refer to this problem as the  $\varphi$ -RESOURCE ALLOCATION problem.

While  $\varphi$ -RESOURCE ALLOCATION does not directly reduce to  $\varphi$ -MAXCOVERAGE, the next theorem shows that it corresponds to maximizing  $\varphi$ -coverage functions subject to a matroid constraint. Hence, invoking our result from Section 3.1.1, we obtain a tight  $\alpha_\varphi$ -approximation for  $\varphi$ -RESOURCE ALLOCATION (see Appendix 3.5.5 for the proof):

**Theorem 3.15.** *For any normalized nondecreasing concave function  $\varphi$ , there exists a  $\alpha_\varphi$ -approximation algorithm for  $\varphi$ -RESOURCE ALLOCATION running in polynomial time. Further-*

more, for  $\varphi(n) = o(n)$ , it is NP-hard to approximate  $\varphi$ -RESOURCE ALLOCATION within a factor better than  $\alpha_\varphi + \varepsilon$ , for any constant  $\varepsilon > 0$ .

### 3.3.4 Vehicle-Target Assignment

VEHICLE-TARGET ASSIGNMENT [Mur00, PM18] is another problem which highlights the applicability of coverage problems, with a concave  $\varphi$ . In particular, VEHICLE-TARGET ASSIGNMENT can be directly expressed as  $\varphi$ -RESOURCE ALLOCATION: the  $[n]$  resources correspond to targets, the agents correspond to vehicles  $i \in [k]$ , each with a collection of covering choices  $\mathcal{A}_i \subseteq 2^{[n]}$ , and  $\varphi^p(j) = \frac{1-(1-p)^j}{p}$ , for a given parameter  $p \in (0, 1)$ . As limit cases, we define  $\varphi^0(j) := \lim_{p \rightarrow 0} \varphi^p(j) = j$  and  $\varphi^1(j) := 1$ . Since  $\varphi^p(j)$  is concave, by Proposition 3.32 and Theorem 3.15, we obtain a novel tight approximation ratio of  $\alpha_{\varphi^p} = \frac{1-e^{-p}}{p}$  for this problem. Also, one can look at the capped version of this problem,  $\varphi_\ell^p(j) := \varphi^p(\min(j, \ell))$ . In particular, we recover the  $\ell$ -MULTICOVERAGE function when  $p = 0$ . In Figure 3.1, we have plotted several cases of the tight approximations  $\alpha_{\varphi_\ell^p}$  in function of  $\ell$  for several values of  $\ell$ :

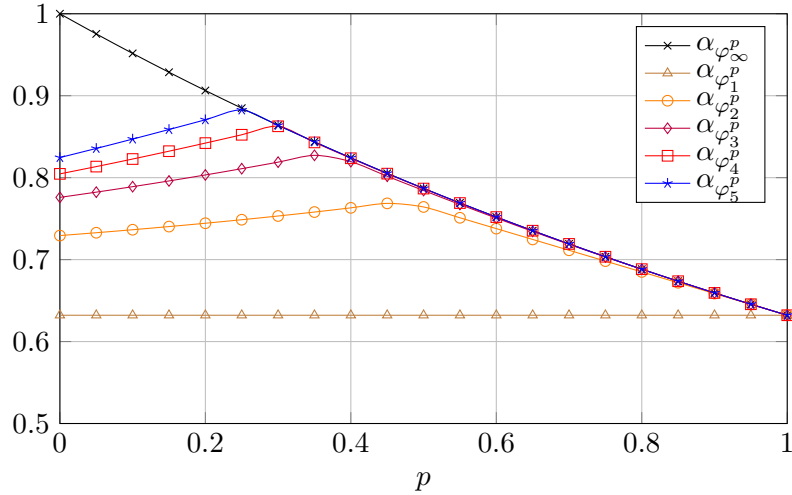

Figure 3.1 – Tight approximation ratios  $\alpha_{\varphi_\ell^p}$ , where  $\ell$  is the rank of the capped version of the  $p$ -VEHICLE-TARGET ASSIGNMENT problem. When  $p = 0$ , we recover the  $\ell$ -coverage problem.

Paccagnan and Marden [PM18] study the game-theoretic aspects of VEHICLE-TARGET ASSIGNMENT. A key goal in [PM18] is to bound the welfare loss incurred due to strategic selection by the  $k$  vehicles, i.e., the selection of each  $A_i \in \mathcal{A}_i$  by a self-interested vehicle/agent  $i \in [k]$ . The loss is quantified in terms of the *Price of Anarchy* (PoA). Formally, this performance metric is defined as ratio between the welfare of the worst-possible equilibria and the optimal welfare. Paccagnan and Marden [PM18] show that, for computationally tractable equilibrium concepts (in particular, for coarse correlated equilibria), tight price of anarchy bounds can be obtained via linear programs.

Note that our hardness result (Theorem 3.1) provides upper bounds on PoA of tractable equilibrium concepts—this follows from the observation that computing an equilibrium provides a specific method for finding a coverage solution. In [CPM19] and in the partic-

ular case of the  $\ell$ -MULTICOVERAGE problem, it is shown that this in fact an equality, i.e.,  $\text{PoA} = \alpha_\varphi$  if  $\varphi(j) = \min(j, \ell)$  for all values of  $\ell$ . However, numerically comparing the approximation ratio for VEHICLE-TARGET ASSIGNMENT,  $\alpha_{\varphi^p} = \frac{1-e^{-p}}{p}$ , with the optimal PoA bound, we note that  $\alpha_{\varphi^p}$  can in fact be strictly greater than the PoA guarantee; see Figure 3.2.

Another form of the current problem, considered in [PM18], corresponds to  $\varphi^d(j) = j^d$ , for a given parameter  $d \in (0, 1)$ . We refer to this instantiation as the  $d$ -POWER function and for it obtain the approximation ratio  $\alpha_{\varphi^d} = e^{-1} \sum_{k=1}^{+\infty} \frac{k^d}{k!}$  (Proposition 3.33). In this case, the question whether the inequality  $\text{PoA} \leq \alpha_{\varphi^d}$  is tight remains open; see Figure 3.3.

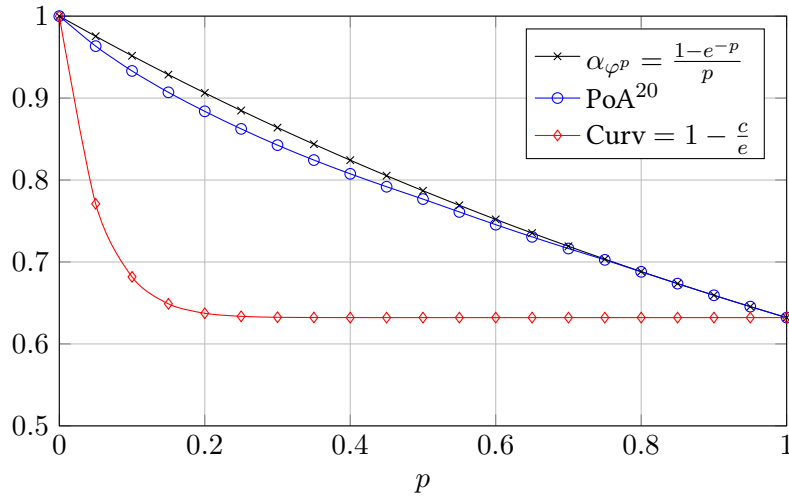

Figure 3.2 – Comparison between the PoA and  $\alpha_\varphi$  for the VEHICLE-TARGET ASSIGNMENT problem. Using the linear program found in [PM18], we were able to compute the blue curve  $\text{PoA}^{20}$ , the *Price of Anarchy* of this problem for  $m = 20$  players. Since the PoA only decreases when the number of players grows, this means that  $\text{PoA} < \alpha_\varphi$  in that case. As a comparison, the red curve *Curv* depicts the general approximation ratio (see [SVW17]) obtained for submodular function with curvature  $c$ , with  $c = 1 - \varphi^p(m) + \varphi^p(m-1)$  here.

### 3.3.5 Welfare Maximization for $\varphi$ -Coverage

Maximizing (social) welfare by partitioning items among agents is a key problem in algorithmic game theory; see, e.g., the extensive work on combinatorial auctions [NRTV07]. The goal here is to partition  $t$  items among a set of  $k$  agents such that the sum of values achieved by the agents—referred to as the social welfare—is maximized. That is, one needs to partition  $[t]$  into  $k$  pairwise disjoint subsets  $A_1, A_2, \dots, A_k$  with the objective of maximizing  $\sum_{i=1}^k v_i(A_i)$ . Here,  $v_i(S)$  denotes the valuation that agent  $i$  has for a subset of items  $S \subseteq [t]$ .

When each agent’s valuation  $v_i$  is submodular, a tight  $(1 - e^{-1})$ -approximation ratio is known for social welfare maximization [Von07]. This section shows that improved approximation guarantees can be achieved if, in particular, the agents’ valuations are  $\varphi$ -coverage functions. Towards a stylized application of such valuations, consider a setting in which each “item”  $b \in [t]$  represents a bundle (subset) of goods  $T_b \subseteq [n]$  and the value of

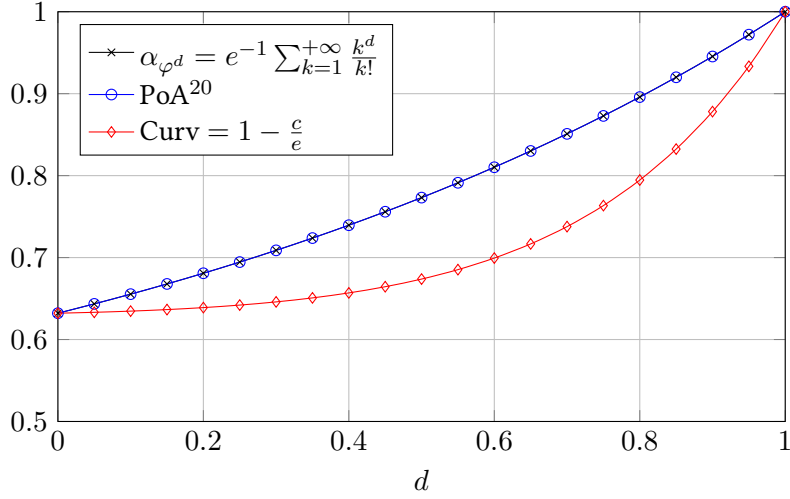

Figure 3.3 – Comparison between the PoA and  $\alpha_\varphi$  for the  $d$ -POWER problem. Using the linear program found in [PM18], we were able to compute the blue curve  $\text{PoA}^{20}$ , the *Price of Anarchy* of this problem for  $m = 20$  players. Here, the question whether the inequality  $\text{PoA} \leq \alpha_\varphi$  is tight remains open. As a comparison, the red curve *Curv* depicts the general approximation ratio (see [SVW17]) obtained for submodular function with curvature  $c$ , with  $c = 1 - \varphi^d(m) + \varphi^d(m - 1)$  here.

an agent increases with the number of copies of any good  $a \in [n]$  that get accumulated. Indeed, if each agent’s value for  $j$  copies of a good is  $\varphi(j)$ , then we have a  $\varphi$ -coverage function and the overall optimization problem is find a  $k$ -partition,  $A_1, A_2, \dots, A_k$ , of  $[t]$  that maximizes  $\sum_{i=1}^k \left( \sum_{a \in [n]} \varphi(|A_i|_a) \right)$ , where  $|A_i|_a := \{b \in A_i : a \in T_b\}$ .

In the current setup, one can obtain an  $\alpha_\varphi$  approximation ratio for social-welfare maximization by reducing this problem to  $\varphi$ -coverage with a matroid constraint, and applying the result from Section 3.1.1. Specifically, we can consider a partition matroid over the universe  $[t] \times [k]$ : for a bundle/item  $b \in [t]$  and an agent  $i \in [k]$ , the element  $(b, i)$  in the universe represents that bundle  $b$  is assigned to agent  $i$ , i.e.,  $b \in A_i$ . The partition-matroid constraint is imposed to ensure that each bundle  $b$  is assigned to at most one agent. Furthermore, we can create  $k$  copies of the underlying set of goods  $[n]$  and set  $T_{(b,i)} := \{(a, i) : a \in T_b\}$  to map the  $\varphi$ -coverage over the universe to the social-welfare objective. This, overall, gives us the desired  $\alpha_\varphi$  approximation guarantee.

### 3.4 Conclusion

We have introduced the  $\varphi$ -MAXCOVERAGE problem where having  $c$  copies of element  $a$  gives a value  $\varphi(c)$ . We have shown that when  $\varphi$  is normalized, nondecreasing and concave, we can obtain an approximation guarantee given by the *Poisson concavity ratio*  $\alpha_\varphi := \min_{x \in \mathbb{N}^*} \frac{\mathbb{E}[\varphi(\text{Poi}(x))]}{\varphi(\mathbb{E}[\text{Poi}(x)])}$  and we showed it is tight for sublinear functions  $\varphi$ . The Poisson concavity ratio strictly beats the bound one gets using the notion of curvature of submodular functions, except in limit cases such as MAXCOVERAGE where the bounds are equal.

An interesting open question is whether there exists combinatorial algorithms that achieve

this approximation ratio. As mentioned in [BFGG20], for the  $\ell$ -MULTICOVERAGE with  $\ell \geq 2$ , which is the special case where  $\varphi(x) = \min(x, \ell)$ , the simple greedy algorithm only gives a  $1 - e^{-1}$  approximation ratio, which is strictly less than the ratio  $\alpha_\varphi = 1 - \frac{\ell^\ell e^{-\ell}}{\ell!}$  in that case. Also, for any geometrically dominant vector  $w = (\varphi(i+1) - \varphi(i))_{i \in \mathbb{N}}$  which is not  $p$ -geometric, such as PROPORTIONAL APPROVAL VOTING, the greedy algorithm achieves an approximation ratio which is strictly less than  $\alpha_\varphi$  (see Theorem 18 of [DMMS20]).

Another open question is whether the hardness result remains true when  $\varphi(n) \neq o(n)$ . A good example is given by  $\varphi(0) = 0$  and  $\varphi(1+t) = 1 + (1-c)t$  with  $c \in (0, 1)$ . We know that the problem is hard for  $c = 1$  but easy for  $c = 0$ . One can show that the approximation ratio achieved by our algorithm is  $\alpha_\varphi = 1 - \frac{c}{e}$  in that case (which is the same approximation ratio obtained from the curvature in [SVW17]), but the tightness of this approximation ratio remains open.

## 3.5 Appendix

### 3.5.1 General Properties

In this section, we will assume that  $\varphi$  is specified over nonnegative integers (i.e.  $\varphi : \mathbb{N} \rightarrow \mathbb{R}_+$ ) and that it is nondecreasing, concave, and normalized (i.e.  $\varphi(0) = 0$  and  $\varphi(1) = 1$ ). We will consider its piecewise linear extension on  $\mathbb{R}_+$  by defining  $\varphi(x) := \lambda\varphi(\lfloor x \rfloor) + (1 - \lambda)\varphi(\lceil x \rceil)$ ; here, parameter  $\lambda \in [0, 1]$  satisfies  $x = \lambda\lfloor x \rfloor + (1 - \lambda)\lceil x \rceil$ . Note that the piecewise linear extension is also nondecreasing and concave.

**Proposition 3.16.** *For all  $x \in \mathbb{R}_+$ , we have  $\alpha_\varphi(x) \geq \min(\alpha_\varphi(\lfloor x \rfloor), \alpha_\varphi(\lceil x \rceil))$ ; here,  $\alpha_\varphi(0) := \lim_{x \rightarrow 0} \alpha_\varphi(x) = 1$ .*

*Proof.* For any  $x \geq 1$ , consider parameter  $\lambda \in [0, 1]$  such that  $x = \lambda\lfloor x \rfloor + (1 - \lambda)\lceil x \rceil$ . Since  $x \mapsto \mathbb{E}[\varphi(\text{Poi}(x))]$  is concave (Proposition 3.25), the following bound holds for all  $x \geq 1$ :

$$\begin{aligned} \mathbb{E}[\varphi(\text{Poi}(x))] &\geq \lambda \mathbb{E}[\varphi(\text{Poi}(\lfloor x \rfloor))] + (1 - \lambda) \mathbb{E}[\varphi(\text{Poi}(\lceil x \rceil))] \\ &= \lambda \alpha_\varphi(\lfloor x \rfloor) \varphi(\lfloor x \rfloor) + (1 - \lambda) \alpha_\varphi(\lceil x \rceil) \varphi(\lceil x \rceil) \quad \text{by definition of } \alpha_\varphi(x) \\ &\geq \min(\alpha_\varphi(\lfloor x \rfloor), \alpha_\varphi(\lceil x \rceil)) (\lambda \varphi(\lfloor x \rfloor) + (1 - \lambda) \varphi(\lceil x \rceil)) \\ &= \min(\alpha_\varphi(\lfloor x \rfloor), \alpha_\varphi(\lceil x \rceil)) \varphi(x), \end{aligned} \tag{3.9}$$

since  $\varphi$  linear between integers. Therefore,  $\alpha_\varphi(x) = \frac{\mathbb{E}[\varphi(\text{Poi}(x))]}{\varphi(x)} \geq \min(\alpha_\varphi(\lfloor x \rfloor), \alpha_\varphi(\lceil x \rceil))$ .

We will show next that  $\alpha_\varphi(x)$  is nonincreasing from 0 to 1, which implies that for  $x \in [0, 1]$ , we have  $\alpha_\varphi(x) \geq \min(\alpha_\varphi(\lfloor x \rfloor), \alpha_\varphi(\lceil x \rceil))$ . Since  $\varphi$  is linear between integers,  $\varphi(0) = 0$  and  $\varphi(1) = 1$ , we have that  $\varphi(x) = x$  for all  $x \in [0, 1]$ . Therefore:

$$\alpha_\varphi(x) = \frac{\mathbb{E}[\varphi(\text{Poi}(x))]}{x} = e^{-x} \sum_{k=1}^{+\infty} \frac{\varphi(k)}{k} \frac{x^{k-1}}{(k-1)!} = e^{-x} \sum_{k=0}^{+\infty} \frac{\varphi(k+1)}{k+1} \frac{x^k}{k!}.$$

In particular,  $\alpha_\varphi(x)$  is well-defined at 0 and  $\alpha_\varphi(0) = e^{-0} \sum_{k=0}^{+\infty} \frac{\varphi(k+1)}{k+1} \frac{0^k}{k!} = 1$ . Now, consider the derivative:

$$\begin{aligned} \alpha'_\varphi(x) &= e^{-x} \left( - \sum_{k=0}^{+\infty} \frac{\varphi(k+1)}{k+1} \frac{x^k}{k!} + \sum_{k=1}^{+\infty} \frac{\varphi(k+1)}{k+1} \frac{x^{k-1}}{(k-1)!} \right) \\ &= e^{-x} \sum_{k=0}^{+\infty} \left( \frac{\varphi(k+2)}{k+2} - \frac{\varphi(k+1)}{k+1} \right) \frac{x^k}{k!}. \end{aligned} \tag{3.10}$$

Note that  $\frac{\varphi(k+2)}{k+2} - \frac{\varphi(k+1)}{k+1} = \frac{\varphi(k+2) - \varphi(0)}{(k+2) - 0} - \frac{\varphi(k+1) - \varphi(0)}{(k+1) - 0} \leq 0$ ; the last inequality follows from the concavity of  $\varphi$ . Hence,  $\alpha'_\varphi(x) \leq 0$ . That is,  $\alpha_\varphi(x)$  is nonincreasing from 0 to 1.  $\square$

**Proposition 3.17.** *For any  $\varepsilon > 0$ , the bound  $1 - \alpha_\varphi(x) \leq \varepsilon$  holds for all  $x \geq \left(\frac{6}{\varepsilon}\right)^4$ .*

*Proof.* Write  $X \sim \text{Poi}(x)$  and note that  $\mathbb{P}(X \leq x(1 - \delta(x))) \leq \exp\left(-\frac{x\delta(x)^2}{2(1+\delta(x))}\right)$ , for any positive function  $\delta(\cdot)$  which satisfies  $\delta(x) < 1$ , for all  $x > 1$ ; see for instance [Can17].



Therefore:

$$\begin{aligned}
\mathbb{E}[\varphi(X)] &\geq e^{-x} \sum_{k=\lceil x(1-\delta(x)) \rceil}^{+\infty} \varphi(k) \frac{x^k}{k!} \quad \text{since } \varphi \text{ nonnegative} \\
&\geq \varphi(x(1-\delta(x))) \sum_{k=\lceil x(1-\delta(x)) \rceil}^{+\infty} e^{-x} \frac{x^k}{k!} \quad \text{since } \varphi \text{ nondecreasing} \\
&\geq \varphi(x(1-\delta(x)))(1 - \mathbb{P}(X \leq x(1-\delta(x)))) \\
&\geq \varphi(x(1-\delta(x))) \left( 1 - \exp\left(-\frac{x\delta(x)^2}{2(1+\delta(x))}\right) \right).
\end{aligned} \tag{3.11}$$

Next, we will show that  $\frac{\varphi(x(1-\delta(x)))}{\varphi(x)} \geq 1 - \frac{\delta(x) + \frac{1}{x}}{1-\delta(x)}$ . Towards this end, we will first bound  $\varphi(x+y) - \varphi(x)$  in terms of  $w_k^x = \varphi(x+k) - \varphi(x+k-1)$ , which constitutes a nonincreasing sequence (since  $\varphi$  is concave):

$$\varphi(x+y) - \varphi(x) \leq \varphi(x + \lfloor y \rfloor + 1) - \varphi(x + \lfloor y \rfloor) + \sum_{k=1}^{\lfloor y \rfloor} w_k^x \leq (\lfloor y \rfloor + 1)w_1^x.$$

Applying this bound to  $x(1-\delta(x))$  and  $x\delta(x)$  gives us:

$$\begin{aligned}
1 - \frac{\varphi(x(1-\delta(x)))}{\varphi(x)} &= \frac{\varphi(x) - \varphi(x(1-\delta(x)))}{\varphi(x)} \leq \frac{(\lfloor x\delta(x) \rfloor + 1)w_1^{x(1-\delta(x))}}{\varphi(x)} \\
&\leq \frac{x\delta(x) + 1}{\varphi(x)} \frac{\varphi(x(1-\delta(x)))}{x(1-\delta(x))} \leq \frac{x\delta(x) + 1}{x(1-\delta(x))} = \frac{\delta(x) + \frac{1}{x}}{1-\delta(x)}.
\end{aligned} \tag{3.12}$$

Here,  $w_1^{x(1-\delta(x))} = \frac{\varphi(x(1-\delta(x))+1) - \varphi(x(1-\delta(x)))}{(x(1-\delta(x))+1) - x(1-\delta(x))} \leq \frac{\varphi(x(1-\delta(x))) - \varphi(0)}{x(1-\delta(x)) - 0} = \frac{\varphi(x(1-\delta(x)))}{x(1-\delta(x))}$  follows from the concavity of  $\varphi$  and  $\frac{\varphi(x(1-\delta(x)))}{\varphi(x)} \leq 1$  from the fact that  $\varphi$  is nondecreasing.

Inequalities (3.11) and (3.12) lead to following upper bound on  $1 - \alpha_\varphi(x)$  in terms of  $\delta(x)$ :

$$\begin{aligned}
1 - \alpha_\varphi(x) &= 1 - \frac{\mathbb{E}[\varphi(\text{Poi}(x))]}{\varphi(x)} \leq 1 - \left( 1 - \frac{\delta(x) + \frac{1}{x}}{1-\delta(x)} \right) \left( 1 - \exp\left(-\frac{x\delta(x)^2}{2(1+\delta(x))}\right) \right) \\
&\leq \frac{\delta(x) + \frac{1}{x}}{1-\delta(x)} + \exp\left(-\frac{x\delta(x)^2}{2(1+\delta(x))}\right).
\end{aligned} \tag{3.13}$$

Specifically setting  $\delta(x) = x^{-\frac{1}{4}}$ , we have (for all  $x \geq 16$ ):  $\delta(x) \leq \frac{1}{2}$ ,  $\frac{1}{x} \leq x^{-\frac{1}{4}}$ , and  $\exp\left(-\frac{x\delta(x)^2}{2(1+\delta(x))}\right) \leq \exp\left(-\frac{\sqrt{x}}{4}\right) \leq 2x^{-\frac{1}{4}}$ . Hence, inequality (3.13) reduces to

$$1 - \alpha_\varphi(x) \leq \frac{2x^{-\frac{1}{4}}}{1 - \frac{1}{2}} + 2x^{-\frac{1}{4}} \leq 6x^{-\frac{1}{4}} \quad \text{for all } x \geq 16.$$

If  $\varepsilon \geq 1$ , we have  $1 - \alpha_\varphi(x) \leq 1 \leq \varepsilon$ . Otherwise, we have that  $\left(\frac{6}{\varepsilon}\right)^4 \geq 6^4 \geq 16$ . Therefore, given any  $\varepsilon > 0$ , for all  $x \geq \left(\frac{6}{\varepsilon}\right)^4$  we have  $1 - \alpha_\varphi(x) \leq \varepsilon$ .  $\square$

**Proposition 3.18.** *We have that  $\alpha_\varphi = \inf_{x \in \mathbb{R}_+} \alpha_\varphi(x) = \min_{x \in \mathbb{N}^*} \alpha_\varphi(x)$ .*

*Proof.* Thanks to Proposition 3.16, we have that  $\inf_{x \in \mathbb{R}_+} \alpha_\varphi(x) = \inf_{x \in \mathbb{N}^*} \alpha_\varphi(x)$ , and thanks to Proposition 3.17, since  $\alpha_\varphi(x) \leq 1$ , we have that  $\inf_{x \in \mathbb{N}^*} \alpha_\varphi(x) = \min_{x \in \mathbb{N}^*} \alpha_\varphi(x)$ .  $\square$

**Proposition 3.19.**  *$C^\varphi$  is submodular, its curvature is at most  $c = 1 - (\varphi(m) - \varphi(m-1))$  and it cannot be improved for a general instance with  $m$  cover sets.*

*Proof.* We will use the following straightforward lemma:

**Lemma 3.20** (Properties of  $|S|_a = |\{i \in S : a \in T_i\}|$ ). *We have:*

1.  $|S|_a \leq |S|$ ,
2.  $|S \cup S'|_a \leq |S|_a + |S'|_a$ . If  $S \subseteq T$  then  $|S|_a \leq |T|_a$  and  $|S \cup \{x\}|_a \leq |S|_a + 1$ ,
3. If  $S \subseteq T$ ,  $x \notin T$  then  $|S|_a = |T|_a \Rightarrow |S \cup \{x\}|_a = |T \cup \{x\}|_a$ .

Let us show first the submodularity of  $C^\varphi$ . Let  $S \subseteq T \subseteq [m]$  and  $x \notin T$ :

$$\begin{aligned} & C^\varphi(S \cup \{x\}) - C^\varphi(S) - (C^\varphi(T \cup \{x\}) - C^\varphi(T)) = \\ &= \sum_{a \in [n]} w_a [\varphi(|S \cup \{x\}|_a) - \varphi(|S|_a) - (\varphi(|T \cup \{x\}|_a) - \varphi(|T|_a))]. \end{aligned} \quad (3.14)$$

Let us call  $g(a) := \varphi(|S \cup \{x\}|_a) - \varphi(|S|_a) - (\varphi(|T \cup \{x\}|_a) - \varphi(|T|_a))$ :

1. If  $|T|_a = |S|_a$  then thanks to Lemma 3.20, we have that  $|T \cup \{x\}|_a = |S \cup \{x\}|_a$ , so  $g(a) = 0$
2. Else, we have that  $|T|_a > |S|_a$ :
  - a) If  $|S \cup \{x\}|_a = |S|_a$ , then we add elements of  $T - S$  using Lemma 3.20 to get that  $|T \cup \{x\}|_a = |T|_a$ , so  $g(a) = 0$  in that case.
  - b) Else  $|S \cup \{x\}|_a \neq |S|_a$ . So with  $|S|_a = k$ , we get that  $|S \cup \{x\}|_a = k + 1$  and  $|T|_a > |S|_a$  so  $|T|_a \geq k + 1$ .
    - i. If  $|T \cup \{x\}|_a = |T|_a$ , then  $g(a) = \varphi(k + 1) - \varphi(k) \geq 0$  since  $\varphi$  is nondecreasing.
    - ii. Else  $|T \cup \{x\}|_a \neq |T|_a$  so with  $|T|_a = \ell$  with  $\ell \geq k + 1$ , we get that  $|T|_a = \ell + 1$ . So we have that:

$$\begin{aligned} g(a) &= \varphi(k + 1) - \varphi(k) - (\varphi(\ell + 1) - \varphi(\ell)) \\ &= \frac{\varphi(k + 1) - \varphi(k)}{(k + 1) - k} - \frac{\varphi(\ell + 1) - \varphi(\ell)}{(\ell + 1) - \ell} \geq 0, \end{aligned} \quad (3.15)$$

by concavity of  $\varphi$ : its slopes are nonincreasing.

So in all cases, we have  $g(a) \geq 0$  so  $C^\varphi(S \cup \{x\}) - C^\varphi(S) - (C^\varphi(T \cup \{x\}) - C^\varphi(T)) \geq 0$ :  $C^\varphi$  is submodular.

Let us now compute its curvature:

$$c = 1 - \min_{i \in [m]} \frac{C^\varphi([m]) - C^\varphi([m] - \{i\})}{C^\varphi(\{i\}) - C^\varphi(\emptyset)}.$$

Let  $i \in [m]$  fixed:

$$\begin{aligned} \frac{C^\varphi([m]) - C^\varphi([m] - \{i\})}{C^\varphi(\{i\}) - C^\varphi(\emptyset)} &= \frac{\sum_{a \in [n]} w_a [\varphi(|[m]|_a) - \varphi(|[m] - \{i\}|_a)]}{\sum_{a \in [n]} w_a [\varphi(|\{i\}|_a) - \varphi(|\emptyset|_a)]} \\ &= \frac{\sum_{a \in T_i} w_a [\varphi(|[m]|_a) - \varphi(|[m] - \{i\}|_a)]}{\sum_{a \in T_i} w_a} \\ &= \frac{\sum_{a \in T_i} w_a [\varphi(|[m]|_a) - \varphi(|[m]|_a - 1)]}{\sum_{a \in T_i} w_a}, \end{aligned} \quad (3.16)$$

since  $a \in T_i$ . But  $|[m]|_a \leq m$  and  $\varphi$  concave, so  $\varphi(|[m]|_a) - \varphi(|[m]|_a - 1) \geq \varphi(m) - \varphi(m - 1)$  for all  $a \in [n]$ . As a consequence we have that:

$$\frac{C^\varphi([m]) - C^\varphi([m] - \{i\})}{C^\varphi(\{i\}) - C^\varphi(\emptyset)} \geq \varphi(m) - \varphi(m - 1),$$

and this lower bound is true for its minimum over  $i$ . Thus we get that  $c \leq 1 - (\varphi(m) - \varphi(m - 1))$ . Also one can find instances for all  $m$  such that this bound is tight: take  $T_1 = \{a\}$  and  $\forall j \in [m], a \in T_j$  for instance.  $\square$

**Proposition 3.21.** *Let  $\ell \in \mathbb{N}^*$ . if  $\forall x \geq \ell, \varphi(x) = \varphi(\ell) + a(x - \ell)$  for some  $0 \leq a \leq \varphi(\ell) - \varphi(\ell - 1)$ , then  $\alpha_\varphi(x)$  is nondecreasing from  $\ell$  to  $+\infty$  and:*

$$\alpha_\varphi(x) = \frac{\varphi(\ell) + a(x - \ell)}{\varphi(x)} - \frac{e^{-x}}{\varphi(x)} \left( \sum_{k=0}^{\ell} (\varphi(\ell) + a(x - \ell) - \varphi(k)) \frac{x^k}{k!} - a \frac{x^{\ell+1}}{\ell!} \right).$$

In particular,  $\alpha_\varphi = \min_{x \in [\ell]} \alpha_\varphi(x)$ , and the argmin can be computed numerically.

*Proof.* One can compute a closed form value for  $\alpha_\varphi(x)$  using the fact that  $\varphi$  is linear from  $\ell$ :

$$\begin{aligned} \alpha_\varphi(x) &= \frac{e^{-x}}{\varphi(x)} \sum_{k=0}^{+\infty} \varphi(k) \frac{x^k}{k!} = \frac{e^{-x}}{\varphi(x)} \left( \sum_{k=0}^{\ell} \varphi(k) \frac{x^k}{k!} + \sum_{k=\ell+1}^{+\infty} (\varphi(\ell) + a(k - \ell)) \frac{x^k}{k!} \right) \\ &= \frac{\varphi(\ell) - a\ell}{\varphi(x)} + \frac{e^{-x}}{\varphi(x)} \left( \sum_{k=0}^{\ell} (\varphi(k) - \varphi(\ell) + a\ell) \frac{x^k}{k!} + ax \sum_{k=\ell+1}^{+\infty} \frac{x^{k-1}}{(k-1)!} \right) \\ &= \frac{\varphi(\ell) + a(x - \ell)}{\varphi(x)} + \frac{e^{-x}}{\varphi(x)} \left( \sum_{k=0}^{\ell} (\varphi(k) - \varphi(\ell) + a(\ell - x)) \frac{x^k}{k!} + ax \frac{x^\ell}{\ell!} \right), \end{aligned} \quad (3.17)$$

and thus we get:

$$\alpha_\varphi(x) = \frac{\varphi(\ell) + a(x - \ell)}{\varphi(x)} - \frac{e^{-x}}{\varphi(x)} \left( \sum_{k=0}^{\ell} (\varphi(\ell) + a(x - \ell) - \varphi(k)) \frac{x^k}{k!} - a \frac{x^{\ell+1}}{\ell!} \right).$$

Let us show that it is nondecreasing from  $\ell$  to  $+\infty$  by computing its derivative. Indeed, for  $x \geq \ell$ , we have that  $\varphi(x) = \varphi(\ell) + a(x - \ell)$  and  $\varphi'(x) = a$ , so:

$$\alpha_\varphi(x) = 1 - e^{-x} \left( \sum_{k=0}^{\ell} \frac{x^k}{k!} - \frac{1}{\varphi(x)} \left( \sum_{k=0}^{\ell} \varphi(k) \frac{x^k}{k!} + a \frac{x^{\ell+1}}{\ell!} \right) \right).$$

Thus:

$$\begin{aligned} \alpha'_\varphi(x) &= e^{-x} \left( \sum_{k=0}^{\ell} \frac{x^k}{k!} - \frac{1}{\varphi(x)} \left( \sum_{k=0}^{\ell} \varphi(k) \frac{x^k}{k!} + a \frac{x^{\ell+1}}{\ell!} \right) \right) \\ &\quad - e^{-x} \left( \sum_{k=0}^{\ell-1} \frac{x^k}{k!} - \frac{1}{\varphi(x)} \left( \sum_{k=0}^{\ell-1} \varphi(k+1) \frac{x^k}{k!} + a(\ell+1) \frac{x^\ell}{\ell!} \right) \right) \\ &\quad + e^{-x} \frac{a}{\varphi(x)^2} \left( \sum_{k=0}^{\ell} \varphi(k) \frac{x^k}{k!} + a \frac{x^{\ell+1}}{\ell!} \right) \\ &= e^{-x} \left( \frac{x^\ell}{\ell!} - \frac{1}{\varphi(x)} \left( \sum_{k=0}^{\ell-1} (\varphi(k) - \varphi(k+1)) \frac{x^k}{k!} + \varphi(\ell) \frac{x^\ell}{\ell!} + (a(x - \ell) - a) \frac{x^\ell}{\ell!} \right) \right) \\ &\quad - e^{-x} \left( \frac{a}{\varphi(x)^2} \left( \sum_{k=0}^{\ell} \varphi(k) \frac{x^k}{k!} + a \frac{x^{\ell+1}}{\ell!} \right) \right) \\ &= e^{-x} \left( \frac{x^\ell}{\ell!} + \frac{1}{\varphi(x)} \left( \sum_{k=0}^{\ell-1} (\varphi(k+1) - \varphi(k)) \frac{x^k}{k!} \right) - \frac{\varphi(x) - a x^\ell}{\varphi(x) \ell!} \right) \\ &\quad - e^{-x} \frac{a}{\varphi(x)^2} \left( \sum_{k=0}^{\ell} \varphi(k) \frac{x^k}{k!} + a \frac{x^{\ell+1}}{\ell!} \right) \\ &= e^{-x} \left( \frac{1}{\varphi(x)} \left( \sum_{k=0}^{\ell-1} (\varphi(k+1) - \varphi(k)) \frac{x^k}{k!} \right) \right) \\ &\quad + e^{-x} \frac{a}{\varphi(x)^2} \left( \varphi(x) \frac{x^\ell}{\ell!} - \sum_{k=0}^{\ell} \varphi(k) \frac{x^k}{k!} - a \frac{x^{\ell+1}}{\ell!} \right). \end{aligned} \tag{3.18}$$

If  $a = 0$ , then it is nonnegative since  $\varphi$  nondecreasing and nonnegative. Otherwise, suppose that  $a > 0$ . Then:

$$\begin{aligned} \alpha_\varphi(x) &= \frac{ae^{-x}}{\varphi(x)^2} \left( \sum_{k=0}^{\ell-1} \left( \varphi(x) \frac{\varphi(k+1) - \varphi(k)}{a} - \varphi(k) \right) \frac{x^k}{k!} + (\varphi(x) - \varphi(\ell) - ax) \frac{x^\ell}{\ell!} \right) \\ &\geq \frac{ae^{-x}}{\varphi(x)^2} \left( \sum_{k=0}^{\ell-1} (\varphi(x) - \varphi(k)) \frac{x^k}{k!} - a \frac{x^\ell}{(\ell-1)!} \right), \end{aligned} \tag{3.19}$$

since  $\frac{\varphi(k+1) - \varphi(k)}{a} \geq \frac{\varphi(k+1) - \varphi(k)}{\varphi(\ell) - \varphi(\ell-1)} \geq 1$  by concavity of  $\varphi$ . Thus:

$$\alpha_\varphi(x) \geq \frac{ae^{-x}}{\varphi(x)^2} \left( \sum_{k=0}^{\ell-1} (\varphi(\ell) - \varphi(k)) \frac{x^k}{k!} + a \left( (x - \ell) \sum_{k=0}^{\ell-1} \frac{x^k}{k!} - \frac{x^\ell}{(\ell-1)!} \right) \right),$$

but:

$$(x - \ell) \sum_{k=0}^{\ell-1} \frac{x^k}{k!} - \frac{x^\ell}{(\ell-1)!} = \ell \sum_{k=1}^{\ell} \frac{x^k}{k!} - \ell \sum_{k=0}^{\ell-1} \frac{x^k}{k!} - \frac{x^\ell}{(\ell-1)!} = -\ell,$$

so:

$$\begin{aligned}
\alpha'_\varphi(x) &\geq \frac{ae^{-x}}{\varphi(x)^2} \left( \sum_{k=0}^{\ell-1} (\varphi(\ell) - \varphi(k)) \frac{x^k}{k!} - a\ell \right) \\
&\geq \frac{ae^{-x}}{\varphi(x)^2} \left( \sum_{k=0}^{\ell-1} (\varphi(\ell) - \varphi(k)) \frac{x^k}{k!} - (\varphi(\ell) - \varphi(\ell-1))\ell \right) \\
&\geq \frac{ae^{-x}}{\varphi(x)^2} \left( \sum_{k=0}^{\ell-1} (\varphi(\ell) - \varphi(k)) \frac{x^k}{k!} - \sum_{k=0}^{\ell-1} (\varphi(\ell) - \varphi(\ell-1)) \frac{x^k}{k!} \right) \quad (3.20) \\
&\quad \text{since } \frac{x^k}{k!} \geq \frac{\ell^k}{k!} \geq 1 \text{ for } k \leq \ell \\
&= \frac{ae^{-x}}{\varphi(x)^2} \left( \sum_{k=0}^{\ell-1} (\varphi(\ell-1) - \varphi(k)) \frac{x^k}{k!} \right) \geq 0 \quad \text{since } \varphi \text{ nondecreasing.}
\end{aligned}$$

Thus,  $\alpha_\varphi(x)$  is nondecreasing from  $\ell$  to  $+\infty$ , and we get that  $\alpha_\varphi = \min_{x \in [\ell]} \alpha_\varphi(x)$ .  $\square$

**Proposition 3.22.** *The Poisson concavity ratio  $\alpha_\varphi$  is always greater than or equal to the curvature-dependent ratio defined in [SVW17]: if  $\varphi$  is linear from  $m$  with slope  $1 - c = \varphi(m) - \varphi(m-1)$ , then we have  $\alpha_\varphi \geq 1 - ce^{-1}$ .*

*Proof.* Note that by Proposition 3.19, the curvature of  $C^\varphi$  is equal to  $c$ , so the efficiency of the algorithm described in [SVW17] is indeed  $1 - ce^{-1}$ . Thanks to Proposition 3.21, we have that  $\alpha_\varphi = \min_{x \in [\ell]} \alpha_\varphi(x)$ , so we only have to show that:

$$\min_{\ell \in [m]} \alpha_\varphi(\ell) \geq 1 - ce^{-1}.$$

Let us denote by  $\varphi^{(\ell,a)}$  the function which is equal to  $\varphi$  for  $k \leq \ell$  and linear from  $\ell$  with nonnegative coefficient  $a$ :  $\forall k \geq \ell, \varphi^{(\ell,a)}(k) = \varphi(\ell) + a(k - \ell)$ . Note that we ask that  $0 \leq a \leq \varphi(\ell) - \varphi(\ell-1)$  in order to  $\varphi^{(\ell,a)}$  to be nondecreasing concave, and  $\ell \geq 1$ .

This is done in two steps:

1. Let  $1 \leq \ell \leq m$ , then:

$$\alpha_\varphi(\ell) = \frac{\mathbb{E}[\varphi(\text{Poi}(\ell))]}{\varphi(\ell)} = \frac{\mathbb{E}[\varphi(\text{Poi}(\ell))]}{\varphi^{(\ell,1-c)}(\ell)} \geq \frac{\mathbb{E}[\varphi^{(\ell,1-c)}(\text{Poi}(\ell))]}{\varphi^{(\ell,1-c)}(\ell)} = \alpha_{\varphi^{(\ell,1-c)}}(\ell),$$

since  $\varphi^{(\ell,1-c)}(x) \leq \varphi(x)$  for all  $x$ . Note that we have:

$$\varphi(\ell) - \varphi(\ell-1) \geq \varphi(m) - \varphi(m-1) = 1 - c,$$

by concavity of  $\varphi$ . So, we only have to show that for all  $1 \leq \ell \leq m$ , we have  $\alpha^{(\ell,1-c)} := \alpha_{\varphi^{(\ell,1-c)}}(\ell) \geq 1 - ce^{-1}$ .

2. Let us show that  $\alpha^{(\ell,1-c)} := \alpha_{\varphi^{(\ell,1-c)}}(\ell) \geq 1 - ce^{-1}$  for  $1 \leq \ell \leq m$ .

Using the closed-form expression of Proposition 3.21 on  $\varphi^{(\ell, 1-c)}$  evaluated at  $\ell$ , one gets:

$$\alpha^{(\ell, 1-c)} = \alpha_{\varphi^{(\ell, 1-c)}}(\ell) = 1 - e^{-\ell} \left( \sum_{k=0}^{\ell-1} \left( \frac{\varphi(\ell) - \varphi(k)}{\varphi(\ell)} \right) \frac{\ell^k}{k!} - \frac{1-c}{\varphi(\ell)} \frac{\ell^{\ell+1}}{\ell!} \right).$$

The worst case occurs when  $\varphi^{(\ell, 1-c)}$  is linear between 1 and  $\ell$ , which we call  $\varphi_{\text{lin}}^{(\ell, 1-c)}$ . Indeed, with  $b := \frac{\varphi(\ell) - 1}{\ell - 1}$ , for  $1 \leq k \leq \ell$ , we have that  $\varphi_{\text{lin}}^{(\ell, 1-c)}(k) = 1 + b(k - 1)$ . But:

$$\sum_{k=0}^{\ell-1} \left( \frac{\varphi(\ell) - \varphi(k)}{\varphi(\ell)} \right) \frac{\ell^k}{k!} \leq 1 + \sum_{k=1}^{\ell-1} \left( \frac{\varphi(\ell) - (1 + b(k - 1))}{\varphi(\ell)} \right) \frac{\ell^k}{k!},$$

since  $\varphi(k) \geq 1 + b(k - 1)$ , because  $\frac{\varphi(k) - \varphi(1)}{k - 1} \geq \frac{\varphi(\ell) - \varphi(1)}{\ell - 1} = b$  by concavity of  $\varphi$ . In that case, the expression can be simplified:

$$\begin{aligned} \alpha^{(\ell, 1-c)} &\geq \alpha_{\varphi_{\text{lin}}^{(\ell, 1-c)}}(\ell) = 1 - e^{-\ell} \left( 1 + \sum_{k=1}^{\ell-1} \left( \frac{b(\ell - k)}{\varphi(\ell)} \right) \frac{\ell^k}{k!} - \frac{1-c}{\varphi(\ell)} \frac{\ell^{\ell+1}}{\ell!} \right) \\ &= 1 - e^{-\ell} \left( 1 + \frac{b\ell}{\varphi(\ell)} \sum_{k=1}^{\ell-1} \frac{\ell^k}{k!} - \frac{b\ell}{\varphi(\ell)} \sum_{k=1}^{\ell-1} \frac{\ell^{k-1}}{(k-1)!} - \frac{1-c}{\varphi(\ell)} \frac{\ell^{\ell+1}}{\ell!} \right) \\ &= 1 - \frac{e^{-\ell}}{\varphi(\ell)} \left( \varphi(\ell) + b\ell \left( \frac{\ell^{\ell-1}}{(\ell-1)!} - 1 \right) - (1-c) \frac{\ell^{\ell+1}}{\ell!} \right) \quad (3.21) \\ &= 1 - \frac{e^{-\ell}}{\varphi(\ell)} \left( 1 + b(\ell - 1) + b \left( \frac{\ell^\ell}{(\ell-1)!} - \ell \right) - (1-c) \frac{\ell^{\ell+1}}{\ell!} \right) \\ &= 1 - e^{-\ell} \frac{1 - b + (b - (1-c)) \frac{\ell^{\ell+1}}{\ell!}}{\varphi(\ell)}. \end{aligned}$$

We have also that  $b \geq \varphi(\ell) - \varphi(\ell - 1) \geq 1 - c$  since  $\varphi$  concave. As a function of  $(b - (1 - c))$  for  $c$  fixed, we get  $g(x) := 1 - e^{-\ell} \frac{c + x \left( \frac{\ell^{\ell+1}}{\ell!} - 1 \right)}{1 + (x + (1 - c))(\ell - 1)}$ . In particular, we have that  $\alpha_{\varphi_{\text{lin}}^{(\ell, 1-c)}}(\ell) = g(b - (1 - c))$ , since  $\varphi(\ell) = 1 + b(\ell - 1)$ . We have that

$g'(x) = -e^{-\ell} \frac{\ell \left( \frac{\ell^\ell}{\ell!} - 1 \right) + (1 - c) \frac{\ell^{\ell+1}}{\ell!} (\ell - 1)}{(1 + (x + (1 - c))(\ell - 1))^2} \leq 0$ , so  $g$  is nonincreasing: it is thus enough to show that  $g(c) \geq 1 - ce^{-1}$  to get the result, since  $\alpha^{(\ell, 1-c)} \geq g(b - (1 - c)) \geq g(c) \geq 1 - ce^{-1}$ . But:

$$g(c) = 1 - \frac{c \frac{\ell^{\ell+1}}{\ell!}}{1 + \ell - 1} e^{-\ell} = 1 - c \frac{\ell^\ell}{\ell!} e^{-\ell} \geq 1 - ce^{-1},$$

since  $\frac{\ell^\ell}{\ell!} e^{-\ell}$  is a decreasing sequence. □

**Proposition 3.23.** *Let  $F(x) := \mathbb{E}_{X \sim x} [C^\varphi(X)]$  for  $x \in \{0, 1\}^m$ . We have an explicit formula for  $F$ :*

$$F(x) = \sum_{a=1}^n \sum_{k=0}^m \left[ \frac{1}{m+1} \sum_{\ell=0}^m \omega_{m+1}^{-\ell k} \prod_{j \in [m]: a \in T_j} (1 + (\omega_{m+1}^\ell - 1)x_j) \right] \varphi(k),$$

with  $\omega_{m+1} := \exp\left(\frac{2i\pi}{m+1}\right)$ . Thus,  $F$  is computable in polynomial time in  $n$  and  $m$ .

*Proof.* Recall that  $C^\varphi(S) = \sum_{a=1}^n C_a^\varphi(S)$ , so by linearity of expectation we focus on  $\mathbb{E}_{X \sim x}[C_a^\varphi(X)]$ . But  $C_a^\varphi(X) = \varphi(|X|_a)$  where  $|X|_a = |\{i \in [m] : X_i = 1 \text{ and } a \in T_i\}|$ . Thus:

$$\mathbb{E}_{X \sim x}[C_a^\varphi(X)] = \sum_{k=0}^m \mathbb{P}_{X \sim x}(|X|_a = k) \varphi(k).$$

Let us compute the distribution of  $|X|_a$ . We have  $|X|_a = \sum_{i \in [m]: a \in T_i} X_i$  and  $X_i \sim \text{Ber}(x_i)$ . Thus,  $|X|_a \sim \text{Poi Bin}((x_i)_{i \in [m]: a \in T_i})$ , which is known as the Poisson binomial law. Thanks to [FW10], we have that:

$$\mathbb{P}_{X \sim x}(|X|_a = k) = \frac{1}{m+1} \sum_{\ell=0}^m \omega_{m+1}^{-\ell k} \prod_{j \in [m]: a \in T_j} (1 + (\omega_{m+1}^\ell - 1)x_j),$$

where  $\omega_{m+1} := \exp\left(\frac{2i\pi}{m+1}\right)$ , and the result is proved.  $\square$

**Proposition 3.24.** *We have that*

$$|\mathbb{E}[\varphi(\text{Bin}(n, x/n))] - \mathbb{E}[\varphi(\text{Poi}(x))]| \leq \frac{x\varphi(n)}{2n} + \frac{x^{n+1}}{n!}.$$

In particular when  $\varphi(n) = o(n)$ :

$$\lim_{n \rightarrow \infty} \mathbb{E}[\varphi(\text{Bin}(n, x_\varphi/n))] = \mathbb{E}[\varphi(\text{Poi}(x_\varphi))] = \alpha_\varphi \varphi(x_\varphi).$$

*Proof.* Thanks to [BH84, TT19], the total variation distance between  $\text{Bin}(n, x/n)$  and  $\text{Poi}(x)$  is bounded in the following way:

$$\Delta(\text{Bin}(n, x/n), \text{Poi}(x)) \leq \frac{1 - e^{-x}}{2x} n \cdot \left(\frac{x}{n}\right)^2 \leq \frac{x}{2n}.$$

Thus with  $B \sim \text{Bin}(n, x/n)$  and  $P \sim \text{Poi}(x)$ :

$$\begin{aligned} |\mathbb{E}[\varphi(B)] - \mathbb{E}[\varphi(P)]| &= \left| \sum_{k=0}^{+\infty} \varphi(k) \mathbb{P}(B = k) - \sum_{k=0}^{+\infty} \varphi(k) \mathbb{P}(P = k) \right| \\ &= \left| \sum_{k=0}^{+\infty} \varphi(k) (\mathbb{P}(B = k) - \mathbb{P}(P = k)) \right| \\ &\leq \sum_{k=0}^{+\infty} \varphi(k) |\mathbb{P}(B = k) - \mathbb{P}(P = k)| \\ &\leq \varphi(n) \Delta(\text{Bin}(n, x/n), \text{Poi}(x)) + \sum_{k=n+1}^{+\infty} \varphi(k) \mathbb{P}(P = k) \quad (3.22) \\ &\leq \frac{x\varphi(n)}{2n} + e^{-x} \sum_{k=n+1}^{+\infty} k \frac{x^k}{k!} \quad \text{since } \varphi(k) \leq k \\ &= \frac{x\varphi(n)}{2n} + x e^{-x} \sum_{k=n}^{+\infty} \frac{x^k}{k!} \\ &\leq \frac{x\varphi(n)}{2n} + \frac{x^{n+1}}{n!} \xrightarrow{n \rightarrow \infty} 0 \text{ when } \varphi(n) = o(n), \end{aligned}$$

by a standard upper bound on the remainder of the exponential series.  $\square$

**Proposition 3.25.** *The function  $g : x \mapsto \mathbb{E}[\varphi(\text{Poi}(x))]$  on  $\mathbb{R}^+$  is  $C^\infty$  nondecreasing concave.*

*Proof.* Since we have that  $0 \leq \varphi(k) \leq k$  for  $k \in \mathbb{N}$ , in particular  $g(x) = e^{-x} \sum_{k=0}^{+\infty} \varphi(k) \frac{x^k}{k!}$  is  $C^\infty$ . It is thus enough to compute its first and second derivatives:

$$\begin{aligned} g'(x) &= -e^{-x} \sum_{k=0}^{+\infty} \varphi(k) \frac{x^k}{k!} + e^{-x} \sum_{k=1}^{+\infty} \varphi(k) k \frac{x^{k-1}}{k!} \\ &= -e^{-x} \sum_{k=0}^{+\infty} \varphi(k) \frac{x^k}{k!} + e^{-x} \sum_{k=0}^{+\infty} \varphi(k+1) \frac{x^k}{k!} \\ &= e^{-x} \sum_{k=0}^{+\infty} (\varphi(k+1) - \varphi(k)) \frac{x^k}{k!}. \end{aligned} \tag{3.23}$$

But  $\varphi(k+1) - \varphi(k) \geq 0$  since  $\varphi$  nondecreasing, so  $g'(x) \geq 0$  and  $g$  is nondecreasing.

The calculus of  $g''$  is the same where we replace  $\varphi$  by  $\psi(k) := \varphi(k+1) - \varphi(k)$  which is a nonincreasing function by concavity of  $\varphi$ . Thus:

$$g''(x) = e^{-x} \sum_{k=0}^{+\infty} (\psi(k+1) - \psi(k)) \frac{x^k}{k!} \leq 0.$$

since  $\psi(k+1) - \psi(k) \leq 0$ , and so  $g$  is concave.  $\square$

**Proposition 3.26.** *The function  $g_q : n \mapsto \mathbb{E}[\varphi(\text{Bin}(n, q))]$  defined on  $\mathbb{N}$  is nondecreasing concave. As a consequence, one can use Jensen's inequality on the piecewise linear extension of  $g_q$  which is also continuous.*

*Proof.* We have  $\text{Bin}(n, q) \leq_{\text{st}} \text{Bin}(n+1, q)$  and  $\mathbb{E}[\varphi(\text{Bin}(n, q))] \leq \mathbb{E}[\varphi(\text{Bin}(n+1, q))]$  since  $\varphi$  is nondecreasing, ie  $g_q(n+1) - g_q(n) \geq 0$ :  $g_q$  is nondecreasing.

We show then the concavity, i.e.  $g_q(n+2) - g_q(n+1) \leq g_q(n+1) - g_q(n)$ . Let us define  $\psi(x) = \varphi(x+1) - \varphi(x)$ , which is nonincreasing since  $\varphi$  concave. Let us take  $X_{k,q} \sim \text{Bin}(k, q)$ . Then:

$$\begin{aligned} g_q(n+1) &= \mathbb{E}[\varphi(X_{n+1,q})] \\ &= \sum_{i=0}^n \mathbb{E}[\varphi(X_{n,q} + X_{1,q}) | X_{n,q} = i] \mathbb{P}(X_{n,q} = i) \\ &= \sum_{i=0}^n \mathbb{E}[\varphi(i + X_{1,q}) - \varphi(i)] \mathbb{P}(X_{n,q} = i) + \sum_{i=0}^n \varphi(i) \mathbb{P}(X_{n,q} = i) \\ &= \sum_{i=0}^n \mathbb{E}[\varphi(i + X_{1,q}) - \varphi(i)] \mathbb{P}(X_{n,q} = i) + g_q(n). \end{aligned} \tag{3.24}$$



Thus:

$$\begin{aligned}
 g_q(n+1) - g_q(n) &= \sum_{i=0}^n \mathbb{E}[\varphi(i + X_{1,q}) - \varphi(i)] \mathbb{P}(X_{n,q} = i) \\
 &= \sum_{i=0}^n q(\varphi(i+1) - \varphi(i)) \mathbb{P}(X_{n,q} = i) \\
 &= q \mathbb{E}[\psi(\text{Bin}(n, q))] .
 \end{aligned} \tag{3.25}$$

Then thanks to the fact that  $\text{Bin}(n, q) \leq_{\text{st}} \text{Bin}(n+1, q)$  and  $\psi$  is nonincreasing, we have that  $\mathbb{E}[\psi(\text{Bin}(n, q))] \geq \mathbb{E}[\psi(\text{Bin}(n+1, q))]$ , i.e.  $g_q(n+2) - g_q(n+1) \leq g_q(n+1) - g_q(n)$ .  $\square$

**Proposition 3.27.** *With  $w_i := \varphi(i) - \varphi(i-1)$ , we have:*

$$\lim_{i \rightarrow +\infty} w_i = 0 \iff \varphi(n) = o(n) .$$

*Proof.* ( $\Rightarrow$ ) Let  $\epsilon > 0$ , let us find a rank  $N$  such that for  $n \geq N$ ,  $\frac{\varphi(n)}{n} \leq \epsilon$ . Let  $N_0$  the rank from which  $w_i \leq \frac{\epsilon}{2}$  and  $N_1$  the rank from which  $\frac{1}{n} \sum_{i=1}^{N_0-1} w_i \leq \frac{\epsilon}{2}$ . We have

$$\begin{aligned}
 \frac{\varphi(n)}{n} &= \frac{1}{n} \sum_{i=1}^n w_i \leq \frac{1}{n} \sum_{i=1}^{N_0-1} w_i + \frac{1}{n} \sum_{i=N_0}^{n-1} \frac{\epsilon}{2} \\
 &\leq \frac{\epsilon}{2} + \frac{\epsilon}{2} = \epsilon \text{ for } n \geq \max(N_0, N_1) =: N .
 \end{aligned} \tag{3.26}$$

( $\Leftarrow$ ) Since  $w_i = \varphi(i) - \varphi(i-1)$  is nonnegative and nonincreasing (respectively because  $\varphi$  is nondecreasing and concave), then the sequence  $w$  has a limit  $L \geq 0$ . But

$$\frac{\varphi(n)}{n} = \frac{1}{n} \sum_{i=1}^n w_i \geq L .$$

Since the left hand side tends to 0 by hypothesis, this means that  $L = 0$ .  $\square$

**Proposition 3.28.** *If  $w_i := \varphi(i) - \varphi(i-1)$  is geometrically dominant, i.e. it satisfies  $\forall i \in \mathbb{N}^*, \frac{w_i}{w_{i+1}} \geq \frac{w_{i+1}}{w_{i+2}}$ , then  $\alpha_\varphi = \alpha_\varphi(1)$ .*

*Remark.* Proposition 3.28 and in particular its proof uses similar ideas to the sketch provided in [DMMS20].

*Proof.* Let  $g(k) := \mathbb{E}[\varphi(\text{Poi}(k))]$ , and thus  $\alpha_\varphi(k) = \frac{g(k)}{\varphi(k)}$ . Let us show that for  $k \in \mathbb{N}^*$ ,  $\alpha_\varphi(k) \geq \alpha_\varphi(1)$ , which will be enough to conclude. In order to show this, we will need the following lemmas:

**Lemma 3.29.**  $\forall k < i \in \mathbb{N}, w_i \geq w_{k+1} w_{i-k}$  and thus  $\forall k, j \in \mathbb{N}, \varphi(k+j) - \varphi(k) \geq w_{k+1} \varphi(j)$ .

*Proof.* We have that:

$$w_i = \frac{w_i}{w_{i-1}} \frac{w_{i-1}}{w_{i-2}} \dots \frac{w_{i-k+1}}{w_{i-k}} w_{i-k}.$$

But for  $j \in [k]$ :

$$\frac{w_{i-j+1}}{w_{i-j}} \geq \frac{w_{(i-1)-j+1}}{w_{(i-1)-j}} \geq \dots \geq \frac{w_{(k+1)-j+1}}{w_{(k+1)-j}},$$

since  $w$  is geometrically dominant and  $k+1 \leq i$ . Thus applying this bound on each term of the previous product, we get:

$$w_i \geq \frac{w_{k+1}}{w_k} \frac{w_k}{w_{k-1}} \dots \frac{w_2}{w_1} w_{i-k} = \frac{w_{k+1}}{w_1} w_{i-k} = w_{k+1} w_{i-k}.$$

In particular,  $\forall k, j \in \mathbb{N}$ , we get:

$$\varphi(k+j) - \varphi(k) = \sum_{i=k+1}^{k+j} w_i \geq w_{k+1} \sum_{i=1}^j w_i = w_{k+1} \varphi(j).$$

□

**Lemma 3.30.** *The piecewise linear extension on  $[1, +\infty[$  of  $w$ , defined on integers with  $w(k) := w_k$ , is convex.*

*Proof.* We will show that  $\forall k \in \mathbb{N}^*$ ,  $w_{k+2} - w_{k+1} \geq w_{k+1} - w_k$  which implies the convexity of its piecewise linear extension on  $[1, +\infty[$ . For  $k \in \mathbb{N}^*$  we have:

$$\frac{w_{k+1}}{w_{k+2}} - 1 \leq \frac{w_{k+1}}{w_{k+2}} \left( \frac{w_{k+1}}{w_{k+2}} - 1 \right) \leq \frac{w_{k+1}}{w_{k+2}} \left( \frac{w_k}{w_{k+1}} - 1 \right) = \frac{w_k - w_{k+1}}{w_{k+2}},$$

since  $w$  is nonnegative nonincreasing (respectively  $\varphi$  nondecreasing concave) and  $\frac{w_{k+1}}{w_{k+2}} \leq \frac{w_k}{w_{k+1}}$  since  $w$  is geometrically dominant. Then, multiplying by  $-w_{k+2} \leq 0$  gives the expected result  $w_{k+2} - w_{k+1} \geq w_{k+1} - w_k$ . □

We have  $g(k+1) = \mathbb{E}[\varphi(\text{Poi}(k+1))] = \mathbb{E}[\varphi(\text{Poi}(k) + \text{Poi}(1))]$  since  $\text{Poi}(k+1) \sim \text{Poi}(k) + \text{Poi}(1)$ . Thus:

$$\begin{aligned} g(k+1) - g(k) &= \mathbb{E}_{X, X' \sim \text{Poi}(k), Y \sim \text{Poi}(1)} [\varphi(X+Y) - \varphi(X')] \\ &= \mathbb{E}_{X \sim \text{Poi}(k), Y \sim \text{Poi}(1)} [\varphi(X+Y) - \varphi(X)] \\ &\geq \mathbb{E}_{X \sim \text{Poi}(k), Y \sim \text{Poi}(1)} [w_{X+1} \varphi(Y)] \quad \text{by Lemma 3.29} \\ &= \mathbb{E}_{X \sim \text{Poi}(k)} [w(X+1)] \mathbb{E}_{Y \sim \text{Poi}(1)} [\varphi(Y)], \end{aligned} \tag{3.27}$$

by independence of  $w(X+1)$  and  $\varphi(Y)$ . Since  $w$  is convex on  $[1, +\infty[$  by Lemma 3.30 and  $\text{Poi}(k) + 1 \in [1, +\infty[$ , we have that  $\mathbb{E}[w(\text{Poi}(k) + 1)] \geq w(\mathbb{E}[\text{Poi}(k) + 1]) = w(k+1) = w_{k+1}$  thanks to Jensen's inequality. Note that  $g(0) = \mathbb{E}[\varphi(\text{Poi}(0))] = \varphi(0) = 0$ . Then:

$$g(k) = \sum_{i=0}^{k-1} g(i+1) - g(i) \geq \left( \sum_{i=0}^{k-1} w_{i+1} \right) \mathbb{E}[\varphi(\text{Poi}(1))] = \varphi(k) g(1).$$

Therefore:

$$\alpha_\varphi(k) = \frac{g(k)}{\varphi(k)} \geq g(1) = \frac{g(1)}{\varphi(1)} = \alpha_\varphi(1).$$

□

### 3.5.2 Calculations of $\alpha_\varphi$

**Proposition 3.31.** For  $\ell \in \mathbb{N}^*$  and  $\varphi(j) = \min(j, \ell)$ , we have that  $\alpha_\varphi = 1 - \frac{\ell^\ell e^{-\ell}}{\ell!}$ .

*Proof.* Thanks to Proposition 3.22, we have that  $\alpha_\varphi = \min_{x \in \mathbb{N}^*} \alpha_\varphi(x)$ . Let us compute  $\mathbb{E}[\varphi(\text{Poi}(x))]$ :

$$\begin{aligned}
\mathbb{E}[\varphi(\text{Poi}(x))] &= e^{-x} \sum_{k=0}^{+\infty} \varphi(k) \frac{x^k}{k!} \\
&= e^{-x} \sum_{k=0}^{\ell} k \frac{x^k}{k!} + e^{-x} \sum_{k=\ell+1}^{+\infty} \ell \frac{x^k}{k!} \\
&= e^{-x} x \sum_{k=0}^{\ell-1} \frac{x^k}{k!} + \ell e^{-x} \sum_{k=\ell+1}^{+\infty} \frac{x^k}{k!} \\
&= e^{-x} \left[ (x - \ell) \sum_{k=0}^{\ell-1} \frac{x^k}{k!} - \ell \frac{x^\ell}{\ell!} \right] + \ell e^{-x} \sum_{k=0}^{+\infty} \frac{x^k}{k!} \\
&= \ell - e^{-x} \left[ \frac{x^\ell}{(\ell-1)!} - (x - \ell) \sum_{k=0}^{\ell-1} \frac{x^k}{k!} \right].
\end{aligned} \tag{3.28}$$

Let us show that  $x \mapsto \alpha_\varphi(x)$  takes its minimum in  $\ell$ , where we have indeed:

$$\alpha_\varphi(\ell) = \frac{1}{\ell} \left( \ell - e^{-\ell} \left[ \frac{\ell^\ell}{(\ell-1)!} - (\ell - \ell) \sum_{k=0}^{\ell-1} \frac{\ell^k}{k!} \right] \right) = 1 - e^{-\ell} \frac{\ell^\ell}{\ell!}.$$

Thanks to proposition 3.21,  $x \mapsto \alpha_\varphi(x)$  is nondecreasing from  $\ell$  to  $+\infty$ . Suppose now that  $\ell \geq 2$  (otherwise the result is already proved). Since  $x \mapsto \alpha_\varphi(x)$  is differentiable, we have

for  $1 \leq x \leq \ell$ :

$$\begin{aligned}
 \alpha'_\varphi(x) &= -\frac{\ell}{x^2} + e^{-x} \left[ \frac{x^{\ell-1}}{(\ell-1)!} - \sum_{k=0}^{\ell-1} \frac{x^k}{k!} + \ell \sum_{k=0}^{\ell-2} \frac{x^k}{(k+1)!} + \frac{\ell}{x} \right] \\
 &\quad - e^{-x} \left[ \frac{x^{\ell-2}}{(\ell-2)!} - \sum_{k=0}^{\ell-2} \frac{x^k}{k!} + \ell \sum_{k=0}^{\ell-3} \frac{x^k}{(k+2)k!} - \frac{\ell}{x^2} \right] \\
 &= \frac{\ell}{x} \left( e^{-x} \left( 1 + \frac{1}{x} \right) - \frac{1}{x} \right) \\
 &\quad + e^{-x} \left[ \left( \frac{\ell}{\ell-1} - 1 \right) \frac{x^{\ell-2}}{(\ell-2)!} + \ell \sum_{k=0}^{\ell-3} \left( \frac{x^k}{(k+1)!} - \frac{x^k}{(k+2)k!} \right) \right] \\
 &= \frac{\ell}{x} \left( e^{-x} \left( 1 + \frac{1}{x} \right) - \frac{1}{x} \right) + e^{-x} \left[ \frac{x^{\ell-2}}{(\ell-1)!} + \ell \sum_{k=0}^{\ell-3} \frac{x^k}{k!} \left( \frac{1}{k+1} - \frac{1}{k+2} \right) \right] \\
 &= \frac{\ell}{x} \left( e^{-x} \left( 1 + \frac{1}{x} + \frac{x^{\ell-1}}{\ell!} + x \sum_{k=0}^{\ell-3} \frac{x^k}{k!} \frac{1}{(k+1)(k+2)} \right) - \frac{1}{x} \right) \\
 &= \frac{\ell e^{-x}}{x^2} \left( \left( 1 + x + \frac{x^\ell}{\ell!} + \sum_{k=0}^{\ell-3} \frac{x^{k+2}}{(k+2)!} \right) - e^x \right) \\
 &= \frac{\ell e^{-x}}{x^2} \left( \sum_{k=0}^{\ell} \frac{x^k}{k!} - e^x \right) \leq 0.
 \end{aligned} \tag{3.29}$$

since the partial sum of the exponential series is bounded by its total sum. Thus  $\alpha_\varphi(x)$  is nonincreasing from 1 to  $\ell$ , and nondecreasing after, so it takes indeed its minimum in  $\ell$  and the proposition is proved.  $\square$

**Proposition 3.32.** For  $p \in (0, 1)$  and  $\varphi(j) = \frac{1-(1-p)^j}{p}$ , we have that  $\alpha_\varphi = \frac{1-e^{-p}}{p}$ .

*Proof.* By definition:

$$\begin{aligned}
 \alpha_\varphi(x) &= \frac{\mathbb{E}[\varphi(\text{Poi}(x))]}{\varphi(x)} = \frac{\sum_{k=0}^{+\infty} \varphi(k) e^{-x} \frac{x^k}{k!}}{\varphi(x)} \\
 &= \frac{1 - e^{-x} \sum_{k=0}^{+\infty} (1-p)^k \frac{x^k}{k!}}{p\varphi(x)} \\
 &= \frac{1 - e^{-x} e^{(1-p)x}}{p\varphi(x)} = \frac{1 - e^{-px}}{p\varphi(x)}.
 \end{aligned} \tag{3.30}$$

If  $x \geq 1$ ,  $\alpha_\varphi(x) = \frac{1-e^{-px}}{1-(1-p)^x} = \frac{1-e^{-px}}{1-e^{-qx}}$  with  $q = \ln\left(\frac{1}{1-p}\right) > 0$  and:

$$\alpha'_\varphi(x) = \frac{pe^{-px}(1-e^{-qx}) - qe^{-qx}(1-e^{-px})}{(1-e^{-qx})^2} = \frac{pe^{-px} - qe^{-qx} + (q-p)e^{-(p+q)x}}{(1-e^{-qx})^2}.$$

Let us take  $t = \frac{p}{q} \in (0, 1)$ , since  $q = \ln\left(\frac{1}{1-p}\right) > p > 0$ ,  $x_1 = -px$  and  $x_2 = -(p+q)x$ . Then by strict convexity of the exponential function, we have:

$$e^{tx_1+(1-t)x_2} < te^{x_1} + (1-t)e^{x_2} = \frac{pe^{-px} + (q-p)e^{-(p+q)x}}{q}.$$

But  $tx_1 + (1-t)x_2 = \frac{-p^2x}{q} + \frac{-(q-p)(p+q)x}{q} = \frac{-p^2x}{q} + \frac{-(q^2x-p^2x)}{q} = -qx$ , so we get  $pe^{-px} - qe^{-qx} + (q-p)e^{-(p+q)x} > 0$ , and  $\alpha'_\varphi(x) > 0$ . Thus,  $\alpha_\varphi(x)$  increases from 1 to infinity and takes its minimum in 1:

$$\alpha_\varphi = \alpha_\varphi(1) = \frac{1 - e^{-p}}{p}.$$

□

**Proposition 3.33.** For  $d \in (0, 1)$  and  $\varphi(j) = j^d$ , we have that  $\alpha_\varphi = e^{-1} \sum_{k=1}^{+\infty} \frac{k^d}{k!}$ .

*Proof.* We have for  $x \geq 1$ :

$$\alpha_\varphi(x) = \frac{\mathbb{E}[\text{Poi}(x)^d]}{\varphi(x)} = \frac{e^{-x} \sum_{k=0}^{+\infty} k^d \frac{x^k}{k!}}{\varphi(x)} = e^{-x} \sum_{k=0}^{+\infty} k^d \frac{x^{k-d}}{k!}.$$

Then:

$$\begin{aligned} \alpha'_\varphi(x) &= -\alpha_\varphi(x) + e^{-x} \sum_{k=1}^{+\infty} (k-d) k^d \frac{x^{k-d-1}}{k!} \\ &= -\alpha_\varphi(x) + e^{-x} \sum_{k=0}^{+\infty} (k+1-d)(k+1)^d \frac{x^{k-d}}{(k+1)!} \\ &= -\alpha_\varphi(x) + e^{-x} \left( (1-d)x^{-d} + \sum_{k=1}^{+\infty} (k+1-d)(k+1)^{d-1} \frac{x^{k-d}}{k!} \right) \\ &= e^{-x} x^{-d} \left( 1-d + \sum_{k=1}^{+\infty} \left( \frac{k+1-d}{k+1} (k+1)^d - k^d \right) \frac{x^k}{k!} \right). \end{aligned} \tag{3.31}$$

But the function  $f(k) = \frac{k+1-d}{k+1} (k+1)^d - k^d$  is positive on  $\mathbb{R}_+^*$ , so we get that  $\alpha'_\varphi(x) > 0$  for  $x \geq 1$ , thus  $\alpha_\varphi(x)$  is increasing from 1 to  $+\infty$ , so  $\alpha_\varphi = \alpha_\varphi(1) = e^{-1} \sum_{k=1}^{+\infty} \frac{k^d}{k!}$ . □

### 3.5.3 NP-hardness of $\delta, h$ -ARYGAPLABELCOVER

*Proof of Proposition 3.5.* We reduce from the Label Cover problem described in [DMMS20] which is known to be an NP-hard problem. The main idea of this reduction is the usual equivalence between bipartite graphs and hypergraphs.

**Definition 3.5.** A Label Cover instance  $\mathcal{L} = (A \sqcup B, E, [L], [R], \{\pi_e\}_{e \in E})$  consists of a bi-regular bipartite graph  $(A \sqcup B, E)$  with right degree  $t$ , alphabet sets  $[L], [R]$  and for every edge  $e \in E$ , a constraint  $\pi_e : [L] \rightarrow [R]$ . A *labeling* of  $\mathcal{L}$  is a function  $\sigma : A \rightarrow [L]$ . We say that  $\sigma$  *strongly satisfies* a right vertex  $v \in B$  if for every two neighbors  $u, u'$  of  $v$ , we have  $\pi_{(u,v)}(\sigma(u)) = \pi_{(u',v)}(\sigma(u'))$ . Moreover, we say that  $\sigma$  *weakly satisfies* a right vertex  $v \in B$  if there exists two neighbors  $u, u'$  of  $v$  such that  $\pi_{(u,v)}(\sigma(u)) = \pi_{(u',v)}(\sigma(u'))$ .

**Theorem 3.34** ( $\delta$ -Gap-Label-Cover( $t, R$ ) from [DMMS20]). For any fixed integer  $t \geq 2$  and fixed  $\delta > 0$ , there exists  $R_0$  such that for any integer  $R \geq R_0$ , it is NP-hard for Label Cover instances  $\mathcal{L} = (A \sqcup B, E, [L], [R], \{\pi_e\}_{e \in E})$  with right degree  $t$  and right alphabet  $[R]$  to distinguish between:

**YES:** *There exists a labeling  $\sigma$  that strongly satisfies all the right vertices.*

**NO:** *No labeling weakly satisfies more than  $\delta$  fraction of the right vertices.*

The reduction is the following. From  $\delta$ -Gap-Label-Cover( $t, R$ ), we take  $h = t$  and the same parameters  $\delta, R$ . Given an instance  $\mathcal{L} = (A \sqcup B, E, [L], [R], \{\pi_e\}_{e \in E})$ , we take  $\mathcal{G} = (A, E', [L], [R], \{\pi'_{e',v}\}_{e' \in E', v \in e'})$  with  $E' = \{N(b), b \in B\}$  with  $N(b)$  the set of neighbors of  $b$  in  $\mathcal{L}$ , and  $\pi'_{e',v} = \pi'_{N(b),v} := \pi_{v,b}$  since  $v \in N(b)$ . Since  $(A \sqcup B, E)$  is bipartite and biregular, we get that our hypergraph has all hyperedges of size  $h = |N(b)| = t$ , and that it is regular from the regular left degree of  $(A \sqcup B, E)$ . By construction, the notion of weakly and strongly satisfied is the same in both cases, as well as the labelings, and thus we have the NP-hardness of  $\delta, h$ -ARYGAPLABELCOVER.

Note that both problems are in fact linearly equivalent since we could do the same reduction backwards. □

### 3.5.4 Proof of Existence of Partitioning Systems

*Proof of Proposition 3.6.* The existential proof is based on the probabilistic method. We take  $\mathcal{P}_i$  an  $h$ -equi-sized uniform random  $x_\varphi$ -cover of  $[n]$ . Hence in the collection  $\mathcal{P}_i = (P_{i,1}, \dots, P_{i,h})$ , each of the  $h$  subsets is of cardinality  $\frac{x_\varphi n}{h}$ . Write  $\mathcal{P} = (\mathcal{P}_1, \dots, \mathcal{P}_R)$ . We have that for any  $a \in [n]$ ,  $\mathbb{P}(a \in P_{i,j}) = \frac{x_\varphi}{h}$ . Note that these events are independent for different  $i$ s.

By construction, the first condition is fulfilled. Let us prove the second one.

Fix  $T \subseteq [R]$  and  $\mathcal{Q} := \{P_{i,j(i)} : i \in T\}$  for some function  $j : T \rightarrow [h]$ . We have for  $a \in [n]$ :

$$\mathbb{E}[C_a^\varphi(\mathcal{Q})] = \mathbb{E}[\varphi(|\mathcal{Q}|_a)] = \mathbb{E}\left[\varphi\left(\left|\{i \in T : a \in P_{i,j(i)}\}\right|\right)\right].$$

But the random variables  $\{X_i^a := \mathbb{1}_{a \in P_{i,j(i)}}\}_{i \in T}$  are independent and  $X_i^a \sim \text{Ber}(\frac{x_\varphi}{h})$ , so  $X^a := \left|\{i \in T : a \in P_{i,j(i)}\}\right| = \sum_{i \in T} X_i^a \sim \text{Bin}(|T|, \frac{x_\varphi}{h})$ , and thus:

$$\mathbb{E}[C_a^\varphi(\mathcal{Q})] = \mathbb{E}\left[\varphi\left(\text{Bin}\left(|T|, \frac{x_\varphi}{h}\right)\right)\right] = \psi_{|T|,h}^\varphi.$$

Since  $|\mathcal{Q}|_a \leq |\mathcal{Q}| \leq R$  and  $\varphi$  nondecreasing, we have  $0 \leq C_a^\varphi(\mathcal{Q}) \leq \varphi(R)$ . The random variables  $\{C_a^\varphi(\mathcal{Q})\}_{a \in [n]}$  are not independent in general. However, we will show that they are negatively associated (see Definition 2.2), thus we can apply the version of the Chernoff-Hoeffding bound described in Proposition 2.9 to get:

$$\mathbb{P}\left(\left|\frac{1}{n} \sum_{a \in [n]} C_a^\varphi(\mathcal{Q}) - \psi_{|T|,h}^\varphi\right| > \eta\right) \leq 2 \exp\left(-2 \left(\frac{\eta}{\varphi(R)}\right)^2 n\right).$$

Note that  $C_a^\varphi(\mathcal{Q}) = \varphi(|\mathcal{Q}|_a) = \varphi(X^a)$  is a nondecreasing function of  $\{X_i^a\}_{i \in [R]}$ , since  $\varphi$  is nondecreasing and  $X^a = \sum_{i \in T} X_i^a$ . Thus in order to show that  $\{C_a^\varphi(\mathcal{Q})\}_{a \in [n]}$  are negatively associated, it suffices to show that  $\{X_i^a\}_{i \in [R], a \in [n]}$  are negatively associated by Proposition 2.6.

For fixed  $i \in [R]$ ,  $\{X_i^a\}_{a \in [n]}$  are negatively associated because it corresponds to a permutation distribution of  $(0, \dots, 0, 1, \dots, 1)$ , with  $n - \frac{x_\varphi n}{h}$  zeros and  $\frac{x_\varphi n}{h}$  ones, since it describes a random subset of size  $\frac{x_\varphi n}{h}$ ; see Definition 2.3 and Proposition 2.8. Then, using the fact that the families  $\{X_i^a\}_{a \in [n]}$  are mutually independent, we obtain that  $\{X_i^a\}_{i \in [R], a \in [n]}$  are negatively associated by Proposition 2.7.

Since there are at most  $(h+1)^R$  choices of  $T$  and  $\mathcal{Q}$ , a union bound gives:

$$\mathbb{P}\left(\exists C, \mathcal{Q} : \left|C^\varphi(\mathcal{Q}) - \psi_{|T|, h}^\varphi n\right| > \eta n\right) \leq 2(h+1)^R \exp\left(-2\left(\frac{\eta}{\varphi(R)}\right)^2 n\right).$$

Thus with probability at least 9/10, we have that  $\left|C^\varphi(\mathcal{Q}) - \psi_{|T|, h}^\varphi n\right| \leq \eta n$ , since we have taken  $n \geq \eta^{-2} R \varphi(R)^2 \log(20(h+1))$ . So there must exist some choice of  $\mathcal{P}$  that satisfies the first and second constraints of partitioning systems. Thus, we can enumerate over all choices of  $\mathcal{P}$  in time  $\exp(Rn \log(n)) \cdot \text{poly}(h)$  to find such a partitioning system.  $\square$

### 3.5.5 Proof of Theorem 3.15

*Proof.* We show that  $\varphi$ -RESOURCE ALLOCATION corresponds to  $\varphi$ -MAXCOVERAGE under a matroid constraint. Given an instance of  $\varphi$ -RESOURCE ALLOCATION, consider the partition matroid  $\mathcal{M}$  on  $[\sum_{i \in [k]} m_i] := [m_1] + \dots + [m_k]$ , where  $(B_i)_{i \in [k]} := ([m_i])_{i \in [k]}$  is a partition of the ground set and the cardinality constraint for each  $i$  is to  $d_i = 1$ .

Here,  $I \subseteq [\sum_{i \in [k]} m_i]$  is an independent set of the matroid if and only if  $|I \cap B_i| \leq d_i = 1$ , for all  $i \in [k]$ . This corresponds to each agent  $i \in [k]$  selecting at most one element from the available  $m_i$  choices. In other words, we have a bijection  $f$  between tuples  $(A_1, \dots, A_k) \in \mathcal{A}_1 \times \dots \times \mathcal{A}_k$  and maximal independent sets (bases) of  $\mathcal{M}$  such that  $W^\varphi(A) = C^\varphi(f(A))$ . Therefore, Theorem 3.3 leads to a polynomial-time  $\alpha_\varphi$ -approximation algorithm for  $\varphi$ -RESOURCE ALLOCATION.

For the hardness part of the theorem, the proof is exactly the same as in Theorem 3.4, but instead of  $\mathcal{F} := \{F_\beta^v, v \in V, \beta \in [L]\}$  and  $k = |V|$ , we take  $k = |V|$  to be the number of agents and  $\mathcal{A}_i := \{F_\beta^{v_i}, \beta \in [L]\}$  where  $V = \{v_1, \dots, v_k\}$ . Hence, instead of subsets of  $\mathcal{F}$  of size  $k$ , we only consider one set  $F_\beta^{v_i} \in \mathcal{F}$ , for each  $v \in V$ . The function we maximize in the reduction remains unchanged.

To establish completeness, we note that the subset described is already of the right form and, hence, the arguments continue to hold. For proving soundness, the constraint on the shape of the subset of  $\mathcal{F}$  only helps us, since it gives more constraints on the given subset from which we want to construct a labeling. Therefore, the NP-hardness follows.  $\square$





---

# Multiple-Access Channel Coding With Non-Signaling Correlations

Multiple-access channels (MACs for short) are one of the simplest models of network communication settings, where two senders aim to transmit individual messages to one receiver. The capacity of such channels has been entirely characterized by the seminal works by Liao [Lia73] and Ahlswede [Ahl73] in terms of a simple single-letter formula. From the point of view of quantum information, it is natural to ask whether additional resources, such as quantum entanglement or more generally non-signaling correlations between the parties, change the capacity region. A non-signaling correlation is a multipartite input-output box shared between parties that, as the name suggests, cannot by itself be used to send information between parties. However, non-signaling correlations such as the ones generated by measurements of entangled quantum particles, can provide an advantage for various information processing tasks and nonlocal games. The study of such correlations has given rise to the quantum information area known as nonlocality [BCP<sup>+</sup>14]. For example, in the context of channel coding, there exists classical point-to-point channels for which quantum entanglement between the sender and the receiver can increase the optimal success probability for sending one bit of information with a single use of the channel [PLM<sup>+</sup>11, BF18]. However, for classical point-to-point channels, entanglement [BBC<sup>+</sup>93, BSST99] and even more generally non-signaling correlations [Mat12] do not change the capacity of the channel.

In the network setting, behavior is different. Quek and Shor showed in [QS17] the existence of two-sender two-receiver interference channels with gaps between their classical, quantum-entanglement assisted and non-signaling assisted capacity regions. Following this result, Leditzky et al. [LALS20, SLSS22] showed that quantum entanglement shared between the two senders of a MAC can strictly enlarge the capacity region. This has been demonstrated through channels that are constructed from two-player nonlocal games, such as the Magic Square game [Mer90, Per90, Ara02, BBT05], by translating known gaps between classical and quantum values of games into MAC capacity gaps. Other instances of network channels for which entanglement increases the capacity region were studied in [Noe20, ND20, YRB20, YRB23]. This raises the following natural question: Can non-signaling correlations lead to significant gains in capacity for natural MACs? Can we find a characterization of the capacity region of the MAC when non-signaling resources between the parties are allowed?

**Contributions** We focus here on the MAC with two senders and we allow arbitrary tripartite non-signaling correlations between the two senders and the receiver. This is the most optimistic setting, in the sense that we only enforce the non-signaling constraints between the parties, and also the mathematically simplest setting. Even if not all non-signaling correlations are feasible within quantum theory, the setting we study here can be seen as a tractable and physically motivated outer approximation of what can be achieved with quantum theory. In fact, the quantum set is notoriously complicated and deciding membership in this set is not computable [JNV<sup>+</sup>20]. We note that very recently, Pereg et al. [PDB23] found a regularized characterization for the capacity of MACs with quantum entanglement shared between the two senders. Unfortunately, even the associated single-letter inner bound is very difficult to evaluate for any fixed channel.

We first show that the multiple-access channel coding problem, which entails maximizing the success probability of sending a fixed number of messages through a MAC, cannot be approximated in polynomial time within any constant ratio, under a complexity hypothesis on random  $k$ -SAT formulas; see Theorem 4.5.

We denote by  $S^{\text{NS}}(W, k_1, k_2)$  the success probability of the best non-signaling assisted  $(k_1, k_2)$ -code for the MAC  $W$ . Contrary to the unassisted value that we denote  $S(W, k_1, k_2)$ ,  $S^{\text{NS}}(W, k_1, k_2)$  can be formulated as a linear program; see Proposition 4.7. Furthermore, using symmetries, we have developed a linear program computing  $S^{\text{NS}}$  for a finite number of copies of a MAC  $W$  with a size growing polynomially in the number of copies; see Theorem 4.12 and Corollary 4.13. Using this result, we describe a method to derive inner bounds on the non-signaling assisted capacity region achievable with zero error; see Proposition 4.17. Applied to the binary adder channel, which maps  $(x_1, x_2) \in \{0, 1\}^2$  to  $x_1 + x_2 \in \{0, 1, 2\}$ , we show that the sum-rate  $\frac{\log_2(72)}{4} \simeq 1.5425$  can be reached with zero error, which beats the maximum classical sum-rate capacity of  $\frac{3}{2}$ ; see Theorem 4.18. For noisy channels, where the zero-error non-signaling assisted capacity region is trivial, we can use concatenated codes to obtain achievable points in the capacity region; see Proposition 4.20. Applied to a noisy version of the binary adder channel, we show that non-signaling assistance still improves the sum-rate capacity.

In order to find outer bounds, we define a relaxed notion of non-signaling assistance and characterize its capacity region by a single-letter expression, which is the same as the well-known expression for the capacity of the MAC (see Theorem 4.1) except that the inputs  $X_1$  and  $X_2$  are not required to be independent; see Theorem 4.25. This gives in particular an outer bound on the non-signaling assisted capacity region; see Corollary 4.32. The main open problem that we leave is whether this outer bound on the non-signaling capacity region is tight. We give an example of a channel for which the relaxed notion of non-signaling assistance gives a strictly larger success probability than non-signaling assistance but we do not know if such a gap can persist for the capacity region.

We also study the case where non-signaling assistance is shared only between each sender and the receiver independently. Note that no assistance is shared between the senders. We show that this capacity region is the same as the capacity region without any assistance; see Theorem 4.34 and Corollary 4.35. We note that a similar setting with independent entangled states between each sender and the receiver was studied by Hsieh et al. [HDW08]: a regularized characterization of the capacity region is obtained for any quantum MAC in this setting. It is possible to show using their result that for a classical MAC, this type of entanglement does not change the capacity region given in Theorem 4.1.

**Organization** In Section 4.1, we define precisely the different notions of MAC capacities: the classical capacity (i.e. without any assistance) as well as the non-signaling assisted capacity. In Section 4.2, we show that no polynomial-time constant approximation for multiple-access channel coding exists if a complexity hypothesis on random  $k$ -SAT formulas is true. In Section 4.3, we address computational complexity questions concerning the probability of success of the best classical coding strategy and the best non-signaling strategy for a MAC. In Section 4.4, we develop numerical methods to find inner bounds on non-signaling assisted capacity regions, and apply those to the binary adder channel and a noisy variant. In Section 4.5, we define our relaxation of non-signaling assistance, we characterize its capacity region by a single-letter formula, and apply those to the binary adder channel. Finally, in Section 4.6, we show that the capacity region with non-signaling assistance shared only between each sender and the receiver independently is the same as without assistance.

## 4.1 Multiple-Access Channels Capacity Regions

### 4.1.1 Classical Capacities

The coding problem for a MAC  $W : \mathcal{X}_1 \times \mathcal{X}_2 \rightarrow \mathcal{Y}$  can be stated in the following way. We want to encode messages from  $[k_1]$  into  $\mathcal{X}_1$  and messages from  $[k_2]$  into  $\mathcal{X}_2$  independently. They are given as inputs to  $W$ , which results in a random output in  $\mathcal{Y}$ . From this output, we want to decode back the original messages in  $[k_1]$  and  $[k_2]$ . We will call  $e_1 : [k_1] \rightarrow \mathcal{X}_1$  the first encoder,  $e_2 : [k_2] \rightarrow \mathcal{X}_2$  the second encoder and  $d : \mathcal{Y} \rightarrow [k_1] \times [k_2]$  the decoder. The scenario is depicted in Figure 4.1.

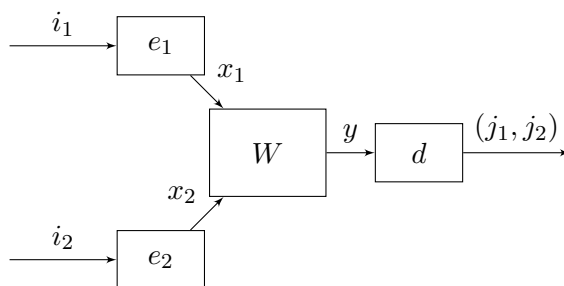

Figure 4.1 – Coding for a MAC  $W$ .

We want to maximize over all encoders  $e_1, e_2$  and decoders  $d$  the probability of successfully encoding and decoding the messages through  $W$ , i.e. the probability that  $j_1 = i_1$  and  $j_2 = i_2$ , given that the input messages are taken uniformly in  $[k_1]$  and  $[k_2]$ . We call this

quantity  $S(W, k_1, k_2)$ , which is characterized by the following optimization program:

$$\begin{aligned}
 S(W, k_1, k_2) := & \underset{e_1, e_2, d}{\text{maximize}} && \frac{1}{k_1 k_2} \sum_{i_1, i_2, x_1, x_2, y} W(y|x_1 x_2) e_1(x_1|i_1) e_2(x_2|i_2) d(i_1 i_2|y) \\
 & \text{subject to} && \sum_{x_1 \in \mathcal{X}_1} e_1(x_1|i_1) = 1, \forall i_1 \in [k_1] \\
 & && \sum_{x_2 \in \mathcal{X}_2} e_2(x_2|i_2) = 1, \forall i_2 \in [k_2] \\
 & && \sum_{j_1 \in [k_1], j_2 \in [k_2]} d(j_1 j_2|y) = 1, \forall y \in \mathcal{Y} \\
 & && e_1(x_1|i_1), e_2(x_2|i_2), d(j_1 j_2|y) \geq 0
 \end{aligned} \tag{4.1}$$

*Proof.* One should note that we allow randomized encoders and decoders for generality reasons, although the value of the program is not changed as it is convex. Besides that remark, let us name  $I_1, I_2, J_1, J_2, X_1, X_2, Y$  the random variables corresponding to  $i_1, i_2, j_1, j_2, x_1, x_2, y$  in the coding and decoding process. Then, for given  $e_1, e_2, d$  and  $W$ , the objective value of the previous program is:

$$\begin{aligned}
 \mathbb{P}(J_1 = I_1, J_2 = I_2) &= \frac{1}{k_1 k_2} \sum_{i_1, i_2} \mathbb{P}(J_1 = I_1, J_2 = I_2 | I_1 = i_1, I_2 = i_2) \\
 &= \frac{1}{k_1 k_2} \sum_{i_1, i_2, x_1, x_2} e_1(x_1|i_1) e_2(x_2|i_2) \mathbb{P}(J_1 = i_1, J_2 = i_2 | i_1, i_2, X_1 = x_1, X_2 = x_2) \\
 &= \frac{1}{k_1 k_2} \sum_{i_1, i_2, x_1, x_2, y} W(y|x_1 x_2) e_1(x_1|i_1) e_2(x_2|i_2) \mathbb{P}(J_1 = i_1, J_2 = i_2 | i_1, i_2, x_1, x_2, Y = y) \\
 &= \frac{1}{k_1 k_2} \sum_{i_1, i_2, x_1, x_2, y} W(y|x_1 x_2) e_1(x_1|i_1) e_2(x_2|i_2) d(i_1, i_2|y).
 \end{aligned} \tag{4.2}$$

□

The (classical) capacity region of a MAC  $W$ , as defined for example in [CT01], can be reformulated in terms of the previous success probability  $S$  using Definition 2.12 and by  $\mathcal{C}(W) := \mathcal{C}[S](W)$ , and its zero-error equivalent is defined by  $\mathcal{C}_0(W) := \mathcal{C}_0[S](W)$ .

The capacity region  $\mathcal{C}(W)$  is characterized by a single-letter formula:

**Theorem 4.1** (Liao [Lia73] and Ahlswede [Ahl73]).  $\mathcal{C}(W)$  is the closure of the convex hull of all rate pairs  $(R_1, R_2)$  satisfying:

$$R_1 < I(X_1 : Y | X_2), \quad R_2 < I(X_2 : Y | X_1), \quad R_1 + R_2 < I((X_1, X_2) : Y),$$

for  $(X_1, X_2) \in \mathcal{X}_1 \times \mathcal{X}_2$  following a product law  $P_{X_1} \times P_{X_2}$ , and  $Y \in \mathcal{Y}$  the outcome of  $W$  on inputs  $X_1, X_2$ .

We will also consider what we call the sum success probability  $S_{\text{sum}}(W, k_1, k_2)$ , defined using  $\frac{\mathbb{P}(J_1=I_1) + \mathbb{P}(J_2=I_2)}{2}$  rather than  $\mathbb{P}(J_1 = I_1, J_2 = I_2)$  as an objective value, which leads

to the following optimization program:

$$\begin{aligned}
 S_{\text{sum}}(W, k_1, k_2) := & \underset{e_1, e_2, d_1, d_2}{\text{maximize}} \quad \frac{1}{2k_1k_2} \sum_{i_1, i_2, x_1, x_2, y} W(y|x_1x_2)e_1(x_1|i_1)e_2(x_2|i_2)d_1(i_1|y) \\
 & + \frac{1}{2k_1k_2} \sum_{i_1, i_2, x_1, x_2, y} W(y|x_1x_2)e_1(x_1|i_1)e_2(x_2|i_2)d_2(i_2|y) \\
 \text{subject to} & \quad \sum_{x_1 \in \mathcal{X}_1} e_1(x_1|i_1) = 1, \forall i_1 \in [k_1] \\
 & \quad \sum_{x_2 \in \mathcal{X}_2} e_2(x_2|i_2) = 1, \forall i_2 \in [k_2] \\
 & \quad \sum_{j_1 \in [k_1]} d_1(j_1|y) = 1, \forall y \in \mathcal{Y} \\
 & \quad \sum_{j_2 \in [k_2]} d_2(j_2|y) = 1, \forall y \in \mathcal{Y} \\
 & \quad e_1(x_1|i_1), e_2(x_2|i_2), d_1(j_1|y), d_2(j_2|y) \geq 0
 \end{aligned} \tag{4.3}$$

Note that we used independent decoders  $d_1(j_1|y), d_2(j_2|y)$  rather than a global  $d(j_1j_2|y)$  here. This does not change the value of the optimization program. Indeed, since the program is convex, an optimal solution can be found on the extremal points of the search space. Thus, if we had used the variable  $d(j_1j_2|y)$ , we could always take it to be a function  $d$  from  $\mathcal{Y}$  to  $[k_1] \times [k_2]$ . Taking  $d_1, d_2$  as the first and second coordinates of that function satisfies the equality  $d(j_1j_2|y) = d_1(j_1|y)d_2(j_2|y)$ , and therefore, the value of the program is the same in both cases. Note that it is also true for the program computing  $S(W, k_1, k_2)$ .

As for the usual (joint) success probability, we can define the sum-capacity region using Definition 2.12 by  $\mathcal{C}_{\text{sum}}(W) := \mathcal{C}[S_{\text{sum}}](W)$ . It turns out those two notions of success define the same capacity region:

**Proposition 4.2.**  $\mathcal{C}(W) = \mathcal{C}_{\text{sum}}(W)$

*Proof.* Let us focus on error probabilities rather than success ones. Call them respectively  $E(W, k_1, k_2) := 1 - S(W, k_1, k_2)$  and  $E_{\text{sum}}(W, k_1, k_2) := 1 - S_{\text{sum}}(W, k_1, k_2)$ . Let us fix a solution  $e_1, d_1, e_2, d_2$  of the optimization program computing  $S(W, k_1, k_2)$ . Let us remark first that:

$$\sum_{i_1, i_2, x_1, x_2, y} W(y|x_1x_2)e_1(x_1|i_1)e_2(x_2|i_2) = k_1k_2,$$

thus, the value of the maximum error for those encoders and decoders, which we call

$E(W, k_1, k_2, e_1, d_1, e_2, d_2)$ , is:

$$\begin{aligned}
 & 1 - \frac{1}{k_1 k_2} \sum_{i_1, i_2, x_1, x_2, y} W(y|x_1 x_2) e_1(x_1|i_1) e_2(x_2|i_2) d_1(i_1|y) d_2(i_2|y) \\
 &= \frac{1}{k_1 k_2} \sum_{i_1, i_2, x_1, x_2, y} W(y|x_1 x_2) e_1(x_1|i_1) e_2(x_2|i_2) \\
 & - \frac{1}{k_1 k_2} \sum_{i_1, i_2, x_1, x_2, y} W(y|x_1 x_2) e_1(x_1|i_1) e_2(x_2|i_2) d_1(i_1|y) d_2(i_2|y) \\
 &= \frac{1}{k_1 k_2} \sum_{i_1, i_2, x_1, x_2, y} W(y|x_1 x_2) e_1(x_1|i_1) e_2(x_2|i_2) [1 - d_1(i_1|y) d_2(i_2|y)] .
 \end{aligned} \tag{4.4}$$

Similarly, the value of the sum error for those encoder and decoders, which we call  $E_{\text{sum}}(W, k_1, k_2, e_1, d_1, e_2, d_2)$ , is:

$$\begin{aligned}
 & 1 - \frac{1}{k_1 k_2} \sum_{i_1, i_2, x_1, x_2, y} W(y|x_1 x_2) e_1(x_1|i_1) e_2(x_2|i_2) \frac{d_1(i_1|y) + d_2(i_2|y)}{2} \\
 &= \frac{1}{k_1 k_2} \sum_{i_1, i_2, x_1, x_2, y} W(y|x_1 x_2) e_1(x_1|i_1) e_2(x_2|i_2) \left[ 1 - \frac{d_1(i_1|y) + d_2(i_2|y)}{2} \right] .
 \end{aligned} \tag{4.5}$$

However, for  $x, y \in [0, 1]$ , we have that:

$$1 - xy \geq \max(1 - x, 1 - y) \geq 1 - \frac{x + y}{2} ,$$

and:

$$1 - xy \leq (1 - x) + (1 - y) = 2 \left( 1 - \frac{x + y}{2} \right) .$$

This means that, for all  $e_1, d_1, e_2, d_2$ , we have:

$$E_{\text{sum}}(W, k_1, k_2, e_1, d_1, e_2, d_2) \leq E(W, k_1, k_2, e_1, d_1, e_2, d_2) ,$$

and:

$$E(W, k_1, k_2, e_1, d_1, e_2, d_2) \leq 2E_{\text{sum}}(W, k_1, k_2, e_1, d_1, e_2, d_2) ,$$

so, maximizing over all  $e_1, d_1, e_2, d_2$ , we get:

$$E_{\text{sum}}(W, k_1, k_2) \leq E(W, k_1, k_2) \leq 2E_{\text{sum}}(W, k_1, k_2) .$$

Thus, up to a multiplicative factor 2, the error is the same. In particular, when one of those errors tends to zero, the other one tends to zero as well. This implies that the capacity regions are the same.  $\square$

#### 4.1.2 Non-Signaling Assisted Capacities

**Three-party non-signaling assistance** We now consider the case where the senders and the receiver are given non-signaling assistance. This resource, which is a theoretical but easier to manipulate generalization of quantum entanglement, can be characterized as

follows. A tripartite non-signaling box is described by a joint conditional probability distribution  $P(x_1x_2(j_1j_2)|i_1i_2y)$  such that the marginal from any two parties is independent of the removed party's input, i.e., we have:

$$\begin{aligned} \forall x_2, j_1, j_2, i_1, i_2, y, i'_1, \quad & \sum_{x_1} P(x_1x_2(j_1j_2)|i_1i_2y) = \sum_{x_1} P(x_1x_2(j_1j_2)|i'_1i_2y) , \\ \forall x_1, j_1, j_2, i_1, i_2, y, i'_2, \quad & \sum_{x_2} P(x_1x_2(j_1j_2)|i_1i_2y) = \sum_{x_2} P(x_1x_2(j_1j_2)|i_1i'_2y) , \quad (4.6) \\ \forall x_1, x_2, i_1, i_2, y, y', \quad & \sum_{j_1, j_2} P(x_1x_2(j_1j_2)|i_1i_2y) = \sum_{j_1, j_2} P(x_1x_2(j_1j_2)|i_1i_2y') . \end{aligned}$$

This implies that one can consider for example  $P(x_1x_2|i_1i_2)$  since it does not depend on  $y$ , or even  $P(x_1|i_1)$  since it does not depend on  $i_2, y$ . Then, in our coding scenario, when the senders and the receiver are given non-signaling assistance, it means that they share a tripartite non-signaling box, the behavior of which is described by  $P$ . In this case, the expression  $e_1(x_1|i_1)e_2(x_2|i_2)d(j_1j_2|y)$  in (4.1) is replaced by  $P(x_1x_2(j_1j_2)|i_1i_2y)$ , as depicted in Figure 4.2.

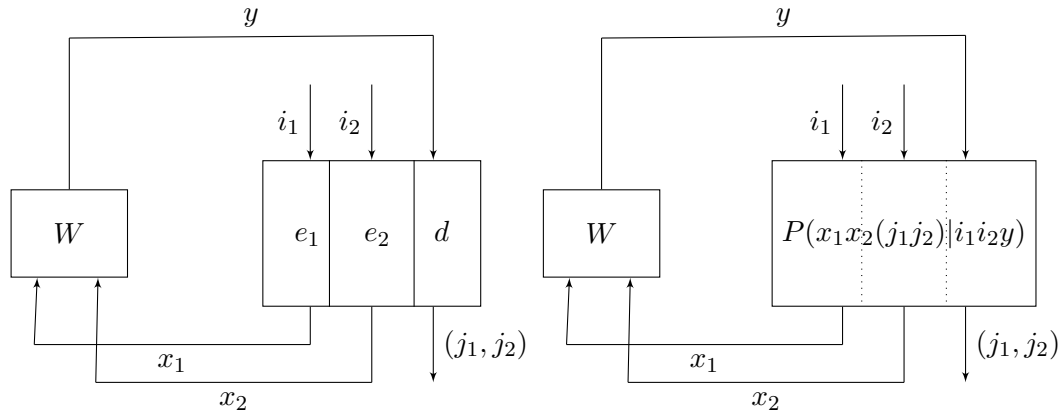

Figure 4.2 – A non-signaling box  $P$  replacing  $e_1, e_2$  and  $d$  in the coding problem for the MAC  $W$ .

The cyclicity of Figure 4.2 is at first sight counter-intuitive. Note first that  $P$  being a non-signaling box is completely independent of  $W$ : in particular, the variable  $y$  does not need to follow any law in the definition of  $P$  being a non-signaling box. Therefore, the remaining ambiguity is the apparent need to encode and decode at the same time. However, since  $P$  is a non-signaling box, we do not need to do both at the same time. Indeed,  $\forall y, P(x_1x_2|i_1i_2) = P(x_1x_2|i_1i_2y)$  by the non-signaling property of  $P$ . Thus, one can get the outputs  $x_1, x_2$  on inputs  $i_1, i_2$  without access to  $y$ , as that knowledge won't affect the laws of  $x_1, x_2$ . Then  $y$  follows the law given by  $W$  given those  $x_1, x_2$ . Finally, given access to  $y$ , the decoding process is described by:

$$P((j_1j_2)|i_1i_2yx_1x_2) = \frac{P(x_1x_2(j_1j_2)|i_1i_2y)}{P(x_1x_2|i_1i_2y)} = \frac{P(x_1x_2(j_1j_2)|i_1i_2y)}{P(x_1x_2|i_1i_2)}$$

so we recover globally  $P((j_1j_2)|i_1i_2yx_1x_2) \times P(x_1x_2|i_1i_2) = P(x_1x_2(j_1j_2)|i_1i_2y)$  the prescribed conditional probability. The non-signaling condition ensures that it is possible

to consider the conditional probabilities of each party independently. This clarifies how one can effectively encode and then decode messages through a non-signaling box.

As in the unassisted case, we want to maximize over all non-signaling boxes  $P$  the probability of successfully encoding and decoding the messages through  $W$ , i.e. the probability that  $j_1 = i_1$  and  $j_2 = i_2$ , given that the input messages are taken uniformly in  $[k_1]$  and  $[k_2]$ . We call this quantity  $S^{\text{NS}}(W, k_1, k_2)$ , which is characterized by the following optimization program:

$$\begin{aligned}
 S^{\text{NS}}(W, k_1, k_2) := & \underset{P}{\text{maximize}} && \frac{1}{k_1 k_2} \sum_{i_1, i_2, x_1, x_2, y} W(y|x_1 x_2) P(x_1 x_2(i_1 i_2)|i_1 i_2 y) \\
 & \text{subject to} && \sum_{x_1} P(x_1 x_2(j_1 j_2)|i_1 i_2 y) = \sum_{x_1} P(x_1 x_2(j_1 j_2)|i_1' i_2 y) \\
 & && \sum_{x_2} P(x_1 x_2(j_1 j_2)|i_1 i_2 y) = \sum_{x_2} P(x_1 x_2(j_1 j_2)|i_1 i_2 y') \\
 & && \sum_{j_1, j_2} P(x_1 x_2(j_1 j_2)|i_1 i_2 y) = \sum_{j_1, j_2} P(x_1 x_2(j_1 j_2)|i_1 i_2 y') \\
 & && \sum_{x_1, x_2, j_1, j_2} P(x_1 x_2(j_1 j_2)|i_1 i_2 y) = 1 \\
 & && P(x_1 x_2(j_1 j_2)|i_1 i_2 y) \geq 0
 \end{aligned} \tag{4.7}$$

Since it is given as a linear program, the complexity of computing  $S^{\text{NS}}(W, k_1, k_2)$  is polynomial in the number of variables and constraints (see for instance Section 7.1 of [GM07]), which is a polynomial in  $|\mathcal{X}_1|, |\mathcal{X}_2|, |\mathcal{Y}|, k_1$  and  $k_2$ . Also, as it is easy to check that a classical strategy is a particular case of a non-signaling assisted strategy, we have that  $S^{\text{NS}}(W, k_1, k_2) \geq S(W, k_1, k_2)$ .

As for the unassisted case, we define the non-signaling assisted capacity region using Definition 2.12 and  $S^{\text{NS}}$  by  $\mathcal{C}^{\text{NS}}(W) := \mathcal{C}[S^{\text{NS}}](W)$ , and its zero-error equivalent is defined by  $\mathcal{C}_0^{\text{NS}}(W) := \mathcal{C}_0[S^{\text{NS}}](W)$ .

**Independent non-signaling assistance** One can also consider the case where non-signaling assistance is shared independently between the first sender and the receiver as well as between the second encoder and the receiver, which we call independent non-signaling assistance. The precise scenario is depicted in Figure 4.3:



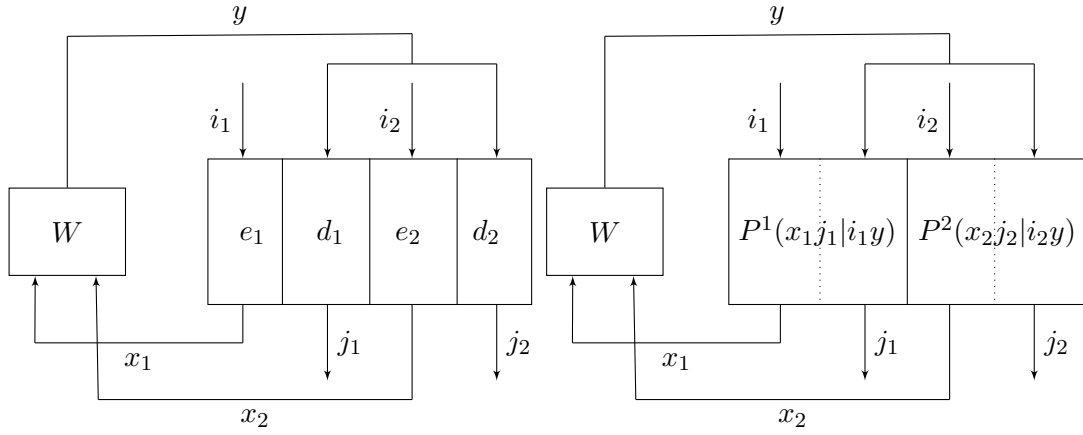

Figure 4.3 – Non-signaling boxes  $P^1, P^2$  replacing  $e_1, d_1$  and  $e_2, d_2$  in the coding problem for the MAC  $W$ .

This leads to the following definition of the success probability  $S^{\text{NS}_{\text{SR}}}(W, k_1, k_2)$ :

$$\begin{aligned}
 & \underset{P^1, P^2}{\text{maximize}} && \frac{1}{k_1 k_2} \sum_{i_1, i_2, x_1, x_2, y} W(y|x_1 x_2) P^1(x_1 i_1 | i_1 y) P^2(x_2 i_2 | i_2 y) \\
 & \text{subject to} && \sum_{x_1} P^1(x_1 j_1 | i_1 y) = \sum_{x_1} P^1(x_1 j_1 | i_1' y) \\
 & && \sum_{j_1} P^1(x_1 j_1 | i_1 y) = \sum_{j_1} P^1(x_1 j_1 | i_1' y) \\
 & && \sum_{x_1, j_1} P^1(x_1 j_1 | i_1 y) = 1 \\
 & && \sum_{x_2} P^2(x_2 j_2 | i_2 y) = \sum_{x_2} P^2(x_2 j_2 | i_2' y) \\
 & && \sum_{j_2} P^2(x_2 j_2 | i_2 y) = \sum_{j_2} P^2(x_2 j_2 | i_2' y) \\
 & && \sum_{x_2, j_2} P^2(x_2 j_2 | i_2 y) = 1 \\
 & && P^1(x_1 j_1 | i_1 y), P^2(x_2 j_2 | i_2 y) \geq 0
 \end{aligned} \tag{4.8}$$

As before, one can also consider the sum-success probability  $S_{\text{sum}}^{\text{NS}_{\text{SR}}}(W, k_1, k_2)$ :

$$\begin{aligned}
 & \underset{P^1, P^2}{\text{maximize}} \quad \frac{1}{2k_1 k_2} \sum_{i_1, i_2, x_1, x_2, y} W(y|x_1 x_2) P^1(x_1 i_1 | i_1 y) \sum_{j_2} P^2(x_2 j_2 | i_2 y) \\
 & \quad + \frac{1}{2k_1 k_2} \sum_{i_1, i_2, x_1, x_2, y} W(y|x_1 x_2) P^2(x_2 i_2 | i_2 y) \sum_{j_1} P^1(x_1 j_1 | i_1 y) \\
 & \text{subject to} \quad \sum_{x_1} P^1(x_1 j_1 | i_1 y) = \sum_{x_1} P^1(x_1 j_1 | i_1' y) \\
 & \quad \sum_{j_1} P^1(x_1 j_1 | i_1 y) = \sum_{j_1} P^1(x_1 j_1 | i_1' y) \\
 & \quad \sum_{x_1, j_1} P^1(x_1 j_1 | i_1 y) = 1 \\
 & \quad \sum_{x_2} P^2(x_2 j_2 | i_2 y) = \sum_{x_2} P^2(x_2 j_2 | i_2' y) \\
 & \quad \sum_{j_2} P^2(x_2 j_2 | i_2 y) = \sum_{j_2} P^2(x_2 j_2 | i_2' y) \\
 & \quad \sum_{x_2, j_2} P^2(x_2 j_2 | i_2 y) = 1 \\
 & \quad P^1(x_1 j_1 | i_1 y), P^2(x_2 j_2 | i_2 y) \geq 0
 \end{aligned} \tag{4.9}$$

We define the independent non-signaling assisted capacity (resp. sum-capacity) region using Definition 2.12 by  $\mathcal{C}^{\text{NS}_{\text{SR}}}(W) := \mathcal{C}[\text{S}^{\text{NS}_{\text{SR}}}] (W)$  (resp.  $\mathcal{C}_{\text{sum}}^{\text{NS}_{\text{SR}}}(W) := \mathcal{C}[\text{S}_{\text{sum}}^{\text{NS}_{\text{SR}}}] (W)$ ). It turns out those two notions of success define the same capacity region:

**Proposition 4.3.**  $\mathcal{C}^{\text{NS}_{\text{SR}}}(W) = \mathcal{C}_{\text{sum}}^{\text{NS}_{\text{SR}}}(W)$

*Proof.* Given non-signaling boxes  $P^1, P^2$ , the maximum success probability of encoding and decoding correctly with those is given by:

$$S^{\text{NS}_{\text{SR}}}(W, k_1, k_2, P^1, P^2) := \frac{1}{k_1 k_2} \sum_{i_1, i_2, x_1, x_2, y} W(y|x_1 x_2) P^1(x_1 i_1 | i_1 y) P^2(x_2 i_2 | i_2 y) .$$

This should be compared to the sum success probability of encoding and decoding correctly with those, which we call  $S_{\text{sum}}^{\text{NS}_{\text{SR}}}(W, k_1, k_2, P^1, P^2)$  and is equal to:

$$\begin{aligned}
 & \frac{1}{2k_1 k_2} \sum_{i_1, i_2, x_1, x_2, y} W(y|x_1 x_2) P^1(x_1 i_1 | i_1 y) \sum_{j_2} P^2(x_2 j_2 | i_2 y) \\
 & + \frac{1}{2k_1 k_2} \sum_{i_1, i_2, x_1, x_2, y} W(y|x_1 x_2) P^2(x_2 i_2 | i_2 y) \sum_{j_1} P^1(x_1 j_1 | i_1 y) .
 \end{aligned} \tag{4.10}$$

Similarly to what was done in Proposition 4.2, we focus on error probabilities rather than success probabilities. We have that:

$$\frac{1}{k_1 k_2} \sum_{i_1, i_2, x_1, x_2, y} W(y|x_1 x_2) \sum_{j_1, j_2} P^1(x_1 j_1 | i_1 y) P^2(x_2 j_2 | i_2 y) = 1 ,$$

so we get that  $E^{\text{NSSR}}(W, k_1, k_2, P^1, P^2)$  is equal to:

$$\begin{aligned}
 & \frac{1}{k_1 k_2} \sum_{i_1, i_2, x_1, x_2, y} W(y|x_1 x_2) \sum_{j_1, j_2} P^1(x_1 j_1 | i_1 y) P^2(x_2 j_2 | i_2 y) \\
 & - \frac{1}{k_1 k_2} \sum_{i_1, i_2, x_1, x_2, y} W(y|x_1 x_2) P^1(x_1 i_1 | i_1 y) P^2(x_2 i_2 | i_2 y) \\
 & = \sum_{i_1, i_2, x_1, x_2, y} W(y|x_1 x_2) \sum_{(j_1, j_2) \neq (i_1, i_2)} P^1(x_1 j_1 | i_1 y) P^2(x_2 j_2 | i_2 y).
 \end{aligned} \tag{4.11}$$

On the other hand, since:

$$\begin{aligned}
 & \sum_{j_1, j_2} P^1(x_1 j_1 | i_1 y) P^2(x_2 j_2 | i_2 y) - P^1(x_1 i_1 | i_1 y) \sum_{j_2} P^2(x_2 j_2 | i_2 y) \\
 & = \sum_{j_1 \neq i_1, j_2} P^1(x_1 j_1 | i_1 y) P^2(x_2 j_2 | i_2 y),
 \end{aligned} \tag{4.12}$$

and symmetrically, we get that  $E_{\text{sum}}^{\text{NSSR}}(W, k_1, k_2, P^1, P^2)$  is equal to:

$$\begin{aligned}
 & \frac{1}{2k_1 k_2} \sum_{i_1, i_2, x_1, x_2, y} W(y|x_1 x_2) \sum_{j_1 \neq i_1, j_2} P^1(x_1 j_1 | i_1 y) P^2(x_2 j_2 | i_2 y) \\
 & + \frac{1}{2k_1 k_2} \sum_{i_1, i_2, x_1, x_2, y} W(y|x_1 x_2) \sum_{j_1, j_2 \neq i_2} P^1(x_1 j_1 | i_1 y) P^2(x_2 j_2 | i_2 y) \\
 & = \frac{1}{k_1 k_2} \sum_{i_1, i_2, x_1, x_2, y} W(y|x_1 x_2) \sum_{j_1 \neq i_1, j_2 \neq i_2} P^1(x_1 j_1 | i_1 y) P^2(x_2 j_2 | i_2 y) \\
 & + \frac{1}{k_1 k_2} \sum_{i_1, i_2, x_1, x_2, y} W(y|x_1 x_2) \frac{\sum_{(j_1, j_2) \in S} P^1(x_1 j_1 | i_1 y) P^2(x_2 j_2 | i_2 y)}{2},
 \end{aligned} \tag{4.13}$$

with  $S := \{(j_1, i_2) : j_1 \in [k_1] - \{i_1\}\} \cup \{(i_1, j_2) : j_2 \in [k_2] - \{i_2\}\}$ . However, we have that:

$$\begin{aligned}
 & \sum_{j_1 \neq i_1, j_2 \neq i_2} P^1(x_1 j_1 | i_1 y) P^2(x_2 j_2 | i_2 y) + \frac{\sum_{(j_1, j_2) \in S} P^1(x_1 j_1 | i_1 y) P^2(x_2 j_2 | i_2 y)}{2} \\
 & \leq \sum_{j_1 \neq i_1, j_2 \neq i_2} P^1(x_1 j_1 | i_1 y) P^2(x_2 j_2 | i_2 y) + \sum_{(j_1, j_2) \in S} P^1(x_1 j_1 | i_1 y) P^2(x_2 j_2 | i_2 y) \\
 & = \sum_{(j_1, j_2) \neq (i_1, i_2)} P^1(x_1 j_1 | i_1 y) P^2(x_2 j_2 | i_2 y) \\
 & \leq 2 \left( \sum_{j_1 \neq i_1, j_2 \neq i_2} P^1(x_1 j_1 | i_1 y) P^2(x_2 j_2 | i_2 y) + \frac{\sum_{(j_1, j_2) \in S} P^1(x_1 j_1 | i_1 y) P^2(x_2 j_2 | i_2 y)}{2} \right).
 \end{aligned} \tag{4.14}$$

This implies that:

$$E_{\text{sum}}^{\text{NSSR}}(W, k_1, k_2, P^1, P^2) \leq E^{\text{NSSR}}(W, k_1, k_2, P^1, P^2) \leq 2E_{\text{sum}}^{\text{NSSR}}(W, k_1, k_2, P^1, P^2),$$

and by maximizing over all  $P^1$  and  $P^2$ :

$$E_{\text{sum}}^{\text{NSSR}}(W, k_1, k_2) \leq E^{\text{NSSR}}(W, k_1, k_2) \leq 2E_{\text{sum}}^{\text{NSSR}}(W, k_1, k_2).$$

Thus, as before, the capacity regions are the same.  $\square$

## 4.2 Hardness of Approximation for Multiple-Access Channel Coding

Since MACs are more general than point-to-point channels (by defining  $W(y|x_1x_2) := \hat{W}(y|x_1)$  for  $\hat{W}$  a point-to-point channel and looking only at its first input), computing  $S(W, k_1, k_2)$  is NP-hard, and it is even NP-hard to approximate within a better ratio than  $1 - e^{-1}$ , as a consequence of the hardness result for point-to-point channels from [BF18].

On the other hand, it has been shown in [LALS20] that it is NP-hard to decide whether a rate pair belongs to the classical capacity region of a MAC.

The goal of this section is to show that, under some reasonable hardness assumptions, the multiple-access channel coding problem cannot be approximated in polynomial time within a  $\Omega(1)$  factor. We will achieve this through a simple reduction from the bipartite version of the densest  $k$ -subgraph problem [FKP01], where one aims at finding a subgraph of  $k$  vertices with the highest number of edges. In the bipartite version, given a bipartite graph  $G = (A \sqcup B, E)$  and two parameters  $k_1$  and  $k_2$ , the goal is to find subsets  $S \subseteq A$  and  $T \subseteq B$  such that  $|S| = k_1, |T| = k_2$  with the maximum number of edges contained in  $S \cup T$ , i.e.  $|(S \times T) \cap E|$ . With a simple reduction from the maximum edge biclique problem [Pee03], the bipartite densest subgraph problem is NP-complete.

A well-known result by Alon et al. [AAM<sup>+</sup>11] shows that, under the following complexity hypothesis on random clauses with  $k$  literals ( $k$ -SAT formulas) introduced by Feige in [Fei02], there is no polynomial-time  $\Omega(1)$ -approximation algorithm for the bipartite densest subgraph problem; see [AAM<sup>+</sup>11] for further details.

**Hypothesis 4.1** ([Fei02]). *For some constant  $c > 0$ , for every  $k$ , for  $\Delta$  a sufficiently large constant independent of  $n$ , there is no polynomial-time algorithm that on most random  $k$ -SAT formulas with  $n$  variables and  $m = \Delta n$  clauses outputs **typical**, but never outputs **typical** on  $k$ -SAT formulas with at least  $m2^{-c\sqrt{k}}$  satisfiable clauses.*

We will consider the following reformulation of the multiple-access channel coding problem:

**Proposition 4.4.** *Given a MAC  $W$  and integers  $k_1, k_2$ , the multiple-access channel coding problem entails maximizing:*

$$f_W(S, T) := \frac{1}{|S||T|} \sum_{y \in \mathcal{Y}} \max_{x_1 \in S, x_2 \in T} W(y|x_1x_2),$$

over all sets  $S \subseteq \mathcal{X}_1, T \subseteq \mathcal{X}_2$  with  $|S| = k_1, |T| = k_2$ .

*Proof.* As the multiple-access channel coding problem is a convex program, its optimal solution can be found on integer solutions, i.e. when  $e_1, e_2$  and  $d$  are functions. Note that this restriction does not affect the hardness of the problem as a deterministic code with a better or equal value can be retrieved easily from any code.

Therefore, given encoders  $e_1, e_2$ , the objective value becomes:

$$\max_d \frac{1}{k_1 k_2} \sum_{i_1, i_2, y} W(y|e_1(i_1)e_2(i_2)) \mathbb{1}_{d(y)=(i_1, i_2)} = \frac{1}{k_1 k_2} \sum_y \max_{i_1, i_2} W(y|e_1(i_1)e_2(i_2)),$$

---

## 4.2. Hardness of Approximation for Multiple-Access Channel Coding

by taking  $d(y) \in \operatorname{argmax}_{i_1, i_2} \{W(y|e_1(i_1)e_2(i_2))\}$ . Finally, optimizing over functions  $e_1, e_2$  is the same as optimizing over sets  $S, T$  of size  $k_1, k_2$  (corresponding to their images). Thus, we have that the multiple-access channel coding can be reformulated as:

$$\max_{S \subseteq \mathcal{X}_1, T \subseteq \mathcal{X}_2: |S|=k_1, |T|=k_2} \frac{1}{|S||T|} \sum_{y \in \mathcal{Y}} \max_{x_1 \in S, x_2 \in T} W(y|x_1 x_2).$$

□

The previously mentioned hardness of approximation for the bipartite densest subgraph problem from [AAM<sup>+</sup>11] will imply the following hardness of approximation for the multiple-access channel coding problem:

**Theorem 4.5.** *Under Hypothesis 4.1, there is no polynomial-time  $\Omega(1)$ -approximation algorithm for the multiple-access channel coding problem.*

*Proof.* Given a bipartite graph  $G = (A \sqcup B, E)$ , we define its associated MAC  $W_G$  on  $\mathcal{X}_1 := A, \mathcal{X}_2 := B$  and  $\mathcal{Y} := A \times B$  in the following way:

$$W((a', b')|ab) = \begin{cases} \mathbb{1}_{a=a'} \mathbb{1}_{b=b'} & \text{if } (a, b) \in E, \\ \frac{1}{|A||B|} & \text{otherwise.} \end{cases} \quad (4.15)$$

It is indeed a MAC as  $\sum_{a', b'} W((a', b')|ab) = \sum_{a', b'} \mathbb{1}_{a=a'} \mathbb{1}_{b=b'} = 1$  if  $(a, b) \in E$  and  $\sum_{a', b'} W((a', b')|ab) = \sum_{a', b'} \frac{1}{|A||B|} = 1$  otherwise.

We claim the following linear relation between the objective functions of the bipartite densest subgraph problem on  $G$  and the multiple-access channel coding problem on  $W_G$ :

**Lemma 4.6.** *For  $G = (A \sqcup B, E)$ ,  $S \subseteq A$  and  $T \subseteq B$ :*

$$\frac{f_{W_G}(S, T) - \frac{1}{|S||T|}}{1 - \frac{1}{|A||B|}} = \frac{|(S \times T) \cap E|}{|S||T|}.$$

*Proof of Lemma 4.6.* We have that:

$$\begin{aligned} f_{W_G}(S, T) &= \frac{1}{|S||T|} \sum_{a' \in S, b' \in T} \max_{a \in S, b \in T} W((a', b')|ab) \\ &= \frac{1}{|S||T|} \left( \sum_{(a', b') \in (S \times T) \cap E} \max_{a \in S, b \in T} W((a', b')|ab) + \sum_{(a', b') \notin (S \times T) \cap E} \max_{a \in S, b \in T} W((a', b')|ab) \right) \\ &= \frac{1}{|S||T|} \left( \sum_{(a', b') \in (S \times T) \cap E} 1 + \sum_{(a', b') \notin (S \times T) \cap E} \frac{1}{|A||B|} \right) \\ &= \frac{1}{|S||T|} \left( |(S \times T) \cap E| + \frac{|A||B| - |(S \times T) \cap E|}{|A||B|} \right) \\ &= \frac{1}{|S||T|} + \frac{|(S \times T) \cap E|}{|S||T|} \left( 1 - \frac{1}{|A||B|} \right), \end{aligned} \quad (4.16)$$

which implies the claimed equality. □

Let us now assume that a polynomial-time constant approximation of the multiple-access channel coding problem exists. Let us call  $\lambda \in (0, 1)$  the ratio of that algorithm. Then, for any  $G = (A \sqcup B, E)$ ,  $k_1, k_2$ , we can apply our algorithm to  $W_G, k_1, k_2$  and get  $S_{\text{approx}}, T_{\text{approx}}$  of size  $k_1, k_2$  such that:

$$f_{W_G}(S_{\text{approx}}, T_{\text{approx}}) \geq \lambda \cdot \max_{S, T: |S|=k_1, |T|=k_2} f_{W_G}(S, T).$$

But, thanks to Lemma 4.6, we have that:

$$\frac{\max_{S, T: |S|=k_1, |T|=k_2} f_{W_G}(S, T) - \frac{1}{k_1 k_2}}{1 - \frac{1}{|A||B|}} = \frac{\max_{S, T: |S|=k_1, |T|=k_2} |(S \times T) \cap E|}{k_1 k_2}.$$

So in all, we have:

$$\begin{aligned} \frac{|(S_{\text{approx}} \times T_{\text{approx}}) \cap E|}{k_1 k_2} &= \frac{f_{W_G}(S_{\text{approx}}, T_{\text{approx}}) - \frac{1}{k_1 k_2}}{1 - \frac{1}{|A||B|}} \\ &\geq \frac{\lambda \cdot \max_{S, T: |S|=k_1, |T|=k_2} f_{W_G}(S, T) - \frac{1}{k_1 k_2}}{1 - \frac{1}{|A||B|}} \\ &= \lambda \cdot \frac{\max_{S, T: |S|=k_1, |T|=k_2} f_{W_G}(S, T) - \frac{1}{k_1 k_2}}{1 - \frac{1}{|A||B|}} - \frac{\frac{1-\lambda}{k_1 k_2}}{1 - \frac{1}{|A||B|}} \\ &= \lambda \cdot \frac{\max_{S, T: |S|=k_1, |T|=k_2} |(S \times T) \cap E|}{k_1 k_2} - \frac{\frac{1-\lambda}{k_1 k_2}}{1 - \frac{1}{|A||B|}}, \end{aligned} \tag{4.17}$$

and thus:

$$|(S_{\text{approx}} \times T_{\text{approx}}) \cap E| \geq \lambda \cdot \max_{S, T: |S|=k_1, |T|=k_2} |(S \times T) \cap E| - \frac{1-\lambda}{1 - \frac{1}{|A||B|}}.$$

Let us consider instances of the bipartite densest subgraph problem with  $|E| \geq \min(k_1, k_2)$ , which implies directly that  $\max_{S, T: |S|=k_1, |T|=k_2} |(S \times T) \cap E| \geq \min(k_1, k_2)$  by picking  $\min(k_1, k_2)$  edges and taking their endpoints to construct  $S$  and  $T$ . As  $|A||B| \geq 2$ , we have that  $\frac{1-\lambda}{1 - \frac{1}{|A||B|}} \leq 2$ . Then:

$$\begin{aligned} |(S_{\text{approx}} \times T_{\text{approx}}) \cap E| &\geq \lambda \cdot \max_{S, T: |S|=k_1, |T|=k_2} |(S \times T) \cap E| - 2 \\ &\geq (1-c)\lambda \cdot \max_{S, T: |S|=k_1, |T|=k_2} |(S \times T) \cap E| + c\lambda \min(k_1, k_2) - 2 \text{ for any } c \in (0, 1) \\ &= \left(1 - \frac{2}{\lambda \min(k_1, k_2)}\right) \lambda \cdot \max_{S, T: |S|=k_1, |T|=k_2} |(S \times T) \cap E|, \end{aligned} \tag{4.18}$$

by choosing  $c = \frac{2}{\lambda \min(k_1, k_2)}$ . Finally, for instances such that  $k_1, k_2 \geq \frac{4}{\lambda}$ , we have that:

$$|(S_{\text{approx}} \times T_{\text{approx}}) \cap E| \geq \frac{\lambda}{2} \cdot \max_{S, T: |S|=k_1, |T|=k_2} |(S \times T) \cap E|.$$

Therefore, if a polynomial-time approximation of the multiple-access channel coding problem of constant ratio  $\lambda$  exists, then we have a polynomial-time  $\frac{\lambda}{2}$ -approximation of

the bipartite densest subgraph problem for instances satisfying  $|E| \geq \min(k_1, k_2)$  and  $k_1, k_2 \geq \frac{4}{\lambda}$ . Note that the bipartite densest subgraph problem can be solved in polynomial time for instances which do not satisfy these constraints (as  $\frac{1}{\lambda}$  is constant). Thus, we have in all a constant polynomial-time approximation for the bipartite densest subgraph problem, which is in contradiction with Hypothesis 4.1 as proved in [AAM<sup>+</sup>11]. Hence, under Hypothesis 4.1, there is no polynomial-time  $\Omega(1)$ -approximation algorithm for the multiple-access channel coding problem.  $\square$

### 4.3 Properties of Non-Signaling Assisted Codes

#### 4.3.1 Symmetrization

One can prove an equivalent formulation of the linear program computing  $S^{\text{NS}}(W, k_1, k_2)$  with a number of variables and constraints polynomial in only  $|\mathcal{X}_1|, |\mathcal{X}_2|$  and  $|\mathcal{Y}|$  and independent of  $k_1$  and  $k_2$ :

**Proposition 4.7.** *For a MAC  $W : \mathcal{X}_1 \times \mathcal{X}_2 \rightarrow \mathcal{Y}$  and  $k_1, k_2 \in \mathbb{N}^*$ , we have:*

$$\begin{aligned}
 S^{\text{NS}}(W, k_1, k_2) = & \underset{r, r^1, r^2, p}{\text{maximize}} \quad \frac{1}{k_1 k_2} \sum_{x_1, x_2, y} W(y|x_1 x_2) r_{x_1, x_2, y} \\
 & \text{subject to} \quad \sum_{x_1, x_2} r_{x_1, x_2, y} = 1 \\
 & \quad \sum_{x_1} r_{x_1, x_2, y}^1 = k_1 \sum_{x_1} r_{x_1, x_2, y} \\
 & \quad \sum_{x_2} r_{x_1, x_2, y}^2 = k_2 \sum_{x_2} r_{x_1, x_2, y} \\
 & \quad \sum_{x_1} p_{x_1, x_2} = k_1 \sum_{x_1} r_{x_1, x_2, y}^2 \\
 & \quad \sum_{x_2} p_{x_1, x_2} = k_2 \sum_{x_2} r_{x_1, x_2, y}^1 \\
 & \quad 0 \leq r_{x_1, x_2, y} \leq r_{x_1, x_2, y}^1, r_{x_1, x_2, y}^2 \leq p_{x_1, x_2} \\
 & \quad p_{x_1, x_2} - r_{x_1, x_2, y}^1 - r_{x_1, x_2, y}^2 + r_{x_1, x_2, y} \geq 0
 \end{aligned} \tag{4.19}$$

*Proof.* One can check that given a solution of the original program, the following choice of variables is a valid solution of the second program achieving the same objective value:

$$\begin{aligned}
 r_{x_1, x_2, y} &:= \sum_{i_1, i_2} P(x_1 x_2(i_1 i_2) | i_1 i_2 y), & r_{x_1, x_2, y}^1 &:= \sum_{j_1, i_1, i_2} P(x_1 x_2(j_1 i_2) | i_1 i_2 y), \\
 r_{x_1, x_2, y}^2 &:= \sum_{j_2, i_1, i_2} P(x_1 x_2(i_1 j_2) | i_1 i_2 y), & p_{x_1, x_2} &:= \sum_{j_1, j_2, i_1, i_2} P(x_1 x_2(j_1 j_2) | i_1 i_2 y).
 \end{aligned} \tag{4.20}$$

Note that  $p_{x_1, x_2}$  is well-defined since  $\sum_{j_1, j_2, i_1, i_2} P(x_1 x_2(j_1 j_2) | i_1 i_2 y)$  is independent of  $y$  as  $P$  is a non-signaling box.

For the other direction, given those variables, a non-signaling probability distribution  $P(x_1 x_2(j_1 j_2) | i_1 i_2 y)$  achieving the same objective value is given by, for  $j_1 \neq i_1$  and

$j_2 \neq i_2$ :

$$\begin{aligned}
 P(x_1x_2(i_1i_2)|i_1i_2y) &:= \frac{r_{x_1,x_2,y}}{k_1k_2}, \\
 P(x_1x_2(j_1i_2)|i_1i_2y) &:= \frac{r_{x_1,x_2,y}^1 - r_{x_1,x_2,y}}{k_1k_2(k_1 - 1)}, \\
 P(x_1x_2(i_1j_2)|i_1i_2y) &:= \frac{r_{x_1,x_2,y}^2 - r_{x_1,x_2,y}}{k_1k_2(k_2 - 1)}, \\
 P(x_1x_2(j_1j_2)|i_1i_2y) &:= \frac{p_{x_1,x_2} - r_{x_1,x_2,y}^1 - r_{x_1,x_2,y}^2 + r_{x_1,x_2,y}}{k_1k_2(k_1 - 1)(k_2 - 1)}.
 \end{aligned} \tag{4.21}$$

□

This symmetrization can also be done for the program computing  $S_{\text{sum}}^{\text{NSSR}}(W, k_1, k_2)$ :

**Proposition 4.8.**

$$\begin{aligned}
 S_{\text{sum}}^{\text{NSSR}}(W, k_1, k_2) &= \underset{r^1, r^2, p^1, p^2}{\text{maximize}} \quad \frac{1}{2k_1k_2} \sum_{x_1, x_2, y} W(y|x_1x_2) (p_{x_2}^2 r_{x_1,y}^1 + p_{x_1}^1 r_{x_2,y}^2) \\
 &= \frac{1}{2k_1} \sum_{x_1, y} W_{p^2, k_2}^1(y|x_1) r_{x_1,y}^1 + \frac{1}{2k_2} \sum_{x_2, y} W_{p^1, k_1}^2(y|x_2) r_{x_2,y}^2 \\
 &\text{with } W_{p^2, k_2}^1(y|x_1) := \frac{1}{k_2} \sum_{x_2} W(y|x_1x_2) p_{x_2}^2 \\
 &\text{and } W_{p^1, k_1}^2(y|x_2) := \frac{1}{k_1} \sum_{x_1} W(y|x_1x_2) p_{x_1}^1 \\
 &\text{subject to } \sum_{x_1} r_{x_1,y}^1 = 1, \sum_{x_2} r_{x_2,y}^2 = 1 \\
 &\quad \sum_{x_1} p_{x_1}^1 = k_1, \sum_{x_2} p_{x_2}^2 = k_2 \\
 &\quad 0 \leq r_{x_1,y}^1 \leq p_{x_1}^1, 0 \leq r_{x_2,y}^2 \leq p_{x_2}^2
 \end{aligned} \tag{4.22}$$

*Proof.* One can check that given a solution of the original program, the following choice of variables is a valid solution of the second program achieving the same objective value:

$$\begin{aligned}
 r_{x_1,y}^1 &:= \sum_{i_1} P^1(x_1i_1|i_1y), \quad p_{x_1}^1 := \sum_{j_1, i_1} P^1(x_1j_1|i_1y), \\
 r_{x_2,y}^2 &:= \sum_{i_2} P^2(x_2i_2|i_2y), \quad p_{x_2}^2 := \sum_{j_2, i_2} P^2(x_2j_2|i_2y).
 \end{aligned} \tag{4.23}$$

Note that  $p_{x_1}^1$  and  $p_{x_2}^2$  are well-defined since  $\sum_{j_1, i_1} P^1(x_1j_1|i_1y)$  and  $\sum_{j_2, i_2} P^2(x_2j_2|i_2y)$  are independent of  $y$  as  $P^1$  and  $P^2$  are non-signaling boxes.

For the other direction, given those variables, non-signaling probability distributions  $P^1(x_1j_1|i_1y)$  and  $P^2(x_2j_2|i_2y)$  achieving the same objective value are given by, for  $j_1 \neq i_1$



and  $j_2 \neq i_2$ :

$$\begin{aligned}
 P^1(x_1 i_1 | i_1 y) &:= \frac{r_{x_1, y}^1}{k_1}, \\
 P^1(x_1 j_1 | i_1 y) &:= \frac{p_{x_1, y}^1 - r_{x_1, y}^1}{k_1(k_1 - 1)}, \\
 P^2(x_2 i_2 | i_2 y) &:= \frac{r_{x_2, y}^2}{k_2}, \\
 P^2(x_2 j_2 | i_2 y) &:= \frac{p_{x_2, y}^2 - r_{x_2, y}^2}{k_2(k_2 - 1)}.
 \end{aligned} \tag{4.24}$$

□

### 4.3.2 Properties of $S^{\text{NS}}(W, k_1, k_2)$ , $C^{\text{NS}}(W)$ and $C_0^{\text{NS}}(W)$

**Proposition 4.9.** *For a MAC  $W : \mathcal{X}_1 \times \mathcal{X}_2 \rightarrow \mathcal{Y}$  and  $k_1, k_2 \in \mathbb{N}^*$ , we have:*

1.  $\frac{1}{k_1 k_2} \leq S^{\text{NS}}(W, k_1, k_2) \leq 1$ .
2.  $S^{\text{NS}}(W, k_1, k_2) \leq \min\left(\frac{|\mathcal{X}_1|}{k_1}, \frac{|\mathcal{X}_2|}{k_2}, \frac{|\mathcal{Y}|}{k_1 k_2}\right)$ .
3. If  $k'_1 \leq k_1$  and  $k'_2 \leq k_2$ , then  $S^{\text{NS}}(W, k'_1, k'_2) \geq S^{\text{NS}}(W, k_1, k_2)$ .
4. For  $W' : \mathcal{X}'_1 \times \mathcal{X}'_2 \rightarrow \mathcal{Y}'$  and  $k_1, k_2 \in \mathbb{N}^*$ , we have  $S^{\text{NS}}(W \otimes W', k_1 k'_1, k_2 k'_2) \geq S^{\text{NS}}(W, k_1, k_2) \cdot S^{\text{NS}}(W', k'_1, k'_2)$ . In particular, for any positive integer  $n$ , we have  $S^{\text{NS}}(W^{\otimes n}, k_1^n, k_2^n) \geq [S^{\text{NS}}(W, k_1, k_2)]^n$  and  $S^{\text{NS}}(W \otimes W', k_1, k_2) \geq S^{\text{NS}}(W, k_1, k_2)$ .

*Proof.* 1. We will start by proving that  $S^{\text{NS}}(W, k_1, k_2) \geq \frac{1}{k_1 k_2}$ . Take  $p_{x_1, x_2} := \frac{k_1 k_2}{|\mathcal{X}_1| |\mathcal{X}_2|}$ ,  $r_{x_1, x_2, y}^1 := \frac{p_{x_1, x_2}}{k_2}$ ,  $r_{x_1, x_2, y}^2 := \frac{p_{x_1, x_2}}{k_1}$  and  $r_{x_1, x_2, y} := \frac{p_{x_1, x_2}}{k_1 k_2} = \frac{1}{|\mathcal{X}_1| |\mathcal{X}_2|}$ . One can easily check that it is indeed a valid solution of the linear program computing  $S^{\text{NS}}(W, k_1, k_2)$ . Thus we have:

$$\begin{aligned}
 S^{\text{NS}}(W, k_1, k_2) &\geq \frac{1}{k_1 k_2} \sum_{x_1, x_2, y} W(y | x_1 x_2) r_{x_1, x_2, y} \\
 &= \frac{1}{k_1 k_2} \sum_{x_1, x_2} \frac{1}{|\mathcal{X}_1| |\mathcal{X}_2|} \sum_y W(y | x_1 x_2) \\
 &= \frac{1}{k_1 k_2} \sum_{x_1, x_2} \frac{1}{|\mathcal{X}_1| |\mathcal{X}_2|} = \frac{1}{k_1 k_2}.
 \end{aligned} \tag{4.25}$$

Furthermore, in order to show that it is at most 1, let us consider an optimal solution of  $S^{\text{NS}}(W, k_1, k_2)$ . We have:

$$\begin{aligned}
 S^{\text{NS}}(W, k_1, k_2) &= \frac{1}{k_1 k_2} \sum_{x_1, x_2, y} W(y | x_1 x_2) r_{x_1, x_2, y} \leq \frac{1}{k_1 k_2} \sum_{x_1, x_2, y} W(y | x_1 x_2) p_{x_1, x_2} \\
 &= \frac{1}{k_1 k_2} \sum_{x_1, x_2} p_{x_1, x_2} \sum_y W(y | x_1 x_2) = \frac{1}{k_1 k_2} \sum_{x_1, x_2} p_{x_1, x_2} = 1,
 \end{aligned} \tag{4.26}$$

since  $\sum_{x_1, x_2} p_{x_1, x_2} = k_1 \sum_{x_1, x_2} r_{x_1, x_2, y}^2 = k_1 k_2 \sum_{x_1, x_2} r_{x_1, x_2, y} = k_1 k_2$ .

2. First let us show that  $S^{\text{NS}}(W, k_1, k_2) \leq \frac{|\mathcal{X}_1|}{k_1}$  (the case  $S^{\text{NS}}(W, k_1, k_2) \leq \frac{|\mathcal{X}_2|}{k_2}$  is symmetric):

$$\begin{aligned}
 S^{\text{NS}}(W, k_1, k_2) &= \frac{1}{k_1 k_2} \sum_{x_1, x_2, y} W(y|x_1 x_2) r_{x_1, x_2, y} \\
 &\leq \frac{1}{k_1 k_2} \sum_{x_1, x_2, y} W(y|x_1 x_2) r_{x_1, x_2, y}^2 \\
 &\leq \frac{1}{k_1 k_2} \sum_{x_2, y} \left( \sum_{x'_1} W(y|x'_1 x_2) \right) \cdot \left( \sum_{x_1} r_{x_1, x_2, y}^2 \right) \\
 &= \frac{1}{k_1 k_2} \sum_{x_2, y} \left( \sum_{x'_1} W(y|x'_1 x_2) \right) \cdot \left( \frac{1}{k_1} \sum_{x_1} p_{x_1, x_2} \right) \\
 &= \frac{1}{k_1^2 k_2} \sum_{x_1, x_2} p_{x_1, x_2} \sum_{x'_1} \left( \sum_y W(y|x'_1 x_2) \right) \\
 &= \frac{|\mathcal{X}_1|}{k_1^2 k_2} \sum_{x_1, x_2} p_{x_1, x_2} = \frac{|\mathcal{X}_1|}{k_1}.
 \end{aligned} \tag{4.27}$$

Let us show now that  $S^{\text{NS}}(W, k_1, k_2) \leq \frac{|\mathcal{Y}|}{k_1 k_2}$ :

$$\begin{aligned}
 S^{\text{NS}}(W, k_1, k_2) &= \frac{1}{k_1 k_2} \sum_{x_1, x_2, y} W(y|x_1 x_2) r_{x_1, x_2, y} \\
 &\leq \frac{1}{k_1 k_2} \sum_y \left( \max_{x_1, x_2} W(y|x_1 x_2) \right) \sum_{x_1, x_2} r_{x_1, x_2, y} \\
 &\leq \frac{1}{k_1 k_2} \sum_y \sum_{x_1, x_2} r_{x_1, x_2, y} = \frac{|\mathcal{Y}|}{k_1 k_2}.
 \end{aligned} \tag{4.28}$$

3. Let us assume that  $k'_1 \leq k_1$  and that  $k'_2 = k_2$ , since this latter case will follow by symmetry. Consider an optimal solution of  $S^{\text{NS}}(W, k_1, k_2) = \frac{1}{k_1} \sum_{i_1 \in [k_1]} f(i_1)$  with:

$$f(i_1) := \frac{1}{k_2} \sum_{x_1, x_2, y, i_2} W(y|x_1 x_2) P(x_1 x_2(i_1 i_2)|i_1 i_2 y),$$

and  $P$  non-signaling. Let us consider  $S \in \operatorname{argmax}_{S' \subseteq [k_1]: |S'|=k'_1} \sum_{i_1 \in S'} f(i_1)$ . Then, by construction, we have that  $\frac{1}{k'_1} \sum_{i_1 \in S} f(i_1) \geq \frac{1}{k_1} \sum_{i_1 \in [k_1]} f(i_1) = S^{\text{NS}}(W, k_1, k_2)$ , since we have taken the average of the  $k'_1$  largest values of the sum.

Let us define the strategy  $P'$  on the smallest set  $\mathcal{X}_1 \times \mathcal{X}_2 \times (S \times [k_2]) \times S \times [k_2] \times \mathcal{Y}$ :

$$\begin{aligned}
 P'(x_1 x_2(j_1 j_2)|i_1 i_2 y) &:= P(x_1 x_2(j_1 j_2)|i_1 i_2 y) + C(x_1 x_2 j_2|i_1 i_2 y), \\
 \text{with } C(x_1 x_2 j_2|i_1 i_2 y) &:= \frac{1}{k'_1} \sum_{j'_1 \in [k_1] - S} P(x_1 x_2(j'_1 j_2)|i_1 i_2 y).
 \end{aligned} \tag{4.29}$$

$P'$  is a correct conditional probability distribution. Indeed, it is nonnegative by construction, and we have that  $\sum_{x_1, x_2, j_1 \in S, j_2} P'(x_1 x_2(j_1 j_2) | i_1 i_2 y)$  is equal to:

$$\begin{aligned}
 & \sum_{x_1, x_2, j_1 \in S, j_2} P(x_1 x_2(j_1 j_2) | i_1 i_2 y) + \sum_{x_1, x_2, j_1 \in S, j_2} C(x_1 x_2 j_2 | i_1 i_2 y) \\
 &= \sum_{x_1, x_2, j_2} \sum_{j_1 \in S} P(x_1 x_2(j_1 j_2) | i_1 i_2 y) + \sum_{x_1, x_2, j_2} \sum_{j_1 \in S} \frac{1}{k'_1} \sum_{j'_1 \in [k_1] - S} P(x_1 x_2(j'_1 j_2) | i_1 i_2 y) \\
 &= \sum_{x_1, x_2, j_2} \sum_{j_1 \in S} P(x_1 x_2(j_1 j_2) | i_1 i_2 y) + \sum_{x_1, x_2, j_2} \sum_{j'_1 \in [k_1] - S} P(x_1 x_2(j'_1 j_2) | i_1 i_2 y) \\
 &= \sum_{x_1, x_2, j_1, j_2} P(x_1 x_2(j_1 j_2) | i_1 i_2 y) = 1.
 \end{aligned} \tag{4.30}$$

Let us show that  $P'$  is non-signaling:

a) First with  $x_1$ :

$$\begin{aligned}
 \sum_{x_1} P'(x_1 x_2(j_1 j_2) | i_1 i_2 y) &= \sum_{x_1} P(x_1 x_2(j_1 j_2) | i_1 i_2 y) + \sum_{x_1} C(x_1 x_2 j_2 | i_1 i_2 y) \\
 &= \sum_{x_1} P(x_1 x_2(j_1 j_2) | i_1 i_2 y) + \frac{1}{k'_1} \sum_{j'_1 \in [k_1] - S} \sum_{x_1} P(x_1 x_2(j'_1 j_2) | i_1 i_2 y) \\
 &= \sum_{x_1} P(x_1 x_2(j_1 j_2) | i'_1 i_2 y) + \frac{1}{k'_1} \sum_{j'_1 \in [k_1] - S} \sum_{x_1} P(x_1 x_2(j'_1 j_2) | i'_1 i_2 y)
 \end{aligned}$$

since  $P$  is non-signaling,

$$\sum_{x_1} P'(x_1 x_2(j_1 j_2) | i'_1 i_2 y) . \tag{4.31}$$

b) Then with  $x_2$ :

$$\begin{aligned}
 \sum_{x_2} P'(x_1 x_2(j_1 j_2) | i_1 i_2 y) &= \sum_{x_2} P(x_1 x_2(j_1 j_2) | i_1 i_2 y) + \sum_{x_2} C(x_1 x_2 j_2 | i_1 i_2 y) \\
 &= \sum_{x_2} P(x_1 x_2(j_1 j_2) | i_1 i_2 y) + \frac{1}{k'_1} \sum_{j'_1 \in [k_1] - S} \sum_{x_2} P(x_1 x_2(j'_1 j_2) | i_1 i_2 y) \\
 &= \sum_{x_2} P(x_1 x_2(j_1 j_2) | i_1 i'_2 y) + \frac{1}{k'_1} \sum_{j'_1 \in [k_1] - S} \sum_{x_2} P(x_1 x_2(j'_1 j_2) | i_1 i'_2 y)
 \end{aligned}$$

since  $P$  is non-signaling,

$$\sum_{x_2} P'(x_1 x_2(j_1 j_2) | i_1 i'_2 y) . \tag{4.32}$$

c) Finally with  $(j_1 j_2)$ , we have that  $\sum_{j_1 \in S, j_2} P'(x_1 x_2(j_1 j_2) | i_1 i_2 y)$  is equal to:

$$\begin{aligned}
 & \sum_{j_2} \sum_{j_1 \in S} P(x_1 x_2(j_1 j_2) | i_1 i_2 y) + \sum_{j_2} \sum_{j_1 \in S} C(x_1 x_2 j_2 | i_1 i_2 y) \\
 &= \sum_{j_2} \sum_{j_1 \in S} P(x_1 x_2(j_1 j_2) | i_1 i_2 y) + \sum_{j_2} \sum_{j_1 \in S} \frac{1}{k'_1} \sum_{j'_1 \in [k_1] - S} P(x_1 x_2(j'_1 j_2) | i_1 i_2 y) \\
 &= \sum_{j_2} \sum_{j_1 \in S} P(x_1 x_2(j_1 j_2) | i_1 i_2 y) + \sum_{j_2} \sum_{j'_1 \in [k_1] - S} P(x_1 x_2(j'_1 j_2) | i_1 i_2 y) \\
 &= \sum_{j_1, j_2} P(x_1 x_2(j_1 j_2) | i_1 i_2 y) \\
 &= \sum_{j_1, j_2} P(x_1 x_2(j_1 j_2) | i_1 i_2 y') \text{ since } P \text{ is non-signaling.} \\
 &= \sum_{j_1 \in S, j_2} P'(x_1 x_2(j_1 j_2) | i_1 i_2 y').
 \end{aligned} \tag{4.33}$$

Thus  $P'$  is a correct solution of the program computing  $S^{\text{NS}}(W, k'_1, k_2)$ , and it leads to the value:

$$\begin{aligned}
 S^{\text{NS}}(W, k'_1, k_2) &\geq \frac{1}{k'_1 k_2} \sum_{x_1, x_2, y, i_1 \in S, i_2} W(y | x_1 x_2) P'(x_1 x_2(i_1 i_2) | i_1 i_2 y) \\
 &\geq \frac{1}{k'_1 k_2} \sum_{x_1, x_2, y, i_1 \in S, i_2} W(y | x_1 x_2) P(x_1 x_2(i_1 i_2) | i_1 i_2 y) \tag{4.34} \\
 &= \frac{1}{k'_1} \sum_{i_1 \in S} f(i_1) \geq \frac{1}{k_1} \sum_{i_1 \in [k_1]} f(i_1) = S^{\text{NS}}(W, k_1, k_2).
 \end{aligned}$$

4. Consider optimal non-signaling probability distributions  $P$  and  $P'$  reaching respectively the values  $S^{\text{NS}}(W, k_1, k_2)$  and  $S^{\text{NS}}(W', k'_1, k'_2)$ . Then by Proposition 2.11,  $P \otimes P'$  is a non-signaling probability distribution on  $(\mathcal{X}_1 \times \mathcal{X}'_1) \times (\mathcal{X}_2 \times \mathcal{X}'_2) \times (([k_1] \times [k'_1]) \times ([k_2] \times [k'_2])) \times ([k_1] \times [k'_1]) \times ([k_2] \times [k'_2]) \times (\mathcal{Y} \times \mathcal{Y}')$ , which is trivially in bijection with  $(\mathcal{X}_1 \times \mathcal{X}'_1) \times (\mathcal{X}_2 \times \mathcal{X}'_2) \times ([k_1 k'_1] \times [k_2 k'_2]) \times [k_1 k'_1] \times [k_2 k'_2] \times (\mathcal{Y} \times \mathcal{Y}')$ . This will be a feasible solution of the program computing  $S^{\text{NS}}(W \otimes W', k_1 k'_1, k_2 k'_2)$ . Thus, we get that  $S^{\text{NS}}(W \otimes W', k_1 k'_1, k_2 k'_2)$  is larger than or equal to (where the first sums are over all indices  $x_1 x'_1, x_2 x'_2, yy', i_1 i'_1, i_2 i'_2$ ):

$$\begin{aligned}
 & \sum (W \otimes W') (yy' | x_1 x'_1 x_2 x'_2) (P \otimes P') (x_1 x'_1 x_2 x'_2 (i_1 i'_1 i_2 i'_2) | i_1 i'_1, i_2 i'_2 yy') \\
 &= \sum (W(y | x_1 x_2) \cdot W'(y' | x'_1 x'_2)) (P(x_1 x_2(i_1 i_2) | i_1 i_2 y) \cdot P'(x'_1 x'_2(i'_1 i'_2) | i'_1 i'_2 y')) \\
 &= \left( \sum_{i_1, i_2, x_1, x_2, y} W(y | x_1 x_2) P(x_1 x_2(i_1 i_2) | i_1 i_2 y) \right) \\
 &\quad \times \left( \sum_{x'_1, x'_2, y', i'_1, i'_2} W'(y' | x'_1 x'_2) P'(x'_1 x'_2(i'_1 i'_2) | i'_1 i'_2 y') \right) \\
 &= S^{\text{NS}}(W, k_1, k_2) \cdot S^{\text{NS}}(W', k'_1, k'_2).
 \end{aligned} \tag{4.35}$$

In particular, applying this  $n$  times on the same MAC  $W$  gives the first corollary, and the second one comes from the fact that  $S^{\text{NS}}(W \otimes W', k_1, k_2) \geq S^{\text{NS}}(W, k_1, k_2)$ .

$S^{\text{NS}}(W', 1, 1) = S^{\text{NS}}(W, k_1, k_2)$ , since  $S^{\text{NS}}(W', 1, 1) = 1$  by the first property of Proposition 4.9.

□

**Corollary 4.10.** 1.  $\mathcal{C}^{\text{NS}}(W)$  is convex.

2. If  $(R_1, R_2)$  is achievable with non-signaling assistance, then we have  $R_1 \leq \log_2 |\mathcal{X}_1|$ ,  $R_2 \leq \log_2 |\mathcal{X}_2|$  and  $R_1 + R_2 \leq \log_2 |\mathcal{Y}|$ .
3. If  $(R_1, R_2)$  is achievable with non-signaling assistance, then for all  $R'_i \leq R_i$ ,  $(R'_1, R'_2)$  is achievable with non-signaling assistance.

*Proof.* 1. It comes directly from Proposition 2.15 and the fourth property of Proposition 4.9.

2. By the second property of Proposition 4.9, we have  $S^{\text{NS}}(W^{\otimes n}, k_1^n, k_2^n) \leq \frac{|\mathcal{X}_1^n|}{k_1^n}$ . In particular, if  $R_1 > \log_2 |\mathcal{X}_1|$ , then  $k_1 > |\mathcal{X}_1|$  and we get that  $S^{\text{NS}}(W^{\otimes n}, k_1^n, k_2^n) \leq \left(\frac{|\mathcal{X}_1|}{k_1}\right)^n \xrightarrow{n \rightarrow +\infty} 0$ , so  $R_1 > \log_2 |\mathcal{X}_1|$  is not achievable with non-signaling assistance. Symmetrically,  $R_2 > \log_2 |\mathcal{X}_2|$  is not achievable with non-signaling assistance.

Furthermore, if one takes  $R_1 + R_2 > \log_2 |\mathcal{Y}|$ , then in particular  $k_1 k_2 > |\mathcal{Y}|$ , so by the second property of Proposition 4.9,  $S^{\text{NS}}(W^{\otimes n}, k_1^n, k_2^n) \leq \frac{|\mathcal{Y}^n|}{k_1^n k_2^n} = \left(\frac{|\mathcal{Y}|}{k_1 k_2}\right)^n \xrightarrow{n \rightarrow +\infty} 0$ . Thus,  $R_1 + R_2 > \log_2 |\mathcal{Y}|$  is not achievable with non-signaling assistance.

3. Since  $(R_1, R_2)$  is achievable with non-signaling assistance, we have by definition that  $S^{\text{NS}}(W^{\otimes n}, \lceil 2^{nR_1} \rceil, \lceil 2^{nR_2} \rceil) \xrightarrow{n \rightarrow +\infty} 1$ . But, for all positive integers  $n$ , we have that  $\lceil 2^{nR'_1} \rceil \leq \lceil 2^{nR_1} \rceil$  and  $\lceil 2^{nR'_2} \rceil \leq \lceil 2^{nR_2} \rceil$ , so by the third property of Proposition 4.9, we have that  $S^{\text{NS}}(W^{\otimes n}, \lceil 2^{nR'_1} \rceil, \lceil 2^{nR'_2} \rceil) \geq S^{\text{NS}}(W^{\otimes n}, \lceil 2^{nR_1} \rceil, \lceil 2^{nR_2} \rceil)$ . Thus  $S^{\text{NS}}(W^{\otimes n}, \lceil 2^{nR'_1} \rceil, \lceil 2^{nR'_2} \rceil) \xrightarrow{n \rightarrow +\infty} 1$  since it is upper bounded by 1, and so  $(R'_1, R'_2)$  is achievable with non-signaling assistance.

□

**Proposition 4.11.**  $\mathcal{C}_0^{\text{NS}}(W)$  is the closure of the set of rate pairs  $(R_1, R_2)$  such that:

$$\exists n \in \mathbb{N}^*, S^{\text{NS}}(W^{\otimes n}, \lceil 2^{R_1 n} \rceil, \lceil 2^{R_2 n} \rceil) = 1.$$

*Proof.* If  $(R_1, R_2)$  is such that  $\exists n_0 \in \mathbb{N}^*, \forall n \geq n_0, S^{\text{NS}}(W^{\otimes n}, \lceil 2^{R_1 n} \rceil, \lceil 2^{R_2 n} \rceil) = 1$ , then in particular  $\exists n \in \mathbb{N}^*, S^{\text{NS}}(W^{\otimes n}, \lceil 2^{R_1 n} \rceil, \lceil 2^{R_2 n} \rceil) = 1$ . So,  $\mathcal{C}_0^{\text{NS}}(W)$ , which is the closure of the former rate pairs, is in particular included in the closure of the latter rate pairs.

For the other inclusion, consider a rate pair  $(R_1, R_2)$  and let us assume that there exists some positive integer  $n$  such that  $S^{\text{NS}}(W^{\otimes n}, \lceil 2^{R_1 n} \rceil, \lceil 2^{R_2 n} \rceil) = 1$ . Let us show that for any  $(R'_1, R'_2)$  such that  $R'_1 < R_1$  and  $R'_2 < R_2$ :

$$\exists n_0 \in \mathbb{N}^*, \forall n \geq n_0, S^{\text{NS}}(W^{\otimes n}, \lceil 2^{R'_1 n} \rceil, \lceil 2^{R'_2 n} \rceil) = 1,$$

which is enough to conclude, since we consider only closure of such sets.

First, for all positive integers  $m$ , we have that  $S^{\text{NS}}(W^{\otimes nm}, \lceil 2^{R_1 nm} \rceil, \lceil 2^{R_2 nm} \rceil) = 1$ . By the fourth property of Proposition 4.9, we have that  $S^{\text{NS}}((W^{\otimes n})^{\otimes m}, \lceil 2^{R_1 n} \rceil^m, \lceil 2^{R_2 n} \rceil^m) \geq$

$[\text{S}^{\text{NS}}(W^{\otimes n}, \lceil 2^{R_1 n} \rceil, \lceil 2^{R_2 n} \rceil)]^m = 1$ , so  $\text{S}^{\text{NS}}((W^{\otimes n})^{\otimes m}, \lceil 2^{R_1 n} \rceil^m, \lceil 2^{R_2 n} \rceil^m) = 1$  since  $\text{S}^{\text{NS}}(W, k_1, k_2) \leq 1$  by the first property of Proposition 4.9. But  $(W^{\otimes n})^{\otimes m} = W^{\otimes nm}$ , and  $\lceil 2^{R_1 n} \rceil^m \geq \lceil 2^{R_1 nm} \rceil, \lceil 2^{R_2 n} \rceil^m \geq \lceil 2^{R_2 nm} \rceil$ , so by the third property of Proposition 4.9, we have  $\text{S}^{\text{NS}}(W^{\otimes nm}, \lceil 2^{R_1 nm} \rceil, \lceil 2^{R_2 nm} \rceil) \geq 1$ , so  $\text{S}^{\text{NS}}(W^{\otimes nm}, \lceil 2^{R_1 nm} \rceil, \lceil 2^{R_2 nm} \rceil) = 1$ .

Then, consider some  $r \in \{0, \dots, n-1\}$ . By the fourth property of Proposition 4.9, we have that:

$$\begin{aligned} \text{S}^{\text{NS}}(W^{\otimes(nm+r)}, \lceil 2^{R_1 nm} \rceil, \lceil 2^{R_2 nm} \rceil) &= \text{S}^{\text{NS}}(W^{\otimes nm} \otimes W^{\otimes r}, \lceil 2^{R_1 nm} \rceil, \lceil 2^{R_2 nm} \rceil) \\ &\geq \text{S}^{\text{NS}}(W^{\otimes nm}, \lceil 2^{R_1 nm} \rceil, \lceil 2^{R_2 nm} \rceil) = 1, \end{aligned} \quad (4.36)$$

so  $\text{S}^{\text{NS}}(W^{\otimes(nm+r)}, \lceil 2^{R_1 nm} \rceil, \lceil 2^{R_2 nm} \rceil) = 1$ .

But  $\lceil 2^{R_1 nm} \rceil = \lceil 2^{\frac{R_1 nm}{nm+r}(nm+r)} \rceil = \lceil 2^{\frac{R_1}{1+\delta}(nm+r)} \rceil$  with  $\delta = \frac{r}{nm} \leq \frac{1}{m}$ , and symmetrically  $\lceil 2^{R_2 nm} \rceil = \lceil 2^{\frac{R_2}{1+\delta}(nm+r)} \rceil$ . Thus in particular, for all  $R'_1 \leq \frac{R_1}{1+\frac{1}{m}}$  and  $R'_2 \leq \frac{R_2}{1+\frac{1}{m}}$ , we have that for all  $n' \geq nm$ ,  $\text{S}^{\text{NS}}(W^{\otimes n'}, \lceil 2^{R'_1 n'} \rceil, \lceil 2^{R'_2 n'} \rceil) = 1$ . So for any  $(R'_1, R'_2)$  such that  $R'_1 < R_1$  and  $R'_2 < R_2$ , there is large enough  $m$  such that  $R'_1 \leq \frac{R_1}{1+\frac{1}{m}}$  and  $R'_2 \leq \frac{R_2}{1+\frac{1}{m}}$ , and thus we get the expected property on  $(R'_1, R'_2)$  for  $n_0 := nm$ .  $\square$

### 4.3.3 Linear Program With Reduced Size for Structured Channels

Although  $\text{S}^{\text{NS}}(W, k_1, k_2)$  can be computed in polynomial time in  $W, k_1$  and  $k_2$ , a channel of the form  $W^{\otimes n}$  has exponential size in  $n$ . Thus, the linear program for  $\text{S}^{\text{NS}}(W^{\otimes n}, k_1, k_2)$  grows exponentially with  $n$ . However, using the invariance of  $W^{\otimes n}$  under permutations, one can find a much smaller linear program computing  $\text{S}^{\text{NS}}(W^{\otimes n}, k_1, k_2)$ .

**Definition 4.2.** Let  $G$  a group acting on  $\mathcal{X}_1, \mathcal{X}_2, \mathcal{Y}$ . We say that a MAC  $W : \mathcal{X}_1 \times \mathcal{X}_2 \rightarrow \mathcal{Y}$  is *invariant under the action of  $G$*  if:

$$\forall g \in G, W(g \cdot y | g \cdot x_1 g \cdot x_2) = W(y | x_1 x_2).$$

In particular, for  $W^{\otimes n} : \mathcal{X}_1^n \times \mathcal{X}_2^n \rightarrow \mathcal{Y}^n$ , the symmetric group  $G := \mathfrak{S}_n$  acts in a natural way in any set  $\mathcal{A}$  raised to power  $n$ . So for  $\sigma \in \mathfrak{S}_n$ , we have that:

$$\begin{aligned} W^{\otimes n}(\sigma \cdot y^n | \sigma \cdot x_1^n \sigma \cdot x_2^n) &= \prod_{i=1}^n W(y_{\sigma(i)} | x_{1,\sigma(i)} x_{2,\sigma(i)}) = \prod_{i=1}^n W(y_i | x_{1,i} x_{2,i}) \\ &= W^{\otimes n}(y^n | x_1^n x_2^n), \end{aligned} \quad (4.37)$$

and so  $W^{\otimes n}$  is invariant under the action of  $\mathfrak{S}_n$ .

Let  $\mathcal{Z} := \{\mathcal{X}_1, \mathcal{X}_2, \mathcal{Y}, \mathcal{X}_1 \times \mathcal{Y}, \mathcal{X}_2 \times \mathcal{Y}, \mathcal{X}_1 \times \mathcal{X}_2, \mathcal{X}_1 \times \mathcal{X}_2 \times \mathcal{Y}\}$ . Let us call  $\mathcal{O}_G(\mathcal{A})$  the set of orbits of  $\mathcal{A}$  under the action of  $G$ . Then, one can find an equivalent smaller linear program for  $\text{S}^{\text{NS}}(W, k_1, k_2)$ :

**Theorem 4.12.** Let  $W : \mathcal{X}_1 \times \mathcal{X}_2 \rightarrow \mathcal{Y}$  a MAC invariant under the action of  $G$ . Let us name systematically  $w \in \mathcal{O}_G(\mathcal{X}_1 \times \mathcal{X}_2 \times \mathcal{Y}), u \in \mathcal{O}_G(\mathcal{X}_1 \times \mathcal{X}_2), u^1 \in \mathcal{O}_G(\mathcal{X}_1), u^2 \in \mathcal{O}_G(\mathcal{X}_2), v^1 \in \mathcal{O}_G(\mathcal{X}_1 \times \mathcal{Y}), v^2 \in \mathcal{O}_G(\mathcal{X}_2 \times \mathcal{Y}), v \in \mathcal{O}_G(\mathcal{Y})$ . We will also call  $z_{\mathcal{A}}$  the projection of  $z \in \mathcal{O}_G(\mathcal{B})$  on  $\mathcal{A}$ , for  $\mathcal{A}, \mathcal{B} \in \mathcal{Z}$  and  $\mathcal{A}$  projection of  $\mathcal{B}$ ; note that  $z_{\mathcal{A}} \in \mathcal{O}_G(\mathcal{A})$ , since by definition of the action, the projection of an orbit is an orbit. Let us finally call

$W(w) := W(y|x_1x_2)$  for any  $(x_1, x_2, y) \in w$ , which is well-defined since  $W$  is invariant under  $G$ . We have that  $S^{\text{NS}}(W, k_1, k_2)$  is the solution of the following linear program:

$$\begin{aligned}
 & \underset{r, r^1, r^2, p}{\text{maximize}} && \frac{1}{k_1 k_2} \sum_{w \in \mathcal{O}_G(\mathcal{X}_1 \times \mathcal{X}_2 \times \mathcal{Y})} W(w) r_w \\
 & \text{subject to} && \sum_{w: w_{\mathcal{Y}}=v} r_w = |v|, \forall v \in \mathcal{O}_G(\mathcal{Y}) \\
 & && \sum_{w: w_{\mathcal{X}_2 \mathcal{Y}}=v^2} r_w^1 = k_1 \sum_{w: w_{\mathcal{X}_2 \mathcal{Y}}=v^2} r_w, \forall v^2 \in \mathcal{O}_G(\mathcal{X}_2 \times \mathcal{Y}) \\
 & && \sum_{w: w_{\mathcal{X}_1 \mathcal{Y}}=v^1} r_w^2 = k_2 \sum_{w: w_{\mathcal{X}_1 \mathcal{Y}}=v^1} r_w, \forall v^1 \in \mathcal{O}_G(\mathcal{X}_1 \times \mathcal{Y}) \\
 & && \sum_{u: u_{\mathcal{X}_2}=v_{\mathcal{X}_2}^2} p_u = \frac{|v_{\mathcal{X}_2}^2|}{|v^2|} k_1 \sum_{w: w_{\mathcal{X}_2 \mathcal{Y}}=v^2} r_w^2, \forall v^2 \in \mathcal{O}_G(\mathcal{X}_2 \times \mathcal{Y}) \\
 & && \sum_{u: u_{\mathcal{X}_1}=v_{\mathcal{X}_1}^1} p_u = \frac{|v_{\mathcal{X}_1}^1|}{|v^1|} k_2 \sum_{w: w_{\mathcal{X}_1 \mathcal{Y}}=v^1} r_w^1, \forall v^1 \in \mathcal{O}_G(\mathcal{X}_1 \times \mathcal{Y}) \\
 & && 0 \leq r_w \leq r_w^1, r_w^2 \leq \frac{|w|}{|w_{\mathcal{X}_1 \mathcal{X}_2}|} p_{w_{\mathcal{X}_1 \mathcal{X}_2}}, \forall w \in \mathcal{O}_G(\mathcal{X}_1 \times \mathcal{X}_2 \times \mathcal{Y}) \\
 & && \frac{|w|}{|w_{\mathcal{X}_1 \mathcal{X}_2}|} p_{w_{\mathcal{X}_1 \mathcal{X}_2}} - r_w^1 - r_w^2 + r_w \geq 0, \forall w \in \mathcal{O}_G(\mathcal{X}_1 \times \mathcal{X}_2 \times \mathcal{Y}).
 \end{aligned} \tag{4.38}$$

**Corollary 4.13.** For a channel  $W : \mathcal{X}_1 \times \mathcal{X}_2 \rightarrow \mathcal{Y}$ ,  $S^{\text{NS}}(W^{\otimes n}, k_1, k_2)$  is the solution of a linear program of size bounded by  $O(n^{|\mathcal{X}_1| \cdot |\mathcal{X}_2| \cdot |\mathcal{Y}| - 1})$ , thus it can be computed in polynomial time in  $n$ .

*Proof.* We use the linear program obtained in Theorem 4.12 with  $G := \mathfrak{S}_n$  acting on  $W^{\otimes n}$  as described before. The number of variables and constraints is linear in the number of orbits of the action of  $\mathfrak{S}_n$  on the different sets  $\mathcal{A} \in \mathcal{Z}$ , where here  $\mathcal{Z} := \{\mathcal{X}_1^n, \mathcal{X}_2^n, \mathcal{Y}^n, \mathcal{X}_1^n \times \mathcal{Y}^n, \mathcal{X}_2^n \times \mathcal{Y}^n, \mathcal{X}_1^n \times \mathcal{X}_2^n, \mathcal{X}_1^n \times \mathcal{X}_2^n \times \mathcal{Y}^n\}$ . For example, for  $\mathcal{A} \in \mathcal{X}_1^n \times \mathcal{X}_2^n \times \mathcal{Y}^n$ , we have that:

$$|\mathcal{O}_{\mathfrak{S}_n}(\mathcal{X}_1^n \times \mathcal{X}_2^n \times \mathcal{Y}^n)| = \binom{n + |\mathcal{X}_1| |\mathcal{X}_2| |\mathcal{Y}| - 1}{|\mathcal{X}_1| |\mathcal{X}_2| |\mathcal{Y}| - 1} \leq (n + |\mathcal{X}_1| |\mathcal{X}_2| |\mathcal{Y}| - 1)^{|\mathcal{X}_1| |\mathcal{X}_2| |\mathcal{Y}| - 1}.$$

So the number of variables and constraints is  $O(n^{|\mathcal{X}_1| \cdot |\mathcal{X}_2| \cdot |\mathcal{Y}| - 1})$ . Note also that all the numbers occurring in this linear program are integers or fractions of integers, with those integers ranging in  $[(|\mathcal{X}_1| |\mathcal{X}_2| |\mathcal{Y}|)^n]$ , thus of size  $O(n \log(|\mathcal{X}_1| |\mathcal{X}_2| |\mathcal{Y}|))$ . So the size of this linear program is bounded by  $O(n^{|\mathcal{X}_1| \cdot |\mathcal{X}_2| \cdot |\mathcal{Y}| - 1})$ , and thus  $S^{\text{NS}}(W^{\otimes n}, k_1, k_2)$  can be computed in polynomial time in  $n$ ; see for instance Section 7.1 of [GM07].  $\square$

In order to prove Theorem 4.12, we will need several lemmas. For all of them,  $\mathcal{A}$  and  $\mathcal{B}$  will denote finite sets on which a group  $G$  is acting, and  $x^G$  will denote the orbit of  $x$  under  $G$ :

**Lemma 4.14.** Let  $\tau \in \mathcal{O}_G(\mathcal{A} \times \mathcal{B})$ , and call  $\nu := \tau_{\mathcal{A}}$  and  $\mu := \tau_{\mathcal{B}}$ . For  $x \in \nu$ , let us call  $B_{\tau}^x := \{y : (x, y) \in \tau\}$ . Then,  $|B_{\tau}^x| = |B_{\tau}^{x'}| =: c_{\tau}'$  for any  $x, x' \in \nu$ , and furthermore, we

have that  $c_\tau^\nu = \frac{|\tau|}{|\nu|}$ . Symmetrically, the same occurs for  $A_\tau^y := \{x : (x, y) \in \tau\}$  with  $y \in \mu$ , where one gets that  $|A_\tau^y| = |A_\tau^{y'}| =: c_\tau^\mu = \frac{|\tau|}{|\mu|}$  for  $y, y' \in \mu$ .

*Proof.* Let  $x, x' \in \nu$ . Thus there exists  $g \in G$  such that  $x' = g \cdot x$ . Let:

$$\begin{aligned} f &: B_\tau^x \rightarrow B_\tau^{x'} \\ y &\mapsto g \cdot y. \end{aligned}$$

First,  $f$  is well defined. Indeed, if  $y \in B_\tau^x = \{y : (x, y) \in \tau\}$ , then we have that  $g \cdot y \in \{y : (g \cdot x, y) \in \tau\} = B_\tau^{x'}$ , since  $\tau \in \mathcal{O}_G(\mathcal{A} \times \mathcal{B})$ . Let us show that  $f$  is injective. If  $g \cdot y = g \cdot y'$ , then  $g^{-1} \cdot (g \cdot y) = (g^{-1}g) \cdot y = y$ ,  $g^{-1} \cdot (g \cdot y') = y'$ , so  $y = y'$ . Thus we get that  $|B_\tau^x| \leq |B_\tau^{x'}|$ . By a symmetric argument with  $x'$  replacing  $x$  and  $g^{-1}$  replacing  $g$ , we get that  $|B_\tau^{x'}| \leq |B_\tau^x|$ , and so  $|B_\tau^x| = |B_\tau^{x'}| =: c_\tau^\nu$ .

Furthermore,  $\{B_\tau^x\}_{x \in \nu}$  is a partition of  $\tau$ , so  $\sum_{x \in \nu} |B_\tau^x| = |\nu|c_\tau^\nu = |\tau|$ , and  $c_\tau^\nu = \frac{|\tau|}{|\nu|}$ .  $\square$

**Lemma 4.15.** For any  $(x, y) \in \mathcal{A} \times \mathcal{B}$  and  $v_{(x,y)G}$  variable indexed by orbits of  $\mathcal{A} \times \mathcal{B}$ , let us define the variable  $v_{x,y} := \frac{v_{(x,y)G}}{|(x,y)G|}$ . We have:

$$\sum_{x \in \mathcal{A}} v_{x,y} = \frac{1}{|y^G|} \sum_{\tau \in \mathcal{O}_G(\mathcal{A} \times \mathcal{B}) : \tau_B = y^G} v_\tau, \forall y \in \mathcal{B}.$$

*Proof.*

$$\begin{aligned} \sum_{x \in \mathcal{A}} v_{x,y} &= \sum_{\tau \in \mathcal{O}_G(\mathcal{A} \times \mathcal{B}) : \tau_B = y^G} \sum_{x \in \mathcal{A} : (x,y) \in \tau} v_{x,y} \\ &= \sum_{\tau \in \mathcal{O}_G(\mathcal{A} \times \mathcal{B}) : \tau_B = y^G} \sum_{x \in \mathcal{A} : (x,y) \in \tau} \frac{v_\tau}{|\tau|} \quad \text{since } (x,y)^G = \tau \\ &= \sum_{\tau \in \mathcal{O}_G(\mathcal{A} \times \mathcal{B}) : \tau_B = y^G} c_\tau^{y^G} \frac{v_\tau}{|\tau|} \quad \text{by Lemma 4.14, since } y \in \tau_B \\ &= \sum_{\tau \in \mathcal{O}_G(\mathcal{A} \times \mathcal{B}) : \tau_B = y^G} \frac{|\tau|}{|y^G|} \frac{v_\tau}{|\tau|} = \frac{1}{|y^G|} \sum_{\tau \in \mathcal{O}_G(\mathcal{A} \times \mathcal{B}) : \tau_B = y^G} v_\tau. \end{aligned} \tag{4.39}$$

$\square$

**Lemma 4.16.** For any  $\tau \in \mathcal{O}_G(\mathcal{A} \times \mathcal{B})$ ,  $\mu \in \mathcal{O}_G(\mathcal{B})$  and  $v_{x,y}$  variable indexed by elements of  $\mathcal{A} \times \mathcal{B}$ , let us define  $v_\tau := \sum_{(x,y) \in \tau} v_{x,y}$ . We have:

$$\sum_{\tau \in \mathcal{O}_G(\mathcal{A} \times \mathcal{B}) : \tau_B = \mu} v_\tau = \sum_{y \in \mu} \sum_{x \in \mathcal{A}} v_{x,y}.$$

*Proof.*

$$\sum_{\tau \in \mathcal{O}_G(\mathcal{A} \times \mathcal{B}) : \tau_B = \mu} v_\tau = \sum_{\tau \in \mathcal{O}_G(\mathcal{A} \times \mathcal{B}) : \tau_B = \mu} \sum_{(x,y) \in \tau} v_{x,y} = \sum_{y \in \mu} \sum_{x \in \mathcal{A}} v_{x,y}.$$

$\square$



*Proof of Theorem 4.12.* Let  $r_{x_1,x_2,y}, r_{x_1,x_2,y}^1, r_{x_1,x_2,y}^2, p_{x_1,x_2}$  a feasible solution of the program defined in Proposition 4.7, and call  $S := \frac{1}{k_1 k_2} \sum_{x_1,x_2,y} W(y|x_1 x_2) r_{x_1,x_2,y}$  its value. Define:

$$\begin{aligned} r_w &:= \sum_{(x_1,x_2,y) \in w} r_{x_1,x_2,y}, & r_w^1 &:= \sum_{(x_1,x_2,y) \in w} r_{x_1,x_2,y}^1, \\ r_w^2 &:= \sum_{(x_1,x_2,y) \in w} r_{x_1,x_2,y}^2, & p_u &:= \sum_{(x_1,x_2) \in u} p_{x_1,x_2}. \end{aligned} \quad (4.40)$$

Let us show that  $r_w, r_w^1, r_w^2, p_u$  is a feasible solution of the program defined in Theorem 4.12, and that its value  $S^* := \frac{1}{k_1 k_2} \sum_w W(w) r_w = S$ .

First, we have  $S^* = S$ . Indeed:

$$\begin{aligned} S^* &= \frac{1}{k_1 k_2} \sum_w W(w) r_w = \frac{1}{k_1 k_2} \sum_w W(w) \sum_{(x_1,x_2,y) \in w} r_{x_1,x_2,y} \\ &= \frac{1}{k_1 k_2} \sum_w \sum_{(x_1,x_2,y) \in w} W(y|x_1 x_2) r_{x_1,x_2,y} \\ &= \frac{1}{k_1 k_2} \sum_{x_1,x_2,y} W(y|x_1 x_2) r_{x_1,x_2,y} = S. \end{aligned} \quad (4.41)$$

Then, all the constraints are satisfied. Indeed, thanks to Lemma 4.16, we have for the first constraint:

$$\sum_{w:w\mathcal{X}_2=v} r_w = \sum_{y \in v} \sum_{x_1,x_2} r_{x_1,x_2,y} = \sum_{y \in v} 1 = |v|.$$

For the second constraint (and symmetrically for the third constraint), we have:

$$\sum_{w:w\mathcal{X}_2=v^2} r_w^1 = \sum_{(x_2,y) \in v^2} \sum_{x_1} r_{x_1,x_2,y}^1 = \sum_{(x_2,y) \in v^2} k_1 \sum_{x_1} r_{x_1,x_2,y} = k_1 \sum_{w:w\mathcal{X}_2=v^2} r_w.$$

For the fourth (and symmetrically for the fifth), we have:

$$\begin{aligned} \sum_{w:w\mathcal{X}_2=v^2} r_w^2 &= \sum_{(x_2,y) \in v^2} \sum_{x_1} r_{x_1,x_2,y}^2 = \sum_{(x_2,y) \in v^2} \frac{1}{k_1} \sum_{x_1} p_{x_1,x_2} \\ &= \frac{1}{k_1} \sum_{x_2 \in v^2_{\mathcal{X}_2}} \sum_{y:(x_2,y) \in v^2} \sum_{x_1} p_{x_1,x_2} \\ &= \frac{1}{k_1} \sum_{x_2 \in v^2_{\mathcal{X}_2}} \frac{|v^2|}{|v^2_{\mathcal{X}_2}|} \sum_{x_1} p_{x_1,x_2} \quad \text{thanks to Lemma 4.14} \\ &= \frac{1}{k_1} \frac{|v^2|}{|v^2_{\mathcal{X}_2}|} \sum_{u:u\mathcal{X}_2=v^2_{\mathcal{X}_2}} p_u. \end{aligned} \quad (4.42)$$

Finally for the last constraints, we only need to compute:

$$\begin{aligned} \sum_{(x_1,x_2,y) \in w} p_{x_1,x_2} &= \sum_{(x_1,x_2) \in w\mathcal{X}_1\mathcal{X}_2} \sum_{y:(x_1,x_2,y) \in w} p_{x_1,x_2} = \sum_{(x_1,x_2) \in w\mathcal{X}_1\mathcal{X}_2} \frac{|w|}{|w\mathcal{X}_1\mathcal{X}_2|} p_{x_1,x_2} \\ &= \frac{|w|}{|w\mathcal{X}_1\mathcal{X}_2|} p_{w\mathcal{X}_1\mathcal{X}_2}, \end{aligned} \quad (4.43)$$

which implies that the linear inequalities on  $p_{x_1,x_2}, r_{x_1,x_2,y}, r_{x_1,x_2,y}^1, r_{x_1,x_2,y}^2$  get transposed respectively to the values  $\frac{|w|}{|w\chi_1\chi_2|}p_{w\chi_1\chi_2}, r_w, r_w^1, r_w^2$ . Indeed, for instance, one has for any  $x_1, x_2, y$  that  $p_{x_1,x_2} - r_{x_1,x_2,y}^1 - r_{x_1,x_2,y}^2 + r_{x_1,x_2,y} \geq 0$ . Thus for some orbit  $w$ :

$$\sum_{(x_1,x_2,y) \in w} \left( p_{x_1,x_2} - r_{x_1,x_2,y}^1 - r_{x_1,x_2,y}^2 + r_{x_1,x_2,y} \right) \geq 0,$$

and then  $\frac{|w|}{|w\chi_1\chi_2|}p_{w\chi_1\chi_2} - r_w^1 - r_w^2 + r_w \geq 0$ , which was what we wanted to show.

Now let us consider a feasible solution  $r_w, r_w^1, r_w^2, p_u$  of the program defined in Theorem 4.12, with a value  $S^* := \frac{1}{k_1 k_2} \sum_w W(w)r_w$ . Define:

$$\begin{aligned} r_{x_1,x_2,y} &:= \frac{r_{(x_1,x_2,y)}^G}{|(x_1,x_2,y)^G|}, & r_{x_1,x_2,y}^1 &:= \frac{r_{(x_1,x_2,y)}^1 G}{|(x_1,x_2,y)^G|}, \\ r_{x_1,x_2,y}^2 &:= \frac{r_{(x_1,x_2,y)}^2 G}{|(x_1,x_2,y)^G|}, & p_{x_1,x_2} &:= \frac{p_{(x_1,x_2)}^G}{|(x_1,x_2)^G|}. \end{aligned} \quad (4.44)$$

Let us show that  $r_{x_1,x_2,y}, r_{x_1,x_2,y}^1, r_{x_1,x_2,y}^2, p_{x_1,x_2}$  is a feasible solution of the program defined in Proposition 4.7, and that its value  $S := \frac{1}{k_1 k_2} \sum_{x_1,x_2,y} W(y|x_1x_2)r_{x_1,x_2,y} = S^*$ .

First we have  $S = S^*$ . Indeed:

$$\begin{aligned} S &= \frac{1}{k_1 k_2} \sum_{x_1,x_2,y} W(y|x_1x_2)r_{x_1,x_2,y} = \frac{1}{k_1 k_2} \sum_{x_1,x_2,y} W(y|x_1x_2) \frac{r_{(x_1,x_2,y)}^G}{|r_{(x_1,x_2,y)}^G|} \\ &= \frac{1}{k_1 k_2} \sum_w \sum_{(x_1,x_2,y) \in w} W(y|x_1x_2) \frac{r_w}{|w|} = \frac{1}{k_1 k_2} \sum_w \sum_{(x_1,x_2,y) \in w} W(w) \frac{r_w}{|w|} \\ &= \frac{1}{k_1 k_2} \sum_w |w| W(w) \frac{r_w}{|w|} = \frac{1}{k_1 k_2} \sum_w W(w)r_w = S^*. \end{aligned} \quad (4.45)$$

Then, all the constraints are satisfied. Indeed, thanks to Lemma 4.15, we have for the first constraint:

$$\sum_{x_1,x_2} r_{x_1,x_2,y} = \frac{1}{|y^G|} \sum_{w:w\chi_2=y^G} r_w = \frac{|y^G|}{|y^G|} = 1.$$

For the second constraint (and symmetrically for the third constraint), we have:

$$\begin{aligned} \sum_{x_1} r_{x_1,x_2,y}^1 &= \frac{1}{|(x_2,y)^G|} \sum_{w:w\chi_2y=(x_2,y)^G} r_w^1 = \frac{k_1}{|(x_2,y)^G|} \sum_{w:w\chi_2y=(x_2,y)^G} r_w \\ &= k_1 \sum_{x_1} r_{x_1,x_2,y}. \end{aligned} \quad (4.46)$$

For the fourth (and symmetrically for the fifth), we have:

$$\begin{aligned}
 \sum_{x_1} r_{x_1, x_2, y}^2 &= \frac{1}{|(x_2, y)^G|} \sum_{w: w\mathcal{X}_2 y = (x_2, y)^G} r_w^2 = \frac{1}{|(x_2, y)^G|} \frac{1}{k_1} \frac{|(x_2, y)^G|}{|(x_2, y)_{\mathcal{X}_2}^G|} \sum_{u: u\mathcal{X}_2 = (x_2, y)_{\mathcal{X}_2}^G} p_u \\
 &= \frac{1}{k_1} \frac{1}{|(x_2, y)_{\mathcal{X}_2}^G|} \sum_{u: u\mathcal{X}_2 = (x_2, y)_{\mathcal{X}_2}^G} p_u \\
 &= \frac{1}{k_1} \frac{1}{|x_2^G|} \sum_{u: u\mathcal{X}_2 = x_2^G} p_u \text{ since } (x_2, y)_{\mathcal{X}_2}^G = x_2^G \\
 &= \frac{1}{k_1} \sum_{x_1} p_{x_1, x_2} .
 \end{aligned} \tag{4.47}$$

Finally, to conclude with the last constraints, one has only to see that for any  $x_1, x_2, y$ :

$$\frac{|(x_1, x_2, y)^G|}{|(x_1, x_2, y)_{\mathcal{X}_1 \mathcal{X}_2}^G|} p_{(x_1, x_2, y)_{\mathcal{X}_1 \mathcal{X}_2}^G} = \frac{|(x_1, x_2, y)^G|}{|(x_1, x_2)^G|} p_{(x_1, x_2)^G} = |(x_1, x_2, y)^G| p_{x_1, x_2} ,$$

which implies that the linear inequalities on  $\frac{|w|}{|w\mathcal{X}_1 \mathcal{X}_2|} p_{w\mathcal{X}_1 \mathcal{X}_2}, r_w, r_w^1, r_w^2$  get transposed respectively to the values  $p_{x_1, x_2}, r_{x_1, x_2, y}, r_{x_1, x_2, y}^1, r_{x_1, x_2, y}^2$ . Indeed, for instance, one has for any  $w$  that  $\frac{|w|}{|w\mathcal{X}_1 \mathcal{X}_2|} p_{w\mathcal{X}_1 \mathcal{X}_2} - r_w^1 - r_w^2 + r_w \geq 0$ . But for any  $(x_1, x_2, y) \in w$ , one has that  $r_{x_1, x_2, y} = \frac{r_w}{|w|}, r_{x_1, x_2, y}^1 = \frac{r_w^1}{|w|}, r_{x_1, x_2, y}^2 = \frac{r_w^2}{|w|}$ . Thanks to the previous inequality, we have that  $p_{x_1, x_2} = \frac{p_{w\mathcal{X}_1 \mathcal{X}_2}}{|w\mathcal{X}_1 \mathcal{X}_2|}$ , and thus:

$$p_{x_1, x_2} - r_{x_1, x_2, y}^1 - r_{x_1, x_2, y}^2 + r_{x_1, x_2, y} = \frac{p_{w\mathcal{X}_1 \mathcal{X}_2}}{|w\mathcal{X}_1 \mathcal{X}_2|} - \frac{r_w^1}{|w|} - \frac{r_w^2}{|w|} + \frac{r_w}{|w|} \geq 0 ,$$

which was what we wanted to show.  $\square$

## 4.4 Non-Signaling Achievability Bounds

### 4.4.1 Zero-Error Non-Signaling Assisted Achievable Rate Pairs

We will now present a numerical method to find efficiently inner bounds on  $\mathcal{C}_0^{\text{NS}}(W)$ . Thanks to Corollary 4.13, we know how to decide in polynomial time in  $n, k_1, k_2$  whether  $\text{S}^{\text{NS}}(W^{\otimes n}, k_1, k_2) = 1$ . However, by Proposition 4.11, if  $\text{S}^{\text{NS}}(W^{\otimes n}, k_1, k_2) = 1$ , then we have that  $\left(\frac{\log(k_1)}{n}, \frac{\log(k_2)}{n}\right) \in \mathcal{C}_0^{\text{NS}}(W)$ , which describes a way of computing achievable points for that capacity region. More precisely, this leads to the following result:

**Proposition 4.17** (Inner Bounds on  $\mathcal{C}_0^{\text{NS}}(W)$ ). *Let us define the zero-error non-signaling assisted  $n$ -shots capacity region  $\mathcal{C}_{0, \leq n}^{\text{NS}}(W)$  in the following way:*

$$\mathcal{C}_{0, \leq n}^{\text{NS}}(W) := \left\{ \left( \frac{\log(k_1)}{n}, \frac{\log(k_2)}{n} \right) : \text{S}^{\text{NS}}(W^{\otimes n}, k_1, k_2) = 1 \right\} .$$

*Then, we have that  $\forall n \in \mathbb{N}, \mathcal{C}_{0, \leq n}^{\text{NS}}(W) \subseteq \mathcal{C}_0^{\text{NS}}(W)$ , and that one can decide in polynomial time in  $n, k_1, k_2$  if  $\left(\frac{\log(k_1)}{n}, \frac{\log(k_2)}{n}\right) \in \mathcal{C}_{0, \leq n}^{\text{NS}}(W)$ .*

This implies that we can find efficiently achievable rate pairs for MACs.

**Application to the binary adder channel** The binary adder channel  $W_{\text{BAC}}$  is defined by:

$$\forall x_1, x_2 \in \{0, 1\}, \forall y \in \{0, 1, 2\}, W_{\text{BAC}}(y|x_1x_2) := \mathbb{1}_{y=x_1+x_2}.$$

Its classical capacity region  $\mathcal{C}(W_{\text{BAC}})$  is well known and consists of all  $(R_1, R_2)$  such that  $R_1 \leq 1, R_2 \leq 1, R_1 + R_2 \leq \frac{3}{2}$ , as a consequence of Theorem 4.1. Its zero-error classical capacity  $\mathcal{C}_0(W_{\text{BAC}})$  is not yet characterized. A lot of work has been done in finding outer and inner bounds on this region [Lin69, vT78, KL78, Jr.78, KLWY83, vdBvT85, BB98, UL98, AB99, MÖ05, OS15]. To date, the best lower bound on the sum-rate capacity is  $\log_2(240/6) \simeq 1.3178$  [MÖ05].

Thanks to Proposition 4.17, we were able to compute the regions  $\mathcal{C}_{0, \leq n}^{\text{NS}}(W)$  for  $n$  going up to 7, which led to Figure 4.4. The code can be found on [GitHub](#). It uses Mosek linear programming solver [AA00].

Note that the linear program from Theorem 4.12 has still a large number of variables and constraints although polynomial in  $n$ . Specifically, for  $n = 2$ , it has 244 variables and 480 constraints; for  $n = 3$ , it has 1112 variables and 2054 constraints; for  $n = 7$ , it has 95592 variables and 162324 constraints; finally, for  $n = 8$ , it has 226911 variables and 383103 constraints.

The first noticeable result coming from these curves is that the zero-error non-signaling assisted sum-rate capacity beats with only 7 copies the classical sum-rate capacity of  $\frac{3}{2}$ , even without a zero-error constraint, with a value of  $\frac{2 \log_2(42)}{7} \simeq 1.5406$ , coming from the fact that  $S^{\text{NS}}(W_{\text{BAC}}^{\otimes 7}, 42, 42) = 1$  and Proposition 4.11. This implies that  $\mathcal{C}_0^{\text{NS}}(W_{\text{BAC}})$  has larger sum-rate pairs than  $\mathcal{C}(W_{\text{BAC}})$ , and that  $\mathcal{C}^{\text{NS}}(W_{\text{BAC}})$  is strictly larger than  $\mathcal{C}(W_{\text{BAC}})$ . This sum-rate can even be increased up to  $\frac{\log_2(72)}{4} \simeq 1.5425$ , since we have computed  $S^{\text{NS}}(W_{\text{BAC}}^{\otimes 8}, 72, 72) = 1$ , which is the largest number of copies we have been able to manage with our efficient version of the linear program from Theorem 4.12. This should be compared with the upper bound on the non-signaling assisted sum-rate capacity coming from Proposition 4.26, which is  $\log_2(3) \simeq 1.5850$  for  $R_1 = R_2$ .

Another surprising property is the speed at which one obtains efficient zero-error non-signaling assisted codes compared to classical zero-error codes. Indeed, with only three copies of the binary adder channel, one gets that  $S^{\text{NS}}(W_{\text{BAC}}^{\otimes 3}, 4, 5) = 1$ , which corresponds to a sum-rate of  $\frac{2 + \log_2(5)}{3} \simeq 1.4406$ , which already largely beats the best known zero-error achieved sum-rate of  $\log_2(240/6) \simeq 1.3178$  [MÖ05]. These results are summarized in the following theorem:

**Theorem 4.18.** *We have that  $(\frac{\log_2(72)}{8}, \frac{\log_2(72)}{8}) \in \mathcal{C}_0^{\text{NS}}(W_{\text{BAC}})$  but  $(\frac{\log_2(72)}{8}, \frac{\log_2(72)}{8}) \notin \mathcal{C}(W_{\text{BAC}})$ , and as a consequence, we have that  $\mathcal{C}(W_{\text{BAC}}) \subsetneq \mathcal{C}^{\text{NS}}(W_{\text{BAC}})$ .*

*Proof.* Since  $2^{8 \frac{\log_2(72)}{8}} = 72$  and numerically  $S^{\text{NS}}(W_{\text{BAC}}^{\otimes 8}, 72, 72) = 1$  thanks to Corollary 4.13, we get that  $(\frac{\log_2(72)}{8}, \frac{\log_2(72)}{8}) \in \mathcal{C}_0^{\text{NS}}(W_{\text{BAC}})$  by Proposition 4.11. However,  $\frac{\log_2(72)}{8} + \frac{\log_2(72)}{8} > \frac{3}{2}$  so  $(\frac{\log_2(72)}{8}, \frac{\log_2(72)}{8}) \notin \mathcal{C}(W_{\text{BAC}})$  by Theorem 4.1 applied to  $W_{\text{BAC}}$ . Since  $\mathcal{C}(W_{\text{BAC}}) \subseteq \mathcal{C}^{\text{NS}}(W_{\text{BAC}})$  and  $\mathcal{C}_0^{\text{NS}}(W_{\text{BAC}}) \subseteq \mathcal{C}^{\text{NS}}(W_{\text{BAC}})$ , we thus get that  $\mathcal{C}(W_{\text{BAC}}) \subsetneq \mathcal{C}^{\text{NS}}(W_{\text{BAC}})$ .  $\square$

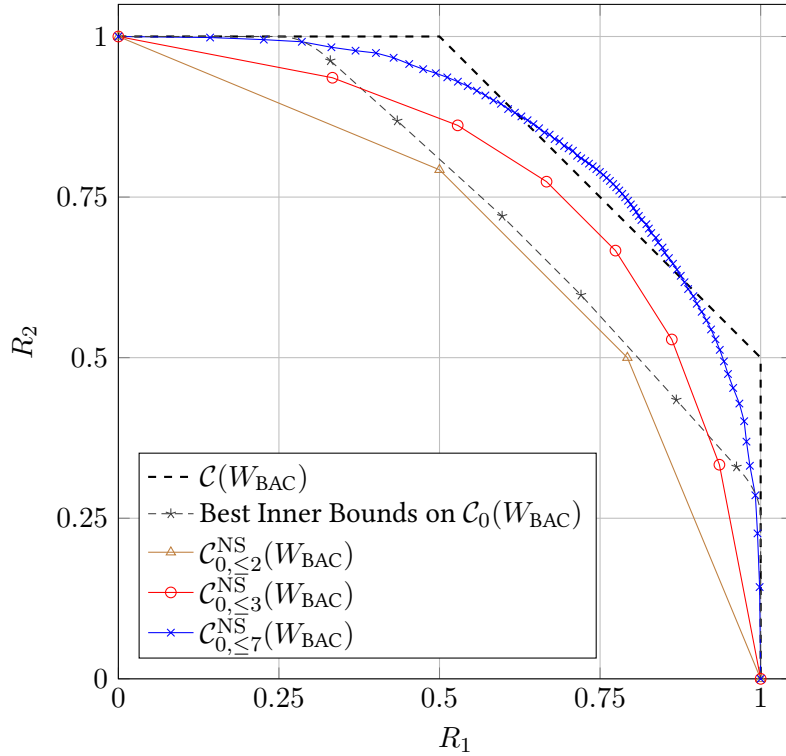

Figure 4.4 – Capacity regions of the binary adder channel  $W_{\text{BAC}}$ . The black dashed curve depicts the classical capacity region  $\mathcal{C}(W_{\text{BAC}})$ , whereas the grey dashed curve shows the best known inner bound border on the zero-error classical capacity region  $\mathcal{C}_0(W_{\text{BAC}})$ , made from results by [MÖ05, vdBvT85, KLWY83]; see [MÖ05] for a description of this border. On the other hand, the continuous curves depict the best zero-error non-signaling assisted achievable rate pairs for respectively 2, 3 and 7 copies of the binary adder channel.

#### 4.4.2 Non-Signaling Assisted Achievable Rate Pairs With Non-Zero Error

We have analyzed the non-signaling assisted capacity region through zero-error strategies and applied it to the BAC. However, if some noise is added to that channel, its zero-error non-signaling assisted capacity region becomes trivial (see Proposition 4.21). Thus, the previous method fails to find significant inner bounds on the non-signaling assisted capacity region of noisy MACs.

In this section, we use concatenated codes to obtain achievable rate pairs, and apply it to a noisy version of the BAC:

**Definition 4.3** (Concatenated Codes). Given a MAC  $W$  and a non-signaling assisted code  $P$ , let  $W[P] : [k_1] \times [k_2] \rightarrow [\ell]$  with  $W[P](j|i_1i_2) := \sum_{x_1, x_2, y} W(y|x_1x_2)P(x_1x_2j|i_1i_2y)$ :

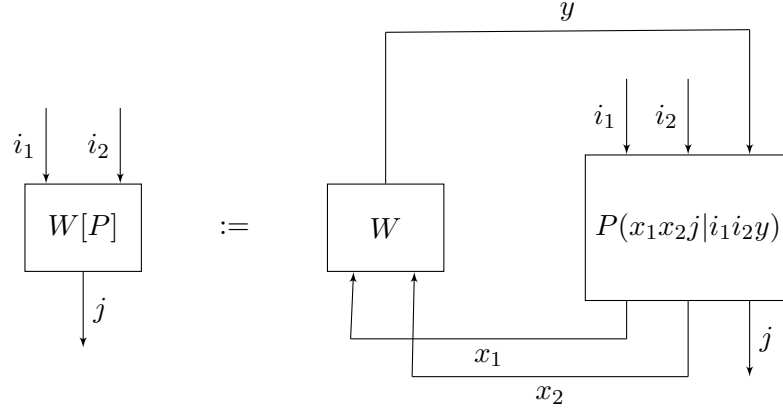

Note that  $W[P]$  is a MAC since  $W[P](j|i_1i_2) \geq 0$  and:

$$\begin{aligned}
 \sum_j W[P](j|i_1i_2) &= \sum_{x_1, x_2, y} W(y|x_1x_2) \sum_j P(x_1x_2j|i_1i_2y) \\
 &= \sum_{x_1, x_2} \left( \sum_y W(y|x_1x_2) \right) P(x_1x_2|i_1i_2) \text{ since } P \text{ is non-signaling} \\
 &= \sum_{x_1, x_2} P(x_1x_2|i_1i_2) = 1.
 \end{aligned} \tag{4.48}$$

The following proposition states that combining a classical code to a non-signaling strategy leads to inner bounds on the non-signaling assisted capacity region of a MAC:

**Proposition 4.19.** *If  $P$  is a non-signaling assisted code for the MAC  $W$ , we have that  $\mathcal{C}(W[P]) \subseteq \mathcal{C}^{\text{NS}}(W)$ .*

*Proof.* Let  $(R_1, R_2) \in \mathcal{C}(W[P])$ . Then, by definition, we have that:

$$\lim_{n \rightarrow +\infty} S(W[P]^{\otimes n}, [2^{R_1 n}], [2^{R_2 n}]) = 1.$$

Let us fix  $\varepsilon > 0$ . For a large enough  $N$ , we have  $S(W[P]^{\otimes N}, [2^{R_1 N}], [2^{R_2 N}]) \geq 1 - \varepsilon$ . Let us call  $\ell_1 := [2^{R_1 N}]$  and  $\ell_2 := [2^{R_2 N}]$ . Thus, there exists encoders  $e_1 : [\ell_1] \rightarrow [k_1]$ ,  $e_2 : [\ell_2] \rightarrow [k_2]$  and a decoder  $d : [\ell] \rightarrow [\ell_1] \times [\ell_2]$  such that:

$$\frac{1}{\ell_1 \ell_2} \sum_{i_1, i_2, j} W[P](j|i_1i_2) \sum_{a_1 \in [\ell_1], a_2 \in [\ell_2]} e_1(i_1|a_1) e_2(i_2|a_2) d(a_1 a_2 | j) \geq 1 - \varepsilon.$$

In particular, we have:

$$\frac{1}{\ell_1 \ell_2} \sum_{x_1, x_2, y} W(y|x_1x_2) \left[ \sum_{i_1, i_2, j, a_1, a_2} P(x_1x_2j|i_1i_2y) e_1(i_1|a_1) e_2(i_2|a_2) d(a_1 a_2 | j) \right] \geq 1 - \varepsilon.$$

Define  $\hat{P}(x_1x_2(b_1b_2)|a_1a_2y) := \sum_{i_1, i_2, j} P(x_1x_2j|i_1i_2y) e_1(i_1|a_1) e_2(i_2|a_2) d(b_1b_2|j)$ . One can easily check that  $\hat{P}$  is non-signaling, and thus:

$$S^{\text{NS}}(W^{\otimes N}, \ell_1, \ell_2) \geq \frac{1}{\ell_1 \ell_2} \sum_{x_1, x_2, y} W(y|x_1x_2) \sum_{a_1, a_2} \hat{P}(x_1x_2(a_1, a_2)|a_1a_2y) \geq 1 - \varepsilon.$$

This implies that  $\lim_{n \rightarrow +\infty} S^{\text{NS}}(W^{\otimes n}, [2^{R_1 n}], [2^{R_2 n}]) = 1$ , i.e.  $(R_1, R_2) \in \mathcal{C}^{\text{NS}}(W)$ .  $\square$

Thanks to Proposition 4.19, we have for any non-signaling assisted code  $P$ ,  $\mathcal{C}(W^{\otimes n}[P]) \subseteq \mathcal{C}^{\text{NS}}(W^{\otimes n})$ . But if  $(R_1, R_2) \in \mathcal{C}^{\text{NS}}(W^{\otimes n})$ , we have that  $(\frac{R_1}{n}, \frac{R_2}{n}) \in \mathcal{C}^{\text{NS}}(W)$ . Thus, applying Theorem 4.1 on  $W^{\otimes n}[P]$  leads to inner bounds on  $\mathcal{C}^{\text{NS}}(W)$ :

**Proposition 4.20** (Inner Bounds on  $\mathcal{C}^{\text{NS}}(W)$ ). *For any number of copies  $n$ , number of inputs  $k_1 \in [|\mathcal{X}_1|^n]$  and  $k_2 \in [|\mathcal{X}_2|^n]$ , non-signaling assisted codes  $P$  on inputs in  $[k_1], [k_2]$  for  $W^{\otimes n}$ , and distributions  $q_1, q_2$  on  $[k_1], [k_2]$ , we have that the rate pairs  $(R_1, R_2)$  satisfying the following constraints are in  $\mathcal{C}^{\text{NS}}(W)$ :*

$$R_1 \leq \frac{I(I_1 : J|I_2)}{n}, \quad R_2 \leq \frac{I(I_2 : J|I_1)}{n}, \quad R_1 + R_2 \leq \frac{I((I_1, I_2) : J)}{n},$$

for  $(I_1, I_2) \in [k_1] \times [k_2]$  following the product law  $q_1 \times q_2$ , and  $J \in [\ell]$  the outcome of  $W^{\otimes n}[P]$  on inputs  $I_1, I_2$ . In particular, the corner points of this capacity region are given by:

$$\left( \frac{I(I_1 : J|I_2)}{n}, \frac{I(I_2 : J)}{n} \right) \quad \text{and} \quad \left( \frac{I(I_1 : J)}{n}, \frac{I(I_2 : J|I_1)}{n} \right).$$

*Proof.* The achievable region comes from the previous discussion. We just need to prove that the corner points are of the given form. If  $R_1 = \frac{I(I_1 : J|I_2)}{n}$ , constraints on  $R_2$  and  $R_1 + R_2$  leads to a maximum  $R_2 = \min\left(\frac{I(I_2 : J|I_1)}{n}, \frac{I((I_1, I_2) : J)}{n} - \frac{I(I_1 : J|I_2)}{n}\right)$ . However,  $I((I_1, I_2) : J) - I(I_1 : J|I_2) = I(I_2 : J)$  by the chain rule. We only need to show that  $I(I_2 : J) \leq I(I_2 : J|I_1)$  and the proof will be complete, since the other corner point is symmetric. We have:

$$\begin{aligned} I(I_2 : J) &= H(I_2) - H(I_2|J) = H(I_2|I_1) - H(I_2|J) \\ &\leq H(I_2|I_1) - H(I_2|JI_1) = I(I_2 : J|I_1), \end{aligned} \quad (4.49)$$

the second equality coming from the fact that  $I_1$  and  $I_2$  are independent, and the inequality coming from the fact that  $H(A|BC) \leq H(A|B)$  for any  $A, B, C$ .  $\square$

**Application to the Noisy Binary Adder Channel** We will now apply this strategy to a noisy version of the BAC. We will consider flip errors  $\varepsilon_1, \varepsilon_2$  of inputs  $x_1, x_2$  on  $W_{\text{BAC}}$ , which leads to the following definition of  $W_{\text{BAC}, \varepsilon_1, \varepsilon_2}$ :

$$\begin{aligned} \forall y, x_1, x_2, W_{\text{BAC}, \varepsilon_1, \varepsilon_2}(y|x_1 x_2) &:= (1 - \varepsilon_1)(1 - \varepsilon_2)W_{\text{BAC}}(y|x_1 x_2) \\ &\quad + \varepsilon_1(1 - \varepsilon_2)W_{\text{BAC}}(y|\bar{x}_1 x_2) \\ &\quad + (1 - \varepsilon_1)\varepsilon_2 W_{\text{BAC}}(y|x_1 \bar{x}_2) \\ &\quad + \varepsilon_1 \varepsilon_2 W_{\text{BAC}}(y|\bar{x}_1 \bar{x}_2). \end{aligned} \quad (4.50)$$

First, let us note that the zero-error non-signaling assisted capacity region of  $W_{\text{BAC}, \varepsilon_1, \varepsilon_2}$  is trivial for  $\varepsilon \in (0, 1)$ :

**Proposition 4.21.** *If  $\varepsilon_1, \varepsilon_2 \in (0, 1)$ , then  $\mathcal{C}_0^{\text{NS}}(W_{\text{BAC}, \varepsilon_1, \varepsilon_2}) = \{(0, 0)\}$ .*

*Proof.* If  $S^{\text{NS}}(W^{\otimes n}, k_1, k_2) = 1$ , then  $\forall y^n, x_1^n, x_2^n : W^{\otimes n}(y^n | x_1^n x_2^n) > 0 \implies r_{x_1^n, x_2^n, y^n} = p_{x_1^n, x_2^n}$ . Indeed, we have for an optimal  $p, r$  that:

$$\begin{aligned} S^{\text{NS}}(W^{\otimes n}, k_1, k_2) &= \frac{1}{k_1 k_2} \sum_{x_1^n, x_2^n, y^n} W^{\otimes n}(y^n | x_1^n x_2^n) r_{x_1^n, x_2^n, y^n} \\ &\leq \frac{1}{k_1 k_2} \sum_{x_1^n, x_2^n, y^n} W^{\otimes n}(y^n | x_1^n x_2^n) p_{x_1^n, x_2^n} = 1, \end{aligned} \quad (4.51)$$

which implies the previous statement. But, for  $W_{\text{BAC}, \varepsilon_1, \varepsilon_2}^{\otimes n}$ , one can easily check that for all  $y^n, x_1^n, x_2^n$ ,  $W^{\otimes n}(y^n | x_1^n x_2^n) > 0$  since  $\varepsilon_1, \varepsilon_2 \in (0, 1)$ . Indeed, one can flip the inputs to a valid preimage of the output. Thus if  $S^{\text{NS}}(W_{\text{BAC}, \varepsilon_1, \varepsilon_2}^{\otimes n}, k_1, k_2) = 1$ , we have that  $\forall y^n, x_1^n, x_2^n, r_{x_1^n, x_2^n, y^n} = p_{x_1^n, x_2^n}$ . In particular, this implies that  $\sum_{x_1^n, x_2^n} r_{x_1^n, x_2^n, y^n} = \sum_{x_1^n, x_2^n} p_{x_1^n, x_2^n}$ , therefore  $1 = k_1 k_2$ , so  $k_1 = 1$  and  $k_2 = 1$ . Thus  $S^{\text{NS}}(W^{\otimes n}, 2^{nR_1}, 2^{nR_2}) = 1$  implies that  $(R_1, R_2) = (0, 0)$ .  $\square$

We have then applied the numerical method described in Proposition 4.20 to  $W_{\text{BAC}, \varepsilon_1, \varepsilon_2}$  for the symmetric case  $\varepsilon_1 = \varepsilon_2 = \varepsilon := 10^{-3}$ . Since it is hard to go through all non-signaling assisted codes  $P$  and product distributions  $q_1, q_2$ , we have applied the heuristic of using non-signaling assisted codes obtained while optimizing  $S^{\text{NS}}(W^{\otimes n}, k_1, k_2)$  in the symmetrized linear program. We have combined them with uniform  $q_1, q_2$ , as the form of those non-signaling assisted codes coming from our optimization program is symmetric. We have evaluated the achievable corner points for all  $k_1, k_2 \leq 2^n$  for  $n \leq 5$  copies which led to Figure 4.5: Compared to the noiseless binary adder channel, we can first notice that the classical capacity region is slightly smaller, with a classical sum-rate capacity of 1.478 at most. On the other hand, although the zero-error non-signaling assisted capacity of  $W_{\text{BAC}, \varepsilon, \varepsilon}$  is completely trivial, we have with our concatenated codes strategy found significant rate pairs achievable with non-signaling assistance. In particular, we have reached a non-signaling assisted sum-rate capacity of 1.493 which beats the best classical sum-rate capacity. Thus, it shows that non-signaling assistance can improve the capacity of the noisy binary adder channel as well.

## 4.5 Relaxed Non-Signaling Assisted Capacity Region and Outer Bounds

A natural question that arises when studying the strength of non-signaling assistance is whether a result similar to Theorem 4.1 can be found to describe by a single-letter formula the non-signaling assisted capacity region of MACs. In particular, dropping the constraint that  $(X_1, X_2)$  is in product form in Theorem 4.1 seems to be a particularly good candidate to characterize the non-signaling assisted capacity region of MACs, as this looks quite similar to allowing correlations between parties.

We have not been able to show the equivalence between this region and the non-signaling assisted capacity region; however, it turns out to be equivalent to the capacity region defined by a slight relaxation of non-signaling assistance, which we call  $S^{\text{NS}}(W, k_1, k_2)$ . In particular, this will give us the best known outer bound on the non-signaling capacity.



#### 4.5. Relaxed Non-Signaling Assisted Capacity Region and Outer Bounds

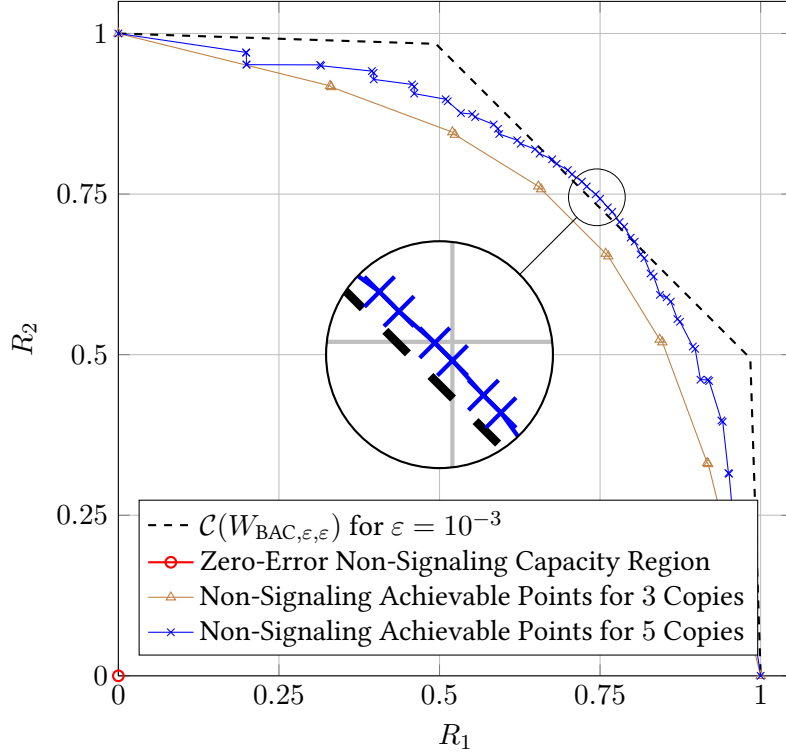

Figure 4.5 – Capacity regions of the noisy binary adder channel  $W_{\text{BAC},\varepsilon,\varepsilon}$  for  $\varepsilon = 10^{-3}$ . The black dashed curve depicts the classical capacity region  $\mathcal{C}(W_{\text{BAC},\varepsilon,\varepsilon})$  which was found numerically using Theorem 4.1. The red point depicts the zero-error non-signaling assisted capacity region (Proposition 4.21). The blue curve depicts achievable non-signaling assisted rates pairs obtained from  $\mathcal{C}(W_{\text{BAC},\varepsilon,\varepsilon}^{\otimes 5}[P])$  through the numerical method described in Proposition 4.20.

**Definition 4.4.**

$$\begin{aligned}
 S^{\overline{\text{NS}}}(W, k_1, k_2) := & \underset{r,p}{\text{maximize}} \quad \frac{1}{k_1 k_2} \sum_{x_1, x_2, y} W(y|x_1 x_2) r_{x_1, x_2, y} \\
 \text{subject to} & \quad \sum_{x_1, x_2} r_{x_1, x_2, y} \leq 1 \\
 & \quad \sum_{x_1, x_2} p_{x_1, x_2} = k_1 k_2 \\
 & \quad \sum_{x_1} p_{x_1, x_2} \geq k_1 \sum_{x_1} r_{x_1, x_2, y} \\
 & \quad \sum_{x_2} p_{x_1, x_2} \geq k_2 \sum_{x_2} r_{x_1, x_2, y} \\
 & \quad 0 \leq r_{x_1, x_2, y} \leq p_{x_1, x_2}
 \end{aligned} \tag{4.52}$$

The following proposition shows that this is indeed a relaxation of the non-signaling constraint.

**Proposition 4.22.**  $S^{\text{NS}}(W, k_1, k_2) \leq S^{\overline{\text{NS}}}(W, k_1, k_2)$ .

*Proof.* Let us take a solution  $(p_{x_1, x_2}, r_{x_1, x_2, y}, r_{x_1, x_2, y}^1, r_{x_1, x_2, y}^2)_{x_1 \in \mathcal{X}_1, x_2 \in \mathcal{X}_2, y \in \mathcal{Y}}$  of the linear program computing  $S^{\text{NS}}(W, k_1, k_2)$ . Let us show that  $(p_{x_1, x_2}, r_{x_1, x_2, y})_{x_1 \in \mathcal{X}_1, x_2 \in \mathcal{X}_2, y \in \mathcal{Y}}$  is a solution of the linear program computing  $S^{\overline{\text{NS}}}(W, k_1, k_2)$  with a same objective value, from which the proposition follows.

They have indeed the same value, since the definition which is the same for both programs depends only on  $r_{x_1, x_2, y}$ . Let us show that all constraints are satisfied for the solution  $(p_{x_1, x_2}, r_{x_1, x_2, y})_{x_1 \in \mathcal{X}_1, x_2 \in \mathcal{X}_2, y \in \mathcal{Y}}$ .

We have  $\sum_{x_1, x_2} r_{x_1, x_2, y} = 1 \leq 1$  so the first constraint is satisfied. We have then that:

$$\sum_{x_1, x_2} p_{x_1, x_2} = k_1 \sum_{x_1, x_2} r_{x_1, x_2, y}^2 = k_1 k_2 \sum_{x_1, x_2} r_{x_1, x_2, y} = k_1 k_2,$$

so the second constraint is satisfied.

For the third constraint (and symmetrically the fourth constraint), we have:

$$\sum_{x_1} p_{x_1, x_2} = k_1 \sum_{x_1} r_{x_1, x_2, y}^2 \geq k_1 \sum_{x_1} r_{x_1, x_2, y}.$$

Finally, we have directly  $0 \leq r_{x_1, x_2, y} \leq p_{x_1, x_2}$ , so the last constraint is satisfied.  $\square$

We can now define the relaxed non-signaling assisted capacity region of a MAC  $W$  using Definition 2.12 by  $\mathcal{C}^{\overline{\text{NS}}}(W) := \mathcal{C}[S^{\overline{\text{NS}}}] (W)$ .

**Proposition 4.23.**  $\mathcal{C}^{\overline{\text{NS}}}(W)$  is convex.

*Proof.* We only need to show that for all MACs  $W, W'$  and integers  $k_1, k_2, k'_1, k'_2$ :

$$S^{\overline{\text{NS}}}(W \otimes W', k_1 k'_1, k_2 k'_2) \geq S^{\overline{\text{NS}}}(W, k_1, k_2) \cdot S^{\overline{\text{NS}}}(W', k'_1, k'_2),$$

thanks to Proposition 2.15. Let us consider optimal solutions  $(p_{x_1, x_2}, r_{x_1, x_2, y})_{x_1 \in \mathcal{X}_1, x_2 \in \mathcal{X}_2, y \in \mathcal{Y}}$  and  $(p'_{x'_1, x'_2}, r'_{x'_1, x'_2, y'})_{x'_1 \in \mathcal{X}'_1, x'_2 \in \mathcal{X}'_2, y' \in \mathcal{Y}'}$  of the programs computing  $S^{\overline{\text{NS}}}(W, k_1, k_2)$  and  $S^{\overline{\text{NS}}}(W', k'_1, k'_2)$  respectively. We construct a solution of the program computing the success probability  $S^{\overline{\text{NS}}}(W \otimes W', k_1 k'_1, k_2 k'_2)$  by defining:

$$p_{x_1 x'_1, x_2 x'_2}^* := p_{x_1, x_2} p'_{x'_1, x'_2} \text{ and } r_{x_1 x'_1, x_2 x'_2, y y'}^* := r_{x_1, x_2, y} r'_{x'_1, x'_2, y'},$$

as  $W \otimes W' : (\mathcal{X}_1 \times \mathcal{X}'_1) \times (\mathcal{X}_2 \times \mathcal{X}'_2) \rightarrow (\mathcal{Y} \times \mathcal{Y}')$ . It is straightforward to check that it is a valid solution. Indeed, linear constraints are preserved by product, except for coefficients  $k_1, k_2$  which are replaced by products  $k_1 k'_1$  and  $k_2 k'_2$ . Therefore, we have that  $S^{\overline{\text{NS}}}(W \otimes W', k_1 k'_1, k_2 k'_2)$  is larger than or equal to:

$$\begin{aligned} & \frac{1}{k_1 k'_1 k_2 k'_2} \sum_{x_1, x'_1, x_2, x'_2, y, y'} (W \otimes W') (y y' | x_1 x'_1 x_2 x'_2) r_{x_1 x'_1, x_2 x'_2, y y'}^* \\ &= \frac{1}{k_1 k'_1 k_2 k'_2} \sum_{x_1, x'_1, x_2, x'_2, y, y'} W(y | x_1 x_2) W'(y' | x'_1 x'_2) r_{x_1, x_2, y} r'_{x'_1, x'_2, y'} \\ &= \left( \frac{1}{k_1 k_2} \sum_{x_1, x_2, y} W(y | x_1 x_2) r_{x_1, x_2, y} \right) \cdot \left( \frac{1}{k'_1 k'_2} \sum_{x'_1, x'_2, y'} W'(y' | x'_1 x'_2) r'_{x'_1, x'_2, y'} \right) \\ &= S^{\overline{\text{NS}}}(W, k_1, k_2) \cdot S^{\overline{\text{NS}}}(W', k'_1, k'_2). \end{aligned} \tag{4.53}$$

□

A direct property that follows from this definition and Proposition 4.22 is the fact that the non-signaling assisted capacity region is included in the relaxed non-signaling assisted capacity region.

**Corollary 4.24.**  $\mathcal{C}^{\text{NS}}(W) \subseteq \overline{\mathcal{C}^{\text{NS}}}(W)$ .

We present now the main result of this section, the characterization of  $\overline{\mathcal{C}^{\text{NS}}}(W)$  by a single-letter formula.

**Theorem 4.25** (Characterization of  $\overline{\mathcal{C}^{\text{NS}}}(W)$ ).  $\overline{\mathcal{C}^{\text{NS}}}(W)$  is the closure of the convex hull of all rate pairs  $(R_1, R_2)$  satisfying:

$$R_1 < I(X_1 : Y|X_2), R_2 < I(X_2 : Y|X_1), R_1 + R_2 < I((X_1, X_2) : Y),$$

for  $(X_1, X_2)$  following some law  $P_{X_1 X_2}$  on  $\mathcal{X}_1 \times \mathcal{X}_2$ , and  $Y \in \mathcal{Y}$  the outcome of  $W$  on inputs  $X_1, X_2$ .

*Remark.* Note that the only difference with the classical capacity region of MACs in Theorem 4.1 is that the joint distribution of  $X_1$  and  $X_2$  does not have a product form constraint here.

The proof of Theorem 4.25 will be divided in Proposition 4.31 (outer bound part) and Proposition 4.33 (achievability part). But first, let us apply these results to the binary adder channel.

**Application to the Binary Adder Channel** Let us determine the relaxed non-signaling assisted capacity of the binary adder channel which will be plotted in Figure 4.6.

**Proposition 4.26.**  $\overline{\mathcal{C}^{\text{NS}}}(W_{\text{BAC}})$  has the following description:

$$\overline{\mathcal{C}^{\text{NS}}}(W_{\text{BAC}}) = \bigcup_{q \in [\frac{1}{2}, \frac{2}{3}]} \{(R_1, R_2) : R_1 \leq h(q), R_2 \leq h(q), R_1 + R_2 \leq q + h(q)\}.$$

*Remark.* Note that for  $q = \frac{1}{2}$ , the bound becomes  $R_1 \leq 1, R_2 \leq 1, R_1 + R_2 \leq \frac{3}{2}$  and when  $q = \frac{2}{3}$  the bound becomes  $R_1 \leq \log_2(3) - \frac{2}{3}, R_2 \leq \log_2(3) - \frac{2}{3}, R_1 + R_2 \leq \log_2(3)$ .

*Proof.* We use the characterization of  $\overline{\mathcal{C}^{\text{NS}}}$  provided by Theorem 4.25.

Let us consider an arbitrary  $P_{X_1 X_2} = (p_{00}, p_{01}, p_{10}, p_{11})$ . First, we have that  $I((X_1, X_2) : Y) = H(Y) - H(Y|X_1 X_2) = H(Y)$  since  $Y$  is a deterministic function of  $(X_1, X_2)$ . Then, we have that  $I(X_1 : Y|X_2) = H(Y|X_2) - H(Y|X_1 X_2) = H(Y|X_2)$  for the same reason. Furthermore, given  $X_2$ ,  $Y$  is a deterministic function of  $X_1$ , so we have  $I(X_1 : Y|X_2) = H(Y|X_2) - H(Y|X_1 X_2) = H(X_1|X_2)$ . Symmetrically we have as well  $I(X_2 : Y|X_1) = H(X_2|X_1)$ . In all,  $\overline{\mathcal{C}^{\text{NS}}}(W_{\text{BAC}})$  is equal to:

$$\bigcup_{P_{X_1 X_2}} \{(R_1, R_2) : R_1 \leq H(X_1|X_2), R_2 \leq H(X_2|X_1), R_1 + R_2 \leq H(X_1 + X_2)\}.$$

Let us call  $B_1(P_{X_1X_2}) := H(X_1|X_2)$ ,  $B_2(P_{X_1X_2}) := H(X_2|X_1)$  and  $B_{12}(P_{X_1X_2}) := H(X_1 + X_2)$  the three bounds. Let us call  $P_{\bar{X}_1\bar{X}_2} = (p_{11}, p_{10}, p_{01}, p_{00})$ . One can notice that:

$$\begin{aligned} B_1(P_{\bar{X}_1\bar{X}_2}) &= H(\bar{X}_1|\bar{X}_2) = H(1 - X_1|1 - X_2) = H(X_1|X_2) = B_1(P_{X_1X_2}), \\ B_2(P_{\bar{X}_1\bar{X}_2}) &= H(1 - X_2|1 - X_1) = H(X_2|X_1) = B_2(P_{X_1X_2}), \\ B_{12}(P_{\bar{X}_1\bar{X}_2}) &= H(\bar{X}_1 + \bar{X}_2) = H(1 - X_1 + 1 - X_2) \\ &= H(2 - (X_1 + X_2)) = H(X_1 + X_2) = B_{12}(P_{X_1X_2}). \end{aligned} \quad (4.54)$$

Since  $B_{12}(P_{X_1X_2}) = H(X_1 + X_2) = H(p_{00}, p_{11}, p_{01} + p_{10})$ , it is concave in  $P_{X_1X_2}$  as  $H$  is concave and  $(p_{00}, p_{11}, p_{01} + p_{10})$  is linear in  $P_{X_1X_2}$ . Also,  $B_1(P_{X_1X_2}) = H(X_1|X_2) = -D(P_{X_1X_2}||I \otimes P_{X_2})$  is concave in  $P_{X_1X_2}$  as the divergence  $D$  is jointly convex and  $I \otimes P_{X_2}$  is linear in  $P_{X_1X_2}$ . By symmetry,  $B_2(P_{X_1X_2})$  is as well concave in  $P_{X_1X_2}$ . Let us consider any of those three bounds, which we call  $B$ . We have by concavity of  $B$  and the fact that  $B(P_{X_1X_2}) = B(P_{\bar{X}_1\bar{X}_2})$ :

$$\begin{aligned} B(P_{X_1X_2}) &= \frac{B(P_{X_1X_2}) + B(P_{\bar{X}_1\bar{X}_2})}{2} \leq B\left(\frac{P_{X_1X_2} + P_{\bar{X}_1\bar{X}_2}}{2}\right) \\ &= B\left(\frac{q}{2}, \frac{1-q}{2}, \frac{1-q}{2}, \frac{q}{2}\right), \end{aligned} \quad (4.55)$$

with  $q = p_{00} + p_{11}$ . This holds for the three bounds at the same time, so we can restrict ourselves to the distributions of the form  $\left(\frac{q}{2}, \frac{1-q}{2}, \frac{1-q}{2}, \frac{q}{2}\right)$  for some  $q \in [0, 1]$ , i.e.,  $P_{X_1X_2}(0, 0) = P_{X_1X_2}(1, 1) = \frac{q}{2}$  and  $P_{X_1X_2}(0, 1) = P_{X_1X_2}(1, 0) = \frac{1-q}{2}$ .

We have  $P_Y(0) = P_Y(2) = \frac{q}{2}$  and  $P_Y(1) = 1 - q$ , so:

$$\begin{aligned} B_{12}(P_{X_1X_2}) &= H(Y) = -q \log\left(\frac{q}{2}\right) - (1 - q) \log(1 - q) \\ &= -q (\log(q) - 1) - (1 - q) \log(1 - q) \\ &= q + h(q). \end{aligned} \quad (4.56)$$

We have  $P_{X_2}(0) = P_{X_1X_2}(0, 0) + P_{X_1X_2}(1, 0) = \frac{q}{2} + \frac{1-q}{2} = \frac{1}{2}$  so  $P_{X_2}(1) = \frac{1}{2}$ . Thus:

$$B_1(P_{X_1X_2}) = H(X_1|X_2) = \frac{1}{2}H(X_1|X_2 = 0) + \frac{1}{2}H(X_1|X_2 = 1).$$

We have  $P_{X_1|X_2=0}(0) = \frac{P_{X_1X_2}(0,0)}{P_{X_2}(0)} = q$  so  $H(X_1|X_2 = 0) = h(q)$ . On the other hand, we have  $P_{X_1|X_2=1}(1) = \frac{P_{X_1X_2}(1,1)}{P_{X_2}(1)} = q$  so we get as well  $H(X_1|X_2 = 1) = h(q)$ , and  $B_1(P_{X_1X_2}) = H(X_1|X_2) = h(q)$ . Symmetrically, we also get  $B_2(P_{X_1X_2}) = h(q)$ . Therefore, we get that  $\mathcal{C}^{\text{NS}}(W_{\text{BAC}})$  is the closure of the convex hull of:

$$\bigcup_{q \in [0,1]} \{(R_1, R_2) : R_1 < h(q), R_2 < h(q), R_1 + R_2 < q + h(q)\}.$$

However this set is already convex, so we have:

$$\mathcal{C}^{\text{NS}}(W_{\text{BAC}}) = \bigcup_{q \in [0,1]} \{(R_1, R_2) : R_1 \leq h(q), R_2 \leq h(q), R_1 + R_2 \leq q + h(q)\}.$$

Finally, we can restrict ourselves to  $q \in \left[\frac{1}{2}, \frac{2}{3}\right]$ , since  $h$  is increasing from 0 to  $\frac{1}{2}$  (thus  $q \mapsto q + h(q)$  as well), and the fact that  $q \mapsto q + h(q)$  achieves its maximum for  $q = \frac{2}{3}$  with  $\frac{2}{3} + h\left(\frac{2}{3}\right) = \log_2(3)$  and then decreases (whereas  $h$  is decreasing from  $\frac{1}{2}$  to 1), which completes the proof.  $\square$

As before, one can also define a symmetrized version of the relaxed linear program computing the value  $S^{\overline{\text{NS}}}(W^{\otimes n}, k_1, k_2)$  in polynomial time in  $n$  and compute the zero-error  $n$ -shots capacity region by looking at the rates where  $S^{\overline{\text{NS}}}(W^{\otimes n}, k_1, k_2) = 1$ . We have computed this up to 7 copies of the binary adder channel, which led to Figure 4.6:

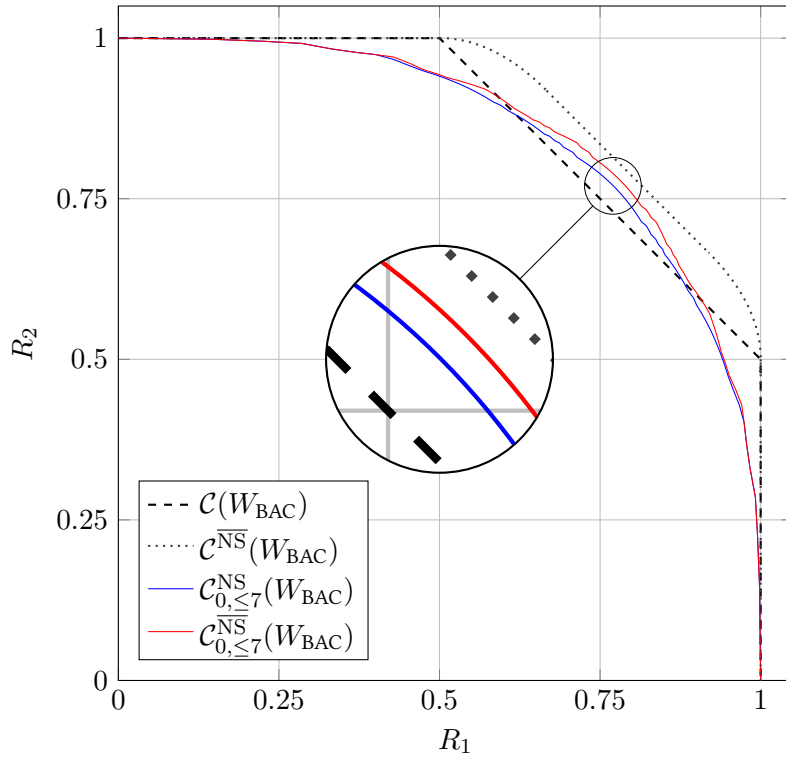

Figure 4.6 – Comparison of relaxed and regular non-signaling assisted capacity regions of the binary adder channel. The black dashed curve depicts the classical capacity region  $\mathcal{C}(W_{\text{BAC}})$ , whereas the grey dotted curve depicts the relaxed non-signaling assisted capacity region  $\mathcal{C}^{\overline{\text{NS}}}(W_{\text{BAC}})$  as described in Proposition 4.26. In particular, the curved corners are obtained by taking  $R_1 = h(R_2)$  for  $R_2 \in \left[\frac{1}{2}, \frac{2}{3}\right]$  and symmetrically by switching the roles played by  $R_1$  and  $R_2$ . The continuous blue (respectively red) curve depicts the zero-error (respectively relaxed) non-signaling assisted achievable rate pairs for 7 copies of the binary adder channel.

The first noticeable result coming from these curves is that the values  $S^{\overline{\text{NS}}}$  and  $S^{\text{NS}}$  differ. While the highest sum-rate of  $\frac{2 \log_2(42)}{7} \simeq 1.5406$  is achieved on 7 copies of the binary adder channel with zero-error and non-signaling assistance, coming from the fact that  $S^{\text{NS}}(W_{\text{BAC}}^{\otimes 7}, 42, 42) = 1$ , we have that  $S^{\overline{\text{NS}}}(W_{\text{BAC}}^{\otimes 7}, 44, 44) = 1 > S^{\text{NS}}(W_{\text{BAC}}^{\otimes 7}, 44, 44) \simeq$

0.9581 which implies that a sum-rate of  $\frac{2 \log_2(44)}{7} \simeq 1.5598$  is achieved on 7 copies of the binary adder channel with zero-error and relaxed non-signaling assistance. It also largely beats the best found sum-rate of  $\frac{\log_2(72)}{4} \simeq 1.5425$  achieved on 8 copies with the regular version. However the fact that the non-signaling assisted capacity region is strictly contained in the relaxed one is still open, as the same rates could potentially be achieved by the cost of using more copies of the channel.

#### 4.5.1 Outer Bound Part of Theorem 4.25

In order to prove Proposition 4.31, we use a connection between hypothesis testing and relaxed non-signaling assisted codes as established in [Mat12] for point-to-point channels.

**Definition 4.5** (Hypothesis Testing). Given distributions  $P^{(0)}$  and  $P^{(1)}$  on the same space  $C$ , we define  $\beta_{1-\varepsilon}(P^{(0)}, P^{(1)})$  to be the minimum type II error  $\sum_{r \in C} T_r P^{(1)}(r)$  that can be achieved by statistical tests  $T$  which give a type I error no greater than  $\varepsilon$ , i.e.  $\sum_{r \in C} T_r P^{(0)}(r) \geq 1 - \varepsilon$ .

In other words, we have that:

$$\begin{aligned} \beta_{1-\varepsilon}(P^{(0)}, P^{(1)}) = & \underset{T_r}{\text{minimize}} && \sum_{r \in C} T_r P^{(1)}(r) \\ & \text{subject to} && \sum_{r \in C} T_r P^{(0)}(r) \geq 1 - \varepsilon \\ & && 0 \leq T_r \leq 1. \end{aligned} \quad (4.57)$$

**Lemma 4.27.** For any relaxed non-signaling assisted code  $(p_{x_1, x_2}, r_{x_1, x_2, y})_{x_1 \in \mathcal{X}_1, x_2 \in \mathcal{X}_2, y \in \mathcal{Y}}$  with  $(k_1, k_2)$  messages and a probability of success  $1 - \varepsilon$ , if  $P_{X_1 X_2}(x_1, x_2) = \frac{p_{x_1, x_2}}{k_1 k_2}$  and  $Y \in \mathcal{Y}$  is the outcome of  $W$  on inputs  $X_1, X_2$ , we have:

$$\begin{aligned} \beta_{1-\varepsilon}(P_{X_1 X_2 Y}, P_{X_1 X_2} \times P_{Y|X_2}) &\leq \frac{1}{k_1} \\ \beta_{1-\varepsilon}(P_{X_1 X_2 Y}, P_{X_1 X_2} \times P_{Y|X_1}) &\leq \frac{1}{k_2} \\ \beta_{1-\varepsilon}(P_{X_1 X_2 Y}, P_{X_1 X_2} \times P_Y) &\leq \frac{1}{k_1 k_2}. \end{aligned} \quad (4.58)$$

*Remark.* These three bounds are actually achieved with the same statistical test.

*Proof.* This result is a direct generalization of Theorem 9 in [Mat12] for point-to-point channels, itself a generalization of Theorem 27 in [PPV10] without non-signaling assistance.

Let us name  $W_0 := W$  and  $W_1$  a MAC yet to be defined. The coding strategy described by  $r_{x_1, x_2, y}$  and  $p_{x_1, x_2}$  leads to a probability of success on channel  $i \in \{0, 1\}$  given by:

$$\begin{aligned} 1 - \varepsilon_i &= \frac{1}{k_1 k_2} \sum_{x_1, x_2, y} r_{x_1, x_2, y} W_i(y|x_1 x_2) \\ &= \sum_{x_1, x_2, y: p_{x_1, x_2} > 0} \frac{r_{x_1, x_2, y}}{p_{x_1, x_2}} W_i(y|x_1 x_2) \frac{p_{x_1, x_2}}{k_1 k_2} \quad \text{since } 0 \leq r_{x_1, x_2, y} \leq p_{x_1, x_2} \\ &= \sum_{x_1, x_2, y} T_{x_1, x_2, y} W_i(y|x_1 x_2) \frac{p_{x_1, x_2}}{k_1 k_2}, \end{aligned} \quad (4.59)$$

---

#### 4.5. Relaxed Non-Signaling Assisted Capacity Region and Outer Bounds

with  $T_{x_1, x_2, y} := \frac{r_{x_1, x_2, y}}{p_{x_1, x_2}}$  if  $p_{x_1, x_2} > 0$ , and  $T_{x_1, x_2, y} := 0$  otherwise.

If now  $Y$  is the output of the channel  $W_i$ , the joint distribution of  $X_1, X_2, Y$  is given by  $P_{X_1 X_2 Y}^{(i)}(x_1, x_2, y) = W_i(y|x_1 x_2) P_{X_1 X_2}(x_1, x_2) = W_i(y|x_1 x_2) \frac{p_{x_1, x_2}}{k_1 k_2}$ .

On the other hand, we have that for all  $x_1, x_2, y$ ,  $0 \leq T_{x_1, x_2, y} \leq 1$  since  $0 \leq r_{x_1, x_2, y} \leq p_{x_1, x_2}$ . So we get that:

$$1 - \varepsilon_i = \sum_{x_1, x_2, y} T_{x_1, x_2, y} P_{X_1 X_2 Y}^{(i)}(x_1, x_2, y).$$

Since  $\sum_{x_1, x_2, y} T_{x_1, x_2, y} P_{X_1 X_2 Y}^{(0)}(x_1, x_2, y) \geq 1 - \varepsilon_0$  and  $0 \leq T_{x_1, x_2, y} \leq 1$ , we have:

$$\beta_{1-\varepsilon_0}(P^{(0)}, P^{(1)}) \leq \sum_{x_1, x_2, y} T_{x_1, x_2, y} P_{X_1 X_2 Y}^{(1)}(x_1, x_2, y) = 1 - \varepsilon_1.$$

Let us now consider three general cases, depending on the fact that  $W_1$  does not depend on  $x_1, x_2$  or both:  $W_1(y|x_1 x_2) := Q^{(1)}(y|x_2)$ ;  $W_1(y|x_1 x_2) := Q^{(2)}(y|x_1)$ ;  $W_1(y|x_1 x_2) := Q^{(0)}(y)$ . These will give respectively the three bounds we want.

First, let us consider the case where  $W_1(y|x_1 x_2) := Q^{(1)}(y|x_2)$  (the second case where  $W_1(y|x_1 x_2) := Q^{(2)}(y|x_1)$  being symmetric), we have that:

$$\begin{aligned} 1 - \varepsilon_1 &= \sum_{x_1, x_2, y} T_{x_1, x_2, y} Q^{(1)}(y|x_2) \frac{p_{x_1, x_2}}{k_1 k_2} = \frac{1}{k_1 k_2} \sum_{x_2, y} Q^{(1)}(y|x_2) \sum_{x_1} T_{x_1, x_2, y} p_{x_1, x_2} \\ &= \frac{1}{k_1 k_2} \sum_{x_2, y} Q^{(1)}(y|x_2) \sum_{x_1} r_{x_1, x_2, y} \leq \frac{1}{k_1 k_2} \sum_{x_2, y} Q^{(1)}(y|x_2) \frac{1}{k_1} \sum_{x_1} p_{x_1, x_2} \\ &= \frac{1}{k_1} \sum_{x_1, x_2} \frac{p_{x_1, x_2}}{k_1 k_2} \sum_y Q^{(1)}(y|x_2) = \frac{1}{k_1} \sum_{x_1, x_2} \frac{p_{x_1, x_2}}{k_1 k_2} = \frac{1}{k_1}. \end{aligned} \tag{4.60}$$

For the third case, when  $W_1(y|x_1 x_2) := Q^{(0)}(y)$ , we have:

$$\begin{aligned} 1 - \varepsilon_1 &= \sum_{x_1, x_2, y} T_{x_1, x_2, y} Q^{(0)}(y) \frac{p_{x_1, x_2}}{k_1 k_2} = \frac{1}{k_1 k_2} \sum_y Q^{(0)}(y) \sum_{x_1, x_2} T_{x_1, x_2, y} p_{x_1, x_2} \\ &= \frac{1}{k_1 k_2} \sum_y Q^{(0)}(y) \sum_{x_1, x_2} r_{x_1, x_2, y} \leq \frac{1}{k_1 k_2} \sum_y Q^{(0)}(y) = \frac{1}{k_1 k_2}. \end{aligned} \tag{4.61}$$

In those three cases, we have respectively  $P_{X_1 X_2 Y}^{(1)} = P_{X_1 X_2} \times Q_{Y|X_2}^{(1)}$ ;  $P_{X_1 X_2} \times Q_{Y|X_1}^{(2)}$ ; and  $P_{X_1 X_2} \times Q_Y^{(0)}$ . Specializing those cases with  $Q_{Y|X_2}^{(1)} := P_{Y|X_2}$ ;  $Q_{Y|X_1}^{(2)} := P_{Y|X_1}$ ;  $Q_Y^{(0)} := P_Y$  and using the fact that  $\beta_{1-\varepsilon_0}(P^{(0)}, P^{(1)}) \leq 1 - \varepsilon_1$  concludes the proof.  $\square$

**Lemma 4.28.** *For any relaxed non-signaling assisted code  $(p_{x_1, x_2}, r_{x_1, x_2, y})_{x_1 \in \mathcal{X}_1, x_2 \in \mathcal{X}_2, y \in \mathcal{Y}}$  with  $(k_1, k_2)$  messages and a probability of success  $1 - \varepsilon$ , if  $P_{X_1 X_2}(x_1, x_2) = \frac{p_{x_1, x_2}}{k_1 k_2}$  and  $Y \in \mathcal{Y}$  is the outcome of  $W$  on inputs  $X_1, X_2$ , we have:*

$$\begin{aligned} \log(k_1) &\leq \frac{I(X_1 : Y|X_2) + h(\varepsilon)}{1 - \varepsilon}, \\ \log(k_2) &\leq \frac{I(X_2 : Y|X_1) + h(\varepsilon)}{1 - \varepsilon}, \\ \log(k_1) + \log(k_2) &\leq \frac{I((X_1, X_2) : Y) + h(\varepsilon)}{1 - \varepsilon}. \end{aligned} \tag{4.62}$$

*Proof.* Thanks to Lemma 4.27, with the fact that  $P_{X_1X_2} = P_{X_1|X_2} \times P_{X_2} = P_{X_2|X_1} \times P_{X_1}$ , we have already:

$$\begin{aligned} \beta_{1-\varepsilon} \left( P_{X_1X_2Y}, \left( P_{X_1|X_2} \times P_{Y|X_2} \right) \times P_{X_2} \right) &\leq \frac{1}{k_1}, \\ \beta_{1-\varepsilon} \left( P_{X_1X_2Y}, \left( P_{X_2|X_1} \times P_{Y|X_1} \right) \times P_{X_1} \right) &\leq \frac{1}{k_2}, \\ \beta_{1-\varepsilon} \left( P_{X_1X_2Y}, P_{X_1X_2} \times P_Y \right) &\leq \frac{1}{k_1k_2}. \end{aligned} \quad (4.63)$$

Following the steps of section G in [PPV10], since any hypothesis test is a binary-output transformation, by data-processing inequality for divergence, we have that:

$$\begin{aligned} &d \left( 1 - \varepsilon \parallel \beta_{1-\varepsilon} \left( P_{X_1X_2Y}, \left( P_{X_1|X_2} \times P_{Y|X_2} \right) \times P_{X_2} \right) \right) \\ &= d \left( \beta_{1-\varepsilon} \left( P_{X_1X_2Y}, P_{X_1X_2Y} \right) \parallel \beta_{1-\varepsilon} \left( P_{X_1X_2Y}, \left( P_{X_1|X_2} \times P_{Y|X_2} \right) \times P_{X_2} \right) \right) \\ &\leq D \left( P_{X_1X_2Y} \parallel \left( P_{X_1|X_2} \times P_{Y|X_2} \right) \times P_{X_2} \right) = I(X_1 : Y|X_2), \end{aligned} \quad (4.64)$$

where the binary divergence is defined by  $d(a||b) := a \log \left( \frac{a}{b} \right) + (1-a) \log \left( \frac{1-a}{1-b} \right)$  and satisfies  $d(a||b) \geq -h(a) - a \log(b)$ , and thus:

$$\log \left( \frac{1}{b} \right) \leq \frac{d(a||b) + h(a)}{a} = \frac{d(a||b) + h(1-a)}{a}.$$

This leads to:

$$\log(k_1) \leq \frac{1}{\log \left( \beta_{1-\varepsilon} \left( P_{X_1X_2Y}, \left( P_{X_1|X_2} \times P_{Y|X_2} \right) \times P_{X_2} \right) \right)} \leq \frac{I(X_1 : Y|X_2) + h(\varepsilon)}{1 - \varepsilon}.$$

Similarly for the two other inequalities, since  $D \left( P_{X_1X_2Y} \parallel \left( P_{X_2|X_1} \times P_{Y|X_1} \right) \times P_{X_1} \right) = I(X_2 : Y|X_1)$  and  $D \left( P_{X_1X_2Y} \parallel P_{X_1X_2} \times P_Y \right) = I((X_1, X_2) : Y)$ , we get:

$$\begin{aligned} \log(k_1) &\leq \frac{I(X_1 : Y|X_2) + h(\varepsilon)}{1 - \varepsilon}, \\ \log(k_2) &\leq \frac{I(X_2 : Y|X_1) + h(\varepsilon)}{1 - \varepsilon}, \\ \log(k_1) + \log(k_2) &\leq \frac{I((X_1, X_2) : Y) + h(\varepsilon)}{1 - \varepsilon}. \end{aligned} \quad (4.65)$$

□

In order to show additivity of the outer bound, we use the following lemma.

**Lemma 4.29.** *For any distribution  $P_{X_1^n X_2^n}$  of  $(X_1^n, X_2^n)$ , if  $Y^n \in \mathcal{Y}^n$  is the outcome of  $W^n$  on inputs  $X_1^n, X_2^n$ , we have:*

$$\begin{aligned} I(X_1^n : Y^n | X_2^n) &\leq \sum_{i=1}^n I(X_{1,i} : Y_i | X_{2,i}) \\ I(X_2^n : Y^n | X_1^n) &\leq \sum_{i=1}^n I(X_{2,i} : Y_i | X_{1,i}) \\ I((X_1^n, X_2^n) : Y^n) &\leq \sum_{i=1}^n I((X_{1,i}, X_{2,i}) : Y_i). \end{aligned} \quad (4.66)$$



*Proof.* Consider  $n$  copies of  $W$ . Let us write  $X_{1,-i} := X_{1,1} \dots X_{1,i-1} X_{1,i+1} \dots X_{1,n}$  and  $Z^n := Z_1 \dots Z_n$ . We have:

$$\begin{aligned}
 I(X_1^n : Y^n | X_2^n) &= I(X_1^n : Y^n | X_2^n) \\
 &= \sum_{i=1}^n I(X_1^n : Y_i | X_2^n Y^{i-1}) \text{ by the chain rule} \\
 &= \sum_{i=1}^n I(X_{1,i} : Y_i | X_2^n Y^{i-1}) + \sum_{i=1}^n I(X_{1,-i} : Y_i | X_2^n Y^{i-1} X_{1,i}) \\
 &= \sum_{i=1}^n I(X_{1,i} : Y_i | X_2^n Y^{i-1}),
 \end{aligned} \tag{4.67}$$

where the last equality comes from Lemma 4.30. As a result,

$$\begin{aligned}
 I(X_1^n : Y^n | X_2^n) &= \sum_{i=1}^n H(Y_i | X_2^n Y^{i-1}) - H(Y_i | X_2^n Y^{i-1} X_{1,i}) \\
 &= \sum_{i=1}^n H(Y_i | X_2^n Y^{i-1}) - H(Y_i | X_{2,i} X_{1,i}) \\
 &\text{since } X_{2,-i} Y^{i-1} \rightarrow (X_{1,i}, X_{2,i}) \rightarrow Y_i \text{ Markov chain.} \\
 &\leq \sum_{i=1}^n H(Y_i | X_{2,i}) - H(Y_i | X_{2,i} X_{1,i}) = \sum_{i=1}^n I(X_{1,i} : Y_i | X_{2,i}).
 \end{aligned} \tag{4.68}$$

Symmetrically, by switching the roles of  $X_1$  and  $X_2$ , we get the second part of Lemma 4.29. For the sum-rate case:

$$\begin{aligned}
 I((X_1^n, X_2^n) : Y^n) &= \sum_{i=1}^n I((X_1^n, X_2^n) : Y_i | Y^{i-1}) \text{ by the chain rule} \\
 &= \sum_{i=1}^n I((X_{1,i}, X_{2,i}) : Y_i | Y^{i-1}) + \sum_{i=1}^n I((X_{1,-i}, X_{2,-i}) : Y_i | Y^{i-1} X_{1,i} X_{2,i}) \\
 &= \sum_{i=1}^n I((X_{1,i}, X_{2,i}) : Y_i | Y^{i-1}) \\
 &\text{since } (X_{1,-i}, X_{2,-i}) \rightarrow Y^{i-1} X_{1,i} X_{2,i} \rightarrow Y_i \text{ Markov chain.} \\
 &= \sum_{i=1}^n H(Y_i | Y^{i-1}) - H(Y_i | Y^{i-1} X_{1,i} X_{2,i}) \\
 &= \sum_{i=1}^n H(Y_i | Y^{i-1}) - H(Y_i | X_{1,i} X_{2,i}) \text{ since } Y^{i-1} \rightarrow (X_{1,i}, X_{2,i}) \rightarrow Y_i \text{ Markov chain.} \\
 &\leq \sum_{i=1}^n H(Y_i) - H(Y_i | X_{2,i} X_{1,i}) = \sum_{i=1}^n I((X_{1,i}, X_{2,i}) : Y_i).
 \end{aligned}$$

□

We next prove a technical lemma that was used in the previous proof.

**Lemma 4.30.** *For any distribution  $P_{X_1^n X_2^n}$  of  $(X_1^n, X_2^n)$ , if  $Y^n \in \mathcal{Y}^n$  is the outcome of  $W^n$  on inputs  $X_1^n, X_2^n$ , we have  $I(X_{1,-i} : Y_i | X_{1,i} X_2^n Y^{i-1}) = 0$ .*

*Proof.* Let us show that, conditioned on any particular instance of  $X_{1,i} = x_{i,1}$ ,  $X_2^n = x_2^n$ ,  $Y_1^{i-1} = y^{i-1}$ ,  $X_{1,-i}$  and  $Y_i$  are independent.

We have:

$$\begin{aligned} \mathbb{P}\left(Y_i = y_i | X_{1,i} = x_{i,1}, X_2^n = x_2^n, Y_1^{i-1} = y^{i-1}\right) &= \mathbb{P}\left(Y_i = y_i | X_{1,i} = x_{i,1}, X_{2,i} = x_{2,i}\right) \\ &= W(y_i | x_{1,i} x_{2,i}), \end{aligned} \quad (4.69)$$

by definition of the law of  $Y_i$ . On the other hand, we have that:

$$\mathbb{P}\left(X_1^n = x_1^n, X_2^n = x_2^n, Y^n = y_n\right) = \mathbb{P}\left(X_1^n = x_1^n, X_2^n = x_2^n\right) \prod_{j=1}^n W(y_j | x_{1,j} x_{2,j}).$$

Thus, we have that  $\mathbb{P}\left(X_{1,i} = x_{i,1}, X_2^n = x_2^n, Y_1^{i-1} = y^{i-1}\right)$  is equal to:

$$\begin{aligned} &\sum_{x_{1,-i}, x_2^n, y_i, \dots, y_n} \mathbb{P}\left(X_1^n = x_1^n, X_2^n = x_2^n\right) \prod_{j=1}^n W(y_j | x_{1,j} x_{2,j}) \\ &= \sum_{x_{1,-i}, x_2^n} \mathbb{P}\left(X_1^n = x_1^n, X_2^n = x_2^n\right) \prod_{j=1}^{i-1} W(y_j | x_{1,j} x_{2,j}) \prod_{j=i}^n \left(\sum_{y_j} W(y_j | x_{1,j} x_{2,j})\right) \\ &= \sum_{x_{1,-i}, x_2^n} \mathbb{P}\left(X_1^n = x_1^n, X_2^n = x_2^n\right) \prod_{j=1}^{i-1} W(y_j | x_{1,j} x_{2,j}). \end{aligned} \quad (4.70)$$

And then,  $\mathbb{P}\left(X_{1,-i} = x_{1,-i} | X_{1,i} = x_{i,1}, X_2^n = x_2^n, Y_1^{i-1} = y^{i-1}\right)$  is equal to:

$$\frac{\sum_{x_2^n} \mathbb{P}\left(X_1^n = x_1^n, X_2^n = x_2^n\right) \prod_{j=1}^{i-1} W(y_j | x_{1,j} x_{2,j})}{\sum_{x_{1,-i}, x_2^n} \mathbb{P}\left(X_1^n = x_1^n, X_2^n = x_2^n\right) \prod_{j=1}^{i-1} W(y_j | x_{1,j} x_{2,j})}.$$

But:

$$\begin{aligned} &\mathbb{P}\left(X_{1,-i} = x_{1,-i}, Y_i = y_i | X_{1,i} = x_{i,1}, X_2^n = x_2^n, Y_1^{i-1} = y^{i-1}\right) \\ &= \frac{\sum_{x_2^n} \mathbb{P}\left(X_1^n = x_1^n, X_2^n = x_2^n\right) \prod_{j=1}^i W(y_j | x_{1,j} x_{2,j})}{\sum_{x_{1,-i}, x_2^n} \mathbb{P}\left(X_1^n = x_1^n, X_2^n = x_2^n\right) \prod_{j=1}^{i-1} W(y_j | x_{1,j} x_{2,j})} \\ &= \mathbb{P}\left(X_{1,-i} = x_{1,-i} | X_{1,i} = x_{i,1}, X_2^n = x_2^n, Y_1^{i-1} = y^{i-1}\right) W(y_i | x_{1,i} x_{2,i}) \\ &= \mathbb{P}\left(X_{1,-i} = x_{1,-i} | X_{1,i} = x_{i,1}, X_2^n = x_2^n, Y_1^{i-1} = y^{i-1}\right) \\ &\times \mathbb{P}\left(Y_i = y_i | X_{1,i} = x_{i,1}, X_2^n = x_2^n, Y_1^{i-1} = y^{i-1}\right). \end{aligned} \quad (4.71)$$

Thus, conditioned on any particular instance of  $X_{1,i} = x_{i,1}$ ,  $X_2^n = x_2^n$ ,  $Y_1^{i-1} = y^{i-1}$ ,  $X_{1,-i}$  and  $Y_i$  are independent, and so  $I(X_{1,-i} : Y_i | X_{1,i} X_2^n Y_1^{i-1}) = 0$ .  $\square$

Combining the previous results gives the desired outer bound.

**Proposition 4.31** (Outer bound part of Theorem 4.25). *If a rate pair is achievable with relaxed non-signaling assistance then it is in the closure of the convex hull of all  $(R_1, R_2)$  satisfying:*

$$R_1 < I(X_1 : Y|X_2), \quad R_2 < I(X_2 : Y|X_1), \quad R_1 + R_2 < I((X_1, X_2) : Y),$$

for  $(X_1, X_2)$  following some law  $P_{X_1 X_2}$  on  $\mathcal{X}_1 \times \mathcal{X}_2$ , and  $Y \in \mathcal{Y}$  the outcome of  $W$  on inputs  $X_1, X_2$ .

*Proof.* Consider  $(R_1, R_2)$  achievable with relaxed non-signaling assistance: we have a sequence of relaxed non-signaling assisted codes for  $n$  copies of the MAC  $W$  with  $k_1 = 2^{nR_1}, k_2 = 2^{nR_2}$  messages and an error probability  $\varepsilon_n \xrightarrow{n \rightarrow +\infty} 0$ , along with associated distributions of  $X_1^n X_2^n Y^n$ .

Thus combining Lemma 4.28 and Lemma 4.29, we have that:

$$\begin{aligned} R_1 &\leq \frac{1}{n} \frac{I(X_1^n : Y^n | X_2^n) + h(\varepsilon_n)}{1 - \varepsilon_n} \leq \frac{1}{n} \frac{\sum_{i=1}^n I(X_{1,i} : Y_i | X_{2,i}) + h(\varepsilon_n)}{1 - \varepsilon_n}, \\ R_2 &\leq \frac{1}{n} \frac{I(X_2^n : Y^n | X_1^n) + h(\varepsilon_n)}{1 - \varepsilon_n} \leq \frac{1}{n} \frac{\sum_{i=1}^n I(X_{2,i} : Y_i | X_{1,i}) + h(\varepsilon_n)}{1 - \varepsilon_n}, \\ R_1 + R_2 &\leq \frac{1}{n} \frac{I((X_1^n, X_2^n) : Y^n) + h(\varepsilon_n)}{1 - \varepsilon_n} \leq \frac{1}{n} \frac{\sum_{i=1}^n I((X_{1,i}, X_{2,i}) : Y_i) + h(\varepsilon_n)}{1 - \varepsilon_n}. \end{aligned} \quad (4.72)$$

Then let us consider some random variable  $Q$  uniform on  $[n]$  and independent of  $(X_1^n, X_2^n, Y^n)$ . Then we can write:

$$\sum_{i=1}^n I(X_{1,i} : Y_i | X_{2,i}) = \sum_{i=1}^n I(X_{1,i} : Y_i | X_{2,i}, Q = i) = nI(X_{1,Q} : Y_Q | X_{2,Q}, Q).$$

Since  $Y_Q$  conditioned on  $X_{1,Q}$  and  $X_{2,Q}$  still follows the law of the MAC  $W(y|x_1 x_2)$ , we can take  $X_1 = X_{1,Q}, X_2 = X_{2,Q}$ , and then the output of the channel  $Y$  satisfies  $Y = Y_Q$ , and thus we obtain:

$$R_1 \leq \frac{I(X_1 : Y | X_2, Q) + \frac{h(\varepsilon_n)}{n}}{1 - \varepsilon_n}.$$

Doing this similarly on the other conditional mutual informations, we get:

$$\begin{aligned} R_1 &\leq \frac{I(X_1 : Y | X_2, Q) + \frac{h(\varepsilon_n)}{n}}{1 - \varepsilon_n}, \\ R_2 &\leq \frac{I(X_2 : Y | X_1, Q) + \frac{h(\varepsilon_n)}{n}}{1 - \varepsilon_n}, \\ R_1 + R_2 &\leq \frac{I((X_1, X_2) : Y | Q) + \frac{h(\varepsilon_n)}{n}}{1 - \varepsilon_n}. \end{aligned} \quad (4.73)$$

By taking the limit as  $n$  goes to infinity, since the limit of  $\varepsilon_n$  is 0, then the limit of  $\frac{h(\varepsilon_n)}{n}$  is 0 as well and we get that  $(R_1, R_2)$  must be in the set of rate pairs such that:

$$\begin{aligned} R_1 &\leq I(X_1 : Y | X_2, Q), \\ R_2 &\leq I(X_2 : Y | X_1, Q), \\ R_1 + R_2 &\leq I((X_1, X_2) : Y | Q), \end{aligned} \quad (4.74)$$

for some uniform  $Q$  in a finite set,  $(X_1, X_2)$  any joint law depending on  $Q$ , and  $Y$  the output of  $W$  on inputs  $(X_1, X_2)$ .

Finally, in order to show that this is the right region, one has only to see that the corner points of this region, such as for instance  $(I(X_1 : Y|Q), I(X_2 : Y|X_1, Q))$ , are finite convex combination of the points  $(I(X_1 : Y|Q = q), I(X_2 : Y|X_1, Q = q))$  which are all in the capacity region of the theorem by taking  $(X_1 X_2) \sim P_{X_1 X_2|Q=q}$ . This implies that  $(R_1, R_2)$  is in the convex hull of that region, so we can drop the random variable  $Q$  and the proof is completed.  $\square$

The main consequence of that outer bound on the relaxed non-signaling assisted capacity region is that it holds also for the non-signaling assisted capacity region thanks to Corollary 4.24:

**Corollary 4.32** (Outer Bound on the Non-Signaling Assisted Capacity Region). *If a rate pair is achievable with non-signaling assistance, then it is in the closure of the convex hull of all  $(R_1, R_2)$  satisfying:*

$$R_1 < I(X_1 : Y|X_2), \quad R_2 < I(X_2 : Y|X_1), \quad R_1 + R_2 < I((X_1, X_2) : Y),$$

for  $(X_1, X_2)$  following any law  $P_{X_1 X_2}$  on  $\mathcal{X}_1 \times \mathcal{X}_2$ , and  $Y \in \mathcal{Y}$  the outcome of  $W$  on inputs  $X_1, X_2$ .

#### 4.5.2 Achievability Part of Theorem 4.25

In order to construct the relaxed non-signaling assisted code for achievability, we will use the notions of jointly and conditional typical sets described in Section 2.2.2:

**Proposition 4.33** (Achievability part of Theorem 4.25). *If a rate pair is in the closure of the convex hull of  $(R_1, R_2)$  satisfying:*

$$R_1 < I(X_1 : Y|X_2), \quad R_2 < I(X_2 : Y|X_1), \quad R_1 + R_2 < I((X_1, X_2) : Y),$$

for  $(X_1, X_2)$  following some law  $P_{X_1 X_2}$  on  $\mathcal{X}_1 \times \mathcal{X}_2$ , and  $Y \in \mathcal{Y}$  the outcome of  $W$  on inputs  $X_1, X_2$ , then it is in  $\mathcal{C}^{\text{NS}}(W)$ .

*Proof.* Let us fix  $\varepsilon, \varepsilon' \in (0, 1)$  such that  $\varepsilon' < \varepsilon \leq \frac{1}{2}$ . Let  $n \in \mathbb{N}$  which will be chosen large enough during the proof.

We consider  $n$  independent random variables  $(X_{1,i} X_{2,i} Y_i) \sim P_{X_1 X_2 Y}$ , following the distribution  $P_{X_1 X_2 Y}(x_{1,i}, x_{2,i}, y_i) = W(y_i|x_{1,i} x_{2,i}) P_{X_1 X_2}(x_{1,i}, x_{2,i})$ . We call  $P_{X_1^n X_2^n Y^n}$  the law of their product. We have then  $P_{X_1^n X_2^n}(x_1^n, x_2^n) := \prod_{i=1}^n P_{X_1 X_2}(x_{1,i}, x_{2,i})$ . If  $\hat{Y}$  is the output of  $W^{\otimes n}$  on  $X_1^n X_2^n$ , we have that:

$$\begin{aligned} P_{X_1^n X_2^n \hat{Y}}(x_1^n, x_2^n, y^n) &= W^{\otimes n}(y^n|x_1^n x_2^n) P_{X_1^n X_2^n}(x_1^n, x_2^n) \\ &= W^{\otimes n}(y^n|x_1^n x_2^n) \prod_{i=1}^n P_{X_1 X_2}(x_{1,i}, x_{2,i}) \\ &= \prod_{i=1}^n W(y_i|x_{1,i} x_{2,i}) P_{X_1 X_2}(x_{1,i}, x_{2,i}) \\ &= \prod_{i=1}^n P_{X_1 X_2 Y}(x_{1,i}, x_{2,i}, y_i). \end{aligned} \tag{4.75}$$

Thus,  $\hat{Y}$  follows the product law of  $Y_i$ , i.e.  $\hat{Y} = Y^n$ .

Let us consider  $C_1, C_2, C_3$  some positive numbers independent of  $n$  and  $\varepsilon$  which we will define later,  $k_1 = 2^{nR_1}, k_2 = 2^{nR_2}$  integers with  $(R_1, R_2)$  positive rates such that:

$$\begin{aligned} R_1 &\leq I(X_1 : Y|X_2) - \frac{1}{n} - C_1\varepsilon, \\ R_2 &\leq I(X_2 : Y|X_1) - \frac{1}{n} - C_2\varepsilon, \\ R_1 + R_2 &\leq I((X_1, X_2) : Y) - \frac{1}{n} - C_3\varepsilon. \end{aligned} \quad (4.76)$$

We define a solution of  $S^{\overline{\text{NS}}}(W^{\otimes n}, 2^{nR_1}, 2^{nR_2})$  in the following way:

$$p_{x_1^n, x_2^n} := \begin{cases} \frac{2^{n(R_1+R_2)} P_{X_1^n X_2^n}(x_1^n, x_2^n)}{\sum_{(x_1^n, x_2^n) \in \mathcal{T}_\varepsilon^n(X_1, X_2)} P_{X_1^n X_2^n}(x_1^n, x_2^n)} & \text{if } (x_1^n, x_2^n) \in \mathcal{T}_\varepsilon^n(X_1, X_2), \\ 0 & \text{otherwise.} \end{cases}$$

and:

$$r_{x_1^n, x_2^n, y^n} := \begin{cases} p_{x_1^n, x_2^n} & \text{if } (x_1^n, x_2^n, y^n) \in \mathcal{T}_{\varepsilon'}^n(X_1, X_2, Y), \\ 0 & \text{otherwise.} \end{cases}$$

By construction, the constraint  $0 \leq r_{x_1^n, x_2^n, y^n} \leq p_{x_1^n, x_2^n}$  is satisfied. We have also that:

$$\sum_{x_1^n, x_2^n} p_{x_1^n, x_2^n} = \sum_{(x_1^n, x_2^n) \in \mathcal{T}_\varepsilon^n(X_1, X_2)} \frac{2^{n(R_1+R_2)} P_{X_1^n X_2^n}(x_1^n, x_2^n)}{\sum_{(x_1^n, x_2^n) \in \mathcal{T}_\varepsilon^n(X_1, X_2)} P_{X_1^n X_2^n}(x_1^n, x_2^n)} = 2^{n(R_1+R_2)},$$

which is equal to  $k_1 k_2$ . If  $(x_1^n, x_2^n, y^n) \in \mathcal{T}_{\varepsilon'}^n(X_1, X_2, Y)$ , we have that  $(x_1^n, x_2^n) \in \mathcal{T}_{\varepsilon'}^n(X_1, X_2) \subseteq \mathcal{T}_\varepsilon^n(X_1, X_2)$ , so in that case:

$$r_{x_1^n, x_2^n, y^n} = \frac{2^{n(R_1+R_2)} P_{X_1^n X_2^n}(x_1^n, x_2^n)}{\sum_{(x_1^n, x_2^n) \in \mathcal{T}_\varepsilon^n(X_1, X_2)} P_{X_1^n X_2^n}(x_1^n, x_2^n)}.$$

If  $y^n \notin \mathcal{T}_{\varepsilon'}^n(Y)$ , then for all  $(x_1^n, x_2^n), (x_1^n, x_2^n, y^n) \notin \mathcal{T}_{\varepsilon'}^n(X_1, X_2, Y)$ , so  $\sum_{x_1^n, x_2^n} r_{x_1^n, x_2^n, y^n} = 0 \leq 1$  in that case.

Otherwise, if  $y^n \in \mathcal{T}_{\varepsilon'}^n(Y)$ , then:

$$\begin{aligned} \sum_{x_1^n, x_2^n} r_{x_1^n, x_2^n, y^n} &= 2^{n(R_1+R_2)} \frac{\sum_{(x_1^n, x_2^n) \in \mathcal{T}_{\varepsilon'}^n(X_1, X_2|y^n)} P_{X_1^n X_2^n}(x_1^n, x_2^n)}{\sum_{(x_1^n, x_2^n) \in \mathcal{T}_\varepsilon^n(X_1, X_2)} P_{X_1^n X_2^n}(x_1^n, x_2^n)} \\ &\leq 2^{n(R_1+R_2)} \frac{\sum_{(x_1^n, x_2^n) \in \mathcal{T}_\varepsilon^n(X_1, X_2|y^n)} P_{X_1^n X_2^n}(x_1^n, x_2^n)}{\sum_{(x_1^n, x_2^n) \in \mathcal{T}_\varepsilon^n(X_1, X_2)} P_{X_1^n X_2^n}(x_1^n, x_2^n)} \\ &\leq 2^{n(R_1+R_2)} \frac{2^{-n(1-\varepsilon)H(X_1, X_2)} |\mathcal{T}_\varepsilon^n(X_1, X_2|y^n)|}{2^{-n(1+\varepsilon)H(X_1, X_2)} |\mathcal{T}_\varepsilon^n(X_1, X_2)|} \text{ since } (x_1^n, x_2^n) \in \mathcal{T}_\varepsilon^n(X_1, X_2) \\ &= 2^{n(R_1+R_2+2\varepsilon H(X_1, X_2))} \frac{|\mathcal{T}_\varepsilon^n(X_1, X_2|y^n)|}{|\mathcal{T}_\varepsilon^n(X_1, X_2)|}. \end{aligned} \quad (4.77)$$

But  $|\mathcal{T}_\varepsilon^n(X_1, X_2|y^n)| \leq 2^{n(1+\varepsilon)H(X_1, X_2|Y)}$  and for a large enough  $n$ ,  $|\mathcal{T}_\varepsilon^n(X_1, X_2)| \geq (1 - \varepsilon)2^{n(1-\varepsilon)H(X_1, X_2)} \geq 2^{n((1-\varepsilon)H(X_1, X_2) - \frac{1}{n})}$ , so in that case:

$$\begin{aligned} \sum_{x_1^n, x_2^n} r_{x_1^n, x_2^n, y^n} &\leq 2^{n(R_1 + R_2 + 2\varepsilon H(X_1, X_2))} \frac{2^{n(1+\varepsilon)H(X_1, X_2|Y)}}{2^{n((1-\varepsilon)H(X_1, X_2) - \frac{1}{n})}} \\ &= 2^{n(R_1 + R_2 - I(X_1, X_2:Y) + \frac{1}{n} + C_3\varepsilon)} \leq 1, \end{aligned} \quad (4.78)$$

since  $I(X_1, X_2 : Y) = H(X_1, X_2) - H(X_1, X_2|Y)$  and  $R_1 + R_2 \leq I(X_1, X_2 : Y) - \frac{1}{n} - C_3\varepsilon$ , with  $C_3 := H(X_1, X_2|Y) + 3H(X_1, X_2)$ .

Let us focus on the constraint  $\sum_{x_1^n} p_{x_1^n, x_2^n} \geq k_1 \sum_{x_1^n} r_{x_1^n, x_2^n, y^n}$  (the symmetric constraint  $\sum_{x_2^n} p_{x_1^n, x_2^n} \geq k_2 \sum_{x_2^n} r_{x_1^n, x_2^n, y^n}$  will be achieved for symmetric reasons).

Let us fix  $(x_2^n, y^n)$ . If  $(x_2^n, y^n) \notin \mathcal{T}_{\varepsilon'}^n(X_2, Y)$ , then for all  $x_1^n$ ,  $(x_1^n, x_2^n, y^n) \notin \mathcal{T}_{\varepsilon'}^n(X_1, X_2, Y)$ , thus  $r_{x_1^n, x_2^n, y^n} = 0$  and the constraint is fulfilled. Let us assume that  $(x_2^n, y^n) \in \mathcal{T}_{\varepsilon'}^n(X_2, Y)$ . Since  $r_{x_1^n, x_2^n, y^n} > 0$  implies that  $(x_1^n, x_2^n, y^n) \in \mathcal{T}_{\varepsilon'}^n(X_1, X_2, Y)$ , we have that:

$$\sum_{x_1^n} r_{x_1^n, x_2^n, y^n} = \sum_{x_1^n \in \mathcal{T}_{\varepsilon'}^n(X_1|x_2^n, y^n)} r_{x_1^n, x_2^n, y^n} = \sum_{x_1^n \in \mathcal{T}_{\varepsilon'}^n(X_1|x_2^n, y^n)} p_{x_1^n, x_2^n}.$$

Thus:

$$\begin{aligned} \frac{\sum_{x_1^n} p_{x_1^n, x_2^n}}{k_1 \sum_{x_1^n} r_{x_1^n, x_2^n, y^n}} &\geq \frac{1}{k_1} \frac{\sum_{x_1 \in \mathcal{T}_\varepsilon^n(X_1|x_2^n)} P_{X_1^n X_2^n}(x_1^n, x_2^n)}{\sum_{x_1 \in \mathcal{T}_{\varepsilon'}^n(X_1|x_2^n, y^n)} P_{X_1^n X_2^n}(x_1^n, x_2^n)} \\ &\geq \frac{1}{k_1} \frac{\sum_{x_1 \in \mathcal{T}_\varepsilon^n(X_1|x_2^n)} P_{X_1^n X_2^n}(x_1^n, x_2^n)}{\sum_{x_1 \in \mathcal{T}_\varepsilon^n(X_1|x_2^n, y^n)} P_{X_1^n X_2^n}(x_1^n, x_2^n)} \\ &\geq \frac{1}{k_1} \frac{2^{-n(1+\varepsilon)H(X_1, X_2)} |\mathcal{T}_\varepsilon^n(X_1|x_2^n)|}{2^{-n(1-\varepsilon)H(X_1, X_2)} |\mathcal{T}_\varepsilon^n(X_1|x_2^n, y^n)|} \\ &\geq 2^{n(-R_1 - 2\varepsilon H(X_1, X_2))} \frac{|\mathcal{T}_\varepsilon^n(X_1|x_2^n)|}{|\mathcal{T}_\varepsilon^n(X_1|x_2^n, y^n)|}. \end{aligned} \quad (4.79)$$

But  $|\mathcal{T}_\varepsilon^n(X_1|x_2^n, y^n)| \leq 2^{n(1+\varepsilon)H(X_1|X_2Y)}$  and for a large enough  $n$  we have  $\forall x_2^n \in \mathcal{T}_{\varepsilon'}^n(X_2)$ ,  $|\mathcal{T}_\varepsilon^n(X_1|x_2^n)| \geq (1 - \varepsilon)2^{n(1-\varepsilon)H(X_1|X_2)} \geq 2^{n((1-\varepsilon)H(X_1|X_2) - \frac{1}{n})}$ , so we get with  $C_1 := 2H(X_1, X_2) + H(X_1|X_2Y) + H(X_1|X_2)$  (symmetrically  $C_2 := 2H(X_1, X_2) + H(X_2|X_1Y) + H(X_2|X_1)$ ):

$$\begin{aligned} \frac{\sum_{x_1^n} p_{x_1^n, x_2^n}}{k_1 \sum_{x_1^n} r_{x_1^n, x_2^n, y^n}} &\geq 2^{n(H(X_1|X_2) - \frac{1}{n} - H(X_1|X_2Y) - R_1 - C_1\varepsilon)} \\ &= 2^{n(I(X_1:Y|X_2) - \frac{1}{n} - C_1\varepsilon - R_1)} \geq 1. \end{aligned} \quad (4.80)$$

For a large enough  $n$ , all constraints are satisfied, thus  $(p_{x_1^n, x_2^n}, r_{x_1^n, x_2^n, y^n})$  is a valid solution.

Then:

$$\begin{aligned}
 \mathcal{S}^{\overline{\text{NS}}}(W^{\otimes n}, 2^{nR_1}, 2^{nR_2}) &\geq \frac{1}{2^{n(R_1+R_2)}} \sum_{(x_1^n, x_2^n, y^n) \in \mathcal{T}_{\varepsilon'}^n(X_1, X_2, Y)} W^{\otimes n}(y^n | x_1^n x_2^n) r_{x_1^n, x_2^n, y^n} \\
 &= \sum_{(x_1^n, x_2^n, y^n) \in \mathcal{T}_{\varepsilon'}^n(X_1, X_2, Y)} \frac{P_{X_1^n X_2^n Y^n}(x_1^n, x_2^n, y^n)}{P_{X_1^n X_2^n}(x_1^n, x_2^n)} \frac{P_{X_1^n X_2^n}(x_1^n, x_2^n)}{\sum_{(x_1^n, x_2^n) \in \mathcal{T}_{\varepsilon}^n(X_1, X_2)} P_{X_1^n X_2^n}(x_1^n, x_2^n)} \\
 &= \frac{\sum_{(x_1^n, x_2^n, y^n) \in \mathcal{T}_{\varepsilon'}^n(X_1, X_2, Y)} P_{X_1^n X_2^n Y^n}(x_1^n, x_2^n, y^n)}{\sum_{(x_1^n, x_2^n) \in \mathcal{T}_{\varepsilon}^n(X_1, X_2)} P_{X_1^n X_2^n}(x_1^n, x_2^n)} \xrightarrow{n \rightarrow +\infty} 1,
 \end{aligned} \tag{4.81}$$

since typical sets cover asymptotically the whole probability mass. Thus, we get that  $\mathcal{S}^{\overline{\text{NS}}}(W^{\otimes n}, 2^{nR_1}, 2^{nR_2}) \xrightarrow{n \rightarrow +\infty} 1$  since  $\mathcal{S}^{\overline{\text{NS}}}(W^{\otimes n}, 2^{nR_1}, 2^{nR_2}) \leq 1$ . Therefore, for sufficiently large  $n$  we can achieve a rate pair arbitrarily close to the outer bound. Finally, since  $\mathcal{C}^{\overline{\text{NS}}}(W)$  is closed and convex, a rate pair that is in the closure of the convex hull of the initial region is also in  $\mathcal{C}^{\overline{\text{NS}}}(W)$ , and thus the proof is completed.  $\square$

## 4.6 Independent Non-Signaling Assisted Capacity Region

The goal of this section is to show that independent non-signaling assistance does not change the capacity region of a MAC  $W$ , i.e. that  $\mathcal{C}^{\text{NS}_{\text{SR}}}(W) = \mathcal{C}(W)$ . In order to prove this result, we will need some properties in the one-sender one-receiver case from [BF18] recalled in Section 2.3.

Let us state our result on independent non-signaling assistance, which says that even in one-shot scenarios, the success probability with and without that assistance are close:

**Theorem 4.34.** *For any  $\ell_1, k_1, \ell_2, k_2$ ,  $S_{\text{sum}}(W, \ell_1, \ell_2)$  is larger than or equal to:*

$$\min \left( \frac{k_1}{\ell_1} \left( 1 - \left( 1 - \frac{1}{k_1} \right)^{\ell_1} \right), \frac{k_2}{\ell_2} \left( 1 - \left( 1 - \frac{1}{k_2} \right)^{\ell_2} \right) \right) S_{\text{sum}}^{\text{NS}_{\text{SR}}}(W, k_1, k_2).$$

In particular, this will imply that the capacity regions are the same:

**Corollary 4.35.**  $\mathcal{C}^{\text{NS}_{\text{SR}}}(W) = \mathcal{C}(W)$ .

*Proof.* We will show that  $\mathcal{C}_{\text{sum}}^{\text{NS}_{\text{SR}}}(W) = \mathcal{C}_{\text{sum}}(W)$ , which is enough to conclude thanks to Proposition 4.2 and Proposition 4.3. We apply Theorem 4.34 on the MAC  $W^{\otimes n}$ .

Let us fix  $k_1 = 2^{nR_1}$ ,  $k_2 = 2^{nR_2}$  and  $\ell_1 = \frac{2^{nR_1}}{n}$ ,  $\ell_2 = \frac{2^{nR_2}}{n}$ . Since:

$$\frac{k}{\ell} \left( 1 - \left( 1 - \frac{1}{k} \right)^{\ell} \right) \geq \frac{k}{\ell} \left( 1 - e^{-\frac{\ell}{k}} \right) \geq 1 - \frac{\ell}{2k},$$

and  $1 - \frac{\ell_1}{2k_1} = 1 - \frac{\ell_2}{2k_2} = 1 - \frac{1}{2n}$ , we get:

$$\left( 1 - \frac{1}{2n} \right) S_{\text{sum}}^{\text{NS}_{\text{SR}}}(W^{\otimes n}, 2^{nR_1}, 2^{nR_2}) \leq S_{\text{sum}} \left( W^{\otimes n}, \frac{2^{nR_1}}{n}, \frac{2^{nR_2}}{n} \right).$$

As  $1 - \frac{1}{2^n}$  tends to 1 when  $n$  tends to infinity, we get that  $\forall \varepsilon > 0, \exists N \in \mathbb{N}, \forall n \geq N$ :

$$(1 - \varepsilon) S_{\text{sum}}^{\text{NSSR}}(W^{\otimes n}, 2^{nR_1}, 2^{nR_1}) \leq S_{\text{sum}}(W^{\otimes n}, 2^{n(R_1 - \frac{\log(n)}{n})}, 2^{n(R_2 - \frac{\log(n)}{n})}).$$

Thus, if  $\lim_{n \rightarrow +\infty} S_{\text{sum}}^{\text{NSSR}}(W^{\otimes n}, 2^{nR_1}, 2^{nR_1}) = 1$ , we have that for all  $R'_1 < R_1$  and  $R'_2 < R_2$ :

$$\lim_{n \rightarrow +\infty} S_{\text{sum}}(W^{\otimes n}, 2^{nR'_1}, 2^{nR'_1}) \geq 1 - \varepsilon.$$

Since this is true for all  $\varepsilon > 0$ , we get in fact that  $\lim_{n \rightarrow +\infty} S_{\text{sum}}(W^{\otimes n}, 2^{nR'_1}, 2^{nR'_1}) = 1$ . This implies that  $\mathcal{C}_{\text{sum}}^{\text{NSSR}}(W) \subseteq \mathcal{C}_{\text{sum}}(W)$ , and thus that the capacity regions are equal as the other inclusion is always satisfied.  $\square$

In order to prove Theorem 4.34, we will need the following lemma:

**Lemma 4.36.** *If  $S_1, S_2$  are classical codes (i.e. multisets with elements in  $\mathcal{X}_1, \mathcal{X}_2$ ) of size  $\ell_1, \ell_2$ :*

$$S_{\text{sum}}(W, \ell_1, \ell_2) \geq \frac{1}{2} \left( \frac{f_{W_{S_2, \ell_2}^1}(S_1)}{\ell_1} + \frac{f_{W_{S_1, \ell_1}^2}(S_2)}{\ell_2} \right),$$

where  $W_{S_2, \ell_2}^1$  is the channel defined by  $W_{S_2, \ell_2}^1(y|x_1) = \frac{1}{\ell_2} \sum_{i_2=1}^{\ell_2} W(y|x_1 S_2^{i_2})$  and similarly for  $W_{S_1, \ell_1}^2$ .

*Proof.* Let us define  $e_1(x_1|i_1) := \mathbb{1}_{S_1^{i_1}=x_1}$  and  $e_2(x_2|i_2) := \mathbb{1}_{S_2^{i_2}=x_2}$ . Then for fixed  $y$ , let us take  $j_1^y \in \operatorname{argmax}_{i_1} \{\sum_{i_2=1}^{\ell_2} W(y|S_1^{i_1} S_2^{i_2})\}$ ,  $j_2^y \in \operatorname{argmax}_{i_2} \{\sum_{i_1=1}^{\ell_1} W(y|S_1^{i_1} S_2^{i_2})\}$  and then define  $d(j_1|y) := \mathbb{1}_{j_1=j_1^y}$ ,  $d(j_2|y) := \mathbb{1}_{j_2=j_2^y}$ . We have then:

$$\begin{aligned} S_{\text{sum}}(W, \ell_1, \ell_2) &\geq \frac{1}{\ell_1 \ell_2} \sum_{i_1, i_2, x_1, x_2, y} W(y|x_1 x_2) \mathbb{1}_{S_1^{i_1}=x_1} \mathbb{1}_{S_2^{i_2}=x_2} \frac{\mathbb{1}_{i_1=i_1^y} + \mathbb{1}_{i_2=i_2^y}}{2} \\ &= \frac{1}{\ell_1 \ell_2} \sum_{i_1, i_2, y} W(y|S_1^{i_1} S_2^{i_2}) \frac{\mathbb{1}_{i_1=i_1^y} + \mathbb{1}_{i_2=i_2^y}}{2} \\ &= \frac{1}{\ell_1 \ell_2} \sum_y \frac{1}{2} \left( \sum_{i_2} W(y|S_1^{j_1^y} S_2^{i_2}) + \sum_{i_1} W(y|S_1^{i_1} S_2^{j_2^y}) \right) \\ &= \frac{1}{\ell_1 \ell_2} \sum_y \frac{1}{2} \left( \max_{i_1} \sum_{i_2} W(y|S_1^{i_1} S_2^{i_2}) + \max_{i_2} \sum_{i_1} W(y|S_1^{i_1} S_2^{i_2}) \right) \tag{4.82} \\ &= \frac{1}{2} \left( \frac{\sum_y \max_{i_1} \left[ \frac{1}{\ell_2} \sum_{i_2} W(y|S_1^{i_1} S_2^{i_2}) \right]}{\ell_1} + \frac{\sum_y \max_{i_2} \left[ \frac{1}{\ell_1} \sum_{i_1} W(y|S_1^{i_1} S_2^{i_2}) \right]}{\ell_2} \right) \\ &= \frac{1}{2} \left( \frac{\sum_y \max_{i_1} W_{S_2, \ell_2}^1(y|S_1^{i_1})}{\ell_1} + \frac{\sum_y \max_{i_2} W_{S_1, \ell_1}^2(y|S_2^{i_2})}{\ell_2} \right) \\ &= \frac{1}{2} \left( \frac{f_{W_{S_2, \ell_2}^1}(S_1)}{\ell_1} + \frac{f_{W_{S_1, \ell_1}^2}(S_2)}{\ell_2} \right). \end{aligned}$$

$\square$



We have now all the tools to prove Theorem 4.34:

*Proof of Theorem 4.34.* Let us consider an optimal solution  $r^1, r^2, p^1, p^2$  of the program of Proposition 4.8 computing  $S_{\text{sum}}^{\text{NSR}}(W, k_1, k_2)$ .

Let us fix some multiset  $S_2$  with elements in  $\mathcal{X}_2$  of size  $\ell_2$ . Note that  $r^1$  and  $p^1$  are a feasible solution of the program of Proposition 2.17 computing  $S^{\text{NS}}(W_{S_2, \ell_2}^1, k_1)$ . As a result, we can apply Theorem 2.18 and get the following statement. For the multiset  $S_1$  obtained by choosing  $\ell_1$  elements of  $\mathcal{X}_1$  independently according to the distribution  $\left(\frac{p_{x_1}^1}{k_1}\right)_{x_1 \in \mathcal{X}_1}$ , we have:

$$\mathbb{E}_{S_1} \left[ \frac{f_{W_{S_2, \ell_2}^1}(S_1)}{\ell_1} \right] \geq \frac{k_1}{\ell_1} \left( 1 - \left( 1 - \frac{1}{k_1} \right)^{\ell_1} \right) \cdot \frac{1}{k_1} \sum_{x_1, y} W_{S_2, \ell_2}^1(y|x_1) r_{x_1, y}^1.$$

Now, let  $S_2$  be the multiset obtained by choosing  $\ell_2$  elements of  $\mathcal{X}_2$  independently according to the distribution  $\left(\frac{p_{x_2}^2}{k_2}\right)_{x_2 \in \mathcal{X}_2}$ . We have:

$$\begin{aligned} \mathbb{E}_{S_2} \left[ \frac{1}{k_1} \sum_{x_1, y} W_{S_2, \ell_2}^1(y|x_1) r_{x_1, y}^1 \right] &= \mathbb{E}_{S_2} \left[ \frac{1}{k_1} \sum_{x_1, y} \frac{1}{\ell_2} \sum_{i_2=1}^{\ell_2} W(y|x_1 S_2^{i_2}) r_{x_1, y}^1 \right] \\ &= \frac{1}{\ell_2} \sum_{i_2=1}^{\ell_2} \mathbb{E}_{X_2^{i_2} \sim \frac{p_{x_2}^2}{k_2}} \left[ \frac{1}{k_1} \sum_{x_1, y} W(y|x_1 X_2^{i_2}) r_{x_1, y}^1 \right] = \mathbb{E}_{X_2 \sim \frac{p_{x_2}^2}{k_2}} \left[ \frac{1}{k_1} \sum_{x_1, y} W(y|x_1 X_2) r_{x_1, y}^1 \right] \\ &= \frac{1}{k_1} \sum_{x_1, x_2, y} \frac{p_{x_2}^2}{k_2} W(y|x_1 x_2) r_{x_1, y}^1 = \frac{1}{k_1} \sum_{x_1, y} W_{p^2, k_2}^1(y|x_1) r_{x_1, y}^1. \end{aligned} \tag{4.83}$$

Thus in all, we have:

$$\begin{aligned} \mathbb{E}_{S_2} \left[ \mathbb{E}_{S_1} \left[ \frac{f_{W_{S_2, \ell_2}^1}(S_1)}{\ell_1} \right] \right] &\geq \mathbb{E}_{S_2} \left[ \frac{k_1}{\ell_1} \left( 1 - \left( 1 - \frac{1}{k_1} \right)^{\ell_1} \right) \cdot \frac{1}{k_1} \sum_{x_1, y} W_{S_2, \ell_2}^1(y|x_1) r_{x_1, y}^1 \right] \\ &= \frac{k_1}{\ell_1} \left( 1 - \left( 1 - \frac{1}{k_1} \right)^{\ell_1} \right) \cdot \mathbb{E}_{S_2} \left[ \frac{1}{k_1} \sum_{x_1, y} W_{S_2, \ell_2}^1(y|x_1) r_{x_1, y}^1 \right] \\ &\geq \frac{k_1}{\ell_1} \left( 1 - \left( 1 - \frac{1}{k_1} \right)^{\ell_1} \right) \cdot \frac{1}{k_1} \sum_{x_1, y} W_{p^2, k_2}^1(y|x_1) r_{x_1, y}^1, \end{aligned} \tag{4.84}$$

and symmetrically for  $\mathbb{E}_{S_1} \left[ \mathbb{E}_{S_2} \left[ \frac{f_{W_{S_1, \ell_1}^2}(S_2)}{\ell_2} \right] \right]$ . Since there exists codes  $S_1^*, S_2^*$  such that:

$$\frac{1}{2} \left( \frac{f_{W_{S_2^*, \ell_2}^1}(S_1^*)}{\ell_1} + \frac{f_{W_{S_1^*, \ell_1}^2}(S_2^*)}{\ell_2} \right) \geq \mathbb{E}_{S_1, S_2} \left[ \frac{1}{2} \left( \frac{f_{W_{S_2, \ell_2}^1}(S_1)}{\ell_1} + \frac{f_{W_{S_1, \ell_1}^2}(S_2)}{\ell_2} \right) \right],$$

and by applying Lemma 4.36, we get:

$$\begin{aligned}
 S_{\text{sum}}(W, \ell_1, \ell_2) &\geq \frac{1}{2} \left( \frac{f_{W_{S_2^*, \ell_2}^1}(S_1^*)}{\ell_1} + \frac{f_{W_{S_1^*, \ell_1}^2}(S_2^*)}{\ell_2} \right) \\
 &\geq \mathbb{E}_{S_1, S_2} \left[ \frac{1}{2} \left( \frac{f_{W_{S_2, \ell_2}^1}(S_1)}{\ell_1} + \frac{f_{W_{S_1, \ell_1}^2}(S_2)}{\ell_2} \right) \right] \\
 &= \frac{1}{2} \left( \mathbb{E}_{S_2} \left[ \mathbb{E}_{S_1} \left[ \frac{f_{W_{S_2, \ell_2}^1}(S_1)}{\ell_1} \right] \right] + \mathbb{E}_{S_1} \left[ \mathbb{E}_{S_2} \left[ \frac{f_{W_{S_1, \ell_1}^2}(S_2)}{\ell_2} \right] \right] \right) \\
 &\geq \frac{k_1}{2\ell_1} \left( 1 - \left( 1 - \frac{1}{k_1} \right)^{\ell_1} \right) \cdot \frac{1}{k_1} \sum_{x_1, y} W_{p^1}^1(y|x_1) r_{x_1, y}^1 \\
 &\quad + \frac{k_2}{2\ell_2} \left( 1 - \left( 1 - \frac{1}{k_2} \right)^{\ell_2} \right) \cdot \frac{1}{k_2} \sum_{x_2, y} W_{p^1}^2(y|x_2) r_{x_2, y}^2 \\
 &\geq \min \left( \frac{k_1}{\ell_1} \left( 1 - \left( 1 - \frac{1}{k_1} \right)^{\ell_1} \right), \frac{k_2}{\ell_2} \left( 1 - \left( 1 - \frac{1}{k_2} \right)^{\ell_2} \right) \right) S_{\text{sum}}^{\text{NSSR}}(W, k_1, k_2),
 \end{aligned} \tag{4.85}$$

which concludes the proof.  $\square$

*Remark.* In the whole proof of Theorem 4.34, as well as the properties it depends on, we have never used the fact that the output of the channel  $y$  was the same for both decoders  $d_1$  and  $d_2$ . This implies that the result also holds for interference channels, i.e. two-sender two-receiver channels  $W(y_1 y_2 | x_2 x_1)$ . Specifically, non-signaling assistance shared between the first sender and the first receiver and independently shared between the second sender and the second receiver does not change the capacity region of interference channels.

## 4.7 Conclusion

In this chapter, we have addressed the computational complexity of the multiple-access channel coding problem, by showing that no polynomial-time constant approximation exists if a complexity hypothesis on random  $k$ -SAT formulas is true. Then, we studied the impact of non-signaling assistance on the capacity of multiple-access channels. We have developed an efficient linear program computing the success probability of the best non-signaling assisted code for a finite number of copies of a multiple-access channel. In particular, this gives lower bounds on the zero-error non-signaling assisted capacity of multiple-access channels. Applied to the binary adder channel, these results were used to prove that a sum-rate of  $\frac{\log_2(72)}{4} \simeq 1.5425$  can be reached with zero error, which beats the maximum classical sum-rate capacity of  $\frac{3}{2}$ . For noisy channels, we have developed a technique giving lower bounds through the use of concatenated codes. Applied to the noisy binary adder channel, this technique was used to show that non-signaling assistance still improves the sum-rate capacity. We have also found an outer bound on the non-signaling assisted capacity region through a relaxed notion of non-signaling assistance, whose capacity region was characterized by a single-letter formula. Finally, we have shown that independent non-signaling assistance does not change the capacity region.

Our results suggest that quantum entanglement may also increase the capacity of such channels. However, even for the binary adder channel, this question remains open. One

could also ask if such efficient methods to compute the best non-signaling assisted codes can be extended to Gaussian multiple-access channels. Finally, establishing a single-letter formula for the non-signaling assisted capacity of multiple-access channels is the main open question left here. It remains open even for the binary adder channel. Proving that non-signaling assistance and relaxed non-signaling assistance coincide asymptotically would directly answer this question and show that the capacity region is described in Theorem [4.25](#).



# Broadcast Channel Coding With Non-Signaling Correlations

Broadcast channels, introduced by Cover in [Cov72], describe the simple network communication setting where one sender aims to transmit individual messages to two receivers. Contrary to point-to-point channels [Sha48] or multiple-access channels [Lia73, Ahl73], the capacity region of broadcast channels is known only for particular classes such as the degraded [Ber73, Gal74, AK75], deterministic [Mar77, Pin78] and semi-deterministic [GP80]. Only inner bounds [Cov75, vdM75, Mar79] and outer bounds [Sat78, Mar79, NG07, GN20] on the capacity region are known in the general setting.

On the one hand, it is natural to ask whether quantum-entanglement or even non-signaling correlations change the capacity region of broadcast channels. It is known that gaps exist between the classical, quantum-entanglement assisted and non-signaling assisted capacity regions of two-sender two-receiver interference channels [QS17] and MACs [LALS20, SLSS22]; see Chapter 4 for a detailed analysis of non-signaling assistance on MACs. However, the influence of nonlocal resources on broadcast channels has been comparably less studied. We only know that quantum entanglement shared between decoders does not change the capacity region [PDB21].

On the other hand, from an algorithmic point of view, a crucial question in information theory is the complexity of the channel coding problem, which entails maximizing the success probability that can be achieved by sending a fixed number of messages over a channel. However, as solving exactly this problem is NP-hard, a natural question that arises is its approximability. For point-to-point channels, Barman and Fawzi found in [BF18] a  $(1 - e^{-1})$ -approximation algorithm running in polynomial time. They showed that it is NP-hard to approximate the channel coding problem in polynomial time for any strictly better ratio. For  $\ell$ -list-decoding, where the decoder is allowed to output a list of  $\ell$  guesses, a polynomial-time approximation algorithm achieving a  $1 - \frac{\ell^\ell e^{-\ell}}{\ell!}$  ratio was found in [BFGG20], and it was shown to be NP-hard to do better in Chapter 3; see Theorem 3.1. For multiple-access channel coding, the complexity of the problem can be linked to the bipartite densest subgraph problem [FKP01], which cannot be approximated within any constant ratio under a complexity hypothesis on random  $k$ -SAT formulas [AAM<sup>+</sup>11]; see Theorem 4.5 from Chapter 4. However, the approximability of broadcast channel coding has not been addressed in the literature.

In the point-to-point scenario studied in [BF18], the existence of a constant-ratio approximation algorithm is linked to the equality of the capacity regions with and without non-signaling assistance. Indeed, giving non-signaling assistance to the channel coding problem turns it into a linear program, thus computable in polynomial time. In fact, it is equal to its natural linear relaxation, which is a common strategy towards approximating an integer linear program. Showing that this approximation strategy guarantees a constant ratio is the key ingredient in proving the equality of the capacity regions with and without non-signaling assistance. This raises the following questions on broadcast channels: Does the capacity region of the broadcast channel change when non-signaling resources between parties are allowed? What is the best approximability ratio of the broadcast channel coding problem? How those two questions are related?

**Contributions** In this chapter, as a first result, we prove that the sum success probabilities of the broadcast channel coding problem are the same with and without non-signaling assistance between decoders; see Theorem 5.4. This strengthens a result by [PDB21] establishing that entanglement between the decoders does not change the capacity region.

The main focus of this chapter is to study the influence of sharing a non-signaling resource between the three parties. Our main result shows that for the class of deterministic broadcast channels, non-signaling resources shared between the three parties does not change the capacity region; see Theorem 5.10 and Corollary 5.11. In order to prove this result, we consider the algorithmic problem of optimal channel coding for a deterministic broadcast channel. For this problem, we describe a  $(1 - e^{-1})^2$ -approximation algorithm running in polynomial time. This is achieved through a graph interpretation of the problem, where one aims at partitioning a bipartite graph into  $k_1$  and  $k_2$  parts, such that the resulting quotient graph is the densest possible; see Proposition 5.7 and Theorem 5.8. To prove our result on the limitations of non-signaling assistance for deterministic broadcast channels, we use the same ideas as the ones involved in the analysis of the approximation algorithm.

As far as hardness is concerned, we consider the subproblem of broadcast channel coding where the number of messages one decoder is responsible of is maximum. This subproblem can be interpreted as a social welfare maximization problem. In the theory of fair division [BT96, Mou03], social welfare maximization entails partitioning a set of goods among agents in order to maximize the sum of their utilities. The social welfare problem has been extensively studied through black box approach [BN05], which led to a precise analysis of achievable approximation ratio as well as hardness results [DS06, MSV08], depending on the class of utility functions considered and the type of black box access to them. We refine the hardness result for the class of fractionally sub-additive utility functions to the subclass coming from the broadcast channel coding subproblem interpretation. Specifically, we show that in the value query model, we cannot achieve a better approximation ratio than  $\Omega\left(\frac{1}{\sqrt{m}}\right)$  in polynomial time, with  $m$  the size of one of the outputs of the channel; see Theorem 5.14. Following the previous discussion on the links between constant-ratio approximation algorithms and non-signaling capacity regions, this hardness result is a first step towards showing that sharing a non-signaling resource between the three parties of a broadcast channel can enlarge its capacity region.

**Organization** In Section 5.1, we define precisely the different versions of the broadcast channel coding problem depending on the choice of objective value, and show that they all lead to the same capacity region. In Section 5.2, we define the different non-signaling

assisted versions of the broadcast channel coding problem. In particular, we show that the sum success probabilities with and without non-signaling assistance shared between decoders are the same, and that it implies that the related capacity regions are the same. In Section 5.3, we address both algorithmic aspects and capacity considerations of deterministic broadcast channels. Specifically, we describe a  $(1 - e^{-1})^2$ -approximation algorithm running in polynomial time for that class, and we show that the capacity region for that class is the same with or without non-signaling assistance. Finally, in Section 5.4, we show that in the value query model, we cannot achieve a better approximation ratio than  $\Omega\left(\frac{1}{\sqrt{m}}\right)$  in polynomial time for the general broadcast channel coding problem, with  $m$  the size of one of the outputs of the channel.

## 5.1 Broadcast Channel Coding

### 5.1.1 Broadcast Channels

The coding problem for a broadcast channel  $W : \mathcal{X} \rightarrow \mathcal{Y}_1 \times \mathcal{Y}_2$  can be stated in the following way. We want to encode a pair of messages belonging to  $[k_1] \times [k_2]$  into  $\mathcal{X}$ . The pair is given as input to  $W$ , which results in two random outputs in  $\mathcal{Y}_1$  and  $\mathcal{Y}_2$ . From the output in  $\mathcal{Y}_1$  (resp.  $\mathcal{Y}_2$ ), we want to decode back the original message in  $[k_1]$  (resp.  $[k_2]$ ). We will call  $e : [k_1] \times [k_2] \rightarrow \mathcal{X}$  the encoder,  $d_1 : \mathcal{Y}_1 \rightarrow [k_1]$  the first decoder and  $d_2 : \mathcal{Y}_2 \rightarrow [k_2]$  the second decoder. The scenario is depicted in Figure 5.1.

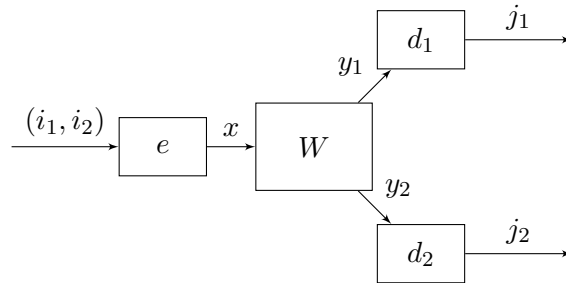

Figure 5.1 – Coding for a broadcast channel  $W$ .

We will call  $p_1(W, e, d_1)$  (resp.  $p_2(W, e, d_2)$ ) the probability of successfully decoding the first (resp. second) message, i.e. that  $j_1 = i_1$  (resp.  $j_2 = i_2$ ), given that the encoder is  $e$  and the decoder is  $d_1$  (resp.  $d_2$ ). We will also consider  $p(W, e, d_1, d_2)$ , the probability of successfully decoding both messages, i.e. that  $j_1 = i_1$  and  $j_2 = i_2$ , given that the encoder is  $e$  and the decoders are  $d_1, d_2$ .

We aim to find the best encoder and decoders according to some figure of merit. However, to do so, we need a one-dimensional real-valued objective to optimize. This leads to two different quantities.

### 5.1.2 The Sum Success Probability $S_{\text{sum}}(W, k_1, k_2)$

We will focus first on maximizing  $\frac{p_1(W, e, d_1) + p_2(W, e, d_2)}{2}$  over all encoders  $e$  and decoders  $d_1, d_2$ . We will call  $S_{\text{sum}}(W, k_1, k_2)$  the resulting maximum sum probability of successfully encoding and decoding the messages through  $W$ , given that the input pair of messages is

taken uniformly in  $[k_1] \times [k_2]$ .  $S_{\text{sum}}(W, k_1, k_2)$  is the solution of the following optimization program:

$$\begin{aligned}
 & \underset{e, d_1, d_2}{\text{maximize}} && \frac{1}{k_1 k_2} \sum_{i_1, i_2, x, y_1, y_2} W(y_1 y_2 | x) e(x | i_1 i_2) \frac{d_1(i_1 | y_1) + d_2(i_2 | y_2)}{2} \\
 & \text{subject to} && \sum_{x \in \mathcal{X}} e(x | i_1 i_2) = 1, \forall i_1 \in [k_1], i_2 \in [k_2] \\
 & && \sum_{j_1 \in [k_1]} d_1(j_1 | y_1) = 1, \forall y_1 \in \mathcal{Y}_1 \\
 & && \sum_{j_2 \in [k_2]} d_2(j_2 | y_2) = 1, \forall y_2 \in \mathcal{Y}_2 \\
 & && e(x | i_1 i_2), d_1(j_1 | y_1), d_2(j_2 | y_2) \geq 0
 \end{aligned} \tag{5.1}$$

*Proof.* One should note that we allow in fact non-deterministic encoders and decoders for generality reasons, although the value of the program is not changed as it is convex. Besides that remark, let us name  $I_1, I_2, J_1, J_2, X, Y_1, Y_2$  the random variables corresponding to  $i_1, i_2, j_1, j_2, x, y_1, y_2$  in the coding and decoding process. Then, given  $e, d_1, d_2$  and  $W$ , the objective value of the previous program comes from:

$$\begin{aligned}
 p_1(W, e, d_1) &= \mathbb{P}(J_1 = I_1) = \frac{1}{k_1 k_2} \sum_{i_1, i_2} \mathbb{P}(J_1 = i_1 | I_1 = i_1, I_2 = i_2) \\
 &= \frac{1}{k_1 k_2} \sum_{i_1, i_2, x} e(x | i_1 i_2) \mathbb{P}(J_1 = i_1 | i_1, i_2, X = x) \\
 &= \frac{1}{k_1 k_2} \sum_{i_1, i_2, x, y_1, y_2} W(y_1 y_2 | x) e(x | i_1 i_2) \mathbb{P}(J_1 = i_1 | i_1, i_2, x, Y_1 = y_1, Y_2 = y_2) \\
 &= \frac{1}{k_1 k_2} \sum_{i_1, i_2, x, y_1, y_2} W(y_1 y_2 | x) e(x | i_1 i_2) d_1(i_1 | y_1),
 \end{aligned} \tag{5.2}$$

and symmetrically for  $p_2(W, e, d_2)$ , which leads to the announced objective value.  $\square$

One can rewrite this optimization program in a more convenient way, proving that  $S_{\text{sum}}(W, k_1, k_2)$  depends only on the marginals of  $W$ :

**Proposition 5.1.**

$$\begin{aligned}
 S_{\text{sum}}(W, k_1, k_2) &= \underset{e, d_1, d_2}{\text{maximize}} && \frac{1}{2k_1 k_2} \sum_{i_1, x, y_1} W_1(y_1 | x) d_1(i_1 | y_1) \sum_{i_2} e(x | i_1 i_2) \\
 &&& + \frac{1}{2k_1 k_2} \sum_{i_2, x, y_2} W_2(y_2 | x) d_2(i_2 | y_2) \sum_{i_1} e(x | i_1 i_2) \\
 & \text{subject to} && \sum_{x \in \mathcal{X}} e(x | i_1 i_2) = 1, \forall i_1 \in [k_1], i_2 \in [k_2] \\
 & && \sum_{j_1 \in [k_1]} d_1(j_1 | y_1) = 1, \forall y_1 \in \mathcal{Y}_1 \\
 & && \sum_{j_2 \in [k_2]} d_2(j_2 | y_2) = 1, \forall y_2 \in \mathcal{Y}_2 \\
 & && e(x | i_1 i_2), d_1(j_1 | y_1), d_2(j_2 | y_2) \geq 0
 \end{aligned} \tag{5.3}$$



*Proof.* It follows from the definitions  $W_1(y_1|x) := \sum_{y_2} W(y_1 y_2|x)$  and  $W_2(y_2|x) := \sum_{y_1} W(y_1 y_2|x)$ .  $\square$

### 5.1.3 The Joint Success Probability $S(W, k_1, k_2)$

We will now focus on maximizing  $p(W, e, d_1, d_2)$  over all encoders  $e$  and decoders  $d_1, d_2$ . We will call  $S(W, k_1, k_2)$  the resulting maximum probability of successfully encoding and decoding the messages through  $W$ , given that the input pair of messages is taken uniformly in  $[k_1] \times [k_2]$ .  $S(W, k_1, k_2)$  is the solution of the following optimization program:

$$\begin{aligned}
 S(W, k_1, k_2) := & \underset{e, d_1, d_2}{\text{maximize}} && \frac{1}{k_1 k_2} \sum_{i_1, i_2, x, y_1, y_2} W(y_1 y_2|x) e(x|i_1 i_2) d_1(i_1|y_1) d_2(i_2|y_2) \\
 & \text{subject to} && \sum_{x \in \mathcal{X}} e(x|i_1 i_2) = 1, \forall i_1 \in [k_1], i_2 \in [k_2] \\
 & && \sum_{j_1 \in [k_1]} d_1(j_1|y_1) = 1, \forall y_1 \in \mathcal{Y}_1 \\
 & && \sum_{j_2 \in [k_2]} d_2(j_2|y_2) = 1, \forall y_2 \in \mathcal{Y}_2 \\
 & && e(x|i_1 i_2), d_1(j_1|y_1), d_2(j_2|y_2) \geq 0
 \end{aligned} \tag{5.4}$$

The proof is the same as in the sum probability scenario. We define the (resp. sum) capacity region using Definition 2.12 by  $\mathcal{C}(W) := \mathcal{C}[S](W)$  (resp.  $\mathcal{C}_{\text{sum}}(W) := \mathcal{C}[S_{\text{sum}}](W)$ ).

The objective values of those two optimization programs are not the same, but  $S(W, k_1, k_2)$  and  $S_{\text{sum}}(W, k_1, k_2)$  still characterize the same capacity region [Wil90]:

**Proposition 5.2.** *For any broadcast channel  $W$ ,  $\mathcal{C}(W) = \mathcal{C}_{\text{sum}}(W)$ .*

*Proof.* Let us focus on error probabilities rather than success ones. Call them respectively  $E(W, k_1, k_2) := 1 - S(W, k_1, k_2)$  and  $E_{\text{sum}}(W, k_1, k_2) := 1 - S_{\text{sum}}(W, k_1, k_2)$ . Let us fix a solution  $e, d_1, d_2$  of the optimization program computing  $S(W, k_1, k_2)$ . Let us remark first that:

$$\sum_{i_1, i_2, x, y_1, y_2} W(y_1 y_2|x) e(x|i_1 i_2) = k_1 k_2,$$

thus, the value of the maximum error for those encoder and decoders is:

$$\begin{aligned}
 E(W, k_1, k_2, e, d_1, d_2) &:= 1 - \frac{1}{k_1 k_2} \left( \sum_{i_1, i_2, x, y_1, y_2} W(y_1 y_2|x) e(x|i_1 i_2) d_1(i_1|y_1) d_2(i_2|y_2) \right) \\
 &= \frac{1}{k_1 k_2} \sum_{i_1, i_2, x, y_1, y_2} W(y_1 y_2|x) e(x|i_1 i_2) \\
 &\quad - \frac{1}{k_1 k_2} \sum_{i_1, i_2, x, y_1, y_2} W(y_1 y_2|x) e(x|i_1 i_2) d_1(i_1|y_1) d_2(i_2|y_2) \\
 &= \frac{1}{k_1 k_2} \left( \sum_{i_1, i_2, x, y_1, y_2} W(y_1 y_2|x) e(x|i_1 i_2) [1 - d_1(i_1|y_1) d_2(i_2|y_2)] \right).
 \end{aligned} \tag{5.5}$$

Similarly, the value of the sum error  $E_{\text{sum}}(W, k_1, k_2, e, d_1, d_2)$  is equal to:

$$\begin{aligned} & 1 - \frac{1}{k_1 k_2} \left( \sum_{i_1, i_2, x, y_1, y_2} W(y_1 y_2 | x) e(x | i_1 i_2) \frac{d_1(i_1 | y_1) + d_2(i_2 | y_2)}{2} \right) \\ &= \frac{1}{k_1 k_2} \left( \sum_{i_1, i_2, x, y_1, y_2} W(y_1 y_2) e(x | i_1 i_2) \left[ 1 - \frac{d_1(i_1 | y_1) + d_2(i_2 | y_2)}{2} \right] \right). \end{aligned} \quad (5.6)$$

However, for  $x, y \in [0, 1]$ , we have that:

$$1 - xy \geq \max(1 - x, 1 - y) \geq 1 - \frac{x + y}{2},$$

and:

$$1 - xy \leq (1 - x) + (1 - y) = 2 \left( 1 - \frac{x + y}{2} \right).$$

This means that, for all  $e, d_1, d_2$ , we have:

$$E_{\text{sum}}(W, k_1, k_2, e, d_1, d_2) \leq E(W, k_1, k_2, e, d_1, d_2) \leq 2E_{\text{sum}}(W, k_1, k_2, e, d_1, d_2),$$

so, maximizing over all  $e, d_1, d_2$ , we get:

$$E_{\text{sum}}(W, k_1, k_2) \leq E(W, k_1, k_2) \leq 2E_{\text{sum}}(W, k_1, k_2).$$

Thus, up to a multiplicative factor 2, the error is the same. In particular, when one of those errors tends to zero, the other one tends to zero as well. This implies that the capacity regions are the same.  $\square$

## 5.2 Non-Signaling Assistance

In this section, we will consider the broadcast channel coding problem with additional resources, in order to determine how these resources affect its success probabilities as well as the capacity regions that can be defined from them.

### 5.2.1 Non-Signaling Assistance Between Decoders

Here, we consider the case where the receivers are given non-signaling assistance. This resource, which is a theoretical but easier to manipulate generalization of quantum entanglement, can be characterized as follows. A non-signaling box  $d(j_1 j_2 | y_1 y_2)$  is any joint conditional probability distribution such that the marginal from one party is independent of the other party's input, i.e. we have:

$$\begin{aligned} \forall j_1, y_1, y_2, y'_2, \quad & \sum_{j_2} d(j_1 j_2 | y_1 y_2) = \sum_{j_2} d(j_1 j_2 | y_1 y'_2), \\ \forall j_2, y_1, y_2, y'_1, \quad & \sum_{j_1} d(j_1 j_2 | y_1 y_2) = \sum_{j_1} d(j_1 j_2 | y'_1 y_2). \end{aligned} \quad (5.7)$$

Thus, when receivers are given non-signaling assistance, the product  $d_1(j_1|y_1)d_2(j_2|y_2)$  is replaced by the non-signaling box  $d(j_1j_2|y_1y_2)$ . Thus, we define the joint and sum success probabilities  $S^{\text{NS}_{\text{dec}}}(W, k_1, k_2)$  (resp.  $S_{\text{sum}}^{\text{NS}_{\text{dec}}}(W, k_1, k_2)$ ) by:

$$\begin{aligned}
 & \underset{e, d_1, d_2}{\text{maximize}} \quad \frac{1}{k_1 k_2} \sum_{i_1, i_2, x, y_1, y_2} W(y_1 y_2 | x) e(x | i_1 i_2) d(i_1 i_2 | y_1 y_2) \\
 & \left( \text{resp. } \underset{e, d_1, d_2}{\text{maximize}} \quad \frac{1}{2k_1 k_2} \sum_{i_1, i_2, x, y_1, y_2} W(y_1 y_2 | x) e(x | i_1 i_2) \sum_{j_2} d(i_1 j_2 | y_1 y_2) \right. \\
 & \quad \left. + \frac{1}{2k_1 k_2} \sum_{i_1, i_2, x, y_1, y_2} W(y_1 y_2 | x) e(x | i_1 i_2) \sum_{j_1} d(j_1 i_2 | y_1 y_2) \right) \\
 & \text{subject to} \quad \sum_x e(x | i_1 i_2) = 1 \\
 & \quad \sum_{j_2} d(j_1 j_2 | y_1 y_2) = \sum_{j_1} d(j_1 j_2 | y_1 y_2') \\
 & \quad \sum_{j_1} d(j_1 j_2 | y_1 y_2) = \sum_{j_1} d(j_1 j_2 | y_1' y_2) \\
 & \quad \sum_{j_1, j_2} d(j_1 j_2 | y_1 y_2) = 1 \\
 & \quad e(x | i_1 i_2), d(j_1 j_2 | y_1 y_2) \geq 0
 \end{aligned} \tag{5.8}$$

The (resp. sum) capacity region with non-signaling assistance between decoders is defined using Definition 2.12 by  $\mathcal{C}^{\text{NS}_{\text{dec}}}(W) := \mathcal{C}[\text{S}^{\text{NS}_{\text{dec}}}] (W)$  (resp.  $\mathcal{C}_{\text{sum}}^{\text{NS}_{\text{dec}}}(W) := \mathcal{C}[\text{S}_{\text{sum}}^{\text{NS}_{\text{dec}}}] (W)$ ).

We will now show that sum and joint capacity regions with non-signaling assistance between decoders are the same.

**Proposition 5.3.** *For any broadcast channel  $W$ ,  $\mathcal{C}_{\text{sum}}^{\text{NS}_{\text{dec}}}(W) = \mathcal{C}^{\text{NS}_{\text{dec}}}(W)$ .*

*Proof.* Given an encoder  $e$  and a non-signaling decoding box  $d$ , the maximum success probability of encoding and decoding correctly with those is given by:

$$S^{\text{NS}_{\text{dec}}}(W, k_1, k_2, e, d) := \frac{1}{k_1 k_2} \sum_{i_1, i_2, x, y_1, y_2} W(y_1 y_2 | x) e(x | i_1 i_2) d(i_1 i_2 | y_1 y_2) .$$

This should be compared to the sum success probability  $S_{\text{sum}}^{\text{NS}_{\text{dec}}}(W, k_1, k_2, e, d)$  of encoding and decoding correctly with those:

$$\frac{1}{k_1 k_2} \sum_{i_1, i_2, x, y_1, y_2} W(y_1 y_2 | x) e(x | i_1 i_2) \left[ \frac{\sum_{j_2} d(i_1 j_2 | y_1 y_2) + \sum_{j_1} d(j_1 i_2 | y_1 y_2)}{2} \right] .$$

Similarly to what was done in Proposition 5.2, we focus on error probabilities rather than success probabilities. This leads again to:

$$E^{\text{NS}_{\text{dec}}}(W, k_1, k_2, e, d) = \frac{1}{k_1 k_2} \sum_{i_1, i_2, x, y_1, y_2} W(y_1 y_2 | x) e(x | i_1 i_2) [1 - d(i_1 i_2 | y_1 y_2)] ,$$

and  $E_{\text{sum}}^{\text{NSdec}}(W, k_1, k_2, e, d)$  equal to:

$$\frac{1}{k_1 k_2} \sum_{i_1, i_2, x, y_1, y_2} W(y_1 y_2 | x) e(x | i_1 i_2) \left[ \frac{1 - \sum_{j_2} d(i_1 j_2 | y_1 y_2)}{2} + \frac{1 - \sum_{j_1} d(j_1 i_2 | y_1 y_2)}{2} \right].$$

But we have that:

$$\begin{aligned} 1 - d(i_1 i_2 | y_1 y_2) &\geq \max \left( 1 - \sum_{j_2} d(i_1 j_2 | y_1 y_2), 1 - \sum_{j_1} d(j_1 i_2 | y_1 y_2) \right) \\ &\geq \frac{1 - \sum_{j_2} d(i_1 j_2 | y_1 y_2)}{2} + \frac{1 - \sum_{j_1} d(j_1 i_2 | y_1 y_2)}{2}, \end{aligned} \quad (5.9)$$

since  $d(j_1 j_2 | y_1 y_2) \in [0, 1]$ , and we have that:

$$\begin{aligned} &1 - \sum_{j_2} d(i_1 j_2 | y_1 y_2) + 1 - \sum_{j_1} d(j_1 i_2 | y_1 y_2) \\ &= 1 - d(i_1 i_2 | y_1 y_2) + 1 - \sum_{(j_1, j_2) \in S} d(j_1 j_2 | y_1 y_2) \\ &\geq 1 - d(i_1 i_2 | y_1 y_2), \end{aligned} \quad (5.10)$$

with  $S := \{(i_1, j_2) : j_2 \in [k_2] - \{i_2\}\} \sqcup \{(j_1, i_2) : j_1 \in [k_1] - \{i_1\}\}$ .

Thus, this implies that:

$$E_{\text{sum}}^{\text{NSdec}}(W, k_1, k_2, e, d) \leq E^{\text{NSdec}}(W, k_1, k_2, e, d) \leq 2E_{\text{sum}}^{\text{NSdec}}(W, k_1, k_2, e, d),$$

and by maximizing over all  $e$  and  $d$ :

$$E_{\text{sum}}^{\text{NSdec}}(W, k_1, k_2) \leq E^{\text{NSdec}}(W, k_1, k_2) \leq 2E_{\text{sum}}^{\text{NSdec}}(W, k_1, k_2).$$

As before, this implies that the capacity regions are the same.  $\square$

We will now prove that sum success probabilities of the broadcast channel coding problem are the same with and without non-signaling assistance between decoders. In particular, this implies that non-signaling resources shared between decoders does not change the capacity region. Note that, after the publication of [PDB21], Pereg et al. added a remark to the arXiv version of their paper that their result stating that entanglement shared between decoders does not change the capacity of a broadcast channel could be generalized to non-signaling assistance. The theorem below strengthens this result showing that non-signaling assistance between the decoders cannot increase the sum success probability even in the one-shot setting and for arbitrary broadcast channels.

**Theorem 5.4.** *For any  $W, k_1, k_2$ , we have  $S_{\text{sum}}(W, k_1, k_2) = S_{\text{sum}}^{\text{NSdec}}(W, k_1, k_2)$ . As a consequence,  $\mathcal{C}(W) = \mathcal{C}^{\text{NSdec}}(W)$ .*

*Proof.* In the sum scenario, since the objective function does not depend on the product  $d_1(j_1 | y_1) d_2(j_2 | y_2)$  but only on the marginals  $d_1(j_1 | y_1)$  and  $d_2(j_2 | y_2)$ , the non-signaling

box won't give additional decoding power. Indeed, for any encoder  $e$  and non-signaling decoding box  $d$ , we have that:

$$\begin{aligned} S_{\text{sum}}^{\text{NSdec}}(W, k_1, k_2, e, d) &:= \frac{1}{2k_1k_2} \sum_{i_1, x, y_1} W_1(y_1|x) \left( \sum_{j_2} d(i_1j_2|y_1y_2) \right) \sum_{i_2} e(x|i_1i_2) \\ &+ \frac{1}{2k_1k_2} \sum_{i_2, x, y_2} W_2(y_2|x) \left( \sum_{j_1} d(j_1i_2|y_1y_2) \right) \sum_{i_1} e(x|i_1i_2). \end{aligned} \quad (5.11)$$

Thus, by choosing  $d_1(j_1|y_1) := \sum_{j_2} d(j_1j_2|y_1y_2)$  and  $d_2(j_2|y_2) := \sum_{j_1} d(j_1j_2|y_1y_2)$ , which are well-defined since  $d$  is a non-signaling box, we have  $S_{\text{sum}}(W, k_1, k_2, e, d_1, d_2) = S_{\text{sum}}^{\text{NSdec}}(W, k_1, k_2, e, d)$ . By optimizing over all  $e$  and  $d$ ,  $S_{\text{sum}}^{\text{NSdec}}(W, k_1, k_2) \leq S_{\text{sum}}(W, k_1, k_2)$ . Since the inequality is obvious in the other direction, as  $d(j_1j_2|y_1y_2) := d_1(j_1|y_1)d_2(j_2|y_2)$  is always a non-signaling box, we have that  $S_{\text{sum}}(W, k_1, k_2) = S_{\text{sum}}^{\text{NSdec}}(W, k_1, k_2)$ . This implies in particular that the capacity regions are the same, i.e.  $\mathcal{C}_{\text{sum}}(W) = \mathcal{C}_{\text{sum}}^{\text{NSdec}}(W)$

Finally, since  $\mathcal{C}(W) = \mathcal{C}_{\text{sum}}(W)$  by Proposition 5.2 and  $\mathcal{C}_{\text{sum}}^{\text{NSdec}}(W) = \mathcal{C}^{\text{NSdec}}(W)$  by Proposition 5.3, we get that  $\mathcal{C}(W) = \mathcal{C}^{\text{NSdec}}(W)$ .  $\square$

### 5.2.2 Full Non-Signaling Assistance

In this section, we will consider the case where the sender and the receivers are given non-signaling assistance. This means that a three-party non-signaling box  $P(xj_1j_2|(i_1i_2)y_1y_2)$  will replace the product  $e(x|i_1i_2)d_1(j_1|y_1)d_2(j_2|y_2)$  in the previous objective values. A joint conditional probability  $P(xj_1j_2|(i_1i_2)y_1y_2)$  is a non-signaling box if the marginal from any two parties is independent of the removed party's input:

$$\begin{aligned} \forall j_1, j_2, i_1, i_2, y_1, y_2, i'_1, i'_2, \quad &\sum_x P(xj_1j_2|(i_1i_2)y_1y_2) = \sum_x P(xj_1j_2|(i'_1i'_2)y_1y_2), \\ \forall x, j_2, i_1, i_2, y_1, y_2, y'_1, \quad &\sum_{j_1} P(xj_1j_2|(i_1i_2)y_1y_2) = \sum_{j_1} P(xj_1j_2|(i_1i_2)y'_1y_2), \\ \forall x, j_1, i_1, i_2, y_1, y_2, y'_2, \quad &\sum_{j_2} P(xj_1j_2|(i_1i_2)y_1y_2) = \sum_{j_2} P(xj_1j_2|(i_1i_2)y_1y'_2). \end{aligned} \quad (5.12)$$

The scenario is depicted in Figure 5.2.

The cyclicity of Figure 5.2 is at first sight counter-intuitive. Note first that  $P$  being a non-signaling box is completely independent of  $W$ : in particular, the variables  $y_1, y_2$  do not need to follow any laws in the definition of  $P$  being a non-signaling box. Therefore, the remaining ambiguity is the apparent need to encode and decode at the same time. However, since  $P$  is a non-signaling box, we won't need to do both at the same time, although the global correlation between the sender and the receivers will be characterized only by  $P(xj_1j_2|(i_1i_2)y_1y_2)$ . Indeed,  $\forall y_1, y_2, P(x|(i_1i_2)) = P(x|(i_1i_2)y_1y_2)$  by the non-signaling property of  $P$ . Thus, one can get the output  $x$  on input  $(i_1i_2)$  without access to  $y_1, y_2$ , as that knowledge won't affect the law of  $x$ . Then  $(y_1, y_2)$  follows the law given by  $W$  given that  $x$ . Finally, given access to  $y_1, y_2$ , the decoding process is described by:

$$P(j_1j_2|(i_1i_2)y_1y_2x) = \frac{P(xj_1j_2|(i_1i_2)y_1y_2)}{P(x|(i_1i_2)y_1y_2)} = \frac{P(xj_1j_2|(i_1i_2)y_1y_2)}{P(x|(i_1i_2))},$$

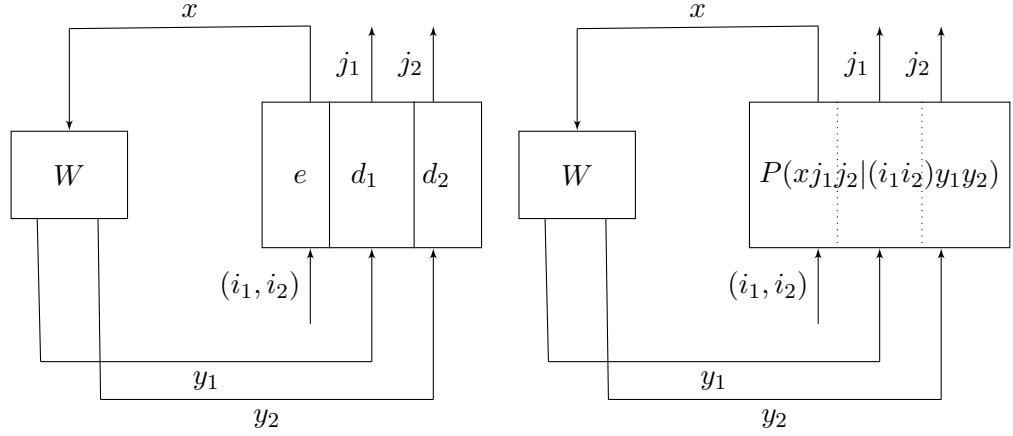

Figure 5.2 – A non-signaling box  $P$  replacing  $e, d_1, d_2$  in the coding problem for the broadcast channel  $W$ .

so we recover  $P(j_1 j_2 | (i_1 i_2) y_1 y_2 x) \times P(x | (i_1 i_2)) = P(x j_1 j_2 | (i_1 i_2) y_1 y_2)$ , and therefore, the process is not cyclic. Non-signaling boxes define exactly the conditional probability distributions where it is possible to consider the conditional probabilities of each party independently. This clarifies how one can effectively encode and then decode messages through a non-signaling box.

We will call the maximum sum success probability  $S_{\text{sum}}^{\text{NS}}(W, k_1, k_2)$ , which is given by the following linear program, where the constraints translate precisely the fact that  $P$  is a non-signaling box:

$$\begin{aligned}
 S_{\text{sum}}^{\text{NS}}(W, k_1, k_2) := & \underset{P}{\text{maximize}} && \frac{1}{2k_1 k_2} \sum_{i_1, x, y_1} W_1(y_1 | x) \sum_{i_2, j_2} P(x i_1 j_2 | (i_1 i_2) y_1 y_2) \\
 & + && \frac{1}{2k_1 k_2} \sum_{i_2, x, y_2} W_2(y_2 | x) \sum_{i_1, j_1} P(x j_1 i_2 | (i_1 i_2) y_1 y_2) \\
 & \text{subject to} && \sum_x P(x j_1 j_2 | (i_1 i_2) y_1 y_2) = \sum_x P(x j_1 j_2 | (i'_1 i'_2) y_1 y_2) \\
 & && \sum_{j_1} P(x j_1 j_2 | (i_1 i_2) y_1 y_2) = \sum_{j_1} P(x j_1 j_2 | (i_1 i_2) y'_1 y_2) \\
 & && \sum_{j_2} P(x j_1 j_2 | (i_1 i_2) y_1 y_2) = \sum_{j_2} P(x j_1 j_2 | (i_1 i_2) y_1 y'_2) \\
 & && \sum_{x, j_1, j_2} P(x j_1 j_2 | (i_1 i_2) y_1 y_2) = 1 \\
 & && P(x j_1 j_2 | (i_1 i_2) y_1 y_2) \geq 0
 \end{aligned} \tag{5.13}$$

Since it is given as a linear program, the complexity of computing  $S_{\text{sum}}^{\text{NS}}(W, k_1, k_2)$  is polynomial in the number of variables and constraints (see for instance Section 7.1 of [GM07]), which is a polynomial in  $|\mathcal{X}|, |\mathcal{Y}_1|, |\mathcal{Y}_2|, k_1$  and  $k_2$ .

Similarly, we define the maximum joint success probability  $S^{\text{NS}}(W, k_1, k_2)$  in the following

way:

$$\begin{aligned}
 S^{\text{NS}}(W, k_1, k_2) := & \underset{P}{\text{maximize}} \quad \frac{1}{k_1 k_2} \sum_{i_1, i_2, x, y_1, y_2} W(y_1 y_2 | x) P(x i_1 i_2 | (i_1 i_2) y_1 y_2) \\
 & \text{subject to} \quad \sum_x P(x j_1 j_2 | (i_1 i_2) y_1 y_2) = \sum_x P(x j_1 j_2 | (i'_1 i'_2) y_1 y_2) \\
 & \quad \sum_{j_1} P(x j_1 j_2 | (i_1 i_2) y_1 y_2) = \sum_{j_1} P(x j_1 j_2 | (i_1 i_2) y'_1 y_2) \\
 & \quad \sum_{j_2} P(x j_1 j_2 | (i_1 i_2) y_1 y_2) = \sum_{j_2} P(x j_1 j_2 | (i_1 i_2) y_1 y'_2) \\
 & \quad \sum_{x, j_1, j_2} P(x j_1 j_2 | (i_1 i_2) y_1 y_2) = 1 \\
 & \quad P(x j_1 j_2 | (i_1 i_2) y_1 y_2) \geq 0
 \end{aligned} \tag{5.14}$$

We can rewrite both these programs in more convenient and smaller linear programs:

**Proposition 5.5.**

$$\begin{aligned}
 S_{\text{sum}}^{\text{NS}}(W, k_1, k_2) = & \underset{p, r, r^1, r^2}{\text{maximize}} \quad \frac{1}{2k_1 k_2} \left( \sum_{x, y_1} W_1(y_1 | x) r_{x, y_1}^1 + \sum_{x, y_2} W_2(y_2 | x) r_{x, y_2}^2 \right) \\
 & \text{subject to} \quad \sum_x r_{x, y_1, y_2} = 1 \\
 & \quad \sum_x r_{x, y_1}^1 = k_2 \\
 & \quad \sum_x r_{x, y_2}^2 = k_1 \\
 & \quad \sum_x p_x = k_1 k_2 \\
 & \quad 0 \leq r_{x, y_1, y_2} \leq r_{x, y_1}^1, r_{x, y_2}^2 \leq p_x \\
 & \quad p_x - r_{x, y_1}^1 - r_{x, y_2}^2 + r_{x, y_1, y_2} \geq 0
 \end{aligned} \tag{5.15}$$

$$\begin{aligned}
 S^{\text{NS}}(W, k_1, k_2) = & \underset{p, r, r^1, r^2}{\text{maximize}} \quad \frac{1}{k_1 k_2} \sum_{x, y_1, y_2} W(y_1 y_2 | x) r_{x, y_1, y_2} \\
 & \text{subject to} \quad \sum_x r_{x, y_1, y_2} = 1 \\
 & \quad \sum_x r_{x, y_1}^1 = k_2 \\
 & \quad \sum_x r_{x, y_2}^2 = k_1 \\
 & \quad \sum_x p_x = k_1 k_2 \\
 & \quad 0 \leq r_{x, y_1, y_2} \leq r_{x, y_1}^1, r_{x, y_2}^2 \leq p_x \\
 & \quad p_x - r_{x, y_1}^1 - r_{x, y_2}^2 + r_{x, y_1, y_2} \geq 0
 \end{aligned} \tag{5.16}$$

*Proof.* One can check that given a solution of the original program, the following choice of variables is a valid solution of the second program achieving the same objective value:

$$\begin{aligned}
 r_{x,y_1,y_2} &:= \sum_{i_1,i_2} P(xi_1i_2|(i_1i_2)y_1y_2) , \\
 r_{x,y_1}^1 &:= \sum_{j_2,i_1,i_2} P(xi_1j_2|(i_1i_2)y_1y_2) , \\
 r_{x,y_2}^2 &:= \sum_{j_1,i_1,i_2} P(xj_1i_2|(i_1i_2)y_1y_2) , \\
 p_x &:= \sum_{j_1,j_2,i_1,i_2} P(xj_1j_2|(i_1i_2)y_1y_2) .
 \end{aligned} \tag{5.17}$$

For the other direction, given those variables, a non-signaling probability distribution  $P(xj_1j_2|(i_1i_2)y_1y_2)$  is given by, for  $j_1 \neq i_1$  and  $j_2 \neq i_2$ :

$$\begin{aligned}
 P(xi_1i_2|(i_1i_2)y_1y_2) &= \frac{r_{x,y_1,y_2}}{k_1k_2} , \\
 P(xj_1i_2|(i_1i_2)y_1y_2) &= \frac{r_{x,y_2}^2 - r_{x,y_1,y_2}}{k_1k_2(k_1 - 1)} , \\
 P(xi_1j_2|(i_1i_2)y_1y_2) &= \frac{r_{x,y_1}^1 - r_{x,y_1,y_2}}{k_1k_2(k_2 - 1)} , \\
 P(xj_1j_2|(i_1i_2)y_1y_2) &= \frac{p_x - r_{x,y_1}^1 - r_{x,y_2}^2 + r_{x,y_1,y_2}}{k_1k_2(k_1 - 1)(k_2 - 1)} .
 \end{aligned} \tag{5.18}$$

□

As before, we define the (resp. sum) capacity region with non-signaling assistance using Definition 2.12 by  $\mathcal{C}^{\text{NS}}(W) := \mathcal{C}[\text{S}^{\text{NS}}](W)$  (resp.  $\mathcal{C}_{\text{sum}}^{\text{NS}}(W) := \mathcal{C}[\text{S}_{\text{sum}}^{\text{NS}}](W)$ ).

**Proposition 5.6.** *For any broadcast channel  $W$ ,  $\mathcal{C}^{\text{NS}}(W) = \mathcal{C}_{\text{sum}}^{\text{NS}}(W)$ .*

*Proof.* Let us show that:

$$2\text{S}_{\text{sum}}^{\text{NS}}(W, k_1, k_2) - 1 \leq \text{S}^{\text{NS}}(W, k_1, k_2) \leq \text{S}_{\text{sum}}^{\text{NS}}(W, k_1, k_2) .$$

This will imply in particular that:

$$\lim_{n \rightarrow +\infty} \text{S}^{\text{NS}}(W^{\otimes n}, \lceil 2^{R_1 n} \rceil, \lceil 2^{R_2 n} \rceil) = 1 \iff \lim_{n \rightarrow +\infty} \text{S}_{\text{sum}}^{\text{NS}}(W^{\otimes n}, \lceil 2^{R_1 n} \rceil, \lceil 2^{R_2 n} \rceil) = 1 ,$$

thus define the same capacity region.

Let us consider an optimal solution  $p_x, r_{x,y_1,y_2}, r_{x,y_1}^1, r_{x,y_2}^2$  of the program computing  $\text{S}_{\text{sum}}^{\text{NS}}(W, k_1, k_2)$ . We have:

$$\text{S}_{\text{sum}}^{\text{NS}}(W, k_1, k_2) = \frac{1}{k_1k_2} \left( \sum_{x,y_1,y_2} W(y_1y_2|x) \frac{r_{x,y_1}^1 + r_{x,y_2}^2}{2} \right) .$$



However  $r_{x,y_1}^1 + r_{x,y_2}^2 \leq p_x + r_{x,y_1,y_2}$  so we get that:

$$\begin{aligned} S_{\text{sum}}^{\text{NS}}(W, k_1, k_2) &\leq \frac{1}{2k_1k_2} \left( \sum_{x,y_1,y_2} W(y_1y_2|x) (p_x + r_{x,y_1,y_2}) \right) \\ &= \frac{1}{2} + \frac{1}{2} \left[ \frac{1}{k_1k_2} \left( \sum_{x,y_1,y_2} W(y_1y_2|x) r_{x,y_1,y_2} \right) \right] \\ &\leq \frac{1}{2} + \frac{1}{2} S^{\text{NS}}(W, k_1, k_2), \end{aligned} \quad (5.19)$$

since  $p_x, r_{x,y_1,y_2}, r_{x,y_1}^1, r_{x,y_2}^2$  is a valid solution of the program computing  $S^{\text{NS}}(W, k_1, k_2)$ .

On the other hand, consider now  $p_x, r_{x,y_1,y_2}, r_{x,y_1}^1, r_{x,y_2}^2$  an optimal solution of the program computing  $S^{\text{NS}}(W, k_1, k_2)$ . We have that  $r_{x,y_1,y_2} \leq r_{x,y_1}^1, r_{x,y_2}^2$  so we have that  $r_{x,y_1,y_2} \leq \frac{r_{x,y_1}^1 + r_{x,y_2}^2}{2}$  and thus:

$$\begin{aligned} S^{\text{NS}}(W, k_1, k_2) &= \frac{1}{k_1k_2} \left( \sum_{x,y_1,y_2} W(y_1y_2|x) r_{x,y_1,y_2} \right) \\ &\leq \frac{1}{k_1k_2} \left( \sum_{x,y_1,y_2} W(y_1y_2|x) \frac{r_{x,y_1}^1 + r_{x,y_2}^2}{2} \right) \\ &\leq S_{\text{sum}}^{\text{NS}}(W, k_1, k_2), \end{aligned} \quad (5.20)$$

since  $p_x, r_{x,y_1,y_2}, r_{x,y_1}^1, r_{x,y_2}^2$  is a valid solution of the program computing  $S_{\text{sum}}^{\text{NS}}(W, k_1, k_2)$ . This prove the inequalities  $2S_{\text{sum}}^{\text{NS}}(W, k_1, k_2) - 1 \leq S^{\text{NS}}(W, k_1, k_2) \leq S_{\text{sum}}^{\text{NS}}(W, k_1, k_2)$ , and thus concludes the proof.  $\square$

### 5.3 Approximation Algorithm for Deterministic Broadcast Channel Coding

In this section, we will address the question of the approximability of  $S(W, k_1, k_2)$ , in the restricted scenario of a deterministic broadcast channel  $W$ . Specifically, we study the problem of finding a code  $e : [k_1] \times [k_2] \rightarrow \mathcal{X}$ ,  $d_1 : \mathcal{Y}_1 \rightarrow [k_1]$ ,  $d_2 : \mathcal{Y}_2 \rightarrow [k_2]$  that maximizes the program computing  $S(W, k_1, k_2)$ . Note that the restriction to deterministic codes does not affect the value of the objective of the program which is convex, and that the problem is as hard as finding any code maximizing the program computing  $S(W, k_1, k_2)$ , as a deterministic code with a better or equal value can be retrieved easily from any code.

We say that  $W$  is deterministic if  $\forall x, y_1, y_2, W(y_1y_2|x) \in \{0, 1\}$ . We can then define  $(W_1(x), W_2(x))$  as the only pair  $(y_1, y_2)$  such that  $W(y_1y_2|x) = 1$ , which exists uniquely as  $W$  is a conditional probability distribution. Thus, the deterministic broadcast channel coding problem can be defined in the following way:

**Definition 5.1 (DETBC).** Given a deterministic channel  $W$  and integers  $k_1$  and  $k_2$ , the deterministic broadcast channel coding problem, which we call DETBC, entails maximizing

$$S(W, k_1, k_2, e, d_1, d_2) := \frac{1}{k_1k_2} \sum_{i_1, i_2} \mathbb{1}_{d_1(W_1(e(i_1i_2)))=i_1} \mathbb{1}_{d_2(W_2(e(i_1i_2)))=i_2}$$

over all functions  $e : [k_1] \times [k_2] \rightarrow \mathcal{X}$ ,  $d_1 : \mathcal{Y}_1 \rightarrow [k_1]$ ,  $d_2 : \mathcal{Y}_2 \rightarrow [k_2]$ .

### 5.3.1 Reformulation as a Bipartite Graph Problem

We will reformulate DETBCC as a bipartite graph problem. But first, let us introduce some notations:

**Definition 5.2** (Graph notations). Consider a bipartite graph  $G = (V_1 \sqcup V_2, E \subseteq V_1 \times V_2)$ :

1.  $G^{\mathcal{P}_1, \mathcal{P}_2}$ , the quotient of  $G$  by partitions  $\mathcal{P}_1, \mathcal{P}_2$  of respectively  $V_1, V_2$ , is defined by:

$$G^{\mathcal{P}_1, \mathcal{P}_2} := (\mathcal{P}_1 \sqcup \mathcal{P}_2, \{(p_1, p_2) \in \mathcal{P}_1 \times \mathcal{P}_2 : E \cap (p_1 \times p_2) \neq \emptyset\}) .$$

2.  $e_G(\mathcal{P}_1, \mathcal{P}_2) := |E^{G^{\mathcal{P}_1, \mathcal{P}_2}}|$  is the number of edges of  $G^{\mathcal{P}_1, \mathcal{P}_2}$ .
3.  $N_G^{\mathcal{P}_1, \mathcal{P}_2}(p) := N_{G^{\mathcal{P}_1, \mathcal{P}_2}}(p)$  is the set of neighbors of  $p$  in the graph  $G^{\mathcal{P}_1, \mathcal{P}_2}$ .
4. Similarly,  $\deg_G^{\mathcal{P}_1, \mathcal{P}_2}(p) := \deg_{G^{\mathcal{P}_1, \mathcal{P}_2}}(p)$  is the degree, i.e. the number of neighbors, of  $p$  in the graph  $G^{\mathcal{P}_1, \mathcal{P}_2}$ .
5. We will use  $V_1, V_2$  in previous notations when we do not partition on the left and right part respectively (or identify those to trivial partitions in singletons). For instance,  $G^{V_1, V_2} = G$ .
6. We will use the notations  $e(\mathcal{P}_1, \mathcal{P}_2)$ ,  $N_{\mathcal{P}_1, \mathcal{P}_2}(p)$  and  $\deg_{\mathcal{P}_1, \mathcal{P}_2}(p)$  when the graph  $G$  considered is clear from context.

Now, let us remark that a deterministic channel  $W$ , up to a permutation of elements of  $\mathcal{X}$ , is characterized by the following bipartite graph:

**Definition 5.3** (Bipartite Graph  $G_W$  associated with the deterministic channel  $W$ ).

$$G_W := (\mathcal{Y}_1 \sqcup \mathcal{Y}_2, E = \{(y_1, y_2) \in \mathcal{Y}_1 \times \mathcal{Y}_2 : \exists x \in \mathcal{X}, y_1 = W_1(x) \text{ and } y_2 = W_2(x)\}) .$$

Indeed, permuting the elements of  $\mathcal{X}$  does not change  $G_W$  nor  $S(W, k_1, k_2)$ . As a consequence, up to a multiplicative factor  $k_1 k_2$ , we will show that DETBCC is equivalent to the following bipartite graph problem:

**Definition 5.4** (DENSESTQUOTIENTGRAPH). Given a bipartite graph  $G = (V_1 \sqcup V_2, E)$  and integers  $k_1, k_2$ , the problem DENSESTQUOTIENTGRAPH entails maximizing  $e_G(\mathcal{P}_1, \mathcal{P}_2)$ , the number of edges of the quotient graph of  $G$  by  $\mathcal{P}_1, \mathcal{P}_2$ , over all partitions  $\mathcal{P}_1$  of  $V_1$  in  $k_1$  parts and  $\mathcal{P}_2$  of  $V_2$  in  $k_2$  parts.

**Proposition 5.7.** *Given a deterministic channel  $W$  and integers  $k_1, k_2$ , it is equivalent to solve DETBCC on  $W, k_1, k_2$  or DENSESTQUOTIENTGRAPH on  $G_W, k_1, k_2$ . That is to say, given an optimal solution of one of those problems, one can efficiently construct an optimal solution of the other. Furthermore, their optimal values satisfy  $k_1 k_2 \text{DET BCC}(W, k_1, k_2) = \text{DENSESTQUOTIENTGRAPH}(G_W, k_1, k_2)$ .*

*Proof.* Consider an optimal solution  $e, d_1, d_2$  of DETBCC. Note that  $d_1$  defines a partition  $\mathcal{P}_1$  of  $\mathcal{Y}_1$  in  $k_1$  parts and  $d_2$  defines a partition  $\mathcal{P}_2$  of  $\mathcal{Y}_2$  in  $k_2$  parts, with  $\mathcal{P}_b^{i_b} := \{y_b \in \mathcal{Y}_b : \dots\}$

$d_b(y) = i_b$  for  $b \in \{1, 2\}$ . Then we have:

$$\begin{aligned} k_1 k_2 S(W, k_1, k_2, e, d_1, d_2) &= \sum_{i_1, i_2} \mathbb{1}_{i_1=d_1(W_1(e(i_1, i_2)))} \mathbb{1}_{i_2=d_2(W_2(e(i_1, i_2)))} \\ &= \sum_{i_1, i_2} \mathbb{1}_{W_1(e(i_1, i_2)) \in \mathcal{P}_1^{i_1}} \mathbb{1}_{W_2(e(i_1, i_2)) \in \mathcal{P}_2^{i_2}} . \end{aligned} \quad (5.21)$$

However, since we consider an optimal solution, we have that:

$$\mathbb{1}_{W_1(e(i_1, i_2)) \in \mathcal{P}_1^{i_1}} \mathbb{1}_{W_2(e(i_1, i_2)) \in \mathcal{P}_2^{i_2}} = \max_{x \in \mathcal{X}} \mathbb{1}_{W_1(x) \in \mathcal{P}_1^{i_1}} \mathbb{1}_{W_2(x) \in \mathcal{P}_2^{i_2}} ,$$

as  $e(i_1, i_2)$  appears only here in the objective value. Thus:

$$\begin{aligned} k_1 k_2 S(W, k_1, k_2, e, d_1, d_2) &= \sum_{i_1, i_2} \max_{x \in \mathcal{X}} \mathbb{1}_{W_1(x) \in \mathcal{P}_1^{i_1}} \mathbb{1}_{W_2(x) \in \mathcal{P}_2^{i_2}} \\ &= \sum_{i_1, i_2} \mathbb{1}_{\exists (y_1, y_2) \in E^{GW} : y_1 \in \mathcal{P}_1^{i_1} \text{ and } y_2 \in \mathcal{P}_2^{i_2}} \\ &= \sum_{i_1, i_2} \mathbb{1}_{E^{GW} \cap (\mathcal{P}_1^{i_1} \times \mathcal{P}_2^{i_2}) \neq \emptyset} \\ &= e_{GW}(\mathcal{P}_1, \mathcal{P}_2) , \end{aligned} \quad (5.22)$$

which proves that given an optimal solution of DETBCC, one can efficiently construct a solution  $\mathcal{P}_1, \mathcal{P}_2$  of DENSESTQUOTIENTGRAPH such that:

$$e_{GW}(\mathcal{P}_1, \mathcal{P}_2) = k_1 k_2 \text{DET BCC}(W, k_1, k_2) .$$

For the other direction, consider an optimal solution  $\mathcal{P}_1, \mathcal{P}_2$  of DENSESTQUOTIENTGRAPH. We have as before that:

$$e_{GW}(\mathcal{P}_1, \mathcal{P}_2) = \sum_{i_1, i_2} \max_{x \in \mathcal{X}} \mathbb{1}_{W_1(x) \in \mathcal{P}_1^{i_1}} \mathbb{1}_{W_2(x) \in \mathcal{P}_2^{i_2}} .$$

Now, let us define  $e(i_1, i_2) \in \operatorname{argmax}_{x \in \mathcal{X}} \mathbb{1}_{W_1(x) \in \mathcal{P}_1^{i_1}} \mathbb{1}_{W_2(x) \in \mathcal{P}_2^{i_2}}$  and  $d_b(y_b)$  the index  $i_b$  such that  $y_b \in \mathcal{P}_b^{i_b}$ , for  $b \in \{1, 2\}$ . With those definitions, we get again that:

$$\begin{aligned} \max_{x \in \mathcal{X}} \mathbb{1}_{W_1(x) \in \mathcal{P}_1^{i_1}} \mathbb{1}_{W_2(x) \in \mathcal{P}_2^{i_2}} &= \mathbb{1}_{W_1(e(i_1, i_2)) \in \mathcal{P}_1^{i_1}} \mathbb{1}_{W_2(e(i_1, i_2)) \in \mathcal{P}_2^{i_2}} \\ &= \mathbb{1}_{i_1=d_1(W_1(e(i_1, i_2)))} \mathbb{1}_{i_2=d_2(W_2(e(i_1, i_2)))} , \end{aligned} \quad (5.23)$$

and thus we have:

$$\begin{aligned} e_{GW}(\mathcal{P}_1, \mathcal{P}_2) &= \sum_{i_1, i_2} \max_{x \in \mathcal{X}} \mathbb{1}_{W_1(x) \in \mathcal{P}_1^{i_1}} \mathbb{1}_{W_2(x) \in \mathcal{P}_2^{i_2}} \\ &= \sum_{i_1, i_2} \mathbb{1}_{i_1=d_1(W_1(e(i_1, i_2)))} \mathbb{1}_{i_2=d_2(W_2(e(i_1, i_2)))} \\ &= k_1 k_2 S(W, k_1, k_2, e, d_1, d_2) , \end{aligned} \quad (5.24)$$

which proves that given an optimal solution of DENSESTQUOTIENTGRAPH, one can efficiently construct a solution  $e, d_1, d_2$  of DETBCC such that:

$$k_1 k_2 S(W, k_1, k_2, e, d_1, d_2) = \text{DENSESTQUOTIENTGRAPH}(G_W, k_1, k_2) .$$

In particular, this implies that the optimal objective values satisfy:

$$k_1 k_2 \text{DET BCC}(W, k_1, k_2) = \text{DENSEST QUOTIENT GRAPH}(G_W, k_1, k_2).$$

Therefore, the solutions of both problems constructed throughout the proof are in fact optimal.  $\square$

*Remark.* Note that all bipartite graphs can be written as  $G_W$  for some deterministic broadcast channel  $W$ , with  $W$  unique up to a permutation of  $\mathcal{X}$ .

### 5.3.2 Approximation Algorithm for DENSEST QUOTIENT GRAPH

In this section, we will sort out how hard is DENSEST QUOTIENT GRAPH, and thanks to Proposition 5.7, how hard is it to solve DET BCC.

**Theorem 5.8.** *There exists a polynomial-time  $(1 - e^{-1})^2$ -approximation algorithm for DENSEST QUOTIENT GRAPH. Furthermore, it is NP-hard to solve exactly DENSEST QUOTIENT GRAPH.*

**Corollary 5.9.** *There exists a polynomial-time  $(1 - e^{-1})^2$ -approximation algorithm for DET BCC. Furthermore, it is NP-hard to solve exactly DET BCC.*

The approximation algorithm is a two-step process. First, we consider the problem of maximizing  $\sum_{i_2=1}^{k_2} \min(k_1, \deg_{V_1, \mathcal{P}_2}(\mathcal{P}_2^{i_2}))$  over all partitions  $\mathcal{P}_2$  of  $V_2$  in  $k_2$  parts. We will show that this is a special case of the submodular welfare problem, which can be approximated within a factor  $1 - e^{-1}$  in polynomial time [Von08]. We then choose the partition  $\mathcal{P}_1$  on  $V_1$  in  $k_1$  parts uniformly at random. This partition pair will give an objective value  $e(\mathcal{P}_1, \mathcal{P}_2)$  within a  $(1 - e^{-1})^2$  factor from the optimal solution in expectation.

*Proof of Theorem 5.8.* Consider first the hardness result. Let us show that the decision version of DENSEST QUOTIENT GRAPH is NP-complete. It is in NP, the certificate being the two partitions and the selection of edges between those partitions. It is NP-hard as one of its particular cases is the SET SPLITTING problem (see for instance [GJ79]), in the case where  $k_1 = 2$  and  $k_2 = |V_2|$ , by interpreting the neighbors of  $v_2 \in V_2$  as a set covering elements of  $V_1$ .

We will show nonetheless that this problem can be approximated within a factor  $(1 - e^{-1})^2$  in polynomial time. First we consider the case where  $k_2 = |V_2|$ . We can then always assume that the right partition is  $\mathcal{P}_2 := \{\{v_2\} : v_2 \in V_2\}$ , which leads necessarily to a greater or equal number of edges in the quotient graph than with any other right partition. So, in that setting, we only need to find a partition of  $V_1$  in  $k_1$  parts maximizing the number of edges between vertices in the right part and the quotient of the left vertices.

First, the maximum value we can get is upper bounded by  $\sum_{v_2 \in V_2} \min(k_1, \deg(v_2))$ . Indeed, each vertex of  $v_2$  can be connected at most to the  $k_1$  parts of  $V_1$ , so its contribution is bounded by  $k_1$ , and there needs to be an edge to each part it is connected, so its contribution is also bounded by  $\deg(v_2)$ . Let us show that if we take a partition  $\mathcal{P}_1$  of  $V_1$  uniformly at random, we get:

$$\begin{aligned} \mathbb{E}_{\mathcal{P}_1}[e(\mathcal{P}_1, V_2)] &\geq \left(1 - \left(1 - \frac{1}{k_1}\right)^{k_1}\right) \sum_{v_2 \in V_2} \min(k_1, \deg(v_2)) \\ &\geq (1 - e^{-1}) \max_{\mathcal{P}_1} e(\mathcal{P}_1, V_2). \end{aligned} \tag{5.25}$$

### 5.3. Approximation Algorithm for Deterministic Broadcast Channel Coding

We have  $e(\mathcal{P}_1, V_2) = \sum_{v_2 \in V_2} \deg_{\mathcal{P}_1, V_2}(v_2)$ , so by linearity of expectation  $\mathbb{E}_{\mathcal{P}_1}[e(\mathcal{P}_1, V_2)] = \sum_{v_2 \in V_2} \mathbb{E}_{\mathcal{P}_1}[\deg_{\mathcal{P}_1, V_2}(v_2)]$ . However  $\deg_{\mathcal{P}_1, V_2}(v_2) = |\{i_1 \in [k_1] : N(v_2) \cap \mathcal{P}_1^{i_1} \neq \emptyset\}|$ . Recall also that for any  $v_1$ ,  $\mathbb{P}(v_1 \in \mathcal{P}_1^{i_1}) = \frac{1}{k_1}$  since the partition is taken uniformly at random. Thus, we get:

$$\begin{aligned}
 \mathbb{E}_{\mathcal{P}_1}[\deg_{\mathcal{P}_1, V_2}(v_2)] &= \mathbb{E}_{\mathcal{P}_1} \left[ |\{i_1 \in [k_1] : N(v_2) \cap \mathcal{P}_1^{i_1} \neq \emptyset\}| \right] = \mathbb{E}_{\mathcal{P}_1} \left[ \sum_{i_1=1}^{k_1} \mathbb{1}_{N(v_2) \cap \mathcal{P}_1^{i_1} \neq \emptyset} \right] \\
 &= \sum_{i_1=1}^{k_1} \mathbb{E}_{\mathcal{P}_1} \left[ \mathbb{1}_{N(v_2) \cap \mathcal{P}_1^{i_1} \neq \emptyset} \right] = \sum_{i_1=1}^{k_1} \mathbb{P} \left( N(v_2) \cap \mathcal{P}_1^{i_1} \neq \emptyset \right) \\
 &= \sum_{i_1=1}^{k_1} \left( 1 - \mathbb{P} \left( N(v_2) \cap \mathcal{P}_1^{i_1} = \emptyset \right) \right) \\
 &= \sum_{i_1=1}^{k_1} \left( 1 - \prod_{v_1 \in N(v_2)} \mathbb{P} \left( v_1 \notin \mathcal{P}_1^{i_1} \right) \right) \\
 &= \sum_{i_1=1}^{k_1} \left( 1 - \prod_{v_1 \in N(v_2)} \mathbb{P} \left( v_1 \notin \mathcal{P}_1^{i_1} \right) \right) = k_1 \left( 1 - \left( 1 - \frac{1}{k_1} \right)^{\deg(v_2)} \right), \tag{5.26}
 \end{aligned}$$

since  $\mathbb{P}(v_1 \notin \mathcal{P}_1^{i_1}) = 1 - \frac{1}{k_1}$  and  $|N(v_2)| = \deg(v_2)$ . So, in all:

$$\mathbb{E}_{\mathcal{P}_1}[e(\mathcal{P}_1, V_2)] = \sum_{v_2 \in V_2} \mathbb{E}_{\mathcal{P}_1}[\deg_{\mathcal{P}_1, V_2}(v_2)] = k_1 \sum_{v_2 \in V_2} \left( 1 - \left( 1 - \frac{1}{k_1} \right)^{\deg(v_2)} \right).$$

However, the function  $f : x \mapsto 1 - \left( 1 - \frac{1}{k_1} \right)^x$  is nondecreasing concave with  $f(0) = 0$ , so  $\frac{f(x)}{x} \geq \frac{f(y)}{y}$  for  $x \leq y$ . In particular, we have that:

$$f(\min(k_1, \deg(v_2))) \geq \frac{\min(k_1, \deg(v_2))}{k_1} f(k_1),$$

and thus:

$$\begin{aligned}
 \mathbb{E}_{\mathcal{P}_1}[e(\mathcal{P}_1, V_2)] &\geq k_1 \sum_{v_2 \in V_2} \left( 1 - \left( 1 - \frac{1}{k_1} \right)^{\min(k_1, \deg(v_2))} \right) \\
 &\geq k_1 \frac{\sum_{v_2 \in V_2} \min(k_1, \deg(v_2))}{k_1} \left( 1 - \left( 1 - \frac{1}{k_1} \right)^{k_1} \right) \tag{5.27} \\
 &\geq \left( 1 - \left( 1 - \frac{1}{k_1} \right)^{k_1} \right) \sum_{v_2 \in V_2} \min(k_1, \deg(v_2)) \\
 &\geq (1 - e^{-1}) \max_{\mathcal{P}_1} e(\mathcal{P}_1, V_2).
 \end{aligned}$$

Let us now consider the general case with  $k_2$  unconstrained. We apply the previous discussion on the graph  $G^{V_1, \mathcal{P}_2}$  for some fixed partition  $\mathcal{P}_2$  of  $V_2$ . Since  $e_{G^{V_1, \mathcal{P}_2}}(\mathcal{P}_1, \mathcal{P}_2) = e(\mathcal{P}_1, \mathcal{P}_2)$ , we have the upper bound:

$$\max_{\mathcal{P}_1} e(\mathcal{P}_1, \mathcal{P}_2) \leq \sum_{i_2=1}^{k_2} \min \left( k_1, \deg_{V_1, \mathcal{P}_2}(\mathcal{P}_2^{i_2}) \right),$$

and the previous algorithm gives us a partition  $\mathcal{P}_1$  of  $V_1$  such that:

$$e(\mathcal{P}_1, \mathcal{P}_2) \geq (1 - e^{-1}) \sum_{i_2=1}^{k_2} \min \left( k_1, \deg_{V_1, \mathcal{P}_2}(\mathcal{P}_2^{i_2}) \right) .$$

Therefore, let us focus on the following optimization problem:

$$\max_{\mathcal{P}_2} \sum_{i_2=1}^{k_2} \min \left( k_1, \deg_{V_1, \mathcal{P}_2}(\mathcal{P}_2^{i_2}) \right) ,$$

We will give a  $(1 - e^{-1})$ -approximation algorithm running in polynomial time for this problem. In all, this will allow us to get in polynomial time a partition pair  $(\mathcal{P}_1, \mathcal{P}_2)$  such that:

$$\begin{aligned} e(\mathcal{P}_1, \mathcal{P}_2) &\geq (1 - e^{-1}) \sum_{i_2=1}^{k_2} \min \left( k_1, \deg_{V_1, \mathcal{P}_2}(\mathcal{P}_2^{i_2}) \right) \\ &\geq (1 - e^{-1})^2 \max_{\mathcal{P}_2} \sum_{i_2=1}^{k_2} \min \left( k_1, \deg_{V_1, \mathcal{P}_2}(\mathcal{P}_2^{i_2}) \right) \\ &\geq (1 - e^{-1})^2 \max_{\mathcal{P}_1, \mathcal{P}_2} e(\mathcal{P}_1, \mathcal{P}_2) . \end{aligned} \quad (5.28)$$

The problem  $\max_{\mathcal{P}_2} \sum_{i_2=1}^{k_2} \min \left( k_1, \deg_{V_1, \mathcal{P}_2}(\mathcal{P}_2^{i_2}) \right)$  is a particular instance of the submodular welfare problem from [Von08]. Note that  $\deg_{V_1, \mathcal{P}_2}(\mathcal{P}_2^{i_2}) = \deg_{V_1, \{\mathcal{P}_2^{i_2}, V_2 - \mathcal{P}_2^{i_2}\}}(\mathcal{P}_2^{i_2})$ , as the degree of  $\mathcal{P}_2^{i_2}$  does not depend on the rest of the partition  $\mathcal{P}_2$ . Then,  $h(S_2) := \min \left( k_1, \deg_{V_1, \{S_2, V_2 - S_2\}}(S_2) \right)$ , for  $S_2 \subseteq V_2$ , is a nondecreasing submodular function, as  $S_2 \mapsto \deg_{V_1, \{S_2, V_2 - S_2\}}(S_2)$  is a nondecreasing submodular function on  $V_2$  and  $\min(k_1, \cdot)$  is nondecreasing concave. Thus, we want to maximize  $\sum_{i_2=1}^{k_2} h(S_{i_2})$  where  $(S_{i_2})_{i_2 \in [k_2]}$  is a partition of items in  $V_2$  among  $k_2$  bidders. It is a particular case of the submodular welfare problem where each nondecreasing submodular utility weight is the same for all bidders and equal to  $h$ . Thus, thanks to [Von08], there exists a polynomial-time  $(1 - e^{-1})$ -approximation of  $\max_{\mathcal{P}_2} \sum_{i_2=1}^{k_2} \min \left( k_1, \deg_{V_1, \mathcal{P}_2}(\mathcal{P}_2^{i_2}) \right)$ .  $\square$

### 5.3.3 Non-Signaling Assisted Capacity Region for Deterministic Channels

Thanks to Theorem 5.8 and Proposition 5.7, there exists a constant-factor approximation algorithm for the broadcast channel coding problem running in polynomial time. We aim to show here that the non-signaling assisted value is linked by a constant factor to the unassisted one. Indeed, the hope is that the non-signaling assisted program is linked to the linear relaxation of the unassisted problem, thus is likely a good approximation since the broadcast channel coding problem can be approximated in polynomial time.

This turns out to be true, and will be proved through the following theorem:

**Theorem 5.10.** *If  $W$  is a deterministic broadcast channel, then for all  $\ell_1 \leq k_1$  and  $\ell_2 \leq k_2$ :*

$$\left( 1 - \frac{k_1^{k_1} e^{-k_1}}{k_1!} \right) \left( 1 - \left( 1 - \frac{1}{\ell_1} \right)^{k_1} \right) \left( 1 - \left( 1 - \frac{1}{\ell_2} \right)^{k_2} \right) S^{\text{NS}}(W, k_1, k_2) \leq S(W, \ell_1, \ell_2) .$$

**Corollary 5.11.** For any deterministic broadcast channel  $W$ ,  $\mathcal{C}^{\text{NS}}(W) = \mathcal{C}(W)$ .

*Proof.* We apply Theorem 5.10 on the deterministic broadcast channel  $W^{\otimes n}$ .

We fix  $k_1 = 2^{nR_1}$ ,  $k_2 = 2^{nR_2}$  and  $\ell_1 = \frac{2^{nR_1}}{n}$ ,  $\ell_2 = \frac{2^{nR_2}}{n}$ . Since  $1 - \left(1 - \frac{1}{\ell}\right)^k \geq 1 - e^{-\frac{k}{\ell}}$ , we get:

$$\left(1 - \frac{k_1^{k_1} e^{-k_1}}{k_1!}\right) (1 - e^{-n})^2 \text{S}^{\text{NS}}(W^{\otimes n}, 2^{nR_1}, 2^{nR_1}) \leq \text{S}\left(W^{\otimes n}, \frac{2^{nR_1}}{n}, \frac{2^{nR_2}}{n}\right).$$

As  $\left(1 - \frac{k_1^{k_1} e^{-k_1}}{k_1!}\right) (1 - e^{-n})^2$  tends to 1 when  $n$  tends to infinity, we get  $\forall \varepsilon > 0, \exists N \in \mathbb{N}, \forall n \geq N$ :

$$(1 - \varepsilon) \text{S}^{\text{NS}}(W^{\otimes n}, 2^{nR_1}, 2^{nR_1}) \leq \text{S}(W^{\otimes n}, 2^{n(R_1 - \frac{\log(n)}{n})}, 2^{n(R_2 - \frac{\log(n)}{n})}).$$

Thus, if  $\lim_{n \rightarrow +\infty} \text{S}^{\text{NS}}(W^{\otimes n}, 2^{nR_1}, 2^{nR_1}) = 1$ , we have that for all  $R'_1 < R_1$  and  $R'_2 < R_2$ :

$$\lim_{n \rightarrow +\infty} \text{S}(W^{\otimes n}, 2^{nR'_1}, 2^{nR'_1}) \geq 1 - \varepsilon.$$

Since this is true for all  $\varepsilon > 0$ , we get in fact that  $\lim_{n \rightarrow +\infty} \text{S}(W^{\otimes n}, 2^{nR'_1}, 2^{nR'_1}) = 1$ . This implies that  $\mathcal{C}^{\text{NS}}(W) \subseteq \mathcal{C}(W)$ , and thus that the capacity regions are equal as the other inclusion is always satisfied.  $\square$

Let us now prove the main result:

*Proof of Theorem 5.10.* The proof will be done in three parts. We will work on the graph  $G_W$  (see Definition 5.3).

1. First, we prove that for any partition  $\mathcal{P}_2$  of  $\mathcal{Y}_2$  in  $\ell_2$  parts:

$$\text{S}(W, \ell_1, \ell_2) \geq \left(1 - \left(1 - \frac{1}{\ell_1}\right)^{k_1}\right) \frac{\sum_{i_2=1}^{\ell_2} \min(k_1, \deg_{\mathcal{Y}_1, \mathcal{P}_2}(\mathcal{P}_2^{i_2}))}{k_1 \ell_2}.$$

2. Then, we show that there exists a partition  $\mathcal{P}_2$  such that:

$$\begin{aligned} & \frac{\sum_{i_2=1}^{\ell_2} \min(k_1, \deg_{\mathcal{Y}_1, \mathcal{P}_2}(\mathcal{P}_2^{i_2}))}{k_1 \ell_2} \\ & \geq \left(1 - \frac{k_1^{k_1} e^{-k_1}}{k_1!}\right) \left(1 - \left(1 - \frac{1}{\ell_2}\right)^{k_2}\right) \frac{\min(k_1 k_2, \sum_{y_1} \min(k_2, \deg(y_1)))}{k_1 k_2}. \end{aligned} \quad (5.29)$$

3. Finally, we prove that:

$$\frac{\min(k_1 k_2, \sum_{y_1} \min(k_2, \deg(y_1)))}{k_1 k_2} \geq \text{S}^{\text{NS}}(W, k_1, k_2).$$

By combining these three inequalities, we get precisely the claimed result.

1. This part shares a lot of similarities with the proof of Theorem 5.8, which we will adapt to this particular situation. Let us show that if we take a partition  $\mathcal{P}_1$  of  $\mathcal{Y}_1$  of size  $\ell_1$  uniformly at random, we get, for some fixed  $\mathcal{P}_2$  of size  $\ell_2$ :

$$\mathbb{E}_{\mathcal{P}_1}[e_{GW}(\mathcal{P}_1, \mathcal{P}_2)] \geq \frac{\ell_1}{k_1} \left(1 - \left(1 - \frac{1}{\ell_1}\right)^{k_1}\right) \sum_{i_2=1}^{\ell_2} \min(k_1, \deg_{\mathcal{Y}_1, \mathcal{P}_2}(\mathcal{P}_2^{i_2})).$$

Since  $\ell_1 \ell_2 S(W, \ell_1, \ell_2) = \underset{\mathcal{P}_1 \text{ in } \ell_1 \text{ parts}, \mathcal{P}_2 \text{ in } \ell_2 \text{ parts}}{\text{maximize}} e_{GW}(\mathcal{P}_1, \mathcal{P}_2)$  by Proposition 5.7, this will imply that:

$$\begin{aligned} S(W, \ell_1, \ell_2) &\geq \frac{1}{\ell_1 \ell_2} \mathbb{E}_{\mathcal{P}_1}[e_{GW}(\mathcal{P}_1, \mathcal{P}_2)] \\ &\geq \left(1 - \left(1 - \frac{1}{\ell_1}\right)^{k_1}\right) \frac{\sum_{i_2=1}^{\ell_2} \min(k_1, \deg_{\mathcal{Y}_1, \mathcal{P}_2}(\mathcal{P}_2^{i_2}))}{k_1 \ell_2}. \end{aligned} \quad (5.30)$$

We have that  $e_{GW}(\mathcal{P}_1, \mathcal{P}_2) = \sum_{i_2=1}^{\ell_2} \deg_{\mathcal{P}_1, \mathcal{P}_2}(\mathcal{P}_2^{i_2})$ , so by linearity of expectation, we have that  $\mathbb{E}_{\mathcal{P}_1}[e_{GW}(\mathcal{P}_1, \mathcal{P}_2)] = \sum_{i_2=1}^{\ell_2} \mathbb{E}_{\mathcal{P}_1}[\deg_{\mathcal{P}_1, \mathcal{P}_2}(\mathcal{P}_2^{i_2})]$ , so we will focus on the contribution of one particular  $\mathcal{P}_2^{i_2}$ .

Then, we have that  $\deg_{\mathcal{P}_1, \mathcal{P}_2}(\mathcal{P}_2^{i_2}) = |\{i_1 \in [\ell_1] : N_{\mathcal{Y}_1, \mathcal{P}_2}(\mathcal{P}_2^{i_2}) \cap \mathcal{P}_1^{i_1} \neq \emptyset\}|$ . Recall that  $\mathbb{P}(v_1 \in \mathcal{P}_1^{i_1}) = \frac{1}{\ell_1}$  for any  $v_1$  since the partition is taken uniformly at random. Thus:

$$\begin{aligned} \mathbb{E}_{\mathcal{P}_1}[\deg_{\mathcal{P}_1, \mathcal{P}_2}(\mathcal{P}_2^{i_2})] &= \mathbb{E}_{\mathcal{P}_1} \left[ |\{i_1 \in [\ell_1] : N_{\mathcal{Y}_1, \mathcal{P}_2}(\mathcal{P}_2^{i_2}) \cap \mathcal{P}_1^{i_1} \neq \emptyset\}| \right] \\ &= \mathbb{E}_{\mathcal{P}_1} \left[ \sum_{i_1=1}^{\ell_1} \mathbb{1}_{N_{\mathcal{Y}_1, \mathcal{P}_2}(\mathcal{P}_2^{i_2}) \cap \mathcal{P}_1^{i_1} \neq \emptyset} \right] = \sum_{i_1=1}^{\ell_1} \mathbb{E}_{\mathcal{P}_1} \left[ \mathbb{1}_{N_{\mathcal{Y}_1, \mathcal{P}_2}(\mathcal{P}_2^{i_2}) \cap \mathcal{P}_1^{i_1} \neq \emptyset} \right] \\ &= \sum_{i_1=1}^{\ell_1} \mathbb{P}(N_{\mathcal{Y}_1, \mathcal{P}_2}(\mathcal{P}_2^{i_2}) \cap \mathcal{P}_1^{i_1} \neq \emptyset) = \sum_{i_1=1}^{\ell_1} \left(1 - \mathbb{P}(N_{\mathcal{Y}_1, \mathcal{P}_2}(\mathcal{P}_2^{i_2}) \cap \mathcal{P}_1^{i_1} = \emptyset)\right) \\ &= \sum_{i_1=1}^{\ell_1} \left(1 - \prod_{v_1 \in N(\mathcal{P}_2^{i_2})} \mathbb{P}(v_1 \notin \mathcal{P}_1^{i_1})\right) = \ell_1 \left(1 - \left(1 - \frac{1}{\ell_1}\right)^{\deg_{\mathcal{Y}_1, \mathcal{P}_2}(\mathcal{P}_2^{i_2})}\right). \end{aligned} \quad (5.31)$$

So, in all we have that:

$$\begin{aligned} \mathbb{E}_{\mathcal{P}_1}[e_{GW}(\mathcal{P}_1, \mathcal{P}_2)] &= \sum_{i_2=1}^{\ell_2} \mathbb{E}_{\mathcal{P}_1}[\deg_{\mathcal{P}_1, \mathcal{P}_2}(\mathcal{P}_2^{i_2})] \\ &= \ell_1 \sum_{i_2=1}^{\ell_2} \left(1 - \left(1 - \frac{1}{\ell_1}\right)^{\deg_{\mathcal{Y}_1, \mathcal{P}_2}(\mathcal{P}_2^{i_2})}\right). \end{aligned} \quad (5.32)$$

However the function  $f : x \mapsto 1 - \left(1 - \frac{1}{\ell_1}\right)^x$  is nondecreasing concave with  $f(0) = 0$ , so  $\frac{f(x)}{x} \geq \frac{f(y)}{y}$  for  $x \leq y$ . In particular, we have that:

$$f(\min(k_1, \deg_{\mathcal{Y}_1, \mathcal{P}_2}(\mathcal{P}_2^{i_2}))) \geq \frac{\min(k_1, \deg_{\mathcal{Y}_1, \mathcal{P}_2}(\mathcal{P}_2^{i_2}))}{k_1} f(k_1),$$



and thus:

$$\begin{aligned}
 \mathbb{E}_{\mathcal{P}_1}[e_{G_W}(\mathcal{P}_1, \mathcal{P}_2)] &\geq \ell_1 \sum_{i_2=1}^{\ell_2} \left( 1 - \left( 1 - \frac{1}{\ell_1} \right)^{\min(k_1, \deg_{\mathcal{Y}_1, \mathcal{P}_2}(\mathcal{P}_2^{i_2}))} \right) \\
 &\geq \ell_1 \frac{\sum_{i_2=1}^{\ell_2} \min(k_1, \deg_{\mathcal{Y}_1, \mathcal{P}_2}(\mathcal{P}_2^{i_2}))}{k_1} \left( 1 - \left( 1 - \frac{1}{\ell_1} \right)^{k_1} \right) \\
 &= \frac{\ell_1}{k_1} \left( 1 - \left( 1 - \frac{1}{\ell_1} \right)^{k_1} \right) \sum_{i_2=1}^{\ell_2} \min(k_1, \deg_{\mathcal{Y}_1, \mathcal{P}_2}(\mathcal{P}_2^{i_2})), \tag{5.33}
 \end{aligned}$$

which concludes the first part of the proof.

2. Let us take  $\mathcal{P}_2$  a partition of  $\mathcal{Y}_2$  of size  $\ell_2$  uniformly at random, and let us prove that:

$$\mathbb{E} \left[ \sum_{i_2=1}^{\ell_2} \min(k_1, \deg_{\mathcal{Y}_1, \mathcal{P}_2}(\mathcal{P}_2^{i_2})) \right]$$

is greater than or equal to:

$$\frac{\ell_2}{k_2} \left( 1 - \frac{k_1^{k_1} e^{-k_1}}{k_1!} \right) \left( 1 - \left( 1 - \frac{1}{\ell_2} \right)^{k_2} \right) \min \left( k_1 k_2, \sum_{y_1} \min(k_2, \deg(y_1)) \right).$$

First,  $\sum_{i_2=1}^{\ell_2} \min(k_1, \deg_{\mathcal{Y}_1, \mathcal{P}_2}(\mathcal{P}_2^{i_2})) = \sum_{i_2=1}^{\ell_2} \varphi(\deg_{\mathcal{Y}_1, \mathcal{P}_2}(\mathcal{P}_2^{i_2}))$  with  $\varphi(j) := \min(k_1, j)$  which is a concave function. Recall the definition of the Poisson concavity ratio 3.1  $\alpha_\varphi = \inf_{x \in \mathbb{R}^+} \frac{\mathbb{E}[\varphi(\text{Poi}(x))]}{\varphi(x)}$  which is equal to  $1 - \frac{k_1^{k_1} e^{-k_1}}{k_1!}$  for that particular function. Let us find the law of  $\deg_{\mathcal{Y}_1, \mathcal{P}_2}(\mathcal{P}_2^{i_2})$ :

$$\begin{aligned}
 \deg_{\mathcal{Y}_1, \mathcal{P}_2}(\mathcal{P}_2^{i_2}) &= \sum_{y_1} \mathbb{1}_{N(y_1) \cap \mathcal{P}_2^{i_2} \neq \emptyset} = \sum_{y_1} \left( 1 - \mathbb{1}_{N(y_1) \cap \mathcal{P}_2^{i_2} = \emptyset} \right) \\
 &= \sum_{y_1} \left( 1 - \mathbb{1}_{\forall y_2 \in N(y_1), y_2 \notin \mathcal{P}_2^{i_2}} \right) = \sum_{y_1} \text{Ber} \left( 1 - \left( 1 - \frac{1}{\ell_2} \right)^{\deg(y_1)} \right) \tag{5.34}
 \end{aligned}$$

Thus:

$$\begin{aligned}
 \mathbb{E} \left[ \varphi(\deg_{\mathcal{Y}_1, \mathcal{P}_2}(\mathcal{P}_2^{i_2})) \right] &= \mathbb{E} \left[ \varphi \left( \sum_{y_1} \text{Ber} \left( 1 - \left( 1 - \frac{1}{\ell_2} \right)^{\deg(y_1)} \right) \right) \right] \\
 &\geq \mathbb{E} \left[ \varphi \left( \text{Poi} \left( \sum_{y_1} \left( 1 - \left( 1 - \frac{1}{\ell_2} \right)^{\deg(y_1)} \right) \right) \right) \right] \text{ by Proposition 2.2} \tag{5.35} \\
 &\geq \alpha_\varphi \varphi \left( \sum_{y_1} \left( 1 - \left( 1 - \frac{1}{\ell_2} \right)^{\deg(y_1)} \right) \right) \text{ by definition of } \alpha_\varphi.
 \end{aligned}$$

But:

$$\begin{aligned} \sum_{y_1} \left( 1 - \left( 1 - \frac{1}{\ell_2} \right)^{\deg(y_1)} \right) &\geq \sum_{y_1} \left( 1 - \left( 1 - \frac{1}{\ell_2} \right)^{\min(k_2, \deg(y_1))} \right) \\ &\geq \left( 1 - \left( 1 - \frac{1}{\ell_2} \right)^{k_2} \right) \frac{1}{k_2} \sum_{y_1} \min(k_2, \deg(y_1)) , \end{aligned} \quad (5.36)$$

as before. Since  $\varphi$  is concave and  $\varphi(0) = 0$ , we have in particular that for all  $0 \leq c \leq 1$  and  $x \in \mathbb{R}$ ,  $\varphi(cx) \geq c\varphi(x)$ . We know also that  $\varphi$  is nondecreasing. This implies that:

$$\begin{aligned} &\varphi \left( \sum_{y_1} \left( 1 - \left( 1 - \frac{1}{\ell_2} \right)^{\deg(y_1)} \right) \right) \\ &\geq \varphi \left( \left( 1 - \left( 1 - \frac{1}{\ell_2} \right)^{k_2} \right) \frac{1}{k_2} \sum_{y_1} \min(k_2, \deg(y_1)) \right) \\ &\geq \left( 1 - \left( 1 - \frac{1}{\ell_2} \right)^{k_2} \right) \varphi \left( \frac{1}{k_2} \sum_{y_1} \min(k_2, \deg(y_1)) \right) , \end{aligned} \quad (5.37)$$

as  $0 \leq 1 - \left( 1 - \frac{1}{\ell_2} \right)^{k_2} \leq 1$ . Thus  $\mathbb{E} \left[ \varphi(\deg_{\mathcal{Y}_1, \mathcal{P}_2}(\mathcal{P}_2^{i_2})) \right]$  is larger than or equal to:

$$\begin{aligned} &\alpha_\varphi \left( 1 - \left( 1 - \frac{1}{\ell_2} \right)^{k_2} \right) \min \left( k_1, \frac{1}{k_2} \sum_{y_1} \min(k_2, \deg(y_1)) \right) \\ &= \frac{1}{k_2} \left( 1 - \frac{k_1^{k_1} e^{-k_1}}{k_1!} \right) \left( 1 - \left( 1 - \frac{1}{\ell_2} \right)^{k_2} \right) \min \left( k_1 k_2, \sum_{y_1} \min(k_2, \deg(y_1)) \right) \end{aligned} \quad (5.38)$$

since  $\alpha_\varphi = 1 - \frac{k_1^{k_1} e^{-k_1}}{k_1!}$ .

Finally,  $\mathbb{E} \left[ \sum_{i_2=1}^{\ell_2} \min(k_1, \deg_{\mathcal{Y}_1, \mathcal{P}_2}(\mathcal{P}_2^{i_2})) \right] = \sum_{i_2=1}^{\ell_2} \mathbb{E} \left[ \varphi(\deg_{\mathcal{Y}_1, \mathcal{P}_2}(\mathcal{P}_2^{i_2})) \right]$ , so we get that:

$$\mathbb{E} \left[ \sum_{i_2=1}^{\ell_2} \min(k_1, \deg_{\mathcal{Y}_1, \mathcal{P}_2}(\mathcal{P}_2^{i_2})) \right]$$

is larger than or equal to:

$$\frac{\ell_2}{k_2} \left( 1 - \frac{k_1^{k_1} e^{-k_1}}{k_1!} \right) \left( 1 - \left( 1 - \frac{1}{\ell_2} \right)^{k_2} \right) \min \left( k_1 k_2, \sum_{y_1} \min(k_2, \deg(y_1)) \right) .$$

Thus, in particular, there exists some partition  $\mathcal{P}_2$  that satisfies the same inequality, which concludes the second part of the proof.

3. Let us consider an optimal solution  $r_{x, y_1, y_2}, p_x, r_{x, y_1}^1, r_{x, y_2}^2$  of the program computing  $\text{S}^{\text{NS}}(W, k_1, k_2)$ , so that  $\text{S}^{\text{NS}}(W, k_1, k_2) = \frac{1}{k_1 k_2} \sum_x r_{x, W_1(x), W_2(x)}$ .

a) It comes directly from  $r_{x, y_1, y_2} \leq p_x$  that:

$$\sum_x r_{x, W_1(x), W_2(x)} \leq \sum_x p_x = k_1 k_2 .$$

b)  $\sum_x r_{x,W_1(x),W_2(x)} = \sum_{y_1} \sum_{x:W_1(x)=y_1} r_{x,y_1,W_2(x)}$  and we have that:

i.  $\sum_{x:W_1(x)=y_1} r_{x,y_1,W_2(x)} \leq \sum_{x:W_1(x)=y_1} 1 = \deg(y_1)$ ,

ii.  $\sum_{x:W_1(x)=y_1} r_{x,y_1,W_2(x)} \leq \sum_{x:W_1(x)=y_1} r_{x,y_1}^1 \leq \sum_x r_{x,y_1}^1 = k_2$ ,

so  $\sum_{x:W_1(x)=y_1} r_{x,y_1,W_2(x)} \leq \min(k_2, \deg(y_1))$ , and thus:

$$\sum_x r_{x,W_1(x),W_2(x)} \leq \sum_{y_1} \min(k_2, \deg(y_1)).$$

In all, we get that:

$$S^{\text{NS}}(W, k_1, k_2) = \frac{1}{k_1 k_2} \sum_x r_{x,W_1(x),W_2(x)} \leq \frac{\min(k_1 k_2, \sum_{y_1} \min(k_2, \deg(y_1)))}{k_1 k_2},$$

which concludes the third and last part of the proof. □

## 5.4 Hardness of Approximation for Broadcast Channel Coding

Since broadcast channels are more general than point-to-point channels (by defining  $W_1(y_1|x) := \hat{W}(y_1|x)$  for  $\hat{W}$  a point-to-point channel and taking  $W_2(y_2|x) = \frac{1}{|\mathcal{Y}_2|}$  a completely trivial channel), computing a single value  $S(W, k_1, k_2)$  is NP-hard, and it is even NP-hard to approximate within a better factor than  $1 - e^{-1}$ , as a consequence of the hardness result for point-to-point channels from [BF18].

The goal of this section is to give some evidence for the hardness of approximation of the general broadcast channel coding problem, specifically that it cannot be approximated in polynomial time within a  $\Omega(1)$  factor. It will be a good insight that non-signaling assistance will enlarge the capacity region of the channel as discussed in the introduction.

Formally, one would want to show that it is NP-hard to approximate this problem within a  $\Omega(1)$  factor in polynomial time. As a first step towards this goal, we will prove a  $\Omega\left(\frac{1}{\sqrt{m}}\right)$ -approximation hardness in the value query model.

First, let us introduce formally the problem:

**Definition 5.5** (BCC). Given a channel  $W$  and integers  $k_1, k_2$ , the broadcast channel coding problem, which we call BCC, entails maximizing:

$$S(W, k_1, k_2, e, d_1, d_2) := \frac{1}{k_1 k_2} \sum_{i_1, i_2, y_1, y_2} W(y_1 y_2 | e(i_1, i_2)) \mathbb{1}_{d_1(y_1)=i_1, d_2(y_2)=i_2},$$

over all functions  $e : [k_1] \times [k_2] \rightarrow \mathcal{X}$ ,  $d_1 : \mathcal{Y}_1 \rightarrow [k_1]$  and  $d_2 : \mathcal{Y}_2 \rightarrow [k_2]$ .

As in the deterministic case, we restrict ourselves to deterministic encoders and decoders, which does not change the value nor the hardness of the problem. Also, it can be equivalently stated in terms of partitions corresponding to  $d_1, d_2$  as:

**Proposition 5.12** (Equivalent formulation of BCC). *Given a channel  $W$  and integers  $k_1$  and  $k_2$ , the broadcast channel coding problem, which we call BCC, entails maximizing:*

$$\frac{1}{k_1 k_2} \sum_{i_1, i_2} \max_x \sum_{y_1 \in \mathcal{P}_1^{i_1}, y_2 \in \mathcal{P}_1^{i_2}} W(y_1 y_2 | x),$$

over all partitions  $\mathcal{P}_1$  of  $\mathcal{Y}_1$  in  $k_1$  parts and  $\mathcal{P}_2$  of  $\mathcal{Y}_2$  in  $k_2$  parts.

### 5.4.1 Social Welfare Reformulation

The social welfare maximization problem is defined as follows: given a set  $M$  of  $m$  items as well as  $k$  bidders with their associated utilities  $(v_i : 2^M \rightarrow \mathbb{R}_+)_{i \in [k]}$ , the goal is to partition  $M$  between the bidders to maximize the sum of their utilities. Formally, we want to compute:

$$\text{maximize}_{\mathcal{P} \text{ partition in } k \text{ parts of } M} \sum_{i=1}^k v_i(\mathcal{P}^i).$$

Let us show that the subproblem of BCC restricted to  $k_2 = |\mathcal{Y}_2|$  can be reformulated as a particular instance of the social welfare maximization problem. In that case, it is easy to see that  $\mathcal{P}_2 = (\{y_2\})_{y_2 \in \mathcal{Y}_2}$  is always an optimal solution. Indeed, for any partition  $\mathcal{P}_2$ , we have:

$$\begin{aligned} \frac{1}{k_1 |\mathcal{Y}_2|} \sum_{i_1, i_2} \max_x \sum_{y_1 \in \mathcal{P}_1^{i_1}, y_2 \in \mathcal{P}_2^{i_2}} W(y_1 y_2 | x) &\leq \frac{1}{k_1 |\mathcal{Y}_2|} \sum_{i_1, i_2} \sum_{y_2 \in \mathcal{P}_2^{i_2}} \max_x \sum_{y_1 \in \mathcal{P}_1^{i_1}} W(y_1 y_2 | x) \\ &= \frac{1}{k_1 |\mathcal{Y}_2|} \sum_{i_1} \sum_{y_2 \in \mathcal{Y}_2} \max_x \sum_{y_1 \in \mathcal{P}_1^{i_1}} W(y_1 y_2 | x). \end{aligned} \tag{5.39}$$

Therefore, the objective function becomes:

$$S^1(W, k_1, \mathcal{P}_1) := \frac{1}{k_1} \sum_{i_1=1}^{k_1} f_W^1(\mathcal{P}_1^{i_1}) \text{ with } f_W^1(S_1) := \frac{1}{|\mathcal{Y}_2|} \sum_{y_2} \max_x \sum_{y_1 \in S_1} W(y_1 y_2 | x).$$

Hence, up to a multiplicative factor  $k_1$ , maximizing  $S^1(W, k_1, \mathcal{P}_1)$  over all partitions  $\mathcal{P}_1$  of size  $k_1$  is a particular case of the social welfare maximization problem with a common utility  $f_W^1$  for all  $k_1$  bidders.

### 5.4.2 Value Query Hardness

Let us first introduce the value query model. As described in [DS06, MSV08], a value query to a utility  $v$  asks for the value of some input set  $S \subseteq M$ , and gets as response  $v(S) \in \mathbb{R}_+$ . In the value query model, we aim at solving the social welfare maximization problem accessing the data only through value queries to  $(v_i)_{i \in [k]}$ .

This is more restricted than using any algorithm, but in such a model, it is possible to show unconditional lower bounds on the number of queries needed to solve a given problem within an approximation rate. In the case of the social welfare maximization problem with XOS utility functions, the approximation rate achievable in polynomial time has

been proved in [DS06, MSV08] to be of the order of  $\Theta\left(\frac{1}{\sqrt{m}}\right)$ . Specifically, in [DS06], a  $\Omega\left(\frac{1}{m^{\frac{1}{2}}}\right)$ -approximation in polynomial time was given, and in [MSV08], it has been shown that any  $\Omega\left(\frac{1}{m^{\frac{1}{2}-\varepsilon}}\right)$ -approximation for  $\varepsilon > 0$  requires an exponential number of value queries. We will adapt their proof in the particular case of one common XOS utility function of the form  $f_W^1$  for some broadcast channel  $W$ . But first, let us introduce the definition of XOS functions and prove that  $f_W^1$  is one of those.

**Definition 5.6.** A linear valuation function (also known as additive) is a set function  $a : 2^M \rightarrow \mathbb{R}_+$  that assigns a nonnegative value to every singleton  $\{j\}$  for  $j \in M$ , and for all  $S \subseteq M$  it holds that  $a(S) = \sum_{j \in S} a(\{j\})$ .

A fractionally sub-additive function (XOS) is a set function  $f : 2^M \rightarrow \mathbb{R}_+$ , for which there is a finite set of linear valuation functions  $A = \{a_1, \dots, a_\ell\}$  such that  $f(S) = \max_{i \in [\ell]} a_i(S)$  for every  $S \subseteq M$ .

*Remark.* Note that the size of  $A$  is not bounded in the definition.

**Proposition 5.13.**  $f_W^1$  is XOS.

*Proof.*

$$\begin{aligned} f_W^1(S) &= \frac{1}{|\mathcal{Y}_2|} \sum_{y_2} \max_x \sum_{y_1 \in S_1} W(y_1 y_2 | x) = \max_{\lambda: \mathcal{Y}_2 \rightarrow \mathcal{X}} a_\lambda(S), \text{ where} \\ a_\lambda(S) &= \frac{1}{|\mathcal{Y}_2|} \sum_{y_2} \sum_{y_1 \in S} W(y_1 y_2 | \lambda(y_2)) = \sum_{y_1 \in S} \left[ \frac{1}{|\mathcal{Y}_2|} \sum_{y_2} W(y_1 y_2 | m(y_2)) \right] \\ &= \sum_{y_1 \in S} a_\lambda(\{y_1\}) \text{ with } a_\lambda(\{y_1\}) = \frac{1}{|\mathcal{Y}_2|} \sum_{y_2} W(y_1 y_2 | \lambda(y_2)) \in \mathbb{R}_+ \end{aligned} \quad (5.40)$$

So  $f_W^1$  is the maximum of the set of  $a_\lambda$  for  $\lambda \in \mathcal{X}^{\mathcal{Y}_2}$ , which are linear valuation functions, thus  $f_W^1$  is XOS.  $\square$

Let us now state the value query hardness of approximation of the broadcast channel problem:

**Theorem 5.14.** *In the value query model, for any fixed  $\varepsilon > 0$ , a  $\Omega\left(\frac{1}{m^{\frac{1}{2}-\varepsilon}}\right)$ -approximation algorithm for the broadcast channel coding problem on  $W, k_1, k_2$ , restricted to the case of  $|\mathcal{Y}_2| = k_2$  and  $m = |\mathcal{Y}_1| = k_1^2$ , requires exponentially many value queries to  $f_W^1$ .*

*Remark.* As our problem is a particular instance of the social welfare maximization problem with XOS functions, the polynomial-time  $\Omega\left(\frac{1}{m^{\frac{1}{2}}}\right)$ -approximation from [DS06] works also here.

*Proof.* The proof is inspired by Theorem 3.1 of [MSV08]. We will show using probabilistic arguments that any  $\Omega\left(\frac{1}{m^{\frac{1}{2}-\varepsilon}}\right)$ -approximation algorithm requires an exponential number of value queries. Let us fix a small constant  $\delta > 0$ . We choose  $k_1 \in \mathbb{N}$  as the number of

messages (the bidders) and the output space  $\mathcal{Y}_1 := [m]$  with  $m := k_1^2$  (the items). Then, we choose uniformly at random an equi-partition of  $\mathcal{Y}_1$  in  $k_1$  parts of size  $k_1$ , which we name  $T_1, \dots, T_{k_1}$ .

Let us define now  $\mathcal{Y}_2 := [m + k_1 + 1]$ . We take  $\mathcal{X} := \mathcal{Y}_2 = [m + 1 + k_1]$  as well. We can now define our broadcast channel  $W$ , with some positive constant  $C$  to be fixed later to guarantee that  $W$  is a conditional probability distribution. Let us define its value for  $y_2 = 1$ :

$$W(y_1 1|x) := C \times \begin{cases} m^{2\delta} \mathbb{1}_{y_1=x} & \text{when } 1 \leq x \leq m, \\ \frac{1}{m^{\frac{1}{2}-\delta}} & \text{when } x = m + 1, \\ \mathbb{1}_{y_1 \in T_j} & \text{when } 1 \leq j := x - (m + 1) \leq k_1. \end{cases}$$

Then, we define other  $y_2$  inputs as translations of  $W(y_1 1|x)$ . Specifically, we define:

$$W(y_1 y_2|x) := W(y_1 1|t_{y_2-1}(x)) \text{ with } t_s(x) := 1 + [(x - 1 + s) \bmod (m + k_1 + 1)].$$

All coefficients are nonnegative. So  $W$  will be a channel if for all  $x$ ,  $\sum_{y_1, y_2} W(y_1 y_2|x) = 1$ . However, one has, for some fixed  $x_0$ :

$$\begin{aligned} \sum_{y_1, y_2} W(y_1 y_2|x_0) &= \sum_{y_1} \sum_{y_2} W(y_1 y_2|x_0) = \sum_{y_1} \sum_{y_2} W(y_1 1|t_{y_2-1}(x_0)) = \sum_{y_1} \sum_x W(y_1 1|x) \\ &= C \sum_{y_1} \left[ \sum_{1 \leq i \leq m} m^{2\delta} \mathbb{1}_{y_1=i} + \frac{1}{m^{\frac{1}{2}-\delta}} + \sum_{1 \leq j \leq k_1} \mathbb{1}_{y_1 \in T_j} \right] \\ &= C \left[ \sum_{1 \leq i \leq m} m^{2\delta} + m \times \frac{1}{m^{\frac{1}{2}-\delta}} + \sum_{1 \leq j \leq k_1} k_1 \right] \\ &= 1, \end{aligned} \tag{5.41}$$

by choosing  $C = \frac{1}{m^{1+2\delta} + m^{\frac{1}{2}+\delta} + m}$ , which does not depend on  $x_0$ . Thus, we have defined a correct instance of our problem. Note that on this instance, we have:

$$\begin{aligned} f_W^1(S) &= \frac{1}{|\mathcal{Y}_2|} \sum_{y_2} \max_x \sum_{y_1 \in S} W(y_1 y_2|x) = \sum_{y_2} \max_x \sum_{y_1 \in S} W(y_1 1|t_{y_2-1}(x)) \\ &= \frac{m + k_1 + 1}{|\mathcal{Y}_2|} \max_x \sum_{y_1 \in S} W(y_1 1|x) \text{ since } t_{y_2-1} \text{ bijection} \\ &= \frac{C(m + k_1 + 1)}{|\mathcal{Y}_2|} \times \max \begin{cases} m^{2\delta} |\{i\} \cap S| & \text{for } 1 \leq i \leq m \\ \frac{1}{m^{\frac{1}{2}-\delta}} |S| & \\ |T_j \cap S| & \text{for } 1 \leq j \leq k_1 \end{cases} \end{aligned} \tag{5.42}$$

Let us also consider an alternate broadcast channel  $W'$ , with the only difference that  $\mathbb{1}_{y_1 \in T_j}$  is replaced by  $\frac{1}{m^{\frac{1}{2}}}$ , for  $j \in [k_1]$ . For that channel, the constant  $C$  remains the same (since

$\sum_j \sum_{y_1} \mathbb{1}_{y_1 \in T_j} = k_1 \times k_1 = k_1 \times m \times \frac{1}{k_1} = \sum_j \sum_{y_1} \frac{1}{m^{\frac{1}{2}}}$ , so we get that:

$$\begin{aligned} f_{W'}^1(S) &= \frac{C(m+k_1+1)}{|\mathcal{Y}_2|} \times \max \begin{cases} m^{2\delta} |\{i\} \cap S| & \text{for } 1 \leq i \leq m \\ \frac{1}{m^{\frac{1}{2}-\delta}} |S| & \\ \frac{1}{m^{\frac{1}{2}}} |S| & \text{for } 1 \leq j \leq k_1 \end{cases} \\ &= \frac{C(m+k_1+1)}{|\mathcal{Y}_2|} \times \max \begin{cases} m^{2\delta} |\{i\} \cap S| & \text{for } 1 \leq i \leq m \\ \frac{1}{m^{\frac{1}{2}-\delta}} |S| & \end{cases} \end{aligned} \quad (5.43)$$

since  $\frac{1}{m^{\frac{1}{2}}} |S| \leq \frac{1}{m^{\frac{1}{2}-\delta}} |S|$ . Let us consider normalized versions  $v(S) := \frac{|\mathcal{Y}_2|}{C(m+k_1+1)} f_W^1(S)$  and  $v'(S) := \frac{|\mathcal{Y}_2|}{C(m+k_1+1)} f_{W'}^1(S)$ , so distinguishing between  $v$  and  $v'$  is the same as distinguishing between  $f_W^1$  and  $f_{W'}^1$ . We will prove that it takes an exponential number of value queries to distinguish between  $v$  and  $v'$ . On the one hand, one can easily show that the maximum value of the social welfare problem with  $v'$  is  $(k_1 - 1)m^{2\delta} + \frac{1}{m^{\frac{1}{2}-\delta}}(m - (k_1 - 1)) = O(m^{\frac{1}{2}+2\delta})$ , obtained taking  $(k_1 - 1)$  singletons as the first components of the partition (the bidders), giving the rest of  $\mathcal{Y}_1$  (the items) to the last. On the other hand, the maximum value of the social welfare problem with  $v$  is  $k_1 \times k_1 = m$ , obtained with the partition  $T_1, \dots, T_{k_1}$ . The fact that it requires an exponential number of value queries to distinguish between the two situations will imply that one cannot get an approximation rate better than  $\Omega\left(\frac{1}{m^{\frac{1}{2}-2\delta}}\right)$  in less than an exponential number of value queries.

We will now prove that distinguishing between  $v$  and  $v'$  requires an exponential number of value queries. Note first that  $v(\emptyset) = v'(\emptyset) = 0$ , so we do not need to consider empty sets.

Let us fix some non-empty set  $S \subseteq [m]$ . Let us define the random boolean variables  $X_j^i := \mathbb{1}_{i \in T_j}$  for  $j \in [k_1]$  and  $i \in [m]$ . By construction of the random equi-partition  $T_1, \dots, T_{k_1}$ ,  $(X_j^i)_{i \in [m]}$  is a permutation distribution (see Definition 2.3) of  $(0, \dots, 0, 1, \dots, 1)$  with  $m - k_1$  zeros and  $k_1$  ones, each  $X_j^i$  following a Bernoulli law of parameter  $p := \frac{1}{k_1}$ . Thus it is negatively associated by Proposition 2.8, and the sub-family  $(X_j^i)_{i \in S}$  is negatively associated as well by Proposition 2.4. Note in particular that  $|T_j \cap S| = \sum_{i \in S} X_j^i$  is a sum of negatively associated Bernoulli variables of the same parameter  $p$ , so the version of the Chernoff-Hoeffding bound from Proposition 2.10 holds.

Let us first assume that  $S$  is of size  $0 < |S| \leq m^{\frac{1}{2}+\delta}$ . Then, we have that  $\frac{1}{m^{\frac{1}{2}-\delta}} |S| \leq m^{2\delta}$ , so we get that  $v'(S) = m^{2\delta}$ . On the other hand, we have that:

$$v(S) = \max \begin{cases} m^{2\delta} \\ |T_j \cap S| \text{ for } 1 \leq j \leq k_1 \end{cases} \quad (5.44)$$

Thus,  $v(S)$  is different from  $v'(S)$  if and only if  $\exists j \in [k_1], |T_j \cap S| > m^{2\delta}$ . But, we have:

$$\begin{aligned}
 \mathbb{P}\left(\exists j \in [k_1], |T_j \cap S| > m^{2\delta}\right) &\leq \sum_{j \in [k_1]} \mathbb{P}\left(|T_j \cap S| > m^{2\delta}\right) \text{ by union bound} \\
 &= \sum_{j \in [k_1]} \mathbb{P}\left(\sum_{i \in S} X_j^i > m^{2\delta}\right) = \sum_{j \in [k_1]} \mathbb{P}\left(\frac{1}{|S|} \sum_{i \in S} X_j^i > \left(1 + \frac{m^{2\delta} - 1}{p}\right) p\right) \\
 &\leq \sum_{j \in [k_1]} \mathbb{P}\left(\frac{1}{|S|} \sum_{i \in S} X_j^i > \left(1 + \frac{m^{2\delta}}{p}\right) p\right) \\
 &\leq \sum_{j \in [k_1]} \exp\left(-\frac{p|S|}{4} \left(\frac{m^{2\delta}}{p|S|}\right)^2\right) \text{ by Proposition 2.10} \\
 &= \sum_{j \in [k_1]} \exp\left(-\frac{1}{4p|S|} m^{4\delta}\right) \leq \sum_{j \in [k_1]} \exp\left(-\frac{m^{-\delta}}{4} m^{4\delta}\right) \text{ since } \frac{1}{p|S|} = \frac{k_1}{|S|} \geq m^{-\delta} \\
 &= m^{\frac{1}{2}} e^{-\frac{m^{3\delta}}{4}}.
 \end{aligned} \tag{5.45}$$

Thus, this event occurs with exponentially small probability (on the choice of the partition  $T_1, \dots, T_{k_1}$ ).

Let us now study the case of  $S$  of size  $|S| > m^{\frac{1}{2}+\delta}$ . Then, we have that  $\frac{1}{m^{\frac{1}{2}-\delta}}|S| > m^{2\delta}$ , so we get that  $v'(S) = \frac{1}{m^{\frac{1}{2}-\delta}}|S|$ . On the other hand, we have that:

$$v(S) = \max \left\{ \begin{array}{l} \frac{1}{m^{\frac{1}{2}-\delta}}|S| \\ |T_j \cap S| \text{ for } 1 \leq j \leq k_1 \end{array} \right. \tag{5.46}$$

Thus,  $v(S)$  is different from  $v'(S)$  if and only if  $\exists j \in [k_1], |T_j \cap S| > \frac{1}{m^{\frac{1}{2}-\delta}}|S|$ . But, we



have:

$$\begin{aligned}
 \mathbb{P}\left(\exists j \in [k_1], |T_j \cap S| > \frac{1}{m^{\frac{1}{2}-\delta}}|S|\right) &\leq \sum_{j \in [k_1]} \mathbb{P}\left(|T_j \cap S| > \frac{1}{m^{\frac{1}{2}-\delta}}|S|\right) \text{ by union bound} \\
 &= \sum_{j \in [k_1]} \mathbb{P}\left(\sum_{i \in S} X_j^i > \frac{1}{m^{\frac{1}{2}-\delta}}|S|\right) = \sum_{j \in [k_1]} \mathbb{P}\left(\frac{1}{|S|} \sum_{i \in S} X_j^i > \left(1 + \frac{\frac{1}{m^{\frac{1}{2}-\delta}}|S| - 1}{p}\right) p\right) \\
 &\leq \sum_{j \in [k_1]} \mathbb{P}\left(\frac{1}{|S|} \sum_{i \in S} X_j^i > \left(1 + \frac{\frac{1}{m^{\frac{1}{2}-\delta}}}{p}\right) p\right) \\
 &= \sum_{j \in [k_1]} \mathbb{P}\left(\frac{1}{|S|} \sum_{i \in S} X_j^i > (1 + m^\delta) p\right) \text{ since } p = \frac{1}{k_1} = \frac{1}{m^{\frac{1}{2}}} \\
 &\leq \sum_{j \in [k_1]} \exp\left(-\frac{p|S|}{4} m^{2\delta}\right) \text{ by Proposition 2.10} \\
 &\leq \sum_{j \in [k_1]} \exp\left(-\frac{m^\delta}{4} m^{2\delta}\right) \text{ since } p|S| = \frac{|S|}{k_1} \geq m^\delta \\
 &= m^{\frac{1}{2}} e^{-\frac{m^{3\delta}}{4}}.
 \end{aligned} \tag{5.47}$$

Thus, this event occurs with exponentially small probability as well. We have then that for all set  $S$ ,  $\mathbb{P}(v(S) \neq v'(S)) \leq p_{\text{leak}} := m^{\frac{1}{2}} e^{-\frac{m^{3\delta}}{4}}$ , which is an exponentially small bound that does not depend on  $S$ .

Hence, for every set  $S$ , only with exponentially small probability  $p_{\text{leak}}$  can one distinguish between  $v$  and  $v'$ . For some fixed algorithm  $\mathcal{A}$ , let us consider the sequence  $L$  of queries made by  $\mathcal{A}$  before it is able to distinguish between  $v$  and  $v'$ :  $L := (S_1, \dots, S_n)$ , with  $v(S_i) = v'(S_i)$  for  $i \in [n]$  and  $v'(S_{n+1}) > v(S_{n+1})$ .  $L$  is independent of  $T_1, \dots, T_{k_1}$  as no information from this partition is leaked before  $S_{n+1}$ . Thus, for such an algorithm to be correct, it should work for any equi-partition  $T_1, \dots, T_{k_1}$ . We have:

$$\mathbb{P}(\exists i \in [n] : v(S_i) \neq v'(S_i)) \leq \sum_{i=1}^n \mathbb{P}(v(S_i) \neq v'(S_i)) = np_{\text{leak}} \text{ by union bound.}$$

In particular, this implies that:

$$\mathbb{P}(\forall i \in [n] : v(S_i) = v'(S_i)) \geq 1 - np_{\text{leak}}.$$

So, if  $1 - np_{\text{leak}} > 0$ , i.e.  $n < \frac{1}{p_{\text{leak}}}$ , then there exists some equi-partition  $T_1, \dots, T_{k_1}$  such that our algorithm outputs a sequence  $L$  of queries of length  $n$  before being able to distinguish between  $v$  and  $v'$ . In particular, we can take  $n = \frac{1}{2p_{\text{leak}}}$  so that  $L$  is of exponential size. Hence, for any algorithm  $\mathcal{A}$ , there exists some equi-partition  $T_1, \dots, T_{k_1}$  such that  $\mathcal{A}$  needs an exponential number of value queries to distinguish between  $v$  and  $v'$ . This concludes the proof of the theorem for any deterministic algorithm.

Finally, the hardness result holds also for randomized algorithms. Indeed, let us call  $\mathcal{A}_s$ , the running algorithm conditioned on its random bits being  $s$ .  $\mathcal{A}_s$  is deterministic so the

previous proof holds: with high probability  $p$ , the sequence of  $\lfloor \frac{1-p}{p_{leak}} \rfloor$  queries does not reveal anything to distinguish between  $v$  and  $v'$ , although it is of exponential size in  $m$ . Then, averaging over all its random bitstrings, the same result holds, as  $p_{leak}$  is independent of the equi-partition  $T_1, \dots, T_{k_1}$ .  $\square$

### 5.4.3 Limitations of the Model

The main weakness of the previous result is that it highly relies on the restriction that one has access to the data only through value queries. Indeed, if one has access to the full data, it is possible to read the partition  $T_1, \dots, T_{k_1}$  which gives the optimal solution directly. This weakness comes from the fact that our utility function  $f_W^1$  can be described by polynomial-size data, as it is characterized by a broadcast channel  $W$ , whereas one usually consider any XOS functions, in particular with some having inherently an exponential-size defining set of linear valuation functions.

On the other hand, one can also remark that when  $f_W^1$  is written as a maximum of linear valuation functions, then that defining set of linear valuation functions is of exponential size. Hence, we think that it is still relevant to study the value query complexity of such a family of functions, as it is not clear how one could recover the partition in polynomial time from this exponential-size set of linear valuations without any additional information.

## 5.5 Conclusion

In this chapter, we have studied several algorithmic aspects and non-signaling assisted capacity regions of broadcast channels. We have shown that sum success probabilities of the broadcast channel coding problem are the same with and without non-signaling assistance between decoders, and that it implied that non-signaling resource shared between decoders does not change the capacity region. For the class of deterministic broadcast channels, we have described a  $(1 - e^{-1})^2$ -approximation algorithm running in polynomial time, and we have shown that the capacity region for that class is the same with or without non-signaling assistance. Finally, we have shown that in the value query model, we cannot achieve a better approximation ratio than  $\Omega\left(\frac{1}{\sqrt{m}}\right)$  in polynomial time for the general broadcast channel coding problem, with  $m$  the size of one of the outputs of the channel.

Our results suggest that non-signaling assistance could improve the capacity region of general broadcast channels, which is left as a major open question. An intermediate result would be to show that it is NP-hard to approximate the broadcast channel coding problem within any constant ratio, strengthening our hardness result without relying on the value query model. Finally, one could also try to develop approximations algorithms for other sub-classes of broadcast channels, such as semi-deterministic or degraded ones. This could be a crucial step towards showing that the capacity region for those classes is the same with or without non-signaling assistance.

## Conclusion

In this thesis, we have studied several channel coding problems, with and without non-signaling assistance, from the point of view of algorithmic approximation and of capacity regions.

In Chapter 3, we have introduced a generalization of the maximum  $\ell$ -multi-coverage problem which entails maximizing the quantity  $\sum_{a \in [n]} w_a \varphi(|\{i \in S : a \in T_i\}|)$  over subsets  $S \subseteq [m]$  of cardinality  $k$ . We have shown that when  $\varphi$  is normalized, nondecreasing and concave, we can obtain an approximation guarantee given by the *Poisson concavity ratio*  $\alpha_\varphi := \min_{x \in \mathbb{N}^*} \frac{\mathbb{E}[\varphi(\text{Poi}(x))]}{\varphi(\mathbb{E}[\text{Poi}(x)])}$  and we showed it is tight for sublinear functions  $\varphi$  if  $P \neq NP$ . Applied to channel coding, and more specifically to  $\varphi$ -list-decoding, where the length restriction on the list of guesses of the decoder in  $\ell$ -list-decoding is replaced by a probability  $\frac{\varphi(\ell)}{\ell}$  of correctly decoding a list of guesses of variable size  $\ell$ , we have obtained a tight approximation guarantee  $\alpha_\varphi$  for the class of channels  $W$  of the form  $W(y|x) = \frac{1}{t}$  for  $y \in T_x$  with  $|T_x| = t$  and  $W(y|x) = 0$  elsewhere. A natural open question is whether the NP-hardness guarantee can be extended for  $\varphi(n) \neq o(n)$ . Another open problem is to extend the  $\alpha_\varphi$ -approximation algorithm for  $\varphi$ -list-decoding on all channels.

In Chapter 4, we have shown that the multiple-access channel coding problem cannot be approximated within any constant ratio under a complexity hypothesis on random  $k$ -SAT formulas. We have shown that optimal non-signaling assisted codes for multiple-access channels can be found in polynomial time in the number of copies of the channel. Applied to the binary adder channel, a non-signaling advantage on its capacity region has been established. We have provided a general single-letter outer bound on the non-signaling capacity region. When non-signaling assistance is not shared between encoders, we have shown that the capacity region is not changed. A remaining open question is whether quantum entanglement may increase the capacity of the binary adder channel. Also, establishing a single-letter formula for the non-signaling assisted capacity of multiple-access channels is the main open question left here, which could be obtained by achieving the provided single-letter outer bound on the non-signaling capacity region.

In Chapter 5, for the class of deterministic broadcast channels, we have provided a  $(1 - e^{-1})^2$ -approximation algorithm for the unassisted coding problem, and we have shown that their capacity region is not changed with non-signaling assistance. In the value query model, we have shown that we cannot achieve a better approximation ratio than  $\Omega\left(\frac{1}{\sqrt{m}}\right)$  for the general broadcast channel coding problem, with  $m$  the output size of the channel. Our

results suggest that non-signaling assistance could improve the capacity region of general broadcast channels, which is left as a major open question. An intermediate result would be to show that it is NP-hard to approximate the broadcast channel coding problem within any constant ratio, strengthening our hardness result without relying on the value query model.

Throughout this thesis, we have shown that links between approximation algorithms for channel coding and non-signaling assisted capacity regions are fruitful in both directions. On the one hand, the existence of approximation algorithms with constant ratio for channel coding results often in the absence of non-signaling advantage on the related capacity regions. On the other hand, the hardness of approximation within any constant ratio for the channel coding problem results often in the existence of a non-signaling advantage on the related capacity regions. Although not a formal equivalence, this strong link between those apparently unrelated domains may be the key to address unsolved problems from both topics. In particular, the step achieved in the understanding of the influence of non-signaling correlations on broadcast channels, solved now for deterministic channels, goes in that direction, and could be extended to other classes of channels. We believe that this connection deserves more attention. In fact, as the complexity-theoretic point of view on entangled multiplayer games was extremely fruitful [JNV<sup>+</sup>20], we expect the algorithmic study of problems arising in information theory to achieve important insights.

---

## Conclusion

Dans cette thèse, nous avons étudié plusieurs problèmes de codage de canal, avec et sans assistance non-signalante, du point de vue de l'approximation algorithmique et des zones de capacité.

Dans le Chapitre 3, nous avons introduit une généralisation du problème de couverture multiple maximale de paramètre  $\ell$  où l'on maximise  $\sum_{a \in [n]} w_a \varphi(|\{i \in S : a \in T_i\}|)$  sur les sous-ensembles  $\subseteq [m]$  de cardinal  $k$ . Nous avons montré que lorsque  $\varphi$  est normalisée, croissante et concave, nous pouvons obtenir une garantie d'approximation donnée par le *rapport de concavité de Poisson*  $\alpha_\varphi := \min_{x \in \mathbb{N}^*} \frac{\mathbb{E}[\varphi(\text{Poi}(x))]}{\varphi(\mathbb{E}[\text{Poi}(x)])}$  et nous avons montré qu'elle est optimale pour les fonctions sous-linéaires  $\varphi$  si  $\text{P} \neq \text{NP}$ . Appliqué au codage de canal, et plus spécifiquement au décodage de liste de paramètre  $\varphi$ , où la restriction de longueur sur la liste de suppositions du décodeur dans le décodage de liste de paramètre  $\ell$  est remplacée par une probabilité  $\frac{\varphi(\ell)}{\ell}$  de décoder correctement une liste de suppositions de taille variable  $\ell$ , nous avons obtenu une stricte garantie d'approximation  $\alpha_\varphi$  pour la classe de canaux  $W$  de la forme  $W(y|x) = \frac{1}{t}$  pour  $y \in T_x$  avec  $|T_x| = t$  et  $W(y|x) = 0$  ailleurs. Une question ouverte naturelle est de savoir si la garantie de NP-difficulté peut être étendue pour  $\varphi(n) \neq o(n)$ . Un autre problème ouvert consiste à étendre l'algorithme d'approximation  $\alpha_\varphi$  pour le décodage de listes de paramètre  $\varphi$  sur tous les canaux.

Dans le Chapitre 4, nous avons montré que le problème du codage des canaux à accès multiple ne peut être approximé avec un ratio constant sous une hypothèse de complexité sur les formules  $k$ -SAT aléatoires. Nous avons montré que les codes optimaux avec assistance non-signalante pour les canaux à accès multiple peuvent être trouvés en temps polynomial en le nombre de copies du canal. Appliqué au canal additionneur binaire, un avantage non-signalant sur sa zone de capacité a été établi. Nous avons fourni une borne supérieure générale à une seule lettre pour la zone de capacité non-signalante. Lorsque l'assistance non-signalante n'est pas partagée entre les encodeurs, nous avons montré que la zone de capacité n'est pas modifiée. La question de savoir si l'intrication quantique peut augmenter la capacité du canal additionneur binaire reste ouverte. En outre, l'établissement d'une formule à une seule lettre pour la capacité avec assistance non-signalante des canaux à accès multiple reste la principale question ouverte de ce chapitre. Cette dernière pourrait être obtenue en montrant que la borne supérieure à une seule lettre fournie pour la zone de capacité non-signalante peut en fait être atteinte.

Dans le Chapitre 5, pour la classe des canaux de diffusion déterministes, nous avons

fourni un algorithme d'approximation de ratio  $(1 - e^{-1})^2$  pour le problème du codage sans assistance, et nous avons montré que leur zone de capacité n'est pas modifiée par l'assistance non-signalante. Dans le modèle d'accès par valeur, nous avons montré que nous ne pouvons pas obtenir un meilleur ratio d'approximation que  $\Omega\left(\frac{1}{\sqrt{m}}\right)$  pour le problème de codage du canal de diffusion général, avec  $m$  la taille de sortie du canal. Nos résultats suggèrent que l'assistance non-signalante pourrait améliorer la zone de capacité des canaux de diffusion généraux, ce qui reste une question ouverte majeure. Un résultat intermédiaire consisterait à montrer qu'il est NP-difficile d'approximer le problème de codage des canaux de diffusion pour n'importe quel ratio constant, ce qui renforcerait notre résultat de difficulté sans s'appuyer sur le modèle d'accès par valeur.

Tout au long de cette thèse, nous avons montré que les différents liens entre les algorithmes d'approximation pour le codage de canal et les zones de capacité avec assistance non-signalantes sont fructueux dans les deux sens. D'une part, l'existence d'algorithmes d'approximation à rapport constant pour le codage de canal se traduit souvent par l'absence d'avantage non-signalant pour les zones de capacité correspondantes. D'autre part, la difficulté d'approximation pour un ratio constant quelconque pour le problème du codage de canal se traduit souvent par l'existence d'un avantage non-signalant dans les zones de capacité correspondantes. Bien qu'il ne s'agisse pas d'une équivalence formelle, ce lien étroit entre ces domaines apparemment sans rapport peut être la clé pour résoudre des problèmes non résolus dans les deux domaines. En particulier, l'étape franchie dans la compréhension de l'influence des corrélations non-signalantes sur les canaux de diffusion, résolue à présent pour les canaux déterministes, va dans cette direction et pourrait être étendue à d'autres classes de canaux. Nous pensons que ce lien mérite plus d'attention. En fait, comme le point de vue de la théorie de la complexité sur les jeux multijoueurs intriqués a été extrêmement fructueux [JNV<sup>+</sup>20], nous nous attendons à ce que l'étude algorithmique des problèmes posés par la théorie de l'information aboutisse à des résultats importants.

---

# Bibliography

- [AA00] Erling D Andersen and Knud D Andersen. The Mosek interior point optimizer for linear programming: an implementation of the homogeneous algorithm. In *High performance optimization*, pages 197–232. Springer, 2000. doi:10.1007/978-1-4757-3216-0\_8. Citations: § 86
- [AAM<sup>+</sup>11] Noga Alon, Sanjeev Arora, Rajsekar Manokaran, Dana Moshkovitz, and Omri Weinstein. Inapproximability of densest  $\kappa$ -subgraph from average case hardness. *Unpublished manuscript*, 1, 2011. URL: <https://www.tau.ac.il/~nogaa/PDFS/dks8.pdf>. Citations: § 70, 71, 73, and 111
- [AB99] Rudolf Ahlswede and Vladimir B. Balakirsky. Construction of uniquely decodable codes for the two-user binary adder channel. *IEEE Trans. Inf. Theory*, 45(1):326–330, 1999. doi:10.1109/18.746834. Citations: § 86
- [ADR82] Alain Aspect, Jean Dalibard, and Gérard Roger. Experimental test of Bell’s inequalities using time-varying analyzers. *Phys. Rev. Lett.*, 49:1804–1807, Dec 1982. doi:10.1103/PhysRevLett.49.1804. Citations: § 2 and 6
- [Ahl73] Rudolf Ahlswede. Multi-way communication channels. In *2nd International Symposium on Information Theory, Tsahkadsor, Armenia, USSR, September 2-8, 1971*, pages 23–52. Publishing House of the Hungarian Academy of Science, 1973. Citations: § 3, 8, 59, 62, and 111
- [AK75] Rudolf Ahlswede and János Körner. Source coding with side information and a converse for degraded broadcast channels. *IEEE Trans. Inf. Theory*, 21(6):629–637, 1975. doi:10.1109/TIT.1975.1055469. Citations: § 111
- [Ara02] PK Aravind. A simple demonstration of Bell’s theorem involving two observers and no probabilities or inequalities. *CoRR*, abs/quant-ph/0206070, 2002. arXiv:quant-ph/0206070. Citations: § 59
- [Ari09] Erdal Arıkan. Channel polarization: a method for constructing capacity-achieving codes for symmetric binary-input memoryless channels. *IEEE Trans. Inf. Theory*, 55(7):3051–3073, 2009. doi:10.1109/TIT.2009.2021379. Citations: § 1 and 5
- [AS04] Alexander A. Ageev and Maxim Sviridenko. Pipage rounding: A new method of constructing algorithms with proven performance guarantee. *J. Comb. Optim.*, 8(3):307–328, 2004. doi:10.1023/B:JOCO.0000038913.96607.c2. Citations: § 25 and 26
- [BB98] Shraga I. Bross and Ian F. Blake. Upper bound for uniquely decodable codes in a binary input N-user adder channel. *IEEE Trans. Inf. Theory*, 44(1):334–340, 1998. doi:10.1109/18.651062. Citations: § 86

## BIBLIOGRAPHY

---

- [BBBE71] Max Born, Hedwig Born, Irene Born, and Albert Einstein. *The Born–Einstein letters: correspondence between Albert Einstein and Max and Hedwig Born from 1916 to 1955*. Walker, 1971. Citations: § 2 and 6
- [BBC<sup>+</sup>93] Charles H. Bennett, Gilles Brassard, Claude Crépeau, Richard Jozsa, Asher Peres, and William K. Wootters. Teleporting an unknown quantum state via dual classical and einstein-podolsky-rosen channels. *Phys. Rev. Lett.*, 70:1895–1899, Mar 1993. doi:[10.1103/PhysRevLett.70.1895](https://doi.org/10.1103/PhysRevLett.70.1895). Citations: § 2, 7, and 59
- [BBT05] Gilles Brassard, Anne Broadbent, and Alain Tapp. Quantum pseudo-telepathy. *Foundations of Physics*, 35(11):1877–1907, 2005. doi:[10.1007/s10701-005-7353-4](https://doi.org/10.1007/s10701-005-7353-4). Citations: § 59
- [BCE<sup>+</sup>16] Felix Brandt, Vincent Conitzer, Ulle Endriss, Jérôme Lang, and Ariel D. Procaccia, editors. *Handbook of Computational Social Choice*. Cambridge University Press, 2016. doi:[10.1017/CB09781107446984](https://doi.org/10.1017/CB09781107446984). Citations: § 35
- [BCP<sup>+</sup>14] Nicolas Brunner, Daniel Cavalcanti, Stefano Pironio, Valerio Scarani, and Stephanie Wehner. Bell nonlocality. *Rev. Mod. Phys.*, 86:419–478, Apr 2014. doi:[10.1103/RevModPhys.86.419](https://doi.org/10.1103/RevModPhys.86.419). Citations: § 3, 7, and 59
- [Bel64] J. S. Bell. On the Einstein Podolsky Rosen paradox. *Physics Physique Fizika*, 1:195–200, Nov 1964. doi:[10.1103/PhysicsPhysiqueFizika.1.195](https://doi.org/10.1103/PhysicsPhysiqueFizika.1.195). Citations: § 2 and 6
- [Ber73] Patrick P. Bergmans. Random coding theorem for broadcast channels with degraded components. *IEEE Trans. Inf. Theory*, 19(2):197–207, 1973. doi:[10.1109/TIT.1973.1054980](https://doi.org/10.1109/TIT.1973.1054980). Citations: § 111
- [BF18] Siddharth Barman and Omar Fawzi. Algorithmic aspects of optimal channel coding. *IEEE Trans. Inf. Theory*, 64(2):1038–1045, 2018. doi:[10.1109/TIT.2017.2696963](https://doi.org/10.1109/TIT.2017.2696963). Citations: § 1, 3, 5, 7, 19, 20, 21, 22, 59, 70, 105, 111, 112, and 133
- [BFF21] Siddharth Barman, Omar Fawzi, and Paul Fermé. Tight approximation guarantees for concave coverage problems. In Markus Bläser and Benjamin Monmege, editors, *38th International Symposium on Theoretical Aspects of Computer Science, STACS 2021, March 16-19, 2021, Saarbrücken, Germany (Virtual Conference)*, volume 187 of *LIPICs*, pages 9:1–9:17. Schloss Dagstuhl - Leibniz-Zentrum für Informatik, 2021. doi:[10.4230/LIPICs.STACS.2021.9](https://doi.org/10.4230/LIPICs.STACS.2021.9). Citations: § 4 and 8
- [BFGG20] Siddharth Barman, Omar Fawzi, Suprovat Ghoshal, and Emirhan Gürpınar. Tight approximation bounds for maximum multi-coverage. In Daniel Bienstock and Giacomo Zambelli, editors, *Integer Programming and Combinatorial Optimization - 21st International Conference, IPCO 2020, London, UK, June 8-10, 2020, Proceedings*, volume 12125 of *Lecture Notes in Computer Science*, pages 66–77. Springer, 2020. doi:[10.1007/978-3-030-45771-6\\_6](https://doi.org/10.1007/978-3-030-45771-6_6). Citations: § 1, 2, 6, 12, 22, 24, 25, 26, 29, 41, and 111
- [BG96] Claude Berrou and Alain Glavieux. Near optimum error correcting coding and decoding: turbo-codes. *IEEE Trans. Commun.*, 44(10):1261–1271, 1996. doi:[10.1109/26.539767](https://doi.org/10.1109/26.539767). Citations: § 1 and 5
- [BH84] Andrew D Barbour and Peter Hall. On the rate of Poisson convergence. *Mathematical Proceedings of the Cambridge Philosophical Society*, 95(3):473–480, 1984. doi:[10.1017/S0305004100061806](https://doi.org/10.1017/S0305004100061806). Citations: § 49
- [BLS17] Markus Brill, Jean-François Laslier, and Piotr Skowron. Multiwinner approval rules as apportionment methods. In Satinder P. Singh and Shaul Markovitch, editors, *Proceedings of the Thirty-First AAAI Conference on Artificial Intelligence, February 4-9, 2017, San Francisco, California, USA*, pages 414–420. AAAI Press, 2017. doi:[10.1177/0951629818775518](https://doi.org/10.1177/0951629818775518). Citations: § 23



- [BN05] Liad Blumrosen and Noam Nisan. On the computational power of iterative auctions. In John Riedl, Michael J. Kearns, and Michael K. Reiter, editors, *Proceedings 6th ACM Conference on Electronic Commerce (EC-2005), Vancouver, BC, Canada, June 5-8, 2005*, pages 29–43. ACM, 2005. doi:10.1145/1064009.1064013. Citations: § 112
- [BSST99] Charles H Bennett, Peter W Shor, John A Smolin, and Ashish V Thapliyal. Entanglement-assisted classical capacity of noisy quantum channels. *Physical Review Letters*, 83(15):3081, 1999. doi:10.1103/PhysRevLett.83.3081. Citations: § 2, 7, and 59
- [BT96] Steven J. Brams and Alan D. Taylor. *Fair division - from cake-cutting to dispute resolution*. Cambridge University Press, 1996. Citations: § 112
- [BW92] Charles H. Bennett and Stephen J. Wiesner. Communication via one- and two-particle operators on Einstein-Podolsky-Rosen states. *Phys. Rev. Lett.*, 69:2881–2884, Nov 1992. doi:10.1103/PhysRevLett.69.2881. Citations: § 2 and 6
- [Can17] Clément L Canonne. A short note on Poisson tail bounds. Retrieved from the website: <http://www.cs.columbia.edu/~ccanonne>, 2017. Citations: § 42
- [CC84] Michele Conforti and Gérard Cornuéjols. Submodular set functions, matroids and the greedy algorithm: Tight worst-case bounds and some generalizations of the Rado-Edmonds theorem. *Discret. Appl. Math.*, 7(3):251–274, 1984. doi:10.1016/0166-218X(84)90003-9. Citations: § 24
- [CCK<sup>+</sup>17] Parinya Chalermsook, Marek Cygan, Guy Kortsarz, Bundit Laekhanukit, Pasin Manurangsi, Danupon Nanongkai, and Luca Trevisan. From Gap-ETH to FPT-inapproximability: Clique, dominating set, and more. In Chris Umans, editor, *58th IEEE Annual Symposium on Foundations of Computer Science, FOCS 2017, Berkeley, CA, USA, October 15-17, 2017*, pages 743–754. IEEE Computer Society, 2017. doi:10.1109/FOCS.2017.74. Citations: § 25 and 34
- [CCPV11] Gruiă Călinescu, Chandra Chekuri, Martin Pál, and Jan Vondrák. Maximizing a monotone submodular function subject to a matroid constraint. *SIAM J. Comput.*, 40(6):1740–1766, 2011. doi:10.1137/080733991. Citations: § 26
- [CFN77] Gérard Cornuéjols, Marshall L Fisher, and George L Nemhauser. Exceptional paper—location of bank accounts to optimize float: An analytic study of exact and approximate algorithms. *Management science*, 23(8):789–810, 1977. doi:10.1287/mnsc.23.8.789. Citations: § 21 and 23
- [Cha77] Gregory J. Chaitin. Algorithmic information theory. *IBM J. Res. Dev.*, 21(4):350–359, 1977. doi:10.1147/rd.214.0350. Citations: § 1 and 5
- [CHSH69] John F. Clauser, Michael A. Horne, Abner Shimony, and Richard A. Holt. Proposed experiment to test local hidden-variable theories. *Phys. Rev. Lett.*, 23:880–884, Oct 1969. doi:10.1103/PhysRevLett.23.880. Citations: § 2, 3, 6, and 7
- [Cir80] Boris S. Cirel’son. Quantum generalizations of Bell’s inequality. *Letters in Mathematical Physics*, 4(2):93–100, Mar 1980. doi:10.1007/BF00417500. Citations: § 2, 3, and 7
- [CLMW10] Toby S. Cubitt, Debbie Leung, William Matthews, and Andreas Winter. Improving zero-error classical communication with entanglement. *Phys. Rev. Lett.*, 104:230503, Jun 2010. doi:10.1103/PhysRevLett.104.230503. Citations: § 2 and 7
- [Cov72] Thomas M. Cover. Broadcast channels. *IEEE Trans. Inf. Theory*, 18(1):2–14, 1972. doi:10.1109/TIT.1972.1054727. Citations: § 3, 8, and 111
- [Cov75] Thomas M. Cover. An achievable rate region for the broadcast channel. *IEEE Transactions on Information Theory*, 21(4):399–404, 1975. doi:10.1109/TIT.1975.1055418. Citations: § 111

## BIBLIOGRAPHY

---

- [CPM19] Rahul Chandan, Dario Paccagnan, and Jason R. Marden. Optimal mechanisms for distributed resource-allocation. *CoRR*, abs/1911.07823, 2019. [arXiv:1911.07823](https://arxiv.org/abs/1911.07823). Citations: § 23 and 38
- [CRBT22] Michael X. Cao, Navneeth Ramakrishnan, Mario Berta, and Marco Tomamichel. Channel simulation: Finite blocklengths and broadcast channels. *CoRR*, abs/2212.11666, 2022. [arXiv:2212.11666](https://arxiv.org/abs/2212.11666), [doi:10.48550/arXiv.2212.11666](https://doi.org/10.48550/arXiv.2212.11666). Citations: § 3 and 7
- [CT01] Thomas M. Cover and Joy A. Thomas. *Elements of Information Theory*. Wiley, 2001. [doi:10.1002/0471200611](https://doi.org/10.1002/0471200611). Citations: § 35 and 62
- [DMMS20] Szymon Dudycz, Pasin Manurangsi, Jan Marcinkowski, and Krzysztof Sornat. Tight approximation for proportional approval voting. In Christian Bessiere, editor, *Proceedings of the Twenty-Ninth International Joint Conference on Artificial Intelligence, IJCAI 2020*, pages 276–282. [ijcai.org](https://www.ijcai.org), 2020. [doi:10.24963/ijcai.2020/39](https://doi.org/10.24963/ijcai.2020/39). Citations: § 23, 24, 25, 37, 41, 51, and 55
- [DR98] Devdatt P. Dubhashi and Desh Ranjan. Balls and bins: A study in negative dependence. *Random Struct. Algorithms*, 13(2):99–124, 1998. [doi:10.7146/brics.v3i25.20006](https://doi.org/10.7146/brics.v3i25.20006). Citations: § 13
- [DS06] Shahar Dobzinski and Michael Schapira. An improved approximation algorithm for combinatorial auctions with submodular bidders. In *Proceedings of the Seventeenth Annual ACM-SIAM Symposium on Discrete Algorithms, SODA 2006, Miami, Florida, USA, January 22-26, 2006*, pages 1064–1073. ACM Press, 2006. URL: <http://dl.acm.org/citation.cfm?id=1109557.1109675>. Citations: § 112, 134, and 135
- [DV15] Shaddin Dughmi and Jan Vondrák. Limitations of randomized mechanisms for combinatorial auctions. *Games Econ. Behav.*, 92:370–400, 2015. [doi:10.1016/j.geb.2014.01.007](https://doi.org/10.1016/j.geb.2014.01.007). Citations: § 21
- [Eli57] Peter Elias. List decoding for noisy channels. *Technical Report*, 335, 1957. URL: <https://dspace.mit.edu/bitstream/handle/1721.1/4484/RLE-TR-335-04734756.pdf>. Citations: § 1, 5, 22, and 35
- [EPR35] A. Einstein, B. Podolsky, and N. Rosen. Can quantum-mechanical description of physical reality be considered complete? *Phys. Rev.*, 47:777–780, May 1935. [doi:10.1103/PhysRev.47.777](https://doi.org/10.1103/PhysRev.47.777). Citations: § 2 and 6
- [Fei98] Uriel Feige. A threshold of  $\ln n$  for approximating set cover. *J. ACM*, 45(4):634–652, 1998. [doi:10.1145/285055.285059](https://doi.org/10.1145/285055.285059). Citations: § 1, 5, 21, 25, and 29
- [Fei02] Uriel Feige. Relations between average case complexity and approximation complexity. In John H. Reif, editor, *Proceedings on 34th Annual ACM Symposium on Theory of Computing, May 19-21, 2002, Montréal, Québec, Canada*, pages 534–543. ACM, 2002. [doi:10.1145/509907.509985](https://doi.org/10.1145/509907.509985). Citations: § 70
- [FF22] Omar Fawzi and Paul Fermé. Beating the sum-rate capacity of the binary adder channel with non-signaling correlations. In *IEEE International Symposium on Information Theory, ISIT 2022, Espoo, Finland, June 26 - July 1, 2022*, pages 2750–2755. IEEE, 2022. [doi:10.1109/ISIT50566.2022.9834699](https://doi.org/10.1109/ISIT50566.2022.9834699). Citations: § 4 and 8
- [FF23] Omar Fawzi and Paul Fermé. Multiple-access channel coding with non-signaling correlations. pages 1–1, 2023. [doi:10.1109/TIT.2023.3301719](https://doi.org/10.1109/TIT.2023.3301719). Citations: § 4 and 8
- [FK14] Vitaly Feldman and Pravesh Kothari. Learning coverage functions and private release of marginals. In Maria-Florina Balcan, Vitaly Feldman, and Csaba Szepesvári, editors, *Proceedings of The 27th Conference on Learning Theory, COLT 2014, Barcelona, Spain, June 13-15, 2014*, volume 35 of *JMLR Workshop and Conference Proceedings*, pages 679–702. JMLR.org, 2014. URL: <http://proceedings.mlr.press/v35/feldman14a.html>. Citations: § 21

- [FKP01] Uriel Feige, Guy Kortsarz, and David Peleg. The dense  $k$ -subgraph problem. *Algorithmica*, 29(3):410–421, 2001. doi:[10.1007/s004530010050](https://doi.org/10.1007/s004530010050). Citations: § 70 and 111
- [FW10] Manuel Fernández and Stuart Williams. Closed-form expression for the Poisson-binomial probability density function. *IEEE Transactions on Aerospace and Electronic Systems*, 46(2):803–817, 2010. doi:[10.1109/TAES.2010.5461658](https://doi.org/10.1109/TAES.2010.5461658). Citations: § 49
- [Gal62] Robert G. Gallager. Low-density parity-check codes. *IRE Trans. Inf. Theory*, 8(1):21–28, 1962. doi:[10.1109/TIT.1962.1057683](https://doi.org/10.1109/TIT.1962.1057683). Citations: § 1 and 5
- [Gal74] R.G. Gallager. Capacity and coding for degraded broadcast channels. *Problemy Peredachi Informatsii*, 10(3):3–14, 1974. Citations: § 111
- [GJ79] M. R. Garey and David S. Johnson. *Computers and Intractability: A Guide to the Theory of NP-Completeness*. W. H. Freeman, 1979. Citations: § 126
- [GK11] Abbas El Gamal and Young-Han Kim. *Network Information Theory*. Cambridge University Press, 2011. doi:[10.1017/CB09781139030687](https://doi.org/10.1017/CB09781139030687). Citations: § 15 and 16
- [GM07] Bernd Gärtner and Jirí Matousek. *Understanding and using linear programming*. Universitext. Springer, 2007. doi:[10.1007/978-3-540-30717-4](https://doi.org/10.1007/978-3-540-30717-4). Citations: § 66, 81, and 120
- [GN20] Amin Gohari and Chandra Nair. New outer bounds for the two-receiver broadcast channel. In *IEEE International Symposium on Information Theory, ISIT 2020, Los Angeles, CA, USA, June 21-26, 2020*, pages 1492–1497. IEEE, 2020. doi:[10.1109/ISIT44484.2020.9174003](https://doi.org/10.1109/ISIT44484.2020.9174003). Citations: § 111
- [GP80] Sergei Izrail’evich Gel’fand and Mark Semenovich Pinsker. Capacity of a broadcast channel with one deterministic component. *Problemy Peredachi Informatsii*, 16(1):24–34, 1980. Citations: § 111
- [HDW08] Min-Hsiu Hsieh, Igor Devetak, and Andreas J. Winter. Entanglement-assisted capacity of quantum multiple-access channels. *IEEE Trans. Inf. Theory*, 54(7):3078–3090, 2008. doi:[10.1109/TIT.2008.924726](https://doi.org/10.1109/TIT.2008.924726). Citations: § 60
- [Hoc97] Dorit S. Hochbaum. Approximation algorithms for NP-hard problems. *SIGACT News*, 28(2):40–52, 1997. doi:[10.1145/261342.571216](https://doi.org/10.1145/261342.571216). Citations: § 21
- [Hoe63] Wassily Hoeffding. Probability inequalities for sums of bounded random variables. *Journal of the American Statistical Association*, 58(301):13–30, 1963. doi:[10.1080/01621459.1963.10500830](https://doi.org/10.1080/01621459.1963.10500830). Citations: § 13
- [Hol73] Alexander Semenovich Holevo. Bounds for the quantity of information transmitted by a quantum communication channel. *Problemy Peredachi Informatsii*, 9(3):3–11, 1973. Citations: § 2 and 6
- [Hop81] Grace Murray Hopper. The first bug. *Annals of the History of Computing*, 3(3):285–286, 1981. Citations: § 1 and 5
- [JDP83] Kumar Joag-Dev and Frank Proschan. Negative association of random variables with applications. *The Annals of Statistics*, pages 286–295, 1983. doi:[10.1214/aos/1176346079](https://doi.org/10.1214/aos/1176346079). Citations: § 12
- [Jen06] Johan Ludwig William Valdemar Jensen. Sur les fonctions convexes et les inégalités entre les valeurs moyennes. *Acta mathematica*, 30(1):175–193, 1906. doi:[10.1007/BF02418571](https://doi.org/10.1007/BF02418571). Citations: § 11
- [JNV<sup>+</sup>20] Zhengfeng Ji, Anand Natarajan, Thomas Vidick, John Wright, and Henry Yuen. MIP\*=RE. *CoRR*, abs/2001.04383, 2020. URL: <https://arxiv.org/abs/2001.04383>, [arXiv:2001.04383](https://arxiv.org/abs/2001.04383). Citations: § 60, 142, and 144
- [Jr.78] E. J. Weldon Jr. Coding for a multiple-access channel. *Inf. Control.*, 36(3):256–274, 1978. doi:[10.1016/S0019-9958\(78\)90312-1](https://doi.org/10.1016/S0019-9958(78)90312-1). Citations: § 86

## BIBLIOGRAPHY

---

- [Kho02] Subhash Khot. On the power of unique 2-prover 1-round games. In John H. Reif, editor, *Proceedings on 34th Annual ACM Symposium on Theory of Computing, May 19-21, 2002, Montréal, Québec, Canada*, pages 767–775. ACM, 2002. doi:[10.1145/509907.510017](https://doi.org/10.1145/509907.510017). Citations: § 2 and 6
- [KL78] Tadao Kasami and Shu Lin. Bounds on the achievable rates of block coding for a memoryless multiple-access channel. *IEEE Trans. Inf. Theory*, 24(2):187–197, 1978. doi:[10.1109/TIT.1978.1055860](https://doi.org/10.1109/TIT.1978.1055860). Citations: § 86
- [KLWY83] Tadao Kasami, Shu Lin, Victor K.-W. Wei, and Saburo Yamamura. Graph theoretic approaches to the code construction for the two-user multiple-access binary adder channel. *IEEE Trans. Inf. Theory*, 29(1):114–130, 1983. doi:[10.1109/TIT.1983.1056614](https://doi.org/10.1109/TIT.1983.1056614). Citations: § 86 and 87
- [LALS20] Felix Leditzky, Mohammad A Alhejji, Joshua Levin, and Graeme Smith. Playing games with multiple access channels. *Nature communications*, 11(1):1–5, 2020. doi:[10.1038/s41467-020-15240-w](https://doi.org/10.1038/s41467-020-15240-w). Citations: § 3, 8, 59, 70, and 111
- [Lia73] Henry Herng-Jiunn Liao. Multiple access channels (Ph.D. Thesis abstr.). *IEEE Trans. Inf. Theory*, 19(2):253, 1973. doi:[10.1109/TIT.1973.1054960](https://doi.org/10.1109/TIT.1973.1054960). Citations: § 3, 8, 59, 62, and 111
- [Lin69] Bernt Lindström. Determination of two vectors from the sum. *Journal of Combinatorial Theory*, 6(4):402–407, 1969. doi:[10.1016/S0021-9800\(69\)80038-4](https://doi.org/10.1016/S0021-9800(69)80038-4). Citations: § 86
- [Man20] Pasin Manurangsi. Tight running time lower bounds for strong inapproximability of maximum  $k$ -coverage, unique set cover and related problems (via  $t$ -wise agreement testing theorem). In Shuchi Chawla, editor, *Proceedings of the 2020 ACM-SIAM Symposium on Discrete Algorithms, SODA 2020, Salt Lake City, UT, USA, January 5-8, 2020*, pages 62–81. SIAM, 2020. doi:[10.1137/1.9781611975994.5](https://doi.org/10.1137/1.9781611975994.5). Citations: § 24 and 34
- [Mar77] Katalin Marton. The capacity region of deterministic broadcast channels. In *Trans. Int. Symp. Inform. Theory*, pages 243–248, 1977. Citations: § 111
- [Mar79] Katalin Marton. A coding theorem for the discrete memoryless broadcast channel. *IEEE Trans. Inf. Theory*, 25(3):306–311, 1979. doi:[10.1109/TIT.1979.1056046](https://doi.org/10.1109/TIT.1979.1056046). Citations: § 111
- [Mat12] William Matthews. A linear program for the finite block length converse of Polyanskiy-Poor-Verdú via nonsignaling codes. *IEEE Trans. Inf. Theory*, 58(12):7036–7044, 2012. doi:[10.1109/TIT.2012.2210695](https://doi.org/10.1109/TIT.2012.2210695). Citations: § 3, 7, 59, and 96
- [Mer90] N David Mermin. Simple unified form for the major no-hidden-variables theorems. *Physical review letters*, 65(27):3373, 1990. doi:[10.1103/PhysRevLett.65.3373](https://doi.org/10.1103/PhysRevLett.65.3373). Citations: § 59
- [MÖ05] M. Mattas and Patric R. J. Östergård. A new bound for the zero-error capacity region of the two-user binary adder channel. *IEEE Trans. Inf. Theory*, 51(9):3289–3291, 2005. doi:[10.1109/TIT.2005.853309](https://doi.org/10.1109/TIT.2005.853309). Citations: § 86 and 87
- [Mou03] Hervé Moulin. *Fair division and collective welfare*. MIT Press, 2003. Citations: § 112
- [MSV08] Vahab S. Mirrokni, Michael Schapira, and Jan Vondrák. Tight information-theoretic lower bounds for welfare maximization in combinatorial auctions. In Lance Fortnow, John Riedl, and Tuomas Sandholm, editors, *Proceedings 9th ACM Conference on Electronic Commerce (EC-2008), Chicago, IL, USA, June 8-12, 2008*, pages 70–77. ACM, 2008. doi:[10.1145/1386790.1386805](https://doi.org/10.1145/1386790.1386805). Citations: § 112, 134, and 135
- [Mur00] Robert A Murphey. Target-based weapon target assignment problems. In *Nonlinear assignment problems*, pages 39–53. Springer, 2000. doi:[10.1007/978-1-4757-3155-2\\_3](https://doi.org/10.1007/978-1-4757-3155-2_3). Citations: § 23 and 38

- [MW08] Jason R. Marden and Adam Wierman. Distributed welfare games with applications to sensor coverage. In *Proceedings of the 47th IEEE Conference on Decision and Control, CDC 2008, December 9-11, 2008, Cancún, Mexico*, pages 1708–1713. IEEE, 2008. doi:[10.1109/CDC.2008.4738800](https://doi.org/10.1109/CDC.2008.4738800). Citations: § 23
- [ND20] Janis Nötzel and Stephen Diadamo. Entanglement-enabled communication for the internet of things. In Mohammad S. Obaidat, Kuei-Fang Hsiao, Petros Nicopolitidis, and Daniel Cascado Caballero, editors, *International Conference on Computer, Information and Telecommunication Systems, CITS 2020, Hangzhou, China, October 5-7, 2020*, pages 1–6. IEEE, 2020. doi:[10.1109/CITS49457.2020.9232550](https://doi.org/10.1109/CITS49457.2020.9232550). Citations: § 59
- [NG07] Chandra Nair and Abbas El Gamal. An outer bound to the capacity region of the broadcast channel. *IEEE Trans. Inf. Theory*, 53(1):350–355, 2007. doi:[10.1109/TIT.2006.887492](https://doi.org/10.1109/TIT.2006.887492). Citations: § 111
- [Noe20] Janis Noetzel. Entanglement-enabled communication. *IEEE J. Sel. Areas Inf. Theory*, 1(2):401–415, 2020. doi:[10.1109/jsait.2020.3017121](https://doi.org/10.1109/jsait.2020.3017121). Citations: § 59
- [NRTV07] Noam Nisan, Tim Roughgarden, Éva Tardos, and Vijay V. Vazirani, editors. *Algorithmic Game Theory*. Cambridge University Press, 2007. doi:[10.1017/CB09780511800481](https://doi.org/10.1017/CB09780511800481). Citations: § 35 and 39
- [OS15] Or Ordentlich and Ofer Shayevitz. A VC-dimension-based outer bound on the zero-error capacity of the binary adder channel. In *IEEE International Symposium on Information Theory, ISIT 2015, Hong Kong, China, June 14-19, 2015*, pages 2366–2370. IEEE, 2015. doi:[10.1109/ISIT.2015.7282879](https://doi.org/10.1109/ISIT.2015.7282879). Citations: § 86
- [PDB21] Uzi Pereg, Christian Deppe, and Holger Boche. Quantum broadcast channels with cooperating decoders: An information-theoretic perspective on quantum repeaters. *Journal of Mathematical Physics*, 62(6):062204, 06 2021. arXiv:[2011.09233](https://arxiv.org/abs/2011.09233), doi:[10.1063/5.0038083](https://doi.org/10.1063/5.0038083). Citations: § 111, 112, and 118
- [PDB23] Uzi Pereg, Christian Deppe, and Holger Boche. The multiple-access channel with entangled transmitters. *CoRR*, abs/2303.10456, 2023. arXiv:[2303.10456](https://arxiv.org/abs/2303.10456), doi:[10.48550/arXiv.2303.10456](https://doi.org/10.48550/arXiv.2303.10456). Citations: § 60
- [Pee03] René Peeters. The maximum edge biclique problem is NP-complete. *Discret. Appl. Math.*, 131(3):651–654, 2003. doi:[10.1016/S0166-218X\(03\)00333-0](https://doi.org/10.1016/S0166-218X(03)00333-0). Citations: § 70
- [Per90] Asher Peres. Incompatible results of quantum measurements. *Physics Letters A*, 151(3-4):107–108, 1990. doi:[10.1016/0375-9601\(90\)90172-K](https://doi.org/10.1016/0375-9601(90)90172-K). Citations: § 59
- [Pin78] Mark Semenovich Pinsker. Capacity of noiseless broadcast channel. *Problemy Peredachi Informatsii*, 14(2):28–34, 1978. Citations: § 111
- [PLM<sup>+</sup>11] R. Prevedel, Y. Lu, W. Matthews, R. Kaltenbaek, and K. J. Resch. Entanglement-enhanced classical communication over a noisy classical channel. *Phys. Rev. Lett.*, 106:110505, Mar 2011. doi:[10.1103/PhysRevLett.106.110505](https://doi.org/10.1103/PhysRevLett.106.110505). Citations: § 2, 7, and 59
- [PM18] Dario Paccagnan and Jason R Marden. Utility design for distributed resource allocation—part II: Applications to submodular, covering, and supermodular problems. *CoRR*, abs/1807.01343, 2018. arXiv:[1807.01343](https://arxiv.org/abs/1807.01343). Citations: § 23, 37, 38, 39, and 40
- [PPV10] Yury Polyanskiy, H. Vincent Poor, and Sergio Verdú. Channel coding rate in the finite blocklength regime. *IEEE Trans. Inf. Theory*, 56(5):2307–2359, 2010. doi:[10.1109/TIT.2010.2043769](https://doi.org/10.1109/TIT.2010.2043769). Citations: § 96 and 98
- [PR94] Sandu Popescu and Daniel Rohrlich. Quantum nonlocality as an axiom. *Foundations of Physics*, 24(3):379–385, 1994. doi:[10.1007/BF02058098](https://doi.org/10.1007/BF02058098). Citations: § 2, 3, and 7
- [QS17] Yihui Quek and Peter W. Shor. Quantum and superquantum enhancements to two-sender, two-receiver channels. *Phys. Rev. A*, 95:052329, May 2017. doi:[10.1103/PhysRevA.95.052329](https://doi.org/10.1103/PhysRevA.95.052329). Citations: § 3, 8, 59, and 111

## BIBLIOGRAPHY

---

- [RU08] Thomas J. Richardson and Rüdiger L. Urbanke. *Modern Coding Theory*. Cambridge University Press, 2008. doi:10.1017/cbo9780511791338. Citations: § 1 and 5
- [RWW06] Renato Renner, Stefan Wolf, and Jürg Wullschleger. The single-serving channel capacity. In *Proceedings 2006 IEEE International Symposium on Information Theory, ISIT 2006, The Westin Seattle, Seattle, Washington, USA, July 9-14, 2006*, pages 1424–1427. IEEE, 2006. doi:10.1109/ISIT.2006.262081. Citations: § 1 and 5
- [Sat78] Hiroshi Sato. An outer bound to the capacity region of broadcast channels (corresp.). *IEEE Trans. Inf. Theory*, 24(3):374–377, 1978. doi:10.1109/TIT.1978.1055883. Citations: § 111
- [SFL16] Piotr Skowron, Piotr Faliszewski, and Jérôme Lang. Finding a collective set of items: From proportional multirepresentation to group recommendation. *Artif. Intell.*, 241:191–216, 2016. doi:10.1016/j.artint.2016.09.003. Citations: § 23
- [Sha48] Claude E. Shannon. A mathematical theory of communication. *Bell Syst. Tech. J.*, 27(3):379–423, 1948. doi:10.1002/j.1538-7305.1948.tb01338.x. Citations: § 1, 5, and 111
- [Sha61] Claude E. Shannon. Two-way communication channels. In *Proceedings of the Fourth Berkeley Symposium on Mathematical Statistics and Probability, Volume 1: Contributions to the Theory of Statistics*, volume 4, pages 611–645. University of California Press, 1961. Citations: § 3 and 8
- [SLSS22] Akshay Seshadri, Felix Leditzky, Vikesh Siddhu, and Graeme Smith. On the separation of correlation-assisted sum capacities of multiple access channels. In *IEEE International Symposium on Information Theory, ISIT 2022, Espoo, Finland, June 26 - July 1, 2022*, pages 2756–2761. IEEE, 2022. doi:10.1109/ISIT50566.2022.9834459. Citations: § 3, 8, 59, and 111
- [SS07] Moshe Shaked and J George Shanthikumar. *Stochastic orders*. Springer Science & Business Media, 2007. doi:10.1007/978-0-387-34675-5. Citations: § 12
- [SVW17] Maxim Sviridenko, Jan Vondrák, and Justin Ward. Optimal approximation for submodular and supermodular optimization with bounded curvature. *Math. Oper. Res.*, 42(4):1197–1218, 2017. doi:10.1287/moor.2016.0842. Citations: § 24, 39, 40, 41, and 47
- [TBR16] Marco Tomamichel, Mario Berta, and Joseph M Renes. Quantum coding with finite resources. *Nature communications*, 7(1):11419, 2016. doi:10.1038/ncomms11419. Citations: § 1 and 5
- [Tom12] Marco Tomamichel. *A framework for non-asymptotic quantum information theory*. PhD thesis, ETH Zürich, 2012. doi:10.48550/arXiv.1203.2142. Citations: § 1 and 5
- [TT19] Wenpin Tang and Fengmin Tang. The Poisson binomial distribution—old & new. *CoRR*, abs/1908.10024, 2019. arXiv:1908.10024. Citations: § 49
- [UL98] Rüdiger Urbanke and Quinn Li. The zero-error capacity region of the 2-user synchronous BAC is strictly smaller than its Shannon capacity region. In *1998 Information Theory Workshop (Cat. No. 98EX131)*, page 61. IEEE, 1998. doi:10.1109/ITW.1998.706434. Citations: § 86
- [vdBvT85] P. A. B. M. Coebergh van den Braak and Henk C. A. van Tilborg. A family of good uniquely decodable code pairs for the two-access binary adder channel. *IEEE Trans. Inf. Theory*, 31(1):3–9, 1985. doi:10.1109/TIT.1985.1057004. Citations: § 86 and 87
- [vdM75] Edward C. van der Meulen. Random coding theorems for the general discrete memoryless broadcast channel. *IEEE Trans. Inf. Theory*, 21(2):180–190, 1975. doi:10.1109/TIT.1975.1055347. Citations: § 111

- 
- [Von07] Jan Vondrák. Submodularity in Combinatorial Optimization. *Univerzita Karlova, Matematicko-Fyzikální Fakulta*, 2007. URL: <https://dspace.cuni.cz/bitstream/handle/20.500.11956/13738/140038775.pdf>. Citations: § 26, 28, and 39
- [Von08] Jan Vondrák. Optimal approximation for the submodular welfare problem in the value oracle model. In Cynthia Dwork, editor, *Proceedings of the 40th Annual ACM Symposium on Theory of Computing, Victoria, British Columbia, Canada, May 17-20, 2008*, pages 67–74. ACM, 2008. doi:10.1145/1374376.1374389. Citations: § 126 and 128
- [vT78] Henk C. A. van Tilborg. An upper bound for codes in a two-access binary erasure channel (Corresp.). *IEEE Trans. Inf. Theory*, 24(1):112–116, 1978. doi:10.1109/TIT.1978.1055814. Citations: § 86
- [Wil90] F.M.J. Willems. The maximal-error and average-error capacity region of the broadcast channel are identical : A direct proof. *Problems of Control and Information Theory*, 19(4):339–347, December 1990. URL: <https://research.tue.nl/nl/publications/the-maximal-error-and-average-error-capacity-region-of-the-broadc>. Citations: § 115
- [Woz58] John M Wozencraft. List decoding. *Quarterly Progress Report*, 48:90–95, 1958. Citations: § 1, 5, 22, and 35
- [YRB20] Jiyoun Yun, Ashutosh Rai, and Joonwoo Bae. Nonlocal network coding in interference channels. *Physical Review Letters*, 125(15):150502, 2020. doi:10.1103/PhysRevLett.125.150502. Citations: § 59
- [YRB23] Jiyoun Yun, Ashutosh Rai, and Joonwoo Bae. Non-local and quantum advantages in network coding for multiple access channels. *CoRR*, abs/2304.10792, 2023. arXiv:2304.10792. Citations: § 59