



**HAL**  
open science

# Stabilization, regulation and observation of nonlinear systems

Daniele Astolfi

► **To cite this version:**

Daniele Astolfi. Stabilization, regulation and observation of nonlinear systems. Automatic. Université Claude Bernard Lyon 1, 2023. tel-04170926

**HAL Id: tel-04170926**

**<https://hal.science/tel-04170926v1>**

Submitted on 25 Jul 2023

**HAL** is a multi-disciplinary open access archive for the deposit and dissemination of scientific research documents, whether they are published or not. The documents may come from teaching and research institutions in France or abroad, or from public or private research centers.

L'archive ouverte pluridisciplinaire **HAL**, est destinée au dépôt et à la diffusion de documents scientifiques de niveau recherche, publiés ou non, émanant des établissements d'enseignement et de recherche français ou étrangers, des laboratoires publics ou privés.



# Habilitation à diriger la recherche

présentée à

**L'Université Claude Bernard Lyon 1**

par

**Daniele ASTOLFI**

---

## **Stabilization, regulation and observation of nonlinear systems**

---

Soutenue le 27 Juin 2023 devant le Jury composé de

**Alessandro ASTOLFI**  
**Jamal DAAFOUZ**  
**Daniel LIBERZON**  
**Lorenzo MARCONI**  
**Bernhard MASCHKE**  
**Laurent PRALY**  
**Sophie TARBOURIECH**

Rapporteur  
Rapporteur  
Rapporteur  
Examineur  
Président  
Examineur  
Examineur



## Preamble

---

This manuscript summarizes the work of my 10 years of research, which began during my PhD studies in 2013. Initially, my research was conducted as part of a joint Ph.D. program between the University of Bologna (Bologna, Italy) under the supervision of Lorenzo Marconi, and MinesParisTech (Paris, France) under the supervision of Laurent Praly. Subsequently, I continued my research as a post-doctoral fellow at the Centre de Recherche en Automatique de Nancy CRAN (Nancy, France) from September 2016 to August 2018, under the supervision of Romain Postoyan and Dragan Nešić. Currently, I am a CNRS junior researcher (CRCN) at the Laboratory of Automatic Control, Chemical and Pharmaceutical Engineering (LAGEPP) in Lyon, France, where I have been working since October 2018.

Throughout these years, I had the privilege of collaborating with a multitude of great people who contributed to the development of the results presented in this manuscript. I am deeply grateful to all of them for being a part of my research journey. Collaborating with each of you has been an enriching experience and undoubtedly one of the most rewarding aspects of this fantastic job.

I hope you enjoy reading the content of this manuscript,

Daniele Astolfi, July 25, 2023



## Thanks

---

*I would first like to thank Alessandro Astolfi, Jamal Daafouz, and Daniel Liberzon, who were kind enough to agree to review this manuscript. I would also like to thank Sophie Tarbouriech and Bernhard Maschke for agreeing to be members of my jury.*

*I would like to express my gratitude to Lorenzo Marconi and Laurent Praly for serving on my jury, but most of all for introducing me to the fascinating world of control theory. Without their guidance and support, I may not have pursued a career in research. I also extend my thanks to Alberto and Andrew for their valuable discussions and assistance during my earlier career years. Witnessing their work has been a continuous source of inspiration for me. I thank also Romain, Dragan, for their guidance during my post-doc and the CRAN group (Marc, Constantin, Vineeth, Pierre) for their support in my years in Nancy. Their help has been precious on numerous occasions.*

*A special thanks also goes to Giacomo, Swann, Vincent, Michelangelo, Pauline, and Luca: my closest collaborators and friends during the last years. I am also grateful to Angelo, Christophe, Lucas, Nathan, and all those I have shared discussions with and who have helped me with my works. I also want to thank my colleagues at LAGEPP (Madiha, Pascal, Ulysse, Boussad, and the others) for their friendship.*

*I don't forget my Ph.D. and post-doc students who honored me by working with me in the last 4 years: Mattia, Samuele, Elena, and Andreu. This manuscript would not have been possible without their huge work.*

*Finally, I want to thank Marie for changing my life since the day we met. Last but not least, a special thanks to my parents for always encouraging me to pursue this career, and to my sister, who is the strongest person I know in the world and always my reference point to overcome any difficulty.*



# Contents

---

<b>Summary</b>	<b>vii</b>
<b>1 Incremental stabilization of nonlinear systems</b>	<b>1</b>
1.1 Preliminaries on Riemannian analysis . . . . .	2
1.2 Incremental ISS . . . . .	3
1.2.1 Riemannian metric conditions for $\delta$ GES . . . . .	3
1.2.2 Riemannian metric conditions for $\delta$ ISS . . . . .	4
1.2.3 Euclidean metrics and LMI conditions . . . . .	6
1.3 Design of a contractive infinite-gain margin feedback . . . . .	7
1.3.1 Riemannian metric conditions . . . . .	7
1.3.2 Euclidean metrics and LMI conditions . . . . .	11
1.3.3 Observer design and nonlinear separation principle . . . . .	12
1.4 Incremental Forwarding design for cascade systems . . . . .	15
1.4.1 Riemannian metric conditions . . . . .	15
1.4.2 Euclidean metrics and LMI-based conditions . . . . .	18
1.5 Synchronization of multi-agent systems . . . . .	19
1.5.1 Preliminaries on graph theory . . . . .	19
1.5.2 Distributed feedback design . . . . .	20
1.5.3 Learning the controller via DDN . . . . .	22
1.6 Conclusions and perspectives . . . . .	24
<b>2 Stabilization of infinite dimensional systems</b>	<b>27</b>
2.1 Preliminaries on abstract operators . . . . .	28
2.2 Stability of some semi-linear systems . . . . .	29
2.2.1 Necessary and sufficient conditions . . . . .	29
2.2.2 Construction of ISS-Lyapunov functions via strictification . . . . .	30
2.2.3 An ISS-Lyapunov functional for the Korteweg-de-Vries equation . . . . .	33
2.3 Forwarding for ODE-PDE cascades . . . . .	35
2.3.1 Exponentially stable ODE and conservative PDE . . . . .	35
2.3.2 Scalar ODE coupled with a transport equation . . . . .	38
2.4 Forwarding for PDE-ODE cascades . . . . .	39
2.4.1 Exponentially Stable PDE and conservative ODE . . . . .	39
2.4.2 Korteweg-de Vries equation coupled with an integrator . . . . .	41
2.4.3 Heat equation coupled with a linear oscillator . . . . .	42
2.5 Integral action control for PDEs . . . . .	43
2.5.1 Anti-windup for linear abstract operators . . . . .	43
2.5.2 Integral action for the Korteweg-de Vries equation . . . . .	46
2.6 Conclusions and perspectives . . . . .	48



<b>3</b>	<b>Nonlinear output regulation</b>	<b>49</b>
3.1	The problem of robustness in output regulation . . . . .	51
3.1.1	Systems, limit sets and steady-state properties . . . . .	52
3.1.2	Characterization of perturbations . . . . .	54
3.1.3	Definition of a robust regulator . . . . .	55
3.2	Regulators with linear internal models . . . . .	57
3.2.1	Internal model design . . . . .	57
3.2.2	Asymptotic regulation . . . . .	57
3.2.3	Harmonic regulation . . . . .	60
3.2.4	Stabilizer design . . . . .	65
3.3	Nonlinear internal models . . . . .	71
3.3.1	Asymptotic regulation via nonlinear internal models . . . . .	71
3.3.2	$C^0$ -robust regulators are linear . . . . .	72
3.3.3	Non-asymptotic properties of finite-dimensional linear regulators . . . . .	74
3.4	Infinite-dimensional internal model regulators . . . . .	75
3.4.1	Internal model design . . . . .	75
3.4.2	Finite-dimensional approximation . . . . .	80
3.5	Conclusions and perspectives . . . . .	83
<b>4</b>	<b>Performances improvement in observers</b>	<b>85</b>
4.1	Preliminaries on hybrid systems . . . . .	86
4.2	Stubborn and dead-zone redesign . . . . .	87
4.2.1	Problem Statement . . . . .	87
4.2.2	Stubborn Redesign . . . . .	89
4.2.3	Dead-zone redesign . . . . .	91
4.3	Constrained state estimation . . . . .	93
4.3.1	Continuous-time systems . . . . .	93
4.3.2	Discrete-time and hybrid approaches . . . . .	96
4.4	Uniting observers . . . . .	98
4.4.1	Problem statement . . . . .	98
4.4.2	Assumptions . . . . .	100
4.4.3	Main result . . . . .	104
4.5	Multi-observers approach . . . . .	105
4.5.1	Problem statement . . . . .	106
4.5.2	Hybrid estimation scheme . . . . .	107
4.5.3	Main result . . . . .	110
4.6	Conclusions and perspectives . . . . .	113
<b>5</b>	<b>Conclusions and perspectives</b>	<b>115</b>
5.1	Some other contributions . . . . .	115
5.2	Perspectives . . . . .	118
	<b>Bibliography</b>	<b>121</b>
	<b>Published papers by Daniele Astolfi</b>	<b>135</b>

## Summary

---

My research focuses on control and observation problems for dynamical systems described by forced nonlinear ordinary differential equations of the form:

$$\dot{x} = f(x, u), \quad y = h(x),$$

where  $x \in \mathbb{R}^n$  is the state of the plant,  $u \in \mathbb{R}^m$  is a controlled or uncontrolled input, and  $y \in \mathbb{R}^p$  is the measured output. This generic description can be used to represent many physical models. The content of this manuscript, entitled “Stabilization, regulation and observation of nonlinear systems”, is organized in 4 chapters.

Chapter 1 describes new feedback design methodologies for incrementally stabilizing a nonlinear system. The proposed approach is based on contraction theory and the use of Riemannian metrics to make a system contractive and incrementally input-to-state stable via feedback. Two main control methodologies are developed: the design of infinite gain margin feedbacks and an incremental version of the forwarding approach. The use of infinite gain margin laws is then applied to the problem of state synchronization in networks of multi-agent systems.

Chapter 2 investigates the stabilization of systems described by the interconnection of an ordinary differential equation with an infinite-dimensional system (which may be described in terms of abstract operators over Hilbert spaces or more explicitly via some partial differential equations). This chapter is mainly motivated by the use of infinite-dimensional internal models in the context of output regulation of nonlinear systems, later developed in Chapter 3. We also provide new sufficient and necessary conditions for the stability of semi-linear operators and a constructive methodology based on observer design (inspired by the finite-dimensional literature) to design strict Lyapunov functions.

Chapter 3 is devoted to the problem of output regulation of nonlinear systems, namely the problem of tracking given references while rejecting undesired perturbations affecting the dynamics. We pursue an internal model approach and propose a new framework able to correctly characterize the notion of robustness in the output regulation context. We revisit existing design methodologies based on linear and nonlinear internal models, highlighting their robustness properties and showing that the property of asymptotic regulation cannot be generically achieved via a dynamical smooth regulator with a finite dimension. We then introduce a general framework for the design of infinite-dimensional internal model regulators for minimum-phase systems, recovering and extending the theory of repetitive control.

Chapter 4 is devoted to the general problem of improving the performance of a given nonlinear observer. To this end, we develop a number of new methodologies with a common modularity property, i.e., we do not want to redesign the observer from scratch, but rather build upon the existing one and possibly improve its performances. Furthermore, for many of these techniques, we use a hybrid redesign approach that allows for more flexibility. In this context, we first propose a new framework based on the use of saturation and dead-zone functions with variable adaptive thresholds to improve the steady-state performance in the presence of various types of

measurement noise, such as impulsive ones (e.g., outliers) or persistent ones (e.g., white noise). We then propose a general redesign framework to constrain the state of a given observer, based on the existence of a quadratic Lyapunov function and a convexity assumption. Finally, we explore a general framework to combine various observers in a hybrid fashion. We first analyze the case of combining two different observers, one possibly with local convergence properties (as in the case of extended Kalman filters) and one with global ones. Then, we consider a more general scenario in which many observers are used, using norm estimators to evaluate online which observer is performing better.

In the conclusion, I summarize a certain numbers of works that have not been presented in this manuscript. Finally, I propose several new research perspectives. The complete list of my publication is given at the end of this document in a section entitled “Published papers by Daniele Astolfi”.

Mes recherches se concentrent sur les problèmes de contrôle et d'observation pour les systèmes dynamiques décrits par des équations différentielles ordinaires non linéaires forcées de la forme :

$$\dot{x} = f(x, u), \quad y = h(x),$$

où  $x \in \mathbb{R}^n$  est l'état du système,  $u \in \mathbb{R}^m$  est une entrée contrôlée ou non contrôlée, et  $y \in \mathbb{R}^p$  est la sortie mesurée. Cette description générique peut être utilisée pour représenter de nombreux modèles physiques. Le contenu de ce manuscrit, intitulé "Stabilisation, régulation et observation de systèmes non linéaires", est organisé en 4 chapitres.

Le Chapitre 1 décrit de nouvelles méthodologies de conception de rétroaction pour stabiliser de manière incrémentale un système non linéaire. L'approche proposée est basée sur la théorie de la contraction et l'utilisation de métriques Riemanniennes pour rendre un système contractif et incrémentalement stable par rapport à l'entrée grâce à la rétroaction. Deux méthodologies de contrôle principales sont développées : la conception de rétroactions avec marge de gain infinie et une version incrémentale de l'approche de transmission. L'utilisation de lois à marge de gain infinie est ensuite appliquée au problème de synchronisation d'état dans les réseaux de systèmes multi-agents.

Le deuxième chapitre porte sur la stabilisation des systèmes décrits par l'interconnexion d'une équation différentielle ordinaire avec un système de dimension infinie (qui peut être décrit en termes d'opérateurs abstraits sur des espaces de Hilbert ou plus explicitement via certaines équations aux dérivées partielles). Ce chapitre est principalement motivé par l'utilisation de modèles internes de dimension infinie dans le contexte de régulation de sortie de systèmes non linéaires, développé plus en détail dans le chapitre 3. Nous fournissons également de nouvelles conditions suffisantes et nécessaires pour la stabilité des opérateurs semi-linéaires et une méthodologie constructive basée sur la conception d'observateurs (inspirée de la littérature en dimension finie) pour construire des fonctions de Lyapunov strictes.

Le Chapitre 3 est consacré au problème de régulation de sortie des systèmes non linéaires, à savoir le problème de suivi de références données tout en rejetant les perturbations indésirables affectant la dynamique. Nous poursuivons une approche par modèle interne et proposons un nouveau cadre capable de caractériser correctement la notion de robustesse dans le contexte de la régulation de sortie. Nous revisitons les méthodologies de conception existantes basées sur des modèles internes linéaires et non linéaires, mettant en évidence leurs propriétés de robustesse et montrant que la propriété de régulation asymptotique ne peut pas être atteinte de manière robuste via un régulateur dynamique (suffisamment régulier) avec une dimension finie. Nous introduisons ensuite un cadre général pour la conception de régulateurs de modèle interne à dimension infinie pour les systèmes à phase minimale, en récupérant et étendant la théorie du contrôle répétitif.

Le Chapitre 4 est consacré au problème d'amélioration des performances d'un observateur non linéaire donné. À cet effet, nous développons plusieurs nouvelles méthodologies ayant une

propriété de modularité commune, c'est-à-dire que nous ne voulons pas redessiner l'observateur à partir de zéro, mais plutôt nous appuyer sur celui existant et éventuellement améliorer ses performances. En outre, pour bon nombre de ces techniques, nous utilisons une approche de re-conception hybride qui permet plus de flexibilité. Dans ce contexte, nous proposons tout d'abord un nouveau cadre basé sur l'utilisation de fonctions de saturation et de zone morte avec des seuils adaptatifs variables pour améliorer la performance en régime permanent en présence de divers types de bruit de mesure, tels que les impulsions (par exemple, les valeurs aberrantes) ou les bruits persistants (par exemple, le bruit blanc). Nous proposons ensuite un cadre général de re-conception pour contraindre l'état d'un observateur donné, basé sur l'existence d'une fonction de Lyapunov quadratique et d'une hypothèse de convexité. Enfin, nous explorons un cadre général pour combiner divers observateurs de manière hybride. Nous analysons d'abord le cas de la combinaison de deux observateurs différents, l'un éventuellement avec des propriétés de convergence locale (comme dans le cas des filtres de Kalman étendus) et l'autre avec des propriétés globales. Ensuite, nous considérons un scénario plus général dans lequel de nombreux observateurs sont utilisés, en utilisant des estimateurs de norme pour évaluer en ligne lequel des observateurs fonctionne le mieux.

Dans la conclusion, je résume un certain nombre de travaux qui n'ont pas été présentés dans ce manuscrit. Enfin, je propose plusieurs nouvelles perspectives de recherche. Dans l'annexe, je résume mon Curriculum Vitæ. La liste complète de mes publications est donnée à la fin de ce document dans une section intitulée "Articles publiés par Daniele Astolfi".

## Notation

$\mathbb{R}$	Real numbers
$\mathbb{R}_{\geq 0}$	Non-negative real numbers $\mathbb{R}_{\geq} := [0, +\infty)$
$\mathbb{R}_{> 0}$	Positive real numbers, $\mathbb{R}_{> 0} := (0, +\infty)$
$\mathbb{Z}$	Integer numbers
$\mathbb{N}$	Non-negative integer numbers
$\mathbb{C}$	Complex numbers
$ x $	Standard Euclidean norm of $x \in \mathbb{R}^n$
$ x _A$	Given $A \subset \mathbb{R}^n$ and $x \in \mathbb{R}^n$ , $ x _A := \inf_{a \in A}  x - a $ denotes the distance of $x$ to $A$ .
$\mathbb{B}$	Open ball of radius 1
$A + B$	If $A, B \subset \mathbb{R}^n$ , we let $A + B := \{a + b : a \in A, b \in B\}$
$\epsilon A$	Given $\epsilon \in \mathbb{R}$ and a set $A \subset \mathbb{R}^n$ , we let $\epsilon A := \{\epsilon a : a \in A\}$ .
$(x, y)$	Given $x \in \mathbb{R}^n$ , $y \in \mathbb{R}^m$ , we set $(x, y) := (x^\top, y^\top)^\top$ .



# 1

## Incremental stabilization of nonlinear systems

---

### Contents

---

<b>1.1 Preliminaries on Riemannian analysis</b>	<b>2</b>
<b>1.2 Incremental ISS</b>	<b>3</b>
1.2.1 Riemannian metric conditions for $\delta$ GES	3
1.2.2 Riemannian metric conditions for $\delta$ ISS	4
1.2.3 Euclidean metrics and LMI conditions	6
<b>1.3 Design of a contractive infinite-gain margin feedback</b>	<b>7</b>
1.3.1 Riemannian metric conditions	7
1.3.2 Euclidean metrics and LMI conditions	11
1.3.3 Observer design and nonlinear separation principle	12
<b>1.4 Incremental Forwarding design for cascade systems</b>	<b>15</b>
1.4.1 Riemannian metric conditions	15
1.4.2 Euclidean metrics and LMI-based conditions	18
<b>1.5 Synchronization of multi-agent systems</b>	<b>19</b>
1.5.1 Preliminaries on graph theory	19
1.5.2 Distributed feedback design	20
1.5.3 Learning the controller via DDN	22
<b>1.6 Conclusions and perspectives</b>	<b>24</b>

---

This chapter focuses on the use of contraction analysis to design feedback laws ensuring the incremental stability properties of the solutions of a dynamical systems. Roughly speaking, a system is incrementally stable if any two trajectories starting from different initial conditions that are “close” remain “close” for all their time existence. If the distance between them decreases in time, then the system is incrementally asymptotically stable (see, e.g. [7, 9, 17, 18, 69, 79, 129, 152, 174, 186, 191, 217]). Although the foundations of contraction theory date back more than 60 years (see [88, 110] for a literature review on the topic), a lot of attention has been put on such an approach only in more recent years, due to its use in many control problems such as observers design [177, 219], output regulation [152], and multi-agent synchronization [8, 11, 187]. In order to characterize the incremental properties, many different tools have been proposed: incremental Lyapunov functions [17, 18]; Finsler-Lyapunov function [79, 217]; matrix measures based on both Euclidean and non-Euclidean norms [7, 69, 191]; weak-pairings [69]; and *Riemannian metrics* conditions [9, 10, 129, 186]. Very similar properties have been



also studied in the context of convergent theory [151, 152, 174] raising to conditions which are mainly equivalent to those studied in the context of Riemannian metrics (also denoted as Demidovich conditions [151]). However, few works focused on the design of a feedback making contractive a system, see, e.g. [134, 177, 220]. In this chapter, we focus on this last problem following a Riemannian contraction approach.

In Section 1.1, we recall some preliminary notions on Riemannian analysis. Then, in Section 1.2 we revisit a set of sufficient conditions to establish the contractivity property of a continuous-time nonlinear systems, in particular to guarantee a given nonlinear system to be incrementally globally exponentially stable or incrementally input-to-state stable. These conditions rely on a metric-based framework and are used then to design contractive feedback laws. Two main classes of controllers are investigated: controllers ensuring the infinite-gain margin property in an incremental context and feedbacks to incrementally stabilize systems possessing a cascade structure (also denoted in the feedforward form). The first approach investigated in Section 1.3 extends the Riccati equation and the so-called  $L_gV$  conditions in a contractive feedback. Furthermore, we provide a set of conditions based on LMI for nonlinear systems possessing a semi-linear structure with nonlinearities satisfying incrementally sector bounded or monotonic conditions. Moreover, for the same class of systems, we formulate a new separation principle for the output-feedback stabilization of a class of nonlinear systems based on the use of a contractive state-feedback law in which the state is replaced by an estimate given by a contractive observer. The second approach investigated in Section 1.4 extends the forwarding design introduced in the 90's for nonlinear systems. We introduce a modified version of the so-called forwarding modulo- $L_gV$  approach guaranteeing incremental stability of the overall closed-loop system. Finally, we conclude this chapter by using the infinite gain margin law conditions in the context of state synchronization of a network of leader-connected multi-agent systems. As a future perspective, we show that recent numerical approaches issued from deep learning can be employed to overcome the difficulties of finding an explicit solution to the feedback design which relies on the solution to a partial differential inequality.

## 1.1 Preliminaries on Riemannian analysis

Given a vector field  $f : \mathbb{R}^n \rightarrow \mathbb{R}^n$  and a 2-tensor  $P : \mathbb{R}^n \rightarrow \mathbb{R}^{n \times n}$  both  $C^1$ , we indicate with  $L_f P(x)$  the Lie derivative of the tensor  $P$  along  $f$  defined as

$$\begin{aligned} L_f P(x) &:= \mathfrak{d}_f P(x) + P(x, t) \frac{\partial f}{\partial x}(x) + \frac{\partial f}{\partial x}^\top(x) P(x), \\ \mathfrak{d}_f P(x) &:= \lim_{h \rightarrow 0} \frac{P(X(x, t+h, t)) - P(x)}{h}, \end{aligned}$$

where  $X(x, t)$  is the solution of the initial value problem

$$\frac{\partial}{\partial t} X(x, t) = f(X(x, t)), \quad X(x, 0) = x,$$

for all  $t \geq 0$ . Note that  $L_f P(x)$  can be equivalently expressed as

$$L_f P(x) = \lim_{h \rightarrow 0} \frac{(I + h \frac{\partial f}{\partial x}(x))^\top P(x + hf(x))(I + h \frac{\partial f}{\partial x}(x)) - P(x)}{h},$$

with coordinates

$$(L_f P(x, t))_{i,j} = \sum_k \left[ 2P_{ik} \frac{\partial f_k}{\partial x_j}(x) + \frac{\partial P_{ij}}{\partial x_k}(x) f_k(x) \right].$$

Given any two elements  $x_1, x_2 \in \mathbb{R}^n$ , let  $\gamma : [0, 1] \mapsto \mathbb{R}^n$  as any  $C^1$  path such that  $\gamma(0) = x_1$  and  $\gamma(1) = x_2$ . We define the length of the curve  $\gamma$  in the operator norm  $P(x)$  as

$$\ell_P(\gamma) := \int_0^1 \sqrt{\frac{d\gamma}{ds}(s)^\top P(\gamma(s)) \frac{d\gamma}{ds}(s)} ds. \quad (1.1)$$

The Riemannian distance between  $x_1$  and  $x_2$  is then defined as the infimum of the length among all the possible piecewise  $C^1$  paths  $\gamma$ , namely

$$d_P(x_1, x_2) := \inf_{\gamma} \{\ell_P(\gamma)\}.$$

For more details on Riemannian analysis, we refer to [177] and references therein or to [176].

## 1.2 Incremental ISS

### 1.2.1 Riemannian metric conditions for $\delta$ GES

We begin by considering autonomous nonlinear systems of the form

$$\dot{x} = f(x) \quad (1.2)$$

where  $f : \mathbb{R}^n \rightarrow \mathbb{R}^n$  is a  $C^2$  vector field. We denote by  $X(x_0, t)$  the solution of system (1.2) with initial condition  $x_0$  evaluated at time  $t \geq 0$ . We assume existence and uniqueness of trajectories. We define the notion of incremental stability according to the following definition.

**Definition 1.1.** *System (1.2) is incrementally globally exponentially stable ( $\delta$ GES) if there exists two strictly positive real numbers  $\lambda, k > 0$  such that*

$$|X(x_1, t) - X(x_2, t)| \leq k |x_1 - x_2| e^{-\lambda t} \quad (1.3)$$

for any couple of initial conditions  $(x_1, x_2) \in \mathbb{R}^n \times \mathbb{R}^n$  and for all  $t \geq 0$ .

Following the metric approach [10, 88, 129], a dynamical system of the form (1.2) is  $\delta$ GES if there exists a Riemannian metric for which the mapping  $t \mapsto X(x, t)$  is a contracting mapping.

**Theorem 1.1.** *Consider system (1.2) and suppose there exist a  $C^1$  matrix function  $P : \mathbb{R}^n \times \mathbb{R} \rightarrow \mathbb{R}^{n \times n}$  taking symmetric positive definite values and three real numbers  $\underline{p}, \bar{p}, \varepsilon > 0$  such that the following holds*

$$0 \prec \underline{p}I \preceq P(x) \preceq \bar{p}I, \quad (1.4a)$$

$$L_f P(x) \preceq -\varepsilon P(x), \quad (1.4b)$$

for all  $x \in \mathbb{R}^n$ . Then the system (1.2) is  $\delta$ GES.

A proof can be found in [9, 129]. A converse theorem can be found in [9, Proposition IV] in the case in which  $f$  is a globally Lipschitz vector field. Note that the lower bound in (1.4a) is required to make sure that the whole  $\mathbb{R}^n$  space endowed with the Riemannian metric  $P$  is complete. Such a condition guarantees that every geodesic (i.e. the shortest curve between  $(x_1, x_2)$ ) can be maximally extended to  $\mathbb{R}$ , see e.g. [177]. By Hopf-Rinow's Theorem (see [176, Theorem 1.1]) this implies that the metric is complete and hence that the minimum of the length of any curve  $\gamma$  connecting two point  $(x_1, x_2)$  is actually given by the length of the geodesic at any

time instant. Moreover, it guarantees that the Lyapunov function defined as  $\|\delta_x\|_P^2 := \delta_x^\top P(x)\delta_x$  associated to  $\dot{\delta}_x = \frac{\partial f}{\partial x}(x)\delta_x$ , is radially unbounded and exponentially decreasing along solutions. The upper bound in (1.4a) is introduced for solutions to be uniformly decreasing with respect to time and to correlate the Riemannian distance in  $P$  to the Euclidean one in (1.3).

We remark that the incremental stability properties are preserved by a Lipschitz global diffeomorphism with a Lipschitz inverse.

**Lemma 1.1.** *Suppose that system (1.2) is  $\delta$ GES according to Definition 1.1. Let  $\Phi : \mathbb{R}^n \rightarrow \mathbb{R}^n$  be a globally Lipschitz diffeomorphism with globally Lipschitz inverse  $\Psi$ , namely such that for some  $L_\Phi, L_\Psi > 0$ ,*

$$\Phi(\Psi(z)) = z, \quad (1.5a)$$

$$|\Phi(x') - \Phi(x'')| \leq L_\Phi |x' - x''|, \quad (1.5b)$$

$$|\Psi(z') - \Psi(z'')| \leq L_\Psi |z' - z''|, \quad (1.5c)$$

for all  $z, x', x'', z', z'' \in \mathbb{R}^n$ . Consider the change of coordinates  $x \mapsto \xi := \Phi(x)$  so that system (1.2) in the new coordinates reads

$$\dot{\xi} = \varphi(\xi) := \frac{\partial \Phi}{\partial x}(\Psi(\xi))f(\Psi(\xi)). \quad (1.6)$$

Then also system (1.6) is  $\delta$ GES.

If incremental properties are claimed using Theorem 1.1, then the construction of the metric in the new coordinates  $\xi = \varphi(x)$  can be obtained using the following result.

**Lemma 1.2.** *Consider system (1.2) and assume there exist a  $C^1$  matrix function  $P : \mathbb{R}^n \times \mathbb{R} \rightarrow \mathbb{R}^{n \times n}$  taking symmetric positive definite real values, three real numbers  $\bar{p}, \underline{p}, \lambda > 0$  such that (1.4) holds. Let  $\Phi : \mathbb{R}^n \rightarrow \mathbb{R}^n$  be a global diffeomorphism satisfying (1.5) for some  $L_\Phi, L_\Psi > 0$ . Then, there exist some strictly positive real numbers  $\bar{q}, \underline{q} > 0$  such that the system (1.6) satisfies*

$$0 \prec \underline{q}I \preceq Q(\xi) \preceq \bar{q}I, \quad (1.7a)$$

$$L_\varphi Q(\xi) \preceq -\varepsilon Q(\xi), \quad (1.7b)$$

for all  $\xi \in \mathbb{R}^n$ , for all  $t \geq t_0$ , for, where  $Q$  is given by

$$Q(\xi) := \left( \frac{\partial \Phi}{\partial x}(\Psi(\xi)) \right)^{-\top} P(\Psi(\xi)) \left( \frac{\partial \Phi}{\partial x}(\Psi(\xi)) \right)^{-1}. \quad (1.8)$$

### 1.2.2 Riemannian metric conditions for $\delta$ ISS

We study now the incremental input-to-state ( $\delta$ ISS) properties of a system of the form

$$\dot{x} = f(x) + g(x)u \quad (1.9)$$

where  $x \in \mathbb{R}^n$  is the state,  $u$  is an exogenous signal taking values in a compact set  $\mathcal{U} \subset \mathbb{R}^m$ ,  $f : \mathbb{R}^n \rightarrow \mathbb{R}^n$  and  $g : \mathbb{R}^n \rightarrow \mathbb{R}^{n \times m}$  are  $C^2$  functions. We denote by  $X(x, u, t)$  the solution of system (1.9) starting at initial condition  $x$  at time  $t$  with input  $u = u(t)$  and satisfying the initial value problem

$$\begin{aligned} X(x, u, t) &= x, \\ \frac{\partial X}{\partial t}(x, u, t) &= f(X(x, u, t)) + g(X(x, u, t))u. \end{aligned} \quad (1.10)$$

We state the following definition.

**Definition 1.2.** System (1.9) is incrementally input-to-state stable ( $\delta$ ISS) with exponential decay rate, if there exist positive real numbers  $k, \lambda, \gamma > 0$  such that

$$|X(x_1, u_1, t) - X(x_2, u_2, t)| \leq k |x_1 - x_2| e^{-\lambda t} + \gamma \sup_{s \in [0, t]} |u_1(s) - u_2(s)| \quad (1.11)$$

for all initial conditions  $x_1, x_2 \in \mathbb{R}^n$  and for all inputs  $u_1, u_2$  taking values in  $\mathcal{U} \subset \mathbb{R}^m$ , for all  $t \geq 0$ .

Similar to the result of Theorem 1.1, we aim to look for some metric-based sufficient conditions to establish an incremental ISS property. For this, we introduce the notion of Killing vector field<sup>1</sup>.

**Definition 1.3.** Given a  $C^1$  2-tensor  $P : \mathbb{R}^n \rightarrow \mathbb{R}^{n \times n}$  and a  $C^1$  matrix function  $g : \mathbb{R}^n \rightarrow \mathbb{R}^{n \times m}$ , we say that  $g$  is a Killing vector field with respect to  $P$  if

$$L_{g_i} P(x) = 0, \quad i = 1, \dots, m, \quad \forall x \in \mathbb{R}^n, \quad (1.12)$$

with  $g_i$  being the  $i$ -th column of  $g$ .

The Killing Vector property implies that distances between different trajectories generated by the vector field  $g(x)$  in the norm  $|\cdot|_{P(x)}$  are invariant. Basically, the signals that enter in the directions of the vector field  $g$  do not affect the distances, in the sense that different trajectories of the differential equation  $\dot{x} = g(x)$  have a distance (associated with the norm provided by  $P$ ) among them which is constant for any  $t \geq 0$ .

**Remark.** Note that:

- the Killing vector property is always satisfied between two constant matrices  $P$  and  $G$ ;
- for any  $C^1$  scalar vector field  $g : \mathbb{R} \rightarrow \mathbb{R}$ , then  $P(x) = g^{-2}(x)$  always satisfies the Killing vector property. Indeed

$$\begin{aligned} L_g P(x) &= \frac{\partial P}{\partial x}(x)g(x) + 2\frac{\partial g}{\partial x}(x)P(x) = \frac{\partial g^{-2}}{\partial x}(x)g(x) + 2\frac{\partial g}{\partial x}(x)g^{-2}(x) \\ &= -2\frac{g'(x)}{g^3(x)}g(x) + 2\frac{g'(x)}{g^2(x)} = 0. \end{aligned}$$

Based on the previous notion of Killing vector, we have the following result.

**Theorem 1.2.** Consider system (1.9) and suppose that  $g$  is a bounded vector field, namely there exists a real number  $\bar{g} > 0$  such that  $|g(x)| \leq \bar{g}$  for all  $x \in \mathbb{R}^n$ . If there exists a  $C^1$  matrix function  $P : \mathbb{R}^n \rightarrow \mathbb{R}^{n \times n}$  taking symmetric positive definite values and three real numbers  $\bar{p}, \underline{p}, \varepsilon > 0$  satisfying

$$0 \prec \underline{p}I \preceq P(x) \preceq \bar{p}I, \quad (1.13a)$$

$$L_f P(x) \preceq -\varepsilon P(x), \quad (1.13b)$$

$$L_g P(x) = 0, \quad (1.13c)$$

for all  $x \in \mathbb{R}^n$ , then system (1.9) is  $\delta$ ISS.

<sup>1</sup>The name ‘‘Killing vector field’’ takes the name after Wilhelm Killing, a German mathematician.

Note that differently to the definition given for instance in [17], we ask here the signal  $u$  to live in bounded compact sets. This is needed to derive the  $\delta$ ISS condition (1.11) from the metric-based conditions (1.13). Note however that the parameter  $\gamma$  doesn't depend on the compact set  $\mathcal{U}$ . Furthermore, since in the following we look for metric-based conditions to obtain the  $\delta$ ISS property (1.11), we restrict to the case of exponential convergence  $e^{-\lambda t}$ . In the more general definition considered in [17], any class- $\mathcal{KL}$  function can be considered. For instance, the previous result can be easily extended to the case in which the system (1.9) is defined as

$$\dot{x} = f(x) + g(x)\rho(u)$$

with  $\rho$  being any function for which there exists a class- $\mathcal{K}_\infty$  function  $\delta_\rho$  such that

$$|\rho(u_1) - \rho(u_2)| \leq \delta_\rho(|u_1 - u_2|).$$

In such a case,  $\gamma$  in (1.11) becomes a class- $\mathcal{K}$  function.

### 1.2.3 Euclidean metrics and LMI conditions

Consider again system (1.2) and suppose the existence of a positive definite matrix  $P$  satisfying

$$P \frac{\partial f}{\partial x}(x) + \frac{\partial f^\top}{\partial x}(x)P \preceq -\varepsilon P. \quad (1.14)$$

In this case, we talk of Euclidean metrics (in this case  $P$  is associated to an Euclidean norm) and we recover the celebrated Demidovic condition, see, e.g. [151] or [69]. Furthermore, for systems of the form

$$\dot{x} = f(x) + Bu, \quad (1.15)$$

the condition (1.14) is sufficient to establish that (1.15) is  $\delta$ ISS. This is a direct consequence of the fact that the Killing vector condition is automatically satisfied because both  $P$  and  $B$  are constant.

The Demidovic condition (1.14) is more conservative but often easier to verify than the Riemannian metric condition (1.4). Nevertheless, it still remains a partial differential inequality to be verified on an infinite number of points (i.e. for all  $x \in \mathbb{R}^n$ ). For certain classes of nonlinearities however this inequality can be transformed into a (computable) Linear Matrix Inequality. In particular, we consider *semi-linear* system of the form

$$\begin{aligned} \dot{x} &= Ax + G\varphi(\zeta) \\ \dot{\zeta} &= Hx \end{aligned} \quad (1.16)$$

with  $\zeta \in \mathbb{R}^{n_\zeta}$  and  $\varphi : \mathbb{R}^{n_\zeta} \rightarrow \mathbb{R}^{n_\varphi}$ . In this case, condition (1.14) reads

$$P \left[ A + M \frac{\partial \varphi}{\partial \zeta}(\zeta)H \right] + \left[ A + M \frac{\partial \varphi}{\partial \zeta}(\zeta)H \right]^\top P \preceq -\nu I. \quad (1.17)$$

If we further assume the function  $\varphi$  to satisfy some sector bound or monotonic conditions, the inequality (1.17) can be transformed into an LMI. To this end, we introduce the following two classes of functions.

**Assumption 1.1** (Incremental sector bound condition). *The function  $\varphi : \mathbb{R}^{n_\zeta} \rightarrow \mathbb{R}^{n_\varphi}$  satisfies*

$$\frac{\partial \varphi}{\partial \zeta}(\zeta)^\top S \left[ \frac{\partial \varphi}{\partial \zeta}(\zeta) + \Omega \right] + S^\top \left[ \frac{\partial \varphi}{\partial \zeta}(\zeta) + \Omega \right]^\top S \frac{\partial \varphi}{\partial \zeta}(\zeta) \preceq 0, \quad \forall \zeta \in \mathbb{R}^{n_\zeta},$$

for some matrix  $\Omega \in \mathbb{R}^{n_\varphi \times n_\zeta}$  and a symmetric positive definite matrix  $S \in \mathbb{R}^{n_\varphi \times n_\varphi}$ .

**Proposition 1.1.** Consider system (1.16) and suppose that  $\varphi$  satisfies Assumption 1.1. If there exist a symmetric positive definite matrix  $P \in \mathbb{R}^{n \times n}$  and a real number  $\mu > 0$  such that the following inequality holds

$$\begin{bmatrix} A^\top P + PA + \mu I & PG - H^\top \Omega^\top S \\ G^\top P + S\Omega H & -2S \end{bmatrix} \preceq 0,$$

then system (1.16) is  $\delta$ GES.

Alternatively, we can suppose that the function  $\varphi$  satisfies an incremental monotonic condition as follows.

**Assumption 1.2** (Incremental monotonic condition). The function  $\varphi : \mathbb{R}^{n_\varphi} \rightarrow \mathbb{R}^{n_\varphi}$  satisfies

$$\frac{\partial \varphi}{\partial \zeta}(\zeta) = \frac{\partial \varphi^\top}{\partial \zeta}(\zeta), \quad 0 \preceq \frac{\partial \varphi}{\partial \zeta}(\zeta) + \frac{\partial \varphi}{\partial \zeta}(\zeta)^\top \preceq \Gamma, \quad \forall \zeta \in \mathbb{R}^{n_\varphi} \quad (1.18)$$

where  $\Gamma \in \mathbb{R}^{n_\varphi \times n_\varphi}$  is a symmetric positive definite matrix.

**Proposition 1.2.** Consider system (1.16) and suppose that  $\varphi$  satisfies Assumption 1.2. If there exist a symmetric positive definite matrix  $P \in \mathbb{R}^{n \times n}$  and a real number  $\mu > 0$  such that the following inequality holds

$$\begin{pmatrix} A^\top P + PA + \mu I & PG + H^\top \\ G^\top P + H & -4\Gamma^{-1} \end{pmatrix} \preceq 0, \quad (1.19)$$

then system (1.16) is exponentially contractive.

An interesting aspect of the approach developed from Assumption 1.2 is that the condition (1.18) can be relaxed as

$$0 \preceq \frac{\partial \varphi}{\partial \zeta}(\zeta) + \frac{\partial \varphi^\top}{\partial \zeta}(\zeta), \quad \forall \zeta \in \mathbb{R}^{n_\varphi}. \quad (1.20)$$

In this case, no globally Lipschitz assumption is imposed on the mapping  $\varphi$ . In this case, the matrix inequality (1.19) reads

$$\begin{pmatrix} A^\top P + PA + \mu I & PG + H^\top \\ G^\top P + H & 0 \end{pmatrix} \preceq 0. \quad (1.21)$$

This implies that  $P = P^\top \succ 0$  has to satisfy the following (passivity-like) constraints

$$A^\top P + PA + \mu I \preceq 0, \quad H^\top = -PG.$$

Hence, no restriction on the slope of the nonlinearity has to be imposed provided that a part of the LMI is replaced by an equality constraint.

## 1.3 Design of a contractive infinite-gain margin feedback

### 1.3.1 Riemannian metric conditions

#### 1.3.1.1 Linear systems

For a linear system of the form

$$\begin{aligned} \dot{x} &= Ax + Bu \\ y &= Cx \end{aligned} \quad (1.22)$$

with state  $x \in \mathbb{R}^n$ , control input  $u \in \mathbb{R}^m$  and measured output  $y \in \mathbb{R}^p$ , we say that a feedback of the form  $u = -Ky$  possesses the infinite-gain margin property, if the matrix  $(A - \alpha BKC)$  is Hurwitz for any  $\alpha \in [1, \infty)$ . The infinite-gain margin property allows to be robust with respect to parameter uncertainties in the input matrix  $B$ . Furthermore, it plays a fundamental role in synchronization problems [124, 179]. We state the following new set of sufficient conditions.

**Lemma 1.3.** *Suppose there exist symmetric positive definite matrices  $P, Q, R$  and some matrices  $D, E$  satisfying the following equations*

$$\begin{aligned} PA + A^\top P - C^\top E^\top R^{-1} EC + Q &= 0, \\ PBD &= C^\top E^\top. \end{aligned} \tag{1.23}$$

Then, the feedback gain  $K = \frac{1}{2}DR^{-1}E$  is an infinite-gain margin static output feedback law for the triplet  $(A, B, C)$ , namely  $A - \kappa BKC$  is Hurwitz for any  $\kappa \in [1, \infty)$ .

We remark that condition (1.23) is slightly different from the one established in [121], where sufficient and necessary conditions for the existence of a static output feedback stabilizing control law are given. The conditions in [121] takes the form

$$\begin{aligned} PA + A^\top P - PBB^\top P + C^\top C + E^\top E &= 0, \\ KC - B^\top P &= -E, \end{aligned}$$

but do not necessarily have the infinite gain margin property (except for the passivity-like case  $E = 0$ ). Clearly, the proposed inequality (1.23) is in general more restrictive than [121]. Note that very similar conditions are stated in [19, Theorem 4]. Furthermore, for some particular choices of the matrices  $B, C$ , the condition (1.23) recovers the following well known results.

- In the *state-feedback form*, i.e. for systems of the form

$$\dot{x} = Ax + Bu, \quad y = x,$$

the condition (1.23) boils down to the standard ARE-based design

$$\begin{aligned} PA + A^\top P - PBR^{-1}B^\top P + Q &= 0, \\ K &= \frac{1}{2}R^{-1}B^\top P, \end{aligned} \tag{1.24}$$

with  $D = I, E = B^\top P$ . Recall that the ARE (1.24) always admits a solution if the pair  $(A, B)$  is stabilizable. Furthermore, the resulting controller is the solution to the associated optimal LQR problem minimizing the cost

$$J = \int_0^\infty x^\top(t)Qx(t) + u^\top(t)Ru(t)dt.$$

- In the *observer-feedback form*, i.e. for systems of the form

$$\dot{x} = Ax + u, \quad y = Cx,$$

the condition (1.23) recovers the ARE

$$\begin{aligned} PA + A^\top P - C^\top R^{-1}C + Q &= 0, \\ K &= \frac{1}{2}P^{-1}C^\top R^{-1}, \end{aligned} \tag{1.25}$$

with  $D = P^{-1}C^\top, E = I$ . The ARE (1.25) always admits a solution if  $(A, C)$  is detectable and it is a standard solution for the design of an observer for a system of the form  $\dot{x} = Ax, y = Cx$ .

- In the *static output-feedback form*, i.e. for MIMO square ( $m = p$ ) systems of the form

$$\dot{x} = Ax + Bu, \quad y = Cx,$$

the condition (1.23) recovers the well-known *passivity-based condition*

$$\begin{aligned} PA + A^\top P - C^\top R^{-1}C + Q &= 0 \\ PB &= C^\top, \end{aligned} \tag{1.26}$$

with  $D = I$ ,  $E = I$ , and  $K = \frac{1}{2}R^{-1}$ .

### 1.3.1.2 Nonlinear systems

Consider now a nonlinear system of the form

$$\begin{aligned} \dot{x} &= f(x) + g(x)u \\ y &= h(x) \end{aligned} \tag{1.27}$$

with state  $x \in \mathbb{R}^n$ , control input  $u \in \mathbb{R}^m$  and measured output  $y \in \mathbb{R}^p$ . The design of infinite-gain margin laws in the context of input-affine nonlinear systems of the form (1.27) has been investigated in the context of control Lyapunov function [180, Chapter 3] and arise quite naturally in the context of feedback design for passive systems, e.g. [125]. Here, we study an extension of the linear case in the context of contractive feedback laws. In particular, we state the following definition.

**Definition 1.4.** Consider system (1.27). We say that the  $C^1$  function  $\psi : \mathbb{R}^p \rightarrow \mathbb{R}^m$  is a *contractive control law with infinite gain margin for system*, if there exist a  $C^1$  matrix function  $P : \mathbb{R}^n \rightarrow \mathbb{R}^{n \times n}$ , taking symmetric positive definite values and three real numbers  $\bar{p}, \underline{p}, \varepsilon > 0$  such that, by letting

$$f_\kappa(x) := f(x) + g(x)\kappa\psi(h(x)),$$

the following holds

$$0 \preceq \underline{p}I \preceq P(x) \preceq \bar{p}I \tag{1.28a}$$

$$L_{f_\kappa}P(x) \preceq -\varepsilon P(x), \tag{1.28b}$$

for all  $x \in \mathbb{R}^n$  and all  $\kappa \geq 1$ .

For systems which are linear in the input and in the output, namely of the form

$$\begin{aligned} \dot{x} &= f(x) + Bu \\ y &= Cx, \end{aligned} \tag{1.29}$$

we have a direct extension of Lemma 1.3 which is based on the existence of a contractive Euclidean metric.

**Lemma 1.4.** Suppose there exist symmetric positive definite matrices  $P, R$  some matrices  $D, E$  and a real number  $\varepsilon > 0$  satisfying the following equations

$$\begin{aligned} P \frac{\partial f}{\partial x}(x) + \frac{\partial f^\top}{\partial x}(x)P - C^\top E^\top R^{-1}EC + \varepsilon P &\preceq 0, \\ PBD &= C^\top E^\top. \end{aligned} \tag{1.30}$$

Then, the feedback law  $\psi(x) = -\frac{1}{2}DR^{-1}Ey$  is an infinite-gain margin static output feedback law for the system (1.29).



We remark that with the previous feedback law we can also easily show (combining the results of Lemma 1.4 with Theorem 1.2) that the closed-loop system

$$\begin{aligned}\dot{x} &= f(x) + B \left( -\frac{1}{2}DR^{-1}Ey + d \right) \\ y &= Cx + w\end{aligned}$$

is  $\delta$ ISS with respect to the disturbance perturbations  $d$  satisfying the so-called *matching condition* [159, 163] and the measurement noise  $w$ .

For the more general case of systems (1.27) and a Riemannian metric, we have three result, extending *de facto* the three linear ARE-based conditions (1.24), (1.25) and (1.26). Hence, three different cases are considered. For systems in the the *state-feedback form*

$$\begin{aligned}\dot{x} &= f(x) + g(x)(u + d) \\ y &= x\end{aligned}\tag{1.31}$$

with state  $x \in \mathbb{R}^n$  control input  $u \in \mathbb{R}^m$  and perturbation  $d \in \mathbb{R}^m$  satisfying the matching condition [159, 163], we have the following result.

**Proposition 1.3.** *Consider system (1.31), and suppose there exist a  $C^1$  matrix function  $P : \mathbb{R}^n \rightarrow \mathbb{R}^n \times \mathbb{R}^n$  taking positive definite symmetric values, a function  $\alpha : \mathbb{R}^n \rightarrow \mathbb{R}^m$  and real numbers  $\underline{p}, \bar{p}, \varepsilon > 0$  such that the following hold*

$$0 \preceq \bar{p}I \preceq P(x) \preceq \underline{p}I, \tag{1.32a}$$

$$L_f P(x) - P(x)g(x)R^{-1}g^\top(x)P(x) \preceq -\varepsilon P(x), \tag{1.32b}$$

$$L_g P(x) = 0, \tag{1.32c}$$

$$\frac{\partial \alpha^\top}{\partial x}(x) = P(x)g(x), \tag{1.32d}$$

for all  $x \in \mathbb{R}^n$  and for some positive definite symmetric matrix  $R \in \mathbb{R}^{m \times m}$ . Then, the feedback law  $\psi(x) = -\frac{1}{2}R^{-1}\alpha(x)$  is a contractive control law with infinite-gain margin for system (1.31). Moreover, the closed-loop system is  $\delta$ ISS w.r.t.  $d$ .

For systems in the *observer-feedback form*

$$\begin{aligned}\dot{x} &= f(x) + u \\ y &= h(x) + w\end{aligned}\tag{1.33}$$

with state  $x \in \mathbb{R}^n$ , control input  $u \in \mathbb{R}^n$ , measured output  $y \in \mathbb{R}^p$  and perturbation  $w \in \mathbb{R}^p$  satisfying the matching condition [159, 163], we have the following conditions.

**Proposition 1.4.** *Consider system (1.33), and suppose there exist a  $C^1$  matrix function  $P : \mathbb{R}^n \rightarrow \mathbb{R}^{n \times n}$  taking positive definite symmetric values, and real numbers  $\underline{p}, \bar{p}, \varepsilon > 0$  such that the following hold*

$$0 \preceq \bar{p}I \preceq P(x) \preceq \underline{p}I, \tag{1.34a}$$

$$L_f P(x) - \frac{\partial h^\top}{\partial x}(x)R^{-1}\frac{\partial h}{\partial x}(x) \preceq -\varepsilon P(x), \tag{1.34b}$$

for all  $x \in \mathbb{R}^n$  and for some positive definite symmetric matrix  $R \in \mathbb{R}^{p \times p}$ . Moreover, suppose that the function  $\beta : \mathbb{R}^n \rightarrow \mathbb{R}^{n \times p}$  defined as

$$\beta(x) = P^{-1}(x) \frac{\partial h^\top}{\partial x}(x) \quad (1.34c)$$

is a Killing vector for  $P$  (see Definition 1.3). Then, the feedback law  $\psi(x) = -\frac{1}{2}\beta(x)R^{-1}y$  is a contractive control law with infinite-gain margin for system (1.33). Furthermore the closed-loop system is  $\delta$ ISS w.r.t.  $w$ .

Finally, for systems in the static output-feedback form

$$\begin{aligned} \dot{x} &= f(x) + g(x)(u + d) \\ y &= h(x) + w \end{aligned} \quad (1.35)$$

with state  $x \in \mathbb{R}^n$ , control input  $u \in \mathbb{R}^p$  measured output  $y \in \mathbb{R}^p$ , and perturbations/disturbances  $d, w \in \mathbb{R}^p$  satisfying the matching condition, we have then the following result.

**Proposition 1.5.** Consider system (1.35), a  $C^1$  matrix function  $P : \mathbb{R}^n \rightarrow \mathbb{R}^n \times \mathbb{R}^n$  taking positive definite symmetric values and real numbers  $\underline{p}, \bar{p}, \varepsilon > 0$  satisfying

$$0 \preceq \bar{p}I \preceq P(x) \preceq \underline{p}I, \quad (1.36a)$$

$$L_f P(x) - \frac{\partial h^\top}{\partial x}(x) R^{-1} \frac{\partial h}{\partial x}(x) \preceq -\varepsilon P(x), \quad (1.36b)$$

$$L_g P(x) = 0, \quad (1.36c)$$

$$\frac{\partial h^\top}{\partial x}(x) = P(x)g(x), \quad (1.36d)$$

for all  $x \in \mathbb{R}^n$  and for some positive definite symmetric matrix  $R \in \mathbb{R}^{p \times p}$ . Then, the feedback law  $\psi(x) = -\frac{1}{2}R^{-1}h(x)$  is a contractive control law with infinite-gain margin for system (1.35). Furthermore, the closed-loop system is  $\delta$ ISS w.r.t.  $w, d$ .

### 1.3.2 Euclidean metrics and LMI conditions

The framework proposed in Section 1.2.3 can be applied for the design of a contractive control law for controlled systems. Consider the following nonlinear continuous-time system:

$$\dot{x} = Ax + G\varphi(Hx) + Bu \quad (1.37)$$

where  $x \in \mathbb{R}^n$  is the state and  $u \in \mathbb{R}^m$  is the control input and  $\varphi : \mathbb{R}^{n_\zeta} \rightarrow \mathbb{R}^{n_\varphi}$  is a  $C^1$  function satisfying an incremental sector bound or monotonic condition as detailed below. We are now interested in designing a feedback law  $\alpha : \mathbb{R}^n \rightarrow \mathbb{R}^m$  such that the system (1.37) in closed loop with  $u = \alpha(x)$  is an exponential contraction. In our framework, we restrict ourselves to a specific feedback of the form

$$\alpha(x) = Kx + N\varphi(Hx). \quad (1.38)$$

Based on the condition (1.17), we look for gains  $K, N$  and a constant metric  $P \succ 0$  satisfying

$$P \left[ A + BK + (G + BN) \frac{\partial \varphi}{\partial \zeta}(\zeta) H \right] + \left[ A + BK + (G + BN) \frac{\partial \varphi}{\partial \zeta}(\zeta) H \right]^\top P \preceq -\mu I$$

for all  $\zeta \in \mathbb{R}^{n_\zeta}$ , and for some  $\mu > 0$ . Under the incremental sector bound condition in Assumption 1.1, the following LMI-based design can be obtained.

**Lemma 1.5.** Assume that  $\varphi$  satisfies Assumption 1.1. If there exist a symmetric positive definite matrix  $W \in \mathbb{R}^{n \times n}$ , two matrices  $Z \in \mathbb{R}^{m \times n}$ ,  $N \in \mathbb{R}^{m \times n_\varphi}$  and a real number  $\nu > 0$  such that the following LMI holds

$$\begin{pmatrix} AW + WA^\top + BZ + Z^\top B^\top & G + BN - WH^\top \Omega^\top S & W \\ (G + BN)^\top - S\Omega HW & -2S & 0 \\ W & 0 & -\nu I \end{pmatrix} \preceq 0, \quad (1.39)$$

then the closed-loop system (1.37)-(1.38) is  $\delta$ GES with  $K = ZW^{-1}$  and such a  $N$ .

In case of a nonlinear function  $\varphi$  satisfying the incremental monotonic condition in Assumption 1.2 with  $n_\varphi = n_\zeta$  then we have the following result.

**Lemma 1.6.** Assume that  $\varphi$  satisfies Assumption 1.2. If there exist a symmetric positive definite matrix  $W \in \mathbb{R}^{n \times n}$ , two matrices  $Z \in \mathbb{R}^{m \times n}$ ,  $N \in \mathbb{R}^{m \times n_\varphi}$  and a real number  $\nu > 0$  such that the following LMI holds

$$\begin{pmatrix} AW + WA^\top + BZ + Z^\top B^\top & WH^\top + (G + BN) & W \\ HW + (G + BN)^\top & -4\Gamma^{-1} & 0 \\ W & 0 & -\nu I \end{pmatrix} \preceq 0, \quad (1.40)$$

then the closed-loop system (1.37)-(1.38) is  $\delta$ GES with  $K = ZW^{-1}$  and such a  $N$ .

Similarly to the considerations at the end of Section 1.2.3, if the function  $\varphi$  satisfies the inequality (1.20), the LMI condition (1.40) is transformed into an equality constraint of the form

$$\begin{pmatrix} AW + WA^\top + BZ + Z^\top B^\top & W \\ W & -\nu I \end{pmatrix} \leq 0, \quad W > 0, \\ WH^\top = -(G + BN).$$

### 1.3.3 Observer design and nonlinear separation principle

The results of the previous section can be applied also in the context of observer design and output feedback control. Consider in particular the case in which the dynamical system (1.37) is complemented with a measured output and reads

$$\begin{aligned} \dot{x} &= Ax + Bu + G\varphi(Hx), \\ y &= Cx, \end{aligned} \quad (1.41)$$

where  $x \in \mathbb{R}^n$  is the system state,  $u \in \mathbb{R}^u$  is the control input and  $y \in \mathbb{R}^p$  is the measured output. Following [20], consider an observer of the form

$$\begin{aligned} \dot{\hat{x}} &= A\hat{x} + Bu + L(y - C\hat{x}) + G\varphi(\hat{\zeta}), \\ \hat{\zeta} &= H\hat{x} - E(y - C\hat{x}), \end{aligned} \quad (1.42)$$

where  $E, L$  are matrices in  $\mathbb{R}^{n_\zeta \times p}$  and  $\mathbb{R}^{n \times p}$  respectively. In particular, differently from many other standard design (such as Luenberger observers, Kalman like observers, high-gain observers and so on), the observer (1.42) is characterized by the presence of a correction term inside the nonlinear term. A sufficient condition to guarantee the convergence of the observer, namely, that the observer trajectories converge to the plant's trajectory is to select the matrices  $E$  and  $L$

so that to ensure that the observer defines a uniform (with respect to  $y$ ) contraction. For systems of the form (1.41) with an observer selected as (1.42), this is achieved for instance if there exists a positive definite matrix  $Q \succ 0$  such that

$$Q \left[ A - LC + G \frac{\partial \varphi}{\partial \zeta}(\zeta)(H - EC) \right] + \left[ A - LC + G \frac{\partial \varphi}{\partial \zeta}(\zeta)(H - EC) \right]^\top Q \preceq -\nu I$$

for all  $\zeta \in \mathbb{R}^{n_\zeta}$ , for some strictly positive real number  $\nu > 0$ . Indeed, under such a condition, it is easy to show the existence of positive real numbers  $(k, \lambda)$  such that

$$|x(t) - \hat{x}(t)| \leq k \exp(-\lambda t) |x(0) - \hat{x}(0)|, \quad \forall t \geq 0$$

for all initial conditions  $(x(0), \hat{x}(0)) \in \mathbb{R}^n \times \mathbb{R}^n$ . Similar to the results presented in the previous section, it is possible to give sufficient conditions in the form of LMI in order to obtain constructive conditions for the design of  $L$  and  $E$ . For instance, based on the sector bound condition in Assumption 1.1, we obtain the following result.

**Corollary 1.1.** *Assume that  $\varphi$  satisfies Assumption 1.1. If there exist a symmetric positive definite matrix  $Q \succ 0$ , two matrices  $R$  and  $E$  and a real number  $\mu > 0$  such that*

$$\begin{bmatrix} QA + A^\top - RC - C^\top R^\top + \mu I & QG - (H - EC)^\top \Omega^\top S \\ G^\top Q - S\Omega(H - EC) & -2S \end{bmatrix} \preceq 0,$$

then (1.42) is an exponentially contractive observer with  $L = Q^{-1}R$  and  $E$ .

Based on monotonic nonlinearities, the same result has been obtained in [20]. In particular, under Assumption 1.2, system (1.42) is an exponential observer for system (1.41) if there exists a solution to the following LMI

$$\begin{bmatrix} QA + A^\top Q - RC - C^\top R^\top + \mu I & (H - EC)^\top + QG \\ H - EC + G^\top Q & -4\Gamma^{-1} \end{bmatrix} \preceq 0, \quad (1.43)$$

with  $L = Q^{-1}R$ . In the following we specialize such a result for a nonlinearity satisfying (1.20).

**Lemma 1.7.** *Assume that  $\varphi$  satisfies Assumption 1.2. If there exist a symmetric positive definite matrix  $Q \in \mathbb{R}^{n \times n}$ , two matrices  $R$  and  $E$  of appropriate dimensions and a real number  $\mu > 0$  such that*

$$\begin{aligned} QA + A^\top Q - RC - C^\top R^\top + \mu I &\preceq 0 \\ (H - EC)^\top &= -QG. \end{aligned}$$

then (1.42) is an exponentially contractive observer for system (1.41) with  $L = Q^{-1}R$  and  $E$ .

As a conclusion of this section, we establish a separation principle by showing that a globally stabilizing output feedback law can be obtained by first designing a contractive state-feedback law as in Section (1.3.2), and then replacing the state by an estimate provided by a contractive observer of the form (1.42). In contrast with most of nonlinear separation principle, with the proposed conditions one may recover standard results of linear systems in which the design of gains of the state-feedback law and the observer output injection are independent, opposite to results relying on time-separation scale conditions, such as [13, 22, 196]. In our case, such a time-separation scale condition is not needed thanks to the contractivity properties. As a result,

the observer's convergence may be tuned independently of the feedback design. For instance, the observer dynamics can be selected slower than the convergence of the state-feedback law, so that to improve the overall performances in the presence of measurement noise. We recover in this sense, the standard linear separation principle result. Furthermore, it provides constructive methodologies verifying the general conditions in (??).

In order to state the last result of this section, consider system (1.41) coupled with an output feedback control law of the form

$$u = K\hat{x} + N\varphi(H\hat{x}) \quad (1.44)$$

in which the estimate  $\hat{x}$  is provided by an observer of the form (1.42). For simplicity, we consider only the case of functions  $\varphi$  satisfying the monotonic condition in Assumption 1.2, but similar results can be extended to the case of sector bound conditions of Assumption 1.1. Now, following the framework in [13] based on the notion of input-to-state stability (ISS), we recall that two different paths may be followed for the design of an output feedback law:

**Direct approach.** An ISS property is imposed on measurement error in the state feedback law to cope with the mismatch between  $x$  and  $\hat{x}$ .

**Indirect approach.** An ISS property is imposed to cope with the observer correction term.

In our context, both cases may be pursued under an extra assumption, as shown in the following.

**Theorem 1.3.** *Consider the system (1.41) and suppose Assumption 1.2 holds. Consider the feedback output law given by the observer (1.42) and control law (1.44). Suppose that the LMIs (1.40) and (1.43) are feasible for some matrices  $Q, R, E, W, Z, N$  of appropriate dimensions and any real number  $\nu, \mu > 0$ . Assume moreover that one of the following properties hold:*

- *the nonlinear term in the feedback (1.44) is zero ( $N = 0$ );*
- *the injection term inside the nonlinearity in (1.42) is zero ( $E = 0$ ).*

*Then, the origin of the closed-loop system (1.41), (1.42), (1.44) is globally exponentially stable with  $K = ZW^{-1}$ ,  $L = Q^{-1}R$ , and  $N = 0$  or  $E = 0$ .*

Note that in the general case in which  $E \neq 0$  and  $N \neq 0$  no stability results can be stated a priori. However, under additional assumptions, one might still be able to claim stability of the closed loop by addressing the problem through a small-gain analysis. In this case, the designs of the feedback and the observer cannot be made disjointed and typically a time-scale separation between these dynamics is needed.

Furthermore, we remark that the output feedback law (1.42), (1.44) doesn't ensure in general any contractivity property for the closed-loop system (1.41), (1.42), (1.44). As a consequence, if one aims at obtaining a contractive output feedback law, a more general dynamic output feedback of the form

$$u = K_1x_c + K_2y + \sum_{j=1}^m N_j\varphi(HJ_jx_c + E_jy),$$

$$\dot{x}_c = A_cx_c + \sum_{j=1}^m M_j\varphi(HJ_jx_c + E_jy)$$

needs to be considered. By rewriting the closed-loop system in the form (1.16), LMI conditions similar to those derived in Section 1.2.3 can be established in order to show contractivity of the closed-loop system.

## 1.4 Incremental Forwarding design for cascade systems

In this section we study systems which can be put in the so called forwarding-form

$$\begin{aligned}\dot{x} &= f(x) + g(x)u, \\ \dot{\eta} &= \Phi\eta + v(x),\end{aligned}\tag{1.45}$$

with  $x \in \mathbb{R}^n$ ,  $u \in \mathbb{R}^u$ , and  $\eta \in \mathbb{R}^\rho$ . Systems of the form (1.45) may arise in a large number of contexts. Some systems may already have a cascade structure (see, e.g., [158]); in other cases the  $\eta$ -dynamics may represent the dynamics of the controller, such as in output regulation with internal-model based (see Chapter 3.2.4); in some others, the  $x$ -dynamics may represent the dynamics of the actuator and  $\eta$  the state of the controlled plant. By using a certain analogy to the previous Section 1.3, where the well-known ARE is extended with a nonlinear PDE in the context of metrics, we rely in this context on the Sylvester equation and a nonlinear PDE extension. To this end, we shortly revise the linear case. This is also instrumental to the Section 2.3 where similar ideas are employed in the context of cascade systems in which one of the two dynamics is actually a PDE and the other is an ODE.

### 1.4.1 Riemannian metric conditions

#### 1.4.1.1 Linear systems

Consider a linear system of the form

$$\begin{aligned}\dot{x} &= Ax + Bu, \\ \dot{\eta} &= \Phi\eta + \Gamma x,\end{aligned}\tag{1.46}$$

with  $x \in \mathbb{R}^n$ ,  $u \in \mathbb{R}^u$ , and  $\eta \in \mathbb{R}^\rho$ . We suppose that the extended system is stabilizable<sup>2</sup>. Furthermore, we also suppose that the matrix  $A$  is Hurwitz. Evidently, this can be obtained after a preliminary state feedback. Then, we define the matrix  $M$  as the solution to the following Sylvester equation

$$MA = \Phi M + \Gamma\tag{1.47}$$

which defining a change of coordinates of the  $\eta$ -dynamics of system (1.46) as

$$\eta \mapsto z := \eta - Mx.$$

Such a change of coordinates is based on the fact that the  $x$ -dynamics is stable, and therefore we characterize the solutions of  $z$  in terms of his forcing input  $x$ . As a consequence, in the new coordinates, we obtain a decoupled system of the form

$$\begin{aligned}\dot{x} &= Ax + Bu, \\ \dot{z} &= \Phi z - MBu.\end{aligned}\tag{1.48}$$

In view of the stabilizability assumption of the original systems, the pair  $(A, B)$  and  $(\Phi, -MB)$  are both stabilizable. As a consequence, we can apply the infinite-gain margin approach introduced in Section 1.3 based on the ARE (1.24). Such an approach, however, doesn't generically provide a decoupling in term of feedback easy to extend to the nonlinear context. As a consequence, we follow here a different approach. In particular, in the case in which the  $\eta$ -dynamics

<sup>2</sup>This can be checked by following for instance the conditions in [68].

is conservative, i.e.,  $P_z \Phi + \Phi^\top P_z \preceq 0$ , we can rely on the stability of  $A$  to decouple the design of the stabilizing effects for  $x$  and  $z$ . In particular, given any  $Q_x \preceq 0$ , we can select  $P$  solution to

$$P_x A + A^\top P_x + Q_x = 0,$$

and then design a feedback gain of the form

$$K = \frac{1}{2} R^{-1} \begin{pmatrix} B^\top & -B^\top M^\top \end{pmatrix} \begin{pmatrix} P_x & 0 \\ 0 & P_z \end{pmatrix}.$$

Using the Lyapunov function

$$V(x, \eta) = x^\top P_x x + (\eta - Mx)^\top P_z (\eta - Mx)$$

one obtains the LMI

$$\begin{pmatrix} -Q & 0 \\ 0 & 0 \end{pmatrix} - \begin{pmatrix} P_x & 0 \\ 0 & P_z \end{pmatrix} \begin{pmatrix} B \\ -MB \end{pmatrix} R^{-1} \begin{pmatrix} B^\top & -B^\top M^\top \end{pmatrix} \begin{pmatrix} P_x & 0 \\ 0 & P_z \end{pmatrix} \preceq 0$$

showing stability of the  $(x, z)$ -dynamics. Asymptotic stability can be further established using standard zero-state detectability arguments (ensured by the stabilizability of the original system). Note that selecting  $R$  with a block-diagonal structure  $R = \text{blkdiag}(R_x, R_z)$ , we obtain, in the original  $(x, \eta)$ -coordinates, the ‘‘classical’’ forwarding control feedback

$$u = -\frac{1}{2} R_x^{-1} B^\top P_x x + \frac{1}{2} R_z^{-1} B^\top M^\top P_z (\eta - Mx),$$

which is also an infinite-gain margin law. Note that if we select  $R_x^{-1} = 0$ , the resulting feedback

$$u = \frac{1}{2} R_z^{-1} B^\top M^\top P_z (\eta - Mx)$$

has still the infinite-gain margin property. In this case one needs to rescale the Lyapunov function according to the gain  $R_z$ . Furthermore, in view of the stability properties of  $A$ , it is also possible to make a feedback which doesn’t depend on  $x$  but only on  $\eta$ . In particular, one can select

$$u = \varepsilon B^\top M^\top P_z \eta$$

with  $\varepsilon > 0$  being in this case a parameter sufficiently small. In this case we obtain a small-gain feedback approach which is also employed in the so-called ‘‘nested-saturation’’ approach [197]. Following a similar Lyapunov analysis it is possible to obtain a direct extension to nonlinear systems of the form (1.45), see, e.g. [141, 158]. In the next section we show an extension in the contractive framework.

### 1.4.1.2 Nonlinear systems

Consider again the nonlinear system

$$\begin{aligned} \dot{x} &= f(x) + g(x)(u + d), \\ \dot{\eta} &= \Phi \eta + v(x), \end{aligned} \tag{1.49}$$

with state variables  $x \in \mathbb{R}^n$ ,  $\eta \in \mathbb{R}^\rho$ , control input  $u \in \mathbb{R}^u$ , and a perturbation  $d \in \mathbb{R}^u$  satisfying the matching condition. We aim at designing a contracting feedback law so that to make the closed-loop system (1.49)  $\delta$ GES and  $\delta$ ISS with respect to the perturbation  $d$ . To this end, we suppose that the  $x$ -dynamics has been already incrementally stabilized (this is indeed a necessary condition in order to obtain the cascade  $\delta$ GES). The following assumption is therefore stated.

**Assumption 1.3.** Consider system (1.49). There exist a  $C^1$  matrix function  $P : \mathbb{R}^n \rightarrow \mathbb{R}^{n \times n}$  taking symmetric positive values and three positive real numbers  $\underline{p}, \bar{p}, \varepsilon$  such that the following holds for all  $x \in \mathbb{R}^n$

$$\begin{aligned} 0 &\preceq \underline{p}I \preceq P(x) \preceq \bar{p}I, \\ L_f P(x) &\preceq -\varepsilon P, \\ L_g P(x) &= 0. \end{aligned}$$

Furthermore, we suppose that the  $\eta$ -dynamics is marginally stable.

**Assumption 1.4.** There exists a symmetric positive definite matrix  $Q = Q^\top \succ 0$  such that  $Q\Phi + \Phi^\top Q \preceq 0$ .

Following the linear case, we define a function  $M : \mathbb{R}^n \rightarrow \mathbb{R}^\rho$  solution to the following PDE

$$\frac{\partial M}{\partial x} f(x) = \Phi M(x) + v(x) \quad (1.50)$$

which extends the Sylvester equation (1.47). Existence of a solution to (1.50) is guaranteed if the equilibrium of  $\dot{x} = f(x)$  is globally asymptotically stable and locally exponentially stable. A detailed discussion is given in [141]. Under Assumption 1.3, such a function  $M$  always exists. However, in order to provide more degrees of freedom for the feedback design so that to obtain less stringent condition, we consider here a modified version of the PDE equation (1.50). In particular, we introduce a function  $\bar{M} : \mathbb{R}^n \rightarrow \mathbb{R}^\rho$  solution to the following modified PDE

$$\frac{\partial \bar{M}}{\partial x} f(x) = \Phi \bar{M}(x) + v(x) + \Delta(x) \quad (1.51)$$

where  $\Delta$  is an additional degree of freedom. The functions  $\bar{M}$  and  $\Delta$  needs to be chosen according to the following assumption.

**Assumption 1.5.** There exist three  $C^1$  functions  $\bar{M} : \mathbb{R}^n \rightarrow \mathbb{R}^\rho$ ,  $\Delta : \mathbb{R}^n \rightarrow \mathbb{R}^\rho$  and  $\beta : \mathbb{R}^n \rightarrow \mathbb{R}^m$ , a matrix  $G$  and a real number  $\varepsilon > 0$  such that, for all  $x \in \mathbb{R}^n$ , the functions  $\bar{M}$  and  $\Delta$  are solution to (1.51), the pair  $(\Phi, (QG)^\top)$  is detectable and moreover

$$L_g \bar{M}(x) = G, \quad (1.52a)$$

$$G \frac{\partial \beta}{\partial x}(x) = -\frac{\partial \Delta}{\partial x}(x), \quad (1.52b)$$

$$L_f P(x) + P(x)g(x) \frac{\partial \beta}{\partial x}(x) + \frac{\partial \beta^\top}{\partial x}(x)g^\top(x)P(x) \preceq -\varepsilon I. \quad (1.52c)$$

Under the previous assumptions, we have the following result.

**Theorem 1.4.** Consider system (1.49) and let Assumptions 1.3, 1.4, 1.5 hold. Moreover assume that there exists  $L_M \geq 0$  such that

$$\left| \frac{\partial \bar{M}}{\partial x}(x) \right| \leq L_M \quad \forall x \in \mathbb{R}^n. \quad (1.53)$$

Then, for any gain  $\kappa > 0$ , the system (1.49) in closed-loop with the control law

$$u = \kappa G^\top Q^\top (\eta - \bar{M}(x)) + \beta(x) \quad (1.54)$$

is  $\delta$ GES and  $\delta$ ISS with respect to  $d$ .



The proof of Theorem 1.4 is based on the construction of a metric for the extended system  $(x, \eta)$  which satisfies the conditions of Theorem 1.1 and 1.2. Similarly to the linear case, the metric is constructed in the modified coordinates

$$(x, \eta) \mapsto (x, z) := (x, \eta - \bar{M}(x)).$$

The Lipschitz condition (1.53) is then required to satisfy the conditions of Lemma 1.2, which ensures the preservation of the contraction properties via a nonlinear change of coordinates.

It can be noticed also that the resulting feedback (1.54) is not exactly an infinite gain margin law because the parameter  $\kappa$  multiplies only the first term, but not the second. Indeed, such a second term  $\beta$  is needed to compensate the term  $\Delta$  introduced by the mismatch between the function  $M$  satisfying the exact forwarding equation (1.50) and the actually implemented function  $\bar{M}$  which satisfies (1.51). Such a term  $\beta$  is compensated by the stability margin property of the  $x$ -dynamics as ensured in (1.52c).

Finally, we note that the condition (1.52a) asks for the term  $L_g \bar{M}$ , i.e. the term multiplying the control action  $u$  in the modified coordinates to be constant. This is needed because the metric in the  $(x, z)$ -coordinates above defined is constant with respect to  $z$ , allowing the Killing vector property to be satisfied.

When considering  $\bar{M} = M$ , then the function  $\Delta = 0$  and  $\beta = 0$ . In such a case, we recover a pure extension of the linear forwarding approach presented in the previous section. The introduction of the extra degree of freedom to choose the function  $\bar{M}$  are motivated by the condition (1.52a) which may be very stringent in some cases. Theorem 1.4 is inspired and extends the forwarding modulo  $L_g V$  approach introduced in [158].

### 1.4.2 Euclidean metrics and LMI-based conditions

In this section we specialize our previous results to the following class of Lipschitz systems of the form

$$\begin{aligned} \dot{x} &= Ax + Bu + \Phi \vartheta(Hx) + d_1 \\ \dot{\eta} &= Cx + D\vartheta(Hx) + d_2 \end{aligned} \quad (1.55)$$

where  $\vartheta$  is a  $C^1$  Lipschitz function with Lipschitz constant  $L_\vartheta$ , namely

$$|\vartheta(y) - \vartheta(y')| \leq L_\vartheta |y - y'|, \quad \forall y, y',$$

and  $d_1, d_2$  are two perturbations. We suppose that the following assumption holds.

**Assumption 1.6.** *There exist a constant symmetric positive definite matrix  $P$  and a real number  $\lambda_0 > 0$  satisfying the inequality*

$$PA + A^\top P + P\Phi \frac{\partial \vartheta}{\partial x}(x)H + H^\top \frac{\partial \vartheta}{\partial x}(x)\Phi^\top P \preceq -2\lambda_0 I \quad \forall x \in \mathbb{R}^n.$$

Such an assumption is a particular case of Assumption 1.3 in which we considered a constant Euclidean metric  $P$ , similar to what is done in Section 1.2.3. In order to provide a forwarding-based design, we follow the previous section. In particular, instead of looking for the exact solution  $M$  of the PDE (1.51), we look for an approximation  $\bar{M}$  that is obtained by considering only the linear terms of (1.55). Let us define the following functions and matrices

$$\begin{aligned} \bar{M}(x) &= CA^{-1}x, \\ \Lambda &:= CA^{-1}B, \\ N(x) &:= (CA^{-1}D - \Phi)\vartheta(Hx), \\ \Psi &= \Lambda^\top (\Lambda \Lambda^\top)^{-1}. \end{aligned}$$

We have the following result.

**Theorem 1.5.** *Consider system (1.55) and suppose Assumption 1.6 holds. Then, the following holds.*

- If  $\Lambda$  is full rank and the inequality

$$PB\Psi(CA^{-1}D - \Phi)H + (\Psi(CA^{-1}D - \Phi)H)^\top B^\top P \preceq \frac{2(\lambda_0 - \lambda_1)}{L_\vartheta} I, \quad (1.56)$$

is satisfied for some  $\lambda_1 > 0$ , system (1.55) in closed loop with

$$u = \kappa\Psi(\eta - CA^{-1}x) - \Psi(CA^{-1}D - \Phi)\vartheta(Hx)$$

is  $\delta$ ISS with respect to  $d_1, d_2$  for any  $\kappa > 0$ .

- If the inequality

$$\left(\alpha PB\Psi - \frac{L_\vartheta}{\alpha}(CA^{-1}D - \Phi)H\right)\left(\alpha PB\Psi - \frac{L_\vartheta}{\alpha}(CA^{-1}D - \Phi)H\right)^\top \preceq 2(\lambda_0 - \lambda_2)I$$

is satisfied for some  $\lambda_2, \alpha > 0$ , then system (1.55) in closed loop with

$$u = \kappa\Psi\eta$$

is  $\delta$ ISS with respect to  $d_1, d_2$  for  $\kappa > 0$  sufficiently small.

Note that inequality (1.56) is verified with  $\lambda_1 = \lambda_0$  when  $CA^{-1}D = \Phi$  or for some  $\lambda_1 < \lambda_0$  when  $L_\vartheta$  is sufficiently small compared to  $\lambda_0$ .

## 1.5 Synchronization of multi-agent systems

As a last section of this chapter, we show how the use of infinite-gain margin laws can be used in the context of synchronization of multi-agent systems.

### 1.5.1 Preliminaries on graph theory

A communication graph is described by a triplet  $\mathcal{G} = \{\mathcal{V}, \mathcal{E}, \mathcal{A}\}$  in which  $\mathcal{V} = \{v_1, v_2, \dots, v_N\}$  is a set of  $N \subset \mathbb{N}$  vertexes (or nodes),  $\mathcal{E} \subset \mathcal{V} \times \mathcal{V}$  is the set of edges  $e_{jk}$  that models the interconnection between the vertexes with the flow of information from vertex  $j$  to vertex  $k$  weighted by the  $(k, j)$ -th entry  $a_{kj} \geq 0$  of the adjacency matrix  $\mathcal{A} \in \mathbb{R}^{N \times N}$ . We denote by  $\mathcal{L} \in \mathbb{R}^{N \times N}$  the Laplacian matrix of the graph, defined as

$$\ell_{kj} = -a_{kj} \quad \text{for } j \neq k, \quad \ell_{kj} = \sum_{i=1}^N a_{ki} \quad \text{for } k = j,$$

where  $\ell_{j,k}$  is the  $(j, k)$ -th entry of  $\mathcal{L}$ . We denote with  $\mathcal{N}_i$  the set of in-neighbors of node  $i$ , i.e. the set  $\mathcal{N}_i := \{j \in \{1, \dots, N\} | e_{ji} \in \mathcal{E}\}$ . A time-invariant graph is said to be *weakly connected* if and only if  $\mathcal{L}$  has only one trivial eigenvalue  $\lambda_1(\mathcal{L}) = 0$  and all other eigenvalues  $\lambda_2(\mathcal{L}), \dots, \lambda_N(\mathcal{L}) \in \mathbb{C}$  have strictly positive real parts (see [106, Theorem 5.1]). We consider here *leader-connected* undirected graphs. With leader-connected, we mean that we assume the existence of a *leader* (i.e. the graph contains at least one spanning tree with the leader as a root).

The leader is labeled (without loss of generality) as node 1 and has a set of in-neighbors that is the empty set, i.e.  $\mathcal{N}_1 = \emptyset$ . In other words, no node in the network can send information to node 1. We also assume the network to be *undirected*, meaning that we assume communication links to be bi-directional (i.e.  $e_{ij} = e_{ji}$  for every  $i, j = 2, \dots, N$ ), except, of course, to the edges that nodes in the network share with the leader. By considering such a graph structure, the following property is proved in [89].

**Lemma 1.8.** *Suppose the graph  $\mathcal{G} = \{\mathcal{V}, \mathcal{E}, \mathcal{A}\}$  is undirected and leader-connected. Then the Laplacian  $\mathcal{L}$  can be partitioned as*

$$\mathcal{L} = \begin{pmatrix} 0 & 0 \\ \mathcal{L}_{21} & \mathcal{L}_{22} \end{pmatrix}$$

Moreover, there exists a strictly positive real number  $\mu > 0$  such that  $\mathcal{L}_{22} \succeq \mu I$

### 1.5.2 Distributed feedback design

Consider now network of  $N$  agents. Without loss of generality we label the leader as node 1 and we suppose that its dynamics is defined by

$$\dot{x}_1 = f(x_1), \quad x_1 \in \mathbb{R}^n, \quad (1.57a)$$

and we suppose that it satisfies the following assumption.

**Assumption 1.7.** *The graph  $\mathcal{G} = \{\mathcal{V}, \mathcal{E}, \mathcal{A}\}$  is undirected and leader-connected. Moreover, for any initial condition  $x_1^o \in \mathbb{R}^n$  the corresponding trajectory of (1.57a) exists for all  $t \geq 0$ .*

The dynamics of the other  $N - 1$  nodes in the network are described as

$$\dot{x}_i = f(x_i) + g(x_i)u_i, \quad i = 2, \dots, N. \quad (1.57b)$$

where  $x_i \in \mathbb{R}^n$  is the state of node  $i$  and  $u_i \in \mathbb{R}^m$  is the control action on node  $i$ . We suppose that  $f, g$  are  $C^2$  functions and we denote the state of the entire network as

$$\mathbf{x} := \text{col}(x_1, \dots, x_N) \in \mathbb{R}^{Nn}. \quad (1.58)$$

Our synchronization objective is to design a nonlinear diffusive coupling, namely a distributed feedback control law of the form

$$u_i = \sum_{j \in \mathcal{N}_i} a_{ij} [\varphi(x_i) - \varphi(x_j)] = - \sum_{j=1}^N \ell_{ij} \varphi(x_j) \quad (1.59)$$

for all  $i = 2, \dots, N$ , for some  $C^1$  function  $\varphi : \mathbb{R}^n \rightarrow \mathbb{R}^m$ , that stabilizes the dynamics (1.57) on the so-called *leader-synchronization manifold*  $\mathcal{D}$  defined as

$$\mathcal{D} := \{\mathbf{x} \in \mathbb{R}^{Nn} \mid x_i = x_1, \text{ for all } i \in \{1, \dots, N\}\}, \quad (1.60)$$

where the states of all the agents of the network agree with the leader. In particular, we desire that the solutions  $\mathbf{X}(\mathbf{x}^o, t) = (X_1(x_1^o, t), \dots, X_N(x_N^o, t))$  to the closed-loop system

$$\begin{aligned} \dot{x}_1 &= f(x_1, t) \\ \dot{x}_i &= f(x_i) - g(x_i) \sum_{j \in \mathcal{N}_i} \ell_{ij} \varphi(x_j), \quad i = 2, \dots, N. \end{aligned} \quad (1.61)$$

converge to the manifold  $\mathcal{D}$ . By construction, the  $i$ -th agent uses only the information  $x_j$  of its neighborhoods  $j \in \mathcal{N}_i$  and its own local information  $x_i$ . Furthermore, the control action  $u_i$  is equal to zero on the synchronization manifold. In other words, when consensus is achieved, no correction term is needed for each individual agent. As a consequence, stabilizing all the agents on a desired equilibrium point is generally not a valid solution in such a framework.

Based on the results of Section 1.3.1.2 and in particular on Proposition 1.3, we state the following assumptions.

**Assumption 1.8.** *There exist a  $C^1$  matrix function  $P : \mathbb{R}^n \times \mathbb{R} \rightarrow \mathbb{R}^{n \times n}$  taking symmetric positive definite values and real numbers  $\underline{p}, \bar{p}, \rho, \lambda > 0$  such that the following holds for all  $x, \in \mathbb{R}^n$*

$$\begin{aligned} L_f P(x) - \rho P(x) g(x) g(x)^\top P(x) &\preceq -2\lambda P(x), \\ \underline{p}I &\preceq P(x) \preceq \bar{p}I. \end{aligned} \quad (1.62)$$

**Assumption 1.9.** *The matrix function  $g$  satisfies the Killing vector field property with respect to  $P$  (see Definition 1.3), namely*

$$L_g P(x) = 0, \quad \forall x \in \mathbb{R}^n. \quad (1.63)$$

**Assumption 1.10.** *The vector field  $Pg$  satisfies an integrability condition in the sense that, denoting  $g = [g_1 \dots g_m]$ , there exists a  $C^2$  function  $\alpha = (\alpha_1, \dots, \alpha_m)$ ,  $\alpha_\iota : \mathbb{R}^n \times \mathbb{R} \mapsto \mathbb{R}$  for  $\iota = 1, \dots, m$ , satisfying*

$$\frac{\partial \alpha_\iota}{\partial x}(x) = g_\iota(x)^\top P(x), \quad \forall x \in \mathbb{R}^n. \quad (1.64)$$

Based on the previous assumptions, a feedback law solving the synchronization law is established by the following theorem.

**Theorem 1.6.** *Consider a network  $G = \{\mathcal{V}, \mathcal{E}, \mathcal{A}\}$  of agents (1.57) and let Assumptions 1.7 to 1.10 hold. Then, for any  $\kappa \geq \frac{\rho}{2\mu}$ , with  $\mu$  given by Lemma 1.8, the distributed state-feedback control law (1.59) with*

$$\varphi(x) = \kappa \alpha(x), \quad (1.65)$$

and  $\alpha$  satisfying (1.64), solves the global synchronization problem for the network of agents given in (1.57), namely, there exists  $k > 0$  such that for all  $(\mathbf{x}^\circ, t_0)$  in  $\mathbb{R}^{Nn} \times \mathbb{R}$  solutions of the closed-loop system (1.61) are defined for all  $t \geq 0$  and moreover

$$|\mathbf{X}(\mathbf{x}^\circ, t)|_{\mathcal{D}} \leq k \exp(-\lambda t) |\mathbf{x}^\circ|_{\mathcal{D}}, \quad \forall t \geq 0. \quad (1.66)$$

The main limitation of the approach presented in the previous theorem is the complexity of finding a metric  $P$  solving (1.62) and, at the same time, satisfying the Killing vector field property in (1.63) and the integrability condition in (1.64). As a consequence, we provide now a practical solution to such limitations showing that synchronization may still be obtained when relaxing such assumptions. Note that the type of result is different in the two contexts. Indeed, global result can still be achieved in case of an approximation of the integrability condition, provided the control gain is not selected too large. However, only semi-global results can be obtained when relaxing the Killing vector assumption. Instead of Assumption 1.10, consider the following one.

**Assumption 1.11.** *There exist a  $C^2$  function  $\alpha : \mathbb{R}^n \mapsto \mathbb{R}^m$  and a scalar  $\varepsilon > 0$  such that, for  $\iota = 1, \dots, m$ , the following holds*

$$\left| \frac{\partial \alpha_\iota}{\partial x}(x) - g_\iota(x)^\top P(x) \right| \leq \varepsilon, \quad \forall x \in \mathbb{R}^n.$$

Based on the previous approximate integrability conditions, we have then the following result.

**Theorem 1.7.** Consider a network  $G = \{\mathcal{V}, \mathcal{E}, \mathcal{A}\}$  of agents (1.57) and let Assumptions 1.7, 1.8, 1.9 and 1.11 hold. Assume moreover that there exists a real number  $\bar{g} > 0$  such that  $|g_\iota(x)| \leq \bar{g}$  for all  $x$  in  $\mathbb{R}^n$  and  $\iota = 1, \dots, m$ . Let  $\mu$  be given by Lemma 1.8 and let  $\bar{L} = \max_{ij} |\ell_{ij}|$  where  $(\ell_{ij})$  is the Laplacian matrix associated to the graph. Then, if  $\varepsilon$  in Assumption 1.11 satisfies  $\varepsilon \in [0, \varepsilon^*)$  with

$$\varepsilon^* = \frac{\lambda \mu \underline{p}}{\rho N \bar{L} m \bar{p} \bar{g}},$$

then there exists  $\kappa^*$  such that for any  $\kappa \in [\frac{\rho}{2\mu}, \kappa^*)$ , the distributed state-feedback control law (1.59), (1.65) solves the global synchronization problem for the closed-loop system (1.61).

When the equality constraint in Assumption 1.9 is replaced by an approximation, the global synchronization may be lost. However, it is shown in the following theorem that provided  $|L_g P|$  is small enough, a semi-global result can be obtained.

**Theorem 1.8.** Consider a network  $G = \{\mathcal{V}, \mathcal{E}, \mathcal{A}\}$  of systems (1.57). Suppose Assumption 1.7, 1.8, and 1.10 hold. Let  $\kappa \geq \frac{\rho}{\mu}$  be fixed. Assume  $|g(x)| \leq \bar{g}$  for all  $x$  in  $\mathbb{R}^n$ . Then, for each  $\bar{x} > 0$  there exist  $k, \varepsilon > 0$  such that, if the following holds

$$|L_{g_\iota} P(x)| \leq \varepsilon, \quad \forall (x, \iota) \in \mathbb{R}^n \times \{1, \dots, m\}, \quad (1.67)$$

then, for all  $\mathbf{x}^\circ$  in  $\mathbb{R}^{Nn}$  such that  $\|\mathbf{x}^\circ\|_{\mathcal{D}} \leq \bar{x}$ , the solution of (1.61) with the distributed state-feedback control law (1.59), (1.65) is defined for all  $t \geq 0$  and satisfies

$$\|\mathbf{X}(\mathbf{x}^\circ, t)\|_{\mathcal{D}} \leq k \exp\left(-\frac{\lambda}{3} t\right) \|\mathbf{x}^\circ\|_{\mathcal{D}}, \quad \forall t \geq 0. \quad (1.68)$$

### 1.5.3 Learning the controller via DDN

As mentioned in the previous section, a drawback of the proposed approach lies in the fact that metrics may not be easy to find in the Riemannian scenario. Moreover, even when a metric has been found, designing a control law satisfying the integrability condition (1.64) may not be straightforward. One way to overcome such difficulties is to leverage Theorem 1.7 and Theorem 1.8 and rely on Machine Learning tools to obtain approximate solutions. In what follows, we combine the proposed control design with Deep Learning tools. In recent years, Deep Neural Networks (DNNs) turned out to be effective tools for solving complex differential equations, see, e.g., [50, 164]. As a matter of fact, multiple works began mixing learning tools and control. Such a combined framework tackles the complexity of computing control theoretic exact solutions by exploiting deep approximators. e.g., [D68], [109, 154]. Hence, the idea is to set up and approximately solve an optimization problem aimed at circumventing the need for an analytic metric. Once a suitable metric has been found via a first DNN, we train a second one to satisfy the integrability condition. To this end, we construct a neural metric as

$$P(x, \theta') = \begin{pmatrix} P_1(x, \theta') & \cdots & P_n(x, \theta') \\ \vdots & \ddots & \vdots \\ P_n(x, \theta') & \cdots & P_p(x, \theta') \end{pmatrix},$$

where  $p = \frac{n(n+1)}{2}$  is the total number of entries to be learned,  $\varrho = (P_1(x, \theta'), \dots, P_p(x, \theta'))$  is the output vector of the neural network  $\text{DNN}_P : \mathbb{R}^n \times \mathbb{R}^{n_{\theta'}} \mapsto \mathbb{R}^p$  and  $\theta' \in \mathbb{R}^{n_{\theta'}}$  is the vector of  $\text{DNN}_P$

parameters. To train the  $\text{DNN}_P$  parameters, we rely on Theorem 1.7 to relax the existence of a primitive for  $g(x)^\top P(x, \theta')$  and on Theorem 1.8 to loosen the constraint posed by the Killing vector field property (1.63). We set up an optimization problem asking for the minimization of the following cost function

$$J_P(x, \theta') = \sum_{i=1}^4 w_i J_i(x, \theta'), \quad J_i(x, \theta') = \ln(\max(\Re\{\lambda_\Psi(\Psi_i)\}, 0) + 1), \quad (1.69)$$

being  $w = (w_1, \dots, w_4)$  a vector of (positive) scalar weights and  $\lambda_\Psi$  being the maximum eigenvalue and  $\Psi_i$  defined as

$$\begin{aligned} \Psi_1 &= L_f P(x, \theta') - \rho P(x, \theta') g(x) g^\top(x) P(x, \theta') + \varepsilon I, & \Psi_2 &= L_g P(x, \theta') - \epsilon I, \\ \Psi_3 &= -L_g P(x, \theta') - \epsilon I, & \Psi_4 &= -P(x, \theta') + p I, \end{aligned}$$

where  $\rho, \epsilon, \underline{p} > 0$  are positive scalars with  $\varepsilon > \epsilon$  and where  $\Re\{\lambda\}$  is the real part of the complex number  $\lambda \in \mathbb{C}$ . Note that each cost  $J_i$  serves the purpose of satisfying a particular condition for the neural metric. While  $J_1$  provides a positive cost if the contraction condition (1.62) is not satisfied,  $J_2$  and  $J_3$  encourage the boundedness of  $L_g P$ , thus relaxing the Killing vector condition (1.63), and  $J_4$  steers the solution towards positive definite matrices, see (1.62). Note that the upperbound is always satisfied as we optimize our algorithm in a compact set  $X$ . The natural logarithm is used as a regularization term between costs  $J_i$ . It allows the rescaling of widely different costs to similar values and a more precise selection of their importance through the weight vector  $w$ . In parallel to the  $\text{DNN}_P$ , we train a parameter estimator outputting the values of  $\rho, \varepsilon, \epsilon, \underline{p}$ . The estimator and  $\text{DNN}_P$  work together, trying to minimize (1.69). Note that if the cost reaches 0, all the contraction conditions are satisfied for the dataset and the learned estimator outputs, hence learning can be stopped. The second step is to find a suitable law satisfying the as best as possible the integrability condition (1.64). We train the parameters  $\theta'' \in \mathbb{R}^{n_{\theta''}}$  of the second network  $\text{DNN}_\alpha : \mathbb{R}^n \times \mathbb{R}^{n_{\theta''}} \mapsto \mathbb{R}^m$  such that

$$J_\alpha(x, \theta'') = \left| \frac{\partial \text{DNN}_\alpha}{\partial x}(x, \theta'') - g(x)^\top P(x, \theta') \right|^2 \quad (1.70)$$

is minimized. The full learning procedure is summarized as follows.

---

**Algorithm 1** DNN-based controller learning
 

---

- 1: Input: Dataset of  $(x, f(x), g(x), \frac{\partial f}{\partial x}(x), \frac{\partial g}{\partial x}(x))$ ,  
 $\text{DNN}_P, \text{DNN}_\alpha$ ;
  - 2: **while**  $J_P(x, \theta') \neq 0$  **do**
  - 3:   Train  $\text{DNN}_P$  and the estimator with (1.69);
  - 4: **end while**
  - 5: Train the  $\text{DNN}_\alpha$  with (1.70);
  - 6: Set the distributed law  $u_i = -\kappa \sum_{j=1}^N \ell_{ij} \text{DNN}_\alpha(x_j, \theta'')$ .
- 

Clearly, the DNNs can be trained only on a dataset  $\mathbb{D}$  of finite size. Yet, DNNs are typically Lipschitz-continuous functions. Hence, similarly to [212, Section IV], we provide a verification tool via the following proposition, to assess the satisfaction of contraction conditions over compact sets once the training is over.

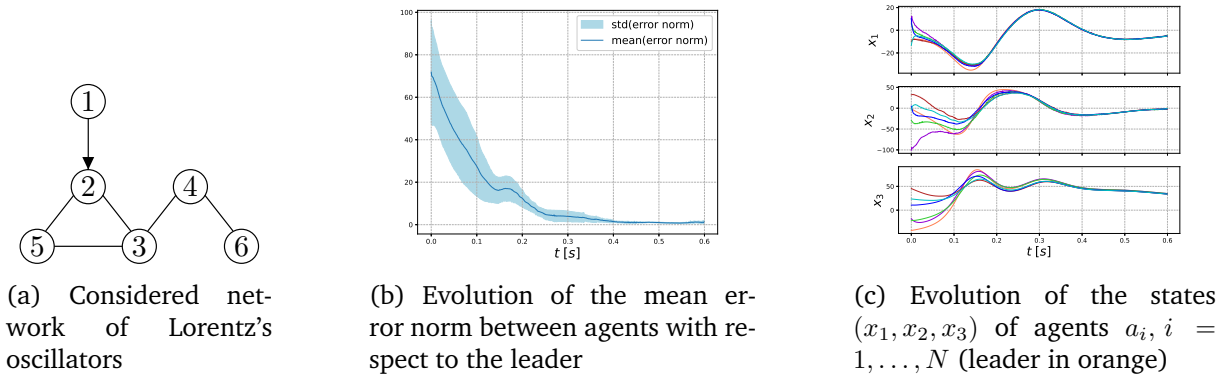

Figure 1.1: Synchronization of Lorentz's oscillators

**Proposition 1.6.** Let  $\mathcal{S} \subset \mathbb{R}^n$  be an arbitrary compact set and  $\mathbb{D} \subset \mathbb{R}^n$  a set with a finite number of elements and let  $r > 0$  be such that

$$\mathcal{S} \subseteq \bigcup_{x_i \in \mathbb{D}} \mathcal{B}(x_i, r), \quad \mathcal{B}(x_i, r) := \{x \in \mathbb{R}^n : |x - x_i| < r\}.$$

Let  $M : \mathbb{R}^n \rightarrow \mathbb{R}^{n \times n}$  be a Lipschitz-continuous matrix-valued function, with Lipschitz constant  $L_M$ , taking symmetric values and such that  $M(x_i) \preceq -2qI$  for all  $x_i \in \mathbb{D}$  and for some  $q > 0$ . If  $q, r, L_M$  are such that  $q > rL_M$ , then  $M(x) \preceq -qI, \forall x \in \mathcal{S}$ .

Proposition 1.6 implies that if the dataset is composed of a sufficiently fine grid, then the learned properties extend to the points in between. Hence, we can obtain a valid metric over a compact set by learning on a finite number of samples. Similar reasoning can be proposed for the feedback law  $\alpha$ .

The proposed algorithm has been tested in the leader-synchronization problem of a network of  $N = 6$  identical Lorenz attractors described by the following dynamics

$$\begin{cases} \dot{x}_{i,1} = a(x_{i,2} - x_{i,1}) + u_i \\ \dot{x}_{i,2} = x_{i,1}(b - x_{i,3}) - x_{i,2} + (2 + \sin(x_{i,1}))u_i \\ \dot{x}_{i,3} = x_{i,1}x_{i,2} - cx_{i,3} \end{cases}$$

with  $x_i = (x_{i,1}, x_{i,2}, x_{i,3}) \in \mathbb{R}^3$  and where  $a = 10, b = 28, c = \frac{8}{3}$ , guaranteeing the chaotic behavior. We consider the control matrix  $g(x) = (1, 2 + \sin(x_{i,1}), 0)$  to exclude the possibility of feedback linearizing solutions. The agents communicate with each other following the leader-connected graph represented in Figure 1.1a. Simulations are depicted in Figure 1.1.

## 1.6 Conclusions and perspectives

The content of this chapter is based on the contributions [D42–D49] which motivated the Ph.D. thesis of my Ph.D. student M. Giaccagli [87]. We investigated the design of contracting feedback laws for nonlinear systems based on a Riemannian metric contraction approach and two main different tools are proposed: the design of contracting infinite-gain margin laws [D43, D44] and the incremental forwarding approach [D46–D48]. The former is well motivated by its use in synchronization problems [D42, D49] addressed in Section 1.5, while the latter plays a

crucial role in the context of output regulation [D43, D46–D48], as we will further investigate in Chapter 3.

The proposed design are based on sufficient conditions but necessity has not been investigated. For instance, the Killing vector property is in general not necessary as highlighted in Section 1.5.2. Concerning the problem of state-synchronization of multi-agent systems, we addressed the problem of leader-connected graphs, but the theory of nonlinear system synchronization still lacks of more general results (i.e. nonleader directed weighted graphs) for which more complex analysis is needed (for instance relying on the use of edge’s Laplacian, see, e.g. [8]).

Finally, we remark that the proposed conditions are all based on the solution to a partial differential inequality which is in general very hard to verify with explicit solutions. As a consequence, one possibility is that of employing suitable approximation of those solutions and to restrict the solutions to semi-global (or regional) context. An example is given in Section 1.5.3 where a Deep Neural Network (DNN) is employed to learn the condition for the design of a contractive feedback. It would be interesting to follow a similar approach in the context of forwarding developed in Section 1.4.





# 2

## Stabilization of infinite dimensional systems

---

### Contents

---

<b>2.1 Preliminaries on abstract operators . . . . .</b>	<b>28</b>
<b>2.2 Stability of some semi-linear systems . . . . .</b>	<b>29</b>
2.2.1 Necessary and sufficient conditions . . . . .	29
2.2.2 Construction of ISS-Lyapunov functions via strictification . . . . .	30
2.2.3 An ISS-Lyapunov functional for the Korteweg-de-Vries equation . . . . .	33
<b>2.3 Forwarding for ODE-PDE cascades . . . . .</b>	<b>35</b>
2.3.1 Exponentially stable ODE and conservative PDE . . . . .	35
2.3.2 Scalar ODE coupled with a transport equation . . . . .	38
<b>2.4 Forwarding for PDE-ODE cascades . . . . .</b>	<b>39</b>
2.4.1 Exponentially Stable PDE and conservative ODE . . . . .	39
2.4.2 Korteweg-de Vries equation coupled with an integrator . . . . .	41
2.4.3 Heat equation coupled with a linear oscillator . . . . .	42
<b>2.5 Integral action control for PDEs . . . . .</b>	<b>43</b>
2.5.1 Anti-windup for linear abstract operators . . . . .	43
2.5.2 Integral action for the Korteweg-de Vries equation . . . . .	46
<b>2.6 Conclusions and perspectives . . . . .</b>	<b>48</b>

---

This chapter primarily focuses on developing design tools for stabilizing nonlinear couplings of partial differential equations (PDEs) and ordinary differential equations (ODEs). Such couplings may arise in various contexts, such as when actuator and/or sensor dynamics are governed by PDEs, as discussed in [119, 120]. Another case where such couplings naturally arise is in the problem of internal model-based regulators for output regulation problems, which will be reviewed in more detail in Chapter 3. In this case, the system to be controlled may be described by either an ODE or a PDE, and the internal model unit can be represented by an ODE (as in integral action controllers, e.g. [62, 127, 128, 155, 199]) or by a PDE (as in the case of Repetitive Control, e.g. [51, 97, 213]). However, while most of the existing techniques for stabilizing PDE-ODE couplings focus on linear dynamics, such as the well-celebrated backstepping technique [41, 120], few works address nonlinear dynamics.

The objective of this chapter is therefore to develop new Lyapunov-based techniques, mainly inspired from finite-dimensional nonlinear system theory, that can be applied to the context of stabilization of (possibly nonlinear) PDEs. After recalling a series of preliminary notions on

abstract operators, we provide in Section 2.2 a new set of sufficient and necessary conditions that can be used to study the stability of some semi-linear systems.

Then, in Section 2.2.2, we propose a new technique for strictifying an existing weak Lyapunov function. This approach is a direct extension of the work presented in [157], where the Lyapunov function associated to an observer is used for strictification. In the context of PDEs, we demonstrate how to apply this technique to general abstract linear systems, and then focus on the particular case of the Korteweg-de-Vries (KdV) equation. For such a KdV model, we show that the energy function can be strictified to derive an ISS Lyapunov function. Sections 2.3 and 2.4 build upon the forwarding approach discussed in Section 1.4 to design stabilization feedback for ODE-PDE and PDE-ODE cascades, respectively. These sections, along with the tools developed in Sections 2.2-2.4, are then used to derive integral-action based feedback in two different contexts. First, we propose an anti-windup based integral action for linear PDEs in the presence of input saturations. The forwarding approach in Section 2.4 and the set of sufficient conditions for the stability of semi-linear systems presented in Section 2.2 play a fundamental role. Finally, we address the problem of designing an integral action for a KdV model with boundary control. This is possible thanks to the existence of an ISS-Lyapunov function, as shown in Section 2.2.2.

## 2.1 Preliminaries on abstract operators

Given two Hilbert spaces  $\mathcal{H}_1$  and  $\mathcal{H}_2$ , the space  $\mathfrak{L}(\mathcal{H}_1, \mathcal{H}_2)$  denotes the space of operators bounded from  $\mathcal{H}_1$  to  $\mathcal{H}_2$ , and  $\mathfrak{L}(\mathcal{H}_1) = \mathfrak{L}(\mathcal{H}_1, \mathcal{H}_1)$ . Given a Hilbert space  $\mathcal{H}$ ,  $I_{\mathcal{H}}$  denotes the identity operator. For  $\mathbb{R}^n$ , this identity operator is given by  $I_n$ .

**Definition 2.1.** A family  $\mathbb{T} = (\mathbb{T}_t)_{t \geq 0}$  of operators in  $\mathfrak{L}(\mathcal{H})$  is a strongly continuous semigroup on  $\mathcal{H}$  if  $\mathbb{T}_0 = I$ ,  $\mathbb{T}_{t+\tau} = \mathbb{T}_t \mathbb{T}_\tau$  for every  $t, \tau \geq 0$ , and  $\lim_{t \rightarrow 0^+} \mathbb{T}_t v = v$  for all  $v \in \mathcal{H}$ .

**Definition 2.2.** Let  $\mathcal{H}$  be a Hilbert space. A  $C_0$ -semigroup  $\mathbb{T}(t)$  of bounded linear operators on  $\mathcal{H}$  is called (uniformly) exponentially stable, if there exist  $\nu, k > 0$  such that, for all  $t \in \mathbb{R}_{\geq 0}$

$$\|\mathbb{T}(t)\|_{\mathfrak{L}(\mathcal{H})} \leq k \exp(-\nu t). \quad (2.1)$$

**Definition 2.3.** An operator  $\mathcal{A} : D(\mathcal{A}) \subset \mathcal{H} \rightarrow \mathcal{H}$  is said to be dissipative if

$$\langle \mathcal{A}(w_1) - \mathcal{A}(w_2), w_1 - w_2 \rangle_{\mathcal{H}} \leq 0, \quad \forall w_1, w_2 \in D(\mathcal{A}). \quad (2.2)$$

**Definition 2.4.** An operator  $\mathcal{A} : D(\mathcal{A}) \subset \mathcal{H} \rightarrow \mathcal{H}$  is said to be maximal if there exists  $\lambda_0 > 0$  such that (equivalently, for all  $\lambda_0 > 0$ )

$$\text{Ran}(\lambda_0 I_{\mathcal{H}} - \mathcal{A}) = \mathcal{H}, \quad (2.3)$$

where  $I_{\mathcal{H}}$  is the identity operator over the Hilbert space  $\mathcal{H}$ , and  $\text{Ran}$  is the range operator.

**Definition 2.5.** An operator  $\mathcal{A} : D(\mathcal{A}) \subset \mathcal{H} \rightarrow \mathcal{H}$  is said to be  $m$ -dissipative if it is dissipative and maximal.

**Definition 2.6.** Let  $\mathcal{H}$  and  $\mathcal{Y}$  be two real Hilbert spaces,  $\mathcal{A} : D(\mathcal{A}) \subset \mathcal{H} \rightarrow \mathcal{H}$  be the generator of a strongly continuous semigroup  $(\mathbb{T}(t))_{t \geq 0}$  and  $\mathcal{C} \in \mathfrak{L}(\mathcal{X}, \mathcal{Y})$ . Let  $\psi \in \mathfrak{L}(D(\mathcal{A}), L^2([0, \infty); \mathcal{Y}))$  be defined by

$$(\psi w_0)(t) = \mathcal{C} \mathbb{T}(t) w_0, \quad \forall w_0 \in D(\mathcal{A}) \quad (2.4)$$

for all  $t \geq 0$ . Then, the pair  $(\mathcal{A}, \mathcal{C})$  is approximately observable in infinite-time if and only if  $\text{Ker } \psi = \{0\}$ .

A straightforward implication of this definition is that, if  $(\psi w_0)(t) = 0$  for all  $t \geq 0$ , then  $\mathbb{T}(t)w_0 = 0$  for all  $t \geq 0$ . Note that this definition is weaker than the one provided in [203, Definition 6.1.1], where this property is defined for a fixed time  $\tau$ .

We refer to [24, 65, 203] for more details and notion on abstract operators.

## 2.2 Stability of some semi-linear systems

Let  $\mathcal{X}$  be a Hilbert space equipped with a scalar product  $\langle \cdot, \cdot \rangle_{\mathcal{X}}$ , from which one can deduce a norm  $\| \cdot \|_{\mathcal{X}}$ . We consider in this section semi-linear systems of the form

$$\frac{d}{dt}x = \mathcal{F}x + \mathcal{G}\psi_L(\mathcal{L}x) := \mathcal{F}_{\psi}(x) \quad (2.5)$$

in which  $\mathcal{F} : D(\mathcal{F}) \subset \mathcal{X} \rightarrow \mathcal{X}$  is a linear operator which is an infinitesimal generator of a strongly continuous semigroup denoted  $(e^{t\mathcal{F}})_{t \geq 0}$ , the linear operators  $\mathcal{G} \in \mathfrak{L}(\mathbb{R}, \mathcal{X})$  and  $\mathcal{L} \in \mathfrak{L}(\mathcal{X}, \mathbb{R})$  are bounded, and  $\psi_L : \mathbb{R} \rightarrow \mathbb{R}$  is a function satisfying the following assumption.

**Definition 2.7.** *Given a real number  $L > 0$ , the function  $\psi_L : \mathbb{R} \rightarrow \mathbb{R}$  is a generalized saturation if it satisfies the following properties.*

1.  $\psi_L(0) = 0$ .
2.  $|\psi_L(s') - \psi_L(s'')| \leq |s' - s''|$  for any  $s', s'' \in \mathbb{R}$ .
3.  $\sup_{s \in \mathbb{R}} |\psi_L(s)| \leq L$ .

In particular,  $\psi_L$  is a continuous globally bounded function with Lipschitz constant equal to 1 (this value is arbitrarily and selected to one only to ease the presentation of this section). Next, we study the solution to system (2.5). The generalized saturation function being globally Lipschitz, applying [65, Theorem 11.1.5], the following well-posedness result follows. Note that we refer the reader to [65, Definition 11.1.3] and [65, Definition 11.1.2] for the definitions of mild and classical solutions, respectively.

**Proposition 2.1.** *For any  $x_0 \in \mathcal{X}$  (resp.  $x_0 \in D(\mathcal{F})$ ), there exists a unique mild (resp. classical) solution  $x \in C(\mathbb{R}_{\geq 0}; \mathcal{X})$  (resp.  $x \in C^1(\mathbb{R}_{\geq 0}; \mathcal{X}) \cap C(\mathbb{R}_{\geq 0}; D(\mathcal{F}))$ ), that we will denote by  $x(t) := e^{\mathcal{F}_{\psi} t}(x_0)$ , to (2.5).*

We study now the exponential stability of the origin of (2.5). This notion of stability is defined as follows.

**Definition 2.8.** *The origin is said to be globally exponentially stable for system (2.5) if there exist positive real numbers  $c$  and  $\lambda$  such that  $\|e^{\mathcal{F}_{\psi} t}(x_0)\|_{\mathcal{X}} \leq ce^{-\lambda t}\|x_0\|_{\mathcal{X}}$  for all  $(x_0, t)$  in  $\mathcal{X} \times \mathbb{R}_{\geq 0}$ .*

It has to be noticed that in this property it is required that the positive real number  $c$  and  $\lambda$  are uniform. In the following part of this section a necessary condition and two sufficient conditions are given to obtain this global exponential stability property.

### 2.2.1 Necessary and sufficient conditions

We start by stating the following necessary condition in the same spirit of some other results related to feedback stabilization with saturated control, e.g. [195, Theorem 2.2, Chapter 2.4.4] or [93, Theorem 1], although these results are based on the existence of a quadratic Lyapunov function (differently from the proposed proof which is based on a trajectory analysis, see [D18]).

**Proposition 2.2** (Necessary Conditions). *The origin of system (2.5) is globally exponentially stable only if the origin of  $\frac{d}{dt}x = \mathcal{F}x$  is exponentially stable.*

Sufficient conditions exist to prove the asymptotic stability from separate properties on the linear operator and on the semilinear map. In our context, we give sufficient conditions based on Lyapunov consideration. Before presenting the next result, we provide the definition of coercive Lyapunov functionals for linear systems, that will be used all along the sequel (see [142, Definition 2.11] for the definition of coercive Lyapunov functionals for more general systems).

**Definition 2.9.** *Let  $\mathcal{F} : D(\mathcal{F}) \subset \mathcal{X} \rightarrow \mathcal{X}$  be a linear operator generating a strongly continuous semigroup. A functional  $V(x) := \langle \mathcal{P}x, x \rangle_{\mathcal{X}}$ , with  $\mathcal{P} \in \mathfrak{L}(\mathcal{X})$  a self-adjoint operator, is said to be a coercive Lyapunov functional for  $\mathcal{F}$  if there exist positive constants  $\alpha$  and  $\lambda$  satisfying*

$$\begin{aligned} \alpha \|x\|_{\mathcal{X}}^2 &\leq V(x), & \forall x \in \mathcal{X}, \\ \langle \mathcal{F}x, \mathcal{P}x \rangle_{\mathcal{X}} + \langle \mathcal{P}x, \mathcal{F}x \rangle_{\mathcal{X}} &\leq -\lambda \|x\|_{\mathcal{X}}^2, & \forall x \in D(\mathcal{F}). \end{aligned}$$

Inequality (2.6) and the assumption  $\mathcal{P} \in \mathfrak{L}(\mathcal{X})$  imply in particular that  $\sqrt{V(\cdot)}$  is equivalent to the usual norm  $\|\cdot\|_{\mathcal{X}}$ . Note that the existence of non-coercive Lyapunov functional (possibly implying a non-equivalence between  $\sqrt{V(\cdot)}$  and  $\|\cdot\|_{\mathcal{X}}$ ) is a particular feature of infinite-dimensional systems, as discussed in [143].

In the following, two sufficient conditions for the exponential stability of the origin of systems of the form (2.5) are stated. The first condition is based on a “small-gain control property” which extends the result [189, Theorem 2.4] presented in the case of finite-dimensional linear systems in the particular case in which the function  $\psi_L$  is a saturation function. It is a trivial extension of the fact that exponential stability is robust to *small* Lipschitz perturbations in the dynamics when there exists a coercive Lyapunov functional.

**Proposition 2.3.** *Consider system (2.5) with the function  $\psi_L$  satisfying Definition 2.7. Suppose that there exists a coercive Lyapunov functional  $V$  for  $\mathcal{F}$  given by, for all  $x \in \mathcal{X}$ ,  $V(x) := \langle \mathcal{P}x, x \rangle_{\mathcal{X}}$  for some  $\mathcal{P} \in \mathfrak{L}(\mathcal{X})$ . Then, for all bounded linear operator  $\mathcal{L} : \mathcal{X} \rightarrow \mathcal{X}$  satisfying  $\|\mathcal{L}\|_{\mathfrak{L}(\mathcal{X}, \mathbb{R})} < \frac{\lambda}{2\|\mathcal{P}\mathcal{G}\|_{\mathcal{X}}}$  the origin of (2.5) is globally exponentially stable.*

The second sufficient condition is based on the existence of a common coercive Lyapunov functional between the operators  $\mathcal{F}$  and  $\mathcal{F} + \mathcal{G}\mathcal{L}$ . For the finite-dimensional case in which the function  $\psi_L$  is a saturation function this result is well known, see, e.g. [173].

**Proposition 2.4.** *Consider system (2.5) with the function  $\psi_L$  satisfying Definition 2.7. Suppose there exists a common coercive Lyapunov functional  $V$  for  $\mathcal{F}$  and  $\mathcal{F} + \mathcal{G}\mathcal{L}$ , namely there exists a functional  $V$  defined as  $V(x) := \langle \mathcal{P}x, x \rangle_{\mathcal{X}}$ , for all  $x$  in  $\mathcal{X}$ , satisfying (2.6) and*

$$\begin{aligned} \langle \mathcal{F}x, \mathcal{P}x \rangle_{\mathcal{X}} + \langle \mathcal{P}x, \mathcal{F}x \rangle_{\mathcal{X}} &\leq -\lambda \|x\|_{\mathcal{X}}^2 \\ \langle (\mathcal{F} + \mathcal{G}\mathcal{L})x, \mathcal{P}x \rangle_{\mathcal{X}} + \langle \mathcal{P}x, (\mathcal{F} + \mathcal{G}\mathcal{L})x \rangle_{\mathcal{X}} &\leq -\lambda \|x\|_{\mathcal{X}}^2 \end{aligned}$$

for all  $x \in D(\mathcal{F})$ , for some  $\lambda > 0$ . Then the origin of (2.5) is globally exponentially stable.

## 2.2.2 Construction of ISS-Lyapunov functions via strictification

The construction of strict ISS Lyapunov function for PDEs is an important problem which is widely open, see, e.g. [142, 143]. Inspired by the recent work [157], in this section we study the

problem of strictification of weak Lyapunov functions (which often coincide with the Energy or  $L^2$  norm of the system) based on observers design. Consider in particular a system of the form

$$\begin{aligned}\frac{d}{dt}x(t) &= \mathcal{A}x(t) + \mathcal{B}u(t) \\ y(t) &= \mathcal{C}x(t),\end{aligned}\tag{2.6}$$

where  $\mathcal{A}$  is the generator of a  $C_0$ -semigroup  $\mathbb{T}(t)$  on a Hilbert space  $\mathcal{X}$ , and  $\mathcal{B} : \mathbb{R}^m \rightarrow \mathcal{X}$  and  $\mathcal{C} : D(\mathcal{A}) \rightarrow \mathcal{Y}$  are bounded operators. Given a system of the form (2.6), we study the link between exponential stability of the semigroup generated by  $\mathcal{A}$  and the detectability of the pair  $(\mathcal{A}, \mathcal{C})$ .

To this end, associated to  $\mathbb{T}(t)$  we consider the convolution operator on  $L^p(\mathbb{R}_{\geq 0}, \mathcal{X})$ ,  $1 \leq p < \infty$  defined by

$$(\mathcal{G}f)(t) := \int_0^t \mathbb{T}(s)f(t-s)ds.\tag{2.7}$$

In [56], the operator  $\mathcal{G}$  is called the Green operator.

**Theorem 2.1.** *Let  $1 \leq p < \infty$ . The semigroup  $\mathbb{T}(t)$  is exponentially stable if and only if the operator  $\mathcal{G}$  is a bounded operator from  $L^p(\mathbb{R}_{\geq 0}, \mathcal{X})$  to itself.*

We call  $(\mathcal{A}, \mathcal{C})$  detectable, if there exists a bounded linear operator  $\mathcal{L} \in \mathfrak{L}(\mathcal{Y}, \mathcal{X})$  such that  $(\mathcal{A} + \mathcal{L}\mathcal{C})$  generates an exponentially stable semigroup. Associated to the operators  $\mathcal{C}, \mathcal{L}$  we consider multiplication operators on appropriate  $L^p$ -spaces defined by

$$\mathcal{C} : L^p(\mathbb{R}_{\geq 0}, \mathcal{X}) \rightarrow L^p(\mathbb{R}_{\geq 0}, \mathcal{Y}), \quad f(\cdot) \mapsto \mathcal{C}f(\cdot),\tag{2.8}$$

$$\mathcal{L} : L^p(\mathbb{R}_{\geq 0}, \mathcal{Y}) \rightarrow L^p(\mathbb{R}_{\geq 0}, \mathcal{X}), \quad g(\cdot) \mapsto \mathcal{L}g(\cdot),\tag{2.9}$$

The following can be found in [56, Theorem 5.3].

**Theorem 2.2.** *The following are equivalent:*

1.  $\mathbb{T}(t)$  is exponentially stable.
2.  $(\mathcal{A}, \mathcal{C})$  is detectable and  $\mathcal{C}\mathcal{G}$  is a bounded operator from  $L^p(\mathbb{R}_{\geq 0}, \mathcal{X})$  to  $L^p(\mathbb{R}_{\geq 0}, \mathcal{Y})$ .

Another way to obtain exponential decrease of the semi-group is to follow a more direct Lyapunov approach and to *strictify* the Lyapunov function. Assuming that  $\mathcal{C}$  is a detectable output and assuming moreover that  $\mathcal{Q}\mathcal{K}\mathcal{C}$  is a  $\mathcal{C}$ - bounded operator it is possible to follow the approach introduced in [157]. This theorem directly follows his ideas.

**Theorem 2.3.** *Let  $\mathcal{X}$  be a Hilbert space and  $\mathcal{A} : D(\mathcal{A}) \subset \mathcal{X} \rightarrow \mathcal{X}$  be the infinitesimal generator of a  $C_0$ -semigroup  $(\mathbb{T}(t))_{t \geq 0}$ . Assume there exists a linear map  $\mathcal{C} : D(\mathcal{A}) \mapsto \mathcal{Y}$  where  $\mathcal{Y}$  is a Banach space such that for all  $\varphi$  in  $D(\mathcal{A})$ ,*

$$\langle \mathcal{A}\varphi, \mathcal{P}\varphi \rangle_{\mathcal{X}} + \langle \mathcal{P}\varphi, \mathcal{A}\varphi \rangle_{\mathcal{X}} \leq -\|\mathcal{C}\varphi\|_{\mathcal{Y}}^2.\tag{2.10}$$

Assume moreover that there exist  $\mathcal{K} : \mathcal{C}(D(\mathcal{A})) \mapsto \mathcal{X}$  and a bounded self adjoint operator  $\mathcal{Q} : \mathcal{X} \mapsto \mathcal{X}$  and a positive real number  $\alpha$  such that

$$\langle (\mathcal{A} - \mathcal{K}\mathcal{C})\varphi, \mathcal{Q}\varphi \rangle_{\mathcal{X}} + \langle \mathcal{Q}\varphi, (\mathcal{A} - \mathcal{K}\mathcal{C})\varphi \rangle_{\mathcal{X}} \leq -\|\varphi\|_{\mathcal{X}}^2,\tag{2.11}$$

and

$$\|\mathcal{Q}\mathcal{K}\mathcal{C}\|_{\mathcal{X}} \leq \alpha\|\mathcal{C}\|_{\mathcal{Y}}$$

Then the semigroup  $\mathbb{T}(t)$  is exponentially stable.

Next, we gave the (rather short) proof of the previous theorem, since it has not been published/submitted anywhere at the time of the writing of this publication. The proof has been written in collaboration with Fabian Wirth and Vincent Andrieu.

*Proof.* Let  $\varepsilon > 0$ , note that

$$\begin{aligned} \langle \mathcal{A}\varphi, (\mathcal{P} + \varepsilon\mathcal{Q})\varphi \rangle_{\mathcal{X}} + \langle (\mathcal{P} + \varepsilon\mathcal{Q})\varphi, \mathcal{A}\varphi \rangle_{\mathcal{X}} &\leq \\ &\leq -\|\mathcal{C}\varphi\|_{\mathcal{Y}}^2 + \varepsilon(\langle \mathcal{A}\varphi, \mathcal{Q}\varphi \rangle_{\mathcal{X}} + \langle \mathcal{Q}\varphi, \mathcal{A}\varphi \rangle_{\mathcal{X}}) \\ &\leq -\|\mathcal{C}\varphi\|_{\mathcal{Y}}^2 + \varepsilon(\langle (\mathcal{A} - \mathcal{K}\mathcal{C})\varphi, \mathcal{Q}\varphi \rangle_{\mathcal{X}} + \langle \mathcal{Q}\varphi, (\mathcal{A} - \mathcal{K}\mathcal{C})\varphi \rangle_{\mathcal{X}}) \\ &\quad + \varepsilon(\langle \mathcal{K}\mathcal{C}\varphi, \mathcal{Q}\varphi \rangle_{\mathcal{X}} + \langle \mathcal{Q}\varphi, \mathcal{K}\mathcal{C}\varphi \rangle_{\mathcal{X}}) \\ &\leq -\|\mathcal{C}\varphi\|_{\mathcal{Y}}^2 - \varepsilon\|\varphi\|_{\mathcal{X}}^2 + 2\varepsilon \left| \left\langle \frac{\mathcal{Q}\mathcal{K}\mathcal{C}}{\nu}\varphi, \nu\varphi \right\rangle_{\mathcal{X}} \right|. \end{aligned}$$

With Cauchy-Schwartz and Young inequality we obtain

$$\begin{aligned} \langle \mathcal{A}\varphi, (\mathcal{P} + \varepsilon\mathcal{Q})\varphi \rangle_{\mathcal{X}} + \langle (\mathcal{P} + \varepsilon\mathcal{Q})\varphi, \mathcal{A}\varphi \rangle_{\mathcal{X}} &\leq -\|\mathcal{C}\varphi\|_{\mathcal{Y}}^2 - \varepsilon\|\varphi\|_{\mathcal{X}}^2 + 2\varepsilon\alpha\|\mathcal{C}\varphi\|_{\mathcal{Y}}\|\varphi\|_{\mathcal{X}} \\ &\leq -\|\mathcal{C}\varphi\|_{\mathcal{Y}}^2 - \varepsilon\|\varphi\|_{\mathcal{X}}^2 + \frac{\varepsilon\alpha}{\nu}\|\mathcal{C}\varphi\|_{\mathcal{Y}}^2 + \nu\varepsilon\alpha\|\varphi\|_{\mathcal{X}}. \end{aligned}$$

Hence, with  $\nu = 2\varepsilon\alpha$ , it implies

$$\langle \mathcal{A}\varphi, (\mathcal{P} + \varepsilon\mathcal{Q})\varphi \rangle_{\mathcal{X}} + \langle (\mathcal{P} + \varepsilon\mathcal{Q})\varphi, \mathcal{A}\varphi \rangle_{\mathcal{X}} \leq -\frac{1}{2}\|\mathcal{C}\varphi\|_{\mathcal{Y}}^2 - \varepsilon(1 - 2\varepsilon\alpha^2)\|\varphi\|_{\mathcal{X}}^2.$$

Picking  $\varepsilon = \frac{1}{4\alpha^2}$ , it finally implies

$$\langle \mathcal{A}\varphi, (\mathcal{P} + \varepsilon\mathcal{Q})\varphi \rangle_{\mathcal{X}} + \langle (\mathcal{P} + \varepsilon\mathcal{Q})\varphi, \mathcal{A}\varphi \rangle_{\mathcal{X}} \leq -\frac{1}{2}\|\mathcal{C}\varphi\|_{\mathcal{Y}}^2 - \frac{\varepsilon}{2}\|\varphi\|_{\mathcal{X}}^2.$$

Finally, exponential stability is obtained from Datko's lemma. □

From previous computations, it can be verified that the system

$$\frac{d}{dt}\hat{x} = \mathcal{A}\hat{x} + \mathcal{B}u + \mathcal{K}(y - \mathcal{C}\hat{x})$$

is an observer for system (2.6) and the estimation error  $\hat{x} - x$  converges exponentially to zero for any initial condition. This can be indeed certified with the Lyapunov functional associated to the operator  $\mathcal{Q}$ , see (2.11).

Finally, following the proof of Theorem 2.3 we can construct a strict ISS-Lyapunov functional for system (2.6) as

$$\mathcal{S} = \mathcal{P} + \varepsilon\mathcal{Q}, \quad \varepsilon = \frac{1}{4\alpha^2}.$$

Indeed, it can be verified that there exists  $\gamma > 0$  such that

$$\langle \mathcal{A}\varphi + \mathcal{B}u, \mathcal{S}\varphi \rangle_{\mathcal{X}} + \langle \mathcal{S}\varphi, \mathcal{A}\varphi + \mathcal{B}u \rangle_{\mathcal{X}} \leq -\frac{1}{2}\|\mathcal{C}\varphi\|_{\mathcal{Y}}^2 - \frac{\varepsilon}{4}\|\varphi\|_{\mathcal{X}}^2 + \gamma|u|^2$$

for any  $\varphi \in D(\mathcal{A})$  and  $u \in \mathbb{R}^m$ .

### 2.2.3 An ISS-Lyapunov functional for the Korteweg-de-Vries equation

The Korteweg-de-Vries (KdV) equation is a mathematical model of waves on shallow water surfaces, see e.g., [52] for a survey. Following the main construction of the previous section, we study here the existence of a strict ISS-Lyapunov functional for the KdV model described by

$$\begin{cases} w_t(t, x) + w_x(t, x) + w_{xxx}(t, x) = u(t, x), & (t, x) \in \mathbb{R}_{\geq 0} \times [0, L], \\ w(t, 0) = w(t, L) = 0, & t \in \mathbb{R}_{\geq 0}, \\ w_x(t, L) = d(t), & t \in \mathbb{R}_{\geq 0}, \\ w(0, x) = w_0(x). & x \in [0, L], \end{cases} \quad (2.12)$$

where  $w \in L_2(0, L)$  is the state and  $u$  is a distributed disturbance and  $d$  is a disturbance acting at the boundary. A nonlinear version of the equation (2.12) is given by the model

$$\begin{cases} w_t(t, x) + w_x(t, x) + w_{xxx}(t, x) + w(t, x)w_x(t, x) = u(t, x), & (t, x) \in \mathbb{R}_{\geq 0} \times [0, L], \\ w(t, 0) = w(t, L) = 0, & t \in \mathbb{R}_{\geq 0}, \\ w_x(t, L) = d(t), & t \in \mathbb{R}_{\geq 0}, \\ w(0, x) = w_0(x). & x \in [0, L], \end{cases} \quad (2.13)$$

A formal computation shows that in the absence of disturbances, namely when  $u = 0$  and  $d = 0$ , the time derivative of the energy  $E$  defined as

$$E(w) := \int_0^L w(t, x)^2 dx \quad (2.14)$$

yields along solutions to (2.12) or (2.13)

$$\dot{E}(w) := \frac{d}{dt} \int_0^L w(t, x)^2 dx = -|w_x(t, 0)|^2. \quad (2.15)$$

Evidently, the energy  $E$  function is not a strict Lyapunov functional but only weak (because  $|w_x(\cdot, 0)|$  is not equivalent to the norm of  $|w|_{L^2}$ ). However, it can be shown that since  $w_x(\cdot, 0)$  is an exactly observable output as soon as  $L \notin \mathcal{N}$  with

$$\mathcal{N} := \left\{ 2\pi \sqrt{\frac{k^2 + kl + l^2}{3}} : k, l \in \mathbb{N} \right\}, \quad (2.16)$$

exponential stability can be further concluded. This analysis falls in the context of Section 2.2.2. However, since the operator associated to the output  $w_x(\cdot, 0)$  is not bounded, we cannot apply on the shelf Theorem 2.3 but we need a finer analysis. To this end, we first recall the following result concerning the existence of solutions to the KdV equations given in [53, Theorem 9].

**Proposition 2.5.** *For any  $T, L > 0$ , for any  $w_0 \in L^2(0, L)$ , for any  $u \in L^1([0, T]; L^2(0, L))$  and  $d \in L^2(0, T)$ , systems (2.13) and (2.12) admit a unique mild solution*

$$w \in C^0([0, T]; L^2(0, L)) \cap L^2(0, T; H^1(0, L)).$$

The second result deals with more regular solutions, see [37, Theorem 1.3] or [64, Proposition 7]. The statement reads as follows.

**Proposition 2.6.** *For any  $T, L > 0$ , for any  $w_0 \in H_L^3(0, L)$ , for any  $u \in C^1([0, T], L^2(0, L))$  and  $d \in C^2([0, T])$ , systems (2.13) and (2.12) admit a unique classical solution*

$$w \in C(0, T; H^3(0, L)) \cap C^1(0, T; L^2(0, L)).$$



Next, we state the following definition of ISS-Lyapunov functional for systems (2.13) and (2.12).

**Definition 2.10.** A Fréchet differentiable function  $V : L^2(0, L) \rightarrow \mathbb{R}$  is said to be an exponentially ISS Lyapunov functional for the system (2.13) (resp. (2.12)), if there exist positive constants  $\underline{\alpha}, \bar{\alpha}, \alpha, \sigma_1, \sigma_2$  such that:

(i) For all  $w \in L^2(0, L)$ ,

$$\underline{\alpha}\|w\|_{L^2}^2 \leq V(w) \leq \bar{\alpha}\|w\|_{L^2}^2.$$

(ii) The time derivative of  $V$  along the trajectories of (2.13) (resp. (2.12)) satisfies

$$\dot{V}(w) \leq -\alpha\|w\|_{L^2}^2 + \sigma_1\|u\|_{L^2}^2 + \sigma_2|d|^2,$$

for any  $w \in L^2(0, L)$ ,  $u \in L^2(0, L)$  and  $d \in \mathbb{R}$ . If there exists  $\delta > 0$  such that (ii) holds only if  $\|w\|_{L^2} + \|u\|_{L^2} + |d| \leq 3\delta$  then  $V$  is said to be a locally exponentially ISS Lyapunov functional for the system (2.13).

Hence, we have the following theorem certifying the existence of a Lyapunov functional for the KdV model.

**Theorem 2.4.** Suppose that  $L \notin \mathcal{N}$ . Then, there exists a functional  $W : L^2(0, L) \rightarrow \mathbb{R}_{\geq 0}$  such that, the function  $V(w) := W(w) + E(w)$  with  $E$  being the energy in  $L^2$ -norm defined in (2.14), is

(a) an exponentially ISS Lyapunov functional for the system (2.12);

(b) a locally exponentially ISS Lyapunov functional for the system (2.13).

Moreover, the functional  $W$  is given by  $W(w) := \varepsilon\|\Pi^{-1}(w)\|_{L^2}^2$  with  $\Pi^{-1}$  being a continuous linear operator from  $L^2(0, L)$  to  $L^2(0, L)$  with a continuous inverse, and  $\varepsilon > 0$  to be chosen small enough.

The operator  $\Pi$  is based on the existence of an observer for the the linear KdV equation (2.12) with  $y(t) = w_x(t, 0)$  defined as the output function. Indeed, given

$$\begin{cases} w_t(t, x) + w_x(t, x) + w_{xxx}(t, x) = u(t, x), & (t, x) \in \mathbb{R}_{\geq 0} \times [0, L], \\ w(t, 0) = w(t, L) = 0, & t \in \mathbb{R}_{\geq 0}, \\ w_x(t, L) = d(t), & t \in \mathbb{R}_{\geq 0}, \\ w(0, x) = w_0(x), & x \in [0, L], \\ y(t) = w_x(t, 0), & t \in \mathbb{R}_{\geq 0}, \end{cases} \quad (2.17)$$

we can define an observer with a distributed correction term of the form

$$\begin{cases} \hat{w}_t(t, x) + \hat{w}_x(t, x) + \hat{w}_{xxx}(t, x) + \kappa(x)[y(t) - \hat{w}_x(t, 0)] = 0, & (t, x) \in \mathbb{R}_{\geq 0} \times [0, L], \\ \hat{w}(t, 0) = \hat{w}(t, L) = 0, & t \in \mathbb{R}_{\geq 0}, \\ \hat{w}_x(t, L) = 0, & t \in \mathbb{R}_{\geq 0}, \\ \hat{w}(0, x) = \hat{w}_0(x), & x \in [0, L], \end{cases} \quad (2.18)$$

where  $\kappa$  is an output injection gain to be designed which can be obtained for instance following standard *backstepping*<sup>1</sup> approach, e.g. [41]. In particular, similar to [63, equation (1.8)], it consists in looking for a change of coordinates

$$v \mapsto \gamma := \Pi^{-1}\tilde{w} \quad (2.19)$$

---

<sup>1</sup>With the terminology of “backstepping” according to the infinite-dimensional literature, and not to the finite-dimensional one!

mapping a system of the form

$$\begin{cases} v_t(t, x) + v_x(t, x) + v_{xxx}(t, x) - \kappa(x)v_x(t, 0) = 0, & (t, x) \in \mathbb{R}_{\geq 0} \times [0, L], \\ v(t, 0) = v(t, L) = v_x(t, L) = 0, & t \in \mathbb{R}_{\geq 0}, \\ v(0, x) = v_0(x), & x \in [0, L], \end{cases}$$

into an exponentially stable system of the form

$$\begin{cases} \gamma_t(t, x) + \gamma_x(t, x) + \gamma_{xxx}(t, x) + \lambda\gamma(t, x) = 0, & (t, x) \in \mathbb{R}_{\geq 0} \times [0, L], \\ \gamma(t, 0) = \gamma(t, L) = \gamma_x(t, L) = 0, & t \in \mathbb{R}_{\geq 0}, \\ \gamma(0, x) = \gamma_0(x), & x \in [0, L], \end{cases}$$

with  $\lambda > 0$ . The function  $\Pi$  in (2.19) can be obtained using the Fredholm transformation

$$v(x) = \Pi(\gamma)(x) := \gamma(x) - \int_0^L \pi(x, z)\gamma(z)dz, \quad \forall x \in [0, L],$$

where  $\pi$  is a Kernel function satisfying the following PDE

$$\begin{cases} \pi_z(x, z) + \pi_{zzz}(x, z) + \pi_x(x, z) + \pi_{xxx}(x, z) - \lambda\pi(x, z) = \lambda\delta(x - z), \\ \pi(x, 0) = \pi(x, L) = 0, \\ \pi(L, z) = \pi(0, z) = 0, \\ \pi_x(L, z) = \pi_x(0, z) = 0. \end{cases}$$

where  $(x, z) \in [0, L] \times [0, L]$  and  $\delta(x - z)$  denoting the Dirac measure on the diagonal of the square  $[0, L] \times [0, L]$ . Existence and uniqueness of such a PDE has been studied in [63, Lemma 2.1],

Finally, it can be shown that the function  $U : L^2(0, L) \rightarrow \mathbb{R}_{\geq 0}$  defined as

$$U(w) := \|\Pi^{-1}(\tilde{w})\|_{L^2}^2$$

is a (strict) ISS-Lyapunov functional for the error estimation error  $\tilde{w} := \hat{w} - w$  with respect to the disturbances  $u, d$ . In other words, the observer (2.18) is an ISS observer for plant (2.17) with respect to the disturbances  $u, d$ .

## 2.3 Forwarding for ODE-PDE cascades

### 2.3.1 Exponentially stable ODE and conservative PDE

Let  $\mathcal{H}$  be a Hilbert space equipped with a scalar product  $\langle \cdot, \cdot \rangle_{\mathcal{H}}$  and the corresponding norm  $\|\cdot\|_{\mathcal{H}}$ . In this paper we are interested in the stabilization (at the origin) problem for systems that can be described as a cascade of two systems reading as follows

$$\begin{aligned} \frac{d}{dt}z &= Az + Bu, & z(0) &= z_0 \\ y &= Cz, \\ \frac{d}{dt}w &= Sw + Gy, & w(0) &= w_0, \end{aligned} \tag{2.20}$$

where the state component  $z$  lives in an Euclidean space  $\mathbb{R}^n$ ,  $w$  is a (possibly infinite-dimensional) state living in the Hilbert space  $\mathcal{H}$ ,  $u \in \mathbb{R}^m$  is the control input and  $y \in \mathbb{R}^p$  is an interconnection signal between the  $z$  and the  $w$ -dynamics. We suppose that  $S : D(S) \subseteq \mathcal{H} \rightarrow \mathcal{H}$  is a (possibly unbounded) operator, with  $D(S)$  densely defined in  $\mathcal{H}$ . Defining  $\mathcal{H}_{-1}$  as the completion of  $\mathcal{H}$  with respect to the norm  $\|w\|_{-1} := \|(\beta I_{\mathcal{H}} - S)^{-1}w\|_{\mathcal{H}}$ , where  $\beta$  is in the resolvent of  $S$ , we suppose that  $G \in \mathcal{L}(\mathbb{R}^p, \mathcal{H}_{-1})$ , i.e.  $G$  is a bounded operator from  $\mathbb{R}^p$  to  $\mathcal{H}_{-1}$ . We state the following set of assumptions.

**Assumption 2.1.** *The following statements hold.*

- The operator  $S : D(S) \subseteq \mathcal{H} \rightarrow \mathcal{H}$  generates a strongly continuous semigroup of contractions, that is denoted by  $(\mathbb{T}(t))_{t \geq 0}$  and therefore  $S$  is dissipative (see Definition 2.3).
- The matrix  $A$  is Hurwitz.
- The spectra of  $S$  and  $A$  are disjoint and nonempty.
- The operator  $\mathcal{G}$  is infinite-time admissible for  $\mathbb{T}$ , which means by [203, Definition 4.6.1] that the operator<sup>2</sup>

$$\begin{aligned} \Phi_t : L^2([0, \infty); \mathbb{R}^p) &\rightarrow \mathcal{H}_{-1} \\ y &\mapsto \int_0^t \mathbb{T}(t-s) \mathcal{G}y(s) ds, \end{aligned} \quad (2.21)$$

is such that for all  $t \geq 0$   $\text{Ran } \Phi_t \subset \mathcal{H}$  and  $(\|\Phi_t\|_{\mathcal{L}(L^2([0, \infty); \mathbb{R}^p), \mathcal{H})})_{t \geq 0}$  is bounded.

System (2.20) can be viewed as an infinite-dimensional control system in which the  $z$ -dynamics represent the actuator's dynamics [77]. Another interpretation is to see the  $w$ -dynamics as an infinite-dimensional regulator in output regulation problems, see, e.g. [149], [213]. For this class of system we can directly extend the forwarding approach, presented in Section 1.4. Following a similar development to the one detailed in the linear case, we introduce the operator  $\mathcal{M} : \mathbb{R}^n \rightarrow \mathcal{H}_{-1}$  defined as solution to

$$\mathcal{M}A = \mathcal{S}\mathcal{M} + \mathcal{G}C, \quad (2.22)$$

where  $\mathcal{S}$  is understood as the extension of the operator  $S$  in  $\mathcal{H}_{-1}$ . In view of Assumption 2.1, the solution  $\mathcal{M} : \mathbb{R}^n \rightarrow \mathcal{H}_{-1}$  to (2.22) is unique and is given by the explicit formula

$$\mathcal{M} := - \int_0^\infty \mathbb{T}(t) \mathcal{G}C e^{-tA} dt.$$

See, e.g., [153, Lemma 22]. Furthermore,  $\text{Ran } \mathcal{M} \subset \mathcal{H}$ . In particular, for all  $\varphi \in \mathbb{R}^n$ ,  $\mathcal{S}\mathcal{M}\varphi + \mathcal{G}C\varphi \in \mathcal{H}$ . Based on the Lyapunov function

$$V(z, w) = z^\top Pz + \|w - \mathcal{M}z\|_{\mathcal{H}}^2$$

with  $P$  solution to  $PA + A^\top P = -I$ , and by recalling that the operator  $S$  is dissipative according to the Definition 2.3, one can derive a natural candidate control  $u$  of the form

$$u = -\mu B^\top [Pz - \mathcal{M}^*(w - \mathcal{M}z)], \quad \mu > 0, \quad (2.23)$$

which allows to conclude that

$$\frac{d}{dt} V(z, w) \leq -|z|^2 - \mu |u|^2.$$

The closed-loop is then written in the more compact form

$$\frac{d}{dt} \xi = \mathcal{F}(\xi), \quad \xi(0) = \xi_0, \quad (2.24)$$

where  $\xi = (z, w)$  and

$$\mathcal{F}(\xi) = \begin{bmatrix} Az - \mu BB^\top (Pz - \mathcal{M}^*(w - \mathcal{M}z)) \\ Sw + \mathcal{G}Cz \end{bmatrix}.$$

---

<sup>2</sup>Here, the semigroup  $(\mathbb{T}(t))_{t \geq 0}$  is the extension of the semigroup generated by  $S$  on  $\mathcal{H}_{-1}$ .

The domain  $D(\mathcal{F})$  of  $\mathcal{F}$  is defined as

$$D(\mathcal{F}) := \{(z, w) \in \mathcal{X} : \mathcal{S}w + \mathcal{G}Cz \in \mathcal{H}\},$$

where  $\mathcal{X} := \mathbb{R}^n \times \mathcal{H}$  is equipped with the norm defined by  $\|(z, w)\|_{\mathcal{X}} = |z| + \|w\|_{\mathcal{H}}$ . The resulting closed-loop is well-posed (i.e. its solutions exist) according to the following result.

**Theorem 2.5.** *Suppose Assumption 2.1 is satisfied. Then, the following statements hold.*

1. *For every initial conditions  $(z_0, w_0) \in \mathcal{X}$ , there exists a unique weak solution  $(z, w) \in C^0(\mathbb{R}_{\geq 0}; \mathcal{X})$  to the closed-loop system (2.24). Moreover, for all  $t \geq 0$ ,*

$$\|(z(t), w(t))\|_{\mathcal{X}} \leq \|(z_0, w_0)\|_{\mathcal{X}}.$$

2. *For every initial conditions  $(z_0, w_0) \in D(\mathcal{F})$ , there exists a unique strong solution  $(z, w) \in C^1(\mathbb{R}_{\geq 0}; \mathcal{X}) \cap C^0(\mathbb{R}_{\geq 0}; D(\mathcal{F}))$  to the closed-loop system (2.24). Moreover, for all  $t \geq 0$ ,*

$$\|(z(t), w(t))\|_{D(\mathcal{F})} \leq \|(z_0, w_0)\|_{D(\mathcal{F})}$$

In order to guarantee also the stability properties of the origin of (2.24), we also need an extra observability property.

**Theorem 2.6.** *Suppose that Assumption 2.1 holds. Moreover, assume the following:*

- *$(\mathcal{S}, B^\top \mathcal{M}^*)$  is approximately observable in infinite-time;*
- *$\mathcal{S}$  has compact resolvent.*

*Then, the origin of (2.24) is globally asymptotically stable in  $\mathcal{X}$ , that is, for every initial condition  $(z_0, w_0) \in \mathcal{X}$ , the origin is globally asymptotically stable.*

In the case where  $\mathcal{S}$  is a skew-adjoint operator with compact resolvent, we have also the following test to verify the observability condition of the pair  $(\mathcal{S}, B^\top \mathcal{M}^*)$  needed in the previous theorem.

**Proposition 2.7.** *Suppose that the following properties hold:*

- *The operator  $\mathcal{S}$  is skew-adjoint with compact resolvent;*
- *The pair  $(\mathcal{S}^*, \mathcal{G}^*)$  is approximately observable in infinite-time;*
- *For all eigenvalue  $\lambda$  of  $\mathcal{S}$ ,*

$$\text{rank} \begin{pmatrix} A - \lambda I_n & B \\ C & 0 \end{pmatrix} = n + p. \quad (2.25)$$

*Then, the pair  $(\mathcal{S}, B^\top \mathcal{M}^*)$  is approximately observable in infinite-time.*

The non-resonance condition (2.25) allows to guarantee the controllability of the original system (2.20). This condition is necessary in the context of finite-dimensional systems, see, e.g. [68]. In practice, the previous proposition corresponds to a controllability test for cascades of ODE-PDE systems of the form (2.20) in which  $\mathcal{S}$  is a skew-adjoint operator. The extension to more general classes of cascades PDE-PDE systems is still a missing result in literature.

As for the finite-dimensional case, since the first subsystem is already exponentially stable, we highlight that the proposed feedback law (2.23) can be also modified into

$$u = \varepsilon B^\top \mathcal{M}^* w$$

by selecting  $\varepsilon$  small enough. Furthermore, the proposed design can be also directly applied to the case of cascade in which the ODE is nonlinear and can be described as

$$\dot{z} = Az + B \text{sat}(u)$$

where  $\text{sat}$  is a generalized saturation function (e.g. any cone-bounded monotonic function), or by a Lipschitz system in the so-called normal form

$$\begin{aligned} \dot{x} &= f(x, e), & \xi &\in \mathbb{R}^\rho, \\ \dot{y} &= q(x, y) + u, & e &\in \mathbb{R}, \end{aligned}$$

with  $z = (x, y)$ , in which  $\xi$  represents some zero-dynamics which is incrementally ISS with respect to  $y$  and  $f(0, 0) = 0$ ,  $q(0, 0) = 0$ .

### 2.3.2 Scalar ODE coupled with a transport equation

As illustration of the previous results, we consider the cascade system composed by a scalar ODE and a PDE described by a conservative transport equation, that is, the following system

$$\begin{cases} \dot{z} = -az + u, & t \in \mathbb{R}_{\geq 0} \\ w_t(t, x) + \lambda w_x(t, x) = 0, & (t, x) \in \mathbb{R}_{\geq 0} \times [0, 1] \\ w(t, 0) = w(t, 1) + cz, & t \in \mathbb{R}_{\geq 0} \\ z(0) = z_0, w(0, x) = w_0(x), & x \in [0, 1], \end{cases} \quad (2.26)$$

with  $a, c$  and  $\lambda$  three positive constants. It can be noticed that the (autonomous) PDE is conservative, i.e. solution to

$$w_t(t, x) + \lambda w_x(t, x) = 0, \quad w(t, 0) = w(t, 1)$$

verifies

$$\frac{d}{dt} \int_0^1 w(t, x)^2 dx = 0.$$

In other words, the energy is constant in time. Note that this transport equation will play a fundamental role in the context of repetitive control (see Section 3.4) since the same equation represents the operator associated to a delay.

Following the approach developed in the previous section, we look for a solution  $\mathcal{M}$  to the Sylvester equation (2.22). In the context of system (2.26), it corresponds to look for an operator of the form

$$\mathcal{M}z := M(x)z$$

where  $M : [0, 1] \rightarrow \mathbb{R}$  is given as solution to

$$\begin{aligned} \lambda M'(x) &= aM(x), & x &\in [0, 1] \\ M(0) &= M(1) + c, \end{aligned}$$

and is explicitly computed as

$$M(x) = \frac{c}{1 - \exp\left(\frac{a}{\lambda}x\right)} \exp\left(\frac{a}{\lambda}x\right).$$

Furthermore, it can be verified that the pair  $(S, B^\top M^*)$  is observable according to Definition 2.6. In particular,  $M^*$  is explicitly given by

$$M^* : L^2(0, 1) \ni w \mapsto \int_0^1 M(x)w(x)dx \in \mathbb{R}.$$

Recalling that  $B^\top = 1$ , the equation  $B^\top M^* \mathbb{T}(t)w_0(x)$  for all  $t \geq 0$  reduces to  $\int_0^1 M(x)w(t, x)dx$ . With some computations, then, one can show that the system

$$\begin{aligned} w_t + \lambda w_x &= 0, & (t, x) &\in \mathbb{R}_{\geq 0} \times [0, 1], \\ w(t, 0) &= w(t, 1), & t &\in \mathbb{R}_{\geq 0} \\ w(0, x) &= w_0(x), & x &\in [0, 1] \\ y(t) &= \int_0^1 M(x)w(t, x)dx \end{aligned}$$

is approximately observable according to Definition 2.6. Since all the assumptions of Theorem 2.6 are verified, it can be shown that the feedback

$$u = -kz + \mu \int_0^1 M(x)(w(t, x) - M(x)z)dx$$

makes the origin of (2.26) asymptotically stable for any choice of  $k, \mu > 0$ .

## 2.4 Forwarding for PDE-ODE cascades

### 2.4.1 Exponentially Stable PDE and conservative ODE

In this section we consider the opposite problem of what is considered in Section 2.3. In other words, we consider a composite system composed of an exponentially stable PDE in cascade with a conservative ODE

$$\begin{aligned} \frac{d}{dt}x(t) &= \mathcal{A}x(t) + \mathcal{B}u(t), & x(0) &= x_0 \\ \frac{d}{dt}z(t) &= Sz(t) + G\mathcal{C}x(t), & z(0) &= z_0, \end{aligned} \tag{2.27}$$

where  $\mathcal{A} : D(\mathcal{A}) \subset \mathcal{X} \rightarrow \mathcal{X}$  with  $D(\mathcal{A})$  dense in  $\mathcal{X}$ ,  $\mathcal{B} \in \mathfrak{L}(\mathbb{R}^m, \mathcal{X})$ ,  $\mathcal{C} \in \mathfrak{L}(D(\mathcal{A}), \mathbb{R}^p)$ ,  $S \in \mathbb{R}^{r \times r}$ , and  $G \in \mathbb{R}^{r \times p}$ . The space  $D(\mathcal{A})$  is equipped with the usual graph norm. Therefore, the control operator  $\mathcal{B}$  is supposed to be bounded, while the output operator  $\mathcal{C}$  might be unbounded. Similar to the context of Section 2.3, we suppose that the first subsystem is already stable, while the second is conservative. This is formally stated in the following assumption.

**Assumption 2.2.** *The following statements hold.*

- *The operator  $\mathcal{A}$  generates a strongly continuous semigroup of contractions. Moreover, there exist a positive value  $\mu$  and a self-adjoint, positive and coercive operator  $\mathcal{P} \in \mathfrak{L}(\mathcal{X})$  such that, for every  $x \in D(\mathcal{A})$*

$$\langle \mathcal{P}\mathcal{A}x, x \rangle_{\mathcal{X}} + \langle \mathcal{P}x, \mathcal{A}x \rangle_{\mathcal{X}} \leq -\mu \|w\|_{\mathcal{X}}^2. \tag{2.28}$$

- *The pair  $(S, G)$  is controllable. Moreover there exists a symmetric positive definite matrix  $Q$  such that  $QS + S^\top Q \leq 0$ .*
- *The spectra of  $\mathcal{A}$  and  $S$  are disjoint and non-empty.*

Following the previous approach, we introduce the operator  $\mathcal{M} : \mathcal{X} \rightarrow \mathbb{R}^r$ , defined as the solution of the following Sylvester equation

$$\mathcal{M}\mathcal{A} = S\mathcal{M} + G\mathcal{C} \quad (2.29)$$

which is formally equivalent to (2.22). Invoking [153, Lemma 22], existence and uniqueness of the solution of the previous equation is guaranteed under previous assumption. Given such an operator  $\mathcal{M}$ , we can now design the feedback-law for the system (2.27). Furthermore, in order to provide a feedback law easy to implement, we look for an output-feedback design that uses only the  $z$  variable but not  $x$ . In particular, it is given by

$$u := \varepsilon \mathcal{B}^* \mathcal{M}^* Q z, \quad (2.30)$$

where  $Q$  is given by Assumption 2.2,  $\varepsilon$  is a positive constant to be chosen small enough. Denoting the state by  $\xi := (w, z)$  and the state space by  $\mathcal{H} := \mathcal{X} \times \mathbb{R}^r$ , the closed-loop system therefore reads

$$\frac{d}{dt}\xi = \mathcal{F}(\xi), \quad \xi(0) = \xi_0, \quad (2.31)$$

where

$$\mathcal{F}(\xi) = \begin{bmatrix} \mathcal{A} & \varepsilon \mathcal{B} \mathcal{B}^* \mathcal{M}^* Q \\ G\mathcal{C} & S \end{bmatrix},$$

with  $D(\mathcal{F}) := D(\mathcal{A}) \times \mathbb{R}^r$ . We have now the first theorem concerning the well-posedness of system (2.31).

**Theorem 2.7.** *Suppose Assumption 2.2 holds. Let us define  $\varepsilon^*$  as*

$$\varepsilon^* := \frac{\mu}{\|\mathcal{P}\|_{\mathcal{L}(\mathcal{X})} \|\mathcal{B}\|_{\mathcal{L}(\mathbb{R}^m, \mathcal{X})} \|\mathcal{M}\|_{\mathcal{L}(\mathcal{X}, \mathbb{R}^r)} |\mathcal{B}^* \mathcal{M}^*|} \max_{s \in (0,1)} \sqrt{\frac{1-s}{1+s}} s.$$

*For every  $\varepsilon \in (0, \varepsilon^*)$  and for every initial conditions  $(x_0, z_0) \in \mathcal{H}$  (resp.  $(x_0, z_0) \in D(\mathcal{F})$ ), there exists a unique solution  $(x, z) \in C(\mathbb{R}_{\geq 0}; \mathcal{H})$  (resp.  $(x, z) \in C^1(\mathbb{R}_{\geq 0}; D(\mathcal{F}))$ ) to (2.31).*

The previous theorem ensures the well posedness of the solutions of the system (2.27) in closed-loop with the feedback law (2.30), provided that the parameter  $\varepsilon$  is selected small enough. Similarly to the results of Section 2.4 In order to show the stability of the origin of the closed-loop system (2.31), the following extra assumption is needed.

**Theorem 2.8.** *Suppose Assumption 2.2 holds and moreover the pair  $(S, \mathcal{B}^* \mathcal{M}^* Q)$  is detectable<sup>3</sup>. Then with  $\varepsilon^*$  defined in Theorem 2.7, for every  $\varepsilon \in (0, \varepsilon^*)$  and for every initial conditions,  $(x_0, z_0) \in \mathcal{H}$ , the origin of (2.31) is globally exponentially stable.*

Note that the detectability of the pair  $(S, \mathcal{B}^* \mathcal{M}^* Q)$  can be directly checked provided that one is able to solve the Sylvester equation (2.29), whose solution is anyway needed in order to design the feedback law (2.30). Although such an observability condition is directly related to the data of the problem (i.e. the operators  $\mathcal{A}, \mathcal{B}, \mathcal{C}$  and the matrices  $S, G$ ) via the Sylvester equation (2.29), one may ask whether alternative conditions can be established, similarly to the result of Proposition 2.7. An answer is given in the case in which the matrix  $S$  is skew-symmetric, i.e. when  $Q$  in Assumption 2.2 coincides with the identity matrix. Note that this can be always satisfied via a preliminary change of coordinates  $z \mapsto Q^{\frac{1}{2}} z$ . In such a case, we have the following result.

---

<sup>3</sup>In other words, there exists  $L$  such that the matrix  $(S - L\mathcal{B}^* \mathcal{M}^* Q)$  is Hurwitz.

**Proposition 2.8.** *Suppose that  $S$  is a skew-symmetric matrix and that the following holds*

$$\text{Ran} \begin{bmatrix} \mathcal{A} - I_X \lambda & \mathcal{B} \\ \mathcal{C} & 0 \end{bmatrix} = \mathcal{X} \times \mathbb{R}^p \quad (2.32)$$

for any  $\lambda$  eigenvalue of  $S$ . Then, the pair  $(S, \mathcal{B}^* \mathcal{M}^*)$  is observable.

### 2.4.2 Korteweg-de Vries equation coupled with an integrator

Following the previous idea of forwarding for cascade systems, we study now the problem of stabilizing a cascade composed by a KdV equation with an integrator. In particular, we study the following system

$$\begin{cases} w_t(t, x) + w_x(t, x) + w_{xxx}(t, x) = 0, & (t, x) \in \mathbb{R}_{\geq 0} \times [0, L], \\ w(t, 0) = w(t, L) = 0 & t \in \mathbb{R}_{\geq 0}, \\ w_x(t, L) = u(t), & t \in \mathbb{R}_{\geq 0}, \\ w(0, x) = w_0(x). & x \in [0, L], \\ \dot{z}(t) = w_x(t, 0). \end{cases} \quad (2.33)$$

We can compactly rewrite system (2.33), in the form (2.27) by selecting

$$\begin{aligned} \mathcal{A}w &= -w' - w''', & \mathcal{B}^*w &= w_x(L), & \mathcal{C}w &= w_x(0), \\ D(\mathcal{A}) &= \{w \in H^3(0, L) : w(0) = w(L) = w'(L) = 0\}, \\ S &= 0, & G &= 1, \end{aligned} \quad (2.34)$$

and it can be noted that  $\mathcal{B}$  (obtained from the definition of  $\mathcal{B}^*$ ) is an unbounded operator. As a consequence, we cannot apply directly Theorem (2.8). Nevertheless, we can follow the same reasoning to obtain a similar feedback law and study the overall closed-loop system. To this end, we define the operator  $\mathcal{M} : L^2(0, L) \rightarrow \mathbb{R}$  as solution to the following Sylvester equation

$$\mathcal{M}\mathcal{A}w = \mathcal{C}w, \quad \forall w \in D(\mathcal{A}). \quad (2.35)$$

Since the strongly continuous semigroup generated by the operator  $\mathcal{A}$  is exponentially stable, the Sylvester equation (2.35) admits a unique solution, see [153, Lemma 22]. Moreover, since  $\mathcal{M}$  is a linear form, according to Riesz representation theorem [40, Theorem 4.11], the operator  $\mathcal{M}$  is uniquely defined as

$$\mathcal{M}w = \int_0^L M(x)w(x)dx.$$

In order to obtain an explicit solution, we write equation (2.35) in the explicit form

$$w'(0) = - \int_0^L M(x)[w'(x) + w'''(x)]dx \quad \forall w \in D(\mathcal{A}).$$

Using integration by parts we obtain

$$w'(0) = \int_0^L w(x)[M'(x) + M'''(x)]dx + M(0)w''(0) - M(L)w''(L) - M'(0)w'(0),$$

for all  $w \in D(\mathcal{S})$ . From the latter equation, we obtain the following boundary value problem

$$\begin{cases} M''' + M' = 0, \\ M(0) = M(L) = 0, \\ M'(0) = -1. \end{cases} \quad (2.36)$$



It can be verified that the function

$$M : x \in \mathbb{R} \mapsto \frac{-2 \sin(\frac{x}{2}) \sin(\frac{L-x}{2})}{\sin(\frac{L}{2})} \quad (2.37)$$

is a solution to (2.36). Then, using the definition of  $\mathcal{B}^*$ , we can compute  $\mathcal{B}^* \mathcal{M}^*$  as

$$\mathcal{B}^* \mathcal{M}^* = \frac{dM(x)}{dx} M(L) = -1$$

Finally, following (2.30) and selecting  $Q = 1$ , we obtain a feedback law of the form  $u = kz$  with  $k \in (0, k^*)$  to be chosen small enough, with  $k^* = \varepsilon^* \mathcal{B}^* \mathcal{M}^*$ , and  $\varepsilon^*$  given by Theorem 2.7. In particular, we obtain simply  $u = -\varepsilon z$ .

### 2.4.3 Heat equation coupled with a linear oscillator

We consider, as illustration, the case of a linear system controlled via an actuator with dynamics described by a heat equation [119]. In particular, for a positive integer  $r$  and  $(w_0, z_0)$  in  $L^2(0, 1) \times \mathbb{R}^r$ , we consider the following system

$$\begin{aligned} w_t(t, x) - w_{xx}(t, x) &= b(x)u(t), & (t, x) \in \mathbb{R}_{\geq 0} \times (0, 1), \\ \dot{z}(t) &= Sz(t) + Gw(t, \ell), & t \in \mathbb{R}_{\geq 0}, \\ w(t, 0) = w(t, 1) &= 0, & t \in \mathbb{R}_{\geq 0}, \\ (w(0, x), z(0)) &= (w_0(x), z_0), & x \in (0, 1), \end{aligned} \quad (2.38)$$

where  $b$  is in  $L^2(0, 1)$  and  $\ell$  in  $(0, 1)$  and with  $S = -S^\top$  in  $\mathbb{R}^{r \times r}$  and  $G$  in  $\mathbb{R}^r$  such that the pair  $(S, G)$  is controllable. This system can be written in the form (2.27) by setting  $\mathcal{X} := L^2(0, 1)$  and

$$\mathcal{A}w := w'', \quad \mathcal{B}u := bu, \quad \mathcal{C}w := w(\ell),$$

with  $D(\mathcal{A}) := \{w \in H^2(0, 1) : w(0) = w(1) = 0\}$ . It can be verified that Assumption 2.2 is satisfied. In particular, by selectin  $P = I_{\mathcal{X}}$ , it can be shown that

$$\langle \mathcal{A}w, w \rangle_{\mathcal{X}} + \langle w, \mathcal{A}w \rangle_{\mathcal{X}} = -\|w'\|_{\mathcal{X}}^2.$$

for any  $w \in D(\mathcal{A})$ . Using the Poincaré inequality, inequality (2.28) follows with  $\mu = \pi$ . Moreover, since  $S$  is skew adjoint, its eigenvalues are on the imaginary axis, then the spectrum of  $\mathcal{A}$  and  $S$  is disjoint since  $\mathcal{A}$  contains eigenvalues at the left hand side of the imaginary axis.

To apply the control law (2.30), we look for an operator  $\mathcal{M} : L^2(0, 1) \rightarrow \mathbb{R}^r$  solution to the Sylvester equation (2.29) which in our context becomes

$$\mathcal{M}w'' = S\mathcal{M}w + Gw(\ell), \quad \forall w \in D(\mathcal{A}).$$

Moreover,  $\mathcal{M}$  can be looked as an operator in integral form, i.e.

$$\mathcal{M}w = \int_0^1 M(x)w(x)dx,$$

where  $M : [0, 1] \mapsto \mathbb{R}^r$  is defined as

$$M(x) = \begin{cases} E_1 \exp(Fx)N_0, & x \in (0, \ell) \\ E_1 \exp(Fx)N_0 + E_1 \exp(F(x - \ell))\Gamma, & x \in (\ell, 1) \end{cases}$$

where  $(F, G, N_0, E_1)$  are matrices respectively in  $\mathbb{R}^{2r \times 2r}$ ,  $\mathbb{R}^{2r}$ ,  $\mathbb{R}^{2r}$  and  $\mathbb{R}^{r \times 2r}$  defined as

$$F = \begin{bmatrix} 0 & I_r \\ S & 0 \end{bmatrix}, \quad \Gamma = \begin{bmatrix} 0 \\ G \end{bmatrix}, \quad E_1 = \begin{bmatrix} I_r & 0 \end{bmatrix},$$

and

$$N_0 = - \left( \begin{bmatrix} E_1 & \\ E_1 \exp(F) \end{bmatrix} \right)^{-1} \begin{bmatrix} 0 \\ -E_1 \exp(F(1-\ell))\Gamma \end{bmatrix}.$$

The forwarding control feedback (2.30) takes therefore the form

$$u(t) = -\varepsilon \left( \int_0^1 M(x)b(x)dx \right)^\top z(t).$$

Consider moreover the simple case in which  $r = 2$  and  $S, G$  are given by

$$S := \begin{bmatrix} 0 & 1 \\ -1 & 0 \end{bmatrix}, \quad G := \begin{bmatrix} 1 & 0 \end{bmatrix}.$$

Due to the particular structure of the matrix  $S$ , the pair  $(S, \mathcal{B}^* \mathcal{M}^*)$  is observable if and only if  $\mathcal{B}^* \mathcal{M}^* \neq 0$ . Hence, if

$$\int_0^1 M(x)b(x)dx \neq 0,$$

exponential stability of the closed-loop system is guaranteed.

## 2.5 Integral action control for PDEs

In this section we investigate the use of integral action controllers for infinite-dimensional systems, see, e.g. [62, 127, 128, 155, 199]. First, we provide a new result in the context of anti-windup design (see, e.g. [93, 101, 173, 195]) for abstract operators. Then, we focus on the use of integral action for the Korteweg-de Vries equation.

### 2.5.1 Anti-windup for linear abstract operators

In this section we consider a class of controlled linear systems with saturated control. In particular, we consider  $\mathcal{X}$  as a Hilbert space equipped with a norm  $\|\cdot\|_{\mathcal{X}}$  and a scalar product  $\langle \cdot, \cdot \rangle_{\mathcal{X}}$ . We consider systems which are described as

$$\frac{d}{dt}x = \mathcal{A}x + \mathcal{B} \text{sat}_L(u) + d, \quad y = \mathcal{C}x, \quad (2.39)$$

in which  $\mathcal{A} : D(\mathcal{A}) \subset \mathcal{X} \rightarrow \mathcal{X}$  is an infinitesimal generator of a  $C_0$ -semigroup denoted  $t \mapsto e^{t\mathcal{A}}$ , the operator  $\mathcal{B} \in \mathfrak{L}(\mathbb{R}, \mathcal{X})$  is linear and bounded, the operator  $\mathcal{C}$  is in<sup>4</sup>  $\mathfrak{L}(D(\mathcal{A}), \mathbb{R})$ ,  $u$  in  $\mathbb{R}$  is the control input,  $y$  in  $\mathbb{R}$  is the measured output,  $d$  in  $\mathcal{X}$  is an unknown constant disturbance vector, and the saturation function  $\text{sat}_L$  is defined as

$$\text{sat}_L(s) := \begin{cases} L & \text{if } s \geq L, \\ s & \text{if } |s| \leq L, \\ -L & \text{if } s \leq -L, \end{cases} \quad (2.40)$$

<sup>4</sup>Since  $\mathcal{A}$  is an infinitesimal generator of a  $C_0$ -semigroup, its domain  $D(\mathcal{A})$  is a Hilbert space equipped with the graph norm  $\|x\|_{D(\mathcal{A})} = \|x\|_{\mathcal{X}} + \|\mathcal{A}x\|_{\mathcal{X}}$ .

for some  $L > 0$ . Given a constant reference  $y_{\text{ref}} \in \mathbb{R}$ , we are interested in the design of a feedback law for system (2.39) so that there exists a unique equilibrium which is exponentially stable and

$$\lim_{t \rightarrow \infty} y(t) = y_{\text{ref}}, \quad (2.41)$$

by means of an integral action. Note that the regulation problem could be defined without requiring existence and uniqueness of equilibrium leading to weaker assumptions. We state now the following set of assumptions, similarly to [199].

**Assumption 2.3.** *The operator  $\mathcal{A}$  generates a strongly continuous semigroup  $(e^{t\mathcal{A}})_{t \geq 0}$ , and moreover there exist a coercive and self-adjoint operator  $\mathcal{Q} \in \mathfrak{L}(X)$  and a positive constant  $\nu$  such that for all  $x \in D(\mathcal{A})$*

$$\langle \mathcal{A}x, \mathcal{Q}x \rangle_{\mathcal{X}} + \langle \mathcal{Q}x, \mathcal{A}x \rangle_{\mathcal{X}} \leq -2\nu \|x\|_{\mathcal{X}}^2. \quad (2.42)$$

Then, following [155], we assume (up to a reparametrization) the following.

**Assumption 2.4.** *The condition  $\mathcal{C}\mathcal{A}^{-1}\mathcal{B} = 1$  holds.*

Assumption 2.3 establishes that the semigroup generated by  $\mathcal{A}$  is exponentially stable. It can be shown that in order to achieve exponential stability this assumption is necessary, see of Proposition 2.2. Note that exponential stability could be obtained without assuming coercivity of the operator  $\mathcal{Q}$ . However, it is not straightforward to obtain exponential stability for the closed loop system that we study, because it is nonlinear due to the saturation operator. Following [143], it may be possible to remove this coercivity assumption.

Assumption 2.4 could be also relaxed as  $\mathcal{C}\mathcal{A}^{-1}\mathcal{B} \neq 0$ , corresponding to the classical non-resonance condition (see, e.g., [D25] for the finite-dimensional case and [199] for the infinite-dimensional case). Here we select its value set to 1 to ease the rest of the presentation.

Following classical finite-dimensional strategies, we extend the system (2.39) with an integral action [D25] and an anti-windup mechanism [93, 101, 173, 195]. In particular, we propose the following regulator

$$\frac{d}{dt}z = \mathcal{C}x - y_{\text{ref}} - \mu \text{dz}_L(u), \quad u = kz, \quad (2.43)$$

with  $z$  in  $\mathbb{R}$ ,  $\mu, k$  positive parameters to be selected so that to ensure the solutions to the closed-loop system (2.39), (2.43) to be exponentially stable, and the dead zone function  $\text{dz}$  defined as

$$\text{dz}_L(s) := s - \text{sat}_L(s).$$

In view of the definition of the dead zone function, the extended closed-loop system (2.39), (2.43) reads as

$$\xi = \begin{pmatrix} x \\ z \end{pmatrix}, \quad \frac{d}{dt}\xi = \mathcal{F}\xi + \mathcal{G} \text{sat}_L(\mathcal{K}\xi) + \Gamma, \quad (2.44)$$

with  $\mathcal{F}, \mathcal{G}, \mathcal{K}$  defined as

$$\mathcal{F} := \begin{pmatrix} \mathcal{A} & 0 \\ \mathcal{C} & -\mu k \end{pmatrix}, \quad \mathcal{G} = \begin{pmatrix} \mathcal{B} \\ \mu \end{pmatrix}, \quad \mathcal{K} = \begin{pmatrix} 0 & k \end{pmatrix},$$

and  $\Gamma = (d, y_{\text{ref}})$ . The state space is defined by  $\mathcal{H} = \mathcal{X} \times \mathbb{R}$  and it is equipped with the norm

$$\|\xi\|_{\mathcal{H}} = \|(x, z)\|_{\mathcal{H}} = \sqrt{\langle x, x \rangle_{\mathcal{X}} + |z|^2}$$

with the associated scalar product  $\langle (x_1, z_1), (x_2, z_2) \rangle_{\mathcal{H}} = \langle x, x \rangle_{\mathcal{X}} + z_1 z_2$ . Moreover, we define the domain of the operator  $\mathcal{F}$  given by

$$D(\mathcal{F}) = \{(x, z) \in \mathcal{X} \times \mathbb{R} : \mathcal{A}x \in \mathcal{X}\}$$

which is equipped with the usual graph norm.

The following result ensures that there exists a unique equilibrium point to the closed-loop system (2.44). This existence result relies mainly on Assumption 2.4. In addition to this existence, we provide a condition ensuring that, if the perturbation  $d$  and the reference  $y_{\text{ref}}$  are sufficiently small, then at the equilibrium the regulation objective  $\mathcal{C}x^\circ = y_{\text{ref}}$  is satisfied, despite the perturbation  $d$ .

**Lemma 2.1.** *There exists a unique equilibrium point  $(x^\circ, z^\circ) \in D(\mathcal{F})$  to (2.44). In other words, there exists a unique solution  $(x^\circ, z^\circ) \in D(\mathcal{F})$  to the following set of equations:*

$$\begin{aligned} 0 &= \mathcal{A}x^\circ + \mathcal{B} \text{sat}_L(kz^\circ) + d \\ 0 &= \mathcal{C}x^\circ - y_{\text{ref}} - \mu \text{dz}_L(kz^\circ). \end{aligned}$$

Moreover, let  $\Omega \subset \mathcal{X} \times \mathbb{R}$  be defined as

$$\Omega = \{(d, y_{\text{ref}}) \in \mathcal{X} \times \mathbb{R} : |\mathcal{C}\mathcal{A}^{-1}d + y_{\text{ref}}| \leq L\}.$$

Then, for all  $(d, y_{\text{ref}}) \in \Omega$ , one has  $\mathcal{C}x^\circ = y_{\text{ref}}$ .

Given a nominal value  $(d, y_{\text{ref}})$  and its corresponding nominal equilibrium  $(x^\circ, z^\circ)$  established by the previous lemma, we consider now the change of coordinates

$$\xi \mapsto \tilde{\xi} := \xi - \xi^\circ = \begin{pmatrix} x - x^\circ \\ z - z^\circ \end{pmatrix}.$$

The system (2.44) reads in these new coordinates:

$$\begin{aligned} \frac{d}{dt} \tilde{x} &= \mathcal{A}\tilde{x} + \mathcal{B}[\text{sat}_L(k\tilde{z} + kz^\circ) - \text{sat}_L(kz^\circ)] \\ \frac{d}{dt} \tilde{z} &= \mathcal{C}x - \mu[\text{dz}_L(k\tilde{z} + kz^\circ) - \text{dz}_L(kz^\circ)] \end{aligned}$$

or equivalently,

$$\frac{d}{dt} \tilde{x} = \mathcal{F}\tilde{x} + \mathcal{G}\psi_L(\mathcal{K}\tilde{x}), \quad \psi_L(\mathcal{K}\tilde{x}) := \text{sat}_L(\mathcal{K}(\tilde{x} + x^\circ)) - \text{sat}_L(\mathcal{K}x^\circ). \quad (2.45)$$

System (2.45) is a semi-linear system of the form (2.5) considered in Section 2.2 and moreover the function  $\psi_L$  so defined satisfies Definition 2.7 of generalized saturation (picking  $2L$  instead of  $L$ ). Well-posedness of system (2.45) follows from direct application of Proposition 2.1.

As a consequence, our aim is to show that an appropriate selection of the parameters  $\mu, k$  allows to apply Proposition 2.4 in order to show that the origin of system (2.45) is globally exponentially stable. To this end, we need to introduce a new operator that will be denoted as  $\mathcal{M}$ . In particular, since  $\mathcal{A}$  generates a strongly continuous semigroup which origin is exponentially stable, it admits an inverse,  $\mathcal{A}^{-1}$  which belongs to  $\mathcal{L}(\mathcal{X}, D(\mathcal{A}))$  (see e.g., [57, Theo. 2.1]). As a consequence,  $\mathcal{C}$  being  $\mathcal{A}$ -bounded, the operator  $\mathcal{M} = \mathcal{C}\mathcal{A}^{-1}$  belongs to  $\mathcal{L}(\mathcal{X}, \mathbb{R})$ . Note that such an operator  $\mathcal{M}$  is solution to the following equation

$$\mathcal{M}\mathcal{A}x = \mathcal{C}x \quad \forall x \in D(\mathcal{A}). \quad (2.46)$$

We have now the following result.

**Proposition 2.9.** *Suppose Assumption 2.3 and 2.4 hold. For any  $\mu > 0$  and  $k \in (0, k^*)$  with  $k^*$  given by*

$$k^* = \min \left\{ \frac{\nu}{\mu \|\mathcal{M}\|_{\mathfrak{L}(\mathcal{X}, \mathbb{R})}^2}, \frac{\nu}{\|(\mathcal{Q} + \mathcal{M}^* \mathcal{M})\mathcal{B}\|_{\mathfrak{L}(\mathcal{X}, \mathbb{R})}^2} \right\}, \quad (2.47)$$

the origin of (2.45) is globally exponentially stable.

The main idea of the proof of this proposition consists in showing the existence of a common Lyapunov functional for the operators  $\mathcal{F}$  and for  $\mathcal{F} + \mathcal{G}\mathcal{K}$ , which is the context of Proposition 2.4. Such an operator is given by

$$\mathcal{P}(x, z) = \begin{pmatrix} \mathcal{Q} + \mathcal{M}^* \mathcal{M} & -\mathcal{M}^* \\ \mathcal{M} & 1 \end{pmatrix} \begin{pmatrix} x \\ z \end{pmatrix}, \quad (2.48)$$

and it is based on the forwarding approach given in Section 2.4.1.

Note that from condition (2.47) we obtain that if

$$\mu \in \left( 0, \frac{\|(\mathcal{Q} + \mathcal{M}^* \mathcal{M})\mathcal{B}\|_{\mathfrak{L}(\mathcal{X}, \mathbb{R})}^2}{\|\mathcal{M}\|_{\mathfrak{L}(\mathcal{X}, \mathbb{R})}^2} \right)$$

then  $k^*$  is independent of  $\mu$ , allowing for a larger interval for the choice of  $k$ .

Finally, in view of the previous result, we state the following result which combines the result of Proposition 2.9 with the properties of the equilibria of the closed-loop dynamics established in Lemma 2.1. In summary, global exponential set-point regulation by means of an integral action in the presence of input saturation is obtained, thanks to the anti wind-up design of the regulator (2.43).

**Theorem 2.9.** *Consider system (2.39) and suppose Assumption 2.3 and 2.4 hold. Consider the controller (2.43) and select  $\mu, k$  according to Proposition 2.9. For any  $d, y_{\text{ref}} \in \Omega$ , with  $\Omega$  defined in Lemma 2.1, the closed-loop system (2.39), (2.43) admits a unique equilibrium  $(x^\circ, z^\circ)$  which is globally exponentially stable and satisfies  $y = Cx^\circ = y_{\text{ref}}$ .*

## 2.5.2 Integral action for the Korteweg-de Vries equation

Consider the Korteweg-de Vries equation introduced in Section 2.2.3 and in particular the following linear model

$$\begin{cases} w_t(t, x) + w_x(t, x) + w_{xxx}(t, x) = d(x), & (t, x) \in \mathbb{R}_{\geq 0} \times [0, L] \\ w(t, 0) = w(t, L) = 0, & t \in \mathbb{R}_{\geq 0} \\ w_x(t, L) = u(t), & t \in \mathbb{R}_{\geq 0} \\ w(0, x) = w_0(x), & x \in [0, L] \\ y(t) = w_x(t, 0) & t \in \mathbb{R}_{\geq 0} \end{cases} \quad (2.49)$$

in which  $w \in L^2(0, L)$  is the state, with  $L > 0$ ,  $L \notin \mathcal{N}$ , with  $\mathcal{N}$  defined in (2.16),  $u \in \mathbb{R}$  is the control input acting on the boundary conditions,  $d$  is a constant (unknown) distributed perturbation, and  $y \in \mathbb{R}$  is the output to be regulated to a desired constant value  $y_{\text{ref}}$ , namely

$$\lim_{t \rightarrow \infty} |y(t) - y_{\text{ref}}| = 0. \quad (2.50)$$

Following the idea of adding an integral action, we consider here the regulator

$$\begin{aligned} \dot{z}(t) &= y(t) - y_{\text{ref}} = w_x(t, 0) - y_{\text{ref}} \\ u(t) &= kz(t) \end{aligned} \quad (2.51)$$

where  $k > 0$  is a positive parameter to be chosen. We define the space  $\mathcal{H} := L^2(0, L) \times \mathbb{R}$ , that is the state space of the closed-loop system (2.49), (2.51). It is a Hilbert space as the Cartesian product of two Hilbert spaces. Furthermore, following the notation introduced in Section 2.4.2, the overall closed-loop system (2.49), (2.51) can be written in a compact notation as

$$\frac{d}{dt}\xi = \mathcal{F}\xi + \Gamma, \quad \xi = \begin{pmatrix} w \\ z \end{pmatrix}, \quad \mathcal{F}\xi = \begin{pmatrix} -w' - w''' \\ w'(0) \end{pmatrix}, \quad \Gamma = \begin{pmatrix} d \\ -y_{\text{ref}} \end{pmatrix} \quad (2.52)$$

with the domain of  $\mathcal{F}$  defined as

$$D(\mathcal{F}) := \{(w, z) \in H^3(0, L) \times \mathbb{R} : w(0) = w(L) = 0, w'(L) = kz\} \subset \mathcal{H}.$$

We can now show that the closed-loop system (2.52) is well posed, it admits a unique equilibrium which is exponentially stable, and the regulation objective (2.50) is achieved when considering sufficiently regular solutions.

**Lemma 2.2.** *For any  $k \neq 0$  and  $(d, y_{\text{ref}}) \in L^2(0, L) \times \mathbb{R}$  there exist a unique equilibrium state  $(w_\infty, z_\infty) \in \mathcal{H}$  to (2.52).*

Next, we show the following well-posedness result for the closed-loop system (2.52).

**Lemma 2.3.** *Let  $L \notin \mathcal{N}$ , with  $\mathcal{N}$  defined in (2.16). There exist  $k^* > 0$  such that for any  $k \in (0, k^*)$ , for any  $(d, y_{\text{ref}}) \in L^2(0, L) \times \mathbb{R}$  and for any initial condition  $(w_0, z_0) \in \mathcal{H}$  (resp.  $D(\mathcal{F})$ ), there exists a unique weak solution  $(w, z) \in C^0(\mathbb{R}_{\geq 0}; \mathcal{H})$  (resp. strong solution in  $C^1(\mathbb{R}_{\geq 0}; \mathcal{H}) \cap C^0(\mathbb{R}_{\geq 0}; D(\mathcal{F}))$ ) to system (2.52).*

Note that the proof of the previous lemma is based on the strict Lyapunov functional that we studied in Section 2.2.3. We have the following result.

**Theorem 2.10.** *Let  $L \notin \mathcal{N}$ , with  $\mathcal{N}$  defined in (2.16). For any  $k \in (0, k^*)$ , with  $k^*$  given by Lemma 2.3, there exist  $b, \nu > 0$ , and for any  $(d, y_{\text{ref}}) \in L^2(0, L) \times \mathbb{R}$  there exists  $\xi_\infty \in \mathcal{H}$ , computed according to Lemma 2.2, such that any solution to system (2.52) with initial condition  $\xi_0 \in \mathcal{H}$  satisfies*

$$\|\xi(t) - \xi_\infty\|_{\mathcal{H}} \leq b e^{-\nu t} \|\xi_0 - \xi_\infty\|_{\mathcal{H}}. \quad (2.53)$$

for all  $t \geq 0$ . Moreover, for any strong solution to (2.52), and in particular, for any  $\xi_0 \in D(\mathcal{F})$ , the output  $y$  is asymptotically regulated at the reference  $y_{\text{ref}}$ , namely (2.50) is satisfied.

Note that the value of  $k^*$  can be computed following for instance Section 2.4.2.

Finally, thanks to the local ISS-properties of the nonlinear model studied in Section 2.2.3, we can also show that the integral action regulator (2.51) is able to guarantee local regulation for a nonlinear KdV equation of the form

$$\begin{cases} w_t(t, x) + w_x(t, x) + w_{xxx}(t, x) + w(t, x)w_x(t, x) = d(x), & (t, x) \in \mathbb{R}_{\geq 0} \times [0, L] \\ w(t, 0) = w(t, L) = 0, & t \in \mathbb{R}_{\geq 0} \\ w_x(t, L) = u(t), & t \in \mathbb{R}_{\geq 0} \\ w(0, x) = w_0(x), & x \in [0, L] \\ y(t) = w_x(t, 0) & t \in \mathbb{R}_{\geq 0}. \end{cases} \quad (2.54)$$

In this case, locality has to be intended in both initial conditions and size of the perturbations/references. In particular, we have the following result.

**Theorem 2.11.** Consider the system (2.54) in closed-loop with (2.51) and suppose  $L \notin \mathcal{N}$ , with  $\mathcal{N}$  defined in (2.16). There exists  $\delta$  and  $k^*$  such that, if

$$\|w_0\|_{H^3(0,L)} + |z(0)| + \|d\|_{L^2(0,L)} + |y_{\text{ref}}| \leq \delta$$

then, for any  $k \in (0, k^*)$ , the following properties hold.

- The closed-loop system (2.54), (2.51) admits an equilibrium  $(w_\infty, z_\infty) \in H^3(0, L) \times \mathbb{R}$ .
- For any initial condition  $(w_0, z_0) \in D(\mathcal{F})$  satisfying the previous condition the Cauchy problem (2.54), (2.51) is well-posed in the space  $C^1(0, \mathbb{R}_{\geq 0}) \times (C([0, \mathbb{R}_{\geq 0}]; H^3(0, L)) \cap L^2([0, \mathbb{R}_{\geq 0}]; H^4(0, L)))$  and satisfies

$$\|(w(t), z(t)) - (w_\infty, z_\infty)\|_{\mathcal{H}} \leq b e^{-\nu t} \delta \quad \forall t \geq 0$$

for some  $b, \nu > 0$ .

- The output  $y$  is asymptotically regulated at the reference  $y_{\text{ref}}$ , namely (2.50) is satisfied.

## 2.6 Conclusions and perspectives

In this chapter we studied the stability and stabilization of some PDEs and PDEs-ODEs couplings. Some sufficient and necessary conditions for the stability of some semi-linear systems have been studied. These results have been published in [D29]. Then, inspired from the finite-dimensional nonlinear systems literature, we proposed a tool for the strictification of Lyapunov functions, which has been directly applied to the context of Korteweg-de-Vries equation, see [D32]. Finally, we developed the forwarding approach in the context of ODE-PDE couplings. First, we studied the case in which a stable ODE is put in cascade with a possibly conservative PDE, see [D52, D53]. This tool will be used in the context of output regulation and infinite-dimensional internal-model based regulators (see [D19]) in Section 3.4. Then, we studied the stabilization of an exponentially stable PDE in cascade with a conservative ODE (see [D51]), as in the case of integral action feedback developed in the subsequent Section 2.5, based on the publications [D18, D32].

Further extension includes the developments of the forwarding approach in the context of more complex nonlinear PDEs, combining for instance the sufficient and necessary conditions developed for semi-linear PDEs of Section 2.2. Note that inspired by the series of works [D25, D48, D53] some preliminary results in this direction has been recently obtained in [206]. Finally, the problem of output regulation of nonlinear abstract operators in the presence of more complex disturbances/references is also an open problem.

# 3

## Nonlinear output regulation

---

### Contents

---

<b>3.1 The problem of robustness in output regulation</b> . . . . .	<b>51</b>
3.1.1 Systems, limit sets and steady-state properties . . . . .	52
3.1.2 Characterization of perturbations . . . . .	54
3.1.3 Definition of a robust regulator . . . . .	55
<b>3.2 Regulators with linear internal models</b> . . . . .	<b>57</b>
3.2.1 Internal model design . . . . .	57
3.2.2 Asymptotic regulation . . . . .	57
3.2.3 Harmonic regulation . . . . .	60
3.2.4 Stabilizer design . . . . .	65
<b>3.3 Nonlinear internal models</b> . . . . .	<b>71</b>
3.3.1 Asymptotic regulation via nonlinear internal models . . . . .	71
3.3.2 $C^0$ -robust regulators are linear . . . . .	72
3.3.3 Non-asymptotic properties of finite-dimensional linear regulators . . . . .	74
<b>3.4 Infinite-dimensional internal model regulators</b> . . . . .	<b>75</b>
3.4.1 Internal model design . . . . .	75
3.4.2 Finite-dimensional approximation . . . . .	80
<b>3.5 Conclusions and perspectives</b> . . . . .	<b>83</b>

---

The problem of rejecting or tracking asymptotically periodic<sup>1</sup> signals is of primary importance in many applications [122, 131, 211]. Among them, robotics [112, 147], power electronics [34, 140] and bio-medics engineering [85, 171], just to cite few. Such a problem is commonly known in control system theory as *robust output regulation*, see [47, 67, 83], where the adjective robust refers, in this context, to the fact that the asymptotic properties are desired to hold not only for the nominal model of the system, but also for small perturbations of it. The solution to the robust output regulation problem for finite-dimensional linear time-invariant systems is accredited to Francis, Wonham and Davison who at the same time, but independently, published their main works during the 70's, see, e.g., [67, 83]. The proposed solution relies on the so-called *internal model principle* coined by Francis and Wonham in their celebrated work [83], stating that output regulation property is insensitive to plant parameter variations “only if the controller utilizes feedback of the regulated variable, and incorporates in the feedback path a

---

<sup>1</sup>or more general stationary signals having a well defined auto-correlation in the means-square sense.



suitably reduplicated model of the dynamic structure of the exogenous signals which the regulator is required to process". In turns, if some overall stability properties are guaranteed, the presence of a copy of the exogenous dynamics (also denoted as exosystem) in the regulator provides a "blocking-zero" effect on the desired regulated output at the dynamics excited by such exogenous signals. In other words, the regulated output cannot contain any mode of the exosystem if the overall trajectories are bounded. In practice, an integral action in the controller allows to achieve zero-DC value of the regulated error, while a given oscillator at a certain frequency, ensures the output to have zero spectral component at it [D26].

Afterwards, since the end of the 70's, three main families of approaches have been investigated to address the problem of robust output regulation in the context of nonlinear systems: internal-model designs (trying to extend the linear paradigm), repetitive control, and non-smooth regulators based on finite-time convergence. Concerning the last class of regulators, we recall, among others, the approaches based on sliding-mode controllers [144,205] and time-varying regulators [188]. However, since these techniques are in general non-robust with respect to measurement noise and may suffer of implementations issues such as chattering or unbounded variables, we don't consider such type of designs in this work, and we focus instead on the first two families of approaches.

From an historical point of view, after the statement of the internal model principle for linear systems [83], the direct extension to nonlinear systems encountered many difficulties, due to crucial observation that "internal models must not only be able to generate inputs corresponding to the trajectories of the system, but also a number of higher order nonlinear deformations", see [103,113,161]. Inspired by such remark, from the end of the 80's, many researchers addressed the output regulation problem from the "control input viewpoint", that is, trying to build internal model controllers able to generate all possible steady-state inputs required to constantly keep the regulated output equal to zero, with in mind the different type of nonlinearities characterizing the nominal model of the system. Starting from simple polynomial constructions [103,161], more sophisticated designs were successively proposed, based on linear immersion approaches [45,114]; adaptive techniques [1,183]; observer designs [46,137]; nonlinear regressions [82]; identification techniques [33]. All these works were mainly motivated by the sought for a finite-dimensional regulator endowed with good asymptotic properties. However, although robustness to parametric perturbations may be still ensured in some particular cases (see for instance [33,183]), asymptotic properties are in general not preserved when allowing any type of (nonlinear) model deformation, as we shall prove in this chapter. From this point of view, only integral controllers are "universally robust" to any type of (time-invariant)  $C^1$  deformations in presence of constant perturbations/references, as shown in [156], [D25]. These robustness issues motivate also for approximate or practical regulation objectives, see for instance recent works [31,105,135,136], [D26].

In parallel to the previous line of research, an alternative approach, denoted as *repetitive control*, was independently developed at the end of the 80's, see [97,147]. Inspired by the internal model principle, such approach paved his way on the observation that a delay system may be viewed as a universal generator, i.e. an internal model, of periodic signals. Repetitive control developed his own research domain by the use of delay in the feedback regulator and based its theoretical foundation in the context of continuous-time linear systems with a stability analysis that relies on frequency-domain and Nyquist criterion approaches [97], although alternative proofs have been proposed by means of passive arguments to extend the theory to nonlinear systems, see for instance [51]. Since only systems with zero-relative degree [51,97] can be stabilized in presence of a delay in the loop, researchers devoted its attention to finite-time implementations in order to extend the classes of systems to which a repetitive-control scheme can

be applied. When considering continuous-time implementations, we can identify mainly two approaches: the use of low-pass filters (see, e.g., [97, 213]), or by approximating the delay as a finite number of linear oscillators at multiple frequencies of the one of interest, see, e.g., [86]. Recently, harmonic approaches have been also proposed in [34, 172]. With these approaches, however, asymptotic regulation cannot be anymore achieved. It is notably that in both the aforementioned two families of approaches (output regulation theory and repetitive control), the underlining unifying take-away message is that, from a practical point of view, practical regulation is the correct way of addressing the problem if robustness is sought. As a matter of fact, when looking for finite-dimensional asymptotic solutions one loose the robustness properties, while when looking for infinite-dimensional regulators one must then face with implementation issues which inevitably lead to some approximations (and therefore approximate regulation).

The objective of this chapter is to study the problem of robust output regulation for nonlinear systems. To this end, we first investigate the notion of robustness in the context of output regulation, by introducing a new framework which is able to precisely provide a definition of robustness and steady-state properties. Then, we investigate the robustness properties of linear internal models clarifying the notion of harmonic regulation in the context of periodic exosignals and non-periodic one. We recall also a series of feedback designs able to guarantee the stability of the overall closed-loop systems. These designs are mainly based on the forwarding approaches developed in Chapter 1. The robustness properties of nonlinear internal models are then analyzed. In particular, we focus on the design proposed in [137] and we show that such a design cannot be robust to any  $C^0$  perturbation, and if it is robust it is necessarily linear. Next, we provide a simple counter example showing that finite-dimensional linear internal models cannot provide robust asymptotic regulation. These two non-robustness results motivate for the introduction of a more general class of infinite-dimensional linear internal models which includes and generalizes the repetitive control approach. Finally, a finite-dimensional approximation of a repetitive control scheme is analyzed, establishing a direct connection between the framework of harmonic regulation and repetitive control approach.

### 3.1 The problem of robustness in output regulation

#### Notation

For basic concepts about topological spaces we refer to [75]. In particular, a *topology*  $\tau$  on a set  $S$  is a family of subsets of  $S$  satisfying: *i)*  $\emptyset, S \in \tau$ ; *ii)*  $\tau$  is closed under arbitrary unions; *iii)*  $\tau$  is closed under finite intersections. The elements of  $\tau$  are called *open sets*. A *topological space* is a pair  $(S, \tau)$  in which  $S$  is a set and  $\tau$  a topology on  $S$ . Given a topological space  $(S, \tau)$  and an element  $s \in S$ , a subset  $U \subset S$  is called a  $\tau$ -*neighborhood* of  $s$  if it contains an open set containing  $s$ . If  $A \subset S$ , a set  $U \subset S$  is called a neighborhood of  $A$  if it is a neighborhood of each point of  $A$ . When  $\tau$  is clear from the context, we simply write  $S$  in place of  $(S, \tau)$ . Given  $A \subset S$ , the collection  $\tau_A = \{U \cap A : U \in \tau\}$  is called the *subspace topology* induced by  $\tau$ , and the pair  $(A, \tau_A)$  is said to be a *topological subspace* of  $(S, \tau)$ . With  $A \subset S$ , we denote by  $\overset{\circ}{A}$  its interior, by  $\bar{A}$  its closure, and by  $\mathcal{K}(A)$  the set of all its compact subsets. A *directed set* is a pair  $(A, \preceq)$  in which  $A$  is a set and  $\preceq$  a *preorder* on  $A$ . When  $\preceq$  is clear, we omit it and we denote  $(A, \preceq)$  simply by  $A$ . A *net* on  $S$  is a function from a directed set  $A$  to  $S$ . A sequence is a net with  $(A, \preceq) = (\mathbb{N}, \leq)$ . We denote a net  $s : A \rightarrow S$  equivalently by  $\{s_\alpha\}_{\alpha \in A}$  or just by  $\{s_\alpha\}_\alpha$  or  $\{s_\alpha\}$  when  $A$  is clear. When  $S$  is given a topology  $\tau$ , then  $\{s_\alpha\}$  is said to converge to a point  $\bar{s} \in S$  if for every  $\tau$ -neighborhood  $U$  of  $\bar{s}$  there exists  $\bar{\alpha}_U$  such that  $s_\alpha \in U$  for all  $\alpha \in A$  satisfying  $\bar{\alpha}_U \preceq \alpha$ . With  $k \in \mathbb{N}$  and  $A$  and  $B$  metric spaces, we denote by  $\mathcal{C}^k(A, B)$  the set of  $k$ -times continuously differentiable functions

from  $A$  to  $B$ . In particular,  $\mathcal{C}^0(A, B)$  denotes the set of continuous functions  $A \rightarrow B$ . When  $A$  and  $B$  are clear from the context we will omit the arguments and write  $\mathcal{C}^k$ .

### 3.1.1 Systems, limit sets and steady-state properties

Consider a system of the form

$$\Sigma : \dot{\xi} = f_{\xi}(x), \quad (3.1)$$

defined on  $\mathbb{R}^{n_{\xi}}$ , with  $n_{\xi} \in \mathbb{N}$ . A solution to (3.1) is called *maximal* if it cannot be continued further, and *complete* if its domain is unbounded. Given a subset  $\Xi \subset \mathbb{R}^{n_{\xi}}$ , we denote by  $\mathcal{S}_{\Sigma}(\Xi)$  the set of all the maximal solutions to (3.1) originating in  $\Xi$ . When  $\Xi = \mathbb{R}^{n_{\xi}}$  we omit the argument and we write  $\mathcal{S}_{\Sigma}$ . By convention we set  $\emptyset = \mathcal{S}(\emptyset)$ . We define the *reachable tails of  $\Sigma$  from  $\Xi$*  as the sets

$$\mathcal{R}_{\Sigma}^t(\Xi) := \{\bar{x} \in \mathbb{R}^{n_{\xi}} : \bar{x} = x(s), x \in \mathcal{S}_{\Sigma}(\Xi), s \geq t\}$$

obtained for  $t \geq 0$ . The set  $t \mapsto \mathcal{R}_{\Sigma}^t(\Xi)$  is decreasing, in the sense that  $t_1 \geq t_2$  implies  $\mathcal{R}_{\Sigma}^{t_1}(\Xi) \subset \mathcal{R}_{\Sigma}^{t_2}(\Xi)$ . Therefore, the following quantity is well defined (although possibly empty)

$$\Omega_{\Sigma}(\Xi) := \bigcap_{t \geq 0} \overline{\mathcal{R}_{\Sigma}^t(\Xi)}.$$

The set  $\Omega_{\Sigma}(\Xi)$  is called the *limit set* of  $\Sigma$  from  $\Xi$ .

We say that system  $\Sigma$  (3.1) is *uniformly ultimately bounded* from  $\Xi$  if there exist a bounded subset  $K \subset \mathbb{R}^{n_{\xi}}$  and a  $t \geq 0$  such that  $\mathcal{R}_{\Sigma}^t(\Xi) \subset K$  and  $\mathcal{R}_{\Sigma}^t(\Xi) \neq \emptyset$ . We say that a set  $A$  *uniformly attracts  $\Sigma$  from  $\Xi$*  if, for each neighborhood  $U$  of  $A$ , there exists  $t \geq 0$  such that  $\mathcal{R}_{\Sigma}^t(\Xi) \subset U$ . We say that  $A$  is *forward invariant for  $\Sigma$*  if  $\mathcal{R}_{\Sigma}^0(A) \subset A$ . The limit set  $\Omega_{\Sigma}(\Xi)$  has the following properties [90, Proposition 6.26].

**Proposition 3.1.** *Let  $\Xi$  be compact, then  $\Omega_{\Sigma}(\Xi)$  is closed. If  $f_{\xi}$  is continuous and  $\Sigma$  is uniformly ultimately bounded from  $\Xi$ , then  $\Omega_{\Sigma}(\Xi)$  is nonempty, compact, uniformly attractive for  $\Sigma$  from  $\Xi$ , and it is the smallest (in the sense of inclusion) closed set with this latter property. If in addition  $\Omega_{\Sigma}(\Xi) \subset \Xi$ , then  $\Omega_{\Sigma}(\Xi)$  is also forward invariant.*

Under the assumptions of Proposition 3.1, every complete trajectory of  $\Sigma$  originating in  $\Xi$  converges asymptotically, and uniformly, to  $\Omega_{\Sigma}(\Xi)$ , which is compact and nonempty. In view of the uniform attractiveness of  $\Omega_{\Sigma}(\Xi)$  from  $\Xi$ , and in particular of the fact that it is the smallest closed set with such property, the trajectories of  $\Sigma$  originating inside  $\Omega_{\Sigma}(\Xi)$  have the usual interpretation as *limiting trajectories* of the solutions of  $\Sigma$  originating in  $\Xi$ . For this reason,  $\Omega_{\Sigma}(\Xi)$  is also referred to as the *steady-state locus* of  $(\Sigma, \Xi)$ , and the elements of  $\mathcal{S}_{\Sigma}(\Omega_{\Sigma}(\Xi))$  as its *steady-state trajectories*. The above discussion motivates the following definitions.

**Definition 3.1** (Steady-state trajectories). *Given a pair  $(\Sigma, \Xi)$ , in which  $\Sigma$  is a system of the form (3.1) and  $\Xi \subset \mathbb{R}^{n_{\xi}}$  a set, the elements of  $\mathcal{S}_{\Sigma}(\Omega_{\Sigma}(\Xi))$  are called the steady-state trajectories of  $(\Sigma, \Xi)$ .*

For the sake of compactness, we denote by

$$\mathcal{O}_{\Sigma}(\Xi) := \mathcal{S}_{\Sigma}(\Omega_{\Sigma}(\Xi))$$

the set of steady-state trajectories of  $(\Sigma, \Xi)$ .

**Definition 3.2** (Steady-state property). *A steady-state property  $\mathcal{P}$  on  $(\Sigma, \Xi)$  is a statement  $\mathcal{P}(\Sigma, \mathcal{O}_{\Sigma}(\Xi))$  on the set of the steady-state trajectories of  $(\Sigma, \Xi)$ . In particular, we say that the steady-state trajectories of  $(\Sigma, \Xi)$  enjoy  $\mathcal{P}$  (or, simply,  $(\Sigma, \Xi)$  enjoys  $\mathcal{P}$ ) if  $\mathcal{P}(\Sigma, \mathcal{O}_{\Sigma}(\Xi))$  holds true.*

The argument  $\Sigma$  in  $\mathcal{P}(\Sigma, \mathcal{O}_\Sigma(\Xi))$  is introduced to allow making statements about quantities that are “system dependent”. When  $\Sigma$  and  $\Xi$  are clear from the context, they are omitted, and we simply write  $\Omega$ ,  $\mathcal{S}$ , and  $\mathcal{P}(\mathcal{O})$  in place of  $\Omega_\Sigma(\Xi)$ ,  $\mathcal{S}_\Sigma(\Xi)$  and  $\mathcal{P}(\Sigma, \mathcal{O}_\Sigma(\Xi))$ . Some relevant steady-state properties are defined below.

**Example 3.1** (Set-Membership Property). *For a given set  $A \subset \mathbb{R}^{n_\xi}$ , the set-membership property is defined as  $\mathcal{P}_A := “ \forall \xi \in \mathcal{O}, \forall t \in \text{dom } \xi, \xi(t) \in A ”$ .*

**Example 3.2** (Equilibrium Property). *The equilibrium property is defined as  $\mathcal{P}_{\text{eq}} := “ \forall \xi \in \mathcal{O}, \forall t, s \in \text{dom } \xi, \xi(t) = \xi(s) ”$ . If  $\mathcal{P}_{\text{eq}}$  holds, then each steady-state trajectory is constant in time.*

Inspired by the *output regulation* literature, we are interested in linking the property  $\mathcal{P}$  to the asymptotic value of a *regulation error*  $e$  to a controlled plant. To this end, we consider now the case of a dynamical system described by

$$\Sigma_p : \begin{cases} \dot{x}_p = f_p(w, x_p, u) \\ y = h_p(w, x_p), \end{cases} \quad (3.2)$$

with state  $x_p \in \mathbb{R}^{n_p}$ , control input  $u \in \mathbb{R}^{n_u}$ , measured output  $y \in \mathbb{R}^{n_y}$ , and exogenous signals  $w \in \mathbb{R}^{n_w}$  generated by an exosystem

$$\Sigma_w : \dot{w} = s(w), \quad (3.3)$$

interconnected with a regulator of the form

$$\Sigma_c : \begin{cases} \dot{x}_c = f_c(x_c, y), \\ u = h_c(x_c, y). \end{cases} \quad (3.4)$$

Furthremore, we introduce a regulated error  $e \in \mathbb{R}^{n_e}$  defined as

$$e = h_e(w, x_p) \quad (3.5)$$

which may or may not be measured (i.e. be part of  $y$ ) and it is useful to define a performance requirement on the steady-state trajectories. In particular, we can define the following standard examples of regulation properties which are commonly used in output regulation literature.

**Example 3.3** (Regulation properties). *Let  $\Sigma$  be obtained as the interconnection  $\Sigma_p, \Sigma_w, \Sigma_c$  of a plant (3.2), (3.5) with an exosystem (3.3) and a controller (3.4) (in this case  $\xi = (w, x_p, x_c)$ ). Then*

- *the asymptotic regulation property  $\lim_{t \rightarrow \infty} e(t) = 0$  is defined as  $\mathcal{P}_0 := “ \forall \xi \in \mathcal{O}, \forall t \in \text{dom } \xi, e(t) := h_e(w(t), x_p(t)) = 0 ”$ ;*
- *the approximate regulation property  $\limsup_{t \rightarrow \infty} |e(t)| \leq \varepsilon$  is represented by the steady-state property  $\mathcal{P}_\varepsilon := “ \forall \xi \in \mathcal{O}, \forall t \in \text{dom } \xi, |h_e(w(t), x_p(t))| \leq \varepsilon ”$ .*

**Example 3.4** (Zero-Mean Property). *The following property, instead, characterizes a steady-state regulation error  $e$  with null DC component, without constraining its amplitude:*

$$\mathcal{P}_{\text{DC}} := “ \forall \xi \in \mathcal{O}, \int_{\text{dom } x} h_e(w(t), x_p(t)) dt = 0 ”.$$

Other more specific steady-state properties will be introduced in the forthcoming sections.

### 3.1.2 Characterization of perturbations

For compactness, here and in the rest of Section 3.1, we let

$$x := (w, x_p), \quad (3.6a)$$

$n_x = n_w + n_p$ ,  $f(x, u) := (s(w), f_p(w, x_p, u))$ ,  $h(x) := h_p(w, x_p)$  and we rewrite (3.2) as

$$\Sigma_x : \begin{cases} \dot{x} &= f(x, u) \\ y &= h(x). \end{cases} \quad (3.6b)$$

System (3.6) is referred to as the *extended plant*. In other words, we don't make any distinction between the plant state  $x$  and the exosystem state  $w$ . We further let  $F := (f, h)$ , and we suppose that it belongs to a given set of functions  $\mathcal{F}$ . For a given input  $u$ , the set of solutions of each system (3.6) is then completely defined by the specification of a point  $(F, X)$  in the product space  $\mathcal{F} \times \mathcal{X}$ , being  $X \in \mathcal{X}$  a set of initial conditions for (3.6), and  $\mathcal{X}$  a subset of the power set of  $\mathbb{R}^{n_x}$ . Since our aim is to study the asymptotic behavior of these solutions, Proposition 3.1 suggests to restrict the attention to the case in which  $\mathcal{F}$  is a set of continuous functions, and  $\mathcal{X}$  contains only compact subsets of  $\mathbb{R}^{n_x}$ . Thus, from now on we assume  $\mathcal{F} \subset \mathcal{C}^0$  and  $\mathcal{X} \subset \mathcal{K}(\mathbb{R}^{n_x})$ .

We equip  $\mathcal{F}$  with a topology  $\tau_{\mathcal{F}}$ , and  $\mathcal{X}$  with a topology  $\tau_{\mathcal{X}}$ , in this way turning  $(\mathcal{F}, \tau_{\mathcal{F}})$  and  $(\mathcal{X}, \tau_{\mathcal{X}})$  into topological spaces. Then, we endow the product space  $\mathcal{F} \times \mathcal{X}$  with the *product topology*  $\tau := \tau_{\mathcal{F}} \times \tau_{\mathcal{X}}$ , which turns  $(\mathcal{F} \times \mathcal{X}, \tau)$  itself into a topological space. The topology  $\tau$  on  $\mathcal{F} \times \mathcal{X}$  constitutes the basic mathematical structure that allows us to formally define the concept of *perturbation* in the space  $\mathcal{F} \times \mathcal{X}$ . The open sets of  $\tau$ , indeed, provide a formal characterization of the *qualitative* meaning of “vicinity” between two different points of  $\mathcal{F} \times \mathcal{X}$ , in the same way as norms usually do for vectors in  $\mathbb{R}^n$ . Different choices of  $\tau_{\mathcal{F}}$  and  $\tau_{\mathcal{X}}$  may be used to capture different ideas of “variation” of the function  $F$  and the initialization set  $X$  (see the examples below). We thus leave their specific choice to the user, and from now on we suppose that  $\tau_{\mathcal{F}}$ ,  $\tau_{\mathcal{X}}$ , and thus  $\tau$ , have been fixed once for all. With the topological space  $(\mathcal{F} \times \mathcal{X}, \tau)$  defined, and with  $(F, X) \in \mathcal{F} \times \mathcal{X}$ , we say that a set  $\mathcal{N} \subset \mathcal{F} \times \mathcal{X}$  is a *neighborhood* of  $(F, X)$  if it contains an open set  $U \in \tau$  containing  $(F, X)$ . We then call the elements of  $\mathcal{N}$  the  $\mathcal{N}$ -*perturbations* (or simply *perturbations*) of  $(F, X)$ . Some examples of possible choices of  $\tau$  are given below.

**Example 3.5** (Hausdorff Topology). *As  $\mathcal{X}$  contains only compact sets, a natural choice for  $\tau_{\mathcal{X}}$  is the Hausdorff topology, i.e. the topology induced by the Hausdorff distance  $d_{\text{H}}$ , which, for each two compact sets  $X, Z \in \mathcal{X}$ , is defined as*

$$d_{\text{H}}(X, Z) := \max \left\{ \sup_{x \in X} |x|_Z, \sup_{z \in Z} |z|_X \right\}.$$

*In this topology, a set  $Z$  is a perturbation of  $X$  if there exists  $\epsilon > 0$  such that  $X \subset Z + \epsilon\mathbb{B}$  and  $Z \subset X + \epsilon\mathbb{B}$ , with  $\epsilon$  that quantifies the entity of the perturbation.*

**Example 3.6** (Projection Topologies). *In many cases, a different topology on  $\mathcal{X}$  may be preferred. For instance, suppose we aim to characterize variations of the sets of initial conditions involving only the  $i$ -th component  $x_i$  of the initial state  $x \in X$ . In this case the Hausdorff topology is not suitable, as  $d_{\text{H}}$  weights uniformly variations in every directions. This can be rather achieved by letting  $\tau_{\mathcal{X}}$  be the topology generated<sup>2</sup> by the sets*

$$\mathcal{N}(X, \epsilon) := \{Z \in \mathcal{X} : |z_i - x_i| < \epsilon, \forall x \in X, \forall z \in Z\}$$

---

<sup>2</sup>That is, the smallest topology including such sets.

obtained by letting  $X$  and  $\epsilon$  range in  $\mathcal{X}$  and  $(0, \infty)$  respectively. The topology  $\tau_{\mathcal{X}}$  is not metrizable in this case, although the function  $d_1(X, Z) := \sup_{(x,z) \in X \times Z} |x_i - z_i|$  is a semimetric on  $\mathcal{X}$ . We also remark that  $\tau_{\mathcal{X}}$  coincides with the initial topology<sup>3</sup> of the projection map  $x \mapsto x_i$ .

**Example 3.7** (Weak  $\mathcal{C}^k$  Topology). Let  $\mathbf{P} \in \mathcal{K}(\mathbb{R}^{n_x} \times \mathbb{R}^{n_u})$  be an arbitrarily large compact set and, with  $k \in \mathbb{N}$ , let  $\mathcal{F} \subset \mathcal{C}^k$  and define the semimetric  $d_{(k, \mathbf{P})}$  on  $\mathcal{F}$  as

$$d_{(k, \mathbf{P})}(F, G) := \max_{i=0, \dots, k} \sup_{\mathbf{p} \in \mathbf{P}} |F^{(i)}(\mathbf{p}) - G^{(i)}(\mathbf{p})|.$$

The topology  $\tau_{\mathcal{F}}$  induced by  $d_{(k, \mathbf{P})}$  is called the weak  $\mathcal{C}^k$  topology [100]. We observe that  $d_{(k, \mathbf{P})}$  is a metric on the space formed by the restrictions on  $\mathbf{P}$  of the elements of  $\mathcal{F}$ . The adjective “weak” refers to the fact that we restricted the “sup” on the (pre-specified) compact set  $\mathbf{P}$ . By making  $\mathbf{P}$  vary with  $\epsilon$ , i.e. by considering the initial topology on  $\mathcal{F}$  induced by the family of functions  $\{d_{(k, \mathbf{P})}\}_{\mathbf{P} \in \mathcal{K}(\mathbb{R}^{n_x} \times \mathbb{R}^{n_u})}$ , we obtain a much finer topology called the strong  $\mathcal{C}^k$  (or compact-open) topology. Nevertheless, this strong version does not enjoy some useful properties (e.g. it is not (semi-)metrizable) that its weaker version does, and hence below we will only consider the latter.

**Example 3.8** (Topology of Parameters Perturbations). Let  $(P, \tau_P)$  be a topological space (called the parameter space), and let  $\mathcal{F}$  be a set of  $\mathcal{C}^0$  functions indexed by  $P$  (i.e.  $\mathcal{F} = \{F_p\}_{p \in P}$  with  $F_p \in \mathcal{C}^0$ ). Then  $\mathcal{F}$  models a family of functions that is parameterized by the parameter  $p \in P$ . Typically  $P$  is a subset of an Euclidean space endowed with the subset topology  $\tau_P$ . By construction, there is a surjective map  $\gamma : P \rightarrow \mathcal{F}$  such that each  $F \in \mathcal{F}$  is given by  $F = \gamma(p)$ . We may assume that  $\gamma$  is also injective (otherwise re-define  $P$  by identifying the points yielding the same  $F$ ), so as  $\gamma$  is invertible. We thus define the topology of parameter perturbations  $\tau_{\mathcal{F}}$  on  $\mathcal{F}$  to be the initial topology of  $\gamma^{-1}$ , i.e. the topology generated by the sets  $\gamma(U)$  for each open set  $U$  of  $\tau_P$ . In the relevant case in which  $P \subset \mathbb{R}^{n_p}$  for some  $n_p \in \mathbb{N}$ , and  $\tau_P$  is induced by any norm on  $\mathbb{R}^{n_p}$ , then  $\tau_{\mathcal{F}}$  is generated by the neighborhoods

$$\mathcal{N}(F, \epsilon) := \left\{ G \in \mathcal{F} : |p_F - p_G| < \epsilon, p_G := \gamma^{-1}(G) \right\}$$

for all  $F \in \mathcal{F}$  and  $\epsilon > 0$ , and in which  $p_F := \gamma^{-1}(F)$ .

**Example 3.9** (Linear Perturbations). Let  $\mathcal{F}$  be the set of linear maps. Once fixed a basis for  $\mathbb{R}^{n_x} \times \mathbb{R}^{n_u}$  and  $\mathbb{R}^{n_x} \times \mathbb{R}^{n_y}$ , an invertible map  $\gamma$  is defined that sends the matrix representation  $M_F \in \mathbb{R}^{(n_x w + n_y) \times (n_x w + n_u)} =: P$  of a given  $F \in \mathcal{F}$  to  $F$  itself. Then, this is a sub-case of Example 3.8, and the topology of parameter perturbations induced on  $\mathcal{F}$  indeed coincides with the one induced by any matrix norm on the space  $P$  of the matrix representations of  $\mathcal{F}$ . Hence, the concept of variation captured by the topology of parameter perturbations coincides with the usual notion of parameter perturbations of linear systems, which is the one used in the context of structurally stable linear regulation [44, 67, 83]. Moreover, in this case this topology also coincides with the weak  $\mathcal{C}^0$  topology on  $\mathcal{F}$  with respect to any compact neighborhood  $\mathbf{P}$  of the origin.

### 3.1.3 Definition of a robust regulator

With  $n_c \in \mathbb{N}$ ,  $f_c \in \mathcal{C}^0(\mathbb{R}^{n_c} \times \mathbb{R}^{n_y}, \mathbb{R}^{n_c})$ ,  $h_c \in \mathcal{C}^0(\mathbb{R}^{n_c} \times \mathbb{R}^{n_y}, \mathbb{R}^{n_u})$  and  $X_c \in \mathcal{K}(\mathbb{R}^{n_c})$ , consider a regulator of the form (3.4), for convenience rewritten hereafter

$$\Sigma_c : \begin{cases} \dot{x}_c &= f_c(x_c, y) & x_c(0) \in X_c \\ u &= h_c(x_c, y) \end{cases} \quad (3.7)$$

<sup>3</sup>We recall that, given a family  $\{f_\alpha\}_\alpha$  of functions  $f_\alpha : A \rightarrow (B_\alpha, \tau_{B_\alpha})$ , with  $(B_\alpha, \tau_{B_\alpha})$  topological spaces, the initial topology of  $f_\alpha$  on  $A$  is the coarsest topology for which each  $f_\alpha$  is continuous.

and consider the interconnection between the extended plant (3.6) and the regulator (3.7), which reads as

$$\Sigma_{\text{cl}}(F, X) : \begin{cases} \dot{x} &= f(x, h_c(x_c, h(x))), & x(0) \in X \\ \dot{x}_c &= f_c(x_c, h(x)), & x_c(0) \in X_c \end{cases} \quad (3.8)$$

in which we made explicit the dependence of  $\Sigma_{\text{cl}}$  from  $F$  and  $X$ . The achievement by regulator  $\Sigma_c$  of a given steady-state property  $\mathcal{P}$  for the closed-loop system  $\Sigma_{\text{cl}}(F, X)$  is the result of two subsequent goals:

1. *Stabilization requirement*: the existence of a non-empty steady state  $\Omega_{\Sigma_{\text{cl}}(F, X)}(X \times X_c)$  for (3.8) satisfying the properties of Proposition 3.1.
2. *Performance specification*: the fulfillment of  $\mathcal{P}$  by the closed-loop steady-state trajectories of  $\Sigma_{\text{cl}}(F, X)$ .

Clearly, Item 2 is of interest only if Item 1 is first ensured, as the achievement of property  $\mathcal{P}$  is asked to the steady-state trajectories of  $\Sigma_{\text{cl}}(F, X)$ , which exist only if Item 1 is first addressed.

Suppose that the regulator  $\Sigma_c$  has been tuned under the assumption that the extended plant's data  $(F, X)$  equal a given *nominal* value  $(F^\circ, X^\circ) \in \mathcal{F} \times \mathcal{X}$ . Then Items 1 and 2 above for the nominal case in which  $(F, X) = (F^\circ, X^\circ)$  are formally captured by the following definitions.

**Definition 3.3** (Nominal stability). *The regulator  $\Sigma_c$  is said to be nominally stabilizing at  $(F^\circ, X^\circ) \in \mathcal{F} \times \mathcal{X}$  if the system  $\Sigma_{\text{cl}}(F^\circ, X^\circ)$ , given by (3.8) for  $(F, X) = (F^\circ, X^\circ)$ , is uniformly ultimately bounded from  $X^\circ \times X_c$ .*

**Definition 3.4** (Nominal steady-state property). *The regulator  $\Sigma_c$  is said to achieve the steady-state property  $\mathcal{P}$  nominally at  $(F^\circ, X^\circ) \in \mathcal{F} \times \mathcal{X}$  (or to be  $\mathcal{P}$ -nominal) if it is nominally stabilizing at  $(F^\circ, X^\circ)$ , and  $(\Sigma_{\text{cl}}(F^\circ, X^\circ), X^\circ \times X_c)$  enjoys  $\mathcal{P}$  in the sense of Definition 3.2.*

As the functions of (3.8) are continuous, then, by Proposition 3.1, a nominally stabilizing regulator guarantees that Item 1 above is fulfilled. Therefore, Definition 3.4 is well posed. Let now  $\mathcal{F} \times \mathcal{X}$  be endowed with a topology  $\tau$ , as detailed in Section 3.1.2, and suppose that the same controller  $\Sigma_c$ , tuned on the nominal pair  $(F^\circ, X^\circ)$ , is applied to an extended plant (3.6) obtained by a possibly different pair  $(F, X)$ . Then, roughly speaking, the regulator  $\Sigma_c$  will be called “robust” if the same nominal behavior expressed by Definitions 3.3 and 3.4 is maintained if the actual  $(F, X)$  is “close-enough” (relative to  $\tau$ ) to  $(F^\circ, X^\circ)$ .

**Definition 3.5** (Robust stability). *The regulator (3.7) is said to be robustly stabilizing at  $(F^\circ, X^\circ) \in \mathcal{F} \times \mathcal{X}$  and with respect to  $\tau$  if there exists a  $\tau$ -neighborhood  $\mathcal{N}$  of  $(F^\circ, X^\circ)$  such that, for each  $(F, X) \in \mathcal{N}$ , the corresponding closed-loop system  $\Sigma_{\text{cl}}(F, X)$  given by (3.8) is uniformly ultimately bounded from  $X \times X_c$ .*

The  $\tau$ -neighborhood  $\mathcal{N}$  for which robust stability holds is called the *robust stability neighborhood* of  $(F^\circ, X^\circ)$ .

**Definition 3.6** (Robust steady-state property). *The regulator (3.7) is said to achieve the steady-state property  $\mathcal{P}$  robustly at  $(F^\circ, X^\circ) \in \mathcal{F} \times \mathcal{X}$  and with respect to  $\tau$  (or to be  $(\mathcal{P}, \tau)$ -robust) if it is robustly stabilizing at  $(F^\circ, X^\circ)$  with respect to  $\tau$  and, by letting  $\mathcal{N}$  the robust stability neighborhood of  $(F^\circ, X^\circ)$ , then the closed-loop system  $(\Sigma_{\text{cl}}(F, X), X \times X_c)$  given by (3.8) enjoys  $\mathcal{P}$  in the sense of Definition 3.2 for each  $(F, X) \in \mathcal{N}$ .*

In the next section we investigate the use of regulators possessing a linear internal model and particular choices of nominal steady-state properties.

## 3.2 Regulators with linear internal models

### 3.2.1 Internal model design

In this section we focus on a particular class of output-feedback regulators (3.7) embedding a *linear internal model*. In addition to the linear setting of [67, 83], linear internal models have been extensively used also in the nonlinear literature (see, e.g. [44, 45, 104, 107, 183], [D25, D26, D28]).

From now on we consider an extended plant (3.6) with a regulation error (3.5), and we assume the following.

**Assumption 3.1.** *The regulation error  $e$  is directly measured from  $y$ , i.e.  $y = (e, y_a)$  where  $y_a \in \mathbb{R}^{n_a}$ ,  $n_a := n_y - n_e$ , is an “auxiliary output”.*

Assumption 3.1 is not in principle necessary, although the slightly weaker concept of *readability*<sup>4</sup> of  $e$  from  $y$  is indeed necessary to achieve robust asymptotic regulation for linear systems [83, Proposition 2], [67, Condition 5 in Lemma 1]. Furthermore, we focus on “smooth variations” of the function  $F = (f, h)$  of the extended plant (3.6). More precisely, we suppose that  $\mathcal{F} \subset \mathcal{C}^1$  and, with  $\mathbf{X} \subset \mathbb{R}^{n_x}$  and  $\mathbf{U} \subset \mathbb{R}^{n_u}$  arbitrarily large compact neighborhoods, we let  $\mathbf{P} := \mathbf{X} \times \mathbf{U}$  and we endow  $\mathcal{F}$  with the subset topology  $\tau_{\mathcal{F}}$  induced by the weak  $\mathcal{C}^1$  topology  $\tau_{\mathcal{C}^1}$  defined in Example 3.7. Regarding the initialization set, instead, we let  $\mathcal{X} = \mathcal{K}(\mathbb{R}^{n_x})$ .

Regulators embedding a linear internal model are systems of the form (3.7) in which, possibly after a change of coordinates, the state  $x_c$  is partitioned as

$$x_c = (\eta_{\text{im}}, \eta_{\text{st}}) \quad (3.9a)$$

with  $\eta_{\text{im}} \in \mathbb{R}^{n_{\text{im}}}$  and  $\eta_{\text{st}} \in \mathbb{R}^{n_{\text{st}}}$ , being  $n_{\text{im}}, n_{\text{st}} \in \mathbb{N}$  such that  $n_{\text{im}} + n_{\text{st}} = n_c$ , and with the maps  $f_c$  and  $h_c$  making (3.7) read as follows

$$\Sigma_c^{\text{LIM}} : \begin{cases} \dot{\eta}_{\text{im}} &= \Phi \eta_{\text{im}} + \Gamma e \\ \dot{\eta}_{\text{st}} &= \phi_{\text{st}}(\eta_{\text{st}}, \eta_{\text{im}}, y) \\ u &= h_c(\eta_{\text{st}}, \eta_{\text{im}}, y). \end{cases} \quad x_c(0) \in X_c, \quad (3.9b)$$

in which  $\Phi$  and  $\Gamma$  are linear maps such that the subsystem  $\eta_{\text{im}}$  is controllable from  $e$ , and  $\Phi$  contains the same modes that we would like to reject from  $e$  at the steady state (as precised below). In the output regulation literature, the structure (3.9) is also said to be of the *post-processing* type [D12] or [32]. The subsystem  $\eta_{\text{im}}$  is the internal model unit, and it is responsible of generating the right feedforward control action ideally keeping  $e(t) = 0$  at the steady state. The subsystem  $\eta_{\text{st}}$ , instead, typically has the role of stabilizing the whole closed-loop system. We analyse now various contexts in which the dynamics of plant and/or stabilizing dynamics  $\eta_{\text{st}}$  are linear or nonlinear, new notions of output regulation properties and the relative robustness properties.

### 3.2.2 Asymptotic regulation

#### 3.2.2.1 Linear systems

As a first example, we consider the case of linear dynamics by reinterpreting the well known results of robust linear output regulation in [67, 83]. In particular, we consider the case in

<sup>4</sup>The regulation error  $e$  is said to be readable from the output  $y$ , if there exists a matrix  $Q \in \mathbb{R}^{n_e \times n_y}$  such that  $e = Qy$  [83].



which the nominal extended plant's function  $F^\circ$  is linear, the nominal exosystem's function  $s^\circ$  is marginally stable, known and unperturbed, and the canonical Linear Regulator is used [67]. In particular, we consider a system of the form

$$\Sigma_x^{\text{LIN}} : \begin{cases} \dot{w} = s^\circ w \\ \dot{x}_p = A_p x_p + B_p u + P_p w \\ y = C_y x_p + Q_y w \\ e = C_e x_p + Q_e w \end{cases} \quad (3.10)$$

We let  $\mathcal{F}_L \subset \mathcal{C}^1$  be the set of linear functions, and we suppose that  $F^\circ \in \mathcal{F}_L$ , and we define

$$\mathcal{F} := \{F \in \mathcal{F}_L : s = s^\circ\}. \quad (3.11)$$

In other words the only variations  $F$  of  $F^\circ$  that we consider are those for which  $F$  remains linear and  $S$  is untouched. The topology  $\tau_{\mathcal{F}}$  that we define on  $\mathcal{F}$  is the subset  $\mathcal{C}^1$  topology and it coincides with the usual topology of parametric perturbations of the matrix representation of  $F$ , see Example 3.8.

The control goal that we consider is *global* robust asymptotic regulation. Namely, we aim at finding a regulator ensuring  $\lim_{t \rightarrow \infty} e(t) = 0$  from every initial condition even when applied to an extended plant whose function  $F$  slightly differs from  $F^\circ$  (although remaining in  $\mathcal{F}$ ). In the language of this paper, we thus seek a  $\mathcal{P}_0$ -robust regulator, where

$$\mathcal{P}_0 := " \forall \xi \in \mathcal{O}, \forall t \in \text{dom } \xi, h_e(w(t), x_p(t)) = 0 " \quad (3.12)$$

with  $h_e(w, x_p = C_e x_p + Q_e w)$  obtained from the definition of the plant's dynamics (3.10). As the aimed result is global in the initial conditions, we let  $X^\circ \in \mathcal{X}$  be arbitrary, and we let  $\tau_{\mathcal{X}}$  be the trivial topology  $\tau_{\mathcal{X}} := \{\emptyset, \mathcal{X}\}$ . In fact, this implies that every robust regulator necessarily achieves the objective globally in the initial conditions, since the only  $\tau_{\mathcal{X}}$ -neighborhood of  $X^\circ$  is the whole  $\mathcal{X}$ .

It is a classical result in linear control theory, that this control objective can be guaranteed by means of a regulator of the form

$$\Sigma_c^{\text{LIN}} : \begin{cases} \dot{\eta}_{\text{im}} = \Phi \eta_{\text{im}} + \Gamma e \\ \dot{\eta}_{\text{st}} = A_{\text{st}} \eta_{\text{st}} + B_{\text{im}} \eta_{\text{im}} + B_y y \\ u = K_{\text{im}} \eta_{\text{im}} + K_{\text{st}} \eta_{\text{st}} + K_y y \end{cases} \quad (3.13)$$

constructed as follows [67]:

- a)  $X_c$  is arbitrary (e.g.  $(\eta_{\text{im}}(0), \eta_{\text{st}}(0)) = 0$ ).
- b)  $\Phi$  and  $\Gamma$  are chosen so that  $(\Phi, \Gamma)$  is controllable and the characteristic polynomial of  $\Phi$  coincides with the minimal polynomial of  $s^\circ$ .
- c) The matrices  $A_{\text{st}}, B_{\text{im}}, B_y, K_{\text{im}}, K_{\text{st}}, K_y$  are chosen to stabilize the overall closed-loop system when  $w = 0$ . This choice is always possible under standard detectability and stabilizability conditions on the plant, and provided that the following *non-resonance condition* holds [67, Lemma 14]

$$\text{rank} \begin{pmatrix} A_p - \lambda I & B_p \\ C_e & 0 \end{pmatrix} = n_p + n_e, \quad \forall \lambda \in \sigma(s^\circ) \quad (3.14)$$

for all namely for all  $\lambda$  in the spectrum of  $s^\circ$ .

The regulator constructed in this way is known as the *Linear Regulator*, and it enjoys the following robustness property.

**Theorem 3.1.** *Consider a linear plant  $\Sigma_x^{\text{LIN}}$  (3.10) interconnected with a Linear Regulator  $\Sigma_c^{\text{LIN}}$  (3.13). The Linear Regulator  $\Sigma_c^{\text{LIM}}$  is  $(\mathcal{P}_0, \tau_{\mathcal{F}} \times \tau_{\mathcal{X}})$ -robust at  $(F^\circ, X^\circ)$ , with  $\mathcal{P}_0$  defined as in (3.12).*

An intuitive argument for the formidable robustness result enunciated by Theorem 3.1 is the following: no matter how large are the variations of  $F$  with respect to  $F^\circ$ , if  $F$  remains linear, then the closed-loop system still consists of a stable linear system driven by the same exosystem. Therefore, the closed-loop steady-state trajectories keep oscillating at the same frequencies, and the linear internal model of (3.9) is still able to generate the error-zeroing control action needed in the perturbed case. This “immersion” property is at the basis of most of the existing robustness results for nonlinear systems [32, 44, 102, 104, 108] and [D25] as we will detail in the next sections.

### 3.2.2.2 Integral action

Let’s now consider the case in which the exosignals  $w$  are constant values, namely  $s^\circ = 0$  and, as in the previous case, we suppose that the exosystem remains untouched, namely  $s = s^\circ = 0$ . In this case,  $w$  is simply a vector of constant parameters that, for the analysis of this part, can be considered embedded in the description of a nominal function  $F^\circ$ . In other words, we consider a plant

$$\Sigma_p^{\text{IA}} : \begin{cases} \dot{x}_p = f_p(x, u) \\ y = \begin{pmatrix} y_a \\ e \end{pmatrix} = \begin{pmatrix} h_a(x) \\ h_e(x) \end{pmatrix} \end{cases} \quad (3.15)$$

where the nominal values of the functions  $f_p, h_p$  depend on the value of  $w$ . Our objective is to satisfy an asymptotic regulation property (3.12). Then, we allow general  $\mathcal{C}^1$  perturbations of  $F$ , thus including the case in which the perturbed function  $F$  may be *nonlinear*. In particular, we let  $\mathcal{X} = \mathcal{K}(\mathbb{R}^{n_x})$  and, as in [D25] we let  $\mathcal{F}$  be an arbitrary subset of  $\mathcal{C}^1$ . We endow  $\mathcal{X}$  with an arbitrary topology  $\tau_{\mathcal{X}}$ , and we let  $\tau_{\mathcal{F}}$  be the subset topology induced by the weak  $\mathcal{C}^1$  topology (Example 3.7) on an arbitrary compact neighborhood  $\mathbf{P} \subset \mathbb{R}^{n_x} \times \mathbb{R}^{n_u}$  of the origin.

Then, we consider a regulator (3.9) with  $\Phi = 0$  and  $\Gamma = I$ , namely of the form

$$\Sigma_c^{\text{IA}} : \begin{cases} \dot{\eta}_{\text{im}} = e \\ \dot{\eta}_{\text{st}} = \phi_{\text{st}}(\eta_{\text{st}}, \eta_{\text{im}}, y) \\ u = h_c(\eta_{\text{st}}, \eta_{\text{im}}, y). \end{cases} \quad x_c(0) \in X_c. \quad (3.16)$$

We have the following results connecting output regulation and total stability.

**Example 3.10** (Total stability). *Suppose that  $(F^\circ, X^\circ)$  is such that the closed-loop system (3.8) has an equilibrium which is locally exponentially stable with a domain of attraction  $\mathcal{D}$  including  $X^\circ \times X_c$ . Let  $\mathcal{F} = \mathcal{C}^1$ ,  $X = \mathcal{K}(\mathbb{R}^{n_p})$ , let  $\tau_{\mathcal{F}}$  be the weak  $\mathcal{C}^1$  topology (Example 3.7) on a compact set  $\mathbf{P} := \mathbf{X} \times \mathbf{U}$  with  $\mathcal{D} \subset \mathbf{X}$ , and let  $\tau_{\mathcal{X}}$  be the Hausdorff topology on  $\mathcal{X}$ . Then for small enough perturbations  $(F, X)$  of  $(F^\circ, X^\circ)$ , the system  $\Sigma_{\text{cl}}(F, X)$  still has an equilibrium, possibly different from the nominal one, which is still locally exponentially stable (see, e.g. Lemma 5 in [D25]). This is known as total stability and, in the language of this paper, it is equivalent to  $(\mathcal{P}_{\text{eq}}, \tau_{\mathcal{F}} \times \tau_{\mathcal{X}})$ -robustness where  $\mathcal{P}_{\text{eq}}$  is the equilibrium property of Example 3.2.*

**Theorem 3.2.** Consider the plant  $\Sigma_p^{IA}$  (3.15) interconnected with the integral action based regulator  $\Sigma_c^{IA}$  (3.9). The regulator  $\Sigma_c^{IA}$  is  $(\mathcal{P}_0, \tau_{\mathcal{F}} \times \tau_{\mathcal{X}})$ -robust at  $(F^\circ, X^\circ)$ , with  $\mathcal{P}_0$  defined as in (3.12).

In particular, Theorem 3.2 summarizes the basis of the well-known *integral action* [D25]: if  $\Phi = 0$  in (3.9), and if the rest of regulator ensures local exponential stability of the controlled plant when  $w = 0$ , then for small constant  $w(t)$  and small  $\mathcal{C}^0$  (locally Lipschitz) perturbations of the plant's dynamics, the closed-loop system still has a stable equilibrium, and asymptotic regulation is achieved. Nevertheless, this immersion property is hardly satisfied in a general nonlinear setting under unstructured perturbations as we shall see in the next section.

### 3.2.3 Harmonic regulation

#### 3.2.3.1 Nonlinear perturbations and (weak) periodic robustness

In this section we allow general  $\mathcal{C}^1$  perturbations of  $F$ , thus including the case in which the perturbed function  $F$  may be *nonlinear* and the perturbation affects also the exosystem map  $s$ . In particular, we let  $\mathcal{X} = \mathcal{K}(\mathbb{R}^{n_x})$  and, as in [D25, D26, D28], we let  $\mathcal{F}$  be an arbitrary subset of  $\mathcal{C}^1$ . We endow  $\mathcal{X}$  with an arbitrary topology  $\tau_{\mathcal{X}}$ , and we let  $\tau_{\mathcal{F}}$  be the subset topology induced by the weak  $\mathcal{C}^1$  topology (Example 3.7) on an arbitrary compact neighborhood  $\mathbf{P} \subset \mathbb{R}^{n_x} \times \mathbb{R}^{n_u}$  of the origin.

In this setting, a robustness result of the kind given in Theorem 3.1 is no more possible in general. Nevertheless, on the lines of [D26, D28], we can show that a regulator of the kind (3.9), embedding a suitably designed linear internal model, can still guarantee robustness of a weaker, approximate regulation objective consisting in the rejection from  $e$  of the harmonics included in the internal model dynamics. We treat here the periodic case in which the frequencies included in the internal models are multiple of a fundamental one. We postpone the more general case of arbitrary frequencies below.

As our aim is to highlight the role of the linear internal model in a nonlinear setting, we do not restrict the possible exosystem dynamics and we do not fix the other parts of the regulator (3.9) (i.e. the maps  $\phi_{st}$  and  $h_c$ ), which unlike the previous case can be nonlinear. We rather give a general robustness result (Theorem 3.3) which is independent from their specific choice, provided that some basic robust stability properties hold. This permits to separate the contributions of the exosystem and of the subsystems  $\eta_{im}$  and  $\eta_{st}$  of (3.9) in terms of their effect on the steady-state trajectories of the closed-loop system. Later in the section, we support Theorem 3.3 with two other results giving conditions on the exosystem and on  $(\phi_{st}, h_c)$  ensuring that its assumptions are fulfilled.

Now consider a regulator of the form (3.9), in which  $\Phi$  and  $\Gamma$  are chosen as follows: we first fix an arbitrary period  $T > 0$ , and an arbitrary number  $N_o \in \mathbb{N}$  of harmonics to reject. Then, we choose  $n_{im}$ ,  $\Phi$  and  $\Gamma$  in such a way that

IM-A)  $n_{im} := (2N_o + 1)n_e$ .

IM-B) By denoting with  $i$  the imaginary unit, the spectrum of  $\Phi$  is selected as

$$\sigma(\Phi) = \{0\} \cup \left( \bigcup_{k=1}^{N_o} \left\{ i \frac{2\pi k}{T}, -i \frac{2\pi k}{T} \right\} \right)$$

in which each eigenvalue has algebraic and geometric multiplicity  $n_e$ .

IM-C)  $(\Phi, \Gamma)$  is controllable.

Item IM-B, in particular, implies that the unforced (i.e. with  $e = 0$ ) internal model subsystem  $\eta_{\text{im}}$  can generate all the  $T$ -periodic signals having a non-zero bias and the first  $N_o$  harmonics starting from the fundamental frequency  $1/T$ .

We now characterize the robustness properties of any regulator (3.9) embedding the internal model defined by Items IM-A, IM-B and IM-C above, in terms of asymptotic rejection from the steady-state regulation error  $e$  of a bias and the harmonics at frequencies  $k/T$ ,  $k = 1, \dots, N_o$ . For  $(F, X) \in \mathcal{F} \times \mathcal{X}$ , we denote by  $\Sigma_{\text{cl}}(F, X)$  the closed-loop system composed by the extended plant (3.6), with initial conditions in  $X$ , and the regulator (3.9) with the internal model unit constructed above. We denote by  $\xi := (w, x_p, \eta_{\text{im}}, \eta_{\text{st}})$  the overall state. Then, for a given continuous function  $\alpha : \mathbb{R} \rightarrow \mathbb{R}^m$ ,  $m \in \mathbb{N}$ , we define the Fourier coefficients

$$c_k(\alpha) := \int_0^T \alpha(t) e^{-i2\pi kt/T} dt$$

and we let

$$\mathcal{Q}_{N_o}^m := \left\{ \alpha : \mathbb{R} \rightarrow \mathbb{R}^m \mid c_k(\alpha) = 0, k = 0, \dots, N_o \right\}$$

be the subspace of the functions  $\mathbb{R} \rightarrow \mathbb{R}^m$  that have null Fourier coefficient  $c_k(\alpha)$  for all  $k = 0, \dots, N_o$ . Then, we define the following steady-state property

$$\mathcal{P}_{T, \text{weak}} := \text{“} \forall \xi \in \mathcal{O}_{\Sigma_{\text{cl}}(F, X)}(X \times X_c), \eta_{\text{im}} \text{ is not } T\text{-periodic or } e \in \mathcal{Q}_{N_o}^{n_e} \text{”}. \quad (3.17)$$

If  $\eta_{\text{im}}$  is not  $T$ -periodic, then Property  $\mathcal{P}_{T, \text{weak}}$  is always satisfied. When, however,  $\eta_{\text{im}}$  is  $T$ -periodic,  $\mathcal{P}_{T, \text{weak}}$  asks that the steady-state regulation error  $e$  has zero mean value and zero amplitude at every frequency  $k/T$ ,  $k = 1, \dots, N_o$ . Then, with  $(F^\circ, X^\circ) \in \mathcal{F} \times \mathcal{X}$  the nominal value of the extended plant's data, the following result holds.

**Theorem 3.3.** *Consider a regulator  $\Sigma_c^{\text{LIM}}$  of the form (3.9), with  $n_{\text{im}}$ ,  $\Phi$  and  $G$  chosen according to Items IM-A, IM-B and IM-C. Suppose that  $\Sigma_c^{\text{LIM}}$  is robustly stabilizing at  $(F^\circ, X^\circ)$  with respect to  $\tau_{\mathcal{X}} \times \tau_{\mathcal{F}}$ . Then the regulator is  $(\mathcal{P}_{T, \text{weak}}, \tau_{\mathcal{X}} \times \tau_{\mathcal{F}})$ -robust at  $(F^\circ, X^\circ)$ , with  $\mathcal{P}_{T, \text{weak}}$  defined as in (3.17).*

Theorem 3.3 characterizes the effect of the internal model defined by Items IM-A, IM-B and IM-C. independently on the rest of the regulator. In particular, if the remaining degrees of freedom  $(n_{\text{st}}, \phi_{\text{st}}, h_c, X_c)$  of (3.9) can be chosen to ensure robust stabilization of the closed-loop system, and that the steady-state trajectories of  $\eta_{\text{im}}$  are  $T$ -periodic, then rejection from  $e$  of the harmonics embedded in the internal model holds robustly.

We also remark that  $T$ -periodicity of the steady-state trajectories of  $\eta_{\text{im}}$  is a condition which is also exosystem-dependent, and the ability to design  $(n_{\text{st}}, \phi_{\text{st}}, h_c, X_c)$  to guarantee robust stabilization highly depends on the particular extended plant considered. For instance, if the extended plant is linear, then  $(\phi_{\text{st}}, h_c)$  can be chosen as a simple linear stabilizer, thus reducing to a particular case of the Linear Regulator of Section 3.2.2.1. If the extended plant is nonlinear, instead, only few cases are covered in the literature. For instance, in [32, 46, 137, 210] or [D12], semiglobal solutions based on “high-gain arguments” are proposed for classes of minimum-phase normal forms, and in [D25, D26, D28, D29, D46–D48] forwarding techniques are used for a class of non-necessarily minimum-phase systems in general form and for “small  $w$ ”. Under suitable conditions, and if the solutions of the exosystem are  $T$ -periodic, some of these design solutions yield regulators of the form (3.9) which are robustly stabilizing at  $(F^\circ, X^\circ)$  and that also ensure that  $\eta_{\text{im}}$  is  $T$ -periodic at the steady state. Therefore, they strengthen the result of Theorem 3.3 to robustness with respect to the following steady-state property

$$\mathcal{P}_T := \text{“} \forall \xi \in \mathcal{O}_{\Sigma_{\text{cl}}(F, X)}(X \times X_c), e \in \mathcal{Q}_{N_o}^{n_e} \text{”} \quad (3.18)$$

which represents the “strong” version of  $\mathcal{P}_{T, \text{weak}}$ .

### 3.2.3.2 Achieving strong periodic robustness

In this section, we further investigate the problem of individuating sufficient conditions under which the claim of Theorem 3.3 may be strengthened to  $\mathcal{P}_T$ -robustness, where  $\mathcal{P}_T$  is defined in (3.18).

First, we consider a *local* (in the initial conditions) result. In this case, we let  $\mathcal{F} = \mathcal{F}_w \times \mathcal{F}_p$ , where  $\mathcal{F}_w$  is a set of  $\mathcal{C}^1$  functions  $\mathbb{R}^{n_w} \rightarrow \mathbb{R}^{n_w}$  and  $\mathcal{F}_p$  is a set of  $\mathcal{C}^2$  functions of the form  $(f_p, h_p)$ , with  $f_p : \mathbb{R}^{n_w} \times \mathbb{R}^{n_p} \times \mathbb{R}^{n_u} \rightarrow \mathbb{R}^{n_p}$  and  $h_p : \mathbb{R}^{n_w} \times \mathbb{R}^{n_p} \rightarrow \mathbb{R}^{n_y}$ . We endow  $\mathcal{F}_w$  with an arbitrary topology  $\tau_{\mathcal{F}_w}$  and, with  $\mathbf{X} \subset \mathbb{R}^{n_w} \times \mathbb{R}^{n_p}$  and  $\mathbf{U} \subset \mathbb{R}^{n_u}$  arbitrarily large compact neighborhoods of the respective origins, we endow  $\mathcal{F}_p$  with the subset topology  $\tau_{\mathcal{F}_p}$  induced by the weak  $\mathcal{C}^2$  topology on  $\mathbf{P} := \mathbf{X} \times \mathbf{U}$  (see Example 3.7). We then let  $\tau_{\mathcal{F}} := \tau_{\mathcal{F}_w} \times \tau_{\mathcal{F}_p}$ . This allows us to consider “independent variations” of  $s$  and  $(f_p, h_p)$ , and thus to better distinguish the assumptions on the exosystem from that on the controlled plant. Finally, we let  $\mathcal{X} = \mathcal{K}(\mathbb{R}^{n_x})$ , and we endow it with the Hausdorff topology  $\tau_{\mathcal{X}}$  (see Example 3.5).

We look at the closed-loop system  $\Sigma_{\text{cl}}(F, X)$ , given by interconnection between the extended plant (3.6) and the regulator (3.9), as the cascade of the exosystem

$$\dot{w} = s(w), \quad (3.19)$$

into the controlled plant

$$\Sigma_{\text{pc}} : \begin{cases} \dot{x}_p &= f_p(w, x_p, h_c(\eta_{\text{st}}, \eta_{\text{im}}, h_p(w, x_p))) \\ \dot{\eta}_{\text{im}} &= \Phi \eta_{\text{im}} + \Gamma h_e(w, x_p) \\ \dot{\eta}_{\text{st}} &= \phi_{\text{st}}(\eta_{\text{st}}, \eta_{\text{im}}, h_p(w, x_p)). \end{cases} \quad (3.20)$$

Let  $F^\circ = (s^\circ, f_p^\circ, h_p^\circ) \in \mathcal{F}$  denote the nominal extended plant function. Then, we make the following assumption.

**Assumption 3.2.** *The following hold:*

1. *There exists a  $\tau_{\mathcal{F}_w}$ -neighborhood  $\mathcal{N}_w$  of  $s^\circ$  and, for every  $\epsilon > 0$ , a  $\delta(\epsilon) > 0$ , such that every solution to (3.19) with  $s \in \mathcal{N}_w$  and satisfying  $|w(0)| \leq \delta(\epsilon)$  also satisfies  $|w(t)| \leq \epsilon$  for all  $t \geq 0$ . Moreover, the solutions to (3.19) with  $s \in \mathcal{N}_w$  satisfy*

$$\lim_{t \rightarrow \infty} |w(t+T) - w(t)| = 0$$

*uniformly*<sup>5</sup>.

2. *The triple  $(n_{\text{im}}, \Phi, \Gamma)$  is chosen according to Items IM-A, IM-B and IM-C,  $X_c$  is compact, the functions  $\phi_{\text{st}}$  and  $h_c$  are  $\mathcal{C}^2$ , and the system  $\Sigma_{\text{pc}}$  with  $w = 0$  and with  $(f_p, h_p) = (f_p^\circ, h_p^\circ)$  nominal is locally exponentially stable with a domain of attraction including  $X_p^\circ \times X_c$ .*

Item 1 of Assumption 3.2 consists of two parts. The first is a marginal stability requirement on the origin of the exosystem state-space which is *uniform* in the perturbations of the function  $s$  inside  $\mathcal{N}_w$ , in the sense that the scalar  $n_\delta(\epsilon)$  is, for fixed  $\epsilon$ , the same for all  $s \in \mathcal{N}_w$ . The second requires that the solutions of the exosystem with  $s \in \mathcal{N}_w$  are asymptotically  $T$ -periodic, uniformly over compact subsets of initial conditions. Item 2, instead, requires the *nominal* controlled plant (3.20) to be locally exponentially stable when  $w = 0$ . This, in turn, can be seen as a design requirement (see Definition 3.3) for the remaining parts  $(n_{\text{st}}, \phi_{\text{st}}, h_c, X_c)$  of the regulator, which have to be designed to locally stabilize the plant when  $w = 0$ . Under these assumptions, the following result holds.

<sup>5</sup>That is, if for every  $\epsilon > 0$  and every  $W \in \mathcal{K}(\mathbb{R}^{n_w})$ , there exists  $r > 0$  such that every solution  $w$  to (3.19) originating in  $W$  satisfies  $|w(t+T) - w(t)| \leq \epsilon$  for all  $t \geq r$ .

**Proposition 3.2.** *Suppose that Assumption 3.2 holds. Then the regulator (3.9) is  $(\mathcal{P}_T, \tau_{\mathcal{F}} \times \tau_{\mathcal{X}})$ -robust at  $(F^\circ, \{0\})$ , with  $\mathcal{P}_T$  defined in (3.18).*

The claim of Proposition 3.2, is *local* in the initial condition, meaning that the nominal initialization set for the extended plant is  $X^\circ = \{0\}$ . In fact, being  $\tau_{\mathcal{X}}$  the Hausdorff topology, any element of any  $\tau_{\mathcal{X}}$ -neighborhood of  $X^\circ$  contains an open ball around the origin (see Example 3.5). In this sense, the result of Proposition 3.2 generalizes the design philosophy of [D26,D28], in which local asymptotic stability of the controlled plant is achieved by forwarding techniques.

We consider now a non-local extension of the result of Proposition 3.2. We let  $\mathcal{F}$  be an arbitrary subset of  $\mathcal{C}^1$ , which we endow with the subset topology  $\tau_{\mathcal{F}}$  induced by the weak  $\mathcal{C}^1$  topology on the compact set  $\mathbf{P} := \mathbf{X} \times \mathbf{U}$ , with  $\mathbf{X} \subset \mathbb{R}^{n_w} \times \mathbb{R}^{n_p}$  and  $\mathbf{U} \subset \mathbb{R}^{n_u}$  arbitrarily large compact neighborhoods of the origin. Then, we let  $\mathcal{X} = \mathcal{K}(\mathbb{R}^{n_x})$ , and we endow it with an arbitrary topology  $\tau_{\mathcal{X}}$ . We let  $\tau := \tau_{\mathcal{F}} \times \tau_{\mathcal{X}}$ . With  $F^\circ \in \mathcal{F}$  the nominal extended plant's function and  $X^\circ \in \mathcal{X}$  the nominal set of initial conditions, we assume the following.

**Assumption 3.3.** *There exists  $\tau$ -neighborhood  $\mathcal{N}$  of  $(F^\circ, X^\circ)$  such that, for each  $(F, X) \in \mathcal{N}$ , the following hold:*

1. *The closed-loop system (3.19)-(3.20) is uniformly ultimately bounded from  $X \times X_c$ .*
2. *The solutions  $w$  to (3.19) originating in  $W := \{w \in \mathbb{R}^{n_w} : (w, x_p) \in X\}$  satisfy*

$$\lim_{t \rightarrow \infty} |w(t+T) - w(t)| = 0$$

*uniformly.*

3. *The controlled plant (3.20) is incrementally input-to-state stable in the sense of [17, Definition 4.1] on  $X \times X_c$ , and with respect to the input  $w$ . Namely, there exist  $\beta \in \mathcal{KL}$ , and  $\rho \in \mathcal{K}$  such that, for every two solutions  $(w, x_p, x_c)$  and  $(w', x'_p, x'_c)$  of the closed-loop system (3.19)-(3.20) originating in  $X \times X_c$  the following holds*

$$\begin{aligned} |(x_p(t), x_c(t)) - (x'_p(t), x'_c(t))| &\leq \beta(|(x_p(0), x_c(0)) - (x'_p(0), x'_c(0))|, t) \\ &\quad + \rho\left(\sup_{s \in [0, t]} |w(s) - w'(s)|\right) \end{aligned}$$

*for all  $t \geq 0$ .*

Assumption 3.3 extends to a non-local setting the basic properties implied locally by the previous Assumption 3.2. In addition to uniform ultimate boundedness of the closed-loop system, Assumption 3.3 requires the perturbed controlled plant to satisfy a non-local *incremental input-to-state stability* property with respect to the exogenous signals  $w$  [17]. We remark that the same property can be also characterized in terms of *convergent systems* [174], and we refer the reader to [17, 150, 152, 174], [D44, D46–D48] and the references therein for control design techniques ensuring that such property holds. Further details are given below in Section 3.2.4.

Under Assumption 3.3, the following result holds.

**Proposition 3.3.** *Suppose that Assumptions 3.2 and 3.3 holds. Then the regulator (3.9) is  $(\mathcal{P}_T, \tau)$ -robust at  $(F^\circ, X^\circ)$ , with  $\mathcal{P}_T$  defined as in (3.18).*

### 3.2.3.3 Robustness of Arbitrary Harmonics Regulation

The results of Sections 3.2.3 and 3.2.3.2 apply to the case in which the frequencies included in the internal model unit of (3.9) are multiple of a fundamental frequency  $1/T$ . These results may be extended to the case in which the frequencies to reject are arbitrary, in the context of generalized Fourier coefficients. In particular, in this section we provide an extension (Theorem 3.4 below) of Theorem 3.3.

With  $d \in \mathbb{N}$ , let  $\{\nu_k\}_{k=1}^d$  be the set of frequencies to be rejected from the steady-state regulation error  $e$ , and consider a regulator of the form (3.9) in which the internal model triple  $(n_{\text{im}}, \Phi, \Gamma)$  is chosen as follows:

IM-A')  $n_{\text{im}} := (2d + 1)n_e$ .

IM-B') The spectrum of  $\Phi$  is

$$\sigma(\Phi) = \{0\} \cup \left( \bigcup_{k=1}^d \{i2\pi\nu_k, -i2\pi\nu_k\} \right)$$

in which each eigenvalue has algebraic and geometric multiplicity  $n_e$ .

IM-C')  $(\Phi, \Gamma)$  is controllable.

Let, for convenience,  $\nu_0 := 0$  and, for every  $m \in \mathbb{N}$  and every function  $\alpha : \mathbb{R} \rightarrow \mathbb{R}^m$ , define the (generalized) Fourier coefficients as

$$c'_k(\alpha) := \lim_{T \rightarrow \infty} \frac{1}{T} \int_0^T \alpha(t) e^{-i2\pi\nu_k t} dt,$$

whenever they exist. A relevant case in which  $c'_k(\alpha)$  exists for all  $k$  and  $\nu_k$  is when  $\alpha$  is *almost periodic* (see, e.g., [61, Section I.3]). Then, define the sets

$$\begin{aligned} \mathcal{L}_d^{m'} &:= \left\{ \alpha : \mathbb{R} \rightarrow \mathbb{R}^m : c'_k(\alpha) \text{ exists } \forall k = 0, \dots, d \right\}, \\ \mathcal{Q}_d^{m'} &:= \left\{ \alpha \in \mathcal{L}_d^{m'} : c'_k(\alpha) = 0 \forall k = 0, \dots, d \right\}. \end{aligned}$$

Proceeding as before, we let

$$\mathcal{P}_{\nu, \text{weak}} := \text{“ } \eta \notin \mathcal{L}_d^{n_{\text{im}'}} \text{ or } e \in \mathcal{Q}_d^{n_e'} \text{ ”}. \quad (3.21)$$

As in Sections 3.2.3 and 3.2.3.2, we let  $\mathcal{F} \subset \mathcal{C}^1$ ,  $\mathcal{X} = \mathcal{K}(\mathbb{R}^{n_x})$ ,  $\tau_{\mathcal{F}}$  be the subset weak  $\mathcal{C}^1$  topology defined in Example 3.7 on an arbitrary compact subset  $\mathbf{P}$  of  $\mathbb{R}^{n_x} \times \mathbb{R}^{n_u}$ , and  $\tau_{\mathcal{X}}$  be an arbitrary topology on  $\mathcal{X}$ . Then, with  $(F^\circ, X^\circ) \in \mathcal{F} \times \mathcal{X}$  the nominal value of the extended plant's data and the following result holds.

**Theorem 3.4.** *Consider a regulator  $\Sigma_c^{\text{LIM}}$  of the form (3.9), with  $(n_{\text{im}}, \Phi, \Gamma)$  chosen according to Items IM-A', IM-B', and IM-C'. Suppose that  $\Sigma_c^{\text{LIM}}$  is robustly stabilizing at  $(F^\circ, X^\circ)$  with respect to  $\tau := \tau_{\mathcal{F}} \times \tau_{\mathcal{X}}$ . Then the regulator is  $(\mathcal{P}_{\nu, \text{weak}}, \tau)$ -robust at  $(F^\circ, X^\circ)$ .*

As in Section 3.2.3.2, stronger properties in terms of convergence can be obtained imposing stronger stability requirements according to Definition 3.3, e.g. see Assumptions 3.2 and 3.3.

### 3.2.4 Stabilizer design

In Section 3.2.1 we studied internal-model based regulators possessing a linear internal model unit  $\eta_{\text{im}}$  dynamics, taking the form (3.9), that is

$$\Sigma_c^{\text{LIM}} : \begin{cases} \dot{\eta}_{\text{im}} &= \Phi \eta_{\text{im}} + \Gamma e \\ \dot{\eta}_{\text{st}} &= \phi_{\text{st}}(\eta_{\text{st}}, \eta_{\text{im}}, y) \\ u &= h_c(\eta_{\text{st}}, \eta_{\text{im}}, y). \end{cases} \quad x_c(0) \in X_c,$$

in which the (linear)  $\eta_{\text{im}}$ -dynamics has the role of ensuring some steady-state properties (Definition 3.4) such as the (strong) harmonic regulation property  $\mathcal{P}_T$  defined in (3.18). In this section we focus on the design of the stabilizer part, namely on the design of the functions  $\phi_{\text{st}}, h_c$  ensuring desired stability properties for the overall closed-loop system (Definition 3.3). To this end, in the rest of this section, we will suppose that the full plant state  $x_p$  is available for feedback design and we will focus on static state-feedback stabilizers. With this in mind, we will therefore focus on cascade systems of the form

$$\Sigma_{p\text{im}} : \begin{cases} \dot{x}_p = f_p(w, x_p, u) \\ \dot{\eta}_{\text{im}} = \Phi \eta_{\text{im}} + \Gamma e \\ e = h_e(w, x_p) \\ y_a = x \end{cases} \quad (x_p(0), \eta_{\text{im}}(0)) \in X_p \times X_{\text{im}} \quad (3.22)$$

and we will for a stabilizing feedback of the form

$$\Sigma_{\text{st}} : u = h_c(\eta_{\text{im}}, y_a)$$

so that the closed-loop  $\Sigma_{p\text{im}}, \Sigma_{\text{st}}$  possesses some nominal stability properties, for instance satisfying the conditions of Assumption 3.2 or 3.3. In order to design the feedback  $h_c$  we will focus on the forwarding design introduced in [141]. We start by introducing the linear case.

#### 3.2.4.1 Forwarding for linear systems

Suppose that all the dynamics in  $\Sigma_{p\text{im}}, \Sigma_{\text{st}}$  are linear. In this case, we have the following system

$$\Sigma_{p\text{im}}^{\text{LIN}} : \begin{cases} \dot{x}_p = A_p x_p + B_p u + P_p w \\ \dot{\eta}_{\text{im}} = \Phi \eta_{\text{im}} + \Gamma e \\ e = C_e x_p + Q_e w \\ y_a = x \end{cases}$$

and we look for a stabilizer of the form

$$\Sigma_{\text{st}}^{\text{LIN}} : u = K_{\text{st}} x_p + K_{\text{im}} \eta_{\text{im}}.$$

It can be shown that system  $\Sigma_{p\text{im}}$  is stabilizable under the following two conditions:

- the pair  $(A_p, B_p)$  is stabilizable;
- the non-resonance condition (3.14) holds.



Evidently, if system  $\Sigma_{pim}^{LIN}$  is stabilizable then any linear technique can be employed for the design of  $\Sigma_{st}^{LIN}$ . In this section, however, we focus on the forwarding approach developed in Section 1.4.1.1 for we know that it can be extended to the nonlinear context. Furthermore, by following such approach, we can show a new result claiming the equivalence between non-resonance condition (3.14) and an alternative condition which can be checked via the solution of a Sylvester equation (which gives at the same time the design of the stabilizer). The procedure is summarized as follows.

1. Let  $K_p$  such that the matrix  $(A_p + B_p K_p)$  is Hurwitz.
2. Define  $M$  as the solution to the sylvester equation

$$M(A_p + B_p K_p) = \Phi M + \Gamma C_e \quad (3.23)$$

3. The matrices  $K_{st}, K_{im}$  are selected as follows

$$K_{st} = K_p - b B_p^\top P - B_p^\top M^\top \Lambda M, \quad K_{im} = B_p^\top M^\top \Lambda, \quad (3.24)$$

with  $b > 0$  and  $P, \Lambda$  solution to

$$P(A_p + B_p K_p) + (A_p + B_p K_p)^\top P \prec 0, \quad \Lambda \Phi + \Phi^\top \Lambda = 0.$$

4. Check if the observability condition  $(\Phi, B_p^\top M^\top)$  is verified.

Surprisingly, the last observability condition is equivalent to the non-resonance condition (3.14) as shown in the following proposition.

**Proposition 3.4.** *Suppose  $s^\circ$  is neutrally stable, and the pair  $(A_p, B_p)$  is stabilizable. Then, the following sentences are equivalent.*

- (i) *The non-resonance condition (3.14) holds.*
- (ii) *Let  $\Phi, \Gamma$  be selected so that  $(\Phi, \Gamma)$  is controllable and the characteristic polynomial of  $\Phi$  coincides with the minimal polynomial of  $s^\circ$ . let  $K_p$  be any matrix such that  $\sigma(A_p + B_p K_p) \cap \sigma(\Phi) = \emptyset$  and let  $M$  be solution of (3.23). The pair  $(\Phi, B_p^\top M^\top, \cdot)$  is observable.*

As a last remark, we highlight that a (weak) Lyapunov function is given by

$$V(x_p, \eta_{im}) = b x_p^\top P x_p + (\eta_{im} - M x_p)^\top \Lambda (\eta_{im} - M x_p).$$

### 3.2.4.2 Forwarding for harmonic regulation

First, we focus on the minimal requirements to design a stabilizer satisfying the conditions of Assumption 3.2. To this end, we focus on plants which are described by input-affine dynamics and we suppose that the full state  $x_p$  is accessible for feedback design. In other words, we look for a state-feedback stabilizer for the cascade-system composed by the plants dynamics  $x_p$  and the internal model unit  $\eta_{im}$ , that is

$$\Sigma_{pim}^{LES} : \begin{cases} \dot{x}_p = f_p(w, x_p) + g_p(w, x_p)u \\ \dot{\eta}_{im} = \Phi \eta_{im} + \Gamma e \\ e = h_e(w, x_p) \\ y_a = x \end{cases} \quad (x_p(0), \eta_{im}(0)) \in X_p \times X_{im} \quad (3.25)$$

in which the matrices  $\Phi, \Gamma$  have been designed following for instance IM-A', IM-B' and IM-C'. In order to design a stabilizer for  $\Sigma_{\text{pim}}^{\text{LES}}$ , we state the following assumptions, which ensures stabilizability of the  $x_p$ -dynamics and a local non-resonance condition (which in turns ensures stabilizability of the overall cascade systems). Note that both conditions are necessary in the context of linear systems [67].

**Assumption 3.4.** *There exists a  $C^2$  function  $\alpha_p : \mathbb{R}^{n_p} \rightarrow \mathbb{R}^{n_u}$  such that the origin of  $\dot{x}_p = f_p(0, x_p) + g_p(0, x_p)\alpha_p(x_p)$  is locally exponentially stable and asymptotically stable with a domain of attraction  $\mathcal{A}_p \supset X_p$ .*

**Assumption 3.5.** *The following non-resonance condition holds*

$$\text{rank} \begin{pmatrix} \frac{\partial f_p}{\partial x}(0, 0) - \lambda I & g_p(0, 0) \\ \frac{\partial h_e}{\partial x}(0, 0) & 0 \end{pmatrix} = n_p + n_e, \quad \forall \lambda \in \sigma(\Phi). \quad (3.26)$$

Then, we can introduce the following function

$$M(x) := \lim_{t \rightarrow \infty} \int_0^t \exp(\Phi s) \Gamma h_e(\varphi_p(x_p^*, s), 0) ds \quad (3.27)$$

in which  $\varphi_p(x_p^*, s)$  is the trajectory of  $\dot{x}_p = f_p(0, x_p) + g_p(0, x_p)\alpha_p(x_p)$  at time  $s$  with initial condition  $x_p^*$  at time  $s = 0$ . The following result holds.

**Lemma 3.1.** *Under Assumption 3.4 the function  $M : \mathcal{A}_p \rightarrow \mathbb{R}^{n_{\text{im}}}$  defined in (3.27) is  $C^2$  and solution of*

$$\frac{\partial M}{\partial x_p}(x_p) [f_p(0, x_p) + g_p(0, x_p)\alpha_p(x_p)] = \Phi M(x_p) + \Gamma h_e(x, 0). \quad (3.28)$$

As one can note from equation (3.28), the function  $M$  so defined is the equivalent nonlinear version of the solution to the Sylvester equation (3.23).

Then, recall that, in view of Assumption 3.4, a converse Lyapunov function (see, for instance, [123]) can be used to establish the existence of a  $C^1$  function  $V_p : \mathcal{A} \rightarrow \mathbb{R}$  which is positive definite and proper on  $\mathcal{A}_p$  and a positive definite function  $W_p : \mathcal{A}_p \rightarrow \mathbb{R}$  quadratic around the origin such that

$$\frac{\partial V_p}{\partial x_p}(x_p) [f_p(0, x_p) + g_p(0, x_p)\alpha_p(x_p)] \leq -W_p(x_p), \quad \forall x_p \in \mathcal{A}_p. \quad (3.29)$$

Finally, let  $\psi_{\text{LES}} : \mathbb{R}^{n_{\text{im}}} \times \mathcal{A} \rightarrow \mathbb{R}^{n_u}$  be defined as

$$\psi_{\text{LES}}(\eta_{\text{im}}, x_p) = \alpha_p(x_p) - b \left( \frac{\partial V_p(x_p)}{\partial x_p} g_p(0, x_p) \right)^\top + \left( \frac{\partial M(x_p)}{\partial x_p} g_p(0, x_p) \right)^\top \Lambda (\eta_{\text{im}} - M(x_p)) \quad (3.30)$$

where  $b, \Lambda$  are degree-of-freedom that can be used to tune the performances of the control law, with  $b > 0$  and  $\Lambda \succ 0$  being any matrix satisfying  $\Lambda \Phi + \Phi^\top \Lambda = 0$ . The feedback law  $\psi_{\text{LES}}$  extends is the nonlinear version of the linear controller (3.24) proposed for linear systems. Finally, we have the next result.

**Proposition 3.5.** *Under Assumptions 3.4, 3.5 there exists a  $C^2$  function  $h_c : \mathbb{R}^{n_{\text{im}}} \times \mathbb{R}^{n_p} \rightarrow \mathbb{R}^{n_u}$ , defined for instance by selecting  $h_c = \psi_{\text{LES}}$  as in (3.30), such that the origin of system  $\Sigma_{\text{pim}}^{\text{LES}}$  in closed-loop with  $u = h_c(\eta_{\text{im}}, y_a)$  is locally exponentially stable, when  $w = 0$ , with a domain of attraction including  $X_p \times X_{\text{im}}$ . In other words, item 2 of Assumption 3.2 is satisfied.*

We remark that a (weak) Lyapunov function is given by

$$V(x_p, \eta_{\text{im}}) = bV_p(x_p) + (\eta_{\text{im}} - Mx_p)^\top \Lambda (\eta_{\text{im}} - Mx_p).$$

It is worth observing that the design of  $\psi_{\text{LES}}$  in (3.30) relies on the exact knowledge of the function  $V_p, M$ , but alternative designs of a stabilized feedback law based on the approximation of  $V_p$  and/or  $M$  are possible, see, for instance [141] or Section III in [D25] and references therein.

### 3.2.4.3 Incremental forwarding for harmonic regulation

If stronger properties are sought, as in the context of incremental ISS properties required in Assumption 3.3, then we need to restrict ourselves to a more particular class of systems. In particular, consider the case in which the plants dynamics are input-to-state affine and the ex-signal  $w$  satisfies a matching condition, namely the cascade composed by the plant  $x_p$  and internal model unit  $\eta_{\text{im}}$  takes the form

$$\Sigma_{\text{pim}}^{\delta\text{ISS}} : \begin{cases} \dot{x}_p = f_p(x_p) + g_p(x_p)(u + \delta(w)) \\ \dot{\eta}_{\text{im}} = \Phi\eta_{\text{im}} + \Gamma e \\ e = h_e(x_p) + r(w) \\ y_a = x \end{cases} \quad (x_p(0), \eta_{\text{im}}(0)) \in \mathbb{R}^{n_p} \times \mathbb{R}^{n_{\text{im}}}, \quad (3.31)$$

for some nonlinear smooth functions  $\delta : \mathbb{R}^{n_w} \rightarrow \mathbb{R}^{n_u}$  and  $r : \mathbb{R}^{n_w} \rightarrow \mathbb{R}^{n_e}$ . In this context, following the conditions established in Chapter 1, the following assumptions are stated.

**Assumption 3.6.** *There exists a  $C^1$  matrix function  $P_p : \mathbb{R}^{n_p} \rightarrow \mathbb{R}^{n_p} \times \mathbb{R}^{n_p}$  taking positive definite symmetric values, a function  $\alpha_p : \mathbb{R}^{n_p} \rightarrow \mathbb{R}^{n_u}$  and positive real numbers  $\underline{p}, \bar{p}, \varepsilon > 0$  such that the following hold for all  $x_p \in \mathbb{R}^{n_p}$*

$$\begin{aligned} 0 &\preceq \bar{p}I \preceq P_p(x_p) \preceq \underline{p}I, \\ L_{f_0}P_p(x_p) &\preceq -\varepsilon P(x_p), \\ L_gP_p(x_p) &= 0 \end{aligned}$$

with  $f_0(x_p) = f_p(x_p) + g_p(x_p)\alpha_p(x_p)$ .

Note that a possible manner to satisfy the previous conditions is to look for a solution to the following PDEs:

$$\begin{aligned} L_fP_p(x_p) - P_p(x_p)g_p(x_p)g_p^\top(x_p)P_p(x_p) &\preceq -\varepsilon P(x_p), \\ \frac{\partial \alpha_p}{\partial x_p}^\top(x_p) &= P_p(x_p)g_p(x_p), \end{aligned}$$

which provides a pre-contractive feedback law  $u = \alpha(x_p)$  with the infinite-gain margin property, as shown in Section 1.3.1.2, Lemma 1.3.

As a consequence of Assumption 3.6, the system

$$\dot{x}_p = f_p(x_p) + g_p(x_p)\alpha_p(x_p) + g_p(x_p)\delta \quad (3.32)$$

is  $\delta$ ISS with respect to any signal  $\delta$  taking bounded values. When  $d = 0$ , the origin is globally exponentially stable. Let consider now the function  $M$  defined in (3.27). In view of the properties of system (3.32),  $M$  is defined for all  $x_p \in \mathbb{R}^{n_p}$ . In order to propagate the  $\delta$ ISS properties to the cascade system  $\Sigma_{\text{pim}}^{\delta\text{ISS}}$  the following assumption is then stated.

**Assumption 3.7.** *There exist a real number  $L_M$  and a matrix  $\Upsilon$  such that the function  $M : \mathbb{R}^{n_p} \rightarrow \mathbb{R}^{n_{im}}$  defined in (3.27) as the solution to (3.28) satisfies*

$$\left| \frac{\partial M}{\partial x_p}(x_p) \right| \leq L_M, \quad \frac{\partial M}{\partial x_p}(x_p)g(x_p) = \Upsilon, \quad \forall x_p \in \mathbb{R}^{n_p}.$$

The first condition of Assumption 3.7 asks for a globally Lipschitz condition. Then second one instead replaces Assumption 3.5. In practice, the local controllability ensured at the origin by the non-resonance condition (3.26) is transformed into a uniform global controllability condition. This can be seen by performing the change of coordinates

$$\eta_{im} \mapsto \xi_{im} := \eta_{im} - M(x_p)$$

which transform the the  $(x_p, \eta_{im})$ -dynamics into a system of the form

$$\begin{aligned} \dot{x}_p &= f_p(x_p) + g_p(x_p)\alpha_p(x_p) + g_p(x_p)[v + \delta(w)] \\ \dot{\xi}_{im} &= \Phi\xi_{im} - \Upsilon(v + \delta(w)) + \Gamma r(w). \end{aligned}$$

if we set  $u = \alpha_p(x_p) + v$  and we use equation (3.28). It is immediately seen that the  $(x_p, \xi_{im})$ -dynamics are now decoupled, the  $x_p$ -dynamics is  $\delta$ ISS with respect to the new control input  $v$  and the disturbance  $\delta(w)$ , and the  $\xi_{im}$ -dynamics is linear. The adjective uniform refers therefore to the fact that the quantity  $\frac{\partial M}{\partial x_p}(x_p)g(x_p)$  is constantly equal to  $\Upsilon$  and therefore, for the  $\xi_{im}$ -dynamics, we can look for an Euclidean metric in order to design a contractive stabilizer.

Finally, we introduce the following function  $\psi_{\delta ISS} : \mathbb{R}^{n_{im}} \times \mathbb{R}^{n_p} \rightarrow \mathbb{R}^{n_u}$  defined as

$$\psi_{\delta ISS}(\eta_{im}, x_p) := \alpha_p(x_p) + \Upsilon^\top \Lambda (\eta_{im} - M(x_p)) \quad (3.33)$$

where  $\Lambda \succ 0$  is any matrix satisfying  $\Lambda\Phi + \Phi^\top\Lambda = 0$ . We can state the following result. Such a controller is the (nonlinear) incremental version of the previous feedback laws (3.24) and (3.30).

**Proposition 3.6.** *Under Assumptions 3.6 and 3.7 there exists a  $C^2$  function  $h_c : \mathbb{R}^{n_{im}} \times \mathbb{R}^{n_p} \rightarrow \mathbb{R}^{n_u}$ , defined for instance by selecting  $h_c = \psi_{\delta ISS}$  as in (3.33), such that the origin of system  $\Sigma_{pim}^{\delta ISS}$  in closed-loop with  $u = h_c(\eta_{im}, y_a)$  is incrementally input-to-state stable with respect to any bounded signal  $w$ . In other words, item 2 of Assumption 3.3 is satisfied.*

Evidently, the conditions imposed by Assumption 3.7 by the previous proposition may be particularly stringent. Some milder conditions can be obtained following the approximated approach proposed in Theorem 1.4 where the function  $M$  is replaced by a suitable approximation  $\bar{M}$  satisfying the conditions of Assumption 3.7, and by asking the preliminary feedback  $\alpha_p$  to satisfy a robustness requirement as in Assumption 1.5.

#### 3.2.4.4 Incremental forwarding for Lipschitz systems

Finally, as a last part of this section, we propose a possible approach to apply the results of Theorem 1.5 introduced in Section 1.4.2 in the considered harmonic regulation context. In particular, consider the case in which the plant's dynamics takes the form

$$\begin{aligned} f_p(w, x, u) &= A_p x_p + N_p \varphi_p(H_p x_p) + B_p u + \delta(w), \\ h_e(w, x_p) &= C_e x_p + D_e \varphi_p(H_p x_p) + r(w), \end{aligned} \quad (3.34)$$

where  $\varphi_p(s)$  is a scalar  $C^1$  nonlinearity with  $\varphi_p(0) = 0$ , and  $\delta : \mathbb{R}^{n_w} \rightarrow \mathbb{R}^{n_p}$  and  $r : \mathbb{R}^{n_w} \rightarrow \mathbb{R}^{n+e}$  are smooth functions. The cascade  $(x_p, \eta_{\text{im}})$  reads

$$\Sigma_{\text{pim}}^{\text{LIP}} : \begin{cases} \dot{x}_p = A_p x_p + N_p \varphi_p(H_p x_p) + B_p u + \delta(w) \\ \dot{\eta}_{\text{im}} = \Phi \eta_{\text{im}} + \Gamma e \\ e = C_e x_p + D_e \varphi_p(H_p x_p) + r(w) \\ y_a = x \end{cases} \quad (x_p(0), \eta_{\text{im}}(0)) \in \mathbb{R}^{n_p} \times \mathbb{R}^{n_{\text{im}}}. \quad (3.35)$$

For such a class of systems, we first assume that Assumption 3.6 is satisfied with respect to some constant metric  $P = P^\top \succ 0$ , namely we suppose to look for a feedback law of the form  $u = K_p x_p$  satisfying

$$P \left( A_p + B_p K_p + N_p \frac{\partial \varphi_p}{\partial x_p}(H_p x_p) H_p \right) + \left( A_p + B_p K_p + N_p \frac{\partial \varphi_p}{\partial x_p}(H_p x_p) H_p \right)^\top P \preceq -\varepsilon P \quad (3.36)$$

Then, let  $\mathcal{Q}$  be defined as the following matrix parametrized by  $\mu$  and  $\omega$

$$\mathcal{Q}(\mu, \omega) := \begin{pmatrix} (A_p + B_p K_p)^\top \otimes I - I \otimes \Phi(\omega) & -C_e^\top \otimes I \\ H_p^\top (\mu B_p^\top - N_p^\top) \otimes I & -H_p^\top D_e^\top \otimes I \end{pmatrix} \quad (3.37)$$

where  $\Phi$  has been previously chosen to satisfy the requirements IM-A' and IM-B' and in which we explicitly expressed the dependency on the parameter  $\omega = (\omega_1, \dots, \omega_d)$  for some  $d \geq 1$ . Now, let  $\mathcal{M} \subset \mathbb{R}$  be the set parametrized by some  $\lambda \in \mathbb{R}$  defined as

$$\mathcal{M}(\lambda) := \left\{ \mu \in \mathbb{R} : P \left( A_p + B_p K_p + (N_p + \mu B_p) \frac{\partial \varphi}{\partial x_p}(H_p x_p) H_p \right) + \left( A_p + B_p K_p + (N_p + \mu B_p) \frac{\partial \varphi}{\partial x_p}(H_p x_p) H_p \right)^\top P \preceq -\lambda I, \quad \forall x \in \mathbb{R}^n \right\}.$$

Then the following holds.

**Proposition 3.7.** *Consider system (3.34) and assume that inequality (3.36) holds for some matrices  $P = P^\top \succ 0$ ,  $K_p$ , and for a real number  $\varepsilon > 0$ . Let  $\Phi, d$  be chosen according to IM-A' and IM-B' as in Section 3.2.3.3. Given  $\omega = (\omega_1, \dots, \omega_d)$  with  $\omega_k = 2\pi\nu_k$  for any  $k = 0, 1, \dots, d$ , let  $\lambda > 0$  and suppose there exists  $\bar{\mu} \in \mathcal{M}(\lambda)$  such that  $\det(\mathcal{Q}(\bar{\mu}, \omega)) = 0$ . Let  $M, \Gamma$  be any solution to*

$$\mathcal{Q}(\bar{\mu}, \omega) \begin{pmatrix} \text{vec}(M) \\ \text{vec}(\Gamma) \end{pmatrix} = 0.$$

If  $(\Phi, B_p^\top M^\top)$  is detectable and  $(\Phi, \Gamma)$  is controllable, then system  $\Sigma_{\text{pim}}^{\text{LIP}}$  in closed-loop with

$$u = K_p x_p + \kappa B_p^\top M^\top \Lambda (\eta_{\text{im}} - Mx) + \bar{\mu} \varphi_p(H_p x_p)$$

with  $\kappa > 0$  and  $\Lambda \succ 0$  any matrix satisfying  $\Lambda \Phi + \Phi^\top \Lambda = 0$ , is  $\delta$ ISS with respect to any bounded signal  $w$ . In other words, item 2 of Assumption 3.3 is satisfied.

### 3.3 Nonlinear internal models

#### 3.3.1 Asymptotic regulation via nonlinear internal models

In the previous sections we have shown that, for a class of nonlinear problems, a regulator embedding a linear internal model is able to guarantee robust harmonic rejection from the steady-state regulation error. Nevertheless, results concerning asymptotic regulation have been only given in the linear case when  $s$  is not uncertain. In this section, we consider regulators of a general form (3.7), in which also the internal model is allowed to be nonlinear. The only constraints we consider are the finite-dimensionality of the state space and smoothness of the vector fields  $f_c$  and  $h_c$ . This, indeed, guarantees the existence of the limit set as detailed in Proposition 3.1.

In the context of minimum-phase single-input-single-output normal forms with unitary relative degree<sup>6</sup>, we show that, while it is true that a nonlinear regulator always exists ensuring nominal asymptotic regulation, robust asymptotic regulation is instead *impossible* in the relevant case of  $\mathcal{C}^0$  ((locally Lipschitz)) perturbations. Then, we show that there exist (very simple) systems for which there can not exist a smooth finite-dimensional regulator ensuring robust asymptotic regulation. For simplicity, and since it represents the most general available existence result, we shall restrict the discussion to the design of [137] (recalled hereafter) in the context of single-input-single-output minimum-phase normal forms. We remark, however, that the same conclusions apply to the regulator in [46], [162], and [55], as well as to all their numerous extensions.

We consider systems of the form (3.2) with  $n_y = n_e = 1$ ,  $y = e$ , with the plant's state  $x_p$  which admits the decomposition  $x_p := (\zeta, e)$ ,  $\zeta \in \mathbb{R}^{n_\zeta}$ ,  $n_\zeta = n_p - 1$ , with  $(f_p, h_p)$  such that, in certain coordinates, the plant's equations together with the exosystem  $\Sigma_w$  in (3.3) read<sup>7</sup> as follows

$$\Sigma_x^{\text{NLIM}} : \begin{cases} \dot{w} = s(w) \\ \dot{\zeta} = \varphi(w, \zeta, e) \\ \dot{e} = q(w, \zeta, e) + u \end{cases} \quad (3.38)$$

with  $s, \varphi, q_e$  satisfying the following assumption. We refer for instance to [46, 137, 162, 182], [D19, D29, D36] and references therein for examples of control problems that can be recast in such a form.

**Assumption 3.8.** *The functions  $(s, \varphi, q)$  are  $\mathcal{C}^2$  and there exists a compact set  $\mathcal{A} \subset \mathbb{R}^{n_w} \times \mathbb{R}^{n_\zeta}$  which is locally asymptotically stable for the zero-dynamics*

$$\dot{w} = s(w), \quad \dot{\zeta} = \varphi(w, \zeta, 0)$$

with an open domain of attraction  $\mathcal{D} \supset \mathcal{A}$ .

We let  $\mathcal{F}$  be the set of smooth functions  $F = (s, f_p, h_p)$  with the above properties and satisfying Assumption 3.8. Moreover, we let  $F^\circ \in \mathcal{F}$ , and  $X^\circ$  be any compact set such that, for some arbitrary bounded set  $E \subset \mathbb{R}$ ,  $X^\circ \subset \mathcal{D} \times E$ . Then, with  $\mathcal{P}_0$  the asymptotic regulation property defined in (3.12), namely

$$\mathcal{P}_0 := \text{“ } \forall \xi \in \mathcal{O}, \forall t \in \text{dom } \xi, h_e(w(t), x_p(t)) = 0 \text{”}.$$

<sup>6</sup>This is done without loss of generality, since it represents the setting in which the most general results exist.

<sup>7</sup>For simplicity we restrict to the case in which the input is linear in the  $e$ -dynamics, but the results could be also generalized to the case of  $\dot{e} = q(w, \zeta, e) + b(w, \zeta, e)u$  with the condition  $b(w, \zeta, e) \geq \underline{b}$  for all  $(w, \zeta, e) \in \mathbb{R}^{n_w} \times \mathbb{R}^{n_\zeta} \times \mathbb{R}$ .

the result of [137] can be stated, in our setting, as follows.

**Theorem 3.5.** *There always exists a finite-dimensional regulator of the form (3.7) with  $(f_c, h_c) \in \mathcal{C}^0$  which achieves the steady-state property  $\mathcal{P}_0$  nominally at  $(F^\circ, X^\circ)$ .*

Theorem 3.5 gives an affirmative answer to the question whether or not we can always find a regulator embedding a nonlinear internal model that can effectively ensure asymptotic regulation in the nominal case. In general, possibly under additional assumptions, the design of [137], as well as those of [46], [162], [55] and the related extensions, can also guarantee semi-global or global approximate regulation property robustly (i.e. the steady-state property  $\mathcal{P}_\varepsilon$  defined in Example 3.3), when the functions perturbations are meant in the  $\mathcal{C}^0$  topology.

In the next section, we study the robustness properties of the regulator which is given by Theorem 3.5. Surprisingly we will show that if such a regulator is robust in the weak  $\mathcal{C}^1$  topology defined in Example 3.7 then it is necessarily linear.

### 3.3.2 $\mathcal{C}^0$ -robust regulators are linear

In order to study the robustness properties of nonlinear regulators, we focus in this section on the design proposed in [137], which is, to certain extents, the more general. Similar reasoning and results can be however obtained also with the designs proposed in [46], [162], [55].

As show in [137], a regulator which solves the asymptotic regulation problem in the sense of Theorem 3.5 can be taken in the form

$$\Sigma_c^{\text{NLIM}} : \begin{cases} \dot{\eta}_{\text{im}} = F\eta_{\text{im}} + Gu, & \eta_{\text{im}}(0) \in H_0 \\ u = \gamma(\eta_{\text{im}}) + \kappa(e) \end{cases} \quad (3.39)$$

with  $\eta_{\text{im}} \in \mathbb{R}^{n_{\text{im}}}$ ,  $n_{\text{im}} \in \mathbb{N}$ ,  $H_0 \subset \mathbb{R}^{n_{\text{im}}}$  compact,  $(F, G) \in \mathbb{R}^{n_{\text{im}} \times n_{\text{im}}} \times \mathbb{R}^{n_{\text{im}}}$ ,  $\gamma \in \mathcal{C}(\mathbb{R}^{n_{\text{im}}}, \mathbb{R})$  and  $\kappa \in \mathcal{C}(\mathbb{R}, \mathbb{R})$ . For the forthcoming result, we don't need to keep separated the effects of  $\zeta$  and  $w$ . As a consequence, using the compact notation

$$z = (w, \zeta) \in \mathbb{R}^{n_z}, \quad n_z = n_w + n_\zeta, \quad f(z, e) = (s(w), \varphi(w, \zeta, e)), \quad q(z, e) = q(w, \zeta, e),$$

the closed-loop system  $\Sigma_p^{\text{NLIM}}\text{-}\Sigma_c^{\text{NLIM}}$  reads

$$\Sigma_{xc}^{\text{NLIM}} : \begin{cases} \dot{z} = f(z, e), & z(0) \in Z_0, \\ \dot{\eta}_{\text{im}} = F\eta_{\text{im}} + G(\gamma(\eta_{\text{im}}) + \kappa(e)), & \eta_{\text{im}}(0) \in H_0, \\ \dot{e} = q(z, e) + \gamma(\eta_{\text{im}}) + \kappa(e), & e(0) \in E_0. \end{cases} \quad (3.40)$$

We let  $\mathcal{F} \subset \mathcal{C}(\mathbb{R}^{n_x} \times \mathbb{R}, \mathbb{R}^{n_x}) \times \mathcal{C}(\mathbb{R}^{n_x} \times \mathbb{R}, \mathbb{R})$  be the set of all pairs  $(f, q)$  of locally Lipschitz continuous functions  $f$  and  $q$  such that  $f$  satisfies Assumption 3.8. Then, the following theorem summarizes the results of [137].

**Theorem 3.6.** *Consider the system (3.40) under Assumption 3.8. There exists  $n_{\text{im}} \in \mathbb{N}$  and, for every  $(f, q) \in \mathcal{F}$ , and every compact subsets  $Z_0 \subset \mathcal{D}$ ,  $E_0 \subset \mathbb{R}$  and  $H_0 \subset \mathbb{R}^{n_{\text{im}}}$ , there exist a controllable pair  $(F, G) \in \mathbb{R}^{n_{\text{im}} \times n_{\text{im}}} \times \mathbb{R}^{n_{\text{im}} \times 1}$  with  $F$  Hurwitz,  $\gamma \in \mathcal{C}(\mathbb{R}^{n_{\text{im}}}, \mathbb{R})$ ,  $\kappa \in \mathcal{C}(\mathbb{R}, \mathbb{R})$  with  $\kappa(0) = 0$ , and  $\tau \in \mathcal{C}(\mathbb{R}^{n_w}, \mathbb{R}^{n_\eta})$ , such that:*

1. For all  $z \in \mathcal{A}$

$$\frac{\partial \tau}{\partial z} f(z, 0) = F\tau(z) - Gq(z, 0). \quad (3.41)$$

2.  $\gamma(\tau(z)) = -q(z, 0)$ , for all  $z \in \mathcal{A}$ .

3. The trajectories of the closed-loop system (3.40) are complete and equibounded.
4. The set  $\mathcal{B} \times \{0\}$ , where  $\mathcal{B} := \text{graph}(\tau|_{\mathcal{A}}) = \{(z, \eta_{\text{im}}) \in \mathcal{A} \times \mathbb{R}^{n_{\text{im}}} : \eta_{\text{im}} = \tau(z)\}$ , is forward invariant and attractive from  $Z_0 \times H_0 \times E_0$  for the closed-loop system (3.40).

We now fix, once for all:

1. A nominal value  $(f^\circ, q^\circ) \in \mathcal{F}$  for the plant's functions  $(f, q)$  in  $\Sigma_{xc}^{\text{NLM}}$ .
2. The compact sets  $Z_0$  and  $E_0$  of the initial conditions, in such a way that  $0 \in E_0$  and  $\mathcal{A}^\circ \subseteq Z_0 \subset \mathcal{D}^\circ$  where  $\mathcal{A}^\circ$  is a compact set such that Assumption 3.8 holds when  $f = f^\circ$ , and  $\mathcal{D}^\circ$  is its domain of attraction.

Then, we choose  $n_{\text{im}} \in \mathbb{N}$ ,  $H_0 \subset \mathbb{R}^{n_{\text{im}}}$  compact,  $(F, G) \in \mathbb{R}^{n_{\text{im}} \times n_{\text{im}}} \times \mathbb{R}^{n_{\text{im}} \times 1}$  with  $F$  Hurwitz,  $\gamma \in \mathcal{C}(\mathbb{R}^{n_{\text{im}}}, \mathbb{R})$ , and  $\kappa \in \mathcal{C}(\mathbb{R}, \mathbb{R})$  satisfying  $\kappa(0) = 0$ , in such a way that the claim of Theorem 3.6 holds for the selected nominal data. Then, consider the system

$$\Sigma_z^\circ : \dot{z} = f^\circ(z, 0), \quad z(0) \in Z_0 \quad (3.42)$$

and let  $\mathcal{O}^\circ := \mathcal{O}_{\Sigma_z^\circ}(Z_0)$  denote the set of steady-state trajectories of system  $\Sigma_z^\circ$ , defined according to Section 3.1.1. Then, let  $\tau^\circ \in \mathcal{C}(\mathbb{R}^{n_z}, \mathbb{R}^{n_\eta})$  denote a function for which the claim of Theorem 3.6 holds for the nominal data  $(f^\circ, q^\circ)$  fixed previously and consider  $\tau^\circ(\mathcal{O}^\circ)$ , defining the ideal error-zeroing steady-state locus of the variable  $\eta_{\text{im}}$  of the nominal controller (3.39). We make the following technical assumptions on  $\gamma$  and  $\tau^\circ(\mathcal{O}^\circ)$ .

**Assumption 3.9.**  $\gamma$  is differentiable at 0, and  $\tau^\circ(\mathcal{O}^\circ)$  is star-shaped<sup>8</sup>.

Then, we have the following result concerning the robustness properties of the regulator (3.39) in terms of  $\mathcal{C}^0$  topology defined as in Example 3.7 and  $\mathcal{P}_0$  properties as defined in (3.12).

**Theorem 3.7.** Suppose that Assumption 3.9 holds. If the regulator (3.39) is  $(\mathcal{P}_0, \tau_{\mathcal{X}} \times \tau_{\mathcal{F}})$ -robust at  $(f^\circ, q^\circ)$  from  $Z_0 \times H_0 \times E_0$ , then  $\gamma$  is linear on  $\tau^\circ(\mathcal{O}^\circ)$ .

Theorem 3.7 implies that, if the regulator (3.39) is robust with respect to unstructured  $\mathcal{C}^0$  perturbations according to Example 3.7, then the restriction of its dynamics to the nominal limit set is that of a linear system. Indeed, in the nominal closed-loop limit set,  $e = 0$ , so that  $\gamma(\eta)$  is the only nonlinear term in (3.39), and Theorem 3.7 states that it is actually linear on  $\tau^\circ(\mathcal{O}^\circ)$ . We remark that the proof of this fact is based on the following technical lemma.

**Lemma 3.2.** Let  $n \in \mathbb{N}_{\geq 1}$  and  $\phi \in \mathcal{C}(\mathbb{R}^n, \mathbb{R})$ . Suppose that  $\phi$  is differentiable at 0, and that there exist  $\mu \in (0, 1)$  and a star-shaped subset  $S \subset \mathbb{R}^n$  such that

$$\phi(\mu s) = \mu \phi(s), \quad \forall s \in S.$$

Then,  $\phi$  is linear on  $S$ .

Indeed, based on the previous lemma, it suffices to consider perturbations of the form  $q(z, e) = (1 + \varepsilon)q^\circ(z, e)$  for some small  $\varepsilon$  to show that by linearity then  $\gamma$  needs to be linear. This, in turn, implies that the ideal steady-state control actions needed to keep the regulation error to zero, formally given by the outputs  $u^*$  of the system

$$\begin{aligned} \dot{z} &= f^\circ(z, 0), & z(0) &\in \mathcal{O}^\circ \\ u^* &= -q^\circ(z, 0), \end{aligned}$$

<sup>8</sup>A set  $S \subset \mathbb{R}^n$ ,  $n \in \mathbb{N}$ , is called *star-shaped* if  $x \in S \implies \lambda x \in S$  for all  $\lambda \in [0, 1]$ .



are actually all reproducible by the linear system

$$\begin{aligned}\dot{\eta} &= (F + G\Gamma)\eta, & \eta(0) &\in \tau^\circ(\mathcal{O}^\circ) \\ u &= \Gamma\eta\end{aligned}\tag{3.43}$$

where  $\Gamma$  is the Jacobian matrix of  $\gamma$  at the origin. Since (3.43) is linear and finite-dimensional, Theorem 3.7 extends the linear *internal model principle* of [83] to nonlinear systems and unstructured perturbations. Namely, a robust regulator (in the sense of weak  $\mathcal{C}^0$  topology of Example 3.7) embeds a linear internal model.

In the the next section, however, we show that a linear finite-dimensional regulator of the form (3.43) can never be robust in the  $\mathcal{C}^0$  topology.

### 3.3.3 Non-asymptotic properties of finite-dimensional linear regulators

The question of whether or not robust asymptotic regulation might be ensured by a finite-dimensional regulation has, however, a negative answer in general when perturbations are meant in the  $\mathcal{C}^0$  topology. In particular, we let  $\mathcal{R}$  be the class of problems obtained with:

1. An extended plant of the form (3.2), (3.5), for some  $n_w, n_p, n_y, n_u, n_e \in \mathbb{N}$ , satisfying Assumption 3.1.
2.  $F := (s, f_p, h_p) \in \mathcal{F} := \mathcal{C}^0$ , where  $\mathcal{F}$  is given the weak  $\mathcal{C}^0$  topology on the compact set  $\mathcal{P} := \mathbf{X} \times \mathbf{U}$ , where  $\mathbf{X} \subset \mathbb{R}^{n_x}$  and  $\mathbf{U} \subset \mathbb{R}^{n_u}$  are arbitrary compact neighborhoods of the respective origin (see Example 3.7).
3.  $X \in \mathcal{X} := \mathcal{K}(\mathbb{R}^{n_x})$  ( $n_x := n_w + n_p$ ), where  $\mathcal{X}$  is given an arbitrary topology  $\tau_{\mathcal{X}}$ .

Then, the following result holds.

**Theorem 3.8.** *There exist problems in  $\mathcal{R}$  and nominal data  $(F^\circ, X^\circ) \in \mathcal{F} \times \mathcal{X}$  for which no finite-dimensional regulator of the form (3.7) with  $(f_c, h_c) \in \mathcal{C}^1$  exists that achieves the steady-state property  $\mathcal{P}_0$  robustly at  $(F^\circ, X^\circ)$  with respect to  $\tau_{\mathcal{F}} \times \tau_{\mathcal{X}}$ .*

Theorem 3.8 can be established by a simple by counterexample. In particular, we consider a problem in  $\mathcal{R}$  obtained with  $n_w = 2$ ,  $n_p = 1$ ,  $n_y = n_e = n_u = 1$ ,  $X^\circ = W^\circ \times X_p^\circ$ , with  $W^\circ := \{(0, 1)\}$  and  $X_p^\circ \in \mathcal{K}(\mathbb{R})$  any, and with the extended plant satisfying the following equations.

$$\begin{aligned}\dot{w} &= \begin{pmatrix} 0 & 1 \\ -1 & 0 \end{pmatrix} w & w(0) &= (0, 1) \\ \dot{x}_p &= w_1 + u, & x_p(0) &\in X_p^\circ \\ e &= x_p.\end{aligned}\tag{3.44}$$

With  $N \in \mathbb{N}$ , let

$$\mathcal{T}_N = \left\{ \psi : \mathbb{R} \rightarrow \mathbb{R} : \psi(t) = \alpha + \sum_{n=1}^N (\beta^n \sin(nt) + \gamma^n \cos(nt)), \quad \alpha, \beta^n, \gamma^n \in \mathbb{R} \right\}.$$

be the vector space of all the time signals obtained as the linear composition of  $N$  harmonics and a bias. Then, the mapping  $\phi_N : \mathcal{T}_N \rightarrow \mathbb{R}^{2N+1}$  defined as

$$\psi \mapsto \phi_N(\psi) := (\alpha, \beta^1, \gamma^1, \dots, \beta^N, \gamma^N)$$

is an isomorphism. With  $\epsilon\mathbb{B}(\mathbb{R}^{2N+1})$  the ball of radius  $\epsilon > 0$  in  $\mathbb{R}^{2N+1}$ , we define the ball of radius  $\epsilon$  in  $\mathcal{T}_N$  as

$$\epsilon\mathbb{B}(\mathcal{T}_N) := \phi_N^{-1}(\epsilon\mathbb{B}(\mathbb{R}^{2N+1})) = \{\psi \in \mathcal{T}_N : |\phi_N(\psi)| < \epsilon\}.$$

Then, the following two results hold.

**Proposition 3.8.** *Suppose that, for some  $N \in \mathbb{N}$  and  $\epsilon > 0$ , there exist  $m \in \mathbb{N}$ ,  $g \in \mathcal{C}^1(\mathbb{R}^m, \mathbb{R}^m)$ ,  $\theta : \mathcal{C}^1(\mathbb{R}^m, \mathbb{R})$ , and a system of the form*

$$\dot{\xi} = g(\xi), \quad v = \theta(\xi), \quad \xi \in \mathbb{R}^m \quad (3.45)$$

such that for every  $\psi \in \epsilon\mathbb{B}(\mathcal{T}_N)$  there exists  $\xi_0 \in \mathbb{R}^m$  such that the (unique) solution  $\xi(t)$  of (3.45) originating at  $\xi(0) = \xi_0$  satisfies  $v(t) = \theta(\xi(t)) = \psi(t)$  for all  $t \in \mathbb{R}_{\geq 0}$ . Then  $m \geq 2N + 1$ .

**Lemma 3.3.** *Let  $K \subset \mathbb{R}^2$  be a compact set including 0. For each  $\epsilon > 0$  and each  $N \in \mathbb{N}$  there exists  $\delta > 0$  such that, for every  $\psi \in \delta\mathbb{B}(\mathcal{T}_N)$  there exists  $c_\psi \in \mathcal{C}^0(\mathbb{R}^2, \mathbb{R})$  satisfying  $\sup_{k \in K} |c_\psi(k)| < \epsilon$  such that  $c_\psi(\sin(t), \cos(t)) = \psi(t)$ .*

Based on previous results, the proof of Theorem 3.8 relies then on the construction of an *ad hoc* set of perturbations of  $F$  which makes impossible for the regulator to generate all the possible corresponding steady state control actions. We remark that in all the elements of this perturbation set, the function of the exosystem  $s$  is kept equal to the nominal value  $s^\circ$ . Thus, we are conceptually in the same setting of Theorem 3.1, in which the extended plant is linear and only the plant is perturbed, with the only difference that in this setting arbitrarily small nonlinear perturbations are allowed.

## 3.4 Infinite-dimensional internal model regulators

### 3.4.1 Internal model design

In view of the results of previous chapter, consider now single-input single-output systems (3.2) that can be written, under suitable change of coordinates as in (3.38), namely

$$\Sigma_x^{\text{INF}} : \begin{cases} \dot{w} = s(w) \\ \dot{\zeta} = \varphi(w, \zeta, e) \\ \dot{e} = q(w, \zeta, e) + u \end{cases} \quad (3.46)$$

in which  $\zeta \in \mathbb{R}^{n_\zeta}$  is the state of the zero-dynamics,  $e \in \mathbb{R}$  is the measured output to be regulated to zero and  $u \in \mathbb{R}$  is the control input, and  $w \in \mathbb{R}^{n_w}$  are the exosignals.

Note that we suppose that the system has unitary relative-degree between the input  $u$  and the regulated output  $e$ . The case of higher relative degree will be addressed below. The main idea consists in adopting a high-gain observer as shown below in Section 3.4.1.2 We state now the following assumptions.

**Assumption 3.10.** *Consider system (3.46). The functions  $\varphi, q$  are  $\mathcal{C}^2$ , the function  $q$  is globally Lipschitz and moreover the zero-dynamics of  $\Sigma_p^{\text{INF}}$  is globally incrementally ISS with respect to  $w$  and  $e$ , namely, for any two initial conditions  $\zeta'(0), \zeta''(0) \in \mathbb{R}^{n_\zeta}$  and any two pair of inputs  $(w', e')$  and  $(w'', e'')$ , the corresponding solutions  $\zeta', \zeta''$  to  $\dot{\zeta} = \varphi(w, \zeta, e)$  satisfy*

$$|\zeta'(t) - \zeta''(t)| \leq \beta(|\zeta'(0) - \zeta''(0)|, t) + \sup_{s \in [0, t]} \gamma_w(|w'(s) - w''(s)|) + \sup_{s \in [0, t]} \gamma_e(|e'(s) - e''(s)|)$$

for some  $\beta \in \mathcal{KL}$  and  $\gamma_w, \gamma_e \in \mathcal{K}_\infty$ , for all  $t \geq 0$ .

We remark that Assumption 3.10 can be verified for instance under the well-known Demidovich condition (see, e.g., [69, 152, 207])

$$P \frac{\partial \varphi}{\partial \zeta}(w, \zeta, e) + \frac{\partial \varphi}{\partial \zeta}^\top(w, \zeta, e)P \preceq -Q.$$

Then, consider the steady-state trajectories  $\mathcal{O}_{\Sigma_{\zeta w}}$  of the zero-dynamics of system (3.46) when  $e = 0$ , namely

$$\Sigma_{\zeta w} : \begin{cases} \dot{w} = s(w) \\ \dot{\zeta} = \varphi(w, \zeta, 0). \end{cases} \quad (3.47)$$

We make the following assumption.

**Assumption 3.11.** *There exist a skew-adjoint operator  $\mathcal{S} : D(\mathcal{S}) \subset \mathcal{H} \rightarrow \mathcal{H}$ , with  $D(\mathcal{S})$  dense in  $\mathcal{H}$  and a (possibly unbounded) operator  $\mathcal{E} \in \mathfrak{L}(D(\mathcal{S}), \mathbb{R})$  such that, for any element  $(w^\circ, z^\circ) \in \mathcal{O}_{\Sigma_{\zeta w}}$  and any initial time  $t_0 \in \mathbb{R}$  there exist an initial condition  $v_0 \in D(\mathcal{S})$  such that the function  $\varphi(t) := -q(w^\circ(t), \zeta^\circ(t), 0)$  satisfies for all  $t \geq t_0$*

$$\begin{aligned} \dot{v}(t) &= \mathcal{S}v(t), & v(0) &= v_0, \\ \mathcal{E}v(t) &= \varphi(t). \end{aligned}$$

We define now the family  $\mathcal{F}$  as a set of  $\mathcal{C}^2$  functions such that any element  $f \in \mathcal{F}$  satisfies Assumptions (3.10) and (3.11). Then, we let  $\tau_{\mathcal{F}}$  be the the weak  $\mathcal{C}^1$  topology (Example 3.7) on a compact set  $\mathbf{P} := \mathbf{X} \times \mathbf{U}$  with  $\mathcal{D} \subset \mathbf{X}$ , and let  $\tau_{\mathcal{X}}$  be the Hausdorff topology on  $\mathcal{X}$ .

Finally, we consider the asymptotic regulation property  $\mathcal{P}_0$  defined in (3.12), that is, in our context

$$\mathcal{P}_0 := \text{“ } \forall \xi \in \mathcal{O}, \forall t \in \text{dom } \xi, e(t) = 0 \text{”}. \quad (3.12)$$

Based on previous assumptions, we consider now the following linear infinite-dimensional regulator

$$\Sigma_c^{\text{INF}} : \begin{cases} \dot{\eta}_{\text{im}} = \mathcal{S}\eta_{\text{im}} + \mathcal{G}e \\ u = -\kappa e + \mu \mathcal{M}^*(\eta_{\text{im}} - \mathcal{M}e) \end{cases} \quad (3.48)$$

where the  $\mathcal{S} : D(\mathcal{S}) \subset \mathcal{H} \rightarrow \mathcal{H}$  is defined as in Assumption 3.11,  $\mathcal{G} : \mathfrak{L}(\mathbb{R}, \mathcal{H})$  is a bounded operator to be chosen so that the pair  $(\mathcal{S}^*, \mathcal{G}^*)$  is approximately observable in infinite time (see Definition 2.6) and  $\mathcal{M} : \mathbb{R} \rightarrow \mathcal{H}$  is a bounded linear operator selected as the solution to the (infinite-dimensional) Sylvester equation

$$-\kappa \mathcal{M} = \mathcal{S}\mathcal{M} + \mathcal{G}, \quad (3.49)$$

and  $\mathcal{M}^* : \mathcal{H} \rightarrow \mathbb{R}$  is its adjoint operator. Note that since  $\mathcal{S}$  is a skew-symmetric operator, for any  $\kappa > 0$  the spectrum of  $-\kappa$  and  $\mathcal{S}$  are disjoint and therefore the solution to (3.49) is unique, see, e.g. [153, Lemma 22]. Also,  $\mathcal{M}$  takes values in  $\mathcal{H}$  as remarked in [D53]. Note that once the internal model  $\eta_{\text{im}}$  dynamics is fixed, the design of the stabilizer part in  $\Sigma_c^{\text{INF}}$  follows from the forwarding technique developed for the stabilization of cascade ODE-PDE systems in Section 2.3. We have now the following result.

**Theorem 3.9.** *Suppose that Assumptions 3.10-3.11 hold and moreover suppose that the pair  $(\mathcal{S}^*, \mathcal{G}^*)$  is approximately observable according to Definition 2.6. Then, there exists a  $\kappa^* > 0$  such that, for any  $\kappa > \kappa^*$  and any  $\mu > 0$ , the regulator  $\Sigma_c^{\text{INF}}$  is  $(\mathcal{P}_0, \tau)$ -robust at  $F^\circ, X^\circ$  for the strong solutions<sup>9</sup> of the closed-loop system (3.46), (3.48). In other words, the following holds.*

<sup>9</sup>Actually one can also prove existence of weak solutions when asking  $\eta_{\text{im}}(0) \in \mathcal{H}$ . Since the PDE is part of the regulator, we focus in this case only to initial conditions guaranteeing existence of strong solutions.

- For any initial condition  $(w(0), \zeta(0), e(0), \eta_{\text{im}}(0)) \in W \times \mathbb{R}^{n_z} \times \mathbb{R} \times D(\mathcal{S})$  the closed-loop system  $\Sigma_x^{\text{INF}}\text{-}\Sigma_c^{\text{INF}}$  defined in (3.46), (3.48) admits a unique strong solution  $(w, \zeta, e, \eta_{\text{im}})$  in

$$C^1([t_0, +\infty); \mathbb{R}^{n_w} \times \mathbb{R}^{n_\zeta} \times \mathbb{R} \times \mathcal{H}) \cup C^0([t_0, +\infty); \mathbb{R}^{n_w} \times \mathbb{R}^{n_\zeta} \times \mathbb{R} \times D(\mathcal{S}))$$

which is bounded for all  $t \geq t_0$ , namely there exists  $\delta > 0$  such that  $|w(t)| + |\zeta(t)| + |e(t)| + \|\eta(t)\|_{D(\mathcal{S})} \leq \delta$  for all  $t \geq 0$ .

- For any initial condition  $(w(0), \zeta(0), e(0), \eta_{\text{im}}(0)) \in W \times \mathbb{R}^{n_\zeta} \times \mathbb{R} \times D(\mathcal{S})$ , solutions to the closed-loop system  $\Sigma_x^{\text{INF}}\text{-}\Sigma_c^{\text{INF}}$  defined in (3.46), (3.48) satisfy  $\lim_{t \rightarrow \infty} e(t) = 0$ .

Previous theorem establishes that the regulator (3.48) solves the global output regulation problem for systems of the form (3.46) robustly with respect to classes of functions satisfying Assumptions 3.10, 3.11. While Assumption 3.10 is concerned only with stability properties of the zero-dynamics, Assumption 3.11 can be seen as more critical as it defines the class of signals that the internal-model unit needs to generate at steady-state. As extensively discussed in Section 3.3, Assumption 3.11 is actually quite generic and “robust”. For instance, when  $w$  converges to a  $T$ -periodic signal, then the signal  $q(w, z, 0)$  is also a  $T$ -periodic signal due to the  $\delta$ ISS properties of the zero-dynamics (3.47). For this reason, under such an assumption, the explicit knowledge of the functions  $f, q$  is not needed and the design is robust to any variations of within the family  $\mathcal{F}$  as long as the stability requirement is met.

In the next section we investigate Assumption 3.11 in the context of quasi-periodic signals providing an explicit design for the operators  $\mathcal{S}, \mathcal{G}, \mathcal{M}$  in (3.48).

### 3.4.1.1 Internal models for quasi-periodic signals

Suppose that the signal  $\varphi$  in Assumption 3.11 is quasi-periodic and can be written as

$$\varphi(t) = \sum_{i=1}^N \varphi_i(t), \quad \varphi_i(t + T_i) = \varphi_i(t), \quad \forall t \geq 0, \quad (3.50)$$

namely as a sum of  $N$  signals in which each  $\varphi_i$  is  $T_i$ -periodic. Moreover, we suppose that the periods  $T_i$  are incommensurable real numbers, namely  $\frac{T_i}{T_j}$  is an irrational number for any pair of  $i, j$ ,  $i \neq j$ . For  $N = 1$ , we fall in the context of repetitive control, e.g. [D19] or [208] and references therein. A generator of  $\tau$ -periodic signals can be obtained by using a transport equation as follows:

$$\begin{aligned} \partial_t \phi(t, x) &= -\frac{1}{\tau} \partial_x \phi(t, x), \quad \forall (t, x) \in \mathbb{R} \times [0, 1], \\ \phi(t, 1) &= \phi(t, 0), \quad \forall t \in \mathbb{R}. \end{aligned}$$

As a consequence, Assumption 3.11 is verified in the context of quasi-periodic signals by selecting the operators  $\mathcal{S}, \mathcal{E}$  as

$$\mathcal{S}v := -\Lambda \partial_x v, \quad \mathcal{E}v := \mathbf{1}v(t, 1),$$

with  $D(\mathcal{S}) = \{v \in \mathcal{H} : v(0) = v(1)\}$  with  $\mathcal{H} := L^2([0, 1]; \mathbb{R}^N)$ ,

$$\Lambda := \text{diag} \left( \frac{1}{T_1}, \dots, \frac{1}{T_N} \right) \quad (3.51)$$

and with  $\mathbf{1}$  being a row vector in which any element is equal to 1, namely  $\mathbf{1} := (1, \dots, 1)$ . In other words, for any continuous function  $\varphi$  in (3.50) and any  $t_0 \in \mathbb{R}$ , there exists an initial condition  $v(t_0) = v_0$  such that  $\varphi(t) = \mathcal{E}v(t)$  for all  $t \geq t_0$ . Note that in this case  $\mathcal{E}$  is an unbounded operator.

Then, the operators  $\mathcal{S}$ ,  $\mathcal{G}$  and  $\mathcal{M}$  of internal model unit (3.48) can be taken as

$$\mathcal{S}\eta := -\Lambda\partial_x\eta, \quad \mathcal{G}e := B(x)e, \quad \mathcal{M}e := M(x)e \quad (3.52)$$

with  $\Lambda$  defined in (3.51),  $B : [0, 1] \rightarrow \mathbb{R}^N$  defined as

$$B(x) := \text{col}(\beta_1 \exp(T_1 x), \dots, \beta_N \exp(T_N x)),$$

and  $M : [0, 1] \rightarrow \mathbb{R}^N$  defined as the solution of the following two-boundary value problem

$$\begin{aligned} \Lambda M'(x) &= \kappa M(x) + B(x), \\ M(0) &= M(1), \end{aligned}$$

corresponding to the Sylvester equation (3.49). Note that  $M$  is a column vector and its  $i$ -th component can be explicitly computed as

$$\begin{aligned} M_i(x) &= \begin{cases} \exp(\kappa T_i x) \bar{M}_i + \beta_i \frac{\exp(T_i x) - \exp(\kappa T_i x)}{T_i(1-\kappa)}, & \kappa \neq 1, \\ \exp(\kappa T_i x) \bar{M}_i + x \beta_i \exp(\kappa T_i x), & \kappa = 1, \end{cases} \\ \bar{M}_i &= \begin{cases} \frac{\beta_i}{T_i(1-\kappa)} \frac{\exp(T_i) - \exp(\kappa T_i)}{1 - \exp(\kappa T_i)}, & \kappa \neq 1, \\ \frac{\exp(\kappa T_i)}{1 - \exp(\kappa T_i)} \beta_i, & \kappa = 1. \end{cases} \end{aligned} \quad (3.53)$$

Moreover, the adjoint  $\mathcal{M}^*$  of  $M$  is defined as

$$\mathcal{M}^*\eta = \int_0^1 M(x)^\top \eta(t, x) dx.$$

With this notation, the internal-model regulator (3.48) takes the more explicit form

$$\Sigma_c^{\text{QP}} : \begin{cases} \partial_t \eta(t, x) = -\Lambda \partial_x \eta(t, x) + B(x)e(t) \\ \eta(t, 1) = \eta(t, 0) \\ u(t) = -\kappa e(t) + \mu \int_0^1 M(x)^\top (\eta(t, x) - M(x)e(t)) dx, \end{cases} \quad (3.54)$$

defined on  $(t, x) \in \mathbb{R} \times [0, 1]$ , and with state variable  $\eta$  taking initial condition in  $L^2([0, 1]; \mathbb{R}^N)$ . We remark that the operator  $\mathcal{G}$  so defined (3.52) is bounded, allowing to guarantee ISS properties with respect to  $e$ . With such a choice, one can deal with systems possessing a relative degree larger than one and add a high-gain observer (estimating the derivatives of the output  $e$ ) so that to obtain a pure output feedback design shown in the next section.

In the next lemma, we show that the pair  $\mathcal{S}, \mathcal{G}$  so defined satisfies the conditions of Theorem 3.9.

**Lemma 3.4.** *Let  $\beta_i \neq 0$  for all  $i \in [1, \dots, N]$  and let  $(T_1, \dots, T_N)$ , with  $T_i \neq 0$  for all  $i \in [1, \dots, N]$  be a set of incommensurable scalars, namely  $\frac{T_i}{T_j}$  is an irrational number for any pair of  $i, j \in [1, \dots, N]$ ,  $i \neq j$ . Then, the pair  $(\mathcal{S}^*, \mathcal{G}^*)$  defined in (3.52) is approximately observable in infinite time.*

Note that the regulator so designed solves the strong asymptotic version of the robust arbitrary harmonics regulation problem addressed in Section 3.2.3.3 for the class of minimum-phase systems (3.46).

### 3.4.1.2 Non-unitary relative degree

We consider in this section the case of systems that have a non-unitary relative degree. In particular, we suppose that the relative degree is  $r > 1$  and the system reads

$$\Sigma_p^{\text{INF},r} : \begin{cases} \dot{\zeta} = \varphi(w, \zeta, \xi_1), \\ \dot{\xi}_i = \xi_{i+1}, & i = 1, \dots, r-1 \\ \dot{\xi}_r = q(w, \zeta, \xi_1, \dots, \xi_r) + u, \\ e = \xi_1, \end{cases} \quad (3.55)$$

It is well known that system  $\Sigma_p^{\text{MIN},r}$  can be put into a system of the form  $\Sigma_p^{\text{MIN}}$  via the following change of coordinates

$$\theta := \xi_r + \sum_{i=1}^{r-1} g^{r-i} a_i \xi_i,$$

which transform system  $\Sigma_p^{\text{MIN},r}$  into

$$\begin{cases} \dot{\zeta} = \varphi(w, \zeta, g^{1-r} C_{r-1} \xi) \\ \dot{\xi} = g(A_{r-1} - B_{r-1} K_a) \xi + g B_{r-1} \theta \\ \dot{\theta} = \Delta(w, \zeta, \xi, \theta) + u \\ e = C_{r-1} \xi \end{cases}$$

with the following definitions

$$A_i := \begin{pmatrix} 0_{i-1,1} & I_{i-1} \\ 0 & 0 \dots 0 \end{pmatrix}, \quad B_i := \begin{pmatrix} 0_{i-1,1} \\ 1 \end{pmatrix}, \quad C_i := \begin{pmatrix} 1 & 0_{1 \times i-1} \end{pmatrix}, \quad K_a = (a_1, \dots, a_{r-1}), \\ K_b = (b_1, \dots, b_r), \\ \Delta(w, \zeta, \xi, \theta) := q(w, \zeta, g^{1-r} \xi_1, \dots, g^{-1} \xi_{r-1}, \theta - K_a \xi) + g \sum_{i=1}^{r-2} a_i \xi_{i+1} + g a_{r-1} (\theta - \sum_{i=1}^{r-1} a_i \xi_i).$$

It can be remarked that the signal  $\theta$  is not directly available but since it is a linear combination of the output  $e$  and its  $r$  derivatives, it can be estimate via a high-gain observer [115] of the form

$$\begin{cases} \dot{\hat{\xi}}_i = \hat{\xi}_i + g^i b_i (e - \hat{\xi}_1), & i = 1 \dots, r-1 \\ \dot{\hat{\xi}}_r = g^r b_r (e - \hat{\xi}_1). \end{cases}$$

where  $g \geq 1$  is the so-called high-gain parameter and selecting

$$\hat{\theta} := \hat{\xi}_r + \sum_{i=1}^{r-1} g^{r-i} a_i \hat{\xi}_i.$$

As a consequence, collecting all together the equations, under Assumptions 3.10, 3.11, a regulator for system (3.55) takes the overall form

$$\Sigma_c^{\text{INF-HGO}} : \begin{cases} \dot{\eta}_{\text{im}} = \mathcal{S} \eta_{\text{im}} + \mathcal{G} \hat{\theta} \\ \dot{\eta}_{\text{st}} = A_r \eta_{\text{st}} + D_g K_b (e - C_r \eta_{\text{st}}) - \kappa B_r \hat{\theta} \\ u = -\kappa \hat{\theta} + \mu \mathcal{M}^* (\eta_{\text{im}} - \mathcal{M} \hat{\theta}) \\ \hat{\theta} = \eta_{\text{st},r} + \sum_{i=1}^{r-1} g^{r-i} a_i \eta_{\text{st},i} \end{cases}$$

in which  $D_g = \text{diag}(g, \dots, g^r)$ , the parameters  $a_i, i = 1, \dots, r-1$  and  $b_i, i = 1, \dots, r$  are selected so that the following characters tic poly nominal

$$\begin{aligned} p_a(\lambda) &:= \lambda^{r-1} + a_{r-1}\lambda^{r-2} + \dots + a_2\lambda + a_1 \\ p_b(\lambda) &:= \lambda^r + b_r\lambda^{r-1} + \dots + b_2\lambda + b_1 \end{aligned}$$

have all eigenvalues with negative real part,  $g, \kappa$  are high-gain parameters to be chosen large enough and  $\mu > 0$ .

### 3.4.2 Finite-dimensional approximation

In Section 3.4.1 we have shown that a possible approach to the problem of robust output regulation (with asymptotic steady-state properties) is to rely on the use of infinite-dimensional regulators. Evidently, because of their infinite-dimensional nature, such controllers are not implementable from a practical point of view and needs to be discretized. We talk more in general of realization as such a discretization can be done in several different ways (e.g., time and/or spatial discretizations). In this section, inspired by the design of Section 3.4.1.1 we focus therefore on the case of an infinite-dimensional regulator described by a single transport equation for the reject/tracking of periodic signals. In particular, the regulator (3.48) has the form

$$\Sigma_c^{\text{RC}} : \begin{cases} \partial_t \eta(t, x) = -\frac{1}{T} \partial_x \eta(t, x) + \exp(\beta x) e(t) \\ \eta(t, 1) = \eta(t, 0) \\ u(t) = -\kappa e(t) + \mu \int_0^1 M(x)^\top (\eta(t, x) - M(x) e(t)) dx, \end{cases} \quad (3.56)$$

with  $M : [0, 1] \rightarrow \mathbb{R}$  solution of the following two-boundary value problem

$$\begin{cases} \frac{1}{T} M'(x) = \kappa M(x) + \exp(\beta x), \\ M(0) = M(1). \end{cases} \quad (3.57)$$

An explicit solution can be computed similarly to (3.53). The controller  $\Sigma_c^{\text{RC}}$  is also known as Repetitive Controller, e.g. [51, 97] and [D4, D19].

In order to discretize the infinite-dimensional dynamics in  $\Sigma_c^{\text{RC}}$ , we remark that the operator  $\mathcal{S}$  defined as

$$\begin{aligned} \mathcal{S} &= \partial_x, & \begin{cases} \partial_t \eta(t, x) = -\frac{1}{T} \partial_x \eta(t, x) \\ \eta(t, 1) = \eta(t, 0) \end{cases} \\ D(\mathcal{S}) &= \{\eta \in L^2(0, 1) : \eta(0) = \eta(1)\}, \end{aligned}$$

is a skew-adjoint operator whose eigenvalues lies on the imaginary axes. Furthermore they are given by  $0 \cup \{\pm i \frac{2\ell\pi}{T}\}$  for any  $\ell \in \mathbb{N}_{>0}$ . As a consequence, a simple manner to obtain an approximated finite-dimensional realization of  $\mathcal{S}$  is to use the transfer function

$$G_{n_o}(s) = \frac{1}{s \prod_{\ell=1}^{n_o} (s^2 + \ell\omega^2)}, \quad \omega = \frac{2\pi}{T},$$

in which only the first  $2n_o + 1$  eigenvalues of the operator  $\mathcal{S}$  are considered. In state-space representation, the regulator  $\Sigma_c^{\text{RC}}$  is then approximate as follows the form

$$\Sigma_c^{\text{RC}, n_o} : \begin{cases} \dot{\eta}_{\text{im}} = \Phi \eta_{\text{im}} + \Gamma e \\ u = -\kappa e + \mu M^\top N (\eta_{\text{im}} - M e), \end{cases} \quad (3.58)$$

where  $\eta_{\text{im}} = (\eta_0, \dots, \eta_{n_o}) \in \mathbb{R}^{n_{\text{im}}}$ ,  $n_{\text{im}} = 2n_o + 1$  is the state internal model unit and the matrices  $\Phi, N, \Gamma$  are defined as

$$\begin{aligned}
 \Phi &:= \text{blkdiag}(0, \Phi_1, \dots, \Phi_{n_o}), & \Phi_\ell &= \begin{pmatrix} 0 & \omega_\ell \\ -\omega_\ell & 0 \end{pmatrix}, & \omega_\ell &= \frac{2\ell\pi}{T} \\
 N &= \text{blkdiag}(\bar{n}_0, N_1, \dots, N_{n_o}), & N_\ell &= \bar{n}_\ell I_2, & \forall \ell &= 1, \dots, n_o, \\
 M &= (1, M_1^\top, \dots, M_{n_o}^\top)^\top, & M_\ell &= (1, 0)^\top, & \forall \ell &= 1, \dots, n_o, \\
 \Gamma &= -(\Phi + \sigma I)M.
 \end{aligned} \tag{3.59}$$

where  $\bar{n}_\ell$  is a sequence of real numbers satisfying, for some  $\bar{N} \in \mathbb{R}_{>0}$ ,

$$\sum_{\ell=0}^{\infty} \bar{n}_\ell = \bar{N}^2 < +\infty, \tag{3.60a}$$

$$\bar{n}_{(\ell+1)} < \bar{n}_\ell \quad \forall 0 \leq \ell, \tag{3.60b}$$

$$\ell \bar{n}_\ell \leq m \bar{n}_m \quad \forall (\ell, m) : 0 < m \leq \ell, \tag{3.60c}$$

$$\ell^2 \bar{n}_\ell \leq m^2 \bar{n}_m \quad \forall (\ell, m) : 0 \leq \ell \leq m. \tag{3.60d}$$

Actually, as an illustration or for more specificity, we consider the particular case

$$\begin{aligned}
 n_{z0} &= 2, \\
 \bar{n}_\ell &= \frac{1}{\ell^{1+\epsilon}}, \quad \forall \ell \in \mathbb{N}_{>0} \quad \epsilon \in (0, 1].
 \end{aligned} \tag{3.61}$$

The resulting controller (3.58) is a finite-dimensional approximation of the exact infinite dimensional (repetitive-controller) regulator (3.56). Due to its finite-dimensional nature it cannot guarantee asymptotic regulation, namely  $\mathcal{P}_0$  as defined in Example 3.3

$$\mathcal{P}_0 := \text{“ } \forall \xi \in \mathcal{O}, \forall t \in \text{dom } \xi, e(t) := h_e(w(t), x_p(t)) = 0 \text{”}.$$

However, due to its structure, harmonic regulation is always guaranteed, see (3.18) that we recall here:

$$\mathcal{P}_T := \text{“ } \forall \xi \in \mathcal{O}_{\Sigma_{\text{cl}}(F, X)}(X \times X_c), e \in \mathcal{Q}_{N_o}^{n_e} \text{”}. \tag{3.18}$$

Actually, the regulator  $\Sigma_c^{\text{RC}, n_o}$  in (3.58) can be also tuned to solve a even thinner approximate objective. As a matter of fact, it can be shown that the regulator  $\Sigma_c^{\text{RC}, n_o}$  satisfies

$$\int_0^T |e(t)|^2 dt \leq \frac{\psi_2}{(n_o + 1)^2}. \tag{3.62}$$

As a consequence given a desired objective  $\varepsilon$ , one can select the dimension  $n_o$  of the regulator  $\Sigma_c^{\text{RC}, n_o}$  in order so that any steady-state trajectory of the closed-loop system (3.46), (3.58) satisfy the following regulation objective  $\mathcal{P}_{T, \varepsilon}$ :

$$\mathcal{P}_{T, \varepsilon} := \text{“ } \forall \xi \in \mathcal{O}, \forall t \in \text{dom } \xi, \int_0^T |h_e(w(t), x_p(t))|^2 dt \leq \varepsilon \text{”}. \tag{3.63}$$

Note that such a property is similar to the one defined Example 3.3, but now defined on the  $L_2$  norm of the regulated output and not on the  $L_\infty$  norm.



To this end, consider a plant of the form (3.46), namely namely

$$\Sigma_x^{\text{RC}, n_o} : \begin{cases} \dot{w} = s(w) \\ \dot{\zeta} = \varphi(w, \zeta, e) \\ \dot{e} = q(w, \zeta, e) + u \end{cases} \quad (3.64)$$

and let us state the following (strong) minimum-phase assumption.

**Assumption 3.12.** *The functions  $(s, \varphi, q)$  are  $\mathcal{C}^2$  and there exists a compact set  $\mathcal{A} \subset \mathbb{R}^{n_w} \times \mathbb{R}^{n_\zeta}$  which is locally exponentially stable for the zero-dynamics*

$$\dot{w} = s(w), \quad \dot{\zeta} = \varphi(w, \zeta, 0)$$

with an open domain of attraction  $\mathcal{D} \supset \mathcal{A}$ .

Similarly to Section 3.2.3.2, we let  $\mathcal{F} = \mathcal{F}_w \times \mathcal{F}_p$ , where  $\mathcal{F}_w$  is a set of  $\mathcal{C}^1$  functions  $\mathbb{R}^{n_w} \rightarrow \mathbb{R}^{n_w}$  and  $\mathcal{F}_p$  is a set of  $\mathcal{C}^2$  functions of the form  $(\varphi, q)$ , with  $\varphi : \mathbb{R}^{n_w} \times \mathbb{R}^{n_\zeta} \times \mathbb{R} \rightarrow \mathbb{R}^{n_\zeta}$  and  $q : \mathbb{R}^{n_w} \times \mathbb{R}^{n_\zeta} \times \mathbb{R} \rightarrow \mathbb{R}$ . We endow  $\mathcal{F}_w$  with an arbitrary topology  $\tau_{\mathcal{F}_w}$  and, with a  $\mathbf{X} \subset \mathbb{R}^{n_w} \times \mathbb{R}^{n_\zeta} \times \mathbb{R}$  arbitrarily large compact neighborhoods of the origin satisfying  $\mathbf{X} \subset \mathcal{D} \times \mathbb{R}$ , we endow  $\mathcal{F}_p$  with the subset topology  $\tau_{\mathcal{F}_p}$  induced by the weak  $\mathcal{C}^2$  topology on  $\mathbf{X}$  (see Example 3.7). Note that in this case, due to the linearity in  $u$  we don't consider perturbations in  $u$  but only on the functions  $\varphi$  and  $q$ . We then let  $\tau_{\mathcal{F}} := \tau_{\mathcal{F}_w} \times \tau_{\mathcal{F}_p}$ . This allows us to consider “independent variations” of  $s$  and  $(\varphi, q)$ , and thus to better distinguish the assumptions on the exosystem from that on the controlled plant. The following assumption is state concerning the exosystem dynamics.

**Assumption 3.13.** *There exists a  $\tau_{\mathcal{F}_w}$ -neighborhood  $\mathcal{N}_w$  of  $s^\circ$  and, for every  $\epsilon > 0$ , a  $\delta(\epsilon) > 0$ , such that every solution to (3.19) with  $s \in \mathcal{N}_w$  and satisfying  $|w(0)| \leq \delta(\epsilon)$  also satisfies  $|w(t)| \leq \epsilon$  for all  $t \geq 0$ . Moreover, the solutions to (3.19) with  $s \in \mathcal{N}_w$  satisfy uniformly*

$$\lim_{t \rightarrow \infty} |w(t+T) - w(t)| = 0.$$

Then, we let  $\mathcal{X} = \mathcal{K}(\mathbb{R}^{n_x})$ , and we endow it with the Hausdorff topology  $\tau_{\mathcal{X}}$  (see Example 3.5). Finally, we consider the regulator  $\Sigma_c^{\text{RC}, n_o}$  defined in (3.58) which is parametrized by three parameters: its dimension  $n_o$  and two gains  $\mu, \kappa > 0$ . We consider a compact set of initial condition  $E_0 \subset \mathbb{R}^{n_{\text{im}}}$  parameterized by any  $\mathbf{z} > 0$  such that

$$\eta_{\text{im}}^\top(0) N \eta_{\text{im}}(0) \leq \mathbf{z}.$$

This is always possible to the choice of  $N$  which is in  $\ell^2$ . We then have the following result.

**Theorem 3.10.** *Suppose that Assumptions 3.12 and 3.13 hold. For  $\kappa \geq 1$  large enough and any  $\mu > 0$ , the regulator (3.58) is  $(\mathcal{P}_T, \tau_{\mathcal{F}} \times \tau_{\mathcal{X}})$ -robust at  $(F^\circ, \{0\})$ , with  $\mathcal{P}_T$  defined in (3.18), uniformly in the parameter  $n_o$ . Furthermore, for any  $\epsilon > 0$  there exists  $n_o \in \mathbb{N}$  large enough such that the regulator (3.9) is  $(\mathcal{P}_{T,\epsilon}, \tau_{\mathcal{F}} \times \tau_{\mathcal{X}})$ -robust at  $(F^\circ, \{0\})$ , with  $\mathcal{P}_{T,\epsilon}$  defined in (3.63).*

Theorem 3.10 establishes several properties about the solutions of the closed-loop system (3.64), (3.58). Similarly to Section 3.2.3.2, the regulator  $\Sigma_c^{\text{RC}, n_o}$  is able to guarantee harmonic regulation of order  $n_o$ . The remarkable feature however is that the regulator guarantees a domain of attraction which is uniform in the plant's initial conditions. In other words, there exists a  $\kappa$  large enough such that the set  $\mathbf{X}$  is always included in the domain of attraction for any number of oscillators  $n_o$  included in  $\Sigma_c^{\text{RC}, n_o}$ . Furthermore, the trivial initial condition

$\eta_{\text{im}}(0) = 0$  coinciding with the origin, is always included in the domain of attraction of the closed-loop system. Notably, once  $\kappa$  is fixed, one can vary the dimension  $n_{\text{im}}$  of the internal model unit without need of modifying the gain  $\kappa$ .

The second remarkable feature of the regulator  $\Sigma_c^{\text{RC}n_o}$  is that by increasing the dimension one can improve the  $L_2$  norm of the steady-state trajectory of the regulated output  $e$ . In particular, given any  $\varepsilon > 0$  one can select a sufficiently large number of oscillators  $n_o$  such that (3.62) is satisfied at steady-state. As this property is uniform, one can therefore recover

$$\lim_{n_o \rightarrow \infty} \lim_{t \rightarrow \infty} \int_t^{t+T} |e(t)|^2 dt = 0$$

namely asymptotic regulation is achieved. In other words, when letting the number  $n_o$  go to infinity, one recovers the exact repetitive controller  $\Sigma_c^{\text{RC}}$  defined in (3.56). And this property holds without needs of increasing  $\kappa$  to infinity (as one could alternatively do in a pure high-gain feedback paradigm).

### 3.5 Conclusions and perspectives

The problem of robust output regulation for nonlinear systems has been investigated. First, in Sections 3.1-3.3, we proposed a new framework able to clarify the robustness properties of internal-model based regulators. The development of these sections is mainly based on the articles [D37, D38], although it takes profit of many other contributions, some of them under revision at the time of the writing of this manuscript. More in details, Section 3.2.4 is a summary of the various design techniques proposed in the series of works [D25, D28, D46–D48], while the first part of Section 3.3 concerning the robustness properties of nonlinear internal model based regulators will be published in [D35]. Then, in Section 3.4, we introduced the use of infinite-dimensional regulators for robust regulation. The first part of this section is based on the contribution [D3] under revision at the time of writing of this manuscript and generalizes the work on repetitive control [D19]. The content of Section 3.4.1.2 has been published in [D4, D29], while the last part in which we establish a clear link between repetitive control and harmonic regulation summarizes the main results from [D27, D29].

This chapter proposed a new set of results in the literature of robust output regulation. On the one hand, we clarified the notion of robustness of linear and nonlinear internal models proposing a detailed framework able to capture the complexity of steady-state behaviours. On the other hand, we introduced the use of infinite dimensional regulators for nonlinear systems clarifying the repetitive control approach *vis-à-vis* output regulation literature. Furthermore, we showed that infinite dimensional internal models can potentially guarantee robust asymptotic properties for much larger classes of exosignals, such as those that can be represented by a sum of non-commensurable periodic signals, namely quasi-periodic ones. Although the proposed regulators are not implementable because of their infinite-dimensional nature, they represent a starting point for the design of large scale regulators able to achieve practical regulation in a non-high-gain feedback paradigm. In other words, we believe that the practical objective of approximate regulation can be obtained not by increasing a high-gain parameter but by appropriately discretizing (spatially and or temporally) the infinite-dimensional regulator and by tuning its dimension. A preliminary result, in such a direction, is proved in the context of periodic signals, where we showed that a spectral decomposition based on Fourier series allows to reduce the asymptotic  $L^2$  norm of the regulated output without need of increasing the high-gain parameter [D29], but by increasing the numbers of eigenvalues on the imaginary axe, namely the dimension of the internal-model regulator. A detailed study will be also dedicated to the case

of quasi-periodic signals to better detail the results of Section 3.2.3.3 so that to characterize the dimension of the resulting finite-dimensional regulator needed to guarantee desired asymptotic bounds on the regulated output. It would be also interesting to study the connection of the proposed framework with the harmonic approach recently proposed in [34, 172] based on the use of a sliding Fourier decomposition.

# 4

## Performances improvement in observers

---

### Contents

---

<b>4.1 Preliminaries on hybrid systems</b> . . . . .	<b>86</b>
<b>4.2 Stubborn and dead-zone redesign</b> . . . . .	<b>87</b>
4.2.1 Problem Statement . . . . .	87
4.2.2 Stubborn Redesign . . . . .	89
4.2.3 Dead-zone redesign . . . . .	91
<b>4.3 Constrained state estimation</b> . . . . .	<b>93</b>
4.3.1 Continuous-time systems . . . . .	93
4.3.2 Discrete-time and hybrid approaches . . . . .	96
<b>4.4 Uniting observers</b> . . . . .	<b>98</b>
4.4.1 Problem statement . . . . .	98
4.4.2 Assumptions . . . . .	100
4.4.3 Main result . . . . .	104
<b>4.5 Multi-observers approach</b> . . . . .	<b>105</b>
4.5.1 Problem statement . . . . .	106
4.5.2 Hybrid estimation scheme . . . . .	107
4.5.3 Main result . . . . .	110
<b>4.6 Conclusions and perspectives</b> . . . . .	<b>113</b>

---

State observers are the basic instrument to detect abnormal operating conditions such as faults or malfunctions and feed controllers when not all the state variables are accessible, [D34]. While state estimation for linear systems is a well studied topic, beginning with the seminal papers by Kalman [111] and Luenberger [132], many different approaches for nonlinear systems are still under development. See, among others, [27, 38, 96, 115, 184], [D14, D16, D25]. However, most of these approaches focus on the convergence properties of the estimation error in nominal conditions, that is, when the plant’s model is known perfectly and when no measurement noise is affecting the outputs. Indeed, at present, few tools are available to analyze the effect of the measurement noise on the estimation error in a nonlinear context. Most of the existing works follow a “worst-case approach” such as  $H_\infty$  gains, Lyapunov bounds or input-to-state stability gains. An attempt to address high-frequency measurement noise was recently investigated for high-gain observers [D15]. Depending on the characteristics of the measurement noise, different approaches may be pursued to improve the observer performances. For instance, in the

case of output measurements affected by outliers, that is, perturbations of impulsive nature affecting the measurement for a very short time, the majority of the existing methods focus on a discrete-time representation and mainly deal with identification problems, see, e.g., [3, 70, 218] and the references therein. When considering high-frequency measurement noise, a number of high-gain approaches have been developed, see, e.g., [2, 36, 43, 198, 202], [D13, D14, D30]. These techniques, however, strongly exploit the particular structure of the observer at hand and can be difficult to extend to other approaches. To the best of the authors' knowledge, a general methodology to improve the sensitivity to measurement noise applicable to a broad class of estimators is still missing.

The objective of this chapter is therefore that of addressing the problem of improving performances in observers design by proposing a series of different approaches and techniques to overcome with different issues. Most of techniques relies on the use of hybrid systems approach [90]. Such a formalism is therefore recalled in Section 4.1. The first technique that we propose is detailed in Section 4.2, where a stubborn and dead zone redesign approach is proposed. Such a technique is based on the use of saturation/dead zone with variable thresholds and can be applied to any observer possessing some ISS properties. Such a redesign allows to considerably improve the performances of the original observer in the presence of impulsive or persistent measurement noise. Then, in Section 4.3 we address the problem of constrained state estimation. In particular, we propose a (possibly hybrid) redesign approach which allows to constrain the state of an observer in a given convex set while preserving its performance inside of it. Finally, the problem of uniting multiple observers is studied. In Section 4.4 we study the particular case of combining two given observer, one possessing only local convergence properties (such as an Extended Kalman Filter) with good steady-state performances, and another one possessing global stability properties with possible poor steady-state performances (such a high-gain observer). This framework is then further extended in Section 4.5 by allowing to combine  $N$  observers (some of them possibly even not converging) in order to improve the performances of a nominal given one.

## 4.1 Preliminaries on hybrid systems

In most parts of this chapter we will consider hybrid systems with state  $x \in \mathcal{X} \subseteq \mathbb{R}^{n_x}$  and input  $u \in \mathcal{U} \subseteq \mathbb{R}^{n_u}$  in the formalism of [48], [90], in particular described by systems of the form

$$\mathcal{H} : \begin{cases} \dot{x} = F(x, u), & (x, u) \in \mathcal{C} \times \mathcal{U}, \\ x^+ = G(x, u), & (x, u) \in \mathcal{D} \times \mathcal{U}, \end{cases} \quad (4.1)$$

where  $\mathcal{C} \subseteq \mathcal{X}$  is the flow set,  $\mathcal{D} \subseteq \mathcal{X}$  is the jump set,  $F$  is the flow map and  $G$  is the jump map. Solutions to system (4.1) are defined on *hybrid time domains*. A set  $E \subset \mathbb{R}_{\geq 0} \times \mathbb{Z}_{> 0}$  is a *compact hybrid time domain* if  $E = \bigcup_{j=0}^J ([t_j, t_{j+1}], j)$  for some finite sequence of times  $0 = t_0 \leq t_1 \leq \dots \leq t_{J+1}$  and it is a *hybrid time domain* if for all  $(T, J) \in E$ ,  $E \cap ([0, T] \times \{0, 1, \dots, J\})$  is a compact hybrid time domain. On each hybrid time domain we use the natural ordering relation  $(t_0, j_0) \preceq (t_1, j_1)$  if  $t_0 + j_0 \leq t_1 + j_1$ . Given a hybrid time domain  $E$ , we define  $\sup_t E := \sup\{t \in \mathbb{R}_{\geq 0} : \exists j \in \mathbb{Z}_{\geq 0} \text{ such that } (t, j) \in E\}$ ,  $\sup_j E := \sup\{j \in \mathbb{Z}_{\geq 0} : \exists t \in \mathbb{R}_{\geq 0} \text{ such that } (t, j) \in E\}$ . A hybrid signal is a function defined on a hybrid time domain. A hybrid signal  $u : \text{dom } u \rightarrow \mathcal{U}$  is called a hybrid input if  $u(\cdot, j)$  is measurable and locally essentially bounded for each  $j$ . A hybrid signal  $x : \text{dom } x \rightarrow \mathcal{X}$  is called a hybrid arc if  $x(\cdot, j)$  is locally absolutely continuous for each  $j$ . A hybrid arc  $x : \text{dom } x \rightarrow \mathcal{X}$  and a hybrid input  $u : \text{dom } u \rightarrow \mathcal{U}$  is a solution pair  $(x, u)$  to  $\mathcal{H}$  in if  $\text{dom } x = \text{dom } u$ ,  $(x(0, 0), u(0, 0)) \in (\mathcal{C} \cup \mathcal{D}) \times \mathcal{U}$ , and

- for all  $j \in \mathbb{Z}_{\geq 0}$  and almost all  $t$  such that  $(t, j) \in \text{dom } x$ ,  $(x(t, j), u(t, j)) \in \mathcal{C} \times \mathcal{U}$  and  $\dot{x} = F(x(t, j), u(t, j))$ ;
- for all  $(t, j) \in \text{dom } x$  such that  $(t, j + 1) \in \text{dom } x$ ,  $(x(t, j), u(t, j)) \in \mathcal{D} \times \mathcal{U}$  and  $x(t, j + 1) = G(x(t, j), u(t, j))$ .

A solution pair  $(x, u)$  to  $\mathcal{H}$  is *maximal* if it cannot be extended and it is *complete* if  $\text{dom } x$  is unbounded. In the sequel, each time we talk of solutions we mean maximal solutions.

Given any hybrid signal  $w : \text{dom } w \rightarrow \mathbb{R}^{n_w}$ , we define

$$\|w\|_{\infty} := \max \left\{ \text{ess. sup}_{(t,j) \in \text{dom } w \setminus \Gamma(w)} |w(t, j)|, \sup_{(t,j) \in \Gamma(w)} |w(t, j)| \right\}$$

where  $\Gamma(w)$  denotes the set of all  $(t, j) \in \text{dom } w$  such that  $(t, j + 1) \in \text{dom } w$ . By adopting the same notation, we denote by  $(x, u)$  a solution pair, with the  $x$ -component initialized in  $\mathcal{X}$  and control  $u$  taking values in  $\mathcal{U}$ , to a differential equation of the form  $\dot{x} = f(x, u)$ , with state  $x \in \mathcal{X} \subseteq \mathbb{R}^{n_x}$  and input  $u \in \mathcal{U} \subseteq \mathbb{R}^{n_u}$ . Given any continuous signal  $w : [0, \infty) \rightarrow \mathbb{R}^{n_w}$ , we define  $\|w\|_{\infty} := \sup_{t \in [0, \infty)} |w(t)|$ .

## 4.2 Stubborn and dead-zone redesign

In this section we introduce a systematic procedure to redesign a given observer or filter in order to improve its performances in some noisy scenarios. We suppose that the estimator has already been designed and it satisfies some mild, possibly local, input-to-state stability (ISS) properties [184, 185]. Then, we propose two different methodologies to redesign the output injection term, both of them preserving ISS. The first one, called *stubborn redesign*, was first introduced in the context of linear systems [5, 6], and high-gain observers [D5]. It consists in adding an adaptive saturation to the output injection error in the observer dynamics so as to reduce the sensitivity to measurement outliers. The second one, called *dead-zone redesign*, generalizes the works [59, 60] for Luenberger and high-gain observers, where a “dead-zonated” output injection with a dynamically-adapted dead band enables mitigating the effect of bounded and persistent measurement noise. The two designs can be also combined. The novelty of these approaches is that the saturation/dead-zone levels are not fixed but they are dynamically adjusted to obtain desirable properties. For instance, the stubborn redesign well addresses the presence of sporadic measurement outliers. The saturation threshold regulates the trimming action on the output injection term by shrinking it to zero, thereby making the observer increasingly “stubborn” about its current estimate [D5], [6]. In this way, possible outliers do not directly reach the error dynamics because they are mitigated by the limiting effect of the saturation. On the other hand, persistent estimation errors gradually cause an increase of the saturation threshold and become increasingly important in the error dynamics, so as to guarantee ISS for the estimation error dynamics. The same analysis is accomplished for the dead-zone redesign, i.e., by considering estimators with a dead-zonated output injection, well suited to improving the rejection of persistent bounded measurement noise [60].

### 4.2.1 Problem Statement

Consider a generic nonlinear system of the form

$$\dot{x} = f(x, u) + w, \quad y = h(x) + v, \quad (4.2)$$

where  $x \in \mathbb{R}^n$  is the state,  $u \in \mathbb{R}^p$  is a known input,  $y \in \mathbb{R}^m$  is the measured output,  $w \in \mathbb{R}^n$  is some external disturbance, and  $v \in \mathbb{R}^m$  represents the sensor measurement noise. For system (4.2) we suppose to know an observer providing an asymptotic estimate  $\hat{x}$  of state  $x$  of the form

$$\begin{aligned}\dot{z} &= \varphi(z, u) + G\kappa(z, y - h(\hat{x})), \\ \hat{x} &= \psi(z)\end{aligned}\tag{4.3}$$

where  $z \in \mathcal{Z} \subseteq \mathbb{R}^\rho$ , with  $\rho$  integer such that  $\rho \geq n$ , is the state of the observer, and  $\hat{x} \in \mathbb{R}^n$  is the estimate of  $x$ . The functions  $\varphi : \mathbb{R}^\rho \times \mathbb{R}^p \rightarrow \mathbb{R}^\rho$ ,  $\kappa : \mathbb{R}^\rho \times \mathbb{R}^m \rightarrow \mathbb{R}^\rho$ , and  $\psi : \mathbb{R}^\rho \rightarrow \mathbb{R}^n$  are locally Lipschitz and  $G$  is a matrix of dimension  $\rho \times \rho$ . Function  $\kappa$  denotes the output injection term and is such that  $\kappa(z, 0) = 0$  for all  $z \in \mathbb{R}^\rho$ , which ensures that the origin is an equilibrium point for the error dynamics in the absence of disturbances. The matrix  $G$  is a selection matrix encompassing the fact that the output injection term  $\kappa$  might affect only part of the  $z$  dynamics, as in the case of Kalman-like filters. The following assumption is then stated.

**Assumption 4.1.** *There exist  $\mathcal{X}_0 \subseteq \mathcal{X} \subseteq \mathbb{R}^n$ ,  $\mathcal{U} \subseteq \mathbb{R}^p$ , and a compact set  $\mathcal{W} \subset \mathbb{R}^n$  such that the trajectories of (4.2), with initial conditions in  $\mathcal{X}_0$ , input  $u(t) \in \mathcal{U}$ , and disturbances  $w(t) \in \mathcal{W}$  for all  $t \geq 0$ , remain in  $\mathcal{X}$  for all  $t \geq 0$ .*

Our redesign approach is based on conditioning the output injection term in (4.3) by way of suitable nonlinearities comprising saturations and deadzones. These redesign methods essentially perturb the output injection term  $\kappa$  in (4.3) in ways that are well represented by the following version of observer (4.3) with *perturbed injection*

$$\begin{aligned}\dot{z} &= \varphi(z, u) + G\kappa(z, y - h(\hat{x})) + Gd, \\ \hat{x} &= \psi(z)\end{aligned}\tag{4.4}$$

where  $d \in \mathbb{R}^\rho$  is a generic disturbance affecting the observer dynamics in directions matching the input channel of  $\kappa$  (that is, through the same matrix  $G$ ). We ask observer (4.3) to be ISS w.r.t. the disturbances  $w, v$  affecting the plant (4.2) and w.r.t. the disturbance  $d$  acting on the observer (4.4) according to the following property.

**Property 4.1.** *Observer (4.3) is an ISS observer for system (4.2) on  $\mathcal{Z} \subseteq \mathbb{R}^\rho$  if there exist a locally Lipschitz function  $V : \mathcal{X} \times \mathcal{Z} \rightarrow \mathbb{R}_{\geq 0}$  satisfying  $V(x, z) \geq 0$  for all  $(x, z) \in \mathcal{X}, \mathcal{Z}$ , functions  $\underline{\alpha}, \bar{\alpha} \in \mathcal{K}_\infty$ , a right inverse  $\psi^{-R}$  of function  $\psi$ , namely a function satisfying*

$$x = \psi(\psi^{-R}(x)), \quad \forall x \in \mathcal{X},$$

*compact sets  $\mathcal{V} \subset \mathbb{R}^m$ ,  $\mathcal{D} \subset \mathbb{R}^\rho$ , and constants  $\bar{\kappa}, c, c_v, c_w, c_d > 0$  such that the following inequalities hold*

$$|G| \leq 1, \quad |\kappa(z, y_1) - \kappa(z, y_2)| \leq \bar{\kappa}|y_1 - y_2|,\tag{4.5}$$

$$\underline{\alpha}(|x - \psi(z)|) \leq V(x, z) \leq \bar{\alpha}(|\psi^{-R}(x) - z|),\tag{4.6}$$

$$\dot{V} \leq -cV(x, z) + c_v|v| + c_w|w| + c_d|d|,\tag{4.7}$$

*for all  $(x, z, u, v, w, d) \in \mathcal{X} \times \mathcal{Z} \times \mathcal{U} \times \mathcal{V} \times \mathcal{W} \times \mathcal{D}$ , and  $y_1, y_2 \in \mathbb{R}^m$ , along the dynamics of system (4.2) interconnected with the perturbed-injection observer (4.4).*

Condition (4.5) of Property 4.1 states that function  $\kappa(z, \cdot)$  is globally Lipschitz uniformly in  $z \in \mathcal{Z}$ . Conditions (4.6) and (4.7) state that (4.4) is an asymptotic observer for system (4.2)

and that the estimation error  $|x - \hat{x}|$  is input-to-state stable<sup>1</sup> w.r.t. the measurement noise  $v$  and disturbances  $w, d$ , namely there exists  $\beta \in \mathcal{KL}$ ,  $\vartheta \in \mathcal{K}_\infty$  such that all solutions  $t \mapsto (x(t), z(t))$  belonging to  $\mathcal{X} \times \mathcal{Z}$  for all  $t \geq 0$  satisfy

$$|\hat{x}(t) - x(t)| \leq \beta(|\psi^{-R}(x(0)) - z(0)|, t) + \vartheta(\|v\|_\infty + \|w\|_\infty + \|d\|_\infty).$$

Motivated by [184], the above stated ISS property is coordinate-dependent when  $\mathcal{X}$  and  $\mathcal{U}$  are unbounded. It is thus emphasized that guaranteeing Property 4.1 may require selecting a clever set of coordinates. Next, we suppose that the ISS-Lyapunov function  $V$  of Property 4.1 satisfies the following output-growth condition.

**Property 4.2.** *There exist constants  $\ell_0, \ell_1, \ell_v, \ell_w, \ell_d > 0$  such that the following holds for system (4.2), observer (4.4), and function  $V$  of Property 4.1 with  $\hat{x} = \psi(z)$ ,*

$$|h(x) - h(\hat{x})| \leq \ell_0 V(x, z), \quad (4.8a)$$

$$|D^+(h(x) - h(\hat{x}))| \leq \ell_1 V(x, z) + \ell_v |v| + \ell_w |w| + \ell_d |d|, \quad (4.8b)$$

for all  $(x, z) \in \mathcal{X} \times \mathcal{Z}$ ,  $u \in \mathcal{U}$  and all  $(v, w, d) \in \mathcal{V} \times \mathcal{W} \times \mathcal{D}$ .

Condition (4.8) requires that  $V$ , which is an ISS-Lyapunov function for the estimation error  $|x - \hat{x}|$ , has the same growth as the output error function  $|h(x) - h(\hat{x})|$ . These two properties are verified by a large number of class of plants/observers as detailed in [D6] such as Luenberger observers, Kalman filters, observers for input-affine systems, observers for Lipschitz systems, observer based on the circle criterion, high-gain observers, and low-power high-gain observers, For instance, any of the techniques proposed in [4, 12, 20, 27, 29, 36, 36, 38, 84, 96, 115, 117, 132, 165, 184, 202], [D4, D13, D14], enjoy these properties.

## 4.2.2 Stubborn Redesign

The stubborn redesign of observer (4.3) reads as

$$\begin{aligned} \dot{z} &= \varphi(z, u) + G\kappa(z, \text{sat}_\sigma(y - h(\hat{x}))), \\ \dot{\sigma} &= -\Lambda\sigma + \Theta|y - h(\hat{x})|_{\text{cw}}, \\ \hat{x} &= \psi(z), \end{aligned} \quad (4.9)$$

where  $(z, \sigma) \in \mathbb{R}^e \times \mathbb{R}_{\geq 0}^m$  is the state of the stubborn redesigned observer and

$$\Lambda := \text{diag}(\lambda_1, \dots, \lambda_m) > 0, \quad \Theta := \text{diag}(\theta_1, \dots, \theta_m) > 0,$$

are design parameters. It can be noted that observer (4.9) is obtained by saturating the output error  $y - h(\hat{x})$  in (4.3) with a variable saturation level  $\sigma$ . This level is dynamically driven by the same output error  $y - h(\hat{x})$ . The motivation for such a construction is that of filtering, at the steady state, sporadic perturbations that may affect the measured output  $y$ . Since in nominal conditions both the output error  $y - h(\hat{x})$  and the saturation level  $\sigma$  converge asymptotically to zero, when an outlier occurs, the saturation limits its effect on the observer state  $z$ , which is therefore less perturbed. The observer (4.9) preserves the ISS of the original observer (4.3), according to the definitions given in Properties 4.1, 4.2.

<sup>1</sup>The reader is referred to [190] and references therein for more details about the notion of ISS and the existence of ISS-Lyapunov functions.



**Theorem 4.1.** Consider system (4.2) satisfying Assumption 4.1. Suppose observer (4.3) is an ISS observer enjoying Properties 4.1 and 4.2. Let  $\lambda_i > 0$ ,  $i = 1, \dots, m$  be fixed. Then, there exist  $\theta_i^* > 0$ ,  $i = 1, \dots, m$ , such that, for any  $\theta_i > \theta_i^*$ ,  $i = 1, \dots, m$ , observer (4.9) is an ISS observer for system (4.2) enjoying Properties 4.1 and 4.2.

To establish the Theorem 4.1 we used the following non-trivial ISS-Lyapunov function

$$V_e(x, z, \sigma) := V(x, z) + \sum_{i=1}^m \left( \zeta_i \sigma_i + (\zeta_i + \eta) \max\{|\gamma_i| - \sigma_i, 0\} \right),$$

where  $V$  comes from the ISS properties of (4.3) and satisfies Properties 4.1, 4.2, and the parameters  $\zeta_i > 0$ ,  $i = 1, \dots, m$ , and  $\eta > 0$  have to be properly selected.

The effect of the dynamic saturation in (4.9) is that of mitigating the effect of impulsive disturbances (outliers) of  $v$  on the estimation error  $\hat{x} - x$ , thus improving the transient behavior, at the cost of slowing down the convergence rate, yet still preserving the asymptotic estimation. In the linear case, we can also show some further properties of the proposed stubborn redesign. In particular, consider the linear system

$$\dot{x} = Ax + Bu, \quad y = Cx + v \quad (4.10)$$

where  $x \in \mathbb{R}^n$  is the state,  $y \in \mathbb{R}$  is the measured output,  $v$  is the measurement noise, and  $(A, C)$  is an observable pair. The observer for (4.10) is selected as

$$\dot{\hat{x}} = A\hat{x} + Bu + L(y - C\hat{x}) \quad (4.11)$$

where  $\hat{x} \in \mathbb{R}^n$  is the estimate and  $L$  is such that  $A - LC$  is Hurwitz. We denote the estimation error provided by observer (4.11) as  $\tilde{x}_0 := \hat{x} - x$ , thus obtaining

$$\dot{\tilde{x}}_0 = (A - LC)\tilde{x}_0 + Lv. \quad (4.12)$$

By following the design proposed in Theorem 4.1, we consider also the stubborn redesigned observer

$$\begin{aligned} \dot{\hat{x}} &= A\hat{x} + Bu + L \text{sat}_\sigma(y - C\hat{x}), \\ \dot{\sigma} &= -\lambda\sigma + \theta|y - C\hat{x}|, \end{aligned} \quad (4.13)$$

with  $\sigma \in \mathbb{R}_{\geq 0}$ ,  $\lambda, \theta > 0$ . Similarly, we denote the estimation error of observer (4.13) as  $\tilde{x}_{\text{sat}} := \hat{x} - x$ . In these coordinates, we obtain the following error dynamics

$$\begin{aligned} \dot{\tilde{x}}_{\text{sat}} &= A\tilde{x}_{\text{sat}} + L \text{sat}_\sigma(v - C\tilde{x}_{\text{sat}}) \\ \dot{\sigma} &= -\lambda\sigma + \theta|v - C\tilde{x}_{\text{sat}}|. \end{aligned} \quad (4.14)$$

To comparatively characterize the effect of impulsive disturbances  $v$  on the two observers (4.11) and (4.13), we model  $v$  as a piecewise constant perturbation of the form

$$v = \delta_\tau(t) = \begin{cases} \frac{1}{\tau} & 0 \leq t \leq \tau, \\ 0 & t > \tau. \end{cases} \quad (4.15)$$

where  $\delta_\tau(t)$  converges to the Dirac delta function as  $\tau \rightarrow 0^+$ . The following result establishes extreme improvements of the error response  $\tilde{x}_{\text{sat}}$  over  $\tilde{x}_0$  as  $\tau \rightarrow 0^+$  by focusing on  $|\tilde{x}_{\text{sat}}(\tau)|$  and  $|\tilde{x}_0(\tau)|$ . This is relevant because for  $t > \tau$  we have  $\delta_\tau(t) = 0$  and both observers evolve with  $v = 0$ .

**Proposition 4.1.** Consider (4.10) with  $A \in \mathbb{R}^{n \times n}$  nonsingular and denote by  $\tilde{x}_0$  and  $\tilde{x}_{\text{sat}}$  the solutions, respectively, to (4.12) and (4.14) with  $\tilde{x}_0(0) = \tilde{x}_{\text{sat}}(0) = 0$ ,  $\sigma(0) = 0$ , and  $v$  given by (4.15). As  $\tau$  tends to  $0^+$ , the following holds

$$\frac{|\tilde{x}_{\text{sat}}(\tau)|}{|\tilde{x}_0(\tau)|} \leq \tau \theta \frac{1 + o(\tau)}{1 - o(\tau)} \quad (4.16)$$

where  $o(\tau)$  denotes small terms in  $\tau^r$ ,  $r \geq 1$ . Furthermore, for each  $\tau \geq 0$ ,  $|\tilde{x}_{\text{sat}}(t)|$  converges to zero as  $\tau \rightarrow 0^+$ .

While Proposition 4.1 illustrates the advantages of (4.14) versus (4.12) in terms of dynamic response, we can also show that the static response, as measured by the disturbance-to-error DC gain, is not worse in (4.14) when  $\theta \geq \lambda$ .

**Proposition 4.2.** Assume that  $A - LC$  is Hurwitz. For any  $\theta \geq \lambda$ , the disturbance-to-error DC gains of observers (4.11) and (4.13) associated to a constant  $v$  coincide.

### 4.2.3 Dead-zone redesign

The dead-zone redesign of observer (4.3) reads

$$\begin{aligned} \dot{z} &= \varphi(z, u) + G\kappa(z, \text{dz}_\sigma(y - h(\hat{x}))), \\ \dot{\sigma} &= -\Lambda\sigma + \Theta |y - h(\hat{x})|_{\text{cw}}, \\ \hat{x} &= \psi(z), \end{aligned} \quad (4.17)$$

where  $(z, \sigma) \in \mathbb{R}^e \times \mathbb{R}_{\geq 0}^m$  is the state of the dead-zone redesigned observer and

$$\Lambda := \text{diag}(\lambda_1, \dots, \lambda_m) > 0, \quad \Theta := \text{diag}(\theta_1, \dots, \theta_m) \geq 0,$$

are design parameters. Paralleling the stubborn redesign in (4.9), observer (4.17) is obtained by “dead-zonating” the output error  $y - h(\hat{x})$  in (4.3) with a variable dead-zone level  $\sigma$ . The level  $\sigma$  is driven by the same output error  $|y - h(\hat{x})|_{\text{cw}}$ . From the peculiar shape of the dead-zone function, the motivation for this redesign is that of “trimming” the effect of persistent bounded sensor noises.

Note that, despite the presence of the dead-zone, the use of a variable threshold allows retaining the asymptotic convergence to zero of the estimation error in nominal conditions. This is formally stated in the next theorem, where we show that the dead-zone redesigned observer (4.17) preserves the ISS of the original observer (4.3), according to the definitions given in Properties 4.1, 4.2.

**Theorem 4.2.** Consider system (4.2) satisfying Assumption 4.1. Suppose observer (4.3) is an ISS observer enjoying Properties 4.1 and 4.2. Let  $\theta_i \geq 0$ ,  $i = 1, \dots, m$  be fixed. Then, there exist  $\lambda_i^* > 0$ ,  $i = 1, \dots, m$ , such that, for any  $\lambda_i > \lambda_i^*$ ,  $i = 1, \dots, m$ , observer (4.17) is an ISS observer for system (4.2) enjoying Properties 4.1 and 4.2.

The Lyapunov function which is used for Theorem 4.2 takes the form

$$V_e(x, z, \sigma) := V(x, z) + \sum_{i=1}^m \zeta_i \sigma_i$$

for some appropriate selection of the parameters  $\zeta_i > 0$ . As for the stubborn redesign, we analyze here the effect of a constant perturbation  $v(t) = \bar{v}$  for all  $t \geq 0$  on the redesigned

observer (4.17) for the single-output linear case. In particular, we consider once again the single-output linear system (4.10) where  $(A, C)$  is an observable pair, interconnected to the linear observer (4.11), where  $L$  is such that  $A - LC$  is Hurwitz. Denoting the estimation error as  $\tilde{x}_0 := \hat{x} - x$ , we obtain the linear error dynamics (4.12), repeated here for convenience:

$$\dot{\tilde{x}}_0 = (A - LC)\tilde{x}_0 + Lv. \quad (4.18)$$

By following the design proposed in Theorem 4.2, we consider then the dead-zone redesigned observer

$$\begin{aligned} \dot{\hat{x}} &= A\hat{x} + Bu + L \operatorname{dz}_\sigma(y - C\hat{x}) \\ \dot{\sigma} &= -\lambda\sigma + \theta|y - C\hat{x}| \end{aligned} \quad (4.19)$$

with  $\sigma \in \mathbb{R}_{\geq 0}$ ,  $\lambda > 0$ ,  $\theta \geq 0$ . Similarly, we denote the estimation error of observer (4.19) as  $\tilde{x}_{\text{dz}} := \hat{x} - x$ . In these coordinates, we obtain the error dynamics

$$\begin{aligned} \dot{\tilde{x}}_{\text{dz}} &= A\tilde{x}_{\text{dz}} + L \operatorname{dz}_\sigma(v - C\tilde{x}_{\text{dz}}) \\ \dot{\sigma} &= -\lambda\sigma + \theta|v - C\tilde{x}_{\text{dz}}|. \end{aligned} \quad (4.20)$$

We compare then the static responses, as measured by the disturbance-to-error DC gain, of the error dynamics (4.18) and (4.20). For this, we focus on the class of triplets  $A, C, L$  such that  $A$  is nonsingular and the gain  $CA^{-1}L < 1$ . This condition is not overly restrictive and is enjoyed by all triplets  $A, C, L$  such that both  $A$  and  $A - LC$  are Hurwitz, as illustrated by the next lemma.

**Lemma 4.1.** *All the triplets  $(A, C, L)$  such that  $\det(A - LC)\det(A) > 0$ , satisfy  $CA^{-1}L < 1$ , in particular this condition holds if  $A$  and  $A - LC$  are both Hurwitz.*

We may now state our main DC-gain result by establishing a desirable strict decrease of the DC gain of (4.19) as  $\theta$  is increased from 0 (in this case the dead-zone is inactive and the DC gains are the same) to its maximum value.

**Proposition 4.3.** *Suppose that  $A - LC$  is Hurwitz. If  $A$  is invertible and  $CA^{-1}L < 1$ , then there exists a class  $\mathcal{K}$  function  $\tilde{k}$  such that, for any  $\lambda > \theta \geq 0$ , the disturbance-to-error DC gains  $k_0, k_{\text{dz}}$  of dynamics (4.18), respectively (4.20), satisfy*

$$\frac{k_{\text{dz}}}{k_0} = 1 - \tilde{k}\left(\frac{\theta}{\lambda}\right). \quad (4.21)$$

## Mixed design

Finally, as a conclusion of this section, we remark that an appealing feature of the parallel previous developments of is that the corresponding redesigns preserve Properties 4.1 and 4.2. Due to this fact, it is immediate to apply a mixed stubborn dead-zone redesign by nesting the two approaches as follows<sup>2</sup>

$$\begin{aligned} \dot{z} &= \varphi(z, u) + G\kappa(z, \operatorname{sat}_{\sigma_S}(\operatorname{dz}_{\sigma_D}(y - h(\hat{x})))) , \\ \dot{\sigma}_S &= -\Lambda_S\sigma_S + \Theta_S|y - h(\hat{x})|_{\text{cw}} , \\ \dot{\sigma}_D &= -\Lambda_D\sigma_D + \Theta_D|y - h(\hat{x})|_{\text{cw}} , \\ \hat{x} &= \psi(z) , \end{aligned} \quad (4.22)$$

where  $(z, \sigma_S, \sigma_D) \in \mathbb{R}^e \times \mathbb{R}_{\geq 0}^m \times \mathbb{R}_{\geq 0}^m$  is the redesigned observer state and

$$\begin{aligned} \Lambda_S &:= \operatorname{diag}(\lambda_{S1}, \dots, \lambda_{Sm}), & \Theta_S &:= \operatorname{diag}(\theta_{S1}, \dots, \theta_{Sm}), \\ \Lambda_D &:= \operatorname{diag}(\lambda_{D1}, \dots, \lambda_{Dm}), & \Theta_D &:= \operatorname{diag}(\theta_{D1}, \dots, \theta_{Dm}), \end{aligned}$$

<sup>2</sup>Evidently, we can also select  $\kappa(z, \operatorname{dz}_{\sigma_S}(\operatorname{sat}_{\sigma_D}(y - h(\hat{x}))))$  in (4.22).

with  $\Lambda_S, \Theta_S, \Lambda_D > 0$  and  $\Theta_D \geq 0$  are design parameters. The mixed redesign allows achieving both the desirable features of the saturation and dead-zone redesigns, discussed in the previous sections, while preserving the ISS-properties of the original observer (4.3).

### 4.3 Constrained state estimation

In most real control applications, the state of the plant evolves in some given compact set  $\mathcal{X}$  describing the set of interest of the variables. However, unless the observation problem is formulated as a constrained optimization problem from the start [168], the estimated state generated by the observer could in principle leave the set  $\mathcal{X}$  for some time, because of transient dynamics or perturbations. These excursions outside  $\mathcal{X}$  may be significant in terms of amplitude (e.g. peaking phenomenon) and time, and may lead to the next issues.

- (Accuracy) When the estimate is outside  $\mathcal{X}$ , the information provided by the observer is likely to be inaccurate and so potentially unexploitable by the user. A typical example is the peaking phenomenon occurring in high-gain observers [115].
- (Aberrant estimates) The state estimate may violate the physics of the plant. To give an example, when the concentrations of Lithium-ion in the electrodes of an electrochemical battery are estimated, e.g. [35], it may occur that the estimated concentrations generated by the observer are negative for some time, which is physically impossible. This is the case in general for positive systems (see, e.g., [76]).
- (Implementation issues) When implementing an observer on an embedded systems, we often need to specify the range of the estimated states, and this range may be limited.
- (Destabilization) It may lead to instability in output feedback designs, see e.g. [115].
- (Existence of observer dynamics) The observer dynamics may not be well defined outside the set  $\mathcal{X}$ . This issue is typical when the observer is not implemented in the same coordinates of the plant dynamics, see, e.g., [26, 133], [D24, D25].

In order to solve the aforementioned problem, we propose a new paradigm based on a convexity assumptions and a gradient-based algorithm, which allows to constrain the state of the observer in a desired set while preserving its performances in terms of Lyapunov inequalities. The proposed paradigm can be used in the context of continuous-time, discrete-time and hybrid systems/observers.

#### 4.3.1 Continuous-time systems

Here we consider instead a different approach based on a gradient-based algorithm under a convexity assumption. We consider a plant modelled as

$$\dot{x} = f(t, x, u, d), \quad y = h(t, x, u, d), \quad (4.23)$$

with state  $x \in \mathbb{R}^{n_x}$ , known input  $u \in \mathbb{R}^{n_u}$ , output  $y \in \mathbb{R}^{n_y}$ , and where  $d \in \mathbb{R}^{n_d}$  is an unknown perturbation acting on the dynamics and/or the measurement, with  $n_x, n_u, n_y, n_d \in \mathbb{N}$ . We suppose that the plant state  $x$  is evolving in a compact set as precised below.

**Assumption 4.2.** ?? *There exist subsets  $\mathcal{X}_0 \subset \mathbb{R}^{n_x}$ ,  $\mathcal{U} \subset \mathbb{R}^{n_u}$ ,  $\mathcal{D} \subset \mathbb{R}^{n_d}$ , and a compact subset  $\mathcal{X} \subset \mathbb{R}^{n_x}$ , such that any trajectory of  $\mathcal{P}$  initialized in  $\mathcal{X}_0$ , with input in  $\mathcal{U}$  and perturbation in  $\mathcal{D}$ , remains in  $\mathcal{X}$  for all forward times.*

**Assumption 4.3.** ?? The convex hull of  $\mathcal{X}$  is strictly included in  $\hat{\mathcal{X}}$ , i.e., there exists a compact convex set  $\mathcal{C} \in \mathbb{R}^{n_x}$  satisfying  $\mathcal{X} \subseteq \mathcal{C} \subset \hat{\mathcal{X}}$ .

**Lemma 4.2.** Suppose Assumption ?? holds. Then, there exist  $\varrho \in \mathbb{R}_{>0}$ , an integer  $n_c \in \mathbb{N}$ , and a  $C^1$  function  $c : \mathbb{R}^{n_x} \rightarrow \mathbb{R}_{\geq 0}^{n_c}$  such that, by defining

$$\mathcal{C}_0 := \{x \in \mathbb{R}^{n_x} : c(x) = 0\}, \quad \mathcal{C}_\varrho := \{x \in \mathbb{R}^{n_x} : |c(x)| \leq \varrho\},$$

the following holds:

- a)  $\mathcal{X} \subseteq \mathcal{C}_0 \subset \mathcal{C}_\varrho \subset \hat{\mathcal{X}}$ .
- b) For any  $i = 1, \dots, n_c$ , the  $i$ -th component  $c_i : \mathbb{R}^{n_x} \rightarrow \mathbb{R}_{\geq 0}$  of  $c$  is convex.

**Lemma 4.3.** Consider a  $C^1$  function  $c : \mathbb{R}^{n_x} \rightarrow \mathbb{R}_{\geq 0}^{n_c}$  satisfying item b) of Lemma 4.2. Then, for all  $(x, \hat{x}) \in \mathbb{R}^{n_x} \times \mathbb{R}^{n_x}$  such that  $c(x) = 0$ , we have

$$-c(\hat{x})^\top \frac{dc}{dx}(\hat{x})(\hat{x} - x) \leq -c(\hat{x})^\top c(\hat{x}) \leq 0.$$

Possible choices of the function  $c$  are given as follows.

**Polytopic approach.** When the set  $\mathcal{X}$  can be enveloped in a polytope, namely when there exist vectors  $a_i \in \mathbb{R}^{n_x}$  and scalars  $b_i$ ,  $i = 1 \dots n_c$ , satisfying

$$\mathcal{X} \subseteq \bigcap_{i=1}^{n_c} \{x \in \mathbb{R}^{n_x} : a_i^\top x \leq b_i\} \subset \hat{\mathcal{X}},$$

then the function  $c$  in Lemma 4.3 can be selected as follows

$$c(x) := (c_1(x), \dots, c_i(x), \dots, c_{n_c}(x)), \quad c_i(x) := \max \left\{ a_i^\top x - b_i, 0 \right\}^2.$$

**Ellipsoide approach.** When the set  $\mathcal{X}$  can be enveloped in an ellipse, namely when there exist a positive definite matrix  $Q$  of dimension  $n_x \times n_x$ , a scalar  $r > 0$  and a vector  $x_0 \in \mathbb{R}^{n_x}$

$$\mathcal{X} \subseteq \{x \in \mathbb{R}^{n_x} : (x - x_0)^\top Q(x - x_0) \leq r\} \subset \hat{\mathcal{X}},$$

then the function  $c$  can be selected as

$$c(x) := \max \left\{ \frac{(x - x_0)^\top Q(x - x_0)}{r} - 1, 0 \right\}^2.$$

Next, we consider a continuous-time observer of the form

$$\dot{\hat{x}} = F(t, \hat{x}, u, y), \tag{4.24}$$

with state  $\hat{x} \in \mathbb{R}^{n_x}$  and suppose that system (4.23) and observer (4.24) satisfy some regularity properties as stated in the next assumption.

**Assumption 4.4.** The following is satisfied:

- The function  $h$  in (4.23) is bounded in its first argument and the set  $\mathcal{Y} := h(\mathbb{R}_{\geq 0}, \mathcal{X}, \mathcal{U}, \mathcal{D})$  is compact.
- The function  $F$  is bounded on  $\mathbb{R}_{\geq 0} \times \hat{\mathcal{X}} \times \mathcal{U} \times \mathcal{Y}$ .

- The solutions of (4.24) exist forward in time for any initial condition  $\hat{x}(0) \in \mathcal{X}$ , any input  $u$  in  $\mathcal{U}$  and any output  $y$  of system (4.24), i.e. no finite-escape time phenomenon is possible.

Furthermore, we assume that the observer (4.24) has been designed so that the following assumption is verified.

**Assumption 4.5.** *There exist a (possibly time varying) known matrix  $P(t) = P(t)^\top > 0$ , differentiable in  $t$ , real numbers  $\bar{\lambda} > \underline{\lambda} > 0$ , and a function  $\beta_c : \mathbb{R}_{\geq 0} \times \mathbb{R}^{n_x} \times \mathbb{R}^{n_x} \times \mathbb{R}^{n_u} \times \mathbb{R}^{n_d} \rightarrow \mathbb{R}$ , such that, by defining*

$$V(t, x, \hat{x}) := (\hat{x} - x)^\top P(t)(\hat{x} - x), \quad (4.25)$$

the following is satisfied

$$\begin{aligned} \underline{\lambda}|x - \hat{x}|^2 &\leq V(t, x, \hat{x}) \leq \bar{\lambda}|x - \hat{x}|^2 \\ L_{\mathcal{F}}V(t, x, \hat{x}, u, d) &\leq \beta_c(t, x, \hat{x}, u, d) \end{aligned} \quad (4.26)$$

for all  $(t, x, \hat{x}, u, d) \in \mathbb{R}_{\geq 0} \times \mathcal{X} \times \mathbb{R}^{n_x} \times \mathcal{U} \times \mathcal{D}$ , with

$$\mathcal{F}(t, x, \hat{x}, u, d) := (1, f(t, x, u, d), F(t, \hat{x}, u, h(t, x, u, d))).$$

Assumption 4.5 characterizes the performances of observer (4.24) in terms of the function  $V$  and the supply rate  $\beta_c$ . For instance, for an exponentially stable observer which is input-to-state stable (ISS) with respect to the perturbation, the function  $\beta_c$  in (4.26) is typically of the form  $\beta_c(t, x, \hat{x}, u, d) = -\rho_c V(t, x, \hat{x}) + \alpha_c(|d|)$ , with  $\rho_c > 0$  and  $\alpha_c \in \mathcal{K}$ . In this case,  $V$  is the Lyapunov function associated to the estimation error  $x - \hat{x}$  and  $\rho_c$  is the convergence rate. Note that, when the matrix  $P$  is constant,  $\bar{\lambda}$  and  $\underline{\lambda}$  correspond to the maximum and minimum eigenvalues of  $P$ , respectively. Assumption 4.5 covers a large class of observers for the design of  $\mathcal{O}$  in (4.24), such as linear Luenberger observers [132], high-gain nonlinear observers [115], [D14], observer designs based on linear parameter-varying-like techniques or the circle criterion, e.g., [20, 221], Kalman filters [111] and Kalman-like observers [28, 29] with a time-varying  $P$ . The objective of constrained estimation with preservation of performances is defined as follows.

**Problem 4.1.** *Design a map  $F_m : \mathbb{R} \times \mathbb{R}^{n_x} \times \mathbb{R}^{n_u} \times \mathbb{R}^{n_y}$  such that the following holds.*

1. *For any initial condition  $(x(0), \hat{x}(0)) \in \mathcal{X}_0 \times \mathcal{X}$ , any input in  $\mathcal{U}$  and perturbation in  $\mathcal{D}$ , the corresponding trajectory of the modified observer*

$$\dot{\hat{x}} = F_m(t, \hat{x}, u, y) \quad (4.27)$$

*remains in  $\hat{\mathcal{X}}$  for all  $t \geq 0$ .*

2. *The Lyapunov function (4.25) satisfies*

$$L_{\mathcal{F}_m}V(t, x, \hat{x}, u, d) \leq \beta_c(t, x, \hat{x}, u, d) \quad (4.28)$$

*for any  $(t, x, \hat{x}, u, d) \in \mathbb{R}_{\geq 0} \times \mathcal{X} \times \hat{\mathcal{X}} \times \mathcal{U} \times \mathcal{D}$ , with  $\beta_c$  coming from Assumption 4.5 and*

$$\mathcal{F}_m(t, x, \hat{x}, u, d) := (1, f(t, x, u, d), F_m(t, \hat{x}, u, h(t, x, u, d))).$$

Hence, by solving Problem 4.1, the state estimate generated by observer  $\mathcal{O}_m$  remains in set  $\hat{\mathcal{X}}$  and property (4.26) is preserved for  $\mathcal{O}_m$  as desired. To this end, we modify the dynamics of observer (4.24) as follow

$$F_m(t, \hat{x}, u, y) := F(t, \hat{x}, u, y) + M(t, \hat{x}) \quad (4.29)$$

where function  $M$  is defined by

$$M(t, \hat{x}) := -\gamma_c P(t)^{-1} \frac{dc}{dx}(\hat{x})^\top c(\hat{x}) \quad (4.30)$$

with  $c$  defined in Lemma 4.2,  $P$  given by Assumption 4.5, and  $\gamma_c \in \mathbb{R}_{>0}$  a parameter to be chosen large enough. Note that the knowledge of the supply rate  $\beta_c$  is not needed for the design of  $F_m$  in (4.29).

**Theorem 4.3.** *Suppose Assumptions 4.4 and 4.5 hold and that  $\delta_{\min}$ . Then, there exists  $\gamma_c^* \geq 0$  such that, for any  $\gamma_c > \gamma_c^*$ , Problem 4.1 is solved with  $F_m$  defined in (4.29), (4.30).*

The role of  $\gamma_c$  in (4.30) is to correct the vector field  $F$  when the latter becomes too large and makes the estimate leave the set  $\mathcal{X}$ . To do that, we have to select a constant gain  $\gamma_c$  whose magnitude is large enough with respect to the maximal norm of  $F$  on the boundary of  $\mathcal{C}_\varrho$ . This bound may be subject to some conservatism and in practice  $\gamma_c$  can be adapted online to compensate for the “current” value of  $F$ , by taking for instance

$$\gamma_c(t, \hat{x}, u, y) := \frac{2\bar{\lambda}|F(t, \hat{x}, u, y)|}{\max \left\{ \left| \frac{dc}{dx}(\hat{x})^\top c(\hat{x}) \right|, \delta_{\min} \right\}}$$

for any  $(t, \hat{x}, u, y) \in \mathbb{R} \times \mathbb{R}^{n_x} \times \mathcal{U} \times \mathcal{Y}$ .

Note that the correction term  $M$  defined in (4.30) may also be interpreted as an element of the normal cone to the level set of  $c$  in the metric defined by  $P(t)$ , thus suggesting a link with the *projected dynamics* used in [98] for constant metric  $P$ .

### 4.3.2 Discrete-time and hybrid approaches

The previous approach can be used also for different classes of dynamical systems, namely for discrete-time systems and for hybrid systems. For instance, consider a system of the form

$$x_{k+1} = g(k, x_k, u_k, d_k), \quad y_k = h(k, x_k, u_k, d_k), \quad (4.31)$$

and an observer given by

$$\hat{x}_{k+1} = G(k, \hat{x}_k, u_k, y_k) \quad (4.32)$$

with  $G : \mathbb{R}_{\geq 0} \times \mathbb{R}^{n_x} \times \mathcal{U} \times \mathbb{R}^{n_y} \rightarrow \mathbb{R}^{n_x}$ , under the following assumption.

**Assumption 4.6.** *There exist a (possibly time-varying) known matrix  $P_k = P_k^\top > 0$  for all  $k \in \mathbb{N}$ , real numbers  $\bar{\lambda} > \underline{\lambda} > 0$  and a continuous function  $\beta_d : \mathbb{N} \times \mathbb{R}^{n_x} \times \mathbb{R}^{n_x} \times \mathbb{R}^{n_u} \times \mathbb{R}^{n_d} \rightarrow \mathbb{R}_{\geq 0}$ , such that, by defining*

$$V_k(x, \hat{x}) := (\hat{x} - x)^\top P_k (\hat{x} - x),$$

*the following inequalities hold for all  $(k, x, \hat{x}, u, d) \in \mathbb{N} \times \mathcal{X} \times \mathbb{R}^{n_x} \times \mathcal{U} \times \mathcal{D}$*

$$\begin{aligned} \underline{\lambda} |\hat{x} - x|^2 &\leq V_k(x, \hat{x}) \leq \bar{\lambda} |\hat{x} - x|^2, \\ V_{k+1}(x_{k+1}, \hat{x}_{k+1}) &\leq \beta_d(k, x, \hat{x}, u, d) \end{aligned}$$

*with the compact notation  $x_{k+1} := g(k, x, u, d)$ ,  $\hat{x}_{k+1} := G(k, \hat{x}, u, h(k, x, u, d))$ .*

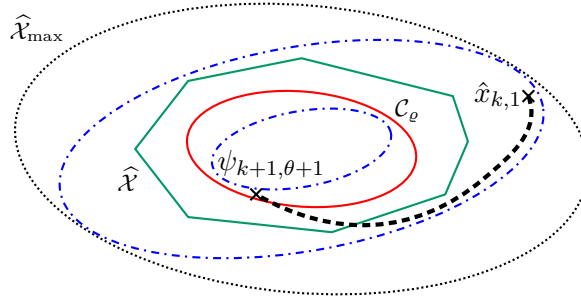

Figure 4.1: Refining strategy (4.34) with (4.36), starting from  $\hat{x}_{k,1} = G(k, \hat{x}_k, u_k, y_k)$ . Dash-dotted blue ellipses: Lyapunov level sets of  $V_{k+1}$ . Red ellipsoid:  $\mathcal{C}_\rho$ . Green polygon:  $\hat{\mathcal{X}}$ . Dotted black ellipse:  $\hat{\mathcal{X}}_{\max}$ , a compact set where the solution is proved to remain. Dashed black line: path of  $\hat{x}_{k,i+1} = \psi_{k,i}(\hat{x}_{k,i})$ ,  $i = 1, \dots, \theta$ .

Similarly to the continuous-time case, it is possible to redesign the function  $G$  so that to constrain the state  $\hat{x}$ , at each instant time  $k \in \mathbb{N}$ , inside the desired set  $\mathcal{C}$ . However, differently from the previous continuous-time case, we do not modify the dynamics of (4.32) by adding a term to the map  $G$ . Instead, we build  $G_m$  by composition of the map  $G$  given in (4.32) with a (possibly multi-valued) time-varying map  $\psi_{k+1} : \mathbb{R}^{n_x} \rightrightarrows \mathbb{R}^{n_x}$ , namely

$$G_m(k, \cdot) := \psi_{k+1} \circ G(k, \cdot), \quad (4.33)$$

with the map  $\psi_{k+1}$  computed as

$$\psi_{k+1} = \psi_{k+1,\theta} \circ \dots \circ \psi_{k+1,1}, \quad (4.34)$$

for some  $\theta > 1$ , where each composition represents a numerical step. This implicitly requires that between any “discrete” times, we are allowed to carry out an algorithm involving several computations. In the context of sampled-data systems, this means that the digital controller is fast enough with respect to the sampling frequency.

Similarly to the continuous time case, we introduce then the map  $M_{k+1} : \mathbb{R}^{n_x} \rightarrow \mathbb{R}^{n_x}$  defined by

$$M_{k+1}(\hat{x}) := -\gamma_d P_{k+1}^{-1} \frac{dc}{dx}(\hat{x})^\top c(\hat{x}), \quad (4.35)$$

with  $P_k$  being a positive definite matrix given by a quadratic Lyapunov function for the nominal observer,  $c$  given by Lemma 4.2 and  $\gamma_d$  a strictly positive scalar to be chosen *small* enough, this time, contrarily to the continuous-time case in which the parameter  $\gamma_c$  has to be chosen large enough.

The redesign thus consists in correcting the state estimate  $G(k, \hat{x}_k, u_k, y_k)$  with the map  $M_{k+1}$  as long as the estimate is outside  $\mathcal{C}_\rho$ , namely the function  $\psi_{k+1,i}$  in (4.34) are selected as

$$\psi_{k+1,i}(\hat{x}) = \begin{cases} \hat{x} + M_{k+1}(\hat{x}) & \text{if } \hat{x} \in \mathbb{R}^{n_x} \setminus \mathcal{C}_\rho \\ \hat{x} & \text{otherwise} \end{cases} \quad (4.36)$$

for all  $i = 1 \dots \theta$  and all  $k \in \mathbb{N}$ . As it can be noted by the expression of  $M_{k+1}$ , the correction (4.36) uses the gradient of the convex map  $c$ , namely  $-dc/dx$ , to bring  $\hat{x}$  back to  $\hat{\mathcal{X}}$  along level sets of  $V_{k+1}$ . The recursive algorithm (4.34) stops when we cross  $\mathcal{C}_\rho$ . This strategy is depicted in Figure 4.1. Note that this could not be achieved in one iteration because  $\gamma_d$  needs to be sufficiently small to ensure that  $V_{k+1}$  decreases, thus justifying the  $\theta$  steps.



To sum up, one can show the existence of a  $\gamma_d^*$  small enough, such that, if  $\theta$  is large enough, namely if we apply enough multi-steps according to (4.35), then the modified observer (4.33), (4.34), (4.36) preserves the guaranteed convergence properties of Assumption 4.6 and furthermore  $\hat{x}$  lives in the set  $\mathcal{C}$  at all discrete time instants  $k \in \mathbb{N}$ . Note that one can modify the function  $\psi_{k+1,i}$  to be outer-semicontinuous in order to guarantee robustness with respect to numerical errors.

Finally, we remark that the previous discrete-time approach can be used also for continuous-time observers so that to obtain a hybrid redesign, namely an overall hybrid observer with flow and jump maps. Similarly, given a hybrid systems and a hybrid observers, both continuous-time (i.e. flow) and discrete-time (i.e. jump) redesign can be employed.

## 4.4 Uniting observers

When designing an observer for a dynamical system, we first of all want to ensure that the produced state estimate converges towards the plant state as time grows. We also desire to ensure the following key properties:

- (a) (*domain of attraction*) the convergence should be guaranteed irrespectively of the observer initialization;
- (b) (*convergence speed*) a certain convergence rate should be required for the observer to rapidly generate accurate estimates of the state;
- (c) (*model robustness*) the estimate needs to be accurate even in presence of model uncertainties;
- (d) (*sensitivity to noise*) the quality of the estimation should not be too sensitive to measurement noise.

It is very difficult, if not impossible<sup>3</sup>, to address all these requirements at the same time, in particular when dealing with nonlinear finite-dimensional systems. Hence, the observer design often results in a trade-off between some of the properties listed above. The objective of this section is therefore to propose a framework to combine two given observers in order to obtain a *uniting observer* inheriting the “good features” of each of them.

### 4.4.1 Problem statement

We consider nonlinear systems of the form

$$\dot{x} = f(x, u), \quad y = h(x, w), \quad (4.37)$$

where  $x \in \mathcal{X} \subseteq \mathbb{R}^{n_x}$  is the state,  $u \in \mathcal{U} \subseteq \mathbb{R}^{n_u}$  is a known input,  $y \in \mathbb{R}^{n_y}$  is the measured output, and  $w \in \mathcal{W} \subseteq \mathbb{R}^{n_w}$  represents an unknown measurement noise, with  $n_x, n_u, n_y, n_w \in \mathbb{Z}_{>0}$ . The sets  $\mathcal{X}, \mathcal{U}, \mathcal{W}$  are closed, the functions  $f, h$  are locally Lipschitz, and the signals corresponding to  $u$  and  $w$  in (4.37) are defined for all positive times, Lebesgue measurable and locally essentially bounded. We assume that we know two observers for system (4.37). One is referred to as the *local* observer, and the other one as the *global* observer. The local observer is the one we want to use when the estimation error is small, while the global observer guarantees that the estimation error becomes eventually sufficiently small for any possible initialization. The state variables

---

<sup>3</sup>Fundamental limitations arise, see [181] in the context of linear systems.

and the functions related to those observers will be indexed respectively with 0 (local) and 1 (global).

The dynamics of the local observer is described by

$$\dot{\zeta}_0 = \varphi_0(\zeta_0, u, y), \quad \hat{x}_0 = \vartheta_0(\zeta_0), \quad \hat{y}_0 = h(\hat{x}_0, 0), \quad (4.38)$$

where  $\zeta_0 \in \mathcal{Z}_0 \subseteq \mathbb{R}^{n_0}$  is the observer state,  $n_0 \in \mathbb{Z}_{>0}$  is the observer dimension satisfying<sup>4</sup>  $n_0 \geq n_x$ , and  $\hat{x}_0 \in \mathbb{R}^{n_x}$  is the estimate of  $x$ . The set  $\mathcal{Z}_0$  is closed and the functions  $\varphi_0, \vartheta_0$  are assumed to be locally Lipschitz. Loosely speaking, observer (4.38) is local and asymptotic in the sense that if the initial estimation error  $|x(0) - \hat{x}_0(0)|$  is small enough, then convergence of the estimation error in absence of measurement noise is guaranteed, namely  $\lim_{t \rightarrow \infty} |x(t) - \hat{x}(t)| = 0$ . This property is rigorously stated in Section 4.4.2. Although any observer which has global (or semiglobal) convergence properties satisfy this condition, local observers are of particular interest because they are often easy to design and they usually possess good robustness properties in presence of (small) measurement noise. A typical example is the extended Kalman filter (EKF) or its variations, see e.g., [38, 96, 117, 170].

The global observer for system (4.37) is of the form

$$\dot{\zeta}_1 = \varphi_1(\zeta_1, u, y), \quad \hat{x}_1 = \vartheta_1(\zeta_1), \quad \hat{y}_1 = h(\hat{x}_1, 0), \quad (4.39)$$

where  $\zeta_1 \in \mathcal{Z}_1 \subseteq \mathbb{R}^{n_1}$  is the observer state,  $n_1 \in \mathbb{Z}_{>0}$  is the observer dimension satisfying  $n_1 \geq n_x$  (similarly to (4.38)), and  $\hat{x}_1 \in \mathbb{R}^{n_x}$  is the estimate of  $x$ . The set  $\mathcal{Z}_1$  is closed and the functions  $\varphi_1, \vartheta_1$  are assumed to be locally Lipschitz. Examples of global observers can be found in [20, 115, 185, 221], [D25] for  $n_1 = n_x$  and in [12, 25, 74], [D14, D16, D65] for  $n_1 > n_x$ .

The main idea of this work is to combine observers (4.38) and (4.39) in order to benefit from the advantages of each of them. To address this problem, we aim at designing a hybrid observer of the general form below, based on (4.38) and (4.39),

$$\begin{aligned} \dot{\xi} &= F(\xi, u, y), & \xi &\in \mathcal{C}, \\ \xi^+ &= G(\xi, u, y), & \xi &\in \mathcal{D}, \\ \hat{x} &= H(\xi), \end{aligned} \quad (4.40)$$

where  $\xi \in \mathbb{R}^{n_\xi}$  is the observer state,  $n_\xi \in \mathbb{Z}_{>0}$ ,  $\mathcal{C} \subseteq \mathbb{R}^{n_\xi}$  and  $\mathcal{D} \subseteq \mathbb{R}^{n_\xi}$  are closed set, and  $\hat{x}$  is the estimate of  $x$ . As a result, system (4.37) and observer (4.40) lead to the overall hybrid system below

$$\begin{aligned} \left. \begin{aligned} \dot{x} &= f(x, u) \\ \dot{\xi} &= F(\xi, u, y) \end{aligned} \right\} & (x, \xi, u, w) \in \mathcal{X} \times \mathcal{C} \times \mathcal{U} \times \mathcal{W}, \\ \left. \begin{aligned} x^+ &= x \\ \xi^+ &= G(\xi, u, y) \end{aligned} \right\} & (x, \xi, u, w) \in \mathcal{X} \times \mathcal{D} \times \mathcal{U} \times \mathcal{W}, \\ \hat{x} &= H(\xi) \\ y &= h(x, w). \end{aligned} \quad (4.41)$$

Note that  $(u, w)$  needs to be defined on hybrid time domains in (4.41). With some abuse of notation, we consider  $u$  and  $w$  that are defined in such way that their values agree with  $(u(t), w(t))$  during flows, do not change during jumps, and their hybrid time domains correspond to that of  $(x, \xi)$ .

Our objective is to construct (4.40) to solve the problem stated next.

<sup>4</sup>We do not consider reduced order observers, namely observers with  $n_0 < n_x$ , though all the forthcoming results can be adapted to cover this case.

**Definition 4.1** (Uniting observer). *The observer (4.40) solves the uniting problem for system (4.37) if the following holds.*

- (a) (Completeness of solutions and finite number of jumps) Any (maximal) solution pair  $((x, \xi), (u, w))$  to (4.41) is complete and satisfies

$$\sup_t \text{dom}(x, \xi) = +\infty, \quad \sup_j \text{dom}(x, \xi) < \infty.$$

- (b) (Global convergence) There exists  $\gamma \in \mathcal{K}$  such that any solution pair  $((x, \xi), (u, w))$  to (4.41) satisfies

$$\limsup_{t+j \rightarrow \infty} |x(t, j) - \hat{x}(t, j)| \leq \gamma(\|w\|_\infty). \quad (4.42)$$

- (c) (Local behaviour) There exists a set  $\mathcal{B} \subseteq \mathcal{X} \times (\mathcal{C} \cup \mathcal{D})$  such that any solution pair  $((x, \xi), (u, w))$  to (4.41) with  $(x(0, 0), \xi(0, 0)) \in \mathcal{B}$ , has hybrid time domain  $[0, \infty) \times \{0\}$ , and  $\hat{x}(t, 0) = \hat{x}_0(t)$  for all  $t \in [0, \infty)$ , where  $\hat{x}_0$  is a solution to (4.37), (4.38).

Item (a) of Definition 4.1 means that the solutions of the hybrid observer (4.40) are complete, that no Zeno behaviour can occur and that switches stop in finite time. Item (b) of Definition 4.1 ensures that the estimation error has an asymptotic gain property with respect to the measurement noise with a global domain of attraction<sup>5</sup>. When there is no noise, i.e.  $w = 0$ , the global asymptotic convergence of the estimation error  $x - \hat{x}$  is ensured. Finally, item (c) guarantees that only the local observer (4.38) is used if observer (4.40) is initialized in such way that  $(x, \xi)$  is in the set  $\mathcal{B}$  at the initial time.

The rationale of the scheme we construct in the following is illustrated in Figure 4.2. We want to use the global observer (4.39) during transients, when the estimation error is large. Then, when  $|\hat{x}_1 - x|$  is small enough, we reset the variables of the local observer (4.38) according to the estimate  $\hat{x}_1$  provided by the global observer. Afterwards, we let the local observer run. This switching mechanism cannot be implemented in open loop, i.e. based on time only, for robustness reasons. We want a supervisor mechanism, which is able to switch between the two observers in order to cope with possible wrong initializations or large disturbances  $w$ , as depicted in Figure 4.3. This mechanism therefore needs to rely on  $|\hat{x}_0 - x|$  and  $|\hat{x}_1 - x|$ , but these quantities are not accessible since we do not know  $x$ . Inspired by [118, 160], we use instead estimates of these values based on the measured output  $y$  and the estimated outputs  $\hat{y}_0, \hat{y}_1$ , that is a norm-estimator. To this end, a certain number of assumptions will be established in the following.

#### 4.4.2 Assumptions

First of all, we suppose that the dynamics of system (4.37) and observers (4.38) and (4.39) are well posed in the sense that solutions are defined for all  $t \geq 0$ .

**Assumption 4.7.** *The following holds.*

1. For any initial condition  $(x(0), \zeta_0(0), \zeta_1(0)) \in \mathcal{X} \times \mathcal{Z}_0 \times \mathcal{Z}_1$ , and any input  $(u, w)$  taking values in  $\mathcal{U} \times \mathcal{W}$ , any corresponding solution pair to (4.37), (4.38), (4.39) is unique, defined on  $[0, \infty)$ , and  $(x(t), \zeta_0(t), \zeta_1(t)) \in \mathcal{X} \times \mathcal{Z}_0 \times \mathcal{Z}_1$  for all  $t \in [0, \infty)$ .
2. There exists a function  $\Theta : \mathbb{R}^{n_1} \rightarrow \mathbb{R}^{n_0}$  such that  $\Theta(\zeta_1) \in \mathcal{Z}_0$  and  $\vartheta_1(\zeta_1) = \vartheta_0(\Theta(\zeta_1))$  for all  $\zeta_1 \in \mathcal{Z}_1$ , where  $\vartheta_0, \vartheta_1$  come from (4.38) and (4.39), respectively.

---

<sup>5</sup>Global with respect to the domain of definition of system (4.41), that is  $\mathcal{X} \times (\mathcal{C} \cup \mathcal{D})$ .

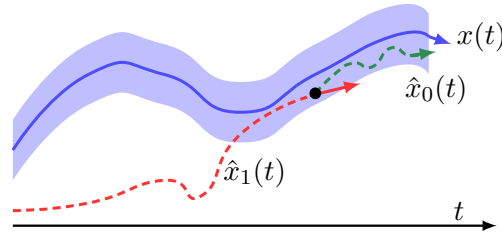

Figure 4.2: Strategy to unite local and global observers: when the estimate is far from the current state we use the global observer; then, when the estimate of the global observer is close enough to the actual trajectory of the plant, we activate the local observer initialized at the estimate given by the global observer. Blue line: trajectory  $x(t)$  of system (4.37). Dotted red line: trajectory  $\hat{x}_1(t)$  of global observer (4.39). Dotted green line: trajectory  $\hat{x}_0(t)$  of local observer (4.38).

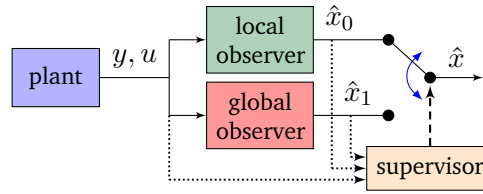

Figure 4.3: Hybrid scheme to unite local observer (4.38) and global observer (4.39).

Item (i) of Assumption 4.7 states that the trajectories of the system (4.37) and of the observers (4.38), (4.39) are well defined and lie in the sets  $\mathcal{X}$ ,  $\mathcal{Z}_0$ ,  $\mathcal{Z}_1$  for all times. Function  $\Theta$  in item (ii) of Assumption 4.7 is needed to map the global observer variable  $\zeta_1$  to the local observer variable  $\zeta_0$ , which is essential when the local observer is activated. In particular, when this occurs, we will take  $\zeta_0^+ = \Theta(\zeta_1)$ . Hence, since  $\Theta(\zeta_1) \in \mathcal{Z}_0$  for any  $\zeta_1 \in \mathcal{Z}_1$ , we are sure that the reset value of  $\zeta_0$  lies in  $\mathcal{Z}_0$ , as required. Moreover, item (ii) ensures also that  $\hat{x}_0^+ = \hat{x}_1$ . When the dimensions of the observers coincide and their dynamics are expressed in the same coordinates,  $\Theta$  is simply the identity map.

The next assumption formalizes the properties of local observer (4.38).

**Assumption 4.8** (Local observer). *There exist a continuous function  $V_0 : \mathcal{X} \times \mathcal{Z}_0 \rightarrow \mathbb{R}_{\geq 0}$ ,  $\gamma_0 \in \mathcal{K}$ , and  $\varepsilon'_0 > \varepsilon_0 > 0$ , such that the following holds.*

1. (Local convergence) *Any solution pair  $((x, \zeta_0), (u, w))$  to (4.37), (4.38), with initial condition such that  $V_0(x(0), \zeta_0(0)) \leq \varepsilon'_0$ , satisfies  $\limsup_{t \rightarrow \infty} |x(t) - \hat{x}_0(t)| \leq \gamma_0(\|w\|_\infty)$ .*
2. (Invariance property) *Any solution pair  $((x, \zeta_0), (u, w))$  to (4.37), (4.38), with initial condition such that  $V_0(x(0), \zeta_0(0)) \leq \varepsilon_0$ , satisfies  $V_0(x(t), \zeta_0(t)) \leq \varepsilon_0$  for all  $t \in [0, \infty)$ .*

The function  $V_0$  is used to characterize the domain of attraction of local observer (4.38), which contains the set  $\{(x, \zeta_0) : V_0(x, \zeta_0) \leq \varepsilon'_0\}$ , see item (i) of Assumption 4.8. On the other hand, when the initial estimation error satisfies  $V_0(x(0), \zeta_0(0)) \leq \varepsilon'_0$ , then it has an asymptotic gain property with respect to the measurement noise  $w$ , and converges asymptotically to zero when  $w(t) = 0$  for all  $t \geq 0$ , since  $\gamma_0(0) = 0$ , according to item (i) of Assumption 4.8. Function  $V_0$  typically corresponds to the Lyapunov function that is used to prove the convergence of the local observer and satisfies  $\underline{\alpha}_0(|x - \hat{x}_0|) \leq V(x, \zeta_0)$  for some  $\underline{\alpha}_0 \in \mathcal{K}$ . According to this interpretation,

$\{(x, \zeta_0) : V_0(x, \zeta_0) \leq \varepsilon_0\}$  can be viewed as an invariant Lyapunov level set of size  $\varepsilon_0$ , see item (ii) of Assumption 4.8. In general the values of  $\varepsilon'_0, \varepsilon_0$  depend on the maximum allowed magnitude of the measurement noise, namely on  $\sup_{w \in \mathcal{W}} |w|$ .

In the next assumption we suppose that function  $V_0$ , evaluated along the solutions to (4.37), (4.38), can be overestimated by a dynamical system (a norm estimator). The latter will be essential to detect when to activate the local observer.

**Assumption 4.9** (Estimator of  $V_0$ ). *There exist a continuous function  $\rho_0 : \mathbb{R}^{n_y} \times \mathbb{R}^{n_y} \rightarrow \mathbb{R}_{\geq 0}$  satisfying  $\rho_0(y, y) = 0$  for any  $y \in \mathbb{R}^{n_y}$ ,  $\beta_0 \in \mathcal{KL}$ ,  $a_0, b_0, c_0 > 0$  and  $v_0 \geq 0$ , such that, under Assumption 4.8, the following holds.*

1. Any solution pair  $((x, \zeta_0), (u, w))$  to (4.37), (4.38), satisfies

$$V_0(x(t), \zeta_0(t)) \leq a_0 z_0(t) + \beta_0(V_0(x(0), \zeta_0(0)) + z_0(0), t) + v_0$$

for all  $t \geq 0$ , where  $z_0$  is the solution starting from  $z_0(0) \in \mathbb{R}_{\geq 0}$  to

$$\dot{z}_0 = -b_0 z_0 + \rho_0(y, \hat{y}_0). \quad (4.43)$$

2. The function  $\rho_0$  satisfies

$$\sup \{\rho_0(y, \hat{y}_0) : (x, \zeta_0) \in \mathcal{X} \times \mathcal{Z}_0, V_0(x, \zeta_0) \leq \varepsilon_0, w \in \mathcal{W}\} \leq b_0 c_0,$$

where  $y = h(x, w)$  and  $\hat{y}_0 = h(\vartheta_0(\zeta_0), 0)$ .

3.  $\varepsilon_0 \leq a_0 c_0 < \varepsilon'_0 - v_0$ .

Assumption 4.9 states that function  $V_0$  can be overestimated via the dynamical system (4.43), which is called in the following as a *norm estimator*, to be consistent with the terminology coined in [118]. In particular, in view of item (i) of Assumption 4.9, and the fact that  $\beta_0 \in \mathcal{KL}$ , the state  $z_0$  asymptotically provides an upper bound of  $V_0$ , up to the constant  $v_0$ . The norm estimator (4.43) can thus be used to detect whether the state of the local observer (4.38) is in the domain of attraction  $V_0(x, \zeta_0) \leq \varepsilon'_0$ , established by Assumption 4.8. For this, note that if  $(x(t), \zeta_0(t))$  satisfies  $V_0(x(t), \zeta_0(t)) \leq \varepsilon_0$  for all  $t \geq 0$ , then, in view of (4.43) and item (ii) of Assumption 4.9, we obtain  $\lim_{t \rightarrow \infty} z_0(t) \leq c_0$ , which implies, in view of items (i) and (iii) of Assumption 4.9 and the properties of  $\beta_0$ , that  $\limsup_{t \rightarrow \infty} V_0(x(t), \zeta_0(t)) \leq a_0 c_0 + v_0 < \varepsilon'_0$ . In other words, any solution  $(x, \zeta_0)$  satisfying  $z_0 \leq c_0$  for a large enough amount of time ensures that the local observer is asymptotically converging to the plant state, up to the perturbing term due to  $w$ , see item (i) of Assumption 4.8.

Item (i) of Assumption 4.9 is always satisfied when the system is uniformly observable (see, e.g., [84]), namely when a global asymptotic observer exists, as shown in [36]. If there exist  $\varrho_0, \psi_0 \in \mathcal{K}$  such that the function  $V_0$  satisfies, along any solution to (4.37), (4.38), the following differential inequality

$$\dot{V}_0 \leq -b_0 V_0 + \varrho_0(|y - \hat{y}_0|) + \psi_0(|w|), \quad (4.44)$$

then, item (i) of Assumption 4.9 is verified by selecting any  $\rho_0$  such that  $\rho_0(s_1, s_2) \geq \varrho_0(|s_1 - s_2|)$  for all  $s_1, s_2 \in \mathbb{R}^{n_y}$  and  $v_0 = b_0^{-1} \sup_{w \in \mathcal{W}} \psi_0(|w|)$ . To see this, it suffices to apply the comparison principle to the following differential inequality obtained by subtracting (4.43) to (4.44)

$$\begin{aligned} \dot{V}_0 - \dot{z}_0 &\leq -b_0(V_0 - z_0) + \varrho_0(|y - \hat{y}_0|) - \rho_0(y, \hat{y}_0) + \psi_0(|w|) \\ &\leq -b_0(V_0 - z_0) + b_0 v_0. \end{aligned}$$

Item (ii) of Assumption 4.9 is then satisfied by properly selecting the constant  $a_0, c_0$ . Note that the constant  $v_0 \geq 0$  is a bias introduced by the measurement noise. When the noise is not present, we have in general  $v_0 = 0$ ; however, if it is too large, item (iii) of Assumption 4.9 may not be satisfied. This means that our results are, in general, valid for “small” noise. Depending on the design of the observer, the function  $\varrho_0$  in (4.44) may be a degree of freedom or imposed by the structure of  $V_0$ .

In the next assumption, we define the properties of the global observer (4.39).

**Assumption 4.10** (Global observer). *There exist a continuous function  $V_1 : \mathcal{X} \times \mathcal{Z}_1 \rightarrow \mathbb{R}_{\geq 0}$  and  $\varepsilon_1 > 0$  such that, any solution pair  $((x, \zeta_1), (u, w))$  to (4.37), (4.39), satisfies*

$$\limsup_{t \rightarrow \infty} V_1(x(t), \zeta_1(t)) < \varepsilon_1.$$

The function  $V_1$  is used to characterize the asymptotic behaviour of the global observer. Typically, the function  $V_1$  is the Lyapunov function constructed to show the convergence of the global observer and satisfies  $\underline{\alpha}_1(|x - \hat{x}_1|) \leq V_1(x, \zeta_1)$  for some  $\underline{\alpha}_1 \in \mathcal{K}_\infty$ . In this case,  $\varepsilon_1$  characterizes the ultimate bound of the estimation error of (4.39) and depends, in general on the magnitude of the measurement noise, namely on  $\sup_{w \in W} |w|$ . When  $w = 0$ , the value of  $\varepsilon_1$  depends on the properties of the observer (4.39) and may be selected arbitrarily small if the observer is asymptotically convergent. The next assumption states that function  $V_1$  can be overestimated by a dynamical system.

**Assumption 4.11** (Estimator of  $V_1$ ). *There exist a continuous function  $\rho_1 : \mathbb{R}^{n_y} \times \mathbb{R}^{n_y} \rightarrow \mathbb{R}_{\geq 0}$ ,  $a_1, b_1, c_1, \varepsilon'_1 > 0$ , and  $v_1 \geq 0$ , such that, under Assumption 4.10, the following holds.*

1. *Any solution pair  $((x, \zeta_1), (u, w))$  to (4.37), (4.39), satisfies*

$$V_1(x(t), \zeta_1(t)) \leq a_1 z_1(t) + \beta_1(V_1(x(0), \zeta_1(0)) + z_1(0), t) + v_1$$

*for all  $t \in [0, \infty)$ , where  $z_1$  is the solution starting from  $z_1(0) \in \mathbb{R}_{\geq 0}$  to*

$$\dot{z}_1 = -b_1 z_1 + \rho_1(y, \hat{y}_1). \quad (4.45)$$

2. *The function  $\rho_1$  satisfies*

$$\sup\{\rho_1(y, \hat{y}_1) : (x, \zeta_1) \in \mathcal{X} \times \mathcal{Z}_1, V_1(x, \zeta_1) \leq \varepsilon_1, w \in \mathcal{W}\} \leq b_1 c_1,$$

*where  $y = h(x, w)$  and  $\hat{y}_1 = h(\vartheta_1(\zeta_1), 0)$ .*

3.  $\varepsilon_1 \leq a_1 c_1 < \varepsilon'_1 - v_1$ .

Finally, for the approach to work, we need the ultimate bound of the estimation error provided by global observer (4.39) to be included in the basin of attraction of local observer (4.38). This condition is referred to as a switching condition.

**Assumption 4.12** (Switching condition). *For any  $(x, \zeta_1) \in \mathcal{X} \times \mathcal{Z}_1$  satisfying  $V_1(x, \zeta_1) \leq \varepsilon'_1$ , then  $V_0(x, \Theta(\zeta_1)) \leq \varepsilon_0$ , where  $\Theta$  is defined in the Standing Assumption,  $V_0, \varepsilon_0$  in Assumption 4.8,  $V_1$  in Assumption 4.10 and  $\varepsilon'_1$  in Assumption 4.11.*

Assumption 4.12 requires that  $\{(x, \zeta_1) : V_1(x, \zeta_1) \leq \varepsilon'_1\}$  is included in  $\{(x, \zeta_0) : V_0(x, \zeta_0) \leq \varepsilon_0\}$ , when  $\zeta_0 = \Theta(\zeta_1)$ , as depicted in Figure 4.4. Recall that, in view of Assumption 4.10, solutions to (4.37), (4.39) enters in the set  $\{(x, \zeta_1) : V_1(x, \zeta_1) \leq \varepsilon'_1\}$ . Moreover, this can be detected via the norm estimator (4.45), see Assumption 4.11. As a consequence, Assumption 4.12 guarantees that, after a sufficient long amount of time, we can reset  $\zeta_0^+ = \Theta(\zeta_1)$ , with  $\Theta$  defined in the Standing Assumption, in order to guarantee asymptotic convergence of the local observer (4.38), see item (i) of Assumption 4.8.

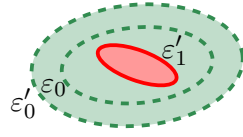

Figure 4.4: Switching condition of Assumption 4.12. Dashed green line: level sets of  $V_0(x, \zeta_0)$ . Red line: level sets of  $V_1(x, \zeta_1)$ .

### 4.4.3 Main result

The overall hybrid observer consists of six components: local observer (4.38), global observer (4.39), norm estimators (4.43), (4.45), a temporal regularization  $\tau$ , which may be added to prevent undesired consecutive jumps, and a logic variable  $q$  taking values in  $\{0, 1\}$  defining which state estimate,  $\hat{x}_0$  or  $\hat{x}_1$ , we need to use. In particular, we design the following hybrid observer

$$\left. \begin{aligned} \dot{\zeta}_0 &= (1-q)\varphi_0(\zeta_0, u, y) \\ \dot{\zeta}_1 &= \varphi_1(\zeta_1, u, y) \\ \dot{z}_0 &= (1-q)(-b_0 z_0 + \rho_0(y, \hat{y}_0)) \\ \dot{z}_1 &= -b_1 z_1 + \rho_1(y, \hat{y}_1) \\ \dot{\tau} &= q \\ \dot{q} &= 0 \end{aligned} \right\} \xi \in \mathcal{C} \quad (4.46a)$$

$$\left. \begin{aligned} \zeta_0^+ &= q\Theta(\zeta_1) + (1-q)\zeta_0 \\ \zeta_1^+ &= \zeta_1 \\ z_0^+ &= 0 \\ z_1^+ &= z_1 \\ \tau^+ &= 0 \\ q^+ &= 1-q \end{aligned} \right\} \xi \in \mathcal{D} \quad (4.46b)$$

$$\hat{x} = (1-q)\hat{x}_0 + q\hat{x}_1, \quad (4.46c)$$

in which we use the definitions of  $\hat{x}_0$ ,  $\hat{x}_1$ ,  $\hat{y}_0$  and  $\hat{y}_1$ , given in (4.38), (4.39). The overall state  $\xi \in \mathcal{O} \subseteq \mathbb{R}^{n_\xi}$ , with  $\mathcal{O} := \mathcal{Z}_0 \times \mathcal{Z}_1 \times \mathbb{R}^4$  and  $n_\xi := n_0 + n_1 + 4$ , is therefore defined as

$$\xi := (\zeta_0, \zeta_1, z_0, z_1, \tau, q) \in \mathbb{R}^{n_\xi} = \mathbb{R}^{n_0} \times \mathbb{R}^{n_1} \times \mathbb{R}^4. \quad (4.47a)$$

The sets  $\mathcal{C} \cup \mathcal{D} \subseteq \mathcal{O}$  are defined as  $\mathcal{C} := \mathcal{C}_0 \cup \mathcal{C}_1$  and  $\mathcal{D} := \mathcal{D}_0 \cup \mathcal{D}_1$ , with

$$\begin{aligned} \mathcal{C}_0 &:= \{\xi \in \mathcal{O} : z_0 \in [0, c'_0], z_1 \in [0, \infty), \tau \in [0, \infty), q = 0\}, \\ \mathcal{C}_1 &:= \{\xi \in \mathcal{O} : z_0 = 0, (z_1 \in [c'_1, \infty) \text{ or } \tau \in [0, T]), q = 1\}, \\ \mathcal{D}_0 &:= \{\xi \in \mathcal{O} : z_0 \in [c'_0, \infty), z_1 \in [0, \infty), \tau \in [0, \infty), q = 0\}, \\ \mathcal{D}_1 &:= \{\xi \in \mathcal{O} : z_0 = 0, z_1 \in [0, c'_1], \tau \in [T, \infty), q = 1\}, \end{aligned} \quad (4.47b)$$

where  $c'_0, c'_1 > 0$  are design parameters to be properly chosen. According to the definition of the set  $\mathcal{C}$ , the parameter  $T$  is used to enforce a minimum amount of time  $T$  of flow after a jump when it is taken strictly positive, when flowing in the set  $\mathcal{C}_1$  defined in (4.47b). Note that according to

the definition of (4.46), we can use the compact notation (4.40) by defining  $F, G, H$  as

$$F(\xi, u, y) := \left( (1-q)\varphi_0(\zeta_0, u, y), \varphi_1(\zeta_1, u, y), \right. \quad (4.47c)$$

$$\left. (1-q)(-b_0z_0 + \rho_0(y, h(\vartheta_0(\zeta_0), 0))), \right. \\ \left. -b_1z_1 + \rho_1(y, h(\vartheta_1(\zeta_1), 0)), q, 0 \right),$$

$$G(\xi, u, y) := (q\Theta(\zeta_1) + (1-q)\zeta_0, \zeta_1, 0, z_1, 0, 1-q), \quad (4.47d)$$

$$H(\xi) := (1-q)\vartheta_0(\zeta_0) + q\vartheta_1(\zeta_1). \quad (4.47e)$$

The proposed hybrid observer (4.46) has two different operating modes. When  $q = 1$ , we use global observer (4.39). Thanks to the norm estimator (4.45), we can detect when the estimate  $\hat{x}_1$  is close enough to the true value of the estimated state  $x$ . The temporal regularization  $\tau$  imposes to use global observer for at least a  $T$  units of (continuous) time. This allows to avoid unnecessary multiple consecutive jumps in the scheme (4.46) and to always enforce a flow after a jump when  $T > 0$ . When  $q = 0$ , the estimate is given by the local observer. A wrong behaviour of the local observer, namely when its estimate is not converging to the trajectory of the plant, is detected when the state of norm estimator  $z_0$  becomes too large. In this case, a jump is imposed and we change the operating mode. Note that, when  $q = 0$ , global observer (4.39) is still used as a “safeguard”. In particular, since the state of global observer (4.39) is never reset, after a time large enough, we know that its estimate always satisfies the bounds in item (i) of Assumption 4.11. As a result, unwanted behaviours, such as infinitely many switches in absence of measurement noise, are avoided.

**Theorem 4.4.** *Suppose Assumptions 4.8 to 4.12 hold. Let  $T \in [0, \infty)$ ,  $c'_0 \in (c_0, c''_0)$  with  $c''_0 = \frac{\varepsilon'_0 - v_0}{a_0}$ , and  $c'_1 \in (c_1, c''_1)$ , with  $c''_1 = \frac{\varepsilon'_1 - v_1}{a_1}$ , where  $a_0, a_1, c_0, c_1, \varepsilon'_0, \varepsilon'_1, v_0, v_1$  are given in Assumptions 4.7-4.12. Then the hybrid observer (4.40), with  $\xi, F, G, H, \mathcal{C}, \mathcal{D}$  chosen as in (4.47), solves the uniting problem with  $\gamma = \gamma_0$  and*

$$\mathcal{B} := \{(x, \xi) \in \mathcal{X} \times \mathcal{O} : V_0(x, \zeta_0) \leq \varepsilon_0, z_0 \in [0, c_0], z_1 \in [0, \infty), \tau \in [0, \infty), q = 0\},$$

where  $\gamma_0, V_0$  are given by Assumption 4.8.

Note that the choice of  $c'_0, c'_1$  in the statement of the theorem is always feasible since  $a_0c_0 < \varepsilon'_0 - v_0$  in view of item (iii) of Assumption 4.9, and  $a_1c_1 < \varepsilon'_1 - v_1$  in view of item (iii) of Assumption 4.11.

The conditions of Theorem 4.4 typically require the noise  $w$  to be small, as already mentioned. When a large measurement noise is considered, some of the previous assumptions may no longer hold. However, as long as the behaviour of the global observer is well defined, and finite escape time of the local observer do not occur, the scheme proposed in (4.47) guarantees completeness of solutions. It may happen, however, that infinitely many switches occur as the local observer fails to converge and the global observer moves persistently back and forth from the set  $\{(x, \zeta_1) : V_1(x, \zeta_1) \leq \varepsilon'_1\}$ .

## 4.5 Multi-observers approach

In the previous section we have shown how to combine two given observer in order to try to take advantage of both good properties. Here, we propose a generalization of this approach by extending the idea of using multiple observers in parallel. In particular, we present a flexible



and general observer design methodology based on supervisory multi-observer ideas that can be used to address various trade-offs between robustness to modeling errors and measurement noise, and convergence speed. The starting point that we propose is the knowledge of a nominal observer, which ensures that the associated state estimation error system satisfies an ISS property with respect to measurement noise and disturbances. Then, we construct a multi-observer, composed of the nominal observer and additional dynamical systems, all together called *modes*, that have the same structure as the nominal observer, but different gains. The number of modes and the associated gains can be freely assigned (no specific stability/convergence property is required). Because the gains are different, each mode exhibits different properties in terms of speed of convergence and robustness to measurement noise. We run all modes in parallel and we evaluate their estimation performance in terms of a quadratic cost using monitoring variables. These monitoring variables extend the idea developed in the context of uniting two observers. In practice, we use a norm estimator which is however driven not only by the estimation output error but also by the energy correlated to correction gain. Based on these running costs (i.e., monitoring variables), we design then a switching rule that selects, at any time instant, the mode which is providing the best performance. When a new mode is selected, the other ones may reset or not their current state estimate (and their monitoring variable) to it.

#### 4.5.1 Problem statement

We consider the plant model

$$\begin{aligned}\dot{x} &= f_p(x, u, v) \\ y &= h(x, w),\end{aligned}\tag{4.48}$$

where  $x \in \mathbb{R}^{n_x}$  is the state to be estimated,  $u \in \mathbb{R}^{n_u}$  is the measured input,  $y \in \mathbb{R}^{n_y}$  is the measured output,  $v \in \mathbb{R}^{n_v}$  is an unknown disturbance input and  $w \in \mathbb{R}^{n_w}$  is an unknown measurement noise, with  $n_x, n_y \in \mathbb{Z}_{>0}$  and  $n_u, n_v, n_w \in \mathbb{Z}_{\geq 0}$ . The input signal  $u : \mathbb{R}_{\geq 0} \rightarrow \mathbb{R}^{n_u}$ , the unknown disturbance input  $v : \mathbb{R}_{\geq 0} \rightarrow \mathbb{R}^{n_v}$  and the measurement noise  $w : \mathbb{R}_{\geq 0} \rightarrow \mathbb{R}^{n_w}$  are such that  $u \in \mathcal{L}\mathcal{U}$ ,  $v \in \mathcal{L}\mathcal{V}$  and  $w \in \mathcal{L}\mathcal{W}$  for closed sets  $\mathcal{U} \subseteq \mathbb{R}^{n_u}$ ,  $\mathcal{V} \subseteq \mathbb{R}^{n_v}$  and  $\mathcal{W} \subseteq \mathbb{R}^{n_w}$ . We consider a nominal observer for system (4.48) of the form

$$\begin{aligned}\dot{\hat{x}}_1 &= f_o(\hat{x}_1, u, L_1(y - \hat{y}_1)) \\ \hat{y}_1 &= h(\hat{x}_1, 0),\end{aligned}\tag{4.49}$$

where  $\hat{x}_1 \in \mathbb{R}^{n_x}$  is the state estimate,  $\hat{y}_1 \in \mathbb{R}^{n_y}$  is the output estimate and  $L_1 \in \mathbb{R}^{n_{L_1} \times n_y}$  is the observer output injection gain with  $n_{L_1} \in \mathbb{Z}_{>0}$ . We define the estimation error as  $e_1 := x - \hat{x}_1 \in \mathbb{R}^{n_x}$  and introduce a *perturbed* version of the error dynamics, following from (4.48) and (4.49), as

$$\begin{aligned}\dot{e}_1 &= f_p(x, u, v) - f_o(\hat{x}_1, u, L_1(y - \hat{y}_1)) + d \\ &=: \tilde{f}(e_1, x, u, v, w, d)\end{aligned}\tag{4.50}$$

where  $d \in \mathbb{R}^{n_{L_1}}$  represents an additive perturbation on the output injection term  $L_1(y - \hat{y}_1)$ . Similarly to Section 4.2, the following two assumptions are made.

**Assumption 4.13.** *There exist  $\underline{\alpha}, \bar{\alpha}, \psi_1, \psi_2 \in \mathcal{K}_\infty$ ,  $\alpha \in \mathbb{R}_{>0}$ ,  $\gamma \in \mathbb{R}_{\geq 0}$  and  $V : \mathbb{R}^{n_x} \rightarrow \mathbb{R}_{\geq 0}$  continuously differentiable, such that the following hold*

$$\begin{aligned}\underline{\alpha}(|e_1|) &\leq V(e_1) \leq \bar{\alpha}(|e_1|) \\ \langle \nabla V(e_1), \tilde{f}(e_1, x, u, v, w, d) \rangle &\leq -\alpha V(e_1) + \psi_1(|v|) + \psi_2(|w|) + \gamma|d|^2,\end{aligned}$$

for all  $x \in \mathbb{R}^{n_x}$ ,  $e_1 \in \mathbb{R}^{n_x}$ ,  $d \in \mathbb{R}^{n_{L_1}}$ ,  $u \in \mathcal{U}$ ,  $v \in \mathcal{V}$ ,  $w \in \mathcal{W}$ .

**Assumption 4.14.** *There exist  $\delta_1, \delta_2 \in \mathbb{R}_{>0}$  such that for all  $x, x' \in \mathbb{R}^{n_x}$ ,  $w, w' \in \mathcal{W}$ ,*

$$|h(x, w) - h(x', w')|^2 \leq \delta_1 V(x - x') + \delta_2 |w - w'|^2,$$

where  $V$  comes from Assumption 4.13.

As detailed in Section 4.2, Assumption 4.13 implies that the estimation error is II, namely the existence of  $\beta \in \mathcal{KL}$  and  $\rho \in \mathcal{K}_\infty$  such that, any solution  $(x, e_1)$  to systems (4.48) and (4.50) verifies

$$|e_1(t)| \leq \beta(|e_1(0)|, t) + \rho(|v|_{[0,t]} + |w|_{[0,t]} + |d|_{[0,t]}).$$

for all  $t \in \text{dom}(x, e_1)$ , and for any  $u \in \mathcal{L}_U$ ,  $v \in \mathcal{L}_V$ ,  $w \in \mathcal{L}_W$  and  $d \in \mathcal{L}_{\mathbb{R}^{n_{L_1}}}$ . The previous bound provides a desirable robust stability property of the estimation error associated to observer (4.49).

## 4.5.2 Hybrid estimation scheme

The hybrid estimation scheme we propose consists of the following elements, see Fig. 4.5:

- *nominal observer* given in (4.49);
- $N$  additional dynamical systems of the form (4.49) but with a different output injection gain, where  $N \in \mathbb{Z}_{>0}$ . Each of these systems, as well as the nominal observer, is called *mode* for the sake of convenience;
- $N+1$  *monitoring variables* used to evaluate the performance of each mode of the multi-observer;
- *a selection criterion*, that switches between the state estimates produced by the different modes exploiting the performance knowledge given by the monitoring variables;
- *a reset rule*, that defines how the estimation scheme may be updated when the selected mode switches.

The extra  $N \in \mathbb{Z}_{>0}$  additional mode takes the form

$$\begin{aligned} \dot{\hat{x}}_k &= f_o(\hat{x}_k, u, L_k(y - \hat{y}_k)) \\ \hat{y}_k &= h(\hat{x}_k, 0), \end{aligned} \tag{4.51}$$

where  $\hat{x}_k \in \mathbb{R}^{n_x}$  is the  $k^{\text{th}}$  mode state estimate,  $\hat{y}_k \in \mathbb{R}^{n_y}$  is the  $k^{\text{th}}$  mode output and  $L_k \in \mathbb{R}^{n_{L_1} \times n_y}$  is its gain. For these  $N$  observers (4.51) we don't require/assume any ISS-property (i.e. they could be potentially unstable). For simplicity we consider constant gains, but selecting time-varying gains  $L_k(t)$  would be a possible choice, provided the gains are uniformly bounded.

Given the  $N + 1$  modes, our goal is now to find a way to select the “best” between them, namely the one providing a better estimate, possibly improving the estimation given by the nominal observer (4.49). Ideally, the criterion used to evaluate the performance of each mode would depend on the estimation errors  $e_k = x - \hat{x}_k$ , with  $k \in \{1, \dots, N + 1\}$ . However, since the state  $x$  is unknown,  $e_k$  is unknown and any performance criterion involving  $e_k$  would not be implementable. As a consequence, we rely on the knowledge of the output  $y$  and the estimated outputs  $\hat{y}_k$  for  $k \in \{1, \dots, N + 1\}$ . In particular, inspired by [214], in order to evaluate the

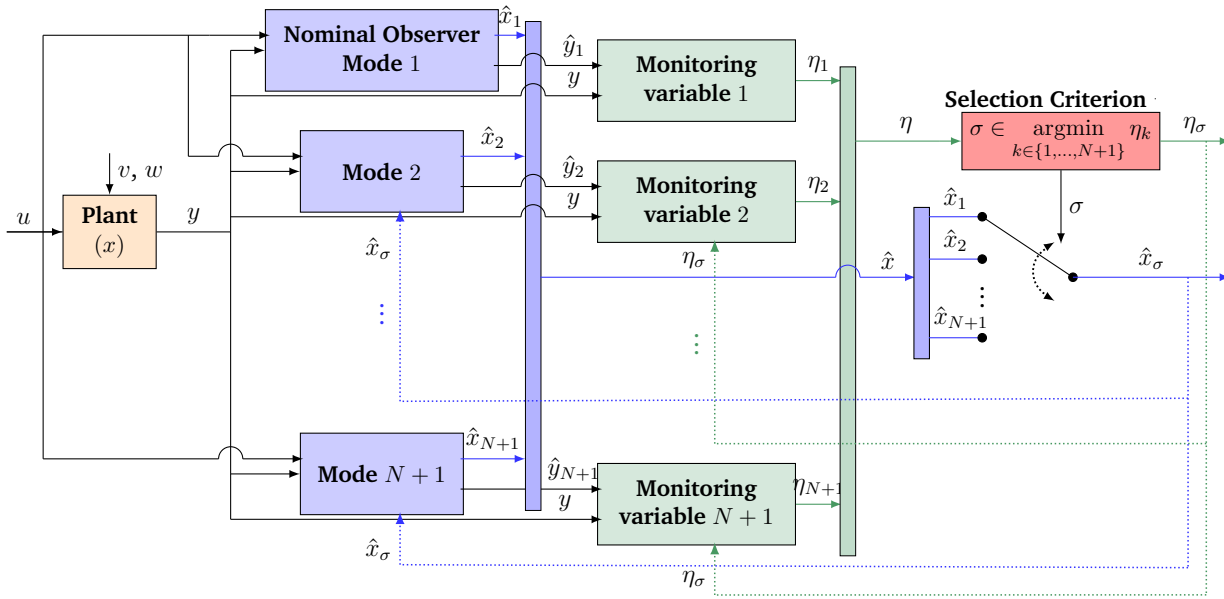

Figure 4.5: Block diagram representing the system architecture with  $\eta := (\eta_1, \dots, \eta_{N+1})$ ,  $\hat{x} := (\hat{x}_1, \dots, \hat{x}_{N+1})$ .

performance of each mode, we introduce the  $N + 1$  monitoring variables  $\eta_k \in \mathbb{R}_{\geq 0}$  for any  $k \in \{1, \dots, N + 1\}$ , with dynamics given by

$$\begin{aligned} \dot{\eta}_k &= -\nu\eta_k + (y - \hat{y}_k)^\top (\Lambda_1 + L_k^\top \Lambda_2 L_k) (y - \hat{y}_k) \\ &=: g(\eta_k, L_k, y, \hat{y}_k), \end{aligned} \quad (4.52)$$

with  $\Lambda_1, \Lambda_2$  being semi-positive definite with at least one of them positive definite and  $\nu \in (0, \alpha]$  a design parameter, where  $\alpha$  comes from Assumption 4.13. The term  $(y - \hat{y}_k)^\top \Lambda_1 (y - \hat{y}_k)$  in (4.52) is related to the output estimation error, while  $(y - \hat{y}_k)^\top L_k^\top \Lambda_2 L_k (y - \hat{y}_k)$  takes into account the correction effort of the observer, also called *latency* in [214]. Note that the monitoring variable  $\eta_k$  in (4.52) for all  $k \in \{1, \dots, N + 1\}$  is implementable since we have access to the output  $y$  and all the estimated outputs  $\hat{y}_k$  at all time instants. The monitoring variables  $\eta_k$ , with  $k \in \{1, \dots, N + 1\}$ , provide evaluations of the performance of all the modes of the multi-observer. Indeed, by integrating (4.52) between time 0 and  $t \in \mathbb{R}_{\geq 0}$ , we obtain for any  $k \in \{1, \dots, N + 1\}$

$$\eta_k(t) = e^{-\nu t} \eta_k(0) + \int_0^t e^{-\nu(t-\tau)} \left( (y(\tau) - \hat{y}_k(\tau))^\top (\Lambda_1 + L_k^\top \Lambda_2 L_k) (y(\tau) - \hat{y}_k(\tau)) \right) d\tau \quad (4.53)$$

for any initial condition  $\eta_k(0) \in \mathbb{R}_{\geq 0}$ , for any  $y, \hat{y}_k \in \mathcal{L}_{\mathbb{R}^{n_y}}$ , and any  $t \geq 0$ . The previous equation defines a finite-horizon discounted cost that depends on the output estimation error.

Based on the monitoring variables  $\eta_k$ , with  $k \in \{1, \dots, N + 1\}$ , we define a criterion to select the state estimate to look at. We use a signal  $\sigma : \mathbb{R}_{\geq 0} \rightarrow \{1, \dots, N + 1\}$  for this purpose, and we denote the selected state estimate mode  $\hat{x}_\sigma$  and the associated monitoring variable  $\eta_\sigma$ . The criterion consists in selecting the mode with the minimal monitoring variable, which implies minimizing the cost (4.53) over the modes  $k \in \{1, \dots, N + 1\}$ . When several modes produce the same minimum monitoring variable at a given time, we select the mode, between the ones with the minimum monitoring variables, with the smaller derivative of  $\eta_k$  (which is given by  $g(\eta_k, L_k, y, \hat{y}_k)$  from (4.52)). Moreover, if two or more modes have the same minimum

monitoring variable and the same minimum derivative of the monitoring variable, then the proposed technique selects randomly one of them. As a consequence, we switch the selected mode only when there exists  $k \in \{1, \dots, N + 1\} \setminus \{\sigma\}$  such that  $\eta_k \leq \eta_\sigma$ . In that way, at the initial time  $t_0 = 0$ , we take

$$\sigma(0) \in \underset{k \in \Pi}{\operatorname{argmin}} (g(\eta_k(0), L_k, y(0), \hat{y}_k(0)))$$

where  $\eta := \{\eta_1, \dots, \eta_{N+1}\}$  and

$$\Pi(\eta) := \underset{k \in \{1, \dots, N+1\} \setminus \{\sigma\}}{\operatorname{argmin}} \eta_k$$

for all  $\eta \in \mathbb{R}_{\geq 0}^{N+1}$ . Then,  $\sigma$  is kept constant, i.e.,  $\dot{\sigma}(t) = 0$  for all  $t \in (0, t_1)$ , with

$$t_1 := \inf\{t \geq 0 : \exists k \in \{1, \dots, N + 1\} \setminus \{\sigma(t)\} \text{ such that } \eta_k(t) \leq \eta_{\sigma(t)}(t)\}.$$

At time  $t_1$ , we switch the selected mode according to

$$\sigma(t_1^+) \in \underset{k \in \Pi}{\operatorname{argmin}} (g(\eta_k(t_1), L_k, y(t_1), \hat{y}_k(t_1))).$$

We repeat these steps iteratively and we denote with  $t_i \in \mathbb{R}_{\geq 0}$ ,  $i \in \mathbb{Z}_{>0}$  the  $i^{\text{th}}$  time when the selected mode changes (if it exists), i.e.,

$$t_i := \inf\{t \geq t_{i-1} : \exists k \in \{1, \dots, N + 1\} \setminus \{\sigma(t)\} \text{ such that } \eta_k(t) \leq \eta_{\sigma(t)}(t)\}.$$

Consequently, for all  $i \in \mathbb{Z}_{>0}$ ,  $\dot{\sigma}(t) = 0$  for all  $t \in (t_{i-1}, t_i)$  and

$$\sigma(t_i^+) \in \underset{k \in \Pi}{\operatorname{argmin}} (g(\eta_k(t_i), L_k, y(t_i), \hat{y}_k(t_i))). \quad (4.54)$$

Note that the choice of  $\eta_k(0)$  is an extra degree of freedom that can be used to initially penalize the modes when there is a prior knowledge of which mode should be initially selected, as done in [D60] in the context of Li-Ion batteries. Conversely, in the case where there is no prior knowledge on which mode should be chosen at the beginning, all  $\eta_k$ , with  $k \in \{1, \dots, N + 1\}$ , can be initialized at the same value such that the term  $e^{-\nu t} \eta_k(0)$  in (4.53) is irrelevant for the minimization.

When a switching occurs, i.e., when a different mode is selected, we propose two different options to update the hybrid estimation scheme. The first one, called *without resets*, consists in only updating  $\sigma$ , and consequently, we only switch the state estimate we are looking at. Conversely, the second option, called *with resets*, consists in not only switching the mode that is considered, but also resetting the state estimates and the monitoring variables of all the modes  $k \in \{2, \dots, N + 1\}$  to the updated  $\hat{x}_\sigma$  and  $\eta_\sigma$ , respectively. The state estimate and the monitoring variable of the nominal observer (4.49), corresponding to mode 1, are never reset.

To avoid infinitely fast switching, we introduce a regularization parameter  $\varepsilon \in \mathbb{R}_{>0}$ . In particular, when a switch of the selected mode occurs, the value of monitoring variables  $\eta_k$ , with  $k \in \{2, \dots, N + 1\} \setminus \{\sigma\}$ , is increased by  $\varepsilon$ , both in the case without and with resets. The idea is to penalize the unselected modes and to allow the selected one to run for some amount of time before a new switch occurs. We use the parameter  $r \in \{0, 1\}$  to determine which option is selected, where  $r = 0$  corresponds to the case without resets, while  $r = 1$  corresponds to the case where the resets are implemented. When a switch of the considered mode occurs, the state estimate  $\hat{x}_k$  of the  $k^{\text{th}}$  mode is defined as, at a switching time  $t_i \in \mathbb{R}_{\geq 0}$ ,

$$\hat{x}_1(t_i^+) := \hat{x}_1(t_i) \quad (4.55)$$

and, for all  $k \in \{2, \dots, N + 1\}$ ,

$$\hat{x}_k(t_i^+) \in \hat{\ell}_k(\hat{x}(t_i), \eta(t_i), L_k, y(t_i), \hat{y}_k(t_i)), \quad (4.56)$$

where  $\hat{x} := (\hat{x}_1, \dots, \hat{x}_{N+1})$ ,  $\eta = (\eta_1, \dots, \eta_{N+1})$  and

$$\begin{aligned} \hat{\ell}_k(\hat{x}(t_i), \eta(t_i), L_k, y(t_i), \hat{y}_k(t_i)) := \\ \{(1-r)\hat{x}_k(t_i) + r\hat{x}_{k^*}(t_i) : k^* \in \underset{j \in \Pi}{\operatorname{argmin}}(g(\eta_k(t_i), L_k, y(t_i), \hat{y}_k(t_i)))\}. \end{aligned}$$

Similarly, at a switching time  $t_i \in \mathbb{R}_{\geq 0}$ , the monitoring variables are defined as,

$$\eta_1(t_i^+) := \eta_1(t_i), \quad (4.57)$$

$$\eta_\sigma(t_i^+) := \eta_\sigma(t_i) \quad (4.58)$$

and, for all  $k \in \{2, \dots, N + 1\} \setminus \{\sigma\}$ ,

$$\eta_k(t_i^+) = p_k(\eta(t_i)), \quad (4.59)$$

where  $\varepsilon \in \mathbb{R}_{>0}$  and  $p_k(\eta) := (1-r)\eta_k + r\eta_{k^*} + \varepsilon$  with  $\eta_{k^*} = \min_{j \in \{1, \dots, N+1\} \setminus \{\sigma\}} \eta_j$ .

Note that, if the monitoring variables of more than one mode have the same value and it is the minimum between all the  $\eta_k$ , with  $k \in \{1, \dots, N + 1\}$ , then, from (4.56), the modes may be reset with different state estimates. We can already note that, with the proposed technique,  $\eta_{\sigma(t)}(t) \leq \eta_1(t)$  for all  $t \geq 0$ , both in the case without and with resets. Therefore, the estimation performance of the proposed hybrid multi-observer is always not worse than the performance of the nominal one according to the monitoring variables that we consider.

Finally, note that the state estimate  $\hat{x}_\sigma$  of the hybrid multi-observer is subject to jumps and therefore it can be discontinuous, which may not be suitable in some applications. Therefore, it is possible to add a filtered version of  $\hat{x}_\sigma$ , denoted  $\hat{x}_f$ , whose dynamics between two successive switching instants is

$$\dot{\hat{x}}_\sigma = -\zeta \hat{x}_f + \zeta \hat{x}_\sigma$$

where  $\zeta > 0$  is an additional design parameter and,  $\hat{x}_f$  does not change at switching times  $t_i \in \mathbb{R}_{\geq 0}$ , i.e.,  $\hat{x}_f(t_i^+) = \hat{x}_f(t_i)$ .

### 4.5.3 Main result

To proceed with the analysis of the hybrid estimation scheme presented so far, we model the overall system as a hybrid system of the form of [90], where a jump corresponds to a switch of the selected mode and a possible reset. We define the overall state as

$$q := (x, \hat{x}_1, \dots, \hat{x}_{N+1}, \eta_1, \dots, \eta_{N+1}, \sigma) \in \mathcal{Q} := \mathbb{R}^{n_x} \times \mathbb{R}^{(N+1)n_x} \times \mathbb{R}_{\geq 0}^{N+1} \times \{1, \dots, N + 1\},$$

and we obtain the hybrid system

$$\begin{cases} \dot{q} = F(q, u, v, w), & q \in \mathcal{C} \\ q^+ \in G(q), & q \in \mathcal{D}, \end{cases} \quad (4.60)$$

where flow map is defined as, for any  $q \in \mathcal{C}$ ,  $u \in \mathcal{U}$ ,  $v \in \mathcal{V}$  and  $w \in \mathcal{W}$ , from (4.48), (4.49), (4.51), (4.52),

$$\begin{aligned} F &:= (f_p, f_{o,1}, \dots, f_{o,N+1}, g_1, \dots, g_{N+1}, 0) \\ G &:= (x, \hat{x}_1, \hat{\ell}_2, \dots, \hat{\ell}_{N+1}, \eta_1, p_2, \dots, p_{N+1}, \underset{k \in \Pi}{\operatorname{argmin}} g_k) \end{aligned}$$

with the short notation  $f_{o,k} = f_o(\hat{x}_k, u, L_k(y - y_k))$ ,  $g_k = g(\eta_k, L_k, y, y_k)$ ,  $\hat{\ell}_k = \hat{\ell}_k(\hat{x}, \eta, L_k, y, \hat{y}_k)$  and  $p_k = p_k(\eta)$ , where  $\Pi(q) = \underset{k \in \{1, \dots, N+1\} \setminus \{\sigma\}}{\operatorname{argmin}} \eta_k$  for all  $q \in \mathcal{D}$ ,  $k \in \{1, \dots, N+1\}$ .

Furthermore, the flow and jump sets  $\mathcal{C}$  and  $\mathcal{D}$  in (4.60) are defined as

$$\mathcal{C} := \{q \in \mathcal{Q} : \forall k \in \{1, \dots, N+1\} \ \eta_k \geq \eta_\sigma\}, \quad (4.61)$$

$$\mathcal{D} := \{q \in \mathcal{Q} : \exists k \in \{1, \dots, N+1\} \setminus \{\sigma\} \ \eta_k \leq \eta_\sigma\}. \quad (4.62)$$

**Theorem 4.5.** *Consider system (4.60)-(4.62) and suppose Assumptions 4.13-4.14 hold. Then there exist  $\beta_U \in \mathcal{KL}$  and  $\gamma_U \in \mathcal{K}_\infty$  such that for any input  $u \in \mathcal{L}_U$ , disturbance input  $v \in \mathcal{L}_V$  and measurement noise  $w \in \mathcal{L}_W$ , any solution  $q$  satisfies*

$$|(e_1(t, j), \eta_1(t, j), e_\sigma(t, j), \eta_\sigma(t, j))| \leq \beta_U(|(e(0, 0), \eta(0, 0))|, t) + \gamma_U(|v|_{[0, t]} + |w|_{[0, t]}) \quad (4.63)$$

for all  $(t, j) \in \operatorname{dom} q$ , with  $e := (e_1, \dots, e_{N+1})$  and  $\eta := (\eta_1, \dots, \eta_{N+1})$ . Furthermore, solutions to (4.60)-(4.62) have the following properties:

- no Zeno-behaviour may occur;
- if any maximal solution to (4.48) with  $u$  in  $\mathcal{L}_U$ ,  $v$  in  $\mathcal{L}_V$  and  $w$  in  $\mathcal{L}_W$  is complete, so is any maximal solution to system (4.60)-(4.62);
- if the set  $\mathcal{V}$  and  $\mathcal{W}$  are compact then system (4.60)-(4.62) has a uniform semiglobal average dwell-time.

Theorem 4.5 guarantees a two-measure input-to-state stability property [49]. The proof is based on the Lyapunov function

$$U(q) := c_1(aV(e_1) + \eta_1) + c_2 \max_{k \in \{1, \dots, N+1\}} \{bV(e_k) - \eta_k, 0\} + c_3 \max\{\eta_\sigma - \eta_1, 0\}.$$

In particular, (4.63) ensures that  $e_1$ ,  $\eta_1$ ,  $e_\sigma$  and  $\eta_\sigma$  converge to a neighborhood of the origin, whose “size” depend on the  $\mathcal{L}_\infty$  norm of  $v$  and  $w$ . Note that we do not guarantee any stability property for the modes  $k \neq \sigma$ , but this is not needed for the convergence of the hybrid observer estimation error  $e_\sigma$ . Hence, the convergence of the estimated state vector of the selected mode is guaranteed by Theorem 4.5.

We recall that with the proposed technique we have  $\eta_{\sigma(t, j)}(t, j) \leq \eta_1(t, j)$  for all  $(t, j) \in \operatorname{dom} q$ , for any solution  $q$  to (4.60)-(4.62) with inputs  $u \in \mathcal{L}_U$ ,  $v \in \mathcal{L}_V$  and  $w \in \mathcal{L}_W$ , both in the case without and with resets. Therefore, the estimation performance of the proposed hybrid multi-observer are always not worse than the performance of the nominal one according to the monitoring variables we consider.

The variable  $\eta_\sigma$  is a performance variable that considers the “best” mode among the  $N+1$  at any time instant: this is an instantaneous performance, which ignores the past behavior in terms of the monitoring variable. For this reason, to evaluate the performance of the proposed hybrid multi-observer, we also propose the following cost, for any solution  $q$  to (4.60)-(4.62) with inputs  $u \in \mathcal{L}_U$ ,  $v \in \mathcal{L}_V$  and  $w \in \mathcal{L}_W$ ,

$$J_{\sigma(t, j)}(t, j) := \sum_{i=0}^j \left( \int_{t_i}^{t_{i+1}} \eta_{\sigma(s, i)}(s, i) ds \right), \quad \forall (t, j) \in \operatorname{dom} q, \quad (4.64)$$

with  $0 = t_0 \leq t_1 \leq \dots \leq t_{j+1} = t$  satisfying

$$\operatorname{dom} q \cap ([0, t] \times \{0, 1, \dots, j\}) = \bigcup_{i=0}^j [t_i, t_{i+1}] \times \{i\}.$$

Similarly, we define the performance cost of the nominal observer as

$$J_1(t, j) := \sum_{i=0}^j \left( \int_{t_i}^{t_{i+1}} \eta_1(s, i) ds \right), \quad \forall (t, j) \in \text{dom } q, \quad (4.65)$$

with  $0 = t_0 \leq t_1 \leq \dots \leq t_{j+1} = t$  satisfying

$$\text{dom } q \cap ([0, t] \times \{0, 1, \dots, j\}) = \bigcup_{i=0}^j [t_i, t_{i+1}] \times \{i\}.$$

In the next theorem we prove, that the proposed hybrid scheme strictly improves the performance  $J_1$  in (4.65), under some conditions on the gain selection and on the initial conditions of the modes of the multi-observer and monitoring variables.

**Theorem 4.6.** *Consider system (4.60)-(4.62) under Assumptions 4.13-4.14 and suppose that maximal solutions are complete. Let  $q$  be a maximal solution with inputs  $u \in \mathcal{L}_{\mathcal{U}}$ ,  $v \in \mathcal{L}_{\mathcal{V}}$  and  $w \in \mathcal{L}_{\mathcal{W}}$  and for which the initial conditions of the monitoring variables are all the same, namely  $\eta_k(0, 0) = \eta_0$  for all  $k \in \{1, \dots, N + 1\}$  for some  $\eta_0 \in \mathbb{R}$ . Then, for any  $(t, j) \in \text{dom } q$ ,*

$$J_{\sigma(t,j)}(t, j) \leq J_1(t, j),$$

with  $J_{\sigma}$  and  $J_1$  defined in (4.64) and (4.65), respectively. Moreover, if there exists  $(t^*, j^*) \in \text{dom } q$  such that

$$\eta_{\sigma(t^*, j^*)}(t^*, j^*) < \eta_1(t^*, j^*), \quad (4.66)$$

then there exists  $j^{*'} \geq j^*$  such that  $J_{\sigma(t,j)}(t, j) < J_1(t, j)$  for all  $(t, j) \geq (t^*, j^{*'})$ , with  $(t, j) \in \text{dom } q$ .

Theorem 4.6 shows that, if the condition in (4.66) holds, then the cost of the proposed hybrid multi-observer  $J_{\sigma}$  is strictly smaller than the one of the nominal observer  $J_1$  and thus, the estimation performance in terms of costs  $J_{\sigma}$  and  $J_1$  is strictly improved. In the next theorem, we give the conditions to guarantee that (4.66) is satisfied and consequently, from Theorem 4.6, that the estimation performance is strictly improved with the hybrid multi-observer (4.60)-(4.62).

**Theorem 4.7.** *Consider system (4.60)-(4.62) with  $\Lambda_2$  being positive definite, and suppose Assumptions 4.13-4.14 hold and that maximal solutions are complete. Select the gains  $L_k$ , with  $k \in \{2, \dots, N + 1\}$ , in (4.51) such that there exists  $k^* \in \{2, \dots, N + 1\}$  satisfying  $L_{k^*}^{\top} \Lambda_2 L_{k^*} < L_1^{\top} \Lambda_2 L_1$ . Let  $q$  be a maximal solution with inputs  $u \in \mathcal{L}_{\mathcal{U}}$ ,  $v \in \mathcal{L}_{\mathcal{V}}$  and  $w \in \mathcal{L}_{\mathcal{W}}$  and initial condition  $q(0, 0)$  satisfying the following properties.*

1.  $\hat{x}_k(0, 0) = \hat{x}_0$  for all  $k \in \{1, \dots, N + 1\}$  for some  $\hat{x}_0 \in \mathbb{R}^{n_x}$ .
2.  $\eta_k(0, 0) = \eta_0$  for all  $k \in \{1, \dots, N + 1\}$  for some  $\eta_0 \in \mathbb{R}$ .
3.  $\hat{y}_k(0, 0) \neq y(0, 0)$  for all  $k \in \{1, \dots, N + 1\}$ .

Then, there exists  $(t^*, j^*) \in \text{dom } q$  such that  $\eta_{\sigma(t^*, j^*)}(t^*, j^*) < \eta_1(t^*, j^*)$ .

Note that, the conditions in items (i) and (ii) of Theorem 4.7 can always be ensured by designing the same initial condition for the state estimate and monitoring variables for all the modes. Moreover, condition in item (iii) is verified almost everywhere (it is a set of null measure).

We also acknowledge that we state the performance improvement with respect to costs  $J_1$  and  $J_{\sigma}$ , and that it would be interesting to state properties for a cost, which involves the state estimation errors  $e_1$  and  $e_{\sigma}$ . This is a challenging question that we will address in future works.

## 4.6 Conclusions and perspectives

In this chapter we proposed a series of tools for the performances improvement of given non-linear observers. The underlying common approach is to try to redesign the given observer with modular techniques that doesn't destroy the original design. The first proposed technique is the stubborn/dead zone redesign approach explained in Section 4.2, mainly based on the article [D6]. The case study of stubborn high-gain observer has been published in [D11]. Furthermore, the technique is working not only for pure estimation but also for output-feedback stabilization, see [D64]. Similar results in the context of multi-agent synchronization have been proposed in [D40] [D41]. Section 4.3 is devoted to the problem of constrained state estimation. Based on a convex assumption, three different redesign approaches has been proposed: a continuous-one, a discrete-time and a hybrid one. The case of discrete-time redesign for discrete-time observers has been published in the conference paper [D7], while the general theory has been given in [D8]. We remark that the preliminary idea have been already published in [D24] and [D25]. Finally, the problem of uniting multiple observers is studied. The problem of combining a local observer with a global one via hybrid technique has been detailed in Section 4.4. This section is based on the papers [D21] and [D22]. Then, the case of combining multiple observers has been addressed in Section 4.5. The content is based on the papers [D56,D57]. We remark that this observer has been also analyzed in the context of electrochemical lithium-ion battery model in [D60], but the results are omitted for space reasons.

Overall, we proposed a series of innovative approaches to improve the performances of a given observer. The general framework of multi-observer, developed during the Ph.D. thesis of E. Petri, is very promising and only a preliminary step, because many open questions still remain. The more crucial is probably to understand how one can optimize a cost in the estimation error while not actually measuring it, and how the proposed cost (based on the output estimation error and the output injection term) relates to it. Moreover, motivated by the existence of a Lyapunov function for the overall scheme, we proposed a selection mechanism based on individual running costs, but this is only one possible choice as many others may be envisioned. For instance, taking inspiration from fault detection techniques, one could average the estimations and discard the farrest ones. Similarly, the use of the proposed multi-observer scheme in output feedback control is an open question.





# 5

## Conclusions and perspectives

---

### 5.1 Some other contributions

In this section, I list some works that have not been presented in this manuscript.

**Output regulation for networked control systems.** In the series of works [D10,D23] I started analyzing the robustness properties of internal model based regulators under network constraints, such as sampling and scheduling. Following an emulation approach, we first supposed that a regulator is designed for the nominal continuous-time systems. Then, the robustness properties for the resulting networked control systems have been studied, identifying the cases in which asymptotic regulation can be still achieved. Within the framework of hybrid formalism, linear [D23] and nonlinear systems [D10] have been addressed.

**Multi-agent synchronization via robust nonlinear internal model design.** In the article [D39] I studied the problem of consensus of a network of heterogeneous nonlinear agents on a family of different desired trajectories generated by an uncertain leader. We designed a set of local reference generators and local controllers which guarantees that the agents achieve consensus robustly on all possible trajectories inside this family. The design of the local reference generators is based on the possibility to express the trajectory of the leader as a nonlinear regression law which is parametrized by some constant unknown parameters. This work is based on the use of nonlinear regressors introduced in [82].

**Output regulation in practical applications.** As detailed in Chapter 3, a possible approach to solve the problem of output regulation is to first design a linear internal model unit and then stabilize the feedback via the forwarding approach, see, for instance, [D25] in the context of integral action controllers, and [D26,D28] for harmonic regulation. In the series of works [D33, D61–D63,D67] we experimentally tested these approaches. In particular, we applied an integral action controller in the context of DC/DC converters [D33] relying on the total stability result provided in the appendix of [D25]. Then, we applied the forwarding based approach in the context of heat exchangers [D67] and power-flow controllers [D62,D63]. Finally, the harmonic regulation / repetitive control scheme has been investigated in the context of mechanical ventilation problems [D61].

**Learning for harmonic regulation.** One of the main drawbacks of the harmonic regulation framework proposed in Chapter 3, is that such a technique strongly relies on the knowledge of the periodicity of the exogenous signals, which may be unknown or uncertain in many cases.

Following the framework of [D26, D28] In the work [D50] we investigated the use of iterative learning approaches to identify frequencies and solve therefore an harmonic regulation problem.

**Reinforcement Learning Policies with local LQR guarantees for Nonlinear Discrete-Time Systems.** In the context of the Ph.D. thesis of S. Zoboli, we studied the use of Reinforcement Learning (RL) techniques in feedback design. In the work [D68] we addressed the problem of controller for discrete-time nonlinear systems. First, we supposed to know the linearized model of a given system around the desired equilibrium and an LQR local controller is selected. Then, we tried to enlarge the domain of attraction of such a local controller via learning methodologies. In particular, we employed an RL algorithm to learn a controller which locally matches the desired LQR one. The proposed approach enhances the capabilities of the linear controller by learning to operate outside its domain of attraction while maintaining its local properties. Although no theoretical guarantees can be given, we obtained excellent numerical results.

**Total stability of discrete-time systems.** In the context of the Ph.D. thesis of S. Zoboli, we proposed the discrete-time parallel of total stability results for continuous-time nonlinear system established in [D25]. This result, published in [D69], enables the analysis of robustness properties via simple model difference in the discrete-time context. First, we studied how existence of equilibria for a nominal model transfers to sufficiently similar ones. Then, we provide results on the propagation of stability guarantees to perturbed systems. Finally, we relate such properties to the constant output regulation problem by motivating the use of discrete-time integral action in discrete-time nonlinear systems.

**Survey on observers design.** In the work [D34], we conducted a literature survey on the design of observers for continuous-time nonlinear systems, reviewing more than 200 references. Although the survey does not provide any new results in itself, it reorganizes existing research in a systematic manner and sheds light on the main results regarding the correlation between observer design and the observability properties of the observed system.

**High-gain observers design.** In the context of nonlinear system theory, high-gain observers received a lot of attention for their tunability property (i.e. the fact that the speed of convergence can be arbitrarily made fast) and their use in output-feedback stabilization, see, e.g. [115]. These observers, however, suffer from a certain number of drawbacks: sensitivity to high-frequency measurement noise, peaking phenomenon, and bad conditioning in implementation. For these reasons, their use in practical application is still quite limited. In this context, since the beginning of my Ph.D. I contributed to this field with a certain number of works.

In the work [D15], we characterized the steady-state behaviour of an observer in the presence of high-frequency measurement noise, providing bound which depends on the frequency of the noise. The methodology is strongly inspired from output regulation literature. In particular, the noise is modeled as the solution to an autonomous system and the steady-state behaviour is characterized by analyzing the so-called regulator equations. Similar ideas have been used in the context of moment matching [21].

The main contribution in this field is surely the design of a new class of observers denoted as “low-power high-gain observers”, see [D14, D16, D17, D65]. The main idea behind this design is to construct an interconnected cascade of  $n-1$  high-gain observers of dimension 2 to observe the state of a system (in the standard observability canonical form) of dimension  $n$  [D14, D65]. The dimension of the overall observer is  $2n-2$  but, thanks to the fact that the relative degree between

the measurement noise and each component estimate is in general larger than 2, the sensitivity to high-frequency measurement noise is vastly improved. The proposed observer preserves the tunability property and moreover the high-gain parameter is powered up to 2 regardless the dimension of the observed state (contrarily to standard high-gain observers in which the high-gain parameter is powered up to  $n$ ). This, in turns, allows to have parameters which are better numerically conditioned. Finally, thanks to the use of saturations, the peaking phenomenon can be drastically improved [D16,D17]. In the article [D54] we also proposed an adaptation law for the high-gain parameter extending standard results in high-gain observers [15]. The low-power technique has been also used in the context of output feedback stabilization [D9, D66] and output regulation in the design of nonlinear internal models [D11, D36] extending the design proposed in [46]. Finally, taking inspiration from the main message that low-pass filters in the loop may improve the sensitivity to measurement noise, alternative constructions in the context of high-gain observers have been proposed in [D13, D30].

**Design of local observers.** In the article [D20] we proposed a new framework for the design of local asymptotic observers, with arbitrarily fast rate of convergence, for autonomous nonlinear systems that are not in observability canonical form. The proposed methodology does not require the knowledge of the inverse of the observability map. Such a goal is pursued by coupling a high-gain observer with a system that is able to locally dynamically invert the observability map. The latter can be implemented by using the inverse of the observability map, thus recovering a Newton-like algorithm, or its transpose, thus recovering a gradient-like algorithm.

**Design of global observers for non-Lipschitz systems.** In the article [D1, D2], we proposed a new methodology for designing observers for nonlinear systems in a lower-triangular form with globally linearly bounded nonlinearities that may be non-Lipschitz and do not satisfy any homogeneity constraint. This extends the design proposed in [14] based on homogeneity conditions. Our proposed construction combines the structure of low-power high-gain observers with sliding-mode observer correction gains to guarantee global convergence of the estimation error in finite-time, with gains that depend only on the parameters of the incremental affine bound of the nonlinearities. We also introduce a new "small-gain"-like theorem for non-Lipschitz Lyapunov functions to prove the main results

**Event-triggered observers.** In the articles [D58, D59], developed in the Ph.D. thesis of E. Petri, we proposed a new methodology to design a decentralized event-triggered nonlinear observer. In particular, we investigate the scenario where a perturbed nonlinear system transmits its output measurements to a remote observer via a packet-based communication network. The sensors are grouped into  $N$  nodes and each of these nodes decides when its measured data is transmitted over the network independently. Each sensor is supposed to be "smart" in the sense that it is equipped with some (small) computational power, implementing a simple dynamic event-triggered algorithm. In such a way, we obtain accurate state estimates, while only sporadically using the communication network.

**Use of DNN in KKL observers.** In the article [D55] we investigated the use of deep neural networks (DNN) in Kazantzis-Kravaris-Luenberger (KKL) observer for non-autonomous multi-output discrete-time nonlinear systems. In particular, the KKL design is based on the knowledge of a mapping that transforms a nonlinear dynamics into a stable linear system modulo an output injection. However, such a mapping is difficult to compute and its numerical approximation may

be badly conditioned during the transient phase. To overcome these issues, we proposed an algorithm based on ensemble learning techniques to improve the numerical approximation of the mapping and its extension in the transient phase. This ensures a good asymptotic convergence of the observer and avoids peaking phenomena. In this article we tested the proposed algorithm in high-dimensional and multi-input-multi-output examples.

## 5.2 Perspectives

Finally, based on the content of this dissertation, I list here a certain number of open problems and perspectives for my future works.

**Design of  $k$ -contractive feedbacks.** Chapter 1 is devoted to the design of stabilizing feedback ensuring contractivity properties of the overall closed-loop systems. In recent years, a new notion of contraction, denoted as  $k$ -contraction, has been introduced for nonlinear systems [145, 216]. Similarly to the notion of contraction, defining a (contractivity) property on distances between trajectories, the notion of  $k$ -contraction define a contractivity property on  $k$ -surfaces (or  $k$ -volumes). For instance, in case of a 2-contractivity property, any surface is supposed to converge to zero, although some trajectories may actually diverge. However, for bounded trajectories of a 2-contractive system, limit cycles are excluded, i.e. these trajectories necessarily converge to equilibria [216]. Such a property is provides less guarantees than 1-contractivity but it is nevertheless of particular interest for integral action control: on any of such equilibria, output regulation is achieved. Most of existing works in  $k$ -contraction theory focus on the analysis, and the problem of feedback design ensuring  $k$ -contractivity properties is mainly open, e.g. [216]. The main limitation is related to the measure matrix and  $k$ -compounds that hardly applies for design [66,216]. We believe that a methodology to overcome existing limitation is to combine the Riemannian contraction [186] approach with  $p$ -dominance (which is however well developed only for Euclidean metrics), [80,81] horizontal contraction [79,215], and transverse exponential stability [10]. Following this idea we submitted some preliminary results [D70].

**Infinite dimensional and large scale internal models for output regulation.** Section 3.4 introduces a new paradigm of infinite-dimensional regulators based on the preliminary work [D3], which opens however a certain number of theoretical and practical questions. The internal model unit that we proposed cover the case of signals which are reproducible by a finite number of non-commensurable periodic functions, but other classes of signals may be envisioned. The (incremental) stabilization of cascade composed by a (possibly multi-input multi-output) input-affine nonlinear ODE and a PDE is also an open axe of research, since in Section 3.4 only the case of minimum-phase systems has been addressed. Furthermore, semi-global results should be also investigated. Then, many open questions concerns the discretization of such a infinite-dimensional systems. For the case of repetitive controllers, we showed that a harmonic approximation may recover the asymptotic properties of the exact repetitive controller, but other discretization approaches are possible, e.g. [99,201]. As a matter of fact, the problem of reducing the dimension of a given large scale (possibly infinite dimensional) model has been addressed by many researchers in many different fields [94], such as finite-element methods [169], model reduction theory [21,178], spectral approaches [91,209] polynomial approximations [23], Galerking methods [91],  $\tau$ -models and so on [148]. The peculiarity and the challenge of such a study is however is that we would like to approximate an infinite dimensional internal model with a large-scale one while preserving some asymptotic properties

on the solutions. In the preliminary work [D31], we compared some  $\tau$ -methods, that is, the harmonic approximation (based on a Fourier decomposition), and two polynomial approximations based respectively on Legendre polynomials (which can be shown to be equivalent to a Padè approximation) and a Chebyshev polynomials. The resulting harmonic model seems to be the most promising one. Finally, last but not least, in the context of repetitive control it is usually assumed to have the perfect knowledge of the period of signals. In the absence of such a knowledge, alternative routes need to be explored, such as the use of (continuous-time or hybrid) adaptive techniques, e.g. [31, 138, 139, 183, 192], [D50]. The theory of adaptive infinite dimensional internal models is surely another interesting open research direction, see, e.g. [1].

**Contraction and cooperative output regulation of bilinear systems.** During my research career, I had the opportunity to practically apply some of the output regulation techniques that I developed. This included works on heat exchangers [D67], power converters [D62, D63], and mechanical ventilation [D61]. Despite these promising results, much work still needs to be done. Indeed, in the context of heat exchangers and power converters, only integral-action based regulators have been tested while the use of more general internal model based regulator has still not employed. One of the main difficulties comes from the fact that both applications can be described by a bilinear model and this make the feedback design particularly challenging. As a matter of fact, it is worth noticing that, although the bilinear systems representation is quite general (as remarked in [78] “any control-affine system with finite dimensional observation space may be immersed in a bilinear systems”), the control theory of bilinear systems is not very much developed. In literature we can find works on controllability [116], stabilization [16, 54, 95, 130] and observer design (see, for instance, [30, 39] and Section V in [D34]). However, when looking for some more complex control problems the literature is scarce. We can cite some results about tracking control and reject of constant perturbations [58, 92], and few works addressing the problem of output feedback stabilization [16, 42, 175, 200]. But for more general output regulation and synchronization of multi-agent systems problems there are almost no results (see, e.g. [126, 204]). As a consequence, driven by the control problem heat exchanger networks [D67], I would like to develop a general framework for the design of distributed internal model based regulators (also denoted in literature as cooperative output regulation [71, 72, 193, 194]) for the control of networks of bilinear systems. To this end, developing new design methodologies to make a bilinear system contractive via feedback is crucial. One key element could be focusing on positive systems [73, 76, 167] and using non-Euclidean norms such as the  $\ell_\infty$  or  $\ell_1$  norm [69]. For instance, the theory of a Riemannian weak pairing based on a distance function of the type  $|\int_0^1 p^\top(x) \frac{\partial f}{\partial x}(x) dx|$  is still missing, to the best of my knowledge

**Multi-observers for performance improvements.** The flexibility of the multi observers framework developed in Section 4.5 opens up a range of fascinating, important research directions. First, we currently do not have a systematic methodology to design the observer gains  $L_i$  for the additional modes and this will need to be developed. In this context, one possible approach is the off-line tuning of the additional observer gains taking advantage of the fact that the estimation error  $x - \hat{x}$  is known on simulations off-line. Dynamic programming tools can be exploited for that. Then, the obtained gains will be used to run on-line this time the hybrid multi-observer scheme to select the best designed gains according to the measured input and output. An alternative, which will also be explored, will be, instead of tuning the gains off-line and picking the best one on-line, to adopt a fully on-line approach where the observers gains values are no longer fixed but adjusted to further improve the considered on-line cost function. This approach is more challenging but may lead to better estimation performance. Second, the considered cost

functions involve only the output estimation error, whereas our ultimate goal is to improve a cost, which involves the state estimation error that is unknown on-line. It would be interesting to use Lyapunov characterizations of observability and detectability properties of the system to make these connections. Third, Kazantsis-Kravaris-Luenberger (KKL) observers [12] are currently escaping our theory, and we will aim at developing tuning strategies for such observers. The motivation to consider KKL observers comes from their simple structure (essentially linear filters), while the require nonlinear transformation to change the systems coordinates can be learned and the nonlinearities can be learned via offline training phases with deep learning methods [D55] [109, 146, 166]. Also, it would be relevant to propose a design framework, which allows to consider observers with a different structure, like extended Kalman filters with high gain observers, to make the best out of each of them. Finally, I would like also to investigate to what extent the proposed scheme can be used to improve the performance of a given observer-based controller, which is largely unexplored in the literature precisely because of the lack of tools to tune observers while preserving their convergence properties.

## Bibliography

---

- [1] S. Afshar and L. Paunonen. Adaptive robust output regulation control design. In *American Control Conference*, pages 3038–3043, 2019.
- [2] J. Ahrens and H. Khalil. High-gain observers in the presence of measurement noise: a switched-gain approach. *Automatica*, 45(4):936–943, 2009.
- [3] A. Alessandri and M. Awawdeh. Moving-horizon estimation with guaranteed robustness for discrete-time linear systems and measurements subject to outliers. *Automatica*, 67:85–93, 2016.
- [4] A. Alessandri, C. Cervellera, D. Macciò, and M. Sanguineti. Optimization based on quasi-Monte Carlo sampling to design state estimators for nonlinear systems. *Optimization*, 59(7):963–984, 2010.
- [5] A. Alessandri and L. Zaccarian. Results on stubborn Luenberger observers for linear time-invariant plants. In *European Control Conference*, pages 2925–2930, 2015.
- [6] A. Alessandri and L. Zaccarian. Stubborn state observers for linear time-invariant systems. *Automatica*, 88:1–9, 2018.
- [7] Z. Aminzare and E. Sontag. Contraction methods for nonlinear systems: A brief introduction and some open problems. In *53rd IEEE Conference on Decision and Control*, pages 3835–3847, 2014.
- [8] Z. Aminzare and E. Sontag. Synchronization of diffusively-connected nonlinear systems: Results based on contractions with respect to general norms. *IEEE Transactions on Network Science and Engineering*, 1(2):91–106, 2014.
- [9] V. Andrieu, B. Jayawardhana, and L. Praly. Transverse exponential stability and applications. *IEEE Transactions on Automatic Control*, 61(11):3396–3411, 2016.
- [10] V. Andrieu, B. Jayawardhana, and L. Praly. Characterizations of global transversal exponential stability. *IEEE Transaction on Automatic Control*, 66(8):3682–3694, 2021.
- [11] V. Andrieu, B. Jayawardhana, and S. Tarbouriech. Some results on exponential synchronization of nonlinear systems. *IEEE Transactions on Automatic Control*, 63(4):1213–1219, 2018.
- [12] V. Andrieu and L. Praly. On the existence of a Kazantzis–Kravaris/Luenberger observer. *SIAM Journal on Control and Optimization*, 45(2):432–456, 2006.
- [13] V. Andrieu and L. Praly. A unifying point of view on output feedback designs for global asymptotic stabilization. *Automatica*, 45(8):1789–1798, 2009.



- [14] V. Andrieu, L. Praly, and A. Astolfi. Homogeneous approximation, recursive observer design, and output feedback. *SIAM Journal on Control and Optimization*, 47(4):1814–1850, 2008.
- [15] V. Andrieu, L. Praly, and A. Astolfi. High gain observers with updated gain and homogeneous correction terms. *Automatica*, 45(2):422–428, 2009.
- [16] V. Andrieu and S. Tarbouriech. Global asymptotic stabilization for a class of bilinear systems by hybrid output feedback. *IEEE Transactions on Automatic Control*, 58(6):1602–1608, 2012.
- [17] D. Angeli. A Lyapunov approach to incremental stability properties. *IEEE Transactions on Automatic Control*, 47(3):410–421, 2002.
- [18] D. Angeli. Further results on incremental input-to-state stability. *IEEE Transactions on Automatic Control*, 54(6):1386–1391, 2009.
- [19] M. Arcak. Certifying spatially uniform behavior in reaction–diffusion PDE and compartmental ODE systems. *Automatica*, 47(6):1219–1229, 2011.
- [20] M. Arcak and P. Kokotović. Nonlinear observers: a circle criterion design and robustness analysis. *Automatica*, 37(12):1923–1930, 2001.
- [21] A. Astolfi. Model reduction by moment matching for linear and nonlinear systems. *IEEE Transactions on Automatic Control*, 55(10):2321–2336, 2010.
- [22] A. Atassi and H. Khalil. A separation principle for the stabilization of a class of nonlinear systems. *IEEE Transactions on Automatic Control*, 44(9):1672–1687, 1999.
- [23] M. Bajodek, A. Seuret, and F. Gouaisbaut. Insight into stability analysis of time-delay systems using legendre polynomials. In *IFAC*, 2020.
- [24] G. Bastin and J.-M. Coron. *Stability and boundary stabilization of 1-d hyperbolic systems*, volume 88. Springer, 2016.
- [25] P. Bernard. *Observer Design for Nonlinear Systems*. Springer, 2019.
- [26] P. Bernard and L. Marconi. Hybrid implementation of observers in plant’s coordinates with a finite number of approximate inversions and global convergence. *Automatica*, 111:108654, 2020.
- [27] P. Bernard, L. Praly, and V. Andrieu. Observers for a non-lipschitz triangular form. *Automatica*, 82:301–313, 2017.
- [28] G. Besançon. Further results on high gain observers for nonlinear systems. In *38th IEEE Conference on Decision and Control*, volume 3, pages 2904–2909, 1999.
- [29] G. Besançon, G. Bornard, and H. Hammouri. Observer synthesis for a class of nonlinear control systems. *European Journal of Control*, 2(3):176–192, 1996.
- [30] G. Besançon, J. de León-Morales, and O. Huerta-Guevara. On adaptive observers for state affine systems. *International journal of Control*, 79(06):581–591, 2006.

- 
- [31] M. Bin, P. Bernard, and L. Marconi. Approximate nonlinear regulation via identification-based adaptive internal models. *IEEE Transactions on Automatic Control*, 66(8):3534–3549, 2020.
- [32] M. Bin and L. Marconi. Output regulation by postprocessing internal models for a class of multivariable nonlinear systems. *International Journal of Robust and Nonlinear Control*, 30(3):1115–1140, 2020.
- [33] M. Bin, L. Marconi, and A. R. Teel. Adaptive output regulation for linear systems via discrete-time identifiers. *Automatica*, 105:422–432, 2019.
- [34] N. Blin, P. Riedinger, J. Daafouz, L. Grimaud, and P. Feyel. Necessary and sufficient conditions for harmonic control in continuous time. *IEEE Transactions on Automatic Control*, 67(8):4013–4028, 2022.
- [35] P. Blondel, R. Postoyan, S. Raël, S. Benjamin, and P. Desprez. Nonlinear circle-criterion observer design for an electrochemical battery model. *IEEE Transactions on Control Systems Technology*, 27(2):889–897, 2019.
- [36] N. Boizot, E. Busvelle, and J.-P. Gauthier. An adaptive high-gain observer for nonlinear systems. *Automatica*, 46(9):1483–1488, 2010.
- [37] J. Bona, S. Sun, and B. Zhang. A nonhomogeneous boundary-value problem for the korteweg–de vries equation posed on a finite domain. *Communications in Partial Differential Equations*, 28(7-8):1391–1436, 2003.
- [38] S. Bonnabel and J.-J. Slotine. A contraction theory-based analysis of the stability of the deterministic extended Kalman filter. *IEEE Transactions on Automatic Control*, 60(2):565–569, 2015.
- [39] G. Bornard, N. Couenne, and F. Celle. Regularly persistent observers for bilinear systems. In *New trends in nonlinear control theory*, pages 130–140. Springer, 1989.
- [40] H. Brezis. *Functional analysis, Sobolev spaces and partial differential equations*. Springer Science & Business Media, 2010.
- [41] F. Bribiesca-Argomedo and M. Krstic. Backstepping-forwarding control and observation for hyperbolic PDEs with fredholm integrals. *IEEE Transactions on Automatic Control*, 60(8):2145–2160, 2015.
- [42] L. Brivadis, J.-P. A. Gauthier, L. Sacchelli, and U. Serres. Avoiding observability singularities in output feedback bilinear systems. *SIAM Journal on Control and Optimization*, 59(3):1759–1780, 2021.
- [43] K. K. Busawon and P. Kabore. Disturbance attenuation using proportional integral observers. *International Journal of control*, 74(6):618–627, 2001.
- [44] C. I. Byrnes, F. Delli Priscoli, and A. Isidori. Structurally stable output regulation for nonlinear systems. *Automatica*, 33(3):369–385, 1997.
- [45] C. I. Byrnes and A. Isidori. Limit sets, zero dynamics, and internal models in the problem of nonlinear output regulation. *IEEE Transactions on Automatic Control*, 48(10):1712–1723, 2003.

- [46] C. I. Byrnes and A. Isidori. Nonlinear internal models for output regulation. *IEEE Transactions on Automatic Control*, 49(12):2244–2247, 2004.
- [47] C. I. Byrnes, F. D. Priscoli, and A. Isidori. *Output regulation of uncertain nonlinear systems*. Springer Science & Business Media, 1997.
- [48] C. Cai and A. R. Teel. Characterizations of input-to-state stability for hybrid systems. *Systems & Control Letters*, 58(1):47–53, 2009.
- [49] C. Cai, A. R. Teel, and R. Goebel. Smooth Lyapunov functions for hybrid systems-part I: Existence is equivalent to robustness. *IEEE Transactions on Automatic Control*, 52(7):1264–1277, 2007.
- [50] S. Cai, Z. Mao, Z. Wang, M. Yin, and G. Karniadakis. Physics-informed neural networks (pinns) for fluid mechanics: A review. *Acta Mechanica Sinica*, pages 1–12, 2022.
- [51] F. Califano, M. Bin, A. Macchelli, and C. Melchiorri. Stability analysis of nonlinear repetitive control schemes. *IEEE Control Systems Letters*, 2(4):773–778, 2018.
- [52] E. Cerpa. Control of a Korteweg-de Vries equation: a tutorial. *Mathematical Control and Related Fields*, 4(1):45, 2014.
- [53] M. Chapouly. Global controllability of a nonlinear Korteweg–de Vries equation. *Communications in Contemporary Mathematics*, 11(03):495–521, 2009.
- [54] M. Chen. Exponential stabilization of a constrained bilinear system. *Automatica*, 34(8):989–992, 1998.
- [55] Z. Chen and J. Huang. Robust output regulation with nonlinear exosystems. *Automatica*, 41:1447–1454, 2005.
- [56] C. Chicone and Y. Latushkin. *Evolution Semigroups in Dynamical Systems and Differential Equations*. Number 70 in Mathematical Surveys and Monographs. American Mathematical Soc., 1999.
- [57] R. Chill, D. Seifert, and Y. Tomilov. Semi-uniform stability of operator semigroups and energy decay of damped waves. *Philosophical Transactions of the Royal Society A*, 378(2185):20190614, 2020.
- [58] R. Cisneros, M. Pirro, G. Bergna, R. Ortega, G. Ippoliti, and M. Molinas. Global tracking passivity-based PI control of bilinear systems: application to the interleaved boost and modular multilevel converters. *Control Engineering Practice*, 43:109–119, 2015.
- [59] M. Cocetti, S. Tarbouriech, and L. Zaccarian. On dead-zone observers for linear plants. In *American Control Conference*, pages 5138–5143, 2018.
- [60] M. Cocetti, S. Tarbouriech, and L. Zaccarian. High-gain dead-zone observers for linear and nonlinear plants. *IEEE Control Systems Letters*, 3(2):1–6, 2019.
- [61] C. Corduneanu, N. Gheorghiu, and V. Barbu. *Almost Periodic Functions*. Chelsea Publishing Company, 1989.
- [62] J.-M. Coron and A. Hayat. PI controllers for 1-D nonlinear transport equation. *IEEE Transactions on Automatic Control*, 64(11):4570–4582, 2019.

- 
- [63] J.-M. Coron and Q. Lü. Local rapid stabilization for a Korteweg–de Vries equation with a Neumann boundary control on the right. *Journal de Mathématiques Pures et Appliquées*, 102(6):1080–1120, 2014.
- [64] E. Crépeau and J.-M. Coron. Exact boundary controllability of a nonlinear KdV equation with a critical length. *Journal of the European Mathematical Society*, 6:367–398, 2005.
- [65] R. Curtain and H. Zwart. *Introduction to infinite-dimensional systems theory: a state-space approach*, volume 71. Springer, 2020.
- [66] O. Dalin, R. Ofir, E. B. Shalom, A. Ovseevich, F. Bullo, and M. Margaliot. Verifying  $k$ -contraction without computing  $k$ -compounds. *arXiv preprint:2209.01046*, 2022.
- [67] E. Davison. The robust control of a servomechanism problem for linear time-invariant multivariable systems. *IEEE Transactions on Automatic Control*, 21(1):25–34, 1976.
- [68] E. Davison and S. Wang. New results on the controllability and observability of general composite systems. *IEEE Transactions on Automatic Control*, 20(1):123–128, 1975.
- [69] A. Davydov, S. Jafarpour, and F. Bullo. Non-euclidean contraction theory for robust nonlinear stability. *IEEE Transactions on Automatic Control*, 67(12):6667–6681, 2022.
- [70] D. De Palma and G. Indiveri. Output outlier robust state estimation. *International Journal of Adaptive Control and Signal Processing*, 31(4):581–607, 2016.
- [71] J. Deutscher. Robust cooperative output regulation for a network of parabolic pde systems. *IEEE Transactions on Automatic Control*, 67(1):451–459, 2021.
- [72] Y. Dong and J. Huang. Cooperative global output regulation for a class of nonlinear multi-agent systems. *IEEE Transactions on Automatic Control*, 59(5):1348–1354, 2013.
- [73] Y. Ebihara, D. Peaucelle, and D. Arzelier. LMI approach to linear positive system analysis and synthesis. *Systems & Control Letters*, 63:50–56, 2014.
- [74] D. Efimov, T. Raïssi, S. Chebotarev, and A. Zolghadri. Interval state observer for nonlinear time varying systems. *Automatica*, 49(1):200–205, 2013.
- [75] R. Engelking. *General Topology*. Heldermann Verlag, 1989.
- [76] L. Farina and S. Rinaldi. *Positive linear systems: theory and applications*, volume 50. John Wiley & Sons, 2011.
- [77] H. Feng, X.-H. Wu, and B.-Z. Guo. Actuator dynamics compensation in stabilization of abstract linear systems. *arXiv preprint arXiv:2008.11333*, 2020.
- [78] M. Fliess and I. Kupka. A finiteness criterion for nonlinear input–output differential systems. *SIAM Journal on Control and Optimization*, 21(5):721–728, 1983.
- [79] F. Forni and R. Sepulchre. A differential Lyapunov framework for contraction analysis. *IEEE Transactions on Automatic Control*, 59(3):614–628, 2014.
- [80] F. Forni and R. Sepulchre. A dissipativity theorem for p-dominant systems. In *IEEE 56th Conference on Decision and Control*, pages 3467–3472, 2017.

- [81] F. Forni and R. Sepulchre. Differential dissipativity theory for dominance analysis. *IEEE Transactions on Automatic Control*, 64(6):2340–2351, 2019.
- [82] F. Forte, A. Isidori, and L. Marconi. Robust design of internal models by nonlinear regression. *IFAC Proceedings Volumes*, 46(23):283–288, 2013.
- [83] B. A. Francis and W. M. Wonham. The internal model principle for multivariable regulators. *Applied Mathematics and Optimization*, 2(2):170–194, 1975.
- [84] J. Gauthier and I. Kupka. *Deterministic Observation Theory and Applications*. Cambridge University Press, 2001.
- [85] L. Gentili, L. Marconi, and B. Paden. Disturbance rejection in the control of a maglev artificial heart. *Journal of Dynamic Systems, Measurement, and Control*, 130(1):011003, 2008.
- [86] J. Ghosh and B. Paden. Nonlinear repetitive control. *IEEE Transactions on Automatic Control*, 45(5):949–954, 2000.
- [87] M. Giaccagli. *Ph.D. thesis: “Incremental stability and applications for nonlinear control systems”*. PhD thesis, Université Claude Bernard Lyon 1, 2022.
- [88] P. Giesl, S. Hafstein, and C. Kawan. Review on contraction analysis and computation of contraction metrics. *arXiv preprint arXiv:2203.01367*, 2022.
- [89] C. Godsil and G. Royle. *Algebraic graph theory*. Springer, 2001.
- [90] R. Goebel, R. G. Sanfelice, and A. R. Teel. *Hybrid Dynamical Systems: Modeling, Stability, and Robustness*. Princeton University Press, 2012.
- [91] D. Gottlieb and S. Orszag. *Numerical analysis of spectral methods: theory and applications*. SIAM, 1977.
- [92] O. M. Grasselli, A. Isidori, and F. Nicolo. Output regulation of a class of bilinear systems under constant disturbances. *Automatica*, 15(2):189–195, 1979.
- [93] G. Grimm, J. Hatfield, I. Postlethwaite, A. R. Teel, M. C. Turner, and L. Zaccarian. Anti-windup for stable linear systems with input saturation: an LMI-based synthesis. *IEEE Trans. on Autom. Contr.*, 48(9):1509–1525, 2003.
- [94] G. Gu, P. P. Khargonekar, and E. B. Lee. Approximation of infinite-dimensional systems. *IEEE Transactions on Automatic Control*, 34(6):610–618, 1989.
- [95] P. Gutman. Stabilizing controllers for bilinear systems. *IEEE Transactions on Automatic Control*, 26(4):917–922, 1981.
- [96] M. H. Hamid, R. Postoyan, and J. Daafouz. Local observers design for a class of neural mass models. In *European Control Conference*, pages 1830–1835, 2015.
- [97] S. Hara, Y. Yamamoto, T. Omata, and M. Nakano. Repetitive control system: a new type servo system for periodic exogenous signals. *IEEE Transactions on Automatic Control*, 33(7):659–668, 1988.

- 
- [98] W. Heemels, M. Camlibel, and M. Heertjes. Oblique projected dynamical systems and incremental stability under state constraints. *IEEE Control Systems Letters*, 4(4):1060–1065, 2020.
- [99] G. Hillerstrom and J. Sternby. Repetitive control using low order models. In *Proceedings of 1994 American Control Conference-ACC'94*, volume 2, pages 1873–1878. IEEE, 1994.
- [100] M. W. Hirsch. *Differential Topology*. Springer-Verlag, 1994.
- [101] T. Hu, A. R. Teel, and L. Zaccarian. Anti-windup synthesis for linear control systems with input saturation: achieving regional, nonlinear performance. *Automatica*, 44(2):512–519, 2008.
- [102] J. Huang. Asymptotic tracking and disturbance rejection in uncertain nonlinear systems. *IEEE Transactions on Automatic Control*, 40(6):1118–1122, 1995.
- [103] J. Huang and C.-F. Lin. Internal model principle and robust control of nonlinear systems. In *32nd IEEE Conference on Decision and Control*, pages 1501–1506, 1993.
- [104] J. Huang and C.-F. Lin. On a robust nonlinear servomechanism problem. *IEEE Transactions on Automatic Control*, 39(7):1510–1513, 1994.
- [105] J.-P. Humaloja, M. Kurula, and L. Paunonen. Approximate robust output regulation of boundary control systems. *IEEE Transactions on Automatic Control*, 64(6):2210–2223, 2018.
- [106] A. Isidori. *Lectures in feedback design for multivariable systems*. Springer, 2017.
- [107] A. Isidori and C. I. Byrnes. Output regulation of nonlinear systems. *IEEE Transactions on Automatic Control*, 35(2):131–140, 1990.
- [108] A. Isidori, L. Marconi, and L. Praly. Robust design of nonlinear internal models without adaptation. *Automatica*, 48:2409–2419, 2012.
- [109] S. Janny, V. Andrieu, M. Nadri, and C. Wolf. Deep KKL: data-driven output prediction for non-linear systems. In *60th IEEE Conference on Decision and Control*, pages 4376–4381, 2021.
- [110] J. Jouffroy. Some ancestors of contraction analysis. In *44th IEEE Conference on Decision and Control*, pages 5450–5455, 2005.
- [111] R. Kalman. A new approach to linear filtering and prediction problems. *Journal of Basic Engineering*, 82(1):35–45, 1960.
- [112] J. Kasac, B. Novakovic, D. Majetic, and D. Brezak. Passive finite-dimensional repetitive control of robot manipulators. *IEEE Transactions on Control Systems Technology*, 16(3):570–576, 2008.
- [113] H. Khalil. Robustness servomechanism output feedback controllers for a class of feedback linearizable systems. In *Oral presentation at Workshop on nonlinear control systems, St. Louis, Missouri*, 1992.
- [114] H. K. Khalil. On the design of robust servomechanisms for minimum phase nonlinear systems. *International Journal of Robust and Nonlinear Control*, 10(5):339–361, 2000.

- [115] H. K. Khalil and L. Praly. High-gain observers in nonlinear feedback control. *International Journal of Robust and Nonlinear Control*, 24(6):993–1015, 2014.
- [116] A. Krener. Bilinear and nonlinear realizations of input-output maps. *SIAM Journal on Control*, 13(4):827–834, 1975.
- [117] A. Krener. The convergence of the extended Kalman filter. In *Directions in mathematical systems theory and optimization*, pages 173–182. Springer, 2003.
- [118] M. Krichman, E. D. Sontag, and Y. Wang. Input-output-to-state stability. *SIAM Journal on Control and Optimization*, 39(6):1874–1928, 2001.
- [119] M. Krstic. Compensating actuator and sensor dynamics governed by diffusion PDEs. *Systems & Control Letters*, 58(5):372–377, 2009.
- [120] M. Krstic and A. Smyshlyaev. Backstepping boundary control for first-order hyperbolic pdes and application to systems with actuator and sensor delays. *Systems & Control Letters*, 57(9):750–758, 2008.
- [121] V. Kučera and C. De Souza. A necessary and sufficient condition for output feedback stabilizability. *Automatica*, 31(9):1357–1359, 1995.
- [122] E. Kurniawan, Z. Cao, O. Mahendra, and R. Wardoyo. A survey on robust repetitive control and applications. In *IEEE International Conference on Control System, Computing and Engineering*, pages 524–529, 2014.
- [123] J. Kurzweil. On the inversion of Lyapunov’s second theorem on stability of motion. *AMS Translations Series 2*, 24:19–77, 1963.
- [124] Z. Li, Z. Duan, G. Chen, and L. Huang. Consensus of multiagent systems and synchronization of complex networks: A unified viewpoint. *IEEE Transactions on Circuits and Systems I: Regular Papers*, 57(1):213–224, 2009.
- [125] W. Lin. Feedback stabilization of general nonlinear control systems: a passive system approach. *Systems & Control Letters*, 25(1):41–52, 1995.
- [126] C. Liu, Y. Yin, Z. Wang, and F. Liu. Leader-following consensus of heterogeneous bilinear multi-agent systems via bounded input. In *IEEE 13th World Congress on Intelligent Control and Automation*, pages 670–674, 2018.
- [127] H. Logemann, E. Ryan, and S. Townley. Integral control of infinite-dimensional linear systems subject to input saturation. *SIAM journal on control and optimization*, 36(6):1940–1961, 1998.
- [128] H. Logemann, E. P. Ryan, and S. Townley. Integral control of linear systems with actuator nonlinearities: lower bounds for the maximal regulating gain. *IEEE Transactions on Automatic Control*, 44(6):1315–1319, 1999.
- [129] W. Lohmiller and J. E. Slotine. On contraction analysis for non-linear systems. *Automatica*, 34(6):683–696, 1998.
- [130] R. Longchamp. Stable feedback control of bilinear systems. *IEEE Transactions on Automatic Control*, 25(2):302–306, 1980.

- 
- [131] R. W. Longman. Iterative learning control and repetitive control for engineering practice. *International Journal of Control*, 73(10):930–954, 2000.
- [132] F. Luenberger. An introduction to observers. *IEEE Transactions on automatic control*, 16(6):596–602, 1971.
- [133] M. Maggiore and K. M. Passino. A separation principle for a class of non-UCO systems. *IEEE Transactions on Automatic Control*, 48(7):1122–1133, 2003.
- [134] I. Manchester and J. Slotine. Control contraction metrics: convex and intrinsic criteria for nonlinear feedback design. *IEEE Transactions on Automatic Control*, 62(6):3046–3053, 2017.
- [135] L. Marconi and L. Praly. Practical output regulation without high-gain. In *45th IEEE Conference on Decision and Control*, pages 5258–5262, 2006.
- [136] L. Marconi and L. Praly. Uniform practical nonlinear output regulation. *IEEE Transactions on Automatic Control*, 53(5):1184–1202, 2008.
- [137] L. Marconi, L. Praly, and A. Isidori. Output stabilization via nonlinear luenberger observers. *SIAM Journal on Control and Optimization*, 45(6):2277–2298, 2007.
- [138] R. Marino and P. Tomei. Online frequency estimation of periodic signals. In *Mathematical Control Theory I*, pages 257–276. Springer, 2015.
- [139] R. Marino and P. Tomei. Hybrid adaptive multi-sinusoidal disturbance cancellation. *IEEE Transactions on Automatic Control*, 62(8):4023–4030, 2016.
- [140] P. Mattavelli and F. P. Marafao. Repetitive-based control for selective harmonic compensation in active power filters. *IEEE Transactions on Industrial Electronics*, 51(5):1018–1024, 2004.
- [141] F. Mazenc and L. Praly. Adding integrations, saturated controls, and stabilization for feedforward systems. *IEEE Transactions on Automatic Control*, 41(11):1559–1578, 1996.
- [142] A. Mironchenko and C. Prieur. Input-to-state stability of infinite-dimensional systems: recent results and open questions. *SIAM Review*, 62(3):529–614, 2020.
- [143] A. Mironchenko and F. Wirth. Non-coercive Lyapunov functions for infinite-dimensional systems. *Journal of Differential Equations*, 266(11):7038–7072, 2019.
- [144] J. A. Moreno. Asymptotic tracking and disturbance rejection of time-varying signals with a discontinuous pid controller. *Journal of Process Control*, 87:79–90, 2020.
- [145] J. Muldowney. Compound matrices and ordinary differential equations. *Rocky Mountain Journal of Mathematics*, 20(4):857–872, 1990.
- [146] M. U. B. Niazi and K. H. Johansson. Observer design for the state estimation of epidemic processes. In *IEEE 61st Conference on Decision and Control*, pages 4325–4332, 2022.
- [147] T. Omata, S. Hara, and M. Nakano. Nonlinear repetitive control with application to trajectory control of manipulators. *Journal of Robotic systems*, 4(5):631–652, 1987.
- [148] E. Ortiz. The tau method. *SIAM Journal on Numerical Analysis*, 6:480–492, 1969.



- [149] L. Paunonen and S. Pohjolainen. Internal model theory for distributed parameter systems. *SIAM Journal on Control and Optimization*, 48(7):4753–4775, 2010.
- [150] A. Pavlov and L. Marconi. Incremental passivity and output regulation. *Systems & Control Letters*, 57(5):400–409, 2008.
- [151] A. Pavlov, A. Pogromsky, N. van de Wouw, and H. Nijmeijer. Convergent dynamics, a tribute to Boris Pavlovich Demidovich. *Systems & Control Letters*, 52(3-4):257–261, 2004.
- [152] A. Pavlov, N. Van De Wouw, and H. Nijmeijer. *Uniform output regulation of nonlinear systems: a convergent dynamics approach*, volume 205. Springer, 2006.
- [153] V. Q. Phóng. The operator equation  $AX - XB = C$  with unbounded operators  $A$  and  $B$  and related abstract cauchy problems. *Mathematische Zeitschrift*, 208(1):567–588, 1991.
- [154] S. S.-E. Plaza, R. Reyes-Baez, and B. Jayawardhana. Total energy shaping with neural interconnection and damping assignment-passivity based control. In *Learning for Dynamics and Control Conference*, pages 520–531. PMLR, 2022.
- [155] S. Pohjolainen. Robust multivariable PI-controller for infinite dimensional systems. *IEEE Transactions on Automatic Control*, 27(1):17–30, 1982.
- [156] F. Poulain and L. Praly. Robust asymptotic stabilization of nonlinear systems by state feedback. *IFAC Proceedings Volumes*, 43(14):653–658, 2010.
- [157] L. Praly. Observers to the aid of “strictification” of lyapunov functions. *Systems & Control Letters*, 134:104510, 2019.
- [158] L. Praly, R. Ortega, and G. Kaliora. Stabilization of nonlinear systems via forwarding mod  $\{L_g V\}$ . *IEEE Transactions on Automatic Control*, 46(9):1461–1466, 2001.
- [159] L. Praly and Y. Wang. Stabilization in spite of matched unmodeled dynamics and an equivalent definition of input-to-state stability. *Mathematics of Control, Signals and Systems*, 9(1):1–33, 1996.
- [160] C. Prieur and A. R. Teel. Uniting local and global output feedback controllers. *IEEE Transactions on Automatic Control*, 56(7):1636–1649, 2011.
- [161] F. D. Priscoli. Robust tracking for polynomial plants. In *European Control Conference*, pages 369–373, 1993.
- [162] F. D. Priscoli. Output regulation with nonlinear internal models. *Systems & Control Letters*, 53(3-4):177–185, 2004.
- [163] Z. Qu. Robust control of nonlinear uncertain systems under generalized matching conditions. *Automatica*, 29(4):985–998, 1993.
- [164] M. Raissi, P. Perdikaris, and G. Karniadakis. Physics-informed neural networks: a deep learning framework for solving forward and inverse problems involving nonlinear partial differential equations. *Journal of Computational physics*, 378:686–707, 2019.
- [165] R. Rajamani. Observers for Lipschitz nonlinear systems. *IEEE Transactions on Automatic Control*, 43(3):397–401, March 1998.

- 
- [166] L. d. C. Ramos, F. Di Meglio, V. Morgenthaler, L. F. F. da Silva, and P. Bernard. Numerical design of luenberger observers for nonlinear systems. In *59th IEEE Conference on Decision and Control*, pages 5435–5442, 2020.
- [167] A. Rantzer. Distributed control of positive systems. In *50th IEEE Conf. on Decision and Control and European Control Conf.*, pages 6608–6611, 2011.
- [168] C. Rao, J. Rawlings, and D. Mayne. Constrained state estimation for nonlinear discrete-time systems: stability and moving horizon approximations. *IEEE Transactions on Automatic Control*, 48(2):246–258, 2003.
- [169] J. N. Reddy. *Introduction to the finite element method*. McGraw-Hill Education, 2019.
- [170] K. Reif, F. Sonnemann, and R. Unbehauen. An EKF-based nonlinear observer with a prescribed degree of stability. *Automatica*, 34(9):1119–1123, 1998.
- [171] J. Reinders, B. Hunnekens, F. Heck, T. Oomen, and N. van de Wouw. Adaptive control for mechanical ventilation for improved pressure support. *IEEE Transactions on Control Systems Technology*, 29(1):180–193, 2020.
- [172] P. Riedinger and J. Daafouz. Harmonic pole placement. In *2022 IEEE 61st Conference on Decision and Control (CDC)*, pages 5505–5510. IEEE, 2022.
- [173] B. G. Romanchuk. Some comments on anti-windup synthesis using LMIs. *International Journal of Robust and Nonlinear Control*, 9(10):717–734, 1999.
- [174] B. S. Rüffer, N. Van De Wouw, and M. Mueller. Convergent systems vs. incremental stability. *Systems & Control Letters*, 62(3):277–285, 2013.
- [175] L. Sacchelli, L. Brivadis, V. Andrieu, U. Serres, and J.-P. Gauthier. Dynamic output feedback stabilization of non-uniformly observable dissipative systems. *IFAC-PapersOnLine*, 53(2):4923–4928, 2020.
- [176] T. Sakai. *Riemannian geometry*, volume 149. American Mathematical Soc., 1996.
- [177] R. Sanfelice and L. Praly. Convergence of nonlinear observers on  $\mathbb{R}^n$  with a Riemannian metric (Part I). *IEEE Transactions on Automatic Control*, 57(7):1709–1722, 2011.
- [178] G. Scarcitti and A. Astolfi. Model reduction of neutral linear and nonlinear time-invariant time-delay systems with discrete and distributed delays. *IEEE Transactions on Automatic Control*, 61(6):1438–1451, 2015.
- [179] L. Scardovi and R. Sepulchre. Synchronization in networks of identical linear systems. In *47th IEEE Conference on Decision and Control*, pages 546–551, 2008.
- [180] R. Sepulchre, M. Jankovic, and P. V. Kokotovic. *Constructive nonlinear control*. Springer Science & Business Media, 2012.
- [181] M. M. Seron, J. H. Braslavsky, and G. C. Goodwin. *Fundamental Limitations in Filtering and Control*. Springer, 1997.
- [182] A. Serrani and A. Isidori. Global robust output regulation for a class of nonlinear systems. *Systems & Control Letters*, 39(2):133–139, 2000.

- [183] A. Serrani, A. Isidori, and L. Marconi. Semi-global nonlinear output regulation with adaptive internal model. *IEEE Transactions on Automatic Control*, 46(8):1178–1194, 2001.
- [184] H. Shim and D. Liberzon. Nonlinear observers robust to measurement disturbances in an ISS sense. *IEEE Transactions on Automatic Control*, 61(1):48–61, 2016.
- [185] H. Shim, J. H. Seo, and A. Teel. Nonlinear observer design via passivation of error dynamics. *Automatica*, 39(5):885–892, 2003.
- [186] J. Simpson-Porco and F. Bullo. Contraction theory on Riemannian manifolds. *Systems & Control Letters*, 65:74–80, 2014.
- [187] J. E. Slotine and W. Wang. A study of synchronization and group cooperation using partial contraction theory. In *Cooperative control*, pages 207–228. Springer, 2005.
- [188] Y. Song, Y. Wang, J. Holloway, and M. Krstic. Time-varying feedback for regulation of normal-form nonlinear systems in prescribed finite time. *Automatica*, 83:243–251, 2017.
- [189] E. Sontag. An algebraic approach to bounded controllability of linear systems. *International Journal of Control*, 39(1):181–188, 1984.
- [190] E. Sontag. Input to state stability: basic concepts and results. In *Nonlinear and optimal control theory*, pages 163–220. Springer, 2008.
- [191] E. Sontag. Contractive systems with inputs. In *Perspectives in mathematical system theory, control, and signal processing*, pages 217–228. Springer, 2010.
- [192] M. Steinbuch. Repetitive control for systems with uncertain period-time. *Automatica*, 38(12):2103–2109, 2002.
- [193] Y. Su. Semi-global output feedback cooperative control for nonlinear multi-agent systems via internal model approach. *Automatica*, 103:200–207, 2019.
- [194] Y. Su and J. Huang. Cooperative output regulation of linear multi-agent systems. *IEEE Transactions on Automatic Control*, 57(4):1062–1066, 2011.
- [195] S. Tarbouriech, G. Garcia, J. M. Gomes da Silva Jr, and I. Queinnec. *Stability and stabilization of linear systems with saturating actuators*. Springer, 2011.
- [196] A. Teel and L. Praly. Global stabilizability and observability imply semi-global stabilizability by output feedback. *Systems & Control Letters*, 22(5):313–325, 1994.
- [197] A. R. Teel. Global stabilization and restricted tracking for multiple integrators with bounded controls. *Systems & Control Letters*, 18(3):165–171, 1992.
- [198] A. R. Teel. Further variants of the Astolfi/Marconi high-gain observer. In *American Control Conference*, pages 993–998, 2016.
- [199] A. Terrand-Jeanne, V. Andrieu, V. D. S. Martins, and C.-Z. Xu. Adding integral action for open-loop exponentially stable semigroups and application to boundary control of pde systems. *IEEE Transactions on Automatic Control*, 2019.
- [200] E. S. Tognetti, T. R. Calliero, and M. Jungers. Output feedback control for bilinear systems: a polytopic approach. *IFAC-PapersOnLine*, 52(28):58–63, 2019.

- [201] M. Tomizuka, T.-C. Tsao, and K.-K. Chew. Analysis and synthesis of discrete-time repetitive controllers. *Journal of Dynamic Systems, Measurements, and Control*, page 353, 1989.
- [202] C. Tréangle, M. Farza, and M. M'Saad. Filtered high gain observer for a class of uncertain nonlinear systems with sampled outputs. *Automatica*, 101:197–206, 2019.
- [203] M. Tucsnak and G. Weiss. *Observation and control for operator semigroups*. Springer, 2009.
- [204] V. Ugrinovskii. Gain-scheduled synchronization of parameter varying systems via relative  $h_\infty$  consensus with application to synchronization of uncertain bilinear systems. *Automatica*, 50(11):2880–2887, 2014.
- [205] V. Utkin. On convergence time and disturbance rejection of super-twisting control. *IEEE Transactions on Automatic Control*, 58(8), 2013.
- [206] N. Vanspranghe and L. Brivadis. Output regulation of infinite-dimensional nonlinear systems: a forwarding approach for contraction semigroups. *arXiv preprint arXiv:2201.10146*, 2022.
- [207] C. M. Verrelli. A larger family of nonlinear systems for the repetitive learning control. *Automatica*, 71:38–43, 2016.
- [208] C. M. Verrelli and P. Tomei. Adaptive learning control for nonlinear systems: A single learning estimation scheme is enough. *Automatica*, 149:110833, 2023.
- [209] C. Vyasarayani, S. Subhash, and T. Kalmár-Nagy. Spectral approximations for characteristic roots of delay differential equations. *International Journal of Dynamics and Control*, 2(2):126–132, 2014.
- [210] L. Wang, A. Isidori, Z. Liu, and H. Su. Robust output regulation for invertible nonlinear MIMO systems. *Automatica*, 82:278–286, 2017.
- [211] Y. Wang, F. Gao, and F. J. Doyle III. Survey on iterative learning control, repetitive control, and run-to-run control. *Journal of Process Control*, 19(10):1589–1600, 2009.
- [212] L. Wei, R. McCloy, and J. Bao. Discrete-time contraction-based control of nonlinear systems with parametric uncertainties using neural networks. *Computers & Chemical Engineering*, 166:107962, 2022.
- [213] G. Weiss and M. Häfele. Repetitive control of mimo systems using  $h^\infty$  design. *Automatica*, 35(7):1185–1199, 1999.
- [214] J. C. Willems. Deterministic least squares filtering. *Journal of Econometrics*, 118(1-2):341–373, 2004.
- [215] C. Wu and D. V. Dimarogonas. From partial and horizontal contraction to  $k$ -contraction. *arXiv preprint:2208.14379*, 2022.
- [216] C. Wu, I. Kanevskiy, and M. Margaliot.  $k$ -contraction: Theory and applications. *Automatica*, 136:110048, 2022.
- [217] D. Wu and G. Duan. Further geometric and Lyapunov characterizations of incrementally stable systems on Finsler manifolds. *IEEE Transactions on Automatic Control*, 2021.

- [218] W. Xu, E.-W. Bai, and M. Cho. System identification in the presence of outliers and random noises: a compressed sensing approach. *Automatica*, 50(11):2905–2911, 2014.
- [219] B. Yi, R. Wang, and I. Manchester. Reduced-order nonlinear observers via contraction analysis and convex optimization. *IEEE Transactions on Automatic Control*, 2021.
- [220] M. Zamani and P. Tabuada. Backstepping design for incremental stability. *IEEE Transactions on Automatic Control*, 56(9):2184–2189, 2011.
- [221] A. Zemouche and M. Boutayeb. On LMI conditions to design observers for Lipschitz nonlinear systems. *Automatica*, 49(2):585–591, 2013.

## Published papers by Daniele Astolfi

---

- [D1] V. Andrieu, D. Astolfi, and P. Bernard. Mixing sliding mode and linear differentiators for 2nd and 3rd order systems. *IFAC-PapersOnLine*, 53(2):5093–5098, 2020.
- [D2] V. Andrieu, D. Astolfi, and P. Bernard. Observer design via interconnections of second-order mixed sliding-mode/linear differentiators. *International Journal of Robust and Nonlinear Control*, 31:3631–3657, 2021.
- [D3] D. Astolfi. Infinite-dimensional internal models for nonlinear robust output regulation. *Under revision on IEEE Transactions on Automatic Control*.
- [D4] D. Astolfi. Output-feedback repetitive control for minimum-phase nonlinear systems with arbitrarily relative degree. *IFAC-PapersOnLine*, 54(14):464–469, 2021.
- [D5] D. Astolfi, A. Alessandri, and L. Zaccarian. Stubborn iss redesign for nonlinear high-gain observers. *IFAC-PapersOnLine*, 50(1):15422–15427, 2017.
- [D6] D. Astolfi, A. Alessandri, and L. Zaccarian. Stubborn and dead-zone redesign for nonlinear observers and filters. *IEEE Transactions on Automatic Control*, 66(2):667–682, 2021.
- [D7] D. Astolfi, P. Bernard, R. Postoyan, and L. Marconi. Redesign of discrete-time nonlinear observers with state estimate constrained in prescribed convex set. *IFAC-PapersOnLine*, 52(16):454–459, 2019.
- [D8] D. Astolfi, P. Bernard, R. Postoyan, and L. Marconi. Constrained state estimation for nonlinear systems: a redesign approach based on convexity. *IEEE Transactions on Automatic Control*, 67(2):824–839, 2022.
- [D9] D. Astolfi and G. Casadei. Stabilization of nonlinear systems in presence of filtered output via extended high-gain observers. *Automatica*, 110:108594, 2019.
- [D10] D. Astolfi, G. Casadei, and R. Postoyan. Emulation-based semiglobal output regulation of minimum phase nonlinear systems with sampled measurements. In *European Control Conference*, pages 1931–1936, 2018.
- [D11] D. Astolfi, A. Isidori, and L. Marconi. Output regulation via low-power construction. *Feedback Stabilization of Controlled Dynamical Systems: In Honor of Laurent Praly*, pages 143–165, 2017.
- [D12] D. Astolfi, A. Isidori, L. Marconi, and L. Praly. Nonlinear output regulation by post-processing internal model for multi-input multi-output systems. *IFAC Proceedings Volumes*, 46(23):295–300, 2013.
- [D13] D. Astolfi, M. Jungers, and L. Zaccarian. Output injection filtering redesign in high-gain observers. In *European Control Conference*, pages 1957–1962, 2018.

- [D14] D. Astolfi and L. Marconi. A high-gain nonlinear observer with limited gain power. *IEEE Transactions on Automatic Control*, 60(11):3059–3064, 2015.
- [D15] D. Astolfi, L. Marconi, L. Praly, and A. Teel. Sensitivity to high-frequency measurement noise of nonlinear high-gain observers. *IFAC-PapersOnLine*, 49(18):862–866, 2016.
- [D16] D. Astolfi, L. Marconi, L. Praly, and A. R. Teel. Low-power peaking-free high-gain observers. *Automatica*, 98:169–179, 2018.
- [D17] D. Astolfi, L. Marconi, and A. Teel. Low-power peaking-free high-gain observers for nonlinear systems. In *European Control Conference*, pages 1424–1429, 2016.
- [D18] D. Astolfi, S. Marx, V. Andrieu, and C. Prieur. Global exponential set-point regulation for linear operator semigroups with input saturation. In *IEEE 61st Conference on Decision and Control*, pages 7358–7363, 2022.
- [D19] D. Astolfi, S. Marx, and N. van de Wouw. Repetitive control design based on forwarding for nonlinear minimum-phase systems. *Automatica*, 129:109671, 2021.
- [D20] D. Astolfi and C. Possieri. Design of local observers for autonomous nonlinear systems not in observability canonical form. *Automatica*, 103:443–449, 2019.
- [D21] D. Astolfi, R. Postoyan, and D. Nešić. Uniting local and global observers for the state estimation of nonlinear continuous-time systems. In *IEEE 56th Annual Conference on Decision and Control*, pages 3039–3044, 2017.
- [D22] D. Astolfi, R. Postoyan, and D. Nešić. Uniting observers. *IEEE Transactions on Automatic Control*, 65(7):2867–2882, 2020.
- [D23] D. Astolfi, R. Postoyan, and N. van de Wouw. Emulation-based output regulation of linear networked control systems subject to scheduling and uncertain transmission intervals. *IFAC-PapersOnLine*, 52(16):526–531, 2019.
- [D24] D. Astolfi and L. Praly. Output feedback stabilization for siso nonlinear systems with an observer in the original coordinates. In *52nd IEEE Conference on Decision and Control*, pages 5927–5932, 2013.
- [D25] D. Astolfi and L. Praly. Integral action in output feedback for multi-input multi-output nonlinear systems. *IEEE Transactions on Automatic Control*, 62(4):1559–1574, 2017.
- [D26] D. Astolfi, L. Praly, and L. Marconi. Approximate regulation for nonlinear systems in presence of periodic disturbances. In *54th IEEE Conference on Decision and Control*, pages 7665–7670, 2015.
- [D27] D. Astolfi, L. Praly, and L. Marconi. Francis-wonham nonlinear viewpoint in output regulation of minimum phase systems. *IFAC-PapersOnLine*, 52(16):532–537, 2019.
- [D28] D. Astolfi, L. Praly, and L. Marconi. Harmonic internal models for structurally robust periodic output regulation. *Systems & Control Letters*, 161:105154, 2022.
- [D29] D. Astolfi, L. Praly, and L. Marconi. Nonlinear robust periodic output regulation of minimum phase systems. *Mathematics of Control, Signals, and Systems*, 34(1):129–184, 2022.

- [D30] D. Astolfi, L. Zaccarian, and M. Jungers. On the use of low-pass filters in high-gain observers. *Systems & Control Letters*, 148:104856, 2021.
- [D31] M. Bajodek and D. Astolfi. Comparison between different continuous-time realizations based on the tau method of a nonlinear repetitive control scheme. In *IEEE 62st Conference on Decision and Control (under review)*, 2023.
- [D32] I. Balogoun, S. Marx, and D. Astolfi. Iss-lyapunov strictification via observer design and integral action control for a korteweg-de-vries equation. *SIAM Journal on Control and Optimization*. preprint *arXiv:2107.09541*, 2023.
- [D33] G. Beneux, D. Astolfi, P. Riedinger, J. Daafouz, and L. Grimaud. Integral action for uncertain switched affine systems with application to dc/dc converters. In *European Control Conference*, pages 795–800, 2018.
- [D34] P. Bernard, V. Andrieu, and D. Astolfi. Observer design for continuous-time dynamical systems. *Annual Reviews in Control*, 53(2):224–248, 2022.
- [D35] M. Bin, D. Astolfi, and L. Marconi. Robust internal models are linear. *Prov. accepted on Automatica*.
- [D36] M. Bin, D. Astolfi, and L. Marconi. Robust internal model design by nonlinear regression via low-power high-gain observers. In *IEEE 55th Conference on Decision and Control*, pages 4740–4745, 2016.
- [D37] M. Bin, D. Astolfi, and L. Marconi. About robustness of control systems embedding an internal model. *IEEE Transactions on Automatic Control*, 68(3):1306–1320, 2023.
- [D38] M. Bin, D. Astolfi, L. Marconi, and L. Praly. About robustness of internal model-based control for linear and nonlinear systems. In *IEEE Conference on Decision and Control*, pages 5397–5402, 2018.
- [D39] G. Casadei and D. Astolfi. Multipattern output consensus in networks of heterogeneous nonlinear agents with uncertain leader: A nonlinear regression approach. *IEEE Transactions on Automatic Control*, 63(8):2581–2587, 2017.
- [D40] G. Casadei, D. Astolfi, A. Alessandri, and L. Zaccarian. Synchronization in networks of identical nonlinear systems via dynamic dead zones. *IEEE Control Systems Letters*, 3(3):667–672, 2019.
- [D41] G. Casadei, D. Astolfi, A. Alessandri, and L. Zaccarian. Synchronization of interconnected linear systems via dynamic saturation redesign. *IFAC-PapersOnLine*, 52(16):622–627, 2019.
- [D42] M. Giaccagli, V. Andrieu, D. Astolfi, and G. Casadei. Sufficient metric conditions for synchronization of leader-connected homogeneous nonlinear multi-agent systems. *IFAC-PapersOnLine*, 54(14):412–417, 2021.
- [D43] M. Giaccagli, V. Andrieu, S. Tarbouriech, and D. Astolfi. LMI conditions for contraction, integral action and output feedback stabilization for a class of nonlinear systems. *Automatica*.



- [D44] M. Giaccagli, V. Andrieu, S. Tarbouriech, and D. Astolfi. Infinite gain margin, contraction and optimality: an LMI-based design. *European Journal of Control*, page 100685, 2022.
- [D45] M. Giaccagli, D. Astolfi, and V. Andrieu. Further results on incremental input-to-state stability based on contraction-metric analysis. In *IEEE 62st Conference on Decision and Control (under review)*, 2023.
- [D46] M. Giaccagli, D. Astolfi, V. Andrieu, and L. Marconi. Incremental stabilization of cascade nonlinear systems and harmonic regulation: a forwarding-based design. *Prov. accepted on IEEE Transactions on Automatic Control*.
- [D47] M. Giaccagli, D. Astolfi, V. Andrieu, and L. Marconi. Sufficient conditions for output reference tracking for nonlinear systems: a contractive approach. In *59th IEEE Conference on Decision and Control*, pages 4580–4585, 2020.
- [D48] M. Giaccagli, D. Astolfi, V. Andrieu, and L. Marconi. Sufficient conditions for global integral action via incremental forwarding for input-affine nonlinear systems. *IEEE Transactions on Automatic Control*, 67(12):6537–6551, 2022.
- [D49] M. Giaccagli, S. Zoboli, D. Astolfi, V. Andrieu, and G. Casadei. Synchronization in networks of nonlinear systems: Contraction analysis via riemannian metrics and deep-learning for feedback estimation. *Under revision on IEEE Transactions on Automatic Control*.
- [D50] O. Koçan, D. Astolfi, C. Poussot-Vassal, and A. Manecy. Supervised output regulation via iterative learning control for rejecting unknown periodic disturbances. *IFAC-PapersOnLine*, 53(2):1427–1432, 2020.
- [D51] S. Marx, D. Astolfi, and V. Andrieu. Forwarding-lyapunov design for the stabilization of coupled odes and exponentially stable pdes. In *European Control Conference*, pages 339–344, 2022.
- [D52] S. Marx, L. Brivadis, and D. Astolfi. Forwarding design for stabilization of a coupled transport equation-ode with a cone-bounded input nonlinearity. In *59th IEEE Conference on Decision and Control*, pages 640–645, 2020.
- [D53] S. Marx, L. Brivadis, and D. Astolfi. Forwarding techniques for the global stabilization of dissipative infinite-dimensional systems coupled with an ode. *Mathematics of Control, Signals, and Systems*, 33(4):755–774, 2021.
- [D54] E. Morfin, D. Astolfi, and V. Andrieu. Adaptive low-power high-gain observers for lower-triangular systems with input-dependent lipschitz constant. *IFAC-PapersOnLine*, 53(2):4904–4909, 2020.
- [D55] J. Peralez, M. Nadri, and D. Astolfi. Neural network-based kkl observer for nonlinear discrete-time systems. In *IEEE 61st Conference on Decision and Control*, pages 2105–2110, 2022.
- [D56] E. Petri, R. Postoyan, D. Astolfi, D. Nešić, and V. Andrieu. Hybrid multi-observer for improving estimation performance. *Under revision on IEEE Transactions on Automatic Control*.

- [D57] E. Petri, R. Postoyan, D. Astolfi, D. Nešić, and V. Andrieu. Towards improving the estimation performance of a given nonlinear observer: a multi-observer approach. In *IEEE 61st Conference on Decision and Control*, pages 583–590, 2022.
- [D58] E. Petri, R. Postoyan, D. Astolfi, D. Nešić, and M. Heemels. Decentralized event-triggered estimation of nonlinear systems. *Under revision on Automatica*.
- [D59] E. Petri, R. Postoyan, D. Astolfi, D. Nešić, and W. M. H. Heemels. Event-triggered observer design for linear systems. In *60th IEEE Conference on Decision and Control*, pages 546–551, 2021.
- [D60] E. Petri, T. Reynaudo, R. Postoyan, D. Astolfi, D. Nešić, and S. Raël. State estimation of an electrochemical lithium-ion battery model: improved observer performance by hybrid redesign. In *European Control Conference*, 2023.
- [D61] J. Reinders, M. Giaccagli, B. Hunnekens, D. Astolfi, T. Oomen, and N. van De Wouw. Repetitive control for lur'e-type systems: application to mechanical ventilation. *IEEE Transactions on Control Systems Technology*, 2023.
- [D62] T. Simon, M. Giaccagli, J.-F. Tréguët, D. Astolfi, V. Andrieu, X. Lin-Shi, and H. Morel. Robust output set-point tracking for a power flow controller via forwarding design. In *60th IEEE Conference on Decision and Control*, pages 6385–6390, 2021.
- [D63] T. Simon, M. Giaccagli, J.-F. Tréguët, D. Astolfi, V. Andrieu, H. Morel, and X. Lin-Shi. Robust regulation of a power flow controller via nonlinear integral action. *IEEE Transactions on Control Systems Technology*, 2023.
- [D64] S. Tarbouriech, A. Alessandri, D. Astolfi, and L. Zaccarian. Lmi-based stubborn and dead-zone redesign in linear dynamic output feedback. *IEEE Control Systems Letters*, 7:187–192, 2022.
- [D65] L. Wang, D. Astolfi, L. Marconi, and H. Su. High-gain observers with limited gain power for systems with observability canonical form. *Automatica*, 75:16–23, 2017.
- [D66] L. Wang, D. Astolfi, H. Su, L. Marconi, and A. Isidori. Output stabilization for a class of nonlinear systems via high-gain observer with limited gain power. *IFAC-PapersOnLine*, 48(11):730–735, 2015.
- [D67] B. Zitte, B. Hamroun, D. Astolfi, and F. Couenne. Robust control of a class of bilinear systems by forwarding: Application to counter current heat exchanger. *IFAC-PapersOnLine*, 53(2):11515–11520, 2020.
- [D68] S. Zoboli, V. Andrieu, D. Astolfi, G. Casadei, J. S. Dibangoye, and M. Nadri. Reinforcement learning policies with local LQR guarantees for nonlinear discrete-time systems. In *60th IEEE Conference on Decision and Control*, pages 2258–2263, 2021.
- [D69] S. Zoboli, D. Astolfi, and V. Andrieu. Total stability and integral action for discrete-time nonlinear systems. *Automatica*.
- [D70] S. Zoboli, A. Cecilia, U. Serres, D. Astolfi, and V. Andrieu. LMI conditions for k-contraction analysis: a step towards design. In *IEEE 62st Conference on Decision and Control (under review)*, 2023.