



HAL
open science

Contribution on the study of complex dynamical systems: applications in population dynamics

Ihab Haidar

► **To cite this version:**

Ihab Haidar. Contribution on the study of complex dynamical systems: applications in population dynamics. Automatic Control Engineering. CY Cergy Paris Université, 2023. tel-04165090

HAL Id: tel-04165090

<https://hal.science/tel-04165090>

Submitted on 18 Jul 2023

HAL is a multi-disciplinary open access archive for the deposit and dissemination of scientific research documents, whether they are published or not. The documents may come from teaching and research institutions in France or abroad, or from public or private research centers.

L'archive ouverte pluridisciplinaire **HAL**, est destinée au dépôt et à la diffusion de documents scientifiques de niveau recherche, publiés ou non, émanant des établissements d'enseignement et de recherche français ou étrangers, des laboratoires publics ou privés.

ENSEA & CY Cergy Paris Université

HABILITATION À DIRIGER DES RECHERCHES

Specialité : génie informatique, automatique et traitement du signal

Contribution on the study of complex dynamical systems: applications in population dynamics

Ihab HAIDAR

Soutenue le 12 Mai 2023 devant le jury composé de:

Garant:

Jean-Pierre BARBOT

Professeur à ENSEA & École Centrale de Nantes

Rapporteurs:

Jamal DAAFOUZ

Professeur à Université de Lorraine

Isabelle QUEINNEC

Directrice de recherche, CNRS, Université de Toulouse

Fabian WIRTH

Professeur à Université de Passau

Examineurs:

Christophe PRIEUR

Directeur de recherche, CNRS, Université Grenoble Alpes

Emmanuel TRÉLAT

Professeur à Sorbonne Université

Référente:

Mai-Khuong N. VERGER

Professeur à CY Cergy Paris Université

Contents

Acknowledgments	5
General introduction	7
Collaborations	13
List of publications	17
Abbreviations	21
Notations	23
1 Lyapunov stability characterisation for infinite-dimensional switching systems	25
1.1 Abstract	25
1.2 Introduction	26
1.3 Notations and definitions	26
1.4 Converse Lyapunov theorems for infinite-dimensional switching systems	29
1.4.1 Coercive vs non-coercive Lyapunov functionals	29
1.4.2 Lyapunov functional for exponential stability characterisations	32
1.4.3 Application: a link between exponential and input-to-state stability	34
1.4.4 Application: predictor-based sampled data exponential stabilization	34
1.4.5 Application: retarded systems with uncertain delay	37
1.5 Converse Lyapunov theorems for switching retarded linear systems	38
1.5.1 Application: robustness with respect to perturbations	39
1.5.2 Application: stability of interconnected switching retarded linear systems	41
1.6 Converse Lyapunov theorems for nonlinear switching retarded systems	41
1.6.1 Input-to-state stability characterisation theorems	43
1.6.2 Asymptotic and exponential stability characterisation theorems	44
1.6.3 Application: a link between exponential and input-to-state stability	45
1.6.4 Application: stability by first order approximation	46
2 Input-output linearisation and relaxation results for time-delay control systems	49
2.1 Abstract	49
2.2 Introduction	50

2.3	Input-output linearisation of time-varying delay systems	50
2.3.1	Notations, definitions and problem statement	51
2.3.2	Input-output linearisation theorem	53
2.3.3	Application: stabilization of time-varying delay systems	55
2.4	Viable trajectories for nonconvex delay differential inclusions	57
2.4.1	Definitions and assumptions in use	59
2.4.2	Main results	59
2.4.3	Applicability of the obtained results	61
3	Application in population dynamics	65
3.1	Abstract	65
3.2	Introduction	66
3.3	Mathematical models and problems related to microbial dynamics in bioreactors	66
3.3.1	Microbial dynamics within interconnected bioreactors	67
3.3.2	Observers for batch processes with Haldane growth function	72
3.3.3	Optimal control of an electro-fermentation process within a batch Culture	75
3.4	Analysis and control of time-delay systems for neurosciences applications	79
3.4.1	Firing rate model for basal ganglia oscillations	79
3.4.2	The role of external excitatory nuclei on basal ganglia oscillations	80
3.4.3	Closed-loop deep brain stimulation	82
3.5	Urban pigeon population management: viability theory approach	83
3.5.1	Mathematical model	84
3.5.2	Management of the pigeon population as a viability problem	84
3.5.3	Numerical computation of viability kernels	85
4	Perspectives	87
4.1	Relaxed converse Lyapunov theorems for switching retarded systems	87
4.2	Singularly perturbed switching linear systems	88
4.3	Control and observation of switching systems: applications in electro-fermentation	90
	Bibliographie	92

Acknowledgments

I would like to express my sincere gratitude to Jamal Daafouz, Isabelle Queinnec, and Fabian Wirth for giving me the honor of reviewing this document. I am also thankful to the committee members, Christophe Prieur and Emmanuel Trélat, for agreeing to evaluate my research activities, and to Mai-Khuong N. Verger for agreeing to be my referent at CY University. Special thanks go to Jean-Pierre Barbot for his generous guidance and support.

I am grateful for all the researchers I had the privilege to work with, as without their contributions this project would not have come to fruition. In particular, I would like to thank Antoine Chaillet, Yacine Chitour, Jean-Pierre Barbot, H el ene Frankowska, Paolo Mason, Pierdomenico Pepe, Alain Rapaport and Mario Sigalotti.

I am thankful to ENSEA for providing me a conducive academic environment as well as a financial support for a part of my research activities. I am also grateful to my colleagues at QUARTZ lab, including Woihida Aggoune, Alaa Alali, and Florentina Nicolau, for providing a supportive research environment. Special thanks go to the administrative staff members, especially to Carole Van Der Eecken and Achour Ouslimani, for their assistance in preparing my HDR day. Additionally, I want to extend my appreciation to the administrative staff at CY University for their assistance and the facilities they provided during the administrative procedures.

I want to acknowledge the absolute support and encouragement of my lifelong friends (Hassoun, Hanhoun, Abou Shreif, Ali-Roma, Hassan and Samer) in the *Purciens Club*.

I am also grateful to the *Calmeta CrossFit team* for improving in me the values of endurance and competition.

I cannot express enough gratitude to my family and loved ones (my parents, Souheir, Bassem, Rawad, Samah, Rabah, Suzi and Chema) who have been a constant source of support throughout this challenging journey. I want to give special thanks to my little butterfly Yara, my leading man Chadi, and my eternal love Waed.

Completing this Habilitation thesis is a significant accomplishment for me, and I am deeply thankful to everyone who has been a part of my journey. Your support, guidance, and collaboration have been invaluable, and I want to express my heartfelt appreciation to each and every one of you.

Thank you.

Ihab Haidar, ENSEA, Laboratoire Quartz, Cergy-Pontoise, France
ihab.haidar@ensa.fr

General introduction

A wide variety of natural and engineering systems can be modeled by ordinary differential equations (ODEs). The dynamic of microorganisms in bioreactors, the progression of chemical reactions, the propagation of signals along neural axons, and many other physical and biological phenomena can be represented by ODEs [168]. However, in order to take into account some complex characters encountered in the behavior of these systems, more suitable classes of dynamical systems are needed. This can be encountered, for example, when dealing with multi-modal systems where their behaviors are the result of commutation between different dynamics [33]. In the literature, these systems are called *switching systems* [117]. Switching systems consist an interesting class of dynamical systems which are intensively studied in the literature. For example, switching systems can be used to model the dynamics of microorganisms in bioreactors which are subject to fluctuating environment [196]. In the steel production framework, switching systems are used to describe the change of dynamics in the last phase of the rolling process in a hot strip mill [127]. The switching system approach has also been applied to the control system design for some physical systems for which switching control method can achieve a better control performance rather than that of a single controller [175]. Systems relating the instantaneous derivative of the state to the history of the current state called *time-delay systems* [88] is another complexity which is usually needed in order to be more realistic. For example, in the study of some neurological disease like Parkinson's disease, the delay of electrical connections between neurons cannot be neglected to describe some pathological oscillations [147]. Many other processes include delays in their inner dynamics (see, e.g., [112, 150, 163] for different examples from biology, chemistry, population dynamics, as well as in engineering sciences). In addition, actuators, sensors, field networks that are involved in feedback loops usually introduce delays (see, e.g., [193]).

A typical problem when dealing with a switching system concerns its uniform stability. In fact, the question is whether such a dynamical system, whose evolution is influenced by a time-dependent signal, is uniformly stable with respect to all signals in a given fixed class. This problem has motivated an interesting branch in the literature of control theory (see, e.g., [3, 15, 117, 118, 174, 180] and references therein). The existence of a *common Lyapunov function*, i.e., a Lyapunov function which decays uniformly along the trajectories of each individual subsystem, consists a sufficient condition for various uniform stability notions [117]. The necessity question about the existence of common Lyapunov functions which are uniformly stable has been also studied by means of the so called *converse Lyapunov theorems*. Converse Lyapunov theorems for the global asymptotic stability are given in [32, 129, 192] for finite-dimensional systems,

in [71, 91, 140] for infinite-dimensional systems, and in [76, 77, 84] for switching retarded systems. These converse like theorems are of special interest in the literature of control theory. For example, they can be helpful for the stability analysis of interconnected systems [77]. They are also a key for characterising an important stability notion called *input-to-state stability* (ISS), introduced by E. Sontag in [185] for systems described by finite-dimensional ODEs. The ISS notion is further generalised for switching systems in [128]. In the absence of a common Lyapunov function, other interesting issues concerning the stability of switching systems rely on the *multiple Lyapunov functions* approach [19]. Instead of considering arbitrary switchings, one restricts the class of admissible signals, by imposing, for instance, a dwell time or average dwell time constraint [94, 102, 165] or persistent excitation [26]. Also the concept of switched Lyapunov function has been introduced in the literature (see, e.g., [28] for switching discrete-time systems).

Time-delay systems belong to the class of functional differential equations which are infinite-dimensional. Problems concerning stability properties of such systems have received a significant interest since the fifties (see, e.g., [20, 41, 106, 134, 158, 166, 173]). Two principal approaches, allowing to give sufficient conditions for the stability of such systems, have been developed in the literature (see e.g. [112, 88, 150, 52]): the Lyapunov–Krasovskii approach which consists in finding a positive functional on the Banach space of the history state that decays along the trajectories of the considered systems [113] and the Lyapunov–Razumikhin approach which employs Lyapunov functions instead of Lyapunov functionals [172]. Based on these two approaches, various stability notions, originally built for finite-dimensional systems, have been extended to time-delay systems. For example, the ISS notion has been generalised to time-delay systems using the Lyapunov–Razumikhin approach in [186] and using the Lyapunov–Krasovskii approach in [160] (for more details, see the recent survey [23] on ISS framework for time-delay systems). This ISS framework has been also extended to general infinite dimensional systems as reviewed in [136]. Time-varying delay systems constitute an intriguing class of functional differential equations for which some non-intuitive properties are discussed and analysed in the literature (see, e.g., [74, 116]). For example, in [74] we have studied the Markus–Yamabe instability property [130] in the framework of linear time-varying delay systems: even if for each constant delay $\tau \in [0, \bar{\tau}]$, $\bar{\tau} > 0$, the system is exponentially stable, the stability of the time-varying one is not guaranteed when the delay varies in $[0, \bar{\tau}]$. This result highlights the influence of the time-varying delay on system’s stability or instability. Time-varying delay systems with uncertain delay can be seen as a special class of switching systems. This paradigm has been proposed in [95] where discrete-time delay systems have been transformed into discrete-time delay-free switching systems evolving in a higher-dimensional space. Thus, looking for a delay-dependent (respectively, delay-independent) Lyapunov–Krasovskii functional for the initial system, is equivalent to applying the multiple Lyapunov functions (respectively, common Lyapunov function) approach to the switched systems representation. Continuous-time retarded equations can be similarly interpreted as switching systems in infinite-dimensional Banach spaces, as shown in [76].

This memoir is organised into three chapters and a perspectives chapter:

In Chapter 1 we present the main contributions concerning the stability of switching infinite-dimensional systems. These contributions are briefly represented as follows. We start by considering abstract forward complete dynamical systems evolving in a Banach space, subject to a shift-invariant set of uncertainties. A set of converse theorems characterising different types

of uniform local, semi-global, and global exponential stability, through the existence of non-coercive and coercive Lyapunov functionals proved in [71, 76, 77] is recalled. The importance of the obtained results is underlined through some applications like sampled data control design and some robustness stability properties. These results are also useful to characterise the stability of time-delay systems with uncertain piecewise-constant delay. Indeed, as underlined above, delay systems with uncertain time-varying delay can be transformed to delay-free switching systems evolving in an infinite-dimensional Banach space; then the stability results developed in general Banach space can be used for this class of systems. After that, we focus on systems described by retarded functional differential equations with relaxed regularities on the vector field defining the dynamics as well on the class of switching signals. We characterise various stability notions (input-to-state, asymptotic and exponential stability) by the existence of a common Lyapunov–Krasovskii functional with suitable conditions [84, 85]. An equivalence property showing that uniform input-to-state stability can be equivalently studied through the class of piecewise-constant inputs and piecewise-constant switching signals is also recalled. Thanks to this equivalence property we show how the regularity assumption required on a Lyapunov–Krasovskii functional can be relaxed. The relevancy of the obtained results is shown through different examples and theoretical applications like a first order approximation theorem for nonlinear switching retarded systems. Thanks to these converse theorems, a link between the exponential stability of an unforced switching retarded system and the input-to-state stability property, in the case of measurable switching signals, is also obtained in [85].

In Chapter 2, motivated by problems deriving from population dynamics, we focus on more elaborated properties concerning time-delay systems. The first property concerns the input-output linearisation problem of time-varying delay control systems with affine control. The input-output linearisation approach is an important tool in nonlinear control theory which consists, after the application of a suitable feedback transformation, in finding a direct linear relation between the input and the output of the system. The problem of input-output linearisation is well known for nonlinear control systems without delays. For constant-delay systems, a well constructive algebraic approach is developed in the literature to deal with the input-output linearisation problem as well as with more sophisticated properties like input-to-state and flatness problems (see, e.g., [21]). However, in the case of time-varying delay the problem of input-output linearisation is very hard to deal with for different reasons. The fundamental reason is that the algebraic approach is specific to constant-delay systems and it is not so evident how we can extend it to cover the time-varying delay system's class. Some recent results aim to propose a suitable algebraic approach (see [167]) but the problem is far from being solved. In [79, 78, 80], by adopting the geometric approach developed for finite-dimensional systems, we give some sufficient conditions guarantying the solvability of the input-output linearisation of time-varying delay systems. These conditions, in the case of single-input single-output, are recalled in this chapter. The case of multi-input multi-output case is treated in [148, 149]. The second part of this chapter is devoted around the existence of *viable trajectories* for non-convex delay differential inclusions under state constraints. The viability theory [7] provides adequate mathematical tools to study the condition of existence of solutions for convex differential inclusions which satisfy a predefined state constraint set. When they exist these trajectories are called viable trajectories. When the viability condition fails to be fulfilled on the boundary of the constraint set, viability algorithms providing constructive methods for the computation of viability kernels have been developed in the literature (see, e.g., [48, 178]). These algorithms

are developed for convex and delay-free inclusions. Two steps are needed to extend these numerical methods to delay differential inclusions: adapt the viability algorithms to the case of delay differential inclusions and obtain relaxation theorems under state constraints. The latter point is solved in [43, 44] and exposed in the second part of Chapter 2.

In Chapter 3 we present contributions in mathematical modelling and analysis in three different domains of population dynamics. The first is about microbial dynamics in bioreactors, where the *chemostat* based model is used. The chemostat is the most famous model describing the microbial dynamics in a continuous culture [151, 184]. The importance of this model comes from the fact that with a simple system of finite-dimensional ODEs we can model many interesting phenomena from different fields of applications like pharmaceutical industry, water purification, anaerobic digestion, bioelectricity, and other renewable energy systems [168]. This model has been also used in [63] to model the microbial dynamics of saturated soil by approaching a porous saturated soil by a network of interconnected chemostats with different type of physical interconnections. In this context, some nonintuitive results have been obtained in [87, 170] concerning the role of spatialization in chemostat. These results are briefly recalled in this chapter. A contribution in the domain of observability of microbial dynamics in bioreactors is also shown. The problem of controllability and observability of bioprocesses has attracted many interesting researches (see, e.g., [183, 18, 182, 36, 55, 93, 169, 171]). As for the observability problem, an interesting point concerns the case where microbial dynamics can be inhibited by large concentrations of nutrient, which is the case of many microbial biomasses. In this case, a singular observability problem appears in the chemostat. The problem of observation of singularly observable systems has been widely investigated in the literature with different constructive methods (see, e.g., [12]). Particularly, in the case of the chemostat model, a solution has been proposed in [171]. These methods are very hard to set up in practice. Recently, in [66, 67, 68], we have solved this problem by proposing a simpler approach for planar systems. Another contribution concerns the use of the chemostat to model and analyse an *electro-fermentation* process. A fermentation metabolism refers to anaerobic biochemical reactions performed by microorganisms. This metabolism, which is held with a balanced electron exchange, gives rise to products with given proportionality. Perturbing these electron balances (through the implementation of electrodes in the bioprocess) provokes a switching between different metabolic pathways and therefore to different product's proportionality. The electro-fermentation process consists then to electrochemically control a microbial fermentative metabolism with electrodes [143]. In order to describe this electro-chemical phenomenon, a first mathematical model has been proposed in [72] in collaboration with INRAE (MISTEA and LBE labs). The main objective of the developed model is to supervise the dynamical interplay between the biological and the power electrical part of the electro-fermentation process in order to maintain a maximal productivity for a long duration. By productivity we mean a high-value fermentative product. Based on this model an optimal control problem is formulated in order to maximise the production of one of the fermentative products. The second part of this chapter concerns the analysis of a neural population dynamics describing the evolution of the Parkinson's disease. The Parkinson's disease is a long-term degenerative disorder within the basal ganglia that mainly affects the motor system. This disorder is highly correlated to a pathological synchronisation between two principal neural nuclei, namely the substantia nigra (STN) and the globus pallidus externe (GPe). The deep brain stimulation (DBS) is an efficient surgical technique with positive therapeutic effects which consists in electrically stimulating the

STN [11]. In order to optimise and improve the efficiency of DBS, a closed-loop DBS technique has been proposed in the literature [176]. Starting from a firing rate model [147] which describe the STN-GPe dynamics, in [81] we develop a theoretical closed-loop DBS strategy. Additional analysis concerning the influence of external neural nuclei on the STN-GPe system has been done in [83]. The third contribution presented in this chapter concerns the problem of managing of urban pigeon populations. Urban pigeon populations can reach high densities in cities and cause cohabitation problems with urban citizens. Using some regulation strategies, it is possible to make it reach a density target with respect to given socio-ecological constraints. The mathematical viability theory, which provides a framework to study compatibility between dynamics and state constraints, has been employed in [65] to study the efficiency of certain regulation strategies.

Collaborations

The results presented in this memoir are the fruits of collaborations with different researchers. These results would not have been possible without their contributions, dynamism and patience. I warmly thank them for giving me the opportunity to work with them.

- **Woihida AGGOUNE**, Associate professor at ENSEA (QUARTZ lab), with whom we have developed the results concerning the input-output linearisation and decoupling of time-varying delay systems (Section 2.3).
- **Isabelle ALVAREZ**, Researcher at INRAE (LISC lab), with whom we have developed a model for the management of urban pigeon population and numerically compute the associated viability kernel (Section 3.5).
- **Jean-Pierre BARBOT**, Professor at ENSEA (QUARTZ lab) and École Centrale de Nantes (LS2N lab), with whom we have developed the results concerning the input-output linearisation and decoupling of time-varying delay systems (Section 2.3) and the results concerning the multi-observers approach of non-uniformly observable systems (Section 3.3.2).
- **Antoine CHAILLET**, Professor at CentraleSupélec (L2S lab), with whom we have developed the results concerning the analysis and feedback control of time-delay systems describing the Parkinson's disease (Section 3.4).
- **Yacine CHITOUR**, Professor at Université Paris-Saclay (L2S lab), with whom we have developed the theoretical results concerning the Lyapunov stability characterisation of infinite-dimensional switched systems presented in Section 1.4.
- **Alain RAPAPORT**, Senior Researcher at INRAE (MISTEA, Montpellier), who supervised my PhD thesis and with whom we have developed the results concerning the effects of spatialization on the performances of the chemostat presented in Section 3.3.1, the results concerning the multi-observers approach of non-uniformly observable systems (Section 3.3.2), and the results concerning the use of the chemostat model to describe and analyse an electro-fermentation process (Section 3.3.3).
- **Elie DESMOND-LE QUÉMÉNER**, Junior Researcher at INRAE (LBE, Narbonne), with whom we have developed the results concerning the use of the chemostat model to describe and analyse an electro-fermentation process (Section 3.3.3).

- **Hélène FRANKOWSKA**, Senior Researcher at CNRS (Sorbonne University, IMJ-PRG lab), with whom we have developed the results concerning the existence of viable trajectories for state constrained non-convex delay differential inclusions (Section 2.4).
- **Jérôme HARMAND**, Senior Researcher at INRAE (LBE, Narbonne), with whom we have developed the results concerning the dynamics of the buffered chemostat presented in Section 3.3.1, and the results concerning the use of the chemostat model to describe and analyse an electro-fermentation process (Section 3.3.3).
- **Paolo MASON**, Junior Researcher at CNRS (L2S lab), with whom we have developed the theoretical results concerning the Lyapunov stability characterisation of infinite-dimensional switched systems presented in Section 1.4, and the results concerning the stability of uncertain delay systems (Section 1.5).
- **Florentina NICOLAU**, Associate Professor at ENSEA (QUARTZ lab), with whom we have developed the results concerning the input-output linearisation and decoupling of time-varying delay systems (Section 2.3).
- **Pierdomenico PEPE**, Professor at University of L'Aquila (Department of Information Engineering, Computer Science, and Mathematics), with whom we have developed the results concerning the Lyapunov-Krasovskii characterisation of various type of stabilities for switching retarded systems (Section 1.6).
- **Elena PANTELEY**, Senior Researcher at CNRS (L2S lab), with whom we have developed the results concerning the analysis and feedback control of time-delay systems describing the Parkinson's disease (Section 3.4).
- **William PASILLAS-LÉPINE**, Junior Researcher at CNRS (L2S lab), with whom we have developed the results concerning the analysis and feedback control of time-delay systems describing the Parkinson's disease (Section 3.4).
- **Anne-Caroline PRÉVOT**, Senior Researcher at CNRS (CESCO-MNHN), with whom we have developed a model of managing of urban pigeon population which is subject to socio-ecological constraints (Section 3.5).
- **Suhan SENOVA**, Neurosurgeon (APHP) and Researcher (UPEC), with whom we have developed a control-oriented model in the framework of Parkinson's disease (Section 3.4).
- **Mario SIGALOTTI**, Senior Researcher at INRIA (Sorbonne University), with whom we have developed the theoretical results concerning the Lyapunov stability characterisation of infinite-dimensional switched systems presented in Section 1.4, and the results concerning the stability of uncertain delay systems (Section 1.5).

Other works which are not treated here are given in collaboration with:

- **Nabih FEKI**, Professor at ENIS (LA2MP lab), with whom I co-supervised the thesis of Mariem MAKNI [123, 124, 125].

-
- **Frédérique GÉRARD**, Senior Researcher at INRAE (Eco&Sols, Montpellier), with whom we realised a numerical comparison between interconnected chemostats based model and the multicomponent reactive transport model (MIN3P) in variably saturated porous media [73].
 - **Mariem MAKNI**, PhD student between ENSEA-Quartz and ENIS-LA2MP, that I co-supervised his PhD with Jean-Pierre BRABOT and Franck PLESTAN, with whom we have studied the problem of twin wind turbine and developed new control strategies for the diagnosis and supervision of faulty twin wind turbine [121, 122, 123, 124, 125].
 - **Silviu NICULESCU**, Senior Researcher at CNRS (L2S lab), with whom we have developed the results concerning the quenching phenomenon of time-varying delay differential equations [74].
 - **Franck PLESTAN**, Professor at École Centrale Nantes (LS2N lab), with whom we developed new control strategies for the diagnosis and supervision of faulty twin wind turbine [121, 122, 123, 124, 125].

List of publications

Journal papers

1. Yacine Chitour, [Ihab Haidar](#), Paolo Mason and Mario Sigalotti, *Upper and lower bounds for the maximal Lyapunov exponent of singularly perturbed linear switching systems*, Automatica, 155:111151, 2023.
2. Mariem Makni, [Ihab Haidar](#), Jean-Pierre Barbot and Franc Plestan, *Active Fault-Tolerant Control Based on Sparse Recovery Diagnosis: The Twin Wind Turbines Case*, International Journal of Robust and Nonlinear Control, 2022.
3. [Ihab Haidar](#), Elie Desmond-Le Quéméner, Jean-Pierre Barbot, Jérôme Harmand and Alain Rapaport, *Modeling and Optimal Control of an Electro-Fermentation Process within a Batch Culture*, 10, 535, Processes 2022,
4. Mariem Makni, [Ihab Haidar](#), Jean-Pierre Barbot, Franc Plestan, Nabih Feki, M. Slim Abbes, *Observer-Based Active Fault-Tolerant Control of an Asymmetric Twin Wind Turbine*, 13, 113, Information 2022.
5. [Ihab Haidar](#), Jean-Pierre Barbot and Alain Rapaport, *A multi-observers approach for a class of bidimensional non-uniformly observable systems*, doi: 10.1109/TAC.2022.3142122, IEEE Transactions on Automatic Control, Jan. 2022.
6. [Ihab Haidar](#), Yacine Chitour, Paolo Mason and Mario Sigalotti, *Lyapunov characterization of uniform exponential stability for nonlinear infinite-dimensional systems*, 67(4), 1685 - 1697, IEEE Transactions on Automatic Control, 2022.
7. [Ihab Haidar](#), Pierdomenico Pepe, *Lyapunov–Krasovskii characterizations of input-to-state stability for switching retarded systems*, 59(4), 2997-3016, SIAM Journal on Control and Optimization (SICON), 2021.
8. [Ihab Haidar](#), Pierdomenico Pepe, *Lyapunov–Krasovskii characterizations of stability notions for switching retarded systems*, IEEE Transactions on Automatic Control, doi: 10.1109/TAC.2020.2979754, 2020.

9. Ihab Haidar, Florentina Nicolau, Jean-Pierre Barbot and Woihida Aggoune, *Input-output linearization of SISO time-varying delay systems*, IMA Journal of Mathematical Control and Information, pp. 1-24, 2019.
10. H el ene Frankowska and Ihab Haidar, *A relaxation result for state constrained delay differential inclusions*, IEEE Transactions on Automatic Control, vol. 63, no. 11, pp. 3751-3760, Nov. 2018.
11. Ihab Haidar, Isabelle Alvarez and Anne-Caroline Pr evot, *Mathematical modeling of urban pigeon population subject to local management strategies*, Journal of Mathematical Biosciences, 288, 71–83, 2017.
12. Ihab Haidar, William Pasillas-L epine, Antoine Chaillet, Elena Panteley, St ephane Palfi and Suhan Senova, *A firing-rate regulation strategy for closed-loop deep brain stimulation*, Biological Cybernetics, 110(1), 55–71, 2016.
13. Ihab Haidar, Paolo Mason and Mario Sigalotti, *Converse Lyapunov–Krasovskii theorems for uncertain retarded differential equations*, Automatica, 62, 263-273, 2015.
14. Alain Rapaport, Ihab Haidar and J er ome Harmand, *Global dynamics of the buffered chemostat with non-monotonic response functions*, Journal of Mathematical Biology, 7(1), 69–98, 2015.
15. Ihab Haidar, William Pasillas-L epine, Elena Panteley, Antoine Chaillet, St ephane Palfi and Suhan Senova, *Generation of pathological basal ganglia oscillations: analysis using control theory approach*, International Journal of Control, 87(9), 1936–1956, 2014.
16. Ihab Haidar, Fr ed eric G erard and Alain Rapaport, *Effects of spatial structure and diffusion on the performances of the chemostat*, Mathematical Biosciences and Engineering, 8(4), 953–971, 2011.
17. Ihab Haidar, Fr ed eric G erard and Alain Rapaport, *Comparison of numerical simulations of reactive transport and chemostat-like models*, Computational Ecology and Software, 1(4), 224–239, 2011.

Patent

18. Alain Rapaport, J er ome Harmand and Ihab Haidar, *Stabilisation de proc ed es biotechnologiques pr esentant une instabilit e due   une inhibition par le substrat, par des configurations de type "poche"*, Brevet d'invention n  BNT210061FR00, F evrier 2012.

Book chapter

19. Ihab Haidar, Paolo Mason and Mario Sigalotti, *Stability of interconnected uncertain delay systems: a converse Lyapunov approach*, Delays and Interconnections: Methodology, Algorithms and Applications, G. Valmorbida and A. Seuret and I. Boussaada and R. Sipahi, Volume 10, Springer, 2019.

Conference papers

20. Ihab Haidar, *Non-coercive Lyapunov–Krasovskii functionals for exponential stability of time-varying delay systems: a switched system approach*, 10th International Conference on Systems and Control (ICSC), 2022.
21. Yacine Chitour, Ihab Haidar, Paolo Mason and Mario Sigalotti, *Stability criteria for singularly perturbed linear switching systems*, 10th International Conference on Systems and Control (ICSC), 2022.
22. Mariem Makni, Ihab Haidar, Jean-Pierre Barbot and Franc Plestan, *Active fault tolerant control through sparse recovery diagnosis*, 10th International Conference on Systems and Control (ICSC), 2022.
23. Ihab Haidar, Pierdomenico Pepe, *ISS characterization of retarded switching systems with relaxed Lyapunov–Krasovskii functionals*, 61st IEEE Conference on Decision and Control (CDC), 2022.
24. Mariem Makni, Ihab Haidar, Jean-Pierre Barbot, Franc Plestan, Nabih Feki, M. Slim Abbes, *Active fault tolerant control for twin wind turbine subject to asymmetric fault*, International Conference on Control, Automation and Diagnosis (ICCAD), 2021.
25. Ihab Haidar, Jean Pierre Barbot and Alain Rapaport, *Illustration of the application of the multi-observers approach*, 9th International Conference on Systems and Control (ICSC), 2021.
26. Florentina Nicolau, Ihab Haidar, Jean-Pierre Barbot and Woihida Aggoune, *Input-output decoupling and linearization of nonlinear multi-input multi-output time-varying delay systems*, 21st IFAC World Congress, 2020.
27. Mariem Makni, Ihab Haidar, Jean-Pierre Barbot, Franck Plestan, Nabih Feki, Mohamed Slim Abbes, *Analysis and control of Twin Wind Turbine subject to asymmetric fault*, IEEE Conference on Control Technology and Applications (CCTA), 2020.
28. Ihab Haidar, Yacine Chitour, Paolo Mason and Mario Sigalotti, *Converse Lyapunov theorems for infinite-dimensional nonlinear switching systems*, 58th IEEE Conference on Decision and Control (CDC), 2019.
29. Ihab Haidar, Jean-Pierre Barbot and Alain Rapaport, *A multi observers approach when observability index is higher than the state dimension- a case study-*, 58th IEEE Conference on Decision and Control (CDC), 2019.
30. H el ene Frankowska and Ihab Haidar, *Viable trajectories for non-convex differential inclusions with constant delay*, 14th IFAC Workshop on Time Delay Systems, 51(14), 33–38, Budapest, Hungary, June 28-30, 2018.
31. Florentina Nicolau, Ihab Haidar, Jean-Pierre Barbot and Woihida Aggoune, *Input-output decoupling and linearization of nonlinear two-input two-output time-varying delay systems*, 23rd International Symposium on Mathematical Theory of Networks and Systems Hong Kong University of Science and Technology, Hong Kong, July 16-20, 2018.

32. Ihab Haidar, Jean-Pierre Barbot, Alain Rapaport and Malek Ghanes, *Observability singularity of batch bioreactors: a solution based on high order sliding mode differentiator approach*, 11th Asian Control Conference (ASCC), 2017.
33. Ihab Haidar, Florentina Nicolau, Jean-Pierre Barbot and Woihida Aggoune, *Further remarks on Input-output linearization of SISO time-varying delay systems*, SIAM Conference on Control and its Applications 2017.
34. Ihab Haidar, Florentina Nicolau, Jean-Pierre Barbot and Woihida Aggoune, *Input-output linearization of SISO nonlinear time-varying delay systems*, 20th IFAC World Congress 2017.
35. Ihab Haidar, Paolo Mason, Silviu Niculescu, Mario Sigalotti and Antoine Chaillet, *Further remarks on Markus-Yamabe instability for time-varying delay differential equations*, 12th IFAC Workshop on Time Delay Systems, pages 33–38, Ann Arbor, MI, USA, June 2015.
36. Ihab Haidar, Paolo Mason and Mario Sigalotti, *Converse Lyapunov–Krasovskii theorems for uncertain time-delay systems*, The 19th IFAC World Congress, pages 10096-10100, Cape Town, South Africa, Aug. 2014.
37. William Pasillas-Lépine, Ihab Haidar, Antoine Chaillet and Elena Panteley, *Closed-loop Deep Brain Stimulation Based on Firing-rate Regulation*, Neural Engineering (NER), 2013 6th International IEEE/EMBS, pages 166–169, San Diego, USA, Nov. 2013.
38. Ihab Haidar, William Pasillas-Lépine, Elena Panteley and Antoine Chaillet, *Basal ganglia oscillations: the role of delays and external excitatory nuclei*, IEEE European Control Conference (ECC), pages 4083–4088, Zurich, Switzerland, July 2013.
39. Alain Rapaport, Ihab Haidar and Jérôme Harmand, *Global stability of chemostat under growth inhibition with a buffer interconnection*, 9th IFAC Symposium on Nonlinear Control Systems (NOLCOS 2013), Toulouse, France, Sep. 2013.
40. Ihab Haidar and Alain Rapaport, *Effects of spatial structure and diffusion on the performances of the chemostat*, Colloque Sciences et Techniques de l’Information et de la Communication pour l’Environnement 2011, pages 87–100, Saint-Etienne, France, Juin 2011.

Abbreviations

- UGAS** Uniformly globally asymptotically stable
- UGES** Uniformly globally exponentially stable
- USGES** Uniformly semiglobally exponentially stable
- ULES** Uniformly locally exponentially stable
- UES** Uniformly exponentially stable
- ISS** Input-to-state stable
- M-ISS** Input-to-state stable with measurable inputs
- PC-ISS** Input-to-state stable with piecewise-constant inputs
- RFC** Robustly forward complet
- REP** Robust equilibrium point
- NFT** Neighboring feasible trajectory
- ODE** Ordinary differential equation
- DBS** Deep brain stimualtion
- STN** Subthalamic nucleus
- GPe** External globus pallidus
- PPN** Pedunculopontine nucleus
- MPPT** Maximum power point tracking

Notations

\mathbb{R} The set of real numbers

\mathbb{R}_+ The set of non-negative real numbers

$\overline{\mathbb{R}}$ The extended real line

\mathbb{C} The set of complex numbers

$\Re(z)$ The real part of complex number z

$\Im(z)$ The imaginary part of complex number z

i The imaginary unit number

$\|\cdot\|$ The Euclidean norm

$(\mathbb{R}^n, \|\cdot\|)$ The n -dimensional Euclidean space, where n is a positive integer

$\langle \cdot, \cdot \rangle$ The inner product in \mathbb{R}^n

\otimes The Kronecker product of matrices

$B(0, r)$ The closed ball of $(\mathbb{R}^n, \|\cdot\|)$ of center 0 and radius $r > 0$

B The closed ball $B(0, 1)$

$\mathbb{1}_I$ The indicator function of a nonempty subset I of \mathbb{R}

$co K$ the convex hull of a subset K of \mathbb{R}^n

$\text{Int } K$ The interior of a nonempty closed subset K of \mathbb{R}^n

∂K The boundary of a nonempty closed subset K of \mathbb{R}^n

$d_K(x)$ The distance from $x \in \mathbb{R}^n$ to $K \subset \mathbb{R}^n$ defined by $d_K(x) = \inf_{y \in K} \|x - y\|$

$u_{[t_1, t_2]}$ The function given by $u \times \mathbb{1}_{[t_1, t_2]}$ for $u : \mathbb{R}_+ \rightarrow \mathbb{R}^m$ and $t_2 > t_1 \geq 0$

$\frac{\partial f}{\partial x}$ The partial derivative of a function f with respect to the variable x

$L_f h$ The Lie derivative of h along f given by $L_f h = \frac{\partial h}{\partial x} f$

$L_f^m h$ The m -order Lie derivative of f along h given by $L_f^m h = \frac{\partial L_f^{m-1} h}{\partial x} f$, for $m \geq 2$

$\|\cdot\|_\infty$ The norm of uniform convergence

$\mathcal{C}([-\Delta, 0], \mathbb{R}^n)$ The Banach space of continuous functions mapping $[-\Delta, 0]$, $\Delta > 0$, into \mathbb{R}^n

$\mathcal{C}_H(\phi)([-\Delta, 0], \mathbb{R}^n)$ The subset $\{\psi \in \mathcal{C}([-\Delta, 0], \mathbb{R}^n) : \|\phi - \psi\|_\infty \leq H\}$, $H > 0$, $\phi \in \mathcal{C}([-\Delta, 0], \mathbb{R}^n)$

$\mathcal{C}_H(0)([-\Delta, 0], \mathbb{R}^n)$ The set $\mathcal{C}_H(0)([-\Delta, 0], \mathbb{R}^n)$

$L^p(\Omega, \mathbb{R}^m)$ The space of functions $f : \Omega \rightarrow \mathbb{R}^m$, $\Omega \subset \mathbb{R}^n$, such that f^p is Lebesgue integrable

$L^p(\Omega)$ The space $L^p(\Omega, \mathbb{R}^m)$ with $\Omega \subset \mathbb{R}^m$

$H^1([-\Delta, 0], \mathbb{R}^n)$ The set of functions $f : [-\Delta, 0] \rightarrow \mathbb{R}^n$ such that f and $\frac{\partial f}{\partial x} \in L^1([-\Delta, 0], \mathbb{R}^n)$

$H^p(\Omega)$ The set of L^p -functions f with partial derivatives $D^\alpha f \in L^p(\Omega)$, $\forall \alpha$ such that $|\alpha| \leq p$

$H_0^1(\Omega)$ The set of functions $f \in H^1(\Omega)$ such that $f|_{\partial\Omega} = 0$

\mathcal{K} The set of continuous, strictly increasing functions $\alpha : \mathbb{R}_+ \rightarrow \mathbb{R}_+$ such that $\alpha(0) = 0$

\mathcal{K}_∞ The set of unbounded class \mathcal{K} functions

\mathcal{KL} The set of continuous functions $\beta : \mathbb{R}_+ \times \mathbb{R}_+ \rightarrow \mathbb{R}_+$ such that $\beta(\cdot, t)$ is of class \mathcal{K} for each $t \geq 0$ and $\beta(s, \cdot)$ is nonincreasing and converges to zero as t tends to $+\infty$, for each $s \geq 0$

Chapter 1

Lyapunov stability characterisation for infinite-dimensional switching systems

1.1 Abstract

The results presented in this chapter concern the stability of infinite-dimensional switching systems. Stability results which are uniform with respect to switching signals are obtained. Two classes of systems are considered: the class of abstract forward complete dynamical systems and the class of retarded functional differential equations. The applicability of the obtained results is shown through some academic examples. These results are obtained in collaboration with Yacine CHITOUR, Paolo MASON, Pierdomenico PEPE and Mario SIGALOTTI [70, 71, 75, 76, 77, 84, 85, 86].

1.2 Introduction

Many complex systems encountered in practice result from switching phenomenon between different individual subsystems. Mathematically, a switching system can be defined by an indexed family of dynamical subsystems and a rule that orchestrates the switching between them. The problem of stability of such class of systems has motivated an interesting branch in the literature of control theory (see, e.g., [3, 15, 28, 32, 95, 117, 118, 129, 180, 192] and references therein). Various works have been then devoted to the characterisation of the stability of infinite-dimensional systems in Banach spaces and, more specifically, of switching retarded systems through *coercive* and *non-coercive* Lyapunov functionals (see, e.g., [91, 139, 140]). By non-coercive Lyapunov functional, we mean a positive definite functional decaying along the trajectories of the system and satisfies

$$0 < V(x) \leq \alpha(\|x\|), \quad \forall x \in X \setminus \{0\}, \quad (1.1)$$

where X is the ambient Banach space and α belongs to the class of \mathcal{K}_∞ functions. Such a function V would be coercive if there existed $\alpha_0 \in \mathcal{K}_\infty$ such that $V(x) \geq \alpha_0(\|x\|)$ for every $x \in X$. In the literature, Lyapunov functionals satisfying (1.1) are equivalently called *weakly-degenerate* (see, e.g., [76]). In [140] it has been proved that the existence of a coercive Lyapunov functional V represents a necessary and sufficient condition for the global asymptotic stability for a general class of infinite-dimensional forward complete dynamical systems. However, a non-coercive Lyapunov functional does not guarantee global asymptotic stability and some additional regularity assumption on the dynamics is needed (see, e.g., [91, 140]). Stability results based on non-coercive Lyapunov functionals may be more easily applied in practice, while the existence of a coercive Lyapunov functional may be exploited to infer additional information on a stable nonlinear system. Converse Lyapunov theorems can be helpful for many applications, such as robustness and stability analysis of interconnected systems [77], the characterisation of the ISS property (see, e.g., [98, 162, 185]), and stability of sampled systems [159].

Throughout this section the word *uniform* will refer to uniformity with respect to switching signals.

1.3 Notations and definitions

Recall the following definition of an abstract forward complete dynamical system evolving in a Banach space X .

Definition 1 ([140]) *Let Q be a nonempty set. Denote by \mathcal{S} a set of signals $\sigma : \mathbb{R}_+ \rightarrow Q$ satisfying the following conditions:*

- a) \mathcal{S} is closed by time-shift, i.e., for all $\sigma \in \mathcal{S}$ and all $\tau \geq 0$, the τ -shifted signal $\mathbb{T}_\tau\sigma$ given by $\mathbb{T}_\tau\sigma : s \mapsto \sigma(\tau + s)$ belongs to \mathcal{S} ;
- b) \mathcal{S} is closed by concatenation, i.e., for all $\sigma_1, \sigma_2 \in \mathcal{S}$ and all $\tau > 0$ the signal σ defined by $\sigma \equiv \sigma_1$ over $[0, \tau]$ and by $\sigma(\tau + t) = \sigma_2(t)$ for all $t > 0$, belongs to \mathcal{S} .

Let $\phi : \mathbb{R}_+ \times X \times \mathcal{S} \rightarrow X$ be a map. The triple $\Sigma = (X, \mathcal{S}, \phi)$ is said to be a forward complete dynamical system if the following properties hold:

- i) For every $(x, \sigma) \in X \times \mathcal{S}$ and $\forall t \geq 0$, the value $\phi(t, x, \sigma)$ is well-defined in X ;
- ii) For every $(x, \sigma) \in X \times \mathcal{S}$, it holds that $\phi(0, x, \sigma) = x$;
- iii) For every $(x, \sigma) \in X \times \mathcal{S}$, $t \geq 0$, and $\tilde{\sigma} \in \mathcal{S}$ such that $\tilde{\sigma} = \sigma$ over $[0, t]$, it holds that $\phi(t, x, \tilde{\sigma}) = \phi(t, x, \sigma)$;
- iv) For every $(x, \sigma) \in X \times \mathcal{S}$, the map $t \mapsto \phi(t, x, \sigma)$ is continuous;
- v) For every $t, \tau \geq 0$ and $(x, \sigma) \in X \times \mathcal{S}$, it holds that $\phi(\tau, \phi(t, x, \sigma), \mathbb{T}_t \sigma) = \phi(t + \tau, x, \sigma)$.

We will refer to ϕ as the transition map of Σ . We denote by \mathcal{S}^{PC} the set of piecewise-constant signals in \mathcal{S} .

Various notions of uniform asymptotic stability of system Σ are given by the following definition.

Definition 2 Consider the forward complete dynamical system $\Sigma = (X, \mathcal{S}, \phi)$.

1. We say that system Σ is uniformly globally asymptotically stable at the origin (UGAS, for short), if there exist a function $\beta \in \mathcal{KL}$ such that the transition map ϕ satisfies the inequality

$$\|\phi(t, x, \sigma)\| \leq \beta(\|x\|, t), \quad \forall t \geq 0, \forall x \in X, \forall \sigma \in \mathcal{S}.$$

2. We say that Σ is uniformly globally exponentially stable at the origin (UGES, for short) if there exist $M > 0$ and $\lambda > 0$ such that the transition map ϕ satisfies the inequality

$$\|\phi(t, x, \sigma)\| \leq M e^{-\lambda t} \|x\|, \quad \forall t \geq 0, \forall x \in X, \forall \sigma \in \mathcal{S}.$$

3. We say that Σ is uniformly locally exponentially stable at the origin (ULES, for short) if there exist $r > 0$, $M > 0$, and $\lambda > 0$ such that the transition map ϕ satisfies the inequality

$$\|\phi(t, x, \sigma)\| \leq M e^{-\lambda t} \|x\|, \quad \forall t \geq 0, \forall x \in B_X(0, r), \forall \sigma \in \mathcal{S}. \quad (1.2)$$

If inequality (1.2) holds true for a given $r > 0$ then we say that Σ is uniformly exponentially stable at the origin in $B_X(0, r)$ (UES in $B_X(0, r)$, for short).

4. We say that Σ is uniformly semi-globally exponentially stable at the origin (USGES, for short) if, for every $r > 0$ there exist $M(r) > 0$ and $\lambda(r) > 0$ such that the transition map ϕ satisfies the inequality

$$\|\phi(t, x, \sigma)\| \leq M(r) e^{-\lambda(r)t} \|x\|, \quad \forall t \geq 0, \forall x \in B_X(0, r), \forall \sigma \in \mathcal{S}. \quad (1.3)$$

Observe that if Σ is a forward complete dynamical system and \mathcal{S} contains a constant function σ then $(\phi(t, \cdot, \sigma))_{t \geq 0}$ is a strongly continuous nonlinear semigroup, whose definition is recalled below.

Definition 3 [141] Let $T(t) : X \rightarrow X$, $t \geq 0$, be a family of nonlinear maps. We say that $(T(t))_{t \geq 0}$ is a strongly continuous nonlinear semigroup if the following properties hold:

- i) For every $x \in X$, it holds that $T(0)x = x$;
- ii) For every $t_1, t_2 \geq 0$, it holds that $T(t_1)T(t_2)x = T(t_1 + t_2)x$;
- iii) For every $x \in X$, the map $t \mapsto T(t)x$ is continuous.

An example of forward complete dynamical system is given next.

Example 4 (Piecewise-constant switching systems) Consider a family of strongly continuous nonlinear semigroups $(T_q(t))_{t \geq 0}$ in a Banach space X , parametrised by $q \in \mathbb{Q}$. Let $\sigma \in \mathcal{S}^{\text{PC}}$ be constantly equal to σ_k over $[t_k, t_{k+1})$, with $0 = t_0 < t_1 < \dots < t_k < t < t_{k+1}$, for $k \geq 0$. By concatenating the flows $(T_{\sigma_k}(t))_{t \geq 0}$, one can associate with σ the family of nonlinear evolution operators

$$T_\sigma(t) := T_{\sigma_k}(t - t_k)T_{\sigma_{k-1}}(t_k - t_{k-1}) \cdots T_{\sigma_1}(t_1),$$

$t \in [t_k, t_{k+1})$. Then, the triple $\Sigma = (X, \mathcal{S}^{\text{PC}}, \phi)$, with the transition map ϕ defined as

$$\phi(t, x_0, \sigma) = T_\sigma(t)x_0, \quad x_0 \in X, \sigma \in \mathcal{S}^{\text{PC}}, \quad (1.4)$$

is a forward complete dynamical system.

Example 5 (Semilinear switching systems) Let X, U be two Banach spaces. Consider the semilinear switching control system

$$\begin{cases} \dot{x}(t) = Ax(t) + f_{\sigma(t)}(x(t), u(t)), & t \geq 0, \\ x(0) = x_0 \in X, \end{cases} \quad (1.5)$$

where A is the infinitesimal generator of a C_0 -semigroup $(T(t))_{t \in \mathbb{R}}$ of bounded linear operators on X , $\sigma \in \mathcal{S}^{\text{PC}}$ is constantly equal to σ_k over $[t_k, t_{k+1})$, with $0 = t_0 < t_1 < \dots < t_k < t < t_{k+1}$, for $k \geq 0$; $f_{\sigma_k} : X \times U \rightarrow X$ is a Lipschitz continuous nonlinear operator, with Lipschitz constant $L_f > 0$ independent of σ_k , such that $f_{\sigma_k}(0, 0) = 0$, for $k \geq 0$; $u \in \mathcal{C}(\mathbb{R}_+, U)$ is the control input. For every $k \geq 0$ and $x_0 \in X$ there exists a unique mild solution of (1.5) over $[0, +\infty)$, with $\sigma \equiv \sigma_k$, i.e., a continuous function $x(\cdot)$ satisfying

$$x(t) = T(t)x_0 + \int_0^t T(t-s)f_{\sigma_k}(x(\tau), u(s)) ds,$$

for every $t \geq 0$. This defines a family $(T_{\sigma_k}(t))_{t \geq 0}$ of nonlinear maps by setting $T_{\sigma_k}(t)x_0 = x(t)$, for $t \geq 0$. As in Example 4, by concatenating the flows $(T_{\sigma_k}(t))_{t \geq 0}$, one can associate with σ the family of nonlinear evolution operators given by (1.4). Then the triple $\Sigma = (X, \mathcal{S}^{\text{PC}}, \phi_u)$ with the transition map ϕ_u is defined as in (1.4) is a forward complete dynamical system

The \mathcal{S} -uniform continuity of ϕ is defined as follows.

Definition 6 We say that the transition map ϕ of $\Sigma = (X, \mathcal{S}, \phi)$ is \mathcal{S} -uniformly continuous if, for every $\bar{t} > 0$, $x \in X$, and $\varepsilon > 0$, there exists $R > 0$ such that

$$\|\phi(t, x, \sigma) - \phi(t, y, \sigma)\| \leq \varepsilon, \quad \forall t \in [0, \bar{t}], \forall y \in B_X(x, R), \forall \sigma \in \mathcal{S}.$$

Similarly, the notion of \mathcal{S} -uniform Lipschitz continuity of the transition map is given by the following definition.

Definition 7 We say that the transition map ϕ of $\Sigma = (X, \mathcal{S}, \phi)$ is \mathcal{S} -uniformly Lipschitz continuous (respectively, \mathcal{S} -uniformly Lipschitz continuous on bounded sets) if, for every $\bar{t} > 0$ (respectively, $\bar{t} > 0$ and $R > 0$), there exists $l(\bar{t}) > 0$ (respectively, $l(\bar{t}, R) > 0$) such that

$$\|\phi(t, x, \sigma) - \phi(t, y, \sigma)\| \leq l(\bar{t})\|x - y\|, \quad \forall t \in [0, \bar{t}], \forall x, y \in X, \forall \sigma \in \mathcal{S}$$

(respectively,

$$\|\phi(t, x, \sigma) - \phi(t, y, \sigma)\| \leq l(\bar{t}, R)\|x - y\|, \quad \forall t \in [0, \bar{t}], \forall x, y \in B_X(0, R), \forall \sigma \in \mathcal{S}.$$

Let us recall the definition of Dini derivative of a functional $V : X \rightarrow \mathbb{R}_+$.

Definition 8 Consider a forward complete dynamical system $\Sigma = (X, \mathcal{S}, \phi)$. Given $\sigma \in \mathcal{S}$, the upper- and lower-right Dini derivatives $\overline{D}_\sigma V : X \rightarrow \overline{\mathbb{R}}$ and $\underline{D}_\sigma V : X \rightarrow \overline{\mathbb{R}}$ of a functional $V : X \rightarrow \mathbb{R}_+$ are defined, respectively, as

$$\overline{D}_\sigma V(x) = \limsup_{h \downarrow 0} \frac{1}{h} (V(\phi(h, x, \sigma)) - V(x)), \quad \forall x \in X,$$

and

$$\underline{D}_\sigma V(x) = \liminf_{h \downarrow 0} \frac{1}{h} (V(\phi(h, x, \sigma)) - V(x)), \quad \forall x \in X.$$

Remark 9 When \mathcal{S} contains piecewise-constant signals, we can associate with every $q \in \mathcal{Q}$ the upper and lower Dini derivatives $\overline{D}_q V$ and $\underline{D}_q V$ corresponding to $\sigma \equiv q$. By consequence, we have $\overline{D}_\sigma V(\varphi) = \overline{D}_q V(\varphi)$ and $\underline{D}_\sigma V(\varphi) = \underline{D}_q V(\varphi)$. In this case, we denote by $\overline{D}V$ and $\underline{D}V$ the following quantities

$$\overline{D}V(x) = \sup_{q \in \mathcal{Q}} \limsup_{h \downarrow 0} \frac{1}{h} (V(\phi(h, x, q)) - V(x)), \quad \forall x \in X,$$

and

$$\underline{D}V(x) = \sup_{q \in \mathcal{Q}} \liminf_{h \downarrow 0} \frac{1}{h} (V(\phi(h, x, q)) - V(x)), \quad \forall x \in X.$$

1.4 Converse Lyapunov theorems for infinite-dimensional switching systems

In this section we present the different converse theorems that we have obtained for an abstract forward complete dynamical system $\Sigma = (X, \mathcal{S}, \phi)$ and show some direct applications of the obtained results. Before, let us discuss the difference between coercive and non-coercive Lyapunov functionals.

1.4.1 Coercive vs non-coercive Lyapunov functionals

Recall, from [31], that the exponential stability of a linear C_0 -semigroup $(T(t))_{t \geq 0}$ on a complex Hilbert space H is equivalent to the existence of a positive Hermitian endomorphism B on

H such that the relation $2\Re(BAx, x) = -\|x\|^2$ holds for every x in the domain of A , the infinitesimal generator of the semigroup $(T(t))_{t \geq 0}$. In this case, we have

$$(Bx, x) = \int_0^{+\infty} \|T(t)x\|^2 dt, \quad \forall x \in H, \quad (1.6)$$

and, as reported in [156], the functional $V : X \rightarrow \mathbb{R}^+$ defined by $V(x) = (Bx, x)$ is in general a non-coercive Lyapunov functional since there does not exist in general a positive real number c such that

$$\int_0^{+\infty} \|T(t)x\|^2 dt \geq c\|x\|^2, \quad \forall x \in H. \quad (1.7)$$

Of course, in the case of finite-dimensional spaces, an exponential stable linear semigroup $(T(t))_{t \geq 0}$ is given by $(e^{tA})_{t \geq 0}$ with A Hurwitz and hence inequality (1.7) holds true.

Unlike autonomous linear systems in Banach spaces, the existence of non-coercive Lyapunov functional is not sufficient for the uniform exponential stability of switching linear systems. More precisely, even if there exists a functional $V : X \rightarrow \mathbb{R}_+$ which satisfies inequality (1.1) for some quadratic function α and decrease uniformly along each individual mode, an additional regularity condition is needed in order to get the UGES property of the system under consideration. This condition, given in [91], is as follows: there exist constants $M \geq 1$ and $\lambda > 0$ such that

$$\|T_\sigma(t)\|_{\mathcal{L}(X)} \leq Me^{\lambda t}, \quad \forall t \geq 0, \forall \sigma \in \mathcal{S}. \quad (1.8)$$

Observe that, in the case of autonomous linear systems, condition (1.8) holds as a property of strongly continuous semigroup (see, e.g., [157]).

In the case of a forward complete nonlinear system, additional regularity conditions like (1.8) are required for the UGAS and UGES properties when dealing with non-coercive Lyapunov functionals. These conditions are given in [140] and recalled in the sequel. Let us first recall the following two definitions:

Definition 10 ([140]) *The forward complete dynamical system $\Sigma = (X, \mathcal{S}, \phi)$ is said to be robustly forward complete (RFC, for short) if for any $C > 0$ and any $\tau > 0$ it holds that*

$$\sup_{\|x\| \leq C, t \in [0, \tau], \sigma \in \mathcal{S}} \|\phi(t, x, \sigma)\| < \infty.$$

Definition 11 ([140]) *We say that $0 \in X$ is a robust equilibrium point (REP, for short) of the forward complete dynamical system $\Sigma = (X, \mathcal{S}, \phi)$ if for every $\varepsilon, h > 0$, there exists $\delta = \delta(\varepsilon, h) > 0$, so that*

$$\|x\| \leq \delta \implies \|\phi(t, x, \sigma)\| \leq \varepsilon, \quad \forall t \in [0, h], \forall \sigma \in \mathcal{S}.$$

The existence of a non-coercive Lyapunov functional V , as shown in [140, Example 6.1], does not imply either the RFC or REP property, hence the necessity of both assumptions. One of the main results obtained in [140] relates the UGAS property with the existence of a non-coercive Lyapunov functional. This is formulated by the following theorem.

Theorem 12 [140, Theorem 3.5] *Consider a forward complete dynamical system $\Sigma = (X, \mathcal{S}, \phi)$ and assume that Σ is RFC and that 0 is a REP of Σ . If Σ admits a non-coercive Lyapunov functional, then it is UGAS.*

Stronger regularity conditions for ULES, USGES and UGES properties are given in [71] and recalled in the next section.

Example 13 (Example of non-coercive Lyapunov functional) *Consider the time-delay system*

$$\begin{aligned} \dot{x}(t) &= -x(t - \Delta), & t \geq 0, \\ x_0 &= \phi, \end{aligned} \quad (1.9)$$

where $\Delta \geq 0$ and $\phi \in \mathcal{C}([-\Delta, 0], \mathbb{R})$. It is well known (see, e.g., [88]) that system (1.9) is exponentially stable if and only if $\Delta < \pi/2$. In this case, a Lyapunov functional V can be defined by

$$V(\psi) = \int_0^{+\infty} \|T(t)\psi\|_\infty^2 dt,$$

where $T(t) : \mathcal{C}([-\Delta, 0], \mathbb{R}) \rightarrow \mathcal{C}([-\Delta, 0], \mathbb{R})$ is the C_0 -semigroup associated with (1.9) and defined by

$$T(t)\phi = x_t, \quad (1.10)$$

where $x_t : [-\Delta, 0] \rightarrow \mathbb{R}^n$ is the standard notation for the history function defined by

$$x_t(\theta) = x(t + \theta), \quad -\Delta \leq \theta \leq 0. \quad (1.11)$$

In the case of system (1.9), the Lyapunov functional V is non-coercive. In order to see this, we first recall that the spectrum of the infinitesimal generator A of $T(\cdot)$ is discrete and given by (see, e.g., [88])

$$\Lambda = \{\lambda \in \mathbb{C} : \lambda + e^{-\lambda\Delta} = 0\} = (\lambda_k)_{k \in \mathbb{N}}.$$

In addition, we have that $\lim_{k \rightarrow +\infty} \Re(\lambda_k) = -\infty$. For each $k \in \mathbb{N}$, let $v_k(\theta) = e^{\lambda_k(\Delta + \theta)}$, $\theta \in [-\Delta, 0]$ be an eigenvector of A corresponding to λ_k . Remark that $\lambda \in \Lambda$ if and only if $\bar{\lambda} \in \Lambda$. Associate with $\bar{\lambda}_k$ its eigenvector $\bar{v}_k(\theta) = e^{\bar{\lambda}_k(\Delta + \theta)}$, $\theta \in [-\Delta, 0]$, and let $\nu_k = (v_k + \bar{v}_k)/2 = \Re(v_k) \in \mathcal{C}([-\Delta, 0], \mathbb{R})$. Then

$$T(t)\nu_k(\theta) = \frac{e^{\lambda_k(t + \Delta + \theta)} + e^{\bar{\lambda}_k(t + \Delta + \theta)}}{2}. \quad (1.12)$$

Hence,

$$\begin{aligned} V(\nu_k) &= \int_0^{+\infty} \frac{\|e^{\lambda_k(t + \Delta + \theta)} + e^{\bar{\lambda}_k(t + \Delta + \theta)}\|_\infty^2}{4} dt \leq \int_0^{+\infty} \|e^{\Re(\lambda_k)(t + \Delta + \theta)}\|_\infty^2 dt \\ &= \int_0^{+\infty} e^{2\Re(\lambda_k)t} dt = -\frac{1}{2\Re(\lambda_k)}. \end{aligned}$$

Knowing that $\lim_{k \rightarrow +\infty} \Re(\lambda_k) = -\infty$, it follows that $V(\nu_k) \rightarrow 0$ as $k \rightarrow +\infty$. On the other hand, we have $\|\nu_k\|_\infty \geq \nu_k(-\Delta) = 1$. Then the Lyapunov function V does not have a strictly positive $\|\cdot\|_\infty$ -norm-dependent lower bound like in (1.7), and by consequence V is non-coercive.

Another choice of the Lyapunov functional is

$$\hat{V}(\psi) = \int_0^{+\infty} |(T(t)\psi)(0)|^2 dt.$$

In this case, by choosing $\hat{\nu}_k(\theta) = \Re(e^{\lambda_k\theta})$ we can easily verify that $\hat{V}(\hat{\nu}_k) \rightarrow 0$ as $k \rightarrow +\infty$ while $\hat{\nu}_k(0) = 1$ for every $k \geq 0$. Hence \hat{V} does not have a strictly positive $|\cdot|$ -norm-dependent lower bound.

1.4.2 Lyapunov functional for exponential stability characterisations

The following theorems show that the existence of a non-coercive Lyapunov functional is sufficient for the uniform exponential stability of the forward complete dynamical system Σ , provided that inequalities like the RFC property given by Definition 10 hold true.

Theorem 14 *Consider a forward complete dynamical system $\Sigma = (X, \mathcal{S}, \phi)$. Let $R > 0$, $t_1 > 0$ and γ be a function of class \mathcal{K}_∞ such that $\limsup_{r \downarrow 0} \frac{\gamma(r)}{r}$ is finite and*

$$\|\phi(t, x, \sigma)\| \leq \gamma(\|x\|), \quad \forall t \in [0, t_1], \forall x \in B_X(0, R), \forall \sigma \in \mathcal{S}. \quad (1.13)$$

If there exist a functional $V : B_X(0, R) \rightarrow \mathbb{R}_+$ and $p, c > 0$ such that

$$\begin{aligned} V(x) &\leq c\|x\|^p, \quad \forall x \in B_X(0, R), \\ \underline{D}_\sigma V(x) &\leq -\|x\|^p, \quad \forall x \in B_X(0, R), \forall \sigma \in \mathcal{S}, \end{aligned}$$

and $V(\phi(\cdot, x, \sigma))$ is continuous from the left at every $t > 0$ for which $\phi(t, x, \sigma) \in B_X(0, R)$, then system Σ is ULES.

Notice that RFC property of Σ is equivalent to inequality (1.13), although it does not necessarily imply that $\limsup_{r \downarrow 0} \frac{\beta(r)}{r}$ is finite.

Theorem 15 *Consider a forward complete dynamical system $\Sigma = (X, \mathcal{S}, \phi)$. Let $t_1 > 0$ and γ be a function of class \mathcal{K}_∞ such that $\limsup_{r \downarrow 0} \frac{\gamma(r)}{r}$ is finite and*

$$\|\phi(t, x, \sigma)\| \leq \gamma(\|x\|), \quad \forall t \in [0, t_1], \forall x \in X, \forall \sigma \in \mathcal{S}. \quad (1.14)$$

If, for every $R > 0$, there exist a functional $V_R : B_X(0, R) \rightarrow \mathbb{R}_+$ and $p_R, c_R > 0$ such that

$$\begin{aligned} V_R(x) &\leq c\|x\|^p, \quad \forall x \in B_X(0, R), \\ \underline{D}_\sigma V_R(x) &\leq -\|x\|^p, \quad \forall x \in B_X(0, R), \forall \sigma \in \mathcal{S}, \end{aligned}$$

and $V_R(\phi(\cdot, x, \sigma))$ is continuous from the left at every $t > 0$ for which $\phi(t, x, \sigma) \in B_X(0, R)$, and, moreover,

$$\limsup_{R \rightarrow +\infty} \gamma^{-1}(R) \min \left\{ 1, \left(\frac{t_1}{c_R} \right)^{\frac{1}{p_R}} \right\} = +\infty, \quad (1.15)$$

then system Σ is USGES.

Theorem 16 *Consider a forward complete dynamical system $\Sigma = (X, \mathcal{S}, \phi)$. Let $t_1 > 0$ such that*

$$\|\phi(t, x, \sigma)\| \leq G_0\|x\|, \quad \forall t \in [0, t_1], \forall x \in X, \forall \sigma \in \mathcal{S}. \quad (1.16)$$

with $G_0 \geq 1$ and there exist a functional $V : X \rightarrow \mathbb{R}_+$ and $p, c > 0$ such that

$$\begin{aligned} V(x) &\leq c\|x\|^p, \quad \forall x \in X, \\ \underline{D}_\sigma V(x) &\leq -\|x\|^p, \quad \forall x \in X, \forall \sigma \in \mathcal{S}, \end{aligned}$$

and the map $t \mapsto V(\phi(t, x, \sigma))$ is continuous from the left, then system Σ is UGES.

Remark 17 *By the shift-invariance properties given by items a) and iv) of Definition 1, it is easy to see that (1.16) implies*

$$\|\phi(t, x, \sigma)\| \leq Me^{\lambda t} \|x\|, \quad \forall t \geq 0, \forall x \in X, \forall \sigma \in \mathcal{S}, \quad (1.17)$$

where $M = G_0$ and $\lambda = \frac{\log(G_0)}{t_1}$. Notice that inequality (1.17) is a nontrivial requirement on system Σ . Even in the linear case, with (1.17) satisfied for each constant $\sigma \equiv q$, uniformly with respect to $q \in \mathcal{Q}$, it does not follow that a similar exponential bound holds for the corresponding system Σ (see [91, Example 1]).

The following theorem states that the existence of a coercive Lyapunov functional is necessary for the uniform exponential stability of a forward complete dynamical system.

Theorem 18 *Consider a forward complete dynamical system $\Sigma = (X, \mathcal{S}, \phi)$ and assume that the transition map ϕ is \mathcal{S} -uniformly continuous. If Σ is USGES then, for every $r > 0$ there exist $\underline{c}_r, \bar{c}_r > 0$ and a continuous functional $V_r : X \rightarrow \mathbb{R}_+$, such that*

$$\begin{aligned} \underline{c}_r \|x\| &\leq V_r(x) \leq \bar{c}_r \|x\|, \quad \forall x \in B_X(0, r), \\ \overline{D}_\sigma V_r(x) &\leq -\|x\|, \quad \forall x \in B_X(0, r), \forall \sigma \in \mathcal{S}, \\ V_r &= V_R \text{ on } X, \quad \forall R > 0 \text{ such that } \lambda(r) = \lambda(R) \text{ and } M(r) = M(R), \end{aligned}$$

where $\lambda(\cdot), M(\cdot)$ are as in (1.3). Moreover, in the case where the transition map ϕ is \mathcal{S} -uniformly Lipschitz continuous (respectively, \mathcal{S} -uniformly Lipschitz continuous on bounded sets), V_r can be taken Lipschitz continuous (respectively, Lipschitz continuous on bounded sets).

The following corollary characterises the uniform global exponential stability of a forward complete dynamical system, completing Theorem 16.

Corollary 19 *Consider a forward complete dynamical system $\Sigma = (X, \mathcal{S}, \phi)$. Assume that the transition map ϕ is \mathcal{S} -uniformly continuous. If there exist $t_1 > 0$ and $G_0 \geq 1$ such that condition (1.16) holds then the following statements are equivalent:*

- i) *System Σ is UGES;*
- ii) *there exists a continuous functional $V : X \rightarrow \mathbb{R}_+$ and positive reals p, \underline{c} , and \bar{c} such that*

$$\underline{c} \|x\|^p \leq V(x) \leq \bar{c} \|x\|^p, \quad \forall x \in X,$$

and

$$\overline{D}_\sigma V(x) \leq -\|x\|^p, \quad \forall x \in X, \forall \sigma \in \mathcal{S}; \quad (1.18)$$

- iii) *there exist a functional $V : X \rightarrow \mathbb{R}_+$ and positive reals p and c such that, for every $x \in X$ and $\sigma \in \mathcal{S}$, the map $t \mapsto V(\phi(t, x, \sigma))$ is continuous from the left, inequality (1.18) is satisfied and the following inequality holds*

$$V(x) \leq c \|x\|^p, \quad \forall x \in X.$$

1.4.3 Application: a link between exponential and input-to-state stability

The ISS property has been widely studied in the framework of complex systems such as general interconnected systems (see, e.g. [29, 30, 108]), switching finite-dimensional systems (see, e.g., [128] and references therein), time-delay systems (see, e.g., [23, 160, 187, 194] and references therein), and abstract infinite-dimensional systems (see, e.g., [136, 137, 138]). For example, in [138] a converse Lyapunov theorem characterising the ISS of a locally Lipschitz dynamics through the existence of a locally Lipschitz continuous coercive Lyapunov functional is given. Recently in [98] it has been shown that, under suitable regularity assumptions on the dynamics, the existence of non-coercive Lyapunov functionals implies ISS. In [71] we have provided a result of ISS type, proving that the input-to-state map has finite gain, under the assumption that the unforced system corresponding to (1.5) (i.e., with $u \equiv 0$) is uniformly globally exponentially stable. This result is not really original comparing to what is already developed in [98, 137, 138], but this is given as a direct application of the converse theorems given in Section 1.4.2.

Let X and U be two Banach spaces and consider the control system (1.5). Assume that the set of admissible controls is $L^p(U) := L^p(\mathbb{R}_+, U)$ with $1 \leq p \leq +\infty$. As in Example 5, we can define for every $x_0 \in X$, $\sigma \in \mathcal{S}^{\text{PC}}$, and $u \in L^p(U)$, the corresponding trajectory $\phi_u(t, x_0, \sigma)$ on \mathbb{R}_+ , which is continuous with respect to $(t, x_0, u) \in \mathbb{R}_+ \times X \times L^p(U)$. We have the following theorem.

Theorem 20 *Assume that the forward complete dynamical system $(X, \mathcal{S}^{\text{PC}}, \phi_0)$ is UGES. Then for every $1 \leq p \leq +\infty$ and $\sigma \in \mathcal{S}^{\text{PC}}$, the input-to-state map $u \mapsto \phi_u(\cdot, 0, \sigma)$ is well defined as a map from $L^p(U)$ to $L^p(X)$ and has a finite L^p -gain independent of σ , i.e., there exists $c_p > 0$ such that*

$$\|\phi_u(\cdot, 0, \sigma)\|_{L^p(X)} \leq c_p \|u\|_{L^p(U)}, \quad \forall u \in L^p(U), \forall \sigma \in \mathcal{S}^{\text{PC}}. \quad (1.19)$$

Theorem 20 in the same spirit as those obtained in [98, 137, 138]. In our particular context (UGES and global Lipschitz assumption) Theorem 20 proves that the input-to-state map $u \mapsto \phi_u(\cdot, 0, \sigma)$ has finite gain.

1.4.4 Application: predictor-based sampled data exponential stabilization

An interesting problem when dealing with a continuous-time model is the practical implementation of a designed feedback control. Indeed, in practice, due to numerical and technological limitations (sensors, actuators, and digital interfaces), a continuous measurement of the output and a continuous implementation of a feedback control are impossible. This means that the implemented input is, for almost every time, different from the designed controller. Several methods have been developed in the literature of ordinary differential equations for sampled-data observer design under discrete-time measurements (see, e.g., [6, 103, 133]), for sampled-data control design guaranteeing a globally stable closed-loop system (see, e.g., [2, 96]), and for optimal sampled-data control (see, e.g., [17]). Apart from time-delays systems (see, e.g., [51, 104, 159] for sampled-data control and [133, 134] for sampled-data observer design), few results exist for infinite-dimensional systems. The difficulties come from the fact that the developed methods do not directly apply to the infinite-dimensional case, for which even the well-posedness of

sampled-data control dynamics is not obvious (see, e.g., [105] for more details). Some interesting results have been obtained for infinite-dimensional linear systems [105, 119, 190]. In the nonlinear case no standard methods have been developed and the problem is treated case by case [110].

Let us focus on the particular problem of feedback stabilization under sampled output measurements of the abstract semilinear infinite-dimensional system (1.5). Assume that only discrete output measurements are available

$$y(t) = x(t_k), \quad \forall t \in [t_k, t_{k+1}), \quad \forall k \geq 0, \quad (1.20)$$

where $(t_k)_{k \geq 0}$ denotes the increasing sequence of sampling times. Suppose that system (1.5) in closed-loop with

$$u(t) = K(x(t)), \quad \forall t \geq 0, \quad (1.21)$$

where $K : X \rightarrow U$ is a Lipschitz continuous function satisfying $K(0) = 0$, is uniformly semi-globally exponentially stable. Assume also that A is the infinitesimal generator of a C_0 -group, i.e., there exist $\Gamma, \omega > 0$ such that

$$\|T(t)\| \leq \Gamma e^{\omega|t|}, \quad \forall t \in \mathbb{R}. \quad (1.22)$$

Let us give the following definition.

Definition 21 *Let $0 < s_1 < \dots < s_k < \dots$ be an increasing sequence of times such that $\lim_{k \rightarrow +\infty} s_k = +\infty$. The instants s_k are called sampling instants and the quantity*

$$\delta = \sup_{k \geq 0} (s_{k+1} - s_k)$$

is called the maximal sampling time. By predictor-based sampled data controller we mean a feedback $u(\cdot)$ of the type

$$u(t) = K(T(t - s_k)x(s_k)), \quad \forall t \in [s_k, s_{k+1}), \quad \forall k \geq 0. \quad (1.23)$$

We denote by $\Sigma_0 = (X, \mathcal{S}^{\text{PC}}, \phi^{\Sigma_0})$ and $\Sigma = (X, \mathcal{S}^{\text{PC}}, \phi^{\Sigma})$ the forward complete dynamical systems corresponding to (1.5)–(1.21) and (1.5)–(1.23), respectively. The following theorem, proved in [71], gives sufficient condition for the exponential stability preservation of system Σ provided that Σ_0 is uniformly semi-globally exponentially stable.

Theorem 22 *If system Σ_0 is USGES and*

$$\lim_{r \rightarrow \infty} \frac{r}{M(r)} = +\infty, \quad (1.24)$$

where $M(r)$ is as in (1.3), then for every $r > 0$ there exists $\delta^(r) > 0$ such that Σ is UES in $B_X(0, r)$, provided that the maximal sampling time of $(s_k)_{k \in \mathbb{N}}$ is smaller than $\delta^*(r)$. In addition, if $\inf_{r \geq 0} \delta^*(r) > 0$ then Σ is USGES.*

When Σ_0 is uniformly globally exponentially stable, we have the following result.

Corollary 23 *Suppose that system Σ_0 is UGES. Then there exists $\delta^* > 0$ such that system Σ is UGES provided that the maximal sampling time of $(s_k)_{k \in \mathbb{N}}$ is smaller than δ^* .*

The following example shows the applicability of Corollary 23 on the exponential stabilisation of a switching damped wave equation with sampled data feedback.

Example 24 (Sample-data exponential stabilisation of a switching wave equation)

Let Ω be a bounded open domain of class C^2 in \mathbb{R}^n , $n \geq 1$, and consider the switching damped wave equation

$$\begin{cases} \frac{\partial^2 \psi}{\partial t^2} - \Delta \psi + \rho_{\sigma(t)} \left(\frac{\partial \psi}{\partial t} \right) = 0 & \text{in } \Omega \times \mathbb{R}_+, \\ \psi = 0 & \text{on } \partial\Omega \times \mathbb{R}_+, \\ \psi(0) = \psi_0, \psi'(0) = \psi_1 & \text{on } \Omega, \end{cases} \quad (1.25)$$

where $\sigma : \mathbb{R}_+ \rightarrow \mathbb{Q}$ is a piecewise-constant function and $\rho_q : \mathbb{R} \rightarrow \mathbb{R}$, for $q \in \mathbb{Q}$, is a uniformly Lipschitz continuous function satisfying

$$\rho_q(0) = 0, \quad \alpha|v| \leq |\rho_q(v)| \leq \frac{|v|}{\alpha}, \quad \forall v \in \mathbb{R}, \forall q \in \mathbb{Q},$$

for some $\alpha > 0$. In the case where $\tilde{\rho}(t, v) := \rho_{\sigma(t)}(v)$ is sufficiently regular, namely a continuous function differentiable on $\mathbb{R}_+ \times (-\infty, 0)$ and $\mathbb{R}_+ \times (0, \infty)$, and $v \mapsto \tilde{\rho}(t, v)$ is nondecreasing, for each initial condition (ψ_0, ψ_1) taken in $H^2(\Omega) \cap H_0^1(\Omega) \times H_0^1(\Omega)$ there exists a unique strong solution for (1.25) in a suitable space \mathbf{H} (see [131] for more details). For the switching damped wave equation (1.25) the existence and uniqueness of a strong solution (in \mathbf{H}) is given by concatenation. Defining the energy of the solution of (1.25) by

$$E(t) = \frac{1}{2} \int_{\Omega} \left(\frac{\partial \psi}{\partial t}^2 + |\nabla \psi|^2 \right) dx,$$

we can prove, following the same lines of the proof of [131, Theorem 1], that the energy of the solutions in \mathbf{H} decays uniformly (with respect to the initial condition) exponentially to zero as

$$E(t) \leq e^{1-\mu t} E(0), \quad \forall t \geq 0,$$

for some $\mu > 0$ that depends only on α . Let X be the Banach space $H_0^1(\Omega) \times L^2(\Omega)$ endowed with the norm

$$\|x\| = \|\nabla x_1\|_{L^2(\Omega)}^2 + \|x_2\|_{L^2(\Omega)}^2,$$

and let A be the linear operator defined on X by

$$A = \begin{pmatrix} 0 & I \\ \Delta & 0 \end{pmatrix}, \quad D(A) = \left\{ x = \begin{pmatrix} x_1 \\ x_2 \end{pmatrix} \in X \mid x_1 \in H^2(\Omega) \cap H_0^1(\Omega), x_2 \in H_0^1(\Omega) \right\},$$

where I is the identity operator and Δ denotes the Laplace operator. It is well known that $D(A)$ is dense in X and that A is the infinitesimal generator of a C_0 -group of bounded linear operators $(T_t)_{t \in \mathbb{R}}$ on X satisfying

$$\|T(t)\| = 1, \quad \forall t \in \mathbb{R}.$$

With this formulation, equation (1.25) can be rewritten as the initial value problem (1.5) with feedback

$$u(t) = x_2(t) \text{ and } f_q(x, u) = \begin{pmatrix} 0 \\ \rho_s(u) \end{pmatrix}.$$

The associated transition map satisfies the inequality

$$\|\phi(t, x, \sigma)\| \leq e^{1-\mu t} \|x\|, \quad \forall t \geq 0. \quad (1.26)$$

Note that the constant μ does not depend on the solution. Using the density of $D(A)$ in X , inequality (1.26) holds true for weak solutions. Thus system (1.5) corresponding to (1.25) is UGES. The assumptions of Corollary 23 being satisfied, we deduce that for a sufficiently small maximal sampling time the predictor-based sampled data feedback (1.23) preserves the exponential decay to zero of the energy of the solutions of (1.5).

1.4.5 Application: retarded systems with uncertain delay

After representing a nonlinear retarded functional differential equation as an abstract forward complete dynamical system, all the characterisations of uniform exponential stability provided in Section 1.4.2 can be applied to this particular class of infinite-dimensional systems. In particular, we can characterise the uniform global exponential stability of a retarded functional differential equation in terms of the existence of coercive and non-coercive Lyapunov functionals.

Consider the nonlinear retarded system

$$\begin{cases} \dot{x}(t) = f_{\sigma(t)}(x_t), & t \geq 0, \\ x(\theta) = \varphi(\theta), & \theta \in [-\Delta, 0], \end{cases} \quad (1.27)$$

where $x(t) \in \mathbb{R}^n$, $\varphi \in \mathcal{C}([-\Delta, 0], \mathbb{R}^n)$, x_t is the history state defined by (1.11), $\sigma \in \mathcal{S}^{\text{PC}}$ and $f_q : \mathcal{C}([-\Delta, 0], \mathbb{R}^n) \rightarrow \mathbb{R}^n$ is a continuous functional such that $f_q(0) = 0$ for all $q \in \mathcal{Q}$.

For every $q \in \mathcal{Q}$ and $\varphi \in \mathcal{C}([-\Delta, 0], \mathbb{R}^n)$, we assume that system (1.27), with $\sigma(t) \equiv q$, admits a unique solution over $[0, +\infty)$. This defines a family $(T_q(t))_{t \geq 0}$ of nonlinear maps from $\mathcal{C}([-\Delta, 0], \mathbb{R}^n)$ into itself by setting

$$T_q(t)\varphi = x_t, \quad \forall t \geq 0.$$

According to [191], $(T_q(t))_{t \geq 0}$ is a strongly continuous semigroup of nonlinear operators on $\mathcal{C}([-\Delta, 0], \mathbb{R}^n)$.

We denote by $(\mathcal{C}([-\Delta, 0], \mathbb{R}^n), \mathcal{S}^{\text{PC}}, \phi_0^\Delta)$, where ϕ_0^Δ is the transition map constructed as in Example 4, the forward complete dynamical system corresponding to (1.27). As a consequence of the switching representation of the nonlinear time-varying delay system (1.27), the results of the previous section (in particular Theorem 16 and Corollary 19) apply to system (1.27). Let us explicitly provide an application of Corollary 19.

Theorem 25 *Let $L > 0$ be such that*

$$|f_q(\psi_1) - f_q(\psi_2)| \leq L \|\psi_1 - \psi_2\|_\infty, \quad \forall \psi_1, \psi_2 \in \mathcal{C}([-\Delta, 0], \mathbb{R}^n), \quad \forall q \in \mathcal{Q}. \quad (1.28)$$

The following statements are equivalent:

- i) *System $(\mathcal{C}([-\Delta, 0], \mathbb{R}^n), \mathcal{S}^{\text{PC}}, \phi_0^\Delta)$ is UGES;*
- ii) *there exists a continuous functional $V : \mathcal{C}([-\Delta, 0], \mathbb{R}^n) \rightarrow \mathbb{R}_+$ and positive reals p, \underline{c} , and \bar{c} such that*

$$\underline{c} \|\psi\|_\infty^p \leq V(\psi) \leq \bar{c} \|\psi\|_\infty^p, \quad \forall \psi \in \mathcal{C}([-\Delta, 0], \mathbb{R}^n),$$

and

$$\overline{D}V(\psi) \leq -\|\psi\|_\infty^p, \quad \forall \psi \in \mathcal{C}([-\Delta, 0], \mathbb{R}^n); \quad (1.29)$$

iii) there exist a functional $V : \mathcal{C}([-\Delta, 0], \mathbb{R}^n) \rightarrow \mathbb{R}_+$ and positive reals p and c such that, for every $\psi \in \mathcal{C}$ and $q \in \mathcal{Q}$, the map $t \mapsto V(T_q(\cdot)\psi)$ is continuous from the left, inequality (1.29) is satisfied, and

$$V(\psi) \leq c\|\psi\|_\infty^p, \quad \forall \psi \in \mathcal{C}([-\Delta, 0], \mathbb{R}^n).$$

1.5 Converse Lyapunov theorems for switching retarded linear systems

Consider the following switching retarded linear system

$$\begin{cases} \dot{x}(t) = \Gamma_{\sigma(t)}x_t, & t \geq 0, \\ x(\theta) = \varphi(\theta), & \theta \in [-\Delta, 0], \end{cases} \quad (1.30)$$

where $x(t) \in \mathbb{R}^n$, φ is the initial condition and $\sigma \in \mathcal{S}$ be such that the operator $\Gamma_{\sigma(\cdot)}$ takes values in a bounded subset \mathcal{Q} of $\mathcal{L}(\mathcal{C}([-\Delta, 0], \mathbb{R}^n), \mathbb{R}^n)$.

In the case of linear retarded systems of type (1.30), more elaborated results than Theorem 25 have been obtained in [76]. More precisely, two phase spaces have been considered $X = \mathcal{C}([-\Delta, 0], \mathbb{R}^n)$ and $X = H^1([-\Delta, 0], \mathbb{R}^n)$. In addition, more general class of switching signals like Lebesgue measurable ones have been considered. Let us denote by \mathcal{S}^M the subset of Lebesgue Measurable signals, i.e., the set of signals such that $\Gamma_{\sigma(\cdot)} : \mathbb{R}_+ \rightarrow \mathcal{Q}$ is Lebesgue Measurable.

Before giving these results, let us first recall the definition of Fréchet derivative of a functional $V : X \rightarrow \mathbb{R}_+$.

Definition 26 *V is said to be directionally differentiable in the sense of Fréchet at $\psi \in X$ if there exists a positively one-homogeneous functional $V'(\psi, \cdot) : X \rightarrow \mathbb{R}$ such that*

$$\frac{V(\psi + \xi) - V(\psi) - V'(\psi, \xi)}{\|\xi\|_X} \rightarrow 0 \quad \text{as } \xi \rightarrow 0.$$

In particular, for every $\xi \in X$, the directional derivative of V at ψ in the direction ξ is well defined and it is equal to $V'(\psi, \xi)$.

One can easily verify the existence and uniqueness of solutions for (1.30) in X . Let ϕ_Γ be the transition map relative to system (1.30). We denote by $(X, \mathcal{S}^Y, \phi_\Gamma)$, with $Y = \text{PC}$ or $Y = \text{M}$, the forward complete dynamical system corresponding to (1.30). The following theorem is proved in [76].

Theorem 27 *The following statements are equivalent:*

- (i) *System $(\mathcal{C}([-\Delta, 0], \mathbb{R}^n), \mathcal{S}^{\text{PC}}, \phi_\Gamma)$ is UGES.*
- (ii) *System $(H^1([-\Delta, 0], \mathbb{R}^n), \mathcal{S}^{\text{PC}}, \phi_\Gamma)$ is UGES.*
- (iii) *System $(\mathcal{C}([-\Delta, 0], \mathbb{R}^n), \mathcal{S}^{\text{M}}, \phi_\Gamma)$ is UGES.*
- (iv) *System $(H^1([-\Delta, 0], \mathbb{R}^n), \mathcal{S}^{\text{M}}, \phi_\Gamma)$ is UGES.*

(v) There exists a functional $V : \mathcal{C}([-\Delta, 0], \mathbb{R}^n) \rightarrow \mathbb{R}_+$ such that $\sqrt{V(\cdot)}$ is a norm on $\mathcal{C}([-\Delta, 0], \mathbb{R}^n)$,

$$\underline{c}\|\psi\|_\infty^2 \leq V(\psi) \leq \bar{c}\|\psi\|_\infty^2, \quad \forall \psi \in \mathcal{C}([-\Delta, 0], \mathbb{R}^n),$$

for some constants $\underline{c}, \bar{c} > 0$ and

$$\overline{D}V(\psi) \leq -\|\psi\|_\infty^2, \quad \forall \psi \in \mathcal{C}([-\Delta, 0], \mathbb{R}^n).$$

(vi) There exists a directionally Fréchet differentiable functional $V : H^1([-\Delta, 0], \mathbb{R}^n) \rightarrow \mathbb{R}_+$ such that $\sqrt{V(\cdot)}$ is a norm on $H^1([-\Delta, 0], \mathbb{R}^n)$,

$$\begin{aligned} \underline{c}\|\psi\|_{H^1}^2 &\leq V(\psi) \leq \bar{c}\|\psi\|_{H^1}^2, & \forall \psi \in H^1([-\Delta, 0], \mathbb{R}^n) \\ |V'(\psi, \xi)| &\leq \bar{c}\|\psi\|_{H^1}\|\xi\|_{H^1}, & \forall \psi, \xi \in H^1([-\Delta, 0], \mathbb{R}^n) \\ V'(\psi, \xi_1 + \xi_2) &\leq V'(\psi, \xi_1) + V'(\psi, \xi_2), & \forall \psi, \xi_1, \xi_2 \in H^1([-\Delta, 0], \mathbb{R}^n) \end{aligned}$$

for some constants $\underline{c}, \bar{c} > 0$ and

$$\overline{D}V(\psi) \leq -\|\psi\|_{H^1}^2, \quad \forall \psi \in H^1([-\Delta, 0], \mathbb{R}^n).$$

If $\psi \in D(\mathcal{A}_q)$, where \mathcal{A}_q is the infinitesimal generator associated to (1.30) for $\sigma \equiv q$, then $\overline{D}V(\psi) = \sup_{q \in \mathcal{Q}} V'(\psi, \mathcal{A}_q \psi)$.

(vii) There exists a continuous functional $V : \mathcal{C}([-\Delta, 0], \mathbb{R}^n) \rightarrow \mathbb{R}_+$ such that

$$V(\psi) \leq c\|\psi\|_\infty^2, \quad \forall \psi \in \mathcal{C}([-\Delta, 0], \mathbb{R}^n),$$

for some constant $c > 0$ and

$$\underline{D}V(\psi) \leq -|\psi(0)|^2, \quad \forall \psi \in \mathcal{C}([-\Delta, 0], \mathbb{R}^n).$$

(viii) There exists a continuous functional $V : H^1([-\Delta, 0], \mathbb{R}^n) \rightarrow \mathbb{R}_+$ such that

$$V(\psi) \leq c\|\psi\|_{H^1}^2, \quad \forall \psi \in H^1([-\Delta, 0], \mathbb{R}^n),$$

for some constant $c > 0$ and

$$\underline{D}V(\psi) \leq -|\psi(0)|^2, \quad \forall \psi \in H^1([-\Delta, 0], \mathbb{R}^n).$$

1.5.1 Application: robustness with respect to perturbations

In this section we give a result which shows the effects of small perturbations on the stability of linear systems of type (1.30). The idea is to exploit the converse Lyapunov theorem 27.

Let \mathcal{P} be a bounded subset of $\mathcal{L}(\mathcal{C}([-\Delta, 0], \mathbb{R}^n), \mathbb{R}^n)$. Here \mathcal{P} has to be regarded as a set of bounded perturbations of the operators in \mathcal{Q} . In the case where system (1.30) is UGES, the stability of the perturbed system

$$\dot{x}(t) = (\Gamma_{\sigma(t)} + \Lambda_{\sigma(t)})x_t, \tag{1.31}$$

where $\sigma \in \mathcal{S}$ is such that $\Gamma_{\sigma(t)} \in \mathcal{Q}$ and $\Lambda_{\sigma(t)} \in \mathcal{P}$ can be studied using the following proposition.

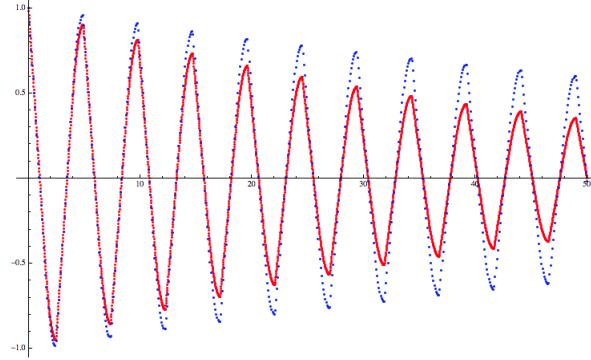

Figure 1.1: A solution of (1.32) (solid line) and a perturbation of it, solution of (1.33) (dotted line)

Proposition 28 *Let V be as in item v) of Theorem 27. Let $\ell = \sup_{\Lambda \in \mathcal{P}} \|\Lambda\|_{\mathcal{L}(\mathcal{C}([-\Delta, 0], \mathbb{R}^n), \mathbb{R}^n)}$. Then*

$$\overline{D}_{\Gamma+\Lambda}V(\psi) \leq \overline{D}_{\Gamma}V(\psi) + 2\ell c\|\psi\|_{\infty}^2 \quad \forall \psi \in \mathcal{C}([-\Delta, 0], \mathbb{R}^n),$$

where $\overline{D}_{\Gamma}V$ and $\overline{D}_{\Gamma+\Lambda}V$ are the upper right-hand Dini derivatives of V along systems (1.30) and (1.31), respectively.

We provide here an exemple of application of the previous result. This exemple may be found in [77].

Example 29 *Consider the scalar time-varying delay system*

$$\dot{x}(t) = -x(t - \tau(t)), \quad (1.32)$$

where $\tau(\cdot)$ is piecewise-constant and takes values in $[0, \Delta]$. It is known that (1.32) is uniformly exponentially stable in $\mathcal{C}([-\Delta, 0], \mathbb{R})$ if and only if $\Delta < 3/2$ [88].

Fix $\Delta < 3/2$ and consider the perturbed system

$$\dot{x}(t) = -x(t - \tau(t)) + \int_{-\bar{\Delta}}^0 a(s)x(t+s)ds, \quad (1.33)$$

where $a \in L^1([-\bar{\Delta}, 0], \mathbb{R})$ and $\bar{\Delta} \geq \Delta$ (notice that $\bar{\Delta}$ may be larger than $3/2$). Let $\Lambda : \mathcal{C}([-\bar{\Delta}, 0], \mathbb{R}) \rightarrow \mathbb{R}$ be defined by

$$\Lambda\psi = \int_{-\bar{\Delta}}^0 a(s)\psi(s)ds$$

and notice that $|\Lambda\psi| \leq \|a\|_{L^1}\|\psi\|_{\infty}$. Hence,

$$\overline{D}_{\Gamma+\Lambda}V(\psi) \leq \overline{D}_{\Gamma}V(\psi) + 2c\|a\|_{L^1}\|\psi\|_{\infty}^2 \leq (-1 + 2c\|a\|_{L^1})\|\psi\|_{\infty}^2,$$

where V is as in Theorem 27, Item v). If $\|a\|_{L^1} < 1/(2c)$ then (1.33) is uniformly exponentially stable in $\mathcal{C}([-\bar{\Delta}, 0], \mathbb{R})$.

1.5.2 Application: stability of interconnected switching retarded linear systems

Theorem 27 and Proposition dini-perturbation-bound can be used to study the stability of interconnected uncertain piecewise-constant delay systems.

For $i \in \{1, 2\}$, let \mathcal{Q}_i be a bounded subset of $\mathcal{L}(\mathcal{C}([-\Delta, 0], \mathbb{R}^{n_1}) \times \mathcal{C}([-\Delta, 0], \mathbb{R}^{n_2}), \mathbb{R}^{n_i})$ and consider the linear delay systems

$$\begin{cases} \dot{x}(t) &= \Gamma_{1,\sigma(t)}(x_t, 0), \\ x_0 &= \varphi_1 \end{cases} \quad \begin{cases} \dot{y}(t) &= \Gamma_{2,\sigma(t)}(0, y_t), \\ y_0 &= \varphi_2, \end{cases} \quad (1.34)$$

and the interconnected system

$$\begin{cases} \dot{z}(t) &= \Gamma_{\sigma(t)}z_t, \\ z_0 &= \varphi, \end{cases} \quad (1.35)$$

where $\sigma \in \mathcal{S}$ is such that $\Gamma_{1,\sigma(t)} \in \mathcal{Q}_1$, $\Gamma_{2,\sigma(t)} \in \mathcal{Q}_2$, $\Gamma_{\sigma(t)} \in \mathcal{Q}_1 \times \mathcal{Q}_2$, for all $t \geq 0$, $z = (x, y) \in \mathbb{R}^{n_1} \times \mathbb{R}^{n_2}$ and $\varphi = (\varphi_1, \varphi_2) \in \mathcal{C}([-\Delta, 0], \mathbb{R}^{n_1}) \times \mathcal{C}([-\Delta, 0], \mathbb{R}^{n_2})$.

Let ϕ_{Γ_1} , ϕ_{Γ_2} and ϕ_{Γ} be the transition maps associated to (1.34)-left, (1.34)-right and (1.35), respectively.

We have the following theorem from [77].

Theorem 30 *Let $X = X_1 \times X_2$ with $X_1 = \mathcal{C}([-\Delta, 0], \mathbb{R}^{n_1})$ and $X_2 = \mathcal{C}([-\Delta, 0], \mathbb{R}^{n_2})$. Assume that $(X_1, \mathcal{S}^M, \phi_{\Gamma_1})$ and $(X_2, \mathcal{S}^M, \phi_{\Gamma_2})$ are UGES in X_1 and X_2 , respectively. Let $V_i : X_i \rightarrow [0, \infty)$, $i \in \{1, 2\}$, be the Lyapunov functionals whose existence is guaranteed by Item v) of Theorem 27. Let c_1, c_2 be the upper-bound constants for V_1 and V_2 , respectively. Let*

$$\mu = \sup\{\|(L_1(0, \psi_2), L_2(\psi_1, 0))\|/\|\psi\|_X \mid L_1 \in \mathcal{Q}_1, L_2 \in \mathcal{Q}_2, \psi \in X, \psi \neq 0\}.$$

If $2 \max(c_1, c_2)\mu < 1$ then the interconnected system $(X, \mathcal{S}^M, \phi_{\Gamma})$ is UGES in X .

In the case of systems in cascade form, there is no need of imposing conditions on the non-diagonal block of the operator Γ , as stated below.

Corollary 31 *Assume that system (1.35) is in cascade form, namely $L_1(\phi_1, \phi_2) = L_1(\phi_1, 0)$ for any $L_1 \in \mathcal{Q}_1$ and $(\phi_1, \phi_2) \in X$. Then $(X, \mathcal{S}^M, \phi_{\Gamma})$ is UGES in X if and only if $(X_1, \mathcal{S}^M, \phi_{\Gamma_1})$ and $(X_2, \mathcal{S}^M, \phi_{\Gamma_2})$ are UGES in X_1 and X_2 , respectively.*

1.6 Converse Lyapunov theorems for nonlinear switching retarded systems

In this section we focus on the switching control system described by the following retarded functional differential equation

$$\begin{cases} \dot{x}(t) &= f_{\sigma(t)}(x_t, u(t)), & a.e. \ t \geq 0, \\ x(\theta) &= x_0(\theta), & \theta \in [-\Delta, 0], \end{cases} \quad (1.36)$$

where $x(t) \in \mathbb{R}^n$; $x_0 \in \mathcal{C}([-\Delta, 0], \mathbb{R}^n)$ is the initial state; $u \in \mathcal{U}^M$, the set of Lebesgue measurable locally essentially bounded inputs from \mathbb{R}_+ to \mathbb{R}^m , m positive integer; $\sigma \in \mathcal{S}^M$ the subset of

Lebesgue measurable signals, i.e., $t \mapsto f_{\sigma(t)}(\varphi, u(t))$ is Lebesgue measurable for each fixed $\varphi \in \mathcal{C}([-\Delta, 0], \mathbb{R}^n)$ and $u \in \mathcal{U}^M$.

Comparing to the result obtained by Theorem 25, here we show more elaborated results for switching retarded systems with the following relaxed regularity assumption.

Assumption 32 *For each $q \in \mathbb{Q}$, $f_q(0, 0) = 0$. Moreover, $f_q(\cdot, \cdot)$ is uniformly (with respect to $q \in \mathbb{Q}$) Lipschitz on bounded subsets of $\mathcal{C}([-\Delta, 0], \mathbb{R}^n) \times \mathbb{R}^m$, i.e., for any $H > 0$ there exists $L_H > 0$ such that for every $\psi_1, \psi_2 \in \mathcal{C}_H([-\Delta, 0], \mathbb{R}^n)$ and $u_1, u_2 \in B(0, H)$, the following inequality holds*

$$|f_q(\psi_1, u_1) - f_q(\psi_2, u_2)| \leq L_H (\|\psi_1 - \psi_2\|_\infty + |u_1 - u_2|), \quad \forall q \in \mathbb{Q}.$$

Under Assumption 32, the existence and uniqueness of a solution for system (1.36) over a maximal time interval $[0, b)$, with $0 < b \leq +\infty$, as well as its continuous dependence on the initial state is guaranteed by the theory of systems described by retarded functional differential equations (see, e.g., [88, 112]). This can be reformulated by the following lemma.

Lemma 33 *For any $\varphi \in \mathcal{C}([-\Delta, 0], \mathbb{R}^n)$, $u \in \mathcal{U}^M$ and $\sigma \in \mathcal{S}^M$, there exists, uniquely, a locally absolutely continuous solution $x(\cdot, \varphi, u, \sigma)$ of (1.36) in a maximal time interval $[0, b)$, with $0 < b \leq +\infty$. If $b < +\infty$, then the solution is unbounded in $[0, b)$. Moreover, for any $\varepsilon > 0$, for any $c \in (0, b)$, there exists $\delta > 0$ such that, for any $\varsigma \in \mathcal{C}_\delta(\varphi)([-\Delta, 0], \mathbb{R}^n)$, the solution $x(\cdot, \varsigma, u, \sigma)$ exists in $[0, c]$ and, furthermore, the following inequality holds*

$$|x(t, \varphi, u, \sigma) - x(t, \varsigma, u, \sigma)| \leq \varepsilon, \quad \forall t \in [0, c].$$

For each $\varphi \in \mathcal{C}([-\Delta, 0], \mathbb{R}^n)$, $u \in \mathcal{U}$ (\mathcal{U}^M or \mathcal{U}^{PC}) and $\sigma \in \mathcal{S}$ (\mathcal{S}^M or \mathcal{S}^{PC}), we define the transition map ϕ_u^Δ corresponding to (1.36) over $[0, b)$. In the case where $b = +\infty$ we denote by $\Sigma = (\mathcal{C}([-\Delta, 0], \mathbb{R}^n), \mathcal{S}, \phi_u^\Delta)$ the corresponding forward complete dynamical system.

Let us recall the following definition about Driver's form derivative of a continuous functional $V : \mathcal{C}([-\Delta, 0], \mathbb{R}^n) \rightarrow \mathbb{R}_+$. This definition is a variation of the one given in [37, 158, 160] for retarded functional differential equations without switching.

Definition 34 *For a continuous functional $V : \mathcal{C}([-\Delta, 0], \mathbb{R}^n) \rightarrow \mathbb{R}_+$, its Driver's form derivative, $D^+V : \mathcal{C}([-\Delta, 0], \mathbb{R}^n) \times \mathbb{R}^m \rightarrow \overline{\mathbb{R}}$, is defined, for the switching system (1.36), for $\varphi \in \mathcal{C}([-\Delta, 0], \mathbb{R}^n)$ and $u \in \mathbb{R}^m$, as follows,*

$$D^+V(\varphi, u) = \sup_{q \in \mathbb{Q}} \limsup_{h \rightarrow 0^+} \frac{V(\varphi_{h,u}^{\Sigma, q}) - V(\varphi)}{h}, \quad (1.37)$$

where $\varphi_{h,u}^{\Sigma, q} \in \mathcal{C}([-\Delta, 0], \mathbb{R}^n)$ is defined, for $h \in [0, \Delta)$ and $\theta \in [-\Delta, 0]$, as follows

$$\varphi_{h,u}^{\Sigma, q}(\theta) = \begin{cases} \varphi(\theta + h), & \theta \in [-\Delta, -h) \\ \varphi(0) + (\theta + h)f_q(\varphi, u), & \theta \in [-h, 0]. \end{cases}$$

Driver's type derivative, by contrast to Dini's one, is an appropriate definition of the derivative of a Lyapunov–Krasovskii functional that does not involve the solution.

Remark 35 Let us denote by \mathcal{U}^{PC} the subset of right-continuous piecewise-constant inputs. Fix $\varphi \in \mathcal{C}([-\Delta, 0], \mathbb{R}^n)$, $\sigma \in \mathcal{S}^{\text{PC}}$ and $u \in \mathcal{U}^{\text{PC}}$ and let $x(\cdot)$ be the locally absolutely continuous solution of (1.36) in a maximal interval $[0, b)$. One can verify (see [84, 64]) that

$$D^+V(x_t, u(t)) = \bar{D}V(x_t), \quad \forall t \in [0, b), \quad (1.38)$$

and that equality (1.38) becomes almost everywhere in $[0, b)$ in the case where $\sigma \in \mathcal{S}^{\text{M}}$ and/or $u \in \mathcal{U}^{\text{M}}$.

1.6.1 Input-to-state stability characterisation theorems

The proof of the results given in this section may be found in [84, 85].

Definition 36 We say that system $(\mathcal{C}([-\Delta, 0], \mathbb{R}^n), \mathcal{S}, \phi_u^\Delta)$ with $\mathcal{S} = \mathcal{S}^{\text{M}}$ (\mathcal{S}^{PC} , respectively) is M-ISS (PC-ISS, respectively) if there exist a function $\beta \in \mathcal{KL}$ and a class \mathcal{K} function γ such that, for any $x_0 \in \mathcal{C}([-\Delta, 0], \mathbb{R}^n)$, $u \in \mathcal{U}^{\text{M}}$ (\mathcal{U}^{PC} , respectively) and $\sigma \in \mathcal{S}^{\text{M}}$ (\mathcal{S}^{PC} , respectively), the corresponding solution exists in \mathbb{R}_+ and, furthermore, satisfies the inequality

$$\|\phi_u^\Delta(t, x_0, \sigma)\|_\infty \leq \beta(\|x_0\|_\infty, t) + \gamma(\|u_{[0,t]}\|_\infty), \quad \forall t \geq 0.$$

Two different characterisations of the input-to-state stability property of system (1.36) have been done in [85]. The first one is based on the following theorem which shows that the ISS property with measurable inputs and measurable switching signals can be equivalently studied through the class of piecewise-constant inputs and piecewise-constant switching signals.

Theorem 37 $(\mathcal{C}([-\Delta, 0], \mathbb{R}^n), \mathcal{S}^{\text{M}}, \phi_u^\Delta)$ is M-ISS $\iff (\mathcal{C}([-\Delta, 0], \mathbb{R}^n), \mathcal{S}^{\text{PC}}, \phi_u^\Delta)$ is PC-ISS.

Remark 38 The equivalence property given by Theorem 37 has a significant interest in the context of retarded systems. In fact, an important problem when dealing with retarded system concerns the regularity of Lyapunov–Krasovskii functionals. This is related to the map describing the evolution of the state which is simply continuous (instead of absolutely continuous) with respect to time (see, e.g., [88, Lemma 2.1]). Thus a continuous, or even Lipschitz on bounded sets, Lyapunov–Krasovskii functional evaluated on the solutions of such a system will be in general continuous and not absolutely continuous with respect to time. By consequence, when we deal with a retarded equation which holds almost everywhere (this is, for example, the case of systems with Lebesgue measurable inputs), the nonpositivity, almost everywhere, of the upper right-hand Dini derivative of a Lyapunov–Krasovskii functional is not sufficient to conclude about its monotonicity. Thanks to the equivalence property given by Theorem 37, this problem can be overcome by restricting the class of inputs and switching signals to the class of piecewise-constant ones. Indeed, in this case, the nonpositivity of the upper right-hand Dini derivative of a Lyapunov–Krasovskii functional evaluated on the solutions of a switching retarded system will hold everywhere instead of almost everywhere permitting to conclude about the monotonicity question (see [62]).

The second characterisation of the input-to-state stability property of system (1.36) is given through the existence of a common Lyapunov–Krasovskii functional. This theorem is given in [85]; it is in the spirit of the converse Lyapunov–Krasovskii theorems developed in [106, 107, 162] for systems described by retarded and neutral functional differential equations.

Theorem 39 *System $(\mathcal{C}([-\Delta, 0], \mathbb{R}^n), \mathcal{S}^M, \phi_u^\Delta)$ is M-ISS if and only if there exist a functional $V : \mathcal{C}([-\Delta, 0], \mathbb{R}^n) \rightarrow \mathbb{R}_+$, Lipschitz on bounded subsets of $\mathcal{C}([-\Delta, 0], \mathbb{R}^n)$, functions $\alpha_1, \alpha_2, \alpha_3 \in \mathcal{K}_\infty$, and $\alpha_4 \in \mathcal{K}$ such that the following inequalities hold:*

- (i) $\alpha_1(|\varphi(0)|) \leq V(\varphi) \leq \alpha_2(\|\varphi\|_\infty), \quad \forall \varphi \in \mathcal{C}([-\Delta, 0], \mathbb{R}^n),$
- (ii) $D^+V(\varphi, u) \leq -\alpha_3(\|\varphi\|_\infty) + \alpha_4(|u|), \quad \forall \varphi \in \mathcal{C}([-\Delta, 0], \mathbb{R}^n), \forall u \in \mathbb{R}^m.$

Recently, in [86], we obtain the following relaxed converse theorem characterising the ISS property of system (1.36) through the existence of continuous (instead of locally Lipschitz) Lyapunov-Krasovskii functional whose upper right-hand Dini derivative satisfies a dissipation inequality almost everywhere (instead of everywhere).

Theorem 40 *The following statements are equivalent:*

- 1) *System $(\mathcal{C}([-\Delta, 0], \mathbb{R}^n), \mathcal{S}^M, \phi_u^\Delta)$ is M-ISS;*
- 2) *there exist a Lipschitz on bounded sets functional $V : \mathcal{C}([-\Delta, 0], \mathbb{R}^n) \rightarrow \mathbb{R}_+$, functions $\alpha_1, \alpha_2, \alpha_3 \in \mathcal{K}_\infty$, and $\alpha_4 \in \mathcal{K}$ such that the following inequalities hold:*
 - (i) $\alpha_1(|\varphi(0)|) \leq V(\varphi) \leq \alpha_2(\|\varphi\|_\infty), \quad \forall \varphi \in \mathcal{C}([-\Delta, 0], \mathbb{R}^n),$
 - (ii) $D^+V(\varphi, u) \leq -\alpha_3(\|\varphi\|_\infty) + \alpha_4(|u|), \quad \forall \varphi \in \mathcal{C}([-\Delta, 0], \mathbb{R}^n), \forall u \in \mathbb{R}^m;$
- 3) *there exist a continuous functional $V : \mathcal{C}([-\Delta, 0], \mathbb{R}^n) \rightarrow \mathbb{R}_+$, functions $\alpha_1, \alpha_2, \alpha_3 \in \mathcal{K}_\infty$, and $\alpha_4 \in \mathcal{K}$ such that for any $u \in \mathcal{U}^M$ the following inequalities hold:*
 - (i) $\alpha_1(|\varphi(0)|) \leq V(\varphi) \leq \alpha_2(\|\varphi\|_\infty), \quad \forall \varphi \in \mathcal{C}([-\Delta, 0], \mathbb{R}^n),$
 - (ii) $\overline{D}V(x_t, u(t)) \leq -\alpha_3(\|x_t\|_\infty) + \alpha_4(|u(t)|), \quad \text{a.e. } t \in [0, b),$

where $x(\cdot)$ is the solution of (1.36) starting from φ and associated with u and σ over the maximal interval of definition $[0, b)$.

At the best of our knowledge, the ISS characterisation of system (1.36) by the existence of continuous (instead of locally Lipschitz) Lyapunov-Krasovskii functional whose upper right-hand Dini derivative satisfies the dissipation inequality in item 3) of Theorem 40 is new in the literature of retarded systems where at least locally Lipschitz regularity is needed for the Lyapunov-Krasovskii functional.

1.6.2 Asymptotic and exponential stability characterisation theorems

The following theorems provide necessary and sufficient conditions for the asymptotic and exponential stability properties of system (1.36) through the existence of a common Lyapunov-Krasovskii functional. We prove these results first in [84] in the case of piecewise-constant inputs and piecewise-constant switching signals, then these are extended to the case of measurable inputs and switching signals in [85].

Theorem 41 *System $(\mathcal{C}([-\Delta, 0], \mathbb{R}^n), \mathcal{S}^M, \phi_0^\Delta)$ is UGAS if and only if there exist a functional $V : \mathcal{C}([-\Delta, 0], \mathbb{R}^n) \rightarrow \mathbb{R}_+$, Lipschitz on bounded subsets of $\mathcal{C}([-\Delta, 0], \mathbb{R}^n)$, functions $\alpha_1, \alpha_2 \in \mathcal{K}_\infty$, and $\alpha_3 \in \mathcal{K}$ such that*

$$(i) \alpha_1(|\varphi(0)|) \leq V(\varphi) \leq \alpha_2(\|\varphi\|_\infty), \quad \forall \varphi \in \mathcal{C}([-\Delta, 0], \mathbb{R}^n),$$

$$(ii) D^+V(\varphi) \leq -\alpha_3(|\varphi(0)|), \quad \forall \varphi \in \mathcal{C}([-\Delta, 0], \mathbb{R}^n).$$

Theorem 42 *System $(\mathcal{C}([-\Delta, 0], \mathbb{R}^n), \mathcal{S}^M, \phi_0^\Delta)$ is UGES if and only if there exist a functional $V : \mathcal{C}([-\Delta, 0], \mathbb{R}^n) \rightarrow \mathbb{R}_+$, Lipschitz on bounded subsets of $\mathcal{C}([-\Delta, 0], \mathbb{R}^n)$, positive reals $\alpha_1, \alpha_2, \alpha_3$ and p such that*

$$(i) \alpha_1\|\varphi\|_\infty^p \leq V(\varphi) \leq \alpha_2\|\varphi\|_\infty^p, \quad \forall \varphi \in \mathcal{C}([-\Delta, 0], \mathbb{R}^n),$$

$$(ii) D^+V(\varphi) \leq -\alpha_3\|\varphi\|_\infty^p, \quad \forall \varphi \in \mathcal{C}([-\Delta, 0], \mathbb{R}^n).$$

The following theorem gives necessary and sufficient conditions for the ULES property of system (1.36).

Theorem 43 *System $(\mathcal{C}([-\Delta, 0], \mathbb{R}^n), \mathcal{S}^M, \phi_0^\Delta)$ is ULES if and only if there exist positive reals $H, p, \alpha_1, \alpha_2, \alpha_3$ and Lipschitz functional $V : \mathcal{C}_H([-\Delta, 0], \mathbb{R}^n) \rightarrow \mathbb{R}_+$ such that*

$$(i) \alpha_1\|\varphi\|_\infty^p \leq V(\varphi) \leq \alpha_2\|\varphi\|_\infty^p, \quad \forall \varphi \in \mathcal{C}_H([-\Delta, 0], \mathbb{R}^n),$$

$$(ii) D^+V(\varphi) \leq -\alpha_3\|\varphi\|_\infty^p, \quad \forall \varphi \in \mathcal{C}_H([-\Delta, 0], \mathbb{R}^n).$$

1.6.3 Application: a link between exponential and input-to-state stability

Thanks to the previous converse theorems, a link between the exponential stability of an unforced switching retarded system and the input-to-state stability is given by the following theorem proven in [85].

Theorem 44 *Suppose that system $(\mathcal{C}([-\Delta, 0], \mathbb{R}^n), \mathcal{S}^{\text{PC}}, \phi_0^\Delta)$ is UGES. If there exist positive reals L and l and a nonnegative real $p < 1$ such that*

- 1) $\forall \varphi, \psi \in \mathcal{C}([-\Delta, 0], \mathbb{R}^n), \forall u \in \mathbb{R}^m, \forall q \in \mathbb{Q}$, the following inequality holds

$$|f_q(\varphi, u) - f_q(\psi, u)| \leq L\|\varphi - \psi\|_\infty; \quad (1.39)$$

- 2) $\forall \varphi \in \mathcal{C}([-\Delta, 0], \mathbb{R}^n), \forall u \in \mathbb{R}^m, \forall q \in \mathbb{Q}$, the following inequality holds

$$|f_q(\varphi, u) - f_q(\varphi, 0)| \leq l \max\{\|\varphi\|_\infty^p, 1\}|u|; \quad (1.40)$$

then system $(\mathcal{C}([-\Delta, 0], \mathbb{R}^n), \mathcal{S}^M, \phi_u^\Delta)$ is M-ISS.

Example 45 (Robust stability of neural network with time-delays) *Consider the neural network with constant delays*

$$\dot{x}(t) = Ax(t) + g_{\sigma(t)}(x_t, u(t)), \quad (1.41)$$

where $A = \text{diag}(a_1, \dots, a_n)$, with $a_i < 0$ for $i \in \{1, \dots, n\}$, $\sigma : \mathbb{R}_+ \rightarrow \mathbb{Q}$ is a switching signal, $u : \mathbb{R}_+ \rightarrow \mathbb{R}^m$ is an external input and, for each fixed mode $q \in \mathbb{Q}$, the nonlinearity $g_q : \mathcal{C}([-\Delta, 0], \mathbb{R}^n) \times \mathbb{R}^m \rightarrow \mathbb{R}^n$ is given, for $(\varphi, u) \in \mathcal{C}([-\Delta, 0], \mathbb{R}^n) \times \mathbb{R}^m$, by

$$g_{i,q}(\varphi, u) = \sum_{j=1}^n b_{ij} f_{j,q}(\varphi_j(-\tau_{ij,q})) + u_i, \quad (1.42)$$

where $f_{j,q} \in \{f_1, \dots, f_n\}$ and $\tau_{ij,q} \in [0, \Delta]$, for all $i, j \in \{1, \dots, n\}$. For each $i \in \{1, \dots, n\}$ and $q \in \mathbb{Q}$ the function $f_{i,q}$ is uniformly globally Lipschitz with Lipschitz constant $\mu_i > 0$.

System (1.41) is useful in many applications such as signal processing, robotics and neuroscience, where, in general, the delays and even the vector field g may depend on different uncertain parameters and it is more suitable to consider a perturbed switching neural network with uncertain time-varying delays.

If the following condition is satisfied

$$a_i + \sum_{j=1}^n \mu_j |b_{ij}| < 0, \quad \text{for } i = 1, \dots, n, \quad (1.43)$$

it has been proven in [22] that each individual system is globally exponentially stable. Therefore, by [161, Theorem 2.5], there exists a globally Lipschitz functional $V : \mathcal{C}([-\Delta, 0], \mathbb{R}^n) \rightarrow \mathbb{R}_+$ with Lipschitz constant $\alpha_4 > 0$ such that the inequalities (i) and (ii) of Theorem 4.2 hold with $p = 1$. Computing the Driver's derivative of V for the switching system (1.41), in the case when $u \equiv 0$, gives

$$D^+V(\varphi) = \sup_{q \in \mathbb{Q}} \limsup_{h \rightarrow 0^+} \frac{V(\varphi_{h,0}^{\Sigma,q}) - V(\varphi)}{h} \leq -\alpha_3 \|\varphi\|_\infty + 2\bar{\mu}\alpha_4 \sqrt{\sum_{i=1}^n \left(\sum_{j=1}^n |b_{ij}| \right)^2} \|\varphi\|_\infty,$$

where $\bar{\mu} = \max\{\mu_1, \dots, \mu_n\}$. By consequence, by Theorem 4.2, in addition to condition (1.43), if the Lipschitz constants μ_i , for $i \in \{1, \dots, n\}$, are sufficiently small, then the global exponential stability of the non-perturbed system (1.41), i.e. with $u \equiv 0$, is preserved. In particular, if α_4 is known, sufficient condition for the global exponential stability of the non-perturbed system (1.41) is given by condition (1.43) together with the following inequality

$$\bar{\mu} \sqrt{\sum_{i=1}^n \left(\sum_{j=1}^n |b_{ij}| \right)^2} < \frac{\alpha_3}{2\alpha_4}. \quad (1.44)$$

In this case, thanks to Theorem 4.4, we have that the perturbed switching uncertain delay system (1.41) is input-to-state stable.

1.6.4 Application: stability by first order approximation

Another application of the developed converse theorems is the extension of the very well known first order approximation theorem to nonlinear switching retarded systems. In [85] we show that a nonlinear switching retarded system is uniformly locally exponentially stable if and only if its linearised one is uniformly globally exponentially stable, provided that, for each mode, the nonlinear map describing the related dynamics is Fréchet differentiable at the origin.

Assumption 46 *Let, for $q \in \mathbb{Q}$, the map f_q be Fréchet differentiable at 0, and let L_q be the Fréchet derivative at 0. Suppose that L_q is uniformly (with respect to $q \in \mathbb{Q}$) bounded, i.e., there exists $m > 0$, such that*

$$|L_q \varphi| \leq m \|\varphi\|_\infty, \quad \forall \varphi \in \mathcal{C}([-\Delta, 0], \mathbb{R}^n), \forall q \in \mathbb{Q}.$$

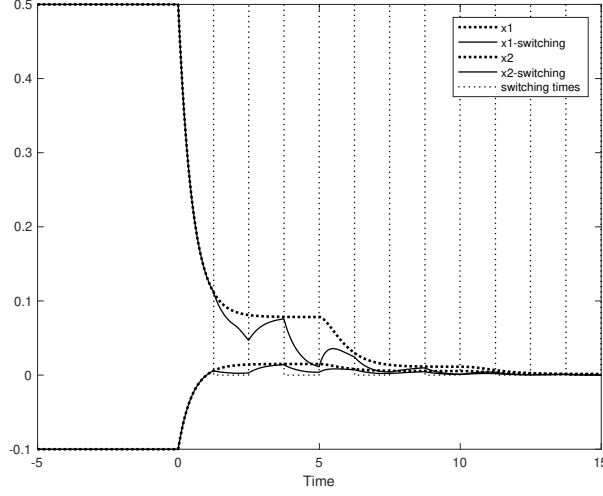

Figure 1.2: Simulation relative to Example 45 with $a_1 = a_2 = -2$, $b_{11} = b_{22} = 0.3$, $b_{12} = -b_{21} = 0.1$, $\tau_{11} = \tau_{12} = \tau_{21} = \tau_{22} = 5$ and the nonlinearities are $f_1(x) = \frac{|x+1|-|x-1|}{2}$ and $f_2(x) = \frac{|x+1|-|x-1|}{3}$ (dotted lines, without switching). In the case of this simulation $f_{j,q}$ switches in $\{f_1, f_2\}$ and the delay switches between 3 and 5 (solide lines, with switching).

Theorem 47 *Suppose that Assumption 46 holds. Then system $(\mathcal{C}([-\Delta, 0], \mathbb{R}^n), \mathcal{S}^M, \phi_0^\Delta)$ is ULES if and only if the system $(\mathcal{C}([-\Delta, 0], \mathbb{R}^n), \mathcal{S}^{PC}, \phi_L)$, where ϕ_L is the transition map associated to the linear switching system*

$$\begin{aligned} \dot{\xi}(t) &= L_{\sigma(t)}\xi_t, & a.e. t \geq 0, \\ \xi(\theta) &= \xi_0(\theta), & \theta \in [-\Delta, 0], \end{aligned}$$

with $\xi_0 \in \mathcal{C}([-\Delta, 0], \mathbb{R}^n)$, is UGES.

Theorem 47 is very useful in practice. In fact, thanks to this theorem the local stability analysis of a nonlinear switching retarded system can be then reduced to the stability analysis of a switching linear one, for which many useful methods exist in the literature (see, e.g., [132]).

Example 48 *Consider a system described by the following equation*

$$\begin{aligned} \dot{x}(t) &= Ax(t) + Bx(t - \tau_0) + C(\tau_1(t)) (x(t - \tau_2(t)) \otimes x(t - \tau_3(t))), & a.e. t \geq 0, \\ x(\theta) &= x_0(\theta), & \theta \in [-\Delta, 0], \end{aligned} \quad (1.45)$$

where: $x(t) \in \mathbb{R}^n$; $\tau_0 \in [0, \Delta]$; $\tau_1, \tau_2, \tau_3 : \mathbb{R}_+ \rightarrow [0, \Delta]$ are measurable uncertain functions; A and B are $n \times n$ real matrices; the matrix function $C : [0, \Delta] \rightarrow \mathbb{R}^{n \times n^2}$ is continuous. Let $\mathcal{Q} = [0, \Delta]^3$ and let $\tau : \mathbb{R} \rightarrow \mathcal{Q}$ be the measurable function, which is defined, for each $t \in \mathbb{R}_+$, by $\tau(t) = (\tau_1(t), \tau_2(t), \tau_3(t))$. For each $q = (q_1, q_2, q_3) \in \mathcal{Q}$, let the function $f_q : \mathcal{C}([-\Delta, 0], \mathbb{R}^n) \rightarrow \mathbb{R}^n$ be defined, for $\varphi \in \mathcal{C}([-\Delta, 0], \mathbb{R}^n)$, as

$$f_q(\varphi) = A\varphi(0) + B\varphi(-\tau_0) + C(q_1) (\varphi(-q_2) \otimes \varphi(-q_3)).$$

System (1.45) can be equivalently written as system (1.36). By Theorem 47, system (1.45) is ULES if and only if the linear, time-invariant system described by

$$\begin{aligned}\dot{\xi}(t) &= A\xi(t) + B\xi(t - \tau_0), & t \geq 0, \\ \xi(\theta) &= x_0(\theta), & \theta \in [-\Delta, 0],\end{aligned}\tag{1.46}$$

is UGES. Many methods, such as the ones based on LMIs, are available in the literature which permit to examine the exponential stability of systems like (1.46) (see, e.g., [52, 150] and references therein). If, in the case of system (1.46), these LMIs are verified, then the ULES property of system (1.45) follows from Theorem 47.

Chapter 2

Input-output linearisation and relaxation results for time-delay control systems

2.1 Abstract

The results presented in this chapter concern time-delay systems. The first part is devoted around the property of input-output linearisation of nonlinear time-varying delay systems. The second part presents some relaxation theorems for state constrained delay differential inclusions. These results are obtained in collaboration with Woihida AGGOUNE, Jean-Pierre BARBOT, H el ene FRANKOWSKA and Florentina NICOLAU [43, 44, 78, 79, 80, 149, 148].

2.2 Introduction

Other interesting mathematical properties concerning time-delay systems are considered in this chapter. The first section is devoted around the input-output linearisation of nonlinear time-varying delay systems. The input-output linearisation approach is an important tool in nonlinear control theory which consists, after the application of a suitable feedback transformation, in finding a direct linear relation between the input and the output of the system. The problem of input-output linearisation is well known for nonlinear control systems without delays (see, e.g., [100], for input-state linearisation, and [34, 97], for input-output decoupling and linearisation). Various aspects of those problems have been studied in the literature using different approaches and some of those approaches have been extended to encompass nonlinear control systems with constant delays (see, e.g., [9, 21], for the algebraic approach, and [57, 152], for the geometric one). However, for time-varying delay systems the problem of input-output linearisation is particularly different and this for two fundamental reasons: 1) the lack of an algebraic representation like the case of constant-delay systems and 2) the inadequacy of the geometric approach to perfectly cover infinite-dimensional systems. In [79, 78, 80], by adopting the geometric approach developed for finite-dimensional systems, we give some sufficient conditions guarantying the solvability of the input-output linearisation of time-varying delay systems. These conditions, in the case of single-input single-output, are recalled in this chapter. The case of multi-input multi-output case is treated in [148, 149].

The second section of this chapter is about a relaxation result obtained in [43] for state constrained delay differential inclusions. Differential inclusions is a convenient tool to work with various types of control systems (see, e.g., [7]). For instance, a closed loop system can be written as a differential inclusion where, at each state, the set-valued map is defined by the set of all possible feedback controls at this state. Also, differential inclusions are helpful to study control systems with uncertainties, where the set-valued map incorporates model errors. In the presence of state constraints, the investigation of such differential inclusions becomes very difficult and the analysis of existence of viable trajectories has occupied a considerable attention in the literature (see, e.g., [7, 45, 47]). The existence of viable trajectories is closely related to the convexity of the values of the set-valued map defining the differential inclusion [7]. When the set-valued map fails to be convex many works were devoted to give regularity conditions allowing to approximate relaxed feasible trajectories by feasible trajectories and provide estimates on the distance of a given trajectory of unconstrained control system from the set of its feasible trajectories, see for instance [42, 45, 47, 49, 50]. In this chapter we present the results obtained in [43] aiming to extend these relaxation theorems to delay differential inclusions.

2.3 Input-output linearisation of time-varying delay systems

Consider the following single-input single-output time-varying delay control system

$$\begin{aligned}
 \dot{x}(t) &= f(t, x_t) + g_0(t, x_t)u(t) + g_1(t, x_t)u(t - \tau(t)), \quad \forall t \geq 0, \\
 y(t) &= h(t, x_t), \\
 x(\theta) &= x_0(\theta), \quad \forall \theta \in [-\Delta, 0], \\
 u(\theta) &= u_0(\theta), \quad \forall \theta \in [-\Delta, 0],
 \end{aligned} \tag{2.1}$$

where $x(t) \in \mathbb{R}^n$, the vector fields $f, g_0, g_1 : \mathbb{R}_+ \times \mathcal{C}([-\Delta, 0], \mathbb{R}^n) \rightarrow \mathbb{R}^n$ and the function $h : \mathbb{R}_+ \times \mathcal{C}([-\Delta, 0], \mathbb{R}^n) \rightarrow \mathbb{R}$ are sufficiently smooth. The initial condition x_0 belongs to $\mathcal{C}([-\Delta, 0], \mathbb{R}^n)$ and the input $u : [-\Delta, +\infty) \rightarrow \mathbb{R}$ is a Lebesgue measurable function. We also assume that system (2.1) is forward complete.

Unlike for systems without delay, even if a full input-output linearisation has been achieved (i.e., the relative degree equals the state dimension), the internal stability is not guaranteed after output stabilization, as we point out by the following example.

Example 49 Consider the following input-output time-delay control system

$$\begin{aligned}\dot{x}_1(t) &= x_2(t) - 2u(t-1) \\ \dot{x}_2(t) &= x_1 + u(t) \\ y(t) &= x_1(t) + 2x_2(t-1),\end{aligned}\tag{2.2}$$

with $x(0) = (-2, 1)$ and $u(t) = 1$, for $t \leq 0$. The successive derivatives of the output $y(t)$ give

$$\dot{y}(t) = x_2(t) + 2x_1(t-1), \quad \text{and} \quad \ddot{y}(t) = x_1(t) + 2x_2(t-1) + u(t) - 4u(t-2), \quad \forall t \geq 0.$$

Notice that in this example the relative degree is equal to the dimension of the space. Suppose that we want to stay at $y(t) = 0$ for all $t \geq 0$. Hence u has to verify

$$u(t) - 4u(t-2) = 0, \quad \forall t \geq 0.\tag{2.3}$$

It follows from (2.3) that, over $[0, 2]$, the control u should be equal to 4. Similarly, we should have $u(t) = 4^2$ over $[2, 4]$. By repeating this reasoning, we find recursively that over the interval $[2n, 2n+2]$, the control u should be equal to 4^{n+1} . Then, there is no bounded u satisfying (2.3). In parallel, in this case the internal dynamics of (2.2) is clearly diverging as a linear dynamics generated by an unstable matrix (eigenvalues $\lambda_1 = 1$, $\lambda_2 = -1$) with piecewise-constant input.

In [80], we propose a solution for the problem of input-output linearisation for single-input single-output nonlinear time-varying delay systems. We develop sufficient conditions ensuring the internal stability in both cases: complete and partial input-output linearisation. The multi-input multi-output case is studied in [148] for the case of two-input two-output time-varying delay systems. Preliminary results leading to this result appeared in [78, 79]. We next describe the obtained results in the single-input single-output case.

2.3.1 Notations, definitions and problem statement

Definition 50 Let $\Delta > 0$ and $\tau : \mathbb{R} \mapsto (0, \Delta]$ be a sufficiently smooth function which is supposed to be known and satisfying $\dot{\tau} < 1$ over \mathbb{R}_+ . Consider the recursive relation

$$\tau_{i+1}(t) = \tau_i(t) - \tau \circ \tau_i(t), \quad \text{for } i \geq 0,$$

where $\tau_0(t) = t$. We denote by δ^i the time-delay operator that shifts the time from t to $\tau_i(t)$ and which is defined as

$$\delta^0 \alpha(t) = \alpha(t) \quad \text{and} \quad \delta^i \alpha(t) = \alpha(\tau_i(t)), \quad \text{for } i \geq 0,$$

where α is a function defined on an interval containing $[t - i\Delta, t]$. We introduce the δ and $\delta^{\geq i}$ operators which are defined, respectively, by

$$\begin{aligned}\delta\alpha(t) &= (\alpha(t), \delta^1\alpha(t), \dots, \delta^q\alpha(t)), \\ \delta^{\geq i}\alpha(t) &= (\delta^i\alpha(t), \dots, \delta^q\alpha(t)),\end{aligned}\tag{2.4}$$

where $0 \leq i < q$ and q is the maximal order of the delay operator acting on α . We introduce also the advance operator denoted by δ^{-i} that shifts the time from t to $\tau_i^{-1}(t)$ and which is defined by

$$\delta^{-i}\alpha(t) = \alpha(\tau_i^{-1}(t)), \quad \text{for } i \geq 0.$$

Similarly to the δ -operator, we define

$$\delta^{-}\alpha(t) = (\delta^{-1}\alpha(t), \dots, \delta^{-q}\alpha(t)).\tag{2.5}$$

Let $\tilde{f}, \tilde{g}_0, \tilde{g}_1 : \mathbb{R}_+ \times \mathbb{R}^{n(q+1)} \rightarrow \mathbb{R}^n$ and $\tilde{h} : \mathbb{R}_+ \times \mathbb{R}^{n(q+1)} \rightarrow \mathbb{R}$ be sufficiently smooth functions. The input-output linearisation of (2.1) is studied in the case where

$$f(t, x_t) = \tilde{f}(t, \delta x(t)), \quad g_0(t, x_t) = \tilde{g}_0(t, \delta x(t)), \quad g_1(t, x_t) = \tilde{g}_1(t, \delta x(t)), \quad \text{and} \quad h(t, x_t) = \tilde{h}(t, \delta x(t)).^1$$

We next define the Lie derivative for time-varying delay systems which is a generalisation of that presented in [41, 152] for constant-delay systems.

Definition 51 *Let $f : \mathbb{R}_+ \times \mathbb{R}^{n(q+1)} \rightarrow \mathbb{R}^n$ be a smooth vector field and $h : \mathbb{R}_+ \times \mathbb{R}^{n(q+1)} \rightarrow \mathbb{R}$ a real valued function. The Lie derivative of h along f at $(t, \delta x(t))$ is defined as*

$$L_f h(t, \delta x(t)) = \sum_{i=0}^q \frac{\partial h}{\partial \delta^i x} \dot{\tau}_i \delta^i f(t, \delta x(t)) + \frac{\partial h}{\partial t}(t, \delta x(t)).\tag{2.6}$$

Like for systems without delays, the input-output linearisation of time-delay systems can be accomplished by successive differentiation of the output until the input appears in the resulting derivative equation (the number of times that we need to differentiate will be called relative degree) and, then, by applying a feedback transformation for which the input-output map of the feedback modified systems is linear.

Definition 52 *We say that the problem of input-output linearisation is solvable for system (2.1) if the output h admits a finite relative degree ρ and if there exists a causal and bounded feedback u verifying*

$$a(\delta]u(t) = -L_f^\rho h(t, \delta x(t)) + \delta^j v(t), \quad \forall t \geq \tau_j^{-1}(t_0),\tag{2.7}$$

where $a(\delta]$ is the δ -polynomial given by

$$a(\delta] = a^0(t, \delta x(t))\delta^0 + \dots + a^{\rho q+1}(t, \delta x(t))\delta^{\rho q+1},\tag{2.8}$$

with

$$\begin{cases} a^0 &= \frac{L_f^k h}{\partial x} g_0(t, \delta x(t)), & a^{\rho q+1} &= \dot{\tau}_{\rho q} \frac{L_f^k h}{\partial \delta^{\rho q} x} \delta^{\rho q} g_1(t, \delta x(t)) \\ a^i &= \dot{\tau}_i \frac{\partial L_f^k h}{\partial \delta^i x} \delta^i g_0(t, \delta x(t)) + \dot{\tau}_{i-1} \frac{\partial L_f^k h}{\partial \delta^{i-1} x} \delta^{i-1} g_1(t, \delta x(t)), & \forall 1 \leq i \leq \rho q. \end{cases}$$

¹By abuse of notation, in the following we replace $\tilde{f}, \tilde{g}_0, \tilde{g}_1$ and \tilde{h} by f, g_0, g_1 and h , respectively.

The index j is the minimal degree of $a[\delta]$, i.e., the order of its first coefficient non identically zero, $t_0 = \tau_{\rho q}^{-1}(0)$ and v is the new control (assigned with respect to the properties that we want to achieve). If such u exists, then the feedback modified system satisfies:

$$y^{(\rho)}(t) = \delta^j v(t), \quad \forall t \geq t_0. \quad (2.9)$$

Moreover, the system is said input-output linearisable with delay if $j > 0$ (respectively, without delay if $j = 0$).

Remark 53 Note that in order to be able to compute the time-derivatives of $\delta^i x$, for $0 \leq i \leq \rho q$, equation (2.9) should be defined only for $t \geq t_0$.

The input-output linearisation usually leads to the existence of an unobservable part (called *zero-dynamics*) of system (2.1). Thus, a condition on the zero-dynamics is needed in order to guarantee the internal stability of the system. As stressed by Example 2.2, even in the case of a complete linearisation (i.e., $\rho = n$), we may also have an implicit relation between u and $\delta^i u$, for $j \leq i \leq \rho q$, (relation which is called internal input dynamics in the literature, see [57]). By consequence, two main problems may arise when constructing a feedback u from an equation of form (2.7). The first problem is the boundedness of u which comes from the zero-dynamics or the internal input dynamics or both at once. The second one is the causality of u that stems from the fact that the drift may involve more delays than the control vector fields or vice versa. In the next section we give sufficient conditions allowing to solve these problems. Under those conditions, we design new coordinates allowing the transformation of (a part of) system (2.1) into the ρ -th order linear input-output system

$$\begin{aligned} \dot{z}_i(t) &= z_{i+1}(t), \quad 1 \leq i \leq \rho - 1, \\ \dot{z}_\rho(t) &= \delta^j v(t), \end{aligned} \quad (2.10)$$

where $z_i = L_f^{i-1} h$, for $1 \leq i \leq \rho$.

2.3.2 Input-output linearisation theorem

Before stating the main theorem concerning the input-output linearisation of system (2.1), we introduce the following conditions:

(C1) - Relative degree: The output h has a finite relative degree $\rho \leq n$.

Condition **(C1)** requires that the relative degree of h is smaller or equal to n . It is clear that if this is not the case, system (2.1) is not input-output linearisable (in fact, a part of the system is not controllable).

Contrary to the cases of control systems without delays and constant-delay control systems, condition **(C1)** may not be sufficient to define a local change of coordinates and additional conditions may be needed. These are given by the next two conditions.

(C2) - New coordinates: There exists a smallest integer $0 \leq \ell \leq \rho q$ such that the matrix $\left(\frac{\partial L_f^k h}{\partial \delta^\ell x_i} \right)$, for $0 \leq k \leq \rho - 1$ and $1 \leq i \leq n$, is of full rank (equal to ρ) at any

$(t, \delta x(t)) \in \mathbb{R}_+ \times \mathbb{R}^{n(q(\rho+1)+1)}$.

Introduce the z -variables $z_i(t) = L_f^{i-1}h(t, \delta x(t))$, for $t \geq t_0$ and $1 \leq i \leq \rho$, and complete them by $n - \rho$ functions $\xi_i(t) = \phi_i(t, \delta x(t))$, for $\rho + 1 \leq i \leq n$, such that the Jacobian matrix $\left(\frac{\partial \Phi}{\partial \delta^\ell x}\right)$, where $\Phi = (h, \dots, L_f^{\rho-1}h, \phi_{\rho+1}, \dots, \phi_n)$, is of full rank (equal to n) at any $(t, \delta x(t)) \in \mathbb{R}_+ \times \mathbb{R}^{n(q(\rho+1)+1)}$.

(C3) - Causal and bounded inversion: There exist ξ -coordinates, a continuous function Ψ such that

$$\delta^\ell x(t) = \Psi(t, \delta z(t), \delta^- z(t), \delta \xi(t), \delta^- \xi(t), \delta^{\geq \ell+1} x(t)), \quad \forall t \geq t_0, \quad (2.11)$$

and a constant $\mu > 0$ such that if $\|\delta^{\geq \ell+1} x(t)\| < \mu$, then

$$\|\delta^\ell x(t)\| \leq \alpha_1 \|(\delta z(t), \delta^- z(t))\| + \alpha_2 \|(\delta \xi(t), \delta^- \xi(t))\| + \alpha_3 \|\delta^{\geq \ell+1} x(t)\|, \quad \forall t \geq t_0, \quad (2.12)$$

where $\alpha_1 > 0$, $\alpha_2 > 0$ and $0 < \alpha_3 < 1/(q(\rho + 1) - \ell)$.

Condition **(C2)**, together with **(C3)**, enables us to come back from the (z, ξ) -state space into the x -state space by expressing the delayed states $\delta^\ell x_i$, for a certain delay order $0 \leq \ell \leq \rho q$, as functions of the new state, their delays and advances, and possible delayed state $\delta^p x$, where $p \geq \ell + 1$ (hence the name "causal inversion") and to preserve (in the x -state space) properties (like boundedness) that hold in the (z, ξ) -state space.

(C4) - Causal feedback: The Lie derivative $L_f^\rho h$ and the coefficients of the δ -polynomial $a[\delta]$ verify

$$\frac{\partial L_f^\rho h}{\partial \delta^i x} \equiv 0 \text{ and } \frac{\partial a^k}{\partial \delta^i x} \equiv 0, \quad (2.13)$$

for $j \leq k \leq \rho q + 1$ and $0 \leq i \leq j - 1$ if $g_0 \neq 0$ (respectively, $0 \leq i \leq j - 2$ if $g_0 \equiv 0$).

Condition **(C4)** should be understood as follows: at an instant $t \geq t_0$, we have to assign to system (2.1) either $u(t)$, if $g_0 \neq 0$, or $\delta^1 u(t)$, if $g_0 \equiv 0$, and, in both cases, the construction of u is obtained from (2.7) by applying the advance operator δ^{-j} and thus shifting the coefficients of the δ -polynomial as well as $L_f^\rho h$ of order j in the future. In the case when $u(t)$ acts on the system (i.e., $g_0 \neq 0$), the causality condition (2.13) guarantees that the value of $u(t)$ depends only on the current and past values of the state; thus no causality problem can be produced when introducing in (2.1) the control u so obtained. In the case when only the delayed input appears (i.e., $g_0 \equiv 0$ and, of course, $g_1 \neq 0$), the causality condition provides that the value of $u(t)$, computed from the feedback equation, depends on the past, current and 1-advance values of the state. Again, when introducing in (2.1) the associated $\delta^1 u(t)$, no causality problem appears. Nevertheless, in this later case, a predictor is needed in order to compute the control as a function of the future values of the state. Finally, observe that when $j = 0$, there is no causality problem (and thus there is no condition to be checked).

(C5) - Bounded feedback: Let $v : [\tau_j(t_0), +\infty) \rightarrow \mathbb{R}$ be such that

$$\frac{-L_f^\rho h(t, \delta x(t)) + \delta^j v(t)}{a^j(\delta x(t), t)} \text{ is bounded over } [\tau_j^{-1}(t_0), +\infty) \quad (2.14)$$

and u be a solution of (2.7) for that v . Suppose that u is bounded over $[\tau_{\rho q+1-j}(t_0), t_0]$ and that there exists a constant $c > 1$ such that

$$\sup_{t \geq \tau_j^{-1}(t_0)} \left\| \frac{a^i(t, \delta x(t))}{a^j(t, \delta x(t))} \right\| \leq \frac{1}{c(\rho q + 1 - j)}, \quad \forall i > j. \quad (2.15)$$

Condition **(C5)** guarantees that the feedback u stays bounded when property (2.14) holds.

The following theorem gives only sufficient conditions for input-output linearisation of system (2.1).

Theorem 54 *Consider system (2.1) and suppose that conditions **(C1)**-**(C5)** are satisfied. Then, system (2.1) is input-output linearisable via the causal and bounded feedback transformation (2.7) and (a part of) it can be transformed into the ρ -th order linear input-output system (2.10). Moreover, if $\rho = n$, then the system is fully input-output linearisable with delay and if, in addition, $j = 0$, then the system is fully input-output linearisable without delay.*

2.3.3 Application: stabilization of time-varying delay systems

In addition to **(C1)**-**(C5)**, we suppose that the following condition is satisfied:

(C6) - Total causal inversion: We suppose that **(C3)** holds, with the ξ -coordinates and the function Ψ such that

$$\delta^\ell x(t) = \Psi(t, \delta z(t), \delta^- z(t), \delta \xi(t), \delta^- \xi(t)), \quad \forall t \geq t_0, \quad (2.16)$$

and that the dynamics of ξ do not contain advances in the ξ -states, i.e., $\dot{\xi}$ is of the form

$$\dot{\xi}(t) = G(t, \delta z(t), \delta^- z(t), \delta \xi(t), \delta v(t)). \quad (2.17)$$

In the case when $\rho < n$, by applying feedback (2.7) and introducing the new (z, ξ) -coordinates, system (2.1) is decomposed into two parts: a ρ -th order linear z -subsystem and a nonlinear ξ -subsystem (zero-dynamics) which may contain delayed and advanced states. Under assumptions **(C1)**-**(C6)**, system (2.1) can be transformed, for $t \geq t_0$, as follows:

$$\begin{cases} \dot{z}(t) = Az(t) + B\delta^j v(t), & \forall t \geq t_0 \\ \dot{\xi}(t) = G(t, \delta z(t), \delta^- z(t), \delta \xi(t), \delta v(t)), & \forall t \geq t_0 \\ y(t) = Cz(t), \end{cases} \quad (2.18)$$

where the matrices A , B and C are associated to form (2.10). Let

$$\delta^j v(t) = \begin{cases} K_1 z_1(t) + \dots + K_\rho z_\rho(t), & t \geq \tau_j^{-1}(t_0), \\ 0 & t_0 \leq t \leq \tau_j^{-1}(t_0), \end{cases} \quad (2.19)$$

where K_i , for $i = 1, \dots, \rho$, are chosen in such a way that $A + BK$ is Hurwitz, where $K = (K_1, \dots, K_\rho)$. In this case, the resulting closed loop subsystem

$$\dot{z}(t) = (A + BK)z(t), \quad (2.20)$$

is asymptotically stable. Therefore, under this choice of v , the state $z(t)$ tends asymptotically to zero when t tends to $+\infty$. Even if the input-output behavior can be stabilized by a feedback, the internal dynamics may be unstable and the global system cannot be stabilized.

The following proposition gives sufficient conditions guaranteeing the local asymptotic stability of the equilibrium point in x -coordinates.

Proposition 55 *Consider system (2.1) and suppose that conditions (C1)-(C6) are satisfied. Let u verifying equation (2.7) with v , given by (2.19), and such that the matrix $A + BK$ in (2.20) is Hurwitz. Suppose that the zero-dynamics (2.17) is uniformly input-to-state stable. Then, system (2.1) is locally asymptotically stable.*

Example 56 (stabilization of time-varying delay systems) *Consider the following input-output time-varying delay system*

$$\begin{aligned} \dot{x}(t) &= f(t, \delta x(t)) + g(t, \delta x(t))\delta u(t), \quad \forall t \geq 0, \\ x(\theta) &= \varphi(\theta), \quad \forall \theta \in [-2\Delta, 0], \\ y(t) &= x_3, \end{aligned} \quad (2.21)$$

where

$$f(t, \delta x(t)) = \begin{pmatrix} -4x_1 - \delta x_1 - \delta x_3^2 \\ \delta x_1 - \delta x_2 \\ x_2 + x_1\delta x_3 \end{pmatrix}, \quad g(t, \delta x(t)) = \begin{pmatrix} 0 \\ x_1^2 + 1 \\ 0 \end{pmatrix}. \quad (2.22)$$

One can easily verify that system (2.21) is input-output linearisable with delay. Then, by choosing the coordinates transformation

$$\begin{pmatrix} z_1 \\ z_2 \\ \xi \end{pmatrix} = \begin{pmatrix} x_3 \\ x_2 + x_1\delta x_3 \\ x_1 \end{pmatrix} \quad (2.23)$$

and the feedback

$$(1 + x_1^2)\delta u = -L_f^2 h(t, \delta x(t)) + v(t), \quad t \geq \tau_1^{-1}(0), \quad (2.24)$$

where

$$L_f^2 h(t, \delta x(t)) = (\delta x_1 - \delta x_2) + (-4x_1 - \delta x_1 - \delta x_3^2)\delta x_3 + \dot{\tau}_1 x_1 (\delta x_2 + \delta x_1 \delta^2 x_3), \quad (2.25)$$

system (2.21) can be equivalently (locally) written as

$$\begin{cases} \dot{z}(t) = \begin{pmatrix} 0 & 1 \\ 0 & 0 \end{pmatrix} z(t) + \begin{pmatrix} 0 \\ 1 \end{pmatrix} v(t) \\ \dot{\xi}(t) = -4\xi(t) - \delta\xi(t) - \delta z_1^2 \\ y(t) = z_1(t). \end{cases} \quad (2.26)$$

Let $\lambda_1 = -25$ and $\lambda_2 = -10$ and let v be as in equation (2.19). Under this choice of v , $z(t)$ converges asymptotically to zero. Thus, $w(t) = -\delta z_1^2(t)$, seen as an external exogenous input of the zero-dynamics

$$\dot{\xi}(t) = -4\xi(t) - \delta\xi(t) - w(t) \quad (2.27)$$

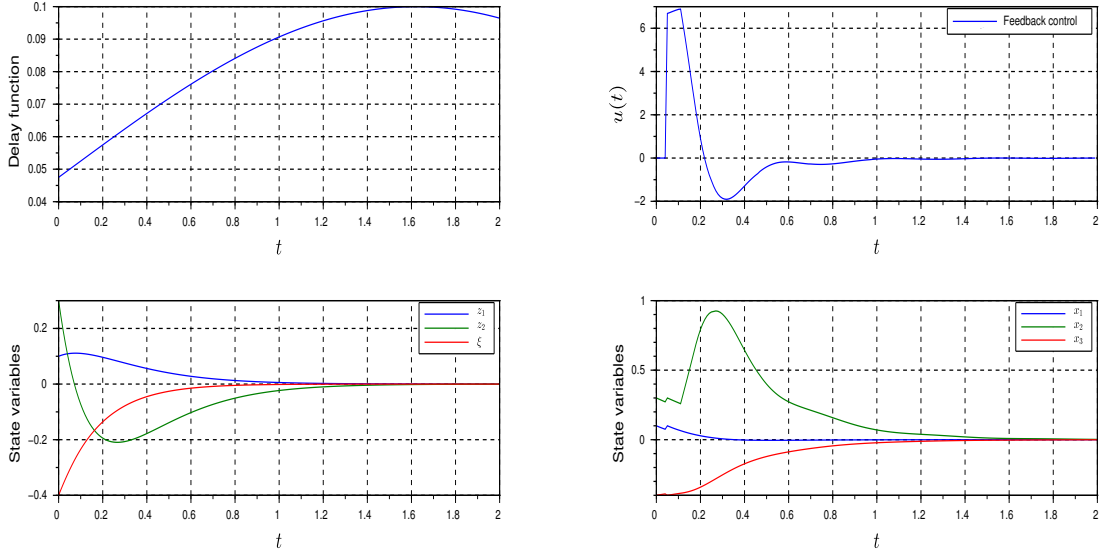

Figure 2.1: The behavior of system (2.1) in the (z, ξ) -coordinates (left) and in the x -coordinates (right).

is bounded over $[0, +\infty)$. knowing that system (2.27) is uniformly globally ISS (see, e.g., [53]), the local asymptotic stability of the overall system (2.26) is guaranteed by Proposition 55.

By Figure 2.1 (right), we illustrate the behavior of system (2.21) with initial conditions $x_1(\theta) = 0.1, x_2(\theta) = 0.3, x_3(\theta) = -0.4$, for $\theta \in [-2\Delta, 0]$, and variable delay function

$$\tau(t) = \frac{\Delta}{2}(1 + \sin(t - \frac{\Delta}{2})), \quad t \geq 0, \quad (2.28)$$

where $\Delta = 0.1$. Figure 2.1 (left) shows the behavior of system (2.21) in the (z, ξ) -coordinates. By Figure 2.1 (right), we illustrate the behavior of system (2.21) in the x -coordinates. Knowing that our system is partially linearisable with delay, then, as stated in Theorem 54, the feedback control u is calculated by prediction over the intervals $[0, \tau_1^{-1}(0)]$ and $[\tau_i^{-1}(0), \tau_{i+1}^{-1}(0)]$, for $i \geq 1$. We clearly observe this phenomena (through Figure 2.1 (right)) over the intervals $[0, \tau_1^{-1}(0)] = [0, \Delta/2]$ and $[\tau_1^{-1}(0), \tau_2^{-1}(0)]$.

2.4 Viable trajectories for nonconvex delay differential inclusions

Consider the control system described by the following retarded functional differential equation

$$\begin{cases} \dot{x}(t) = f(t, x_t, u(t)), & \text{a.e. } t \in [t_0, T], \\ u(t) \in U \subset \mathbb{R}^q, & \text{a.e. } t \in [t_0, T], \\ x_{t_0} = \varphi, \end{cases} \quad (2.29)$$

where $x(t) \in \mathbb{R}^n$; n is a positive integer; $\varphi \in \mathcal{C}([-\Delta, 0], \mathbb{R}^n)$ is the initial state; $u(\cdot)$ is a Lebesgue measurable function, f is a mapping from $[0, T] \times \mathcal{C}([-\Delta, 0], \mathbb{R}^n) \times U$ into \mathbb{R}^n , $0 \leq t_0 \leq T$. Here we consider that the trajectories of (2.29) are subject to the state constraint

$$x(t) \in K \quad \forall t \in [t_0, T], \quad (2.30)$$

where K is a closed subset of \mathbb{R}^n . Setting $F(t, x_t) = \bigcup_{u \in U} f(t, x_t, u)$, we replace the control system (2.29) by the differential inclusion

$$\begin{cases} \dot{x}(t) \in F(t, x_t) & a.e. t \in [t_0, T], \\ x_{t_0} = \varphi. \end{cases} \quad (2.31)$$

The viability theory [7] provides adequate mathematical tools to study the existence of feasible (or *viable*) solutions of system (2.31), i.e. solutions which satisfy the state constraint (2.30) for all $t \in [t_0, T]$. Thanks to this theory, a necessary and sufficient condition (linking the dynamics of system (2.29) to the geometry of the constraint set K) for the existence of viable solutions is known. Under some regularity assumptions on F , this condition was first given in [61]:

$$\forall t \in [0, T], \forall \psi \in \mathcal{C}([-\Delta, 0], \mathbb{R}^n) \text{ such that } \psi(0) \in K, F(t, \psi) \cap T_K(\psi(0)) \neq \emptyset, \quad (2.32)$$

where $T_K(\psi(0))$ is the contingent cone to K at $\psi(0)$. In the framework of this theory, convexity conditions are imposed on the set-valued map $F(t, \psi)$, i.e. for every $t \in [0, T]$ and every $\psi \in \mathcal{C}([-\Delta, 0], \mathbb{R}^n)$, $F(t, \psi)$ is a convex subset of \mathbb{R}^n . This convexity hypothesis may fail in some mathematical models and may be even difficult to verify. For this, in [43, 44], we relax this convexity hypothesis, by assuming, as a counterpart, stronger tangential condition and stronger regularity of F . This is given by the following relaxed *inward pointing condition*:

$$(IP_{rel}^\lambda) \begin{cases} \forall t \in [0, T], \forall \psi \in \mathcal{K}_\lambda, \forall v \in F(t, \psi) \\ \text{such that } \max_{n \in N_K^1(\psi(0))} \langle n, v \rangle \geq 0, \\ \exists w \in \text{Liminf}_{(s, \phi) \rightarrow (t, \psi)} \text{co } F(s, \phi) \\ \text{satisfying } \max_{n \in N_K^1(\psi(0))} \langle n, w - v \rangle < 0, \end{cases} \quad (2.33)$$

where Liminf denotes the Kuratowski lower set limit (see [7]), $N_K^1(x) := N_K(x) \cap S^{n-1}$, S^{n-1} is the unit sphere, $N_K(x)$ denotes the Clarke normal cone to K at x (see [27]), and the set \mathcal{K}_λ , for $\lambda > 0$, is given by

$$\mathcal{K}_\lambda := \{\psi \in \mathcal{C}([-\Delta, 0], \mathbb{R}^n) : \psi \text{ is } \lambda\text{-Lipschitz and } \psi(0) \in \partial K\}. \quad (2.34)$$

This condition relies on the possibility of directing a velocity into the interior of the constraint K whenever approaching the boundary of K . This condition is inspired from the literature of delay-free control systems treating the same problem (see, e.g., [45, 46, 47]). Condition (2.33) takes sometimes a simpler form depending on the regularity assumptions on F and the smoothness of the boundary ∂K (see, e.g., [47, 50, 43]).

2.4.1 Definitions and assumptions in use

We will use the following notion of solution:

Definition 57 Let $0 \leq t_0 \leq T$, $\Delta > 0$ and $\varphi \in \mathcal{C}([-\Delta, 0], \mathbb{R}^n)$. A function $x \in \mathcal{C}([t_0 - \Delta, T], \mathbb{R}^n)$ is called an F -trajectory, if $x(\cdot)$ is absolutely continuous on $[t_0, T]$ and verifies (2.31). An F -trajectory which verifies the state constraint (2.30) is called feasible F -trajectory. A trajectory associated to the relaxed differential inclusion

$$\begin{cases} \dot{x}(t) & \in \text{co}F(t, x_t), & \text{a.e. } t \in [t_0, T], \\ x_{t_0} & = \varphi \end{cases} \quad (2.35)$$

is called relaxed F -trajectory, and relaxed feasible F -trajectory if in addition (2.30) holds true.

Let $0 \leq t_0 \leq T$, $\Delta > 0$ and $F : [t_0, T] \times \mathcal{C}([-\Delta, 0], \mathbb{R}^n) \rightsquigarrow \mathbb{R}^n$ be a set-valued map with non-empty closed images. We will assume the following regularity conditions on F :

(H1) for every $\psi \in \mathcal{C}([-\Delta, 0], \mathbb{R}^n)$ the set-valued map $F(\cdot, \psi)$ is Lebesgue measurable;

(H2) the set-valued map $F(t, \cdot)$ is locally Lipschitz, i.e., $\forall R > 0$, $\exists \zeta_R(\cdot) \in L^1([t_0, T], \mathbb{R}^+)$ such that, for a.e. $t \in [t_0, T]$ and any $\varphi, \psi \in \mathcal{C}_R([-\Delta, 0], \mathbb{R}^n)$

$$F(t, \varphi) \subset F(t, \psi) + \zeta_R(t) \|\varphi - \psi\|_\infty B;$$

(H3) the set-valued map F has a sublinear growth, i.e. there exists $\sigma > 0$ such that, for a.e. $t \in [t_0, T]$ and any $\psi \in \mathcal{C}([-\Delta, 0], \mathbb{R}^n)$

$$F(t, \psi) \subset \sigma (1 + \|\psi\|_\infty) B;$$

(H4) for a given $\lambda > 0$, the set-valued map F is upper semicontinuous on $[t_0, T] \times \mathcal{K}_\lambda$, i.e. for all $t \in [t_0, T]$ and all $\varphi \in \mathcal{K}_\lambda$, we have $F(t, \varphi) \neq \emptyset$ and for every $\varepsilon > 0$ there exists $\delta > 0$ such that

$$F(s, \psi) \subset F(t, \varphi) + \varepsilon B \quad \forall (s, \psi) \in B(t, \delta) \times \mathcal{C}_\delta(\varphi)([-\Delta, 0], \mathbb{R}^n).$$

2.4.2 Main results

Assuming (IP_{rel}^λ) , in this section we give a relaxation result stating that the set of feasible trajectories is dense in the set of relaxed feasible ones. This is proved by using several preliminary results (see [43] for more details). The first one is an extension of the celebrated Filippov's theorem [40] to delay differential inclusions (see, e.g., [188] for differential inclusions in Banach spaces). In the case of finite dimensional differential inclusions, the theorem of Filippov theorem implies that, given a trajectory $x_1 : [0, T] \rightarrow \mathbb{R}^n$ of $\dot{x}(t) \in \mathcal{F}(t, x)$ with the set-valued map $\mathcal{F} : \mathbb{R}_+ \times \mathbb{R}^n \rightsquigarrow \mathbb{R}^n$ be measurable in t and k -Lipschitz in x , for any initial condition $x_2(0) \in \mathbb{R}^n$, there exists a trajectory x_2 starting from $x_2(0)$ such that $|x_1(t) - x_2(t)| \leq e^{kt} |x_1(0) - x_2(0)|$. The next theorem extends this property to delay differential inclusions.

Theorem 58 *Let $\beta > 0$ and $\delta_0 \geq 0$ and assume (H1)-(H2). Let $y \in \mathcal{C}([t_0 - \Delta, T], \mathbb{R}^n)$ be such that $y(\cdot)$ is absolutely continuous on $[t_0, T]$. Set $R = \max_{t \in [t_0 - \Delta, T]} \|y(t)\|$,*

$$\gamma_1(t) = d_{F(t, y_t)}(\dot{y}(t)), \quad \gamma_2(t) = \exp \left\{ \int_{t_0}^t \zeta_{R+\beta}(s) ds \right\}, \quad \gamma_3(t) = \gamma_2(t) \left(\delta_0 + \int_{t_0}^t \gamma_1(s) ds \right). \quad (2.36)$$

If $\gamma_3(T) < \beta$, then for all $\varphi \in \mathcal{C}([-\Delta, 0], \mathbb{R}^n)$ with $\|\varphi - y_{t_0}\|_\infty \leq \delta_0$, there exists $x \in \mathcal{C}([t_0 - \Delta, T], \mathbb{R}^n)$ such that $x(\cdot)$ is an F -trajectory and for all $t \in [t_0, T]$

$$\|x_t - y_t\|_\infty \leq \gamma_3(t)$$

and for almost every $t \in [t_0, T]$,

$$\|\dot{x}(t) - \dot{y}(t)\| \leq \zeta_{R+\beta}(t)\gamma_3(t) + \gamma_1(t).$$

The next theorem extends the so called Filippov-Ważewski's theorem [27] to delay differential inclusions. More precisely, we give a theorem which establishes the possibility of approximating any relaxed F -trajectory by an F -trajectory starting from the same initial condition.

Theorem 59 *Let $y(\cdot)$ be a relaxed F -trajectory. Assume (H1), (H2) and (H3). Then for every $\delta > 0$ there exists an F -trajectory $x(\cdot)$ satisfying $x_{t_0} = y_{t_0}$ and $\sup_{t \in [t_0, T]} \|x(t) - y(t)\| \leq \delta$.*

By the next two theorems we extend Theorem 58 and Theorem 59 to the case when the state variable x is constrained to the set K . This is in the same spirit of what is given in [46, 49] and [45] for finite- and infinite-dimensional differential inclusions, respectively.

The following theorem provides a NFT (for neighboring feasible trajectory) estimate on the distance of a given trajectory from the set of feasible trajectories.

Theorem 60 *Assume (H1)-(H3). Let $\Delta > 0$, $r_0 > 0$ and $\lambda_0 > 0$ and suppose that, for*

$$\lambda = \max\{\lambda_0, (1 + (1 + \lambda_0\tau + r_0)e^{\sigma T})\sigma\}, \quad (2.37)$$

assumptions (H4) and (IP_{rel}^λ) hold true. Then there exists a constant $C > 0$ such that for any $t_0 \in [0, T]$ and every relaxed F -trajectory $\hat{x}(\cdot)$ on $[t_0 - \Delta, T]$ with λ_0 -Lipschitz \hat{x}_{t_0} and $\hat{x}(t_0) \in K \cap B(0, r_0)$, and for any $\varepsilon_0 > 0$, we can find a relaxed feasible F -trajectory $x(\cdot)$ on $[t_0 - \Delta, T]$ satisfying $x_{t_0} = \hat{x}_{t_0}$, $x((t_0, T]) \subset \text{Int } K$ and

$$\|x_t - \hat{x}_t\|_\infty \leq C \left(\max_{t \in [t_0, T]} d_K(\hat{x}(t)) + \varepsilon_0 \right). \quad (2.38)$$

Theorem 60 and the constructive argument of [13, Proof of Lemma 5.2] imply the following Filippov-Ważewski's type theorem for constrained delay differential inclusions.

Theorem 61 *Under all the assumptions of Theorem 60, for any relaxed feasible F -trajectory $\bar{x}(\cdot)$ with λ_0 -Lipschitz \bar{x}_{t_0} and $\bar{x}(t_0) \in K \cap B(0, r_0)$, and any $\delta > 0$, there exists a feasible F -trajectory $x(\cdot)$ such that $x_{t_0} = \bar{x}_{t_0}$, $x((t_0, T]) \in \text{Int } K$ and $\|x_t - \bar{x}_t\|_\infty < \delta$ for all $t \in [t_0, T]$.*

2.4.3 Applicability of the obtained results

Two direct applications of the obtained relaxation theorems are discussed in the sequel.

Application in optimal control

The relaxation theorems obtained in Section 2.4.2 allow to show that the value function of an optimal control problem coincides with the value function of the relaxed one. Let $g : \mathbb{R}^n \rightarrow \mathbb{R}$ be a λ_1 -Lipschitz function. Suppose that the assumptions of Theorem 60 are satisfied. Let $\mathcal{S}_{[t_0, T]}^{\mathcal{K}_\lambda}(x_0)$ be the set of all solutions to (2.30)-(2.31), where $x_{t_0} = x_0$ and $x_0 \in \mathcal{K}_\lambda$, with

$$\mathcal{K}_\lambda := \{\psi \in \mathcal{C}([-\Delta, 0], \mathbb{R}^n) : \psi \text{ is } \lambda\text{-Lipschitz, } \psi(0) \in K\}.$$

Consider the Mayer optimal control problem

$$\min\{g(x(T)) : x(\cdot) \in \mathcal{S}_{[0, T]}^{\mathcal{K}_\lambda}(x_0)\}. \quad (2.39)$$

The value function, associated to problem (2.39),

$$V : [0, T] \times \mathcal{K}_\lambda \rightarrow \mathbb{R} \cup \{+\infty\},$$

is defined by

$$V(t_0, y_0) = \inf\{g(x(T)) : x(\cdot) \in \mathcal{S}_{[t_0, T]}^{\mathcal{K}_\lambda}(y_0)\} \quad (2.40)$$

with the convention that $V(t_0, y_0) = +\infty$ if $\mathcal{S}_{[t_0, T]}^{\mathcal{K}_\lambda}(y_0) = \emptyset$.

Thanks to Theorem 61, one can prove that V is equal to the value function of the relaxed Mayer problem, and thus any optimal solution to the Mayer problem is also optimal for the relaxed Mayer problem. Indeed, let us denote by \bar{V} the value function of the relaxed Mayer problem. Fix $(t_0, y_0) \in [0, T] \times \mathcal{K}_\lambda$. We have clearly $\bar{V}(t_0, y_0) \leq V(t_0, y_0)$. On other hand, for every $\varepsilon > 0$,

$$V(t_0, y_0) \leq g(x(T)) \leq g(\bar{x}(T)) + \lambda_1 \|x(T) - \bar{x}(T)\| \leq \bar{V}(t_0, y_0) + \varepsilon, \quad (2.41)$$

where $\bar{x}(\cdot)$ is a relaxed feasible trajectory verifying $\bar{V}(t_0, y_0) \geq g(\bar{x}(T)) - \varepsilon/2$ and $x(\cdot)$ an associated feasible trajectory satisfying (thanks to Theorem 61)

$$\|x_t - \bar{x}_t\|_\infty \leq \varepsilon/2\lambda_1, \quad \forall t \in [0, T]. \quad (2.42)$$

Being true for arbitrarily small ε , inequality (2.41) implies that $\bar{V}(t_0, y_0) = V(t_0, y_0)$.

In addition, Theorem 59 together with Theorem 60, allow to prove that V is Lipschitz on \mathcal{K}_λ . This latter property allows to characterise the optimal solutions of the Mayer problem by means of the relaxed differential inclusion (see [47, Theorem 5.3], for more details in the case of differential inclusions without delay).

Application to viability algorithms

When the viability condition fails to be fulfilled on the boundary of K , the largest subset of initial conditions (called *viability kernel*), starting from which at least one viable solution exists, is considered. In the case of delay-free control systems, viability algorithms providing

constructive methods for the computation of the viability kernel, have been developed (see, e.g., [48, 178]). Thanks to these algorithms, efficient numerical methods have been established (see, e.g., [177]) and used in order to find viability kernels for numerous examples coming from different fields (see, e.g., [8, 65, 181]). These algorithms are developed for set-valued maps with convex values. Two steps are needed to extend these numerical methods to non-convex delay differential inclusions: adapt the viability algorithms to convex differential inclusions with delay and obtain relaxation theorems under state constraints. This latter point is solved thanks to Theorem 61.

Example 62 *Here, we present an example that motivated us to develop relaxation theorems for delay differential inclusions. This concerns the management of urban pigeon population. In fact, urban pigeon population can reach high densities in cities and disturb the cohabitation with urban citizens. In view of some ecological considerations, this increased population may lead to a citizen dissatisfaction. In [65] we have proposed a model describing the evolution of such population, which is subject to some management strategies, and where the urban citizen tolerance formulated as a state constraint. The population dynamics is given by*

$$\begin{aligned}\dot{x}_1 &= n(x_2, u)x_2 - m_1(x_1, u)x_1 - p_1(x_1, u)x_1 \\ \dot{x}_2 &= -m_2(x_2, u)x_2 + p_1(x_1, u)x_1,\end{aligned}\tag{2.43}$$

where x_1 and x_2 denote the size of juvenile and adult pigeon populations and u is the control parameter relative to a management strategy (resource limitation, egg removal, sterilization, capturing). The function $n(\cdot)$ describes the reproduction of adult pigeon; $m_1(\cdot)$ and $m_2(\cdot)$ describe the mortality of juvenile and adult pigeons. The function $p_1(\cdot)$ represents the transfer rate from juvenile to adult class. The urban citizen tolerance is described through the following state constraints set

$$K = \begin{cases} \underline{M} \leq x_1 + x_2 \leq \overline{M}, & \forall t \geq 0, \\ x_1 \geq 0, \quad x_2 \geq 0, & \forall t \geq 0, \end{cases}\tag{2.44}$$

where \underline{M} and \overline{M} represent the lower (the presence of some pigeons) and upper (not too many pigeons) limits. Thanks to the viability theory, viability kernels describing the existence of efficient management strategies are calculated (see Section 3.5 and see [65] for further details). The model (2.43) is not sufficiently precise, because it does not take into account the fact that juvenile pigeons start to reproduce only after becoming adults. This leads naturally to a model with time-delay that we describe next. Actually, the transfer from juvenile to adult class is modeled as a function with a delay involving the adult pigeons, taking into account the following observation: the juveniles which are born a time $t - \Delta$ and survive to time t exit to adult pigeon class, where Δ is the time from birth to maturity. This can be formulated by the following equations

$$\begin{aligned}\dot{x}_1 &= n(x_2, u)x_2 - m_1(x_1, u)x_1 - p_1(x_1, u)x_1(t - \Delta) \\ \dot{x}_2 &= -m_2(x_2, u)x_2 + p_1(x_1, u)x_1(t - \Delta).\end{aligned}\tag{2.45}$$

Let $x = (x_1, x_2)$ and $y = (y_1, y_2) \in \mathbb{R}^2$. System (2.45) can be written in the form of (2.31), where the set-valued map $F : \mathcal{C}([-\Delta, 0], \mathbb{R}^2) \rightarrow \mathbb{R}^2$ is given, for $\phi = (\phi_1, \phi_2) \in \mathcal{C}([-\Delta, 0], \mathbb{R}^2)$, by

$$F(\phi) = \bigcup_{u \in U} \begin{pmatrix} n(\phi_2(0), u)\phi_2(0) - m_1(\phi_1(0), u)\phi_1(0) - p_2(\phi_1(0), u)\phi_1(-\Delta) \\ -m_2(\phi_2(0), u)\phi_2(0) + p_2(\phi_1(0), u)\phi_1(-\Delta) \end{pmatrix}.$$

As underlined in section 2.4.3, the viability algorithms are conceived for convex set-valued maps. In the case of (2.45), in general, F is not convex. If $n(\cdot)$, $m_1(\cdot)$ and $m_2(\cdot)$ are sufficiently regular then F fulfills the assumption of Theorem 61. Thus, if condition $(IP_{e_q}^\lambda)$ holds true on the boundary of K , Theorem 61 guarantees the existence of feasible trajectories for (2.45), approximating a feasible relaxed trajectory of the convexified problem.

Chapter 3

Application in population dynamics

3.1 Abstract

In this chapter we present the contributions obtained in modelling and analysis of population dynamics. These contributions are obtained in collaboration with Isabelle ALVAREZ, Antoine CHAILLET, Jean-Pierre BARBOT, Jérôme HARMAND, Alain RAPAPORT, Elie DESMOND-LE QUÉMÉNER, Elena PANTELEY, Anne-Caroline PRÉVOT, Suhan SENOVA and William PASILLAS-LÉPINE [65, 66, 67, 68, 69, 72, 81, 82, 83, 87, 154, 170].

3.2 Introduction

The dynamics of a biological population depends on several interacting external variables, such as the quantity of resources (food, feed input), environmental conditions (pollution, predators, temperature) and human actions. These systems can be considered as composed of state variables (whose evolution is a function of other variables in the system), constraints, and objectives to be achieved. Ordinary differential equations can be used to describe a large class of these systems [168]. For example, the dynamic of microorganisms in bioreactors [92, 183], the progression of chemical reactions [153], and many other population dynamics can be represented by ordinary differential equations. However, for particular class of population dynamics, a time-delay could be considered in some variable of the system, in order to build more realistic model. This is the case, for example, when dealing with neural population dynamics where we have to consider the delay involved in synaptic transmissions; when we study some neurological disease like Parkinson's disease, the delay of electrical connections between neurones cannot be neglected to describe some pathological oscillations [147]. Also, it is often interesting to involve systems that associate to an initial state different possible evolutions depending on uncertainties and variable parameters.

In this chapter, we present contributions in modelling and analysis in three different domain of population dynamics. The first is about microbial dynamics in bioreactors where ODEs are used to model different interesting phenomena in this context. The second contribution concerns the analysis of a neural population dynamics which describe the evolution of the Parkinson's disease. This later is modeled by a system of delay differential equations. The third contribution deals with the problem of managing of urban pigeon population using some possible actions that make it reach a density target with respect to socio-ecological constraints. The mathematical viability theory, which provides a framework to study compatibility between dynamics and state constraints, is employed in this last problem.

3.3 Mathematical models and problems related to microbial dynamics in bioreactors

The chemostat is an experimental device invented simultaneously in the fiftens by Monod [142] and Novick & Szilard [151]. It permits to study the microbial growth on a limiting resource in a physiological steady state under constant environmental conditions. If s and x denote respectively the substrate and biomass concentrations in a culture vessel of volume V , their time evolution are modeled by the following system of ordinary differential equations

$$\begin{cases} \dot{s} &= -\frac{1}{Y}\mu(s)x + \frac{Q}{V}(S_{in} - s), \\ \dot{x} &= \mu(s)x - \frac{Q}{V}x \end{cases} \quad (3.1)$$

where Y is the yield coefficient, μ is the growth function describing the rate of growth of microorganisms, Q is the input flow and S_{in} is the input concentration of substrate. The model given by (3.1) supposes that the microorganisms introduced in the vessel are of a single species and that the substrate is the single limiting resource for growth. Also this model supposes that the vessel is perfectly mixed and its volume is constant (i.e. the input and output flows are both equal to Q).

3.3.1 Microbial dynamics within interconnected bioreactors

The chemostat has been used as a reference model in different branches like in microbiology, microbial ecology or biotechnological industries such as the wastewater treatment [60, 164]. However, in many applications, the assumption of “perfectly mixed” is, in general, too restrictive. For this reason, the idea of interconnected chemostats was introduced in the literature. Instead of considering a single perfectly mixed volume, the idea is to consider a set of interconnected perfectly mixed sub-bioreactors of identical total volume. This was firstly studied in [120] to represent some spatial gradient by considering a set of chemostats interconnected in series. The influence of the topology of a network of chemostats on the overall dynamics has been sparsely investigated in the literature. In [87, 170] we have shown how a simple consideration of two interconnected habitats can lead to non-intuitive behaviors in the microbial dynamics. Here, we recall some non-intuitive results related to the performance of a chemostat under some particular spatialization considerations.

Case of Monod growth type function

Assume that the growth function μ is given by the following well known Monod function (see Figure 3.1):

$$\mu(s) = \mu_{max} \frac{s}{k_s + s}, \quad (3.2)$$

where μ_{max} denotes the maximum growth rate and k_s the half-velocity concentration. For convenience we denote the dilution rate $D = \frac{Q}{V}$ and define the break-even concentration λ given by:

$$\lambda(D) = \begin{cases} \text{the solution of } \mu(s) = D & \text{when } \max_{s \geq 0} \mu(s) > D \\ +\infty & \text{otherwise.} \end{cases} \quad (3.3)$$

System (3.1) admits at most two equilibrium points: the wash-out equilibrium $E_0 = (S_{in}, 0)$ and

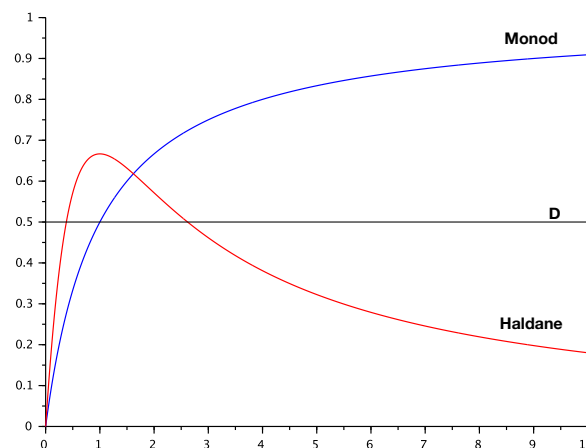

Figure 3.1: Graphs of Monod and Haldane functions.

the nontrivial positive equilibrium $E_1 = (\lambda(D), S_{in} - \lambda(D))$ which exists only when $\lambda(D) < S_{in}$. Under this last condition, E_0 is unstable and any solution with $x(0) > 0$ converges

asymptotically to E_1 . On the contrary, when $\lambda(D) \geq S_{in}$ the wash-out equilibrium E_0 is globally asymptotically stable. Therefore, for a given dilution rate D such that $\mu(S_{in}) < D$, the output substrate concentration at steady state is independent of the input concentration S_{in} ; this property is no longer satisfied when a spatial heterogeneity is considered. This is a first basic property underlying the effect of spatialization in the chemostat.

In order to thoroughly study the role of spatialization in the chemostat, we fix both the total hydric volume and the input flow and study the performance of the input-output map at steady-state. The performance here is measured by the level of substrate that is degraded by the system and collected at the output. We draw precise comparisons between the three configurations: perfectly mixed, serial and parallel (with diffusion rate) with the same total hydric volume and flow rate (see Figure 3.2). This set of configurations is far from being exhaustive, but it gives an idea on how a spatial structure can modify the input-output map, and what are the key parameters.

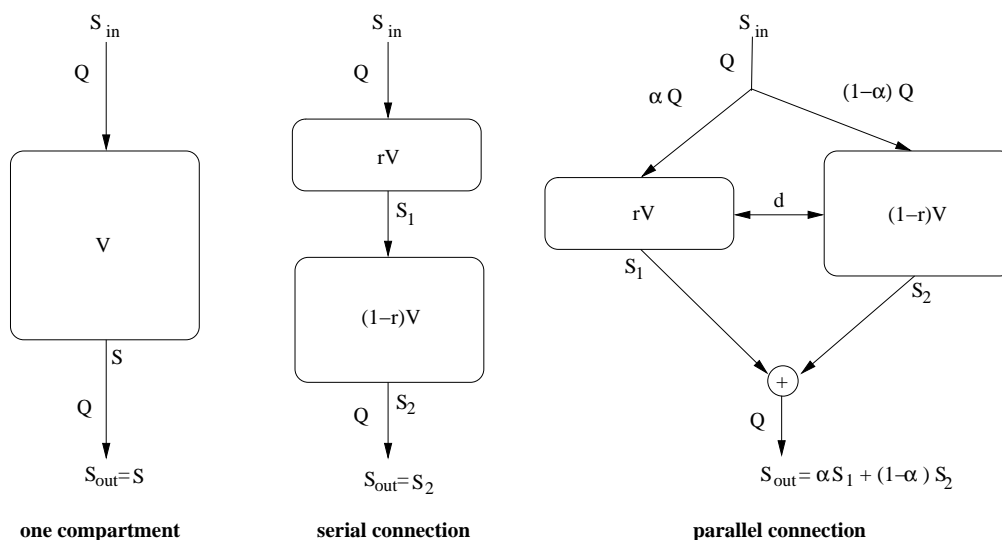

Figure 3.2: The set of configurations under investigation.

We have the following result.

Proposition 63 *For a given input flow rate Q and volume V , there exists a threshold $\bar{S}_{in} > 0$ such that the smallest output concentration s_{out}^* is reached for a serial configuration when $S_{in} > \bar{S}_{in}$, and for a parallel configuration when $S_{in} < \bar{S}_{in}$. Moreover, in this last case, the map $d \mapsto s_{out}^*(d)$ admits a unique minimum for some $d^* < +\infty$. Furthermore, there exists another threshold $\underline{S}_{in} < \bar{S}_{in}$ such that $d^* = 0$ for $S_{in} < \underline{S}_{in}$ and $d^* > 0$ for $S_{in} \in (\underline{S}_{in}, \bar{S}_{in})$.*

The result formulated by Proposition 63 has been proved in [87, 63]. We illustrate this result for a linear growth function with total volume V and input flow rate Q such that $\lambda(D) = 1$. For the single compartment configuration, the output concentration at steady state is thus equal to 1 and the threshold \bar{S}_{in} is equal to 2 in this case. The output concentration at steady state s_{out}^* has been plotted for different values of S_{in} as function of the parameters of the serial or parallel

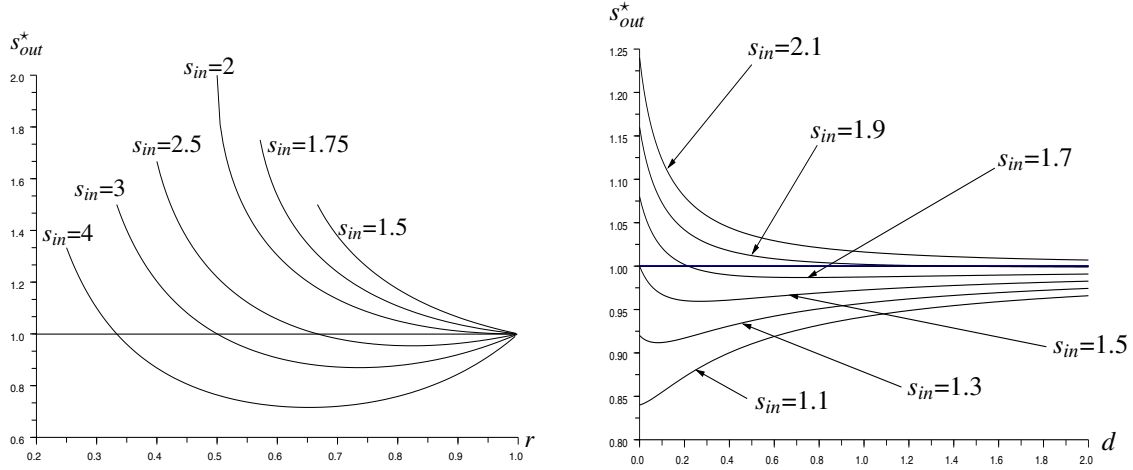

Figure 3.3: Output performances of the serial and parallel configurations.

configurations. One can observe (see Figure 3.3) that for any value of S_{in} , there always exists a serial or parallel configuration such that $s_{out}^* < 1$ (that is consequently better than having a single compartment). When S_{in} is above the threshold \bar{S}_{in} , the parallel configurations have always $s_{out}^* > 1$ and there exist values of r such that the serial configuration has $s_{out}^* < 1$. While, for S_{in} below the threshold, the serial configuration has $s_{out}^* > 1$, and there exist parameter values of d such that the parallel configuration has $s_{out}^* < 1$. Moreover, one can see that for values of S_{in} under the threshold but not too low, the smallest value of s_{out}^* is obtained for a positive value of the diffusion parameter d .

Case of Haldane growth type function

When microbial growth can be inhibited by large concentrations of nutrient, the following non-monotonic response function, well known under Haldane function (see Figure 3.1):

$$\mu(s) = \bar{\mu} \frac{s}{k_s + s + s^2/k_i}, \quad (3.4)$$

where k_i is related to the growth inhibition, can be used to model the growth inhibition phenomenon [5]. Non-monotonic response functions occur in predator-prey models, for instance, when the predation decreases due to the ability of the prey to better defend when their population get larger. In this case, the mathematical analysis of the chemostat model (3.1) reveals three possible behaviors of the dynamics, depending on the input parameters (D, S_{in}) . Let us before define the following interval

$$\Lambda(D) = \{s > 0 : \mu(s) > D\},$$

which plays an important role in the determination of the equilibria of the system. The set $\Lambda(D)$ is either empty or equal to the open interval $(\lambda_-(D), \lambda_+(D))$, for some $\lambda_+(D) \geq \lambda_-(D) > 0$. We distinguish three different cases:

- i) If $\Lambda(D) = \emptyset$ or $S_{in} \leq \lambda_-(D)$ then the wash-out $E_0 = (S_{in}, 0)$ is the unique equilibrium, which is globally asymptotically stable;
- ii) If $S_{in} > \lambda_+(D)$, system (3.1) has three non-negative equilibria $E_0 = (S_{in}, 0)$, $E_- = (\lambda_-(D), S_{in} - \lambda_-(D))$ and $E_+ = (\lambda_+(D), S_{in} - \lambda_+(D))$. Only E_- and E_0 are attracting, and the dynamics is bi-stable;
- iii) If $S_{in} \in (\lambda_-(D), \lambda_+(D))$, system (3.1) has two non-negative equilibria $E_0 = (S_{in}, 0)$ and $E_- = (\lambda_-(D), S_{in} - \lambda_-(D))$. The equilibrium point E_- is globally attracting on the positive quadrant.

Notice that in case ii), the qualitative behavior of the growth can change radically depending on the initial condition.

In [170] we introduce the buffered configuration type (see Figure 3.4). This configuration plays an important role making the chemostat dynamics globally asymptotically stable.

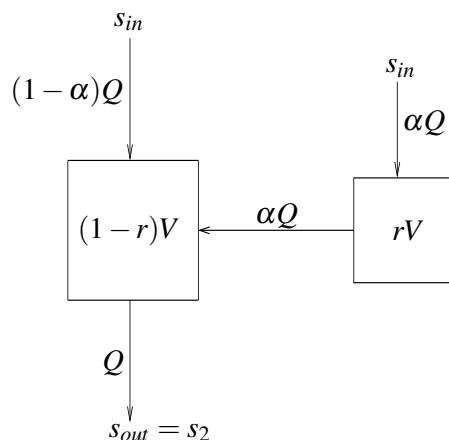

Figure 3.4: The buffered chemostat.

This is formulated by the following result proved in [170].

Proposition 64 *Assume that $S_{in} > \lambda_+(D)$. For any $\alpha \in (0, 1)$ such that $\alpha D < \mu(S_{in})$, there exists $r \in (0, 1)$ such that the buffered chemostat configuration has a unique positive equilibrium. Moreover, starting from any initial condition with positive biomass concentration in the (r, α) tank, the solution converges asymptotically to this equilibrium.*

Proposition 64 shows that there exist buffered configurations such that the overall dynamics has an unique globally asymptotically stable positive equilibrium, even when perfectly mixed, serial or parallel configuration lead to the extinction of the biomass (see [170] for more details). Furthermore, Proposition 64 shows that in absence of initial biomass in the main tank, a species seeded in the buffer can invade and persist in the main tank.

Ecological discussion and technological interpretation of Propositions 63 and 64

The set of the considered configurations is far to be exhaustive, being limited to only two compartments, but it reveals important messages in terms of input-output performances of

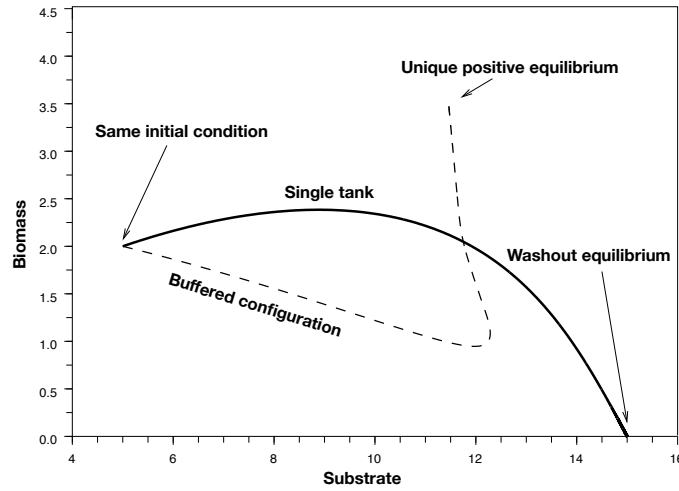

Figure 3.5: Comparison between the behavior of perfectly mixed tank and the buffered configuration for $\mu(s) = \frac{10s}{1+s+s^2}$, $S_{in} = 15$, $r = 0.8$ and $\alpha = 0.32$.

an ecosystem. For example, it always exist spatial distributions which improve the substrate conversion compared to a single perfectly mixed volume. For rich environments (i.e. for large value of S_{in}), a serial distribution can be the most efficient, while for a poor environment a parallel distribution can be the best, and a moderate diffusion could even improve it. In presence of inhibition, a simple spatial structure like the buffered can explain the persistence of a species in an environment that is unfavorable if it was homogeneous.

A typical field of biotechnological applications of Proposition 64 is the wastewater treatment with microorganisms [60]. For such industries, a usual objective is to reduce the output concentration of substrate that is pumped out from the main tank. Typically, a species that is selected to be efficient for low nutrient concentrations could present a growth inhibition for large concentrations (its growth rate being thus non-monotonic). Usually, the input concentration S_{in} is imposed by the industrial discharge and cannot be changed, but the flow rate Q can be manipulated. During the initial stage of continuous stirred bioreactors (that are supposed to be perfectly mixed), the biomass concentration is most often low (and the substrate concentration large). This means that there exists a risk that the initial state belongs to the attraction basin of the wash-out equilibrium if one immediately applies the nominal flow rate Q . In this case the process needs to be monitoring with the help of an automatic control that makes the flow rate Q decreasing in case of deviation toward the wash-out. But such a solution requires an upstream storage capacity when reducing the nominal flow rate, that could be costly. Keeping a constant input flow rate is thus preferable. An alternative is to oversize the volume of the tank so that there is no longer bi-stability and no need for a controller. Compared to these two solutions, a design with a main tank and a buffer (that guarantees a unique positive and globally asymptotically stable equilibrium) presents three principal advantages: 1) it does not require to oversize the main tank, 2) it does not require any implementation of a controller, and 3) it allows to seed the initial biomass in the buffer tank only. Knowing its biotechnological application, the result given by Proposition 64 has been patented by the INRAE.

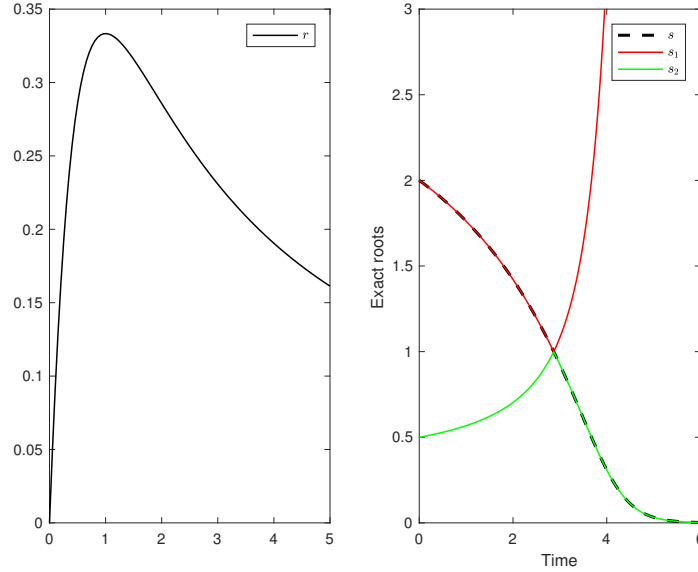

Figure 3.6: Left: the function μ given by (3.4) with $\bar{\mu} = k_s = k_i = 1$. Right: the exact roots of $\mu(s) = \dot{x}/x$.

3.3.2 Observers for batch processes with Haldane growth function

In this section we present a contribution in the domain of observation of singularly observable systems with application to microbial dynamics in batch culture, i.e., in bioprocesses modeled by (3.1) with $Q = 0$. The problem is the reconstruction of the substrate concentration when only the biomass concentration is measured. In fact, when the microbial growth rate function is non-monotonic, for example given by (3.4), the observability problem becomes particularly difficult. Indeed, in this case, a singularity observability problem appears in the state space. More precisely over the set $\{(x, s) \in \mathbb{R}_+^2 : \mu(s) = \dot{x}/x\}$, where the information based on the first derivative gives two solutions s_1 and s_2 , and the choice between need additional informations. However, since the system is differentially observable with an injectivity index $m = 3$, the problem of construction of an observer for (3.1) in the original coordinates, can be overcome according to the following classical approach: 1) transforme the original system into the so called *observability form* [56], 2) determine an observer in this canonical form, and then 3) expresse the estimation back in the original coordinates. Knowing that in general this change of coordinates is defined through an immersion in higher dimension space, and not simply a diffeomorphism, this approach has been widely investigated in the literature (see, e.g., [12]). The principal difficulty by following this approach lies in the construction of an embedding and a Lipschitzian extension of the dynamics (3.1) outside the set of its forward orbits. This is nicely discussed and studied in [171], where a constructive method is given for general class of systems.

The multi-observers approach

To deal with the problem of immersion in higher dimension space, we have proposed a new approach in [68] which concerns the particular class of systems defined on a subset of \mathbb{R}^2

$$\dot{x} = f_1(x, s), \quad (3.5)$$

$$\dot{s} = f_2(x, s), \quad (3.6)$$

where f_1 is a rational function and f_2 is a sufficiently smooth function, along with the observation $y = h(x, s) \equiv x$. Instead of a single observer in higher dimension, we propose a set of observers in the original coordinates and a test function which can discriminate between the observers the one that will give the right estimate. This test function is based on higher derivatives of the observation. More precisely, starting from equation (3.5) we build the following set of estimators

$$\begin{cases} \frac{\partial F_\varepsilon}{\partial s}(z, \hat{s}_\varepsilon) \dot{\hat{s}}_\varepsilon = -\frac{\partial F_\varepsilon}{\partial z}(z, \hat{s}_\varepsilon) \dot{z} - k F_\varepsilon(z, \hat{s}_\varepsilon), \\ \hat{s}_\varepsilon(0) \in \mathbb{C} \setminus \mathbb{R}, \end{cases} \quad (3.7)$$

with $z = (y, \dot{y})$ and $\varepsilon, k > 0$. The function $F_\varepsilon : \mathbb{R}^2 \times \mathbb{C} \rightarrow \mathbb{C}$, is defined by

$$F_\varepsilon(z, \sigma) := N(z_1, \sigma) - z_2 D(z_1, \sigma) - \varepsilon i, \quad (3.8)$$

where N and D are the numerator and denominator of f_1 , respectively. For $t \geq 0$, $F_\varepsilon(z(t), \cdot)$ admits p -distinct time-varying complex roots, $s_{\varepsilon,1}(z(t)), \dots, s_{\varepsilon,p}(z(t))$ which vary continuously with respect to time, where $p = \max\{\deg(N), \deg(D)\}$. Knowing that the roots of (3.8) are arbitrarily close to those of $F_0(z(t), \cdot)$ for arbitrarily small values of ε (see, e.g., [146]), they will be used to closely track the different time-varying solutions of $z_2(t) = f_1(z_1(t), \cdot)$, for all $t \geq 0$. The role of $\varepsilon > 0$ is essential to avoid singularities brought by multiple roots.

After estimating the different time-varying solutions $\hat{s}_1(t), \dots, \hat{s}_p(t)$ of $z_2(t) = f_1(z_1(t), \cdot)$ and using the vector $\bar{z} = (y, \dot{y}, \dots, y^{(m)})$ of the successive derivatives of y (m is the observability index which is supposed finite) the following test function

$$\mathcal{T}(\bar{z}, \hat{s}) := \left\| \left(\bar{z}_2 - L_f h(\bar{z}_1, \hat{s}), \dots, \bar{z}_m - L_f^{m-1} h(\bar{z}_1, \hat{s}) \right) \right\|_M, \quad (3.9)$$

for some real symmetric positive definite matrix M , will be used to provide at each $t \geq 0$ an estimation $\hat{s}(t)$ of $s(t)$ among $\hat{s}_1(t), \dots, \hat{s}_p(t)$. In fact, we choose $\hat{s}(t) = \hat{s}_{i^*(t)}(t)$ for which $\hat{s}_{i^*(t)}(t)$ minimises the function $\mathcal{T}(\bar{z}(t), \hat{s}_i(t))$ among the estimators $\hat{s}_1(t), \dots, \hat{s}_p(t)$, for $t \geq 0$.

This multi-observers approach requires the following three assumptions. Let \mathcal{D} be a relatively compact subset of \mathbb{R}^2 not containing the poles of f_1 and positively invariant by the dynamics (3.5)-(3.6).

Assumption 65 *The observability map $(y, s) \xrightarrow{\Phi} (h(y, s), L_f h(y, s), \dots, L_f^{m-1} h(y, s))$ defines an injective immersion on \mathcal{D} , for some $m \geq 2$.*

Assumption 66 *For all $z \in \Phi_1(\mathcal{D}) \times \Phi_2(\mathcal{D})$, the polynomial $\frac{\partial F_0}{\partial s}(z, \sigma)$ does not admit complex roots.*

Assumption 67 For every $\varepsilon > 0$ the number of roots of $F_\varepsilon(z(t), \cdot)$ is constant and equal to p over \mathbb{R}_+ .

Under Assumption 66 the dynamics (3.7) can be defined explicitly. The following theorem is proved in [68].

Theorem 68 Suppose that Assumption 65, Assumption 66 and Assumption 67 hold. Then, for every $\delta > 0$ and every $i \in \{1, \dots, p\}$, there exists $\bar{\varepsilon} > 0$ such that, for every $\varepsilon \in (0, \bar{\varepsilon})$, the solution of (3.7) starting from $s_{\varepsilon,i}(z(0))$ satisfies the following inequality

$$\sup_{t \geq 0} |\hat{s}_\varepsilon(t) - s_i(z(t))| < \delta. \quad (3.10)$$

Theorem 1 assumes the perfect knowledge of vector $z(\cdot)$, that is the first two components of vector $\bar{z}(\cdot)$. In practice, one can use a numerical differentiator to estimate $z(\cdot)$ allowing a short time interval $[0, \eta]$ for the differentiator to converge and then one can use the roots tracking method that we propose from time η (i.e. all the roots are computed once at time η and then tracked over time by continuation).

Application to the batch process

In order to show the applicability of our multi-observers approach in the case of batch culture process, we consider system (3.5)-(3.6) with $f_1(x, s) = \mu(s)x$ and $f_2(x, s) = -\mu(s)x$ where μ is given by (3.4), with $\bar{\mu} = k_s = k_i = 1$. We suppose that we measure the biomass concentration x . It is easy to check in this case that the positive orthant is invariant by (3.5)-(3.6) and that the poles of μ does not belong there. The construction of s requires to solve the equation $\mu(s) = \dot{y}/y$, whose real solutions number varies in times, as one can observe from Figure 3.6-right. In order to construct the solutions of $\mu(s) = \dot{y}/y$, we consider its corresponding perturbed dynamics with

$$F_\varepsilon(z, \sigma) = 6z_1\sigma(\sigma^2 - 2.5\sigma + 2) - (\sigma^2 - \sigma + 3)z_2 - \varepsilon i. \quad (3.11)$$

We simulate dynamics (3.7) starting from the roots of $F_\varepsilon(z(0), \cdot)$. The two solutions $\hat{s}_{\varepsilon,1}(t)$ and $\hat{s}_{\varepsilon,2}(t)$ (which are always complex) will follow the roots of $F_\varepsilon(z(t), \cdot)$, for $t \geq 0$. The perturbation parameter ε plays a crucial role in separating neighboring solutions. This is particularly interesting in the case of measurement noise, where a sufficiently large ε allows the separation of the disturbed estimators $\hat{s}_{\varepsilon,i}(\cdot)$ around the singularities. Of course, a large value for ε acts against the precision of the estimator (3.7), and this should be fixed depending on the amplitude of the noise. In order to construct an estimation of $s(t)$, we have to determine among this two solutions which one is the right one, at any $t \geq 0$. For this, we choose the solution $\hat{s}_\varepsilon(t) = \hat{s}_{\varepsilon,i(t)}(t)$ for which $\Re(\hat{s}_{\varepsilon,i(t)}(t))$ minimizes the function $\mathcal{T}(\bar{z}(t), \Re(\hat{s}_{\varepsilon,i}(t)))$ among the set $\{\hat{s}_{\varepsilon,i}(t)\}_{i=1,2}$. The choice of the norm in (3.9) plays an important role when dealing with numerical differentiators, especially when measurement noise is considered. In fact, when some a priori knowledge on the nature of the noise is known, one could determine numerically a covariance matrix of the estimation error of the time derivatives of the observation, whose inverse can be chosen for the norm in (3.9). Concerning the assumptions, one can easily verify that Assumption 65 holds, using the fact that the map Φ , with $m = 3$, is injective. Observe also that Assumption 66 and Assumption 67 hold in this case. By Figure 3.7 we show the real part

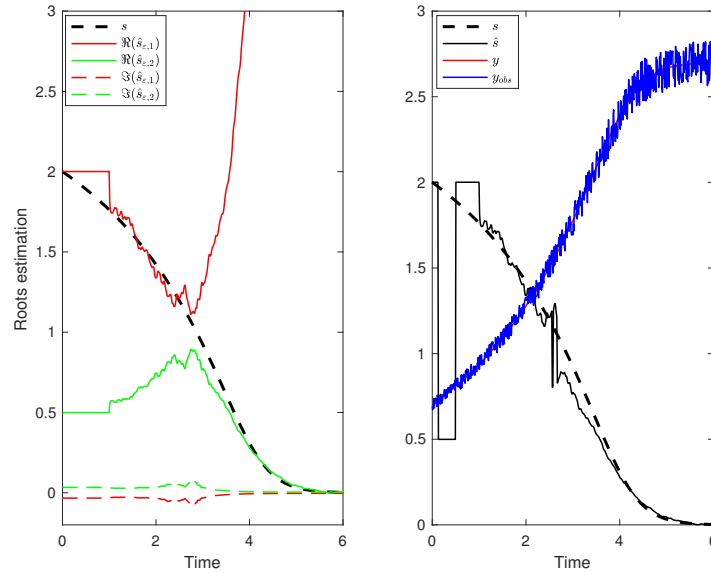

Figure 3.7: Left: illustration of the estimated roots of (3.11) with $\varepsilon = 0.01$. Right: the exact solution together with the constructed one. Case of estimated \bar{z} with noise measurement proportional up to 5% of y .

of the estimated roots (left) together with the estimation of s (right) where ε is fixed at 0.01, and a noise measurement proportional up to 5% of y is considered. The matrix $M = \text{diag}(1, 0.1)$ is chosen to define the test function in (3.9). It is worth noting that the estimators become quite sensitive to noise near the equilibrium point. This is explained by the fact that the exact derivatives become practically null close to the equilibrium point (this difficulty was already present with the approach proposed in [171]).

3.3.3 Optimal control of an electro-fermentation process within a batch Culture

The electro-fermentation is a novel process that consists in electrochemically controlling microbial fermentative metabolism with electrodes [144] (see the Figure 3.8). This is a revolutionary process for biotechnological and industrial applications. For example, it could be used to “better” valorize the glycerol, which is a major by-product of the biodiesel production from vegetable oil, through its “controlled” transformation to molecules for green chemistry such as 1,3-propanediol (the electro-fermentation improves of 10% the production of 1,3-propanediol, comparing to the classical fermentation [145]). Experimental evidence shows that changing the external potential between two constant values leads to a switching of the metabolism between two corresponding metabolic pathways. These electrodes provide then new options for the control of microbial communities [144].

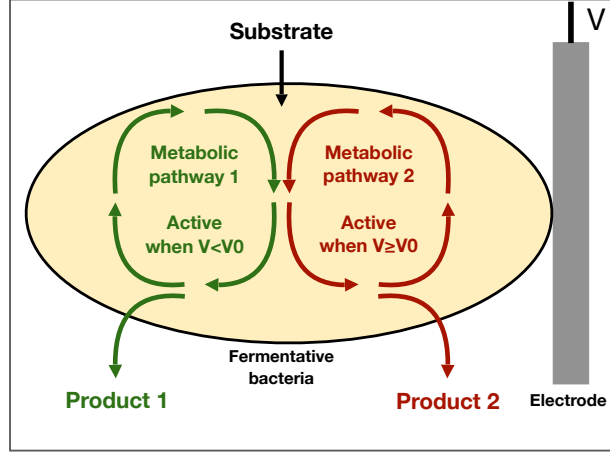

Figure 3.8: Scheme of the switching between the fermentation behaviors of a fermentative bacteria depending on the electrode potential V .

Model description of the electro-fermentation process

In [72] we have proposed a model describing the dynamics of a fermentative microorganism growing on a limiting resource in a batch culture with electrodes. As described above, the application of an external potential through the implementation of an electrode in the bioreactor leads to a switching of the metabolism between two different metabolic pathways. In order to describe this switching phenomenon, we suppose that the fermentative population is split into two sub-populations, x_1 and x_2 , in a commensal relationship to consume a substrate s . The sub-population x_1 with microbial growth rate μ_1 gives rise to a product s_1 and the sub-population x_2 with microbial growth rate μ_2 gives rise to a product s_2 . We suppose that in the absence of polarized electrodes, the fermentation is mainly guided by the population x_1 and when the external voltage is sufficiently large, the metabolic function switches to a metabolism guided by x_2 . This electro-fermentation process can be described by the following system of ordinary differential equations:

$$\begin{aligned} \dot{s} &= -\mu_1(s)x_1 - \mu_2(s)x_2 \\ \dot{x}_1 &= \mu_1(s)x_1 - \alpha r_1 x_1 + (1 - \alpha)r_2 x_2 \\ \dot{x}_2 &= \mu_2(s)x_2 + \alpha r_1 x_1 - (1 - \alpha)r_2 x_2 \end{aligned} \quad (3.12)$$

where $r_1, r_2 > 0$ are positive constants, and $\alpha \in \{0, 1\}$ is a control variable that is directly related to the external potential V and satisfies the following property:

$$\alpha = 0 \text{ if } V < V_0, \quad \text{and} \quad \alpha = 1 \text{ if } V \geq V_0, \quad (3.13)$$

where $V_0 > 0$ is a threshold on the external potential over which the metabolic pathway is guided by x_2 . The value of the threshold potential V_0 depends on the microorganisms x_1 and x_2 . The microbial growth functions are supposed increasing, of type (3.2) for example. Observe that, due to the migration phenomenon between the two sub-populations, the relation between x_1 and x_2 is not simply reduced to a competition phenomenon.

Optimal control problem

The objective is to maximise the total production of the sub-population x_2 over an interval of time $[0, T]$, among functions $\alpha(\cdot)$ that are measurable time functions taking values in $\{0, 1\}$, which amounts to maximise the criterion:

$$J[\alpha(\cdot)] = \int_0^T \mu_2(s(t))x_2(t)dt, \quad (3.14)$$

where $T > 0$ is a fixed finite time horizon.

Remark 69 *From the condition given by (3.13), the control variable α is constrained to take values in the non-convex set $\{0, 1\}$. In this case, one can not a priori guarantee the existence of optimal solutions for the problem (3.12)-(3.14). However, a technical approach consists of first considering the convexified problem, i.e., solve the problem with α taking values in the whole interval $[0, 1]$, for which the existence of solutions is guaranteed (see for instance [189]). Then, the optimal solution can be approached with an arbitrary precision via chattering controls [195], which consist in commuting rapidly between the values 0 and 1 so that the averaged dynamics behave close from that one with α different from 0 and 1.*

We use the Maximum Principle of Pontryagin [179] to obtain necessary optimality conditions given by the following result.

Proposition 70 *Consider the problem (3.12) and (3.14) and let $T > 0$. One distinguish two different cases:*

- 1) *In the case when μ_1 and μ_2 are proportional, an optimal solution of the problem (3.12)-(3.14) has no singular arc. If, in addition, μ_1 and μ_2 are identical, the constant control $\alpha^* \equiv 1$ is optimal on $[0, T]$;*
- 2) *In the case when μ_1 and μ_2 are constants equals to some positive $\bar{\mu}_1$ and $\bar{\mu}_2$, respectively, one has the following two cases:*
 - *If $\bar{\mu}_1 \leq \bar{\mu}_2$, then $\alpha^* = 1$ is optimal on $[0, T]$;*
 - *If $\bar{\mu}_1 > \bar{\mu}_2$, then the control:*

$$\alpha^*(t) = \begin{cases} 1 & \text{if } t \geq \min \left(0, T - \frac{\log(\inf \{p > 0; \phi(p) < 0\} + 1)}{\bar{\mu}_2} \right) \\ 0 & \text{otherwise} \end{cases}$$

is optimal on $[0, T]$, where $\phi(\cdot)$ is given by

$$\phi(p) = \begin{cases} \frac{K + L - K(L - 1)p - (L + K)(p + 1)^{-K}}{K(K + 1)} & K \notin \{-1, 0\} \\ (1 - L)p + L \log(p + 1) & K = 0 \\ -L + L(p + 1) + \log(p + 1)(1 - L) & K = -1, \end{cases} \quad (3.15)$$

with $L = \frac{\bar{\mu}_1}{\bar{\mu}_2}$ and $K = \frac{r_1 - \bar{\mu}_1}{\bar{\mu}_2}$.

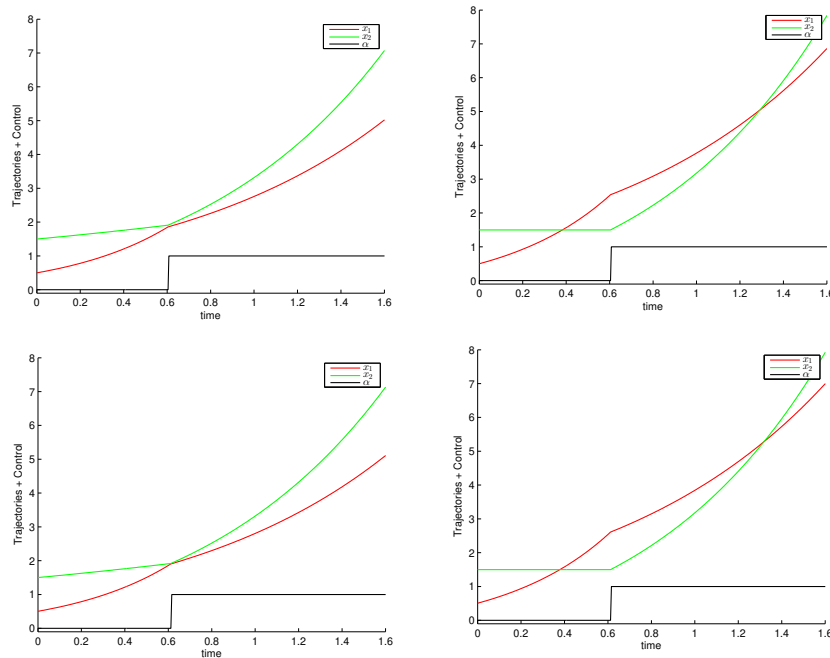

Figure 3.9: Exact optimal control (**top**) and optimal control computed with Bocop (**bottom**) for $r_2 = 0.1$ (**left**) and $r_2 = 0.5$ (**right**).

Table 3.1: Numerical values of the different parameters: case of constant growth rates.

$\bar{\mu}_1$	$\bar{\mu}_2$	r_1	r_2	T
2	1/2	1	0.1–0.5	2

Thanks to Proposition 70, the optimal control of problem (3.12)-(3.14) is a sequence of commutation between $\alpha = 0$ and $\alpha = 1$. According to Remark 69, we can guarantee in absence of the singular arc that the optimal solution is reached with α taking only values 0 and 1 (even though the number of switches might be large or infinite). The case 1) in Proposition 70 might be considered quite unrealistic. However, it could occur that growth rates are quite close to each other when the concentration s is not too large, which could then justify the consideration of this case. Similarly, the case 2) can be justified by the fact that when the population growths follows the classical Monod function (3.2) and that the concentration $s(0)$ is quite large, having $\mu_i(s) = \bar{\mu}_i$ can be a good approximation on the finite time horizon $[0, T]$ (provided T not to be too large). The obtained results show that the optimal control strategy is far from being trivial, in the sense that undesirable metabolic pathways may be visited by the fermentative bacteria for the maximisation of a desired fermentation product.

Numerical example and discussion

Let us consider system (3.12) where the growth rate functions are constants with values given in Table 3.1.

In this case, the optimal control is given by:

$$\alpha^*(t) = \begin{cases} 1 & \text{if } t \geq \min(0, 2 - \log(4)) \\ 0 & \text{otherwise.} \end{cases}$$

On Figure 3.9, we plot (with Matlab) the optimal control given by Proposition 70 together with the optimal trajectories in the two cases $r_2 = 0.1$ (top-left) and $r_2 = 0.5$ (top-right). As a verification, these plots are also compared with the ones obtained with Bocop [14], which is a numerical optimisation software dedicated to optimal control problems (using direct method) on Figure 3.9 (bottom).

3.4 Analysis and control of time-delay systems for neurosciences applications

Basal ganglia are deep brain structures involved in voluntary motor control as well as in cognitive and motivational processes [89]. They have been extensively studied in connection with a variety of pathological observations such as the Parkinson's disease [101]. The Parkinson's disease is highly correlated to a pathological synchronisation (oscillations in the beta-band) between two principal nuclei in the basal ganglia, namely the subthalamic nucleus (STN) and the external globus pallidus (GPe). The deep brain stimulation (DBS) is an efficient technique which consists in the implantation of a lead that delivers electrical impulses in the STN [11]. The amplitude and frequency of stimulations are adjusted by the surgeon after the operation, and these parameters remain fixed, with only sporadic adjustments during medical visits. Even though the positive therapeutic effects of the DBS, there is no consensus that describe properly the mechanism of this treatment. In addition, the treatment is not always optimal and there is still room for improvements [114].

One of the directions proposed recently in order to optimise the efficiency of DBS is closed-loop stimulation [176], using real-time measurements of brain activity (see Figure 3.11). In order to achieve this closed-loop stimulation, the need of computational models is of first order. A certain number of mesoscopic firing rate models have been proposed in the literature (see, e.g., [147, 155]). Starting from the well known firing-rate model proposed in [147], in [81] we design a closed-loop stimulation strategy. This will be presented in Section 3.4.3. In the next section, we present the basic firing rate model from [147]. Based on this latter model, in Section 3.4.2 we propose and analyse a model describing the effects of external excitatory nuclei on basal ganglia oscillations.

3.4.1 Firing rate model for basal ganglia oscillations

A firing rate model of the STN-GPe loop has been proposed in [147]. This is described by the following dynamics

$$\begin{aligned} \tau_s \dot{x}_s(t) &= -x_s(t) + S_s (-\omega_{gs}x_g(t - \tau_{gs}) + \omega_{cs}\nu_s) \\ \tau_g \dot{x}_g(t) &= -x_g(t) + S_g (\omega_{sg}x_s(t - \tau_{sg}) - \omega_{gg}x_g(t - \tau_{gg}) + \omega_{xg}\nu_g) - x_g(t), \end{aligned} \tag{3.16}$$

where x_s and x_g represent the firing rates of the STN and GPe, respectively. The positive gains ω_{gs} , ω_{sg} and ω_{gg} represent the weights of the different interconnections between these

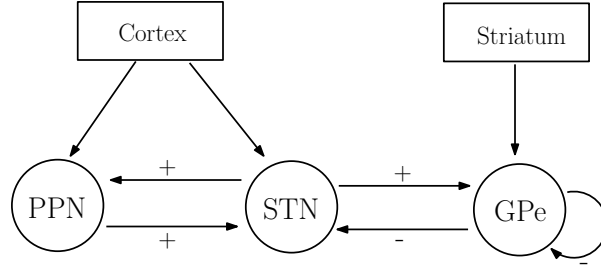

Figure 3.10: Schematic diagram of three nuclei: STN, GPe and PPN.

neuronal populations. The variables ν_s and ν_g together with the associated weights ω_{cs} and ω_{xg} describe the external inputs, from the striatum and cortex, received by these populations. The time constants τ_s and τ_g describe how rapidly the two populations react to those inputs. We assume that the positive delays τ_{gs} , τ_{sg} and τ_{gg} are constant. The presence of such delays is due both to the time needed by action potentials to travel along the axon and to the chemical kinetics involved in synaptic transmissions. The scalar functions S_s and S_g define the activation functions of STN and GPe, respectively. These activation functions may be given by the following sigmoidal functions

$$S_i(x) = \frac{B_i M_i}{B_i + (M_i - B_i)e^{-4x/M_i}}, \quad \forall i \in \{s, g\}, \quad (3.17)$$

where B_i and M_i , for $i \in \{s, g\}$, are positive constants. The values of the STN-GPe interconnection gains are given by:

$$\omega_{ij}^i = \omega_{ij}^H + k(\omega_{ij}^D - \omega_{ij}^H), \quad \forall i, j \in \{s, g\}, \quad (3.18)$$

where $k \in [0, 1]$ is a parameter that describes the evolution of Parkinson's disease, and ω_{ij}^H and ω_{ij}^D are, respectively, the interconnection gains for the healthy and diseased states (given in [81, Table 1]). In the healthy case, we have $k = 0$. In the fully pathological case, we have $k = 1$. Intermediate values of the parameter are used to describe the disease's evolution.

3.4.2 The role of external excitatory nuclei on basal ganglia oscillations

Basal ganglia are highly interconnected with the pedunculopontine nucleus (PPN) [135]. The PPN might thus have an influence on the oscillatory activity of the STN-GPe pacemaker. In human patients, monkeys, and rats, the PPN was shown to exert an excitatory action on the STN, which projects back excitatory axons to the PPN [59]. Additionally, the STN and PPN nuclei receive inputs from cortex [135]. Based on the firing rate model (3.16) and in view of the excitatory interactions described previously, in [83] we developed a mathematical model that describes the interaction between the three neuronal populations: PPN, STN and GPe (see Figure 3.10). This is given by the following system

$$\begin{aligned}
\tau_p \dot{x}_p(t) &= S_p(\omega_{sp}x_s(t - \tau_{sp}) + \omega_{cp}\nu_p) - x_p(t), \\
\tau_s \dot{x}_s(t) &= -x_s(t) + S_s(\omega_{ps}x_s(t - \tau_{ps}) - \omega_{gs}x_g(t - \tau_{gs}) + \omega_{cs}\nu_s) \\
\tau_g \dot{x}_g(t) &= -x_g(t) + S_g(\omega_{sg}x_s(t - \tau_{sg}) - \omega_{gg}x_g(t - \tau_{gg}) + \omega_{xg}\nu_g) - x_g(t),
\end{aligned} \tag{3.19}$$

where x_p represents the firing rate of the PPN. The positive gains ω_{ps} and ω_{sp} represent the weights of the interconnection between PPN and STN. The variable ν_p describes the cortical input received by the PPN. The time constant τ_p describes how rapidly the PPN reacts to this input. The parameters τ_{sp} and τ_{ps} describe the delay of interconnection between PPN and STN. The function S_p is the activation function of PPN and can be similarly given by (3.17), and the the evolution of Parkinson's disease by considering the PPN respect the same rule as in (3.18).

Proposition 71 *Consider the system (3.19). The following statements are true:*

- For any constant vector $\nu = (\nu_s, \nu_g, \nu_p)^T \in \mathbb{R}^3$ all equilibrium points of the system (3.19) belong to the unit cube.
- If the following condition is satisfied

$$\sigma_p \sigma_s \omega_{ps} \omega_{sp} \leq 1, \tag{3.20}$$

where σ_p and σ_s are the upper-bounds of S'_p and S'_s , respectively, then the system (3.19) has a unique equilibrium point for any $\nu \in \mathbb{R}^3$. Otherwise, there exists a vector $\nu \in \mathbb{R}^3$ such that the system (3.19) has at least three distinct equilibria.

- If condition (3.20) is not satisfied and moreover

$$\left(\sigma_p \omega_{ps} \omega_{sp} - \frac{1}{\sigma_s} \right) \left(\omega_{gg} + \frac{1}{\sigma_g} \right) > \omega_{gs} \omega_{sg} \tag{3.21}$$

then, for each input $\nu_g \in \mathbb{R}$, there exists a pair of inputs $(\nu_s, \nu_p) \in \mathbb{R}^2$ such that the system (3.19) has at least three distinct equilibria.

Proposition 71 shows the role of PPN in the existence of a unique equilibrium for (3.19). In particular, if condition (3.20) is satisfied, meaning that if the weights of the interconnection between STN and PPN are sufficiently smalls, then system (3.19) has a unique equilibrium point for every constant input. Notice that, in the absence of PPN, condition (3.20) is always satisfied implying the uniqueness of an equilibrium point. When condition (3.20) is not satisfied, the existence of multiple equilibria can occur for an arbitrary constant striatal input.

For each $\nu^* \in \mathbb{R}^3$ let x^* be the associated equilibrium point and let us define the following quantities

$$\sigma_s^* = S'_s(\omega_{ps}x_s^* - \omega_{gs}x_g^* + \omega_{cs}\nu_s^*), \quad \sigma_g^* = S'_g(\omega_{sg}x_s^* - \omega_{gg}x_g^* + \omega_{xg}\nu_g^*), \quad \sigma_p^* = S'_p(\omega_{sp}x_s^* + \omega_{cp}\nu_p^*),$$

as well as the following transfer functions

$$\begin{aligned}
H_s(s) &= \frac{\sigma_s^*}{\tau_s s + 1}, \quad H_p(s) = \frac{\sigma_p^*}{\tau_p s + 1}, \quad H_g(s) = \frac{\sigma_g^*}{\tau_g s + 1 + \sigma_g^* \omega_{gg} e^{-\tau_{gg}s}}, \\
H_{sp} &= \frac{H_s}{1 - \omega_{ps} \omega_{sp} H_s H_p(s) e^{-(\tau_{ps} + \tau_{sp})s}} \quad \text{and} \quad H_{sg} = \frac{H_s}{1 + \omega_{gs} \omega_{sg} H_s H_g(s) e^{-(\tau_{sg} + \tau_{gs})s}},
\end{aligned} \tag{3.22}$$

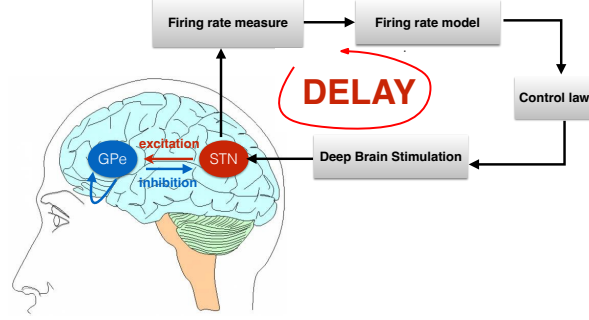

Figure 3.11: Closed-loop deep brain stimulation.

relative to the linearised dynamics associated to (3.19) around x^* .

Proposition 72 *Consider system (3.19). Let $\nu^* \in \mathbb{R}^3$ be any constant input and let x^* be the associated equilibrium point. Suppose that the transfer functions H_g, H_{sp} and H_{sg} are stable. For each $\tau_{ps}, \tau_{sp} > 0$ there exist $\omega > 0$ and $\tau = \tau(\omega) > 0$ such that if $\omega_{ps}\omega_{sp} < \omega$ and $\tau_{gg} + \tau_{sg} + \tau_{gs} < \tau$ then system (3.19) is locally asymptotically stable around x^* .*

Proposition 72 gives an idea on how an external nucleus such as the PPN can alter the stability of the STN–GPe network. This influence appears through the delay margin τ that depends obviously on the interconnection gains and the transmission delays of the STN–PPN network.

3.4.3 Closed-loop deep brain stimulation

Here we don't consider the influence of PPN on the STN–GPe loop. In the absence of stimulation, in the healthy case, the only equilibrium point of the model is locally asymptotically stable. As a consequence, no STN–GPe endogenous oscillations take place. This is not the case for the pathological case, where the stronger synaptic weights between STN and GPe result in an increase in the pallido-subthalamic loop gain that compromises stability. This generates a limit cycle (for details, see, for example, [147]), whose frequency stands in the beta-band, thus correlating with experimental observations [90]. It is therefore natural to explore the idea of using the exogenous stimulation signal u in order to restore the system's stability in the pathological situation. Then, based on (3.16) we propose the following dynamics

$$\begin{aligned} \tau_s \dot{x}_s(t) &= -x_s(t) + S_s (-\omega_{gs}x_g(t - \tau_{gs}) + \omega_{cs}\nu_s + u(t - \tau)) \\ \tau_g \dot{x}_g(t) &= -x_g(t) + S_g (\omega_{sg}x_s(t - \tau_{sg}) - \omega_{gg}x_g(t - \tau_{gg}) + \omega_{xg}\nu_g) - x_g(t), \end{aligned} \quad (3.23)$$

where the delay τ in the external stimulation signal u is considered in order to take into account the delays present in both measurement and stimulation devices.

In order to reduce the STN–GPe loop gain while taking into account the destabilising effect of the delay in the input we consider the following proportional filtered control:

$$\dot{u}(t) = \theta (-u(t) - k(x_s - \bar{x}_s)), \quad (3.24)$$

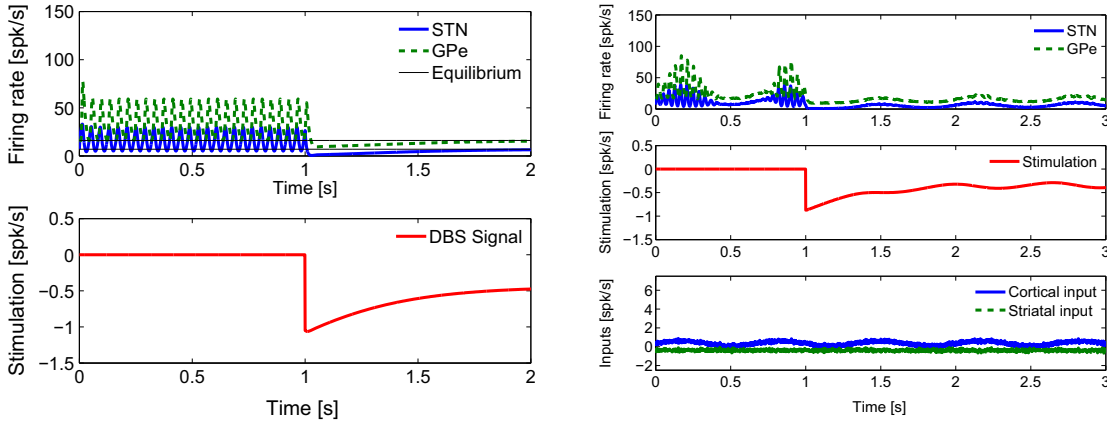

Figure 3.12: Left: simulation showing the impact on pathological oscillations of the control (3.24) with $k = 45$. The reference firing rate is $\bar{x}_s = 4 \text{ Hz}$ and a filter frequency $\theta = 0.15 \text{ Hz}$ is considered. The delay in the feedback loop $\tau = 100 \text{ ms}$. The pathological oscillations are effectively reduced despite severe acquisition and actuation delays. Right: effect of an intermittent cortical input (1.5 Hz frequency) on oscillations, with and without closed-loop stimulation. In the absence of stimulation the cortical input generates a wave of oscillations in the beta-band each time it has an elevated value. The closed-loop stimulation clearly counters this instability.

where θ is the filter's bandwidth, k is a proportional gain that prescribes the intensity of stimulation, and \bar{x}_s is a reference value. In [81], we show that an adequate choice of these parameters can increase arbitrarily the robustness of the stimulation scheme with respect to the feedback loop delay. The effect of this stimulation on pathological oscillations is shown in Figure 3.12. This stability result is formulated by the following result.

Proposition 73 *For each constant delay $\tau > 0$, each firing rate reference \bar{x}_s , and each gain $k > 0$, there exists a frequency $\theta^* > 0$ such that for every filter frequency $0 < \theta < \theta^*$, the closed-loop system (3.23)-(3.24) is locally asymptotically stable.*

Based on the elementary feedback control (3.24), different feedback strategies through more elaborated models have been developed in the literature (see, e.g., [35]).

3.5 Urban pigeon population management: viability theory approach

Urban pigeon population can reach high densities in cities and cause cohabitation problems with urban citizens. In response to social complaints, different regulation programs are implemented by local authorities to reduce this nuisance and help the coexistence between city dwellers and urban pigeons. These programs include different measures, from culling juvenile or adult pigeons, to more welfare-based approaches like limiting resources and/or eggs removal from public pigeon houses (see e.g. [58]). While some people see pigeons as flying rats, others think that pigeons are symbolic and human-pigeon coexistence is not solely a question of pigeon

numbers. In addition, any regulation strategy must be based on a minimum knowledge about the pigeon ecology and the eventual ecological consequences. In fact, experimental evidences show long-term side effects of some regulation methods. For example, egg removal may lead to an increase in laying frequency and in the total number of laid eggs in a year, together with an associated decrease in adult pigeon's body condition [99].

3.5.1 Mathematical model

In [65], we propose a model that describe the dynamics of an urban pigeon population which is subject to two different regulation strategies: eggs removal and ressources limitation. An age-structured model of juvenile and adult pigeons which are split in two different sites is considered. Because urban citizens satisfaction may differ from one site to another, we suppose that in each site the pigeon population is subject to different eggs removal and ressources limitation strategies with different degrees of severity. According to the pigeon ecology (see [65] for more details), we consider that pigeons disperse between the two sites, depending on both eggs removal and ressources limitation strategies adopted in each site. This is resumed by the following equations

$$\begin{aligned}\dot{x}_{ji} &= n_i(x_{ai}, u_i)x_{ai} - m_{ji}(x_{ji}, u_i)x_{ji} - p_i(x_{ji}, u_i)x_{ji} - \sum_{k=1}^2 (-1)^{i+k} x_{jk} \phi_{jk}(x_{jk}, u_k) \\ \dot{x}_{ai} &= -m_{ai}(x_{ai}, u_i)x_{ai} + p_i(x_{ji}, u_i)x_{ji} - \sum_{k=1}^2 (-1)^{i+k} x_{ak} \phi_{ak}(x_{ak}, u_k)\end{aligned}\tag{3.25}$$

where x_{ji} and x_{ai} denote the size of juvenile and adult pigeons which are subject to the control $u_i = (r_i, s_i)$ where r_i denotes the eggs removal strategy and s_i denotes the ressources limitation strategy, for $i = 1, 2$. The function $n_i(\cdot)$ describes the reproduction of adult pigeons; $m_{ai}(\cdot)$ and $m_{ji}(\cdot)$ describe the mortality of adult and juvenile pigeons, respectively, for $i = 1, 2$. The function $p_i(\cdot)$ represents the transfer rate from juvenile to adult, for $i = 1, 2$. The functions ϕ_{jk} and ϕ_{ak} represent the dispersal rates of juvenile and adult pigeons from population i to $k \neq i$, for $i, k \in \{1, 2\}$.

A detailed description on the impacts of the different management strategies on the pigeon ecology as well as of the different parameters and functions appearing in (3.25) are given in [65].

3.5.2 Management of the pigeon population as a viability problem

As mentioned before, to achieve citizens satisfaction, the local authorities fix an upper limit on the total size of the pigeon population. Once this population exceeds this upper limit, the local authorities try to reduce this increased pigeon population by using different management methods. Since this satisfaction may be different between sites, this upper limit may be different from one site to another. On the other hand, urban citizens are also supposed to be dissatisfied by the total absence of urban pigeons or if they perceive pigeons in bad conditions; a too low number of pigeons can be perceived as reflecting bad survival conditions for the pigeon population. Thus, as a first approach, the urban citizens satisfaction can be modeled by a state constraint set with upper and lower bounds on the number of pigeons. This is given by the following:

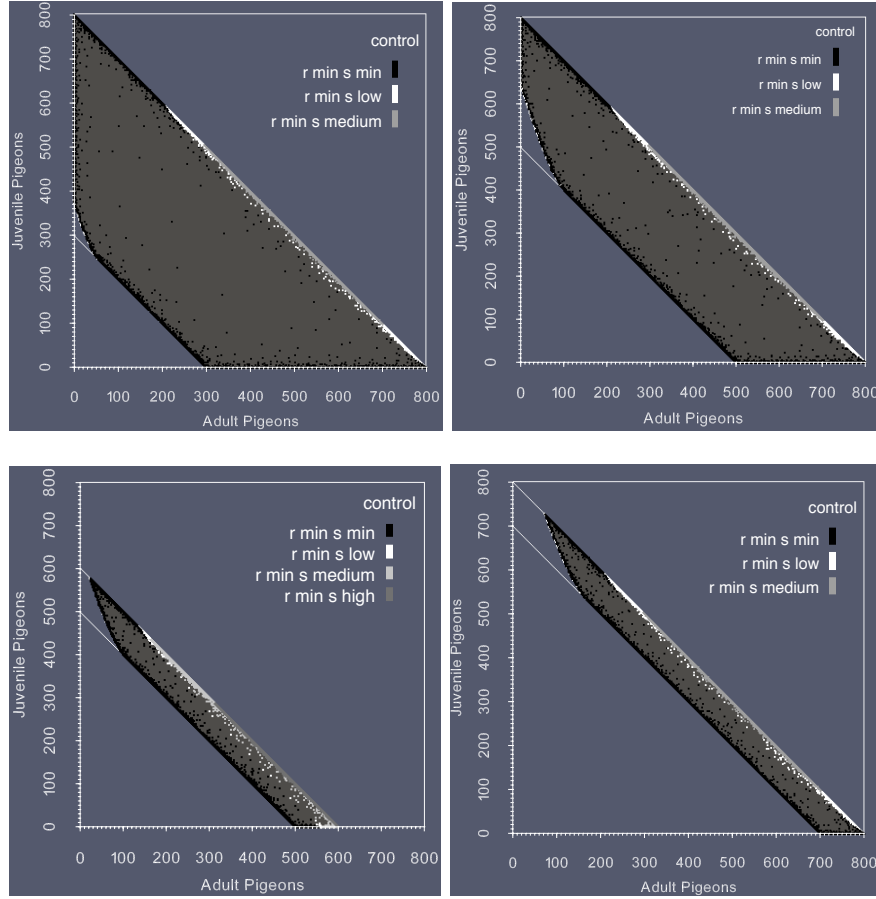

Figure 3.13: This figure shows the viability kernel (in dark grey) of the viability problem (2.43)-(2.44) in four different cases: top-left with $(\underline{M}, \overline{M}) = (300, 800)$, top-right with $(\underline{M}, \overline{M}) = (500, 800)$, bottom-left with $(\underline{M}, \overline{M}) = (500, 700)$ and bottom-right with $(\underline{M}, \overline{M}) = (700, 800)$.

$$(K) \begin{cases} \underline{M}_i \leq x_{ji}(t) + x_{ai}(t) \leq \overline{M}_i, & \forall t \geq 0, \\ x_{ai}(t) \geq 0, & \forall t \geq 0, \\ x_{ji}(t) \geq 0, & \forall t \geq 0, \end{cases} \quad (3.26)$$

where $\underline{M}_i, \overline{M}_i$ determine the lower and upper limits, respectively, for $i \in \{1, 2\}$.

The pigeon population management is then represented by the viability problem (3.25)-(3.26). Using the viability algorithm developed in [39], approximate viability kernel are computed in [65].

3.5.3 Numerical computation of viability kernels

Different viability kernels corresponding to the problem (3.25)-(3.26) have been numerically computed in [65]. Here we show a viability kernel computed in the case of one pigeon population

by considering one control action, the resources limitation, and by neglecting the dispersal effects. Four different cases, corresponding to different values of \underline{M} and \overline{M} , are considered. These viability kernels are represented by Figure 3.13. Points where the viable control is computed appear in the viability kernel. The colour gradient indicates the control values needed for r and s in order to force the trajectories to stay inside K . These control values are spread over different levels: “min”, “low”, “medium” and “high”. The “min” value indicates the null control values. The “low” value indicates the non-null control values which are less than 0.3. The “medium” value indicates the control values between 0.4 and 0.6 and the “high” value indicates the control values between 0.7 and 0.9. Observe that regions where the points are not black, the minimum control leads the trajectories outside the state of constraint set. Thus, an active control is needed in these regions. Regions where the adult pigeons size is too large, a strong limiting resources strategy is needed in order to maintain the population inside the constraint set. There is no viable control in regions where the adult pigeons size is too low; thus starting from these regions, the pigeon population tends to the extinction.

The viability kernels computed in [65] corresponds to a very simple model of pigeons dynamics with few demographic parameters. However, these viability kernels shows the advantage of an adaptive control: the largest effort in terms of control is only mandatory near the boundary of the constraint set, contrary to constant control policies.

Chapter 4

Perspectives

We list here research perspectives emerging from the topics discussed in this document.

4.1 Relaxed converse Lyapunov theorems for switching retarded systems

The results presented in Section 1.6 show a significant difference between the Lyapunov-Krasovskii characterisations of the UGAS and the UGES properties of systems described by retarded functional differential equations. Theorem 41 shows that the UGAS property is equivalent to the existence of a Lyapunov-Krasovskii functional that dissipates in a point-wise manner along the system's solutions; by point-wise dissipation we mean a dissipation rate which depends on the norm of the current solution and not on its history. However, by Theorem 42, the sufficient condition for the UGES property is given through a history norm-dependent dissipation rate. From a computational point of view, it is easier to derive a point-wise dissipation rate when differentiating the Lyapunov-Krasovskii functional along the system's solutions. But, it is not known whether UGES can be established through a point-wise dissipation.

Seeing the importance of relaxing the sufficiency part of Theorem 42, significant research activity has been devoted around this question, in the case of time-delay systems (with constant delay and without switch). For example, in [24] the authors show that a relaxed sufficient condition, in which the dissipation rate of the Lyapunov-Krasovskii functional involves only the point-wise value of the solution, implies the global exponential stability for time-delay systems defined through globally Lipschitz vector fields. Knowing that globally Lipschitz is a so conservative property, in [23] the authors enlarge the class of systems for which global exponential stability can be established under a point-wise dissipation. This is given by replacing the globally Lipschitz property by more relaxed *growth conditions* on the vector field describing the dynamics.

For switching retarded systems, we guess that under the same growth conditions as in [23] that hold uniformly with respect to the switching signal, the UGES property can be established when a Lyapunov-Krasovskii functional satisfies a dissipation inequality in which the dissipation rate involves solely the current value of the state. In the case of merely Lipschitz on bounded sets vector fields, even in the case of autonomous nonlinear delay systems the question is still

open. Ideally, in future works we would like to confirm or infirm the following conjecture.

Conjecture 74 *If there exist a functional $V : \mathcal{C}([-\Delta, 0], \mathbb{R}^n) \rightarrow \mathbb{R}_+$, Lipschitz on bounded subsets of $\mathcal{C}([-\Delta, 0], \mathbb{R}^n)$, and positive reals α_1, α_2 and α_3 , such that the following inequalities hold*

$$(i) \quad \alpha_1 |\varphi(0)|^2 \leq V(\varphi) \leq \alpha_2 \|\varphi\|_\infty^2, \quad \forall \varphi \in \mathcal{C}([-\Delta, 0], \mathbb{R}^n),$$

$$(ii) \quad D^+V(\varphi) \leq -\alpha_3 |\varphi(0)|^2, \quad \forall \varphi \in \mathcal{C}([-\Delta, 0], \mathbb{R}^n),$$

then system $(\mathcal{C}([-\Delta, 0], \mathbb{R}^n), \mathcal{S}^M, \phi_0^\Delta)$ is UGES.

A related question concerns the ISS property of switching retarded systems. Observe that, by Theorem 39 the dissipation rate of the Lyapunov-Krasovskii functional involves the norm of the state. Similarly to the above discussion, the question is does a point-wise dissipation rate is enough to guarantee ISS. Thanks to Theorem 44, where a link between the UGES of the input-free system and the ISS properties is established, a first positive answer may be given for the point-wise dissipation rate question. Indeed, as for dynamics described by globally Lipschitz vector fields ISS is a consequence of the UGES property of the input-free system and as in [24] a point-wise dissipation rate is guaranteed for this class of systems, we expect that point-wise dissipation is enough to guarantee ISS for globally Lipschitz switching retarded systems. In [23], equally to the case of global exponential stability property, the authors enlarge the class of systems for which ISS can be established under a point-wise dissipation by replacing the globally Lipschitz property by more relaxed growth conditions on the vector field describing the dynamics. For switching retarded systems, we guess that this extension also holds. Ideally, we would like to confirm or infirm the following conjecture.

Conjecture 75 *If there exist a Lipschitz on bounded sets functional $V : \mathcal{C}([-\Delta, 0], \mathbb{R}^n) \rightarrow \mathbb{R}_+$, positive reals $\alpha_1, \alpha_2, \alpha_3$, and a function $\alpha_4 \in \mathcal{K}$ such that the following inequalities hold*

$$(i) \quad \alpha_1 |\varphi(0)|^2 \leq V(\varphi) \leq \alpha_2 \|\varphi\|_\infty^2, \quad \forall \varphi \in \mathcal{C}([-\Delta, 0], \mathbb{R}^n),$$

$$(ii) \quad D^+V(\varphi, u) \leq -\alpha_3 |\varphi(0)|^2 + \alpha_4(|u|), \quad \forall \varphi \in \mathcal{C}([-\Delta, 0], \mathbb{R}^n), \forall u \in \mathbb{R}^m,$$

then system $(\mathcal{C}([-\Delta, 0], \mathbb{R}^n), \mathcal{S}^M, \phi_u^\Delta)$ is M-ISS.

Knowing that these “point-wise dissipation” properties often simplifies the analysis of systems described by retarded differential equations, we will be interested to solve the above two conjectures. This can be done in collaboration with Antoine CHAILLET and Pierdomenico PEPE.

4.2 Singularly perturbed switching linear systems

A two-time-scales system is a system for which some variables evolve on a much faster rate than the others. This class of systems appears in several industrial and engineering applications (see, e.g., [109, 127]) where simplified models can be formulated by decoupling the fast from the slow dynamics. From control point of view, this allows to design a controller based on a reduced order model. However, the design based on a simplified model may not guarantee the

stability of the overall system. To avoid this problem, a well-established framework developed in the mathematical and control community is that of singular perturbations [111]. The singular perturbation theory allows the separation between slow and fast variables where different controllers for different time-scale variables can be designed in order to lead the overall system to its desired performance. This approach has been widely used in the literature of control theory (see, e.g., [1, 54]).

Few stability criteria for singularly perturbed switching systems have been obtained in the literature: among them, let us mention [126] where conditions are obtained based on the existence of a common quadratic Lyapunov function, [38] characterising the stability in dimension two based on the corresponding criteria in the non-singularly-perturbed case [10, 16], and [4] where stability for time-delay singularly perturbed switching systems is based on dwell-time criteria.

Formally, let us consider $\Sigma = (\Sigma_\varepsilon)_\varepsilon$ the family of switching linear systems

$$\Sigma_\varepsilon : \quad \begin{aligned} \dot{x}(t) &= A(t)x(t) + B(t)y(t), \\ \varepsilon \dot{y}(t) &= C(t)x(t) + D(t)y(t), \end{aligned}$$

where ε denotes a small positive parameter and A, B, C, D are matrix-valued signals undergoing arbitrary switching within a prescribed bounded range. The variables x and y represent here the slow and fast variables, respectively. One of the main issues for such families of systems consists in understanding the time-asymptotic behavior of Σ_ε as $t \rightarrow +\infty$ in the regime where ε is sufficiently small.

Two limit systems have been identified in the literature to give necessary and sufficient conditions for the exponential stability of Σ . The first one is given by the switched system

$$\bar{\Sigma} : \quad \dot{x}(t) = (A(t) - B(t)D(t)^{-1}C(t))x(t), \quad (4.1)$$

with $y(t) = -D(t)^{-1}C(t)x(t)$ (with an assumption on the uniform invertibility of $D(t)$), and the second one is given by the differential inclusion

$$\hat{\Sigma} : \quad \dot{x}(t) \in A(t)x(t) + B(t)K(x(t)), \quad (4.2)$$

where, for each fixed \bar{x} , $K(\bar{x})$ is the set of attraction of the dynamics $\dot{y} = C(t)\bar{x} + D(t)y$. System (4.1) and system (4.2) give necessary and sufficient conditions for the exponential stability of Σ , in the following sense: the exponential instability of (4.1) is sufficient for the exponential instability of Σ , however the exponential stability of (4.2) is sufficient for that stability of Σ . In addition, it has already been observed that the switching system (4.1) may be exponentially stable even when, for every $\varepsilon > 0$, Σ_ε is unstable (see, e.g., [126]). As well as, in [38], it has been observed that the switching system (4.2) may be not exponentially stable even when, for every $\varepsilon > 0$, Σ_ε is exponentially stable. By consequence, the two limit systems (4.1) and (4.2) does not provide an optimal approximation of the slow dynamics of Σ . In [25], we propose a new limit system $\check{\Sigma}$ which contains (4.1) and provides sufficient condition for the exponential instability of Σ . Moreover, we show that the maximal Lyapunov exponents of (4.1) is lower bounded by that of $\check{\Sigma}$. More precisely, we show the following property

$$\lambda(\bar{\Sigma}) \leq \lambda(\check{\Sigma}) \leq \liminf_{\varepsilon \rightarrow 0^+} \lambda(\Sigma_\varepsilon) \leq \limsup_{\varepsilon \rightarrow 0^+} \lambda(\Sigma_\varepsilon) \leq \lambda(\hat{\Sigma}), \quad (4.3)$$

where $\lambda(\bar{\Sigma})$, $\lambda(\check{\Sigma})$, $\lambda(\hat{\Sigma})$ and $\lambda(\Sigma_\varepsilon)$ denote the maximal Lyapunov exponent of $\bar{\Sigma}$, $\check{\Sigma}$, $\hat{\Sigma}$ and Σ_ε , respectively. Recall that the maximal Lyapunov exponent of a switching linear system is the largest asymptotic exponential rate as the time goes to $+\infty$ among all trajectories of the system. The idea behind introducing the new limit system $\check{\Sigma}$ is the following: when signals switch at a rate slower than $1/\varepsilon$ system $\bar{\Sigma}$ closely approximates the slow dynamics of Σ_ε . However, when signals switch at a rate faster than $1/\varepsilon$ system $\hat{\Sigma}$ closely approximates the slow dynamics of Σ_ε . The new limit system $\check{\Sigma}$ corresponds to signals switching at a rate exactly equal to $1/\varepsilon$.

Many interesting questions concerning the characterisation of the stability of Σ_ε as ε goes to zero are still open. The first question is, does the liminf of the maximal Lyapunov exponents of Σ_ε as ε goes to zero is equal to the maximal Lyapunov exponents of $\check{\Sigma}$. We believe that this question has a positive answer. This is formulated by the following conjecture.

Conjecture 76 *If the fast dynamics are exponentially stable, then the liminf of the maximal Lyapunov exponents of Σ_ε as ε goes to zero is equal to the maximal Lyapunov exponents of $\check{\Sigma}$.*

Another important question concerns the extension of the new limit system proposed in [25] to infinite dimensional systems. The principal motivation of this last point concerns the stability of singularly perturbed linear delay systems for which few results exist in the literature. In fact, as it is already underlined in Section 1.4.5, a retarded differential system with uncertain delay can be equivalently interpreted as a switched system in infinite-dimensional Banach space. Thus, after representing a singularly perturbed delay system as a delay-free singularly perturbed switched system evolving in a Banach space, stability results could emerge for the starting retarded singularly perturbed finite-dimensional system.

This research activity can be done in collaboration with Yacine CHITOUR, Paolo MASON and Mario SIGALOTTI.

4.3 Control and observation of switching systems: applications in electro-fermentation

In section 3.3.3 we briefly introduced and discussed the electro-fermentation process which consists in electrochemically controlling the microbial metabolism through the implementation of electrodes in the bioreactor [144]. The main goal in this context is the understanding and supervision of the dynamical interplay between the biological and the power electrical part. This requires the interaction between different fields including mathematical modelling, control theory, microbial ecology, and power electronics. This will be done in three main steps:

Dynamic modelling of more complex electro-fermentation processes

The first step is the validation of the mathematical model proposed in [72] and given by (3.12) in the case of pure batch culture. The validation of this model requires several back and forth confrontations with experimental data. Then, we shall consider an extension of this model to allow the commensalism between bacterial species in mixed culture. Indeed, it is notably possible to design a fermentation process involving fermentative species and a bioanode colonised with electroactive species able to consume undesired fermentation by-products as electron donors.

Electroactive microorganisms would release electrons on the electrode that could be used for electricity or hydrogen production and simultaneously lead to an electro-fermentation phenomenon. This modelling as well as the experimental validation of the developed models will be essentially held in collaboration with Jérôme HARMAND and Elie DESMOND-LE QUÉMÉNER as experts on modeling of microbial electrochemical systems.

Theoretical analysis of the developed models

Taking into consideration that unadapted electrode potential may lead to the extinction of the fermentative microorganism, one has to deal with some constraints on the electrode potential and the concentration of the fermentative microorganism in order to guarantee the sustainability of the microbial ecosystem. The mathematical analysis of the global behavior of the developed models will be carried out. For example, a well known phenomenon in bioprocesses is the bistability when inhibition occurs as described in Section 3.3.1. We expect to have similar phenomena here. Concerning the necessity of setting up models with constraints, the formulation in terms of viability problem is expected. The existence of viability algorithms and efficient numerical methods, permitting the computation/approximation of the largest subset of viable initial conditions, will be advantageous. Optimal trajectories, relative to an optimisation criterion, within the viability kernel will be then studied.

Control and observation of the microbial metabolism

Knowing that the activity of electroactive microorganisms is directly related to the production of electricity, the estimation of the biofilm activity over an anode is mandatory in order to control the microbial activity. Based on the developed models we shall reformulate this question as an observation problem for the reconstruction of an output of the system, here the growth rate of the electroactive microorganisms, using the available measurements that are gas production and/or the difference of potential between the electrodes. Another challenging problem concerns the stabilisation of the system around a desirable equilibrium point. Indeed, as already underlined, bistability phenomena may appear leading to the dysfunction of the bioprocess. Thus, control law will be developed for a real-time piloting of the system. The control can be through the electrical part vaguely represented by the term α in system (3.12). Moreover, due to inherent uncertainties and possible biological adaptation with time, we shall formulate an extremum seeking problem for the control to track on-line the best operating point. This can be done by adapting the MPPT principle [115] from photovoltaic solar energy context to electro-bioprocesses. This part can be done in collaboration with Florentina NICOLAU, Jean-Pierre BARBOT and Alain RAPAPORT.

Bibliography

- [1] Mahmoud Abdelrahim, Romain Postoyan, and Jamal Daafouz. Event-triggered control of nonlinear singularly perturbed systems based only on the slow dynamics. *Automatica*, 52:15–22, 2015.
- [2] Jürgen Ackermann. *Sampled-Data Control Systems: Analysis and Synthesis, Robust System Design*, volume 1. Springer-Verlag, Berlin-New York, 1983.
- [3] Andrei A. Agrachev and Daniel Liberzon. Lie-algebraic stability criteria for switched systems. *SIAM Journal on Control and Optimization*, 40(1):253–269, 2001.
- [4] Mohamad Alwan, Xinzhi Liu, and Brian Ingalls. Exponential stability of singularly perturbed switched systems with time delay. *Nonlinear Anal. Hybrid Syst.*, 2(3):913–921, 2008.
- [5] John F Andrews. A mathematical model for the continuous culture of microorganisms utilizing inhibitory substrates. *Biotechnology and bioengineering*, 10(6):707–723, 1968.
- [6] Vincent Andrieu and Madiha Nadri. Observer design for Lipschitz systems with discrete-time measurements. In *49th IEEE Conference on Decision and Control (CDC)*, pages 6522–6527, 2010.
- [7] Jean-Pierre Aubin. *Viability theory*. Birkhäuser, Basel, 1991.
- [8] Jean-Pierre Aubin and Patrick Saint-Pierre. An introduction to viability theory and management of renewable resources. In J. Kropp and J. Scheffran, editors, *Advanced Methods for Decision Making and Risk Management*, pages 43–80. Nova Science Publishers, 2007.
- [9] Kamel Baibeche and Claude H. Moog. Input-state feedback linearization for a class of single-input nonlinear time-delay systems. *IMA Journal of Mathematical Control and Information*, 33:873–891, 2016.
- [10] Moussa Balde, Ugo Boscain, and Paolo Mason. A note on stability conditions for planar switched systems. *Internat. J. Control*, 82(10):1882–1888, 2009.
- [11] Alim Benabid, Pierre Pollak, D. Hoffmann, C. Gervason, M. Hommel, J.E. Perret, J. De Rougemont, and D.M. Gao. Long-term suppression of tremor by chronic stimulation of the ventral intermediate thalamic nucleus. *The Lancet*, 337(8738):403–406, 1991.

- [12] Pauline Bernard, Vincent Andrieu, and Laurent Praly. Expressing an observer in preferred coordinates by transforming an injective immersion into a surjective diffeomorphism. *SIAM Journal on Control and Optimization*, 56(3):2327–2352, 2018.
- [13] Piernicola Bettiol, Hélène Frankowska, and Richard Vinter. L^∞ estimates on trajectories confined to a closed subset. *J. Differential Equations*, 252:1912–1933, 2012.
- [14] Frédéric Bonnans, Pierre Martinon, Daphné Giorgi, Vincent Grélard, Stéphan Maindault, Olivier Tissot, and Jinyan Liu. Bocop 2.0. 5—user guide. URL <http://bocop.org>, 480, 2017.
- [15] Ugo Boscain. Stability of planar switched systems: The linear single input case. *SIAM Journal on Control and Optimization*, 41(1):89–112, 2002.
- [16] Ugo Boscain. Stability of planar switched systems: the linear single input case. *SIAM J. Control Optim.*, 41(1):89–112, 2002.
- [17] Loïc Bourdin and Emmanuel Trélat. Optimal sampled-data control, and generalizations on time scales. *arXiv preprint arXiv:1501.07361*, 2015.
- [18] Sylvie Bourrel, Denis Dochain, Jean-Pierre Babary, and Isabelle Queinnec. Modelling, identification and control of a denitrifying biofilter. *Journal of process Control*, 10(1):73–91, 2000.
- [19] Michael S. Branicky. Multiple Lyapunov functions and other analysis tools for switched and hybrid systems. *IEEE Transactions on Automatic Control*, 43(4):475–482, 1998.
- [20] Delphine Bresch-Pietri, Christophe Prieur, and Emmanuel Trélat. New formulation of predictors for finite-dimensional linear control systems with input delay. *Systems & Control Letters*, 113:9–16, 2018.
- [21] Claudia Califano, Luis Alejandro Marquez-Martinez, and Claude H. Moog. Extended Lie brackets for nonlinear time-delay systems. *IEEE Transactions on Automatic Control*, 56(9):2213–2218, 2011.
- [22] Jinde Cao and Jun Wang. Global exponential stability and periodicity of recurrent neural networks with time delays. *IEEE Transactions on Circuits and Systems I: Regular Papers*, 52(5):920–931, May 2005.
- [23] Antoine Chaillet, Iasson Karafyllis, Pierdomenico Pepe, and Yuan Wang. The ISS framework for time-delay systems: a survey. *Mathematics of Control, Signals, and Systems*, pages 1–70, 2023.
- [24] Antoine Chaillet, Jakub Orłowski, and Pierdomenico Pepe. A relaxed Lyapunov-Krasovskii condition for global exponential stability of lipschitz time-delay systems. In *2019 IEEE 58th Conference on Decision and Control (CDC)*, pages 43–48. IEEE, 2019.
- [25] Yacine Chitour, Ihab Haidar, Paolo Mason, and Mario Sigalotti. Upper and lower bounds for the maximal Lyapunov exponent of singularly perturbed linear switching systems. *Automatica*, 155:111151, 2023.

- [26] Yacine Chitour and Mario Sigalotti. On the stabilization of persistently excited linear systems. *SIAM journal on control and optimization*, 48(6):4032–4055, 2010.
- [27] Francis H. Clarke. *Optimization and nonsmooth analysis*. SIAM, Philadelphia, 1990.
- [28] Jamal Daafouz, Pierre Riedinger, and Claude Iung. Stability analysis and control synthesis for switched systems: a switched Lyapunov function approach. *IEEE transactions on automatic control*, 47(11):1883–1887, 2002.
- [29] Sergey Dashkovskiy, Björn Rüffer, and Fabian Wirth. An ISS small gain theorem for general networks. *Mathematics of Control, Signals, and Systems*, 19:93–122, 2007.
- [30] Sergey Dashkovskiy, Björn Rüffer, and Fabian Wirth. Small gain theorems for large scale systems and construction of ISS lyapunov functions. *SIAM Journal on Control and Optimization*, 48(6):4089–4118, 2010.
- [31] Richard Datko. Extending a theorem of A. M. Liapunov to Hilbert space. *Journal of Mathematical Analysis and Applications*, 32:610–616, 1970.
- [32] Wijesuriya P. Dayawansa and Clyde F. Martin. A converse Lyapunov theorem for a class of dynamical systems which undergo switching. *IEEE Transactions on Automatic Control*, 44(4):751–760, 1999.
- [33] Bart De Schutter, WPMH Heemels, Jan Lunze, Christophe Prieur, et al. Survey of modeling, analysis, and control of hybrid systems. *Handbook of Hybrid Systems Control—Theory, Tools, Applications*, pages 31–55, 2009.
- [34] Jacques Descusse and Claude H. Moog. Decoupling with dynamic compensation for strong invertible affine non-linear systems. *International Journal of Control*, 43(6):1387–1398, 1985.
- [35] Georgios Is Detorakis, Antoine Chaillet, Stéphane Palfi, and Suhan Senova. Closed-loop stimulation of a delayed neural fields model of parkinsonian STN-GPe network: a theoretical and computational study. *Frontiers in neuroscience*, 9:237, 2015.
- [36] Denis Dochain. *Automatic control of bioprocesses*. John Wiley & Sons, 2013.
- [37] Rodney D. Driver. Existence and stability of solutions of a delay-differential system. *Archive for Rational Mechanics and Analysis*, 10(1):401–426, 1962.
- [38] Fouad El Hachemi, Mario Sigalotti, and Jamal Daafouz. Stability analysis of singularly perturbed switched linear systems. *IEEE Trans. Automat. Control*, 57(8):2116–2121, 2012.
- [39] Maurizio Falcone and Patrick Saint-Pierre. Slow and quasi-slow solutions of differential inclusions. *Nonlinear Analysis: Theory, Methods & Applications*, 11(3):367 – 377, 1987.
- [40] Aleksei F. Filippov. Classical solutions of differential equations with multivalued right hand side. *SIAM J. Control Optimal*, 5:609–621, 1967.

- [41] Michel Fliess and Hugues Mounier. Controllability and observability of linear delay systems : an algebraic approach. *ESAIM: Control Optimization and Calculus Variation*, 3:301–314, 1998.
- [42] Francesca Forcellini and Franco Rampazzo. On nonconvex differential inclusions whose state is constrained in the closure of an open set. applications to dynamic programming. *J. Differential and Integral Equations*, 12(4):471–497, 1999.
- [43] H el ene Frankowska and Ihab Haidar. A relaxation result for state-constrained delay differential inclusions. *IEEE Transactions on Automatic Control*, 63(11):3751–3760, 2018.
- [44] H el ene Frankowska and Ihab Haidar. Viable trajectories for nonconvex differential inclusions with constant delay. *IFAC-PapersOnLine*, 51(14):112–117, 2018.
- [45] H el ene Frankowska, Elsa M. Marchini, and Marco Mazzola. A relaxation result for state constrained inclusions in infinite dimension. *Mathematical Control and Related Fields*, 6(1):113–141, 2016.
- [46] H el ene Frankowska and Marco Mazzola. Discontinuous solutions of Hamilton-Jacobi-Bellman equation under state constraints. *Calculus of Variations and Partial Differential Equations*, 46:725–747, 2013.
- [47] H el ene Frankowska and Marco Mazzola. On relations of the adjoint state to the value function for optimal control problems with state constraints. *Nonlinear Differential Equations and Applications*, 20:361–383, 2013.
- [48] H el ene Frankowska and Marc Quincampoix. Viability kernels of differential inclusions with constraints: algorithm and applications. *J. Math. Systems, Estimation and Control*, 1:371–388, 1991.
- [49] H el ene Frankowska and Franco Rampazzo. Filippov’s and Filippov–Wazewski’s theorems on closed domains. *J. Differential Equations*, 161:449–478, 2000.
- [50] H el ene Frankowska and Richard B. Vinter. Existence of neighboring feasible trajectories: Applications to dynamic programming for state-constrained optimal control problems. *J. Optimization Theory and Applications*, 104(1):21–40, 2000.
- [51] Emilia Fridman. A refined input delay approach to sampled-data control. *Automatica*, 46(2):421–427, 2010.
- [52] Emilia Fridman. *Introduction to time-delay systems: Analysis and control*. Basel, Switzerland: Birkh auser, 2014.
- [53] Emilia Fridman, Michel Dambrine, and Nima Yeganefar. On input-to-state stability of systems with time-delay: A matrix inequalities approach. *Automatica*, 44(9):2364–2369, 2008.
- [54] Germain Garcia, Jamal Daafouz, and Jacques Bernussou. H_2 guaranteed cost control for singularly perturbed uncertain systems. *IEEE transactions on Automatic Control*, 43(9):1323–1329, 1998.

- [55] Jean-Paul Gauthier, Hassan Hammouri, and Sami Othman. A simple observer for nonlinear systems applications to bioreactors. *IEEE Transactions on automatic control*, 37(6):875–880, 1992.
- [56] Jean-Paul Gauthier and Ivan Kupka. *Deterministic observation theory and applications*. Cambridge university press, 2001.
- [57] Alfredo Germani, Costanzo Manes, and Pierdomenico Pepe. Input-output linearization with delay cancellation for nonlinear delay systems: the problem of the internal stability. *International Journal of Robust and Nonlinear Control*, 13(9):909–937, 2003.
- [58] Dimitri Giunchi, Yuri V Albores-Barajas, N Emilio Baldaccini, Lorenzo Vanni, and Cecilia Soldatini. Feral pigeons: problems, dynamics and control methods. *Integrated pest management and pest control. Current and future tactics, London, InTechOpen*, pages 215–240, 2012.
- [59] Antonio R. Granata and S. T. Kitai. Intracellular analysis of excitatory subthalamic inputs to the pedunculopontine neurons. *Brain research*, 488(1-2):57–72, 1989.
- [60] JE Haag, Alain Vande Wouwer, and Isabelle Queinnec. Macroscopic modelling and identification of an anaerobic waste treatment process. *Chemical Engineering Science*, 58(19):4307–4316, 2003.
- [61] Georges Haddad. Monotone viable trajectories for functional differential inclusions. *J. Differential Equations*, 42:1–24, 1981.
- [62] John W. Hagoood and Brian S. Thomson. Recovering a function from a Dini derivative. *American Mathematical Monthly*, 113(1):34–46, 2006.
- [63] Ihab Haidar. *Mathematical modeling and analysis of soil microbial dynamics*. Ph.D. thesis, University Montpellier, 2011.
- [64] Ihab Haidar. Non-coercive Lyapunov–Krasovskii functionals for exponential stability of time-varying delay systems: a switched system approach. In *2022 10th International Conference on Systems and Control (ICSC)*, pages 18–22, 2022.
- [65] Ihab Haidar, Isabelle Alvarez, and Anne-Caroline Prévot. Mathematical modeling of an urban pigeon population subject to local management strategies. *Mathematical Biosciences*, 288:71 – 83, 2017.
- [66] Ihab Haidar, Jean-Pierre Barbot, and Alain Rapaport. A multi observers approach when observability index is higher than the state dimension—a case study. In *2019 IEEE 58th Conference on Decision and Control (CDC)*, pages 1571–1576. IEEE, 2019.
- [67] Ihab Haidar, Jean-Pierre Barbot, and Alain Rapaport. Illustration of the application of the multi-observers approach. In *2021 9th International Conference on Systems and Control (ICSC)*, pages 249–251. IEEE, 2021.
- [68] Ihab Haidar, Jean Pierre Barbot, and Alain Rapaport. A multi-observers approach for a class of bidimensional non-uniformly observable systems. *IEEE Transactions on Automatic Control*, 2022.

- [69] Ihab Haidar, Jean-Pierre Barbot, Alain Rapaport, and Malek Ghanes. Observability singularity of batch bioreactors: A solution based on high order sliding mode differentiator approach. In *2017 11th Asian Control Conference (ASCC)*, pages 336–338. IEEE, 2017.
- [70] Ihab Haidar, Yacine Chitour, Paolo Mason, and Mario Sigalotti. Converse Lyapunov theorems for infinite-dimensional nonlinear switching systems. In *2019 IEEE 58th Conference on Decision and Control (CDC)*, pages 587–592. IEEE, 2019.
- [71] Ihab Haidar, Yacine Chitour, Paolo Mason, and Mario Sigalotti. Lyapunov characterization of uniform exponential stability for nonlinear infinite-dimensional systems. *IEEE Transactions on Automatic Control*, 2021.
- [72] Ihab Haidar, Elie Desmond-Le Quéméner, Jean-Pierre Barbot, Jérôme Harmand, and Alain Rapaport. Modeling and optimal control of an electro-fermentation process within a batch culture. *Processes*, 10(3):535, 2022.
- [73] Ihab Haidar, Frédéric Gérard, and Alain Rapaport. Comparison of numerical simulations of reactive transport and chemostat-like models. *Computational Ecology and Software*, 1(4):249–265, 2011.
- [74] Ihab Haidar, Paolo Mason, Silviu-Iulian Niculescu, Mario Sigalotti, and Antoine Chaillet. Further remarks on Markus-Yamabe instability for time-varying delay differential equations. *IFAC-PapersOnLine*, 48(12):33–38, 2015.
- [75] Ihab Haidar, Paolo Mason, and Mario Sigalotti. Converse Lyapunov–Krasovskii theorems for uncertain time–delay systems. In *Proc. of the 19th IFAC World Congress*, 19:10096–10100, 2014.
- [76] Ihab Haidar, Paolo Mason, and Mario Sigalotti. Converse Lyapunov–Krasovskii theorems for uncertain retarded differential equations. *Automatica*, 62:263–273, 2015.
- [77] Ihab Haidar, Paolo Mason, and Mario Sigalotti. Stability of interconnected uncertain delay systems: a converse Lyapunov approach. *Delays and Interconnections: Methodology, Algorithms and Applications*, pages 49–63, 2019.
- [78] Ihab Haidar, Florentina Nicolau, Jean-Pierre Barbot, and Woihida Aggoune. Further remarks on input-output linearization of siso time-varying delay systems. In *SIAM Conference on Control and its Applications, Pittsburgh Pennsylvania, USA*, pages 33–39, 2017.
- [79] Ihab Haidar, Florentina Nicolau, Jean-Pierre Barbot, and Woihida Aggoune. Input-output linearization of siso nonlinear time-varying delay systems. In *the 20th World Congress of the International Federation of Automatic Control (IFAC), Toulouse, France*, volume 50, pages 13300–13305, 2017.
- [80] Ihab Haidar, Florentina Nicolau, Jean-Pierre Barbot, and Woihida Aggoune. Input-output linearization of non-linear time-varying delay systems: the single-input single-output case. *IMA Journal of Mathematical Control and Information*, 37(3):831–854, 11 2019.

- [81] Ihab Haidar, William Pasillas-Lépine, Antoine Chaillet, Elena Panteley, Stéphane Palfi, and Suhan Senova. Closed-loop firing rate regulation of two interacting excitatory and inhibitory neural populations of the basal ganglia. *Biological cybernetics*, 110(1):55–71, 2016.
- [82] Ihab Haidar, William Pasillas-Lépine, Elena Panteley, and Antoine Chaillet. Basal ganglia oscillations: the role of delays and external excitatory nuclei. In *2013 European Control Conference (ECC)*, pages 4083–4088. IEEE, 2013.
- [83] Ihab Haidar, William Pasillas-Lépine, Elena Panteley, Antoine Chaillet, Stéphane Palfi, and Suhan Senova. Analysis of delay-induced basal ganglia oscillations: the role of external excitatory nuclei. *International Journal of Control*, 87(9):1936–1956, 2014.
- [84] Ihab Haidar and Pierdomenico Pepe. Lyapunov–Krasovskii characterizations of stability notions for switching retarded systems. *IEEE Transactions on Automatic Control*, 2020.
- [85] Ihab Haidar and Pierdomenico Pepe. Lyapunov–Krasovskii characterization of the input-to-state stability for switching retarded systems. *SIAM Journal on Control and Optimization*, 59(4):2997–3016, 2021.
- [86] Ihab Haidar and Pierdomenico Pepe. Iss characterization of retarded switching systems with relaxed Lyapunov–Krasovskii functionals. In *2022 IEEE 61st Conference on Decision and Control (CDC)*, pages 6242–6247. IEEE, 2022.
- [87] Ihab Haidar, Alain Rapaport, and Frédérique Gérard. Effects of spatial structure and diffusion on the performances of the chemostat. *Math. Biosci. Eng.*, 8(4):953–971, 2011.
- [88] Jack K. Hale and Sjoerd M. Verduyn Lunel. *Introduction to functional differential equations*, volume 99. Springer-Verlag, 1993.
- [89] Clement Hamani, Jean A. Saint-Cyr, Justin Fraser, Michael Kaplitt, and Andres M. Lozano. The subthalamic nucleus in the context of movement disorders. *Brain*, 127(1):4–20, 2004.
- [90] Constance Hammond, Hagai Bergman, and Peter Brown. Pathological synchronization in parkinson’s disease: networks, models and treatments. *Trends in neurosciences*, 30(7):357–364, 2007.
- [91] Falk M. Hante and Mario Sigalotti. Converse Lyapunov theorems for switched systems in Banach and Hilbert spaces. *SIAM Journal on Control and Optimization*, 49(2):752–770, 2011.
- [92] Jérôme Harmand, Claude Lobry, Alain Rapaport, and Tewfik Sari. *The chemostat: Mathematical theory of microorganism cultures*. John Wiley & Sons, 2017.
- [93] Jérôme Harmand, Claude Lobry, Alain Rapaport, and Tewfik Sari. *Optimal Control in Bioprocesses: Pontryagin’s Maximum Principle in Practice*. John Wiley & Sons, 2019.
- [94] Joao P. Hespanha and A. Stephen Morse. Stability of switched systems with average dwell-time. In *Proceedings of the 38th IEEE conference on decision and control (Cat. No. 99CH36304)*, volume 3, pages 2655–2660. IEEE, 1999.

- [95] Laurentiu Hetel, Jamal Daafouz, and Claude Iung. Equivalence between the Lyapunov–Krasovskii functional approach for discrete delay systems and the stability conditions for switched systems. *Nonlinear Analysis: Hybrid Systems*, 2(3):697–705, 2008.
- [96] Laurentiu Hetel, Christophe Fiter, Hassan Omran, Alexandre Seuret, Emilia Fridman, Jean-Pierre Richard, and Silviu Iulian Niculescu. Recent developments on the stability of systems with aperiodic sampling: An overview. *Automatica*, 76:309–335, 2017.
- [97] Alberto Isidori, Arthur Krener, Claudio Gori-Giorgi, and Salvatore Monaco. Nonlinear decoupling via feedback: a differential geometric approach. *IEEE transactions on automatic control*, 26(2):331–345, 1981.
- [98] Birgit Jacob, Andrii Mironchenko, Jonathan R Partington, and Fabian Wirth. Noncoercive Lyapunov functions for input-to-state stability of infinite-dimensional systems. *SIAM Journal on Control and Optimization*, 58(5):2952–2978, 2020.
- [99] Lisa Jacquin, Bernard Cazelles, Anne-Caroline Prévot, Gerard Leboucher, and Julien Gasparini. Reproduction management affects breeding ecology and reproduction costs in feral urban pigeons (*columba livia*). *Canadian Journal of Zoology*, 88(8):781–787, 2010.
- [100] Bronislaw Jakubczyk and Witold Respondek. On linearization of control systems. *Bulletin L’Académie Polonaise des Science, Série des Sciences Mathématiques*, pages 517–522, 1980.
- [101] Ned Jenkinson and Peter Brown. New insights into the relationship between dopamine, beta oscillations and motor function. *Trends in neurosciences*, 34(12):611–618, 2011.
- [102] Marc Jungers and Jamal Daafouz. Guaranteed cost certification for discrete-time linear switched systems with a dwell time. *IEEE Transactions on Automatic Control*, 58(3):768–772, 2012.
- [103] Iasson Karafyllis and Costas Kravaris. From continuous-time design to sampled-data design of observers. *IEEE Transactions on Automatic Control*, 54(9):2169–2174, 2009.
- [104] Iasson Karafyllis and Miroslav Krstic. Nonlinear stabilization under sampled and delayed measurements, and with inputs subject to delay and zero-order hold. *IEEE Transactions on Automatic Control*, 57(5):1141–1154, 2012.
- [105] Iasson Karafyllis and Miroslav Krstic. Sampled-data boundary feedback control of 1-D parabolic PDEs. *Automatica*, 87:226–237, 2018.
- [106] Iasson Karafyllis, Pierdomenico Pepe, and Zhong P. Jiang. Global output stability for systems described by retarded functional differential equations: Lyapunov characterizations. *European Journal of Control*, 14:516–536, 2008.
- [107] Iasson Karafyllis, Pierdomenico Pepe, and Zhong P. Jiang. Input-to-output stability for systems described by retarded functional differential equations. *European Journal of Control*, 14:539–555, 2008.

- [108] Christoph Kawan, Andrii Mironchenko, Abdalla Swikir, Navid Noroozi, and Majid Zamani. A Lyapunov-based small-gain theorem for infinite networks. *IEEE Transactions on Automatic Control*, 66(12):5830–5844, 2020.
- [109] Jonathan W. Kimball and Philip T. Krein. Singular perturbation theory for DC-DC converters and application to PFC converters. In *2007 IEEE Power Electronics Specialists Conference*, pages 882–887, 2007.
- [110] Shumon Koga, Iasson Karafyllis, and Miroslav Krstic. Sampled-data control of the Stefan system. Preprint Arxiv 1906.01434.
- [111] Petar Kokotović, Hassan K. Khalil, and John O’Reilly. *Singular perturbation methods in control*, volume 25 of *Classics in Applied Mathematics*. Society for Industrial and Applied Mathematics (SIAM), Philadelphia, PA, 1999. Analysis and design, Corrected reprint of the 1986 original.
- [112] Vladimir B. Kolmanovskii and Anatoliy Myshkis. *Introduction to the theory and applications of functional differential equations*, volume . Dordrecht: Kluwer Academy, 1999.
- [113] Nikolay N. Krasovskii. *Stability of motion*. Stanford University Press, 1963.
- [114] Rajeev Kumar, Andres M Lozano, Elspeth Sime, and Anthony E Lang. Long-term follow-up of thalamic deep brain stimulation for essential and parkinsonian tremor. *Neurology*, 61(11):1601–1604, 2003.
- [115] Ramon Leyva, Corinne Alonso, Isabelle Queinnec, Angel Cid-Pastor, Denis Lagrange, and Luis Martinez-Salamero. MPPT of photovoltaic systems using extremum-seeking control. *IEEE transactions on aerospace and electronic systems*, 42(1):249–258, 2006.
- [116] Hugo Lhachemi, Christophe Prieur, and Robert Shorten. An LMI condition for the robustness of constant-delay linear predictor feedback with respect to uncertain time-varying input delays. *Automatica*, 109:108551, 2019.
- [117] Daniel Liberzon. *Switching in systems and control, systems and control: Foundations and applications*. Birkhäuser, Boston, 2003.
- [118] Daniel Liberzon and A. Stephen Morse. Basic problems in stability and design of switched systems. *IEEE Control Systems*, 19(5):59–70, 1999.
- [119] Hartmut Logemann, Richard Rebarber, and Stuart Townley. Stability of infinite-dimensional sampled-data systems. *Transactions of the American Mathematical Society*, pages 3301–3328, 2003.
- [120] R. W. Lovitt and Julian W.T. Wimpenny. The gradostat: a bidirectional compound chemostat and its application in microbiological research. *Microbiology*, 127(2):261–268, 1981.
- [121] Mariem Makni, Ihab Haidar, Jean-Pierre Barbot, and Franck Plestan. Active fault-tolerant control based on sparse recovery diagnosis: The twin wind turbines case. *International Journal of Robust and Nonlinear Control*, 2022.

- [122] Mariem Makni, Ihab Haidar, Jean-Pierre Barbot, and Franck Plestan. Active fault tolerant control through sparse recovery diagnosis. In *2022 10th International Conference on Systems and Control (ICSC)*, pages 178–183. IEEE, 2022.
- [123] Mariem Makni, Ihab Haidar, Jean-Pierre Barbot, Franck Plestan, Nabih Feki, and Mohamed Slim Abbas. Analysis and control of twin wind turbine subject to asymmetric fault. In *2020 IEEE Conference on Control Technology and Applications (CCTA)*, pages 1–6. IEEE, 2020.
- [124] Mariem Makni, Ihab Haidar, Jean-Pierre Barbot, Franck Plestan, Nabih Feki, and Mohamed Slim Abbas. Active fault tolerant control for twin wind turbine subject to asymmetric fault. In *2021 International Conference on Control, Automation and Diagnosis (ICCAD)*, pages 1–6. IEEE, 2021.
- [125] Mariem Makni, Ihab Haidar, Jean-Pierre Barbot, Franck Plestan, Nabih Feki, and Mohamed Slim Abbas. Observer-based active fault-tolerant control of an asymmetric twin wind turbine. *Information*, 13(3):113, 2022.
- [126] Ivan Mallocci, Jamal Daafouz, and Claude Iung. Stabilization of continuous-time singularly perturbed switched systems. In *Proceedings of the 48th IEEE Conference on Decision and Control (CDC) held jointly with 2009 28th Chinese Control Conference*, pages 6371–6376, 2009.
- [127] Ivan Mallocci, Jamal Daafouz, Claude Iung, Rémi Bonidal, and Patrick Szczepanski. Switched system modeling and robust steering control of the tail end phase in a hot strip mill. *Nonlinear analysis: hybrid systems*, 3(3):239–250, 2009.
- [128] Jose L. Mancilla-Aguilar and R.A. García. On converse Lyapunov theorems for ISS and iISS switched nonlinear systems. *Systems & Control Letters*, 42(1):47–53, 2001.
- [129] Jose L. Mancilla-Aguilar and Ronaldo A. García. A converse Lyapunov theorem for nonlinear switched systems. *Systems & Control Letters*, 41(1):67–71, 2000.
- [130] Lawrence Markus and Hidehiko Yamabe. Global stability criteria for differential systems. *Osaka Mathematical Journal*, 12(2):305–317, 1960.
- [131] Patrick Martinez. Precise decay rate estimates for time-dependent dissipative systems. *Israel Journal of Mathematics*, 119(1):291–324, 2000.
- [132] Paolo Mason, Ugo Boscain, and Yacine Chitour. Common polynomial Lyapunov functions for linear switched systems. *SIAM Journal on Control and Optimization*, 45(1):226–245, 2006.
- [133] Frédéric Mazenc, Vincent Andrieu, and Michael Malisoff. Continuous-discrete observers for time-varying nonlinear systems: A tutorial on recent results. In *Proceedings of the SIAM Conference on Control and its Applications*, pages 181–188, 2015.
- [134] Frédéric Mazenc and Emilia Fridman. Predictor-based sampled-data exponential stabilization through continuous–discrete observers. *Automatica*, 63:74–81, 2016.

- [135] Juan Mena-Segovia, J. Paul Bolam, and Peter J. Magill. Pedunculopontine nucleus and basal ganglia: distant relatives or part of the same family? *Trends in neurosciences*, 27(10):585–588, 2004.
- [136] Andrii Mironchenko and Christophe Prieur. Input-to-state stability of infinite-dimensional systems: recent results and open questions. *SIAM Review*, 62(3):529–614, 2020.
- [137] Andrii Mironchenko and Fabian Wirth. Characterizations of input-to-state stability for infinite-dimensional systems. *IEEE Transactions on Automatic Control*, 63(6):1692–1707, 2017.
- [138] Andrii Mironchenko and Fabian Wirth. Lyapunov characterization of input-to-state stability for semilinear control systems over Banach spaces. *Systems & Control Letters*, 119:64–70, 2018.
- [139] Andrii Mironchenko and Fabian Wirth. Existence of non-coercive Lyapunov functions is equivalent to integral uniform global asymptotic stability. *Mathematics of Control, Signals, and Systems*, 31(2):1–26, 2019.
- [140] Andrii Mironchenko and Fabian Wirth. Non-coercive Lyapunov functions for infinite-dimensional systems. *Journal of Differential Equations*, 266(11):7038–7072, 2019.
- [141] Isao Miyadera. *Nonlinear Semigroups*, volume 109. American Mathematical Society, Providence, RI, 1991.
- [142] Jacques Monod. La technique de culture continue: theorie et applications. *Selected Papers in Molecular Biology by Jacques Monod*, 79:390–410, 1950.
- [143] Roman Moscoviz, Desmond-Le Quémener, Eric Trably, Nicolas Bernet, et al. Bioelectrochemical systems for the valorization of organic residues. In *Biorefinery*, pages 511–534. Springer, 2019.
- [144] Roman Moscoviz, Javiera Toledo-Alarcón, Eric Trably, and Nicolas Bernet. Electrofermentation: how to drive fermentation using electrochemical systems. *Trends in biotechnology*, 34(11):856–865, 2016.
- [145] Roman Moscoviz, Eric Trably, and Nicolas Bernet. Electro-fermentation triggering population selection in mixed-culture glycerol fermentation. *Microbial biotechnology*, 11(1):74–83, 2018.
- [146] Raúl Naulin and Carlos Pabst. The roots of a polynomial depend continuously on its coefficients. *Revista colombiana de matemáticas*, 28(1):35–37, 1994.
- [147] Alejo J. Nevado-Holgado, John R. Terry, and Rafal Bogacz. Conditions for the generation of beta oscillations in the subthalamic nucleus–globus pallidus network. *Journal of Neuroscience*, 30(37):12340–12352, 2010.
- [148] Florentina Nicolau, Ihab Haidar, Jean-Pierre Barbot, and Woihida Aggoune. Input-output decoupling and linearization of nonlinear two-input two-output time-varying delay systems. In *the 23rd International Symposium on Mathematical Theory of Networks and Systems (MTNS), Hong Kong, China*, pages 302–308, 2018.

- [149] Florentina Nicolau, Ihab Haidar, Jena-Pierre Barbot, and Woihida Aggoune. Input-output decoupling and linearization of nonlinear multi-input multi-output time-varying delay systems. *IFAC-PapersOnLine*, 53(2):5771–5776, 2020.
- [150] Silviu I. Niculescu. *Delay effects on stability: A robust control approach*, volume 269. Berlin: Springer, 2001.
- [151] Aaron Novick and Leo Szilard. Description of the chemostat. *Science*, 112(2920):715–716, 1950.
- [152] Toshiki Oguchi, Atsushi Watanabe, and Takayoshi Nakamizo. Input-output linearization of retarded non-linear systems by using an extension of lie derivative. *International Journal of Control*, 75(8):582–590, 2002.
- [153] Miles S. Okino and Michael L. Mavrovouniotis. Simplification of mathematical models of chemical reaction systems. *Chemical reviews*, 98(2):391–408, 1998.
- [154] William Pasillas-Lépine, Ihab Haidar, Antoine Chaillet, and Elena Panteley. Closed-loop Deep Brain Stimulation Based on Firing-rate Regulation. *6th International IEEE EMBS Conference on Neural Engineering*, pages 1–4, November 2013.
- [155] Alex Pavlides, S. John Hogan, and Rafal Bogacz. Improved conditions for the generation of beta oscillations in the subthalamic nucleus-globus pallidus network. *European Journal of Neuroscience*, 36:2229–2239, 2012.
- [156] Amnon Pazy. On the applicability of Lyapunov’s theorem in Hilbert space. *SIAM Journal on Mathematical Analysis*, 3(2):291–294, 1972.
- [157] Amnon Pazy. *Semigroups of Linear Operators and Applications to Partial Differential Equations*. Springer-Verlag, New York, 1983.
- [158] Pierdomenico Pepe. On Liapunov-Krasovskii functionals under Carathéodory conditions. *Autom.*, 43:701–706, 2007.
- [159] Pierdomenico Pepe and Emilia Fridman. On global exponential stability preservation under sampling for globally Lipschitz time-delay systems. *Automatica*, 82:295–300, 2017.
- [160] Pierdomenico Pepe and Zhong P. Jiang. A Lyapunov-Krasovskii methodology for ISS and iISS of time-delay systems. *Systems & Control Letters*, 55(12):1006–1014, 2006.
- [161] Pierdomenico Pepe and Iasson Karafyllis. Converse Lyapunov–Krasovskii theorems for systems described by neutral functional differential equations in Hale’s form. *International Journal of Control*, 86(2):232–243, 2013.
- [162] Pierdomenico Pepe, Iasson Karafyllis, and Zhong P. Jiang. Lyapunov–Krasovskii characterization of the input-to-state stability for neutral systems in Hale’s form. *Systems & Control Letters*, 102:48–56, 2017.
- [163] Cristina Pignotti and Emmanuel Trélat. Convergence to consensus of the general finite-dimensional cucker-smale model with time-varying delays. *arXiv preprint arXiv:1707.05020*, 2017.

- [164] S. John Pirt et al. *Principles of microbe and cell cultivation*. Blackwell Scientific Publications, 1975.
- [165] Christophe Prieur, Antoine Girard, and Emmanuel Witrant. Stability of switched linear hyperbolic systems by Lyapunov techniques. *IEEE Transactions on Automatic Control*, 59(8):2196–2202, 2014.
- [166] Christophe Prieur and Emmanuel Trélat. Feedback stabilization of a 1-D linear reaction–diffusion equation with delay boundary control. *IEEE Transactions on Automatic Control*, 64(4):1415–1425, 2018.
- [167] Alban Quadrat and Rosane Ushirobira. Algebraic analysis for the ore extension ring of differential time-varying delay operators. In *22nd International Symposium on Mathematical Theory of Networks and Systems (MTNS)*, page 8, 2016.
- [168] Isabelle Queinnec, Sophie Tarbouriech, Germain Garcia, and Silviu-Iulian Niculescu. *Biology and control theory: current challenges*, volume 357. Springer, 2007.
- [169] Alain Rapaport and Denis Dochain. A robust asymptotic observer for systems that converge to unobservable states—a batch reactor case study. *IEEE Transactions on Automatic Control*, 65(6):2693–2699, 2019.
- [170] Alain Rapaport, Ihab Haidar, and Jérôme Harmand. Global dynamics of the buffered chemostat for a general class of response functions. *Journal of Mathematical Biology*, 71(1):69–98, 2015.
- [171] Alain Rapaport and Abdelmalek Maloum. Design of exponential observers for nonlinear systems by embedding. *International Journal of Robust and Nonlinear Control*, 14(3):273–288, 2004.
- [172] Boris S. Razumikhin. *On the stability of systems with a delay*. Prikl. Mat. Meh. (in Russian), 1956.
- [173] Jean-Pierre Richard. Time-delay systems: An overview of some recent advances and open problems. *Automatica*, 39:1667–1694, 2003.
- [174] Pierre Riedinger, Mario Sigalotti, and Jamal Daafouz. On the algebraic characterization of invariant sets of switched linear systems. *Automatica*, 46(6):1047–1052, 2010.
- [175] Juan Rivas, David Perreault, and Thomas Keim. Performance improvement of alternators with switched-mode rectifiers. *IEEE Transactions on Energy Conversion*, 19(3):561–568, 2004.
- [176] Boris Rosin, Maya Slovik, Rea Mitelman, Michal Rivlin-Etzion, Suzanne N Haber, Zvi Israel, Eilon Vaadia, and Hagai Bergman. Closed-loop deep brain stimulation is superior in ameliorating parkinsonism. *Neuron*, 72(2):370–384, 2011.
- [177] Jean-Baptiste Rouquier, Isabelle Alvarez, Romain Reuillon, and Pierre-Henri Wuillemin. A kd-tree algorithm to discover the boundary of a black box hypervolume: Or how to peel potatoes by recursively cutting them in halves. *Annals of Mathematics and Artificial Intelligence*, 75:335–350, 2015.

- [178] Patrick Saint-Pierre. Approximation of the viability kernel. *Applied Mathematics & Optimisation*, 29(2):187–209, 1994.
- [179] Pontryagin Lev Semenovich. *The mathematical theory of optimal processes / L. S. Pontryagin, V. G. Boltyanskii, R. V. Gamkrelidze, E.F. Mishchenko ; translated by D. E. Brown*. International series of monographs in pure and applied mathematics. Pergamon Press MacMillan, Oxford Paris [etc.] New York, 1964.
- [180] Robert Shorten, Fabian Wirth, Oliver Mason, Kai Wulff, and Christopher King. Stability criteria for switched and hybrid systems. *SIAM review*, 49(4):545–592, 2007.
- [181] Mariette Sicard, Nathalie Perrot, Romain Reuillon, Salma Mesmoudi, Isabelle Alvarez, and Sophie Martin. A viability approach to control food processes: Application to a camembert cheese ripening process. *Food Control*, 23(2):312–319, 2012.
- [182] Ivan S. Simeonov, Danka Galabova, and Isabelle Queinnec. Investigations and mathematical modelling of the anaerobic digestion of organic wastes with addition of electron acceptors. In *Proc. 9th World Congress “Anaerobic Digestion*, pages 381–383, 2001.
- [183] Ivan S. Simeonov and Isabelle Queinnec. Linearizing control of the anaerobic digestion with addition of acetate (control of the anaerobic digestion). *control engineering Practice*, 14(7):799–810, 2006.
- [184] Hal L. Smith and Paul Waltman. *The theory of the chemostat: dynamics of microbial competition*, volume 13. Cambridge university press, 1995.
- [185] Eduardo D. Sontag and Yuan Wang. On characterizations of the input-to-state stability property. *Systems & Control Letters*, 24(5):351–359, 1995.
- [186] Andrew R. Teel. Connections between Razumikhin-type theorems and the ISS nonlinear small gain theorem. *IEEE Transactions on Automatic Control*, 43(7):960–964, 1998.
- [187] Andrew R. Teel. Connections between Razumikhin-type theorems and the ISS nonlinear small gain theorem. *IEEE Transactions on Automatic Control*, 43(7):960–964, 1998.
- [188] Alexander Tolstonogov. *Differential inclusions in a Banach space*. Springer, 2012.
- [189] Emmanuel Trélat. *Contrôle optimal: théorie & applications*, volume 36. Vuibert Paris, 2005.
- [190] Masashi Wakaiki and Yutaka Yamamoto. Stability analysis of perturbed infinite-dimensional sampled-data systems. *Systems Control Lett.*, 138:104652, 8, 2020.
- [191] Glenn F. Webb. Autonomous nonlinear functional differential equations and nonlinear semigroups. *Journal of Mathematical Analysis and Applications*, 46(1):1–12, 1974.
- [192] Fabian Wirth. A converse Lyapunov theorem for linear parameter-varying and linear switching systems. *SIAM Journal on Control and Optimization*, 44(1):210–239, 2005.
- [193] Emmanuel Witrant, Emilia Fridman, Olivier Sename, and Luc Dugard. *Recent results on time-delay systems: Analysis and control*, volume 5. Springer, 2016.

-
- [194] Nima Yeganefar, Pierdomenico Pepe, and Michel Dambrine. Input-to-state stability of time-delay systems: a link with exponential stability. *IEEE Transactions on Automatic Control*, 53(6):1526–1531, 2008.
- [195] Michail I. Zelikin and Vladimir F Borisov. *Theory of chattering control: with applications to astronautics, robotics, economics, and engineering*. Springer Science & Business Media, 2012.
- [196] Dianli Zhao and Haidong Liu. Coexistence in a two species chemostat model with markov switchings. *Applied Mathematics Letters*, 94:266–271, 2019.