



HAL
open science

Extended Vuza canons

Greta Lanzarotto

► **To cite this version:**

Greta Lanzarotto. Extended Vuza canons. General Mathematics [math.GM]. Université de Strasbourg; Università degli studi di Milano - Bicocca; Università degli studi (Pavie, Italie), 2022. English. NNT : 2022STRAD013 . tel-03843916v2

HAL Id: tel-03843916

<https://hal.science/tel-03843916v2>

Submitted on 28 Jan 2023

HAL is a multi-disciplinary open access archive for the deposit and dissemination of scientific research documents, whether they are published or not. The documents may come from teaching and research institutions in France or abroad, or from public or private research centers.

L'archive ouverte pluridisciplinaire **HAL**, est destinée au dépôt et à la diffusion de documents scientifiques de niveau recherche, publiés ou non, émanant des établissements d'enseignement et de recherche français ou étrangers, des laboratoires publics ou privés.

ÉCOLE DOCTORALE 269 « Mathématiques, Sciences de l'Information et de l'Ingénieur »

Institut de Recherche Mathématique Avancée (IRMA)

THÈSE présentée par :

Greta LANZAROTTO

soutenue le : **29 septembre 2022**

pour obtenir le grade de : **Docteur de l'université de Strasbourg**

per ottenere il titolo di : **Dottore di Ricerca**

Discipline / Spécialité : **Mathématiques**

EXTENDED VUZA CANONS

THÈSE dirigée par :

M. ANDREATTA Moreno

M. PERNAZZA Ludovico

Directeur de Recherche, Université de Strasbourg

Chercheur, Università degli Studi di Pavia

RAPPORTEURS :

M. JEDRZEJSKI Franck

M. AGON Carlos

Chargé de Recherches, Université de Paris-Saclay

PR PUPH, Sorbonne Université

AUTRES MEMBRES DU JURY :

Mme FIOROT Luisa

M. AMIOT Emmanuel

M. TONOLO Alberto

Directeur de Recherche, Università degli Studi di Padova

Expert dans la matière, Université de Perpignan

Directeur de Recherche, Università degli Studi di Padova



UNIVERSITÀ DEGLI STUDI
DI MILANO
BICOCCA

Université
de Strasbourg

SCUOLA DI DOTTORATO
UNIVERSITÀ DEGLI STUDI
DI PAVIA E
DI MILANO-BICOCCA

Dipartimenti di
MATEMATICA
E APPLICAZIONI

Ph.D. program in MATHEMATICS

ÉCOLE DOCTORALE
DE MATHÉMATIQUES, SCIENCES DE
L'INFORMATION ET DE L'INGÉNIEUR
UNIVERSITÉ DE STRASBOURG

Institut de
RECHERCHE
MATHÉMATIQUE AVANCÉE

Cycle XXXIV

EXTENDED VUZA CANONS

Surname: LANZAROTTO Name: GRETA

Registration number: 847623

Tutor: Prof. PERNAZZA LUDOVICO

Co-tutor: Prof. ANDREATTA MORENO

Coordinator: Prof. COLLI PIERLUIGI

ACADEMIC YEAR 2020/2021

Canons de Vuza étendus

Résumé de la thèse de doctorat

Greta Lanzarotto

1 Introduction

Le lien entre musique et mathématiques a été découvert et étudié depuis l'Antiquité par de nombreux scientifiques, philosophes, musiciens tels que Pythagore, Galileo Galilei, Gottfried Wilhelm Leibniz et Leonhard Euler. À première vue, deux domaines diamétralement opposés, au fil des siècles, la musique et les mathématiques se sont révélées avoir beaucoup en commun. Cette thèse découle de la volonté d'approfondir un thème qui puise des concepts dans les deux disciplines et de la conviction que l'étude combinée des deux ne peut que profiter aux deux côtés de la relation.

Dans cette thèse, nous traitons des canons rythmique de pavage, qui sont des compositions contrapuntiques purement rythmiques. Les canons en musique ont une très longue tradition ; quelques cas de canons rythmiques de pavage (c'est-à-dire des canons tels que, étant donné un tempo fixe, à chaque battement, exactement une voix joue) ont également été composés. Ce n'est qu'au siècle dernier, issu du problème analogue de la factorisation des groupes abéliens finis, que des canons rythmiques de pavage apériodique ont été étudiés : ce sont des canons qui pavage un certain intervalle de temps dans lequel chaque voix (rythme intérieure) joue à une séquence apériodique de battements, et la séquence des battements de départ de chaque voix (rythme externe) est également apériodique. Du point de vue musical, l'article séminal était probablement l'article en quatre parties écrit par D.T. Vuza entre 1991 et 1993 ([18, 20, 19, 21]), tandis que la contrepartie mathématique du problème a également été étudiée auparavant, par exemple, par de Bruijn ([8]), Sands ([17]), etc., et après, par ex. par Coven et Meyerowitz ([7]), Jedrzejewski ([12]), Amiot ([1]), Andreatta ([3]), etc.

Une théorie approfondie des conditions d'existence et de la structure des canons rythmiques de pavage apériodique n'a pas encore été établie ; nous essayons d'apporter une contribution à ce domaine fascinant. Dans ce but, la thèse propose un ensemble de théorèmes montrant des méthodes de construction de canons rythmiques apériodiques. Deux définitions sont présentées. La première définit les *canons de Vuza* comme des canons construits à l'aide de Théorème 2, Théorème 3, Théorème 4 et Théorème 5. Ensuite, la seconde définit l'ensemble des *canons de Vuza étendus* comme les canons construits à l'aide de Théorème 6 et Théorème 7, éventuellement combinées de Théorème 2, Théorème 3, Théorème 4 et Théorème 5. La thèse présente également des avancées dans le domaine du calcul en fournissant deux nouveaux algorithmes résultant plus efficaces que ceux connus dans la littérature d'au moins un ordre de grandeur.

2 Canons de pavage apériodiques

Nous fixons quelques notations et donnons les principales définitions.

Définition 1. Si $\mathbb{Z}_n = A \oplus B$, on appelle (A, B) un *canon rythmique de pavage de période n* ; A est appelée la *voix intérieure* et B la *voix extérieure* du canon.

Définition 2. Un rythme $A \subset \mathbb{Z}_n$ est *périodique (de période z)* si et seulement s'il existe un élément $z \in \mathbb{Z}_n$, $z \neq 0$, tel que $z + A = A$. Dans ce cas, A est aussi appelé périodique modulo $z \in \mathbb{Z}_n$. Un rythme $A \subset \mathbb{Z}_n$ est *apériodique* si et seulement s'il n'est pas périodique.

Soit $\Phi_d(x)$ le *polynôme cyclotomique d'indice d* . Ensuite, les canons rythmiques de pavage peuvent être caractérisés comme suit.

Lemme 1. Soit A un rythme dans \mathbb{Z}_n et soit $A(x)$ le polynôme caractéristique de A , c'est-à-dire $A(x) = \sum_{k \in A} x^k$. Étant donné $B \subset \mathbb{Z}_n$ et son polynôme caractéristique $B(x)$, on a que

$$A(x) \cdot B(x) \equiv \sum_{k=0}^{n-1} x^k = \frac{x^n - 1}{x - 1} = \prod_{d \mid n, d \neq 1} \Phi_d(x) \pmod{(x^n - 1)} \quad (1)$$

si et seulement si $A(x)$ et $B(x)$ sont des polynômes à coefficients dans $\{0, 1\}$ et $A \oplus B = \mathbb{Z}_n$.

Par conséquent, pour chaque $d \mid n$, avec $d > 1$, on a

$$\Phi_d(x) \mid A(x) \text{ ou } \Phi_d(x) \mid B(x).$$

Définition 3. Un canon rythmique de pavage (A, B) in \mathbb{Z}_n est un *canon rythmique de pavage apériodique* si A et B sont apériodiques.

On note \mathcal{H} l'ensemble des périodes des groupes de Hajós, c'est-à-dire des groupes qui n'admettent pas de factorisations apériodiques, et \mathcal{V} l'ensemble des périodes des groupes qui admettent de telles factorisations. Le résultat suivant, en conjonction avec Théorème 2, identifie quelles sont les périodes des canons rythmiques de pavage apériodique.

Théorème 1 (Vuza). Soient

1. $\mathcal{V} \doteq \{n \in \mathbb{N} : n = p_1 n_1 p_2 n_2 n_3 \text{ avec } PGCD(p_1 n_1, p_2 n_2) = 1 \text{ et } p_1, n_1, p_2, n_2, n_3 > 1\}$, et
2. $\mathcal{H} \doteq \{p^\alpha, p^\alpha q, p^2 q^2, pqr, p^2 qr, pqr s : \alpha \in \mathbb{N}, p, q, r, s \text{ nombres premiers distincts}\}$,

alors $\mathbb{N}^* = \mathcal{V} \sqcup \mathcal{H}$.

Une méthode de construction exhaustive de canons rythmiques de pavage apériodique n'est pas connue à ce jour; la première méthode pour trouver certains d'entre eux a été fournie par le résultat suivant (voir [11] par Hajós, Théorème 1 dans [8] par de Bruijn, et Proposition 2.2 dans [18] par Vuza).

Théorème 2. Soit $n = p_1 n_1 p_2 n_2 n_3 \in \mathbb{N}$ tel que

1. $p_1, n_1, p_2, n_2, n_3 > 1$ et
2. $PGCD(p_1 n_1, p_2 n_2) = 1$.

Alors \mathbb{Z}_n admet un canon rythmique de pavage apériodique.

Exemple 1. Dans les hypothèses de Théorème 2, un exemple de canon de pavage de \mathbb{Z}_n avec deux sous-ensembles apériodiques est donné par la construction suivante de F. Jedrzejewski (voir Théorème 227 dans [12]). En désignant par \mathbb{I}_k l'ensemble $\{0, 1, \dots, k-1\}$, appelons :

$$\begin{aligned} A_1 &= n_3 p_1 n_1 \mathbb{I}_{n_2} & A_2 &= n_3 p_2 n_2 \mathbb{I}_{n_1} \\ U_1 &= n_3 p_1 n_1 n_2 \mathbb{I}_{p_2} & U_2 &= n_3 p_2 n_2 n_1 \mathbb{I}_{p_1} \\ V_1 &= n_3 n_2 \mathbb{I}_{p_2} & V_2 &= n_3 n_1 \mathbb{I}_{p_1} \\ K_1 &= \{0\} & K_2 &= \{1, 2, \dots, n_3 - 1\}. \end{aligned}$$

Puis prenant

$$\begin{aligned} A &= A_1 \oplus A_2 \\ B &= (U_1 \oplus V_2 \oplus K_1) \sqcup (U_2 \oplus V_1 \oplus K_2), \end{aligned}$$

nous avons le canon $\mathbb{Z}_n = A \oplus B$.

Remarque 1. Désormais, étant donné p_1, n_1, p_2, n_2 , et n_3 , on notera A_1, A_2, U_1, U_2, V_1 , et V_2 les ensembles ainsi appelés dans Exemple 1.

De nombreuses autres façons de construire des canons de pavage apériodiques sont possibles, voir par exemple de Bruijn ([8]), Vuza ([18]), Fidanza ([9]) et Jedrzejewski ([12]). Ces méthodes entrent dans une catégorie traitée par F. Jedrzejewski (Théorème 14 in [13]).

3 Canons de Vuza étendus

Nous donnons maintenant un premier résultat qui affine celui de Jedrzejewski, en levant l'hypothèse que p_1 et p_2 sont premiers et en prouvant que B est apériodique si n_3 satisfait une contrainte arithmétique simple (voir [15]).

Théorème 3. *Soit $n = p_1 n_1 p_2 n_2 n_3 \in \mathbb{N}$ tel que :*

1. $p_1, n_1, p_2, n_2, n_3 > 1$;
2. $\text{PGCD}(p_1 n_1, p_2 n_2) = 1$;
3. *si n_3 n'est pas premier, il n'y a pas de premier q tel que $q \mid n_3$, mais $q \nmid p_1 n_1 p_2 n_2$.*

Soit H le sous-groupe $H = n_3 \mathbb{I}_{p_1 n_1 p_2 n_2}$ de \mathbb{Z}_n et soit K un ensemble complet de cosets représentatifs de \mathbb{Z}_n modulo H tel que K est l'union disjointe $K = K_1 \sqcup K_2$. Alors le couple (A, B) défini par

$$\begin{aligned} A &= A_1 \oplus A_2 \\ B &= (U_1 \oplus V_2 \oplus K_1) \sqcup (U_2 \oplus V_1 \oplus K_2) \end{aligned}$$

est un canon rythmique de pavage apériodique de \mathbb{Z}_n .

Dans une généralisation de Théorème 3, le rythme B est l'union disjointe de trois ensembles, l'un étant périodique à la fois modulo n/p_1 et modulo n/p_2 .

Théorème 4. *Soit $n = p_1 n_1 p_2 n_2 n_3 \in \mathbb{N}$ tel que :*

1. $p_1, n_1, p_2, n_2, n_3 > 1$;
2. $\text{PGCD}(p_1 n_1, p_2 n_2) = 1$;
3. *si n_3 n'est pas premier, il n'y a pas de premier q tel que $q \mid n_3$, mais $q \nmid p_1 n_1 p_2 n_2$.*

Soit H le sous-groupe $H = n_3 \mathbb{I}_{p_1 n_1 p_2 n_2}$ de \mathbb{Z}_n , K un ensemble complet de cosets représentatifs de \mathbb{Z}_n modulo H tel que K est l'union disjointe $K = K_1 \sqcup K_2 \sqcup K_3$ avec $K_1, K_2 \neq \emptyset$, et $W = n_3 n_1 n_2 \mathbb{I}_{p_1 p_2}$. Alors le couple (A, B) défini par

$$\begin{aligned} A &= A_1 \oplus A_2 \\ B &= (U_1 \oplus V_2 \oplus K_1) \sqcup (U_2 \oplus V_1 \oplus K_2) \sqcup (W \oplus K_3) \end{aligned}$$

est un canon rythmique de pavage apériodique de \mathbb{Z}_n .

La deuxième généralisation de Théorème 3 élargit les définitions des ensembles A_1, A_2, V_1 et V_2 .

Théorème 5. Soit $n = p_1 n_1 p_2 n_2 n_3 \in \mathbb{N}$ tel que :

1. $p_1, n_1, p_2, n_2, n_3 > 1$;
2. $\text{PGCD}(p_1 n_1, p_2 n_2) = 1$;
3. si n_3 n'est pas premier, il n'y a pas de premier q tel que $q \mid n_3$, mais $q \nmid p_1 n_1 p_2 n_2$.

Soit H le sous-groupe $H = n_3 \mathbb{I}_{p_1 n_1 p_2 n_2}$ de \mathbb{Z}_n , et $K = K_1 \sqcup K_2$ (avec $K_1, K_2 \neq \emptyset$) un ensemble complet de cosets représentatifs pour \mathbb{Z}_n modulo H . Prendre

- \tilde{A}_1 comme un ensemble apériodique complet de représentants de cosets pour $\mathbb{Z}_{p_2 n_2}$ modulo $n_2 \mathbb{I}_{p_2}$;
- \tilde{A}_2 comme un ensemble apériodique complet de représentants de cosets pour $\mathbb{Z}_{p_1 n_1}$ modulo $n_1 \mathbb{I}_{p_1}$;
- $\tilde{V}_1^1, \dots, \tilde{V}_1^j$ comme ensembles apériodiques complets de représentants de cosets pour $\mathbb{Z}_{p_2 n_1}$ modulo $p_2 \mathbb{I}_{n_1}$;
- $\tilde{V}_2^1, \dots, \tilde{V}_2^h$ comme complet les ensembles apériodiques de représentants de cosets pour $\mathbb{Z}_{p_1 n_2}$ modulo $p_1 \mathbb{I}_{n_2}$.

Définissez $K_1 = K_1^1 \sqcup \dots \sqcup K_1^j$ et $K_2 = K_2^1 \sqcup \dots \sqcup K_2^h$, où $K_\alpha^s = \{k_\alpha^{j_{s-1}+1}, \dots, k_\alpha^{j_s}\}$ sont des sous-ensembles non vides de K_α pour $\alpha = 1, 2$. Alors le couple (A, B) défini par

$$\begin{aligned} A &= n_3 p_1 n_1 \tilde{A}_1 \oplus n_3 p_2 n_2 \tilde{A}_2 \\ B &= \left(\left(U_1 \oplus n_3 n_1 \tilde{V}_2^1 \oplus \{k_1^1, \dots, k_1^{l_1}\} \right) \sqcup \dots \right. \\ &\quad \left. \dots \sqcup \left(U_1 \oplus n_3 n_1 \tilde{V}_2^j \oplus \{k_1^{l_{j-1}+1}, \dots, k_1^{|K_1|}\} \right) \right) \sqcup \\ &\quad \sqcup \left(\left(U_2 \oplus n_3 n_2 \tilde{V}_1^1 \oplus \{k_2^1, \dots, k_2^{m_1}\} \right) \sqcup \dots \right. \\ &\quad \left. \dots \sqcup \left(U_2 \oplus n_3 n_2 \tilde{V}_1^h \oplus \{k_2^{m_{h-1}+1}, \dots, k_2^{|K_2|}\} \right) \right) \end{aligned}$$

est un canon rythmique de pavage apériodique de \mathbb{Z}_n .

Définition 4 (canon de Vuza). On appelle *canons de Vuza* tous les canons obtenus à l'aide des constructions décrites dans Théorème 2, Théorème 3, Théorème 4 et Théorème 5.

Il est possible d'étendre encore plus ce type de constructions. Avec le théorème suivant, on améliore le résultat de Jedrzejewski (Théorème 21 dans [13]).

Théorème 6. Soit $n = p_1 n_1 p_2 n_2 n_3 \in \mathbb{N}$ tel que :

1. $p_1, n_1, p_2, n_2, n_3 > 1$;
2. $\text{PGCD}(p_1 n_1, p_2 n_2) = 1$;
3. il n'y a pas de nombre premier q tel que $q \mid n_3$, mais $q \nmid p_1 n_1 p_2 n_2$.

Soit H le sous-groupe $H = n_3 \mathbb{I}_{p_1 n_1 p_2 n_2}$ de \mathbb{Z}_n . Supposons que L et K soient des sous-ensembles propres de \mathbb{Z}_{n_3} tels que $L \oplus K = \mathbb{Z}_{n_3}$ et $K = K_1 \sqcup K_2$, avec $K_1, K_2 \neq \emptyset$. Alors le couple (A, B) défini par

$$\begin{aligned} A &= A_1 \oplus A_2 \oplus L \\ B &= (U_1 \oplus V_2 \oplus K_1) \sqcup (U_2 \oplus V_1 \oplus K_2) \end{aligned}$$

est un canon rythmique de pavage apériodique de \mathbb{Z}_n .

Définition 5. $R_A \doteq \{d : \Phi_d(x) \mid A(x)\}$ et $S_A \doteq \{p^\alpha \in R_A : p \text{ premier}\}$.

Les conditions de Coven-Meyerowitz sont les suivantes :

(T1) $|A| = \prod_{p^\alpha \in S_A} p$;

(T2) pour tout $p^\alpha, q^\beta, r^\gamma, \dots \in S_A$, $p^\alpha q^\beta r^\gamma \dots \in R_A$, où $p^\alpha, q^\beta, r^\gamma, \dots$ sont des puissances de nombres premiers distincts.

Définition 6 (extension). Soit A un sous-ensemble de \mathbb{Z}_n et soit $S_A = \{p^\alpha, q^\beta, \dots, r^\gamma\}$. On appelle *extension de A* tout rythme \bar{A} dont le polynôme caractéristique est

$$\bar{A}(x) = \Phi_{p^\alpha} \left(x^{\frac{n}{p^\alpha k_p}} \right) \Phi_{q^\beta} \left(x^{\frac{n}{q^\beta k_q}} \right) \dots \Phi_{r^\gamma} \left(x^{\frac{n}{r^\gamma k_r}} \right),$$

où k_p, k_q, \dots, k_r sont des diviseurs de n tels que $p \nmid k_p, q \nmid k_q, \dots, r \nmid k_r$.

Notez que par définition clairement $S_A = S_{\bar{A}}$.

Proposition 1. Soit $A \oplus B = \mathbb{Z}_n$ et soit B vérifie la condition (T2). Alors $\bar{A} \oplus B = \mathbb{Z}_n$ aussi.

En combinant Théorème 6 et Proposition 1, nous sommes capables de trouver de nouveaux canons de Vuza où L n'est pas un sous-ensemble de \mathbb{Z}_{n_3} .

Théorème 7. Soit $n = p_1 n_1 p_2 n_2 n_3 \in \mathbb{N}$ tel que :

1. $p_1, n_1, p_2, n_2, n_3 > 1$;
2. $\text{PGCD}(p_1 n_1, p_2 n_2) = 1$;
3. il n'y a pas de nombre premier q tel que $q \mid n_3$, mais $q \nmid p_1 n_1 p_2 n_2$.

Soit H le sous-groupe $H = n_3 \mathbb{I}_{p_1 n_1 p_2 n_2}$ de \mathbb{Z}_n . Supposons que L et K soient des sous-ensembles propres de \mathbb{Z}_{n_3} tels que $L \oplus K = \mathbb{Z}_{n_3}$ et $K = K_1 \sqcup K_2$, avec $K_1, K_2 \neq \emptyset$. Soit \bar{L} une extension de L ; alors le couple (A, B) défini par

$$\begin{aligned} A &= A_1 \oplus A_2 \oplus \bar{L} \\ B &= (U_1 \oplus V_2 \oplus K_1) \sqcup (U_2 \oplus V_1 \oplus K_2) \end{aligned}$$

est un canon rythmique de pavage apériodique de \mathbb{Z}_n .

Définition 7 (canon de Vuza étendu). On appelle *canons de Vuza étendus* tous les canons obtenus à l'aide des constructions de Théorème 6 et Théorème 7, éventuellement combinées avec celles de Théorème 2, Théorème 3, Théorème 4 et Théorème 5.

Exemple 2. Nous montrons maintenant un canon de Vuza étendu de période $n = 240$ ($p_1 = 5, n_1 = 3, p_2 = 2, n_2 = 2, n_3 = 4$). $L = \mathbb{I}_2$, alors $\bar{L} = 15\mathbb{I}_2$. En choisissant $K_1 = \{2\}$ et $K_2 = \{0\}$, on obtient le canon

$$\begin{aligned} A &= A_1 \oplus A_2 \oplus \bar{L} \\ &= 60\mathbb{I}_2 \oplus 16\mathbb{I}_3 \oplus 15\mathbb{I}_2 \\ B &= (U_1 \oplus V_2 \oplus K_1) \sqcup (U_2 \oplus V_1 \oplus K_2) \\ &= (120\mathbb{I}_2 \oplus 12\mathbb{I}_5 \oplus \{2\}) \sqcup (48\mathbb{I}_5 \oplus 8\mathbb{I}_2 \oplus \{0\}). \end{aligned}$$

Il est à noter qu'il ne serait pas possible d'obtenir un tel canon sans appliquer Théorème 7.

FIGURE 1 - $n = 240$. $A = A_1 \oplus A_2 \oplus \bar{L}$.

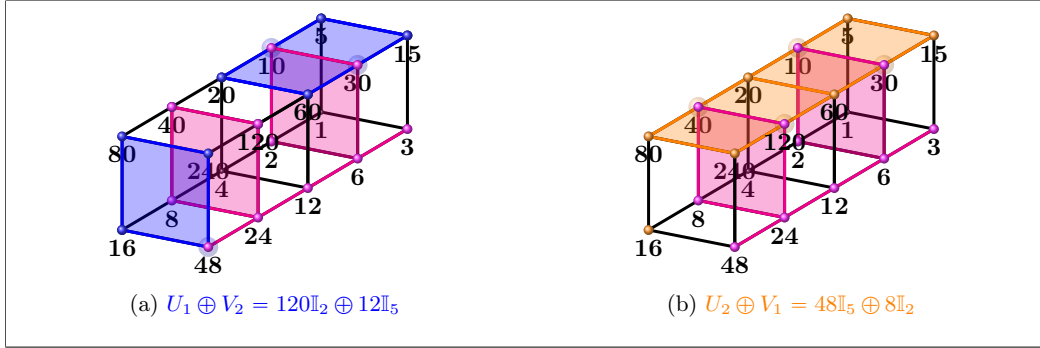

Représentation en treillis d'un canon rythmique de pavage apériodique de période $n = 240$, où $A = 60\mathbb{I}_2 \oplus 16\mathbb{I}_3 \oplus 15\mathbb{I}_2$ et $B = (120\mathbb{I}_2 \oplus 12\mathbb{I}_5 \oplus \{2\}) \sqcup (48\mathbb{I}_5 \oplus 8\mathbb{I}_2 \oplus \{0\})$.

Il est maintenant naturel de se poser la question suivante : combien y a-t-il de canons de Vuza étendus étant donné les cinq paramètres p_1, n_1, p_2, n_2, n_3 et la factorisation $\mathbb{Z}_{n_3} = L \oplus K$?

La première étape consiste à déterminer combien de partitions de \mathbb{Z}_{n_3} permettent de distribuer de manière disjointe les n_3 classes de reste dans les facteurs $(U_1 \oplus n_3 n_1 \tilde{V}_2^j)$, $(U_2 + n_3 n_2 \tilde{V}_1^h)$ et W , en faisant attention d'attribuer au moins une classe aux deux premiers facteurs (sinon le canon deviendrait périodique). D'après Théorème 5, nous devons également considérer tous les différents \tilde{V}_1^j et \tilde{V}_2^h qui fournissent un canon de Vuza (étendu). Nous voulons déterminer dans combien de manières nous pouvons choisir des sous-ensembles apériodiques d'éléments distincts modulo p_1 in $\mathbb{Z}_{p_1 n_2}$ (resp. in $\mathbb{Z}_{p_2 n_1}$) jusqu'à la translation. Par convention, nous fixons le premier élément à 0, et pour chaque autre classe de reste modulo p_1 nous avons n_2 possibilités. Nous devons ignorer les périodiques et finalement nous écartons toutes les translations possibles de $p_1 - 1$. Alors,

$$\#\tilde{V}_1 = \frac{1}{p_2} \sum_{u|p_2} \mu\left(\frac{p_2}{u}\right) \left(n_1^{(u-1)} - 1\right)$$

$$\#\tilde{V}_2 = \frac{1}{p_1} \sum_{v|p_1} \mu\left(\frac{p_1}{v}\right) \left(n_2^{(v-1)} - 1\right).$$

Lorsqu'il n'y a pas de facteur \bar{L} dans le rythme intérieur A , on considère

$$\mathcal{T} = \begin{bmatrix} t_{11} & t_{12} & t_{13} \\ t_{21} & t_{22} & t_{23} \\ \vdots & \vdots & \vdots \\ t_{m1} & t_{m2} & t_{m3} \end{bmatrix}$$

comme la matrice dans laquelle chaque ligne t_i , avec $i = 1, \dots, m$, représente une partition admissible des classes de reste modulo n_3 , et l'entrée unique dans chaque ligne est le nombre de classes de reste modulo n_3 affectées au i -ième facteur

$$U_1 \oplus n_3 n_1 \tilde{V}_2^j, \quad U_2 + n_3 n_2 \tilde{V}_1^h, \quad \text{ou } W.$$

Dans ce cas, le nombre de rythmes externes possibles B est le suivant :

$$\#B = \frac{\#K}{n} \sum_{1 \leq i \leq m} \left(\frac{n}{n_3 \cdot p_1} \cdot \#\tilde{V}_1 \right)^{t_{i1}} \cdot \left(\frac{n}{n_3 \cdot p_2} \cdot \#\tilde{V}_2 \right)^{t_{i2}} \cdot \left(\frac{n}{n_3 \cdot p_1 \cdot p_2} \right)^{t_{i3}} \cdot \binom{n_3}{\mathbf{t}_i}.$$

Exemple 3. Montrons combien de rythmes apériodiques B il existe étant donné $n_1 = 2, n_2 = 3, n_3 = 5, p_1 = 2, p_2 = 3$. Les vecteurs possibles t pour \mathbb{Z}_{n_3} sont 10 :

$$\begin{aligned} \mathcal{T} = \{ & [1, 4, 0], [4, 1, 0], \\ & [2, 3, 0], [3, 2, 0], \\ & [1, 2, 2], [2, 1, 2], [2, 2, 1], \\ & [1, 1, 3], [1, 3, 1], [3, 1, 3] \}. \end{aligned}$$

Le nombre total de rythmes apériodiques possibles B est donné par :

$$\begin{aligned} \#B &= \frac{1}{180} \sum_{1 \leq i \leq 10} \left(\frac{180}{5 \cdot 2} \cdot 1 \right)^{t_{i1}} \left(\frac{180}{5 \cdot 3} \cdot 1 \right)^{t_{i2}} \left(\frac{180}{5 \cdot 2 \cdot 3} \right)^{t_{i3}} \binom{5}{\mathbf{t}_i} \\ &= 45360 + 77760 + 85536 + 72576 \\ &= 281232. \end{aligned}$$

Ce nombre de canons est trois fois supérieur à ce qui était connu dans la littérature et a ensuite été vérifié indépendamment grâce à un algorithme exhaustif (voir Section 4.3).

TABLE 1 – Nombre de rythmes de Vuza étendus pour les valeurs non-Hajós $n \leq 216$.

n	p_1	n_1	p_2	n_2	n_3	L	$\#K$	$\#A$			$\#B$					
								(2)	(6)	(7)	(2)	(3)	(4)	(5)	(6)	
Théorème :								(2)	(6)	(7)	(2)	(3)	(4)	(5)	(6)	
72	2	2	3	3	2	{0}	1	3	0	0	6	0	0	0	0	
108	2	2	3	3	3	{0}	1	3	0	0	180	0	72	0	0	
120	2	2	3	5	2	{0}	1	16	0	0	20	0	0	0	0	
	2	2	5	3	2	{0}	1	8	0	0	18	0	0	0	0	
144	2	2	3	3	4	{0}	1	3	0	0	2808	1944	3888	0	0	
	2	2	3	3	4	{0, 1}	2	0	312	0	0	0	0	0	0	6
	2	2	3	3	4	{0, 9}	2	0	0	12	0	0	0	0	0	6
	2	2	3	3	4	{0, 2}	4	0	156	0	0	0	0	0	0	12
	2	4	3	3	2	{0}	1	6	0	0	12	0	0	48	0	
4	2	3	3	2	{0}	1	6	0	0	6	0	0	0	30	0	
168	2	2	3	7	2	{0}	1	104	0	0	14	0	0	28	0	
	2	2	7	3	2	{0}	1	16	0	0	6	0	0	48	0	
180	2	5	3	3	2	{0}	1	9	0	0	15	0	0	105	0	
	5	2	3	3	2	{0}	1	6	0	0	6	0	0	90	0	
	3	5	2	2	3	{0}	1	16	0	0	500	0	200	1100	0	
	5	3	2	2	3	{0}	1	8	0	0	252	0	72	1728	0	
2	2	3	3	5	{0}	1	3	0	0	45360	77760	158112	0	0		
200	2	2	5	5	2	{0}	1	125	0	0	10	0	0	50	0	
216	2	4	3	3	3	{0}	1	6	0	0	180 + 540	72 + 216	0	12672	0	
	2	2	3	3	6	{0, 3}	8	0	156	0	0	0	0	0	180 + 540 + 72 + 216	
	2	2	3	3	6	{0, 1}	2	0	324	0	0	0	0	0	180 + 72	
	2	2	3	3	6	{0}	1	3	0	0	754272	2449440	5832000	0	0	
	2	2	3	3	6	{0, 1, 2}	3	0	34992	0	0	0	0	0	6	
	2	2	3	3	6	{0, 2, 4}	9	0	10935	0	0	0	0	0	6 + 12	
	2	2	3	9	2	{0}	1	729	0	0	6 + 12	0	0	54	0	
	2	2	9	3	2	{0}	1	27	0	0	6	0	0	162	0	
4	2	3	3	3	{0}	1	6	0	0	252	0	72	5940	0		

Dans chaque colonne, seulement les rythmes qui peuvent être engendrés par le théorème correspondant, mais pas par les précédents sont comptés. Les chiffres gris correspondent aux rythmes qui peuvent être engendrés également par le choix des paramètres de la ligne précédente. Lorsqu'il n'y a pas de colonne (par exemple, $\#A$ pour le théorème 3) tous les rythmes possibles apparaissent déjà dans les colonnes précédentes.

TABLE 2 – Nombre de rythmes de Vuza étendus pour les valeurs non-Hajós $240 \leq n \leq 280$.

n	p_1	n_1	p_2	n_2	n_3	L	$\#K$	#A			#B				
								(2)	(6)	(7)	(2)	(3)	(4)	(5)	(6)
240	2	4	3	5	2	{0}	1	32	0	0	20	0	0	20 + 160	0
	2	2	3	5	4	{0, 6}	4	0	0	588	0	0	0	0	20 + 20
	2	2	3	5	4	{0, 2}	4	0	7252	0	0	0	0	0	20 + 20
	2	2	3	5	4	{0, 15}	2	0	0	64	0	0	0	0	20
	2	2	3	5	4	{0, 3}	2	0	1176	0	0	0	0	0	20
	2	2	3	5	4	{0, 1}	2	0	14504	0	0	0	0	0	20
	2	2	3	5	4	{0}	1	16	0	0	13000	9000	18000	94000	0
	2	2	5	3	4	{0}	1	8	0	0	6264	3240	5184	197856	0
	2	2	5	3	4	{0, 1}	2	0	4016	0	0	0	0	0	18
	2	2	5	3	4	{0, 5}	2	0	0	112	0	0	0	0	18
	2	2	5	3	4	{0, 15}	2	0	0	32	0	0	0	0	18
	2	2	5	3	4	{0, 2}	4	0	2008	0	0	0	0	0	12 + 24
	2	2	5	3	4	{0, 10}	4	0	0	56	0	0	0	0	12 + 24
	2	4	5	3	2	{0}	1	16	0	0	12	0	0	24 + 576	0
4	2	3	5	2	{0}	1	32	0	0	10	0	0	290	0	
4	2	5	3	2	{0}	1	16	0	0	6	0	0	102	0	
252	2	7	3	3	2	{0}	1	27	0	0	21	0	0	315	0
	7	2	3	3	2	{0}	1	9	0	0	6	0	0	618	0
	3	7	2	2	3	{0}	1	104	0	0	980	0	392	5096	0
	7	3	2	2	3	{0}	1	16	0	0	324	0	72	21312	0
	2	2	3	3	7	{0}	1	3	0	0	12830400	71383680	206126208	0	0
264	2	2	3	11	2	{0}	1	5368	0	0	22	0	0	88	0
	2	2	11	3	2	{0}	1	40	0	0	6	0	0	552	0
270	3	3	2	5	3	{0}	1	9	0	0	1125	0	450	48825	0
	3	3	5	2	3	{0}	1	6	0	0	288	0	72	48600	0
280	2	2	5	7	2	{0}	1	2232	0	0	14	0	0	112	0
	2	2	7	5	2	{0}	1	480	0	0	10	0	0	170	0

Dans chaque colonne, seulement les rythmes qui peuvent être engendrés par le théorème correspondant, mais pas par les précédents sont comptés. Les chiffres gris correspondent aux rythmes qui peuvent être engendrés également par le choix des paramètres de la ligne précédente. Lorsqu'il n'y a pas de colonne (par exemple, #A pour le théorème 3) tous les rythmes possibles apparaissent déjà dans les colonnes précédentes.

4 Algorithmes pour énumérer les compléments apériodiques

Nous poursuivons en présentant deux nouveaux algorithmes (qui sont le fruit d'un travail commun avec G. Auricchio, L. Ferrarini, S. Gualandi et L. Pernazza) pour la recherche exhaustive de motifs de pavage (apériodiques), l'un en langage de programmation linéaire entier (le *CS Algorithm*) et l'autre en codage SAT. Nous montrons comment ces modèles peuvent être utilisés pour définir un algorithme itératif qui, étant donné une période n , trouve tous les rythmes qui tuilent avec un rythme donné A . Pour conclure, nous menons plusieurs expériences pour valider l'efficacité temporelle des deux modèles (voir [4]).

Nous définissons deux types de contraintes :

1. les *contraintes de pavage* qui imposent la condition $A \oplus B = \mathbb{Z}_n$, et
2. les *contraintes d'apériodicité* qui imposent que le canon B soit apériodique.

4.1 Contraintes de pavage

Étant donné la période n et le rythme A , soit $\mathbf{a} = [a_0, \dots, a_{n-1}]^\top$ son vecteur caractéristique, c'est-à-dire $a_i = 1$ si et seulement si $i \in A$. En utilisant le vecteur \mathbf{a} nous définissons la matrice circulante $T \in \{0, 1\}^{n \times n}$ du rythme A , c'est-à-dire que chaque colonne de T est le décalage circulaire de la première colonne, qui correspond au vecteur \mathbf{a} . Ainsi, la matrice T est égale à

$$T = \begin{bmatrix} a_0 & a_{n-1} & a_{n-2} & \dots & a_1 \\ a_1 & a_0 & a_{n-1} & \dots & a_2 \\ \vdots & \vdots & \vdots & \ddots & \vdots \\ a_{n-1} & a_{n-2} & a_{n-3} & \dots & a_0 \end{bmatrix}.$$

Nous pouvons utiliser la matrice circulante T pour imposer les conditions de pavage comme suit. Introduisons un littéral x_i pour $i = 0, \dots, n-1$, qui représente le vecteur caractéristique du rythme de pavage B , soit $x_i = 1$ si et seulement si $i \in B$. Ensuite, la condition de pavage peut être écrite avec la contrainte linéaire suivante :

$$\sum_{i \in \{0, \dots, n-1\}} T_{ij} x_i = 1, \quad \forall j = 0, \dots, n-1. \quad (2)$$

Notez que l'ensemble de contraintes linéaires (2) impose qu'exactly une variable (littérale) dans l'ensemble $\{x_{n+i-j \bmod n}\}_{j \in A}$ est égale à 1. Par conséquent, nous encodons cette condition sous la forme d'une contrainte **Exactement-un**, c'est-à-dire qu'exactly un littéral peut prendre la valeur 1. La contrainte **Exactement-un** peut être exprimée comme la conjonction des deux contraintes **Au-moins-un** et **Au-plus-un**, pour lesquelles il existe un codage SAT standard (par exemple, voir [6, 16]). Par conséquent, les contraintes de pavage (2) sont codées avec l'ensemble de clauses suivant dépendant de $i = 0, \dots, n-1$:

$$\bigvee_{j \in A} (x_{n-(j-i) \bmod n}) \bigwedge_{k, l \in A, k \neq l} (\neg x_{n-(k-i) \bmod n} \vee \neg x_{n-(l-i) \bmod n}). \quad (3)$$

4.2 Contraintes d'apériodicité

Au vu de Définition 2, s'il existe un $b \in B$ tel que $(d+b) \bmod n \neq b$, alors le canon B n'est pas périodique modulo d .

On formule les contraintes d'apériodicité en introduisant des variables auxiliaires $y_{d,i}$, $z_{d,i}$, $u_{d,i} \in \{0, 1\}$ pour tout diviseur premier $d \in \mathcal{D}_n$ et pour tout entier $i = 0, \dots, d-1$. On pose

$$u_{d,i} = 1 \Leftrightarrow \left(\sum_{k=0}^{n/d-1} x_{i+kd} = \frac{n}{d} \right) \vee \left(\sum_{k=0}^{n/d-1} x_{i+kd} = 0 \right), \quad (4)$$

pour tout $d \in \mathcal{D}_n$, $i = 0, \dots, d-1$, avec la condition

$$\sum_{i=0}^{d-1} u_{d,i} \leq d-1, \quad \forall d \in \mathcal{D}_n. \quad (5)$$

Comme pour [5], les contraintes (4) peuvent être linéarisées à l'aide de techniques de reformulation standard comme suit :

$$0 \leq \sum_{k=0}^{n/d} x_{i+kd} - \frac{n}{d} y_{d,i} \leq \frac{n}{d} - 1 \quad \forall d \in \mathcal{D}_n, \quad i = 0, \dots, d-1, \quad (6)$$

$$0 \leq \sum_{k=0}^{n/d} (1 - x_{i+kd}) - \frac{n}{d} z_{d,i} \leq \frac{n}{d} - 1 \quad \forall d \in \mathcal{D}_n, \quad i = 0, \dots, d-1, \quad (7)$$

$$y_{d,i} + z_{d,i} = u_{d,i} \quad \forall d \in \mathcal{D}_n, \quad i = 0, \dots, d-1. \quad (8)$$

Notez que lorsque $u_{d,i} = 1$ exactement une des deux alternatives incompatibles dans le côté droit de (4) est vraie, alors que chaque fois que $u_{d,i} = 0$ les deux contraintes ne sont pas vérifiées. Corrélativement, la contrainte (8) impose que les variables $y_{d,i}$ et $z_{d,i}$ ne puissent pas être égales à 1 en même temps. D'autre part, la contrainte (5) impose qu'au moins une des variables auxiliaires $u_{d,i}$ soit égale à 0.

Ensuite, nous encodons les conditions précédentes sous la forme d'une formule SAT. Pour coder la clause **Si-et-seulement-si**, nous utilisons l'équivalence logique entre $C_1 \Leftrightarrow C_2$ et $(\neg C_1 \vee C_2) \wedge (C_1 \vee \neg C_2)$. La clause C_1 est donnée directement par le littéral $u_{d,i}$. La clause C_2 , exprimant le côté droit de (4), c'est-à-dire la contrainte que les variables doivent être toutes vraies ou toutes fausses, peut s'écrire

$$C_2 = \left(\bigwedge_{k=0}^{n/d} x_{i+kd} \right) \vee \left(\bigwedge_{k=0}^{n/d} \bar{x}_{i+kd} \right), \quad \forall d \in \mathcal{D}_n.$$

Ensuite, la contrainte linéaire (5) peut être énoncée comme la formule SAT :

$$\neg (u_{d,0} \wedge u_{d,1} \wedge \dots \wedge u_{d,(d-1)}) = \bigvee_{l=0}^{d-1} \bar{u}_{d,l}, \quad \forall d \in \mathcal{D}_n.$$

Enfin, nous exprimons les contraintes d'apériodicité en utilisant

$$\bigwedge_{i=0}^{d-1} [(\neg C_2 \vee u_{d,i}) \wedge (C_2 \vee \bar{u}_{d,i})] \wedge \bigvee_{l=0}^{d-1} \bar{u}_{d,l}, \quad \forall d \in \mathcal{D}_n. \quad (9)$$

Notez que joindre (2), (6)–(8) avec une fonction objectif constante donne un modèle ILP complet, qui peut être résolu avec un solveur ILP moderne tel que Gurobi pour énumérer tous les possibles solutions. En même temps, en joignant (3) et (9) dans une formule CNF unique, nous obtenons notre codage SAT complet du problème des compléments de pavage apériodiques.

TABLE 3 – Compléments de pavage aperiodiques pour les périodes $n \in \{72, 108, 120, 144, 168\}$.

n	p_1	n_1	p_2	n_2	n_3	temps d'exécution (s)				# B
						FOP	CSA	SAT	ILP	
72	2	2	3	3	2	1.59	0.10	< 0.01	0.03	6
108	2	2	3	3	3	896.06	7.84	0.09	0.19	252
120	2	2	5	3	2	24.16	0.27	0.02	0.04	18
	2	2	3	5	2	10.92	0.14	0.01	0.04	20
144	4	2	3	3	2	82.53	2.93	0.02	0.11	36
	2	2	3	3	4	> 10800.00	> 10800.00	11.04	46.96	8640
	2	2	3	3	4	7.13	0.10	< 0.01	0.05	6
	2	4	3	3	2	80.04	0.94	0.02	0.08	60
168	2	2	7	3	2	461.53	17.61	0.04	0.20	54
	2	2	3	7	2	46.11	0.91	0.02	0.07	42

4.3 Résultats de calcul

Tout d'abord, nous comparons les résultats obtenus en utilisant notre modèle ILP et l'encodage SAT avec les temps d'exécution de la *Fill-Out Procédure* (voir [14]) et de le *CS Algorithm* (voir [5]). Nous utilisons les canons de périodes 72, 108, 120, 144 et 168 qui ont été entièrement énumérés par Vuza [18], Friperntinger [10], Amiot [2], Kolountzakis et Matolcsi [14]. Tableau 3 montre clairement que les deux nouvelles approches surpassent l'état de l'art, et en particulier, que SAT fournit la meilleure approche de solution.

Les nouveaux algorithmes ont également été utilisés pour étudier certaines classes de canons de périodes n plus grandes (180, 216, 240, 900) qui étaient auparavant insolubles. En particulier, nous avons terminé l'énumération des canons aperiodiques de période 180. Il s'est avéré que les canons aperiodiques que nous obtenons à la fin de la recherche informatique sont exactement les canons de Vuza étendus de période 180.

Références

- [1] E. Amiot. Why rhythmic Canons are interesting. *E. Lluis-Puebla, G. Mazzola et T. Noll (eds.), Perspectives of Mathematical and Computer-Aided Music Theory, EpOs*, pages 190–209, 2004.
- [2] E. Amiot. New perspectives on rhythmic canons and the spectral conjecture. *Journal of Mathematics and Music*, 3(2) :71–84, 2009.
- [3] M. Andreatta, C. Agon, and E. Amiot. Tiling problems in music composition : Theory and Implementation. *International Computer Music Conference*, pages 156–163, 2002.
- [4] G. Auricchio, L. Ferrarini, S. Gualandi, G. Lanzarotto, and L. Pernazza. A SAT Encoding to Compute Aperiodic Tiling Rhythmic Canons. In *International Conference on Integration of Constraint Programming, Artificial Intelligence, and Operations Research*, pages 14–23. Springer, 2022.
- [5] G. Auricchio, L. Ferrarini, and G. Lanzarotto. An Integer Linear Programming Model for Tilings. *arXiv preprint arXiv : 2107.04108*, 2021.

- [6] O. Bailleux and Y. Boufkhad. Efficient CNF encoding of boolean cardinality constraints. In *International conference on principles and practice of constraint programming*, pages 108–122. Springer, 2003.
- [7] E.M. Coven and A. Meyerowitz. Tiling the integers with translates of one finite set. *Journal of Algebra*, 212(1) :161–174, 1999.
- [8] N.G. de Bruijn. On the factorization of finite abelian groups. *Proceedings of the Koninklijke Nederlandse Akademie van Wetenschappen : Series A : Mathematical Sciences*, 61(3) :258–264, 1953.
- [9] G. Fidanza. Canoni ritmici a mosaico. *Tesi di Laurea, Università degli Studi di Pisa*, 2007.
- [10] H. Fripertinger, L. Reich, et al. *Remarks on rhythmical canons*. Citeseer, 2005.
- [11] G. Hajós. Sur la factorisation des groupes abéliens. *Časopis Pěst. Mat. Fys.*, 74 :157–162, 1950.
- [12] F. Jędrzejewski. *Mathematical theory of music*. Ircam-Centre Pompidou, Parigi, 2006.
- [13] F. Jędrzejewski. Enumeration of Vuza Canons. *arXiv preprint arXiv : 1304.6609*, 2013.
- [14] M.N. Kolountzakis and M. Matolcsi. Algorithms for translational tiling. *Journal of Mathematics and Music*, 3(2) :85–97, 2009.
- [15] G. Lanzarotto and L. Pernazza. Extended Vuza Canons. In *International Conference on Mathematics and Computation in Music*, pages 112–126. Springer, 2022.
- [16] T. Philipp and P. Steinke. Pblib – A library for encoding pseudo-boolean constraints into CNF. In *International Conference on Theory and Applications of Satisfiability Testing*, pages 9–16. Springer, 2015.
- [17] A.D. Sands. On the factorisation of finite abelian groups. III. *Acta Mathematica Academiae Scientiarum Hungarica*, 25(3-4) :279–284, 1974.
- [18] D.T. Vuza. Supplementary sets and regular complementary unending canons (part one). *Perspectives of New Music*, pages 22–49, 1991.
- [19] D.T. Vuza. Supplementary sets and regular complementary unending canons (part three). *Perspectives of New Music*, pages 102–124, 1992.
- [20] D.T. Vuza. Supplementary sets and regular complementary unending canons (part two). *Perspectives of New Music*, pages 184–207, 1992.
- [21] D.T. Vuza. Supplementary sets and regular complementary unending canons (part four). *Perspectives of New Music*, pages 270–305, 1993.

Contents

1	Introduction	1
2	Tiling rhythmic canons	3
2.1	Musical and algebraic definition	3
2.2	The Coven-Meyerowitz Theorem	5
3	Vuza canons	15
3.1	Aperiodic factorisations	15
3.2	Vuza canons	17
3.3	Lattice representations	22
3.4	Extended Vuza canons	26
3.5	Operations on aperiodic canons	44
3.5.1	Duality	44
3.5.2	k -stuttering (and multiplexing) and k -zooming	45
3.5.3	Affine transformation	47
3.5.4	k -concatenation	47
3.5.5	Uplifting	50
3.5.6	Operations on extended Vuza canons	50
4	Algorithms for aperiodic complements	61
4.1	The Coven-Meyerowitz complement	61
4.2	The Fill-Out Procedure	65
4.3	The Cutting Sequential Algorithm	65
4.3.1	Tiling constraints	67
4.3.2	Aperiodicity constraints	68
4.3.3	Computational results	74
4.4	The SAT Encoding Algorithm	76
4.4.1	Tiling constraints	76
4.4.2	Aperiodicity constraints	77
4.4.3	Computational results	78
4.5	Enumerating aperiodic canons	81
4.5.1	The cases $n = 180$ and $n = 200$	81
4.5.2	The case $n = 900$ with $S_A = \{2, 3, 5\}$	84

4.6	Testing necessity of condition (T2)	96
-----	---	----

List of Tables

3.1	All possible \tilde{A}_1 and \tilde{A}_2 for some non-Hajós values of $n \leq 168$	38
3.2	All possible \tilde{A}_1 and \tilde{A}_2 for $n = 180$	39
3.3	All possible \tilde{V}_1 and \tilde{V}_2 for non-Hajós values of $n \leq 180$	40
3.4	Number of extended Vuza rhythms for non-Hajós values of $n \leq 216$	41
3.5	Number of extended Vuza rhythms for non-Hajós values of $240 \leq n \leq 280$. . .	42
4.1	Number of tiling complements of the aperiodic rhythms tested.	74
4.2	Runtimes (in seconds) of the <i>CS Algorithm</i> and the <i>Fill-Out Procedure</i>	76
4.3	Aperiodic tiling complements for periods $n \in \{72, 108, 120, 144, 168\}$	79
4.4	Aperiodic tiling complements for periods $n \in \{180, 420, 900\}$	80
4.5	Number of extended Vuza canons for $n = 900$, with $n_3 \in \{2, 3, 5, 6, 10, 15\}$. . .	94
4.6	Number of extended Vuza canons for $n = 900$, with $n_3 \in \{4, 9, 25\}$	95
4.7	Rhythms with superfluous cyclotomic factors checked.	96

List of Figures

3.1	Graphic representations of tiling rhythmic canons.	22
3.2	$n = 72$. $A_{CM} = 18\mathbb{I}_2 \oplus 8\mathbb{I}_3$	23
3.3	$n = 108$. $A_{CM} = 27\mathbb{I}_2 \oplus 12\mathbb{I}_3$	23
3.4	$n = 120$. $A = 30\mathbb{I}_2 \oplus 8\mathbb{I}_3$	23
3.5	$n = 120$. $A = 30\mathbb{I}_2 \oplus 8\mathbb{I}_5$	24
3.6	$n = 144$. $A_{CM} = 18\mathbb{I}_2 \oplus 16\mathbb{I}_3$	24
3.7	$n = 144$. $A_{CM} = 36\mathbb{I}_2 \oplus 16\mathbb{I}_3$	24
3.8	$n = 144$. $A_1 \oplus A_2 \oplus A_3 = 36\mathbb{I}_2 \oplus 16\mathbb{I}_3 \oplus A_3$	25
3.9	$n = 144$. $A_1 \oplus A_2 \oplus 2A_3 = 36\mathbb{I}_2 \oplus 16\mathbb{I}_3 \oplus 2A_3$	25
3.10	$n = 168$. $A = 42\mathbb{I}_2 \oplus 8\mathbb{I}_3$	25
3.11	$n = 168$. $A = 42\mathbb{I}_2 \oplus 8\mathbb{I}_7$	26
3.12	$n = 216$. $B = (U_1 \oplus V_2 \oplus K_1) \sqcup (U_2 \oplus V_1 \oplus K_2)$	27
3.13	$n = 216$. $B = (U_1 \oplus V_2 \oplus K_1) \sqcup (U_2 \oplus V_1 \oplus K_2) \sqcup (W \oplus K_3)$	29
3.14	$n = 252$. $B = (U_1 \oplus 14\tilde{V}_2 \oplus K_1) \sqcup (U_2 \oplus 6\tilde{V}_1 \oplus K_2)$	32
3.15	$n = 216$. $A = A_1 \oplus A_2 \oplus L$	33
3.16	$n = 240$. $A = A_1 \oplus A_2 \oplus \bar{L}$	35
3.17	$n = 144$. $A = 16\mathbb{I}_3 \oplus 36\mathbb{I}_2 \oplus \mathbb{I}_2$	36
3.18	$n = 144$. $A_{CM} = 9\mathbb{I}_2 \oplus 36\mathbb{I}_2 \oplus 16\mathbb{I}_3$	46
3.19	$n = 144$. Grid representation.	46
3.20	$n = 360$. Grid representation.	48
3.21	$n = 360$. $A_{CM} = 90\mathbb{I}_2 \oplus 40\mathbb{I}_3$	49
3.22	$n = 144$. $A_{CM} = 18\mathbb{I}_2 \oplus 72\mathbb{I}_2 \oplus 16\mathbb{I}_3$	49
3.23	$n = 144$. $A_{CM} = 18\mathbb{I}_2 \oplus 36\mathbb{I}_2 \oplus 16\mathbb{I}_3$	53
3.24	$n = 216$. $A_{CM} = 54\mathbb{I}_2 \oplus 8\mathbb{I}_3 \oplus 24\mathbb{I}_3$	53
3.25	$n = 360$. $A = 18\mathbb{I}_6 \oplus 40\mathbb{I}_2$	54
3.26	$n = 144$. $A_{CM} = 36\mathbb{I}_2 \oplus 16\mathbb{I}_3$	55
3.27	$n = 216$. $A_{CM} = 54\mathbb{I}_2 \oplus 24\mathbb{I}_3$	55
3.28	$n = 360$. $A_{CM} = 90\mathbb{I}_2 \oplus 40\mathbb{I}_3$	56
3.29	$n = 288$. $A_{CM} = 36\mathbb{I}_2 \oplus 32\mathbb{I}_3$	57
3.30	$n = 144$. $A_{CM} = 18\mathbb{I}_2 \oplus 16\mathbb{I}_3$	59
3.31	$n = 216$. $A_{CM} = 54\mathbb{I}_2 \oplus 8\mathbb{I}_3$	59
4.1	$n = 4500$. $A_{CM} = 1125\mathbb{I}_2 \oplus 500\mathbb{I}_3 \oplus 180\mathbb{I}_5$	63

4.2	$n = 4500$. $B_{CM} = 2250\mathbb{I}_2 \oplus 1500\mathbb{I}_3 \oplus 36\mathbb{I}_5 \oplus 900\mathbb{I}_5$	64
4.3	Times (in seconds) to find the next solution with <i>CS Algorithm</i>	75
4.4	$n = 180$	85
4.5	$n = 200$. $A_{CM} = 50\mathbb{I}_2 \oplus 8\mathbb{I}_3$	86
4.6	$n = 900$. $A_1 \oplus A_2 = 45\mathbb{I}_2 \oplus 20\mathbb{I}_3$	90
4.7	$n = 900$. $A_1 \oplus A_2 = 225\mathbb{I}_2 \oplus 36\mathbb{I}_5$	91
4.8	$n = 900$. $A_1 \oplus A_2 = 100\mathbb{I}_3 \oplus 36\mathbb{I}_5$	92
4.9	$n = 900$. $A_{CM} = 225\mathbb{I}_2 \oplus 100\mathbb{I}_3 \oplus 36\mathbb{I}_5$	93
4.10	$n = 1050$. $R_A = \{2, 10, 21, 25, 50, 105\}$	97
4.11	$n = 6300$. $R_A = \{3, 4, 9, 10, 20, 28, 100, 140, 700\}$	98

Chapter 1

Introduction

The link between music and mathematics was discovered in ancient times, a few observations being traditionally attributed to the genius of Pythagoras. He was allegedly the first to guess the existence of numerical relationships between pitches, and to build a musical scale through these. But this relationship was then studied by many scientists, philosophers, musicians such as Ptolemy, Boethius, Zarlino, Galileo Galilei, Gottfried Wilhelm Leibniz, Jean-Philippe Rameau, and Leonhard Euler. At first sight two diametric domains, music and mathematics came out to actually have many things in common. Many connections have been discovered, some of which albeit having nowadays a long tradition, are still offering new problems and ideas to researchers, whether they be music composers or computer scientists. The combined study of the two disciplines can only benefit both parts of the relationship.

The help of mathematics is fundamental in the study and understanding of music, as in 1722 the composer Jean-Philippe Rameau wrote:

Despite all the experience I may have gained in music from being associated with it for so long, I must confess that it was only with the help of mathematics that my ideas became clearer.

It is equally true that at times, in history, music has anticipated mathematical concepts discovered only later.

In this thesis we deal with Tiling Rhythmic Canons, that are purely rhythmic contrapuntal compositions. Canons in music have a very long tradition; a few cases of tiling rhythmic canons (i.e. canons such that, given a fixed tempo, at every beat exactly one voice is playing) have also been composed. Only in the last century, stemming from the analogous problem of factorising finite abelian groups, aperiodic tiling rhythmic canons have been studied: these are canons that tile a certain interval of time in which each voice (inner voice) plays at an aperiodic sequence of beats, and the sequence of starting beats of every voice (outer voice) is also aperiodic. From the musical point of view the seminal paper was probably the four-parts article written by D.T. Vuza between 1991 and 1993 ([29, 31, 30, 32]), while the mathematical counterpart of the problem was studied also before, e.g. by de Bruijn ([10]), Sands ([28]), etc., and after, e.g. by Coven and

Meyerowitz ([9]), Jedrzejewski ([18]), Amiot ([1]), Andreatta ([4]), etc. A thorough theory of the conditions of existence and the structure of aperiodic tiling rhythmic canons has not been established yet; we try to give a contribution to this fascinating field.

In Chapter 2, we present tiling rhythmic canons from a mathematical and algebraic point of view, focusing in particular on their polynomial representation and reporting the fundamental results known in the literature.

In Chapter 3, we deal in particular with aperiodic rhythmic canons, that is canons in which in both rhythms there is no repeated inner structures: neither the inner nor the outer rhythm is obtained as a repetition of a shorter rhythm. From a mathematical point of view, they are the most interesting canons since they constitute a possible approach to solve the *Fuglede conjecture* on spectral domains.

If one of the sets, say A , is given, it is well-known that the problem of finding a *complement* B has in general no unique solution. It is very easy to find tiling canons in which at least one of the sets is *periodic*, i.e. it is built repeating a shorter rhythm.

In Chapter 4 we deal with the design of two algorithms whose purpose is to find the complementary tiling rhythm of a given aperiodic rhythm in a certain period n .

To enumerate all aperiodic tiling canons one has to overcome two main hurdles: on one side, the problem lacks the algebraic structure of other ones, such as those involving ring or group theory; on the other side, the combinatorial size of the domain becomes very soon enormous.

The algorithms are implemented through Integer Linear Programming (ILP) model and SAT Encoding and solve the Aperiodic Tiling Complements Problem presented in Section 4.3 in a faster time than previously known approaches.

Using a modern SAT solver we have been therefore able to compute the complete list of aperiodic tiling complements of some classes of Vuza rhythms for periods $n = \{180, 420, 900\}$, which were up to now computationally unreachable.

Chapter 2

Tiling rhythmic canons

2.1 Musical and algebraic definition

In this section, we introduce the main notions about rhythmic canons in mathematics. We refer to [11] for a complete and exhaustive discussion of these preliminary results.

A *canon* is a polyphonic musical form, born in the fourteenth century, typical of classical music. It is a contrapuntal composition, that is, it is formed by the progressive superposition of several voices, performing the same melodic theme, or variations of it according to precise tonal rules. Popular culture is rich in them: consider for example the Italian popular nursery song “*Fra’ Martino*” (originally “Frère Jacques” or, in English, “Brother John”).

There are two fundamental characteristics:

1. each voice periodically performs the same motif, and
2. these performances are temporally shifted.

In the following we will be interested in the case in which the motif, or *pattern*, is purely rhythmic, and we can therefore imagine it performed by a percussive instrument, disregarding the duration and pitch of the individual notes.

Musically, a rhythmic canon consists in the performance of the same rhythmic motif by different voices, each with a different starting time. In this work we are interested in a particular family of rhythmic canons: those in which the voices do not overlap but, when played simultaneously, give rise to a regular pulsation, that is, in each time beat there is one and only one active voice. These rhythmic canons are called *tiling*.

Since we are considering the pattern from an exclusively rhythmic point of view, and each beat occurs only in the presence of a note, we consider a musical writing without rests, obtained by incorporating each rest in the note that precedes it. We therefore arrive at a first mathematical definition.

Definition 1 (rhythm). A *rhythm* is a subset of a cyclic group $R \subset \mathbb{Z}_n$. The order n of the group is the *period* of the rhythm.

To complete the model of a tiling rhythmic canon it remains to express mathematically the complementarity of the voices, that is the simultaneous occurring of the following facts:

1. voices do not overlap, and
2. the execution of the canon gives rise to a regular pulse.

Let R be the rhythm of the canon and n its period. Since each voice of the canon performs R translated over time, the i -th voice will perform $R + [b_i]_n$. Assuming for the sake of simplicity that the first voice begins its performance at time $b_0 = 0$, we can express mathematically the different entries with the following sets of remainder classes modulo n :

$$\begin{aligned} A_0 &= R \\ A_1 &= R + [b_1]_n \\ &\vdots \\ A_k &= R + [b_k]_n, \end{aligned}$$

and all of these are subsets of \mathbb{Z}_n . The two previous conditions of complementarity are expressed mathematically in the following way:

1. $A_i \cap A_j = \emptyset$ for every $i \neq j$, $i, j = 0, \dots, k$ and
2. $A_0 \cup A_1 \cup \dots \cup A_k = \mathbb{Z}_n$.

Example 1. We observe that not all rhythms can verify these conditions: it is not always possible to find an appropriate set of entries $B = \{b_i\}_{i=1}^k \subset \mathbb{Z}_n$. An example of this is the samba rhythm $S = \{0, 2, 5, 7, 9, 12, 14\} \pmod{16}$, as can be seen directly: let $A_0 = S$ be the first voice. Since the second voice, $A_1 = S + [b_1]_{16}$, must not intersect A_0 , we necessarily have $b_1 = \pm 1$. Given these two voices of 7 elements each, only 2 elements remain in \mathbb{Z}_{16} , insufficient for a third voice.

We are lead to give the following definition.

Definition 2 (direct sum). Let $(G, +)$ be an abelian group, let $A, B \subset G$. Let us define the application

$$\begin{aligned} \sigma : A \times B &\rightarrow G \\ (a, b) &\mapsto a + b \end{aligned}$$

We call $A + B \doteq \text{Im}(\sigma)$. If it is injective we say that A and B are in *direct sum*, or, equivalently, that $\text{Im}\sigma \subset G$ is the *direct sum* of A and B and we write

$$A \oplus B \doteq \text{Im}(\sigma).$$

Given an element $c \in A \oplus B$, the unique $a \in A$ and $b \in B$ such that $c = a + b$ will be the *projections* of c on A and B respectively. If $G = A \oplus B$, we say that G is *factored* as a direct sum of A and B , and we call $G = A \oplus B$ *factorisation* of G .

Clearly, if A and B are in direct sum, then $\sigma : A \times B \rightarrow A \oplus B$ is bijective, so $|A \oplus B| = |A||B|$.

We conventionally denote the elements of the cyclic group \mathbb{Z}_n with the integers $\{0, 1, \dots, n-1\}$, i.e. with the least non-negative representatives of the remainder classes modulo n : $\{[0]_n, [1]_n, \dots, [n-1]_n\}$.

The direct sum of sets, a priori, has no algebraic structure; however, if subsets A and B are also subgroups of G , the direct sum of A and B thought as sets (see Definition 2) coincides with the usual direct sum between subgroups. We can therefore speak of direct sum without risk of ambiguity. We now have all the tools necessary to define a tiling rhythmic canon.

Definition 3 (tiling rhythmic canon). We have a *tiling rhythmic canon* of period n with motif (or *inner rhythm*) A and set of entries (or *outer rhythm*) B when A, B are subsets of \mathbb{Z}_n and $A \oplus B = \mathbb{Z}_n$.

We can now already give a necessary condition for a rhythm to be an inner rhythm of a tiling canon: if $A \oplus B$ is a factorisation of \mathbb{Z}_n , then $|A||B| = n$.

We observe that the commutativity of the addition in the cyclic group \mathbb{Z}_n makes the definition of rhythmic canon symmetrical in the inner and outer rhythms. What is the inner rhythm and what the outer rhythm depends solely on the order of writing, and in fact it is defined as:

Definition 4 (dual canon). Given a tiling canon $\mathbb{Z}_n = A \oplus B$, the canon $\mathbb{Z} = B \oplus A$ is called *dual canon*, or obtained from it by duality.

2.2 The Coven-Meyerowitz Theorem

The inner rhythm of a canon is traditionally represented by the tile of its least non-negative representatives, as we have seen in Section 2.1. We have also assumed that each tile contains at least the element 0. Given these two assumptions, we can naturally transit from a set representation to a polynomial representation using the following definition.

Definition 5 (characteristic polynomial). The *characteristic polynomial* of $A \subset \mathbb{Z}_n$ is

$$A(x) = \sum_{a \in A} x^a.$$

Definition 5 provides a one-to-one correspondence between the subsets of \mathbb{Z}_n and the set of polynomials with coefficients 0 or 1:

$$\begin{aligned} \{A \subset \mathbb{Z}_n\} &\leftrightarrow \{0, 1\}[x] \\ A &\mapsto A(x) \\ \{a_i : a_i = 1\}_{i=0}^{n-1} &\leftrightarrow \sum_{i=0}^{n-1} a_i x^i. \end{aligned}$$

Then the rhythms of a canon can be represented by the respective characteristic polynomials.

For a rhythmic pattern to tile, E. Coven and A. Meyerowitz (see [9]) discovered two conditions that are sufficient, and in certain circumstances even necessary. We discuss their findings in full in this section utilizing the polynomial representation of rhythmic canons.

Definition 6 (R_A, S_A). Let $A \subset \mathbb{Z}_n$ and Φ_d the d -th cyclotomic polynomial. We define:

1. $R_A \doteq \{d \in \mathbb{N}^* : \Phi_d(x) \mid A(x)\}$ and
2. $S_A \doteq \{d \in R_A : d = p^\alpha, p \text{ prime}, \alpha \in \mathbb{N}^*\}$.

Since cyclotomic polynomials will play a fundamental role in this discussion, let us recall the main properties which will be used in the sequel without mention.

Proposition 1. Let p be a prime and $n = p_1^{\alpha_1} p_2^{\alpha_2} \cdots p_n^{\alpha_n}$, with p_i prime $\forall i = 1, \dots, n$, then:

1. $\Phi_p(x) = 1 + x + x^2 + \cdots + x^{p-1}$;
2. $\Phi_n(x) = \Phi_{p_1 \cdots p_n}(x^{p_1^{\alpha_1-1} \cdots p_n^{\alpha_n-1}})$;
3. if $n > 1$ is odd, then $\Phi_{2n}(x) = \Phi_n(-x)$;

$$4. \Phi_n(x^p) = \begin{cases} \Phi_{pn}(x) & \iff p \mid n \\ \Phi_n(x)\Phi_{pn}(x) & \iff p \nmid n; \end{cases}$$

$$5. \Phi_n(1) = \begin{cases} 0 & \iff n = 1 \\ p & \iff n = p^\alpha \\ 1 & \text{otherwise;} \end{cases}$$

6. let m be a positive integer and let $k \doteq \max\{d \mid m : (d, n) = 1\}$, then, taking $m = hk$, we have:

$$\Phi_n(x^m) = \prod_{d \mid m, h \mid d} \Phi_{dn}(x).$$

In particular, if $(m, n) = 1$ we have: $\Phi_n(x^m) = \prod_{d \mid m} \Phi_{dn}(x)$.

Actually, Definition 6 can be given also for $A \subset \mathbb{Z}$; let us simplify the exposition of Coven and Meyerowitz slightly, since for any other polynomial congruent with $A(x) \pmod{(x^n - 1)}$, the subset of the divisors of n in R_A , which are the indices of the relative cyclotomic factors, does not change and S_A is always composed of divisors of n .

Example 2. For example with $A = \{0, 25, 28, 35, 40, 55, 65, 68, 80, 95, 108, 120, 125, 135, 148, 155, 160, 165, 188, 195\}$ we obtain $R_A = \{2, 8, 25, 50, 200\}$ and $S_A = \{2, 8, 25\}$. The presence of all the Φ_d , with $d \mid n$, in $A(x)B(x)$ implies that

- $S_A \cup S_B$ is the set of all prime powers dividing n , and
- $R_A \cup R_B$ is the set of all divisors of n (excluding 1).

We can now state the Coven-Meyerowitz theorem.

Theorem 1 (Coven, Meyerowitz). *Let us consider the following conditions on A (and on its characteristic polynomial $A(x)$).*

$$(T1): A(1) = \prod_{p^\alpha \in S_A} p.$$

$$(T2): \text{If } p_1^{\alpha_1}, \dots, p_m^{\alpha_m} \in S_A \text{ are powers of distinct primes, then } p_1^{\alpha_1} \cdots p_m^{\alpha_m} \in R_A.$$

Then,

1. if A satisfies (T1) and (T2), then A tiles;
2. if A tiles, then A satisfies (T1);
3. if A tiles and $|A|$ has at most two prime factors, then A satisfies (T2).

Remark 1. In their paper [9] Coven and Meyerowitz give condition (T1) in the following form:

$$A(1) = \prod_{p^\alpha \in S_A} \Phi_{p^\alpha}(1).$$

If p is prime, by Proposition 1 $\Phi_{p^\alpha}(1) = p \forall \alpha \geq 1$, therefore the two forms are equivalent.

We now introduce some lemmas, as presented in [9] and proved in detail in [11], which we will use in the proof of Theorem 1, but also to prove some results in Chapter 3: the polynomial approach, in fact, provides a few new important properties.

Lemma 1. *Let $A(x), B(x) \in \mathbb{N}[x]$ and $n \in \mathbb{N}^*$. Then*

$$A(x)B(x) \equiv \sum_{k=0}^{n-1} x^k \pmod{(x^n - 1)} \quad (T0)$$

if and only if

1. $A(x), B(x) \in \{0, 1\}[x]$, so they are the characteristic polynomials of rhythms, resp., A and B , and
2. $A \oplus B = \{r_1, \dots, r_n\} \subset \mathbb{Z}$, with $r_i \not\equiv r_j \pmod{n}$ for all $i, j \in \{1, \dots, n\}$ with $i \neq j$.

Proof.

\implies : Let A and B be the sets of exponents that appear, respectively, in $A(x)$ and $B(x)$, then

$$A(x)B(x) = \sum_{a \in A} n_a x^a \sum_{b \in B} n_b x^b = \sum_{k \in A+B} n_k x^k$$

where $n_k = \sum_{a+b=k} n_a n_b$. For every $k \in A + B$ we consider $\bar{k} \in \{0, \dots, n-1\}$ such that $k \equiv \bar{k} \pmod{n}$, then, reducing $A(x)B(x)$ modulo $x^n - 1$, we have:

$$\sum_{k \in A+B} n_k x^{\bar{k}} = 1 + x + x^2 + \dots + x^{n-1},$$

therefore, necessarily,

- (a) $n_k = 1$ for each $k \in A + B$,
- (b) $n = |\overline{A+B}| = |A + B|$.

Therefore

1. by (a), $A(x)$ and $B(x)$ are polynomials with coefficients in $\{0, 1\}$ and the sets A and B are in direct sum, and
2. by (b), $A \oplus B$ is a complete set of representatives modulo n .

\Leftarrow : We have

$$(A \oplus B)(x) = A(x)B(x) = \{r_1, \dots, r_n\}(x) = x^{r_1} + x^{r_2} + \dots + x^{r_n}.$$

The classes $[r_1]_n, \dots, [r_n]_n$ are all distinct, therefore there exist $k_0, \dots, k_{n-1} \in \mathbb{Z}$ such that:

$$\begin{aligned} 0 &= r_{i_0} - k_0 n \\ 1 &= r_{i_1} - k_1 n \\ &\vdots \\ n-1 &= r_{i_{n-1}} - k_{n-1} n \end{aligned}$$

and therefore

$$A(x)B(x) = x^{k_0 n} + x^{1+k_1 n} + \dots + x^{n-1+k_{n-1} n} \equiv \sum_{k=0}^{n-1} x^k \pmod{(x^n - 1)}.$$

□

Lemma 2. *Let $n \in \mathbb{N}^*$ and let $A(x)$ and $B(x)$ be the characteristic polynomials of rhythms, resp., A and B . The following statements are equivalent:*

1. $A(x)B(x) \equiv \sum_{k=0}^{n-1} x^k \pmod{(x^n - 1)}$;
2. (a) $n = A(1)B(1)$ and
(b) for every $t \mid n$, with $t > 1$, we have that $\Phi_t(x) \mid A(x)B(x)$.

Proof.

1 \implies 2: Condition 1 implies that there exists a polynomial $q(x) \in \mathbb{Z}[x]$ such that

$$A(x)B(x) = \sum_{k=0}^{n-1} x^k + q(x)(x^n - 1).$$

Then

(a) $A(1)B(1) = n$ and

(b) since $x^n - 1 = (x - 1) \sum_{k=0}^{n-1} x^k = \Phi_1(x) \prod_{\substack{t|n \\ t>1}} \Phi_t(x)$, we have that

$$A(x)B(x) = (1 + q(x)(x - 1)) \sum_{k=0}^{n-1} x^k,$$

and therefore, for every $t \mid n$ such that $t > 1$, we have that $\Phi_t(x) \mid A(x)B(x)$.

2 \implies 1: Condition 2 implies that $A(x)B(x) = q(x) \sum_{k=0}^{n-1} x^k$. Moreover, $A(1)B(1) = n$, so $q(1) = 1$. Then, setting $q(x) = \sum_{i=0}^m \alpha_i x^i$, we have that

$$\begin{aligned} A(x)B(x) &= \left(\sum_{i=0}^m \alpha_i x^i \right) \left(\sum_{k=0}^{n-1} x^k \right) \\ &\equiv \left(\sum_{i=0}^m \alpha_i \right) \left(\sum_{k=0}^{n-1} x^k \right) \pmod{(x^n - 1)} \\ &= q(1) \sum_{k=0}^{n-1} x^k \pmod{(x^n - 1)} \\ &= \sum_{k=0}^{n-1} x^k \pmod{(x^n - 1)}, \end{aligned}$$

since $x^i \sum_{k=0}^{n-1} x^k \equiv \sum_{k=0}^{n-1} x^k \pmod{(x^n - 1)}$.

□

Remark 2. By Lemma 1, $A \oplus B = \mathbb{Z}_n$ if and only if

$$A(x)B(x) \equiv \sum_{k=0}^{n-1} x^k \pmod{(x^n - 1)}.$$

Moreover, we infer that, for any $t \mid n$, with $t > 1$,

$$\Phi_t(x) \mid A(x) \text{ or } \Phi_t(x) \mid B(x)$$

using Lemma 2 and the fact that the cyclotomic polynomials are irreducible in $\mathbb{Z}[x]$.

Now we can prove part 1 of Theorem 1.

Proof of Theorem 1 1. : Let us define a polynomial $B(x)$ as

$$B(x) \doteq \prod_{q^\beta \in S} \Phi_{q^\beta} \left(x^{t(q^\beta)} \right),$$

where $S \doteq \{q^\beta : q^\beta \mid \text{lcm}(S_A)\} \setminus S_A$ and $t(q^\beta) \doteq \max\{d : d \mid \text{lcm}(S_A) \text{ and } \gcd(d, q^\beta) = 1\}$. By Proposition 1, we have that

$$\Phi_{q^\beta} \left(x^{t(q^\beta)} \right) = \Phi_q \left(x^{t(q^\beta)q^{\beta-1}} \right) \in \{0, 1\}[x].$$

Hence $B(x) \in \mathbb{N}[x]$.

Let $s \in \mathbb{N}^* \setminus \{1\}$ satisfy $s \mid A(1)B(1)$ and consider its prime factorisation $s = p_1^{\alpha_1} \cdots p_k^{\alpha_k}$. We have 2 possibilities:

1. $p_i^{\alpha_i} \in S_A \forall i = 1, \dots, k$; by (T2), $\Phi_s(x) \mid A(x)$;
2. $p_i^{\alpha_i} \notin S_A$ for some $i = 1, \dots, k$; $\Phi_{p_i^{\alpha_i}} \left(x^{t(p_i^{\alpha_i})} \right) \mid B(x)$, $s/p_i^{\alpha_i}$ is a factor of $t(p_i^{\alpha_i})$, and, by Proposition 1, $\Phi_s(x) \mid \Phi_{p_i^{\alpha_i}} \left(x^{t(p_i^{\alpha_i})} \right)$.

Then, by Lemma 2, condition (T0) of Lemma 1 holds, that is

$$A(x)B(x) \equiv \sum_{k=0}^{n-1} x^k \pmod{(x^n - 1)};$$

therefore $B(x)$ is the polynomial associated with the set B of its exponents, and $A \oplus B$ is a complete set of representatives modulo $A(1)B(1)$; in particular, A tiles. \square

Part (2) of Theorem 1 follows from the following lemma.

Lemma 3. *Let $A(x), B(x) \in \{0, 1\}[x]$, $n \doteq A(1)B(1)$, and $S = \{r^\gamma : r^\gamma \mid n\}$. If $\forall t \in \mathbb{N}^* \setminus \{1\}$ such that $t \mid n$ we have that $\Phi_t(x) \mid A(x)B(x)$, then*

1. $A(1) = \prod_{p^\alpha \in S_A} \Phi_{p^\alpha}(1)$ and $B(1) = \prod_{q^\beta \in S_B} \Phi_{q^\beta}(1)$;
2. $S = S_A \sqcup S_B$.

Proof. Since for every $t \mid n$, with $t > 1$, we have that $\Phi_t(x) \mid A(x)B(x)$, then $S \subset S_A \cup S_B$. Clearly $A(1) \geq \prod_{p^\alpha \in S_A} \Phi_{p^\alpha}(1)$ and $B(1) \geq \prod_{q^\beta \in S_B} \Phi_{q^\beta}(1)$. Thus

$$n = A(1)B(1) \geq \prod_{p^\alpha \in S_A} \Phi_{p^\alpha}(1) \prod_{q^\beta \in S_B} \Phi_{q^\beta}(1) \geq \prod_{r^\gamma \in S} \Phi_{r^\gamma}(1) = n.$$

The last equality follows from Proposition 1. Hence,

1. $A(1)B(1) = \prod_{p^\alpha \in S_A} \Phi_{p^\alpha}(1) \prod_{q^\beta \in S_B} \Phi_{q^\beta}(1)$, which implies that

$$A(1) = \prod_{p^\alpha \in S_A} \Phi_{p^\alpha}(1) \quad \text{and} \quad B(1) = \prod_{q^\beta \in S_B} \Phi_{q^\beta}(1);$$

2. $\prod_{p^\alpha \in S_A} \Phi_{p^\alpha}(1) \prod_{q^\beta \in S_B} \Phi_{q^\beta}(1) = \prod_{r^\gamma \in S} \Phi_{r^\gamma}(1)$ and therefore $S_A \cup S_B \subset S$ and $S_A \cap S_B = \emptyset$.

□

We can now complete the

Proof of Theorem 1.2. Since A tiles, by Lemma 1, there exists $B \subset \mathbb{Z}_n$ such that A and B verify condition (T0) in Lemma 1; therefore, by Remark 2, $A(x)$ and $B(x)$ verify the hypotheses of Lemma 3. In particular A verifies (T1) condition. □

Example 3. We observe that the converse of Theorem 1.2 does not hold, that is, condition (T1) is not sufficient for A to tile. For example, let us consider the rhythm

$$A = \{0, 1, 3, 4, 6, 7\}.$$

A clearly does not tile and its characteristic polynomial is

$$A(x) = 1 + x + x^3 + x^4 + x^6 + x^7 = (1 + x)(1 + x^3 + x^6) = \Phi_2(x)\Phi_9(x).$$

$S_A = \{2, 3^2\}$, then A verifies condition (T1):

$$A(1) = 6 = 2 \cdot 3 = \prod_{p \in S_A} p.$$

For the proof of the third part of the Coven-Meyerowitz theorem, see [9].

The tiling property is invariant under affine transformations.

Lemma 4. *Let $A \subset \mathbb{N}$ be finite. For every $t \in \mathbb{Z}$ and $k \in \mathbb{N}$ we have:*

$$A \text{ tiles} \iff kA + t \text{ tiles.}$$

Proof. Because of the translation invariance of the tiling property, it is sufficient to show that

$$A \text{ tiles} \iff kA \text{ tiles.}$$

\implies Since A tiles, there exists $C \subset \mathbb{Z}$ such that $A \oplus C = \mathbb{Z}$ is a tiling. We therefore have $kA \oplus kC = k\mathbb{Z}$, and consequently the tiling

$$\mathbb{Z} = \{0, \dots, k-1\} \oplus k\mathbb{Z} = \{0, \dots, k-1\} \oplus kA \oplus kC = kA \oplus (\{0, \dots, k-1\} \oplus kC).$$

\impliedby Since kA tiles, there exists $C \subset \mathbb{Z}$ such that $kA \oplus C = \mathbb{Z}$. Setting $C_0 \doteq \{c \in C : c \equiv 0 \pmod{k}\}$; we have that

$$kA \oplus C_0 = k\mathbb{Z}.$$

\subseteq It is clear;

\supseteq For every $kz \in k\mathbb{Z} \subset \mathbb{Z}$, $kz = ka + c$, consequently $c \in C_0$.

Then $A \oplus C_0/k = \mathbb{Z}$ is a tiling.

□

The next two lemmas establish that also conditions (T1) and (T2) are invariant with respect to affine transformations.

Lemma 5. *Let $A \subset \mathbb{N}$ be finite and $n \in \mathbb{N}$, let us set $A' \doteq A + n$. We have that:*

1. $A(x)$ satisfies (T1) if and only if $A'(x)$ satisfies (T1),
2. $A(x)$ satisfies (T2) if and only if $A'(x)$ satisfies (T2).

Proof. It suffices to observe that $|A| = |A'|$ and $A'(x) = x^n A(x)$, therefore for every cyclotomic polynomial $\Phi_d(x)$ we have that $\Phi_d(x) \mid A(x) \iff \Phi_d(x) \mid A'(x)$. □

Lemma 6. *Let $A \subset \mathbb{N}$ and $k \in \mathbb{N}$. Let us set $\hat{A} \doteq kA$, we have:*

1. A satisfies (T1) $\iff \hat{A}$ satisfies (T1),
2. A satisfies (T2) $\iff \hat{A}$ satisfies (T2).

Proof. Let us start with one remark. Let $k = p$ prime, then we are going to prove that

$$S_{\hat{A}} = \{p^{\alpha+1} : p^\alpha \in S_A\} \cup \{q^\beta \in S_A : q \text{ prime} \neq p\}.$$

$\hat{A}(x) = A(x^k)$, therefore:

$$R_{\hat{A}} = pR_A \cup \{n \in R_A : p \nmid n\}.$$

In particular $S_{\hat{A}} = \{r^\gamma \in R_{\hat{A}} : r \text{ prime}\}$ and

1. $r^\gamma \in pR_A \iff r = p$ and $r^{\gamma-1} \in R_A$
2. $r^\gamma \in \{n \in R_A : p \nmid n\} \iff r \neq p$ and $r^\gamma \in R_A$ hence the thesis.

Using the previous remark we prove separately the two statements of our theorem.

1. We divide the proof of this first statement into cases:
 - (a) If $k = p$ prime, the thesis follows from the remark.
 - (b) If $k = p^\alpha$, by iterating the remark we have that

$$S_{\hat{A}} = \{p^{\alpha+\gamma} : p^\alpha \in S_A\} \cup \{q^\beta \in S_A : q \text{ prime} \neq p\},$$

and the thesis follows, as in the previous case.

(c) Let $k = p_1^{\alpha_1} p_n^{\alpha_n}$ we prove that

$$S_{\hat{A}} = \bigcup_{i=1}^n \{p_i^{\alpha+\gamma_i} : p^\alpha \in S_A\} \cup \{q^\beta \in S_A : q \text{ prime} \neq p_i \forall i\}.$$

In fact just consider

$$S_A = \bigcup_{i=1}^n \{p_i^{\gamma_i} \in S_{A_i}\} \cup \{q^\beta \in S_A : q \text{ prime} \neq p_i \forall i\}.$$

and iterate the previous remark, since at each step the multiplication by the first p_i modifies the set obtained in the previous step only the exponent of p_i , increasing it by 1. Again the thesis follows.

2. Let us consider the case $k = p$ prime and define

$$n' \doteq \begin{cases} pn & \text{if } p \mid n \\ n & \text{if } p \nmid n \end{cases}$$

We have:

$$n \in R_A \iff n' \in R_{pA}.$$

Let $p_1^{a_1} p_2^{a_2} \cdots p_k^{a_k} \in \mathbb{N}$ be powers of distinct primes. By remark we have:

$$p_i^{a_i} \in S_A \iff (p_i^{a_i})' \in S_{pA}.$$

Then, since $(p_1^{a_1} p_2^{a_2} \cdots p_k^{a_k})' = (p_1^{a_1})' (p_2^{a_2})' \cdots (p_k^{a_k})'$ we have the thesis. The general case follows by iterating the previous case for each first $p \mid k$.

□

We now lay the foundations for the next chapter, introducing the definition of periodic sets.

Definition 7 (periodic set). Let $(G, +)$ be an abelian group, $0 \in G$ the identity. A set $A \subset G$ is *periodic* if and only if there exists an element $g \in G$, $g \neq 0$, such that $g + A = A$. In this case, A is also called *periodic module* $g \in G$.

Definition 8 (basic form). The *basic form* of $A \subset \mathbb{Z}_n$ is the smallest (for reverse lexicographic order) circular permutation of the set of consecutive intervals in A ,

$$\Delta(A) = (a_2 - a_1, a_3 - a_2, \dots, a_k - a_{k-1}, a_1 - a_k)$$

where $0 \leq a_1 < a_2 < \dots < a_k < n$ are the elements of A , considered as numbers in $\llbracket 0, n-1 \rrbracket$.

Chapter 3

Vuza canons

3.1 Aperiodic factorisations

The definition of a tiling rhythmic canon as a factorization of a finite cyclic group with two of its subsets was given in Chapter 2. Effectively, the study of these musical structures comes under the broader subject of factorisations of an abelian group with n subsets. As pointed out in [11], when the Hungarian mathematician G. Hajós inquired in 1950 ([15]) if we can derive that A or B must be periodic given a factorisation $G = A \oplus B$ of an abelian group with two of its subsets, this topic was brought to the attention of the mathematical community. He answered the question in the negative in the same article.

Without being aware of Hajós' work, Nicolaas Govert de Bruijn, a Dutch mathematician, posed himself the identical question in 1950 and conjectured a positive solution (see [10]). Despite this first mistake, de Bruijn was later among the scholars who made a decisive contribution to the characterisation of the groups for which the answer to Hajós' question is positive.

Several examples of groups for which the answer is affirmative had been indeed exhibited since 1941 in other contexts and up to 1957 others appeared, in articles by Hajós ([14], [15], [16]), Rédei ([25], [26]), de Bruijn ([8], [10]), and Sands ([27], [28]), and the aforementioned Hajós' result on the groups for which it is negative was generalised, arriving at a complete characterisation in both cases.

Subsequently, after a long hiatus, between 1991 and 1993 a long paper in four parts by the Romanian mathematician Dan Tudor Vuza (see [29], [30], [31], and [32]) was published, dedicated to the formalisation of a particular class of rhythmic canons: the *RCCMCs* (*Regular Complementary Canons of Maximal Category*). The nature of Vuza's work is exceptional since he, completely ignoring the results of Hajós, Rédei, de Bruijn, and Sands, proves many of the theorems contained in the cited articles.

We will take a quick look at the findings immediately. Let us begin with some definitions.

Definition 9 (k -factorisation). Let G be an abelian group. A k -factorisation of G is a direct sum factorisation of G with k subsets of G . A k -factorisation $G = A_1 \oplus A_2 \oplus \dots \oplus A_k$

is said to be *periodic* if there is an index $i \in \{1, 2, \dots, k\}$ such that A_i is periodic. A non-periodic k -factorisation is called *aperiodic*.

Definition 10 (k -Hajós group). Let G be an abelian group. G is k -Hajós if all its k -factorisations are periodic. G is *non k -Hajós* if it is not a k -Hajós group, that is, if aperiodic k -factorisations of G exist. For $k = 2$, we will simply call them *Hajós* and *non-Hajós* groups.

Definition 11 (aperiodic canon). An *aperiodic canon* is an aperiodic 2-factorisation of a cyclic group. The order of the cyclic group is the *period* of the canon.

We observe that the aperiodic canons exist only for non-Hajós cyclic groups. We also note that an aperiodic canon is a rhythmic canon $\mathbb{Z}_n = A \oplus B$ in which both the inner rhythm A and the outer rhythm B are aperiodic.

The following proposition establishes a polynomial criterion for the periodicity of a given rhythm.

Proposition 2. *A set $A \subset \mathbb{Z}_n$ is periodic modulo $k \mid n$, if and only if*

$$\frac{x^n - 1}{x^k - 1} \mid A(x).$$

If we indicate the set $\{d \in \mathbb{N} \mid d \mid n\}$ by $\text{div}(n)$, Proposition 2 can be restated as:

Proposition 3. *A set $A \subset \mathbb{Z}_N$ is aperiodic if and only if for all $k \mid n$, $k \neq N$, we have*

$$\frac{x^n - 1}{x^k - 1} \nmid A(x),$$

that is, if and only if for all $k \in \text{div}(n) \setminus \{n\}$ there exists $d \in \text{div}(n) \setminus \text{div}(k)$ such that $\Phi_d(x) \nmid A(x)$.

Proof. By definition, $A \subset \mathbb{Z}_n$ is periodic modulo k if and only if $k + A = A$, and we have the following chain of double implications:

$$\begin{aligned} k + A = A &\iff x^k A(x) \equiv A(x) \pmod{x^n - 1} \\ &\iff (x^k - 1) A(x) \equiv 0 \pmod{x^n - 1} \\ &\iff x^n - 1 \mid (x^k - 1) A(x) \\ &\iff \frac{x^n - 1}{x^k - 1} \mid A(x) \end{aligned}$$

□

Theorem 2 (Tijdeman). *If $A \oplus B = \mathbb{Z}_n$ is a rhythmic canon, then also $kA \oplus B = \mathbb{Z}_n \forall k \in \mathbb{N}^*$ such that $(k, |A|) = 1$.*

For the proof, we need the following.

Lemma 7. *Let $A, B \subset \mathbb{N}$ be finite subsets, and $A(x), B(x)$ be the associated polynomials, $n \doteq A(1)B(1)$, and p be a prime such that $p \nmid A(1)$. If $A(x)B(x) \equiv \Delta_n(x) \pmod{x^n - 1}$, then*

$$A(x^p)B(x) \equiv \Delta_n(x) \pmod{x^n - 1}.$$

Proof. We consider the congruences:

$$\begin{aligned} A(x^p)B(x) &\equiv (A(x))^p B(x) \pmod{p} \\ &= (A(x))^{p-1} A(x)B(x) \pmod{p} \\ &\equiv (A(x))^{p-1} \Delta_n(x) \pmod{(x^n - 1, p)} \\ &\equiv (A(1))^{p-1} \Delta_n(x) \pmod{(x^n - 1, p)} \\ &\equiv \Delta_n(x) \pmod{(x^n - 1, p)}. \end{aligned}$$

Now let $r(x) = \sum_{i=0}^{n-1} r_i x^i$ be the remainder of the division of $A(x^p)B(x)$ by $x^n - 1$; for what has been said $r(x) \equiv \Delta_n(x) \pmod{p}$, i.e. $r_i \equiv 1 \pmod{p}$, and being $r(1) = A(1)B(1) = n$ we have $r_i = 1$ for each $i = 0, \dots, n-1$, that is the thesis. \square

Proof of Theorem 2. By hypothesis, $A(x)B(x) \equiv \Delta_n(x) \pmod{x^n - 1}$. First of all we observe that for every $h \in \mathbb{N}$, $(hA)(x) = A(x^h)$, in particular $(hA)(1) = A(1)$. Considering the factorisation of k , $k = p_1^{\alpha_1} p_2^{\alpha_2} \dots p_m^{\alpha_m}$, for each $i = 1, \dots, m$, $(p_i, |A|) = 1$. We can therefore iterate the application of Lemma 7 and we obtain

$$(kA)(x)B(x) \equiv \Delta_n(x) \pmod{x^n - 1},$$

that is $(kA) \oplus B = \mathbb{Z}_n$. \square

3.2 Vuza canons

An exhaustive construction method for aperiodic tiling rhythmic canons is not known to date; the first method to find some of them was provided by the following result (see [15] by Hajós, Theorem 1 in [10] by de Bruijn, and Proposition 2.2 in [29] by Vuza).

Theorem 3 (Hajós, de Bruijn, Vuza). *Let $n = p_1 n_1 p_2 n_2 n_3 \in \mathbb{N}$ such that*

1. $p_1, n_1, p_2, n_2, n_3 > 1$ and
2. $\gcd(p_1 n_1, p_2 n_2) = 1$.

Then \mathbb{Z}_n admits an aperiodic tiling rhythmic canon.

We give the proof of this theorem showing how to construct an aperiodic tiling rhythmic canon only for particular choices of factors A and B of \mathbb{Z}_n , which will be useful in the sequel, using the elegant factorisation suggested by Franck Jedrzejewski ([18]).

Theorem 4 (Hajós, de Bruijn, Vuza, Jedrzejewski). *In the hypotheses of Theorem 3, an example of tiling canon of \mathbb{Z}_n with two aperiodic subsets is given by the following construction. Indicating with \mathbb{I}_k the set $\{0, 1, \dots, k-1\}$, let us call:*

$$\begin{aligned} A_1 &= n_3 p_1 n_1 \mathbb{I}_{n_2} & A_2 &= n_3 p_2 n_2 \mathbb{I}_{n_1} \\ U_1 &= n_3 p_1 n_1 n_2 \mathbb{I}_{p_2} & U_2 &= n_3 p_2 n_2 n_1 \mathbb{I}_{p_1} \\ V_1 &= n_3 n_2 \mathbb{I}_{p_2} & V_2 &= n_3 n_1 \mathbb{I}_{p_1} \\ K_1 &= \{0\} & K_2 &= \{1, 2, \dots, n_3 - 1\}. \end{aligned}$$

Then taking

$$\begin{aligned} A &= A_1 \oplus A_2 \\ B &= (U_1 \oplus V_2 \oplus K_1) \sqcup (U_2 \oplus V_1 \oplus K_2) \end{aligned}$$

we have the aperiodic rhythmic canon $\mathbb{Z}_n = A \oplus B$.

Proof. First we list the general results that we will apply.

1. $\forall k \mid n$, \mathbb{I}_k is a complete set of representatives of $\mathbb{Z}_n/k\mathbb{Z}_n$, that is

$$\mathbb{Z}_n = \mathbb{I}_k \oplus k\mathbb{Z}_n,$$

(which, in fact, is the trivial canon).

2. $\forall k \in \mathbb{Z}^*$, if $\mathbb{Z}_n = S \oplus T$, then $k\mathbb{Z}_n = kS \oplus kT$.
3. If $\mathbb{Z}_n = S \oplus T$ then $\mathbb{Z}_n = kS \oplus T$ for every k such that $(k, |S|) = 1$.

The first two results are trivial, the third is Theorem 2.

So let $n = p_1 p_2 n_1 n_2 n_3$ as in the statement. We look for a factorisation $\mathbb{Z}_n = A \oplus B$ with A and B aperiodic. Let us start with the trivial canon:

$$\mathbb{Z}_n = \mathbb{I}_k \oplus k\mathbb{Z}_n.$$

First of all, applying 3, we have the following factorisations of \mathbb{Z}_n :

$$\begin{aligned} 1 : \mathbb{Z}_n &= \mathbb{I}_{n_1} \oplus n_1 \mathbb{Z}_n \\ &= p_2 n_2 \mathbb{I}_{n_1} \oplus n_1 \mathbb{Z}_n \\ 2 : \mathbb{Z}_n &= \mathbb{I}_{n_2} \oplus n_2 \mathbb{Z}_n \\ &= p_1 n_1 \mathbb{I}_{n_2} \oplus n_2 \mathbb{Z}_n \end{aligned}$$

Then, applying 1 and 2 alternately, we have the following factorisations of $n_3 \mathbb{Z}_n$:

$$\begin{aligned} 1 : n_3 \mathbb{Z}_n &= n_3 p_2 n_2 \mathbb{I}_{n_1} \oplus n_3 n_1 \mathbb{Z}_n \\ &= n_3 p_2 n_2 \mathbb{I}_{n_1} \oplus n_3 n_1 \mathbb{I}_{p_1} \oplus n_3 n_1 p_1 \mathbb{Z}_n \\ &= n_3 p_2 n_2 \mathbb{I}_{n_1} \oplus n_3 n_1 \mathbb{I}_{p_1} \oplus n_3 n_1 p_1 \mathbb{I}_{n_2} \oplus n_3 n_1 p_1 n_2 \mathbb{Z}_n; \\ 2 : n_3 \mathbb{Z}_n &= n_3 p_1 n_1 \mathbb{I}_{n_2} \oplus n_3 n_2 \mathbb{Z}_n \\ &= n_3 p_1 n_1 \mathbb{I}_{n_2} \oplus n_3 n_2 \mathbb{I}_{p_2} \oplus n_3 n_2 p_2 \mathbb{Z}_n \\ &= n_3 p_1 n_1 \mathbb{I}_{n_2} \oplus n_3 n_2 \mathbb{I}_{p_2} \oplus n_3 n_2 p_2 \mathbb{I}_{n_1} \oplus n_3 n_2 p_2 n_1 \mathbb{Z}_n. \end{aligned}$$

Then the two factorisations become:

1. $n_3\mathbb{Z}_n = A \oplus (U_1 \oplus V_2)$, and
2. $n_3\mathbb{Z}_n = A \oplus (U_2 \oplus V_1)$.

Going back to the initial factorisation, we obtain

$$\mathbb{Z}_n = \mathbb{I}_{n_3} \oplus n_3\mathbb{Z}_n = n_3\mathbb{Z}_n \sqcup \{1, \dots, n_3 - 1\} \oplus n_3\mathbb{Z}_n$$

where \sqcup indicates the disjoint union; we use the first and the second factorisations for the first and the second instance of $n_3\mathbb{Z}_n$, respectively, that is:

$$\begin{aligned} \mathbb{Z}_n &= A \oplus (U_1 \oplus V_2) \sqcup \{1, \dots, n_3 - 1\} \oplus A \oplus (U_2 \oplus V_1) \\ &= A \oplus ((U_1 \oplus V_2) \sqcup \{1, \dots, n_3 - 1\} \oplus (U_2 \oplus V_1)). \end{aligned}$$

Then taking

$$B \doteq (U_1 \oplus V_2) \sqcup \{1, \dots, n_3 - 1\} \oplus (U_2 \oplus V_1),$$

we have the canon $\mathbb{Z}_n = A \oplus B$.

We still need to prove that A and B are aperiodic. Let us start with A :

$$A(x) = \Delta_{n_1}(x^{n_3 p_2 n_2}) \Delta_{n_2}(x^{n_3 p_1 n_1}) = \frac{x^{n_3 p_2 n_2 n_1} - 1}{x^{n_3 p_2 n_2} - 1} \frac{x^{n_3 p_1 n_1 n_2} - 1}{x^{n_3 p_1 n_1} - 1}.$$

We use Proposition 3: we fix any $h \in \text{div}(n) \setminus \{n\}$ and look for a $d \in \text{div}(n) \setminus \text{div}(h)$ such that $\Phi_d(x) \nmid A(x)$.

We have the following cases:

1. $n_3 p_2 n_2 \nmid h$ and $\Phi_{n_3 p_2 n_2}(x) \nmid A(x)$;
2. $n_3 p_1 n_1 \nmid h$ and $\Phi_{n_3 p_1 n_1}(x) \nmid A(x)$.

There are no other possibilities, in fact, if absurdly we had $n_3 p_2 n_2 \mid h$ and $n_3 p_1 n_1 \mid h$, then $h = \alpha n_3 p_2 n_2 = \beta n_3 p_1 n_1$ and therefore $\alpha p_2 n_2 = \beta p_1 n_1$. Since $(p_1 n_1, p_2 n_2) = 1$, it would follow that $\alpha = p_1 n_1$ and $\beta = p_2 n_2$ and therefore $h = n$, which is absurd.

Let us move on to B :

$$\begin{aligned} B(x) &= (U_1 \oplus V_2)(x) + (x + x^2 + \dots + x^{n_3 - 1})(U_2 \oplus V_1)(x) \\ &= \Delta_{p_1}(x^{n_3 n_1}) \Delta_{p_2}\left(x^{\frac{n}{p_2}}\right) + x \Delta_{n_3 - 1}(x) \Delta_{p_2}(x^{n_3 n_2}) \Delta_{p_1}\left(x^{\frac{n}{p_1}}\right) \\ &= \frac{x^{n_3 p_1 n_1} - 1}{x^{n_3 n_1} - 1} \frac{x^n - 1}{x^{\frac{n}{p_2}} - 1} + x \Delta_{n_3 - 1}(x) \frac{x^{n_3 p_2 n_2} - 1}{x^{n_3 n_2} - 1} \frac{x^n - 1}{x^{\frac{n}{p_1}} - 1} \end{aligned}$$

As we did for A , given any $h \in \text{div}(n) \setminus \{n\}$, we look for a $d \in \text{div}(n) \setminus \text{div}(h)$ such that $\Phi_d(x) \nmid B(x)$. Let us consider the cases:

1. $n_3 p_2 n_2 n_1 \nmid h$ and $\Phi_{n_3 p_2 n_2 n_1}(x) \nmid B(x)$ since $\Phi_{n_3 p_2 n_2 n_1}(x) \mid \frac{x^n - 1}{x^{\frac{n}{p_2}} - 1}$ but $\Phi_{n_3 p_2 n_2 n_1}(x) \nmid x \Delta_{n_3 - 1}(x) \frac{x^{n_3 p_2 n_2} - 1}{x^{n_3 n_2} - 1} \frac{x^n - 1}{x^{\frac{n}{p_1}} - 1}$;

2. $n_3 p_1 n_1 n_2 \nmid h$ and $\Phi_{n_3 p_1 n_1 n_2}(x) \mid B(x)$ (symmetrically to the previous case).

There are no other possibilities, in fact, if absurdly we had $n_3 p_2 n_2 n_1 \mid h$ and $n_3 p_1 n_1 n_2 \mid h$, then $h = \alpha n_3 p_2 n_2 n_1 = \beta n_3 p_1 n_1 n_2$ and therefore $\alpha p_2 = \beta p_1$. Since $(p_1, p_2) = 1$, it would follow $\alpha = p_1$ and $\beta = p_2$ and so $h = n$, which is absurd. \square

Remark 3. From now on, given p_1, n_1, p_2, n_2 , and n_3 , we will denote by A_1, A_2, U_1, U_2, V_1 , and V_2 the sets so called in Example 4.

We therefore know that there exist aperiodic tiling rhythmic canons of period $n = p_1 n_1 p_2 n_2 n_3$, as in the hypothesis of Vuza's Theorem 3. The following result explicitly establishes which are the periods not included in the previous theorem.

Theorem 5 (Fidanza). *Let*

- $\mathcal{V} \doteq \{n \in \mathbb{N} : n = p_1 n_1 p_2 n_2 n_3 \text{ with } (p_1 n_1, p_2 n_2) = 1 \text{ and } p_1, p_2, n_1, n_2, n_3 > 1\}$, the set of natural numbers which satisfy the hypotheses of Vuza's theorem, and
- $\mathcal{H} \doteq \{p^\alpha, p^\alpha q, p^2 q^2, pqr, p^2 qr, pqr s : \alpha \in \mathbb{N}, p, q, r, s \text{ distinct primes}\}$,

then $\mathbb{N}^* = \mathcal{V} \sqcup \mathcal{H}$.

Proof. We set $\mathcal{V}^c = \mathbb{N}^* \setminus \mathcal{V}$ and $\mathcal{H}^c = \mathbb{N}^* \setminus \mathcal{H}$: it is sufficient to prove the two inclusions $\mathcal{H} \subset \mathcal{V}^c$ and $\mathcal{H}^c \subset \mathcal{V}$.

$\mathcal{V} \subset \mathcal{H}^c$: There are $p_1, p_2, n_1, n_2 \in \mathbb{N}^* \forall x \in \mathcal{V}$ with $(p_1 n_1, p_2 n_2) = 1$ and $p_1 n_1 p_2 n_2 \mid x$, and this property is not verified by the elements of \mathcal{H} of type p^α and $p^\alpha q$, with p, q primes and $\alpha \in \mathbb{N}$. Moreover, there are $p_1, p_2, n_1, n_2, n_3 \in \mathbb{N}^* \forall x \in \mathcal{V}$ such that $p_1 n_1 p_2 n_2 n_3 \mid x$, and this property is not verified by the remaining elements of \mathcal{H} , which are those of type $p^2 q^2, pqr, p^2 qr$ and $pqr s$, with p, q, r, s primes.

$\mathcal{H}^c \subset \mathcal{V}$: Let $x = p_1^{\alpha_1} p_2^{\alpha_2} \dots p_h^{\alpha_h} \in \mathcal{H}^c$, with p_1, p_2, \dots, p_h distinct primes. We consider the different cases, according to the number $h \geq 1$ of the primes that divide x .

$h = 1$: $x = p_1^{\alpha_1} \in \mathcal{H}$ so this case is impossible.

$h = 2$: We have $\alpha_1 \geq 3$ and $\alpha_2 \geq 2$ (or vice versa), so it is sufficient to consider $(p_1 n_1, p_2 n_2, n_3) = (p_1^2, p_2^{\alpha_2}, p_1^{\alpha_1 - 2})$.

$h = 3$: Up to a permutation of the factors, we have two cases:

* $\alpha_1 = 2, \alpha_2 \geq 2$ and $\alpha_3 \geq 1$, so it is sufficient to consider $(p_1 n_1, p_2 n_2, n_3) = (p_1^2, p_2^{\alpha_2}, p_3^{\alpha_3})$;

* $\alpha_1 \geq 3, \alpha_2 \geq 1$ and $\alpha_3 \geq 1$, so it is sufficient to consider $(p_1 n_1, p_2 n_2, n_3) = (p_1^2, p_2^{\alpha_2} p_3^{\alpha_3}, p_1^{\alpha_1 - 2})$.

$h = 4$: We have $\alpha_1 + \alpha_2 + \alpha_3 + \alpha_4 \geq 5$ and we assume $\alpha_1 \geq 2$, so it is enough to consider $(p_1 n_1, p_2 n_2, n_3) = (p_1^{\alpha_1}, p_2^{\alpha_2} p_3^{\alpha_3}, p_4^{\alpha_4})$.

$h > 4$: Just consider $(p_1 n_1, p_2 n_2, n_3) = (p_1^{\alpha_1} p_2^{\alpha_2}, p_3^{\alpha_3} p_4^{\alpha_4}, p_5^{\alpha_5})$.

□

We observe that all the examples of rhythmic canons encountered so far are not aperiodic, since their period is too small: the minimum period necessary for an aperiodic tiling rhythmic canon is 72, for which $(p_1, n_1, p_2, n_2, n_3) = (2, 2, 3, 3, 2)$.

Example 4. Theorem 4 gives the following factorisation of \mathbb{Z}_{72} :

$$\begin{aligned} A &= n_3 p_1 n_1 \mathbb{I}_{n_2} \oplus n_3 p_2 n_2 \mathbb{I}_{n_1} \\ &= 18 \{0, 1\} \oplus 8 \{0, 1, 2\} \\ &= \{0, 8, 16, 18, 26, 34\} \end{aligned}$$

$$\begin{aligned} B &= ((U_1 \oplus V_2) \sqcup \{1, \dots, n_3 - 1\}) \oplus (U_2 \oplus V_1) \\ &= (n_3 p_1 n_1 n_2 \mathbb{I}_{p_2} \oplus n_3 n_1 \mathbb{I}_{p_1}) \sqcup \{1, \dots, n_3 - 1\} \oplus n_3 n_2 \mathbb{I}_{p_2} \oplus n_3 n_1 p_2 n_2 \mathbb{Z}_n \\ &= 4 \{0, 1\} \oplus 24 \mathbb{Z}_{72} \sqcup \{1\} \oplus 6 \{0, 1, 2\} \oplus 36 \mathbb{Z}_{72} \\ &= \{0, 4, 24, 28, 48, 52\} \sqcup \{1\} \oplus \{0, 6, 12, 36, 42, 48\} \\ &= \{0, 1, 4, 7, 13, 24, 28, 37, 43, 48, 49, 52\}. \end{aligned}$$

We observe that the aperiodic factorisation constructed in Theorem 4 is symmetric with respect to $p_1 n_1$ and $p_2 n_2$, therefore as outer rhythm we can also consider

$$\begin{aligned} B' &= (U_2 \oplus V_1) \sqcup \{1, \dots, n_3 - 1\} \oplus (U_1 \oplus V_2) \\ &= n_3 n_2 \mathbb{I}_{p_2} \oplus n_3 n_1 p_2 n_2 \mathbb{Z}_n \sqcup \{1, \dots, n_3 - 1\} \oplus n_3 n_1 \mathbb{I}_{p_1} n_3 n_2 p_1 n_1 \mathbb{Z}_n \\ &= 6 \{0, 1, 2\} \oplus 36 \mathbb{Z}_{72} \sqcup \{1\} \oplus 4 \{0, 1\} \oplus 24 \mathbb{Z}_{72} \\ &= \{0, 6, 12, 36, 42, 48\} \sqcup \{1\} \oplus \{0, 4, 24, 28, 48, 52\} \\ &= \{0, 1, 5, 6, 12, 25, 29, 36, 42, 48, 49, 53\}. \end{aligned}$$

$\mathbb{Z}_{72} = A \oplus B'$ is in fact the factorisation shown by Laszlo Fuchs in *Abelian Groups*, and taken up by the Parisian mathematician François Le Lionnais, who inserts 72 in *Les Nombres Remarquables* precisely because "le groupe cyclique à soixante-douze éléments se décompose sous la forme $S + T$ non-périodiques".

The aperiodic canons with periods 72, 108, 120, 144, and 168 have been completely enumerated by Vuza [29], Friperntinger [12], Amiot [2], Kolountzakis and Matolcsi [21].

Many other ways of constructing aperiodic tiling canons are possible, see for example de Bruijn ([10]), Vuza ([29]), Fidanza ([11]), and Jedrzejewski ([18]). These methods fall into a category treated by F. Jedrzejewski (Theorem 14 in [19]).

In the next section, after briefly showing the two best known graphic representations used for tiling rhythmic canons, we introduce a new diagram representing the lattice of the cyclotomic factor indices of the characteristic polynomials of the canon.

3.3 Lattice representations

There are several ways to represent graphically a rhythmic canon. The main ones are the *circular representation* and the *grid representation*.

Figure 3.1a shows the circular representation (also called *Krenek diagram*) of \mathbb{Z}_n with n points equidistant along a circumference, starting from the pole and proceeding clockwise. A rhythmic pattern is represented by the polygon in such circumference whose vertices are the elements of the pattern, in our case, $\{0, 1, 5\}$. The other voices are added by rotating the pattern as indicated by the elements of the outer rhythm.

In Figure 3.1b, the inner voice is represented with a sequence of black boxes in a row of length n . The outer voice is represented by the starting black box in each row. This is the grid representation, also called *TUBS* (*Time Unit Box System*).

Let us now introduce a new type of representation of canons: a *lattice representation* through a *Hasse diagram*. In our context, we will call lattice representation of a rhythm the graphical representation of the divisors of the period of the canon, which can be considered a poset under the divisibility relation. For this poset, any edge in the diagram is such that the number below divides the number immediately above. In this diagram, we highlight the vertices representing the indices of the cyclotomic polynomials dividing the characteristic polynomial of the rhythm and the edges connecting them.

The lattice representation of a rhythm can tell us a lot about its structure. As a notable example, one can easily see that a rhythm is periodic if and only if its lattice representation contains a whole hyperplane (parallel to all axes but one) passing through the point corresponding to n . This is a very simple geometric (graphical) criterion that will prove valuable later. We have chosen to represent with the Hasse diagrams the rhythms of the aperiodic tiling rhythmic canons enumerated with periods ≤ 168 whose sets R_A do not include the index n .

Figure 3.1: Graphic representations of tiling rhythmic canons.

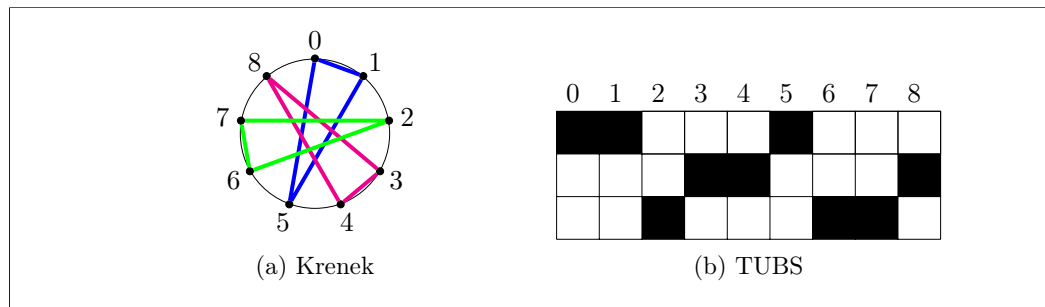
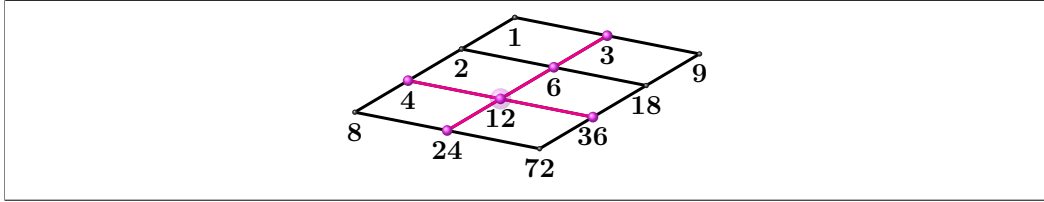
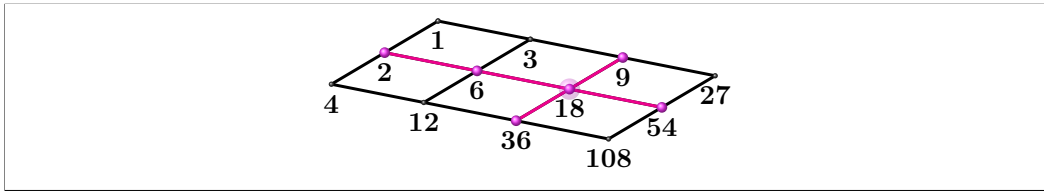

Figure 3.2: $n = 72$. $A_{CM} = 18\mathbb{I}_2 \oplus 8\mathbb{I}_3$.



$$S_A = \{3, 4\}. \#B = 6.$$

Figure 3.3: $n = 108$. $A_{CM} = 27\mathbb{I}_2 \oplus 12\mathbb{I}_3$.



$$S_A = \{2, 9\}. \#B = 252.$$

Figure 3.4: $n = 120$. $A = 30\mathbb{I}_2 \oplus 8\mathbb{I}_3$.

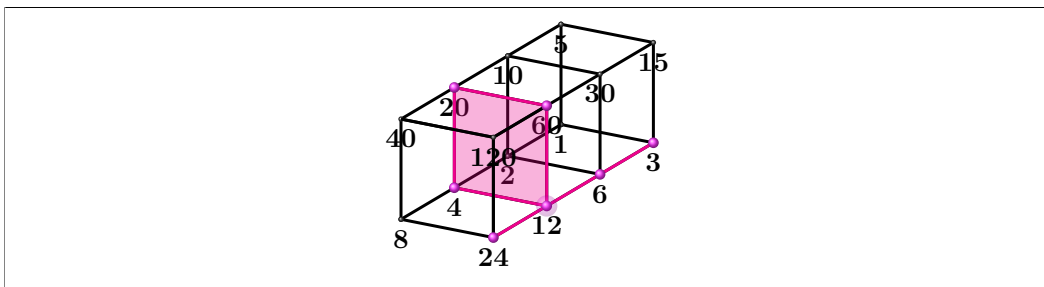

$$S_A = \{3, 4\}. \#B = 18.$$

Figure 3.5: $n = 120$. $A = 30\mathbb{I}_2 \oplus 8\mathbb{I}_5$.

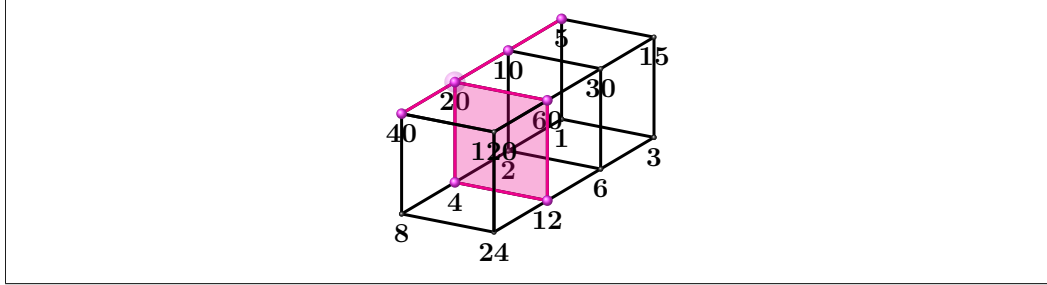

$$S_A = \{4, 5\}. \#B = 20.$$

Figure 3.6: $n = 144$. $A_{CM} = 18\mathbb{I}_2 \oplus 16\mathbb{I}_3$.

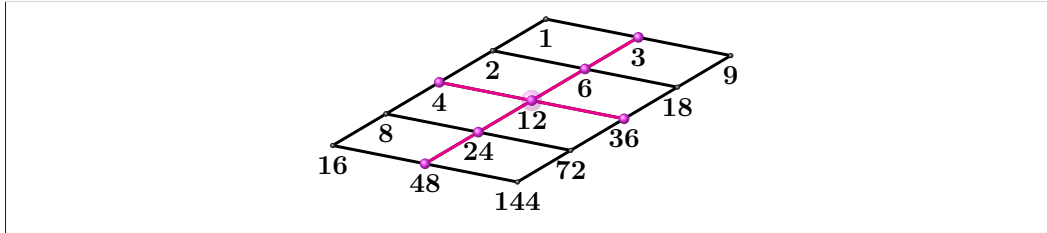

$$S_A = \{3, 4\}. \#B = 36.$$

Figure 3.7: $n = 144$. $A_{CM} = 36\mathbb{I}_2 \oplus 16\mathbb{I}_3$.

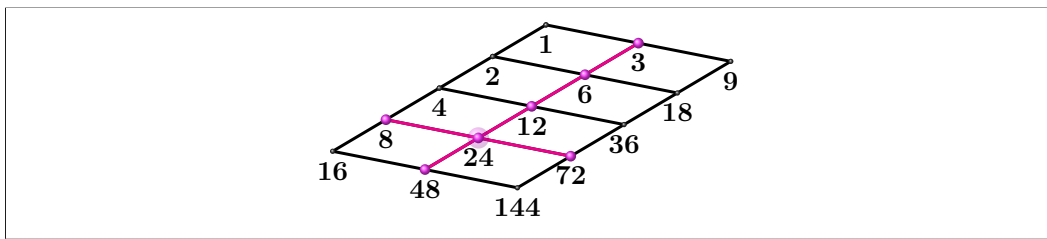

$$S_A = \{3, 8\}. \#B = 8640.$$

Figure 3.8: $n = 144$. $A_1 \oplus A_2 \oplus A_3 = 36\mathbb{I}_2 \oplus 16\mathbb{I}_3 \oplus A_3$.

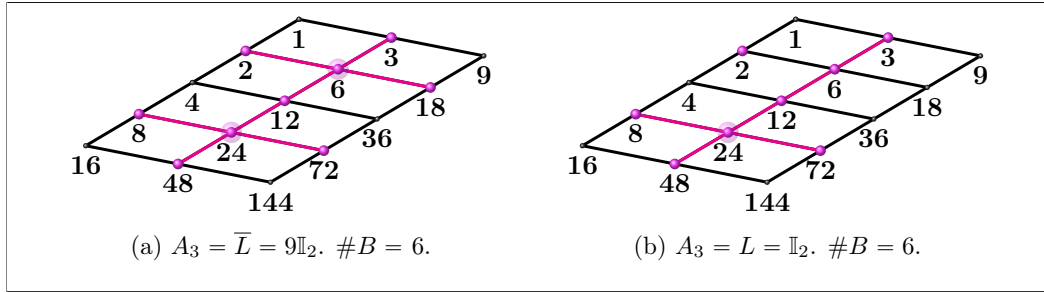

$$S_A = \{2, 3, 8\}.$$

Figure 3.9: $n = 144$. $A_1 \oplus A_2 \oplus 2A_3 = 36\mathbb{I}_2 \oplus 16\mathbb{I}_3 \oplus 2A_3$.

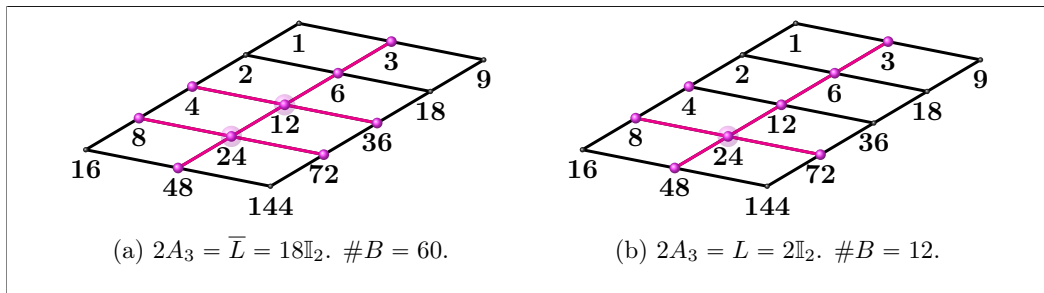

$$S_A = \{3, 4, 8\}.$$

Figure 3.10: $n = 168$. $A = 42\mathbb{I}_2 \oplus 8\mathbb{I}_3$.

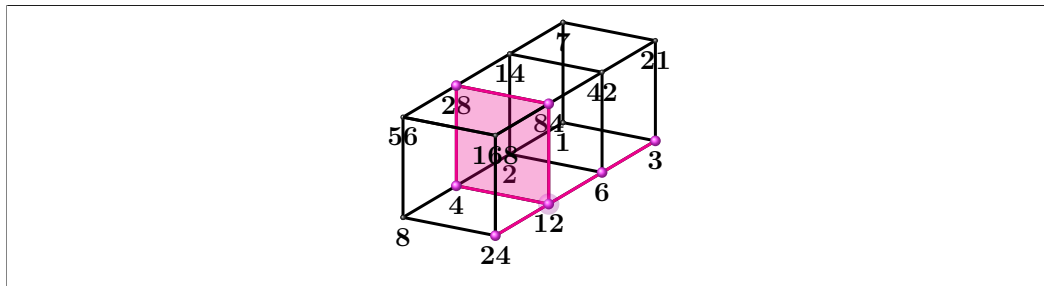

$$S_A = \{3, 4\}. \#B = 54.$$

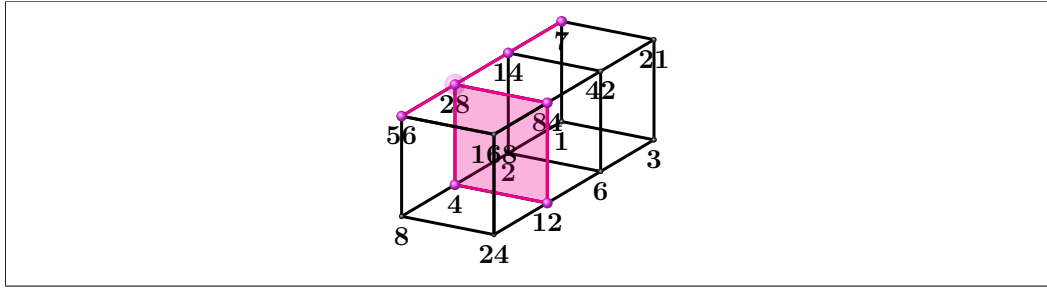
Figure 3.11: $n = 168$. $A = 42\mathbb{I}_2 \oplus 8\mathbb{I}_7$.

$$S_A = \{4, 7\}. \#B = 42.$$

3.4 Extended Vuza canons

We now give a first result that refines Jedrzejewski's one, lifting the hypothesis that p_1 and p_2 are prime and proving that B is aperiodic if n_3 satisfies a simple arithmetic constraint (see [22]).

Theorem 6. *Let $n = p_1 n_1 p_2 n_2 n_3 \in \mathbb{N}$ such that:*

1. $p_1, n_1, p_2, n_2, n_3 > 1$;
2. $\gcd(p_1 n_1, p_2 n_2) = 1$;
3. if n_3 is not prime, there is no prime q such that $q \mid n_3$, but $q \nmid p_1 n_1 p_2 n_2$.

Let H be the subgroup $H = n_3 \mathbb{I}_{p_1 n_1 p_2 n_2}$ of \mathbb{Z}_n and let K be a complete set of cosets representatives for \mathbb{Z}_n modulo H such that K is the disjoint union $K = K_1 \sqcup K_2$. Then the pair (A, B) defined by

$$\begin{aligned} A &= A_1 \oplus A_2 \\ B &= (U_1 \oplus V_2 \oplus K_1) \sqcup (U_2 \oplus V_1 \oplus K_2) \end{aligned}$$

is an aperiodic tiling rhythmic canon of \mathbb{Z}_n .

Proof. The proof that $A \oplus B = \mathbb{Z}_n$ and that the set A is aperiodic is the same as in Vuza (Proposition 2.2 in [29]). We are left to prove that B is aperiodic. Consider the characteristic polynomial $B(x)$:

$$B(x) = \frac{x^{n_3 p_1 n_1} - 1}{x^{n_3 n_1} - 1} \frac{x^n - 1}{x^{n_3 p_1 n_1 n_2} - 1} K_1(x) + \frac{x^{n_3 p_2 n_2} - 1}{x^{n_3 n_2} - 1} \frac{x^n - 1}{x^{n_3 p_2 n_2 n_1} - 1} K_2(x).$$

Given any $h \in \text{div}(n) \setminus \{n\}$, we look for a $d \in \text{div}(n) \setminus \text{div}(h)$ such that $\Phi_d(x) \nmid B(x)$. Let us consider the following cases:

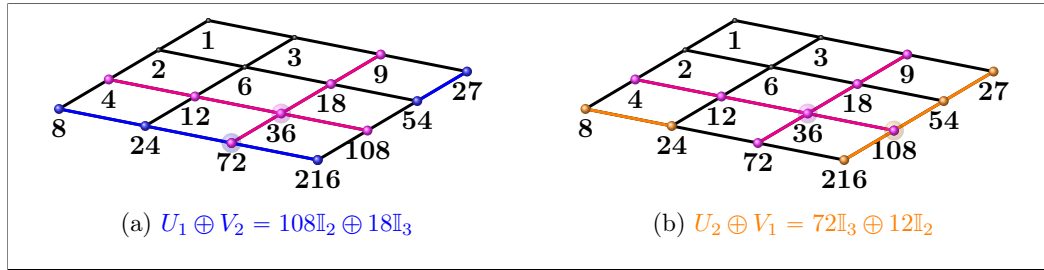
Figure 3.12: $n = 216$. $B = (U_1 \oplus V_2 \oplus K_1) \sqcup (U_2 \oplus V_1 \oplus K_2)$.

Lattice representation of an aperiodic tiling rhythmic canon with period $n = 216$, where $A = 54\mathbb{I}_2 \oplus 24\mathbb{I}_3$ and $B = (108\mathbb{I}_2 \oplus 18\mathbb{I}_3 \oplus \{21, 43, 122, 167\}) \sqcup (72\mathbb{I}_3 \oplus 12\mathbb{I}_2 \oplus \{0, 106\})$.

1. if $n_3 p_2 n_2 n_1 \nmid h$, then $\Phi_{n_3 p_2 n_2 n_1}(x) \nmid B(x)$ since

$$\Phi_{n_3 p_2 n_2 n_1}(x) \mid \frac{x^n - 1}{x^{n_3 p_1 n_1 n_2} - 1}$$

but

$$\Phi_{n_3 p_2 n_2 n_1}(x) \nmid \frac{x^{n_3 p_2 n_2} - 1}{x^{n_3 n_2} - 1} \frac{x^n - 1}{x^{n_3 p_2 n_2 n_1} - 1} K_2(x).$$

In particular, $\Phi_{n_3 p_2 n_2 n_1}(x) \nmid K_2(x)$ by Lemma 4 of Rédei's paper ([26]).

2. if $n_3 p_1 n_1 n_2 \nmid h$, then $\Phi_{n_3 p_1 n_1 n_2}(x) \mid B(x)$ (symmetrically to the previous case).

There are no other possibilities: in fact, if we had $n_3 p_2 n_2 n_1 \mid h$ and $n_3 p_1 n_1 n_2 \mid h$, then $h = \alpha n_3 p_2 n_2 n_1 = \beta n_3 p_1 n_1 n_2$ and therefore $\alpha p_2 = \beta p_1$. Since $\gcd(p_1, p_2) = 1$, it would follow that $\alpha = p_1$ and $\beta = p_2$ and so $h = n$, which is a contradiction. \square

Example 5. Consider $n = 216$; let $p_1 = 3$, $n_1 = 3$, $p_2 = 2$, $n_2 = 2$, and $n_3 = 6$. Theorem 6 ensures that, defining

$$A = 54\mathbb{I}_2 \oplus 24\mathbb{I}_3$$

$$B = (108\mathbb{I}_2 \oplus 18\mathbb{I}_3 \oplus \{21, 43, 122, 167\}) \sqcup (72\mathbb{I}_3 \oplus 12\mathbb{I}_2 \oplus \{0, 106\}),$$

$A \oplus B = \mathbb{Z}_{216}$ and (A, B) is an aperiodic tiling rhythmic canon.

In a generalisation of Theorem 6, rhythm B is the disjoint union of three sets, one being periodic both modulo n/p_1 and modulo n/p_2 .

Theorem 7. Let $n = p_1 n_1 p_2 n_2 n_3 \in \mathbb{N}$ such that:

1. $p_1, n_1, p_2, n_2, n_3 > 1$;
2. $\gcd(p_1 n_1, p_2 n_2) = 1$;
3. if n_3 is not prime, there is no prime q such that $q \mid n_3$, but $q \nmid p_1 n_1 p_2 n_2$.

Let H be the subgroup $H = n_3\mathbb{I}_{p_1n_1p_2n_2}$ of \mathbb{Z}_n , K be a complete set of cosets representatives for \mathbb{Z}_n modulo H such that K is the disjoint union $K = K_1 \sqcup K_2 \sqcup K_3$ with $K_1, K_2 \neq \emptyset$, and $W = n_3n_1n_2\mathbb{I}_{p_1p_2}$. Then the pair (A, B) defined by

$$\begin{aligned} A &= A_1 \oplus A_2 \\ B &= (U_1 \oplus V_2 \oplus K_1) \sqcup (U_2 \oplus V_1 \oplus K_2) \sqcup (W \oplus K_3) \end{aligned}$$

is an aperiodic tiling rhythmic canon of \mathbb{Z}_n .

Proof. The only case we need to consider is $K_3 \neq \emptyset$ (notice that this is possible only if $n_3 > 2$). Moreover, the case where n_3 is prime is very simple and we will omit its proof.

We already know, from Theorem 3 that A is aperiodic; B is aperiodic too, since

$$B(x) = U_1(x)V_2(x)K_1(x) + U_2(x)V_1(x)K_2(x) + W(x)K_3(x)$$

and the cyclotomic polynomials $\Phi_{n_3p_2n_2n_1}$ and $\Phi_{n_3p_1n_1n_2}$ divide exactly 2 of the summands on the right hand side.

We now prove that $A \oplus B = \mathbb{Z}_n$: to this aim we make use of the following facts, proven by F. Jedrzejewski (Theorem 14 in [19]):

$$\begin{aligned} A_1 + U_1 + V_2 &= A_1 + U_1 + U_2 \\ A_2 + U_2 + V_1 &= A_2 + U_2 + U_1. \end{aligned}$$

By an easy check, we see that

$$U_1 + U_2 = n_3n_1n_2(p_1\mathbb{I}_{p_2} + p_2\mathbb{I}_{p_1}) = n_3n_1n_2\mathbb{Z}_{p_1p_2} = W,$$

and $|U_1||U_2| = p_2p_1 = |W|$. This means that

$$U_1 \oplus U_2 = W.$$

We obtain that

$$\begin{aligned} A + B &= (A_1 + A_2) + ((U_1 + V_2 + K_1) \sqcup (U_2 + V_1 + K_2) \sqcup (W + K_3)) \\ &= (A_1 + A_2 + U_1 + V_2 + K_1) \sqcup (A_1 + A_2 + U_2 + V_1 + K_2) \sqcup \\ &\quad \sqcup (A_1 + A_2 + W + K_3) \\ &= (A_1 + A_2 + U_1 + U_2 + K_1) \sqcup (A_1 + A_2 + U_2 + U_1 + K_2) \sqcup \\ &\quad \sqcup (A_1 + A_2 + U_1 + U_2 + K_3) \\ &= A_1 + A_2 + U_1 + U_2 + (K_1 \sqcup K_2 \sqcup K_3) \\ &= A_1 + U_1 + A_2 + U_2 + K. \end{aligned}$$

Again, an easy computation shows that

$$(A_1 + U_1) + (A_2 + U_2) = n_3p_1n_1\mathbb{I}_{p_2n_2} + n_3p_2n_2\mathbb{I}_{p_1n_1} = n_3\mathbb{I}_{p_1n_1p_2n_2} = H$$

and so

$$A + B = H + K = \mathbb{Z}_n.$$

Moreover, since $|A||B| = n = |H||K|$, the sum $A + B$ is direct. \square

Figure 3.13: $n = 216$. $B = (U_1 \oplus V_2 \oplus K_1) \sqcup (U_2 \oplus V_1 \oplus K_2) \sqcup (W \oplus K_3)$.

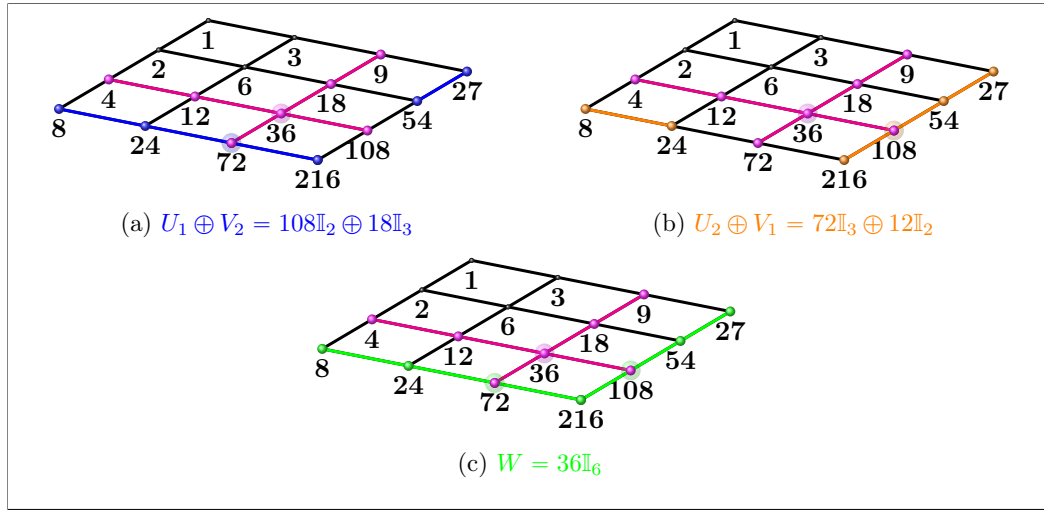

Lattice representation of an aperiodic tiling rhythmic canon with period $n = 216$, where $A = 54\mathbb{I}_2 \oplus 24\mathbb{I}_3$ and $B = (108\mathbb{I}_2 \oplus 18\mathbb{I}_3 \oplus \{21, 43\}) \sqcup (72\mathbb{I}_3 \oplus 12\mathbb{I}_2 \oplus \{0, 106\}) \sqcup (36\mathbb{I}_6 \oplus \{122, 167\})$.

Example 6. Let us go back to $n = 216$ with the same choices of p_1, n_1, p_2, n_2 , and n_3 . By Theorem 7, we find a new aperiodic tiling rhythmic canon (A, B) defining

$$A = 54\mathbb{I}_2 \oplus 24\mathbb{I}_3$$

$$B = (108\mathbb{I}_2 \oplus 18\mathbb{I}_3 \oplus \{21, 43\}) \sqcup (72\mathbb{I}_3 \oplus 12\mathbb{I}_2 \oplus \{0, 106\}) \sqcup (36\mathbb{I}_6 \oplus \{122, 167\}).$$

The second generalisation of Theorem 6 widens the definitions of sets A_1, A_2, V_1 , and V_2 . We precede it with a useful lemma.

Lemma 8. *Suppose that a subset $S \subseteq \mathbb{Z}_n$ is periodic of period $m \mid n$, i.e. $S + m = S$, and for $i = 0, \dots, k - 1$ let $S_i = \{a \in S : a \equiv i \pmod k\}$ where k is a divisor of m . Then for each i also the sets S_i are periodic of period m .*

Proof. It is sufficient to observe that since m is a multiple of k the remainder classes modulo k are invariant by the translation by m , hence also $S_i + m = S_i$. \square

Theorem 8. *Let $n = p_1 n_1 p_2 n_2 n_3 \in \mathbb{N}$ such that:*

1. $p_1, n_1, p_2, n_2, n_3 > 1$;
2. $\gcd(p_1 n_1, p_2 n_2) = 1$;
3. if n_3 is not prime, there is no prime q such that $q \mid n_3$, but $q \nmid p_1 n_1 p_2 n_2$.

Let H be the subgroup $H = n_3 \mathbb{I}_{p_1 n_1 p_2 n_2}$ of \mathbb{Z}_n , and $K = K_1 \sqcup K_2$ (with $K_1, K_2 \neq \emptyset$) be a complete set of cosets representatives for \mathbb{Z}_n modulo H . Take

- \tilde{A}_1 as a complete aperiodic set of coset representatives for $\mathbb{Z}_{p_2 n_2}$ modulo $n_2 \mathbb{I}_{p_2}$;
- \tilde{A}_2 as a complete aperiodic set of coset representatives for $\mathbb{Z}_{p_1 n_1}$ modulo $n_1 \mathbb{I}_{p_1}$;
- $\tilde{V}_1^1, \dots, \tilde{V}_1^j$ as complete aperiodic sets of coset representatives for $\mathbb{Z}_{p_2 n_1}$ modulo $p_2 \mathbb{I}_{n_1}$;
- $\tilde{V}_2^1, \dots, \tilde{V}_2^h$ as complete aperiodic sets of coset representatives for $\mathbb{Z}_{p_1 n_2}$ modulo $p_1 \mathbb{I}_{n_2}$.

Set $K_1 = K_1^1 \sqcup \dots \sqcup K_1^j$ and $K_2 = K_2^1 \sqcup \dots \sqcup K_2^h$, where $K_\alpha^s = \{k_\alpha^{j_s-1+1}, \dots, k_\alpha^{j_s}\}$ are non-empty subsets of K_α for $\alpha = 1, 2$. Then the pair (A, B) defined by

$$\begin{aligned}
 A &= n_3 p_1 n_1 \tilde{A}_1 \oplus n_3 p_2 n_2 \tilde{A}_2 \\
 B &= \left(\left(U_1 \oplus n_3 n_1 \tilde{V}_2^1 \oplus \{k_1^1, \dots, k_1^{l_1}\} \right) \sqcup \dots \right. \\
 &\quad \left. \dots \sqcup \left(U_1 \oplus n_3 n_1 \tilde{V}_2^j \oplus \{k_1^{l_{j-1}+1}, \dots, k_1^{|K_1|}\} \right) \right) \sqcup \\
 &\quad \left(\left(U_2 \oplus n_3 n_2 \tilde{V}_1^1 \oplus \{k_2^1, \dots, k_2^{m_1}\} \right) \sqcup \dots \right. \\
 &\quad \left. \dots \sqcup \left(U_2 \oplus n_3 n_2 \tilde{V}_1^h \oplus \{k_2^{m_{h-1}+1}, \dots, k_2^{|K_2|}\} \right) \right)
 \end{aligned}$$

is an aperiodic tiling rhythmic canon of \mathbb{Z}_n .

Proof. We have

- $n_3 p_1 n_1 \tilde{A}_1 + U_1 = n_3 p_1 n_1 \left(\tilde{A}_1 \oplus n_2 \mathbb{I}_{p_2} \right) = n_3 p_1 n_1 \mathbb{I}_{p_2 n_2} = A_1 + U_1$;
- $n_3 p_2 n_2 \tilde{A}_2 + U_2 = n_3 p_2 n_2 \left(\tilde{A}_2 \oplus n_1 \mathbb{I}_{p_1} \right) = n_3 p_2 n_2 \mathbb{I}_{p_1 n_1} = A_2 + U_2$;
- $A_1 + n_3 n_1 \tilde{V}_2 = n_3 n_1 \left(p_1 \mathbb{I}_{n_2} + \tilde{V}_2 \right) = n_3 n_1 \mathbb{I}_{p_1 n_2} = A_1 + V_2$;
- $A_2 + n_3 n_2 \tilde{V}_1 = n_3 n_2 \left(p_2 \mathbb{I}_{n_1} + \tilde{V}_1 \right) = n_3 n_2 \mathbb{I}_{p_2 n_1} = A_2 + V_1$.

For the sake of simplicity, we now give the proof in the case $j = 1$ and $h = 1$. The general

case is completely analogous. We compute

$$\begin{aligned}
A + B &= \\
&= \left(n_3 p_1 n_1 \tilde{A}_1 + n_3 p_2 n_2 \tilde{A}_2 \right) + \left((U_1 + n_3 n_1 \tilde{V}_2 + K_1) \sqcup (U_2 + n_3 n_2 \tilde{V}_1 + K_2) \right) \\
&= \left(n_3 p_1 n_1 \tilde{A}_1 + n_3 p_2 n_2 \tilde{A}_2 + U_1 + n_3 n_1 \tilde{V}_2 + K_1 \right) \sqcup \\
&\quad \sqcup \left(n_3 p_1 n_1 \tilde{A}_1 + n_3 p_2 n_2 \tilde{A}_2 + U_2 + n_3 n_2 \tilde{V}_1 + K_2 \right) \\
&= \left(A_1 + n_3 p_2 n_2 \tilde{A}_2 + U_1 + n_3 n_1 \tilde{V}_2 + K_1 \right) \sqcup \left(n_3 p_1 n_1 \tilde{A}_1 + A_2 + U_2 + n_3 n_2 \tilde{V}_1 + K_2 \right) \\
&= \left(A_1 + n_3 p_2 n_2 \tilde{A}_2 + U_1 + V_2 + K_1 \right) \sqcup \left(n_3 p_1 n_1 \tilde{A}_1 + A_2 + U_2 + V_1 + K_2 \right) \\
&= \left(A_1 + n_3 p_2 n_2 \tilde{A}_2 + U_1 + U_2 + K_1 \right) \sqcup \left(n_3 p_1 n_1 \tilde{A}_1 + A_2 + U_2 + U_1 + K_2 \right) \\
&= A_1 + A_2 + U_1 + U_2 + (K_1 \sqcup K_2) \\
&= A_1 + U_1 + A_2 + U_2 + K \\
&= \mathbb{Z}_n.
\end{aligned}$$

A cardinality argument similar to that used in Theorem 7 shows that the sum is direct.

The proof that A is aperiodic follows from Vuza's argument (Proposition 2.2 in [29]), as above. Assume now that B is periodic of period a : we can assume without loss of generality that $a = n/p$ where p is a prime number. Hypothesis 3 now implies that a is a multiple of n_3 : but then by Lemma 8 also the sets $B_i = B \cap (\{i\} + n_3 \mathbb{Z}_n)$ must be periodic of period a . However, the sets B_i are simply translates of $U_1 \oplus n_3 n_1 \tilde{V}_2$ by elements of K_1 or of $U_2 \oplus n_3 n_2 \tilde{V}_1$ by elements of K_2 (remember that also the elements of U_1 and U_2 are multiple of n_3): on their turn, $U_1 \oplus n_3 n_1 \tilde{V}_2$ and $U_2 \oplus n_3 n_2 \tilde{V}_1$ are indeed periodic resp. of period n/p_1 and n/p_2 , but since p_1 and p_2 are coprime no common period smaller than n is possible. A contradiction follows since we assumed both K_1 and K_2 to be non-empty. \square

Example 7. This time we choose $n = 252$; let $p_1 = 2$, $n_1 = 7$, $p_2 = 3$, $n_2 = 3$, and $n_3 = 2$. We can take e.g.

$$\begin{aligned}
\tilde{A}_1 &= \{0, 2, 7\} & \tilde{A}_2 &= \{0, 1, 3, 4, 9, 12, 13\} \\
\tilde{V}_1 &= \{0, 10, 17\} & \tilde{V}_2 &= \mathbb{I}_{p_1} = \{0, 1\} \\
K_1 &= \{0\} & K_2 &= \{1\}
\end{aligned}$$

obtaining a new canon (A, B) where

$$\begin{aligned}
A &= 28\tilde{A}_1 \oplus 18\tilde{A}_2 \\
&= \{0, 56, 196\} \oplus \{0, 18, 54, 72, 162, 216, 234\} \\
B &= \left(U_1 \oplus 14\tilde{V}_2 \oplus K_1 \right) \sqcup \left(U_2 \oplus 6\tilde{V}_1 \oplus K_2 \right) \\
&= (\{0, 84, 168\} \oplus \{0, 14\} \oplus \{0\}) \sqcup (\{0, 126\} \oplus \{0, 60, 102\} \oplus \{1\}).
\end{aligned}$$

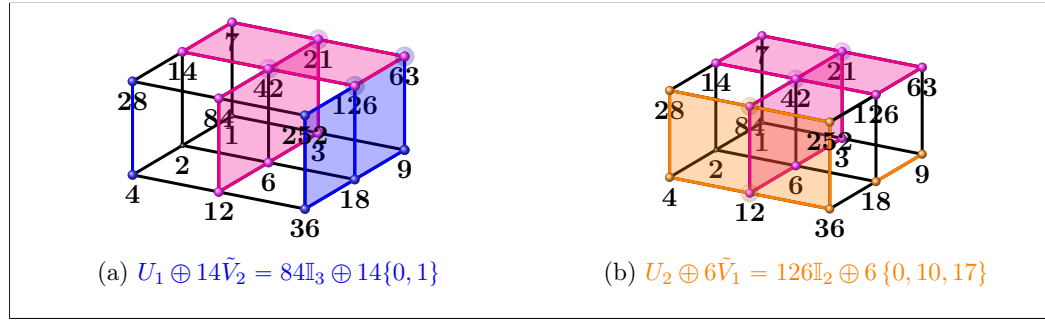
Figure 3.14: $n = 252$. $B = (U_1 \oplus 14\tilde{V}_2 \oplus K_1) \sqcup (U_2 \oplus 6\tilde{V}_1 \oplus K_2)$.

Lattice representation of an aperiodic tiling rhythmic canon with period $n = 252$, where $A = \{0, 56, 196\} \oplus \{0, 18, 54, 72, 162, 216, 234\}$ and $B = (84\mathbb{I}_3 \oplus \{0, 14\}) \sqcup (126\mathbb{I}_2 \oplus \{0, 60, 102\} \oplus \{1\})$.

Definition 12 (Vuza canon). We call *Vuza canons* all the canons obtained using the constructions described in Theorems 3, 6, 7, 8.

It is possible to stretch this type of constructions even further. With the following theorem, we improve the result of Jedrzejewski (Theorem 21 in [19]).

Theorem 9. Let $n = p_1 n_1 p_2 n_2 n_3 \in \mathbb{N}$ such that:

1. $p_1, n_1, p_2, n_2, n_3 > 1$;
2. $\gcd(p_1 n_1, p_2 n_2) = 1$;
3. there is no prime q such that $q \mid n_3$, but $q \nmid p_1 n_1 p_2 n_2$.

Let H be the subgroup $H = n_3 \mathbb{I}_{p_1 n_1 p_2 n_2}$ of \mathbb{Z}_n . Suppose that L and K are proper subsets of \mathbb{Z}_{n_3} such that $L \oplus K = \mathbb{Z}_{n_3}$ and $K = K_1 \sqcup K_2$, with $K_1, K_2 \neq \emptyset$. Then the pair (A, B) defined by

$$\begin{aligned} A &= A_1 \oplus A_2 \oplus L \\ B &= (U_1 \oplus V_2 \oplus K_1) \sqcup (U_2 \oplus V_1 \oplus K_2) \end{aligned}$$

is an aperiodic tiling rhythmic canon of \mathbb{Z}_n .

Proof.

$$\begin{aligned} A + B &= (A_1 + A_2 + L) + ((U_1 + V_2 + K_1) \sqcup (U_2 + V_1 + K_2)) \\ &= (A_1 + A_2 + L + U_1 + V_2 + K_1) \sqcup (A_1 + A_2 + L + U_2 + V_1 + K_2) \\ &= (A_1 + A_2 + L + U_1 + U_2 + K_1) \sqcup (A_1 + A_2 + L + U_2 + U_1 + K_2) \\ &= A_1 + A_2 + L + U_1 + U_2 + (K_1 \sqcup K_2) \\ &= A_1 + U_1 + A_2 + U_2 + L + K. \end{aligned}$$

Figure 3.15: $n = 216$. $A = A_1 \oplus A_2 \oplus L$.

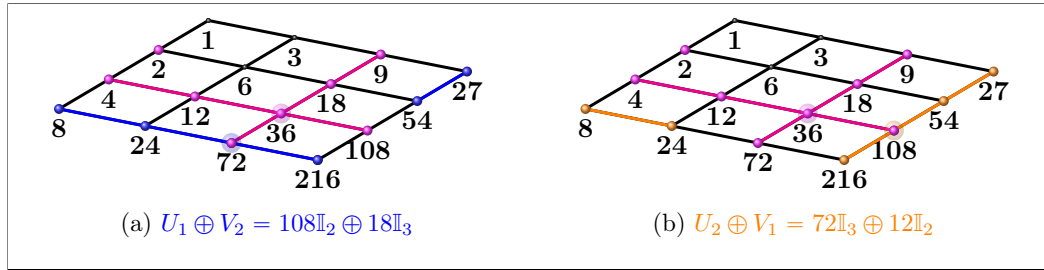

Lattice representation of an aperiodic tiling rhythmic canon with period $n = 216$, where $A = 54\mathbb{I}_2 \oplus 24\mathbb{I}_3 \oplus \mathbb{I}_2$ and $B = (108\mathbb{I}_2 \oplus 18\mathbb{I}_3 \oplus \{2\}) \sqcup (72\mathbb{I}_3 \oplus 12\mathbb{I}_2 \oplus \{0, 4\})$.

The sum is direct because the computation of the cardinality leads to

$$|A_1||A_2||U_1||U_2||L \oplus K| = n.$$

Aperiodicity of A is immediate from Lemma 8, since $A_1 + A_2$ is aperiodic and B is the union of the subsets B_i contained in different remainder classes modulo n_3 , some of which have a period coprime with the period of the other ones (exactly as in the previous theorem). \square

Example 8. Choosing again $n = 216$ and the same values for p_1, n_1, p_2, n_2 , and n_3 as in Example 6, we set $L = \{0, 1\}$, $K_1 = \{2\}$, and $K_2 = \{0, 4\}$. By Theorem 9, we get that

$$\begin{aligned} A &= 54\mathbb{I}_2 \oplus 24\mathbb{I}_3 \oplus L \\ B &= (108\mathbb{I}_2 \oplus 18\mathbb{I}_3 \oplus K_1) \sqcup (72\mathbb{I}_3 \oplus 12\mathbb{I}_2 \oplus K_2) \end{aligned}$$

define an aperiodic tiling rhythmic canon.

To prove our next result we take advantage of the equivalent polynomial formulation of tilings and of the Coven-Meyerowitz conditions ([9]).

Definition 13 (extension). Let A be a subset of \mathbb{Z}_n and let $S_A = \{p^\alpha, q^\beta, \dots, r^\gamma\}$. We call the *extension of A* any rhythm \bar{A} whose characteristic polynomial is

$$\bar{A}(x) = \Phi_{p^\alpha} \left(x^{\frac{n}{p^\alpha k_p}} \right) \Phi_{q^\beta} \left(x^{\frac{n}{q^\beta k_q}} \right) \cdots \Phi_{r^\gamma} \left(x^{\frac{n}{r^\gamma k_r}} \right),$$

where k_p, k_q, \dots, k_r are divisors of n such that $p \nmid k_p, q \nmid k_q, \dots, r \nmid k_r$.

Note that by definition clearly $S_A = S_{\bar{A}}$.

Proposition 4. Let $A \oplus B = \mathbb{Z}_n$ and let B satisfy condition (T2). Then $\bar{A} \oplus B = \mathbb{Z}_n$, too.

Proof. Since p^α is a prime power, then

$$\Phi_{p^\alpha} \left(x^{\frac{n}{p^\alpha k p}} \right) \in \{0, 1\} [x],$$

and so $\bar{A}(x) \in \mathbb{N}[x]$. Moreover,

- $\bar{A}(1)B(1) = n$ and
- $\Phi_d(x) \mid \bar{A}(x)B(x)$ for all $d \mid n$, with $d > 1$.

By Lemma 2, this means that

$$\bar{A}(x)B(x) \equiv \sum_{k=0}^{n-1} x^k \pmod{(x^n - 1)},$$

that is, condition (T0) in Lemma 1 holds. Therefore $\bar{A}(x) \in \{0, 1\} [x]$ and $\bar{A} \oplus B = \mathbb{Z}_n$, that is, \bar{A} tiles with B . \square

Combining Theorem 9 and Proposition 4, we are able to find new Vuza canons where L is not a subset of \mathbb{Z}_{n_3} .

Theorem 10. *Let $n = p_1 n_1 p_2 n_2 n_3 \in \mathbb{N}$ such that:*

1. $p_1, n_1, p_2, n_2, n_3 > 1$;
2. $\gcd(p_1 n_1, p_2 n_2) = 1$;
3. *there is no prime q such that $q \mid n_3$, but $q \nmid p_1 n_1 p_2 n_2$.*

Let H be the subgroup $H = n_3 \mathbb{I}_{p_1 n_1 p_2 n_2}$ of \mathbb{Z}_n . Suppose that L and K are proper subsets of \mathbb{Z}_{n_3} such that $L \oplus K = \mathbb{Z}_{n_3}$ and $K = K_1 \sqcup K_2$, with $K_1, K_2 \neq \emptyset$. Let \bar{L} be an extension of L ; then the pair (A, B) defined by

$$\begin{aligned} A &= A_1 \oplus A_2 \oplus \bar{L} \\ B &= (U_1 \oplus V_2 \oplus K_1) \sqcup (U_2 \oplus V_1 \oplus K_2) \end{aligned}$$

is an aperiodic tiling rhythmic canon of \mathbb{Z}_n .

Proof. Since, by definition, A_1 and A_2 coincide with their own extensions, the extension of $A_1 \oplus A_2 \oplus L$ is A . By Theorem 9, $A_1 \oplus A_2 \oplus L \oplus B = \mathbb{Z}_n$, therefore Proposition 4 implies that $A \oplus B = \mathbb{Z}_n$.

We already know from Theorem 9 that B is aperiodic. To show that A is aperiodic, consider $\bar{L}(x)$. By hypothesis 3, $S_{\bar{L}}$ does not contain any maximal prime power dividing n , as S_{A_1} and S_{A_2} . As a consequence, $S_A = S_{A_1} \cup S_{A_2} \cup S_{\bar{L}}$ does not contain any such prime power, either. By Proposition 3, A cannot be periodic. \square

Definition 14 (extended Vuza canon). We call *extended Vuza canons* all the canons obtained using the constructions of Theorems 9 and 10, possibly combined with those of Theorems 3, 6, 7 and 8.

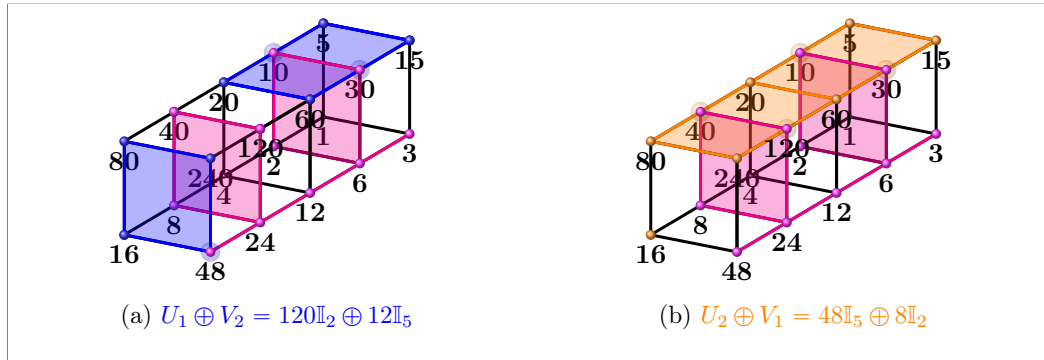
Figure 3.16: $n = 240$. $A = A_1 \oplus A_2 \oplus \bar{L}$.

Lattice representation of an aperiodic tiling rhythmic canon with period $n = 240$, where $A = 60\mathbb{I}_2 \oplus 16\mathbb{I}_3 \oplus 15\mathbb{I}_2$ and $B = (120\mathbb{I}_2 \oplus 12\mathbb{I}_5 \oplus \{2\}) \sqcup (48\mathbb{I}_5 \oplus 8\mathbb{I}_2 \oplus \{0\})$.

Example 9. We show now an extended Vuza canon with period $n = 240$ ($p_1 = 5, n_1 = 3, p_2 = 2, n_2 = 2, n_3 = 4$). Set $L = \mathbb{I}_2$; then $\bar{L} = 15\mathbb{I}_2$. Choosing $K_1 = \{2\}$ and $K_2 = \{0\}$, we obtain the canon

$$\begin{aligned} A &= A_1 \oplus A_2 \oplus \bar{L} \\ &= 60\mathbb{I}_2 \oplus 16\mathbb{I}_3 \oplus 15\mathbb{I}_2 \\ B &= (U_1 \oplus V_2 \oplus K_1) \sqcup (U_2 \oplus V_1 \oplus K_2) \\ &= (120\mathbb{I}_2 \oplus 12\mathbb{I}_5 \oplus \{2\}) \sqcup (48\mathbb{I}_5 \oplus 8\mathbb{I}_2 \oplus \{0\}). \end{aligned}$$

It is worth noting that it would not be possible to obtain such a canon without applying Theorem 10.

Example 10. Given $L \oplus K = \mathbb{I}_2 \oplus 2\mathbb{I}_2 = \mathbb{Z}_4$, an extended Vuza canon with period $n = 144$ is

$$\begin{aligned} A &= A_1 \oplus A_2 \oplus L \\ &= 16\mathbb{I}_3 \oplus 36\mathbb{I}_2 \oplus \mathbb{I}_2. \\ B &= (U_1 \oplus V_2 \oplus K_1) \sqcup (U_2 \oplus V_1 \oplus K_2) \\ &= (48\mathbb{I}_3 \oplus 8\mathbb{I}_2 \oplus \{0\}) \sqcup (72\mathbb{I}_2 \oplus 12\mathbb{I}_3 \oplus \{2\}). \end{aligned}$$

The lattice representation of A is in Figure 3.17.

It is now natural to pose the following question: how many extended Vuza canons are there given the five parameters p_1, n_1, p_2, n_2, n_3 and the factorisation $\mathbb{Z}_{n_3} = L \oplus K$?

The first step consists in determining how many partitions of \mathbb{Z}_{n_3} allow to disjointly distribute the n_3 remainder classes in the factors $(U_1 \oplus n_3 n_1 \tilde{V}_2^j)$, $(U_2 \oplus n_3 n_2 \tilde{V}_1^h)$ and W , paying attention to assign at least one class to the first two factors (otherwise the

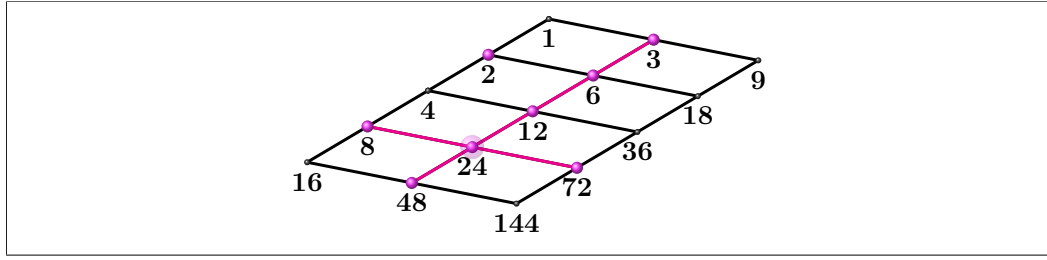
Figure 3.17: $n = 144$. $A = 16\mathbb{I}_3 \oplus 36\mathbb{I}_2 \oplus \mathbb{I}_2$.

$$S_A = \{2, 3, 8\}.$$

canon would become periodic). By Theorem 8, we need also to consider all the different \tilde{V}_1^j and \tilde{V}_2^h which provide a (extended) Vuza canon. We want to determine in how many ways we can choose aperiodic subsets of distinct elements modulo p_1 in $\mathbb{Z}_{p_1 n_2}$ (resp. in $\mathbb{Z}_{p_2 n_1}$) up to translation. By convention, we fix the first element as 0, and for every other remainder class modulo p_1 we have n_2 possibilities. We have to disregard the periodic ones and finally we discard all the $p_1 - 1$ possible translations. Then,

$$\begin{aligned} \#\tilde{V}_1 &= \frac{1}{p_2} \sum_{u|p_2} \mu\left(\frac{p_2}{u}\right) \left(n_1^{(u-1)} - 1\right) \\ \#\tilde{V}_2 &= \frac{1}{p_1} \sum_{v|p_1} \mu\left(\frac{p_1}{v}\right) \left(n_2^{(v-1)} - 1\right). \end{aligned}$$

When there is no factor \bar{L} in the inner rhythm A , we consider

$$T = \begin{bmatrix} t_{11} & t_{12} & t_{13} \\ t_{21} & t_{22} & t_{23} \\ \vdots & \vdots & \vdots \\ t_{m1} & t_{m2} & t_{m3} \end{bmatrix}$$

as the matrix in which every row t_i , with $i = 1, \dots, m$, represents a possible partition of the remainder classes modulo n_3 , and the single entry in every row is the number of remainder classes modulo n_3 assigned to the i -th factor

$$U_1 \oplus n_3 n_1 \tilde{V}_2^j, \quad U_2 + n_3 n_2 \tilde{V}_1^h, \quad \text{or } W.$$

In this case, the number of possible outer rhythms B is as follows:

$$\#B = \frac{\#K}{n} \sum_{1 \leq i \leq m} \left(\frac{n}{n_3 \cdot p_1} \cdot \#\tilde{V}_1\right)^{t_{i1}} \cdot \left(\frac{n}{n_3 \cdot p_2} \cdot \#\tilde{V}_2\right)^{t_{i2}} \cdot \left(\frac{n}{n_3 \cdot p_1 \cdot p_2}\right)^{t_{i3}} \cdot \binom{n_3}{\mathbf{t}_i}.$$

Example 11. Let us show how many aperiodic rhythms B there exist given $n_1 = 2, n_2 = 3, n_3 = 5, p_1 = 2, p_2 = 3$. The possible vectors t for \mathbb{Z}_{n_3} are 10:

$$T = \{[1, 4, 0], [4, 1, 0], \\ [2, 3, 0], [3, 2, 0], \\ [1, 2, 2], [2, 1, 2], [2, 2, 1], \\ [1, 1, 3], [1, 3, 1], [3, 1, 3]\}.$$

The total number of possible aperiodic rhythms B is given by:

$$\begin{aligned} \#B &= \frac{1}{180} \sum_{1 \leq i \leq 10} \left(\frac{180}{5 \cdot 2} \cdot 1\right)^{t_{i1}} \left(\frac{180}{5 \cdot 3} \cdot 1\right)^{t_{i2}} \left(\frac{180}{5 \cdot 2 \cdot 3}\right)^{t_{i3}} \binom{5}{\mathbf{t}_i} \\ &= 45360 + 77760 + 85536 + 72576 \\ &= 281232. \end{aligned}$$

Example 12. Given, instead, $n_1 = 2, n_2 = 3, n_3 = 4, p_1 = 2, p_2 = 3$, we calculate how many aperiodic rhythms B there exist in \mathbb{Z}_{144} . The possible vectors t for \mathbb{Z}_{n_3} are 6:

$$T = \{[1, 3, 0], [3, 1, 0], \\ [2, 2, 0], [1, 1, 2], \\ [1, 2, 1], [2, 1, 1]\}.$$

The total number of possible extended Vuza aperiodic rhythms B is given by:

$$\begin{aligned} \#B &= \frac{1}{144} \sum_{1 \leq i \leq 6} \left(\frac{144}{8} \cdot 1\right)^{t_{i1}} \left(\frac{144}{12} \cdot 1\right)^{t_{i2}} \left(\frac{144}{24}\right)^{t_{i3}} \binom{4}{\mathbf{t}_i} \\ &= 864 + 1944 + 1944 + 648 + 1296 + 1944 \\ &= 8640. \end{aligned}$$

We include a table showing the number of Vuza canons and extended Vuza canons for all the periods n with values between 72 and 280.

Theorem 11. *Let $A \oplus B = \mathbb{Z}_n$ be a Vuza canon. Then A and B satisfy condition (T2).*

Proof.

B is (T2): Let $A_1 \doteq n_3 p_2 n_2 \mathbb{I}_{n_1}$ and $A_2 \doteq n_3 p_1 n_1 \mathbb{I}_{n_2}$. Then, as in the proof of Theorem 4, we consider $A = A_1 \oplus A_2$. Since

$$\begin{aligned} A(x) &= \frac{x^{n_3 p_2 n_2 n_1} - 1}{x^{n_3 p_2 n_2} - 1} \frac{x^{n_3 p_1 n_1 n_2} - 1}{x^{n_3 p_1 n_1} - 1} \\ &= \prod_{\substack{d_1 | n_3 p_2 n_2 n_1 \\ d_1 \nmid n_3 p_2 n_2}} \Phi_{d_1}(x) \prod_{\substack{d_2 | n_3 p_1 n_1 n_2 \\ d_2 \nmid n_3 p_1 n_1}} \Phi_{d_2}(x), \end{aligned}$$

it follows that $\forall d_1$ with prime powers factorisation $d_1 = p_1^{\alpha_1} \cdots p_k^{\alpha_k}$ such that $\Phi_{d_1}(x) \mid A(x)$, there is a prime power $p_1^{\alpha_1} \mid n_1 n_3$ such that $\Phi_{p_1^{\alpha_1}} \mid A(x)$. Similarly for d_2 . Then $B(x)$ satisfies condition (T2).

Table 3.1: All possible \tilde{A}_1 and \tilde{A}_2 for some non-Hajós values of $n \leq 168$.

n	p_1	n_1	p_2	n_2	n_3	L	$\#K$	$\#A$	$n_3 p_1 n_1 \tilde{A}_1$	$n_3 p_2 n_2 \tilde{A}_2$
72	3	3	2	2	2	{0}	0	3	$18\mathbb{I}_2$	$8\mathbb{I}_3$ $8\{0, 2, 4\}$ $8\{0, 1, 5\}$
108	3	3	2	2	3	{0}	0	3	$27\mathbb{I}_2$	$12\mathbb{I}_3$ $12\{0, 2, 4\}$ $12\{0, 1, 5\}$
120	3	5	2	2	2	{0}	0	16	$30\mathbb{I}_2$	$8\mathbb{I}_5$ $8\{0, 2, 3, 4, 6\}$ $8\{0, 1, 3, 4, 7\}$ $8\{0, 3, 4, 6, 7\}$ $8\{0, 1, 2, 4, 8\}$ $8\{0, 2, 4, 6, 8\}$ $8\{0, 1, 4, 7, 8\}$ $8\{0, 4, 6, 7, 8\}$ $8\{0, 1, 2, 3, 9\}$ $8\{0, 2, 3, 6, 9\}$ $8\{0, 1, 3, 7, 9\}$ $8\{0, 3, 6, 7, 9\}$ $8\{0, 1, 2, 8, 9\}$ $8\{0, 2, 6, 8, 9\}$ $8\{0, 3, 4, 7, 11\}$ $8\{0, 2, 4, 8, 11\}$
	5	3	2	2	2	{0}	0	8	$30\mathbb{I}_2$	$8\mathbb{I}_3$ $8\{0, 2, 4\}$ $8\{0, 1, 5\}$ $8\{0, 4, 5\}$ $8\{0, 2, 7\}$ $8\{0, 5, 7\}$ $8\{0, 1, 8\}$ $8\{0, 4, 8\}$
144	3	3	2	2	4	{0} {0, 1}	0 2	3	$36\mathbb{I}_2$	$16\mathbb{I}_3$ $16\{0, 2, 4\}$ $16\{0, 1, 5\}$
	3	3	2	4	2	{0}	0	6	$18\mathbb{I}_4$ $18\{0, 2, 3, 5\}$	$16\mathbb{I}_3$ $16\{0, 2, 4\}$ $16\{0, 1, 5\}$
	3	3	4	2	2	{0}	0	6	$18\mathbb{I}_2$ $18\{0, 3\}$	$16\mathbb{I}_3$ $16\{0, 2, 4\}$ $16\{0, 1, 5\}$
168	7	3	2	2	2	{0}	0	16	$42\mathbb{I}_2$	$8\mathbb{I}_3$ $8\{0, 2, 4\}$ $8\{0, 1, 5\}$ $8\{0, 4, 5\}$ $8\{0, 2, 7\}$ $8\{0, 5, 7\}$ $8\{0, 1, 8\}$ $8\{0, 4, 8\}$ $8\{0, 7, 8\}$ $8\{0, 2, 10\}$ $8\{0, 5, 10\}$ $8\{0, 8, 10\}$ $8\{0, 1, 11\}$ $8\{0, 4, 11\}$ $8\{0, 7, 11\}$ $8\{0, 5, 13\}$

Table 3.2: All possible \tilde{A}_1 and \tilde{A}_2 for $n = 180$.

n	p_1	n_1	p_2	n_2	n_3	L	$\#K$	$\#A$	$n_3 p_1 n_1 \tilde{A}_1$	$n_3 p_2 n_2 \tilde{A}_2$
	3	3	2	5	2	{0}	0	9	$18\mathbb{I}_5$ $18\{0, 1, 3, 4, 7\}$ $18\{0, 1, 2, 4, 8\}$	$20\mathbb{I}_3$ $20\{0, 2, 4\}$ $20\{0, 1, 5\}$
	3	3	5	2	2	{0}	0	6	$18\mathbb{I}_2$ $18\{0, 3\}$	$20\mathbb{I}_3$ $20\{0, 2, 4\}$ $20\{0, 1, 5\}$
180	3	5	2	2	3	{0}	0	16	$45\mathbb{I}_2$	$12\mathbb{I}_5$ $12\{0, 2, 3, 4, 6\}$ $12\{0, 1, 3, 4, 7\}$ $12\{0, 3, 4, 6, 7\}$ $12\{0, 1, 2, 4, 8\}$ $12\{0, 2, 4, 6, 8\}$ $12\{0, 1, 4, 7, 8\}$ $12\{0, 4, 6, 7, 8\}$ $12\{0, 1, 2, 3, 9\}$ $12\{0, 2, 3, 6, 9\}$ $12\{0, 1, 3, 7, 9\}$ $12\{0, 3, 6, 7, 9\}$ $12\{0, 1, 2, 8, 9\}$ $12\{0, 2, 6, 8, 9\}$ $12\{0, 3, 4, 7, 11\}$ $12\{0, 2, 4, 8, 11\}$
	5	3	2	2	3	{0}	0	8	$45\mathbb{I}_2$	$12\mathbb{I}_3$ $12\{0, 2, 4\}$ $12\{0, 1, 5\}$ $12\{0, 4, 5\}$ $12\{0, 2, 7\}$ $12\{0, 5, 7\}$ $12\{0, 1, 8\}$ $12\{0, 4, 8\}$
	3	3	2	2	5	{0}	0	3	$45\mathbb{I}_2$	$20\mathbb{I}_3$ $20\{0, 2, 4\}$ $20\{0, 1, 5\}$

A is (T2) : By definition,

$$R_{A_1} = \{f \in \mathbb{N}^* : f \mid n_3 p_2 n_2 n_1 \text{ and } f \nmid n_3 p_2 n_2\},$$

$$R_{A_2} = \{g \in \mathbb{N}^* : g \mid n_3 p_1 n_1 n_2 \text{ and } g \nmid n_3 p_1 n_1\},$$

and

$$S_{A_1} = \{p^\alpha \in R_{A_1} : p \text{ prime}, \alpha \in \mathbb{N}^*, p^\alpha \mid n_3 p_2 n_2 n_1, \text{ and } p^\alpha \nmid n_3 p_2 n_2\},$$

$$S_{A_2} = \{q^\beta \in R_{A_2} : q \text{ prime}, \beta \in \mathbb{N}^*, q^\beta \mid n_3 p_1 n_1 n_2, \text{ and } q^\beta \nmid n_3 p_1 n_1\}.$$

Let us start with S_{A_1} : since $(p_2 n_2, n_1) = 1$,

$$\begin{aligned} S_{A_1} &= \{p^\alpha \in R_{A_1} : p^\alpha \mid n_3 p_2 n_2, p^\alpha \nmid n_3 p_2 n_2\} \cup \{p^\alpha \in R_{A_1} : p^\alpha \mid n_3 n_1, p^\alpha \nmid n_3 p_2 n_2\} \\ &= \{p^\alpha \in R_{A_1} : p^\alpha \mid n_3 n_1, p^\alpha \nmid n_3 p_2 n_2\} \\ &= \{p^\alpha \in R_{A_1} : p^\alpha \mid n_3 n_1, p^\alpha \nmid n_3\}. \end{aligned}$$

Similarly,

$$S_{A_2} = \{q^\beta \in R_{A_2} : q^\beta \mid n_3 n_2, q^\beta \nmid n_3\}.$$

Then, consider any product of powers of distinct primes $p_1^{\alpha_1} \cdots p_M^{\alpha_M} q_1^{\beta_1} \cdots q_n^{\beta_n}$, with $p_1^{\alpha_1}, \dots, p_M^{\alpha_M} \in S_{A_1}$ and $q_1^{\beta_1}, \dots, q_n^{\beta_n} \in S_{A_2}$. We have

$$p_1^{\alpha_1} \cdots p_M^{\alpha_M} q_1^{\beta_1} \cdots q_n^{\beta_n} \mid n_1^M n_2^n n_3^{M+N},$$

Table 3.3: All possible \tilde{V}_1 and \tilde{V}_2 for non-Hajós values of $n \leq 180$.

n	p_1	n_1	p_2	n_2	n_3	L	$\#K$	$\#B$	$U_1 \oplus n_3 n_1 \tilde{V}_2$	$U_2 \oplus n_3 n_2 \tilde{V}_1$
72	3	3	2	2	2	{0}	0	6	$36\mathbb{I}_2 \oplus 6\mathbb{I}_3$	$24\mathbb{I}_3 \oplus 4\mathbb{I}_2$
108	3	3	2	2	3	{0}	0	252	$54\mathbb{I}_2 \oplus 9\mathbb{I}_3$	$36\mathbb{I}_3 \oplus 6\mathbb{I}_2$
120	3	5	2	2	2	{0}	0	20	$60\mathbb{I}_2 \oplus 10\mathbb{I}_3$	$40\mathbb{I}_3 \oplus 4\mathbb{I}_2$ $40\mathbb{I}_3 \oplus 4\{0, 3\}$
	5	3	2	2	2	{0}	0	18	$60\mathbb{I}_2 \oplus 6\mathbb{I}_5$ $60\mathbb{I}_2 \oplus 6\{0, 2, 3, 4, 6\}$ $60\mathbb{I}_2 \oplus 6\{0, 1, 3, 4, 7\}$	$24\mathbb{I}_5 \oplus 4\mathbb{I}_2$
144	3	3	2	2	4	{0} {0, 1}	0 2	8640 6	$72\mathbb{I}_2 \oplus 12\mathbb{I}_3$	$48\mathbb{I}_3 \oplus 8\mathbb{I}_2$
	3	3	2	4	2	{0}	0	60	$72\mathbb{I}_2 \oplus 6\mathbb{I}_3$ $72\mathbb{I}_2 \oplus 6\{0, 2, 4\}$ $72\mathbb{I}_2 \oplus 6\{0, 1, 5\}$ $72\mathbb{I}_2 \oplus 6\{0, 4, 5\}$ $72\mathbb{I}_2 \oplus 6\{0, 2, 7\}$	$48\mathbb{I}_3 \oplus 8\mathbb{I}_2$
	3	3	4	2	2	{0}	0	36	$36\mathbb{I}_4 \oplus 6\mathbb{I}_3$	$48\mathbb{I}_3 \oplus 4\mathbb{I}_4$ $48\mathbb{I}_3 \oplus 4\{0, 2, 3, 5\}$ $48\mathbb{I}_3 \oplus 4\{0, 1, 3, 6\}$ $48\mathbb{I}_3 \oplus 4\{0, 3, 5, 6\}$ $48\mathbb{I}_3 \oplus 4\{0, 1, 2, 7\}$ $48\mathbb{I}_3 \oplus 4\{0, 2, 5, 7\}$
168	3	7	2	2	2	{0}	0	42	$84\mathbb{I}_2 \oplus 14\mathbb{I}_3$	$56\mathbb{I}_3 \oplus 4\mathbb{I}_2$ $56\mathbb{I}_3 \oplus 4\{0, 3\}$ $56\mathbb{I}_3 \oplus 4\{0, 5\}$
	7	3	2	2	2	{0}	0	54	$84\mathbb{I}_2 \oplus 6\mathbb{I}_7$ $84\mathbb{I}_2 \oplus 6\{0, 2, 3, 4, 5, 6, 8\}$ $84\mathbb{I}_2 \oplus 6\{0, 1, 3, 4, 5, 6, 9\}$ $84\mathbb{I}_2 \oplus 6\{0, 3, 4, 5, 6, 8, 9\}$ $84\mathbb{I}_2 \oplus 6\{0, 1, 2, 4, 5, 6, 10\}$ $84\mathbb{I}_2 \oplus 6\{0, 2, 4, 5, 6, 8, 10\}$ $84\mathbb{I}_2 \oplus 6\{0, 1, 4, 5, 6, 9, 10\}$ $84\mathbb{I}_2 \oplus 6\{0, 2, 3, 5, 6, 8, 11\}$ $84\mathbb{I}_2 \oplus 6\{0, 1, 3, 5, 6, 9, 11\}$	$24\mathbb{I}_7 \oplus 4\mathbb{I}_2$
180	3	3	2	5	2	{0}	0	120	$90\mathbb{I}_2 \oplus 6\mathbb{I}_3$ $90\mathbb{I}_2 \oplus 6\{0, 2, 4\}$ $90\mathbb{I}_2 \oplus 6\{0, 1, 5\}$ $90\mathbb{I}_2 \oplus 6\{0, 4, 5\}$ $90\mathbb{I}_2 \oplus 6\{0, 2, 7\}$ $90\mathbb{I}_2 \oplus 6\{0, 5, 7\}$ $90\mathbb{I}_2 \oplus 6\{0, 1, 8\}$ $90\mathbb{I}_2 \oplus 6\{0, 4, 8\}$	$60\mathbb{I}_3 \oplus 10\mathbb{I}_2$
	3	3	5	2	2	{0}	0	96	$36\mathbb{I}_5 \oplus 6\mathbb{I}_3$	$60\mathbb{I}_3 \oplus 4\mathbb{I}_5$ $60\mathbb{I}_3 \oplus 4\{0, 2, 3, 4, 6\}$ $60\mathbb{I}_3 \oplus 4\{0, 1, 3, 4, 7\}$ $60\mathbb{I}_3 \oplus 4\{0, 3, 4, 6, 7\}$ $60\mathbb{I}_3 \oplus 4\{0, 1, 2, 4, 8\}$ $60\mathbb{I}_3 \oplus 4\{0, 2, 4, 6, 8\}$ $60\mathbb{I}_3 \oplus 4\{0, 1, 4, 7, 8\}$ $60\mathbb{I}_3 \oplus 4\{0, 4, 6, 7, 8\}$ $60\mathbb{I}_3 \oplus 4\{0, 1, 2, 3, 9\}$ $60\mathbb{I}_3 \oplus 4\{0, 2, 3, 6, 9\}$ $60\mathbb{I}_3 \oplus 4\{0, 1, 3, 7, 9\}$ $60\mathbb{I}_3 \oplus 4\{0, 3, 6, 7, 9\}$ $60\mathbb{I}_3 \oplus 4\{0, 1, 2, 8, 9\}$ $60\mathbb{I}_3 \oplus 4\{0, 2, 6, 8, 9\}$ $60\mathbb{I}_3 \oplus 4\{0, 3, 4, 7, 11\}$ $60\mathbb{I}_3 \oplus 4\{0, 2, 4, 8, 11\}$
	3	5	2	2	3	{0}	0	1800	$90\mathbb{I}_2 \oplus 15\mathbb{I}_3$	$60\mathbb{I}_3 \oplus 6\mathbb{I}_2$ $60\mathbb{I}_3 \oplus 6\{0, 3\}$
	5	3	2	2	3	{0}	0	2052	$90\mathbb{I}_2 \oplus 9\mathbb{I}_5$ $90\mathbb{I}_2 \oplus 9\{0, 2, 3, 4, 6\}$ $90\mathbb{I}_2 \oplus 9\{0, 1, 3, 4, 7\}$	$36\mathbb{I}_5 \oplus 6\mathbb{I}_2$
	3	3	2	2	5	{0}	0	281232	$90\mathbb{I}_2 \oplus 15\mathbb{I}_3$	$60\mathbb{I}_3 \oplus 10\mathbb{I}_2$

Table 3.4: Number of extended Vuza rhythms for non-Hajós values of $n \leq 216$.

n	p_1	n_1	p_2	n_2	n_3	L	$\#K$	$\#A$			$\#B$					
								(3)	(9)	(10)	(3)	(6)	(7)	(8)	(9)	
Theorem:								(3)	(9)	(10)	(3)	(6)	(7)	(8)	(9)	
72	2	2	3	3	2	{0}	1	3	0	0	6	0	0	0	0	
108	2	2	3	3	3	{0}	1	3	0	0	180	0	72	0	0	
120	2	2	3	5	2	{0}	1	16	0	0	20	0	0	0	0	
	2	2	5	3	2	{0}	1	8	0	0	18	0	0	0	0	
144	2	2	3	3	4	{0}	1	3	0	0	2808	1944	3888	0	0	
	2	2	3	3	4	{0, 1}	2	0	312	0	0	0	0	0	0	6
	2	2	3	3	4	{0, 9}	2	0	0	12	0	0	0	0	6	
	2	2	3	3	4	{0, 2}	4	0	156	0	0	0	0	0	0	12
	2	4	3	3	2	{0}	1	6	0	0	12	0	0	48	0	
4	2	3	3	2	{0}	1	6	0	0	6	0	0	0	30	0	
168	2	2	3	7	2	{0}	1	104	0	0	14	0	0	28	0	
	2	2	7	3	2	{0}	1	16	0	0	6	0	0	48	0	
180	2	5	3	3	2	{0}	1	9	0	0	15	0	0	105	0	
	5	2	3	3	2	{0}	1	6	0	0	6	0	0	90	0	
	3	5	2	2	3	{0}	1	16	0	0	500	0	200	1100	0	
	5	3	2	2	3	{0}	1	8	0	0	252	0	72	1728	0	
	2	2	3	3	5	{0}	1	3	0	0	45360	77760	158112	0	0	
200	2	2	5	5	2	{0}	1	125	0	0	10	0	0	50	0	
216	2	4	3	3	3	{0}	1	6	0	0	180 + 540	72 + 216	0	12672	0	
	2	2	3	3	6	{0, 3}	8	0	156	0	0	0	0	0	0	180 + 540 + 72 + 216
	2	2	3	3	6	{0, 1}	2	0	324	0	0	0	0	0	0	180 + 72
	2	2	3	3	6	{0}	1	3	0	0	754272	2449440	5832000	0	0	
	2	2	3	3	6	{0, 1, 2}	3	0	34992	0	0	0	0	0	0	6
	2	2	3	3	6	{0, 2, 4}	9	0	10935	0	0	0	0	0	0	6 + 12
	2	2	3	9	2	{0}	1	729	0	0	6 + 12	0	0	54	0	
	2	2	9	3	2	{0}	1	27	0	0	6	0	0	162	0	
4	2	3	3	3	{0}	1	6	0	0	252	0	72	5940	0		

In each column only the rhythms that can be generated by the corresponding theorem, but not by previous ones are counted. Grey numbers correspond to rhythms that can be generated also by the choice of parameters in the previous line. When there is no column (e.g., $\#A$ for Theorem 6) all the possible rhythms already appear in previous columns.

Table 3.5: Number of extended Vuza rhythms for non-Hajós values of $240 \leq n \leq 280$.

n	p_1	n_1	p_2	n_2	n_3	L	$\#K$	$\#A$			$\#B$				
								(3)	(9)	(10)	(3)	(6)	(7)	(8)	(9)
240	2	4	3	5	2	{0}	1	32	0	0	20	0	0	20 + 160	0
	2	2	3	5	4	{0, 6}	4	0	0	588	0	0	0	0	20 + 20
	2	2	3	5	4	{0, 2}	4	0	7252	0	0	0	0	0	20 + 20
	2	2	3	5	4	{0, 15}	2	0	0	64	0	0	0	0	20
	2	2	3	5	4	{0, 3}	2	0	1176	0	0	0	0	0	20
	2	2	3	5	4	{0, 1}	2	0	14504	0	0	0	0	0	20
	2	2	3	5	4	{0}	1	16	0	0	13000	9000	18000	94000	0
	2	2	5	3	4	{0}	1	8	0	0	6264	3240	5184	197856	0
	2	2	5	3	4	{0, 1}	2	0	4016	0	0	0	0	0	18
	2	2	5	3	4	{0, 5}	2	0	0	112	0	0	0	0	18
	2	2	5	3	4	{0, 15}	2	0	0	32	0	0	0	0	18
	2	2	5	3	4	{0, 2}	4	0	2008	0	0	0	0	0	12 + 24
	2	2	5	3	4	{0, 10}	4	0	0	56	0	0	0	0	12 + 24
	2	4	5	3	2	{0}	1	16	0	0	12	0	0	24 + 576	0
4	2	3	5	2	{0}	1	32	0	0	10	0	0	290	0	
4	2	5	3	2	{0}	1	16	0	0	6	0	0	102	0	
252	2	7	3	3	2	{0}	1	27	0	0	21	0	0	315	0
	7	2	3	3	2	{0}	1	9	0	0	6	0	0	618	0
	3	7	2	2	3	{0}	1	104	0	0	980	0	392	5096	0
	7	3	2	2	3	{0}	1	16	0	0	324	0	72	21312	0
	2	2	3	3	7	{0}	1	3	0	0	12830400	71383680	206126208	0	0
264	2	2	3	11	2	{0}	1	5368	0	0	22	0	0	88	0
	2	2	11	3	2	{0}	1	40	0	0	6	0	0	552	0
270	3	3	2	5	3	{0}	1	9	0	0	1125	0	450	48825	0
	3	3	5	2	3	{0}	1	6	0	0	288	0	72	48600	0
280	2	2	5	7	2	{0}	1	2232	0	0	14	0	0	112	0
	2	2	7	5	2	{0}	1	480	0	0	10	0	0	170	0

In each column only the rhythms that can be generated by the corresponding theorem, but not by previous ones are counted. Grey numbers correspond to rhythms that can be generated also by the choice of parameters in the previous line. When there is no column (e.g., $\#A$ for Theorem 6) all the possible rhythms already appear in previous columns.

and since $(n_1, n_2) = 1$ and $p_i^{\alpha_i} \nmid n_3$ and $q_j^{\beta_j} \nmid n_3$, we can conclude

$$p_1^{\alpha_1} \cdots p_M^{\alpha_M} q_1^{\beta_1} \cdots q_n^{\beta_n} \mid n_1 n_2 n_3.$$

Moreover, since

$$p_1^{\alpha_1} \cdots p_M^{\alpha_M} \nmid n_3 p_2 n_2 \quad \text{and} \quad q_1^{\beta_1} \cdots q_n^{\beta_n} \nmid n_3 p_1 n_1$$

it follows that

$$p_1^{\alpha_1} \cdots p_M^{\alpha_M} q_1^{\beta_1} \cdots q_n^{\beta_n} \nmid n_3 p_2 n_2 \quad \text{and} \quad p_1^{\alpha_1} \cdots p_j^{\alpha_j} q_1^{\beta_1} \cdots q_k^{\beta_k} \nmid n_3 p_1 n_1.$$

This means that

$$p_1^{\alpha_1} \cdots p_M^{\alpha_M} q_1^{\beta_1} \cdots q_n^{\beta_n} \in R_{A_1} \cap R_{A_2}.$$

Considering, instead, any product of prime powers $p_1^{\alpha_1} \cdots p_M^{\alpha_M}$ (resp. $q_1^{\beta_1} \cdots q_n^{\beta_n}$) belonging exclusively to S_{A_1} (resp. S_{A_2}), we obtain:

$$p_1^{\alpha_1} \cdots p_M^{\alpha_M} \mid n_1 n_3 \quad (\text{resp. } q_1^{\beta_1} \cdots q_n^{\beta_n} \mid n_2 n_3),$$

and therefore

$$p_1^{\alpha_1} \cdots p_M^{\alpha_M} \in R_{A_1} \quad (\text{resp. } q_1^{\beta_1} \cdots q_n^{\beta_n} \in R_{A_2}).$$

In both cases, those products are elements of $R_{A_1} \cup R_{A_2}$, and so $A(x)$ satisfies (T2) condition. □

Example 13. Let us consider the following Vuza canon with period $n = 9000$:

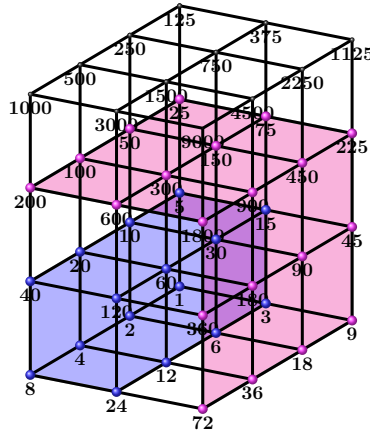

$$A_1 = (2^3 \cdot 3 \cdot 5) \mathbb{I}_{3,5}$$

$$S_{A_1} = \{9, 25\}$$

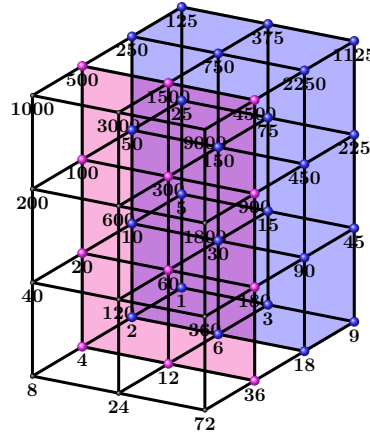

$$A_2 = (2 \cdot 3^2 \cdot 5^3) \mathbb{I}_2$$

$$S_{A_2} = \{4\}$$

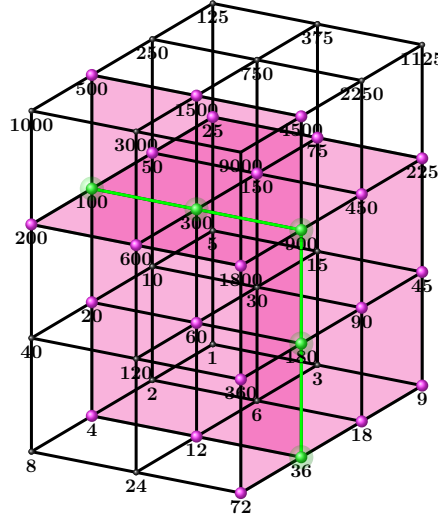

$$A = A_1 \oplus A_2$$

$$S_{A=A_1 \oplus A_2} = \{4, 9, 25\}$$

$$R_{A_1} \cap R_{A_2} = \{36, 100, 180, 300, 900\}$$

3.5 Operations on aperiodic canons

In this section we describe some known techniques for the construction of tiling rhythmic canons starting from aperiodic tiling rhythmic canons. We show that these operations preserve condition (T2) in the following sense.

Let us say that the canon $A \oplus B = \mathbb{Z}_n$ verifies condition (T2) if at least one of the rhythms A and B verifies it.

We illustrate the central role of the Vuza canons in this type of constructions and finally, we introduce new operations on tiling rhythmic canons based on their cyclotomic factorisation.

Given a rhythmic canon, there are many ways to generate new canons, used (and often devised) by the composers themselves. Let us see the mathematical interpretation of such manipulations.

3.5.1 Duality

We observed in Chapter 2 that the commutative property of the addition in the cyclic group \mathbb{Z}_n makes the definition of rhythmic canon symmetrical in the inner and outer rhythms. Then, the simplest transformation we can apply to a canon is the interchange between inner and outer rhythm.

Definition 15 (duality). Given a tiling rhythmic canon $\mathbb{Z}_n = A \oplus B$, the canon $\mathbb{Z}_n = B \oplus A$ is said to be obtained from the first by *duality*.

3.5.2 k -stuttering (and multiplexing) and k -zooming

Zooming and *stuttering* are two dual transformations: starting from a canon $A \oplus B = \mathbb{Z}_n$, one gets a new canon obtained by replacing each note or rest in the inner voice A by k repetitions of itself, and by stretching by factor k the entries of the outer voice B .

Definition 16 (k -stuttering). Let $A \oplus B = \mathbb{Z}_n$. The k -stuttering of A is

$$\text{Stut}(A, k) = kA \oplus \{0, 1, \dots, k-1\} \in \mathbb{Z}_{k|A|}.$$

Definition 17 (k -zooming). Let $A \oplus B = \mathbb{Z}_n$. The k -zooming of B is $kB \in \mathbb{Z}_{|B|}$.

Theorem 12 (Amiot). $A \oplus B = \mathbb{Z}_n$ if and only if $\text{Stut}(A, k) \oplus kB = \mathbb{Z}_{kn}$.

The *multiplexing* transformation is a simple extension of stuttering:

Definition 18 (multiplexing). Let $A_i \oplus B = \mathbb{Z}_n$, for $i = 0, \dots, k-1$, be k canons with the same outer rhythm. The *multiplexing* of A_0, A_1, \dots, A_{k-1} is

$$\text{MPlex}(A_0, A_1, \dots, A_{k-1}) = \bigcup_{i=0}^{k-1} (i + kA_i).$$

Theorem 13 (Amiot). $A_i \oplus B = \mathbb{Z}_n$ for all $i = 0, \dots, k-1$ if and only if

$$\text{MPlex}(A_0, A_1, \dots, A_{k-1}) \oplus kB = \mathbb{Z}_{kn}.$$

We observe trivially that the rhythms of a canon always verify condition (T1) (by the Coven-Meyerowitz Theorem 1); consequently, in particular, condition (T1) is invariant under multiplexing and zooming.

Proposition 5. *The multiplexing transformation preserves condition (T2).*

These operations also preserve the aperiodicity of each voice, and hence turn a (extended) Vuza canon into a larger (extended) Vuza canon.

Note that the dual transformation, that is the multiplexing of the outer voice, is also possible.

Example 14. Let us consider the canons with period 72

$$\begin{aligned} A \oplus B &= (18\mathbb{I}_2 \oplus 8\mathbb{I}_3) \oplus ((36\mathbb{I}_2 \oplus 6\mathbb{I}_3) \sqcup (24\mathbb{I}_3 \oplus 4\mathbb{I}_2 \oplus \{1\})) = \\ &= \{0, 8, 16, 18, 26, 34\} \oplus \{0, 1, 5, 6, 12, 25, 29, 36, 42, 48, 49, 53\}, \end{aligned}$$

whose grid representation is in Figure 3.19a, and

$$\begin{aligned} A' \oplus B &= (18\mathbb{I}_2 \oplus 8\{0, 2, 4\}) \oplus ((36\mathbb{I}_2 \oplus 6\mathbb{I}_3) \sqcup (24\mathbb{I}_3 \oplus 4\mathbb{I}_2 \oplus \{1\})) = \\ &= \{0, 16, 18, 32, 34, 50\} \oplus \{0, 1, 5, 6, 12, 25, 29, 36, 42, 48, 49, 53\}, \end{aligned}$$

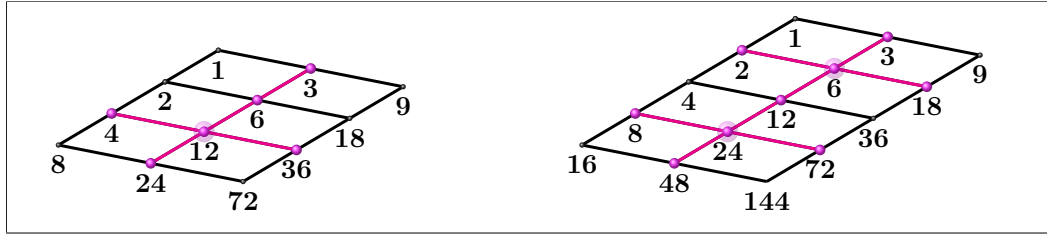
Figure 3.18: $n = 144$. $A_{CM} = 9\mathbb{I}_2 \oplus 36\mathbb{I}_2 \oplus 16\mathbb{I}_3$.

Lattice representation of the multiplexing and the 2-zooming in Example 14.

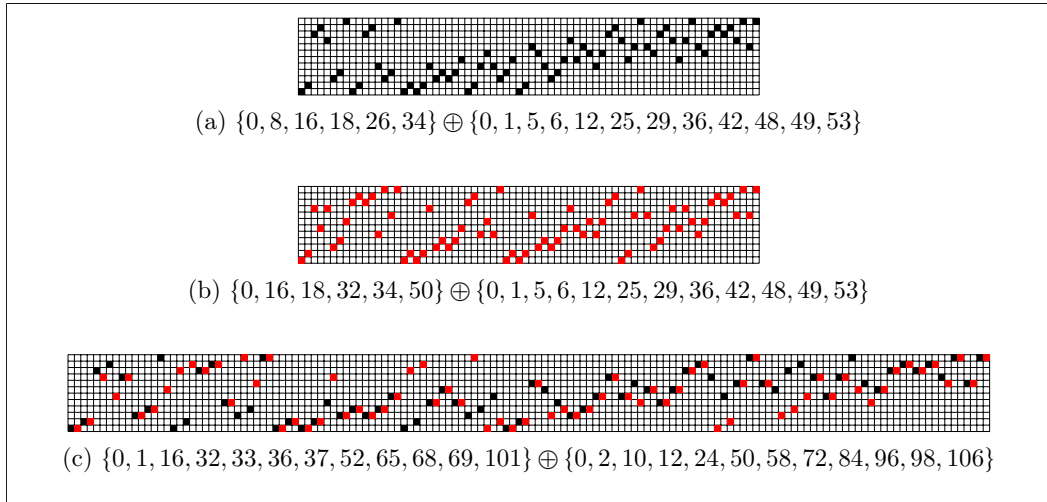
Figure 3.19: $n = 144$. Grid representation.

whose grid representation is in Figure 3.19b. The multiplexing of A and A' and the 2-zooming of B produce the following Vuza canon with period 144:

$$\begin{aligned} & ((\{0\} + 2A) \cup (\{1\} + 2A')) \oplus 2B \\ &= \{0, 1, 16, 32, 33, 36, 37, 52, 65, 68, 69, 101\} \oplus \{0, 2, 10, 12, 24, 50, 58, 72, 84, 96, 98, 106\}. \end{aligned}$$

whose lattice representation is in Figure 3.18. The segment whose prime power is not a multiple of $k = 2$ extends until it touches the final hyperplane of multiples of 16. The axis of indices of cyclotomic polynomials extending from one power of $k = 2$ instead is translated to include cyclotomic polynomials with indices $\{8, 24, 72\}$ and the edge from 2 to 18 is inserted.

3.5.3 Affine transformation

Recall Tijdeman's theorem:

Theorem 14 (Tijdeman). *If $A \oplus B = \mathbb{Z}_n$ is a rhythmic canon, then also $kA \oplus B = \mathbb{Z}_n$ for every positive integer k such that $(k, |A|) = 1$.*

As we have seen above, by Lemma 6, the sets R_{kA} and S_{kA} are exactly the same as R_A and S_A : hence (T2) and aperiodicity are true for kA whenever they are true for A .

3.5.4 k -concatenation

Definition 19 (k -concatenation). The k -concatenation of the rhythm $A \in \mathbb{Z}_n$ is the rhythm:

$$\text{Conc}(A, k) = (A \oplus \{0, n, 2n, \dots, (k-1)n\}) \in \mathbb{Z}_{kn}.$$

It is easy to see the following consequence of our previous definition:

Theorem 15 (Amiot). *$A \oplus B = \mathbb{Z}_n$ if and only if $\text{Conc}(A, k) \oplus B = \mathbb{Z}_{kn}$.*

Proof. For every $z \in \mathbb{Z}$ and for every $r = s + tk$, with $0 \leq s < k$, we have

$$z = a + b + rn \iff z = (a + sn) + b + t(kn).$$

□

Proposition 6. *Concatenation preserves condition (T2).*

Proof. We observe that

$$\{0, n, 2n, \dots, (k-1)n\}(x) = (n\mathbb{I}_k)(x) = \mathbb{I}_k(x^n) = \frac{x^{kn} - 1}{x^n - 1} = \prod_{d|kn, d \nmid n} \Phi_d(x),$$

then $R_{n\mathbb{I}_k} = \{d \mid kn \mid d \nmid n\}$ and $S_{n\mathbb{I}_k} = \{p^\alpha \mid kn \mid p^\alpha \nmid n, p \text{ prime}\}$. For each set of powers of distinct primes $p_1^{\alpha_1}, \dots, p_m^{\alpha_m} \in S_{n\mathbb{I}_k}$, $p_1^{\alpha_1} \cdots p_m^{\alpha_m} \in R_A$, i.e. $n\mathbb{I}_k$ verifies condition (T2). Since $(A \oplus \{0, n, 2n, \dots, (k-1)n\})(x) = A(x)\mathbb{I}_k(x^n)$ and cyclotomic polynomials are irreducible, we have that $R_{A \oplus n\mathbb{I}_k} = R_A \cup R_{n\mathbb{I}_k}$. We see that $A \oplus n\mathbb{I}_k$ also verifies condition (T2): if $p_1^{\alpha_1}, \dots, p_m^{\alpha_m} \in S_{A \oplus n\mathbb{I}_k}$ are powers of distinct primes, there are three possibilities:

1. $p_i^{\alpha_i} \in S_A \forall i = 1, \dots, m \implies \prod_{i=1}^m p_i^{\alpha_i} \in R_A$ because, by hypothesis, A verifies condition (T2), then $\prod_{i=1}^m p_i^{\alpha_i} \in R_{A \oplus n\mathbb{I}_k}$.
2. $p_i^{\alpha_i} \in S_{n\mathbb{I}_k} \forall i = 1, \dots, m \implies \prod_{i=1}^m p_i^{\alpha_i} \in R_{n\mathbb{I}_k}$ because, as we have seen, $n\mathbb{I}_k$ verifies condition (T2), then $\prod_{i=1}^m p_i^{\alpha_i} \in R_{A \oplus n\mathbb{I}_k}$.
3. $p_i^{\alpha_i} \in S_A \forall i = 1, \dots, h$ and $p_j^{\alpha_j} \in S_{n\mathbb{I}_k} \forall j = h+1, \dots, m$, then $\forall i, j$ we have that $p_i^{\alpha_i} \mid N$, $p_j^{\alpha_j} \mid kN$ and $p_j^{\alpha_j} \nmid N$, therefore, since we are dealing with powers of distinct primes, $\prod_{i=1}^m p_i^{\alpha_i} = p_i^{\alpha_i} \mid kN$ and $\nmid N$, that is $\prod_{i=1}^m p_i^{\alpha_i} \in R_{nkA} \subset R_{A \oplus n\mathbb{I}_k}$.

Figure 3.20: $n = 360$. Grid representation.

Figure 3.21: $n = 360$. $A_{CM} = 90\mathbb{I}_2 \oplus 40\mathbb{I}_3$.



Lattice representation of the multiplexing and the 5-zooming in Figure 3.20.

Figure 3.22: $n = 144$. $A_{CM} = 18\mathbb{I}_2 \oplus 72\mathbb{I}_2 \oplus 16\mathbb{I}_3$.

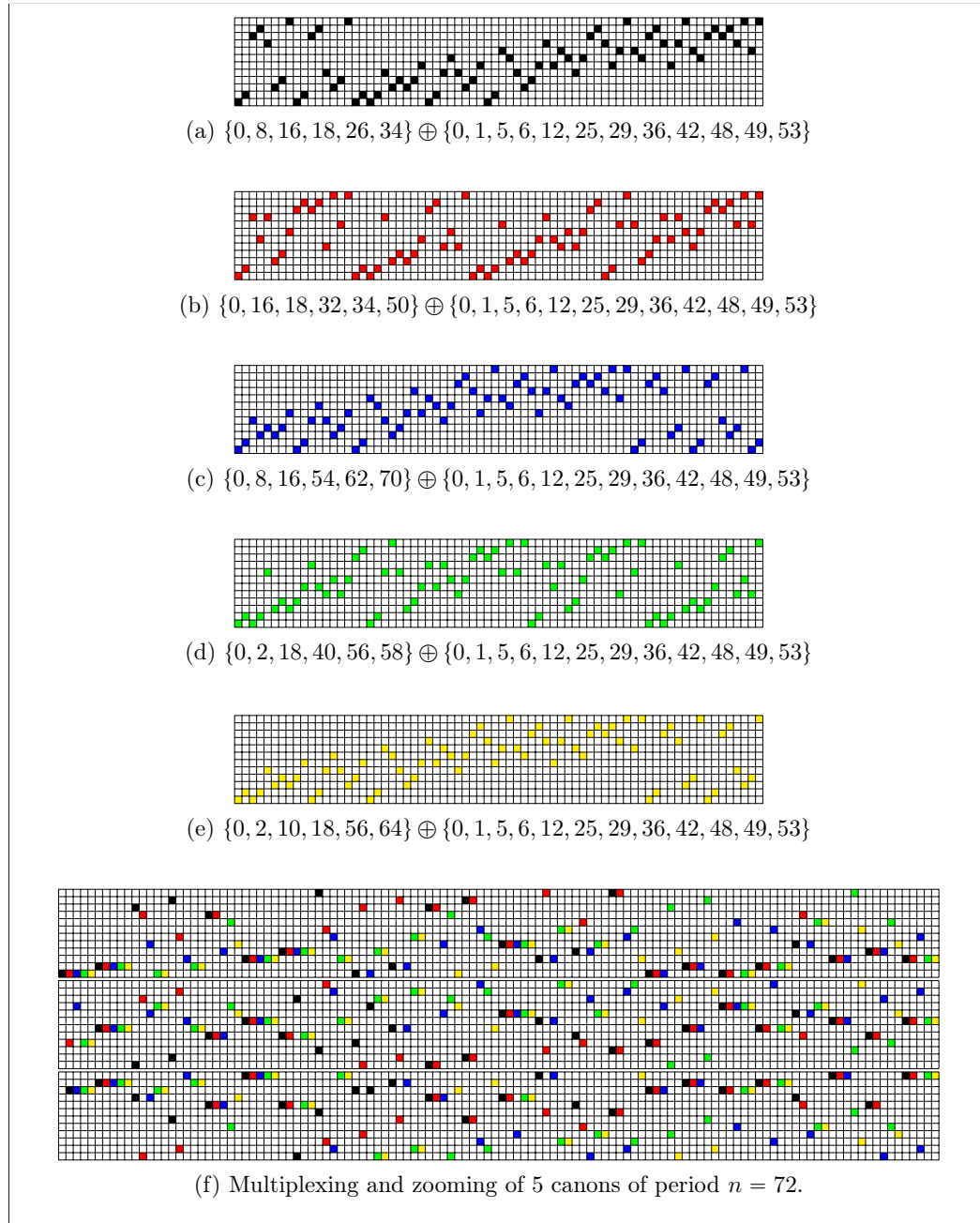
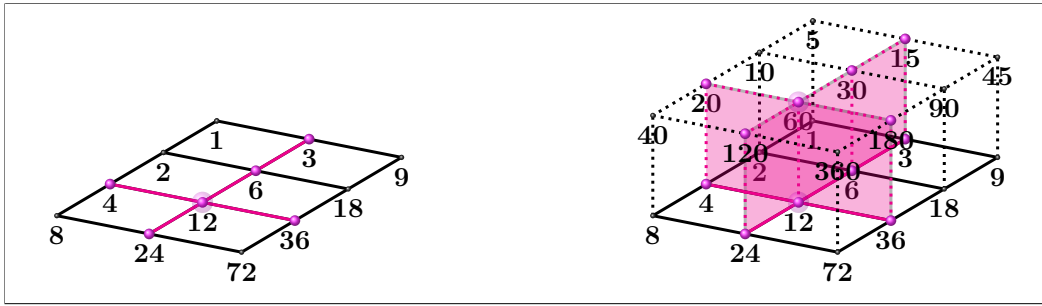
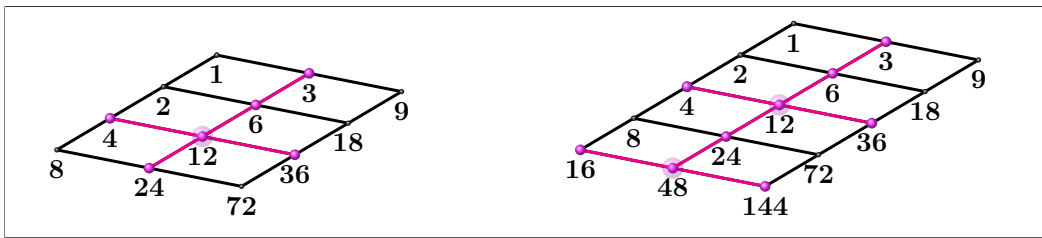

Lattice representation of the concatenation in Example 15.

□

Concatenation replaces the rhythm by several copies of itself. It is therefore obvious that the resulting rhythm is periodic.

Example 15. Let us go back to Example 14 and consider the inner rhythm $A = \{0, 8, 16, 18, 26, 34\}$. The 2-concatenation of $A \subset \mathbb{Z}_{72}$ is

$$A \oplus \{0, 72\} = \{0, 8, 16, 18, 26, 34, 72, 80, 88, 90, 98, 106\}.$$

The lattice representation of the canon $\text{Conc}(A, 2) \oplus B = \mathbb{Z}_{144}$ is given in Figure 3.22. We see that the new canon $\text{Conc}(A, 2) \oplus B = \mathbb{Z}_{144}$ is periodic modulo 72: all the indices of the maximal hyperplane 16-48-144 are in $R_{\text{Conc}(A,2)}$.

Let us remark that a Vuza canon is precisely a canon that cannot be produced by concatenation of some smaller canon. In particular,

Proposition 7 (Amiot). *Every tiling rhythmic canon can be produced by concatenation and duality from either the trivial canon $\{0\} \oplus \{0\} = \{0\}$ or a Vuza canon.*

3.5.5 Uplifting

Proposition 8 (Amiot). *If A tiles \mathbb{Z}_n then A tiles any larger cyclic overgroup \mathbb{Z}_{kn} ; moreover, translating any element of A by any multiple of n provides a motif that also tiles \mathbb{Z}_{kn} .*

Proof. If

$$A \oplus B = \{a_0, \dots, a_{p-1}\} \oplus \{b_0, \dots, b_{q-1}\} = \mathbb{Z}_n,$$

let $\tilde{A} = \{a_0 + k_0n, \dots, a_{p-1} + k_{p-1}n\} \subset \mathbb{Z}_{kn}$ and $\tilde{B} = \{b_i + \kappa n\}$, with $\kappa = 0, \dots, k-1$. Then $\tilde{A} \oplus \tilde{B} = \mathbb{Z}_{kn}$ since the mapping $\tilde{A} \oplus \tilde{B} \ni (a, b) \mapsto a + b$ is still injective and $|\tilde{A}||\tilde{B}| = kN$. \square

Example 16. Once again, let us look at the effects of this transformation to our canon of reference in Example 14. Starting with the canon

$$A \oplus B = \{0, 8, 16, 18, 26, 34\} \oplus \{0, 1, 5, 6, 12, 25, 29, 36, 42, 48, 49, 53\},$$

one can produce

$$\{0, 16, 18, 26, 34, 80 = 8 + 72\} \oplus (B \sqcup B + 1 \cdot 72) = \mathbb{Z}_{144}$$

Let us now see how Vuza canons become fundamental for the study of rhythmic canons.

Theorem 16 (Amiot). *Every rhythmic canon can be reduced to trivial canon $\{0\} \oplus \{0\} = \{0\}$ or a Vuza canon.*

Corollary 1. *If a rhythmic canon does not satisfy the condition (T2) it is possible to collapse it to a Vuza canon that does not satisfy the condition (T2).*

The problem of the need for condition (T2) is reduced to the investigation of the canons of Vuza.

3.5.6 Operations on extended Vuza canons

The following operations naturally follow from the definition of extended Vuza canon. Recall that an extended Vuza canon is characterised by the following sets: A_1, A_2, V_1, V_2 . Whenever we replace the sets A_1, A_2, V_1, V_2 with A'_1, A'_2, V'_1 and V'_2 , we get new extended Vuza canons, as proved in Theorems 7, 8, 9 and 10.

Starting from a Vuza canon, or an extended Vuza canon, it is possible to consider different choices of the parameters p_1, n_1, p_2, n_2 , and n_3 and of the sets $\tilde{A}_1, \tilde{A}_2, \tilde{V}_1, \tilde{V}_2, W, \bar{L}$, and K on the basis of the theorem seen in the previous section to produce new extended Vuza canons.

In this section we see, starting from a Vuza canon (or extended Vuza canon) the lattices of the new canon change according to the different choice of parameters and characteristic sets. Let us see the classical example of \mathbb{Z}_{72} . When \bar{n}_1 is a multiple of n_1 we can recognise some precise changes in the lattices of the canons. We are dealing with extended Vuza canons, so we consider the following hypothesis. Let $n = p_1n_1p_2n_2n_3 \in \mathbb{N}$ such that:

1. $p_1, n_1, p_2, n_2, n_3 > 1$;
2. $\gcd(p_1 n_1, p_2 n_2) = 1$;
3. if n_3 is not prime, there is no prime q such that $q \mid n_3$, but $q \nmid p_1 n_1 p_2 n_2$.

Let H be the subgroup $H = n_3 \mathbb{I}_{p_1 n_1 p_2 n_2}$ of \mathbb{Z}_n with $n = p_1 n_1 p_2 n_2 n_3$, K be a complete set of cosets representatives for \mathbb{Z}_n modulo H such that K is the disjoint union $K = K_1 \sqcup K_2 \sqcup K_3$ with $K_1, K_2 \neq \emptyset$, and $W = n_3 n_1 n_2 \mathbb{I}_{p_1 p_2}$. Take

- \tilde{A}_1 as a complete aperiodic set of coset representatives for $\mathbb{Z}_{p_2 n_2}$ modulo $n_2 \mathbb{I}_{p_2}$;
- \tilde{A}_2 as a complete aperiodic set of coset representatives for $\mathbb{Z}_{p_1 n_1}$ modulo $n_1 \mathbb{I}_{p_1}$;
- $\tilde{V}_1^1, \dots, \tilde{V}_1^j$ as complete aperiodic sets of coset representatives for $\mathbb{Z}_{p_2 n_1}$ modulo $p_2 \mathbb{I}_{n_1}$;
- $\tilde{V}_2^1, \dots, \tilde{V}_2^h$ as complete aperiodic sets of coset representatives for $\mathbb{Z}_{p_1 n_2}$ modulo $p_1 \mathbb{I}_{n_2}$.

Let $A \oplus B$ be a (extended) Vuza canon, with

$$\begin{aligned}
 A &= n_3 p_1 n_1 \tilde{A}_1 \oplus n_3 p_2 n_2 \tilde{A}_2 \oplus \bar{L} \\
 B &= \left(\left(U_1 \oplus n_3 n_1 \tilde{V}_2^1 \oplus \{k_1^1, \dots, k_1^{l_1}\} \right) \sqcup \dots \right. \\
 &\quad \left. \dots \sqcup \left(U_1 \oplus n_3 n_1 \tilde{V}_2^j \oplus \{k_1^{l_j-1+1}, \dots, k_1^{|K_1|}\} \right) \right) \sqcup \\
 &\quad \left(\left(U_2 \oplus n_3 n_2 \tilde{V}_1^1 \oplus \{k_2^1, \dots, k_2^{m_1}\} \right) \sqcup \dots \right. \\
 &\quad \left. \dots \sqcup \left(U_2 \oplus n_3 n_2 \tilde{V}_1^h \oplus \{k_2^{m_h-1+1}, \dots, k_2^{|K_2|}\} \right) \right) \\
 &\quad \sqcup (n_3 n_1 n_2 \mathbb{I}_{p_1 p_2} \oplus K_3)
 \end{aligned}$$

\bar{n}_i -operation ($i = 1, 2$)

Definition 20 (\bar{n}_1 -operation). Let $A \oplus B = \mathbb{Z}_n$ be a (extended) Vuza canon and let $\bar{n}_1 = \theta n_1$, with $\theta \in \mathbb{N}^*$, such that p_1, \bar{n}_1, p_2, n_2 , and n_3 satisfy conditions 1, 2, and 3. The \bar{n}_1 -operation on $A \oplus B = \mathbb{Z}_n$ produces the new (extended) Vuza canon:

$$\text{Oper}_{\bar{n}_1}(A \oplus B) = A^{\bar{n}_1} \oplus B^{\bar{n}_1} = \mathbb{Z}_{\theta n},$$

with

$$\begin{aligned}
A^{\bar{n}_1} &= n_3 p_1 \bar{n}_1 \tilde{A}_1 \oplus n_3 p_2 n_2 \tilde{A}_2^{\bar{n}_1} \oplus \bar{L} \\
B^{\bar{n}_1} &= \left(\left(U_1^{\bar{n}_1} \oplus n_3 \bar{n}_1 \tilde{V}_2^1 \oplus \{k_1^1, \dots, k_1^{l_1}\} \right) \sqcup \dots \right. \\
&\quad \left. \dots \sqcup \left(U_1^{\bar{n}_1} \oplus n_3 \bar{n}_1 \tilde{V}_2^j \oplus \{k_1^{l_j-1+1}, \dots, k_1^{|K_1|}\} \right) \right) \sqcup \\
&\quad \left(\left(U_2^{\bar{n}_1} \oplus n_3 n_2 \tilde{V}_1^{1, \bar{n}_1} \oplus \{k_2^1, \dots, k_2^{m_1}\} \right) \sqcup \dots \right. \\
&\quad \left. \dots \sqcup \left(U_2^{\bar{n}_1} \oplus n_3 n_2 \tilde{V}_1^{h, \bar{n}_1} \oplus \{k_2^{m_{h-1}+1}, \dots, k_2^{|K_2|}\} \right) \right) \\
&\quad \sqcup (n_3 \bar{n}_1 n_2 \mathbb{I}_{p_1 p_2} \oplus K_3),
\end{aligned}$$

where

- $U_1^{\bar{n}_1} = n_3 p_1 \bar{n}_1 n_2 \mathbb{I}_{p_2}$;
- $U_2^{\bar{n}_1} = n_3 p_2 n_2 \bar{n}_1 \mathbb{I}_{p_1}$;
- $\tilde{A}_2^{\bar{n}_1}$ is a complete aperiodic set of coset representatives for $\mathbb{Z}_{p_1 \bar{n}_1}$ modulo $\bar{n}_1 \mathbb{I}_{p_1}$;
- $\tilde{V}_1^{1, \bar{n}_1}, \dots, \tilde{V}_1^{j, \bar{n}_1}$ are complete aperiodic sets of coset representatives for $\mathbb{Z}_{p_2 \bar{n}_1}$ modulo $p_2 \mathbb{I}_{\bar{n}_1}$;

The definition is completely symmetric for the \bar{n}_2 -operation.

We notice that $R_A \subset R_{A^{\bar{n}_1}}$ since, by construction (see Theorem 3), the elements of R_A are the divisors of $n_3 p_1 n_1 n_2$ which do not divide $n_3 p_1 n_1$ together with the divisors of $n_3 p_2 n_2 n_1$ which do not divide $n_3 p_2 n_2$, while the elements of $R_{A^{\bar{n}_1}}$ are the divisors of $\theta n_3 p_1 n_1 n_2$ which do not divide $\theta n_3 p_1 n_1$ together with the divisors of $\theta n_3 p_2 n_2 n_1$ which do not divide $n_3 p_2 n_2$. Also note that $S_A \subsetneq S_{A^{\bar{n}_1}}$, which implies that $|A^{\bar{n}_1}| = \theta |A|$. Instead, $S_{B^{\bar{n}_1}}$ is quite different from S_B and $S_B \not\subseteq S_{B^{\bar{n}_1}}$: the powers of primes dividing θ and greater than n_3 in S_B are multiplied by θ . As a consequence, $|B^{\bar{n}_1}| = |B|$.

In this regard, it is interesting to observe what happens to the lattices of the cyclotomic polynomials of $A \oplus B = \mathbb{Z}_n$ and $A^{\bar{n}_1} \oplus B^{\bar{n}_1} = \mathbb{Z}_{\theta n}$. Comparing them, the effect of the \bar{n}_1 -operation is the following: the edge resulting from the difference between the convex hull of $n_3 p_2 n_2 \mathbb{I}_{n_1}$ and the convex hull of the cyclotomic indices of \tilde{A}_2 appears to be expanded by factor θ along the axes of the powers of the primes that divide θ ; as for the first factor of A , on the other hand, there is an expansion by factor θ of both the edge obtained as the difference between the convex hull of $n_3 p_1 n_1 \mathbb{I}_{n_2}$ and the convex hull of the cyclotomic indices of \tilde{A}_1 , and the convex hull \tilde{A}_1 itself. Figures 3.23, 3.24, and 3.25 show three examples referring to a generic extended Vuza canon of period 72 (we have only one possible lattice of cyclotomic polynomials for extended Vuza canons of period $n = 72$) to which we applied the \bar{n}_i -operation, for $i = 1, 2$: in the first two figures, θ is a prime that already divided n (these are the $60 = 48 + 12$ rhythms B for $n = 144$ and the $72 = 6 + 12 + 54$ rhythms B for $n = 216$ analyzed in Table 3.4), while, in the last one, θ is a prime that did not divide n . Graphically, the two necessary conditions for aperiodicity in both rhythms remain satisfied: each maximal hyperplane

Figure 3.23: $n = 144$. $A_{CM} = 18\mathbb{I}_2 \oplus 36\mathbb{I}_2 \oplus 16\mathbb{I}_3$.

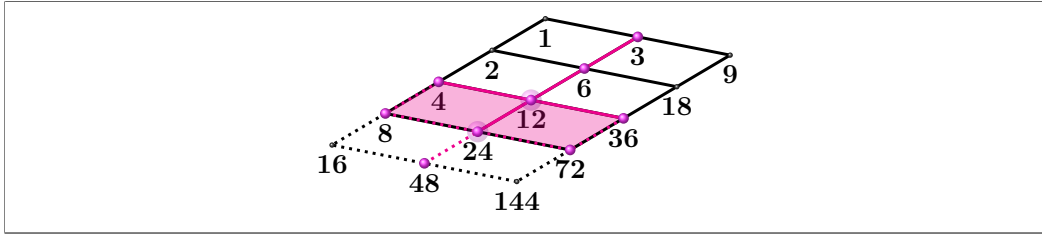

$4^{\bar{n}_1}$ -operation on a Vuza canon of order 72. The parameters become: $p_1 = 2$, $n_1 = 2 \cdot 2 = 4$, $p_2 = 3$, $n_2 = 3$, and $n_3 = 2$. $L = \{0\}$. $\#B = 60$.

Figure 3.24: $n = 216$. $A_{CM} = 54\mathbb{I}_2 \oplus 8\mathbb{I}_3 \oplus 24\mathbb{I}_3$.

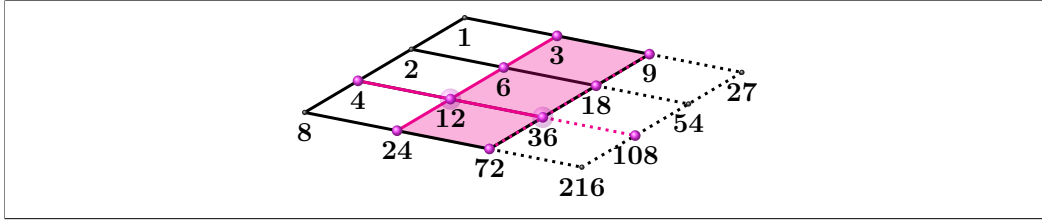

$\bar{n}_2 = 9$ -operation on a Vuza canon of order 72. The parameters become: $p_1 = 2$, $n_1 = 2$, $p_2 = 3$, $n_2 = 3 \cdot 3 = 9$, and $n_3 = 2$. $L = \{0\}$. $\#B = 72$.

of the lattice has non-null intersection with convex hulls of the cyclotomic indices of A , and the intersection is different from an entire maximal hyperplane.

\bar{n}_3 -operation

In dealing with the case of the change of parameter from n_3 to θn_3 , we need to distinguish two starting situations: Vuza canons or extended Vuza canons. The reason lies in the fact that a variation in n_3 necessarily affects a variation in the sets L and K (since $L \oplus K = \mathbb{Z}_{n_3}$), when we are treating the case of extended Vuza canons.

Therefore, we first deal with the non-extended Vuza canons.

Definition 21 (\bar{n}_3 -operation). Let $A \oplus B = \mathbb{Z}_n$ a Vuza canon and let $\bar{n}_3 = \theta n_3$, with $\theta \in \mathbb{N}^*$, such that p_1 , n_1 , p_2 , n_2 , and \bar{n}_3 satisfy conditions 1, 2, and 3. Let also $H^{\bar{n}_3}$ be the subgroup $H^{\bar{n}_3} = \bar{n}_3 \mathbb{I}_{p_1 n_1 p_2 n_2}$ of $\mathbb{Z}_{\theta n}$ and $K^{\bar{n}_3} = K_1^{\bar{n}_3} \sqcup K_2^{\bar{n}_3} \sqcup K_3^{\bar{n}_3}$ (with $K_1^{\bar{n}_3}, K_2^{\bar{n}_3} \neq \emptyset$) be a complete set of cosets representatives for $\mathbb{Z}_{\theta n}$ modulo $H^{\bar{n}_3}$. The \bar{n}_3 -operation on $A \oplus B = \mathbb{Z}_n$ produces the new Vuza canon:

$$\text{Oper}_{\bar{n}_3}(A \oplus B) = A^{\bar{n}_3} \oplus B^{\bar{n}_3} = \mathbb{Z}_{\theta n},$$

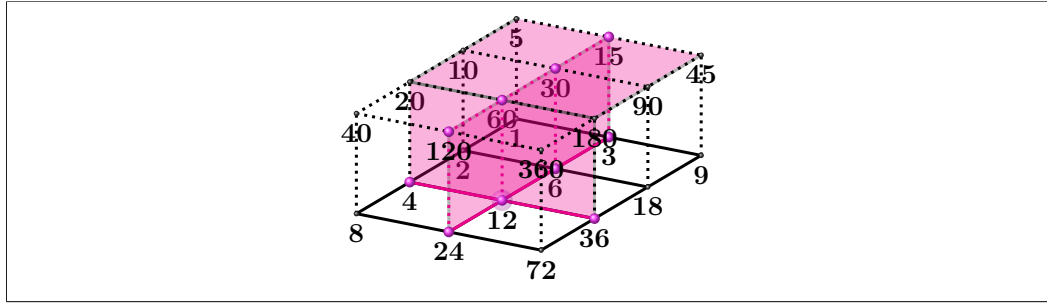
Figure 3.25: $n = 360$. $A = 18\mathbb{I}_6 \oplus 40\mathbb{I}_2$.

$\bar{n}_1 = 10$ -operation on a Vuza canon of order 72. The parameters become: $p_1 = 2$, $\mathbf{n}_1 = \mathbf{2} \cdot \mathbf{5}$, $p_2 = 3$, $n_2 = 3$, and $n_3 = 2$. $L = \{0\}$. $\#B = 990$.

with

$$\begin{aligned}
 A^{\bar{n}_3} &= \bar{n}_3 p_1 n_1 \tilde{A}_1 \oplus \bar{n}_3 p_2 n_2 \tilde{A}_2 \\
 B^{\bar{n}_3} &= \left(\left(U_1^{\bar{n}_3} \oplus \bar{n}_3 n_1 \tilde{V}_2^1 \oplus \left\{ k_{1,\bar{n}_3}^1, \dots, k_{1,\bar{n}_3}^{u_1} \right\} \right) \sqcup \dots \right. \\
 &\quad \left. \dots \sqcup \left(U_1^{\bar{n}_3} \oplus \bar{n}_3 n_1 \tilde{V}_2^j \oplus \left\{ k_{1,\bar{n}_3}^{u_{j-1}+1}, \dots, k_{1,\bar{n}_3}^{|K_1^{\bar{n}_3}|} \right\} \right) \right) \sqcup \\
 &\quad \left(\left(U_2^{\bar{n}_3} \oplus \bar{n}_3 n_2 \tilde{V}_1^1 \oplus \left\{ k_{2,\bar{n}_3}^1, \dots, k_{2,\bar{n}_3}^{v_1} \right\} \right) \sqcup \dots \right. \\
 &\quad \left. \dots \sqcup \left(U_2^{\bar{n}_3} \oplus \bar{n}_3 n_2 \tilde{V}_1^h \oplus \left\{ k_{2,\bar{n}_3}^{v_{h-1}+1}, \dots, k_{2,\bar{n}_3}^{|K_2^{\bar{n}_3}|} \right\} \right) \right) \\
 &\quad \sqcup \left(\bar{n}_3 n_1 n_2 \mathbb{I}_{p_1 p_2} \oplus K_3^{\bar{n}_3} \right),
 \end{aligned}$$

where

- $U_1^{\bar{n}_3} = \bar{n}_3 p_1 n_1 n_2 \mathbb{I}_{p_2}$;
- $U_2^{\bar{n}_3} = \bar{n}_3 p_2 n_2 n_1 \mathbb{I}_{p_1}$;
- $K_1^{\bar{n}_3} = K_{1,\bar{n}_3}^1 \sqcup \dots \sqcup K_{1,\bar{n}_3}^{j_{\bar{n}_3}}$, with $K_{1,\bar{n}_3}^r = \left\{ k_{1,\bar{n}_3}^{x_{r-1}+1}, \dots, k_{1,\bar{n}_3}^{x_r} \right\}$ are non-empty subsets of $K_1^{\bar{n}_3}$;
- $K_2^{\bar{n}_3} = K_{2,\bar{n}_3}^1 \sqcup \dots \sqcup K_{2,\bar{n}_3}^{h_{\bar{n}_3}}$, with $K_{2,\bar{n}_3}^s = \left\{ k_{2,\bar{n}_3}^{y_{s-1}+1}, \dots, k_{2,\bar{n}_3}^{y_s} \right\}$ are non-empty subsets of $K_2^{\bar{n}_3}$.

Unlike after the application of n_i -operation with $i = 1, 2$, in this case the elements of both $R_{A^{\bar{n}_3}}$ and $R_{B^{\bar{n}_3}}$ undergo the same effect (and in fact n_3 has a symmetric role in A and B):

$$\begin{aligned}
 R_{A^{\bar{n}_3}} &= \theta R_A \cup (R_A \setminus (\theta R_A \cup \theta R_B)) \\
 R_{B^{\bar{n}_3}} &= \theta R_B \cup (R_B \setminus (\theta R_B \cup \theta R_A)).
 \end{aligned}$$

Figure 3.26: $n = 144$. $A_{CM} = 36\mathbb{I}_2 \oplus 16\mathbb{I}_3$.

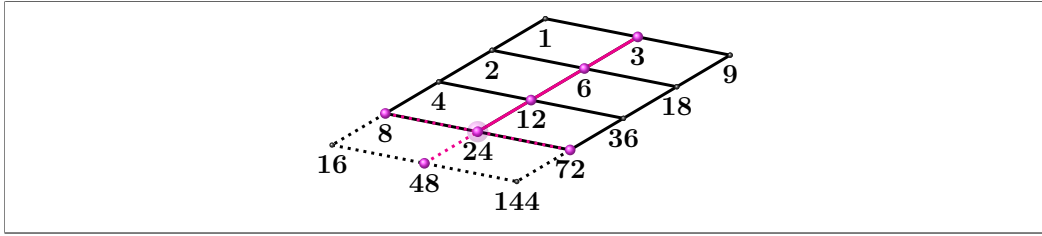

$n_3 = 4$ -operation on a Vuza canon of order 72. The parameters become: $p_1 = 2$, $n_1 = 2$, $p_2 = 3$, $n_2 = 3$, and $n_3 = 2 \cdot 2 = 4$. $L = \{0\}$. $\#B = 8640$.

Figure 3.27: $n = 216$. $A_{CM} = 54\mathbb{I}_2 \oplus 24\mathbb{I}_3$.

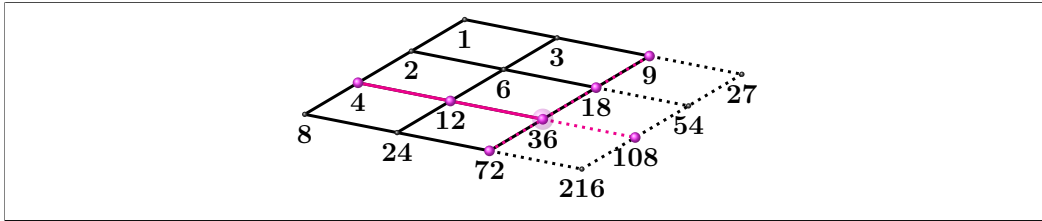

$n_3 = 6$ -operation on a Vuza canon of order 72. The parameters become: $p_1 = 2$, $n_1 = 2$, $p_2 = 3$, $n_2 = 3$, and $n_3 = 2 \cdot 3 = 6$. $L = \{0\}$. $\#B = 9035712$.

As a consequence, the cyclotomic polynomials with indices less than or equal to \bar{n}_3 are all factors of $B^{\bar{n}_3}$ just as the cyclotomic polynomials with indices less than or equal to n_3 were all factors of B . This means also that, $|B^{\bar{n}_3}| = \theta|B|$, while the cardinalities of A and $A^{\bar{n}_3}$ are the same.

Again, we are interested in giving a graphic interpretation of $R_A^{\bar{n}_3}$ and $R_B^{\bar{n}_3}$ observing what happens to the lattices of the cyclotomic polynomials of $A \oplus B = \mathbb{Z}_n$ and $A_{\bar{n}_3} \oplus B_{\bar{n}_3} = \mathbb{Z}_{\theta n}$. The \bar{n}_3 -operation determines an expansion by factor θ of both the edge obtained as the difference between the convex hull of $n_3 p_1 n_1 \mathbb{I}_{n_2}$ and the convex hull of the cyclotomic indices of \tilde{A}_1 , and the convex hull \tilde{A}_1 itself. Similarly for factor $n_3 p_2 n_2 \tilde{A}_2$ of A . Figures 3.26, 3.27, and 3.28 show three examples referring to our generic extended Vuza canon of period 72 to which we applied the \bar{n}_3 -operation: again, in the first two figures, θ is a prime that already divided n (these are the 8640 rhythms B for $n = 144$ and the 9035712 rhythms B for $n = 216$ analyzed in Table 3.4), while, in the last one, θ is a prime that did not divide n .

Let us now consider as starting canon an extended Vuza canon, whose inner rhythm A also has a factor \bar{L} .

Definition 22 (\bar{n}_3 -operation). Let $A \oplus B = \mathbb{Z}_n$ be an extended Vuza canon and let $\bar{n}_3 = \theta n_3$, with $\theta \in \mathbb{N}^*$, such that p_1 , n_1 , p_2 , n_2 , and \bar{n}_3 satisfy conditions 1, 2, and 3. Let

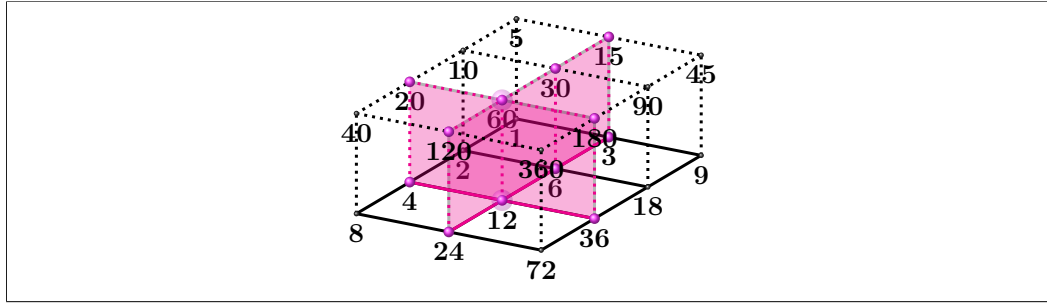
Figure 3.28: $n = 360$. $A_{CM} = 90\mathbb{I}_2 \oplus 40\mathbb{I}_3$.

$n_3 = 10$ -operation on a Vuza canon of order 72. The parameters become: $p_1 = 2$, $n_1 = 2$, $p_2 = 3$, $n_2 = 3$, and $\mathbf{n}_3 = \mathbf{2} \cdot \mathbf{5} = \mathbf{10}$. $L = \{0\}$. $\#B = 9969957367560$.

also $H^{\bar{n}_3}$ be the subgroup $H^{\bar{n}_3} = \bar{n}_3\mathbb{I}_{p_1n_1p_2n_2}$ of $\mathbb{Z}_{\theta n}$. Consider $K^{\bar{n}_3}$ as a proper subset of $\mathbb{Z}_{\bar{n}_3}$ such that $L \oplus K^{\bar{n}_3} = \mathbb{Z}_{\bar{n}_3}$ and $K^{\bar{n}_3} = K_1^{\bar{n}_3} \sqcup K_2^{\bar{n}_3} \sqcup K_3^{\bar{n}_3}$ (with $K_1^{\bar{n}_3}, K_2^{\bar{n}_3} \neq \emptyset$). The \bar{n}_3 -operation on $A \oplus B = \mathbb{Z}_n$ produces the new extended Vuza canon:

$$\text{Oper}_{\bar{n}_3}(A \oplus B) = A^{\bar{n}_3} \oplus B^{\bar{n}_3} = \mathbb{Z}_{\theta n},$$

with

$$\begin{aligned} A^{\bar{n}_3} &= \bar{n}_3 p_1 n_1 \tilde{A}_1 \oplus \bar{n}_3 p_2 n_2 \tilde{A}_2 \oplus \bar{L} \\ B^{\bar{n}_3} &= \left(\left(U_1^{\bar{n}_3} \oplus \bar{n}_3 n_1 \tilde{V}_2^1 \oplus \left\{ k_{1,\bar{n}_3}^1, \dots, k_{1,\bar{n}_3}^{u_1} \right\} \right) \sqcup \dots \right. \\ &\quad \left. \dots \sqcup \left(U_1^{\bar{n}_3} \oplus \bar{n}_3 n_1 \tilde{V}_2^j \oplus \left\{ k_{1,\bar{n}_3}^{u_{j-1}+1}, \dots, k_{1,\bar{n}_3}^{|K_1^{\bar{n}_3}|} \right\} \right) \right) \sqcup \\ &\quad \left(U_2^{\bar{n}_3} \oplus \bar{n}_3 n_2 \tilde{V}_1^1 \oplus \left\{ k_{2,\bar{n}_3}^1, \dots, k_{2,\bar{n}_3}^{v_1} \right\} \right) \sqcup \dots \\ &\quad \dots \sqcup \left(U_2^{\bar{n}_3} \oplus \bar{n}_3 n_2 \tilde{V}_1^h \oplus \left\{ k_{2,\bar{n}_3}^{v_{h-1}+1}, \dots, k_{2,\bar{n}_3}^{|K_2^{\bar{n}_3}|} \right\} \right) \\ &\quad \sqcup \left(\bar{n}_3 n_1 n_2 \mathbb{I}_{p_1 p_2} \oplus K_3^{\bar{n}_3} \right), \end{aligned}$$

where

- $U_1^{\bar{n}_3} = \bar{n}_3 p_1 n_1 n_2 \mathbb{I}_{p_2}$;
- $U_2^{\bar{n}_3} = \bar{n}_3 p_2 n_2 n_1 \mathbb{I}_{p_1}$;
- $K_1^{\bar{n}_3} = K_{1,\bar{n}_3}^1 \sqcup \dots \sqcup K_{1,\bar{n}_3}^{j_{\bar{n}_3}}$, with $K_{1,\bar{n}_3}^r = \left\{ k_{1,\bar{n}_3}^{x_{r-1}+1}, \dots, k_{1,\bar{n}_3}^{x_r} \right\}$ are non-empty subsets of $K_1^{\bar{n}_3}$;
- $K_2^{\bar{n}_3} = K_{2,\bar{n}_3}^1 \sqcup \dots \sqcup K_{2,\bar{n}_3}^{h_{\bar{n}_3}}$, with $K_{2,\bar{n}_3}^s = \left\{ k_{2,\bar{n}_3}^{y_{s-1}+1}, \dots, k_{2,\bar{n}_3}^{y_s} \right\}$ are non-empty subsets of $K_2^{\bar{n}_3}$.

Figure 3.29: $n = 288$. $A_{CM} = 36\mathbb{I}_2 \oplus 32\mathbb{I}_3$.

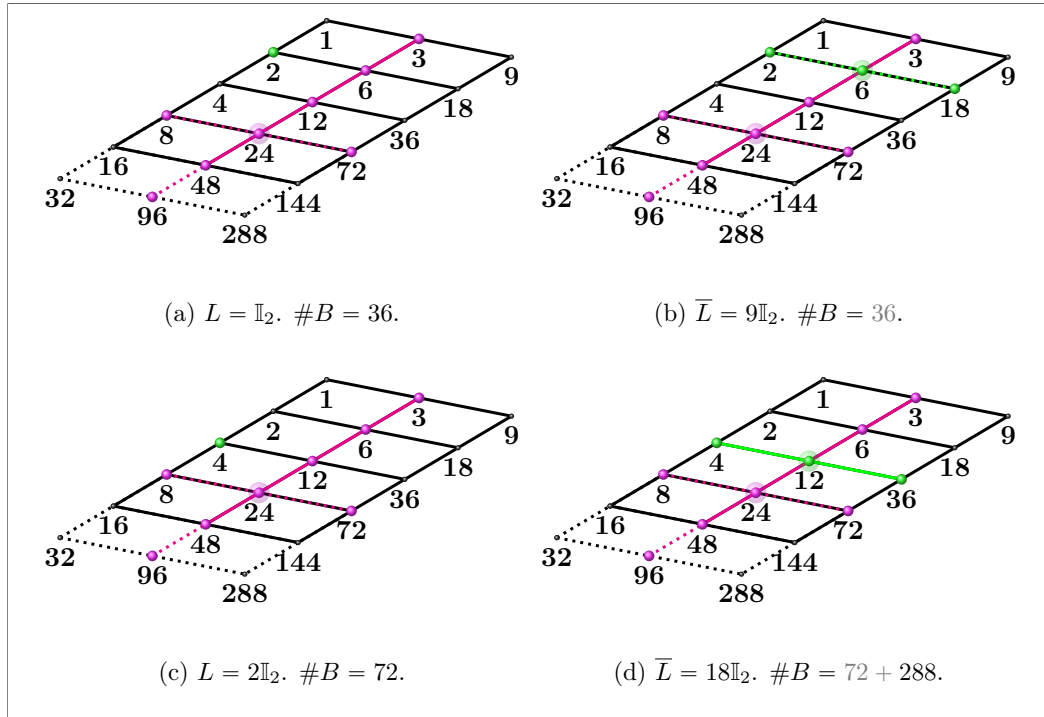

$4^{\bar{n}_3}$ -operation on an extended Vuza canon of order 144. The parameters become: $p_1 = 4$, $n_1 = 2$, $p_2 = 3$, $n_2 = 3$, and $n_3 = 2 \cdot 2 = 4$.

In this case, the factor \bar{L} of A remains a factor of $A^{\bar{n}_3}$ after the application of the \bar{n}_3 -operation: it is in fact an extension of a proper subset L of $\mathbb{Z}_{n_3} \subset \mathbb{Z}_{\bar{n}_3}$. In this case, however, it is necessary to choose a suitable set $K^{\bar{n}_3}$ such that $K^{\bar{n}_3} \oplus L = \mathbb{Z}_{n_3}$. In general, the observations made in the case of the n_3 -operation applied to a non-extended Vuza canon continue to be valid.

Figure 3.29 shows an example referring to a generic extended Vuza canon of period 144 to which we applied the \bar{n}_3 -operation.

p_1 -operation ($i = 1, 2$)

Definition 23 (\bar{p}_1 -operation). Let $A \oplus B = \mathbb{Z}_n$ be a (extended) Vuza canon and let $\bar{p}_1 = \theta p_1$, with $\theta \in \mathbb{N}^*$, such that \bar{p}_1 , n_1 , p_2 , n_2 , and n_3 satisfy conditions 1, 2, and 3. The \bar{p}_1 -operation on $A \oplus B = \mathbb{Z}_n$ produces the new (extended) Vuza canon:

$$Oper_{\bar{p}_1}(A \oplus B) = A^{\bar{p}_1} \oplus B^{\bar{p}_1} = \mathbb{Z}_{\theta n},$$

with

$$\begin{aligned}
A^{\bar{p}_1} &= n_3 \bar{p}_1 n_1 \tilde{A}_1 \oplus n_3 p_2 n_2 \tilde{A}_2^{\bar{p}_1} \oplus \bar{L} \\
B^{\bar{p}_1} &= \left(\left(U_1^{\bar{p}_1} \oplus n_3 n_1 \tilde{V}_2^{1, \bar{p}_1} \oplus \{k_1^1, \dots, k_1^{l_1}\} \right) \sqcup \dots \right. \\
&\quad \left. \dots \sqcup \left(U_1^{\bar{p}_1} \oplus n_3 n_1 \tilde{V}_2^{j, \bar{p}_1} \oplus \{k_1^{l_{j-1}+1}, \dots, k_1^{|K_1|}\} \right) \right) \sqcup \\
&\quad \left(\left(U_2^{\bar{p}_1} \oplus n_3 n_2 \tilde{V}_1^1 \oplus \{k_2^1, \dots, k_2^{m_1}\} \right) \sqcup \dots \right. \\
&\quad \left. \dots \sqcup \left(U_2^{\bar{p}_1} \oplus n_3 n_2 \tilde{V}_1^h \oplus \{k_2^{m_{h-1}+1}, \dots, k_2^{|K_2|}\} \right) \right) \\
&\quad \sqcup (n_3 n_1 n_2 \mathbb{I}_{\bar{p}_1 p_2} \oplus K_3),
\end{aligned}$$

where

- $U_1^{\bar{p}_1} = n_3 \bar{p}_1 n_1 n_2 \mathbb{I}_{p_2}$;
- $U_2^{\bar{p}_1} = n_3 p_2 n_2 n_1 \mathbb{I}_{\bar{p}_1}$;
- $\tilde{A}_2^{\bar{p}_1}$ is a complete aperiodic set of coset representatives for $\mathbb{Z}_{\bar{p}_1 n_1}$ modulo $n_1 \mathbb{I}_{\bar{p}_1}$;
- $\tilde{V}_2^{1, \bar{p}_1}, \dots, \tilde{V}_2^{h, \bar{p}_1}$ are complete aperiodic sets of coset representatives for $\mathbb{Z}_{\bar{p}_1 n_2}$ modulo $\bar{p}_1 \mathbb{I}_{n_2}$;

The definition is completely symmetric for the \bar{p}_2 -operation.

As in the case of \bar{n}_1 -operation, we notice that $R_A \subset R_{A^{\bar{p}_1}}$ by construction. Also note that $S_A = S_{A^{\bar{p}_1}}$, which implies that $|A^{\bar{p}_1}| = |A|$. Instead, $S_B \subsetneq S_{B^{\bar{p}_1}}$, incorporating the new prime powers introduced by θ . As a consequence, $|B^{\bar{p}_1}| = \theta |B|$.

The effect of the \bar{p}_1 -operation in the lattice of cyclotomic indices of $A \oplus B$ can be seen only in the complex hull representing $n_3 \bar{p}_1 n_1 \tilde{A}_1$: there is an expansion by factor θ of both the edge obtained as the difference between the convex hull of $n_3 p_1 n_1 \mathbb{I}_{n_2}$ and the convex hull of the cyclotomic indices of \tilde{A}_1 , and the convex hull \tilde{A}_1 itself. Figures 3.30 and 3.31 show two examples referring to our generic extended Vuza canon of period 72 to which we applied the \bar{p}_i -operation, for $i = 1, 2$: θ is a prime that already divided n (these are the 36 rhythms B for $n = 144$ and the 168 rhythms B for $n = 216$ analyzed in Table 3.4).

Rearrangement of K

As we have seen in Theorem 7 and 8, another possible way to pass from a (extended) Vuza canon to another, is to consider a different way to partition the set K and choose different sets K_1, K_2 (and maybe K_3). This time, the cyclotomic polynomials which divide, respectively, the inner rhythm and the outer rhythm, remain the same.

Figure 3.30: $n = 144$. $A_{CM} = 18\mathbb{I}_2 \oplus 16\mathbb{I}_3$.

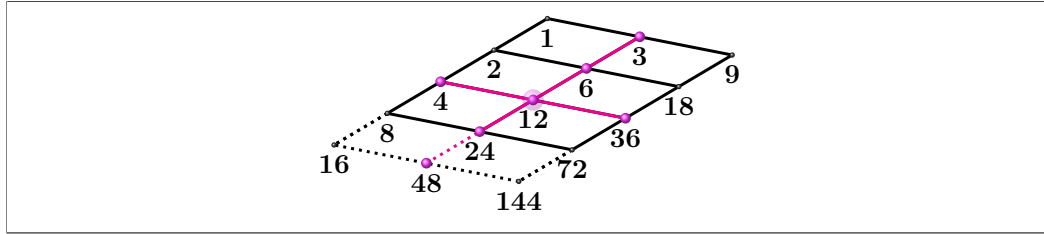

$p_1 = 4$ -operation on a Vuza canon of order 72. The parameters become: $p_1 = 2 \cdot 2 = 4$, $n_1 = 2$, $p_2 = 3$, $n_2 = 3$, and $n_3 = 2$. $L = \{0\}$. $\#B = 36$.

Figure 3.31: $n = 216$. $A_{CM} = 54\mathbb{I}_2 \oplus 8\mathbb{I}_3$.

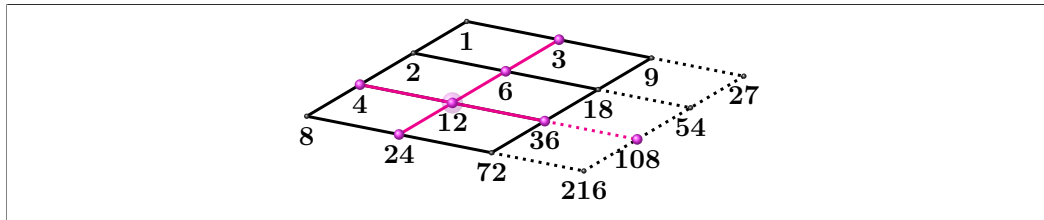

$p_2 = 9$ -operation on a Vuza canon of order 72. The parameters become: $p_1 = 2$, $n_1 = 2$, $p_2 = 3 \cdot 3 = 9$, $n_2 = 3$, and $n_3 = 2$. $L = \{0\}$. $\#B = 168$.

Substitution of \tilde{A}_i, \tilde{V}_i ($i = 1, 2$)

We are left to consider also the effects of Theorem 9 and Theorem 10. In these cases, we are going to substitute the sets $\tilde{A}_1, \tilde{A}_2, \tilde{V}_1, \tilde{V}_2$ with other coset representatives. The cyclotomic polynomials which divide A and B will not change, (or at least, the essential cyclotomic polynomials will not change) so the lattices of cyclotomic indices of the new (extended) Vuza canon will not show any changes.

Substitution of prime factors

The lattice representation of the two complementary rhythms of an aperiodic tiling rhythmic canon leads naturally to an operation on the prime factors of n : indeed, it is obvious that all the geometric properties of the lattice representation do not depend on *which* primes are the factors of n , but only on their relations. It is easy to see that (only with a small exception for the prime $p = 2$ in Theorem 7, where we need that a parameter be at least 3) if we exchange the primes in n with other ones, keeping the structure of the factorisation of n unchanged, a (extended) Vuza canon will be transformed into a new (extended) Vuza canon.

Chapter 4

Algorithms for aperiodic complements

Numerous algorithms have been devised by various mathematicians for the computation of aperiodic canons. An essential part of the construction of rhythmic canons is the search for e.g. the outer voice B , knowing the inner one A . In this chapter, we show some algorithms used for the generation of aperiodic motifs tiling with a given inner rhythm and within a given period.

The first two known procedures that we illustrate in Section 4.1 and Section 4.2 are the application of Coven-Meyerowitz theorem in [9] (which is not exhaustive for the research of all possible aperiodic tiling complements) and the Kolountzakis and Matolcsi *Fill-Out Procedure* in [21] (which is exhaustive).

We then go on presenting two new algorithms in Section 4.3 and Section 4.4 (which are the fruit of a joint work with G. Auricchio, L. Ferrarini, S. Gualandi, and L. Pernazza) for the exhaustive search of (aperiodic) tiling motifs, one in integer linear programming language (the *CS Algorithm*) and the other in SAT encoding. We show how these models can be used to efficiently check the necessity of the Coven-Meyerowitz condition (T2) and also to define an iterative algorithm that, given a period n , finds all the rhythms which tile with a given rhythm A . To conclude, we run several experiments to validate the time efficiency of both models.

We proceed in Section 4.5 taking advantage of the fastest procedure in connection with the Coven-Meyerowitz formula to realise the complete enumeration of the aperiodic canons with periods $n = 180$ and $n = 200$. We conclude this chapter by showing that for period $n = 900$ there exist aperiodic canons that are not extended Vuza canons; this is an observation that projects the investigation of aperiodic canons and their structure towards new interesting conjectures and directions.

4.1 The Coven-Meyerowitz complement

In this section we show how to apply the Coven-Meyerowitz Theorem to obtain a complementary motif, given the inner rhythm and the period of the final canon. In general, the

Coven-Meyerowitz theorem does not provide an aperiodic complement; however, there are some conditions for which one can be sure that the final result will indeed be an aperiodic canon.

Proposition 9 (Coven, Meyerowitz). *If $A \subset \mathbb{Z}_n$ satisfies conditions (T1) and (T2), then a complement of A in \mathbb{Z}_n (i.e., B_{CM} satisfying $A \oplus B_{CM} = \mathbb{Z}_n$) can be defined taking as its characteristic polynomial:*

$$B_{CM}(x) = \prod_{\substack{p^\alpha | n \\ p^\alpha \notin S_A}} \Phi_{p^\alpha} \left(x^{\frac{n}{p^\nu(p)}} \right) = \prod_{\substack{p^\alpha | n \\ p^\alpha \notin S_A}} \Phi_p \left(x^{\frac{np^{\alpha-1}}{p^\nu(p)}} \right),$$

where $n = \prod_i p_i^{\nu(p_i)}$ is the decomposition of n into prime powers.

This proposition allows us to define the *Coven-Meyerowitz complement* as a set.

Definition 24 (Coven-Meyerowitz complement). We define *Coven-Meyerowitz complement* the rhythm $B_{CM} \subset \mathbb{Z}_n$ obtained as

$$B_{CM} = \bigoplus_{\substack{p^\alpha | n \\ p^\alpha \notin S_A}} \frac{np^{\alpha-1}}{p^\nu(p)} \mathbb{I}_p$$

(the Proposition above ensures that $A \oplus B_{CM} = \mathbb{Z}_n$).

Example 17. Consider a generic aperiodic inner rhythm $B \subset \mathbb{Z}_{4500}$ such that $S_B = \{3, 4, 5, 9, 125\}$. A rhythm with these characteristics could be, for example, the extended Vuza rhythm

$$B = 1500\mathbb{I}_3 \oplus 250\mathbb{I}_2 \oplus \{0, 1, 2, 3, 4, 25, 26, 27, 28, 29, 50, 51, 52, 53, 54\} \\ \sqcup 2250\mathbb{I}_2 \oplus 375\mathbb{I}_3 \oplus \{75, 76, 77, 78, 79, 100, 101, 102, 103, 104\}.$$

The Coven-Meyerowitz complement is given by

$$A_{CM} = (9 \cdot 125)\mathbb{I}_2 \oplus (4 \cdot 125)\mathbb{I}_3 \oplus (4 \cdot 9 \cdot 5)\mathbb{I}_5.$$

Figure 4.1 shows the lattice representation of A_{CM} : R_A is graphically represented as the union of the hyperplanes which, starting from the vertices $p^\alpha \notin S_B$, extend along all the orthogonal axes, those corresponding to the prime powers that divide n and are different from p , to include all multiples of p^α (dividing n) which are not multiples of $p^{(\alpha+1)}$.

Example 18. Now suppose that our starting motif is the Coven-Meyerowitz complement of Example 17:

$$A = 1125\mathbb{I}_2 \oplus 500\mathbb{I}_3 \oplus 180\mathbb{I}_5 \subset \mathbb{Z}_{4500}.$$

The Coven-Meyerowitz complement is given by

$$B_{CM} = (2 \cdot 9 \cdot 125)\mathbb{I}_2 \oplus (3 \cdot 4 \cdot 125)\mathbb{I}_3 \oplus (4 \cdot 9)\mathbb{I}_5 \oplus (4 \cdot 9 \cdot 25)\mathbb{I}_5$$

as shown by its lattice representation in Figure 4.2. It is evident that, in this case, the Coven-Meyerowitz complement is periodic of periods n/p_i , for every prime $p_i | n$.

Figure 4.1: $n = 4500$. $A_{CM} = 1125\mathbb{I}_2 \oplus 500\mathbb{I}_3 \oplus 180\mathbb{I}_5$.

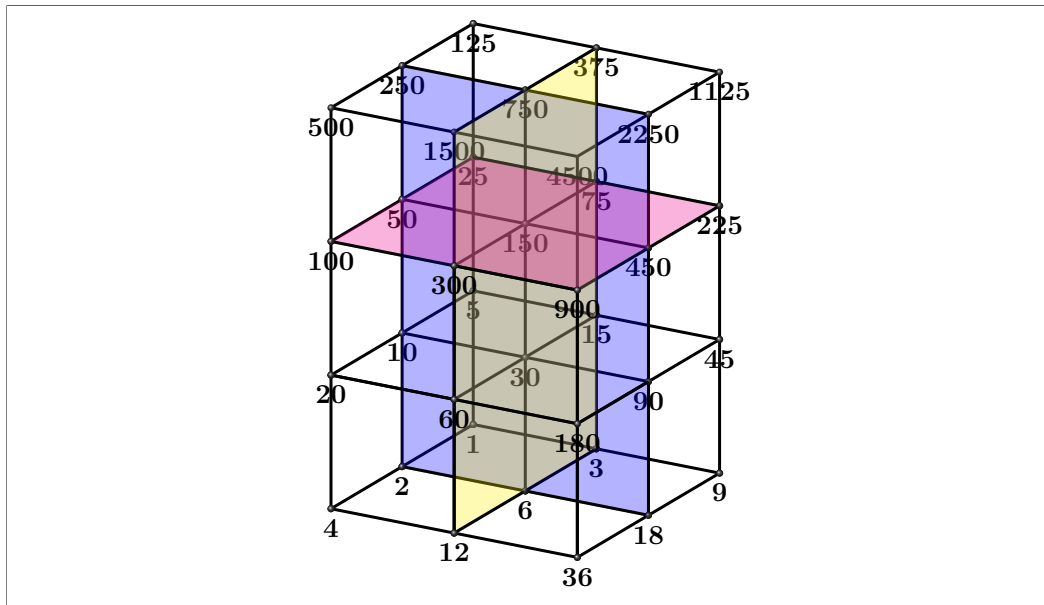

Lattice representation of $A_{CM} = (9 \cdot 125)\mathbb{I}_2 \oplus (4 \cdot 125)\mathbb{I}_3 \oplus (4 \cdot 9 \cdot 5)\mathbb{I}_5$ when $S_B = \{4, 5, 9, 125\}$.

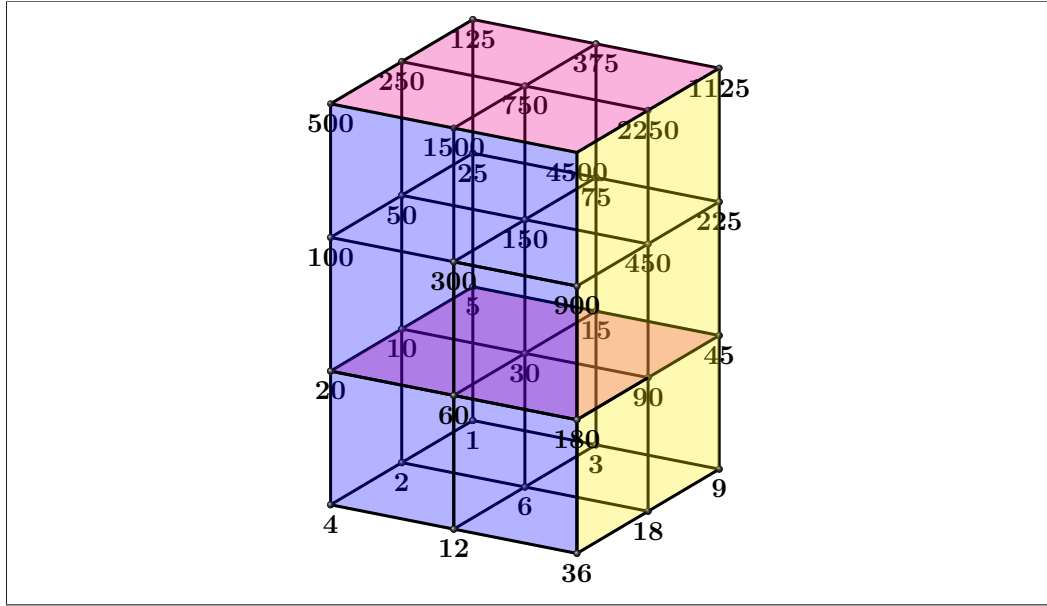
Figure 4.2: $n = 4500$. $B_{CM} = 2250\mathbb{I}_2 \oplus 1500\mathbb{I}_3 \oplus 36\mathbb{I}_5 \oplus 900\mathbb{I}_5$.

Lattice representation of $B_{CM} = (2 \cdot 9 \cdot 125)\mathbb{I}_2 \oplus (3 \cdot 4 \cdot 125)\mathbb{I}_3 \oplus (4 \cdot 9)\mathbb{I}_5 \oplus (4 \cdot 9 \cdot 25)\mathbb{I}_5$ when $S_A = \{2, 3, 25\}$.

Example 17 and Example 18 are instances of the following trivial observation.

Remark 4. Consider $A \oplus B_{CM} = \mathbb{Z}_n$. B_{CM} is aperiodic if and only if S_A contains all the maximum prime powers that divide n .

An interesting detail is the fact that the Coven-Meyerowitz complement actually has a factorisation very similar to that of the (extended) Vuza motifs A . Indeed, the Coven-Meyerowitz complement falls among these ones precisely under the hypotheses of Remark 4, i.e. that no element of $S_{B_{CM}}$ is a maximum power (with respect to the factorisation of n). Conversely, an extended Vuza motif A can be considered a Coven-Meyerowitz complement when n_1 and n_2 are prime powers and the factor \bar{L} , if present, is of the form

$$\bar{L} = \bigoplus_{p^\alpha | n_3} \frac{np^{\alpha-1}}{p^{\nu(p)}} \mathbb{I}_p,$$

that is, \bar{L} is itself a Coven-Meyerowitz complement of another rhythm in \mathbb{Z}_n .

As a last comment, we underline that the application of the Coven-Meyerowitz theorem does not provide an exhaustive algorithm for the search of the complements of a given motif in a given cyclic group \mathbb{Z}_n : on the contrary, they provide a unique complement for each choice of n and $S_{B_{CM}}$.

4.2 The Fill-Out Procedure

In [21], M. N. Kolountzakis and M. Matolcsi used the Coven-Meyerowitz complement and a new heuristic algorithm called *Fill-Out Procedure*, which they applied twice for an exhaustive search for aperiodic canons (with a given n and S_A). The key idea behind the last one is the following: given a rhythm $A \subseteq \mathbb{Z}_n$ such that $0 \in A$, the algorithm sets $P = \{0\}$ and starts the search for possible expansions of the set P . The expansion is accomplished adding an element $\alpha \in \mathbb{Z}_n$ to P according to the reverse order induced by a ranking function $r(x, P)$, which counts all the possible ways in which x can be covered through a translation of A . Once every element of $\mathbb{Z}_n \setminus (A \oplus P)$ has been ranked, the algorithm tries to add the element with the lowest rank. Adding a new element defines a new set, namely $\tilde{P} \supset P$, which is again expanded until either it can no longer be expanded or the set becomes a tiling complement. The search ends when all the possibilities have been explored.

The *Fill-Out procedure* is exhaustive, but, given an inner rhythm in a given cyclic group \mathbb{Z}_n , it finds all the tiling complements, regardless of whether they are periodic or aperiodic. The algorithm finds also multiple translations of the same rhythm, which we consider equivalent: this means that there are many solutions that must be removed in post-processing to obtain a list of aperiodic canons without repetitions.

In their work, Kolountzakis and Matolcsi carry out a complete classification of all aperiodic tiling of \mathbb{Z}_{144} ; however, the method described is not convenient to classify all aperiodic tiling for periods > 200 . Indeed, the number of aperiodic tiling increases to at least exponentially with n (see [21]):

Theorem 17 (Kolountzakis, Matolcsi). *There are arbitrarily large n and aperiodic tilings $\mathbb{Z}_n = A \oplus B$, such that there are additional distinct aperiodic tiling complements B_1, \dots, B_k of A , with $k \geq e^{C\sqrt{n}}$, with C a constant.*

4.3 The Cutting Sequential Algorithm

In this section, we propose an Integer Linear Programming Model (ILP) whose solutions are the aperiodic rhythms tiling with a given rhythm A . In particular, we formulate the *Aperiodic Tiling Complements Problem* using ILP model that is based on the polynomial characterisation of tiling canons. The ILP model uses auxiliary 0–1 variables to encode the product $A(x) \cdot B(x)$ which characterises tiling canons. The aperiodicity constraint is also formulated in terms of 0 – 1 variables; the objective function is equal to a constant and has no influence on the solutions found by the model. The ILP model is coupled with a sequential cutting algorithm that adds a no-good constraint every time a new canon B is found, to prevent finding solutions twice. In addition, the sequential algorithm sets new no-good constraints, one for each translation of B ; hence, in contrast to the *Fill-Out Procedure*, the *CS Algorithm* needs no post-processing.

The purpose of the model is twofold. First, we want to determine, for a given rhythm A , all the tiling complements B in \mathbb{Z}_n . In this case, we are interested not only in testing the tiling property but also in finding all the complements of A . Given a rhythm A

and a period n , the Matolcsi and Kolountzakis' *Fill-Out Procedure* provides a complete classification of the complements of A in \mathbb{Z}_n [21]. The main idea behind this algorithm is to use packing complements and add one by one the new elements discovered by an iterative search. At the best of our knowledge, this is the only algorithm able to provide the complete list of complements of a given rhythm, for $n \leq 200$. For larger n the problem has been considered in [19], but the author was able to give only a lower bound to the number of tiling complements. Therefore, we choose to compare our performances with the one of the *Fill-Out Procedure*.

Secondly, we aim to determine if a given aperiodic rhythm A , that does not satisfy the (T2) property, tiles with an aperiodic rhythm B . This could be used to efficiently test possible counterexamples to the necessity of condition (T2) [3].

The tiling problem is very similar to the decision problem of DIFF studied in [20], which is shown to be NP-complete. This suggests a lower bound on the computational complexity of the tiling decision problem. Since our problem consists in solving a linear system of $3n - 1$ unknowns and $3n + 3(M_n(p) - 1)$ constraints, the complexity of finding a single aperiodic solution is $O(n^c + 3M_n(p))$, where $M_n(p)$ denotes the number of all distinct primes in the factorisation of n . However, Kolountzakis argued that verification of condition (T2) can be done in polynomial time. So if condition (T2) were necessary for tiling, the problem would be P-complete.

As we will see, solving this linear problem finds us only one of the possible solutions. However, we can update the problem by removing the found solution from the feasible set. If we solve the updated problem, we are then able to find a new solution. By iterating this process until the problem cannot be solved we will find all the tiling complements of the given rhythm A .

Since we are not interested in looking for all the possible solutions but rather for all the classes of equivalent rhythms modulo translations or affine transformations, we can customise the constraints added at each step. In particular, if we are interested in finding all the solutions modulo affine transformations, the number of constraints to add at each iteration is equal to the cardinality of $\mathcal{P} = \{a \in \mathbb{N} : \gcd(a, n) = 1\}$ times the cardinality of the set of all translations fixing the first entry of the solution equal to 1. Therefore, we add $O\left(|\mathcal{P}| \frac{n}{n_A}\right)$ new constraints at every iteration, where n_A is the cardinality of the rhythm A . As a result, finding new tiling rhythms gets harder at each iteration.

An important property exploited in this algorithm is the invariance of the set of solutions under affine transformations, that is, any affine transformation sends tiling solutions into tiling solutions.

Remark 5. Recall that a set A is periodic modulo $k \mid n$ if and only if

$$\frac{x^n - 1}{x^k - 1} \mid A(x).$$

Whenever a rhythm A is periodic modulo $k \mid n$, with $k \neq n$, it is periodic modulo all multiples of k dividing n . For this reason, when it comes to check whether A is periodic or not, it suffices to check if it is periodic modulo $m_1 = p_1^{\alpha_1 - 1} p_2^{\alpha_2} \dots p_N^{\alpha_N}$, $m_2 =$

$p_1^{\alpha_1} p_2^{\alpha_2-1} \dots p_N^{\alpha_N}$, \dots , $m_N = p_1^{\alpha_1} p_2^{\alpha_2} \dots p_N^{\alpha_N-1}$, where $n = p_1^{\alpha_1} p_2^{\alpha_2} \dots p_N^{\alpha_N}$ is the prime powers factorization of n .

Our main result is Theorem 18, where we state that imposing the aperiodicity of the solution can be done through linear constraints. Finally, we show how solving a sequence of increasingly harder linear problems leads to a complete enumeration of all the tiling complements of a given rhythm A .

4.3.1 Tiling constraints

First of all, we define the linear equations that describe the tiling property. Let us take an inner rhythm A and a possible outer rhythm B . Since the degrees of their characteristic polynomials, $A(x)$ and $B(x)$, are both less than or equal to $n - 1$, the degree of the product $R(x)$ is less than or equal to $2n - 2$. We denote by r the vector with $2n - 1$ entries containing the coefficients of the polynomial $R(x) := A(x)B(x)$. By Remark 2, we know that B tiles with A if and only if

$$R(x) \equiv 1 + x + x^2 + \dots + x^{n-1}, \quad \text{mod } x^n - 1. \quad (4.1)$$

We can express condition (4.1) through n linear equations

$$r_i + r_{i+n} = 1, \quad \forall i = 0, \dots, n - 1.$$

Therefore, we can express the constraint

$$R(x) = A(x)B(x) \equiv \sum_{i=0}^{n-1} x^i, \quad \text{mod } x^n - 1,$$

through the linear system

$$\begin{aligned} F_i(B) - r_i &= 0 & \forall i \in \{0, \dots, 2n - 2\}, \\ r_j + r_{j+n} &= 1 & \forall j \in \{0, \dots, n - 1\}, \end{aligned}$$

where $F_i(B)$ is the function that associates to a rhythm B the i -th coefficient of $A(x)B(x)$, that is

$$\begin{aligned} F_0(B) &:= a_0 b_0, \\ F_1(B) &:= a_1 b_0 + a_0 b_1, \\ F_2(B) &:= a_2 b_0 + a_1 b_1 + a_0 b_2, \\ &\vdots \\ F_{2n-2}(B) &:= a_{n-1} b_{n-1}, \end{aligned}$$

where $b = (b_0, b_1, \dots, b_{n-1})$ are the coefficients of $B(x)$. Notice that, since A is given, all the equations presented above are linear with respect to the variables b_i and r_i . We then can express them through a linear system

$$\mathcal{A} \cdot \mathcal{X} = \mathcal{Y}, \quad (4.2)$$

where

- \mathcal{A} is a $(3n - 1) \times (3n - 1)$ matrix which depends only on the given rhythm A ,
- $\mathcal{X} = (b, r)^T$ is the vector composed by the coefficients of $B(x)$ and the coefficients of R ;
- \mathcal{Y} is the $(3n - 1)$ -dimensional vector defined as

$$\mathcal{Y}_i = \begin{cases} 0 & \text{if } i \in \{0, \dots, 2n - 2\}, \\ 1 & \text{otherwise.} \end{cases}$$

Finally, in order to ensure that $B(x)$ and $R(x)$ are polynomials with coefficients in $\{0, 1\}$, we will require b_i and r_i to be binary variables, i.e. they can only assume value 0 or 1.

4.3.2 Aperiodicity constraints

We impose now the aperiodicity constraints. Let us assume $n = p_1^{\alpha_1} p_2^{\alpha_2} \dots p_N^{\alpha_N}$. Without loss of generality, we can suppose

$$p_1 < p_2 < \dots < p_N$$

and, therefore, if we define the set of the maximal divisors of n as $\mathcal{M}_n := \{m_k = \frac{n}{p_k}\}_{k=1, \dots, N}$, we have

$$m_N < m_{N-1} < \dots < m_1.$$

According to Remark 5, to verify if the rhythm B is periodic or not, it is sufficient to check its periodicity only for periods in \mathcal{M}_n . We can characterize the periodicity with respect to a given period m_j as it follows.

Proposition 10. *Let B be a rhythm in \mathbb{Z}_n , let b be the binary vector containing the coefficients of p_B , and let $m_j \in \mathcal{M}_n$. Then, B is m_j -periodic if and only if*

$$\sum_{r=0}^{p_j-1} b_{i+rm_j} = \begin{cases} p_j & \text{if } i \in B \\ 0 & \text{otherwise,} \end{cases} \quad (4.3)$$

for each $i = 0, \dots, m_j - 1$.

Proof. Let us assume $B \subset \mathbb{Z}_n$ is m_j -periodic. We prove that (4.3) holds. By Definition 7, we have that

$$i \in B \iff i + rm_j \in B \quad (4.4)$$

for each $r = 0, \dots, p_j - 1$. Let b be the vector of the coefficients of p_B . By equation (4.4), we get

$$b_i = 0 \iff b_{(i+rm_j) \bmod n} = 0 \quad \text{for } r = 0, \dots, p_j - 1, \quad (4.5)$$

$$b_i = 1 \iff b_{(i+rm_j) \bmod n} = 1 \quad \text{for } r = 0, \dots, p_j - 1, \quad (4.6)$$

therefore, for any given $i = 0, \dots, m_j - 1$, we have

$$\sum_{r=0}^{p_j-1} b_{i+rm_j} = \begin{cases} p_j & \text{if } i \in B \\ 0 & \text{otherwise,} \end{cases}$$

which concludes the first half of the proof.

Let us now assume that (4.3) holds and fix $i \in \{0, \dots, m_j - 1\}$. If

$$\sum_{r=0}^{p_j-1} b_{i+rm_j} = 0,$$

we have $b_{i+rm_j} = 0$ for each $r = 0, \dots, p_j - 1$, since each b_k is either equal to 0 or 1, which is equivalent to (4.5). Similarly, if

$$\sum_{r=0}^{p_j-1} b_{i+rm_j} = p_j,$$

we have $b_{i+rm_j} = 1$ for each $r = 0, \dots, p_j - 1$, which is equivalent to (4.6). Since (4.5) and (4.6) are equivalent to the m_j -periodicity of B , the thesis follows. \square

Let us take $m_j \in \mathcal{M}_n$. To impose that the rhythm B is not m_j -periodic, we introduce the family of auxiliary variables

$$\mathcal{U}^{(j)} := \{U_i^{(j)}\}_{i=1, \dots, m_j-1}.$$

Each family $\mathcal{U}^{(j)}$ is composed of binary variables subject to the following constraints:

$$\sum_{k=0}^{p_j-1} b_{i+km_j} - p_j U_i^{(j)} \leq p_j - 1, \quad (4.7)$$

$$\sum_{k=0}^{p_j-1} b_{i+km_j} - p_j U_i^{(j)} \geq 0, \quad (4.8)$$

$$\sum_{i=0}^{m_j-1} U_i^{(j)} \leq \frac{n_B}{p_j} - 1, \quad (4.9)$$

for each j such that $p_j | n_B$ and for each $i = 0, \dots, m_j - 1$, where n_B is the cardinality of B .

Since $\sum_{k=0}^{p_j-1} b_{i+km_j} \leq p_j$, condition (4.7) assures us that $U_i^{(j)} = 1$ if

$$\sum_{k=0}^{p_j-1} b_{i+km_j} = p_j.$$

Condition (4.8) assures us that $U_i^{(j)} = 1$ only if

$$\sum_{k=0}^{p_j-1} b_{i+km_j} = p_j.$$

Therefore, conditions (4.7) and (4.8) combined, assure us that

$$U_i^{(j)} = 1 \iff \sum_{k=0}^{p_j-1} b_{i+km_j} = p_j.$$

Since $\sum_{i=0}^{n-1} b_i = n_B$, if $\sum_{i=0}^{m_j-1} U_i^{(j)} = \frac{n_B}{p_j}$, it follows that

$$\sum_{k=0}^{p_j-1} b_{i+km_j} = \begin{cases} p_j & \text{if } U_i^{(j)} = 1 \\ 0 & \text{otherwise,} \end{cases}$$

and, hence, according to Proposition 10, B is m_j -periodic. By adding the constraints (4.7), (4.8), and (4.9) to the linear system, we, therefore, remove all the periodic solutions from the feasible set.

Remark 6. To improve efficiency, we remove a family of auxiliary variables $\mathcal{U}^{(j)} := \{U_i^{(j)}\}$ imposing

$$\sum_{i=0}^{m_j-1} b_i \leq \frac{n_B}{p_j} - 1. \quad (4.10)$$

Indeed, if $B = (b_0, b_1, \dots, b_{n-1})$ is not m_j -periodic, there must exist a translation of B such that (4.10) holds. Since $U^{(1)}$ is the family containing the highest number of variables, and therefore the one more memory demanding, we choose to remove it.

Conditions (4.7)–(4.9) and (4.10) are linear for any j , therefore, we can add them to the system described in (4.2) and obtain the following Integer Linear Programming (ILP) problem

$$\min \mathcal{O}(\{b_i\}, \{r_i\}, U) \quad (4.11)$$

$$\text{s.t.} \quad \sum_{j=0}^i a_{i-j} b_j - r_i = 0 \quad \forall i \in \{0, \dots, n-1\}, \quad (4.12)$$

$$\sum_{j=0}^{i+1} a_{n-(i-j)} b_j - r_{i+n} = 0 \quad \forall i \in \{0, \dots, n-2\}, \quad (4.13)$$

$$r_j + r_{j+n} = 1 \quad \forall j \in \{0, \dots, n-1\} \quad (4.14)$$

$$\sum_{j=0}^{m_0-1} b_j \leq n_B \frac{m_0}{n} - 1, \quad (4.15)$$

$$\sum_{k=0}^{p_j-1} b_{i+km_j} - p_j U_i^{(j)} \leq p_j - 1, \quad \forall j \in \{1, \dots, N\}, \quad (4.16)$$

$$\forall i \in \{0, \dots, m_j - 1\},$$

$$\sum_{k=0}^{p_j-1} b_{i+km_j} - p_j U_i^{(j)} \geq 0, \quad \forall j \in \{1, \dots, N\}, \quad (4.17)$$

$$\forall i \in \{0, \dots, m_j - 1\},$$

$$\sum_{i=0}^{m_j-1} U_i^{(j)} \leq \frac{n_B}{p_j} - 1, \quad \forall j \in \{1, \dots, N\}, \quad (4.18)$$

$$\forall i \in \{0, \dots, m_j - 1\},$$

$$b_0 = 1, \quad (4.19)$$

$$b_k \in \{0, 1\} \quad \forall k \in \{1, \dots, n-1\},$$

$$r_k \in \{0, 1\} \quad \forall k \in \{0, \dots, 2n-2\},$$

$$U_i^{(j)} \in \{0, 1\} \quad \forall j \in \{1, \dots, N\},$$

$$\forall i \in \{0, \dots, m_j - 1\},$$

where \mathcal{O} is a suitable linear function to minimize. The constraint (4.19) allows us to reduce the size of the feasible set by removing a degree of freedom from the possible solutions. We denote the model just introduced as the Master Problem (MP).

Theorem 18. *Given an inner rhythm A in \mathbb{Z} , let $\hat{\mathcal{Y}} = (b, r)$ be a solution of MP. Then, the rhythm associated to the characteristic polynomial*

$$B(x) := \sum_{i=0}^{n-1} b_i x^i,$$

is aperiodic and tiles with A .

Remark 7. The set of constraints of the MP fully characterize the possible aperiodic rhythms tiling with a given rhythm A . The functional \mathcal{O} does not play any role; however it can be used to induce an order or a selection criteria on the space of solutions. For example, let us consider the following functional

$$\mathcal{O}(b, r) := \sum_{i=0}^{2n-2} i^2 b_i.$$

This functional prefers the tiling complements whose first components are as full as possible of 1's. Choosing the right functional \mathcal{O} can help in discerning, among all the possible tiling complements of the given rhythm A , the ones we want to find. However, since the aim of our tests is to find all the possible tilings, we will not need to impose any selection criteria and, therefore, we set

$$\mathcal{O}(b, r) := 0.$$

Once we find an aperiodic rhythm $B^{(1)}$ tiling with a given rhythm A , we can remove $B^{(1)}$ from the set of all possible solutions D_A and obtain a new set of feasible solutions $D_A^{(1)}$. Let us denote with $MP^{(1)}$ the restriction on $D_A^{(1)}$ of MP and call $B^{(2)}$ the solution of $MP^{(1)}$, we can then remove this solution from $D_A^{(1)}$, define the set $D_A^{(2)}$, and define $MP^{(2)}$, starting the whole process again. Repeating this process until we find an unsolvable problem, we retrieve all the possible solutions of the original Master Problem and, therefore, we generate all the aperiodic rhythms tiling with the rhythm A .

Let us now detail how to cut out from the feasible set the solution found at each iteration. Let $B^{(1)}$ be a rhythm tiling with A and let $b^{(1)} = (b_0, \dots, b_{n-1})$ be the coefficients of its characteristic polynomial. We denote with $I^{(1)}$ the set of non-zero coordinate indexes of the vector $b^{(1)}$, that is

$$I^{(1)} := \left\{ i \in \{0, \dots, n-1\} \mid b_i = 1 \right\}.$$

We then define a new linear system by adding the constraint

$$\sum_{i \in I^{(1)}} b_i^{(1)} \neq \frac{n}{n_A}, \quad (4.20)$$

or equivalently

$$\sum_{i \in I^{(1)}} b_i^{(1)} \leq \frac{n}{n_A} - 1, \quad (4.21)$$

to the MP. By solving this new problem, we find a new solution $b^{(2)} \neq b^{(1)}$ of the initial tiling problem. We iterate this procedure until we find an unsolvable problem. All the solutions found during this process are stored in memory and given as final output of the algorithm.

In Algorithm 1, we sketch the pseudocode of this algorithm.

Input : rhythm A
Output: S , list of Aperiodic rhythms B , such that $A \oplus B = \mathbb{Z}_n$
 $z^* = OPT(MP)$
 add z^* to S
while $P \neq \emptyset$ **do**
 add $\sum_{i \in I_{z^*}} b_i \leq \beta$ to $(MP^{(i)})$
 Solve $(MP^{(i)})$
 $z_{new} = OPT(MP^{(i)})$
 set $I_{z^*} := I_{z_{new}}$
 add z_{new} to S
end
 return S

Algorithm 1: The Cutting Sequential Algorithm.

Remark 8. Adding the constraints one by one is highly inefficient. Therefore, once we find a solution, we compute all its affine transformations, which, according to Theorem 3, are possible solutions and remove them as well. Since we impose $b_0 = 1$, we consider only the affine transformations that preserve this constraint.

This procedure, however, is customizable: if we remove only the translations of the found solution the algorithm will return all the solutions modulo translations. Given a solution $b^{(1)}$, we can remove the affine transformations of a given solution through a linear constraint. According to (4.21), we impose

$$\sum_{i \in I^{(1)}} b_{a(i+k)} \leq n_B - 1 \quad (4.22)$$

where k runs over all the translations which fix the first position and a runs over the set of numbers co-prime with n .

Complexity of the Method

To conclude, we analyze the complexity of the system (4.2). The unknowns to determine are the $3n - 1$ coordinates of the vector (b, r) plus the variables needed to impose the aperiodicity constraints, $U_i^{(j)}$, which are

$$\sigma_n := \sum_{p \in \mathbb{P}_n \setminus \{p_0\}} \frac{n}{p},$$

where \mathbb{P}_n is the set of primes that divide n_B . Therefore, we have $3n - 1$ constraints for the feasibility, the $3\sigma_n$ given by conditions (4.16), (4.17), and (4.18) plus the one given by condition (4.15).

If we want a complete enumeration of all the tiling complements of the given rhythm, the complexity increases, since we are adding constraints at each iteration. The amount of constraints to add depends on the equivalence relation we are considering. If we are

Table 4.1: Number of tiling complements of the aperiodic rhythms tested.

n	R_A	R_B	n° of A 's	n° of B 's
72	{2, 8, 9, 18, 72}	{3, 4, 6, 12, 24, 36}	6 (2)	3 (1)
108	{3, 4, 12, 27, 108}	{2, 6, 9, 18, 36, 54}	252 (30)	3 (1)
120	{2, 5, 8, 10, 15, 30, 40, 120}	{3, 4, 6, 12, 20, 24, 60}	18 (4)	8 (2)
120	{2, 3, 6, 8, 15, 24, 30, 120}	{4, 5, 10, 12, 20, 40, 60}	20 (3)	16 (5)
144	{2, 8, 9, 16, 18, 72, 144}	{3, 4, 6, 12, 24, 36, 48}	36 (10)	6 (1)
144	{4, 9, 16, 18, 36, 144}	{2, 3, 6, 8, 12, 18, 24, 48, 72}	6 (2)	12 (9)
	{4, 9, 16, 18, 36, 144}	{2, 3, 6, 8, 12, 24, 48, 72}	6 (2)	312 (1)
144	{2, 9, 16, 18, 36, 144}	{3, 4, 6, 8, 12, 24, 36, 48, 72}	12 (2)	6 (1)
	{2, 9, 16, 18, 144}	{3, 4, 6, 8, 12, 24, 36, 48, 72}	48 (7)	6 (1)
	{2, 9, 16, 18, 36, 144}	{3, 4, 6, 8, 12, 24, 48, 72}	12 (2)	156 (9)
168	{2, 7, 8, 14, 21, 42, 56, 168}	{3, 4, 6, 12, 24, 28, 84}	54 (8)	16 (3)
168	{2, 3, 6, 8, 21, 24, 42, 168}	{4, 7, 12, 14, 28, 56, 84}	42 (4)	104 (15)
180	{3, 4, 5, 12, 15, 20, 45, 60, 180}	{2, 6, 9, 10, 18, 30, 36, 90}	2052 (136)	8 (2)
180	{2, 5, 9, 10, 18, 20, 45, 90, 180}	{3, 4, 6, 12, 15, 30, 36, 60}	96 (12)	6 (1)
180	{3, 4, 9, 12, 36, 45, 180}	{2, 5, 6, 10, 15, 18, 20, 30, 60, 90}	1800 (171)	16 (5)
180	{2, 4, 9, 18, 20, 36, 180}	{3, 5, 6, 10, 12, 15, 30, 45, 60, 90}	120 (18)	9 (2)

looking for all the solutions modulo translation, we add n_B constraints at each iteration, since there are exactly n_B feasible translations preserving the constraint $b_0 = 1$. If we search for all the solutions up to affine transformations, the number of constraints added is n_B times the quantity of numbers primes to n .

4.3.3 Computational results

We observe that the *CS Algorithm* is faster than the *Fill-Out Procedure*. We compare the two algorithms on rhythms in \mathbb{Z}_n , for $n = 72, 108, 120, 144, 168, 180$. We ran all our experiments on a ASUS VivoBook15 with Intelcore i7. The algorithm is implemented in Python using Gurobi v9.1.1, [13].

It is worth of mention that the *Fill-Out-Procedure* finds every complement modulo translation, while the CSA can be customized to compute every complement modulo all the affine transformations. We chose to run our method to compute all the solutions modulo affine transformation, The experiment we ran is the following: given a rhythm A , we list every complement. Afterwards, we reverse the problem: we fix one of the found complements, namely B , and search for all the complements of B . The rhythms used for our experiments are reported in Table 4.1 while, in Table 4.2, we compare the runtimes of CSA with the runtimes of the *Fill-Out Procedure*. The CSA is customized in order to find all the classes modulo affine transformations.

Every time we find a solution, we have to add new constraints to the Master Problem and solve it again. As a result, the problem we solve gets computationally harder at each iteration. In Figure 4.3, we report the time required to find the next tiling solution for two rhythms in \mathbb{Z}_{180} .

Figure 4.3: Times (in seconds) to find the next solution with *CS Algorithm*.

Table 4.2: Runtimes (in seconds) of the *CS Algorithm* and the *Fill-Out Procedure*.

n	R_A	R_B	CSA A	FP A	CSA B	FP B
72	{2, 8, 9, 18, 72}	{3, 4, 6, 12, 24, 36}	0.10	1.59	0.02	0.33
108	{3, 4, 12, 27, 108}	{2, 6, 9, 18, 36, 54}	7.84	896.06	0.03	0.72
120	{2, 5, 8, 10, 15, 30, 40, 120}	{3, 4, 6, 12, 20, 24, 60}	0.27	24.16	0.07	2.13
120	{2, 3, 6, 8, 15, 24, 30, 120}	{4, 5, 10, 12, 20, 40, 60}	0.14	10.92	0.15	3.30
144	{2, 8, 9, 16, 18, 72, 144}	{3, 4, 6, 12, 24, 36, 48}	2.93	82.53	0.06	3.77
144	{4, 9, 16, 18, 36, 144}	{2, 3, 6, 8, 12, 18, 24, 48, 72}	0.10	7.13	1.71	66.27
144	{4, 9, 16, 18, 36, 144}	{2, 3, 6, 8, 12, 24, 48, 72}				
144	{2, 9, 16, 18, 36, 144}	{3, 4, 6, 8, 12, 24, 36, 48, 72}	0.11	12.13	1.08	33.39
168	{2, 7, 8, 14, 21, 42, 56, 168}	{3, 4, 6, 12, 24, 28, 84}	17.61	461.53	0.13	7.91
168	{2, 3, 6, 8, 21, 24, 42, 168}	{4, 7, 12, 14, 28, 56, 84}	0.91	46.11	1.94	35.36
180	{3, 4, 5, 12, 15, 20, 45, 60, 180}	{2, 6, 9, 10, 18, 30, 36, 90}	1422.09	>3600	0.25	1243.06
180	{2, 5, 9, 10, 18, 20, 45, 90, 180}	{3, 4, 6, 12, 15, 30, 36, 60}	48.04	900.75	0.11	8.22
180	{3, 4, 9, 12, 36, 45, 180}	{2, 5, 6, 10, 15, 18, 20, 30, 60, 90}	492.18	>3600	0.18	7.51
180	{2, 4, 9, 18, 20, 36, 180}	{3, 5, 6, 10, 12, 15, 30, 45, 60, 90}	8.82	280.72	0.29	14.34

4.4 The SAT Encoding Algorithm

In this section, we present in parallel a second ILP model and a SAT encoding for the Aperiodic Tiling Complements Problem that are both used to enumerate all tiling complements of A in \mathbb{Z}_n (see [5]).

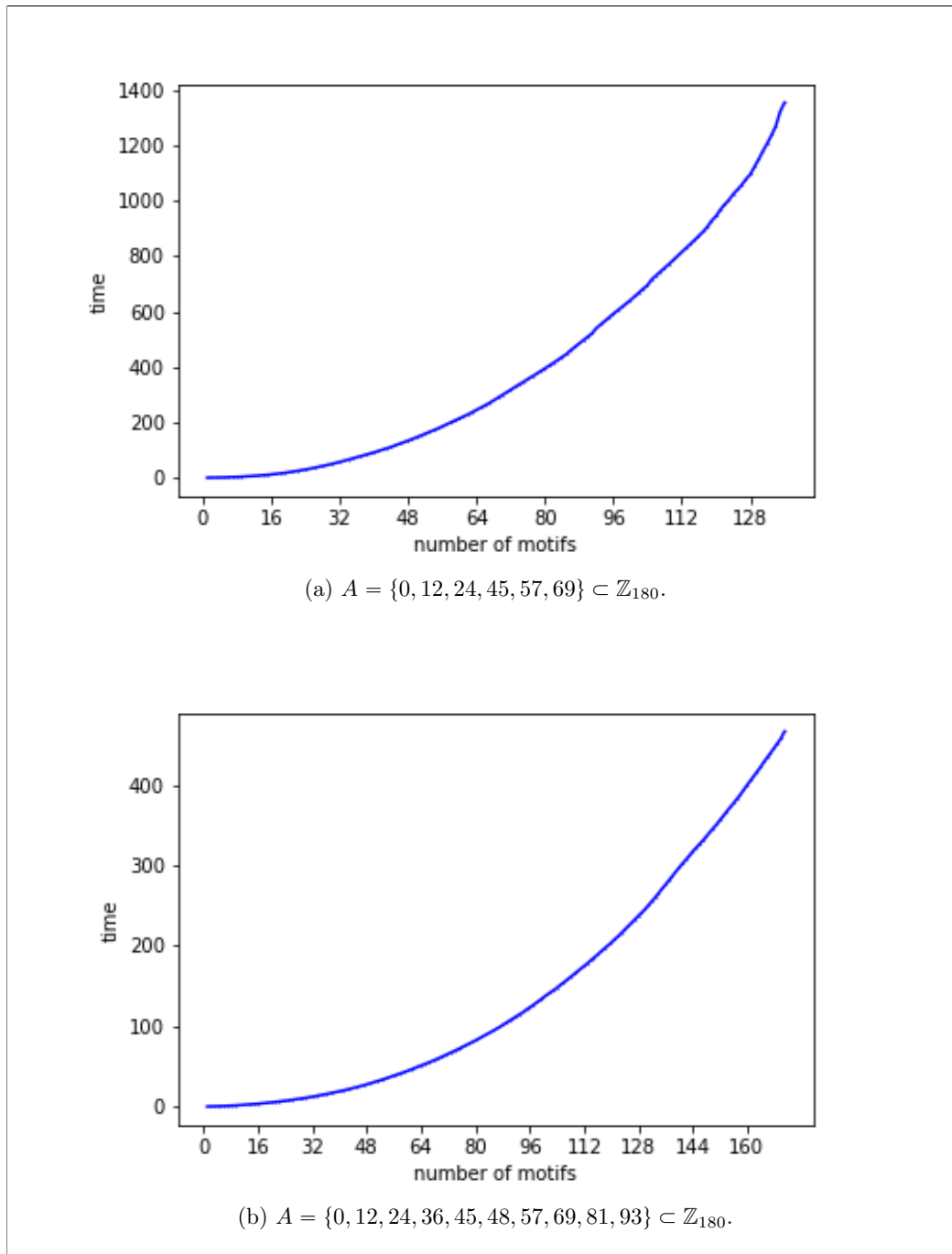
Before analyzing the tiling problem, let us introduce the SAT encoding, that is, the process of transforming a problem into a SAT problem. If such an assignment M exists, then it is said to satisfy B and we talk about a *model* of B .

A Boolean formula is in Conjunctive Normal Form (CNF) if the formula is a conjunction (s) of clauses where each clause is a disjunction (or) of literals and each literal is a propositional variable or the negation of a propositional variable. There has been a great deal of effort in devising techniques and creating tools for solving SAT problems, that is, to determine if a CNF formula is satisfactory and to identify the model of the formula. We refer to tools such as SAT solvers. Satisfiability is interesting as any problem can be coded as a CNF formula and a SAT solver can be used to solve the corresponding SAT problem.

We define two sets of constraints:

1. the *tiling constraints* that impose the condition $A \oplus B = \mathbb{Z}_n$, and
2. the *aperiodicity constraints* that impose that the canon B is aperiodic.

4.4.1 Tiling constraints

Given the period n and the rhythm A , let $\mathbf{a} = [a_0, \dots, a_{n-1}]^T$ be its characteristic (column) vector, that is, $a_i = 1$ if and only if $i \in A$. Using vector \mathbf{a} we define the circulant matrix $T \in \{0, 1\}^{n \times n}$ of rhythm A , that is, each column of T is the circular shift

of the first column, which corresponds to vector \mathbf{a} . Thus, the matrix T is equal to

$$T = \begin{bmatrix} a_0 & a_{n-1} & a_{n-2} & \cdots & a_1 \\ a_1 & a_0 & a_{n-1} & \cdots & a_2 \\ \vdots & \vdots & \vdots & \ddots & \vdots \\ a_{n-1} & a_{n-2} & a_{n-3} & \cdots & a_0 \end{bmatrix}.$$

We can use the circulant matrix T to impose the tiling conditions as follows. Let us introduce a literal x_i for $i = 0, \dots, n-1$, that represents the characteristic vector of the tiling rhythm B , that is, $x_i = 1$ if and only if $i \in B$. Note that a literal is equivalent to a 0–1 variable in ILP terminology. Then, the tiling condition can be written with the following linear constraint:

$$\sum_{i \in \{0, \dots, n-1\}} T_{ij} x_i = 1, \quad \forall j = 0, \dots, n-1. \quad (4.23)$$

Notice that the set of linear constraints (4.23) imposes that exactly one variable (literal) in the set $\{x_{n+i-j \bmod n}\}_{j \in A}$ is equal to one. Hence, we encode this condition as an **Exactly-one** constraint, that is, exactly one literal can take the value one. The **Exactly-one** constraint can be expressed as the conjunction of the two constraints **At-least-one** and **At-most-one**, for which standard SAT encoding exist (e.g., see [7, 24]). Hence, the tiling constraints (4.23) are encoded with the following set of clauses depending on $i = 0, \dots, n-1$:

$$\bigvee_{j \in A} (x_{n-(j-i) \bmod n}) \bigwedge_{k, l \in A, k \neq l} (\neg x_{n-(k-i) \bmod n} \vee \neg x_{n-(l-i) \bmod n}). \quad (4.24)$$

4.4.2 Aperiodicity constraints

In view of Definition 7, if there exists a $b \in B$ such that $(d+b) \bmod n \neq b$, then the canon B is not periodic modulo d . Notice that by Remark 5 we need to check this condition only for the values of $d \in \mathcal{D}_n$.

We formulate the aperiodicity constraints introducing auxiliary variables $y_{d,i}$, $z_{d,i}$, $u_{d,i} \in \{0, 1\}$ for every prime divisor $d \in \mathcal{D}_n$ and for every integer $i = 0, \dots, d-1$. We set

$$u_{d,i} = 1 \Leftrightarrow \left(\sum_{k=0}^{n/d-1} x_{i+kd} = \frac{n}{d} \right) \vee \left(\sum_{k=0}^{n/d-1} x_{i+kd} = 0 \right), \quad (4.25)$$

for all $d \in \mathcal{D}_n$, $i = 0, \dots, d-1$, with the condition

$$\sum_{i=0}^{d-1} u_{d,i} \leq d-1, \quad \forall d \in \mathcal{D}_n. \quad (4.26)$$

Similarly to [6], the constraints (4.25) can be linearized using standard reformulation techniques as follows:

$$0 \leq \sum_{k=0}^{n/d} x_{i+kd} - \frac{n}{d} y_{d,i} \leq \frac{n}{d} - 1 \quad \forall d \in \mathcal{D}_n, \quad i = 0, \dots, d-1, \quad (4.27)$$

$$0 \leq \sum_{k=0}^{n/d} (1 - x_{i+kd}) - \frac{n}{d} z_{d,i} \leq \frac{n}{d} - 1 \quad \forall d \in \mathcal{D}_n, \quad i = 0, \dots, d-1, \quad (4.28)$$

$$y_{d,i} + z_{d,i} = u_{d,i} \quad \forall d \in \mathcal{D}_n, \quad i = 0, \dots, d-1. \quad (4.29)$$

Notice that when $u_{d,i} = 1$ exactly one of the two incompatible alternatives in the right hand side of (4.25) is true, while whenever $u_{d,i} = 0$ the two constraints are false. Correspondingly, the constraint (4.29) imposes that the variables $y_{d,i}$ and $z_{d,i}$ cannot be equal to 1 at the same time. On the other hand, constraint (4.26) imposes that at least one of the auxiliary variables $u_{d,i}$ be equal to zero.

Next, we encode the previous conditions as a SAT formula. To encode the if and only if clause, we make use of the logical equivalence between $C_1 \Leftrightarrow C_2$ and $(\neg C_1 \vee C_2) \wedge (C_1 \vee \neg C_2)$. The clause C_1 is given directly by the literal $u_{d,i}$. The clause C_2 , expressing the right hand side of (4.25), i.e. the constraint that the variables must be either all true or all false, can be written as

$$C_2 = \left(\bigwedge_{k=0}^{n/d} x_{i+kd} \right) \vee \left(\bigwedge_{k=0}^{n/d} \bar{x}_{i+kd} \right), \quad \forall d \in \mathcal{D}_n.$$

Then, the linear constraint (4.26) can be stated as the SAT formula:

$$\neg (u_{d,0} \wedge u_{d,1} \wedge \dots \wedge u_{d,(d-1)}) = \bigvee_{l=0}^{d-1} \bar{u}_{d,l}, \quad \forall d \in \mathcal{D}_n.$$

Finally, we express the aperiodicity constraints using

$$\bigwedge_{i=0}^{d-1} [(\neg C_2 \vee u_{d,i}) \wedge (C_2 \vee \bar{u}_{d,i})] \wedge \bigvee_{l=0}^{d-1} \bar{u}_{d,l}, \quad \forall d \in \mathcal{D}_n. \quad (4.30)$$

Note that joining (4.23), (4.27)–(4.29) with a constant objective function gives a complete ILP Model, which can be solved with a modern ILP solver such as Gurobi to enumerate all possible solutions. At the same time, joining (4.24) and (4.30) into a unique CNF formula, we get our complete SAT encoding of the Aperiodic Tiling Complements Problem.

4.4.3 Computational results

First, we compare the results obtained using our ILP model and SAT encoding with the runtimes of the *Fill-Out Procedure* and of the *CS Algorithm*. We use the canons with

Table 4.3: Aperiodic tiling complements for periods $n \in \{72, 108, 120, 144, 168\}$.

n	p_1	n_1	p_2	n_2	n_3	runtimes (s)				# B
						FOP	CSA	SAT	ILP	
72	2	2	3	3	2	1.59	0.10	< 0.01	0.03	6
108	2	2	3	3	3	896.06	7.84	0.09	0.19	252
120	2	2	5	3	2	24.16	0.27	0.02	0.04	18
	2	2	3	5	2	10.92	0.14	0.01	0.04	20
144	4	2	3	3	2	82.53	2.93	0.02	0.11	36
	2	2	3	3	4	> 10800.00	> 10800.00	11.04	46.96	8640
	2	2	3	3	4	7.13	0.10	< 0.01	0.05	6
	2	4	3	3	2	80.04	0.94	0.02	0.08	60
168	2	2	7	3	2	461.53	17.61	0.04	0.20	54
	2	2	3	7	2	46.11	0.91	0.02	0.07	42

periods 72, 108, 120, 144 and 168 that have been completely enumerated by Vuza [29], Friperntinger [12], Amiot [2], Kolountzakis and Matolcsi [21]. Table 4.3 shows clearly that the two new approaches outperform the state-of-the-art, and in particular, that SAT provides the best solution approach. We then choose some periods n with more complex prime factorisations, such as $n = p^2q^2r = 180$, $n = p^2qrs = 420$, and $n = p^2q^2r^2 = 900$. To find aperiodic rhythms A , we apply Vuza's construction [29] with different choices of parameters p_1, p_2, n_1, n_2, n_3 . Thus, having n and A as inputs, we search for all the possible aperiodic complements and then we filter out the solutions under translation. Since the post-processing is based on sorting canons, it requires a comparatively small amount of time. We report the results in Table 4.4: the solution approach based on the SAT encoding is the clear winner. It is also noteworthy that, from a Music theory perspective, this is the first time that all the tiling complements of the studied rhythms are computed (their number is reported in the last column of the two tables).

Implementation Details

We have implemented in Python the ILP model and in PySat [17] the SAT encoding discussed in 4.3. We use Gurobi 9.1.1 as ILP solver and Maplesat [23] as SAT solver. The experiments are run on a Dell Workstation with a Intel Xeon W-2155 CPU with 10 physical cores at 3.3GHz and 32 GB of RAM.

Table 4.4: Aperiodic tiling complements for periods $n \in \{180, 420, 900\}$.

n	\mathcal{D}_n	p_1	n_1	p_2	n_2	n_3	runtimes (s)		# B
							<i>SAT</i>	<i>ILP</i>	
180	{36, 60, 90}	2	2	5	3	3	2.57	5.62	2052
		3	3	5	2	2	0.07	0.14	96
		2	2	3	5	3	1.25	2.23	1800
		2	5	3	3	2	0.05	0.16	120
		2	2	3	3	5	8079.07	> 10800.00	281232
420	{60, 84, 140, 210}	7	5	3	2	2	2.13	3.57	720
		5	7	3	2	2	1.52	4.08	672
		7	5	2	3	2	7.73	16.11	3120
		5	7	2	3	2	1.63	4.18	1008
		7	3	5	2	2	4.76	7.45	864
		3	7	5	2	2	12.78	32.19	6720
		7	3	2	5	2	107.83	1186.21	33480
		3	7	2	5	2	0.73	2.36	840
		7	2	5	3	2	11.14	21.19	1872
		2	7	5	3	2	17.31	52.90	10080
		7	2	3	5	2	89.97	691.56	22320
2	7	3	5	2	1.17	4.13	1120		
900	{180, 300, 450}	2	25	3	3	2	43.60	110.65	15600
		5	10	3	3	2	107.36	741.79	15840
		2	9	5	5	2	958.58	> 10800.00	118080
		6	3	5	5	2	5559.76	> 10800.00	123840
		3	6	5	5	2	486.39	8290.35	62160

4.5 Enumerating aperiodic canons

As pointed out by E. Amiot in [3], an application of the Coven-Meyerowitz completion formula in Proposition 9 is part of an algorithm (due to M. Matolcsi [21, 5]), designed to catalogue the aperiodic canons in a given non-Hajós group \mathbb{Z}_n . This algorithm allowed to check the Fripertinger results for $n = 72$ and $n = 108$ and to complete the catalogue for $n = 120$, $n = 144$, and $n = 168$. The idea is to check all possible S_A sets. In light of the good performance of the *SAT Encoding Algorithm*, it could be proposed to use it to search for all the possible aperiodic complements of a given rhythm with a given period.

1. Compute all partitions into two subsets of the set of prime power divisors of n . Keep (usually) the smaller part, which will be S_A (the other will obviously be S_B).
2. Discard all the partitions that produce only periodic tilings due to condition (T2), eliminating all sets R_A that either
 - make sure that A is periodic, or
 - make sure that B must be periodic (remembering that R_B must contain at least all the divisors of n not in R_A).
3. Compute the Coven-Meyerowitz complement B_{CM} for S_A .
4. Find all possible A by completing B_{CM} , using the *SAT Encoding Algorithm*. Sort by the different R_A values, keeping a representative for each possibility.
5. For each remaining representative of possible A 's, compute B 's complements with the *SAT Encoding Algorithm*, discarding periodic ones.
6. Whatever remains is an aperiodic canon.

4.5.1 The cases $n = 180$ and $n = 200$

Let us now apply the algorithm described above and try to complete the enumeration of the aperiodic canons of period 180.

1. The prime powers that divide 180 are 2, 4, 3, 9, and 5. In any tiling $A \oplus B = \mathbb{Z}_{180}$ the cyclotomic polynomials corresponding to these prime powers must divide exactly one of $A(x)$ and $B(x)$, according to condition (T1) of [9]. There are 15 possible

partitions $\{H^A, H^B\}$ of the elements $\{2, 4, 3, 9, 5\}$. The partitions are:

$$\begin{array}{ll}
\{\{2, 4\}, \{3, 9, 5\}\}, & \{\{2\}, \{4, 3, 9, 5\}\}, \\
\{\{2, 3\}, \{4, 9, 5\}\}, & \{\{4\}, \{2, 3, 9, 5\}\}, \\
\{\{2, 9\}, \{4, 3, 5\}\}, & \{\{3\}, \{2, 4, 9, 5\}\}, \\
\{\{2, 5\}, \{4, 3, 9\}\}, & \{\{9\}, \{2, 4, 3, 5\}\}, \\
\{\{4, 3\}, \{2, 9, 5\}\}, & \{\{5\}, \{2, 4, 3, 9\}\}, \\
\{\{4, 9\}, \{2, 3, 5\}\}, & \\
\{\{4, 5\}, \{2, 3, 9\}\}, & \\
\{\{3, 9\}, \{2, 4, 5\}\}, & \\
\{\{3, 5\}, \{2, 4, 9\}\}, & \\
\{\{9, 5\}, \{2, 4, 3\}\}. &
\end{array}$$

2. No partition produces periodic tilings due to condition (T2) of [9]. Therefore, in this step, we can not discard any case.
3. We list out all subsets $B_{CM} \subset \mathbb{Z}_{180}$ such that B_{CM} tiles \mathbb{Z}_{180} and $\Phi_h(x)$ divides $B_{CM}(x)$ for all $h \in H^{B_{CM}}$:

$$\begin{array}{ll}
(20\mathbb{I}_3 \oplus 60\mathbb{I}_3 \oplus 36\mathbb{I}_5), & (45\mathbb{I}_2 \oplus 20\mathbb{I}_3 \oplus 60\mathbb{I}_3 \oplus 36\mathbb{I}_5), \\
(90\mathbb{I}_2 \oplus 60\mathbb{I}_3 \oplus 36\mathbb{I}_5), & (90\mathbb{I}_2 \oplus 20\mathbb{I}_3 \oplus 60\mathbb{I}_3 \oplus 36\mathbb{I}_5), \\
(90\mathbb{I}_2 \oplus 20\mathbb{I}_3 \oplus 36\mathbb{I}_5), & (45\mathbb{I}_2 \oplus 90\mathbb{I}_2 \oplus 60\mathbb{I}_3 \oplus 36\mathbb{I}_5), \\
(90\mathbb{I}_2 \oplus 20\mathbb{I}_3 \oplus 60\mathbb{I}_3), & (45\mathbb{I}_2 \oplus 90\mathbb{I}_2 \oplus 20\mathbb{I}_3 \oplus 36\mathbb{I}_5), \\
(45\mathbb{I}_2 \oplus 60\mathbb{I}_3 \oplus 36\mathbb{I}_5), & (45\mathbb{I}_2 \oplus 90\mathbb{I}_2 \oplus 20\mathbb{I}_3 \oplus 60\mathbb{I}_3), \\
(45\mathbb{I}_2 \oplus 20\mathbb{I}_3 \oplus 36\mathbb{I}_5), & \\
(45\mathbb{I}_2 \oplus 20\mathbb{I}_3 \oplus 60\mathbb{I}_3), & \\
(45\mathbb{I}_2 \oplus 90\mathbb{I}_2 \oplus 36\mathbb{I}_5), & \\
(45\mathbb{I}_2 \oplus 90\mathbb{I}_2 \oplus 60\mathbb{I}_3), & \\
(45\mathbb{I}_2 \oplus 90\mathbb{I}_2 \oplus 20\mathbb{I}_3). &
\end{array}$$

4. We search all possible A 's by completing the B_{CM} 's using the *SAT Encoding Algorithm* and keep a representative for each possible R_A value (represented in Figure

4.4:

$$R_A = \{\mathbf{2}, \mathbf{3}, 6, 10, 12, 15, 18, 30, 60, 90\},$$

$$A = \{0, 20, 40, 45, 65, 85\},$$

$$R_A = \{\mathbf{2}, \mathbf{9}, 6, 10, 18, 30, 36, 90\},$$

$$A = \{0, 12, 24, 45, 57, 69\},$$

$$R_A = \{\mathbf{4}, \mathbf{3}, 6, 12, 15, 30, 36, 60\},$$

$$A = \{0, 18, 20, 38, 40, 58\},$$

$$R_A = \{\mathbf{2}, \mathbf{5}, 6, 10, 15, 18, 20, 30, 60, 90\},$$

$$A = \{0, 12, 24, 36, 45, 48, 57, 69, 81, 93\},$$

$$R_A = \{\mathbf{3}, \mathbf{5}, 6, 10, 12, 15, 30, 45, 60, 90\},$$

$$A = \{0, 18, 20, 36, 38, 40, 54, 56, 58, 72, 74, 76, 92, 94, 112\}.$$

5. For each representative of possible A 's found in the previous step, we then compute complements B discarding periodic ones. The possible R_B are the following:

$$R_B = \{\mathbf{4}, \mathbf{9}, \mathbf{5}, 6, 12, 18, 20, 36, 45, 180\},$$

$$R_B = \{\mathbf{4}, \mathbf{9}, \mathbf{5}, 6, 12, 20, 36, 45, 180\},$$

$$R_B = \{\mathbf{4}, \mathbf{9}, \mathbf{5}, 6, 18, 20, 36, 45, 180\},$$

$$R_B = \{\mathbf{4}, \mathbf{9}, \mathbf{5}, 6, 20, 36, 45, 180\},$$

$$R_B = \{\mathbf{4}, \mathbf{9}, \mathbf{5}, 12, 18, 20, 36, 45, 180\},$$

$$R_B = \{\mathbf{4}, \mathbf{9}, \mathbf{5}, 12, 20, 36, 45, 180\},$$

$$R_B = \{\mathbf{4}, \mathbf{9}, \mathbf{5}, 18, 20, 36, 45, 180\},$$

$$R_B = \{\mathbf{4}, \mathbf{9}, \mathbf{5}, 20, 36, 45, 180\},$$

$$R_B = \{\mathbf{4}, \mathbf{3}, \mathbf{5}, 10, 12, 15, 20, 45, 60, 180\},$$

$$R_B = \{\mathbf{4}, \mathbf{3}, \mathbf{5}, 12, 15, 20, 45, 60, 180\},$$

$$R_B = \{\mathbf{2}, \mathbf{9}, \mathbf{5}, 10, 18, 20, 45, 90, 180\},$$

$$R_B = \{\mathbf{4}, \mathbf{3}, \mathbf{9}, 12, 36, 45\},$$

$$R_B = \{\mathbf{2}, \mathbf{4}, \mathbf{9}, 18, 20, 36, 180\}.$$

6. It turns out that the aperiodic canons we get at the end of the research are exactly the extended Vuza canons of period 180. Note that all the aperiodic rhythms B such

that R_B is one of the 8 types including $S_B = \{4, 9, 5\}$ tile with aperiodic rhythms A such that $R_A = \{2, 3, 6, 10, 12, 15, 18, 30, 60, 90\}$. This means that elements 6, 12, 18 in those R_B 's can be considered indices of *non-necessary cyclotomic polynomials* dividing $B(x)$. Similarly, the aperiodic rhythms B such that R_B is one of the 2 types including $S_B = \{4, 3, 5\}$ tile with aperiodic rhythms A such that $R_A = \{2, 9, 6, 10, 18, 30, 36, 90\}$, and so 10 in those R_B 's is the index of a non-necessary cyclotomic polynomial.

Remark 9. As pointed out by E. Amiot in [3] and as can be verified applying Matolcsi's algorithm described above, the necessity of condition (T2) also holds for all aperiodic rhythms in \mathbb{Z}_{180} .

The order of the next non-Hajós group is $n = 200$. It is a simple case in which $n = p^3 q^2$, with p and q primes; then, we are also sure that condition (T2) is necessary for tiling, for all rhythms in \mathbb{Z}_{200} . Therefore, from the point of view of the construction of extended Vuza canons, this case is analogous to $n = 72$ and $n = 108$ (see Figure 4.5).

Applying Matolcsi's algorithm in combination with the *SAT Encoding Algorithm*, we found also in this case that all the aperiodic canons possible with period 200 are exactly the extended Vuza canons of Chapter 3.

Remark 10. Thus, the catalogue of aperiodic canons is complete for all (non-Hajós) groups with order $n \leq 200$ and it coincides with Table 3.4.

4.5.2 The case $n = 900$ with $S_A = \{2, 3, 5\}$

As we have seen in Table 4.5 and in Table 4.6, the possible choices of the parameters p_1, n_1, p_2, n_2 , and n_3 for the period $n = 900$ are numerous and most of them provide an extremely high number of extended Vuza canons. At the moment, it is hard to verify the number of every combination of parameters through an algorithm for the exhaustive research of complements.

However, studying the partition $\{H^A, H^B\} = \{\{2, 3, 5\}, \{4, 9, 25\}\}$ of prime powers dividing 900, we were able to calculate the number of all aperiodic rhythms tiling with the Coven-Meyerowitz complement

$$A_{CM}(x) = \Phi_2(x^{225}) \Phi_3(x^{100}) \Phi_5(x^{36}).$$

The *SAT Encoding Algorithm* allowed us to compute the number of all tiling complements of A_{CM} , which turned out to be 303360. As underlined in Remark 4, A_{CM} can in this case be part of an extended Vuza canon as "inner rhythm" (the one for which $n \notin R_A$) according to the construction:

$$\begin{aligned} A &= A_1 \oplus A_2 \oplus \bar{L} \\ &= n_3 p_1 n_1 \tilde{A}_1 \oplus n_3 p_2 n_2 \tilde{A}_2 \oplus \bar{L}, \end{aligned}$$

where parameters p_1, n_1, p_2, n_2, n_3 and factors $\tilde{A}_1, \tilde{A}_2, \bar{L}$ are defined as in Chapter 3. In light of this, we have three possibilities.

Figure 4.4: $n = 180$.

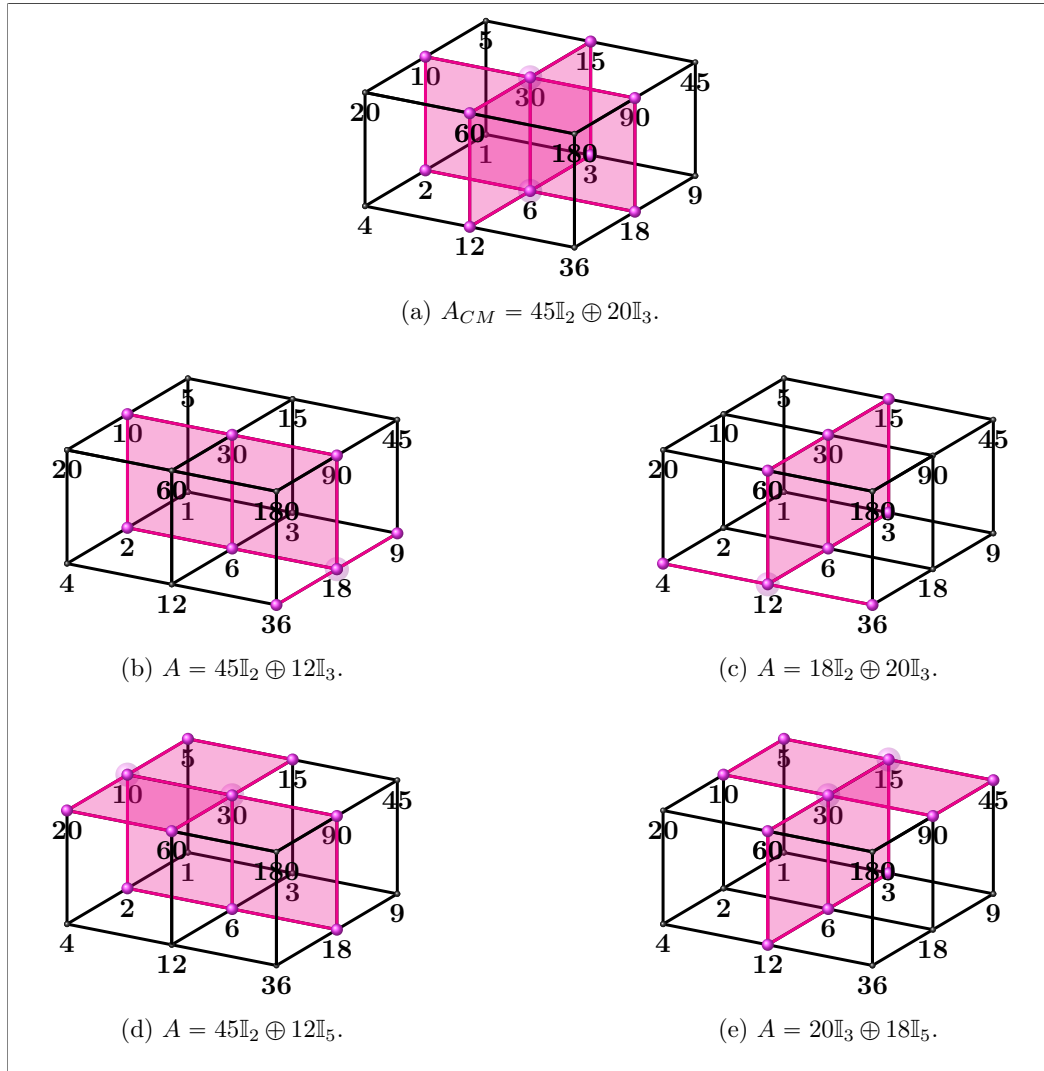

Lattice representations of all possible A 's for aperiodic canons of period $n = 180$.

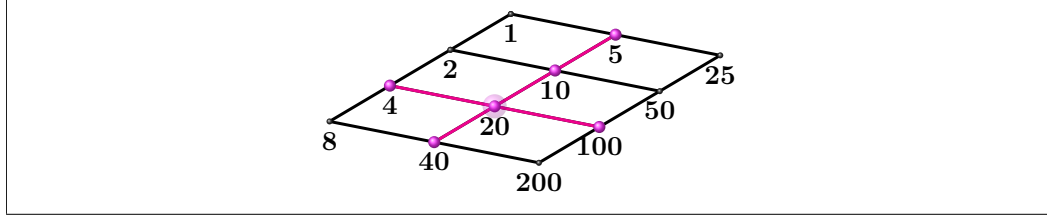
Figure 4.5: $n = 200$. $A_{CM} = 50\mathbb{I}_2 \oplus 8\mathbb{I}_3$.

Lattice representation of any rhythm A of any aperiodic tiling rhythmic canon with period $n = 200$.

1. $(p_1, n_1, p_2, n_2, n_3) = (2, 2, 3, 3, 25)$. $A_1 = 100\tilde{A}_1$, $A_2 = 225\tilde{A}_2$, $\bar{L} = 36\mathbb{I}_5$.
2. $(p_1, n_1, p_2, n_2, n_3) = (2, 2, 5, 5, 9)$. $A_1 = 36\tilde{A}_1$, $A_2 = 225\tilde{A}_2$, $\bar{L} = 100\mathbb{I}_3$.
3. $(p_1, n_1, p_2, n_2, n_3) = (3, 3, 5, 5, 4)$. $A_1 = 36\tilde{A}_1$, $A_2 = 100\tilde{A}_2$, $\bar{L} = 225\mathbb{I}_2$.

We compute the extended Vuza complements B 's in each case. Recall that

$$\begin{aligned} \#\tilde{V}_1 &= \frac{1}{p_2} \sum_{u|p_2} \mu\left(\frac{p_2}{u}\right) \left(n_1^{(u-1)} - 1\right) \\ \#\tilde{V}_2 &= \frac{1}{p_1} \sum_{v|p_1} \mu\left(\frac{p_1}{v}\right) \left(n_2^{(v-1)} - 1\right). \end{aligned}$$

1. $\#\tilde{V}_1 = 1$. $\#\tilde{V}_2 = 1$. $\#K = 5$. $|K| = 5$. $U_1 = 25 \cdot 2 \cdot 2 \cdot 3 \cdot \mathbb{I}_3$. $U_2 = 25 \cdot 3 \cdot 3 \cdot 2 \cdot \mathbb{I}_2$.

$$\begin{aligned} B &= \left(\left(U_1 \oplus 25 \cdot 2 \cdot \tilde{V}_2^1 \oplus \{k_1^1, \dots, k_1^{l_1}\} \right) \sqcup \dots \right. \\ &\quad \left. \dots \sqcup \left(U_1 \oplus 25 \cdot 2 \cdot \tilde{V}_2^j \oplus \{k_1^{l_{j-1}+1}, \dots, k_1^{|K_1|}\} \right) \right) \sqcup \\ &\quad \left(\left(U_2 \oplus 25 \cdot 3 \cdot \tilde{V}_1^1 \oplus \{k_2^1, \dots, k_2^{m_1}\} \right) \sqcup \dots \right. \\ &\quad \left. \dots \sqcup \left(U_2 \oplus 25 \cdot 3 \cdot \tilde{V}_1^h \oplus \{k_2^{m_{h-1}+1}, \dots, k_2^{|K_2|}\} \right) \right) \sqcup (25 \cdot 2 \cdot 3 \cdot \mathbb{I}_{2,3} \oplus K_3). \end{aligned}$$

The number of extended Vuza complements of A_{CM} in \mathbb{Z}_{900} is

$$\#B = \frac{\#K}{n} \sum_{1 \leq i \leq m} \left(n_1 p_2 n_2 \cdot \#\tilde{V}_1 \right)^{t_{i1}} \cdot \left(n_2 p_1 n_1 \cdot \#\tilde{V}_2 \right)^{t_{i2}} \cdot (n_1 n_2)^{t_{i3}} \cdot \binom{|K|}{\mathbf{t}_i} = 281232,$$

where (t_{i1}, t_{i2}, t_{i3}) , with $i = 1, \dots, m$, represents a possible partition of the remainder classes modulo $|K|$ of \mathbb{Z}_{900} .

2. $\#\tilde{V}_1 = 3$. $\#\tilde{V}_2 = 2$. $\#K = 3$. $|K| = 3$. $U_1 = 9 \cdot 2 \cdot 2 \cdot 5 \cdot \mathbb{I}_5$. $U_2 = 9 \cdot 5 \cdot 5 \cdot 2 \cdot \mathbb{I}_2$.

$$\begin{aligned} B = & \left((U_1 \oplus 9 \cdot 2 \cdot \tilde{V}_2^1 \oplus \{k_1^1, \dots, k_1^{l_1}\}) \sqcup \dots \right. \\ & \left. \dots \sqcup (U_1 \oplus 9 \cdot 2 \cdot \tilde{V}_2^j \oplus \{k_1^{l_{j-1}+1}, \dots, k_1^{|K_1|}\}) \right) \sqcup \\ & \left((U_2 \oplus 9 \cdot 5 \cdot \tilde{V}_1^1 \oplus \{k_2^1, \dots, k_2^{m_1}\}) \sqcup \dots \right. \\ & \left. \dots \sqcup (U_2 \oplus 9 \cdot 5 \cdot \tilde{V}_1^h \oplus \{k_2^{m_{h-1}+1}, \dots, k_2^{|K_2|}\}) \right) \sqcup (9 \cdot 2 \cdot 5 \cdot \mathbb{I}_{2 \cdot 5} \oplus K_3). \end{aligned}$$

Similarly to the previous case, the number of extended Vuza complements of A_{CM} in \mathbb{Z}_{900} is $\#B = 12600$.

3. $\#\tilde{V}_1 = 16$. $\#\tilde{V}_2 = 8$. $\#K = 2$. $|K| = 2$. $U_1 = 4 \cdot 3 \cdot 3 \cdot 5 \cdot \mathbb{I}_5$. $U_2 = 4 \cdot 5 \cdot 5 \cdot 3 \cdot \mathbb{I}_3$.

$$\begin{aligned} B = & \left((U_1 \oplus 4 \cdot 3 \cdot \tilde{V}_2^1 \oplus \{k_1^1, \dots, k_1^{l_1}\}) \sqcup \dots \right. \\ & \left. \dots \sqcup (U_1 \oplus 4 \cdot 3 \cdot \tilde{V}_2^j \oplus \{k_1^{l_{j-1}+1}, \dots, k_1^{|K_1|}\}) \right) \sqcup \\ & \left((U_2 \oplus 4 \cdot 5 \cdot \tilde{V}_1^1 \oplus \{k_2^1, \dots, k_2^{m_1}\}) \sqcup \dots \right. \\ & \left. \dots \sqcup (U_2 \oplus 4 \cdot 5 \cdot \tilde{V}_1^h \oplus \{k_2^{m_{h-1}+1}, \dots, k_2^{|K_2|}\}) \right). \end{aligned}$$

The number of extended Vuza complements of A_{CM} in \mathbb{Z}_{900} is $\#B = 1920$.

It is interesting to note that the number of extended Vuza complements for each of the three individual cases for $n = 900$ analyzed above, corresponds to the number of extended Vuza complements of $A'_{CM} = n'_3 p_1 n_1 \tilde{A}_1 \oplus n'_3 p_2 n_2 \tilde{A}_2$ for a new period $n' = p_1 n_1 p_2 n_2 n'_3$ such that $n'_3 = n_3/\alpha$ and $\alpha = |\bar{L}| = n_3/|K|$. Let us see how to construct the Vuza complements respectively in the cases $n' = 900/5$, $n' = 900/3$, and $n' = 900/2$. Note, first of all, that $\#\tilde{V}_1$ and $\#\tilde{V}_2$ will not change, since they are independent of the parameter n_3 .

1. $\#\tilde{V}_1 = 1$. $\#\tilde{V}_2 = 1$. $K' = \mathbb{Z}_5$. $U'_1 = 5 \cdot 2 \cdot 2 \cdot 3 \cdot \mathbb{I}_3$. $U'_2 = 5 \cdot 3 \cdot 3 \cdot 2 \cdot \mathbb{I}_2$.

$$\begin{aligned} B' = & \left((U'_1 \oplus 5 \cdot 2 \cdot \tilde{V}_2^1 \oplus \{k_1^1, \dots, k_1^{l_1}\}) \sqcup \dots \right. \\ & \left. \dots \sqcup (U'_1 \oplus 5 \cdot 2 \cdot \tilde{V}_2^j \oplus \{k_1^{l_{j-1}+1}, \dots, k_1^{|K_1|}\}) \right) \sqcup \\ & \left((U'_2 \oplus 5 \cdot 3 \cdot \tilde{V}_1^1 \oplus \{k_2^1, \dots, k_2^{m_1}\}) \sqcup \dots \right. \\ & \left. \dots \sqcup (U'_2 \oplus 5 \cdot 3 \cdot \tilde{V}_1^h \oplus \{k_2^{m_{h-1}+1}, \dots, k_2^{|K_2|}\}) \right) \sqcup (5 \cdot 2 \cdot 3 \cdot \mathbb{I}_{2 \cdot 3} \oplus K_3). \end{aligned}$$

The number of extended Vuza complements of A'_{CM} in \mathbb{Z}_{180} is

$$\#B' = \frac{1}{\alpha} \sum_{1 \leq i \leq m} (n_1 p_2 n_2 \cdot \#\tilde{V}_1)^{t_{i1}} \cdot (n_2 p_1 n_1 \cdot \#\tilde{V}_2)^{t_{i2}} \cdot (n_1 n_2)^{t_{i3}} \cdot \binom{n_3/\alpha}{\mathbf{t}_i} = 281232,$$

where (t_{i1}, t_{i2}, t_{i3}) , with $i = 1, \dots, m$, represents a possible partition of the remainder classes modulo $|K'| = n'_3 = |K|$ of \mathbb{Z}_{180} (see Figure 4.6).

2. $\#\tilde{V}_1 = 3$. $\#\tilde{V}_2 = 2$. $K' = \mathbb{Z}_3$. $U'_1 = 3 \cdot 2 \cdot 2 \cdot 2 \cdot 5 \cdot \mathbb{I}_5$. $U'_2 = 3 \cdot 5 \cdot 5 \cdot 2 \cdot \mathbb{I}_2$.

$$\begin{aligned} B' = & \left(\left(U'_1 \oplus 3 \cdot 2 \cdot \tilde{V}_2^1 \oplus \{k_1^1, \dots, k_1^{l_1}\} \right) \sqcup \dots \right. \\ & \left. \dots \sqcup \left(U'_1 \oplus 3 \cdot 2 \cdot \tilde{V}_2^j \oplus \{k_1^{l_{j-1}+1}, \dots, k_1^{|K_1|}\} \right) \right) \sqcup \\ & \left(\left(U'_2 \oplus 3 \cdot 5 \cdot \tilde{V}_1^1 \oplus \{k_2^1, \dots, k_2^{m_1}\} \right) \sqcup \dots \right. \\ & \left. \dots \sqcup \left(U'_2 \oplus 3 \cdot 5 \cdot \tilde{V}_1^h \oplus \{k_2^{m_{h-1}+1}, \dots, k_2^{|K_2|}\} \right) \right) \sqcup (3 \cdot 2 \cdot 5 \cdot \mathbb{I}_{2 \cdot 5} \oplus K_3). \end{aligned}$$

The number of extended Vuza complements of A'_{CM} in \mathbb{Z}_{300} is therefore $\#B' = 12600$ (see Figure 4.7).

3. $\#\tilde{V}_1 = 16$. $\#\tilde{V}_2 = 8$. $K' = \mathbb{Z}_2$. $U'_1 = 2 \cdot 3 \cdot 3 \cdot 5 \cdot \mathbb{I}_5$. $U'_2 = 2 \cdot 5 \cdot 5 \cdot 3 \cdot \mathbb{I}_3$.

$$\begin{aligned} B' = & \left(\left(U'_1 \oplus 2 \cdot 3 \cdot \tilde{V}_2^1 \oplus \{k_1^1, \dots, k_1^{l_1}\} \right) \sqcup \dots \right. \\ & \left. \dots \sqcup \left(U'_1 \oplus 2 \cdot 3 \cdot \tilde{V}_2^j \oplus \{k_1^{l_{j-1}+1}, \dots, k_1^{|K_1|}\} \right) \right) \sqcup \\ & \left(\left(U'_2 \oplus 2 \cdot 5 \cdot \tilde{V}_1^1 \oplus \{k_2^1, \dots, k_2^{m_1}\} \right) \sqcup \dots \right. \\ & \left. \dots \sqcup \left(U'_2 \oplus 2 \cdot 5 \cdot \tilde{V}_1^h \oplus \{k_2^{m_{h-1}+1}, \dots, k_2^{|K_2|}\} \right) \right). \end{aligned}$$

The number of extended Vuza complements of A'_{CM} in \mathbb{Z}_{450} is $\#B' = 1920$ (see Figure 4.8).

What we have seen is the effect of \bar{n}_3 -operation applied to a Vuza canon of period $p_1 n_1 p_2 n_2 n_3$ to get an extended Vuza canon of period $p_1 n_1 p_2 n_2 (\theta n_3)$, in combination with the addition of an appropriate set \bar{L} that makes the cardinalities of the old and new sets K identical. Note that the number of all tiling sets with $\bar{L} = r\mathbb{I}_s$ (s prime) in \mathbb{Z}_{n_3} is s^r .

Remark 11. Finally, note that the extended Vuza motifs B tiling in \mathbb{Z}_{900} with $A_{CM} = n_3 p_1 n_1 \tilde{A}_1 \oplus n_3 p_2 n_2 \tilde{A}_2 \oplus \bar{L}$ (such that $S_{\tilde{A}} = \{2, 3, 5\}$ and \bar{L} is an extension of L), are the same B 's tiling with A 's which differ only for different extensions of L (see Figures (b), (c), (d), and (e) in Figures 4.6, 4.7, and 4.8). The reason lies in the fact that the three summands of $B(x)$ always have in common all the cyclotomic factors with indices greater than n_3 which are not factors of $A(x)$, whatever $K(x)$. Therefore, in our case, all cyclotomic polynomials with indices multiple of $q \mid n_3$ and not of n_3 are always divisors of $B(x)$.

Let us now go back to the 303360 aperiodic tiling complements calculated with the *SAT Encoding Algorithm*. The sum of the extended Vuza complements of the same A_{CM} turns out to be $281232 + 12600 + 1920 = 295752 < 303360$. Our attention is then drawn to the 7608 exceeding rhythms. It is easy to prove that these rhythms have characteristic polynomials with factorisations in cyclotomic polynomials that cannot be

achieved through the Vuza construction, nor the extended Vuza algorithm. The set R_B for all these 7608 rhythms is in fact given by

$$R_B = \{4, 9, 25, 36, 100, 225, 900\},$$

which does not correspond to any extended Vuza rhythm as pointed out in Remark 11. Note that condition (T2) holds also for these rhythms.

A nice characteristic is that there is no *equirepartition* of any of them modulo some divisor of n ; that is to say when (w.l.o.g.), the rhythm is not divisible by some t . Lagarias and Szabo, in [1], were the first who exhibited tilings which have this feature. In fact, they found the smallest known aperiodic canon without equirepartition for $n = 900$, and the outer rhythm of this canon is one of the 7608 aperiodic rhythm we are talking about. In Figure 4.9, the lattice of the 7608 aperiodic with no equirepartition rhythms is represented: it consists of 8 vertices of the lattice cube of 900 (all except, of course, vertex 1).

In their paper Lagarias and Szabo pointed out that the rhythm they found, although less regular than others, gives rise anyway to a *quasiperiodic* canon (i.e. a canon of the form $A \oplus B = \mathbb{Z}_n$ such that there exists a subgroup $H = \{h_1 = 0, h_2, \dots\}$ and a partition $B = \cup B_i$ with $A + B_1 + h_i = A + B_i$). In their case, $H = \{0, 300, 600\}$.

The quasi-periodicity conjecture, originally made by Hajós, states that every canon is in fact quasi-periodic (because either A or B admits the above type f partition).

It is worth noting that all 7608 complements (the one found by Lagarias and Szabo included) admit a partition as in the above definition, and are thus quasi-periodic, with respect to each of the 3 possible subgroups $H_2 = \{0, 450\}$, $H_3 = \{0, 300, 600\}$, and $H_5 = \{0, 180, 360, 540, 720\}$. Indeed, they usually admit several such partitions; they therefore offer no counterexample against the quasi-periodicity conjecture.

Figure 4.6: $n = 900$. $A_1 \oplus A_2 = 45\mathbb{I}_2 \oplus 20\mathbb{I}_3$.

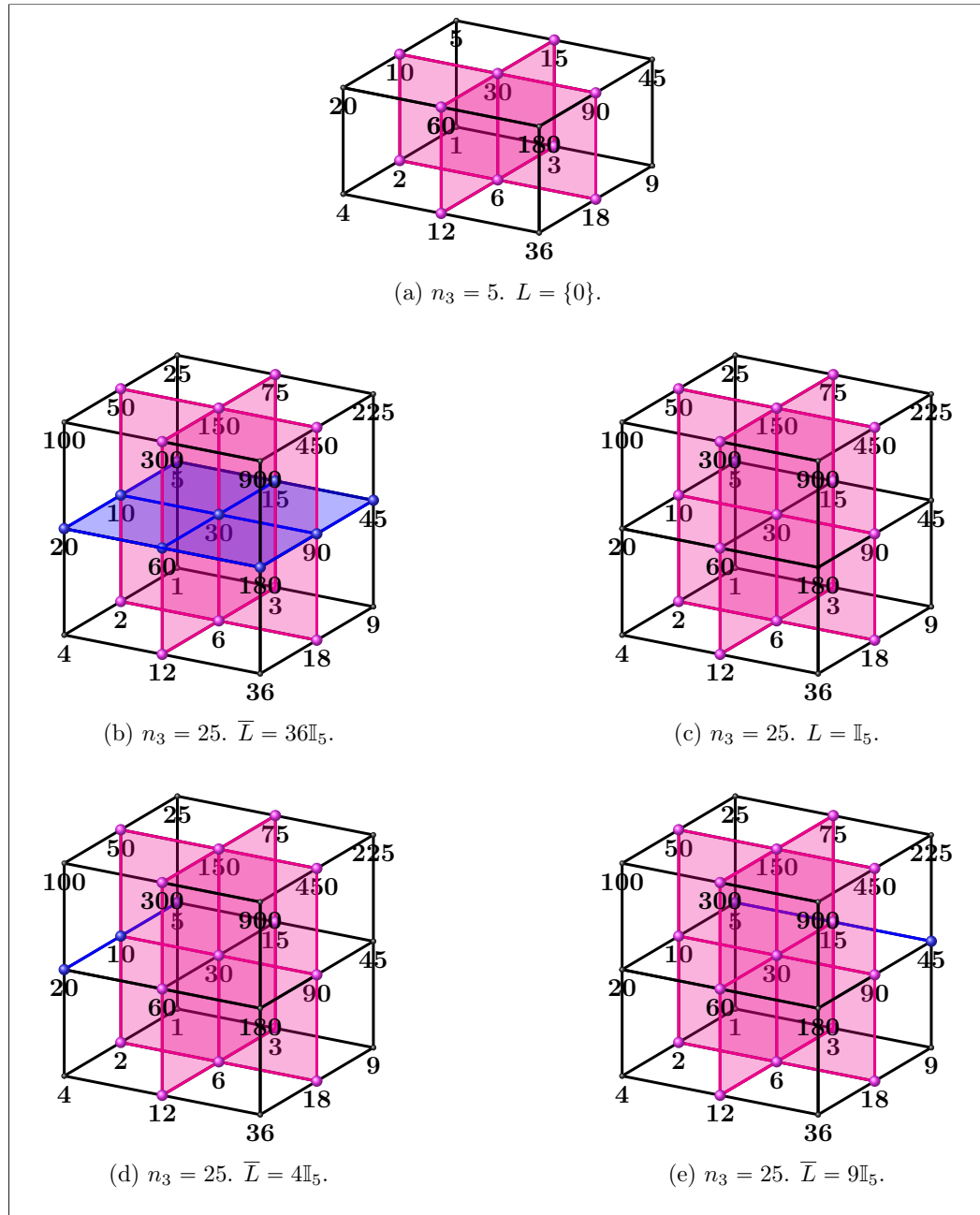

Lattice representations of tiling complements of the 281232 extended Vuza rhythms for $p_1 = 2$, $n_1 = 2$, $p_2 = 3$, and $n_2 = 3$.

Figure 4.7: $n = 900$. $A_1 \oplus A_2 = 225\mathbb{I}_2 \oplus 36\mathbb{I}_5$.

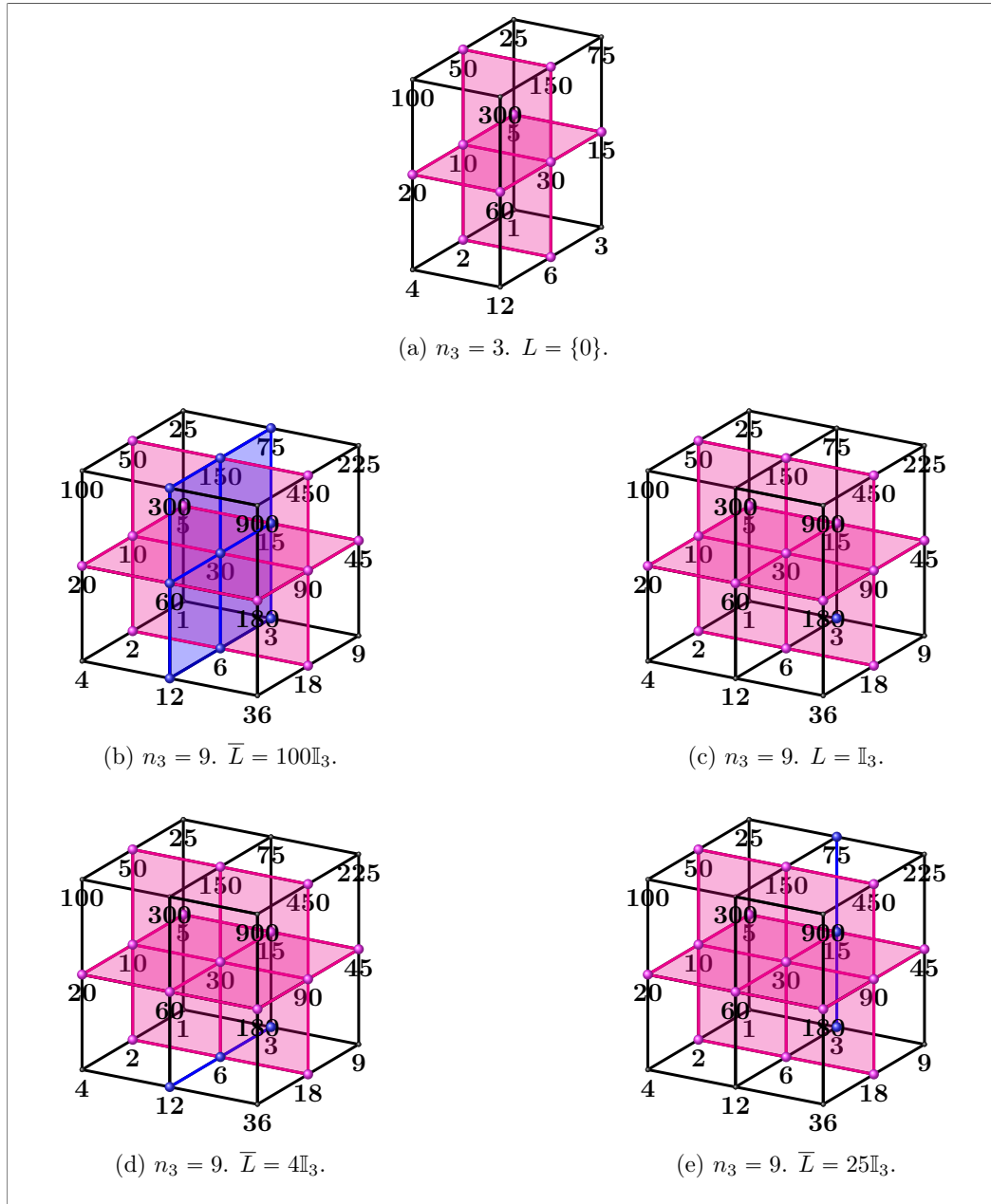

Lattice representations of tiling complements of the 12600 extended Vuza rhythms for $p_1 = 2$, $n_1 = 2$, $p_2 = 5$, and $n_2 = 5$.

Figure 4.8: $n = 900$. $A_1 \oplus A_2 = 100\mathbb{I}_3 \oplus 36\mathbb{I}_5$.

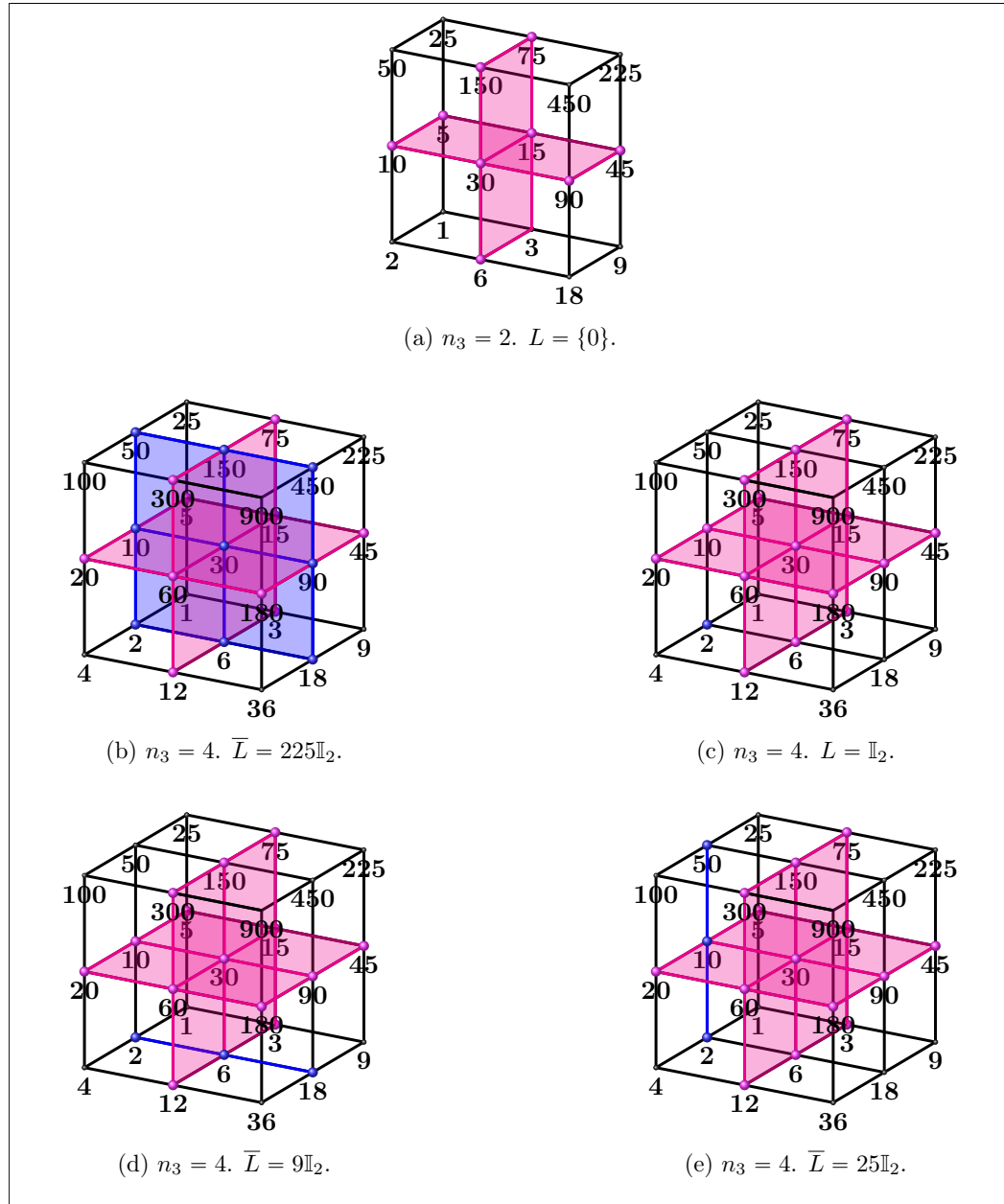

Lattice representations of tiling complements of the 1920 extended Vuza rhythms for $p_1 = 3$, $n_1 = 3$, $p_2 = 5$, and $n_2 = 5$.

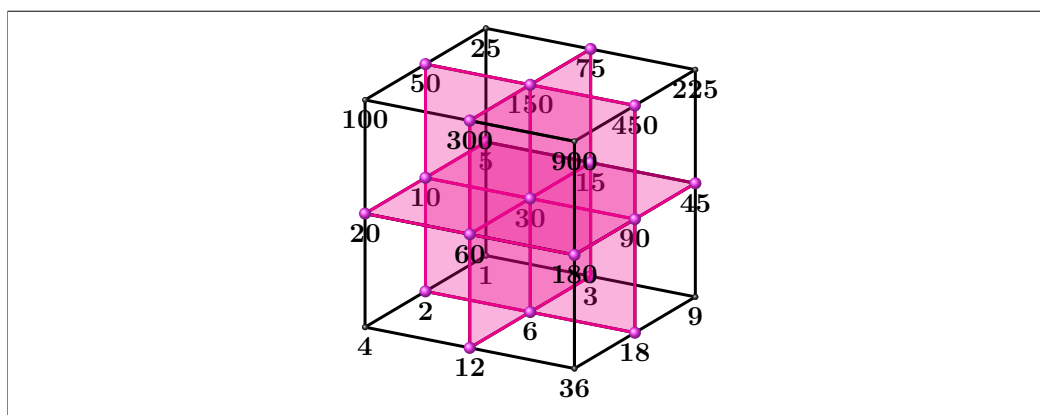
Figure 4.9: $n = 900$. $A_{CM} = 225\mathbb{I}_2 \oplus 100\mathbb{I}_3 \oplus 36\mathbb{I}_5$.

Lattice representations of the tiling complements of the 7608 aperiodic rhythms with $R_B = \{4, 9, 25, 36, 100, 225, 900\}$.

Table 4.5: Number of extended Vuza canons for $n = 900$, with $n_3 \in \{2, 3, 5, 6, 10, 15\}$.

p_1	n_1	p_2	n_2	n_3	L	$\#K$	S_A	$\#B$
2	25	3	3	2	{0}	1	{3, 5, 25}	15600
25	2	3	3	2	{0}	1	{3, 4}	67783088736
5	10	3	3	2	{0}	1	{3, 4, 5}	15840
10	5	3	3	2	{0}	1	{3, 5}	235200
2	9	5	5	2	{0}	1	{3, 5, 9}	118080
9	2	5	5	2	{0}	1	{4, 5}	1302000
3	6	5	5	2	{0}	1	{3, 4, 5}	62160
6	3	5	5	2	{0}	1	{3, 5}	123840
3	25	2	2	3	{0}	1	{2, 5, 25}	870000
25	3	2	2	3	{0}	1	{2, 9}	405323290006272
5	15	2	2	3	{0}	1	{2, 5, 9}	585900
15	5	2	2	3	{0}	1	{2, 5}	3572152200
2	6	5	5	3	{0}	1	{2, 5, 9}	606526200
6	2	5	5	3	{0}	1	{2, 5}	481892400
3	4	5	5	3	{0}	1	{2, 4, 5}	45859200
4	3	5	5	3	{0}	1	{5, 9}	21816000
3	15	2	2	5	{0}	1	{2, 3, 25}	30487590000
15	3	2	2	5	{0}	1	{2, 3}	6199976956848428880
5	9	2	2	5	{0}	1	{2, 3, 9}	14392209600
9	5	2	2	5	{0}	1	{2, 25}	9397268160000
2	10	3	3	5	{0}	1	{2, 3, 25}	28101810330000
10	2	3	3	5	{0}	1	{2, 3}	19135986535691625600
5	4	3	3	5	{0}	1	{2, 3, 4}	1290026373120
4	5	3	3	5	{0}	1	{3, 25}	221859000000
2	3	5	5	6	{0}	1	{5, 9}	1198799538300000
2	3	5	5	6	{0, 1}	2	{2, 5, 9}	619200
2	3	5	5	6	{0, 1, 2}	3	{3, 5, 9}	480
2	3	5	5	6	{0, 3}	8	{2, 5, 9}	2476800
2	3	5	5	6	{0, 2, 4}	9	{3, 5, 9}	1440
3	2	5	5	6	{0}	1	{4, 5}	4261202400000
3	2	5	5	6	{0, 1}	2	{2, 4, 5}	98400
3	2	5	5	6	{0, 1, 2}	3	{3, 4, 5}	240
3	2	5	5	6	{0, 3}	8	{2, 4, 5}	393600
3	2	5	5	6	{0, 2, 4}	9	{3, 4, 5}	720
2	5	3	3	10	{0}	1	{3, 25}	70815038895648196875000
2	5	3	3	10	{0, 1}	2	{2, 3, 25}	7733880000
2	5	3	3	10	{0, 1, 2, 3, 4}	5	{3, 5, 25}	120
2	5	3	3	10	{0, 5}	32	{2, 3, 25}	123742080000
2	5	3	3	10	{0, 2, 4, 6, 8}	25	{3, 5, 25}	600
5	2	3	3	10	{0}	1	{3, 4}	358259231912762271522816
5	2	3	3	10	{0, 1}	2	{2, 3, 4}	12015371520
5	2	3	3	10	{0, 1, 2, 3, 4}	5	{3, 4, 5}	96
5	2	3	3	10	{0, 5}	32	{2, 3, 4}	192245944320
5	2	3	3	10	{0, 2, 4, 6, 8}	25	{3, 4, 5}	480
3	5	2	2	15	{0}	1	{2, 25}	3905864529876000000000000
3	5	2	2	15	{0, 1, 2}	3	{2, 3, 25}	9540000
3	5	2	2	15	{0, 1, 2, 3, 4}	5	{2, 5, 25}	1800
3	5	2	2	15	{0, 5, 10}	243	{2, 3, 25}	772740000
3	5	2	2	15	{0, 3, 6, 9, 12}	125	{2, 5, 25}	45000
5	3	2	2	15	{0}	1	{2, 9}	2922314149256236917556396032
5	3	2	2	15	{0, 1, 2}	3	{2, 3, 9}	21792240
5	3	2	2	15	{0, 1, 2, 3, 4}	5	{2, 5, 9}	2052
5	3	2	2	15	{0, 5, 10}	243	{2, 3, 9}	1765171440
5	3	2	2	15	{0, 3, 6, 9, 12}	125	{2, 5, 9}	51300

Table 4.6: Number of extended Vuza canons for $n = 900$, with $n_3 \in \{4, 9, 25\}$.

p_1	n_1	p_2	n_2	n_3	L	$\#K$	S_A	$\#B$
5	5	3	3	4	{0}	1	{3, 5}	4393656000
5	5	3	3	4	{0, 1}	2	{2, 3, 5}	1920
5	5	3	3	4	{0, 2}	4	{3, 4, 5}	3840
5	5	2	2	9	{0}	1	{2, 5}	492531744599996000
5	5	2	2	9	{0, 1, 2}	3	{2, 3, 5}	12600
5	5	2	2	9	{0, 3, 6}	27	{2, 5, 9}	113400
2	2	3	3	25	{0}	1	{2, 3}	4490273576208113571719324814532411392
2	2	3	3	25	{0, 1, 2, 3, 4}	5	{2, 3, 5}	281232
2	2	3	3	25	{0, 5, 10, 15, 20}	3125	{2, 3, 25}	175770000

4.6 Testing necessity of condition (T2)

As mentioned in Section 4.3, we wanted to test the *CS Algorithm* and the *SAT Encoding Algorithm* not only to find all the complements of a given aperiodic rhythm for a certain period n of the canon. A second objective was to try to test some "critical" rhythms which could be candidates for a non-T2 aperiodic canon.

We have therefore created a short routine in *Wolfram Mathematica* capable of producing a 0-1 product $A(x)$ of cyclotomic polynomials which had among its factors at least one whose index's prime power factors were not in R , by testing the divisibility by the Coven-Meyerowitz complement characteristic polynomial. Such $A(x)$ is by construction overloaded with superfluous cyclotomic factors; hence it may be hoped that some complements $B(x)$ will lack at least one product of elements of S_B in their R_B , i.e. (T2) might be false though $A \oplus B = \mathbb{Z}_n$. Therefore, we were interested in determining whether a given rhythm A admits an aperiodic tiling complement B . For this reason, being able to verify the tiling property of a rhythm A in a reasonable amount of time is important.

In Table 4.7, we report the rhythms tested with our method. The runtimes required to determine the non-existence of an aperiodic complement vary in a range from 1 minute (for the rhythms in \mathbb{Z}_{1050} , \mathbb{Z}_{2310} , and \mathbb{Z}_{6300}) up to 10 minutes (for the rhythm in \mathbb{Z}_{27225}).

Table 4.7: Rhythms with superfluous cyclotomic factors checked.

n	Rhythm tested
1050	{0, 15, 30, 35, 45, 60, 70, 75, 90, 105}
2310	{0, 5, 6, 10, 12, 18, 24, 26, 30, 31, 36}
6300	{0, 2, 4, 5, 6, 7, 8, 10, 12, 350, 352, 354, 355, 356, 357, 358, 360, 362}
27225	{0, 9, 15, 18, 24, 27, 30, 36, 39, 45, 54, 3025, 3034, 3040, 3043, 3049, 3052, 3055, 3061, 3064, 3070, 3079, 6050, 6059, 6065, 6068, 6074, 6077, 6080, 6086, 6089, 6095, 6104}

Figure 4.10: $n = 1050$. $R_A = \{2, 10, 21, 25, 50, 105\}$.

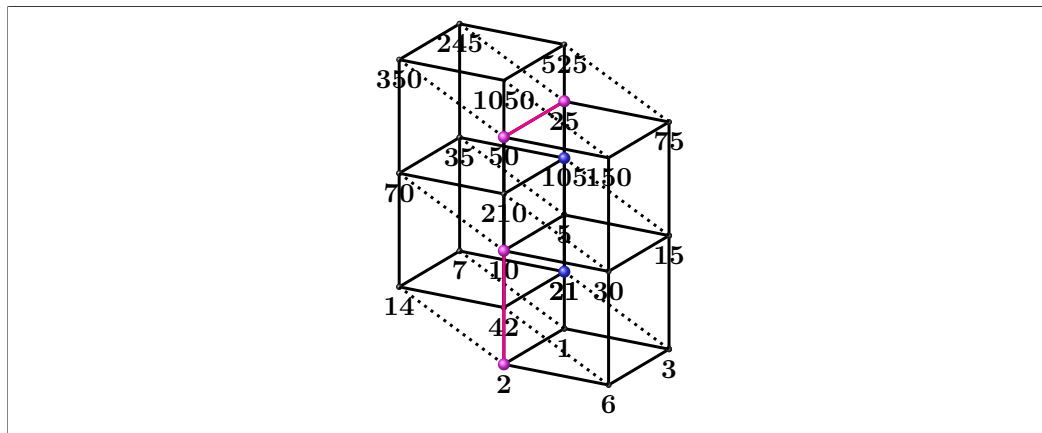

Lattice representation of the non-tiling rhythm $A = \{0, 15, 30, 35, 45, 60, 70, 75, 90, 105\}$. No prime power dividing 21 or 105 (in blue) is in S_A .

Figure 4.11: $n = 6300$. $R_A = \{3, 4, 9, 10, 20, 28, 100, 140, 700\}$.

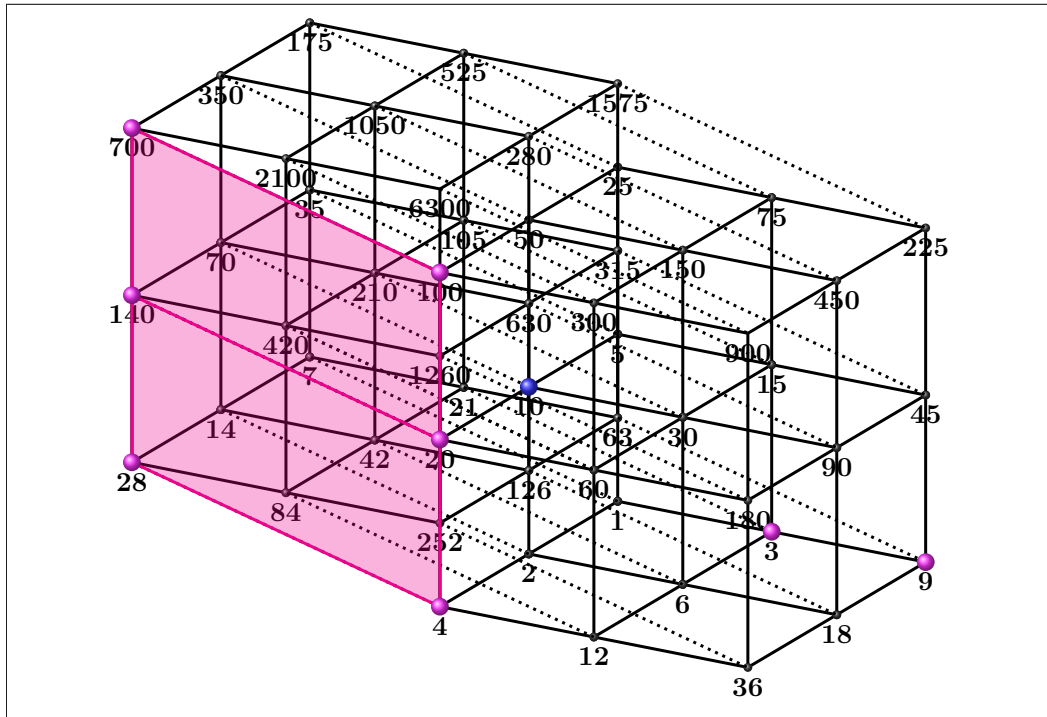

Lattice representation of the non-tiling rhythm $A = \{0, 2, 4, 5, 6, 7, 8, 10, 12, 350, 352, 354, 355, 356, 357, 358, 360, 362\}$. No prime power dividing 10 (in blue) is in S_A .

Bibliography

- [1] E. Amiot. Why rhythmic Canons are interesting. *E. Lluís-Puebla, G. Mazzola et T. Noll (eds.), Perspectives of Mathematical and Computer-Aided Music Theory, EpOs*, pages 190–209, 2004.
- [2] E. Amiot. New perspectives on rhythmic canons and the spectral conjecture. *Journal of Mathematics and Music*, 3(2):71–84, 2009.
- [3] E. Amiot. Structures, algorithms, and algebraic tools for rhythmic canons. *Perspectives of new music*, 49(2):93–142, 2011.
- [4] M. Andreatta, C. Agon, and E. Amiot. Tiling problems in music composition: Theory and implementation. *International Computer Music Conference*, pages 156–163, 2002.
- [5] G. Auricchio, L. Ferrarini, S. Gualandi, G. Lanzarotto, and L. Pernazza. A sat encoding to compute aperiodic tiling rhythmic canons. In *International Conference on Integration of Constraint Programming, Artificial Intelligence, and Operations Research*, pages 14–23. Springer, 2022.
- [6] G. Auricchio, L. Ferrarini, and G. Lanzarotto. An integer linear programming model for tilings. *arXiv preprint arXiv: 2107.04108*, 2021.
- [7] O. Bailleux and Y. Boufkhad. Efficient cnf encoding of boolean cardinality constraints. In *International conference on principles and practice of constraint programming*, pages 108–122. Springer, 2003.
- [8] N.G. De Bruijn. On the factorization of cyclic groups. *Proceedings of the Koninklijke Nederlandse Akademie van Wetenschappen: Series A: Mathematical Sciences*, 61(4):370–377, 1953.
- [9] E.M. Coven and A. Meyerowitz. Tiling the integers with translates of one finite set. *Journal of Algebra*, 212(1):161–174, 1999.
- [10] N.G. de Bruijn. On the factorization of finite abelian groups. *Proceedings of the Koninklijke Nederlandse Akademie van Wetenschappen: Series A: Mathematical Sciences*, 61(3):258–264, 1953.

- [11] G. Fidanza. *Canoni ritmici a mosaico. Tesi di Laurea, Università degli Studi di Pisa*, 2007.
- [12] H. Friepertinger, L. Reich, et al. *Remarks on rhythmical canons*. Citeseer, 2005.
- [13] LLC Gurobi Optimization. *Gurobi optimizer reference manual*, 2021.
- [14] G. Hajós. Über einfache und mehrfache bedeckung des n -dimensionalen raumes mit einem würfelgitter. *Mathematische Zeitschrift*, 47(1):427–467, 1942.
- [15] G. Hajós. Sur la factorisation des groupes abéliens. *Časopis Pěst. Mat. Fys.*, 74:157–162, 1950.
- [16] G. Hajós. Sur le probleme de factorisation des groupes cycliques. *Acta Mathematica Academiae Scientiarum Hungarica*, 1(2):189–195, 1950.
- [17] A. Ignatiev, A. Morgado, and J. Marques-Silva. PySAT: A Python toolkit for prototyping with SAT oracles. In *SAT*, pages 428–437, 2018.
- [18] F. Jedrzejewski. *Mathematical theory of music*. Ircam-Centre Pompidou, Parigi, 2006.
- [19] F. Jedrzejewski. Enumeration of Vuza Canons. *arXiv preprint arXiv: 1304.6609*, 2013.
- [20] M.N. Kolountzakis and M. Matolcsi. Complex Hadamard matrices and the spectral set conjecture. *Collectanea Mathematica*, Extra:281–291, 2006.
- [21] M.N. Kolountzakis and M. Matolcsi. Algorithms for translational tiling. *Journal of Mathematics and Music*, 3(2):85–97, 2009.
- [22] G. Lanzarotto and L. Pernazza. Extended vuza canons. In *International Conference on Mathematics and Computation in Music*, pages 112–126. Springer, 2022.
- [23] J.H. Liang. *Machine Learning for SAT Solvers*. PhD thesis, University of Waterloo, December 2018.
- [24] T. Philipp and P. Steinke. Pblib—a library for encoding pseudo-boolean constraints into cnf. In *International Conference on Theory and Applications of Satisfiability Testing*, pages 9–16. Springer, 2015.
- [25] L. Rédei. Zwei lückensätze über polynome in endlichen primkörpern mit anwendung auf die endlichen abelschen gruppen und die gaussischen summen. *Acta Mathematica*, 79:273–290, 1947.
- [26] L. Rédei. Ein Beitrag zum Problem der Faktorisaton von endlichen abelschen Gruppen. *Acta Mathematica Academiae Scientiarum Hungarica*, 1(2-4):197–207, 1950.

- [27] A.D. Sands. On the factorisation of finite abelian groups. ii. *Acta Mathematica Hungarica*, 13(1-2):153–169, 1962.
- [28] A.D. Sands. On the factorisation of finite abelian groups. iii. *Acta Mathematica Academiae Scientiarum Hungarica*, 25(3-4):279–284, 1974.
- [29] D.T. Vuza. Supplementary sets and regular complementary unending canons (part one). *Perspectives of New Music*, pages 22–49, 1991.
- [30] D.T. Vuza. Supplementary sets and regular complementary unending canons (part three). *Perspectives of New Music*, pages 102–124, 1992.
- [31] D.T. Vuza. Supplementary sets and regular complementary unending canons (part two). *Perspectives of New Music*, pages 184–207, 1992.
- [32] D.T. Vuza. Supplementary sets and regular complementary unending canons (part four). *Perspectives of New Music*, pages 270–305, 1993.

Résumé

On étudie les canons rythmiques de pavage, qui sont des compositions contrapuntiques purement rythmiques. Issu du problème analogue de la factorisation des groupes abéliens finis, que des canons rythmiques de pavage a périodique ont été étudiés : ce sont des canons qui pavage un certain intervalle de temps dans lequel chaque voix (rythme interne) joue à une séquence a périodique de battements, et la séquence des battements de départ de chaque voix (rythme externe) est également a périodique.

La thèse propose un ensemble de théorèmes montrant des méthodes de construction de canons rythmiques a périodiques et présente également des avancées dans le domaine du calcul en fournissant deux nouveaux algorithmes résultant plus efficaces que ceux connus dans la littérature d'au moins un ordre de grandeur.

Canons de Vuza, Problèmes de pavage

Résumé en anglais

We deal with tiling rhythmic canons, that are purely rhythmic contrapuntal compositions. Stemming from the analogous problem of factorizing finite Abelian groups, aperiodic tiling rhythmic canons have been studied : these are canons that tile a certain interval of time in which each voice (inner voice) plays at an aperiodic sequence of beats, and the sequence of starting beats of every voice (outer voice) is also aperiodic.

The thesis proposes a set of theorems showing methods for constructing aperiodic rhythmic canons, and it also presents advances in the field of computation by providing two new resulting algorithms that are more efficient than those known in the literature by at least an order of magnitude.

Vuza canons, Tiling problems