



HAL
open science

Heegaard Floer homology and contact structures

Paolo Ghiggini

► **To cite this version:**

Paolo Ghiggini. Heegaard Floer homology and contact structures. Mathematics [math]. Université de Nantes, 2019. tel-03065760

HAL Id: tel-03065760

<https://hal.science/tel-03065760>

Submitted on 18 Dec 2020

HAL is a multi-disciplinary open access archive for the deposit and dissemination of scientific research documents, whether they are published or not. The documents may come from teaching and research institutions in France or abroad, or from public or private research centers.

L'archive ouverte pluridisciplinaire **HAL**, est destinée au dépôt et à la diffusion de documents scientifiques de niveau recherche, publiés ou non, émanant des établissements d'enseignement et de recherche français ou étrangers, des laboratoires publics ou privés.

Universit de Nantes, Laboratoire de Mathmatiques Jean Leray

Heegaard Floer homology and contact structures

Mémoire présenté par

Paolo Ghiggini

en vue d'obtenir l'habilitation à diriger des recherches.

Rapporteurs :

- **Emmanuel Giroux**, Directeur de recherches, École Normale Supérieure
- **Cameron Gordon**, Professeur, University of Texas at Austin
- **Peter Ozsváth**, Professeur, Princeton University

Jury :

- **Michel Boileau**, Professeur, Aix-Marseille Université
- **Vincent Colin**, Professeur, Université de Nantes
- **Emmanuel Giroux**, Directeur de recherches, École Normale Supérieure
- **Christine Lescop**, Directrice de recherches, Université Grenoble Alpes
- **Jacob Rasmussen**, Professeur, University of Cambridge

Date de soutenance : 9 dcembre 2019

Contents

1 Preliminaries	8
1.1 Contact structures	8
1.2 Symplectic fillability	10
1.3 Heegaard Floer homology	12
1.4 Sutured manifolds and Floer homology	15
2 Giroux torsion, fillability and the contact invariant	18
2.1 Introduction	18
2.2 A word about integer coefficients	24
2.3 Generalised Lutz twists and contact invariants	25
2.4 Contact structures on the Brieskorn spheres $-\Sigma(2, 3, 6n - 1)$. .	26
2.4.1 Construction of the tight contact structures	26
2.4.2 Computation of the contact invariants	28
2.4.3 Contact structures without Liouville fillings	30
3 Detecting fibred knots	32
3.1 Introduction	32
3.2 Sutured Hierarchies	34
3.3 From nonfibredness to taut foliations	37
3.4 From taut foliations to knot Floer homology	41

4	Heegaard Floer homology and embedded contact homology	44
4.1	Introduction	44
4.2	Moduli spaces of J -holomorphic curves	48
4.3	Heegaard Floer homology	52
4.3.1	A review of Heegaard Floer homology	52
4.3.2	A geometric interpretation of the U -map	54
4.3.3	Adapting \widehat{HF} to an open book decomposition	58
4.4	Embedded contact homology	60
4.4.1	A review of embedded contact homology	60
4.4.2	Morse-Bott theory for embedded contact homology	62
4.4.3	Embedded contact homology of manifolds with torus boundary	64
4.4.4	How to prove Theorem 4.4.11	67
4.4.5	Sutured embedded contact homology	73
4.4.6	Periodic Floer homology and open books	77
4.5	The open-closed maps Φ and Φ^+	79
4.5.1	The maps Φ and $\widehat{\Phi}_*$	80
4.5.2	The map Φ^+	81
4.6	The closed-open map Ψ	85
4.6.1	Definition of Ψ	86
4.6.2	Ψ is a chain map	88
4.7	Homotopies	95
4.7.1	Homotopy for $\Psi \circ \Phi$	96
4.7.2	Homotopy for $\Phi \circ \Psi$	101
4.8	Stabilisation	104

Preface

This text is an exposition of the work on the interaction between contact topology in dimension three and Heegaard Floer homology which I did in the years approximately between 2004 and 2012. It is divided into four chapters: the first one is a quick exposition of background material about contact structures, Heegaard Floer homology and sutured manifolds, while the following three, which contain the original material, correspond each to a different point of view on the topic.

The second chapter deals with applications of Heegaard Floer homology to contact topology centred on the relation between the Ozsváth–Szabó contact invariants, Giroux torsion and symplectic fillability. The main results of this chapter are the first examples of tight contact structures with trivial Ozsváth–Szabó contact invariants, the effect of generalised Lutz twists on those invariants, the classification of tight contact structures on the three manifolds $-\Sigma(2, 3, 6n - 1)$ for $n \geq 2$ and the first examples of strongly fillable contact structures which are not Weinstein fillable. As it is common in Mathematics when a story is told for the second time, this chapter follows a logical rather than chronological order: the results on the effect of generalised Lutz twists on the contact invariant with twisted coefficients and the classification of tight contact structures on $-\Sigma(2, 3, 6n - 1)$ are stated first, even if they came the last, and previous results are derived as corollaries, even if they were originally proved by more *ad hoc* arguments.

The third chapter deals with an application of contact topology to Heegaard Floer homology: I will describe how contact structures, via the contact invariant, played a fundamental role in the original proof that knot Floer homology detects fibred knots, focusing on the genus one case. As a corollary it follows that, if the Poincaré homology sphere is obtained by surgery on K , then K is a trefoil knot, answering a question of Kirby and Zhang. The fourth chapter is, up to minor modifications, a survey on the isomorphism between Heegaard Floer homology and embedded contact homology which has been submitted to the proceedings of the Boyerfest.

After 2012 I started working more on higher dimensional contact and symplectic topology. These more recent results are not included in this text to preserve

at least some unity of action, given that unity of time and place are irremediably lost, but I would still like to mention them briefly. In [16], with Vincent Colin, Ko Honda and Michael Hutchings we extended the definition of sutured manifold to high dimension, defined the notion of a contact form adapted to a sutured manifold, defined sutured contact homology and studied some of its basic properties. The three-dimensional part of that work is briefly mentioned in Subsection 4.4.5. In [42], with Klaus Niederkrüger and Chris Wendl, we studied the topology of subcritical handle attachments and produced the first examples of tight contact structures on connected sums in dimension at least five which are not the result of a contact connected sum. In contrast, basic convex surface theory implies that, in dimension three, a tight contact structure on a connected sum necessarily arises as a contact connected sum. In the series of articles [6, 8, 7] with Baptiste Chantraine, Georgios Dimitroglou Rizell and Roman Golovko we developed a Floer homology for Lagrangian cobordisms and used it to give topological constraints on Lagrangian cobordisms from a Legendrian submanifold to itself, to study the effect of Lagrangian surgeries on Floer homology and, using the latter, to prove that the wrapped Fukaya category of a Weinstein manifold is generated by the cocores of the critical handles of a Weinstein handle decomposition.

Acknowledgements

First of all, I would like to thank the referees for reading this text and the members of the defense committee for participating to my defense. Many of the results described here have been obtained in collaboration, and I wish to thank all my collaborators, including those who contributed to works which will not be discussed in this text. In alphabetical order they are: Gianluca Bande, Baptiste Chantraine, Vincent Colin, Georgios Dimitroglou Rizell, Marco Golla, Roman Golovko, Ko Honda, Michael Hutchings, Dieter Kotschick, Paolo Lisca, Klaus Niederkrüger, Olga Plamenevskaya, Stephan Schönenberger, András Stipsicz, Jeremy Van Horn-Morris and Chris Wendl. Without them, much less would have been possible. Special thanks go in particular to those who helped my first steps in mathematics and from which I learnt most of what I know about contact topology: my advisor Paolo Lisca, András Stipsicz and especially Ko Honda: there is no result in this text to which he didn't contribute either as a coauthor or with some clever suggestion. I would also like to thank Emmanuel Giroux for a very helpful piece of advice in the early stage of my career, Yasha Eliashberg, from which I learnt about the conjectural relation between Giroux torsion and symplectic fillability which was an important source of inspiration, Peter Ozsváth for some patient explanations of Heegaard Floer homology and his constant encouragement, Steve Boyer, Joseph Maher and Stephan Tillman for helpful discussions about three-manifold topology and sutured manifolds, and Stefan Friedl for sharing his excitement about fibred knots and for pointing out a mistake in the first version of [39]. Many more should be thanked for useful conversations, but it would be impossible to list them all. Finally, I would like

to thank the geometry and topology groups of UQAM, Udm and the University of Nantes for providing very pleasant and exciting working environments.

List of publications discussed in the text

1. “Tight contact structures on the Brieskorn spheres $-\Sigma(2, 3, 6n - 1)$ and contact invariants” (with J. Van Horn-Morris), *J. Reine Angew. Math.* 718 (2016), 1–24;
2. “The equivalence of Heegaard Floer homology and embedded contact homology III: from hat to plus”, (with V. Colin and K. Honda), preprint, arXiv:1208.1526;
3. “The equivalence of Heegaard Floer homology and embedded contact homology via open book decompositions II”, (with V. Colin and K. Honda), preprint, arXiv:1208.1077;
4. “The equivalence of Heegaard Floer homology and embedded contact homology via open book decompositions I”, (with V. Colin and K. Honda), preprint, arXiv:1208.1074;
5. “Equivalence of Heegaard Floer homology and embedded contact homology via open book decompositions” (with V. Colin and K. Honda), *Proc. Natl. Acad. Sci. USA* 108 (2011), no. 20, 8100–8105;
6. “Sutures and contact homology I” (with V. Colin, K. Honda e M. Hutchings), *Geom. Topol.* 15 (2011), no. 3, 1749–1842;
7. “Embedded contact homology and open book decompositions” (with V. Colin and K. Honda), preprint, arXiv:1008.2734;
8. “Knot Floer homology detects genus-one fibred knots”, *Amer. J. Math.* 130 (2008), no. 5, 1151–1169;
9. “Giroux torsion and twisted coefficients” (with K. Honda), preprint, arXiv:0804.1568;
10. “The vanishing of the contact invariant in the presence of torsion” (with K. Honda and J. Van Horn-Morris), preprint, arXiv:0706.1602;
11. “Infinitely many universally tight contact manifolds with trivial Ozsváth–Szabó contact invariants”, *Geom. Topol.* 10 (2006), 335–357;
12. “Ozsváth–Szabó invariants and fillability of contact structures”, *Math. Z.* 253 (2006), no. 1, 159–175;
13. “Strongly fillable contact 3–manifolds without Stein fillings” *Geom. Topol.* 9 (2005), 1677–1687;

14. “On the classification of tight contact structure” (with S. Schönenberger), in “Topology and Geometry of manifolds” Proceedings of Symposia in Pure Mathematics, volume 71 (2003), editors Gordana Matić and Clint McCrory.

List of publications not discussed in the text

1. “Geometric generation of the wrapped Fukaya category of Weinstein manifolds and sectors” (with B. Chantraine, G. Dimitroglou Rizell and R. Golovko), preprint, arXiv:1712.09126;
2. “Surface singularities and planar contact structures” (with M. Golla and O. Plamenevskaya), Ann. Inst. Fourier (to appear);
3. “Holomorphic spheres and four-dimensional symplectic pairs” (with G. Bande), J. Geom. Anal. (to appear);
4. “Floer theory for Lagrangian cobordisms” (with B. Chantraine, G. Dimitroglou Rizell and R. Golovko), J. Differential Geom. (to appear);
5. “Subcritical contact surgeries and the topology of symplectic fillings” (with K. Niederkrüger and C. Wendl), J. Éc. polytech. Math. 3 (2016), 163–208;
6. “Open book decompositions versus prime factorizations of closed, oriented 3-manifolds” (with P. Lisca), in “Interactions between low-dimensional topology and mapping class groups”, 145–155, Geom. Topol. Monogr. 19, Geom. Topol. Publ., Coventry, 2015;
7. “Noncommutative augmentation categories” (with B. Chantraine, G. Dimitroglou Rizell and R. Golovko), in “Proceedings of the XXII Gökova Geometry/Topology Conference” (2015);
8. “Floer homology and Lagrangian concordance” (with B. Chantraine, G. Dimitroglou Rizell e R. Golovko), in “Proceedings of the XXI Gökova Geometry/Topology conference”, (2014);
9. “On tight contact structures with negative maximal twisting number on small Seifert manifolds”, Algebr. Geom. Topol. 8 (2008), no. 1, 381–396;
10. “Tight contact structures on some small Seifert fibred 3-manifolds” (with P. Lisca and A. Stipsicz), Amer. J. Math. 129 (2007) no. 5, 1403–1447;
11. “Linear Legendrian curves in T^3 ”, Math. Proc. Cambridge Philos. Soc. 140 (2006), no. 3, 451–473;
12. “Classification of tight contact structures on small Seifert 3-manifolds with $e_0 \geq 0$ ” (with P. Lisca and A. Stipsicz), Proc. Amer. Math. Soc. 134 (2006), no. 3, 909–916;

13. “Tight contact structures on Seifert manifolds over T^2 with one singular fibre”, *Algebr. Geom. Topol.* 5 (2005), 785–833;
14. “Stability theorems for symplectic and contact pairs” (with G. Bande and D. Kotschick), *Int. Math. Res. Not.* (2004), 3673–3688.

Chapter 1

Preliminaries

1.1 Contact structures

A *contact structure* ξ on a $(2n + 1)$ -dimensional manifold M is a maximally nonintegrable plane field, and the pair (M, ξ) is called a *contact manifold*. In this text all contact structures are *cooriented*, which means that $\xi = \ker \alpha$ for some 1-form α on M , called a *contact form*. We will distinguish a contact structure ξ by its *conjugate* $\bar{\xi}$, which is the same hyperplane field as ξ but with the opposite coorientation. If α is a contact form for ξ , then $-\alpha$ is a contact form for $\bar{\xi}$; thus α is well defined up to multiplication by a strictly positive function on M . Frobenius theorem states that ξ is a contact structure if and only if $\alpha \wedge (d\alpha)^n$ is a volume form, so M is an orientable manifold. The sign of $\alpha \wedge (d\alpha)^n$ does not depend on the choice of the contact form (inducing the given coorientation), and therefore ξ orients M . If (M, ξ) is a contact manifold, we will always regard M as an oriented manifold with the orientation induced by ξ .

Two contact manifolds (M_0, ξ_0) and (M_1, ξ_1) are *isomorphic* (or *contactomorphic*) if there exists a diffeomorphism $\varphi: M_0 \rightarrow M_1$ such that $\varphi_*\xi_0 = \xi_1$. Two contact structures ξ_0 and ξ_1 on the same manifold M are *isotopic* if there is a diffeomorphism $\varphi: M \rightarrow M$ smoothly isotopic to the identity such that $\varphi_*\xi_0 = \xi_1$. Finally, ξ_0 and ξ_1 are *homotopic* if they can be connected via a smooth family of hyperplane fields ξ_t . We could be tempted to introduce one further equivalence relation by requiring homotopy through contact structures. However a classical theorem of Gray implies that, at least on closed manifolds, homotopy through contact structures implies isotopy.

By the recent result of Borman, Eliashberg and Murphy [2] contact structures exist on any odd-dimensional manifold as long as a certain homotopic obstruction vanishes. However in this text we will consider only contact structures on

three-manifolds, where the existence is a classical result due to Martinet and Lutz [86, 85].

Definition 1.1.1. Let (M, ξ) be a contact three-manifold. We say that ξ is *overtwisted* if there is an embedded disc $D \subset M$ such that $\xi|_{\partial D} = TD|_{\partial D}$. On the other hand, if no such disc exists, ξ is called *tight*.

The existence theorem for contact structures on three-manifolds can be easily improved to prove that every homotopy class of 2-plane fields on a three-manifold contains an overtwisted contact structure. Eliashberg introduced overtwisted contact structures in [19] to prove the following theorem.

Theorem 1.1.2 (Eliashberg [19]). *Two overtwisted contact structures on a closed three-manifold are isotopic if and only if they are homotopic as oriented plane fields.*

On the other hand, the problem of the existence and classification of tight contact structures on three manifolds is still largely open and almost nothing is known outside the realm of Seifert fibred manifolds. However it is not because of the subtleties of their classification that tight contact structures are interesting, but because of their relations with symplectic geometry and low-dimensional topology. We will explore some of these links in the next chapters. Recently a similar dichotomy between flexible overtwisted contact structures and rigid tight contact structures has emerged also in higher dimension by the work of Borman, Eliashberg and Murphy [2].

The topological notion of surgery can be adapted to the contact setting. A *Legendrian knot* (or link) L in (M, ξ) is a knot (or link) which is everywhere tangent to ξ . A Legendrian knot carries a canonical framing called the *contact framing*. A contact manifold (M', ξ') is obtained from (M, ξ) by *Legendrian surgery* (or *contact (-1) -surgery*) along L if M' is obtained from M by Dehn surgery along L with coefficient -1 with respect to the contact framing and ξ' is obtained by extending $\xi|_{M \setminus \nu(L)}$ so that the extension is tight inside the surgery solid torus. The classification of tight contact structures on solid tori [54, 48] shows that this extension is unique. *Contact $(+1)$ -surgery* is defined similarly and is the inverse operation of Legendrian surgery: if (M', ξ') is obtained from (M, ξ) by Legendrian surgery, then (M, ξ) is obtained from (M', ξ') by contact $(+1)$ -surgery. See [18] for more details on contact surgery.

Giroux torsion is a topological invariant of contact three-manifolds introduced by Giroux in [46, 47]. We denote by ζ_n , for $n \geq 1$, the contact structures $\zeta_n = \ker(\sin(2\pi n z)dx + \cos(2\pi n z)dy)$ on $T^2 \times [0, 1] = \mathbb{R}^2/\mathbb{Z}^2 \times [0, 1]$.

Definition 1.1.3. A contact three-manifold (M, ξ) has *Giroux torsion* n , for $n \geq 1$, if there is a contact embedding $(T^2 \times [0, 1], \zeta_n) \hookrightarrow (M, \xi)$ but no contact embedding of $(T^2 \times [0, 1], \zeta_{n+1})$. If no contact embedding of $(T^2 \times [0, 1], \zeta_n)$ exists for any n , then (M, ξ) has torsion 0. If there exists one for any n , then (M, ξ) has infinite torsion.

We can define Giroux torsion *along* a torus T by restricting Definition 1.1.3 to contact embeddings of $(T^2 \times [0, 1], \zeta_n)$ such that the image of $T^2 \times \{0\}$ is smoothly isotopic to T .

An overtwisted contact structure has infinite torsion by Eliashberg's classification. The converse is one of the most important open conjectures in three-dimensional contact topology:

Conjecture 1.1.4. *If (M, ξ) has infinite torsion, then it is overtwisted.*

The fundamental role of Giroux's torsion is exemplified by the coarse classification theorem of Colin, Giroux and Honda [17]: for every three-manifold there is a finite number of tight contact structures with the property that any other tight contact structure can be obtained from one of those by a finite number of modifications, called *generalised Lutz twists*, which increase Giroux's torsion. Lutz twists will play a crucial role also in this text, and therefore we will recall their definition.

Let (M, ξ) be a contact three-manifold. If $S \subset M$ is an embedded surface, the *characteristic foliation* of S is the singular foliation on S which integrates the singular line field $\xi \cap TS$. A torus $T \subset M$ is called *pre-Lagrangian* if its characteristic foliation is linear. By [35, Theorem 2.5.22] a Pre-Lagrangian torus T has a standard neighbourhood which is contactomorphic to $\mathbb{R}^2/\mathbb{Z}^2 \times [-\epsilon, \epsilon]$ with the contact structure $\ker(\sin(z)dx + \cos(z)dy)$.

Definition 1.1.5. A contact manifold (M, ξ') is obtained from (M, ξ) by a *generalised Lutz twist along T* if we replace a neighbourhood of T contactomorphic to $(T^2 \times [-\epsilon, \epsilon], \ker(\sin(z)dx + \cos(z)dy))$ with one which is contactomorphic to $(T^2 \times [-\epsilon, \epsilon], \ker(\sin(\vartheta(z))dx + \cos(\vartheta(z))dy))$, where $\vartheta: [-\epsilon, \epsilon] \rightarrow \mathbb{R}$ is a smooth function such that $\vartheta' > 0$, $\vartheta(-\epsilon) = -\epsilon$ and $\vartheta(\epsilon) = 2\pi + \epsilon$.

The homotopy class of the contact structure does not change after a generalised Lutz twist by [46, Theorem 2.2], but the isotopy class in general does. The result is often overtwisted, and this is always the case if the torus T is compressible: in fact, by Dehn's lemma, there is a curve on T which bounds an embedded disc in M whose interior is disjoint from T , and after a generalised Lutz twist, that curve is isotopic to a leaf of the characteristic foliation of a torus isotopic to T . Then that leaf bounds an overtwisted disc. On the other hand, when (M, ξ) is *universally tight* (which means that ξ pulls back to a tight contact structure on the universal cover of M) and T is incompressible, a generalised Lutz twist around T produces a tight contact structure; see [10].

1.2 Symplectic fillability

We recall that a *symplectic form* on a $2n$ -dimensional manifold W is a differential 2-form ω such that $d\omega = 0$ and ω^n is a volume form. There is a strong relationship between contact topology and symplectic topology due to the fact that

contact structures provide natural boundary conditions for symplectic structures on manifolds with boundary. The key observation is that, if (M, ξ) is a contact manifold and α is a contact form, then $d\alpha|_\xi$ is a symplectic form on ξ (in the sense of symplectic vector bundles) and moreover the conformal class of $d\alpha|_\xi$ is independent of the choice of the contact form. Depending on how tight the relation between contact structure and symplectic form is, there are several notions of symplectic fillability. Since ω orients W and ξ orients M , in all the definitions that follow we will require that the orientation of M as boundary of W coincides with the orientation induced by ξ .

Definition 1.2.1. A symplectic manifold (W, ω) is a *weak symplectic filling* of a contact three-manifold (M, ξ) if $\partial W = M$ and $\omega|_\xi > 0$.

By a slight abuse of notation, we denote the pull-back of ω to M by $\omega|_M$. This convention for the pull-back will be used throughout the text.

Definition 1.2.2. A symplectic manifold (W, ω) is a *strong symplectic filling* of a contact three-manifold (M, ξ) if $\partial W = M$ and there is a contact form α for ξ such that $\omega|_M = d\alpha$.

Definition 1.2.3. A symplectic manifold (W, ω) is a *Liouville filling* of a contact three-manifold (M, ξ) if $\partial W = M$ and $\omega = d\beta$ with $\beta|_M = \alpha$ for a contact form α of ξ .

Definition 1.2.4. A symplectic manifold (W, ω) is a *Weinstein filling* of a contact three-manifold (M, ξ) if it is a Liouville filling, and moreover the Liouville vector field Z , defined by the equation $\iota_Z \omega = \beta$, is gradient-like for a Morse function $f: W \rightarrow \mathbb{R}$ which has M as a regular level.

The complex analytic notion of *Stein filling* is equivalent, from a symplectic point of view, to the notion of Weinstein filling by [9]. Since Stein structures came under the spot before Weinstein structures, all statements in this work regarding Weinstein fillings were originally stated for Stein fillings. When the focus is not on the contact manifold at the boundary we will write Liouville or Weinstein *domain* instead of Liouville or Weinstein filling.

Example 1.2.5. The standard symplectic four-ball is a Weinstein domain; the contact structure induced on the boundary S^3 is called the *standard contact structure* and will be denoted by ξ_{st} .

Every notion of symplectic filling has a corresponding notion of cobordism, whose definition is straightforward. A symplectic cobordism has a *positive*, or *convex*, end at the boundary component where the boundary orientation coincides with the orientation coming from the contact structure, and has a *negative* or *concave* end where the two orientations disagree. We follow the convention that cobordisms go *from* the negative end *to* the positive end. To a filling of (M, ξ) of any type we can associate a cobordism of the same type

from (S^3, ξ_{st}) to (M, ξ) by removing a Darboux ball. In the following we will be interested only in Liouville and Weinstein cobordisms.

Every Weinstein cobordism from (M, ξ) to (M', ξ') , with $\xi = \ker \alpha$, is obtained from the trivial cobordism $([0, 1] \times M, d(e^t \alpha))$ by a sequence of index one and two symplectic handle attachments. On the boundary, the effect of an index one symplectic handle attachment is a contact self-connected sum and the effect of an index two symplectic handle attachment is a Legendrian surgery along a Legendrian knot. See [35, Chapter 6] or [50] for more on symplectic handle attachments.

The following inclusions

$$\left\{ \begin{array}{c} \text{Weinstein} \\ \text{Fillable} \end{array} \right\} \subset \left\{ \begin{array}{c} \text{Liouville} \\ \text{Fillable} \end{array} \right\} \subset \left\{ \begin{array}{c} \text{Strongly} \\ \text{Fillable} \end{array} \right\} \subset \left\{ \begin{array}{c} \text{Weakly} \\ \text{Fillable} \end{array} \right\} \subset \{\text{tight}\}$$

are all obvious but the last one, which is deep theorem of Eliashberg and Gromov [20, 51]. They are all strict: tightness does not imply weak fillability by Etnyre and Honda [25] and weak fillability does not imply strong fillability by Eliashberg [21]. In Subsection 2.4.3 I will describe the first (and, essentially, the only known) examples of strongly fillable but not Liouville fillable contact manifolds. Finally Bowden [5] proved that Liouville fillability does not imply Weinstein fillability by a modification of the examples in Subsection 2.4.3. However Bowden's examples are reducible, and it would be interesting to have Liouville fillable but not Weinstein fillable contact structures on irreducible manifolds.

1.3 Heegaard Floer homology

In this subsection we review some of the properties of Heegaard Floer homology. For the definitions and a more thorough exposition of the properties we refer to the original articles of Ozsváth and Szabó [93, 92, 97]. However, a sketch of the definition of \widehat{HF} will be given in Subsection 4.3.1.

Let M be a closed, connected, oriented three-manifold. We denote by \mathbb{F} the field with two elements and by $\mathbb{F}[H_2(M; \mathbb{Z})]$ the group algebra of $H_2(M; \mathbb{Z})$. Given an $\mathbb{F}[H_2(M; \mathbb{Z})]$ -algebra \mathbb{A} , the Heegaard Floer homology group $\widehat{HF}(M; \mathbb{A})$ is an \mathbb{A} -module which is an invariant of M up to diffeomorphism. If $\mathbb{A} = \mathbb{F}[H_2(M; \mathbb{Z})]$ we will write $\widehat{HF}(M)$ and if $\mathbb{A} = \mathbb{F}$ we will write $\widehat{HF}(M)$ for $\widehat{HF}(M; \mathbb{A})$. It is possible to define Heegaard Floer homology also in characteristic zero, with some extra complications, but characteristic two is sufficient for all applications we will describe.

Example 1.3.1. Given a \mathbb{Z} -module A , to any cohomology class $\omega \in H^2(M; A)$ we associate an $\mathbb{F}[H_2(M; \mathbb{Z})]$ -algebra \mathbb{A}_ω as follows. As a ring, $\mathbb{A}_\omega = \mathbb{F}[A]$, which we write as “polynomials” in a variable t with coefficients in \mathbb{F} and exponents in A , and the action of $c \in H_2(M; \mathbb{Z})$ is defined by

$$c \cdot t = t^{(\omega, c)}$$

via the Kronecker pairing between homology and cohomology, after regarding c as a homology class with coefficients in A via the natural map $H_2(M; \mathbb{Z}) \otimes A \rightarrow H_2(M; A)$. In practice we will always have $A = \mathbb{Z}$ or $A = \mathbb{R}$.

Let $\text{Spin}^c(M)$ denote the set of Spin^c structure on M . Following Turaev [111], we can identify $\text{Spin}^c(M)$ with the set of the equivalence classes of oriented 2-dimensional plane fields on M which are homotopic outside a ball. $\text{Spin}^c(M)$ is an affine space over $H^2(M; \mathbb{Z})$. If $\mathfrak{t} \in \text{Spin}^c(M)$, its *first Chern class* $c_1(\mathfrak{t}) \in H^2(M; \mathbb{Z})$ is, by definition, the Euler class of an oriented 2-plane field on M representing \mathfrak{t} . If $\alpha \in H^2(M; \mathbb{Z})$, then $c_1(\mathfrak{t} + \alpha) = c_1(\mathfrak{t}) + 2\alpha$. Heegaard Floer homology groups split according to Spin^c structures:

$$\widehat{HF}(M; \mathbb{A}) = \bigoplus_{\mathfrak{t} \in \text{Spin}^c(M)} \widehat{HF}(M, \mathfrak{t}; \mathbb{A}).$$

The groups $\widehat{HF}(M, \mathfrak{t}; \mathbb{A})$ are nontrivial only for finitely many Spin^c structures.

Heegaard Floer homology is functorial with respect to cobordisms. However, the general statement for twisted coefficients is quite involved; see [97, Section 3.1]. Here we will describe cobordism maps only in two cases: for coefficients in \mathbb{F} or in the algebras \mathbb{A}_ω of Example 1.3.1. Note that the former is the particular case of the latter for $A = \{0\}$. Let W be a connected oriented cobordism from M_0 to M_1 and $\Omega \in H^2(W; A)$ which restricts to $\omega_i \in H^2(M_i; A)$. For every Spin^c structure \mathfrak{s} on W there are maps (called *cobordism maps*)

$$\widehat{F}_{W, \mathfrak{s}}: \widehat{HF}(M_0, \mathfrak{s}|_{M_0}) \rightarrow \widehat{HF}(M_1, \mathfrak{s}|_{M_1}) \quad (1.1)$$

$$\widehat{F}_{W, \mathfrak{s}; \Omega}: \widehat{HF}(M_0, \mathfrak{s}|_{M_0}; \mathbb{A}_{\omega_0}) \rightarrow \widehat{HF}(M_1, \mathfrak{s}|_{M_1}; \mathbb{A}_{\omega_1}). \quad (1.2)$$

The “untwisted” map (1.1) is linear over \mathbb{F} and depends only on the diffeomorphism type of (W, \mathfrak{s}) relative to the boundary. The “twisted” map (1.2) is linear over \mathbb{A}_ω and depends, up to multiplication by powers of t , on the diffeomorphism type of (W, \mathfrak{s}) relative to the boundary and on Ω . Both are nonzero only for finitely many Spin^c structures. If (W, \mathfrak{s}) is a product Spin^c cobordism and $\Omega \in H^2(W; A) \cong H^2(M_i; A)$, then the maps $\widehat{F}_{W, \mathfrak{s}}$ and $\widehat{F}_{W, \mathfrak{s}; \Omega}$ are the identity.

Cobordism maps satisfy gluing formulas for concatenations of cobordisms.

Proposition 1.3.2 ([97, Theorems 3.4 and 3.9]). *if (W_1, \mathfrak{s}_1) and (W_2, \mathfrak{s}_2) are Spin^c cobordisms from M_0 to M_1 and from M_1 to M_2 , respectively, such that $\mathfrak{s}_1|_{M_1} = \mathfrak{s}_2|_{M_1}$, and W denotes the composed cobordism, then*

$$\widehat{F}_{W_2, \mathfrak{s}_2} \circ \widehat{F}_{W_1, \mathfrak{s}_1} = \sum_{\mathfrak{s} \in \text{Spin}^c(W): \mathfrak{s}|_{W_i} = \mathfrak{s}_i} \widehat{F}_{W, \mathfrak{s}}.$$

If moreover $\Omega \in H^2(W; A)$ and Ω_i is its restriction to W_i , then

$$\widehat{F}_{W_2, \mathfrak{s}_2; \Omega_2} \circ \widehat{F}_{W_1, \mathfrak{s}_1; \Omega_1} = \sum_{\mathfrak{s} \in \text{Spin}^c(W): \mathfrak{s}|_{W_i} = \mathfrak{s}_i} \widehat{F}_{W, \mathfrak{s}; \Omega} t^{(\Omega \cup (\mathfrak{s} - \mathfrak{s}_0), [W])}$$

for an arbitrary reference Spin^c structure \mathfrak{s}_0 .

Let (M, ξ) be a contact three-manifold. The contact structure determines a Spin^c structure \mathfrak{t}_ξ on M . The *Ozsváth–Szabó contact invariant*, or simply the contact invariant, of (M, ξ) with coefficients in an $\mathbb{F}[H_2(M; \mathbb{Z})]$ -algebra \mathbb{A} is an element $\underline{c}(\xi; \mathbb{A}) \in \widehat{HF}(-M, \mathfrak{t}_\xi; \mathbb{A})$ introduced by Ozsváth and Szabó in [96]. If $\mathbb{A} = \mathbb{F}$ we write $c(\xi)$ and if $\mathbb{A} = \mathbb{F}[H_2(M)]$ we write $\underline{c}(\xi)$ instead of $\underline{c}(\xi; \mathbb{A})$. The contact invariant is well defined up to multiplication by invertible elements of \mathbb{A} and its equivalence class is an invariant of ξ up to isotopy. Its definition and the proof of invariance rely on Giroux’s correspondence between contact structures and open book decompositions [49].

If $c_1(\mathfrak{t}_\xi)$ is a torsion class, then $\widehat{HF}(-M, \mathfrak{t}_\xi; \mathbb{A})$ is a \mathbb{Q} -graded vector space (see [89]) and, by [96, Proposition 4.6]¹, $\underline{c}(\xi; \mathbb{A}) \in \widehat{HF}_{-d(\xi)}(-M, \mathfrak{t}_\xi; \mathbb{A})$, where $d(\xi)$ is, up to factors, the homotopy invariant defined by Gompf in [50, Definition 4.2]. It is defined as follows: if (W, J) is an almost complex manifold with $\partial W = M$ and $\xi = TM \cap J(TM)$, then

$$d(\xi) = \frac{1}{4}(c_1(J)^2 - 2\chi(W) - 3\sigma(W) + 2) \quad (1.3)$$

where σ is the signature, χ the Euler characteristic, and $c_1(J)^2 \in \mathbb{Q}$ is well defined because $c_1(\xi)$ is a torsion class.

The main properties of the contact invariants are the following. More properties will be introduced when needed.

Theorem 1.3.3 (See [96, Theorem 1.4] and [90, Theorem 4.2]). *If ξ is overtwisted, then $\underline{c}(\xi; \mathbb{A}) = 0$ for every $\mathbb{F}[H_2(M; \mathbb{Z})]$ -algebra \mathbb{A} . If (W, Ω) is a weak symplectic filling of (M, ξ) and $\omega = [\Omega|_M] \in H^2(M; \mathbb{R})$, then $\underline{c}(\xi; \mathbb{A}_\omega)$ is a non-torsion element of $\widehat{HF}(-M, \mathfrak{t}_\xi; \mathbb{A}_\omega)$; in particular $\underline{c}(\xi; \mathbb{A}_\omega) \neq 0$.*

Corollary 1.3.4 (See also [38, Theorem 2.13]). *If ξ is strongly fillable, then $c(\xi) \neq 0$*

The contact invariant is functorial with respect to the change of coefficients.

Lemma 1.3.5. *If \mathbb{A}_0 and \mathbb{A}_1 are algebras over $\mathbb{F}[H_2(M; \mathbb{Z})]$ and $\mathbb{A}_0 \rightarrow \mathbb{A}_1$ is an algebra homomorphism, then there is a morphism of \mathbb{A}_0 -modules*

$$\widehat{HF}(M, \mathfrak{t}; \mathbb{A}_0) \rightarrow \widehat{HF}(M, \mathfrak{t}, \mathbb{A}_1).$$

If ξ is a contact structure in M , then the contact invariant $\underline{c}(\xi; \mathbb{A}_1)$ is the image of $\underline{c}(\xi; \mathbb{A}_0)$ under the morphism above, but of course for $-M$ instead of M .

The contact invariant is functorial also (and more importantly) with respect to Weinstein cobordisms. The following statement is a straightforward generalisation of [38, Lemma 2.11], which was a refinement of [96, Theorem 4.2] and [83, Theorem 2.3]. Plamenevskaya in [99, Theorem 4] had already proved the same result for Weinstein cobordisms coming from Weinstein fillings (i.e. where $(M_0, \xi_0) = (S^3, \xi_{st})$.)

¹Beware the typos!

Proposition 1.3.6. *if (W, ω) is a Weinstein cobordism from (M_0, ξ_0) to (M_1, ξ_1) and \mathfrak{k} is the canonical Spin^c structure on W induced by ω , then*

$$\widehat{F}_{\overline{W}, \mathfrak{s}}(c(\xi_1)) = \begin{cases} c(\xi_0) & \text{if } \mathfrak{s} = \mathfrak{k}, \text{ and} \\ 0 & \text{if } \mathfrak{s} \neq \mathfrak{k}, \end{cases}$$

where \overline{W} denote the cobordism W turned “upside-down”, i.e. seen as a cobordism from $-M_0$ to $-M_1$.

It is expected that Proposition 1.3.6 holds also for Liouville cobordisms. However, at the moment we can prove it only for Liouville cobordisms coming from Liouville fillings. The following proposition is an easy consequence of [38, Remark 2.14].

Proposition 1.3.7. *if (W, ω) is a Liouville cobordism from (S^3, ξ_{st}) to (M, ξ) and \mathfrak{k} is its canonical Spin^c structure, then*

$$\widehat{F}_{\overline{W}, \mathfrak{s}}(c(\xi)) = \begin{cases} c(\xi_{st}) \neq 0 & \text{if } \mathfrak{s} = \mathfrak{k}, \text{ and} \\ 0 & \text{if } \mathfrak{s} \neq \mathfrak{k}. \end{cases}$$

Heegaard Floer homology comes in different flavours and so far we have discussed only the simplest one. To a three-manifold M with a Spin^c structure \mathfrak{t} we can associate also the Heegaard Floer homology groups $\underline{HF}^\infty(M, \mathfrak{t}; \mathbb{A})$, $\underline{HF}^-(M, \mathfrak{t}; \mathbb{A})$ and $\underline{HF}^+(M, \mathfrak{t}; \mathbb{A})$. Among these other groups, only $\underline{HF}^+(M, \mathfrak{t}; \mathbb{A})$ will be used in this text. It satisfies all properties we have described here for $\widehat{HF}(M, \mathfrak{t}; \mathbb{A})$ and, in addition, it comes equipped with an \mathbb{A} -linear map

$$U: \underline{HF}^+(M, \mathfrak{t}; \mathbb{A}) \rightarrow \underline{HF}^+(M, \mathfrak{t}; \mathbb{A})$$

which fits into an exact triangle

$$\begin{array}{ccc} \underline{HF}^+(M, \mathfrak{t}; \mathbb{A}) & \xrightarrow{U} & \underline{HF}^+(M, \mathfrak{t}; \mathbb{A}) \\ & \searrow & \swarrow \\ & \widehat{HF}(M, \mathfrak{t}; \mathbb{A}) & \end{array} \quad (1.4)$$

The maps in this triangle also commute with the cobordism maps. The main virtue of \underline{HF}^+ over \widehat{HF} is that it is related to the invariants of four-manifolds; see [97]. The contact invariant $\underline{c}^+(\xi; \mathbb{A})$ in $\underline{HF}^+(M, \mathfrak{t}; \mathbb{A})$ is defined as the image of $\underline{c}(\xi; \mathbb{A})$ by the map in (1.4).

1.4 Sutured manifolds and Floer homology

Sutured manifolds were introduced by Gabai in [29] to construct taut foliations on three manifolds.

Definition 1.4.1. ([29, Definition 2.6]) A *sutured manifold* (M, γ) is a compact oriented three-manifold M together with a set $\gamma \subset \partial M$ of pairwise disjoint annuli $A(\gamma)$ and tori $T(\gamma)$. Each component of $A(\gamma)$ is a tubular neighbourhood of an oriented simple closed curve called *suture*. Finally every component of $\partial M \setminus \gamma$ is oriented, and its orientation must be coherent with the orientation of the sutures.

We define $R_+(\gamma)$ as the subset of $\partial M \setminus \gamma$ where the orientation agrees with the orientation induced by M on ∂M , and $R_-(\gamma)$ as the subset of $\partial M \setminus \gamma$ where the two orientations disagree. We define also $R(\gamma) = R_+(\gamma) \cup R_-(\gamma)$. We will denote the union of the sutured by Γ and define $M \setminus \Gamma = R(\Gamma) = R_+(\Gamma) \cup R_-(\Gamma)$ where $R_\pm(\Gamma)$ retracts onto $R_\pm(\gamma)$. Since we will only be concerned with sutured manifolds with $T(\gamma) = \emptyset$, Γ determines γ and we will write also (M, Γ) for (M, γ) . Sometimes we will think of sutured manifolds as manifolds with boundary, and sometimes as manifolds with boundary and corners at $\partial A(\gamma)$.

An important example of sutured manifold is the following.

Definition 1.4.2 (See [30, Definition 2.1]). The sutured manifold (M, γ) is a *product sutured manifold* if, up to diffeomorphism, $M = R \times [-1, 1]$ and $\gamma = \partial R \times [-1, 1]$ for some surface R (possibly with boundary) and $R_\pm(\gamma) = R \times \{\pm 1\}$.

In relation to contact topology and Heegaard Floer homology, it is natural to consider the more restrictive notion of balanced sutured manifold introduced by Juhász in [69].

Definition 1.4.3. A sutured manifold (M, γ) is *balanced* if

- $T(\gamma) = \emptyset$,
- M has no closed connected component,
- every connected component of ∂M intersects γ nontrivially, and
- $\chi(R_+(\gamma)) = \chi(R_-(\gamma))$.

If (M, Γ) is a balanced sutured manifold, a relative Spin^c structure \mathfrak{t} on (M, Γ) is a homology class of nowhere vanishing tangent vector fields on M which are positively transverse to $R_+(\Gamma)$, negatively transverse to $R_-(\Gamma)$, and along Γ point from $R_-(\Gamma)$ to $R_+(\Gamma)$. The set of Spin^c structures on (M, Γ) , denoted $\text{Spin}^c(M, \Gamma)$, is an affine space over $H^2(M, \partial M; \mathbb{Z})$ and, moreover, there exists a map

$$c_1 : \text{Spin}^c(M, \Gamma) \rightarrow H^2(M, \partial M; \mathbb{Z})$$

such that, for $\alpha \in H^2(M, \partial M)$, we have $c_1(\mathfrak{t} + \alpha) = c_1(\mathfrak{t}) + 2\alpha$.

Let (M, Γ) be a balanced sutured manifold, $\mathfrak{t} \in \text{Spin}^c(M, \Gamma)$ a Spin^c structure and \mathbb{A} an algebra over $\mathbb{F}[H_2(M; \mathbb{Z})]$. The *sutured Floer homology* group of (M, Γ)

with coefficients in \mathbb{A} is a finitely generated \mathbb{A} -module $\underline{SFH}(M, \Gamma, \mathfrak{t}; \mathbb{A})$ which is a diffeomorphism invariant of (M, Γ) . We will write $SFH(M, \Gamma, \mathfrak{t})$ when $\mathbb{A} = \mathbb{F}$ and $\underline{SFH}(M, \Gamma, \mathfrak{t})$ when $\mathbb{A} = \mathbb{F}[H_2(M)]$. We denote also

$$\underline{SFH}(M, \Gamma; \mathbb{A}) = \bigoplus_{\mathfrak{t} \in \text{Spin}^c(M, \partial M)} \underline{SFH}(M, \Gamma, \mathfrak{t}; \mathbb{A}).$$

As explained in [69], the Heegaard Floer homology group $\widehat{HF}(M)$ can be reinterpreted as the sutured Floer homology group $\underline{SFH}(M(1), \Gamma(1))$, where $M(1)$ is the complement of an open ball in M and $\Gamma(1)$ consists of a single connected curve in $\partial M(1) \cong S^2$.

If (M, ξ) is contact manifold with convex boundary and Γ is the dividing set of ∂M , then (M, Γ) is a balanced sutured manifold by [45]. Similarly to the close case, ξ determines a relative Spin^c structure \mathfrak{t}_ξ and, according to Honda, Kazez and Matić [58], a contact class $\underline{c}(\xi; \mathbb{A}) \in \underline{SFH}(-M, -\Gamma, \mathfrak{t}_\xi; \mathbb{A})$ which is well defined up to multiplication by invertible elements in \mathbb{A} . When $\mathbb{A} = \mathbb{F}$ we write $c(\xi)$ and when $\mathbb{A} = \mathbb{F}[H_2(M; \mathbb{Z})]$ we write $\underline{c}(\xi)$.

Remark 1.4.4. The contact class is denoted by $EH(\xi)$ in [58]. Its definition relies on the choice of a partial open book decomposition and the proof of invariance on a relative version of the Giroux correspondence. Since even less details have appeared in the relative case, I will not call the relative contact class a contact invariant. This has no consequence on the use we will make of it: in the applications it will be enough to compute $c(\xi)$ for a fixed partial open book decomposition.

In our the application of sutured Floer homology we will use the following gluing theorem, which generalises the one of Honda, Kazez and Matić from [56] to twisted coefficients.

Theorem 1.4.5 ([40, Theorem 12]). *Let (M_0, Γ_0) and (M_1, Γ_1) be balanced sutured manifolds with $M_1 \subset \text{int}(M_0)$. If ξ is a contact structure on $M_0 \setminus \text{int}(M_1)$ with convex boundary and dividing set Γ_0 on ∂M_0 and Γ_1 on ∂M_1 , then there is a map*

$$\Phi_\xi: \underline{SFH}(-M_1, -\Gamma_1) \rightarrow \underline{SFH}(-M_0, -\Gamma_0)$$

which is linear over $\mathbb{F}[H_2(M_1; \mathbb{Z})]$ with respect to the $\mathbb{F}[H_2(M_1; \mathbb{Z})]$ -module structure on $\underline{SFH}(-M_0, -\Gamma_0)$ induced by the inclusion $M_1 \hookrightarrow M_0$. Moreover, Φ_ξ satisfies the following property: if ξ_1 is a contact structure on M_1 with convex boundary and dividing set Γ_1 and ξ_0 is the contact structure on M_0 obtained by gluing ξ_1 with ξ , then

$$\Phi_\xi(\underline{c}(\xi_1)) = \underline{c}(\xi_0).$$

The same remark as before is in place here: the invariance of Φ_ξ relies on the relative Giroux correspondence. In the applications it will be enough to work with a fixed partial open book decomposition of ξ .

Chapter 2

Giroux torsion, fillability and the contact invariant

2.1 Introduction

In this chapter we explore the relations between the Ozsváth–Szabó contact invariant, Giroux torsion and symplectic fillability. Since every contact manifold with positive Giroux torsion is the result of a generalised Lutz twist, the starting point will be the following result, which was obtained in collaboration with Honda.

Theorem 2.1.1 ([40, Theorem 2]). *Let (M, ξ) be a closed, oriented, connected contact three-manifold and $T \subset M$ a pre-Lagrangian torus. If (M, ξ') is obtained from (M, ξ) by a generalised Lutz twist along T , then for every $\mathbb{F}[H_2(M; \mathbb{Z})]$ -module \mathbb{A} ,*

$$\underline{c}(\xi'; \mathbb{A}) = (e^{[T]} + 1)\underline{c}(\xi; \mathbb{A}).$$

The statement of Theorem 2.1.1 was inspired by the work of Hutchings and Sullivan [62] on the embedded contact homology of the three-torus. The proof is in two steps. In the first step we show that the effect of a generalised Lutz twist along T is the multiplication by a universal polynomial evaluated in the homology class of T . To do this, we use sutured Floer homology and Theorem 1.4.5 to localise the computation to a neighbourhood of T . In the second step we pin down the polynomial by computing the contact invariants for two contact structures of T^3 which differ by a generalised Lutz twist. To do this we construct a Weinstein cobordism W_0 from T^3 to T^3 which decreases Giroux torsion and compute the associated map in Heegaard Floer homology by embedding W_0 into an elliptic surface and using the four-dimensional invariants from [97].

Theorem 2.1.1 gives a more direct and unified explanation of some previous vanishing results which had been proved originally by more *ad hoc* arguments.

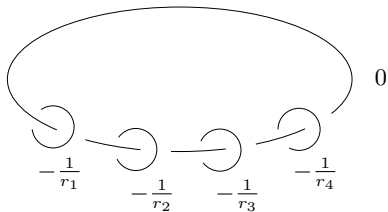

Figure 2.1: The surgery diagram defining $M(r_1, r_2, r_3, r_4)$

The following corollary is a consequence of Theorem 2.1.1 and the naturality of the contact invariant with respect to change of coefficients (Lemma 1.3.5).

Corollary 2.1.2. *If a contact manifold (M, ξ) has positive Giroux torsion, then $c(\xi) = 0$.*

This result was first conjectured in [37, Conjecture 8.3], partial results were obtained in [38, 37], where I produced the first examples of tight contact structures with trivial Heegaard Floer invariants, and by Lisca and Stipsicz in [84], and was finally proved in [41]. Together with Corollary 1.3.4, it implies the following nonfillability result, which was conjectured by Eliashberg and first proved by Gay in [34].

Corollary 2.1.3. *A contact manifold with positive Giroux torsion is not strongly symplectically fillable.*

If T is a separating torus, then $e^{[T]} - 1 = 0$. This and Theorem 1.3.3 immediately imply the following corollary. The nonfillability part, although not explicitly stated there, follows also from the argument in [34].

Corollary 2.1.4. *If (M, ξ) has positive Giroux torsion along a separating torus, then $\underline{c}(\xi) = 0$ and (M, ξ) is not weakly symplectically fillable*

On the other hand, Colin [11] and Honda, Kazez and Matić [57] have proved that on any manifold M with an incompressible torus T there exist infinitely many nonisomorphic tight contact structures with positive Giroux torsion along T . This gives large infinite families of tight contact structures with trivial Heegaard Floer contact invariants which generalise the following examples from [37].

Example 2.1.5. Let $M = M(r_1, r_2, r_3, r_4)$ be the three-manifold described by the surgery diagram in Figure 2.1 with $r_i \in \mathbb{Q} \cap (0, 1)$. From the surgery diagram it is easy to construct a Seifert fibration of M over S^2 with four singular fibres. Thus we can decompose $M = M'_0 \cup T^2 \times [0, 1] \cup M'_1$ where M'_i is a Seifert manifold which fibres over D^2 with two singular fibres. By [52, Proposition 2.2 and Section 1.2], M'_i is a surface bundle over S^1 . Let ξ'_i be a contact structure on M'_i obtained by the first half of the construction of Thurston and Winkelnkemper [110]. Thus the boundary of each M'_i is a pre-Lagrangian torus and we define

a contact structure ξ over M by gluing (M'_0, ξ'_0) and (M'_1, ξ'_1) with a suitable contact structure on $T^2 \times [0, 1]$ with positive Giroux torsion. Thus we know by Corollary 2.1.4 that $\underline{c}(\xi) = 0$. (In [37] this was shown using the explicit construction of ξ .) We can see that ξ is tight in two ways: either we observe that (M, ξ) is decomposed into universally tight pieces glued along pre-Lagrangian tori and apply Colin's gluing theorem [10, Theorem 4.2], or we exhibit a contact form for ξ whose Reeb vector field has no contractible Reeb orbits and apply Hofer's theorem [53, Theorem 1] producing a contractible Reeb orbit from an overtwisted disc.

These contact manifolds were the first examples of tight contact manifolds with trivial contact invariants for every choice of coefficients, in a somewhat cheating way because they are rational homology spheres, and therefore they do not support non trivial twisted coefficients. They were also the first known examples of universally tight contact structures which are not weakly fillable. Of course there was no reason to expect that the two notions should be related; the fact that we knew no example of universally tight but not weakly symplectically fillable contact manifold only shows the lamentable state of our understanding of three-dimensional contact topology at that time.

The following corollary gives a very partial positive answer to Conjecture 1.1.4. It follows from Theorem 2.1.1 because $\mathbb{Z}[H_2(M; \mathbb{Z})]$ is a Noetherian ring.

Corollary 2.1.6. *Let (M, ξ) be a contact three-manifold and let (M, ξ_n) , for $n \geq 0$, be the contact manifold obtained by performing n generalised Lutz twists along a pre-Lagrangian torus $T \subset M$. If $[T] \neq 0 \in H_2(M; \mathbb{Z})$ and $\underline{c}(\xi)$ is nontorsion (e.g. when (M, ξ) is weakly symplectically fillable), then*

1. ξ_n has finite torsion along T for $n \geq 0$;
2. ξ_n and ξ_m are pairwise nonisotopic for $n \neq m$.

Next we use Theorem 2.1.1 to classify the tight contact structures on the three-manifolds $-\Sigma(2, 3, 6n - 1)$, which are the three-manifolds defined by the surgery diagram in Figure 2.2. They owe their name to being diffeomorphic to the link of the polynomial $p(x, y, z) = x^2 + y^3 + z^{6n-1}$ near the singular point $(0, 0, 0)$, but with the opposite orientation. Contact structures on these manifolds have been studied for a long time. Lisca and Matić in [82] used Seiberg-Witten invariants to distinguish between contact structures defined as Legendrian surgeries on the different Legendrian realisation of the link in Figure 2.2 for $n > 1$. (see Figure 2.3). Later Etnyre and Honda [25] proved that $-\Sigma(2, 3, 5)$ supports no tight contact structure, giving the first example of such a manifold. A partial understanding of tight contact structures on $-\Sigma(2, 3, 6n - 1)$ was instrumental in exhibiting the first examples of tight (in fact, weakly symplectically fillable) contact structures with vanishing Heegaard Floer contact invariant with untwisted coefficients in [38]. Since those examples have positive Giroux torsion, that result has been superseded by Corollary 2.1.2. Finally it was proved in

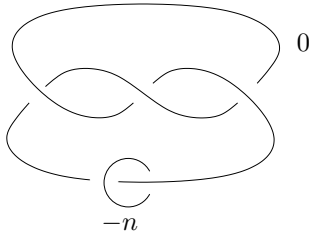

Figure 2.2: Surgery diagram for $-\Sigma(2, 3, 6n - 1)$

[36] that $-\Sigma(2, 3, 6n - 1)$ carries a strongly fillable contact structure which is not Stein fillable when $n \geq 3$, thus showing that strong and Stein fillability are different concepts in dimension three.

For any $n \geq 2$ we define

$$\mathcal{P}_n = \left\{ (i, j) \in \mathbb{Z} \times \mathbb{Z} : \begin{array}{l} 0 \leq i \leq n - 2, \\ |j| \leq n - i - 2 \text{ with } j \equiv n - i \pmod{2} \end{array} \right\}.$$

In Subsection 2.4.1 we will construct contact structures $\eta_{i,j}^n$ on $-\Sigma(2, 3, 6n - 1)$ for all $(i, j) \in \mathcal{P}_n$ by Legendrian surgery on contact structures ξ_i , with Giroux torsion i , on the three-manifold obtained by 0-framed surgery on the right-handed trefoil knot.

Proposition 2.1.7. *The contact structures $\eta_{i,j}^n$ are all strongly symplectically fillable.*

Proof. They are weakly fillable because the contact structures ξ_i are all weakly symplectically fillable and Legendrian surgery preserves weak fillability (see [26, Theorem 2.5]). Moreover $-\Sigma(2, 3, 6n - 1)$ is a homology sphere for all n , and therefore any weak symplectic filling of $(-\Sigma(2, 3, 6n - 1), \eta_{i,j}^n)$ can be deformed to a strong symplectic filling; see for example [22, Proposition 4.1]. \square

We can visualise \mathcal{P}_n (and the contact structures indexed by its elements) as a ‘‘Pascal’’ triangle with $n - 1$ rows and $(n - 2, 0)$ at its upper vertex. For example for $n = 5$ we have

$$\begin{array}{ccccccc} & & & & \eta_{3,0}^5 & & \\ & & & & & \eta_{2,1}^5 & \\ & & & \eta_{2,-1}^5 & & & \\ & & \eta_{1,-2}^5 & & \eta_{1,0}^5 & & \eta_{1,2}^5 \\ & \eta_{0,-3}^5 & & \eta_{0,-1}^5 & & \eta_{0,1}^5 & \eta_{0,3}^5 \end{array} \quad (2.1)$$

For any n , the contact structures on the bottom row (i.e. with $i = 0$) are those considered by Lisca and Matić in [82], which are obtained by Legendrian surgery on all possible Legendrian realisations of the link in Figure 2.2 (see Figure 2.3), and therefore are Stein fillable. Olga Plamenevskaya proved in [99] that their contact invariants are linearly independent in $\widehat{HF}(\Sigma(2, 3, 6n - 1))$.

Using convex surfaces it was proved in [44, Subsection 2.2], generalising an argument from [43], that every tight contact structure on $-\Sigma(2, 3, 6n - 1)$ is isotopic to $\eta_{i,j}^n$ for some $(i, j) \in \mathcal{P}_n$. Thus, to classify tight contact structures on $-\Sigma(2, 3, 6n - 1)$ it remains to show that all contact structures $\eta_{i,j}^n$ are pairwise non isotopic. This will be achieved by computing their Ozsváth–Szabó contact invariants.

Theorem 2.1.8. *The Heegaard Floer contact invariant of $\eta_{i,j}^n$ is*

$$c(\eta_{i,j}^n) = \sum_{k=0}^i (-1)^k \binom{i}{k} c(\eta_{0,j-i+2k}^n). \quad (2.2)$$

Theorem 2.1.8 can be reformulated in plain English as follows. Any $(i, j) \in \mathcal{P}_n$ determines a sub-triangle $\mathcal{P}_n(i, j) \subset \mathcal{P}_n$ with top vertex at (i, j) defined as

$$\mathcal{P}_n(i, j) = \{(k, l) \in \mathcal{P}_n : 0 \leq k \leq i \text{ and } j - k \leq l \leq j + k\}.$$

The contact invariant of $\eta_{i,j}^n$ is then a linear combination of the invariants of the contact structures parametrised by the pairs in the base of $\mathcal{P}_n(i, j)$. In order to compute the coefficients we associate natural numbers to the elements of $\mathcal{P}_n(i, j)$, starting by associating 1 to the vertex (i, j) , and going downward following the rule of the Pascal triangle. Then the numbers associated to the elements in the bottom row, taken with alternating signs, are the coefficients of the contact invariants of the corresponding contact structures in the sum in Equation (2.2).

The computation of the contact invariants of the contact structures $\eta_{i,j}^n$ is based on the computation of the contact invariant with twisted coefficients of the contact structures ξ_i , which has been made possible by Theorem 2.1.1. It might look surprising, at first sight, that one has to use twisted coefficients to compute the invariants of contact structures on a homology sphere, which of course allows no nontrivial coefficient systems. The reason of the effectiveness of twisted coefficients in this situation is twofold. On the one hand, the large indeterminacy of the contact invariant with twisted coefficients allows the invariants of different $\eta_{i,j}^n$, with n and i fixed, to be mapped to different representatives of $\underline{c}(\xi_i)$. On the other hand, the contact invariants $\underline{c}(\xi_i)$ are all nonzero and pairwise distinct for $i \geq 0$ by Theorem 2.1.1, while the “untwisted” invariants $c(\xi_i)$ vanish for $i > 0$ by Corollary 2.1.2.

Equation (2.2) and Plamenevskaya’s result imply that, for a fixed $n > 1$, the contact invariants $c(\eta_{i,j}^n)$ are pairwise distinct, and therefore the contact structures $\eta_{i,j}^n$ are pairwise non isotopic. Thus we have the following corollary.

Corollary 2.1.9. *$-\Sigma(2, 3, 6n - 1)$ admits exactly $\frac{n(n-1)}{2}$ distinct isotopy classes of tight contact structures and the contact structures $\eta_{i,j}^n$ for $(i, j) \in \mathcal{P}_n$ are a set of representatives.*

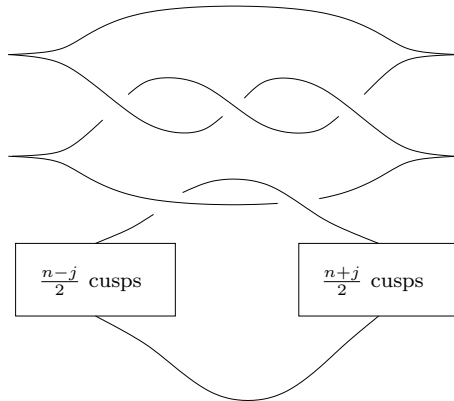

Figure 2.3: Legendrian surgery presentation of $(Y_n, \eta_{0,j}^n)$.

Finally, in Subsection 2.4.3 we will use Theorem 2.1.8 to prove the following slight generalisation of [36, Theorem 1.5], which provided the first examples of strongly fillable contact structures which are not Weinstein fillable.

Theorem 2.1.10. *The contact structures $\eta_{i,0}^n$ are not Liouville fillable for $i > 0$.*

The contact structures of Theorem 2.1.10 are those on the axis of the triangle 2.1 which lie above the bottom row. It is still an open question if all the contact structures $\eta_{i,j}^n$ with $i > 0$ are not Weinstein fillable.

The starting point for the proof of Theorem 2.1.10 is the observation that the contact structure $\eta_{i,-j}^n$ is isotopic to the conjugate of $\eta_{i,j}^n$ for all $n \geq 2$ and all $(i, j) \in \mathcal{P}_n$. In particular, the contact structures on the axis of the triangle (2.1) are isotopic to their own conjugates. This symmetry and the structure of the contact invariants $c(\eta_{i,0}^n)$ imply that a hypothetical Stein filling of $(-\Sigma(2, 3, 6n - 1), \eta_{i,0}^n)$ must contradict Proposition 1.3.7 if $i > 0$.

Bowden used the contact manifolds $(-\Sigma(2, 3, 6n - 1), \eta_{n-2,0}^n)$ (i.e. the top vertices of the triangles) as building blocks for constructing the first examples of contact three-manifolds which are Liouville fillable but not Weinstein fillable. He proved that $\eta_{n-2,0}^n$ arises as perturbation of a taut foliation on $-\Sigma(2, 3, 6n - 1)$, and it follows from Eliashberg and Thurston [24, Corollary 3.2.5] and the fact that $\Sigma(2, 3, 6n - 1)$ is a homology sphere that $(-\Sigma(2, 3, 6n - 1), \eta_{n-2,0}^n)$ is a boundary component of a Liouville manifold with disconnected boundary and that the other boundary component is $(\Sigma(2, 3, 6n - 1), \eta')$. (We don't care what contact structure η' is.) Attaching an index one Weinstein Handle between the two boundary components produces a Liouville filling of $(-\Sigma(2, 3, 6n - 1) \# \Sigma(2, 3, 6n - 1), \eta_{n-2,0}^n \# \eta')$. If $(-\Sigma(2, 3, 6n - 1) \# \Sigma(2, 3, 6n - 1), \eta_{n-2,0}^n \# \eta')$ were Weinstein fillable, it would follow from a result of Eliashberg in [20, Section 8] that both $(-\Sigma(2, 3, 6n - 1), \eta_{n-2,0}^n)$ and $(\Sigma(2, 3, 6n - 1), \eta')$ would be Weinstein fillable, contradicting Theorem 2.1.10.

2.2 A word about integer coefficients

Theorem 2.1.1 in [40] and Corollary 2.1.2 in [41] were stated and “proved” for integer coefficients. However, Massot pointed out a gap in the proofs if we consider coefficients in a ring of characteristic different from two. On the other hand, the problem disappears if we work in characteristic two.

In this section I will explain the gap and what has to be done to fix it. In order to define Floer homology over the integers (or, more generally, over rings with characteristic different from two) it is necessary to fix a coherent orientation of the moduli spaces of pseudoholomorphic strips which are counted in the differential. In the case of Heegaard Floer homology and sutured Floer homology there are $2^{b_2(M)}$ choices of coherent orientation systems for the moduli spaces, which means that Heegaard Floer homology over the integers is not uniquely defined unless M is a rational homology sphere. For a closed manifold M , one can still fix a preferred coherent orientation system by requiring that $HF^\infty(M, \mathfrak{t}) \cong \mathbb{Z}[U, U^{-1}]$ with trivial action of $H_2(M; \mathbb{Z})$ for any torsion Spin^c structure \mathfrak{t} ; see [92, Theorem 10.2]. However, in sutured Floer homology there is no infinity version, and therefore this strategy for fixing a preferred coherent orientation system is not available.

Another approach to the definition of a preferred orientation system in Heegaard Floer homology is to follow [28, Chapter 8] (or [102, Chapter 11]). In this approach coherent orientation systems are determined by Spin structures on the Heegaard tori and there is a natural candidate for a preferred Spin structure on an n -dimensional torus \mathbb{T}^n : the one which is induced by the group structure of \mathbb{T}^n . This Spin structure can be equivalently characterised as the one whose restriction to any homologically essential curve in \mathbb{T}^n does not extend to the disc. The advantage of this approach is that it applies equally well to closed manifolds and sutured manifolds. A problem is that, when we go to cobordisms, this is not the choice of Spin structure which makes the surgery sequence of [92, Theorem 9.1] exact; see [102, Theorem 1.16]. There is, however, a possible way out: in fact several choices of Spin structures can correspond to the same coherent orientation system in the sense of Ozsváth and Szabó and we expect that the surgery sequence is exact for a choice of Spin structures which induce the preferred coherent orientation system in the sense of Ozsváth and Szabó. Fixing the details of this approach to defining Heegaard Floer homology with integer coefficients is a work in very slow progress with Juhász and Zemke.

Since once a preferred orientation system on sutured Floer homology is fixed the proofs of all results of this chapter will work over the integers as they are, we write the statements in the form they will have at that point; in particular we keep writing negative signs which look silly in characteristic two.

2.3 Generalised Lutz twists and contact invariants

In this section we sketch the proof of Theorem 2.1.1. For the details we refer to [40]. First, we observe that, by the naturality of the contact invariant under change of coefficients (Lemma 1.3.5), it is enough to prove Theorem 2.1.1 for $\mathbb{A} = \mathbb{F}[H_2(M; \mathbb{Z})]$.

The first step uses Theorem 1.4.5 to localise the computation. If $T \subset M$ is a pre-Lagrangian torus, then the local model for a neighbourhood of a pre-Lagrangian torus implies that T has a neighbourhood $N_0 \cong T^2 \times [0, \pi/2]$ such that, for a suitable choice of coordinates, $\xi|_{N_0} = \ker(\sin(t)dx + \cos(t)dy)$. We define the *slope* of a closed curve in T^2 so that the leaves of the characteristic foliation of $T^2 \times \{0\}$ have slope 0 and those of the characteristic foliation of $T^2 \times \{\pi/2\}$ have slope ∞ . We perturb N_0 near its boundary to obtain $N \cong T^2 \times [0, \pi/2]$ with convex boundary and dividing set $\Gamma = \Gamma_0 \cup \Gamma_{\pi/2}$, where $\Gamma_0 \subset T^2 \times \{0\}$ and $\Gamma_{\pi/2} \subset T^2 \times \{\pi/2\}$ consist of two parallel curves each of slope 0 and ∞ respectively. The contact structure $\xi|_N$ is what is called a *basic slice* in [54].

By [40, Lemma 13], the sutured Floer homology of $(N, \Gamma_0 \cup \Gamma_1)$ is $SFH(N, \Gamma_0 \cup \Gamma_1) = \mathbb{A} \oplus \mathbb{A} \oplus \mathbb{A} \oplus \mathbb{A}$ with each summand in a different relative Spin^c structure and moreover the invariant of a basic slice generates the summand corresponding to its Spin^c structure. We can perform the Lutz twist along T supported inside $\text{int}(N)$ so that ξ and ξ' coincide on $M \setminus \text{int}(N)$ and therefore ∂N is still convex with dividing set $\Gamma_0 \cup \Gamma_1$. Since $\xi|_N$ and $\xi'|_N$ are homotopic relative to the boundary, $\underline{c}(\xi'|_N)$ and $\underline{c}(\xi|_N)$ belong to the same Spin^c summand, and therefore $\underline{c}(\xi'|_N) = p(t)\underline{c}(\xi|_N)$ for some Laurent polynomial $p(t)$ which is well defined up to multiplication by integer powers of t . Thus Theorem 1.4.5 implies that $\underline{c}(\xi') = p(e^{[T]})\underline{c}(\xi)$.

The polynomial $p(t)$ is independent of ξ because $(N, \xi|_N)$ and $(N, \xi'|_N)$ are universal models for the neighbourhood of a pre-Lagrangian torus before and after a generalised Lutz twist. For this reason we can determine $p(t)$ by computing an explicit models. We recall the contact structures

$$\xi_n = \ker(\sin(2\pi n z)dx + \cos(2\pi n z)dy)$$

on T^3 for $n \geq 1$. The contact structure ξ_1 is Weinstein fillable because it is the canonical contact structure on the unit cotangent bundle of T^2 . Up to isotopy, ξ_{n+1} is obtained from ξ_n by performing a generalised Lutz twist.

Let $\omega \in H^2(T^3; \mathbb{Z})$ be the cohomology class of the closed form $dx \wedge dy$. We denote by $\underline{HF}^+(T^3; \mathbb{A}_\omega)^{\text{free}}$ the quotient of $\underline{HF}^+(T^3; \mathbb{A}_\omega)$ by the subgroup of \mathbb{A}_ω -torsion elements. It follows from [40, Proposition 19] that $\underline{HF}^+(T^3; \mathbb{A}_\omega)^{\text{free}} \cong \mathbb{A}_\omega$ and is concentrated in degree $-\frac{1}{2}$. Moreover $\underline{c}(\xi_1; \mathbb{A}_\omega)$ has nonzero image $\underline{c}(\xi_1; \mathbb{A}_\omega)^{\text{free}}$ in $\underline{HF}^+(T^3; \mathbb{A}_\omega)^{\text{free}}$. Thus $\underline{c}(\xi_n; \mathbb{A}_\omega)^{\text{free}} = p(t)^{n-1}\underline{c}(\xi_1; \mathbb{A}_\omega)^{\text{free}}$.

Let $a, b \subset T^2$ be two simple closed curves intersecting transversely at one point and let τ_a and τ_b be the corresponding positive Dehn twists. It is well known

that $(\tau_a \tau_b)^6 = id$ in the mapping class group of T^2 . After turning Dehn twists into Legendrian surgeries, we obtain a Stein cobordism W_0 with (T^3, ξ_{n+1}) at the negative end and (T^3, ξ_n) at the positive end for every $n \geq 2$. We can regard W_0 also as the total space of a Lefschetz fibration over the annulus with fibre T^2 and twelve singular fibres corresponding to the twelve Dehn twists in $(\tau_a \tau_b)^6$. Let Ω be a symplectic form on W_0 compatible with the Lefschetz fibration and normalised so that its cohomology class restricts to ω on the two boundary components. Let

$$\underline{F}_{W_0; \mathbb{A}_\omega, free}^+ : \underline{HF}^+(T^3; \mathbb{A}_\omega)^{free} \rightarrow \underline{HF}^+(T^3; \mathbb{A}_\omega)^{free}$$

the map induced by the upside-down cobordism. Then

$$\underline{F}_{W_0; \mathbb{A}_\omega, free}^+(\underline{c}(\xi_n; \mathbb{A}_\omega)^{free}) = \underline{c}(\xi_{(n+1)}; \mathbb{A}_\omega)^{free}.$$

To conclude the proof of the theorem, it is enough to show that $\underline{F}_{W_0; \mathbb{A}_\omega, free}^+$ acts as the multiplication by $t-1$ on $\underline{HF}^+(T^3; \mathbb{A}_\omega)^{free} \cong \mathbb{A}_\omega \cong \mathbb{F}[t, t^{-1}]$. This can be done by comparing the four-dimensional invariants of the elliptic surfaces $E(n)$, which can be described as the concatenation of n copies of the cobordism W_0 with two copies of $T^2 \times D^2$ glued at the ends; see [40, Section 4].

2.4 Contact structures on the Brieskorn spheres $-\Sigma(2, 3, 6n - 1)$

In this section we define the contact structures $\eta_{i,j}^n$ and sketch the proofs of Theorem 2.1.8 and Theorem 2.1.10.

2.4.1 Construction of the tight contact structures

We introduce the notation

$$Y_n = -\Sigma(2, 3, 6n - 1)$$

and, coherently with the standard surgery convention, we define Y_∞ to be the three-manifold obtained by 0-surgery on the right-handed trefoil knot. We describe Y_∞ as a quotient of $T^2 \times \mathbb{R}$ (with coordinates (x, y) on T^2 and t on \mathbb{R}):

$$Y_\infty = T^2 \times \mathbb{R} / (\mathbf{v}, t) = (A\mathbf{v}, t - 1)$$

where $A: T^2 \rightarrow T^2$ is induced by the matrix $\begin{pmatrix} 1 & 1 \\ -1 & 0 \end{pmatrix}$. In [47] Giroux constructed a family of weakly symplectically fillable contact structures ξ_i on Y_∞ for $i \geq 0$ as follows. For any $i \geq 0$, fix a function $\varphi_i: \mathbb{R} \rightarrow \mathbb{R}$ such that:

- (1) $\varphi_i'(t) > 0$ for any $t \in \mathbb{R}$, and
- (2) $(2i + 1)\pi \leq \sup_{t \in \mathbb{R}}(\varphi_i(t + 1) - \varphi_i(t)) < 2(i + 1)\pi$.

By condition (1) the 1-form

$$\alpha_i = \sin(\varphi_i(t))dx + \cos(\varphi_i(t))dy$$

defines a contact structure $\tilde{\xi}_i = \ker \alpha_i$ on $T^2 \times \mathbb{R}$. Moreover it is possible to choose φ_i such that the contact structure $\tilde{\xi}_i$ is invariant under the action $(\mathbf{v}, t) \mapsto (A\mathbf{v}, t - 1)$ and therefore defines a contact structure ξ_i on Y_∞ . The following proposition was proved by Giroux.

Proposition 2.4.1 ([47, Proposition 2]). *For any fixed integer $i \geq 0$ the contact structure ξ_i is tight, and its isotopy class does not depend on the chosen function φ_i .*

For every $i \geq 1$ the contact structure ξ_i is obtained by performing $n - 1$ generalised Lutz twists on ξ_0 . Moreover, from the classification of tight contact structures on torus bundles of Giroux and Honda [48, 55] it is easy to see that the contact structure ξ_0 is obtained by Legendrian surgery on S^3 with the standard contact structure.

The knot

$$F = \{\mathbf{0}\} \times \mathbb{R} / (\mathbf{0}, t) = (\mathbf{0}, t - 1) \subset Y_\infty$$

is Legendrian with respect to ξ_i for any i .

Definition 2.4.2. For any $(i, j) \in \mathcal{P}_n$ the contact manifold $(Y_n, \eta_{i,j}^n)$ is obtained by Legendrian surgery on (Y_∞, ξ_i) along a Legendrian knot $F_{i,j}$ which is obtained by applying $\frac{n-i+j-2}{2}$ positive stabilisations and $\frac{n-i-j-2}{2}$ negative stabilisations to F .

To show that the underline three-manifold is Y_n we observe that, if Y_∞ is identified with the 0-surgery on the right-handed trefoil knot, then F corresponds to a meridian, and the framing on F induced by the contact structure ξ_i corresponds to the framing $-i - 1$ on the meridian. See [38, Lemma 3.5] for more details.

In the computation of the contact invariants we will need the homotopy invariants of the contact structures ξ_i and $\eta_{i,j}^n$. For every $i \geq 0$ the canonical Spin^c structure \mathfrak{t}_{ξ_i} is the unique Spin^c structure on Y_∞ with trivial first Chern class, which is also the unique Spin^c structure for which $\widehat{HF}(-Y_\infty, \mathfrak{t}) \neq 0$ by the adjunction inequality [92, Theorem .1]. The three-dimensional homotopy invariants of the contact structures ξ_i and $\eta_{i,j}^n$ have been computed in [44, Lemma 4.7] and [38, Theorem 3.12] respectively. For all n, i and j their values are

$$d(\xi_i) = -\frac{1}{2}, \quad d(\eta_{i,j}^n) = -1. \tag{2.3}$$

2.4.2 Computation of the contact invariants

In this subsection we prove Theorem 2.1.8. First we recall the relevant Heegaard Floer homology groups. By Equation (2.3) $c(\xi_i)$ has degree $\frac{1}{2}$ and $c(\eta_{i,j}^n)$ has degree 1. Let $T \subset Y_\infty$ a generator of $H_2(Y_\infty; \mathbb{Z}) \cong \mathbb{Z}$ and take $\omega \in H^2(Y_\infty; \frac{1}{2}\mathbb{Z})$ such that $\langle \omega, T \rangle = 1$. Then by [44, Lemma 4.9]

$$\widehat{HF}_{\frac{1}{2}}(-Y_\infty; \mathbb{A}_\omega) \cong \mathbb{A}_\omega \cong \mathbb{F}[t^{1/2}, t^{-1/2}]$$

and by [89, Section 8.1], together with the exact triangle relating HF^+ and \widehat{HF} ,

$$\widehat{HF}_1(-Y_n) \cong \mathbb{F}^{n-1}.$$

Moreover, by [99, Section 3] the contact invariants $c(\eta_{0,-n+2}^n), \dots, c(\eta_{0,n-2}^n)$ form a basis of $\widehat{HF}_1(-Y_n)$. We omit the Spin^c structures because both groups are nontrivial only in one.

Legendrian surgery on the trefoil knot in Figure 2.3 induces a Weinstein cobordism from (S^3, ξ_{st}) to (Y_∞, ξ_0) and we denote by V_∞ the underlying smooth cobordism. Similarly Legendrian surgery on $F_{i,j}$ induces a Weinstein cobordism from (Y_∞, ξ_i) to $(Y_n, \eta_{i,j}^n)$ and we denote by V_n the underlying smooth cobordism, which is the same for all $(i, j) \in \mathcal{P}_n$ because the curves $F_{i,j}$ are all smoothly isotopic. We omit the Weinstein structure from the notation because the cobordism maps in Heegaard Floer homology depend on it only through the canonical Spin^c structure, and on the cobordisms V_n and V_∞ there is a unique choice for it because the restriction maps $\text{Spin}^c(V_n) \rightarrow \text{Spin}^c(Y_\infty)$ and $\text{Spin}^c(V_\infty) \rightarrow \text{Spin}^c(Y_\infty)$ are isomorphisms. We call Ω the extension of $\omega \in H^2(Y_\infty; \frac{1}{2}\mathbb{Z})$ to both V_∞ and V_n . Then, by Proposition 1.3.2 and 1.3.6, for some representatives of $\widehat{F}_{V_\infty; \Omega}$ and $\widehat{F}_{V_n; \Omega}$ we have

$$\widehat{F}_{V_\infty; \Omega}(\widehat{F}_{V_n; \Omega}(c(\eta_{0,j}^n))) = t^{j/2}. \quad (2.4)$$

See [44, Lemma 4.12] for the details of the computation. Equation (2.4) implies that we can identify $\widehat{HF}_{\frac{1}{2}}(Y_\infty; \mathbb{A}_\omega) \cong \mathbb{F}[t^{1/2}, t^{-1/2}]$ so that $c(\xi_0) = 1$ and

$$\widehat{F}_{V_n; \Omega}(c(\eta_{0,j}^n)) = t^{j/2} \quad (2.5)$$

up to multiplication by powers of $t^{\pm 1/2}$.

Remark 2.4.3. Equation (2.5) shows that the indeterminacy of the contact invariant is intrinsic and unavoidable.

The topological input in the proof of Theorem 2.1.8 is the existence of a link $\mathcal{C} \subset Y_\infty$ which is Legendrian for all contact structures ξ_i and such that Legendrian surgery on it takes the contact manifold (Y_∞, ξ_{i+1}) to (Y_∞, ξ_i) for all $i \geq 0$. We call W_∞ the cobordism associated to this surgery. The link \mathcal{C} is constructed

in [44, Section 4.1] using open book decompositions. It is related to the link producing the cobordism W_0 which was used in the proof of Theorem 2.1.1 but different, as that link is Legendrian only starting from ξ_2 . It is possible to use W_0 instead of W_∞ in proof of Theorem 2.1.8 (at least with coefficients in \mathbb{F}): the only difference is that the case $n = 3$ has to be treated separately. This is implicitly done in the proofs of [38, Theorem 1.1] and [36, Theorem 2.4].

We can regard \mathcal{C} as a Legendrian link in each $(Y_{n+1}, \eta_{i+1,j}^{n+1})$. The cobordism induced by Legendrian surgery on \mathcal{C} , denoted by W_n , then goes from $(Y_{n+1}, \eta_{i+1,j}^{n+1})$ at the negative end to $(Y_n, \eta_{i,j}^n)$ at the positive end. These cobordisms satisfy

$$W_\infty \cup_{Y_\infty} V_n = V_{n+1} \cup_{Y_{n+1}} W_n$$

and moreover the homology class $\omega \in H^2(Y_\infty; \frac{1}{2}\mathbb{Z})$ extends to W_∞ , V_n and V_{n+1} . Since there is no risk of confusion, we will call Ω any of these extensions. If we choose representatives of $\widehat{F}_{V_n;\Omega}$ and $\widehat{F}_{V_{n+1};\Omega}$ so that Equation (2.5) holds and of $\widehat{F}_{W_\infty;\Omega}$ so that it is the multiplication by $t^{\frac{1}{2}} - t^{-\frac{1}{2}}$, then the diagram

$$\begin{array}{ccc} \widehat{HF}_1(-Y_n) & \xrightarrow{\widehat{F}_{W_n}} & \widehat{HF}_1(-Y_{n+1}) \\ \downarrow \widehat{F}_{V_n;\Omega} & & \downarrow \widehat{F}_{V_{n+1};\Omega} \\ \widehat{HF}_{\frac{1}{2}}(-Y_\infty) & \xrightarrow{\widehat{F}_{W_\infty;\Omega}} & \widehat{HF}_{\frac{1}{2}}(-Y_\infty) \end{array} \quad (2.6)$$

is commutative by [44, Lemma 4.13].

We can compute $c(\eta_{1,j}^{n+1})$ by the the commutativity of Diagram 2.6: in fact

$$\widehat{F}_{V_{n+1};\Omega}(c(\eta_{1,j}^{n+1})) = \widehat{F}_{W_\infty;\Omega}(\widehat{F}_{V_n;\Omega}(c(\eta_{0,j}^n))) = t^{(j+1)/2} - t^{(j-1)/2},$$

and therefore

$$c(\eta_{1,j}^{n+1}) = c(\eta_{0,j+1}^{n+1}) - c(\eta_{0,j-1}^{n+1}) \quad (2.7)$$

because the map $\widehat{F}_{V_{n+1};\Omega}$ is injective.

Theorem 2.1.8 now follows by induction on n . The initial step is $n = 2$; since there is a unique tight contact structure on Y_2 there is nothing to prove in this case. Now we assume that Formula (2.2) holds for the tight contact structures on Y_n , for some n , and we prove that this implies that Formula (2.2) holds for the tight contact structures on Y_{n+1} . From the surgery construction we have

$$\widehat{F}_{W_n}(c(\eta_{i,j}^n)) = c(\eta_{i+1,j}^{n+1}),$$

which means that \widehat{F}_{W_n} maps the ‘‘Pascal’’ triangle (2.1) for Y_n to the part of the ‘‘Pascal’’ triangle for Y_{n+1} which lies above the bottom row. On Y_{n+1} the

induction hypothesis gives the following expression for the contact invariants of $\eta_{i,j}^{n+1}$, for $i \geq 1$, in terms of the contact invariants of $\eta_{1,j}^{n+1}$:

$$c(\eta_{i+1,j}^{n+1}) = \sum_{k=0}^i (-1)^k \binom{i}{k} c(\eta_{1,j-i+2k}^{n+1}). \quad (2.8)$$

If we substitute $c(\eta_{1,j}^{n+1})$ in Equation 2.8 with the right-hand side of Equation 2.7 and apply the recursive definition of the binomial coefficients, we obtain Equation (2.2) for $n + 1$, and therefore we have proved Theorem 2.1.8.

2.4.3 Contact structures without Liouville fillings

In this Subsection we will sketch the proof of Theorem 2.1.10. For the details we refer to [36]. The set of oriented contact structures and the set of Spin^c structures on a three-manifold M both admit a natural involution called *conjugation*. For a contact structure ξ on M , the conjugated $\bar{\xi}$ is the contact structure obtained from ξ by inverting the orientation of the planes. A Spin^c structure on a three-manifold can be seen as a nonsingular vector field up to homotopy outside a ball and thus, if \mathfrak{t} is represented by a vector field v , then the conjugate $\bar{\mathfrak{t}}$ is represented by the vector field $-v$. The two notions are obviously related: in fact $\mathfrak{t}_{\bar{\xi}} = \bar{\mathfrak{t}}_{\xi}$.

There is an involution $\mathfrak{J}: \widehat{HF}(M, \mathfrak{t}) \rightarrow \widehat{HF}(M, \bar{\mathfrak{t}})$ defined in [92, Theorem 2.4]. We recall that the isomorphism \mathfrak{J} preserves the \mathbb{Q} -grading of the Heegaard–Floer homology groups when $c_1(\mathfrak{t})$ is a torsion cohomology class, and is a natural transformation in the following sense.

Proposition 2.4.4. ([97, Theorem 3.6]) *Let (W, \mathfrak{s}) be a Spin^c -cobordism between (M_1, \mathfrak{t}_1) and (M_2, \mathfrak{t}_2) . Then the diagram*

$$\begin{array}{ccc} \widehat{HF}(M_1, \mathfrak{t}_1) & \xrightarrow{\widehat{F}_{W, \mathfrak{s}}} & \widehat{HF}(M_2, \mathfrak{t}_2) \\ \downarrow \mathfrak{J} & & \downarrow \mathfrak{J} \\ \widehat{HF}(M_1, \bar{\mathfrak{t}}_1) & \xrightarrow{\widehat{F}_{W, \bar{\mathfrak{s}}}} & \widehat{HF}(M_2, \bar{\mathfrak{t}}_2) \end{array}$$

commutes.

The contact invariant behaves well with respect to conjugation.

Lemma 2.4.5. ([38, Theorem 2.10]). *If (Y, ξ) is a contact manifold, then*

$$c(\bar{\xi}) = \mathfrak{J}(c(\xi)).$$

As a corollary, we obtain a strong restriction on the Liouville fillings of self-conjugate contact structures.

Proposition 2.4.6. *If (M, ξ) is a contact manifold such that $\bar{\xi}$ is isotopic to ξ and W is a Liouville filling of (M, ξ) with canonical Spin^c structure \mathfrak{k} , then $\mathfrak{k} = \bar{\mathfrak{k}}$.*

Proof. By Lemma 2.4.5 $\mathfrak{J}(c(\xi)) = c(\xi)$. If we regard W as a Liouville cobordism from (S^3, ξ_{st}) to (M, ξ) , then Lemma 2.4.4 implies that $\widehat{F}_{\overline{W}, \mathfrak{k}}(c(\xi)) = \widehat{F}_{\overline{W}, \bar{\mathfrak{k}}}(c(\xi))$ because \mathfrak{J} acts trivially on $\widehat{HF}(S^3)$. Finally, Proposition 1.3.7 implies that $\mathfrak{k} = \bar{\mathfrak{k}}$. \square

The following lemma, whose proof is almost immediate from the explicit construction of the contact structures $\eta_{i,j}^n$, is the main geometric input in the proof of Theorem 2.1.10.

Lemma 2.4.7 ([38, Proposition 3.8]). *For all $n \geq 0$ and all $(i, j) \in \mathcal{P}_n$ the contact structure $\eta_{i,j}^n$ is isotopic to the conjugate of $\eta_{i,-j}^n$.*

Proof of Theorem 2.1.10. Let W be a hypothetical Liouville filling of $(Y_n, \eta_{i,0}^n)$ with $i > 0$ and let \mathfrak{k} be its canonical Spin^c structure. By Lemma 2.4.7 $\bar{\eta}_{i,0}^n$ is isotopic to $\eta_{i,0}^n$. Then by Proposition 2.4.6 $\bar{\mathfrak{k}} = \mathfrak{k}$.

Proposition 2.4.4, Lemma 2.4.7 and $\bar{\mathfrak{k}} = \mathfrak{k}$ imply that $\widehat{F}_{\overline{W}, \mathfrak{k}}(c(\eta_{i,j}^n)) = \widehat{F}_{\overline{W}, \mathfrak{k}}(c(\eta_{i,-j}^n))$. Now we compute $\widehat{F}_{\overline{W}, \mathfrak{k}}(c(\eta_{i,0}^n))$ for $i \geq 1$ using 2.1.8: if n is odd, then the expression of $c(\eta_{i,0}^n)$ has an even number of terms, which cancel two by two, and therefore $\widehat{F}_{\overline{W}, \mathfrak{k}}(c(\eta_{i,0}^n)) = 0$, contradicting Proposition 1.3.7. If n is even, then $(i, 0) \in \mathcal{P}_n$ if and only if i is even and the expression of $c(\eta_{i,0}^n)$ has an odd number of terms which cancel two by two except for the central one, so $\widehat{F}_{\overline{W}, \mathfrak{k}}(c(\eta_{i,0}^n)) = (-1)^k \binom{2k}{k}$ for $2k = i$. Since $\binom{2k}{k}$ is even for $k \geq 1$ we obtain $\widehat{F}_{\overline{W}, \mathfrak{k}}(c(\eta_{i,0}^n)) = 0$ also when n is even, contradicting Proposition 1.3.7 again. \square

Chapter 3

Detecting fibred knots

3.1 Introduction

We recall some basic terminology in knot theory. If $K \subset S^3$ is a knot, a *Seifert surface* for K is an embedded connected and oriented surface $\Sigma \subset S^3$ such that $\partial\Sigma = K$. The *genus* of a knot K , denoted $g(K)$, is the smallest genus of a Seifert surface of K . It is easy to see that $g(K) = 0$ if and only if K is the trivial knot. A knot K is *fibred* if there exists a locally trivial fibration $S^3 \setminus K \rightarrow S^1$. The closure of each fibre is a Seifert surface with smallest genus. The trivial knot is fibred and the only fibred knots¹ of genus one are the trefoil knots and the figure eight knot. For any $g > 1$ there are infinitely many fibred knots of genus g , but they remain sparse.

Knot Floer homology is an invariant for null-homologous knots in three-manifolds introduced independently by Ozsváth and Szabó in [91] and by Rasmussen in [101]. It can be regarded as a relative version of Heegaard Floer homology. For a knot K in S^3 — the only case we consider here — and any integer d the knot Floer homology group $\widehat{HFK}(K, d)$ is a finite dimensional graded vector space over \mathbb{F} . (A lift to integer coefficients is also possible, but we won't consider it.)

Knot Floer homology can be seen as a categorification of the Alexander polynomial in the sense that

$$\sum_{d=-\infty}^{+\infty} \chi(\widehat{HFK}(K, d))T^d = \Delta_K(T) \quad (3.1)$$

where $\Delta_K(T)$ denotes the symmetrised Alexander polynomial of K . However the groups $\widehat{HFK}(K, d)$, and in particular the bottom non trivial group, contain more information than just the Alexander polynomial, as the following results show.

¹Here we mean knots up to isotopy. It would be more precise to say *knot types*, but we will abuse the terminology because there is no real risk of confusion.

Theorem 3.1.1. ([90, Theorem 1.2]) *Let K be a knot in S^3 . Then*

$$g(K) = \max \{d \in \mathbb{Z} : \widehat{HFK}(K, -d) \neq 0\}.$$

Theorem 3.1.2. (See [96, Theorem 1.1]) *Let K be a knot in S^3 with genus g . If K is a fibred knot, then $\widehat{HFK}(K, -g) = \mathbb{F}$.*

In this chapter we sketch the proof of the following partial converse to Theorem 3.1.2.

Theorem 3.1.3 ([39, Theorem 1.4]). *Let K be a genus-one knot in S^3 . If $\widehat{HFK}(K, -1) = \mathbb{F}$, then K is fibred.*

Remark 3.1.4. Sometimes, and in particular in [39], these results are stated for $\widehat{HFK}(K, g)$. The two formulations are equivalent because knot Floer homology satisfies the symmetry $\widehat{HFK}(K, d) \cong \widehat{HFK}(K, -d)$ for all $d \in \mathbb{Z}$.

Since the only fibred knots of genus one are the trefoil knots and the figure-eight knot, which have nonisomorphic knot Floer homology groups, Theorem 3.1.3 implies the following corollary.

Corollary 3.1.5. *Knot Floer homology detects the trefoil knots and the figure-eight knot.*

Ozsváth and Szabó in [95] proved that if a rational surgery on a knot $K \subset S^3$ produces the Poincaré homology sphere $\Sigma(2, 3, 5)$, then K has the same Heegaard Floer homology of the left-handed trefoil knot. Thus, corollary 3.1.5 implies the following corollary.

Corollary 3.1.6. *If a rational surgery on a knot $K \subset S^3$ produces the Poincaré homology sphere $\Sigma(2, 3, 5)$, then K is the left-handed trefoil knot.*

This result was conjectured by Kirby in a remark after Problem 3.6(D) of his list [72] and by Zhang in [113]. Corollary 3.1.5 has also been used by Ozsváth and Szabó to prove that the trefoil knot and the figure-eight knot are determined by their Dehn surgeries [98].

The proof of Theorem 3.1.3 was inspired by the proof of Theorem 3.1.1 and by a nonfibredness criterion of Gabai; see Lemma 3.2.11. Its strategy is the following. From a genus-one knot K we construct a closed three manifold M with a genus two closed surface $\Sigma \subset M$ such that

- K is fibred if and only if M fibres over S^1 and Σ is a fibre, and
- $\widehat{HFK}(K, -1) \cong \bigoplus_{\langle c_1(t), [\Sigma] \rangle = -2} HF^+(M, t)$.

We will denote $HF^+(M, -1) = \bigoplus_{\langle c_1(\mathfrak{t}), [\Sigma] \rangle = -2} HF^+(M, \mathfrak{t})$.

If K is not fibred, we construct two taut foliations \mathcal{F}_+ and \mathcal{F}_- on M from two sutured hierarchies in which the first cutting surface is Σ and the second cutting surfaces S_+ and S_- satisfy $g(S_{\pm}) > 0$ and are, morally speaking, the same surface with opposite orientations.

Then we perturb \mathcal{F}_+ and \mathcal{F}_- to contact structures ξ_+ and ξ_- as in [24]. The contact invariants $c^+(\xi_+)$ and $c^+(\xi_-)$ belong to $HF^+(M, -1)$. We proved that they are linearly independent by showing that (M, ξ_+) and (M, ξ_-) can be obtained by Legendrian surgery on contact manifolds (M', ξ'_+) and (M', ξ'_-) such that the contact invariants $c(\xi'_+)$ and $c(\xi'_-)$ are both nontrivial and belong to different Spin^c structures. The main property of M' is that S_{\pm} become closed surfaces and therefore we can evaluate the Euler classes of ξ'_+ and ξ'_- on them. If W is the cobordism induced by the surgery, then $F_W^+(c^+(\xi_{\pm})) = c^+(\xi'_{\pm})$, and therefore $c^+(\xi_+)$ and $c^+(\xi_-)$ are linearly independent. This shows that $\dim \widehat{HFK}(K, -1) \geq 2$.

Theorem 3.1.3 was generalised to knots of higher genus and in more general three-manifolds by Ni in [88]. For a wide class of knots his proof follows the strategy of the proof of Theorem 3.1.3, and then he proves gluing formulas for knot Floer homology and uses them to reduce the remaining cases to the ones he has already considered. Finally Juhász in [70] gave a simpler proof based on sutured Floer homology: given a nonfibred knot of genus g , he constructs two sutured hierarchies in the knot complement similar to those which are constructed in [39] and [88], but uses the sutured Floer homology techniques he developed to produce two linearly independent elements in $\widehat{HFK}(K, -g)$ bypassing taut foliations and contact structures.

3.2 Sutured Hierarchies

In this section we will consider only sutured manifolds (M, γ) with $T(\gamma) = \emptyset$ (i.e. without toric components). Unlike in the case of balanced sutured manifolds, we allow connected components of ∂M without sutures. The condition $\chi(R_+(\gamma)) = \chi(R_-(\gamma))$ is not required *a priori*, but will be satisfied *a posteriori* by all sutured manifolds we will construct.

Definition 3.2.1 ([29, Definition 2.2]). Let S be a compact oriented surface $S = \bigcup_{i=1}^n S_i$ with all S_i connected. We define the *norm* of S to be

$$x(S) = \sum_{i: \chi(S_i) < 0} -\chi(S_i).$$

Definition 3.2.2. ([29, Definition 2.4].) Let S be a properly embedded oriented surface in the sutured manifold (M, ξ) . We say that S is *norm minimising* in $H_2(M, \gamma)$ if $\partial S \subset \gamma$, S is incompressible, and its norm $x(S)$ is minimal in the homology class of S in $H_2(M, \gamma)$.

If S realises the minimal norm in its homology class and all its connected components have negative Euler characteristic, then it is incompressible.

Definition 3.2.3. ([29, Definition 2.10].) A sutured manifold (M, γ) is *taut* if $R(\gamma)$ is norm minimising in $H_2(M, \gamma)$.

Example 3.2.4. Product sutured manifolds are taut.

We will give the following definition only in the simpler case when no component of γ is a torus, because this is the case we are interested in.

Definition 3.2.5. ([29, Definition 3.1] and [31, Correction 0.3].) Let (M, γ) be a sutured manifold with $T(\gamma) = \emptyset$, and let S be a properly embedded oriented surface in M such that:

1. no component of S is a disc with boundary in $R(\gamma)$,
2. no component of ∂S bounds a disc in $R(\gamma)$,
3. for every component λ of $\partial S \cap \gamma$, one of the following holds:
 - (a) λ is a non-separating properly embedded arc in γ , or
 - (b) λ is a simple closed curve isotopic to a suture in $A(\gamma)$.

Then S defines a *sutured manifold decomposition*

$$(M, \gamma) \xrightarrow{S} (M', \gamma')$$

where $M' = M \setminus S$ and

$$\begin{aligned} \gamma' &= (\gamma \cap M') \cup \nu(S_+ \cap R_-(\gamma)) \cup \nu(S_- \cap R_+(\gamma)), \\ R_+(\gamma') &= ((R_+(\gamma) \cap M') \cup S_+) \setminus \text{int}(\gamma'), \\ R_-(\gamma') &= ((R_-(\gamma) \cap M') \cup S_-) \setminus \text{int}(\gamma'), \end{aligned}$$

where S_+ and S_- are the portions of $\partial M'$ corresponding to S where the normal vector to S points respectively out of or into $\partial M'$.

A taut sutured manifold decomposition is a sutured manifold decomposition $(M, \gamma) \xrightarrow{S} (M', \gamma')$ such that both (M, γ) and (M', γ') are taut sutured manifolds.

Definition 3.2.6. ([29, Definition 4.1]) A *sutured manifold hierarchy* is a sequence of taut sutured manifold decompositions

$$(M_0, \gamma_0) \xrightarrow{S_1} (M_1, \gamma_1) \rightsquigarrow \dots \xrightarrow{S_n} (M_n, \gamma_n)$$

where (M_n, γ_n) is a product sutured manifold.

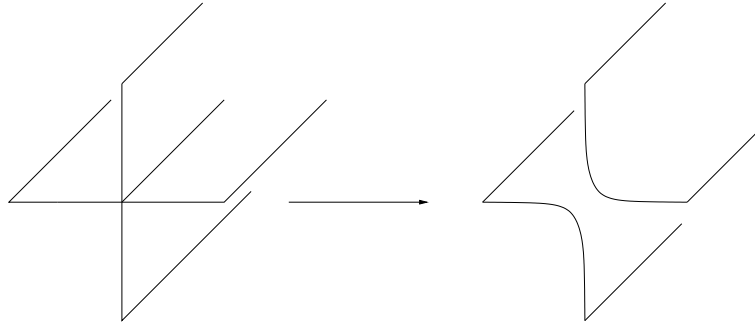

Figure 3.1: Cut-and-paste surgery

The main results in sutured manifold theory are that for any taut sutured manifold (M, γ) there is a sutured manifold hierarchy starting from (M, γ) [29, Theorem 4.2], and that we can construct a taut foliation on (M, γ) from a sutured manifold hierarchy starting from (M, γ) such that $R(\gamma)$ is union of leaves [29, Theorem 5.1]. Thus sutured manifold theory translates the problem about the existence of taut foliations into a finite set of combinatorial data. The particular result we will use in our applications is the following.

Proposition 3.2.7. *Let M be a closed, connected, irreducible, orientable three-manifold, and let Σ be a genus minimising connected surface representing a non-trivial class in $H_2(M; \mathbb{Q})$. Denote by (M_1, γ_1) the taut sutured manifold where $M_1 = M \setminus \Sigma$ and $\gamma_1 = \emptyset$. If $g(\Sigma) > 1$ and there is a taut sutured manifold decomposition*

$$(M_1, \emptyset) \xrightarrow{S} (M_2, \gamma_2)$$

then M admits a smooth taut foliation \mathcal{F} such that

1. Σ is a closed leaf,
2. \mathcal{F} is a product foliation in a neighbourhood of Σ , and
3. $e(\mathcal{F}, S) = \chi(S)$, where $e(\mathcal{F}, S)$ denotes the relative Euler class of $T\mathcal{F}$ evaluated on S .

Remark 3.2.8. A properly embedded surface S in $M_1 = M \setminus \Sigma$ gives a taut sutured manifold decomposition

$$(M_1, \gamma_1) \xrightarrow{S} (M_2, \gamma_2)$$

if for translates Σ'_+ and Σ'_- of the boundary components Σ_+ and Σ_- of $M \setminus \Sigma$ the surfaces $S + \Sigma'_+$ and $S + \Sigma'_-$ obtained by cut-and-paste surgery (see Figure 3.1) are norm minimising in $H_2(M_1, \partial S)$. In fact $S + \Sigma'_+$ and $S + \Sigma'_-$ are isotopic to $R_+(\gamma_2)$ and to $R_-(\gamma_2)$ respectively, and being norm minimising in M_1 clearly implies being norm-minimising in the smaller manifold $M_2 = M_1 \setminus S$.

We end this section with a digression into the detection of product sutured manifolds. We won't need these results, but they were the source of inspiration for Lemma 3.3.1.

Definition 3.2.9 ([31, Definition 0.1]). Let (M, γ) be a sutured manifold. A *product annulus* A in (M, γ) is a properly embedded annulus $A \subset M$ such that one boundary component of A is contained in $R_+(\gamma)$ and the other one in $R_-(\gamma)$. A *product disc* D in (M, γ) is a properly embedded disc $D \subset M$ such that $|\pi_0(\partial D \cap \gamma)| = 2$ and each component of $\partial D \cap \gamma$ is nonseparating in γ .

Product discs and annuli detect where a sutured manifold is locally a product. It is therefore not difficult to prove the following lemma.

Lemma 3.2.10 (See [30, Theorem 1.9]). *Let $(M, \gamma) \xrightarrow{S} (M', \gamma')$ be a sutured manifold decomposition. If S is either a product annulus or a product disc, then (M, γ) is a product sutured manifold if and only if (M', γ') is a product sutured manifold.*

Proving that a sutured manifold is not a product is a harder question, but sometime the following lemma can be useful.

Lemma 3.2.11 ([30, Corollary 2.7]). *If the sutured manifold decompositions $(M, \gamma) \xrightarrow{S} (M', \gamma')$ and $(M, \Gamma) \xrightarrow{S} (M'', \gamma'')$ yield both taut sutured manifolds and S is neither a product annulus nor a product disc, then (M, γ) is not a product sutured manifold.*

3.3 From nonfibredness to taut foliations

We introduce some notation. Let K be a genus-one knot in S^3 , and let Y_K be the three-manifold obtained as 0-surgery on K . Let T be a minimal genus Seifert surface for K and let \hat{T} be the torus in Y_K obtained by capping T off with a meridian disc of the solid torus of the surgery. We denote $M_{\hat{T}} = Y_K \setminus \hat{T}$ and $\partial M_{\hat{T}} = \hat{T}_+ \cup \hat{T}_-$, where \hat{T}_+ is given the orientation induced by the orientation of $M_{\hat{T}}$ by the outward normal convention, and \hat{T}_- is given the opposite one. By [32, Corollary 8.3] $M_{\hat{T}}$ is irreducible and moreover, by [32, Corollary 8.19], it is diffeomorphic to the product $\hat{T} \times [0, 1]$ if and only if K is fibred.

By a folklore result² the symmetrised Alexander polynomial Δ_K is monic and has degree one if and only if the maps $(\iota_{\pm})_* : H_1(\hat{T}_{\pm}; \mathbb{Z}) \rightarrow H_1(M_{\hat{T}})$ induced by the inclusions $\iota_{\pm} : \hat{T}_{\pm} \hookrightarrow M_{\hat{T}}$ are isomorphisms. We say in this case that $M_{\hat{T}}$ is a *homology product*. This fact is not limited to genus one knots; see [39, Lemma 4.10] for a proof.

²Thanks to Stefan Friedl for the communications

Assume that Δ_K is monic and has degree one, so that $M_{\widehat{T}}$ is a homology product. We take oriented simple closed curves α_{\pm} and β_{\pm} in \widehat{T}_{\pm} such that both $\alpha_+ \cup -\alpha_-$ and $\beta_+ \cup -\beta_-$ bound a surface in $M_{\widehat{T}}$. We assume also that α_+ and β_+ , as well as α_- and β_- , intersect transversally in a unique point.

Let μ be a properly embedded arc in $M_{\widehat{T}}$ with one endpoint on \widehat{T}_- and one on \widehat{T}_+ which closes to the core of the surgery torus in Y_K . We orient μ from \widehat{T}_- to \widehat{T}_+ . Denote by $\mathcal{S}_n^+(\alpha)$ the set of the connected and properly embedded surfaces in M which are bounded by $\alpha_+ \cup -\alpha_-$ and which intersect the arc μ transversally in exactly n positive points and in no negative points, and by $\mathcal{S}_n^-(\alpha)$ the set of the surfaces with the same property bounded by $-\alpha_+ \cup \alpha_-$. Let $\mathcal{S}_n^+(\beta)$ and $\mathcal{S}_n^-(\beta)$ be the same for the curves β_+ and β_- . Let $\kappa_n^+(\alpha)$ be the minimal genus of the surfaces in $\mathcal{S}_n^+(\alpha)$ and define $\kappa_n^-(\alpha)$, $\kappa_n^+(\beta)$, and $\kappa_n^-(\beta)$ in analogous ways.

Lemma 3.3.1. *The sequences $\{\kappa_n^+(\alpha)\}$, $\{\kappa_n^-(\alpha)\}$, $\{\kappa_n^+(\beta)\}$, and $\{\kappa_n^-(\beta)\}$ are non increasing. If $M_{\widehat{T}}$ is not homeomorphic to a product, then for all $n \geq 0$ we have either $\kappa_n^+(\alpha) \neq 0$ and $\kappa_n^-(\alpha) \neq 0$, or $\kappa_n^+(\beta) \neq 0$ and $\kappa_n^-(\beta) \neq 0$.*

Proof. The sequences are nonincreasing because \widehat{T}_+ and \widehat{T}_- are tori, and therefore cut-and-paste surgery of a surface in $\mathcal{S}_n^{\pm}(\alpha)$ or $\mathcal{S}_n^{\pm}(\beta)$ with \widehat{T}_{\pm} does not increase the genus.

Assume that there are annuli $A_{\alpha} \in \mathcal{S}_n^+(\alpha) \cup \mathcal{S}_n^-(\alpha)$ and $A_{\beta} \in \mathcal{S}_n^+(\beta) \cup \mathcal{S}_n^-(\beta)$. By a standard argument in low-dimensional topology we can assume that, after an isotopy, $A_{\alpha} \cap A_{\beta}$ consists only of a segment connecting $\alpha_+ \cap \beta_+$ with $\alpha_- \cap \beta_-$. The boundary of $M \setminus (A_{\alpha} \cup A_{\beta})$ is homeomorphic to S^2 , and therefore $M \setminus (A_{\alpha} \cup A_{\beta})$ is homeomorphic to $T_+ \setminus (\alpha_+ \cup \beta_+) \times [0, 1] \cong D^3$ because M is irreducible. This proves that M is homeomorphic to $T_+ \times [0, 1]$. \square

Now fix a genus one fibred knot K_0 and denote by T_0 a genus one Seifert surface of K_0 , which is necessarily the closure of a fibre of the fibration on $S^3 \setminus K_0$. We form the connected sum $K \# K_0$, which has a Seifert surface Σ obtained by a boundary connected sum between T and T_0 . Let $Y_{K \# K_0}$ be the three-manifold obtained as 0-surgery on $K \# K_0$ and $\widehat{\Sigma}$ the closed surface obtained by capping Σ off with a meridian disc of the solid torus of the surgery. We denote $M_{\widehat{\Sigma}} = Y_{K \# K_0} \setminus \widehat{\Sigma}$ and $\partial M_{\widehat{\Sigma}} = \widehat{\Sigma}_+ \sqcup \widehat{\Sigma}_-$.

Proposition 3.3.2. *Let K be a genus one knot in S^3 such that Δ_K is monic of degree one. If K is not fibred, then there exist two smooth taut foliations \mathcal{F}_+ and \mathcal{F}_- on $Y_{K \# K_0}$ such that*

1. $\widehat{\Sigma}$ is a leaf for both,
2. both are product foliations in a neighbourhood of $\widehat{\Sigma}$, and

3. there exists a properly embedded surface $R \subset M_{\widehat{\Sigma}}$ such that $\partial R \cap \widehat{\Sigma}_+$ and $\partial R \cap \widehat{\Sigma}_-$ are both connected and $e(\mathcal{F}_+, R) \neq e(\mathcal{F}_-, R)$.

The rest of the section is the proof of the proposition. From now on, we assume that K is a knot in S^3 of genus one which is not fibred and whose symmetrised Alexander polynomial is monic of degree one. By Lemma 3.3.1 (and possibly after renaming the curves α and β) $\kappa_n^\pm(\alpha) \neq 0$ for any $n \geq 0$, and moreover there is an integer m such that $\kappa_{m+i}^\pm(\alpha) = \kappa_m^\pm(\alpha)$ for all $i \geq 0$. We fix closed surfaces $S_m^+ \in \mathcal{S}_m^+(\alpha)$ and $S_m^- \in \mathcal{S}_m^-(\alpha)$ such that S_m^+ has genus $\kappa_m^+(\alpha)$ and S_m^- has genus $\kappa_m^-(\alpha)$.

Let ν denote a tubular neighbourhood. then $M_{\widehat{T}} \setminus \nu(\mu)$ is homeomorphic to $S^3 \setminus \nu(T)$. We can divide $\partial(M_{\widehat{T}} \setminus \nu(\mu))$ in two pieces: $\partial_h(M_{\widehat{T}} \setminus \nu(\mu)) = \partial M_{\widehat{T}} \setminus \nu(\mu)$ called the *horizontal boundary*, and $\partial_v(M_{\widehat{T}} \setminus \nu(\mu)) = \partial\nu(\mu) \setminus \partial M_{\widehat{T}}$ called the *vertical boundary*. We denote by μ_0 a similar segment in $M_{\widehat{T}_0}$. It is easy to see (e.g. [39, Lemma 4.13]) that $Y_{K\#K_0}$ is diffeomorphic to the three manifold obtained by splicing the complements of K and K_0 so that meridian is matched with meridian and longitude is matched to longitude. Moreover $\widehat{\Sigma} = T \cup T_0$ glued along the boundary. Thus we can decompose $M_{\widehat{\Sigma}}$ as $(M_{\widehat{T}} \setminus \nu(\mu)) \cup (M_{\widehat{T}_0} \setminus \nu(\mu_0))$ glued together along their vertical boundary.

From S_m^+ and S_m^- we can construct surfaces \widehat{S}_+ and \widehat{S}_- in $M_{\widehat{\Sigma}}$ by gluing a copy of T_0 to each one of the m components of $S_m^\pm \cap \partial_v(M_{\widehat{T}} \setminus \nu(\mu))$. From an abstract point of view \widehat{S}_+ and \widehat{S}_- are obtained by performing a connected sum with a copy of \widehat{T}_0 at each of the m intersection points between S_m^+ or S_m^- and μ , and therefore $g(\widehat{S}_\pm) = \kappa_m^\pm(\alpha) + m$.

Consider the taut sutured manifold $(M_{\widehat{\Sigma}}, \gamma)$ where $\gamma = \emptyset$. We claim that

$$(M_{\widehat{\Sigma}}, \gamma) \overset{\widehat{S}_+}{\rightsquigarrow} (M_{\widehat{\Sigma}} \setminus \widehat{S}_+, \gamma_+)$$

$$(M_{\widehat{\Sigma}}, \gamma) \overset{\widehat{S}_-}{\rightsquigarrow} (M_{\widehat{\Sigma}} \setminus \widehat{S}_-, \gamma_-)$$

are taut sutured manifold decompositions. By Remark 3.2.8, to prove this it is enough to prove to proving that the surfaces $\widehat{S}_+ + \widehat{\Sigma}_+$, $\widehat{S}_+ + \widehat{\Sigma}_-$, $\widehat{S}_- + \widehat{\Sigma}_+$, and $\widehat{S}_- + \widehat{\Sigma}_-$ obtained by cut-and-paste surgery between \widehat{S}_\pm and $\widehat{\Sigma}_\pm$ are norm minimising in $H_2(M_{\widehat{\Sigma}}, \alpha_+ \cup \alpha_-)$.

We recall that \widehat{T}_+ and $\widehat{\Sigma}_+$ are oriented by the outward normal convention, while \widehat{T}_- and $\widehat{\Sigma}_-$ are oriented by the inward normal convention. For this reason $\mu \cap \widehat{T}_+$ and $\mu \cap \widehat{T}_-$ consist both of one single positive point.

We will consider only $\widehat{S}_+ + \widehat{\Sigma}_+$, the remaining cases being similar due to the above consideration. Let $\widetilde{S} \subset M_{\widehat{\Sigma}}$ be a surface with $\partial\widetilde{S} = \alpha_- \cup \alpha_+$ in the same relative homology class as $\widehat{S}_+ + \widehat{\Sigma}_+$ and norm minimising in $H_2(M_{\widehat{\Sigma}}, \alpha_- \cup \alpha_+)$. We can see \widetilde{S} as the union of two (possibly disconnected) properly embedded

surfaces with boundary $S \subset M_{\widehat{T}} \setminus \nu(\mu)$ and $S_0 \subset M_{\widehat{T}_0} \setminus \nu(\mu_0)$; then $\chi(\widetilde{S}) = \chi(S) + \chi(S_0)$. We can easily modify \widetilde{S} without increasing its genus so that it intersects $\partial_v(M_{\widehat{T}} \setminus \nu(\mu))$ and $\partial_v(M_{\widehat{T}_0} \setminus \nu(\mu_0))$ in homotopically non trivial curves. The number of connected components of $\partial S_0 = \partial S \cap \partial_v(M_{\widehat{T}} \setminus \nu(\mu))$ counted with sign is $m + 1$.

Since $\chi(S) + \chi(S_0) = \chi(\widetilde{S}) = 2 - 2g(\widetilde{S})$, and \widetilde{S} is norm minimising, both S and S_0 minimise the norm in their relative homology classes. $M_{\widehat{T}_0} \setminus \nu(\mu_0)$ is a product $T_0 \times [0, 1]$, and therefore $\chi(S_0)$ is equal to the negative of the number of components of ∂S_0 counted with sign, i.e. $\chi(S_0) = -(m + 1)$. We can modify S_0 without changing $\chi(S_0)$ so that it consists of some boundary parallel annuli and $m + 1$ parallel copies of T_0 , and then we push the boundary parallel annuli into $M_{\widehat{T}} \setminus \nu(\mu)$, so that we have a new surface $S' \subset M_{\widehat{T}} \setminus \nu(\mu)$ whose intersection with $\partial_v(M_{\widehat{T}} \setminus \nu(\mu))$ consists of exactly $m + 1$ positively oriented non trivial closed curves. If we glue discs to these curves we obtain a surface $S_{m+1}^+ \in \mathcal{S}_{m+1}^+(\alpha)$ such that

$$g(\widetilde{S}) = g(S_{m+1}^+ \# \widehat{T}_0^{\#(m+1)}) = \kappa_{m+1}^+(\alpha) + m + 1.$$

Since

$$g(\widehat{S}_+ + \widehat{\Sigma}_+) = g(\widehat{S}_+) + 1 = g(S_m^+ \# \widehat{T}_0^{\#m}) + 1 = g(S_m^+) + m + 1 = \kappa_m^+(\alpha) + m + 1$$

and $\kappa_{m+1}^+(\alpha) = \kappa_m^+(\alpha)$, we conclude that $g(\widehat{S}_+ + \widehat{\Sigma}_+) = g(\widetilde{S})$, which implies that $g(\widehat{S}_+ + \widehat{\Sigma}_+)$ is norm minimising in its relative homology class.

By Proposition 3.2.7 the taut sutured manifold decompositions

$$\begin{aligned} (M_{\widehat{\Sigma}}, \gamma = \emptyset) &\overset{\widehat{\Sigma}_+}{\rightsquigarrow} (M_{\widehat{\Sigma}} \setminus \widehat{S}_+, \gamma_+) \\ (M_{\widehat{\Sigma}}, \gamma = \emptyset) &\overset{\widehat{\Sigma}_-}{\rightsquigarrow} (M_{\widehat{\Sigma}} \setminus \widehat{S}_-, \gamma_-) \end{aligned}$$

provide taut smooth foliations \mathcal{F}_+ and \mathcal{F}_- such that $\widehat{\Sigma}$ is a closed leaf for both so that, in particular,

$$\langle e(\mathcal{F}_+), [\widehat{\Sigma}] \rangle = \langle e(\mathcal{F}_-), [\widehat{\Sigma}] \rangle = \chi(\widehat{\Sigma}) = -2.$$

Moreover $e(\mathcal{F}_+, \widehat{S}_+) = \chi(\widehat{S}_+)$ and $e(\mathcal{F}_-, \widehat{S}_-) = \chi(\widehat{S}_-)$.

Take any surface $R \in \mathcal{S}_0^+(\alpha)$; then $-R \in \mathcal{S}_0^-(\alpha)$, and therefore $[\widehat{S}_+] = [R] + m[\widehat{\Sigma}]$ and $[\widehat{S}_-] = -[R] + m[\widehat{\Sigma}]$ as relative homology classes in $H_2(M_{\widehat{\Sigma}}, \alpha_+ \cup \alpha_-)$. Therefore

$$e(\mathcal{F}_+, \widehat{S}_+) = e(\mathcal{F}_+, R) + m\chi(\widehat{\Sigma}) = e(\mathcal{F}_+, R) - 2m$$

and

$$e(\mathcal{F}_-, \widehat{S}_-) = e(\mathcal{F}_-, -R) + m\chi(\widehat{\Sigma}) = -e(\mathcal{F}_-, R) - 2m.$$

This implies

$$e(\mathcal{F}_+, R) = \chi(\widehat{S}_+) + 2m = \chi(S_m^+) = -2\kappa_m^+(\alpha) \quad (3.2)$$

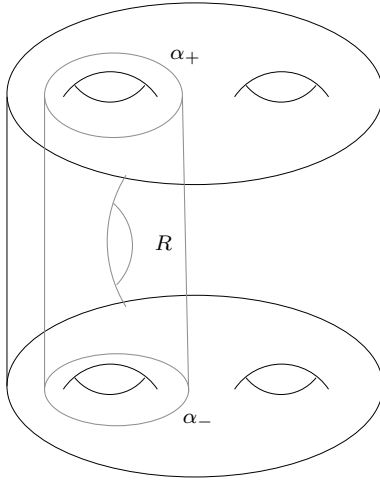

Figure 3.2: A somewhat misleading picture of $R \subset Y \setminus \widehat{\Sigma}$

and

$$e(\mathcal{F}_-, R) = -\chi(\widehat{S}_-) - 2m = -\chi(S_m^-) = 2\kappa_m^-(\alpha). \quad (3.3)$$

Recall that $\chi(S_m^\pm) = -2\kappa_m^\pm(\alpha)$ because S_m^+ and S_m^- have 2 boundary components each. Equations 3.2 and 3.3 imply that $e(\mathcal{F}_+, R) \neq e(\mathcal{F}_-, R)$ because $\kappa_m^\pm(\alpha) > 0$.

3.4 From taut foliations to knot Floer homology

In this section we prove that the foliations \mathcal{F}_+ and \mathcal{F}_- constructed in Proposition 3.3.2 produce distinct elements in $\widehat{HFK}(K, -1)$. A more general intermediate statement is the following.

Proposition 3.4.1. *Let Y be a closed three-manifold with $H_1(Y; \mathbb{Z}) = \mathbb{Z}$. If there exist two taut foliations \mathcal{F}_+ and \mathcal{F}_- on Y such that*

1. \mathcal{F}_+ and \mathcal{F}_- have a common leaf $\widehat{\Sigma}$ of genus $g > 1$,
2. both are product foliations in a neighbourhood of $\widehat{\Sigma}$, and
3. there exists a properly embedded surface $R \subset M_{\widehat{\Sigma}} = Y \setminus \widehat{\Sigma}$ such that
 - (a) $\partial R = \alpha_+ \sqcup \alpha_-$ where $\alpha_+ \subset \Sigma_+$ and $\alpha_- \subset \Sigma_-$ are nonseparating simple closed curves ($\partial M_{\widehat{\Sigma}} = \widehat{\Sigma}_+ \sqcup \widehat{\Sigma}_-$), and
 - (b) $e(\mathcal{F}_+, R) \neq e(\mathcal{F}_-, R)$,

then $\dim HF^+(Y, 1-g) > 1$, where $HF^+(Y, 1-g) = \bigoplus_{\langle c_1(\mathfrak{t}), [\widehat{\Sigma}] \rangle = 2-2g} HF^+(Y, \mathfrak{t})$.

Before sketching the proof of this proposition, we show how it implies Theorem 3.1.3.

Proof of Theorem 3.1.3. Let K be a genus one knot in S^3 which is not fibred. If Δ_K is not monic of degree one, then $\widehat{HFK}(K, -1) \neq \mathbb{F}$ by Equation (3.1). Then, from now on, we assume that Δ_K is monic and has degree one. We choose a genus one fibred knot K_0 . We recall that $\widehat{HFK}(K, d) = \widehat{HFK}(K_0, d) = 0$ for $d < -1$ and $\widehat{HFK}(K_0, -1) \cong \mathbb{F}$; thus by the Künneth formula for knot Floer homology [91, Corollary 7.2] we conclude that $\widehat{HFK}(K \# K_0, -2) \cong \widehat{HFK}(K, -1)$. Let $Y_{K \# K_0}$ be the three-manifold obtained by performing 0-surgery on $K \# K_0$: by [91, Corollary 4.5] and the symmetry of knot Floer homology [91, Equation (3)], $\widehat{HFK}(K, -1) \cong HF^+(Y_{K \# K_0}, -2)$. Since K is not fibred and Δ_K is monic of degree one, Propositions 3.3.2 and 3.4.1 provide two distinct nonzero elements in $HF^+(Y_{K \# K_0}, -2)$. This proves Theorem 3.1.3. \square

In the rest of this section we prove Proposition 3.4.1. The strategy of the proof is to perturb \mathcal{F}_+ and \mathcal{F}_- to contact structures ξ_+ and ξ_- on $-Y$ so that $c^+(\xi_{\pm}) \in HF^+(Y, 1-g)$, and then to construct a new three-manifold Y_ϕ together with a Weinstein cobordism W from $-Y_\phi$ to $-Y$ such that $F_W^+(c^+(\xi_+))$ and $F_W^+(c^+(\xi_-))$ are linearly independent in $HF^+(Y_\phi)$. Now we see the construction in more detail.

We choose a diffeomorphism $\phi: \widehat{\Sigma}_+ \rightarrow \widehat{\Sigma}_-$ such that $\phi(\alpha_+) = \alpha_-$, which exists because α_+ and α_- are non separating, and form a new three-manifold Y_ϕ from $M_{\widehat{\Sigma}}$ by gluing $\widehat{\Sigma}_+$ to $\widehat{\Sigma}_-$ using ϕ . We decompose ϕ as a product $\phi = \prod \tau_{c_1} \dots \tau_{c_k}$ where each τ_{c_i} is a positive Dehn twist around a non-separating curve $c_i \subset \widehat{\Sigma}$.

We identify a tubular neighbourhood of $\widehat{\Sigma}$ on which \mathcal{F}_+ and \mathcal{F}_- are product foliations with $\widehat{\Sigma} \times [-1, 1]$ and choose distinct points t_1, \dots, t_k in $(-1, 1)$. Then we define the link

$$C = c_1 \times \{t_1\} \cup \dots \cup c_k \times \{t_k\} \subset Y.$$

The surface $\widehat{\Sigma} \times \{t_i\}$ induces a framing on $c_i \times \{t_i\}$, and one can see that Y_ϕ is obtained by (-1) -surgery on the link C where the surgery coefficient of each component is computed with respect to that framing. Equivalently, $-Y_\phi$ is obtained by $(+1)$ -surgery on the same link C seen as a link in $-Y$.

Using [39, Lemma 3.5], which is a slightly more controlled version of Eliashberg and Thurston's perturbation from [24], we can perturb \mathcal{F}_+ and \mathcal{F}_- to contact structures ξ_+ and ξ_- on $-Y$ such that α_{\pm} and C are Legendrian for both ξ_+ and ξ_- and the contact framing coincides with the framing induced by $\widehat{\Sigma}$. By the proof of [90, Theorem 1.2] we have $c^+(\xi_{\pm}) \neq 0$. Invariant of contact structures coming from the perturbation of taut foliations in general are nontrivial only with twisted coefficients; to have nonvanishing with untwisted coefficients here

it is important that $H_2(Y)$ is generated by the class of $\widehat{\Sigma}$ and $\langle c_1(\xi_{\pm}), [\widehat{\Sigma}] \rangle = 2 - 2g < 0$.

We denote by ξ'_{\pm} the contact structures on $-Y_{\phi}$ obtained by contact (+1)-surgery along C . Contact (+1)-surgery is the inverse operation of Legendrian surgery, and therefore there are Weinstein cobordisms from $(-Y_{\phi}, \xi_{\pm})$ to $(-Y, \xi_{\pm})$ with the same underlying smooth cobordism W . The map

$$F_{\overline{W}}^+ : HF^+(Y, g-1) \rightarrow HF^+(Y_{\phi}, g-1) \quad (3.4)$$

is an isomorphism by an argument which is similar to the proof of [94, Lemma 5.4]. First, by the composition formula [97, Theorem 3.4] it is enough to prove that the map in Equation (3.4) is an isomorphism when W is obtained by a single handle attachment. In this case Y_{ϕ} is obtained from Y by (-1)-surgery along a curve c , and therefore $F_{\overline{W}}^+$ fits into the exact triangle of [92, Theorem 9.12], which in the case at hand becomes

$$\begin{array}{ccc} HF^+(Y, g-1) & \xrightarrow{F_{\overline{W}}^+} & HF^+(Y_{\phi}, g-1) \\ & \searrow & \swarrow \\ & HF^+(Y_0, g-1) & \end{array}$$

where Y_0 is obtained by 0-surgery on c .

Since c bounds a disc in Y_0 , there is a surface $\Sigma' \subset Y_0$ with $\chi(\Sigma') > \chi(\widehat{\Sigma}) = 2g - 2$. Such surface violates the adjunction inequality [92, Theorem 7.1], and therefore $HF^+(Y_0, g-1) = 0$. This implies that

$$F_{\overline{W}}^+ : HF^+(Y, g-1) \rightarrow HF^+(Y_{\phi}, g-1)$$

is an isomorphism, and therefore $c(\xi'_{\pm}) = F_{\overline{W}}^+(c^+(\xi_{\pm})) \neq 0$.

In Y_{ϕ} the surface $R \subset M_{\overline{\Sigma}}$ closes up to a surface \overline{R} . Moreover, it is easy to verify that

$$\langle c_1(\xi'_{\pm}), [\overline{R}] \rangle = e(\mathcal{F}_{\pm}, R)$$

and therefore $c^+(\xi'_+)$ and $c^+(\xi'_-)$ belong to different Spin^c structures because $e(\mathcal{F}_+, R) \neq e(\mathcal{F}_-, R)$. This proves that $c^+(\xi_+) \neq c^+(\xi_-)$ because $F_{\overline{W}}^+$ is injective.

Chapter 4

Heegaard Floer homology and embedded contact homology

4.1 Introduction

In the search for gluing formulas for gauge theoretic invariants of four-manifolds (Donaldson’s invariants and Seiberg-Witten invariants) it was soon realised that the object which should be associated to a three-manifold is a Floer homology. The first to be constructed was *instanton Floer homology* in [27] by Floer himself, although only for integer homology spheres. On the other hand, the development of a Seiberg-Witten Floer homology languished for several years, until Kronheimer and Mrowka defined *monopole Floer homology* in [73].

In the meantime the deep connection between gauge theory and symplectic geometry became clear. For example, Atiyah proposed a conjectural reinterpretation of instanton Floer homology as a Lagrangian intersection Floer homology, now known as the “Atiyah-Floer conjecture”, in [1] and Taubes proved in [103] that the Seiberg-Witten invariants on a symplectic four-manifold are equivalent to a count of J -holomorphic curves which, in most cases, are embedded. This result is usually called “SW=Gr”.

Motivated by the Atiyah-Floer conjecture, Ozsváth and Szabó defined *Heegaard Floer homology* in [93, 92] as a symplectic counterpart of Monopole Floer homology. Instead of the original definition, in this article we will use an equivalent one given by Lipshitz in [80]. The starting point of the construction of Heegaard Floer homology is a *pointed Heegaard diagram* $(\Sigma, \boldsymbol{\alpha}, \boldsymbol{\beta}, z)$ which describes a three-manifold M . Here Σ is a genus $g > 0$ Heegaard surface associated to

some self-indexing Morse function with a unique maximum and a unique minimum, α is the collection of the attaching circles for the index one critical points, β is the collection of the attaching circles for the index two critical points, and z is a base point in the complement of α and β . The Heegaard Floer complexes are generated by g -tuples of intersection points between the α -curves and the β -curves and the differential counts certain J -holomorphic curves in $\mathbb{R} \times [0, 1] \times \Sigma$ with boundary on $\mathbb{R} \times \{0\} \times \beta$ and $\mathbb{R} \times \{1\} \times \alpha$. We refer to Section 4.3 for an overview of Heegaard Floer homology in its cylindrical reformulation.

Hutchings, later in collaboration with Taubes, defined *embedded contact homology* in [60, 63, 64] motivated by SW=Gr and by Eliashberg, Givental and Hofer's symplectic field theory [23]. The starting point for embedded contact homology is a contact form α on M . A contact form determines the *Reeb vector field* R by

$$\iota_R d\alpha = 0 \quad \text{and} \quad \alpha(R) = 1.$$

The embedded contact homology complex is generated by finite sets of simple Reeb orbits with finite multiplicities (called orbit sets) and its differential counts certain J -holomorphic curves in the symplectisation $(\mathbb{R} \times M, d(e^s \alpha))$. We refer to Section 4.4 for an overview of embedded contact homology.

Thus by the end of the last decade we had three Floer homology theories for three-manifolds, each with its strengths and weaknesses, which were expected to be isomorphic. The relative advantage of monopole Floer homology is its link with geometry, that of embedded contact homology is its link with Reeb dynamics and that of Heegaard Floer homology is that it needs less sophisticated analytical tools than the previous two, which makes it relatively computable and easier to develop. On the other hand, the relation of these three theories with instanton Floer homology is still to be clarified.

While Heegaard Floer homology and embedded contact homology were defined with the purpose of being isomorphic to monopole Floer homology according to some big picture, the actual proofs of the isomorphisms, which appeared in the last ten years, span several hundred pages of very technical arguments. The isomorphism between monopole Floer homology and embedded contact homology is due to Taubes and appeared in [104, 105, 106, 107, 108]. The isomorphism between monopole Floer homology and Heegaard Floer homology is due to Kutluhan, Lee and Taubes and appeared in [74, 75, 76, 77, 78]. The isomorphism between Heegaard Floer homology and embedded contact homology, which appeared in [12, 14, 15, 13], is the topic of this chapter.

These isomorphisms have already had various applications. The most striking ones are the proofs, for contact three manifolds, of the Weinstein conjecture by Taubes [109] and of the Arnold's chord conjecture by Hutchings and Taubes [66, 67] based on the isomorphism between monopole Floer homology and embedded contact homology proved by Taubes.

The picture, however, is not yet complete for several reasons. First of all, the definitions of the isomorphisms require some choices, but it is not clear at what

extent the result depends on them. Second, we do not know if composing two of the isomorphisms we obtain the third one.¹ Finally, monopole Floer homology and Heegaard Floer homology are “almost” 3 + 1 topological quantum field theories, but it is not known if the isomorphisms commute with maps induced by cobordisms.

The isomorphism between Heegaard Floer homology and embedded contact homology is expressed in a more precise way by the following theorem.

Theorem 4.1.1. *Let M be a closed three manifold and ξ a contact structure on M . Then there are isomorphisms*

$$\begin{aligned}\widehat{\Phi}_* &: \widehat{HF}(-M) \rightarrow \widehat{ECH}(M), \\ \Phi_*^+ &: HF^+(-M) \rightarrow ECH(M)\end{aligned}$$

such that the diagram

$$\begin{array}{ccccccc} \dots & \longrightarrow & \widehat{HF}(-M) & \longrightarrow & HF^+(-M) & \xrightarrow{U} & HF^+(-M) \longrightarrow \dots \\ & & \widehat{\Phi}_* \downarrow & & \Phi_*^+ \downarrow & & \Phi_*^+ \downarrow \\ \dots & \longrightarrow & \widehat{ECH}(M) & \longrightarrow & ECH(M) & \xrightarrow{U} & ECH(M) \longrightarrow \dots \end{array} \quad (4.1)$$

commutes. Moreover the isomorphisms map the contact class to the contact class and match the splitting according to $Spin^c$ structures on the Heegaard Floer side to the splitting according to first homology classes on the embedded contact homology side.²

Vinicius Ramos in [100] proved that $\widehat{\Phi}_*$ and Φ_*^+ respect also the grading by homotopy classes of plane fields which exists in both theories.

A natural setting for relating Heegaard Floer homology and embedded contact homology is that of *open book decompositions* (see Definition 4.3.6) because an open book decomposition determines both a Heegaard splitting and a contact structure. The Heegaard splitting is obtained by taking as Heegaard surface the union of two opposite pages. The contact structure is provided by the Thurston-Winkelnkemper construction [110].

Fix an open book decomposition (S, \mathfrak{h}) for M where S has genus $g > 0$. The first step in the definition of the isomorphisms to adapt the definitions of $\widehat{HF}(-M)$ and $\widehat{ECH}(M)$ to the open book decomposition (S, \mathfrak{h}) . For Heegaard Floer homology this is achieved by pushing all interesting intersection points between the α - and β -curves to one side of the Heegaard surface obtained from (S, \mathfrak{h}) ; see Subsection 4.3.3.

¹This question will make sense only after answering the previous one.

²For simplicity we will not talk about $Spin^c$ structures.

For embedded contact homology, this is achieved in [12] and reviewed in Subsections 4.4.3 and 4.4.4. There we introduce the group $\widehat{ECH}(N, \partial N)$ for the mapping torus N of (S, \hat{h}) and prove that $\widehat{ECH}(M) \cong \widehat{ECH}(N, \partial N)$. This group is defined as a direct limit

$$\widehat{ECH}(N, \partial N) = \varinjlim ECH_i(N),$$

where $ECH_i(N)$ is the homology of a chain complex generated by the orbit sets in N which intersect a fibre i times and the direct limit is taken with respect to maps $ECH_i(N) \rightarrow ECH_{j+1}(N)$ defined by increasing the multiplicity of an elliptic orbit in ∂N . This elliptic orbit can be regarded intuitively as a receptacle for the J -holomorphic curves in $\mathbb{R} \times M$ which intersect the cylinder over the binding.

Chain maps between Floer complexes are often defined by counting holomorphic curves in some symplectic cobordism.

Convention 4.1.2. *In this chapter we will use the convention that symplectic cobordisms go from the positive end to the negative end. This is the opposite of the convention we used in the previous chapters.*

Here, we use the open book (S, \hat{h}) to build a symplectic cobordism W_+ from $[0, 1] \times S$ to N and a symplectic cobordism X_+ from $[0, 1] \times \Sigma$ to M . Counting holomorphic curves in W_+ and X_+ with suitable Lagrangian boundary conditions gives maps $\Phi_*: \widehat{HF}(-M) \rightarrow ECH_{2g}(N)$ and $\Phi_*^+: HF^+(-M) \rightarrow ECH(M)$. After composing Φ_* with the natural map $ECH_{2g}(N) \rightarrow \widehat{ECH}(N, \partial N)$, we obtain the map $\widehat{\Phi}_*$. The maps Φ_* and $\widehat{\Phi}_*$ are defined in [14] (with a slightly different notation), while Φ_*^+ is defined in [13]. Both are reviewed in Section 4.5. Strictly speaking, in the construction of Φ , we replace the embedded Floer homology groups of N with isomorphic periodic Floer homology groups; see Subsection 4.4.6.

In [14] we also define a map $\Psi_*: ECH_{2g}(N) \rightarrow \widehat{HF}(-M)$ by counting holomorphic curves in a symplectic cobordism \overline{W}_- passing through a base point. The cobordism \overline{W}_+ is defined as a compactification of W_+ turned upside-down. The Lagrangian boundary condition on \overline{W}_- is singular, and this leads to many more potential degenerations of holomorphic curves. For this reason, the proof that Ψ_* is defined is longer and more difficult than the proof that Φ_* is defined. The construction of Ψ_* is reviewed in Section 4.6.

Then, in [15] we prove that Φ_* and Ψ_* are inverses of each other by composing the two cobordisms and degenerating them in a different way. The proof that $\Phi_* \circ \Psi_*$ and $\Psi_* \circ \Phi_*$ are the identity is thus reduced to a computation of some relative Gromov-Taubes invariants. This step is briefly described in Section 4.7.

Finally we prove that the natural map $ECH_{2g}(N) \rightarrow \widehat{ECH}(N, \partial N)$ is an isomorphism by an argument based on stabilising the open book decomposition.

This last step is described in Section 4.8. This finishes the proof that $\widehat{\Phi}_*$ is an isomorphism. A simple algebraic argument based on the commutativity of the diagram (4.1) and the properties of the map U in both theories shows that Φ_*^+ is also an isomorphism.

Convention 4.1.3. *Throughout this chapter we will follow the convention that all three-manifolds are connected, oriented and compact. If N is a three-manifold with boundary, we will denote $\text{int}(N) = N \setminus \partial N$.*

4.2 Moduli spaces of J -holomorphic curves

In this section we review some generalities about moduli spaces of holomorphic curves with the goal of fixing notations and conventions. The reader should keep in mind that we are not trying to give a one-size-fits-all definition of the various moduli space we will use: each one will be defined in due course; here we introduce the terminology that we will use in their definitions.

Let \mathcal{Y} be a compact, oriented three-manifold. A *stable Hamiltonian structure* on \mathcal{Y} is a pair (α, ω) where α is a 1-form and ω is a closed 2-form which satisfy $\alpha \wedge \omega > 0$ and $\ker d\alpha \subset \ker \omega$. Stable Hamiltonian structures in this article will satisfy also one of the following conditions:

- (i) $d\alpha = \omega$, or
- (ii) $d\alpha = 0$.

Clearly when (i) is satisfied α is a contact form on \mathcal{Y} . Fibrations over S^1 are the main source of stable Hamiltonian structures satisfying (ii). In fact, if $\pi: \mathcal{Y} \rightarrow S^1$ is a locally trivial fibration with fibre \mathcal{S} , it is always possible to find a representative of the monodromy $\phi: \mathcal{S} \rightarrow \mathcal{S}$ preserving an area form ω , and therefore to regard ω as a 2-form on \mathcal{Y} . If dt is a length form on S^1 and we define $\alpha = \pi^* dt$, then (α, ω) will be called the stable Hamiltonian structure *induced by the fibration* $\pi: \mathcal{Y} \rightarrow S^1$.

A stable Hamiltonian structure determines a Reeb vector field³ R on \mathcal{Y} , which is the vector field defined by the equations

$$\begin{cases} \alpha(R) = 1, \\ \iota_R \omega = 0. \end{cases}$$

An almost complex structure J on $\mathbb{R} \times \mathcal{Y}$ is *compatible* with the stable Hamiltonian structure (α, ω) , or with the contact form α when (i) is satisfied, if

- J is invariant under translations in the \mathbb{R} direction,

³Called also *Hamiltonian vector field*, especially when α is not a contact form.

- $J(\partial_s) = R$, where s denotes the coordinate on \mathbb{R} ,
- $J(\xi) = \xi$, where $\xi = \ker \alpha$, and
- $\omega(\cdot, J\cdot)$ is an Euclidean metric on ξ .

Let $(\mathcal{X}, \Omega_{\mathcal{X}})$ be a symplectic four-manifold, possibly with boundary and cylindrical ends (in the latter case also called a symplectic cobordism). Positive ends are identified with $(0, +\infty) \times \mathcal{Y}$ and negative ends are identified with $(-\infty, 0) \times \mathcal{Y}$ where \mathcal{Y} is a three manifold which, of course, depends on the end. Each \mathcal{Y} is endowed with a stable Hamiltonian structure and, on each end, $\Omega_{\mathcal{X}} = d(e^s \alpha)$ if the stable Hamiltonian structure on \mathcal{Y} satisfies (i), or $\Omega_{\mathcal{X}} = ds \wedge \alpha + \omega$ if it satisfies (ii). In the boundary of \mathcal{X} there is a Lagrangian submanifold \mathcal{L} . The intersection of \mathcal{L} with an end is a half cylinder over a collection of properly embedded curves in $\partial\mathcal{Y}$ which are tangent to ξ . Those curves are called the boundary at infinity⁴ of \mathcal{L} .

On \mathcal{X} we choose an almost complex structure $J_{\mathcal{X}}$ which is compatible with $\Omega_{\mathcal{X}}$ and with the stable Hamiltonian structures on the ends. In order to have SFT compactness for $J_{\mathcal{X}}$ -holomorphic curves, we assume that $\partial\mathcal{X}$ is union of $J_{\mathcal{X}}$ -holomorphic submanifolds which, by positivity of intersection, form a barrier for $J_{\mathcal{X}}$ -holomorphic curves. Note that, in most cases, \mathcal{X} will be the total space of a symplectic fibration $\mathcal{X} \xrightarrow{\varpi} \mathcal{B}$ over a noncompact surface with boundary and the last condition on $J_{\mathcal{X}}$ is obtained by asking that ϖ should be holomorphic, at least near $\partial\mathcal{X}$. We often require more properties from the almost complex structures, but in the text we will recall only those which are relevant for a first reading.

Definition 4.2.1. A $J_{\mathcal{X}}$ -holomorphic curve⁵ in \mathcal{X} with boundary in \mathcal{L} is a triple (F, j, u) such that (F, j) is a smooth Riemann surface, possibly with boundary and punctures, and $u: F \rightarrow \mathcal{X}$ is a proper map satisfying $du \circ j = J_{\mathcal{X}} \circ du$ and mapping each connected component of ∂F to a distinct connected component⁶ of \mathcal{L} . If F is connected, then (F, j, u) is called *irreducible*. If $F_0 \subset F$ is a connected component, the restriction $(F_0, j|_{F_0}, u|_{F_0})$ will be called an *irreducible component* of (F, j, u) .

When \mathcal{X} is the total space of a symplectic fibration $\varpi: \mathcal{X} \rightarrow \mathcal{B}$ we say that a holomorphic curve (F, j, u) is a *degree d multisection* of \mathcal{X} if $\varpi \circ u: F \rightarrow \mathcal{B}$ is a branched cover of degree d .

We can compactify F to \overline{F} by adding the punctures back. If $p \in \overline{F} \setminus F$ is a puncture, we say that V is a neighbourhood of p (in F) if $V \cup \{p\}$ is a

⁴This term will be used only in this section.

⁵or simply a *holomorphic curve* when the almost complex structure is clear from the context.

⁶At some point we will need to consider a singular Lagrangian submanifold. In that case, we will assume that each connected component of ∂F is sent to a distinct connected component of the smooth part of the Lagrangian submanifold.

neighbourhood of p in \overline{F} . The punctures of F are divided into positive and negative punctures so that u maps a neighbourhood of a positive puncture to a positive end of \mathcal{X} and a neighbourhood of a negative puncture to a negative end. Around each positive puncture we choose coordinates $(s, t) \in (0, +\infty) \times [0, 1]$ for a boundary puncture and $(s, t) \in (0, +\infty) \times S^1$ for an interior puncture. Around negative punctures we choose similar coordinates with $(0, +\infty)$ replaced by $(-\infty, 0)$. If e is either a Reeb orbit in \mathcal{Y} reparametrised so that it has period one, or a Reeb chord connecting two points of the boundary at infinity of \mathcal{L} reparametrised over $[0, 1]$, we say that u is *positively* (resp. *negatively*) *asymptotic* to e if, in the neighbourhood of a positive (resp. negative) puncture, $\lim_{s \rightarrow \pm\infty} u(s, t) = e(t)$ (with positive sign for positive punctures and negative sign for negative punctures). We call an *end* of a holomorphic curve (F, j, u) the restriction of u to a neighbourhood of a puncture which is mapped to an end of \mathcal{X} by u .

Definition 4.2.2. If $\mathcal{X} = \mathbb{R} \times \mathcal{Y}$ and $J_{\mathcal{X}}$ is adapted to the stable Hamiltonian structure on \mathcal{Y} , a $J_{\mathcal{X}}$ -holomorphic curve in \mathcal{X} is either a *trivial cylinder* or *strip* if it parametrises $\mathbb{R} \times e$ where e is, respectively, a closed Reeb orbit or a Reeb chord. In a general symplectic manifold \mathcal{X} we say that an end of a $J_{\mathcal{X}}$ -holomorphic curve is *trivial* if it coincides with a portion of a trivial cylinder or strip.

We say that two holomorphic curves (F, j, u) and (F', j', u') are equivalent, and write $(F, j, u) \sim (F', j', u')$, if there exists an orientation-preserving diffeomorphism $\phi: F \rightarrow F'$ extending smoothly over the punctures such that $\phi_*j = j'$ and $u = u' \circ \phi$. Given a set \mathbf{e} of chords and orbits in the various ends, the moduli space⁷ $\mathcal{M}_{\mathcal{X}}(\mathbf{e})$ is the quotient by the equivalence relation \sim of the space of $J_{\mathcal{X}}$ -holomorphic curves in \mathcal{X} with boundary on \mathcal{L} which are asymptotic to the chords and orbits in \mathbf{e} . In the definition of $\mathcal{M}_{\mathcal{X}}(\mathbf{e})$ the topology of F is *not* fixed, and therefore different element of $\mathcal{M}_{\mathcal{X}}(\mathbf{e})$ can have different genera, number of punctures and number of connected components. Moreover, multiple orbits are treated in the embedded contact homology way, which means that only their total multiplicity in \mathbf{e} counts. For example, if \mathbf{e} contains an orbit γ with multiplicity two, then holomorphic curves⁸ in $\mathcal{M}_{\mathcal{X}}(\mathbf{e})$ can have either one end at a double cover of γ or two ends at γ . See [60] or Subsection 4.4.1 for more details.

If $\mathcal{X} = \mathbb{R} \times \mathcal{Y}$, the almost complex structure $J_{\mathcal{X}}$ is compatible with the stable Hamiltonian structure on \mathcal{Y} and, in case \mathcal{Y} has boundary, the Lagrangian boundary condition \mathcal{L} is \mathbb{R} -invariant, then translations in the \mathbb{R} direction act on $\mathcal{M}_{\mathcal{X}}(\mathbf{e})$. This situation will be called the *cylindrical setting*.⁹ We will denote the quotient of $\mathcal{M}_{\mathcal{X}}(\mathbf{e})$ by this action by $\widehat{\mathcal{M}}_{\mathcal{X}}(\mathbf{e})$.

⁷In the next sections we will distinguish chords and orbits belonging to different ends of \mathcal{X} . Here, for simplicity, we don't.

⁸We will always call the elements of the moduli spaces "holomorphic curves" even if, strictly speaking, they are equivalence classes of holomorphic curves

⁹This terminology will be used only in this section.

Let $\mathcal{T}(F)$ be the Teichmüller space of complex structures of F and $\text{Aut}(F, j)$ the group of automorphisms of the Riemann surface (F, j) . To a $J_{\mathcal{X}}$ -holomorphic curve (F, j, u) we associate a formal deformation complex

$$0 \rightarrow T_{id} \text{Aut}(F, j) \xrightarrow{\mathfrak{L}} T_{[j]} \mathcal{T}(F) \oplus \Omega^0(F; u^* T\mathcal{X}) \xrightarrow{D_{j,u}} \Omega^{0,1}(S; u^* T\mathcal{X}) \rightarrow 0$$

where $D_{j,u}$ is the formal linearised Cauchy-Riemann operator where j is also considered as a variable, and \mathfrak{L} is the formal linearisation of the action of $\text{Aut}(F, j)$. If the ends of u are nondegenerate (possibly in the Morse-Bott sense), a suitable Sobolev completion (with weights) of the formal deformation complex is an elliptic complex. Let \mathcal{H}^i (for $i = 0, 1, 2$) be its homology groups, which are finite dimensional because of the Fredholm property. We define the *Fredholm index* of a $J_{\mathcal{X}}$ -holomorphic curve (F, j, u) as

$$\text{ind}(u) = -\dim \mathcal{H}^0 + \dim \mathcal{H}^1 - \dim \mathcal{H}^2$$

If u is not constant (and it will never be constant in this chapter), then $\mathcal{H}^0 = 0$. We say that (F, j, u) is *regular* if the linearised operator $D_{j,u}$ is surjective in the appropriated Sobolev completion, i.e. if $\mathcal{H}^2 = 0$. If (F, j, u) is nonconstant and regular, then some neighbourhood of it in the moduli spaces $\mathcal{M}_{\mathcal{X}}(\mathbf{e})$ is diffeomorphic to a ball of dimension $\text{ind}(u)$. Moreover, in the cylindrical setting, if $\text{ind}(u) \geq 1$, then some neighbourhood of $[u]$ in $\widehat{\mathcal{M}}_{\mathcal{X}}(\mathbf{e})$ is diffeomorphic to a ball of dimension $\text{ind}(u) - 1$. This is all standard holomorphic curves theory, and the reader can find the details in the many expositions of the topic.

In the chapter we will more often use another index, which is specific to holomorphic curves in four-dimensional symplectic manifolds: the ECH-type index $I(u)$. For its definition we refer to the original articles ([60, 61], where it was first introduced for embedded contact homology and [14, 15, 13] for its extension to the various symplectic cobordisms used in the proof of Theorem 4.1.1). Here we will only state its main properties which will be used in the next sections:

1. *homology invariance*: $I(u)$ depends only on the relative homology class defined by u (after a suitable compactification);
2. *concatenation*: if two holomorphic curves (F_+, j_+, u_+) and (F_-, j_-, u_-) such that the positive ends of u_- match the negative ends of u_+ are glued to a holomorphic curve (F, j, u) along the matching ends, then $I(u) = I(u_-) + I(u_+)$; and
3. *index inequality*: if $\delta(u)$ is an algebraic count of singularities of u as in [87, Appendix E], then

$$\text{ind}(u) + 2\delta(u) \leq I(u). \quad (4.2)$$

Moreover there is equality if u has no end which is asymptotic to a closed Reeb orbit.

The index inequality was first proved by McDuff for closed curves as the adjunction inequality (see [87, Appendix E] for a more modern exposition) and reinterpreted by Taubes as an index inequality (see [103]). For punctured curves it was proved by Hutchings in [60] (see also [61]) in order to define embedded contact homology. The extension to other settings is straightforward and is done in [14].

The index inequality has the following important consequence: if $I(u) < 2$ (and, in some cases, also if $I(u) = 2$) then u is embedded and $I(u) = \text{ind}(u)$. Embeddedness in particular implies somewhere injectivity, and therefore for a generic almost complex structure $J_{\mathcal{X}}$ all holomorphic curves of low ECH-type index are regular by standard techniques; see in [87, Section 3.2]. A similar result holds for holomorphic curves of higher index satisfying constraints of sufficiently high codimension. For this reason in [14, 15, 13] we do not need to worry about the regularity issues which trouble many parts of symplectic topology.

Given a property \star (e.g. $I = 0$), we denote the subset of $J_{\mathcal{X}}$ -holomorphic curves in $\mathcal{M}_{\mathcal{X}}(\mathbf{e})$ satisfying \star by $\mathcal{M}_{\mathcal{X}}^{\star}(\mathbf{e})$. This convention will be used throughout this chapter.

For sake of brevity, in the next sections we will always denote a holomorphic curve (F, j, u) simply by u . In view of the embeddedness of the holomorphic curves of low index, we will also often identify a holomorphic curve with its image.

4.3 Heegaard Floer homology

4.3.1 A review of Heegaard Floer homology

In this section we briefly review the Heegaard Floer homology groups associated to a closed three-manifold M . We will work with Lipshitz's "cylindrical reformulation" from [80] instead of with the original definition from [93].

Every closed three-manifold can be encoded by a *pointed Heegaard diagram* $(\Sigma, \boldsymbol{\alpha}, \boldsymbol{\beta}, z)$ associated to a Heegaard decomposition of M . Here Σ is a closed, oriented, connected surface of genus g which divides M into two handlebodies H_{α} and H_{β} , and $\boldsymbol{\alpha} = \{\alpha_1, \dots, \alpha_g\}$ and $\boldsymbol{\beta} = \{\beta_1, \dots, \beta_g\}$ are collections of g pairwise disjoint simple closed curves in Σ which bound discs in H_{α} and H_{β} respectively and are linearly independent in $H_1(\Sigma; \mathbb{Z})$. Finally $z \in \Sigma - \boldsymbol{\alpha} - \boldsymbol{\beta}$ is a base point, which is not needed to describe M , but is a crucial ingredient in the definition of the Heegaard Floer chain complexes.

After fixing an area form ω on Σ , we obtain a stable Hamiltonian structure (dt, ω) on $[0, 1] \times \Sigma$ with Reeb vector field $R = \partial_t$. The submanifolds $L_{\alpha} = \mathbb{R} \times \{1\} \times \boldsymbol{\alpha}$ and $L_{\beta} = \mathbb{R} \times \{0\} \times \boldsymbol{\beta}$ are Lagrangian for the symplectic form

$\Omega_X = ds \wedge dt + \omega$. We choose an almost complex structure on X which is compatible with the stable Hamiltonian structure (dt, ω) and such that the surface $\mathbb{R} \times [0, 1] \times \{z\}$ is holomorphic.

We denote by $\mathcal{S}_{\alpha, \beta}$ the set of unordered g -tuples of intersection points $\mathbf{y} = \{y_1, \dots, y_g\}$ between α - and β -curves for which there is a permutation $\sigma \in \mathfrak{S}_g$ such that $y_i \in \alpha_i \cap \beta_{\sigma(i)}$. Given $\mathbf{y}_+, \mathbf{y}_- \in \mathcal{S}_{\alpha, \beta}$, we consider the moduli space¹⁰ $\mathcal{M}_X(\mathbf{y}_+, \mathbf{y}_-)$ of J -holomorphic curves in X with boundary on $L_\alpha \cup L_\beta$ and asymptotic to chords $[0, 1] \times \mathbf{y}_\pm$ for $s \rightarrow \pm\infty$ (*HF-curves* in the following). Translations in the \mathbb{R} direction act on $\mathcal{M}_X(\mathbf{y}_+, \mathbf{y}_-)$ and we denote the quotient by $\widehat{\mathcal{M}}_X(\mathbf{y}_+, \mathbf{y}_-)$.

To a J -holomorphic curve $u \in \mathcal{M}_X(\mathbf{y}_+, \mathbf{y}_-)$ we associate two topological quantities: an ‘‘intersection number’’ $n_z(u)$, defined as the algebraic intersection of the image of u with $\mathbb{R} \times [0, 1] \times \{z\}$ (see [87, Appendix E] for the intersection number between two J -holomorphic curves), and the ECH-type index¹¹ $I(u)$ ([14, Equation 4.5.4]), which in this context is a reformulation of Lipshitz’s index formula [80, Corollary 4.3] (see also [81]). The index inequality is proved in [14, Theorem 4.5.13]. By positivity of intersection for J -holomorphic curves in dimension four, $n_z(u) \geq 0$. Moreover, by the index inequality, for a generic almost complex structure we have $I(u) \geq 0$ for all HF-curve u .

The chain complex $\widehat{CF}(\Sigma, \alpha, \beta, z)$ is freely generated, as a vector space over the field with two elements \mathbb{F} , by the g -tuples of intersection points in $\mathcal{S}_{\alpha, \beta}$. The differential is defined by

$$\widehat{\partial}\mathbf{y}_+ = \sum_{\mathbf{y}_- \in \mathcal{S}_{\alpha, \beta}} \#\widehat{\mathcal{M}}_X^{I=1, n_z=0}(\mathbf{y}_+, \mathbf{y}_-)\mathbf{y}_-.$$

The chain complex $CF^+(\Sigma, \alpha, \beta, z)$ is freely generated, as a vector space over \mathbb{F} , by the pairs $[\mathbf{y}, i]$ where $\mathbf{y} \in \mathcal{S}_{\alpha, \beta}$ and $i \in \mathbb{N}$. The differential is defined by

$$\partial^+([\mathbf{y}_+, i]) = \sum_{\mathbf{y}_- \in \mathcal{S}_{\alpha, \beta}} \sum_{0 \leq j \leq i} \#\widehat{\mathcal{M}}_X^{I=1, n_z=j}(\mathbf{y}_+, \mathbf{y}_-)[\mathbf{y}_-, i - j].$$

In order to have finite sums we need to assume *weak admissibility*, which can be rephrased by asking that the curves α and β be exact Lagrangian submanifolds for some primitive of ω on $\Sigma \setminus \{z\}$. Weak admissibility can always be achieved up to isotopy of the α - and β -curves and deformation of ω . See [93, Section 4.2.2] or [80, Section 5].

The homologies of $\widehat{CF}(\Sigma, \alpha, \beta, z)$ and $CF^+(\Sigma, \alpha, \beta, z)$ are denoted by $\widehat{HF}(M)$ and $HF^+(M)$ respectively. The fact that they are well defined invariants of three-manifolds up to diffeomorphism was proved in [93] and reproved in [80] for the cylindrical reformulation we are using in this chapter. Naturality is addressed in [71].

¹⁰The same moduli spaces are denoted by $\mathcal{M}_J^X(\mathbf{y}, \mathbf{y}')$ in [14].

¹¹denoted by I_{HF} in [14].

The map $U: CF^+(\Sigma, \alpha, \beta, z) \rightarrow CF^+(\Sigma, \alpha, \beta, z)$ defined as

$$U([\mathbf{y}, i]) = \begin{cases} [\mathbf{y}, i-1] & \text{if } i \geq 1, \\ 0 & \text{if } i = 0 \end{cases}$$

is a chain map. The short exact sequence

$$0 \rightarrow \widehat{CF}(\Sigma, \alpha, \beta, z) \rightarrow CF^+(\Sigma, \alpha, \beta, z) \xrightarrow{U} CF^+(\Sigma, \alpha, \beta, z) \rightarrow 0$$

induces the exact triangle

$$\begin{array}{ccc} HF^+(M) & \xrightarrow{U} & HF^+(M) \\ & \swarrow & \searrow \\ & \widehat{HF}(M) & \end{array} \quad (4.3)$$

in homology. Heegaard Floer homology decomposes as a direct sum of groups indexed by Spin^c structures and the triangle (4.3) holds for every summand. For simplicity we will not discuss this decomposition.

4.3.2 A geometric interpretation of the U -map

This subsection is taken from [13, Section 3]. In [93, 80], the U -map

$$U: CF^+(\Sigma, \alpha, \beta, z) \rightarrow CF^+(\Sigma, \alpha, \beta, z)$$

is defined algebraically as $U([\mathbf{y}, i]) = [\mathbf{y}, i-1]$. The goal of this section is to give a geometric definition of the U -map which is analogous to that of ECH.

Let us fix¹² $\mathbf{z} = (0, \frac{1}{2}, z) \in X = \mathbb{R} \times [0, 1] \times \Sigma$, and let J^\diamond be a generic small perturbation of J supported near \mathbf{z} such that $\mathbb{R} \times [0, 1] \times \{z\}$ remains holomorphic. This perturbation is needed so that J^\diamond -holomorphic curves do not have a closed irreducible component passing through \mathbf{z} .

Given $\mathbf{y}_+, \mathbf{y}_- \in \mathcal{S}_{\alpha, \beta}$ we denote by $\mathcal{M}_X(\mathbf{y}_+, \mathbf{y}_-; \mathbf{z})$ the moduli space of J^\diamond -holomorphic curves in X with boundary on $L_\alpha \cup L_\beta$ which are positively asymptotic to $[0, 1] \times \mathbf{y}_+$, negatively asymptotic to $[0, 1] \times \mathbf{y}_-$ and pass through \mathbf{z} . Note that $n_z(u) \geq 1$ for $u \in \mathcal{M}_X(\mathbf{y}_+, \mathbf{y}_-; \mathbf{z})$.

Definition 4.3.1. The *geometric U -map* with respect to the point \mathbf{z} is the map

$$U_{\mathbf{z}}([\mathbf{y}_+, i]) = \sum_{\mathbf{y}_- \in \mathcal{S}_{\alpha, \beta}} \sum_{j=1}^i \# \mathcal{M}_X^{L=2, n_z=j}(\mathbf{y}_+, \mathbf{y}_-; \mathbf{z}) [\mathbf{y}_-, i-j].$$

¹²What is called z here is called z^f in [13] and what is called \mathbf{z} here is called z in [13].

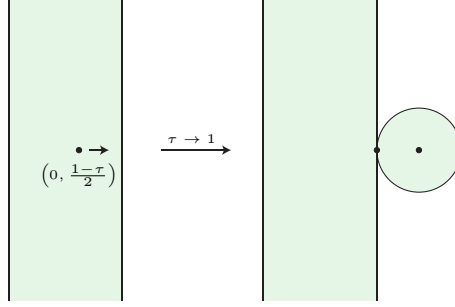

Figure 4.1: Moving the base point toward the boundary.

Note that the sum starts from $j = 1$ because if u passes through \mathbf{z} , then $n_z(u) \geq 1$ by positivity of intersection.

Standard arguments in symplectic geometry based on the compactness and gluing results of [80] show that the geometric U -map

$$U_{\mathbf{z}} : CF^+(\Sigma, \boldsymbol{\alpha}, \boldsymbol{\beta}, z) \rightarrow CF^+(\Sigma, \boldsymbol{\alpha}, \boldsymbol{\beta}, z)$$

is a chain map. The main result of the subsection is the following.

Theorem 4.3.2. *There exists a chain homotopy*

$$H : CF^+(\Sigma, \boldsymbol{\alpha}, \boldsymbol{\beta}, z) \rightarrow CF^+(\Sigma, \boldsymbol{\alpha}, \boldsymbol{\beta}, z)$$

such that

$$U_{\mathbf{z}} - U = H \circ \partial^+ + \partial^+ \circ H \quad (4.4)$$

and $H([\mathbf{y}, 0]) = 0$ for all $\mathbf{y} \in \mathcal{S}_{\boldsymbol{\alpha}, \boldsymbol{\beta}}$.

Proof. We will define a chain homotopy between $U_{\mathbf{z}}$ and U by moving \mathbf{z} towards the boundary and identifying a count of holomorphic curves in the limit configuration with the map U . More precisely, for $\tau \in [0, 1)$ we consider $\mathbf{z}_\tau = \{0\} \times \{\frac{1-\tau}{2}\} \times \{z\}$ and let J_τ^\diamond be a small deformation of J in a neighbourhood of \mathbf{z}_τ such that $\mathbb{R} \times [0, 1] \times \{z\}$ remains holomorphic for all τ . For $\tau = 0$ we have $\mathbf{z}_0 = \mathbf{z}$ and $J_0^\diamond = J^\diamond$.

Let $\mathcal{M}_X(\mathbf{y}_+, \mathbf{y}_-; \mathbf{z}_*)$ be the moduli space of J_τ^\diamond -holomorphic curves in X with boundary on $L_\alpha \cup L_\beta$ which are positively asymptotic to $[0, 1] \times \mathbf{y}_+$, negatively asymptotic to $[0, 1] \times \mathbf{y}_-$ and pass through \mathbf{z}_τ for some $\tau \in (0, 1)$. The map H is defined as

$$H([\mathbf{y}_+, i]) = \sum_{\mathbf{y}_- \in \mathcal{S}_{\boldsymbol{\alpha}, \boldsymbol{\beta}}} \sum_{j=1}^i \# \mathcal{M}_X^{I=1, n_z=j}(\mathbf{y}_+, \mathbf{y}_-; \mathbf{z}_*)[\mathbf{y}_-, i-j].$$

The structure of the boundary of the compactification of the moduli spaces $\mathcal{M}_X^{I=2}(\mathbf{y}_+, \mathbf{y}_-; \mathbf{z}_*)$ implies that H is a chain homotopy between $U_{\mathbf{z}}$ and a map

defined by counting certain broken holomorphic curves in the limit $\tau \rightarrow 1$. To finish the proof we need to identify this map with U . This will be done in the rest of the section. \square

In the limit $\tau \rightarrow 1$ a disc with an interior marked point bubbles off from the strip $\mathbb{R} \times [0, 1]$, and therefore we obtain $\tilde{X} = \tilde{B} \times \Sigma$ where $\tilde{B} = (B \sqcup D) / \sim$ with $B = \mathbb{R} \times [0, 1]$, $D = \{|x| \leq 1\} \subset \mathbb{C}$ and \sim identifies $(0, 0) \in B$ with $-1 \in D$. See Figure 4.1. For an appropriate choice of J_τ^\diamond , the limit almost complex structure is J on $B \times \Sigma$ and a small perturbation J_D^\diamond of a product almost complex structure J_D on $D \times \Sigma$ such that J_D^\diamond and J_D coincide outside of a small neighbourhood of $\mathbf{z}_1 = (0, z) \in D \times \Sigma$. From now on we write $\mathbf{z}_1 = \mathbf{z}$.

We define the ECH-type index I — in fact a relative version of Taubes’s index from [103] in this case — for a homology class $A \in H_2(D \times \Sigma, \partial D \times \beta)$ which admits a representative F such that each component of ∂F maps to a distinct component of $\partial D \times \beta$. Let (τ, τ') be the trivialisation of $T(D \times \Sigma)$ along $\partial D \times \beta$ such that τ is induced by a radial and outward-pointing vector field along ∂D tangent to D , and τ' is induced by a vector field along β tangent to Σ and transverse to β . Let $Q_{(\tau, \tau')}(A)$ be the intersection number between F and a push-off of F , where ∂F is pushed along τ' . We define¹³

$$I(A) = c_1(T(D \times \Sigma)|_A, (\tau, \tau')) + Q_{(\tau, \tau')}(A). \quad (4.5)$$

If u is a holomorphic curve in $D \times \Sigma$ with boundary on $\partial D \times \beta$ representing a relative homology class A as above, then by the index inequality

$$I(A) = \text{ind}(u) + 2\delta(u). \quad (4.6)$$

In particular u is an embedding if and only if $\text{ind}(u) = I(A)$. See [14, Theorem 4.5.13] for the proof of a similar result. Let $A_{k_0, k_1} = k_0[D \times \{pt\}] + k_1[\{pt\} \times \Sigma]$. If $k_0 \leq g$, where g is the genus of Σ , an easy computation gives

$$I(A_{k_0, k_1}) = k_0 + k_1(2 - 2g) + 2k_0k_1. \quad (4.7)$$

In particular, $I(A_{g, k_1}) = 2k_1 + g$.

We fix points¹⁴ $y_i \in \beta_i$ for $i = 1, \dots, g$ and denote by $\mathcal{M}_{D \times \Sigma}(A_{k_0, k_1}; \mathbf{z}, \mathbf{y})$ the moduli space of J_D^\diamond -holomorphic curves in $D \times \Sigma$ with boundary on $\partial D \times \beta$ representing the homology class A_{k_0, k_1} and passing through $(z, 0)$ and k_0 points of the form $(-1, y_i)$.

Remark 4.3.3. If $k_1 \leq 0$, a standard compactness argument shows that the moduli spaces $\mathcal{M}_{D \times \Sigma}(A_{k_0, k_1}; \mathbf{z}, \mathbf{y})$ are empty, provided that J_D^\diamond is close enough to a product almost complex structure.

¹³The formula in [13, Definition 3.2.1] has an extra term $\mu_{(\tau, \tau')}(\partial A)$, which vanishes here by our choice of trivialisation.

¹⁴These points are called w_i in [13].

Lemma 4.3.4. *Let u_{τ_i} , for $\tau_i \rightarrow 1$ as $i \rightarrow \infty$, be a sequence of $J_{\tau_i}^\diamond$ -holomorphic curves in $\mathcal{M}_X^{I=2, n_z=j}(\mathbf{y}_+, \mathbf{y}_-; \mathbf{z}_{\tau_i})$ for some fixed $\mathbf{y}_\pm \in \mathcal{S}_{\alpha, \beta}$ and $j > 0$. Then, up to passing to a subsequence, u_{τ_i} converges to a pair of holomorphic curves (u_B, u_D) where u_B is a union of trivial strips $B \times \{\mathbf{y}\}$ in $B \times \Sigma$ over an intersection point $\mathbf{y} \in \mathcal{S}_{\alpha, \beta}$ and $u_D \in \mathcal{M}_{D \times \Sigma}(A_{g,1}; \mathbf{z}, \mathbf{y})$. In particular $\mathbf{y}_+ = \mathbf{y}_- = \mathbf{y}$ and $j = 1$.*

Proof. By Gromov compactness a subsequence of u_{τ_i} converges to a pair (u_B, u_D) where u_B is a J -holomorphic curve in $\mathcal{M}_X(\mathbf{y}_+, \mathbf{y}_-)$ and u_D is a J_D^\diamond -holomorphic curve in $\mathcal{M}_{D \times \Sigma}(A_{g,k_1}; \mathbf{z}, \mathbf{y})$ for some $\mathbf{y} = (y_1, \dots, y_g)$. A simple computation shows that

$$I(u_B) + I(u_D) = 2 - g. \quad (4.8)$$

By Equation(4.7) we can rewrite Equation (4.8) as $I(u_B) + 2k_1 = 2$. Since $k_1 \geq 1$ by Remark 4.3.3 and $I(u_B) \geq 0$, this implies that $I(u_B) = 0$ and $k_1 = 1$; in particular u_B is a union of trivial strips and therefore $\mathbf{y}_\pm = \mathbf{y}$ and $j = 1$. \square

The moduli spaces $\mathcal{M}_{D \times \Sigma}(A_{g,1}; \mathbf{z}, \mathbf{y})$ are zero dimensional and consist of embedded J_D^\diamond -holomorphic curves by Equations (4.6) and (4.7). We denote

$$G(g) = \#\mathcal{M}_{D \times \Sigma}(A_{g,1}; \mathbf{z}, \mathbf{y}).$$

Thus, by Lemma 4.3.4, H is a homotopy between $U_{\mathbf{z}}$ and $G(g)U$. In order to compute $G(g)$ we further degenerate $D \times \Sigma$. The first step is to degenerate D into $D \cup S^2$, where $0 \in D$ is identified with $\infty \in S^2 \cong \mathbb{C} \cup \{\infty\}$ and $\mathbf{z} = (0, z) \in S^2 \times \Sigma$. Let J_S^\diamond denote the limit almost complex structure on $S^2 \times \Sigma$, which we assume to be a small perturbation of a product almost complex structure J_S in a small neighbourhood of \mathbf{z} .

Holomorphic curves in $\mathcal{M}_{D \times \Sigma}(A_{g,1}; \mathbf{z}, \mathbf{y})$ degenerate into pairs of curves consisting in the trivial multisection $D \times \{\mathbf{y}\}$ in $D \times \Sigma$ and a J_S^\diamond -holomorphic curve in $S^2 \times \Sigma$ representing the homology class $B_{g,1} = g[S^2] + [\Sigma]$ and passing through the points $\mathbf{z} = (0, z)$ and $(\infty, y_1), \dots, (\infty, y_g)$. We denote the moduli space of such curves by $\mathcal{M}_{S^2 \times \Sigma}(B_{g,1}; \mathbf{z}, \mathbf{y})$.

Holomorphic curves in $\mathcal{M}_{S^2 \times \Sigma}(B_{g,1}; \mathbf{z}, \mathbf{y})$ can be reducible and only the irreducible component passing through $(0, z)$ has to be regular. We denote the subset of $\mathcal{M}_{S^2 \times \Sigma}(B_{g,1}; \mathbf{z}, \mathbf{y})$ consisting of irreducible J_S^\diamond -holomorphic curves by $\mathcal{M}_{S^2 \times \Sigma}^{irr}(B_{g,1}; \mathbf{z}, \mathbf{y})$. Simple index considerations taking into account the homological and point constraints imply that the elements in $\mathcal{M}_{S^2 \times \Sigma}(B_{g,1}; \mathbf{z}, \mathbf{y}) \setminus \mathcal{M}_{S^2 \times \Sigma}^{irr}(B_{g,1}; \mathbf{z}, \mathbf{y})$ consist of $\{\infty\} \times \Sigma$ with g spheres in the class $[S^2]$, one of which passes through $(0, z)$. However these curves cannot be glued to the g sections $D \times \{y_i\}$ on $D \times \Sigma$ — in fact topological considerations prevent even the existence of a pregluing. Thus we have proved that

$$G(g) = \#\mathcal{M}_{S^2 \times \Sigma}^{irr}(B_{g,1}; \mathbf{z}, \mathbf{y}).$$

The following lemma completes the proof of Theorem 4.3.2.

Lemma 4.3.5. $G(g) = 1$ for all $g \geq 1$.

Proof. In the proof we will degenerate Σ along $g-1$ separating curves in order to obtain a nodal surface $\tilde{\Sigma}$ whose irreducible components are tori. We choose the curves so that each irreducible component contains exactly one of the points y_i . Since the base point \mathbf{z} remains in one component, the almost complex structure on $S^2 \times \tilde{\Sigma}$ is a product almost complex structure in all but one of the irreducible components of $S^2 \times \tilde{\Sigma}$. Since a product almost complex structure is not generic enough, before degenerating Σ we need to modify J_S^\diamond . To this aim we introduce a generic almost complex structure J_S^\heartsuit on $D \times \Sigma$ among those making the projection $S^2 \times \Sigma \rightarrow \Sigma$ into a holomorphic map and keeping the section $\{\infty\} \times \Sigma$ holomorphic.¹⁵ The cardinality of the set $\mathcal{M}_{S^2 \times \Sigma}^{irr}(B_{g,1}; \mathbf{z}, \mathbf{y})$ is the same for J_S^\diamond and J_S^\heartsuit ; from now on we will work with the latter almost complex structure.

As Σ degenerates towards $\tilde{\Sigma}$, holomorphic curves in $\mathcal{M}_{S^2 \times \Sigma}^{irr}(B_{1,g}; \mathbf{z}, \mathbf{y})$ degenerate into holomorphic curves in $S^2 \times \tilde{\Sigma}$, with the same point constraints, which are irreducible in each irreducible component of $S^2 \times \tilde{\Sigma}$, and such that two irreducible components meet at one point when two irreducible components of $S^2 \times \tilde{\Sigma}$ meet. This shows that $G(g) = G(1)^g$.

It remains to compute $G(1)$. When $g = 1$, there are two (reducible) J_S -holomorphic curves (i.e. for a product almost complex structure) passing through $(0, z)$ and (∞, y) : one with image $S^2 \times \{z\} \cup \{\infty\} \times \Sigma$ and the other one with image $\{0\} \times \Sigma \cup S^2 \times \{y\}$. As stated in [87, Example 8.6.12], the latter deforms into an irreducible J_S^\heartsuit -holomorphic curve passing through $(0, z)$ and (∞, y) and giving $G(1) = 1$. \square

4.3.3 Adapting \widehat{HF} to an open book decomposition

Let M be a closed three-manifold, $B \subset M$ a link, S a compact, oriented, connected surface with nonempty boundary, and $h: S \rightarrow S$ an orientation-preserving diffeomorphism such that $h|_{\partial S} = id$.

Definition 4.3.6. An *open book decomposition* of M with *binding* B , *page* S and *monodromy* h is a locally trivial fibration $\pi: M \setminus B \rightarrow S^1$ with fibre $int(S)$ and monodromy h such that the closure of any fibre is a surface with boundary whose boundary is B . The pair (S, h) is called an *abstract open book decomposition*.

In this section we explain how to associate a pointed Heegaard diagram to an open book decomposition and compute $\widehat{HF}(-M)$ from the page and the

¹⁵The section $\{\infty\} \times \Sigma$ is not regular, and thus neither J_S^\diamond nor J_S^\heartsuit are generic almost complex structures. What we are computing here are a simple instance of *relative* Gromov-Witten invariants in the sense of [68].

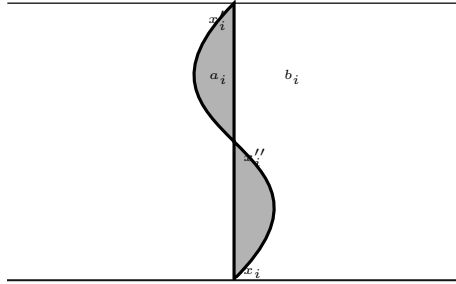

Figure 4.2: A portion of S_1 . The shaded regions are the “thin strips” D_i and D'_i which connect x''_i to x_i or x'_i .

monodromy, using a construction from [59]. From now on we assume that ∂S is connected and S has genus g .

We identify $S^1 \cong [0, 2]/0 \sim 2$. An open book decomposition with page S and monodromy h gives rise to a Heegaard decomposition $M = H_\alpha \cup H_\beta$, where $H_\alpha = \overline{\pi^{-1}([0, 1])}$, $H_\beta = \overline{\pi^{-1}([1, 2])}$, and the Heegaard surface $\Sigma = S_1 \cup -S_0$ is the union of two pages¹⁶ glued along the binding.

A *basis of arcs* for S is a collection of $2g$ pairwise disjoint properly embedded arcs $\mathbf{a} = \{a_1, \dots, a_{2g}\}$ in S such that $S \setminus \mathbf{a}$ is a connected polygon. Starting from a basis \mathbf{a} for S , we can construct α - and β -curves for Σ as follows:

$$\alpha = (\mathbf{a} \times \{1\}) \cup (\mathbf{a} \times \{0\}) \quad \text{and} \quad \beta = (\mathbf{b} \times \{1\}) \cup (h(\mathbf{a}) \times \{0\}).$$

Here \mathbf{b} is a small deformation of \mathbf{a} relative to its endpoints, so that each pair a_i and b_i intersects each other transversely at three points: two of the intersections are their endpoints x_i and x'_i on ∂S and the third intersection is an interior point x''_i ; see Figure 4.2. This means that all the intersection points of α and β lie in S_0 , with the exception of the points $x''_i = x''_i \times \{1\}$. We place the base point z on S_1 , away from the “thin strips” D_i and D'_i , $i = 1, \dots, 2g$, given in Figure 4.2. The positioning of z prevents holomorphic curves involved in the differential for $\widehat{CF}(-\Sigma, \alpha, \beta, z)$ — besides the ones corresponding to the thin strips — from entering S_1 . Hence all of the nontrivial holomorphic curve information is concentrated on S_0 . Here the homology of $\widehat{CF}(-\Sigma, \alpha, \beta, z)$ is isomorphic to $\widehat{HF}(-M)$ since we reversed the orientation of Σ .

Let $\mathcal{S}_{\mathbf{a}, h(\mathbf{a})} \subset \mathcal{S}_{\alpha, \beta}$ consist of $2g$ -tuples \mathbf{y} , all of whose components are intersections are in S_0 . We define¹⁷ $\widehat{CF}(S, \mathbf{a}, h(\mathbf{a}))$ as the chain complex generated by $\mathcal{S}_{\mathbf{a}, h(\mathbf{a})}$ and whose differential counts holomorphic curves in $\mathbb{R} \times [0, 1] \times S$. Then we define $\widehat{CF}(S, \mathbf{a}, h(\mathbf{a}))$ as the quotient of $\widehat{CF}(S, \mathbf{a}, h(\mathbf{a}))$ modulo the identifications $\{x_i\} \cup \mathbf{y}_0 \sim \{x'_i\} \cup \mathbf{y}_0$ for all $(2g - 1)$ -tuples of chords \mathbf{y}_0 . The quotient

¹⁶We call a page not only the abstract surface S , but also all surfaces $S_t = \overline{\pi^{-1}(t)}$.

¹⁷The same chain complex is called $\widehat{CF}'(S, \mathbf{a}, h(\mathbf{a}))$ in [14].

inherits a differential because no holomorphic curve in $\mathbb{R} \times [0, 1] \times S$ can have a positive end at one of the chords over x_i, x'_i unless it has an irreducible component which is a trivial strip over that chord by [14, Claim 4.9.2], and therefore we are quotienting by a subcomplex. The identifications $\{x_i\} \cup \mathbf{y}_0 \sim \{x'_i\} \cup \mathbf{y}_0$ are the algebraic consequence of the thin strips D_i and D'_i . The following proposition was proved in [14, Theorem 4.9.4]:

Proposition 4.3.7. $\widehat{HF}(S, \mathbf{a}, h(\mathbf{a}), z) \simeq \widehat{HF}(-\Sigma, \boldsymbol{\alpha}, \boldsymbol{\beta}, z)$.¹⁸

Remark 4.3.8. $\mathbf{x} = \{x_1, \dots, x_{2g}\}$ is a cycle and its homology class $[\mathbf{x}] \in \widehat{HF}(-M)$ is the contact invariant of the contact structure supported by the open book decomposition; see [59].

4.4 Embedded contact homology

4.4.1 A review of embedded contact homology

In this subsection we briefly review the embedded contact homology groups associated to a closed three-manifold M . Embedded contact homology was defined by Hutchings [60] and Hutchings-Taubes [63, 64] and is intimately connected with the dynamics of Reeb vector fields. Invariance was shown by Taubes in [104, 105, 106, 107, 108] by proving an isomorphism between embedded contact homology and monopole Floer homology.

Let α be a contact form on M . We assume that every closed Reeb orbit is *non-degenerate*, which means that its linearised first return map does not have 1 as an eigenvalue. Contact forms satisfying this property are called *nondegenerate*. The linearised first return map is a symplectic transformation, and therefore its eigenvalues are $\{\lambda, \lambda^{-1}\}$, where λ is either real or in the unit circle. Then a closed Reeb orbit is:

- *hyperbolic* if the eigenvalues of its linearised first return map are real, or
- *elliptic* if they lie on the unit circle.

The chain complex $ECC(M, \alpha)$ is generated by finite sets $\gamma = \{(\gamma_i, m_i)\}$, called *orbit sets*, where:

- γ_i is a simple closed Reeb orbit,
- m_i is a positive integer, and
- if γ_i is a hyperbolic orbit, then $m_i = 1$.

¹⁸Here we consider $\widehat{HF}(-\Sigma, \boldsymbol{\alpha}, \boldsymbol{\beta}, z)$ and there $\widehat{HF}(\Sigma, \boldsymbol{\beta}, \boldsymbol{\alpha}, z)$. The two groups are isomorphic.

We will denote the set of orbit sets by \mathcal{O} . An orbit set γ will also be written multiplicatively as $\prod \gamma_i^{m_i}$, with the convention that $\gamma_i^2 = 0$ whenever γ_i is hyperbolic. The empty orbit set \emptyset will be written multiplicatively as 1.

We choose an almost complex structure J on $\mathbb{R} \times M$ compatible with α . Let $\gamma_+ = \{(\gamma_i^+, m_i^+)\}$ and $\gamma_- = \{(\gamma_i^-, m_i^-)\}$ be orbit sets. We denote by $\mathcal{M}(\gamma_+, \gamma_-)$ the moduli space of J -holomorphic curves in $\mathbb{R} \times M$ which are positively asymptotic to covers of the closed Reeb orbits γ_i^+ with total multiplicity m_i^+ as $s \rightarrow +\infty$ and negatively asymptotic to covers of the closed Reeb orbits γ_i^- with total multiplicity m_i^- as $s \rightarrow -\infty$. Moreover, we consider equivalent two J -holomorphic curves which differ only by (branched) covers of trivial cylinders with the same multiplicity. Translations in the \mathbb{R} direction acts on the moduli spaces; we denote the quotient by $\widehat{\mathcal{M}}(\gamma_+, \gamma_-)$.

The ECH index for J -holomorphic curves in $\mathbb{R} \times M$ is defined in [60, Definition 1.5]. The following lemma is a consequence of the index inequality proved in [61, Theorem 4.15].

Lemma 4.4.1 ([63, Proposition 7.15]). *Let J be a generic almost complex structure compatible with α . Then:*

1. *A J -holomorphic curve u with $I(u) = 0$ is a union of branched covers of trivial cylinders over simple closed Reeb orbits. (Such curves are called connectors.)*
2. *A J -holomorphic curve u with $I(u) = 1$ (resp. 2) is a disjoint union of a connector and an embedded J -holomorphic curve u' with $I(u') = \text{ind}(u') = 1$ (resp. 2).*

The ends of a J -holomorphic curve u in $\mathcal{M}(\gamma_+, \gamma_-)$ without connector components determine partitions of the multiplicities of the elliptic orbits in γ_+ and γ_- . It turns out that, when $I(u) = 1$ or $I(u) = 2$, these partitions must coincide with preferred partitions called the *outgoing* and *incoming* partitions for positive and negative ends, respectively. The incoming and outgoing partitions can be computed from the dynamics of the linearised Reeb flow. For their definition see [60, Section 4.1] or [61, Definition 4.14]. For the relation between these partitions and the ECH index see [61, Theorem 4.15], for example. In this chapter we will not need the precise definition of those partitions, except for the following fact, which is a direct consequence of [61, Definition 4.14].

Lemma 4.4.2. *Let γ be a simple elliptic orbit and suppose that its linearised Reeb flow is conjugated to a rotation by an angle $2\pi\theta$. If $0 < \theta < \frac{1}{m}$, then the incoming partition of (γ, m) is (m) and the outgoing partition is $(\underbrace{1, \dots, 1}_m)$.*

On the other hand, if $-\frac{1}{m} < \theta < 0$, then the incoming partition of (γ, m) is $(\underbrace{1, \dots, 1}_m)$ and the outgoing partition is (m) .

The differential on $ECC(M, \alpha)$ is defined as

$$\partial\gamma_+ = \sum_{\gamma_- \in \mathcal{O}} \#\widehat{\mathcal{M}}^{I=1}(\gamma_+, \gamma_-)\gamma_-.$$

The map ∂ was shown to satisfy $\partial^2 = 0$ by Hutchings and Taubes in [63, 64]. The homology of $ECC(M, \alpha)$ is the *embedded contact homology* group $ECH(M)$. It is independent of the choice of contact form α , contact structure ξ , and compatible almost complex structure J by the work of Taubes in [104, 105, 106, 107, 108] showing the isomorphism with monopole Floer homology.

Remark 4.4.3. The moduli spaces $\mathcal{M}(\gamma_+, \gamma_-)$ can be nonempty only if γ_+ and γ_- define the same homology class. Thus $ECC(M, \alpha)$ decomposes as a direct sum of complexes indexed by classes in $H_1(M; \mathbb{Z})$. This decomposition, which in $ECH(M)$ depends on α only through the Euler class of the contact structure it defines, is analogous to the decomposition of the Heegaard Floer complexes according to Spin^c structures.

Given a point $\mathbf{z} \in \mathbb{R} \times M$, we denote by $\mathcal{M}(\gamma_+, \gamma_-; \mathbf{z})$ the moduli space of J -holomorphic curves asymptotic to γ_{\pm} and passing through \mathbf{z} where, as before, we identify curves which differ by a connector component. For a generic point \mathbf{z} , the map¹⁹ $U: ECC(M, \alpha) \rightarrow ECC(M, \alpha)$ is defined as

$$U(\gamma_+) = \sum_{\gamma_- \in \mathcal{O}} \#\mathcal{M}^{I=2}(\gamma_+, \gamma_-; \mathbf{z})\gamma_-.$$

The same techniques used to show that $\partial^2 = 0$ also show that U is a chain map; see [65, Section 2.5] for more details. Then $\widehat{ECC}(M, \alpha)$ is defined as the cone of U and $\widehat{ECH}(M)$ is its homology. As before, the isomorphism with monopole Floer homology proved by Taubes shows that $\widehat{ECH}(M)$ is invariant of all choices.

4.4.2 Morse-Bott theory for embedded contact homology

In several steps of the proof of Theorem 4.1.1 we will use Morse-Bott techniques extensively. Here we will give a brief description of those techniques and refer the reader to [3] and [4] for a general treatment and to [12, Section 4] for one which is more adapted to embedded contact homology. For the purposes of this paper, a contact form is *Morse-Bott* if every closed orbit of its Reeb vector field is either isolated and nondegenerate, or belongs to an S^1 -family and is nondegenerate in the normal direction.²⁰ We denote a Morse-Bott S^1 -family of

¹⁹This map is called U' in [13].

²⁰In general, there is also the case where the Reeb orbits come in two-dimensional families; however this will not occur here.

simple closed Reeb orbits by \mathcal{N} and the Morse-Bott torus corresponding to \mathcal{N} by $T_{\mathcal{N}} = \bigcup_{x \in \mathcal{N}} x$.

Let $\{v_1, v_2\}$ be an oriented basis for ξ at some point $p \in T_{\mathcal{N}}$ so that v_1 is transverse to $T_{\mathcal{N}}$ and v_2 is tangent to $T_{\mathcal{N}}$. The linearised first return map of the Reeb flow on ξ_p is given, in the basis $\{v_1, v_2\}$, by the matrix $\begin{pmatrix} 1 & 0 \\ a & 1 \end{pmatrix}$ with $a \neq 0$.

Definition 4.4.4. $T_{\mathcal{N}}$ is called a *positive* Morse-Bott torus if $a > 0$ and a *negative* Morse-Bott torus if $a < 0$.

A Morse-Bott contact form α can be perturbed into nondegenerate forms α_ϵ , for $\epsilon > 0$ sufficiently small, which depend on the choice of a Morse function on each Morse-Bott S^1 -family. The close Reeb orbits of the forms α_ϵ will be the nondegenerate closed Reeb orbits of α together with the closed Reeb orbits in the Morse-Bott tori corresponding to the critical points of the Morse functions on the Morse-Bott families. We will swipe under the carpet the actual construction of the contact forms α_ϵ and the fact that they are nondegenerate only up to orbits of some action (i.e. period) L_ϵ , with $L_\epsilon \rightarrow +\infty$ as $\epsilon \rightarrow 0$, so that a limiting procedure is involved in computing $ECH(M)$ from a Morse-Bott contact form.

If we choose a family of almost complex structures J_ϵ compatible with α_ϵ and converging to an almost complex structure J compatible with α as $\epsilon \rightarrow 0$, a sequence of J_ϵ -holomorphic curves converges into a “cascade” of J -holomorphic curves some of whose ends are connected to negative gradient trajectories in the Morse-Bott families. The negative gradient trajectories which can appear are of three types:

- flow-lines between critical points,
- semi-infinite trajectories between a critical point and an end of a holomorphic piece of the cascade, and
- finite trajectories joining a positive and a negative end of different holomorphic pieces.

See [4, Section 11.2] for a precise statement.

The converse is more delicate: a cascade of J -holomorphic curves whose ends are joined by negative gradient flow trajectories in general cannot be deformed to a J_ϵ -holomorphic curve without using some abstract perturbation theory which has not been rigorously established yet. The main problem is that a family of simply covered J_ϵ -holomorphic curves — which are thus regular for a generic J_ϵ — could degenerate into a cascade in which some of the holomorphic curves are multiply covered and could even have negative Fredholm index.

We will therefore restrict our attention to a special class of Morse-Bott cascades in which finite negative gradient trajectories are not allowed and at most one of

the holomorphic pieces is not a cover of a trivial cylinder. Those cascades are called *very nice Morse-Bott buildings* in [12]. Let $\gamma_{\pm} = \{(\gamma_i^{\pm}, m_i^{\pm})\}$ be orbit sets where each γ_i^{\pm} is either a nondegenerate closed Reeb orbit of α or a closed Reeb orbit corresponding to a critical point of the Morse function on a Morse-Bott family. We denote²¹ by $\mathcal{M}^{MB}(\gamma_+, \gamma_-)$ the moduli space of very nice Morse-Bott buildings in $\mathbb{R} \times M$ with positive ends at γ_+ and negative ends at γ_- . We denote by $\widehat{\mathcal{M}}^{MB}(\gamma_+, \gamma_-)$ the quotient by translations and by $\mathcal{M}^{MB}(\gamma_+, \gamma_-; \mathbf{z})$ the subspace of those cascades passing through a generic point $\mathbf{z} \in \mathbb{R} \times M$. In the Appendix to [12] we prove that every very nice J -holomorphic building can be perturbed to a J_{ϵ} holomorphic curve for ϵ sufficiently small. Hence we have the following theorem.

Theorem 4.4.5. *For a generic almost complex structure J compatible with α and ϵ sufficiently small there are injections*

$$\begin{aligned} \widehat{\mathcal{M}}^{MB, I=1}(\gamma_+, \gamma_-) &\hookrightarrow \widehat{\mathcal{M}}^{I=1}(\gamma_+, \gamma_-) \quad \text{and} \\ \mathcal{M}^{MB, I=2}(\gamma_+, \gamma_-; \mathbf{z}) &\hookrightarrow \mathcal{M}^{I=2}(\gamma_+, \gamma_-; \mathbf{z}) \end{aligned}$$

where the moduli spaces on the left hand side are defined using the almost complex structure J and the moduli spaces on the right hand side are defined using a perturbed almost complex structure J_{ϵ} .

4.4.3 Embedded contact homology of manifolds with torus boundary

In this section we define several flavours of embedded contact homology for manifolds with torus boundary; see [12, Section 7] for more details. Let N be a three-manifold with $\partial N \cong T^2$ and let α be a contact form on N such that ∂N is foliated by Reeb orbits. We assume that the foliation is linear for some choice of coordinates in ∂N . Then, we say that α is *rational* if the Reeb orbits on ∂N are closed, and *irrational* if they are dense. If α is rational, we assume that ∂N is a Morse-Bott torus. We choose a Morse function with a unique maximum and minimum on the corresponding Morse-Bott S^1 -family. After perturbing α using this Morse function²², the Morse-Bott family of orbits foliating ∂N is replaced by a pair of nondegenerate orbits: an elliptic one called e and a hyperbolic one called h . If ∂N is a positive Morse-Bott torus, then e comes from the maximum and h from the minimum, while if ∂N is negative, then h comes from the maximum and e from the minimum. In the following definitions we will assume that ∂N is a negative Morse-Bott torus when α is rational. The similar definitions in the positive case are left to the reader.

²¹In [12] the same moduli spaces are denoted by $\mathcal{M}^{MB, vn}(\gamma_+, \gamma_-)$ because they consist of very nice Morse-Bott buildings.

²²To perform the perturbation it is convenient to enlarge N slightly; we will ignore this technical point.

Definition 4.4.6. The chain complex $ECC(int(N), \alpha)$ is generated by orbit sets contained in the interior of N and the differential is defined by counting J -holomorphic curves in $\mathbb{R} \times int(N)$.

This definition makes sense because the foliation by Reeb orbits in ∂N prevents J -holomorphic curves with asymptotics in $int(N)$ from touching ∂N by positivity of intersection. (Alternatively, we can say that $\mathbb{R} \times \partial N$ is a Levi-flat²³ surface.)

Definition 4.4.7. The chain complex $ECC(N, \alpha)$ coincides with $ECC(int(N), \alpha)$ if α is irrational, and is generated by orbit sets built from closed Reeb orbits in $int(N)$ plus e and h on ∂N . The differential counts very nice Morse-Bott buildings contained in $\mathbb{R} \times N$.

The proof that this definition makes sense consists in showing that a one-dimensional family of very nice Morse-Bott buildings in $\mathbb{R} \times N$ cannot break into a non very nice Morse-Bott building; see [12, Lemma 7.12]. This is a consequence of the fact that, by the trapping lemma [12, Lemma 5.3.2], positive ends of J -holomorphic curves in $\mathbb{R} \times N$ at the closed Reeb orbits foliating ∂N must be trivial.

Definition 4.4.8. The chain complex $ECC^b(N, \alpha)$ is generated by orbit sets built from closed Reeb orbits in $int(N)$ plus e and the chain complex $ECC^\sharp(N, \alpha)$ is generated by orbit sets built from closed Reeb orbits in $int(N)$ plus h .

Both $ECC^b(N, \alpha)$ and $ECC^\sharp(N, \alpha)$ are subcomplexes of $ECC(N, \alpha)$ because e and h can appear only at the negative end of a very nice Morse-Bott building, except for connectors and two negative gradient flow trajectories from h to e in their Morse-Bott family.

Invariance was addressed only for $ECH(N, \alpha)$ when α is an irrational contact form; for the other flavours it will not be needed.

Proposition 4.4.9 ([12, Proposition 7.2.1]). *Let α_1 and α_2 be contact forms on N which agree on ∂N to first order (and in particular the Reeb vector fields and the characteristic foliations of α_1 and α_2 on ∂M are equal) and define contact structures $\xi_i = \ker \alpha_i$ which are isotopic relative to the boundary. If ∂N is foliated by Reeb orbits of irrational slope, then there is an isomorphism*

$$ECH(N, \alpha_1) \cong ECH(N, \alpha_2).$$

The strategy of the proof is to extend (N, α_i) , $i = 1, 2$, to closed contact manifolds so that the closed Reeb orbits not contained in N have much larger action and to use the action properties of the continuation maps for embedded contact homology of closed three-manifolds.

²³Named after Eugenio Elia Levi, an Italian mathematician who was killed in action during WWI. His brother Beppo Levi was forced into exile by the fascist racial laws of 1938.

When ∂N is a negative Morse-Bott torus, we define two further versions of embedded contact homology for (N, α) which are, in some sense, embedded contact homology groups relative to the boundary. We recall that $ECC(N, \alpha)$ can be seen as a commutative algebra generated by simple closed Reeb orbits with the relation that $\gamma^2 = 0$ if γ is hyperbolic. Let $\langle e-1 \rangle$ be the ideal generated by $e-1$. Even if the differential does not respect the multiplicative structure, this ideal is a subcomplex because only connectors can have e at a positive end. We define

$$\begin{aligned} ECC(N, \partial N, \alpha) &= ECC^b(N, \alpha) / \langle e-1 \rangle \quad \text{and} \\ \widehat{ECC}(N, \partial N, \alpha) &= ECC(N, \alpha) / \langle e-1 \rangle. \end{aligned}$$

We denote the differential in $ECC(N, \partial N, \alpha)$ by ∂_{rel} and in $\widehat{ECC}(N, \partial N, \alpha)$ by $\widehat{\partial}_{rel}$. Factoring out h , we can decompose $\widehat{\partial}_{rel}$ as follows. If γ is an orbit set not containing h , we can write

$$\begin{aligned} \widehat{\partial}_{rel}(\gamma) &= \partial_{rel}(\gamma) + hU_{rel}(\gamma) \\ \widehat{\partial}_{rel}(h\gamma) &= h\widehat{\partial}_{rel}(\gamma). \end{aligned}$$

From $(\widehat{\partial}_{rel})^2 = 0$ we deduce that the map

$$U_{rel}: ECC(N, \partial N, \alpha) \rightarrow ECC(N, \partial N, \alpha)$$

is a chain map and $\widehat{ECC}(N, \partial N, \alpha)$ is the cone of U_{rel} . The name of U_{rel} is motivated by the fact that it plays the role of the map U in embedded contact homology relative to the boundary.

Given $a \in H_1(N; \mathbb{Z})$, let $ECC_a(N, \alpha)$ be the subcomplex of $ECC(N, \alpha)$ generated by orbit sets in the homology class a . The same notation is used for the sharp and flat flavours. From the fact that only connectors can have e at a positive end, it is easy to see that the map

$$\begin{aligned} ECC_a(N, \alpha) &\rightarrow ECC_{a+[e]}(N, \alpha) \\ \gamma &\mapsto e\gamma \end{aligned}$$

is a chain map.

If $\bar{a} \in H_1(N; \mathbb{Z}) / \langle [e] \rangle$, we denote by $ECC_{\bar{a}}(N, \partial N, \alpha)$ the subcomplex of $ECC(N, \partial N, \alpha)$ generated by orbit sets in the class \bar{a} . Note that $H_1(N; \mathbb{Z}) / \langle [e] \rangle$ is the first homology group of the closed manifold obtained by Dehn filling N along the slope of e . The following lemma is almost immediate.

Lemma 4.4.10. *Suppose $[e] \neq 0$ in $H_1(N; \mathbb{Z})$. If $a \in H_1(N; \mathbb{Z})$ and \bar{a} is its image in $H_1(N; \mathbb{Z}) / \langle [e] \rangle$, then*

$$\begin{aligned} ECH_{\bar{a}}(N, \partial N, \alpha) &= \varinjlim \left\{ ECH_{a+j[e]}^b(N, \alpha) \right\}_{j \in \mathbb{N}} \\ \widehat{ECH}_{\bar{a}}(N, \partial N, \alpha) &= \varinjlim \left\{ ECH_{a+j[e]}(N, \alpha) \right\}_{j \in \mathbb{N}}. \end{aligned}$$

The relation between embedded contact homology of N relative to the boundary and embedded contact homology of the Dehn filling of N along the slope of e is the main result of [12]. The following theorem is a generalisation of [12, Theorem 1.1.1], expressed in a slightly different language.

Theorem 4.4.11. *Let N be a three-manifold with torus boundary and let α be a contact form on N such that ∂N is a negative Morse-Bott torus for the Reeb vector field. Let moreover M be the Dehn filling of N along the slope of e . If there is a cohomology class $\varphi \in H^1(N; \mathbb{Z})$ such that $\varphi([\gamma]) \geq 0$ for all closed Reeb orbit γ and $\varphi([e]) > 0$, then there exist isomorphisms*

$$\begin{aligned}\sigma_* &: ECH(N, \partial N, \alpha) \rightarrow ECH(M), \\ \widehat{\sigma}_* &: \widehat{ECH}(N, \partial N, \alpha) \rightarrow \widehat{ECH}(M)\end{aligned}$$

such that the diagram

$$\begin{array}{ccccccc} \dots & \longrightarrow & \widehat{ECH}(N, \partial N) & \longrightarrow & ECH(N, \partial N) & \xrightarrow{U_{rel}} & ECH(N, \partial N) & \longrightarrow & \dots \\ & & \downarrow \widehat{\sigma}_* & & \downarrow \sigma_* & & \downarrow \sigma_* & & \\ \dots & \longrightarrow & \widehat{ECH}(M) & \longrightarrow & ECH(M) & \xrightarrow{U} & ECH(M) & \longrightarrow & \dots \end{array}$$

commutes. Moreover, the maps σ_* and $\widehat{\sigma}_*$ are compatible with the direct sum decompositions according to homology classes.

The proof of Theorem 4.4.11 will be sketched in the next subsection. A heuristic reason why it is expected to hold is the following. Let α_δ , $0 < \delta \ll 1$, be a family of contact forms on $M = N \cup V$ such that, on the solid torus $V \cong D^2 \times (\mathbb{R}/\mathbb{Z})$ with cylindrical coordinates (r, θ, z) , their Reeb vector fields R_δ are tangent to the concentric tori $\{r = \text{const}\}$ and have constant slope $\frac{1}{\delta}$ (away from the core). As we send $\delta \rightarrow 0$, the Conley-Zehnder index of the core goes to $+\infty$ and we should therefore be able to ignore it. At the same time, one expects that $I_{ECH} = 1$ holomorphic curves that cross the core when $\delta > 0$ should be in one-to-one correspondence with holomorphic curves which have e at the negative end when $\delta = 0$. This is the reason for identifying $e = 1$. Similarly, if we place the marked point z on the core and h correspondingly, then $I_{ECH} = 2$ holomorphic curves that pass through z should be in one-to-one correspondence with $I_{ECH} = 1$ holomorphic curves which have h at a negative end when $\delta = 0$.

4.4.4 How to prove Theorem 4.4.11

A special contact form on M

Let α be a contact form on N which is nondegenerate in $\text{int}(N)$ and has a negative Morse-Bott torus of closed Reeb orbits at ∂N . To keep the discussion

closer to [12] we assume that there is a properly embedded surface $S \subset N$ such that $[\partial S] \cdot [e] = 1$ and the Reeb vector field of α is positively transverse to S . This ensures the existence of a cohomology class $\varphi \in H^1(N; \mathbb{Z})$ such that $\varphi([\gamma]) \geq 0$ for every closed Reeb orbit γ and $\varphi([e]) = 1$.

We decompose $M = N \cup T^2 \times [1, 2] \cup V$ where V is a solid torus whose meridian is attached to the slope of e . We identify $T^2 \times \{1\}$ with ∂N and $T^2 \times \{2\}$ with ∂V . The region $T^2 \times (1, 2)$ will be called the *no man's land*.²⁴ We choose a contact form α_M on M such that:

1. α_M restricts to α on N , so that, in particular, ∂N is a negative Morse-Bott torus,
2. the closed Reeb orbits in the no man's land have arbitrarily large action and foliate the tori $T^2 \times \{c\}$ for $c \in (1, 2)$,
3. $\alpha_V = \alpha_M|_V$ is nondegenerate in $\text{int}(V)$ and ∂V is a positive Morse-Bott torus,
4. every closed Reeb orbit in $\text{int}(V)$ is transverse to a disc bounded by a meridian,
5. there is an exhaustion of concentric solid tori $V_0 \subset V_1 \subset \dots \subset \text{int}(V)$ such that ∂V_i is linearly foliated by Reeb orbits of irrational slope r_i with $r_i \rightarrow +\infty$ as $i \rightarrow +\infty$ (for some choice of coordinates in which e has slope $+\infty$) and all closed Reeb orbits in $V \setminus V_i$ have slope larger than r_i .

On the Morse-Bott S^1 -family of closed Reeb orbits corresponding to ∂V we choose a Morse function with a unique minimum and a unique maximum point and denote by e' the (elliptic) orbit corresponding to the maximum and h' the (hyperbolic) orbit corresponding to the minimum.

The last condition on α_M implies that the closed Reeb orbits in the no man's land can effectively be ignored in computing $ECH(M)$. In order to prove this rigorously we need a direct limit argument, and therefore we need a family of contact forms α_M for which the closed Reeb orbits in the no man's land have larger and larger action. This direct limit is somewhat involved because it must be repeated at each step of the proof of Theorem 4.4.11, and therefore we prefer to ignore it. For this reason, from now on, every statement in this section will hold after an unexpressed direct limit. See [12, Sections 9.2 and 9.3] for the detailed construction of the contact forms.

After ignoring the closed Reeb orbits in the no man's land, $ECC(M, \alpha_M)$ becomes isomorphic, as a vector space, to $ECC(V, \alpha_V) \otimes ECC(N, \alpha)$, but the differential ∂_M on $ECC(M, \alpha_M)$ is not the usual differential of a tensor product of complexes.

²⁴The name was suggested by a visit to the remains of Berlin's wall.

A filtration

The next step is to introduce a filtration²⁵ \mathcal{F} on $ECC(V, \alpha_V) \otimes ECC(N, \alpha_N)$ to simplify the differential. To construct this filtration, we choose a generator $\eta \in H^1(V; \mathbb{Z})$ which evaluates positively on the closed Reeb orbits in $\text{int}(V)$ and define \mathcal{F}^p as the subspace generated by orbit sets $\gamma \otimes \Gamma$ with $\eta([\gamma]) \leq p$. Note that $\mathcal{F}^p = \{0\}$ for $p < 0$ and \mathcal{F}^0 is generated by orbit sets of the form $\gamma \otimes \Gamma$ where γ contains only orbits in ∂V .

Lemma 4.4.12 ([12, Corollary 9.4.2]). *The differential ∂_M preserves the vector spaces \mathcal{F}^p for all p .*

Sketch of proof. Let u be an embedded holomorphic curve in $\mathbb{R} \times M$ between $\gamma_+ \otimes \Gamma_+$ and $\gamma_- \otimes \Gamma_-$. We denote by $[u] \in H_2(M, \bigcup \gamma_i^+ \cup \bigcup \gamma_j^-)$ the relative homology class determined by the projection of u to M . If γ_+ and γ_- do not contain orbits in ∂V , then it is easy to see that

$$\eta([\gamma_+]) - \eta([\gamma_-]) = [u] \cdot [e'] \geq 0$$

by positivity of the intersections between the image of u and the holomorphic cylinder $\mathbb{R} \times e'$. If γ_+ or γ_- contain orbits in ∂V the proof is more subtle because one has to use positivity of intersection with the nonclosed Reeb orbits on the tori ∂V_i , but it follows the same idea. \square

The next step is to describe the differential induced in the graded complex or, in fancy words, in the zero page of the spectral sequence associated to the filtration. For that we use Morse-Bott techniques, which are justified by the following lemma.

Lemma 4.4.13 (See [12, Corollary 9.5.2]). *A Morse-Bott building u between $\gamma_+ \otimes \Gamma_+$ and $\gamma_- \otimes \Gamma_-$ with $I(u) = 1$ and $\eta(\gamma_+) = \eta(\gamma_-)$ is very nice. Moreover its projection to M is contained either in N or in V or in the no man's land.*

Proof. If $I(u) = 1$ and u is not very nice, it must have two irreducible components joined by a finite length Morse trajectory: the condition $I(u) = 1$ rules out the possibility that u is not very nice because of two irreducible components which are not connectors and are not linked by a Morse trajectory, since those two components could be translated independently in the \mathbb{R} -direction. Then u must have either a positive end at an orbit of ∂N or a negative end at an orbit of ∂V . In either case, positivity of intersection with nearby Reeb orbits implies that u approaches that orbit with a framing different from the framing induced by the Morse-Bott torus, and therefore a topological argument forces $\eta(\gamma_+) > \eta(\gamma_-)$. For the details see Lemma 9.5.1 and Corollary 9.5.2 of [12]. The last claim holds because the tori in the no man's land foliated by Reeb orbits form a barrier for holomorphic curves by the blocking lemma [12, Lemma

²⁵The idea of this filtration was suggested to us by Michael Hutchings.

5.2.3], which is a consequence of positivity of intersection between the projection of u to M and the Reeb vector field. For the details of this last argument see the proof of [12, Lemma 9.5.3]. \square

The holomorphic curves in the symplectisation of the no man's land can be described using a finite energy foliation first constructed by Wendl in [112]; see [12, Section 8.4]: there is a foliation of $\mathbb{R} \times T^2 \times [1, 2]$ by cylinders with positive end at the closed Reeb orbits in $T^2 \times \{2\} = \partial V$ and negative end at the closed Reeb orbits in $T^2 \times \{1\} = \partial N$. After Morse-Bott perturbation, this foliation gives two $I = 1$ holomorphic curves in $\mathbb{R} \times T^2 \times [1, 2]$: one cylinder from e' to h and one cylinder from h' to e . Moreover, the foliation obstructs the existence of any other embedded holomorphic curve in $\mathbb{R} \times T^2 \times [1, 2]$. The same holds for Morse-Bott buildings u with $I(u) = 2$ and constrained to pass through a generic point in $\mathbb{R} \times M$.

Given two orbit sets $\gamma' = \prod \gamma_i^{m'_i}$ and $\gamma = \prod \gamma_i^{m_i}$ (in multiplicative notation), we set $\gamma/\gamma' = \prod \gamma_i^{m_i - m'_i}$ if $m'_i \leq m_i$ for all i ; otherwise we set $\gamma/\gamma' = 0$. We denote $E_0^p = \mathcal{F}^p/\mathcal{F}^{p+1}$; then $E_0 = \bigoplus E_0^p$ is a chain complex with differential ∂_0 induced by ∂_M . The differential ∂_0 respects the direct sum decomposition by construction, and we denote by E_1^p the homology of E_0^p .

As a vector space we can still identify $E_0 \cong ECC(V, \alpha_V) \otimes ECC(N, \alpha)$. More precisely, if we denote the subcomplex of $ECC(V, \alpha_V)$ generated by orbit sets γ such that $\eta([\gamma]) = p$ by $ECC_p(V, \alpha_V)$, then $E_0^p \cong ECC_p(V, \alpha_V) \otimes ECC(N, \alpha)$.

From Lemma 4.4.13 and the description of the $I = 1$ holomorphic curves in the symplectisation of the no man's land, it follows that the differential ∂_0 is

$$\partial_0(\gamma \otimes \mathbf{\Gamma}) = (\partial_V \gamma) \otimes \mathbf{\Gamma} + (\gamma/e') \otimes h\mathbf{\Gamma} + (\gamma/h') \otimes e\mathbf{\Gamma} + \gamma \otimes (\partial_N \mathbf{\Gamma}), \quad (4.9)$$

where ∂_N and ∂_V denote the differential of $ECC(N, \alpha)$ and $ECC(V, \alpha_V)$ respectively. See [12, Lemma 9.5.3].

Computation of E_1

By factoring out the terms h' and h , we can write the differentials ∂_V and ∂_N as:

$$\begin{cases} \partial_V \gamma = \partial_V^b \gamma \\ \partial_V(h'\gamma) = h'\partial_V^b \gamma + \partial'_V(h'\gamma) \end{cases} \quad \begin{cases} \partial_N \mathbf{\Gamma} = \partial_N^b \mathbf{\Gamma} + h\partial'_N \mathbf{\Gamma} \\ \partial_N(h\mathbf{\Gamma}) = h\partial_N^b \mathbf{\Gamma} \end{cases} \quad (4.10)$$

where $\gamma \in ECC^b(V, \alpha_V)$, $\mathbf{\Gamma} \in ECC^b(N, \alpha)$, ∂_V^b and ∂_N^b are the differentials for the chain complexes $ECC^b(V, \alpha_V)$ and $ECC^b(N, \alpha)$ respectively, and the terms $\partial'_V(h'\gamma)$ and $\partial'_N \mathbf{\Gamma}$ do not contain h' .

If we write

$$C_{k,k'}^p = (h')^{k'} ECC_p^b(V, \alpha) \otimes h^k ECC^b(N, \alpha)$$

with $(k, k') \in \{0, 1\}^2$, then we can describe the differential ∂_0 on E_0^p by the following diagram, where each $C_{k,k'}^p$ carries the internal differential $\partial_V^b \otimes 1 + 1 \otimes \partial_N^b$:

$$\begin{array}{ccc}
C_{0,1}^p & \xrightarrow{1 \otimes h \partial_N^b + \cdot / e' \otimes h} & C_{1,1}^p \\
\partial_V^b \otimes 1 + \cdot / h' \otimes e \downarrow & & \downarrow \partial_V^b \otimes 1 + \cdot / h' \otimes e \\
C_{0,0}^p & \xrightarrow{1 \otimes h \partial_N^b + \cdot / e' \otimes h} & C_{1,0}^p
\end{array} \tag{4.11}$$

Thus we can filter each E_0^p by $k' - k$ and the first term of the corresponding spectral sequence (i.e. the homology of the graded complex associated to the filtration) is $ECH_p^b(V, \alpha_V) \otimes ECH^b(N, \alpha)$.

We make a digression into the embedded contact homology of the solid torus.

Lemma 4.4.14 ([12, Lemma 8.1.2(4)]). $ECH^b(V, \alpha_V) \cong \mathbb{F}[e']$.

Sketch of proof. We start by computing $ECH(int(V), \alpha_V)$. We recall the exhaustion $V_0 \subset V_1 \subset \dots \subset int(V)$ by concentric solid tori. Each ∂V_i is linearly foliated by Reeb orbits with irrational slope. Positivity of intersection with the Reeb flow implies that holomorphic curves with ends in V_i are contained in V_i and thus, by [12, Lemma 8.3.1], we have

$$ECH(int(V), \alpha_V) \cong \varinjlim ECH(V_i, \alpha_V|_{V_i}).$$

Since $\alpha_V|_{V_i}$ is irrational, Proposition 4.4.9 applies, and therefore we can compute $ECH(V_i, \alpha_V|_{V_i})$ using a different contact form with a unique simple closed Reeb orbit; see [12, Section 8.2]. For those contact forms the ECH index I can be lifted to an absolute index on closed orbits, which is moreover preserved by continuation maps; see Lemmas 8.2.2 and 8.2.3 in [12]. A direct computation shows that the ECH index of the closed Reeb orbits of the new contact forms on V_i grows with i . In the direct limit only the empty set survives, and thus we have $ECH(int(V), \alpha_V) \cong \mathbb{F}$. See [12, Proposition 8.3.2].

In order to compute $ECH^b(V, \alpha_V)$ we restrict the filtration \mathcal{F} induced by $\eta \in H^1(V; \mathbb{Z})$ to $ECC^b(V, \alpha_V)$. The induced spectral sequence collapses at $E^1 = \mathbb{F}[e'] \otimes ECH(int(V), \alpha_V) \cong \mathbb{F}[e']$. See [12, Section 8.5]. \square

This implies that $ECH^b(V, \alpha_V) \otimes ECH^b(N, \alpha) = 0$ for $p > 0$ and therefore $E_0^p = 0$ for $p > 0$. Thus the spectral sequence induced by \mathcal{F} collapses at the E_1 term and the inclusion $\mathcal{F}^0 \subset ECC(M, \alpha_M)$ induces an isomorphism $E_1^0 = H(\mathcal{F}^0) \cong ECH(M)$.

Now we compute E_1^0 . Given a finite set of simple closed Reeb orbits $\gamma_1, \dots, \gamma_n$ we define $\mathcal{R}[\gamma_1, \dots, \gamma_n]$ as the polynomial algebra generated by those orbits over \mathbb{F} with the relation that $\gamma^2 = 0$ if γ is hyperbolic. Using this notation, $ECC_0(V, \alpha_V) = \mathcal{R}[e', h']$. There are only three holomorphic curves with $I = 1$

between those orbits: two cylinders from e' to h' coming from gradient flow trajectories in the Morse-Bott family corresponding to ∂V and one holomorphic plane positively asymptotic to h . See Propositions 8.4.4 and 8.4.5 of [12] for the construction of this plane. Thus $\partial_V((e')^i) = 0$ and $\partial_V((e')^i h') = (e')^i$, so we can write $E_0^0 \cong \mathcal{R}[e', h'] \otimes ECC(N, \alpha)$ with differential

$$\partial_0(\gamma \otimes \Gamma) = \gamma \otimes (\partial_N \Gamma) + (\gamma/h') \otimes (1 + e)\Gamma + (\gamma/e') \otimes h\Gamma. \quad (4.12)$$

Simple algebra now implies that $E_0^1 \cong ECH(N, \partial N, \alpha)$. In fact $\gamma \otimes \Gamma$ is a cycle only if $\gamma = 1$ and $\partial_N \Gamma = 0$; the third term of Equation (4.12) implies that, if $h\Gamma$ is a cycle, then it is a boundary, and the second term implies that $e\Gamma = \Gamma$ in homology.

Definition of σ

The argument of the previous paragraphs gives a noncanonical isomorphism $ECH(M, \alpha_M) \cong ECH(N, \partial N, \alpha)$. Now we show that this isomorphism is in fact induced by a geometrically meaningful chain map. We define the complex

$$ECC^{\natural}(N, \alpha) = \mathcal{R}[h'] \otimes ECC^b(N, \alpha)$$

with differential

$$\partial^{\natural}(\gamma \otimes \Gamma) = \gamma \otimes \partial_N^b(\Gamma) + \gamma/h' \otimes (1 + e)\Gamma. \quad (4.13)$$

It is easy to show that $ECH^{\natural}(N, \alpha) \cong ECH(N, \partial N, \alpha)$.

We define

$$\sigma(\gamma \otimes \Gamma) = \sum_{i=0}^{\infty} (e')^i \gamma \otimes (\partial_N')^i \Gamma. \quad (4.14)$$

The sum is well defined because $(\partial_N')^{k+1}(\Gamma) = 0$ if $\varphi([\Gamma]) = k$, where φ is a class in $H^1(N; \mathbb{Z})$ such that $\varphi([e]) = 1$.

Since $\gamma = (h')^j$ for $j = 0, 1$, the image of σ is contained in \mathcal{F}^0 , which is the first nonzero group of the filtration, and therefore to show that σ is a chain map it is enough to verify that $\sigma \circ \partial^{\natural} = \partial_0 \circ \sigma$. This is an easy verification using Equation (4.9) and the fact that ∂_N' commutes with ∂_N^b and the multiplication by e . Finally one can prove without much effort by algebraic considerations similar to those of the previous paragraph that the map σ induces an isomorphism in homology.

The U map and the hat version

We recall that the U map in $ECC(M, \alpha_M)$ counts $I = 2$ holomorphic curves in $\mathbb{R} \times M$ passing through a generic base point $\mathbf{z} \in \mathbb{R} \times M$. In order to simplify the computation, we put the base point in the symplectisation of the no man's land $\mathbb{R} \times T^2 \times (1, 2)$. The following lemma is proved by the same techniques we used to study the differential.

Lemma 4.4.15 (See [12, Lemma 9.9.3]). *The map U preserves the filtration \mathcal{F} . In the lowest filtration level \mathcal{F}^0 , it is given by*

$$U(\gamma \otimes \mathbf{\Gamma}) = \gamma/e' \otimes \mathbf{\Gamma}. \quad (4.15)$$

The unique holomorphic curve contributing to U in the lowest filtration level is a cylinder from e' to e belonging to the finite energy foliation of $\mathbb{R} \times T^2 \times [1, 2]$ described in [12, Section 8.4] which was already used to understand the differential ∂_0 .

On the other hand, we define the map $U^\natural : ECC^\natural(N, \alpha) \rightarrow ECC^\natural(N, \alpha)$ by

$$U^\natural(\gamma \otimes \mathbf{\Gamma}) = \gamma \otimes \partial'_N \mathbf{\Gamma}. \quad (4.16)$$

By comparing Equation (4.16) with Equations (4.13), (4.14) and (4.15), we obtain that U^\natural is a chain map and that the diagram

$$\begin{array}{ccc} ECC^\natural(N, \alpha) & \xrightarrow{U^\natural} & ECC^\natural(N, \alpha) \\ \sigma \downarrow & & \sigma \downarrow \\ ECC(M, \alpha_M) & \xrightarrow{U} & ECC(M, \alpha_M) \end{array}$$

commutes. The map U^\natural corresponds to U_{rel} under the isomorphism $ECH^\natural(N, \alpha) \cong ECH(N, \partial N, \alpha)$, and therefore we have established part of Theorem 4.4.11.

We also define the chain complex

$$\widehat{ECC}^\natural(N, \alpha) = \mathcal{R}[h'] \otimes ECC(N, \alpha)$$

with differential

$$\widehat{\partial}^\natural(\gamma \otimes \mathbf{\Gamma}) = \gamma \otimes \partial_N \mathbf{\Gamma} + \gamma/h' \otimes (1 + e)\mathbf{\Gamma}.$$

The decomposition of the differential ∂_N described in Equation (4.10) implies that $\widehat{ECC}^\natural(N, \alpha)$ is the cone of the map U^\natural . Moreover one can easily prove that $\widehat{ECH}^\natural(N, \alpha) \cong \widehat{ECH}(N, \partial N, \alpha)$, and therefore the remaining part of Theorem 4.4.11 follows from the naturality of the mapping cone construction.

4.4.5 Sutured embedded contact homology

Sutured embedded contact homology is a version of embedded contact homology for balanced sutured manifolds which was defined in [16]. In this subsection we relate some sutured embedded contact homology groups to some versions of embedded contact homology introduced in Subsection 4.4.3.

Definition 4.4.16 (See [16, Definition 2.8]). A contact form α is *adapted* to the balanced sutured manifold (M, γ) if $\alpha|_{R_{\pm}(\gamma)}$ are Liouville forms on $R_{\pm}(\gamma)$ and the Reeb vector field is transverse and outward pointing on $R_+(\gamma)$, transverse and inward pointing at $R_-(\gamma)$ and tangent to γ , so that γ is foliated by Reeb trajectories going from $R_-(\gamma)$ to $R_+(\gamma)$. Most often we will write (M, Γ) for (M, γ) , where Γ is the suture.

The simplest example of a sutured manifold with an adapted contact form is the following: we take a compact, oriented surface with boundary P and form the product sutured manifold (M, γ) with $M = P \times [-1, 1]$ and $\gamma = \partial P \times [-1, 1]$. Then the contact form is $\alpha = \lambda + dt$, where λ is a Liouville form on P , is adapted to (M, γ) . However many more interesting examples exist: in fact, contact sutured manifolds are a fairly general concept, as the following proposition shows.

Proposition 4.4.17 (See [16, Lemma 4.1]). *Let (M, ξ) be a contact manifold with convex boundary and no closed connected component, and let Γ be the dividing set of ∂M . Then ξ admits a contact form which is adapted to the balanced sutured manifold²⁶ (M, Γ) .*

The interest of sutured contact manifolds is that they form a fairly large class of contact manifolds for which SFT and ECH compactness hold: see Corollaries 5.19 and 5.21 of [16]. In [16] we considered sutured contact manifolds of any dimension, and that level of generality introduced extra complications in the proof of compactness. In dimension three, however, the story is fairly simple: all we need to show is that a J -holomorphic curve in $\mathbb{R} \times M$ which is asymptotic to closed Reeb orbits of α cannot touch $\mathbb{R} \times \partial M$ if J belongs to a suitable class of almost complex structures. Roughly speaking, we define a function t on a neighbourhood of ∂M by integrating the Reeb vector field, and a function τ in a neighbourhood of $N(\Gamma) \cong (-\epsilon, 0] \times \Gamma \times [0, 1]$ in M such that, in that neighbourhood, we can write $\alpha = dt + e^\tau d\theta$ with θ a coordinate on Γ and τ is the coordinate in $(-\epsilon, 0]$. We say that an almost complex structure J on $\mathbb{R} \times M$ is *tailored* to (M, Γ, α) if it is compatible with α and moreover t is harmonic and τ is subharmonic with respect to the Laplacian induced by J ; see Sections 3.1, 5.2 and 5.3 of [16]. Thus, if u is a J -holomorphic curve which is asymptotic to closed Reeb orbits, the maximum principle applied to $t \circ u$ and $\tau \circ u$ is enough to show that u cannot intersect the region where t and τ are defined. It is easy to see that the space of tailored almost complex structures is nonempty and contractible in dimension three.

All other aspects of the theory of J -holomorphic curves (i.e. regularity, Fredholm theory, transversality, gluing, etc.) are semi-local in nature, and therefore do not change if the ambient manifold is not closed. Thus, we can define the *sutured embedded contact homology* complex $ECC(M, \Gamma, \alpha)$ as the vector spaces over \mathbb{F} generated by orbit sets in M with differential counting J -holomorphic

²⁶ (M, Γ) is a balanced sutured manifold by [45].

curves in $\mathbb{R} \times M$ with ECH index $I = 1$ for a tailored almost complex structure J . These complexes were defined in [16] and were inspired by sutured Floer homology defined by Juhász in the context of Heegaard Floer homology in [69]. We conjectured the following.

Conjecture 4.4.18 ([16, Conjecture 1.5]). *Let (M, Γ, α) be a sutured contact manifold. Then there is an isomorphism*

$$ECH(M, \Gamma, \alpha) \cong SFH(-M, -\Gamma),$$

which moreover respects the decomposition into first homology classes on the left hand side and relative $Spin^c$ structures on the right hand side.

The proof of this conjecture is currently a work in progress in collaboration with Colin, Honda and Spano. Evidence came from the proof of gluing maps which are formally analogous to Juhász's map for sutured decompositions from [70] and Honda, Kazez and Matić's map for gluing along convex surfaces from [56]: see Theorems 1.9 and 1.10 in [16].

The sutured embedded contact homology groups are independent of the contact form and the almost complex structure in the following sense.

Theorem 4.4.19 ([12, Theorem 10.2.2]). *Let α_1 and α_2 be contact forms adapted to the balanced sutured manifold (M, Γ) and let J_1 and J_2 be almost complex structures on $\mathbb{R} \times M$ such that J_i is tailored to (M, Γ, α_i) for $i = 1, 2$. If $\xi_1 = \ker \alpha_1$ and $\xi_2 = \ker \alpha_2$ are isotopic through contact structures making ∂M convex with dividing set Γ , then*

$$ECH(M, \Gamma, \alpha_1) \cong ECH(M, \Gamma, \alpha_2),$$

where the first group is defined using J_1 and the second using J_2 . Moreover this isomorphism preserves the decomposition of the sutured embedded contact homology groups as direct sums of subgroups indexed by homology classes in $H_1(M)$.

The proof is similar to the proof of Proposition 4.4.9. This result has been proved independently, but with similar techniques, by Kutluhan, Sivek and Taubes [79], who also prove naturality of the isomorphism. In light of Conjecture 4.4.18 we expect that the sutured contact homology groups should be independent also of the contact structure, but at the moment we are not able to find a direct proof of this more general invariance.

Two more basic but important examples of sutured manifolds are the following:

- given a closed three-manifold M and an embedded codimension zero ball $B \subset M$, we define the balanced sutured manifold $(M(1), \Gamma_1)$, where $M(1) = M \setminus \text{int}(B)$ and Γ_1 is a connected curve in $\partial M(1)$;

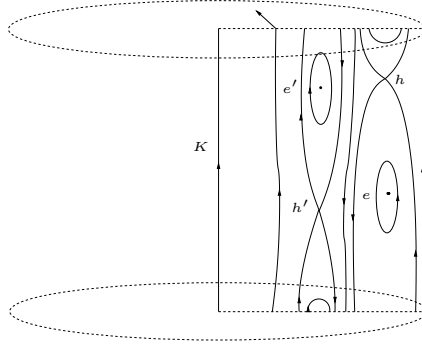

Figure 4.3: The first return map of the Reeb vector field of α_M on a longitudinal section of a neighbourhood of K . The top and the bottom are identified.

- given a closed three-manifold M and knot $K \subset M$, we define a balanced sutured manifold $(M(K), \Gamma_K)$, where $M(K) = M \setminus \text{Nbd}(K)$ is the complement of an open tubular neighbourhood of K and Γ_K consists of two parallel copies of the meridian of K with opposite orientations.

Sutured embedded contact homology for these two sutured manifolds is related to the embedded contact homology groups defined in subsection 4.4.3 as follows.

Theorem 4.4.20 ([12, Theorem 10.3.1 and Theorem 10.3.2]). *Let M be a closed three-manifold, $K \subset M$ a knot and N the complement of an open tubular neighbourhood of K in M . Then there exist a contact form on N as in Subsection 4.4.3 and adapted contact forms α_1 on $(M(1), \Gamma_1)$ and α_K on $(M(K), \Gamma_K)$ such that*

$$\begin{aligned} ECH(M(1), \Gamma_1, \alpha_1) &\cong \widehat{ECH}(N, \partial N, \alpha) \quad \text{and} \\ ECH(M(K), \Gamma_K, \alpha_K) &\cong ECH^\natural(N, \alpha). \end{aligned}$$

Sketch of proof. Let α_M be a contact form on M as in Subsection 4.4.4. The first return map of the Reeb vector field of α_M in a neighbourhood of K containing ∂N and after the Morse-Bott perturbation is depicted in Figure 4.3. The sutured manifold $(M(1), \Gamma_1)$ is identified to the subset of M described in the left side of Figure 4.4. The adapted contact forms α_1 is the restrictions of α_M to $M(1)$. However, the contact form α'_K obtained by restricting α_M to $M(K)$ is not adapted to the suture because its restriction to $R_\pm(\Gamma_K)$ is not a Liouville form. This can be seen from the fact that the contact structure is negatively transverse to the component of $\partial R_\pm(\Gamma_K)$ which is closer to K . The issue can be corrected by adding a layer to that component in which the Reeb vector field remains constant and the contact structure rotates until it satisfies the sutured condition. The new sutured manifold is diffeomorphic to $(M(K), \Gamma_K)$ and the contact form α_K we obtain is adapted to $(M(K), \Gamma_K)$.

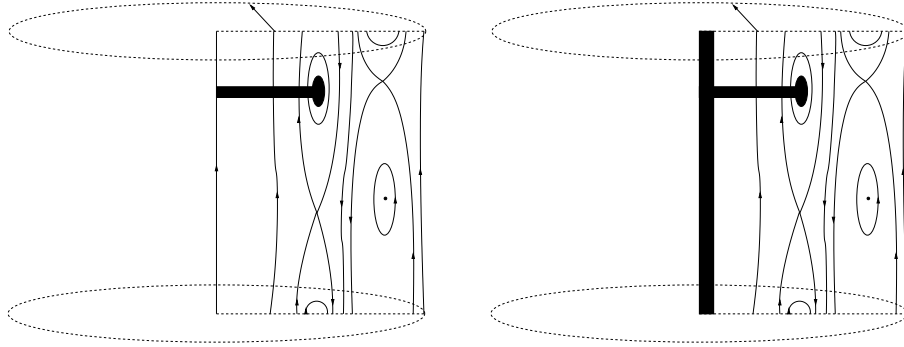

Figure 4.4: The ball B and the neighbourhood $Nbd(K)$ are obtained by rotating the shaded regions on the left and on the right, respectively, around the vertical axis. The top and the bottom are identified.

Both $ECC(M(1), \Gamma_1, \alpha_1)$ and $ECC(M(K), \Gamma_K, \alpha_K)$ are generated by orbit sets containing closed Reeb orbits in N and h' ; moreover the holomorphic plane in $\mathbb{R} \times M$ which is positively asymptotic to h' does not contribute to the differential of $ECC(M(K), \Gamma_K, \alpha_K)$. At this point, the result follows by some algebra like in the proof of Theorem 4.4.11, but easier. \square

From Theorem 4.4.11 we deduce the following corollary.

Corollary 4.4.21. $ECH(M(1), \Gamma_1, \alpha_1) \cong \widehat{ECH}(M, \alpha_M)$.

Combining Conjecture 4.4.18 with Theorem 4.4.18 and the relation between sutured Floer homology and knot Floer homology, we obtain the following conjecture.

Conjecture 4.4.22. *If $K \subset M$ is a null-homologous knot of genus g , N is the complement of an open tubular neighbourhood of K and α is a contact form on N for which ∂N is a negative Morse-Bott torus foliated by meridians of K , then*

$$ECH_i^\sharp(N, \alpha) \cong \widehat{HFK}(-M, -K, i - g),$$

where $ECH_i^\sharp(N, \alpha)$ denotes the homology of the subcomplex of $ECC^\sharp(N, \alpha)$ generated by orbit sets in N with total linking number²⁷ i with K .

4.4.6 Periodic Floer homology and open books

We recall from Giroux [49] that a contact form is supported by an open book decomposition if its Reeb vector field is tangent to the binding and positively

²⁷The linking number and the Alexander grading in knot Floer homology depend on a choice of Seifert surface if $H_2(M; \mathbb{Z}) \neq 0$. Here we assume that we have made the same choice in both cases.

transverse to the interior of the pages. In the same article he also announced an equivalence between contact structures up to isotopy and open book decompositions up to positive stabilisation [49], but we will only need the easy part of the equivalence for our purposes; namely the existence of contact forms supported by open book decomposition and the isotopy between contact structures supported by open book decompositions related by positive stabilisations.

Let (S, \mathfrak{h}) be an abstract open book decomposition for M . We assume, without loss of generality, that ∂S is connected, and identify the mapping torus of \mathfrak{h} , denoted by N , with the complement of a tubular neighbourhood of the binding. On \mathfrak{h} we assume the following:

- $\mathfrak{h}^*\beta - \beta$ is exact for some Liouville form β on S , and
- $\mathfrak{h}(y, \theta) = (y, \theta - y)$ for coordinates $(y, \theta) \in (-\varepsilon, 0] \times \mathbb{R}/\mathbb{Z}$ in a collar of ∂S .

By a Moser's trick argument one can always find a representative of the monodromy satisfying the conditions above (see [12, Lemma 9.3.2]) and, by a refinement of Thurston and Winkelnkemper's construction from [110], one can construct a contact form α on M which is supported by the open book decomposition (S, \mathfrak{h}) , and such that the first return map of the Reeb flow in N is \mathfrak{h} and ∂N is a negative Morse-Bott torus; see [12, Lemma 9.3.3] and [14, Lemma 2.12]. Thus the Reeb flow of α on N satisfies the conditions of Subsections 4.4.3 and 4.4.4 permitting to define $ECH(N, \partial N, \alpha)$ and prove the isomorphism with $ECH(M, \alpha)$.

We define

$$ECH_i(N, \alpha) = \bigoplus_{a \cdot [S] = i} ECH_a(N, \alpha),$$

where $a \in H_1(N)$ and $[S] \in H_2(N, \partial N)$ is the relative homology class of a page of the open book decomposition. Thus, by Lemma 4.4.10,

$$\widehat{ECH}(N, \partial N, \alpha) = \varinjlim ECH_i(N, \alpha).$$

In the definition of the isomorphism between $\widehat{HF}(-M)$ and $\widehat{ECH}(M)$ it will be useful to pass to periodic Floer homology groups.

There is a family of stable Hamiltonian structure $(\alpha_\varsigma, \omega_\varsigma)_{\varsigma \in [0,1]}$ such that $\omega_\varsigma = d\alpha_\varsigma$ for $\varsigma \in (0, 1]$ (i.e. α_ς is a contact form for $\varsigma \neq 0$), $\alpha_1 = \alpha$ and (α_0, ω_0) is the stable Hamiltonian structure induced by the fibration $\pi: N \rightarrow S^1$. See [14, Section 3.1]. Let J_ς be a smooth family of almost complex structures on $\mathbb{R} \times N$ compatible with $(\alpha_\varsigma, \omega_\varsigma)$.

The *Periodic Floer homology* complexes $PFC_i(N, \alpha_0, \omega)$ are defined in the same way as the embedded contact homology complexes $ECC_i(N, \alpha)$: the different names have only a historical motivation. We can also define all decorated version of periodic Floer homology as in Subsection 4.4.3. By comparing regular J_0 -holomorphic curves with J_ς -holomorphic curves with $\varsigma > 0$ sufficiently small, we obtain the following result.

Lemma 4.4.23 (See [14, Theorem 3.6.1]). *For every $i \in \mathbb{N}$ there exists $\varsigma_i \in (0, 1]$ such that, for all $\varsigma \in (0, \varsigma_i]$, there is an isomorphism of chain complexes*

$$PFC_i(N, \alpha_0, \omega_0) \cong ECC_i(N, \alpha_\varsigma).$$

This is not yet enough for taking direct limits because ς_i becomes smaller as i increases and might tend to zero.²⁸ However, arguing with more care, we can prove the following.

Lemma 4.4.24. *For α and (α_0, ω_0) as above, there is an isomorphism*

$$\varinjlim PFH_i(N, \alpha_0, \omega_0) = \widehat{PFH}(N, \partial N, \alpha_0, \omega_0) \cong \widehat{ECH}(N, \partial N, \alpha).$$

Proof. We need to define continuation maps $ECC_i(N, \alpha) \rightarrow ECC_i(N, \alpha_{\varsigma_i})$ for every $i \in \mathbb{N}$ such that the diagrams

$$\begin{array}{ccccc} ECC_i(N, \alpha) & \longrightarrow & ECC_i(N, \alpha_{\varsigma_i}) & \xlongequal{\quad} & PFC_i(N, \alpha_0, \omega_0) \\ \cdot e \downarrow & & & & \cdot e \downarrow \\ ECC_{i+1}(N, \alpha) & \longrightarrow & ECC_{i+1}(N, \alpha_{\varsigma_{i+1}}) & \xlongequal{\quad} & PFC_i(N, \alpha_0, \omega_0) \end{array}$$

commutes. To define the continuation maps $ECC_i(N, \alpha) \rightarrow ECC_i(N, \alpha_{\varsigma_i})$, we slightly enlarge N to N' so that $\partial N'$ is foliated by Reeb orbits of irrational slope and no new closed Reeb orbit intersecting a page less than $i + 2$ times is created, and invoke Proposition 4.4.9. The continuation maps are supported²⁹ on holomorphic curves which are contained in $\mathbb{R} \times M$ endowed with a symplectic form which interpolates between α and α_{ς_i} . By the trapping lemma [12, Lemma 5.3.2], curves with a positive end at e must contain a trivial cylinder over e , and therefore the commutativity of the diagram follows. \square

4.5 The open-closed maps Φ and Φ^+

In this section we define maps from Heegaard Floer homology to embedded contact homology. As it often happens in symplectic geometry, these maps will be defined by counting holomorphic curves in symplectic cobordisms. Here the symplectic cobordisms will come from an open book decomposition (S, \mathfrak{h}) of M .

²⁸This issue was pointed out to us by Thomas Brown.

²⁹See [12, Theorem 3.1.2] for the definition of supported and an overview on continuation maps in ECH and [67] for the full story.

4.5.1 The maps Φ and $\widehat{\Phi}_*$

Let B_+ be the unit disc with one puncture in the interior and one puncture on the boundary, which we identify biholomorphically with the subset of the cylinder $\mathbb{R} \times \mathbb{R}/2\mathbb{Z}$ obtained by rounding the corners of $\mathbb{R} \times \mathbb{R}/2\mathbb{Z} \setminus (2, +\infty) \times (1, 2)$. We define a fibration

$$\pi_{W_+}: W_+ \rightarrow B_+$$

with fibre S and monodromy h , and equip the total space with the symplectic form $\Omega_+ = ds \wedge dt + \omega$, where (s, t) are coordinates on $B_+ \subset \mathbb{R} \times \mathbb{R}/2\mathbb{Z}$ and $\omega = d\beta$ is an area form on S which is preserved by h . We can view (W_+, Ω_+) as a symplectic cobordism (with boundary) between $[0, 1] \times S$ and N . We refer to [14, Section 5] for more details about this construction.

Let $\mathbf{a} = \{a_1, \dots, a_{2g}\}$ be a basis of arcs of S . We define a Lagrangian submanifold $L_{\mathbf{a}} \subset \partial W$ as the trace of the parallel transport of $\{3\} \times \{1\} \times \mathbf{a}$ along ∂B_+ with respect to the symplectic connection defined as the Ω_+ -orthogonal to the tangent spaces of the fibres. Then,

$$\begin{aligned} L_{\mathbf{a}} \cap [3, +\infty) \times \{1\} \times S &= [3, +\infty) \times \{1\} \times \mathbf{a} \\ L_{\mathbf{a}} \cap [3, +\infty) \times \{0\} \times S &= [3, +\infty) \times \{0\} \times h(\mathbf{a}). \end{aligned}$$

In the following $\widehat{\mathcal{O}}_k$ will denote the set of orbit sets in N with total intersection number k with a fibre. We fix an almost complex structure J_+ on W_+ which is compatible with Ω_+ and with the stable Hamiltonian structures at the ends. Given a Heegaard Floer generator $\mathbf{y} \in \mathcal{S}_{\mathbf{a}, h(\mathbf{a})}$ and a periodic Floer homology generator $\gamma \in \widehat{\mathcal{O}}_{2g}$, we denote by $\mathcal{M}_{W_+}(\mathbf{y}, \gamma)$ the moduli space of J_+ -holomorphic curves in W_+ with boundary on $L_{\mathbf{a}}$ which are positively asymptotic to $[0, 1] \times \mathbf{y}$ and negatively asymptotic to γ . Holomorphic curves in $\mathcal{M}_{W_+}(\mathbf{y}, \gamma)$ are somewhere injective because distinct connected components of the boundary are on distinct connected components of $L_{\mathbf{a}}$. Thus, for generic J_+ , the moduli spaces $\mathcal{M}_{W_+}(\mathbf{y}, \gamma)$ are (disjoint unions of) smooth manifolds of the dimension predicted by the Fredholm index.

The ECH-type index I for J_+ -holomorphic curves in $\mathcal{M}_{W_+}(\mathbf{y}, \gamma)$ is defined in [14, Definition 5.6.5]. By the index inequality [14, Theorem 5.6.9], J_+ -holomorphic curves u with $I(u) = 0$ are embedded and have Fredholm index $\text{Ind}(u) = 0$, and therefore are isolated. We define

$$\overline{\Phi}: \overline{CF}(S, \mathbf{a}, h(\mathbf{a})) \rightarrow PFC_{2g}(N, \alpha_0, \omega)$$

such that, on each $\mathbf{y} \in \mathcal{S}_{\mathbf{a}, h(\mathbf{a})}$, it is given by

$$\overline{\Phi}(\mathbf{y}) = \sum_{\gamma \in \widehat{\mathcal{O}}_{2g}} \# \mathcal{M}^{I=0}(\mathbf{y}, \gamma) \gamma. \quad (4.17)$$

Compactness and gluing for holomorphic curves in Heegaard Floer homology and embedded contact homology extend to holomorphic curves in W_+ . Therefore the usual argument on the ends of one-dimensional moduli spaces proves that $\overline{\Phi}$ is a chain map; see [14, Proposition 6.2.2]

Lemma 4.5.1 ([14, Theorem 6.2.4]). *The map $\overline{\Phi}$ induces a chain map*

$$\Phi: \widehat{CF}(S, \mathbf{a}, h(\mathbf{a})) \rightarrow PFC_{2g}(N, \alpha_0, \omega)$$

and moreover $\Phi(\mathbf{x}) = e^{2g}$, where \mathbf{x} represents the contact class.

Sketch of proof. The statement follows from the following fact, proved in [14, Lemma 6.2.3]: a J_+ -holomorphic curve in W_+ with boundary on $L_{\mathbf{a}}$ which is positively asymptotic to a chord over an intersection point x on ∂S (i.e. $x = x_i$ or $x = x'_i$ for some i) has an irreducible component consisting of a trivial section $B_+ \times \{x\}$ followed by a gradient flow trajectory connecting the orbit over x to e in the Morse-Bott family associated to ∂N . In fact it follows from topological properties of holomorphic curves that a nonconstant positive end at x cannot be contained in W_+ . \square

Finally we define the map $\widehat{\Phi}_*: \widehat{HF}(-M) \rightarrow \widehat{ECH}(M)$ of Theorem 4.1.1 as the composition of $\Phi_*: \widehat{HF}(S, \mathbf{a}, h(\mathbf{a})) \rightarrow ECH_{2g}(N, \alpha_0, \omega)$ with the inclusion

$$PFC_{2g}(N, \alpha_0, \omega) \rightarrow \widehat{PFC}(N, \partial N, \alpha_0, \omega) \cong \widehat{ECH}(N, \partial N, \alpha)$$

and the isomorphism $\widehat{\sigma}_*: \widehat{ECH}(N, \partial N, \alpha) \rightarrow \widehat{ECH}(M)$ of Theorem 4.4.11.

Remark 4.5.2. We could have defined the map Φ using the contact form α instead of the stable Hamiltonian structure (α_0, ω) at the negative end of W_+ . However, working with the stable Hamiltonian structure induced by the fibration will be useful in the construction of the inverse map Ψ in Section 4.6.

4.5.2 The map Φ^+

The map Φ^+ will be defined by counting holomorphic curves in a symplectic cobordism with boundary (X_+, Ω_{X_+}) from $[0, 1] \times \Sigma$ to M . The symplectic form Ω_{X_+} will not be exact, and therefore the count will require some extra care.

The symplectic cobordism (X_+, Ω_{X_+})

We describe a simplified construction of (X_+, Ω_{X_+}) and refer the reader to [13, Section 4] for the actual details, with the warning that the notations will not correspond exactly.

Let $(\Sigma, \alpha, \beta, z)$ be the pointed Heegaard diagram for $-M$ associated to the open book decomposition (S, \hat{h}) as in Subsection 4.3.3.³⁰ In particular $\Sigma = S_0 \cup -S_1$. For technical reasons we need to assume that S has genus at least two. We also fix an area form ω^+ on Σ , whose properties will be specified in the construction of X_+ .

We decompose $M = N \cup T^2 \times [1, 2] \times V$ as in Subsection 4.4.4 and choose a contact form λ on M which is supported by the open book decomposition (S, \hat{h}) and moreover satisfies the following properties:

1. $\lambda|_N = \alpha$ (in particular ∂N is a negative Morse-Bott torus),
2. ∂V is a positive Morse-Bott torus,
3. Reeb orbits in $\text{int}(V)$ and in the no man's land $T^2 \times (1, 2)$ are long³¹, and
4. $(\alpha, d\alpha)$ is close to the stable Hamiltonian structure (α_0, ω) induced by the fibration $N \rightarrow S^1$ with fibre S , so that $ECC_{2g}(N, \alpha)$ is isomorphic to $PFC_{2g}(N, \alpha_0, \omega)$.

At least at a first approximation, the symplectic cobordism (X_+, Ω_{X_+}) will satisfy the following properties:

1. the positive end is

$$X_+^> = [3, +\infty) \times [0, 1] \times \Sigma, \quad \Omega_{X_+}|_{X_+^>} = ds \wedge dt + \omega^+;$$

2. the negative end is

$$X_+^< = (-\infty, -1] \times M, \quad \Omega_{X_+}|_{X_+^<} = d(e^s \lambda);$$

3. there is a symplectic surface $S_z \subset X_+$ such that

$$S_z \cap X_+^> = [3, +\infty) \times [0, 1] \times \{z\} \quad \text{and} \quad S_z \cap X_+^< = \emptyset;$$

4. $\Omega_{X_+}|_{X_+ \setminus S_z} = d\Theta$ for some one-form Θ such that $\Theta|_{X_+^<} = e^s \lambda$;

5. there is a Legendrian submanifold $L_\alpha \subset \partial X_+$ such that

$$X_+^> \cap L_\alpha = ([3, +\infty) \times \{0\} \times \beta) \cup ([3, +\infty) \times \{1\} \times \alpha)$$

and Θ is exact on L_α ; and

6. there is an embedding of W_+ into X_+ such that $W_+ \cap S_z = \emptyset$,

$$X_+^> \cap W_+ = [3, +\infty) \times [0, 1] \times S_0, \quad X_+^< \cap W_+ = (-\infty, -1) \times N,$$

and the restriction of Ω_{X_+} to W_+ is close to Ω_+ (see the proof of Lemma 4.5.5).

³⁰What we call Σ here was called $-\Sigma$ there.

³¹What "long" means will be made clear in Lemma 4.5.5.

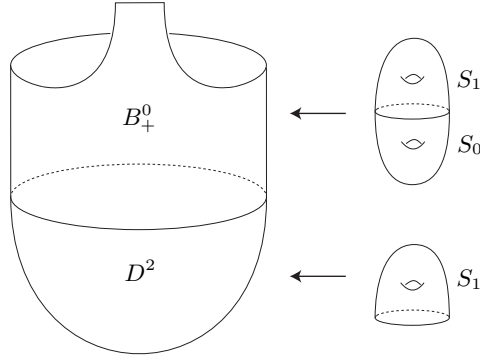

Figure 4.5: Schematic diagram for $X_+^0 \cup X_+^1$ which indicates the fibres over each subsurface.

We refer to [13, Lemma 4.1.1] for a more precise description of (X_+, Ω_{X_+}) . We will give here only a sketch of the construction; the details, which are quite delicate, can be found in [13, Section 4.1].

We identify $S_0 \cong S$ and extend $\hbar: S_0 \rightarrow S_0$ to a diffeomorphism $\hbar^+: \Sigma \rightarrow \Sigma$ which, on S_1 , restricts to a perturbation of the identity by a small Hamiltonian isotopy. We require that $\beta = \hbar^+(\alpha)$. Let $B_+^0 = B_+ \cap [0, +\infty) \times S^1$; i.e. we cut the negative end out of B_+ . We define X_+^0 as the bundle over B_+^0 with fibre Σ and monodromy \hbar^+ . If ω^+ is an area form on Σ preserved by \hbar^+ , then we define $\Omega_{X_+^0} = ds \wedge dt + \omega^+$. The component of the boundary of X_+^0 over $\{0\} \times S^1$ is a three-manifold N^+ obtained as mapping torus of (Σ, \hbar^+) . It contains the mapping torus N of (S, \hbar) as a closed submanifold of codimension zero.

We define $X_+^1 = D^2 \times S_1$ and $\Omega_{X_+^1} = \omega_{D^2} + \omega^+|_{S_1}$ where, of course, ω_{D^2} is the standard symplectic form on D^2 . Then we glue X_+^0 and X_+^1 by identifying $\partial D^2 \times S_1 \subset \partial X_+^1$ with $N^+ \setminus \text{int}(N)$, which is the mapping torus of $(S_1, \hbar^+|_{S_1})$. We can glue the symplectic forms $\Omega_{X_+^0}$ and $\Omega_{X_+^1}$ because $\hbar^+|_{S_1}$ is Hamiltonian isotopic to the identity. The gluing of X_+^0 and X_+^1 is schematically depicted in Figure 4.5. Thus $X_+^0 \cup X_+^1$ is a manifold with boundary and (concave) corners and the compact boundary component of $X_+^0 \cup X_+^1$ is homeomorphic to M . We smooth the corner and modify the symplectic form near the compact boundary component so that, in a collar, it looks like a piece of the symplectisation of (M, λ) . Finally we obtain (X_+, Ω_{X_+}) by completing $X_+^0 \cup X_+^1$ with the negative half-symplectisation $((-\infty, 0] \times M, d(e^r \lambda))$ of (M, λ) .

We assume that the base point $z \in S_1$ is a fixed point for \hbar^+ ; then we define the symplectic surface

$$S_z = (B_+^0 \cup D^2) \times \{z\}.$$

Finally, we define a Lagrangian submanifold $L_\alpha \subset \partial X_+$ such that

$$X_+^\geq \cap L_\alpha = ([3, +\infty) \times \{0\} \times \beta) \cup ([3, +\infty) \times \{1\} \times \alpha).$$

Note that $\partial X_+ \subset X_+^0$, which is the portion of X_+ which has the structure of a symplectic surface bundle, and therefore has a symplectic connection. As it was the case for $L_{\mathbf{a}} \subset \partial W_+$, we define L_{α} as the trace of the parallel transport of $\{3\} \times \{1\} \times \alpha$ along ∂B_+ with respect to symplectic connection.

Definition of Φ^+

We fix a generic almost complex structure J^+ on X_+ which is compatible with Ω_{X_+} and the stable Hamiltonian structures at the ends, and makes S_z holomorphic. Given a $2g$ -tuple of intersection points $\mathbf{y} \in \mathcal{S}_{\alpha, \beta}$ and an orbit set $\gamma \in \mathcal{O}$ (i.e. built from simple closed Reeb orbits in M) we denote by $\mathcal{M}_{X_+}(\mathbf{y}, \gamma)$ the moduli space of J^+ -holomorphic curves in X_+ with boundary on L_{α} which are positively asymptotic to $[0, 1] \times \mathbf{y}$ and negative asymptotic to γ . To a curve $u \in \mathcal{M}_{X_+}(\mathbf{y}, \gamma)$ we associate an ECH-type index $I(u)$ and the intersection number $\mathcal{F}(u)$ between the image of u and the surface S_z . By positivity of intersection, $\mathcal{F}(u) \geq 0$.

We define the map $\Phi^+ : CF^+(\Sigma, \alpha, \beta, z) \rightarrow ECC(M, \lambda)$ as

$$\Phi^+([\mathbf{y}, i]) = \sum_{\gamma \in \mathcal{O}} \sum_{j=0}^i \# \mathcal{M}_{X_+}^{I=0, \mathcal{F}=j}(\mathbf{y}, \gamma) \gamma. \tag{4.18}$$

Theorem 4.5.3. Φ^+ is a well defined chain map.

This follows from the usual analysis of moduli spaces. However, the symplectic form Ω_{X_+} is not exact, and therefore some extra care is needed. For example, fixing the intersection number \mathcal{F} is an important ingredient for proving compactness of the moduli spaces. Moreover, J^+ -holomorphic curves with no positive ends can exist, and we have to exclude them from the count. This is done by showing that they have large ECH-type index; see Lemmas 5.6.2 and 5.6.3 of [13]. The assumption on the genus of S is used here.

We need to show that the maps $\widehat{\Phi}_*$ and Φ^* fit into the commutative diagram (4.1). In [13, Section 6] this is done by comparing the mapping cones of U in Heegaard-Floer homology and embedded contact homology. For simplicity we prefer to ignore algebraic complications and illustrate only the geometric ideas of [13, Section 6]. Thus, instead to work with cones, we will sketch only the proofs of commutativity of the two squares displayed in (4.1). The next theorem shows commutativity of the right-hand square.

Theorem 4.5.4 ([13, Theorem 5.9.1]). *The map Φ^+ commutes up to homotopy with the maps U on Heegaard Floer homology and embedded contact homology.*

Proof. The maps U are defined by counting $I = 2$ holomorphic curves passing through a generic point: in embedded contact homology by definition and in Heegaard Floer homology by Theorem 4.3.2. We define a chain homotopy

between $\Phi^+ \circ U$ and $U \circ \Phi^+$ by moving a base point from the positive end of X_+ to the negative end, and counting $I = 1$ holomorphic curves in X_+ passing through the moving point at some isolated instant. \square

Now we prove commutativity of the left-hand square.

Lemma 4.5.5 ([13, Lemmas 5.8.1 and 5.8.2]). *If $\mathbf{y} \in \mathcal{S}_{\mathbf{a}, \hbar(\mathbf{a})}$ and $u \in \mathcal{M}_{X_+}^{\mathcal{F}=0}(\mathbf{y}, \gamma)$, then $\gamma \in \widehat{\mathcal{O}}_{2g}$ (i.e. it is built from closed Reeb orbits in N) and the image of u is contained in W_+ .*

Proof. Since $\mathcal{F}(u) = 0$, the image of u is contained in $X_+ \setminus S_z$, where Ω_{X_+} is exact. Thus an energy estimate shows that γ is built from closed Reeb orbits in N plus e' and h' because orbits in $\text{int}(V)$ and in the no man's land are long. Then, using positivity of intersection with the J^+ -holomorphic surfaces $C_\theta = B_+ \times \{\theta\} \subset W_+$, where $\theta \in \partial S$, we obtain that γ is built from closed orbits in N and the image of u is contained in W_+ . \square

If $\Omega_{X_+}|_{W_+}$ is sufficiently close to Ω_+ , not only we can identify $ECC_{2g}(N, \alpha)$ and $PFC_{2g}(N, \alpha_0, \omega)$, but we can also choose J^+ on X_+ and J_+ on W_+ so that there is a bijection between J^+ -holomorphic curves contained in W_+ and J_+ -holomorphic curves. Then Lemma 4.5.5 implies that there is a commutative diagram

$$\begin{array}{ccc} \overline{CF}(S, \mathbf{a}, \hbar(\mathbf{a})) & \longrightarrow & CF^+(\Sigma, \alpha, \beta, z) \\ \downarrow \overline{\Phi} & & \downarrow \Phi^+ \\ ECC_{2g}(N) & \longrightarrow & ECC(M) \end{array}$$

where the top arrow is the inclusion $\mathbf{y} \mapsto [\mathbf{y}, 0]$. In homology, both this map and $\overline{\Phi}$ factor through $\widehat{HF}(S, \mathbf{a}, \hbar(\mathbf{a}))$, and this proves the commutativity of the left-hand square.

The next theorem is proved by an algebraic trick which generalises Ozsváth and Szabó's observation that $\widehat{HF}(M)$ is trivial if and only if $HF^+(M)$ is trivial³² in [92, Proposition 2.1].

Proposition 4.5.6 (See [13, Theorem 6.1.5]). *Φ_*^+ is an isomorphism if and only if $\widehat{\Phi}_*$ is an isomorphism.*

4.6 The closed-open map Ψ

In this section we will define a closed-open map

$$\Psi: PFC_{2g}(N, \omega, \alpha_0) \rightarrow \widehat{CF}(S, \mathbf{a}, \hbar(\mathbf{a})).$$

³² $\widehat{HF}(M)$ and $HF^+(M)$ are never trivial, but subgroups associated to some Spin^c structures can be trivial.

First, we observe that the naive map that we would obtain by turning the cobordism W_+ “upside-down” does not work: if we stack W_+ on top of the upside-down cobordism, which we will call W_- , the map we obtain is not homotopic to the identity because holomorphic curves from an Heegaard Floer generator to itself have negative index. A similar phenomenon happens in [33], where the composition of the open-closed map from Hochschild homology to symplectic cohomology with the closed-open map from symplectic cohomology to Hochschild cohomology is a “Poincaré duality” rather than the identity. In our case, to amend the naive map, we cap off the surface S with a disc, but this operation comes with the price of working with holomorphic curves with boundary conditions on a *singular Lagrangian with boundary*, which introduces an incredible amount of complication.

4.6.1 Definition of Ψ

Let D be a disc. On D we consider polar coordinates (ρ, ϕ) with $\rho \in [0, 1]$ and write z_∞ for the origin. Let \bar{S} be the capped-off surface obtained by gluing D to S along their boundary. For every $m \gg 0$ (i.e. large enough that all conditions we impose on it make sense) we define a diffeomorphism $\bar{h}_m : \bar{S} \rightarrow \bar{S}$ such that

$$\bar{h}_m|_S = \mathfrak{h} \quad \text{and} \quad \bar{h}_m|_D(\rho, \phi) = (\rho, \phi + \nu_m(\rho))$$

where $\nu_m(\rho) = \frac{2\pi}{m}$ for $\rho \leq \frac{1}{2}$, $\nu_m(\rho) > 0$ for $\rho \in [0, 1)$ and $\nu_m(1) = 0$. We also assume that \bar{h}_m converges to a diffeomorphism \bar{h}_∞ for $m \rightarrow \infty$. For the complete list of properties of ν_m see [14, Subsection 5.1.2] and for a graphical description of the action of \bar{h}_m on D see Figure 4.6. Most of the time we will write \bar{h} for \bar{h}_m and assume $m \gg 0$. Similarly, every object depending on \bar{h}_m may or may not have an index m depending on the context.

We extend the arcs a_i in S to arcs \bar{a}_i in \bar{S} by straight lines in D , so that they all meet at z_∞ . We assume, among other things, that the angles at z_∞ between two consecutive arcs is an integer multiple of $\frac{2\pi}{m}$ larger than $\frac{4\pi g}{m}$ and that, as $m \rightarrow \infty$, the portions of the arcs in $D_{1/2} = \{\rho \leq 1/2\}$ converge to the segment $\{\phi = 0\}$. This last property will be used in the proof of Theorem 4.6.4. See [14, subsection 5.2.2] for the complete description of the arcs \bar{a}_i .

Let B_- be the unit disc with one puncture in the interior and one puncture on the boundary, which we identify biholomorphically with the subset of the cylinder $\mathbb{R} \times \mathbb{R}/2\mathbb{Z}$ obtained by rounding the corners of $\mathbb{R} \times \mathbb{R}/2\mathbb{Z} \setminus (-\infty, -2) \times (1, 2)$. We define a fibration

$$\pi_{\bar{W}_-} : \bar{W}_- \rightarrow B_-$$

with fibre \bar{S} and monodromy \bar{h} , and equip the total space with the symplectic form $\bar{\Omega}_- = ds \wedge dt + \bar{\omega}$, where (s, t) are coordinates on $B_- \subset \mathbb{R} \times \mathbb{R}/2\mathbb{Z}$ and $\bar{\omega}$ is an area form on \bar{S} which is preserved by \bar{h} and extends ω . We can view $(\bar{W}_-, \bar{\Omega}_-)$

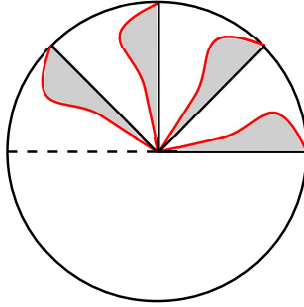

Figure 4.6: The extended arcs and the action of \bar{h}_m on D . The black arcs are portions of the \bar{a}_i and the red ones are portions of the $\bar{h}(\bar{a}_i)$.

as a symplectic cobordism (with boundary) from \bar{N} to $[0, 1] \times \bar{S}$, where \bar{N} is the mapping torus of (\bar{S}, \bar{h}) . We refer to [14, Section 5] for more details about this construction. Note that \bar{N} carries a stable Hamiltonian structure $(\bar{\alpha}_0, \bar{\omega})$ which is induced by the fibration $\bar{\pi}: \bar{N} \rightarrow S^1$. Its only closed Reeb orbit contained in $\bar{N} \setminus N$ and intersecting a fibre at most $2g$ times is the orbit δ_0 corresponding to z_∞ .

In \bar{W}_- there is the subset W_- which is the total space of the fibration over B_- with fibre S and monodromy \bar{h} . Since $\bar{h}|_D$ is isotopic to the identity, there is an identification $\bar{W}_- \setminus \text{int}(W_-) \cong B_- \times D$ which induces a map³³

$$\pi_D: \bar{W}_- \setminus \text{int}(W_-) \rightarrow D.$$

We will denote similar maps for $\mathbb{R} \times [0, 1] \times \bar{S}$ and $\mathbb{R} \times \bar{N}$ by the same symbol.

We define an immersed Lagrangian submanifold with boundary $L_{\bar{\mathbf{a}}}$ by parallel transport of $\bar{\mathbf{a}} = (\bar{a}_1, \dots, \bar{a}_{2g})$ placed at the fibre over $(-3, 1)$. Then,

$$\begin{aligned} L_{\bar{\mathbf{a}}} \cap (-\infty, -3] \times \{1\} \times \bar{S} &= (-\infty, -3] \times \{1\} \times \bar{\mathbf{a}} \\ L_{\bar{\mathbf{a}}} \cap (-\infty, -3] \times \{0\} \times \bar{S} &= (-\infty, -3] \times \{0\} \times \bar{h}(\bar{\mathbf{a}}). \end{aligned}$$

The manifold $L_{\bar{\mathbf{a}}}$ is embedded in the interior and has a clean self-intersection at the boundary.

We fix an almost complex structure J_- on \bar{W}_- which is generic among those whose restriction to $\bar{W}_- \setminus \text{int}(W_-)$ is the pull back of a split almost complex structure on $B_- \times D$ so that, in particular, the map π_D is holomorphic.

We call $\sigma_\infty^- = B_- \times \{z_\infty\} \subset \bar{W}_-$ the *section at infinity*. For our choice of almost complex structure, σ_∞^- is holomorphic, regular (i.e. its linearised Cauchy-Riemann operator is surjective) and $\text{ind}(\sigma_\infty^-) = 0$; see [14, Lemma 5.8.9].

We denote by $\bar{\mathcal{O}}_{2g}$ the set of orbit sets built from closed Reeb orbits in \bar{N} with total intersection number $2g$ with a fibre and by $\mathcal{S}_{\bar{\mathbf{a}}, \bar{h}(\bar{\mathbf{a}})}$ the set of $2g$ -tuples of

³³This map is called $\bar{\pi}_{D^2}$ in [14].

intersection points between $\bar{\mathbf{a}}$ and $\bar{h}(\bar{\mathbf{a}})$. A subtlety in the definition of $\mathcal{S}_{\bar{\mathbf{a}}, \bar{h}(\bar{\mathbf{a}})}$ is that z_∞ can be repeated, unlike all other intersection points, because it can be seen as an intersection point between different pairs of arcs. We denote the moduli space of J_- -holomorphic curves in \bar{W}_- with boundary on $L_{\bar{\mathbf{a}}}$, positively asymptotic to $\gamma \in \bar{\mathcal{O}}_{2g}$ and negatively asymptotic to $\mathbf{y} \in \mathcal{S}_{\bar{\mathbf{a}}, \bar{h}(\bar{\mathbf{a}})}$ by $\mathcal{M}_{\bar{W}_-}(\gamma, \mathbf{y})$. We also fix the base point $\mathbf{m} = \{(0, \frac{3}{2})\} \times \{z_\infty\} \in \bar{W}_-$ and denote the set of J_- -holomorphic curves in $\mathcal{M}_{\bar{W}_-}(\gamma, \mathbf{y})$ which pass through \mathbf{m} by $\mathcal{M}_{\bar{W}_-}(\gamma, \mathbf{y}; \mathbf{m})$.

Let $z_\infty^\dagger \in \bar{S}$ be a point near z_∞ in the complement of the arcs $\bar{\mathbf{a}}$ and $\bar{h}(\bar{\mathbf{a}})$. We denote by $(\sigma_\infty^-)^\dagger$ the J_- -holomorphic multisection which intersects each fibre in the orbit of z_∞^\dagger under the monodromy \bar{h} . We recall that \bar{h} has order $m \gg 0$ near z_∞ and therefore $(\sigma_\infty^-)^\dagger$ intersects each fibre m times. Given a J_- -holomorphic map $u \in \mathcal{M}_{\bar{W}_-}(\gamma, \mathbf{y})$, we define $n_*(u)$ as the algebraic intersection number between $(\sigma_\infty^-)^\dagger$ and the image of u . The orbit of z_∞^\dagger gives rise to holomorphic multisections and to intersection numbers, still denoted by n_* , also in $\mathbb{R} \times \bar{N}$ and $\mathbb{R} \times [0, 1] \times \bar{S}$. Since both $(\sigma_\infty^-)^\dagger$ and u are J_- -holomorphic, $n_*(u) \geq 0$ by positivity of intersection. To u we associate also an ECH-type index $I(u)$; see Definition 5.6.6 and Subsection 5.7.7. If u has no ends at δ_0 or at the chord over z_∞ , then $I(u) \geq 0$ for a generic J_- by the index inequality [14, Theorem 5.6.9]. Moreover, $I(\sigma_\infty^-) = 0$.

We define a map $\bar{\Psi}: ECC_{2g}(N, \alpha_0, \omega) \rightarrow \overline{CF}(S, \mathbf{a}, h(\mathbf{a}))$ by

$$\bar{\Psi}(\gamma) = \sum_{\mathbf{y} \in \mathcal{S}_{\mathbf{a}, h(\mathbf{a})}} \#\mathcal{M}_{\bar{W}_-}^{I=2, n_*=m}(\gamma, \mathbf{y}; \mathbf{m})\mathbf{y}$$

(where $\gamma \in \widehat{\mathcal{O}}_{2g}$) and, finally, the map $\Psi: ECC_{2g}(N, \alpha_0, \omega) \rightarrow \widehat{CF}(S, \mathbf{a}, h(\mathbf{a}))$ by composing $\bar{\Psi}$ with the projection $\overline{CF}(S, \mathbf{a}, h(\mathbf{a})) \rightarrow \widehat{CF}(S, \mathbf{a}, h(\mathbf{a}))$.

By a standard argument involving the index inequality we can prove that the moduli spaces $\mathcal{M}_{\bar{W}_-}^{I=2, n_*=m}(\gamma, \mathbf{y}; \mathbf{m})$ are zero-dimensional manifolds. However, showing that they are compact, and even more showing that Ψ is a chain map, occupy a large portion of [14] because of the unusual structure of the Lagrangian boundary condition $L_{\mathbf{a}}$ and the presence of the extra orbit δ_0 and intersection point z_∞ . In the next subsection we will give an outline of the argument.

4.6.2 Ψ is a chain map

To prove that Ψ is a chain map we analyse the boundary of the compactification of the one-dimensional moduli spaces $\mathcal{M}_{\bar{W}_-}^{I=3, n_*=m}(\gamma, \mathbf{y}; \mathbf{m})$. The first step is to verify that SFT compactness holds.

Theorem 4.6.1 (See [14, Section 7.3]). *Let u_n be a sequence of holomorphic curves in $\mathcal{M}_{\bar{W}_-}^{I=i, n_*=m}(\gamma, \mathbf{y}; \mathbf{m})$. Then, up to taking a subsequence, u_n converges in the SFT sense to a building $u_\infty = (u_\infty^{-h}, \dots, u_\infty^0, \dots, u_\infty^l)$, where u_∞^k is one of the following:*

- a holomorphic curve in \overline{W}_- with boundary on $L_{\overline{\mathbf{a}}}$ and passing through \mathbf{m} for $k = 0$,
- a holomorphic curve in $\mathbb{R} \times \overline{N}$ for $k > 0$, or
- a holomorphic curve in $\mathbb{R} \times [0, 1] \times \overline{S}$ with boundary on $(\mathbb{R} \times \{1\} \times \overline{\mathbf{a}}) \cup \mathbb{R} \times (\{0\} \times \overline{h(\overline{\mathbf{a}})})$ for $k < 0$.

Moreover u_∞^l has positive ends at $\boldsymbol{\gamma}$, u_∞^{-h} has negative ends at \mathbf{y} and the positive ends of u_∞^k match with the negative ends of u_∞^{k+1} for $k = -h, \dots, l-1$. Finally, $I(u_\infty^{-h}) + \dots + I(u_\infty^l) = i$ and $n_*(u_\infty^{-h}) + \dots + n_*(u_\infty^l) = m$.

Despite the unusual situation, the proof of Theorem 4.6.1 follows the proof of the usual SFT compactness theorem in [4] very closely. See [14, Section 7.3] for the details. Even if $\boldsymbol{\gamma} \in \widehat{\mathcal{O}}_{2g}$ and $\mathbf{y} \in \mathcal{S}_{\mathbf{a}, h(\mathbf{a})}$, the holomorphic curves u_∞^k can have one of the following features, which we will call “bad degenerations”:

- (i) ends at δ_0 (for $k \geq 0$) or at the chord over z_∞ (for $k \leq 0$),
- (ii) boundary points at the boundary³⁴ of $L_{\overline{\mathbf{a}}}$, or
- (iii) closed irreducible components.

Any bad degeneration appearing in the compactification of $\mathcal{M}_{\overline{W}_-}^{I=3, n_*=m}(\boldsymbol{\gamma}, \mathbf{y}; \mathbf{m})$ gives rise to a boundary component which contributes neither to $\partial \circ \overline{\Psi}$ nor $\overline{\Psi} \circ \partial$. In fact, it will turn out that $\overline{\Psi}$ is not a chain map, but we will be able to exclude enough bad degenerations and show that the contribution of the remaining ones is in the kernel of the projection from $\widehat{CF}(S, \mathbf{a}, h(\mathbf{a}))$ to $\widehat{CF}(S, \mathbf{a}, h(\mathbf{a}))$.

In [14, Section 7.5] we use topological tools — the intersection numbers n_* and the ECH-type index — to prove that bad degenerations can follow only a limited number of patterns, which are described in [14, Theorem 7.6.1], and then we exclude all patterns but one by studying, via a rescaling argument inspired by [68], how the sequence u_n approaches the limit. For sake of simplicity, here we will outline a slightly different argument, which has the advantage of highlighting the main ideas while being simpler to describe.

Definition 4.6.2. A *thin strip* is a holomorphic curve u in $\mathbb{R} \times [0, 1] \times D$ such that $\pi_D \circ u$ covers the small bigon in D between an arc in \overline{a}_i and its image under \overline{h} .

A thin strip is positively asymptotic to the chord over z_∞ and negatively asymptotic to a chord over one among the intersection points x_i or x'_i . Moreover, if u is a thin strip, then it is regular and satisfies $I(u) = 1$ and $n_*(u) = 1$. The next proposition summarises some of the results of [14, Section 7.5].

³⁴This type of bad degeneration is called “boundary points at z_∞ ” in [14].

Proposition 4.6.3. *Let u_n be a sequence of J_- -holomorphic curves in $\mathcal{M}_{\overline{W}_-}^{n_* = m}(\gamma, \mathbf{y}; \mathbf{m})$ converging to $u_\infty = (u_\infty^{-h}, \dots, u_\infty^0, \dots, u_\infty^l)$. Then the following hold:*

1. *there is at most one nontrivial negative end (i.e. which does not belong to a trivial cylinder) at a cover of δ_0 in all u_∞^k with $k > 0$;*
2. *if one of the holomorphic curves u_∞^k has a negative end at a cover of δ_0 , then u_∞^0 has an irreducible component which is a cover of the section at infinity σ_∞^- ;*
3. *if some u_∞^k with $k < 0$ has a positive end at the chord over z_∞ , then some u_∞^k with $k > 0$ has a negative end at a cover of δ_0 ;*
4. *any nontrivial irreducible component of u_∞^k (with $k < 0$) with a positive end at the chord over z_∞ is a thin strip;*
5. *no u_∞^k has a boundary point at the boundary of $L_{\overline{\mathbf{a}}}$; and*
6. *no u_∞^k has a closed irreducible component.*

Sketch of proof. The main tool is the analysis of the contributions of ends at covers of δ_0 , ends at the chord over z_∞ and boundary points at the boundary of $L_{\overline{\mathbf{a}}}$ to $n_*(u_\infty)$. By [14, Lemma 7.4.1], a nontrivial positive end at a p -fold cover of δ_0 contributes at least p to $n_*(u_\infty)$, while a nontrivial negative end contributes at least $m - p$. By [14, Lemma 7.4.2] a nontrivial positive end at the chord over z_∞ contributes 1 to $n_*(u_\infty)$ if it belongs to a thin strip, and at least $2g$ otherwise, while a nontrivial negative end contributes at least $2g$. Finally, by [14, Lemma 7.4.4] a boundary point at the boundary of $L_{\overline{\mathbf{a}}}$ contributes at least $2g$. All these claims are easy consequences of positivity of intersection between holomorphic curves. As an example, we will compute the contribution of a boundary point at the boundary of $L_{\overline{\mathbf{a}}}$ in u_∞^0 . The composition $\pi_D \circ u_\infty^0$ is defined and holomorphic in a neighbourhood of such a point. Since holomorphic functions are open, its image covers a region between two arcs in $\overline{\mathbf{a}}$ in a neighbourhood of z_∞ . Thus, if we take z_∞^\dagger close enough to z_∞ , the section $(\sigma_\infty^-)^\dagger$ will intersect the image of u_∞^0 at least $2g$ times near the boundary point at the boundary of $L_{\overline{\mathbf{a}}}$.

Suppose that there are two nontrivial negative ends at δ_0 with multiplicity p' and p'' respectively. Then they contribute $2m - p' - p''$ to $n_*(u_\infty)$. Since $p' + p'' \leq 2g \ll m$ and $n_*(u_\infty) = m$, we have a contradiction. This proves (1).

The map $\pi_D \circ u_\infty^0$ is holomorphic, and therefore open, in a neighbourhood of the point mapped to \mathbf{m} . Thus, by unique continuation of holomorphic curves, a neighbourhood of that point contributes m to $n_*(u_\infty)$, unless the irreducible component of u_∞^0 passing through \mathbf{m} is a cover of the section at infinity σ_∞^- . This proves (2).

A nontrivial negative end at a chord over z_∞ contributes at least $2g$ to $n_*(u_\infty)$. Thus, by the argument above, if there is a positive end at a chord over z_∞ ,

an irreducible component of u_∞^0 is a cover of σ_∞^- , and thus, for some $k > 0$, the holomorphic curve u_∞^k has a nontrivial negative end at a cover of δ_0 . This proves (3).

A nontrivial positive end at a chord over z_∞ contributes at least $2g$ to $n_*(u_\infty)$ unless it belongs to a thin strip. By (3), there is a nontrivial negative end at a cover of δ_0 which contributes $m - p$ with $p < 2g$. This is a contradiction, and thus (4) is proved.

Either there is a nontrivial negative end at a cover of δ_0 , which contributes $m - p$ to $n_*(u_\infty)$, or the irreducible component of u_∞^0 passing through \mathbf{m} is not a cover of σ_∞^- and therefore contributes m to $n_*(u_\infty)$. A boundary point at the boundary of $L_{\bar{\mathbf{a}}}$ contributes at least $2g$, which is a contradiction in both cases because $p < 2g$. This proves (5).

A closed irreducible component of u_∞ is homologous to a branched cover of a fibre \bar{S} . Its Fredholm index, computed by the Riemann-Roch formula, is negative, and therefore such a component cannot exist for a generic almost complex structure J_- .³⁵ This proves (6). \square

Now suppose $\sum_{k=-h}^l I(u_\infty^k) = 3$. By [14, Lemma 7.5.5] $I(u_\infty^0) \geq 0$ and $I(u_\infty^k) \geq 1$ for $k \neq 0$, which implies that we can have buildings with at most four levels in the boundary of the compactification of $\mathcal{M}_{\bar{W}_-}^{I=3, n_*=m}(\gamma, \mathbf{y}; \mathbf{m})$. Moreover $I(u_\infty^0) = 2$ if no irreducible component of u_∞^0 is a cover of σ_∞^- because passing through \mathbf{m} is a codimension-two constraint. Therefore two-level buildings have $I(u_\infty^0) = 2$ and correspond to either $\bar{\Psi} \circ \partial$ or $\partial \circ \bar{\Psi}$. On the other hand, bad degenerations necessarily appear in buildings with three or four levels and have an irreducible component which is a cover of the section at infinity σ_∞^- .

A holomorphic building u_∞ in the compactification of $\mathcal{M}_{\bar{W}_-}^{I=3, n_*=m}(\gamma, \mathbf{y}; \mathbf{m})$ with a bad degeneration is called of type (A) if $I(u_\infty^1) = 2$ and of type (B)³⁶ if $I(u_\infty^1) = 1$. If u_∞ is of type (A), then $u_\infty = (u_\infty^{-1}, u_\infty^0, u_\infty^1)$, where u_∞^0 contains σ_∞^- as an irreducible component and u_∞^{-1} is a thin strip. Buildings of type (B) can be ignored as a consequence of the next theorem. We will use a limiting argument for $m \rightarrow \infty$, and therefore we will have manifolds $\bar{W}_{-,m}$ constructed from \bar{h}_m , almost complex structures $J_{-,m}$ and so on. However, all manifolds $\bar{W}_{-,m}$ are diffeomorphic, so we fix a model \bar{W}_- and regard all $J_{-,m}$ as almost complex structures on it.

Theorem 4.6.4 ([14, Theorem 7.10.1]). *If m is large enough, buildings of type (B) do not appear in the boundary of the compactification of $\mathcal{M}_{(\bar{W}_-, J_{-,m})}^{I=3, n_*=m}(\gamma, \mathbf{y}; \mathbf{m})$ for any $\gamma \in \widehat{\mathcal{O}}_{2g}$ and $\mathbf{y} \in \mathcal{S}_{\mathbf{a}, \bar{h}(\mathbf{a})}$.*

³⁵In [14] we use an ECH index computation to show that a building u_∞ with a closed component has $I > 3$.

³⁶Buildings of type (A) correspond to buildings of type (1) and buildings of type (B) correspond to buildings of type (2) to (6) in [14, Theorem 7.6.1].

The proof of this theorem occupies the subsections from 7.7 to 7.10 of [14]; here we will sketch only the main ideas. Assume that there is a sequence $m_i \rightarrow +\infty$ for $i \rightarrow +\infty$ such that, for any i , there is a sequence of J_{-,m_i} -holomorphic curves $u_{i,j}$ in $\mathcal{M}_{(\overline{W}_-, J_{-,m_i})}^{l=3, n_*=m_i}(\gamma, \mathbf{y}; \mathbf{m})$ converging, as $j \rightarrow +\infty$, to a building $u_{i,\infty}$ with $I(u_{i,\infty}^1) = 1$. We know from Proposition 4.6.3 that there is only one nontrivial negative end in $u_{i,\infty}$ at a cover of δ_0 for every i and, moreover, it must belong to an irreducible component of index one. For simplicity, we assume that the end is at δ_0 ; the case of a nontrivial cover is slightly more complicated, but does not need any new idea. To simplify the situation further, we assume that every $u_{i,\infty}$ contains a level $u_{i,\infty}^1$ with $I(u_{i,\infty}^1) = 1$ from an orbit set γ_+ to an orbit set $\delta_0\gamma_-$, a level $u_{i,\infty}^0$ which contains σ_∞^- as an irreducible component and has other components contained in W_- , and a level $u_{i,\infty}^{-1}$ which is a thin strip from the chord over z_∞ to a chord over one of the intersection points x_i or x'_i . There may be one more level, but it will not be relevant to our argument.

The end of $u_{i,\infty}^1$ at δ_0 (which, we recall, is parametrised by $(s, t) \in (-\infty, 0] \times \mathbb{R}/2\mathbb{Z}$) satisfies the expansion³⁷

$$\pi_D \circ u_{i,\infty}^1(s, t) = e^{\pi(1-\frac{1}{m})s} f_i(t) + o(e^{\pi(1-\frac{1}{m})s}) \quad (4.19)$$

where $f_i(t) = c_i e^{\pi i t}$, with $c_i \in \mathbb{C}$, is the *asymptotic eigenfunction* of the end. See [14, Lemma 7.7.3]. For a generic choice of almost complex structure, and up to taking a subsequence, the coefficients c_i converge to $c \neq 0$ by Lemma 7.7.6 and Lemma 7.7.9 in [14]. Translations in the variable s multiply c_i by a positive real number, and therefore we can assume that $|c| = 1$. Since the moduli spaces of holomorphic curves in $\mathbb{R} \times \overline{N}$ with $I = 1$ and fixed asymptotic eigenfunction are finite up to translations, the set \mathcal{C} of possible limit values c are finite.

Definition 4.6.5 (See [14, Definition 7.7.10]³⁸). A *bad radial ray* in \mathbb{C} is a half-line $-ic\mathbb{R}_+$ for $c \in \mathcal{C}$.

We observe that $-i = e^{\pi \frac{3}{2} t}$ and, as we will see later, it is no coincidence that the projection of \mathbf{m} to B_- is $(0, \frac{3}{2})$. As explained in [14, Remark 7.7.11] we can assume without loss of generality that $-1\mathbb{R}_+$ is not a bad radial ray.

After extracting a diagonal subsequence $u_{i,j(i)}$, we find sequences $R_i^\pm \rightarrow +\infty$ for $i \rightarrow +\infty$ and holomorphic maps $\tilde{u}_i: B_- \cap [-R_i^-, R_i^+] \times \mathbb{R} \times \mathbb{R}/2\mathbb{Z} \rightarrow \overline{W}_-$ (called *truncations* in [14, Subsection 7.8.1]) which parametrise the portions of $u_{i,j(i)}$ contained in a neighbourhood of the section at infinity σ_∞^- . We define holomorphic functions $\tilde{w}_i = \pi_D \circ \tilde{u}_i$ and, after fixing a compact neighbourhood K of $(0, \frac{3}{2})$ in B_- , we define constants $C_i = \|\tilde{w}_i\|_{L^\infty(K)}$ and holomorphic functions

³⁷We apologise with the reader for using i both as an index and to denote the imaginary unit.

³⁸[14, Definition 7.7.10] differs from the definition we give here in the notation (i and \mathcal{C} have a different meaning there) and for the fact that, in [14], we consider also the case of ends to multiple covers of δ_0 .

$w_i = \frac{\tilde{w}_i}{C_i}$. If the diagonal subsequence and the truncations are chosen carefully (i.e. as in [14, Lemma 7.8.4]), the functions w_i converge to a holomorphic function $w_\infty: B_- \rightarrow \mathbb{C}$ such that:

- w_∞ has a unique and simple zero at $(0, \frac{3}{2})$,
- $w_\infty(\partial B_-) \subset \mathbb{R}_+$,
- $\lim_{s \rightarrow +\infty} \frac{w_\infty(s, t)}{|w_\infty(s, t)|} = ce^{i\pi t}$ for some $c \in \mathbb{C}$, and
- $\lim_{s \rightarrow -\infty} w_\infty(s, t) \in \mathbb{R}_+$.

See [14, Theorem 7.8.15].

The map $(s, t) \mapsto (s, 1 - t)$ defines an anti-holomorphic involution of B_- fixing $(0, \frac{3}{2})$ — remember that $t \in \mathbb{R}/2\mathbb{Z}$. The function

$$f(s, t) = w_\infty(s, t) / \overline{w_\infty(s, 1 - t)}$$

is thus holomorphic, bounded, and has real boundary conditions. Moreover, it satisfies $\lim_{s \rightarrow -\infty} f(s, t) = 1$ and therefore, by standard one-variable complex analysis, $f(s, t) = 1$ for all $(s, t) \in B_-$, so $w_\infty(s, t) = \overline{w_\infty(s, 1 - t)}$. This implies that $w_\infty(s, \frac{3}{2}) \in \mathbb{R}$ for all $s \in [-2, +\infty) = B_- \cap (\mathbb{R} \times \{\frac{3}{2}\})$. Since $(0, \frac{3}{2})$ is the unique zero of w_∞ and $w_\infty(\partial B_+) \subset \mathbb{R}_+$, we have $-ic \in -1\mathbb{R}_+$. This is a contradiction because $-1\mathbb{R}_+$ is not a bad radial ray, and therefore we have shown that, for i sufficiently large, no building of type (B) with a simple end at δ_0 can be in the boundary of the moduli space $\mathcal{M}_{(\overline{W}_-, J_-, m_i)}^{I=3, n_*=m_i}(\gamma, \mathbf{y}; \mathbf{m})$.

If the nontrivial end of each $u_{i, \infty}$ at a cover of δ_0 is not simple, the limit of the sequence of holomorphic functions w_i must be taken in the SFT sense and yields a building $w_\infty = (w_\infty^{-a}, \dots, w_\infty^b)$ of holomorphic functions $w_\infty^k: \tilde{F}_\infty^k \rightarrow \mathbb{C}$ where \tilde{F}_∞^k is a branched cover of $\mathbb{R} \times [0, 1]$ for $k < 0$, of B_- for $k = 0$ and of $\mathbb{R} \times S^1$ for $k > 0$. See [14, Subsection 7.8.7]. Then, we apply the involution argument component by component and obtain a similar contradiction. This ends the proof of Theorem 4.6.4.

From now on we will assume that m is large enough that Theorem 4.6.4 holds. In order to prove that Ψ is a chain map, it remains to prove the following.

Theorem 4.6.6 (Reformulation of [14, Theorem 7.2.2]). *If $\gamma \in \widehat{\mathcal{O}}_{2g}$ is an orbit set and $\mathbf{y}, \mathbf{y}' \in \mathcal{S}_{\mathbf{a}, \mathfrak{h}(\mathbf{a})}$ are $2g$ -tuples of intersection points which differ only by replacing one intersection point x_i with x'_i for some i , the numbers of boundary points corresponding to buildings of type (A) in the compactifications of $\mathcal{M}^{I=3, n_*=m}(\gamma, \mathbf{y}; \mathbf{m})$ and $\mathcal{M}^{I=3, n_*=m}(\gamma, \mathbf{y}'; \mathbf{m})$ are equal.*

For the rest of the section we will identify the quotient of a moduli space by the \mathbb{R} action with a slice for that action (i.e the moduli spaces $\widetilde{\mathcal{M}}$ with a slice \mathcal{M} in the corresponding moduli spaces \mathcal{M}).

Let $\mathbf{y}_\infty \in \mathcal{S}_{\bar{\mathbf{a}}, \bar{h}(\bar{\mathbf{a}})}$ be the $2g$ -tuple of intersection points obtained by replacing x_i or x'_i in \mathbf{y} or \mathbf{y}' with z_∞ . We fix $\gamma' \in \widehat{\mathcal{O}}_{2g-1}$ and, for $r \gg 0$, define

$$\mathfrak{P} = [r, +\infty)^2 \times \widetilde{\mathcal{M}}_{\mathbb{R} \times [0,1] \times \overline{S}}^{I=1, n_*=1}(\mathbf{y}_\infty, \mathbf{y}) \times \mathcal{M}_{\overline{W}_-}^{I=0, n_*=0}(\delta_0 \gamma', \mathbf{y}_\infty) \times \widetilde{\mathcal{M}}_{\mathbb{R} \times \overline{N}}^{I=2, n_*=m-1}(\gamma, \delta_0 \gamma').$$

Gluing gives us an embedding³⁹

$$G: \mathfrak{P} \rightarrow \mathcal{M}_{\overline{W}_-}^{I=3, n_*=m}(\gamma, \mathbf{y}).$$

To prove Theorem 4.6.6 we need to understand when the image of G belongs to $\mathcal{M}_{\overline{W}_-}^{I=3, n_*=m}(\gamma, \mathbf{y}; \mathbf{m})$ and show that, essentially, it will only depend on how holomorphic curves in $\widetilde{\mathcal{M}}_{\mathbb{R} \times \overline{N}}^{I=2, n_*=m-1}(\gamma, \delta_0 \gamma')$ approach δ_0 .

To a sequence $(T_{-,n}, T_{+,n}, u^{-1}, u^0, u^1) \in \mathfrak{P}$ with $T_{\pm, n} \rightarrow +\infty$ we associate a holomorphic function $w: B_- \rightarrow \mathbb{C}$ by the truncate-and-rescale technique used in the proof of Theorem 4.6.4 applied to the sequence $G(T_{-,n}, T_{+,n}, u^{-1}, u^0, u^1)$. We can see this function as a sort of normal vector to (u^{-1}, u^0, u^1) in the compactification of the moduli space $\mathcal{M}_{\overline{W}_-}^{I=3, n_*=m}(\gamma, \mathbf{y})$ along which the sequence $G(T_{-,n}, T_{+,n}, u^{-1}, u^0, u^1)$ approaches (u^{-1}, u^0, u^1) .

The function w satisfies the following properties:

- $w(s, t) \in \mathbb{R}^+ \cdot e^{i\eta(t)}$ for all $(s, t) \in \partial B_-$, where $\eta: [0, 1] \rightarrow \mathbb{R}$ is a decreasing function (depending only on $L_{\bar{\mathbf{a}}}$) such that $\eta(0) = \frac{\pi}{m}$ and $\eta(1) = 0$;
- $\lim_{s \rightarrow -\infty} |w(s, t) - c_1 e^{-\frac{\pi}{m}(s+it-i)}| < \infty$ for some $c_1 \in \mathbb{R}^+$; and
- $\lim_{s \rightarrow +\infty} |w(s, t) - c_2 e^{\pi(s+it)}| < \infty$ for some $c_2 \in \mathbb{C}^\times$.

Functions of this sort form a non-empty open cone \mathcal{N} inside a three-dimensional real vector space, are determined by the constants c_1 and c_2 and have a unique zero. See [14, Subsection 7.12.1] for the proof of all these properties (and more). Moreover, the zero of a holomorphic function w associated to a sequence $(T_{-,n}, T_{+,n}, u^{-1}, u^0, u^1)$ is the limit of the projections to B_- of the intersection points between the image of $G(T_{-,n}, T_{+,n}, u^{-1}, u^0, u^1)$ and the section at infinity σ_∞^- .

The careful reader has surely observed that the truncate-and-rescale technique in the proof of Theorem 4.6.4 produced functions which were bounded for $s \rightarrow -\infty$,

³⁹Strictly speaking, we should allow the glued curve to have boundary on the Lagrangian submanifolds associated to the extension of the arcs \bar{a}_i to the other side of z_∞ ; these are the *extended moduli spaces* of [14, Definition 5.7.24]. However, [14, Claim 7.12.12] shows that this is a technical complication which can be ignored at a first reading.

while here they have a pole of order $\frac{\pi}{m}$. The reason is that there we took a limit for $m \rightarrow +\infty$ which made the pole disappear; on the other hand, here we work with a large, but fixed value of m .

We fix $r_0 > r$ and denote $\partial\mathfrak{P}_{(r_0)} = \{T_+ = r_0\} \subset \mathfrak{P}$. If r_0 is generic and sufficiently large, then $G(\partial\mathfrak{P}_{(r_0)})$ intersects transversely every branch of the moduli spaces $\mathcal{M}_{\overline{W}_-}^{I=3, n_*=m}(\gamma, \mathbf{y}; \mathbf{m})$ converging to a building (u^{-1}, u^0, u^+) with $u^{-1} \in \widetilde{\mathcal{M}}_{\mathbb{R} \times [0,1] \times \overline{S}}^{I=1, n_*=1}(\mathbf{y}_\infty, \mathbf{y})$, $u^0 \in \mathcal{M}_{\overline{W}_-}^{I=0, n_*=0}(\delta_0 \gamma', \mathbf{y}_\infty)$ and $u^+ \in \widetilde{\mathcal{M}}_{\mathbb{R} \times \overline{N}}^{I=2, n_*=m-1}(\gamma, \delta_0 \gamma')$.

We define $\Upsilon': \partial\mathfrak{P}_{(r_0)} \rightarrow B_-$ such that $\Upsilon'(T_-, r_0, u^{-1}, u^0, u^+)$ is the projection to B_- of the intersection point between the image of $G(T_-, r_0, u^{-1}, u^0, u^+)$ and σ_∞^- . We define a second map $\Upsilon'': \partial\mathfrak{P}_{(r_0)} \rightarrow B_-$ such that $\Upsilon''(T_-, r_0, u^{-1}, u^0, u^+)$ is the (unique) zero of a holomorphic function w whose constants c_1 and c_2 are determined by the asymptotic eigenfunctions of $u^{\pm 1}$. Both functions are proper, and therefore their degrees are well defined.

For r_0 large enough, the holomorphic curves in $G(\partial\mathfrak{P}_{(r_0)})$ which intersect σ_∞^- near \mathbf{m} are close to breaking into the building (u^{-1}, u^0, u^+) by [14, Lemma 7.12.15], so Υ' and Υ'' are C^0 close by the truncate-and-rescale argument defining w and therefore they have the same degree. Since $(0, \frac{3}{2})$ is a regular value for Υ' and Υ'' depends only on the asymptotic eigenfunctions of the ends of $u^{\pm 1}$, this implies that the cardinality of the set

$$G(\partial\mathfrak{P}_{(r_0)}) \cap \mathcal{M}_{\overline{W}_-}^{I=3, n_*=m}(\gamma, \mathbf{y}; \mathbf{m})$$

depends only on the asymptotic eigenfunctions of the ends of $u^{\pm 1}$. Now recall that u^{-1} is a thin strip. The asymptotic eigenfunction of its positive end, which can be easily computed explicitly — see [14, Subsection 7.7.1], depends only by the local behavior of the arcs \bar{a}_i and $\bar{h}(\bar{a}_i)$, which is the same for both ends of the arc. Thus the same construction with \mathbf{y}' at the place of \mathbf{y} gives the same result. Thus we have proved the following theorem.

Theorem 4.6.7. *Ψ is a chain map.*

4.7 Homotopies

In this section we prove the following.

Theorem 4.7.1. $\Phi_*: \widehat{HF}(S, \mathbf{a}, \mathfrak{h}(\mathbf{a})) \rightarrow PFH_{2g}(N, \alpha_0, \omega)$ is an isomorphism.

In order to prove Theorem 4.7.1 we define a chain homotopy H between $\Psi \circ \Phi$ and a quasi-isomorphism Θ , and a chain homotopy K between $\Phi \circ \Psi$ and the identity. These chain homotopies are defined by counting isolated holomorphic curves in one-parameter families of cobordisms. The definition of these maps and the proof that they have the required properties occupies the largest part of [15].

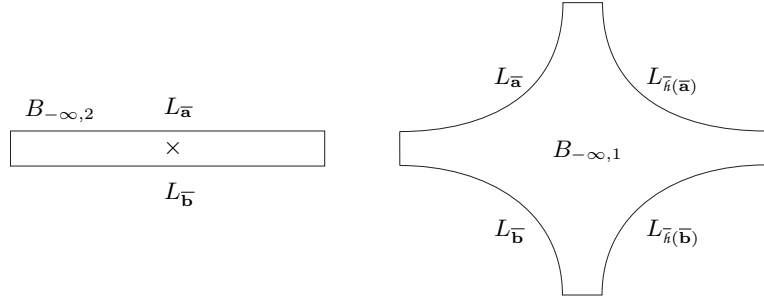

Figure 4.7: The surface $B_{-\infty,2}$ to the left and $B_{-\infty,1}$ to the right. The \times represents the point $\mathfrak{b}_{-\infty}$ and the label on the boundary are the Lagrangian submanifolds.

We define the fibration $\pi_{\overline{W}_+} : \overline{W}_+ \rightarrow B_+$ with fibre \overline{S} and monodromy \overline{h} . In \overline{W}_+ we consider the singular Lagrangian submanifold $L_{\mathbf{a}} \subset \partial\overline{W}_+$ defined as the trace of the parallel transport of a copy of $\overline{\mathbf{a}}$ on $\pi_{\overline{W}_+}^{-1}(3,1)$ along ∂B_+ . Given $\mathbf{y} \in \mathcal{S}_{\mathbf{a},\overline{h}(\mathbf{a})}$ and $\gamma \in \widehat{\mathcal{O}}_{2g}$, we denote by $\mathcal{M}_{\overline{W}_+}(\mathbf{y}, \gamma)$ the moduli space of holomorphic curves in \overline{W}_+ with boundary on $L_{\overline{\mathbf{a}}}$ which are positively asymptotic to $[0,1] \times \mathbf{y}$ and negatively asymptotic to γ . We define the multisection $(\sigma_{\infty}^+)^{\dagger}$ in analogy with $(\sigma_{\infty}^-)^{\dagger}$ in \overline{W}_- and denote the induced intersection number by n_* . If we choose the almost complex structure on \overline{W}_+ so that $(\sigma_{\infty}^+)^{\dagger}$ is holomorphic, by [14, Lemma 5.4.9] we have

$$\mathcal{M}_{\overline{W}_+}^{n_*=0}(\mathbf{y}, \gamma) = \mathcal{M}_{W_+}(\mathbf{y}, \gamma). \quad (4.20)$$

4.7.1 Homotopy for $\Psi \circ \Phi$

For $\tau \in \mathbb{R}$ we define B_{τ} as a smoothing of

$$\mathbb{R} \times \mathbb{R}/2\mathbb{Z} \setminus ((e^{\tau}, +\infty) \times (1,2) \cup (-\infty, -e^{\tau}) \times (1,2)),$$

which can also be seen, up to a biholomorphism, as an annulus with two punctures on the boundary. We choose a smooth family of points⁴⁰

$$\mathfrak{b}_{\tau} \in (-e^{\tau}, e^{\tau}) \times \left\{ \frac{3}{2} \right\} \subset B_{\tau}$$

such that $(B_{\tau}, \mathfrak{b}_{\tau})$ converges, as $\tau \rightarrow \pm\infty$, to $(B_{\pm\infty}, \mathfrak{b}_{\pm\infty})$ where:

- $B_{+\infty} = B_+ \sqcup B_-$ (with B_+ on top of B_-) and $\mathfrak{b}_{+\infty} = (0, \frac{3}{2}) \in B_-$, and

⁴⁰These points are denoted by $\overline{\mathfrak{m}}^b(\tau)$ in [15].

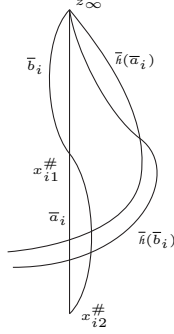

Figure 4.8: The arcs \bar{a}_i , \bar{b}_i , $\bar{h}(\bar{a}_i)$, and $\bar{h}(\bar{b}_i)$ near z_∞ .

- $B_{-\infty} = B_{-\infty,1} \sqcup B_{-\infty,2}$ where $B_{-\infty,1}$ is obtained from $\{-2 \leq s \leq 2\} \cup \{0 \leq t \leq 1\} \subset \mathbb{R}^2$ by smoothing the corners (and therefore is biholomorphic to $D^2 \setminus \{\pm 1, \pm i\}$), $B_{-\infty,2} = [-2, 2] \times \mathbb{R}$ and $\mathfrak{b}_{-\infty} = (0, 0) \in [-2, 2] \times \mathbb{R}$. See Figure 4.7.

Every B_τ admits an anti-holomorphic involution which contains \mathfrak{b}_τ in its fixed point set. This property is used in a symmetry argument similar to that of Subsection 4.6.2.

For each $\tau \in \mathbb{R}$, we define a fibration

$$\pi_{\overline{W}_\tau} : \overline{W}_\tau \rightarrow B_\tau$$

with fibre \overline{S} and monodromy \bar{h} (depending on an integer $m \gg 0$ which will be suppressed from the notation; the reader should keep in mind that all statements hold for m large enough). For $\tau = \pm\infty$ the fibrations extends to fibrations over the limit surfaces. The total space \overline{W}_τ (for $\tau \in \mathbb{R} \cup \{\pm\infty\}$) admits a symplectic form $\Omega_{\overline{W}_\tau}$ such that all fibres are symplectic.

Let $\overline{\mathfrak{b}} = (\bar{b}_1, \dots, \bar{b}_{2g})$ be small Hamiltonian perturbations of $\overline{\mathfrak{a}}$ (depending on m) such that

- $\bar{a}_i \cap \bar{b}_i = \{z_\infty, x_{i,1}^\#, x_{i,2}^\#, x_{i,3}^\#\}$, where $x_{i,2}^\# \in \text{int}(S)$ and $x_{i,1}^\#, x_{i,3}^\# \in \overline{S} \setminus S$,
- \bar{b}_i , near z_∞ , is obtained from \bar{a}_i by a small clockwise rotation, and
- \bar{b}_i approaches \bar{a}_i sufficiently fast as $m \rightarrow \infty$.

See Figure 4.8. We denote $\partial_+ B_\tau = \partial B_\tau \cap ([0, +\infty) \times \mathbb{R}/2\mathbb{Z})$ and $\partial_- B_\tau = \partial B_\tau \cap ((-\infty, 0] \times \mathbb{R}/2\mathbb{Z})$. On $\partial_+ B_\tau$ we consider the singular Lagrangian submanifold

$L_{\bar{\mathbf{a}}}$ obtained by parallel transporting $\bar{\mathbf{a}}$ and on $\partial_- B_\tau$ we consider the singular Lagrangian submanifold $L_{\bar{\mathbf{b}}}$ obtained by parallel transporting $\bar{\mathbf{b}}$, so that

$$\begin{aligned} L_{\bar{\mathbf{a}}} \cap [2e^\tau, +\infty) \times \{1\} \times \bar{S} &= [2e^\tau, +\infty) \times \{1\} \times \bar{\mathbf{a}}, \\ L_{\bar{\mathbf{a}}} \cap [2e^\tau, +\infty) \times \{0\} \times \bar{S} &= [2e^\tau, +\infty) \times \{0\} \times \bar{h}(\bar{\mathbf{a}}), \\ L_{\bar{\mathbf{b}}} \cap (-\infty, -2e^\tau] \times \{1\} \times \bar{S} &= (-\infty, -2e^\tau] \times \{1\} \times \bar{\mathbf{b}}, \\ L_{\bar{\mathbf{b}}} \cap (-\infty, -2e^\tau] \times \{0\} \times \bar{S} &= (-\infty, -2e^\tau] \times \{0\} \times \bar{h}(\bar{\mathbf{b}}). \end{aligned}$$

The Lagrangian submanifolds $L_{\bar{\mathbf{a}}}$ and $L_{\bar{\mathbf{b}}}$ induce Lagrangian submanifolds in $\partial\bar{W}_{\pm\infty}$ in an obvious way. See Figure 4.7 for the Lagrangian submanifolds in $\partial\bar{W}_{-\infty}$.

Let $W_\tau \subset \bar{W}_\tau$ be the total space of a fibration with fibre S and monodromy h . We choose a generic family of almost complex structures J_τ on \bar{W}_τ which restrict to the pull-back of a split almost complex structure on $\bar{W}_\tau \setminus W_\tau \cong B_\tau \times D$. We also fix a family of marked points $\mathbf{m}_\tau = (\mathbf{b}_\tau, z_\infty) \in \bar{W}_\tau$.

Given $\mathbf{y}_+ \in \mathcal{S}_{\mathbf{a}, h(\mathbf{a})}$ and $\mathbf{y}_- \in \mathcal{S}_{\mathbf{b}, h(\mathbf{b})}$, we denote the moduli space of pairs (τ, u) , where $\tau \in \mathbb{R}$ and u is a J_τ -holomorphic curve in \bar{W}_τ with boundary on $L_{\bar{\mathbf{a}}} \cup L_{\bar{\mathbf{b}}}$, positively asymptotic to $[0, 1] \times \mathbf{y}_+$, negatively asymptotic to $[0, 1] \times \mathbf{y}_-$ and passing through \mathbf{m}_τ by $\mathcal{M}_{\bar{W}_\tau}(\mathbf{y}_+, \mathbf{y}_-; \mathbf{m}_*)$. To any u in this moduli space we associate the ECH-type index $I(u)$ satisfying the index inequality — see [15, Subsection 3.2.6] — and the intersection number $n_*(u)$, which is the algebraic intersection between u and the J_τ -holomorphic multisection $(\sigma_\infty^\tau)^\dagger$ defined by a point $z_\infty^\dagger \in \bar{S}$ close to z_∞ and not on the arcs $\bar{\mathbf{a}}$ and $\bar{\mathbf{b}}$; see [15, Notation 3.2.9].

Definition 4.7.2. We define⁴¹ the map $\bar{H}: \overline{CF}(S, \mathbf{a}, h(\mathbf{a})) \rightarrow \overline{CF}(S, \mathbf{b}, h(\mathbf{b}))$ by

$$\bar{H}(\mathbf{y}_+) = \sum_{\mathbf{y}_- \in \mathcal{S}_{\mathbf{b}, h(\mathbf{b})}} \# \mathcal{M}_{\bar{W}_*}^{I=1, n_*=m}(\mathbf{y}_+, \mathbf{y}_-; \mathbf{m}_*) \mathbf{y}_-. \quad (4.21)$$

Let \mathcal{S}^\sharp be the set of unordered $2g$ -tuple of intersection points $x_{1, j(1)}^\sharp, \dots, x_{2g, j(2g)}^\sharp$ between $\bar{\mathbf{a}}$ and $\bar{\mathbf{b}}$. In particular no intersection point is equal to z_∞ . Given $\mathbf{y}_+ \in \mathcal{S}_{\mathbf{a}, h(\mathbf{a})}$, $\mathbf{y}_- \in \mathcal{S}_{\mathbf{b}, h(\mathbf{b})}$ and $\mathbf{x}_\pm \in \mathcal{S}^\sharp$, we will denote the moduli spaces of holomorphic curves in $\bar{W}_{-\infty, 1}$ with boundary conditions $L_{\bar{\mathbf{a}}} \cup L_{\bar{\mathbf{b}}} \cup L_{\bar{h}(\bar{\mathbf{b}})} \cup L_{\bar{h}(\bar{\mathbf{a}})}$ and asymptotic to chords over \mathbf{y}_+ , \mathbf{x}_+ , \mathbf{y}_- and $\bar{h}(\mathbf{x}_-)$ at the four ends of $\bar{W}_{-\infty, 1}$ (in counterclockwise order starting from the top) by $\mathcal{M}_{\bar{W}_{-\infty, 1}}(\mathbf{y}_+, \mathbf{x}_+, \mathbf{y}_-, \bar{h}(\mathbf{x}_-))$. Similarly, we denote the moduli space of holomorphic curves in $\bar{W}_{-\infty, 2}$ with boundary conditions $L_{\bar{\mathbf{a}}} \cup L_{\bar{\mathbf{b}}}$ which are asymptotic to chords over \mathbf{x}_\pm^\sharp for $t \rightarrow \pm\infty$ and pass through $\mathbf{m}_{-\infty} = (0, 0)$ by $\mathcal{M}_{\bar{W}_{-\infty, 2}}(\mathbf{x}_+^\sharp, \mathbf{x}_-^\sharp; \mathbf{m}_{-\infty})$. In the following definition we abbreviate $\mathcal{M}_1(\mathbf{y}_+, \mathbf{x}_+^\sharp, \mathbf{y}_-, \bar{h}(\mathbf{x}_-^\sharp)) = \mathcal{M}_{\bar{W}_{-\infty, 1}}^{I=0, n_*=0}(\mathbf{y}_+, \mathbf{x}_+^\sharp, \mathbf{y}_-, \bar{h}(\mathbf{x}_-^\sharp))$ and $\mathcal{M}_2(\mathbf{x}_+^\sharp, \mathbf{x}_-^\sharp) = \mathcal{M}_{\bar{W}_{-\infty, 2}}^{I=2, n_*=m}(\mathbf{x}_+^\sharp, \mathbf{x}_-^\sharp; \mathbf{m}_{-\infty})$.

⁴¹For sake of exposition, we define here a simplified homotopy map.

Definition 4.7.3. We define the map $\bar{\Theta}: \overline{CF}(S, \mathbf{a}, \mathfrak{h}(\mathbf{a})) \rightarrow \overline{CF}(S, \mathbf{b}, \mathfrak{h}(\mathbf{b}))$ as

$$\bar{\Theta}(\mathbf{y}_+) = \sum_{\mathbf{y}_- \in \mathcal{S}_{\mathbf{b}, \mathfrak{h}(\mathbf{b})}} \sum_{\mathbf{x}_{\pm}^{\sharp} \in \mathcal{S}^{\sharp}} \# \left(\mathcal{M}_1(\mathbf{y}_+, \mathbf{x}_+^{\sharp}, \mathbf{y}_-, \bar{\mathfrak{h}}(\mathbf{x}_-^{\sharp})) \times \mathcal{M}_2(\mathbf{x}_+^{\sharp}, \mathbf{x}_-^{\sharp}) \right) \mathbf{y}_-. \quad (4.22)$$

Theorem 4.7.4. The maps \bar{H} and $\bar{\Theta}$ satisfy the relation

$$\bar{\partial} \circ \bar{H} + \bar{H} \circ \bar{\partial} = \bar{\Psi} \circ \bar{\Phi} + \bar{\Theta} + \bar{V} \quad (4.23)$$

for a map \bar{V} whose image is generated by elements of the form $\{x_i\} \cup \mathbf{y}' + \{x'_i\} \cup \mathbf{y}'$ where x_i and x'_i here denote the intersection points of b_i and $\mathfrak{h}(b_i)$ on ∂S and \mathbf{y}' is a $(2g-1)$ -tuple of intersection points between the remaining arcs.

Theorem 4.7.4 is proved by analysing the degenerations of the moduli spaces $\mathcal{M}_{\bar{W}^*}^{I=2, n_*=m}(\mathbf{y}_+, \mathbf{y}_-, \mathbf{m}_*)$. Degenerations which occur at some $\tau \in \mathbb{R}$ contribute to the left hand side, degenerations which occur at $\tau \rightarrow +\infty$ contribute to $\bar{\Psi} \circ \bar{\Phi} + \bar{V}$ and degenerations which occur at $\tau \rightarrow -\infty$ contribute to $\bar{\Theta}$. For $\tau \rightarrow +\infty$, the cobordisms \bar{W}_τ degenerate into the juxtaposition of \bar{W}_+ on top of \bar{W}_- with the base-point $\mathbf{m}_{+\infty} \in \bar{W}_-$. Sequences of holomorphic curves in $\mathcal{M}_{\bar{W}^*}^{I=2, n_*=m}(\mathbf{y}_+, \mathbf{y}_-, \mathbf{m}_*)$ degenerate, for $\tau \rightarrow +\infty$, either to two-level buildings in $\mathcal{M}_{\bar{W}_+}^{I=0, n_*=0}(\mathbf{y}_+, \gamma) \times \mathcal{M}_{\bar{W}_-}^{I=2, n_*=m}(\gamma, \mathbf{y}; \mathbf{m}_{+\infty})$ for some $\gamma \in \widehat{\mathcal{O}}_{2g}$ or to three-level buildings involving a holomorphic curve in \bar{W}_+ with a negative and at δ_0 , the section at infinity σ_∞^- in \bar{W}_- , and a thin strip in $\mathbb{R} \times [0, 1] \times \bar{S}$. The two-level degenerations contribute to $\bar{\Psi} \circ \bar{\Phi}$ by Equation (4.20), while the three-level degenerations contribute to \bar{V} .

The main tools we use in the analysis of bad degenerations are, as for proving that Ψ is a chain map, the intersection numbers n_* , the ECH-type index I and truncate-and-rescale arguments to analyse how a degenerating sequence approaches its limit. However, the cases to treat are many more than in the previous section and their analysis is more difficult.

Theorem 4.7.5. The map $\bar{\Theta}$ induces a quasi-isomorphism

$$\Theta: \widehat{CF}(S, \mathbf{a}, \mathfrak{h}(\mathbf{a})) \rightarrow \widehat{CF}(S, \mathbf{b}, \mathfrak{h}(\mathbf{b})).$$

Before proving Theorem 4.7.5 we explain how, together with Equation (4.23), it proves that $\Psi_* \circ \Phi_*$ is an isomorphism. The missing step is to prove that \bar{H} induces a map $H: \widehat{CF}(S, \mathbf{a}, \mathfrak{h}(\mathbf{a})) \rightarrow \widehat{CF}(S, \mathbf{b}, \mathfrak{h}(\mathbf{b}))$. Unfortunately we were not able to prove directly that $\bar{H}(\{x_i\} \cup \mathbf{y}') = \bar{H}(\{x'_i\} \cup \mathbf{y}')$ if \mathbf{y}' is a $(2g-1)$ -tuple of intersection points between the remaining arcs, and thus we extend all maps in Equation (4.23) to a chain complex generated by $2g$ -tuples of intersection points which can contain z_∞ and whose homology is $\widehat{HF}(S, \mathbf{a}, \mathfrak{h}(\mathbf{a}))$. This, of course, brings in more bad degenerations to control.

Now we sketch the main steps of the proof of Theorem 4.7.5. We consider the two subsets \mathcal{S}_{odd}^\sharp and $\mathcal{S}_{even}^\sharp$ of \mathcal{S}^\sharp : the first consists of $2g$ -tuple $\{x_{1,j(1)}^\sharp, \dots, x_{2g,j(2g)}^\sharp\}$ where $x_{i,j(i)}^\sharp \in \{1, 3\}$, and the second of the unique element $\{x_{1,2}^\sharp, \dots, x_{2g,2}^\sharp\}$. By [15, Lemma 3.2.15], the moduli spaces $\mathcal{M}_{\overline{W}_{-\infty,2}}^{I=2, n_*=m}(\mathbf{x}_+^\sharp, \mathbf{x}_-^\sharp; \mathbf{m}_{-\infty})$ is nonempty only when $\mathbf{x}_-^\sharp \in \mathcal{S}_{odd}^\sharp$ and $\mathbf{x}_+^\sharp \in \mathcal{S}_{even}^\sharp$.

For any $\mathbf{x}_-^\sharp \in \mathcal{S}_{odd}^\sharp$ and $\mathbf{x}_+^\sharp \in \mathcal{S}_{even}^\sharp$, the number of elements in the moduli space $\mathcal{M}_{\overline{W}_{-\infty,2}}^{I=2, n_*=m}(\mathbf{x}_+^\sharp, \mathbf{x}_-^\sharp; \mathbf{m}_{-\infty})$ is equal to the relative Gromov-Taubes invariant G_3 defined as the number of embedded holomorphic curves in $D^2 \times \overline{S}$ with boundary on $\partial D^2 \times \mathbf{a}$, representing the relative homology class $[\overline{S}] + 2g[D^2]$ and passing through $(0, z_\infty), (x_1, 1), \dots, (x_{2g}, 1), (x_{2g+1}, -1), \dots, (x_{4g}, -1)$ with $x_i, x_{i+2g} \in \overline{a}_i$. See [15, Subsection 2.4.1].

By [15, Theorem 2.4.2] $G_3 = 1$; the proof is similar to the computation of the relative Gromov-Taubes invariant in Subsection 4.3.2. Then we can rewrite

$$\overline{\Theta}(\mathbf{y}_+) = \sum_{\mathbf{y}_- \in \mathcal{S}_{\mathbf{b}, \hbar(\mathbf{b})}} \sum_{\mathbf{x}_+^\sharp \in \mathcal{S}_{odd}^\sharp} \sum_{\mathbf{x}_-^\sharp \in \mathcal{S}_{even}^\sharp} \# \mathcal{M}_{\overline{W}_{-\infty,1}}^{I=0, n_*=0}(\mathbf{y}_+, \mathbf{x}_+^\sharp, \mathbf{y}_-, \overline{\hbar}(\mathbf{x}_-^\sharp)) \mathbf{y}_-.$$

This sum now has a fairly standard interpretation in Heegaard Floer theory as composition of two triangle maps which are known to give an isomorphism in homology: see [15, Lemma 3.3.13]. We can also argue as follows: any $2g$ -tuple of intersection points $\mathbf{y}_+ \in \mathcal{S}_{\mathbf{a}, \hbar(\mathbf{a})}$ has a closest $2g$ -tuple of intersection points $\mathbf{y}_- \in \mathcal{S}_{\mathbf{b}, \hbar(\mathbf{b})}$. There is a unique holomorphic curve in $\overline{W}_{-\infty,1}$ of small energy with $I = 0$, $n_* = 0$ and ends at \mathbf{y}_+ , $\mathbf{x}_+^\sharp \in \mathcal{S}_{even}^\sharp$, \mathbf{y}_- and $\mathbf{x}_-^\sharp \in \mathcal{S}_{odd}^\sharp$: it is a union of $2g$ sections whose projection to the fibre covers small fishtail-shaped quadrilateral as those appearing in Figure 4.8.

Remark 4.7.6. It might be surprising, at a first careless look, that those curves have index zero. The reason is that the concave angle gives a holomorphic map from a disc with four punctures on the boundary to \overline{S} covering the quadrilateral for any conformal structure of the puncture disc, which depends on the cross-ratio of the four punctures. However, we are not looking just for maps into \overline{S} but for multisections of $\overline{W}_{-\infty,1} \rightarrow B_{-\infty,1}$, so we also have a holomorphic map from the four punctured disc to $B_{-\infty,1}$. The conformal structure of $B_{-\infty,1}$ is fixed, and that fixes the conformal structure of the four punctured disc.

Thus the “low energy part” of $\overline{\Theta}$ is an isomorphism, and therefore $\overline{\Theta}$ is a quasi-isomorphism by standard homological algebra. If a component of \mathbf{y}_+ is either x_i or x'_i , a direct inspection shows that every element in the moduli space $\mathcal{M}_{\overline{W}_{-\infty,1}}^{I=0, n_*=0}(\mathbf{y}_+, \mathbf{x}_+^\sharp, \mathbf{y}_-, \overline{\hbar}(\mathbf{x}_-^\sharp))$ must have the small energy quadrilateral starting at x_i or x'_i as an irreducible component. This implies that $\overline{\Theta}(\{x_i\} \cup \mathbf{y}') = \overline{\Theta}(\{x'_i\} \cup \mathbf{y}')$ for all \mathbf{y}' , and therefore $\overline{\Theta}$ induces a well defined map $\Theta: \overline{CF}(S, \mathbf{a}, \hbar(\mathbf{a})) \rightarrow \overline{CF}(S, \mathbf{a}, \hbar(\mathbf{a}))$ which is still a quasi-isomorphism.

4.7.2 Homotopy for $\Phi \circ \Psi$

In this section B_τ will denote a family of cylinders with a disc removed which, for $\tau \rightarrow \pm\infty$, converges to $B_{\pm\infty}$ such that:

- $B_{+\infty} = B_- \sqcup B_+$ (with B_- on top of B_+), and
- $B_{-\infty} = B_{-\infty,1} \vee B_{-\infty,2}$ where $B_{-\infty,1} = \mathbb{R} \times \mathbb{R}/2\mathbb{Z}$, $B_{-\infty,2} = D^2$, and the two components are attached by identifying $(0, \frac{3}{2}) \in \mathbb{R} \times \mathbb{R}/2\mathbb{Z}$ with $0 \in D^2$.

In B_τ we choose a marked point \mathfrak{b}_τ (depending smoothly on τ) such that $\lim_{\tau \rightarrow \pm\infty} \mathfrak{b}_\tau = \mathfrak{b}_{\pm\infty}$ where $\mathfrak{b}_{+\infty} = (0, \frac{3}{2}) \in B_-$ and $\mathfrak{b}_{-\infty} = \frac{i}{2} \in D^2$. We will also assume that every B_τ admits an anti-holomorphic involution such that \mathfrak{b}_τ is contained in its fixed point set. This property is used in a symmetry argument similar to that of Subsection 4.6.2.

Definition 4.7.7. We say that the Reeb vector field of N satisfies *Property* $(\dagger\dagger)_i$ if every simple elliptic orbit of degree at most i has first return map which is conjugated to a rotation by a sufficiently small negative angle so that its incoming partition is $\underbrace{(1, \dots, 1)}_{i \text{ times}}$ and its outgoing partition is (i) .

By [14, Section 2.5] it is possible to assume Property $(\dagger\dagger)_i$, for any i , after a C^1 -small modification of the stable Hamiltonian structure supported on arbitrarily small neighbourhoods of the elliptic orbits of degree at most i . Note that we can see Property $(\dagger\dagger)_i$ as a property of the monodromy \mathfrak{h} . In this subsection we will always assume Property $(\dagger\dagger)_{2g}$.

For each $\tau \in \mathbb{R}$, we define a fibration

$$\pi_{\overline{W}_\tau} : \overline{W}_\tau \rightarrow B_\tau$$

with fibre \overline{S} and monodromy \overline{h} (depending on an integer $m \gg 0$ which will be suppressed from the notation). As in the previous subsection, the reader should keep in mind that all statements hold for m large enough. For $\tau = \pm\infty$ these fibrations extend to fibrations over the limit surfaces. The total space \overline{W}_τ (for $\tau \in \mathbb{R} \cup \{\pm\infty\}$) admits a symplectic form $\Omega_{\overline{W}_\tau}$ such that all fibres are symplectic. On $\partial\overline{W}_\tau$, for $\tau \in \mathbb{R} \cup \{\pm\infty\}$, we consider the Lagrangian submanifold $L_{\overline{\mathfrak{a}}}$ defined as the trace of the symplectic parallel transport along ∂B_τ applied to a copy of $\overline{\mathfrak{a}}$ on the fibre over a point of ∂B_τ . We also fixed a family of marked points $\mathfrak{m}_\tau = (\mathfrak{b}_\tau, z_\infty) \in \overline{W}_\tau$.

Let $W_\tau \subset \overline{W}_\tau$ be the total space of the fibration over B_τ with fibre S and monodromy \mathfrak{h} . We choose a generic family of almost complex structures J_τ on \overline{W}_τ among those which restrict to the pull-back of a split almost complex

structure on $\overline{W}_\tau \setminus W_\tau \cong B_\tau \times D$. Since $\overline{W}_{-\infty,1} = \mathbb{R} \times \overline{N}$, we also require that $J_{-\infty,1}$ be compatible with the stable Hamiltonian structure on \overline{N} .

Given orbit sets $\gamma_\pm \in \widehat{\mathcal{O}}_{2g}$, the moduli space of pairs (u, τ) where $\tau \in \mathbb{R}$ and u is a J_τ -holomorphic curve in \overline{W}_τ with boundary on $L_{\overline{\mathbf{a}}}$, positively asymptotic to γ_+ , negatively asymptotic to γ_- and passing through \mathfrak{m}_τ is denoted by $\mathcal{M}_{\overline{W}_*}(\gamma_+, \gamma_-; \mathfrak{m}_*)$. To any u in this moduli space we associate the ECH-type index $I(u)$ satisfying the index inequality — see [15, Subsection 4.2.6] — and the intersection number $n_*(u)$, which is the algebraic intersection between the image of u and the J_τ -holomorphic multisection $(\sigma_\infty^\tau)^\dagger$ defined by a point $z_\infty^\dagger \in \overline{S}$ close to z_∞ and not on the arcs $\overline{\mathbf{a}}$.

Definition 4.7.8. We define the map $K: ECC_{2g}(N, \alpha_0, \omega) \rightarrow ECC_{2g}(N, \alpha_0, \omega)$ by

$$K(\gamma_+) = \sum_{\gamma_- \in \widehat{\mathcal{O}}_{2g}} \# \mathcal{M}_{\overline{W}_*}^{I=1, n_*=m}(\gamma_+, \gamma_-; \mathfrak{m}_*) \gamma_- . \quad (4.24)$$

We say that a holomorphic curve u in $\overline{W}_{-\infty,1}$ passes through $\zeta \in \pi_{\overline{W}_{-\infty,1}}^{-1}(0, \frac{3}{2})$ with multiplicity r if the multiplicity of ζ as intersection point between u and $\pi_{\overline{W}_{-\infty,1}}^{-1}(0, \frac{3}{2})$ is r .⁴² We fix an identification $\pi_{\overline{W}_{-\infty,1}}^{-1}(0, \frac{3}{2}) \cong \overline{S}$. An element $\mathfrak{z} \in Sym^{2g}(\overline{S})$ can be seen as a set of “points with multiplicities” $\mathfrak{z} = \{(\zeta_1, r_1), \dots, (\zeta_l, r_l)\}$ with $\zeta_i \in \overline{S}$, $r_i > 0$ and $r_1 + \dots + r_l = 2g$. Given $\mathfrak{z} \in Sym^{2g}(\overline{S})$, we denote the moduli space of holomorphic curves in $\overline{W}_{-\infty,1} = \mathbb{R} \times \overline{N}$ which are positively asymptotic to γ_+ and negatively asymptotic to γ_- for $\gamma_\pm \in \widehat{\mathcal{O}}_{2g}$ and pass through $\zeta_i \in \pi_{\overline{W}_{-\infty,1}}^{-1}(0, \frac{3}{2})$ with multiplicity r_i by $\mathcal{M}_{\overline{W}_{-\infty,1}}(\gamma_+, \gamma_-; \mathfrak{z})$. Similarly, we denote the moduli space of holomorphic curves in $\overline{W}_{-\infty,2} = D^2 \times \overline{S}$ with boundary on $L_{\overline{\mathbf{a}}} = \partial D^2 \times \overline{\mathbf{a}}$, representing the relative homology class $[\overline{S}] + 2g[D^2]$ and passing through $\mathfrak{m}_\infty = (\frac{i}{2}, z_\infty)$ and $\mathfrak{z} \in Sym^{2g}(\overline{S})$ by $\mathcal{M}_{\overline{W}_{-\infty,2}}(\mathfrak{m}, \mathfrak{z})$.

Definition 4.7.9. We define the map $\Xi: ECC_{2g}(N) \rightarrow ECC_{2g}(N)$ as

$$\Xi(\gamma_+) = \sum_{\gamma_- \in \widehat{\mathcal{O}}_{2g}} \sum_{\mathfrak{z} \in Sym^{2g}(\overline{S})} \# \left(\mathcal{M}_{\overline{W}_{-\infty,1}}^{I=0, n^*=0}(\gamma_+, \gamma_-; \mathfrak{z}) \times \mathcal{M}_{\overline{W}_{-\infty,2}}(\mathfrak{m}, \mathfrak{z}) \right) \gamma_- .$$

The sum is finite because the moduli spaces $\mathcal{M}_{\overline{W}_{-\infty,1}}^{I=0, n^*=0}(\gamma_+, \gamma_-; \mathfrak{z})$ are nonempty only for finitely many $\mathfrak{z} \in Sym^{2g}(\overline{S})$.

The following theorem is proved by analysing the degenerations of the moduli spaces $\mathcal{M}_{\overline{W}_*}^{I=2, n_*=m}(\gamma_+, \gamma_-; \mathfrak{m}_*)$. To control the bad degenerations and show that either they cannot occur or they come in pairs we use a combination of

⁴²To make sense of the multiplicity of the intersection we must assume that $\pi_{\overline{W}_{-\infty,1}}^{-1}(0, \frac{3}{2})$ is holomorphic. In fact, in [14] and [15] we assume that most almost complex structures are compatible with the various fibrations.

intersection theory, index computations, truncate-and-rescale and symmetry arguments like in Subsection 4.6.2.

Theorem 4.7.10. *The maps K and Ξ satisfy the relation*

$$\partial \circ K + K \circ \partial = \Phi \circ \Psi + \Xi. \quad (4.25)$$

Degenerations of $\mathcal{M}_{\overline{W}_*}^{I=2, n_*=m}(\gamma_+, \gamma_-; \mathfrak{m}_*)$ which occur at some $\tau \in \mathbb{R}$ contribute to the left hand side, degenerations which occur at $\tau \rightarrow +\infty$ contribute to $\Phi \circ \Psi$ because $\overline{W}_{+\infty}$ is the juxtaposition of \overline{W}_- on top of \overline{W}_+ and the base point $\mathfrak{m}_{+\infty}$ is in \overline{W}_- , as in the previous subsection, and degenerations which occur at $\tau \rightarrow -\infty$ contribute to Ξ .

Property $(\dagger\dagger)_{2g}$ is used in the proof Theorem 4.7.10 to simplify the gluing of the broken holomorphic curves appearing in the definition of Ξ to holomorphic curves in $\mathcal{M}_{\overline{W}_*}^{I=2, n_*=m}(\gamma, \gamma; \mathfrak{m}_*)$ when there is an elliptic orbit with multiplicity larger than one in γ ; see the proof of [15, Lemma 4.3.4]. We take $\gamma_+ = \gamma_- = \gamma$ because holomorphic curves in $\mathcal{M}_{\overline{W}_{-\infty,1}}^{I=0, n_*=0}(\gamma_+, \gamma_-)$ are necessarily branched covers of trivial cylinders because we have chosen $J_{-\infty, i}$ compatible with the stable Hamiltonian structure.

To exemplify the use of Property $(\dagger\dagger)_{2g}$ suppose for simplicity that we want to glue (v_1, v_2) where $v_1 \in \mathcal{M}_{\overline{W}_{-\infty,1}}^{I=0, n_*=0}(\gamma^{2g}, \gamma^{2g}; \mathfrak{z})$ is a degree $2g$ branched cover of the trivial cylinder over some elliptic orbit γ . Then $\mathfrak{z} = \{(\zeta, 2g)\}$ with $\zeta = \gamma(\frac{3}{2})$. Recall that, in the definition of the moduli spaces for embedded contact homology, branched covers of trivial cylinders with the same degree are identified, but when we glue we must choose a representative. The ends of the curve after gluing must satisfy the incoming and outgoing partitions, which means that we must choose a representative of v_1 satisfying the same conditions. The form of the partitions of γ implies that we can choose v_1 to be a branched cover of γ with a unique branch point at ζ of order $2g - 1$.

To prove that $\Phi_* \circ \Psi_*$ is an isomorphism, it remains to compute Ξ .

Theorem 4.7.11. *Ξ is the identity.*

To prove the theorem, we first compute the number of elements in the moduli spaces $\mathcal{M}_{\overline{W}_{-\infty,2}}(\mathfrak{m}_{-\infty}, \mathfrak{z})$. To do so, we degenerate $B_{-\infty,2} \cong D^2$ into a copy of D^2 attached to a copy of S^2 along a point so that $\mathfrak{m}_{-\infty}$ remains in S^2 . Holomorphic curves in $\mathcal{M}_{\overline{W}_{-\infty,2}}(\mathfrak{m}_{-\infty}, \mathfrak{z})$ degenerate to constant sections of $D^2 \times \overline{S}$ passing through the points in \mathfrak{z} and holomorphic curves in $S^2 \times \overline{S}$ in the homology class $[\overline{S}] + 2g[S^2]$ passing through $\mathfrak{m}_{-\infty}$ and \mathfrak{z} . We denote the moduli space of the latter holomorphic curves by $\mathcal{M}_{S^2 \times \overline{S}}(\mathfrak{m}_{-\infty}, \mathfrak{z})$. Thus $\#\mathcal{M}_{\overline{W}_{-\infty,2}}(\mathfrak{m}_{-\infty}, \mathfrak{z}) = \#\mathcal{M}_{S^2 \times \overline{S}}(\mathfrak{m}_{-\infty}, \mathfrak{z})$. By [15, Theorem 2.3.3] (second Gromov-Witten computation) $\#\mathcal{M}_{S^2 \times \overline{S}}(\mathfrak{m}_{-\infty}, \mathfrak{z}) = 1$ for any $\mathfrak{z} \in \text{Sym}^{2g}(S)$.

The proof is similar to the computation of the relative Gromov-Taubes invariant in Subsection 4.3.2. This computation implies that

$$\Xi(\gamma_+) = \sum_{\gamma_- \in \widehat{\mathcal{O}}_{2g}} \#\mathcal{M}_{\overline{W}_{-\infty,1}}^{I=0, n^*=0}(\gamma_+, \gamma_-)\gamma_-.$$

Since, for a suitable choice of almost complex structure, the moduli space $\mathcal{M}_{\overline{W}_{-\infty,1}}^{I=0, n^*=0}(\gamma_+, \gamma_-)$ consists of trivial cylinders, Ξ is the identity map. This proves Theorem 4.7.11 and therefore concludes the proof of Theorem 4.7.1.

4.8 Stabilisation

In Section 4.7 we proved that $\Phi_*: \widehat{HF}(S, \mathbf{a}, \hbar(\mathbf{a})) \rightarrow PFH_{2g}(N, \alpha_0, \omega)$ is an isomorphism if \hbar satisfies Property $(\dagger\dagger)_{2g}$. In view of Lemma 4.4.24, to prove that $\widehat{\Phi}_*$ is an isomorphism it remains to prove that $PFH_{2g}(N, \alpha_0, \omega)$ is isomorphic to $\overline{PFH}(N, \partial N, \alpha_0, \omega)$; this will be done by a stabilisation argument.

In this section it would be desirable to assume Property $(\dagger\dagger)_i$ for all i , but this is not possible. Nevertheless, in practice, we can pretend it is for the following reason.

Lemma 4.8.1 (See [15, Lemma 5.5.2]). *There is a sequence of stable Hamiltonian structures (α_0^i, ω^i) with Reeb vector field R_i satisfying Property $(\dagger\dagger)_i$ such that*

- R_i and R_{i+1} coincide outside of a small neighbourhood of the orbits of R_i of degree (i.e. intersection with a fibre) $i+1$, and
- the continuation maps

$$\mathfrak{K}_i: PFC_i(N, \alpha_0^i, \omega^i) \rightarrow PFC_i(N, \alpha_0^{i+1}, \omega^{i+1})$$

satisfy $\mathfrak{K}_i(\gamma) = \gamma$ for every generator of $PFC_i(N, \alpha_0^i, \omega^i)$.

This implies that

$$\varinjlim PFC_i(N, \alpha_0^i, \omega^i) = \widehat{PFH}(N, \partial N, \alpha_0^0, \omega^0).$$

Proposition 4.8.2. *If \hbar satisfies Property $(\dagger\dagger)_{2g+2}$, then the map*

$$j: ECC_{2g}(N) \rightarrow ECC_{2g+2}(N), \quad j(\gamma) = e^2\gamma$$

induces an isomorphism in homology.

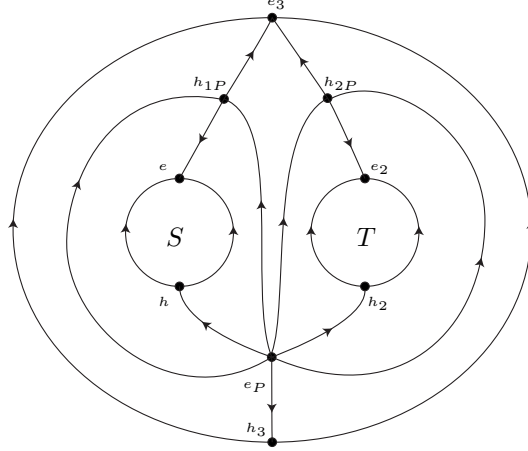

Figure 4.9: The pair of pants P . The negative gradient trajectories of the Morse function f are shown.

We recall that j is a chain map because no holomorphic curve in $\mathbb{R} \times N$ can have a nontrivial positive end at a cover of e .

Let (T, \mathfrak{h}_T) be the open book decomposition of S^3 such that T is a torus with one boundary component and \mathfrak{h}_T is isotopic, relative to the boundary, to the product of right-handed Dehn twists along two curves intersecting exactly at one point. In particular, the binding is the positive trefoil knot. Let N_T be the mapping torus of (T, \mathfrak{h}_T) . We also assume that $\mathfrak{h}_T^* \beta_T - \beta_T$ is exact for some Liouville form β_T on T and that the Reeb vector field of the stable Hamiltonian structure on N_T induced by the fibration is nondegenerate and satisfies Property $(\dagger\dagger)_{2g+2}$ on $\text{int}(N_T)$, while ∂N_T is a negative Morse-Bott torus.

Next, we take a pair of pants P with $\partial P = \partial_1 P \sqcup \partial_2 P \sqcup \partial_3 P$, we fix a symplectic form on P and choose a function $f: P \rightarrow \mathbb{R}$ which is sufficiently close to 1 in the C^∞ topology and such that its negative gradient flow is as shown in Figure 4.9. We denote the time 1 flow of f by \mathfrak{h}_P and the mapping torus of (P, \mathfrak{h}_P) by N_P . Finally, we define $\tilde{S} = P \cup S \cup T$, where $\partial_1 P$ is glued to ∂S and $\partial_2 P$ to ∂T . We define also $\tilde{\mathfrak{h}}: \tilde{S} \rightarrow \tilde{S}$ such that $\tilde{\mathfrak{h}}|_S = \mathfrak{h}$, $\tilde{\mathfrak{h}}|_T = \mathfrak{h}_T$ and $\tilde{\mathfrak{h}}|_P = \mathfrak{h}_P$. Then $(\tilde{S}, \tilde{\mathfrak{h}})$ is an abstract open book decomposition of M with page of genus $2g + 2$ and we denote the mapping torus of $(\tilde{S}, \tilde{\mathfrak{h}})$ by \tilde{N} .

Let $\{a_{2g+1}, a_{2g+2}\}$ be a basis of arcs for T and, for $i = 2g+1$ or $2g+2$, let $\{x_i, x'_i\}$ be the intersection points between a_i and $\mathfrak{h}_T(a_i)$ on ∂T . On \tilde{S} we consider a basis of arcs $\tilde{\mathbf{a}} = (\tilde{a}_1, \dots, \tilde{a}_{2g+2})$ where \tilde{a}_i , for $i = 1, \dots, 2g + 2$, is obtained by extending a_i up to $\partial \tilde{S} = \partial_3 P$. The intersection points between \tilde{a}_i and $\tilde{\mathfrak{h}}(\tilde{a}_i)$ in \tilde{S} will be denoted by \tilde{x}_i and \tilde{x}'_i . Observe that the boundary behavior of the monodromy \mathfrak{h}_P forces one intersection point in $\text{int}(P)$ between \tilde{a}_i and $\tilde{\mathfrak{h}}(\tilde{a}_i)$ for each segment of $\tilde{a}_i \setminus a_i$.

We define the stabilisation map

$$\mathfrak{S}: \widehat{CF}(S, \mathbf{a}, \mathfrak{h}(\mathbf{a})) \rightarrow \widehat{CF}(\widetilde{S}, \widetilde{\mathbf{a}}, \widetilde{\mathfrak{h}}(\widetilde{\mathbf{a}})), \quad \mathfrak{S}(\mathbf{y}) = \mathbf{y} \cup \{\widetilde{x}_{2g+1}, \widetilde{x}_{2g+2}\}.$$

Similarly, we define the stabilisation map

$$\mathfrak{T}: ECC_{2g}(N) \rightarrow ECC_{2g+2}(\widetilde{N}), \quad \mathfrak{T}(\gamma) = e_3^2 \gamma.$$

It is easy to see that \mathfrak{S} and \mathfrak{T} are chain maps.

Lemma 4.8.3. \mathfrak{S} induces an isomorphism in homology.

Proof. One can check that

$$\widehat{HF}(\widetilde{S}, \widetilde{\mathbf{a}}, \widetilde{\mathfrak{h}}(\widetilde{\mathbf{a}})) \cong \widehat{HF}(S, \mathbf{a}, \mathfrak{h}(\mathbf{a})) \otimes \widehat{HF}(T, \mathbf{a}_T, \mathfrak{h}_T(\mathbf{a}_T))$$

and $\widehat{HF}(T, \mathbf{a}_T, \mathfrak{h}_T(\mathbf{a}_T))$ is generated by the class of $\{\widetilde{x}_{2g+1}, \widetilde{x}_{2g+2}\}$. Since $\mathbf{y} \cup \{\widetilde{x}_{2g+1}, \widetilde{x}_{2g+2}\}$ is homologous to $\mathbf{y} \cup \{x_{2g+1}, x_{2g+2}\}$ because of the intersection points between \widetilde{a}_i and $\widetilde{\mathfrak{h}}(\widetilde{a}_i)$ contained in $\text{int}(P)$, the lemma follows. \square

Lemma 4.8.4. \mathfrak{T} induces an isomorphism in homology.

Proof. By an argument similar to the proof of Lemma [15, Lemma 5.2.1],

$$\Phi_{(\widetilde{S}, \widetilde{\mathfrak{h}})}(\mathbf{y} \cup \{\widetilde{x}_{2g+1}, \widetilde{x}_{2g+2}\}) = e_3^2 \Phi_{(S, \mathfrak{h})}(\mathbf{y}),$$

and therefore there is a commutative diagram

$$\begin{array}{ccc} \widehat{CF}(S, \mathbf{a}, \mathfrak{h}(\mathbf{a})) & \xrightarrow{\mathfrak{S}} & \widehat{CF}(\widetilde{S}, \widetilde{\mathbf{a}}, \widetilde{\mathfrak{h}}(\widetilde{\mathbf{a}})) \\ \Phi_{(S, \mathfrak{h})} \downarrow & & \downarrow \Phi_{(\widetilde{S}, \widetilde{\mathfrak{h}})} \\ PFC_{2g}(N) & \xrightarrow{\mathfrak{T}} & PFC_{2g+2}(\widetilde{N}). \end{array}$$

Then Theorem 4.7.1 and Lemma 4.8.3 imply that \mathfrak{T} induces an isomorphism in homology. \square

Let $\iota: PFC_{2g+2}(N) \rightarrow PFC_{2g+2}(\widetilde{N})$ be the inclusion of complexes induced by the inclusion $N \subset \widetilde{N}$.

Lemma 4.8.5. *The inclusion ι is a chain map and induces an injective map $\iota_*: PFH_{2g+2}(N) \rightarrow PFH_{2g+2}(\widetilde{N})$.*

Proof. Both claims are a consequence of [15, Lemma 5.2.1], stating that each irreducible component of a holomorphic curve in $\mathbb{R} \times \widetilde{N}$ is contained in one of $\mathbb{R} \times N$, $\mathbb{R} \times N_T$ or $\mathbb{R} \times N_P$. This is a consequence of the blocking lemma [12, Lemma 5.2.3], the trapping lemma [12, Lemma 5.3.2] and Property $(\dagger)_{2g+2}$, which helps us control the behaviour of the curves at the ends, and therefore their relative homology classes. \square

Proof of Proposition 4.8.2. Let $\iota: PFC_{2g+2}(N) \rightarrow PFC_{2g+2}(\tilde{N})$ be the inclusion, which is a chain map by [15, Lemma 5.2.1]. We claim that the diagram

$$\begin{array}{ccc} PFH_{2g}(N) & \xrightarrow{\mathfrak{T}_*} & PFH_{2g+2}(\tilde{N}) \\ \downarrow j_* & \nearrow \iota_* & \\ PFC_{2g+2}(N) & & \end{array}$$

commutes. In fact, by Morse-Bott theory, there are holomorphic cylinders from h_{1P} to e and e_3 coming from the unstable manifolds of h_{1P} for the negative gradient flow of f (see Figure 4.9 and [15, Lemma 5.2.2]) and therefore, if γ is a cycle in $PFC_{2g}(N)$, we have $\partial(h_{1P}(e + e_3)\gamma) = e^2\gamma + e_3^2\gamma$.

The claim implies that $\iota_* \circ j_*$ is an isomorphism, and therefore ι_* is surjective. Thus it is invertible by Lemma 4.8.5, and this shows that $j_* = \iota_*^{-1} \circ \mathfrak{T}_*$ is invertible. \square

In view of Lemma 4.8.1 we can repeat the stabilisation argument arbitrarily many times and conclude that the natural map $PFH_{2g}(N) \rightarrow \widehat{PFH}(N, \partial N)$ is an isomorphism. This implies that $\widehat{\Phi}_*$ is an isomorphism and therefore finishes the proof of Theorem 4.1.1.

Bibliography

- [1] M. Atiyah. New invariants of 3- and 4-dimensional manifolds. In *The mathematical heritage of Hermann Weyl (Durham, NC, 1987)*, volume 48 of *Proc. Sympos. Pure Math.*, pages 285–299. Amer. Math. Soc., Providence, RI, 1988.
- [2] M. S. Borman, Y. Eliashberg, and E. Murphy. Existence and classification of overtwisted contact structures in all dimensions. *Acta Math.*, 215(2):281–361, 2015.
- [3] F. Bourgeois. *A Morse-Bott approach to contact homology*. ProQuest LLC, Ann Arbor, MI, 2002. Thesis (Ph.D.)–Stanford University.
- [4] F. Bourgeois, Y. Eliashberg, H. Hofer, K. Wysocki, and E. Zehnder. Compactness results in symplectic field theory. *Geom. Topol.*, 7:799–888, 2003.
- [5] J. Bowden. Exactly fillable contact structures without Stein fillings. *Algebr. Geom. Topol.*, 12(3):1803–1810, 2012.
- [6] B. Chantraine, G. Dimitroglou Rizell, P. Ghiggini, and R. Golovko. Floer theory for Lagrangian cobordisms. Preprint, arXiv:1511.09471. To appear in *J. Diff. Geometry*.
- [7] B. Chantraine, G. Dimitroglou Rizell, P. Ghiggini, and R. Golovko. Geometric generation of the wrapped Fukaya category of Weinstein manifolds and sectors. Preprint, arXiv:1712.09126.
- [8] B. Chantraine, G. Dimitroglou Rizell, P. Ghiggini, and R. Golovko. Floer homology and Lagrangian concordance. In *Proceedings of the Gökova Geometry-Topology Conference 2014*, pages 76–113. Gökova Geometry/Topology Conference (GGT), Gökova, 2015.
- [9] K. Cieliebak and Y. Eliashberg. *From Stein to Weinstein and back*, volume 59 of *American Mathematical Society Colloquium Publications*. American Mathematical Society, Providence, RI, 2012. Symplectic geometry of affine complex manifolds.
- [10] V. Colin. Recollement de variétés de contact tendues. *Bull. Soc. Math. France*, 127(1):43–69, 1999.

- [11] V. Colin. Une infinité de structures de contact tendues sur les variétés toroïdales. *Comment. Math. Helv.*, 76(2):353–372, 2001.
- [12] V. Colin, P. Ghiggini, and K. Honda. Embedded contact homology and open book decompositions. Preprint, arXiv:1008.2734.
- [13] V. Colin, P. Ghiggini, and K. Honda. The equivalence of Heegaard Floer homology and embedded contact homology III: from hat to plus. Preprint, arXiv:1208.1526.
- [14] V. Colin, P. Ghiggini, and K. Honda. The equivalence of Heegaard Floer homology and embedded contact homology via open book decompositions I. Preprint, arXiv:1208.1074.
- [15] V. Colin, P. Ghiggini, and K. Honda. The equivalence of Heegaard Floer homology and embedded contact homology via open book decompositions II. Preprint, arXiv:1208.1077.
- [16] V. Colin, P. Ghiggini, K. Honda, and M. Hutchings. Sutures and contact homology I. *Geom. Topol.*, 15(3):1749–1842, 2011.
- [17] V. Colin, E. Giroux, and K. Honda. Finitude homotopique et isotopique des structures de contact tendues. *Publ. Math. Inst. Hautes Études Sci.*, (109):245–293, 2009.
- [18] F. Ding and H. Geiges. A Legendrian surgery presentation of contact 3-manifolds. *Math. Proc. Cambridge Philos. Soc.*, 136(3):583–598, 2004.
- [19] Y. Eliashberg. Classification of overtwisted contact structures on 3-manifolds. *Invent. Math.*, 98(3):623–637, 1989.
- [20] Y. Eliashberg. Filling by holomorphic discs and its applications. In *Geometry of low-dimensional manifolds, 2 (Durham, 1989)*, pages 45–67. Cambridge Univ. Press, Cambridge, 1990.
- [21] Y. Eliashberg. Unique holomorphically fillable contact structure on the 3-torus. *Internat. Math. Res. Notices*, (2):77–82, 1996.
- [22] Y. Eliashberg. A few remarks about symplectic filling. *Geom. Topol.*, 8:277–293, 2004.
- [23] Y. Eliashberg, A. Givental, and H. Hofer. Introduction to symplectic field theory. *Geom. Funct. Anal.*, (Special Volume, Part II):560–673, 2000. GAFA 2000 (Tel Aviv, 1999).
- [24] Y. Eliashberg and W. Thurston. *Confoliations*, volume 13 of *University Lecture Series*. American Mathematical Society, Providence, RI, 1998.
- [25] J. Etnyre and K. Honda. On the nonexistence of tight contact structures. *Ann. of Math. (2)*, 153(3):749–766, 2001.

- [26] J. Etnyre and K. Honda. Tight contact structures with no symplectic fillings. *Invent. Math.*, 148(3):609–626, 2002.
- [27] A. Floer. An instanton-invariant for 3-manifolds. *Comm. Math. Phys.*, 118(2):215–240, 1988.
- [28] K. Fukaya, Y.-G. Oh, H. Ohta, and K. Ono. *Lagrangian intersection Floer theory: anomaly and obstruction. Part II*, volume 46 of *AMS/IP Studies in Advanced Mathematics*. American Mathematical Society, Providence, RI; International Press, Somerville, MA, 2009.
- [29] D. Gabai. Foliations and the topology of 3-manifolds. *J. Differential Geom.*, 18(3):445–503, 1983.
- [30] D. Gabai. Detecting fibred links in S^3 . *Comment. Math. Helv.*, 61(4):519–555, 1986.
- [31] D. Gabai. Foliations and the topology of 3-manifolds. II. *J. Differential Geom.*, 26(3):461–478, 1987.
- [32] D. Gabai. Foliations and the topology of 3-manifolds. III. *J. Differential Geom.*, 26(3):479–536, 1987.
- [33] S. Ganatra. Symplectic cohomology and duality for the wrapped fukaya category. Preprint, arXiv:1304.7312.
- [34] D. Gay. Four-dimensional symplectic cobordisms containing three-handles. *Geom. Topol.*, 10:1749–1759, 2006.
- [35] H. Geiges. *An introduction to contact topology*, volume 109 of *Cambridge Studies in Advanced Mathematics*. Cambridge University Press, Cambridge, 2008.
- [36] P. Ghiggini. Strongly fillable contact 3-manifolds without Stein fillings. *Geom. Topol.*, 9:1677–1687, 2005.
- [37] P. Ghiggini. Infinitely many universally tight contact manifolds with trivial Ozsváth-Szabó contact invariants. *Geom. Topol.*, 10:335–357, 2006.
- [38] P. Ghiggini. Ozsváth-Szabó invariants and fillability of contact structures. *Math. Z.*, 253(1):159–175, 2006.
- [39] P. Ghiggini. Knot Floer homology detects genus-one fibred knots. *Amer. J. Math.*, 130(5):1151–1169, 2008.
- [40] P. Ghiggini and Honda. Giroux torsion and twisted coefficients. Preprint, arXiv:0804.1568.
- [41] P. Ghiggini, K. Honda, and J Van Horn-Morris. The vanishing of the contact invariant in the presence of torsion. Preprint, arXiv:0706.1602.

- [42] P. Ghiggini, K. Niederkrüger, and C. Wendl. Subcritical contact surgeries and the topology of symplectic fillings. *J. Éc. polytech. Math.*, 3:163–208, 2016.
- [43] P. Ghiggini and S. Schönenberger. On the classification of tight contact structures. In *Topology and Geometry of Manifolds*, volume 71 of *Proceedings of Symposia in Pure Mathematics*, pages 121–151. American Mathematical Society, 2003.
- [44] P. Ghiggini and J. Van Horn-Morris. Tight contact structures on the Brieskorn spheres $-\Sigma(2, 3, 6n-1)$ and contact invariants. *J. Reine Angew. Math.*, 718:1–24, 2016.
- [45] E. Giroux. Convexité en topologie de contact. *Comment. Math. Helv.*, 66(4):637–677, 1991.
- [46] E. Giroux. Une structure de contact, même tendue, est plus ou moins tordue. *Ann. Sci. École Norm. Sup. (4)*, 27(6):697–705, 1994.
- [47] E. Giroux. Une infinité de structures de contact tendues sur une infinité de variétés. *Invent. Math.*, 135(3):789–802, 1999.
- [48] E. Giroux. Structures de contact en dimension trois et bifurcations des feuilletages de surfaces. *Invent. Math.*, 141(3):615–689, 2000.
- [49] E. Giroux. Géométrie de contact: de la dimension trois vers les dimensions supérieures. In *Proceedings of the International Congress of Mathematicians, Vol. II (Beijing, 2002)*, pages 405–414, Beijing, 2002. Higher Ed. Press.
- [50] R. Gompf. Handlebody construction of Stein surfaces. *Ann. of Math. (2)*, 148(2):619–693, 1998.
- [51] M. Gromov. Pseudoholomorphic curves in symplectic manifolds. *Invent. Math.*, 82(2):307–347, 1985.
- [52] A. Hatcher. Notes on Basic 3-Manifold Topology. Book in preparation, available at the URL <http://www.math.cornell.edu/~hatcher/>.
- [53] H. Hofer. Pseudoholomorphic curves in symplectizations with applications to the Weinstein conjecture in dimension three. *Invent. Math.*, 114(3):515–563, 1993.
- [54] K. Honda. On the classification of tight contact structures. I. *Geom. Topol.*, 4:309–368, 2000.
- [55] K. Honda. On the classification of tight contact structures. II. *J. Differential Geom.*, 55(1):83–143, 2000.
- [56] K. Honda, W. Kazez, and G. Matić. Contact structures, sutured Floer homology and TQFT. Preprint, arXiv:0807.2431.

- [57] K. Honda, W. Kazez, and G. Matic. Convex decomposition theory. *Int. Math. Res. Not.*, (2):55–88, 2002.
- [58] K. Honda, W. Kazez, and G. Matic. The contact invariant in sutured Floer homology. *Invent. Math.*, 176(3), 2009.
- [59] K. Honda, W. Kazez, and G. Matic. On the contact class in Heegaard Floer homology. *J. Differential Geom.*, 83(2):289–311, 2009.
- [60] M. Hutchings. An index inequality for embedded pseudoholomorphic curves in symplectizations. *J. Eur. Math. Soc. (JEMS)*, 4(4):313–361, 2002.
- [61] M. Hutchings. The embedded contact homology index revisited. In *New perspectives and challenges in symplectic field theory*, volume 49 of *CRM Proc. Lecture Notes*, pages 263–297. Amer. Math. Soc., Providence, RI, 2009.
- [62] M. Hutchings and M. Sullivan. Rounding corners of polygons and the embedded contact homology of T^3 . *Geom. Topol.*, 10:169–266, 2006.
- [63] M. Hutchings and C. H. Taubes. Gluing pseudoholomorphic curves along branched covered cylinders. I. *J. Symplectic Geom.*, 5(1):43–137, 2007.
- [64] M. Hutchings and C. H. Taubes. Gluing pseudoholomorphic curves along branched covered cylinders. II. *J. Symplectic Geom.*, 7(1):29–133, 2009.
- [65] M. Hutchings and C. H. Taubes. The Weinstein conjecture for stable Hamiltonian structures. *Geom. Topol.*, 13(2):901–941, 2009.
- [66] M. Hutchings and C. H. Taubes. Proof of the Arnold chord conjecture in three dimensions 1. *Math. Res. Lett.*, 18(2):295–313, 2011.
- [67] M. Hutchings and C. H. Taubes. Proof of the Arnold chord conjecture in three dimensions, II. *Geom. Topol.*, 17(5):2601–2688, 2013.
- [68] E.-N. Ionel and T. H. Parker. Relative Gromov-Witten invariants. *Ann. of Math. (2)*, 157(1):45–96, 2003.
- [69] A. Juhász. Holomorphic discs and sutured manifolds. *Algebr. Geom. Topol.*, 6:1429–1457, 2006.
- [70] A. Juhász. Floer homology and surface decompositions. *Geom. Topol.*, 12(1):299–350, 2008.
- [71] A. Juhász, D. Thurston, and I. Zemke. Naturality and mapping class groups in Heegaard Floer homology. Preprint, arXiv:1210.4996.
- [72] R. Kirby. Problems in low dimensional manifold theory. In *Algebraic and geometric topology (Proc. Sympos. Pure Math., Stanford Univ., Stanford, Calif., 1976), Part 2*, Proc. Sympos. Pure Math., XXXII, pages 273–312. Amer. Math. Soc., Providence, R.I., 1978.

- [73] P. Kronheimer and T. Mrowka. *Monopoles and three-manifolds*, volume 10 of *New Mathematical Monographs*. Cambridge University Press, Cambridge, 2007.
- [74] Ç Kutluhan, Y.-J. Lee, and H. C Taubes. *HF = HM I: Heegaard Floer homology and Seiberg–Witten floer homology*. Preprint, arXiv:1007.1979.
- [75] Ç Kutluhan, Y.-J. Lee, and H. C Taubes. *HF = HM II: Reeb orbits and holomorphic curves for the ech/Heegaard Floer correspondence*. Preprint, arXiv:1008.1595.
- [76] Ç Kutluhan, Y.-J. Lee, and H. C Taubes. *HF = HM III: Holomorphic curves and the differential for the ech/Heegaard Floer correspondence*. Preprint, arXiv:1010.3456.
- [77] Ç Kutluhan, Y.-J. Lee, and H. C Taubes. *HF = HM IV: The Seiberg-Witten Floer homology and ech correspondence*. Preprint, arXiv:1107.2297.
- [78] Ç Kutluhan, Y.-J. Lee, and H. C Taubes. *HF = HM V: Seiberg-Witten-Floer homology and handle addition*. Preprint, arXiv:1204.0115.
- [79] Ç. Kutluhan, S. Sivek, and H. C. Taubes. *Sutured ECH is a natural invariant*. Preprint, arXiv:1312.3600.
- [80] R. Lipshitz. *A cylindrical reformulation of Heegaard Floer homology*. *Geom. Topol.*, 10:955–1096, 2006.
- [81] R. Lipshitz. *A cylindrical reformulation of Heegaard Floer homology*. *Geom. Topol.*, 10:955–1096, 2006.
- [82] P. Lisca and G. Matić. *Tight contact structures and Seiberg-Witten invariants*. *Invent. Math.*, 129(3):509–525, 1997.
- [83] P. Lisca and A. Stipsicz. *Seifert fibered contact three-manifolds via surgery*. *Algebr. Geom. Topol.*, 4:199–217, 2004.
- [84] P. Lisca and A. Stipsicz. *Contact Ozsváth-Szabó invariants and Giroux torsion*. *Algebr. Geom. Topol.*, 7:1275–1296, 2007.
- [85] R. Lutz. *Sur quelques propriétés des formes différentielles en dimension trois*. Thèse, Strasbourg (1971).
- [86] J. Martinet. *Formes de contact sur les variétés de dimension 3*. In *Proceedings of Liverpool Singularities Symposium, II (1969/1970)*, pages 142–163. Lecture Notes in Math., Vol. 209. Springer, Berlin, 1971.
- [87] D. McDuff and D. Salamon. *J-holomorphic curves and symplectic topology*, volume 52 of *American Mathematical Society Colloquium Publications*. American Mathematical Society, Providence, RI, second edition, 2012.

- [88] Y. Ni. Knot Floer homology detects fibred knots. *Invent. Math.*, 170(3):577–608, 2007.
- [89] P. Ozsváth and Z. Szabó. Absolutely graded Floer homologies and intersection forms for four-manifolds with boundary. *Adv. Math.*, 173(2):179–261, 2003.
- [90] P. Ozsváth and Z. Szabó. Holomorphic disks and genus bounds. *Geom. Topol.*, 8:311–334, 2004.
- [91] P. Ozsváth and Z. Szabó. Holomorphic disks and knot invariants. *Adv. Math.*, 186(1):58–116, 2004.
- [92] P. Ozsváth and Z. Szabó. Holomorphic disks and three-manifold invariants: properties and applications. *Ann. of Math. (2)*, 159(3):1159–1245, 2004.
- [93] P. Ozsváth and Z. Szabó. Holomorphic disks and topological invariants for closed three-manifolds. *Ann. of Math. (2)*, 159(3):1027–1158, 2004.
- [94] P. Ozsváth and Z. Szabó. Holomorphic triangle invariants and the topology of symplectic four-manifolds. *Duke Math. J.*, 121(1):1–34, 2004.
- [95] P. Ozsváth and Z. Szabó. On Heegaard Floer homology and Seifert fibered surgeries. In *Proceedings of the Casson Fest*, volume 7 of *Geom. Topol. Monogr.*, pages 181–203. Geom. Topol. Publ., Coventry, 2004.
- [96] P. Ozsváth and Z. Szabó. Heegaard Floer homology and contact structures. *Duke Math. J.*, 129(1):39–61, 2005.
- [97] P. Ozsváth and Z. Szabó. Holomorphic triangles and invariants for smooth four-manifolds. *Adv. Math.*, 202(2):326–400, 2006.
- [98] Peter Ozsváth and Zoltán Szabó. The Dehn surgery characterization of the trefoil and the figure eight knot. *J. Symplectic Geom.*, 17(1):251–265, 2019.
- [99] O. Plamenevskaya. Contact structures with distinct Heegaard Floer invariants. *Math. Res. Lett.*, 11(4):547–561, 2004.
- [100] V. Gripp Barros Ramos. Absolute gradings on ECH and Heegaard Floer homology. *Quantum Topol.*, 9(2):207–228, 2018.
- [101] J. Rasmussen. Floer homology and knot complements. Ph.D. thesis, Harvard University, ArXiv:math.GT/0306378.
- [102] P. Seidel. *Fukaya categories and Picard-Lefschetz theory*. Zurich Lectures in Advanced Mathematics. European Mathematical Society (EMS), Zürich, 2008.

- [103] C. H. Taubes. *Seiberg Witten and Gromov invariants for symplectic 4-manifolds*, volume 2 of *First International Press Lecture Series*. International Press, Somerville, MA, 2000. Edited by Richard Wentworth.
- [104] C. H. Taubes. Embedded contact homology and Seiberg-Witten Floer cohomology I. *Geom. Topol.*, 14(5):2497–2581, 2010.
- [105] C. H. Taubes. Embedded contact homology and Seiberg-Witten Floer cohomology II. *Geom. Topol.*, 14(5):2583–2720, 2010.
- [106] C. H. Taubes. Embedded contact homology and Seiberg-Witten Floer cohomology III. *Geom. Topol.*, 14(5):2721–2817, 2010.
- [107] C. H. Taubes. Embedded contact homology and Seiberg-Witten Floer cohomology IV. *Geom. Topol.*, 14(5):2819–2960, 2010.
- [108] C. H. Taubes. Embedded contact homology and Seiberg-Witten Floer cohomology V. *Geom. Topol.*, 14(5):2961–3000, 2010.
- [109] Clifford Henry Taubes. The Seiberg-Witten equations and the Weinstein conjecture. *Geom. Topol.*, 11:2117–2202, 2007.
- [110] W. Thurston and H. Winkelnkemper. On the existence of contact forms. *Proc. Amer. Math. Soc.*, 52:345–347, 1975.
- [111] V. Turaev. Torsion invariants of Spin^c -structures on 3-manifolds. *Math. Res. Lett.*, 4(5):679–695, 1997.
- [112] C. Wendl. Finite energy foliations on overtwisted contact manifolds. *Geom. Topol.*, 12(1):531–616, 2008.
- [113] X. Zhang. On property I for knots in S^3 . *Trans. Amer. Math. Soc.*, 339(2):643–657, 1993.