



HAL
open science

Intelligent routing protocols in Vehicular Ad hoc Networks

Omar Sami Oubbati

► **To cite this version:**

Omar Sami Oubbati. Intelligent routing protocols in Vehicular Ad hoc Networks. Networking and Internet Architecture [cs.NI]. Université de Laghouat, Algérie, 2018. English. NNT : . tel-02795743

HAL Id: tel-02795743

<https://hal.science/tel-02795743>

Submitted on 5 Jun 2020

HAL is a multi-disciplinary open access archive for the deposit and dissemination of scientific research documents, whether they are published or not. The documents may come from teaching and research institutions in France or abroad, or from public or private research centers.

L'archive ouverte pluridisciplinaire **HAL**, est destinée au dépôt et à la diffusion de documents scientifiques de niveau recherche, publiés ou non, émanant des établissements d'enseignement et de recherche français ou étrangers, des laboratoires publics ou privés.

PEOPLE'S DEMOCRATIC REPUBLIC OF ALGERIA
MINISTRY OF HIGHER EDUCATION AND SCIENTIFIC RESEARCH
AMAR TELIDJI UNIVERSITY OF LAGHOUAT
FACULTY OF SCIENCES



DOCTORAL THESIS

Presented to obtain the Doctorate of Science diploma

SPECIALITY : COMPUTER SCIENCE

Laboratory of Computer Science and Mathematics

INTELLIGENT ROUTING PROTOCOLS IN VEHICULAR AD HOC NETWORKS

Author:

Omar Sami Oubbati

**Publicly defended in 26th February, 2018 in front of a jury committee
composed of:**

M. Youcef Ouinten	Professor	UATL	President of the jury
M. Fayçal Bouyakoub	Professor	USTHB	Examiner
M. Salim Bitam	Professor	UMKB	Examiner
M. Nasreddine Lagraa	Professor	UATL	Examiner
M. Abderrahmane Lakas	Professor	UAEU	Advisor
M. Mohamed Bachir Yagoubi	Professor	UATL	Co-Advisor

Acknowledgments

First of all, my thanks to almighty Allah for giving me the will, patience, and health to develop this work.

I would like to express my deepest gratitude and sincere thanks to my supervisors:

Prof. Abderrahmane Lakas, for the trust he has placed in me by accepting the supervision of this doctoral thesis. It is in fact thanks to his invaluable help and priceless advices he have always given me, and his professionalism of scientific sharing that this dissertation has been completed in an exceptional way. I also thank him for his permanent availability and responsiveness to my requests and for giving his time and effort without reservation. His guidance and intelligence made this project a model of success and a source of motivation and kept my PhD work in the right direction. I never forget his strong support and assistance during my different internships abroad (UAE, France, and Germany). Successful completion of this thesis would not have been possible without his invaluable insights and comments on my work. I will always be grateful to him.

Prof. Mohamed Bachir Yagoubi, for the follow-up, the supervision, and the support that he gave me throughout the development of this thesis. His numerous advices, valuable recommendations, scientific qualities, and continuous encouragement were undoubtedly decisive to carry out my research work. Also, I would like to thank him for facilitating all the administrative procedures throughout the years of studies.

Many thanks to Prof. Mesut Güneş and his laboratory staff for their support and the excellent enjoyable ambiance.

A very special thank you to Prof. Youcef Ouinten, a professor at the University of Laghouat who has done me the honor of chairing this jury. My sincere thanks also go to the jury members: Prof. Fayçal Bouyakoub, a professor at USTHB, Prof. Salim Bitam, A professor at the University of Biskra, and Prof. Nasreddine Lagraa, A professor at the University of Laghouat, who accepted to carry out the evaluation of this work, in spite of their heavy and exalting responsibilities.

Finally, I keep a special place for all my teachers and colleagues. I sincerely would like to express my deep gratitude to them and especially to Prof. Nasreddine Lagraa and all my colleagues at the LIM laboratory for the beneficial discussions, research collaborations, and continuous exchange of knowledge.

Omar Sami Oubbati

June 5, 2020

For my family . . .

Logic will get you from A to B. Imagination will take you everywhere.
Albert Einstein

List of publications

International Journals

1. O. S. Oubbati, A. Lakas, F. Zhou, M. Güneş, N. Lagraa, and M. B. Yagoubi, “Intelligent UAV-Assisted Routing Protocol for Urban VANETs,” *Computer communications*, vol. 107, pp. 93–111, 2017. (**impact factor: 3.338**)
2. O. S. Oubbati, A. Lakas, F. Zhou, M. Güneş, and M. B. Yagoubi, “A Survey on Position-based Routing Protocols for Flying Ad hoc Networks (FANETs),” *Vehicular communications*, 2017. (**impact factor: 5.108**)
3. O. S. Oubbati, A. Lakas, and M. B. Yagoubi, “On-Demand Routing for Urban VANETs using Cooperating UAVs,” *Ad hoc networks*, (***Under review.***) (**impact factor: 3.047**)

International Conferences

1. O. S. Oubbati, A. Lakas, M. Güneş, F. Zhou, and M. B. Yagoubi, “UAV-Assisted Reactive Routing for Urban VANETs,” in *Proceedings of the 32nd ACM SIGAPP Symposium On Applied Computing (SAC)*, 2017. pp. 1–3.
2. O. S. Oubbati, A. Lakas, N. Lagraa, and M. B. Yagoubi, “UVAR: An intersection UAV-Assisted VANET routing protocol,” in *Proceedings of the IEEE Wireless Communications and Networking Conference (WCNC)*, 2016.
3. O. S. Oubbati, A. Lakas, N. Lagraa, and M. B. Yagoubi, “CRUV: Connectivity-based traffic density aware routing using UAVs for VANETs,” in *Proceedings of the IEEE International Conference on Connected Vehicles and Expo (ICCVE)*, 2015.
4. O. S. Oubbati, A. Lakas, N. Lagraa, and M. B. Yagoubi, “ETAR: Efficient traffic light aware routing protocol for vehicular networks,” in *Proceedings of the IEEE International Wireless Communications and Mobile Computing Conference (IWCMC)*, 2015, pp. 297–301.
5. O. S. Oubbati, N. Lagraa, A. Lakas, M. B. Yagoubi, “IRTIV: Intelligent routing protocol using real time traffic information in urban vehicular environment,” in *Proceedings of the 6th International Conference on New Technologies, Mobility and Security (NTMS)*, 2014, pp. 1–4.

Abstract

Vehicular ad hoc networks (VANETs) are considered as a fundamental technology to manage the intelligent transportation systems (ITS), which are a set of innovative technologies enabling a wide range of road traffic management and safety services. VANETs have gone from a simple curiosity stage to a true interest from both the point of view of the automotive industry and the operators of networks and services. Indeed, these networks are an emerging class of wireless networks, allowing data exchange between vehicles or between vehicles and infrastructures placed along the roads and provide new technologies to improve the safety and efficiency of road transport. Following this same vision, commercial Unmanned Aerial Vehicles (UAVs) or what are commonly referred to as drones, have been increased significantly over urban areas because of their affordable prices and the multiplication of different useful applications in which the UAVs can be the suitable support during their functioning. Consequently, we can consider vehicles and UAVs as two different entities, with different properties, belonging to the same area, and can form a single network dealing with various common constraints over this kind of environment.

In this context, in this thesis, we are interested in the process of inter-vehicle communications in urban areas. Our aim is to propose a set of routing solutions meeting the constraints and difficulties of such environments based on the cooperation of UAVs with VANETs. Firstly, we propose a routing scheme which relies on selecting, at each moment and ahead of time, the most connected road segments towards the target destinations based on the Hello packets exchanged periodically between vehicles with the assistance of UAVs acting as supervisors. Secondly, we propose a routing scheme which consists of two routing components, the first supports the wireless communications on the ground exclusively between vehicles, while the second operates in the sky in order to support the communications exclusively between UAVs. Finally, we introduce a reactive-based routing approach based on a prediction technique to calculate the expiration time of each discovered routing path between communicating entities.

Our proposed approaches are promising candidates for routing in VANETs, which can realize reliable and efficient end-to-end communications between nodes in urban areas. On the other hand, the performances of our approaches are evaluated based on a series of simulations, and its merits and pitfalls are well discussed.

Keywords: Routing protocols, UAVs, Urban area, Connectivity, VANETs.

Résumé

Les réseaux véhiculaires (VANETs) sont considérés comme une technologie fondamentale pour gérer les systèmes de transport intelligents (ITS), qui sont un ensemble de technologies innovantes permettant une large gamme de services de gestion de la circulation routière et de sécurité. Les VANETs sont passés d'une simple étape de curiosité à un véritable intérêt tant du point de vue de l'industrie automobile que des opérateurs de réseaux et de services. En effet, ces réseaux constituent une classe émergente des réseaux sans fil, permettant l'échange de données entre les entités communicantes de la route et fournissent de nouvelles technologies afin d'améliorer la sécurité et l'efficacité du transport routier. Suivant cette même vision, les véhicules aériens sans pilote commerciaux (UAVs) ou ce que l'on appelle communément des *drones* ont été largement déployés dans les zones urbaines en raison de leurs prix abordables et de la multiplication des applications utiles dans lesquelles les drones peuvent être le support approprié pour leur fonctionnement correct. Par conséquent, les véhicules et les UAVs sont considérés comme deux entités différentes, ayant des propriétés différentes, appartenant à un même environnement, et pouvant former un seul réseau traitant de diverses contraintes communes sur ce type d'environnement.

Dans cette thèse, notre objectif est de proposer un ensemble de solutions de routage dans les VANETs répondant aux contraintes et aux difficultés des environnements urbains. Dans un premier temps, nous proposons un protocole de routage qui consiste à sélectionner préalablement et de façon permanente les segments de route les plus connectés vers les destinations cibles à l'aide des paquets Hello échangés périodiquement entre véhicules où les drones peuvent agir comme des superviseurs. Ensuite, nous proposons un protocole de routage qui intègre deux composants de routage différents, le premier supporte les communications sans fil au sol exclusivement entre les véhicules et le second opère dans le ciel afin de supporter les communications exclusivement entre les drones. Pour finir, nous introduisons une approche de routage réactive basée sur une technique de prédiction pour calculer le temps d'expiration de chaque chemin de routage découvert entre les entités communicantes.

Nos protocoles proposés peuvent être considérés comme efficace qui permettent de réaliser des communications de bout en bout fiables et efficaces entre les noeuds. En revanche, les performances de nos approches sont évaluées sur la base d'une série de simulations, dont les avantages et les inconvénients sont bien discutés.

Mots-clés: Protocoles de routage, UAVs, Zone urbaine, Connectivité, VANETs.

Contents

Abstract	viii
Contents	xii
List of Tables	xiii
List of Figures	xvi
List of Abbreviations	xvii
1 Introduction	1
1.1 Preamble	1
1.2 Issues and Challenges	2
1.3 Thesis goals	3
1.4 Thesis contributions and outline	4
2 Background	6
2.1 Introduction	7
2.2 Ad hoc networks	8
2.2.1 Ad hoc networks architecture	9
2.2.2 Ad hoc advantages	9
2.3 Mobile Ad hoc Network (MANET)	10
2.3.1 MANET Architecture	11

2.3.2	MANET characteristics	12
2.3.3	MANET applications	13
2.3.4	Technical issues in MANET	14
2.4	Vehicular Ad hoc Network (VANET)	15
2.4.1	VANET Architecture	16
2.4.2	VANET communication technology	17
2.4.3	VANET characteristics	20
2.4.4	VANET Applications	21
2.4.5	Technical issues in VANET	24
2.5	UAV Ad hoc Network (UAANET)	26
2.5.1	UAANET Architecture	27
2.5.2	Unmanned Aerial Vehicle (UAV)	28
2.5.3	UAANET characteristics	30
2.5.4	UAANET applications	32
2.5.5	Technical issues in UAANET	33
2.6	Conclusion	37
3	Routing in VANETs and UAANETs	38
3.1	Introduction	39
3.2	Routing in VANETs	40
3.3	Routing techniques in VANETs	41
3.4	Routing protocols for VANETs	43
3.5	Topology-based VANET routing protocols	43
3.6	Position-based VANET routing protocols	44
3.6.1	Reactive-based routing protocols	44
3.6.2	Greedy-based routing protocols	46
3.6.3	Delay-tolerant-network-based routing protocols	46

3.7	Comparative study of VANET routing protocols	47
3.8	Routing in UAANETs	49
3.9	Routing techniques in UAANETs	51
3.10	Routing protocols for UAANETs	53
3.11	Topology-based UAANET routing protocols	53
3.12	Position-based UAANET routing protocols	54
3.12.1	Reactive-based routing protocols	54
3.12.2	Greedy-based routing protocols	56
3.12.3	Delay-tolerant-network-based routing protocols	58
3.12.4	Heterogeneous routing protocols	60
3.13	Comparative study of UAANET routing protocols	61
3.14	UAANET-to-VANET communications	66
3.15	Conclusion	67
4	CRUV–Connectivity-based Traffic Density Aware Routing using UAVs for VANETs	68
4.1	Introduction	68
4.2	Assumptions	69
4.3	System model	70
4.4	Scoring system	72
4.4.1	Hello packet format	72
4.4.2	Score calculation	73
4.5	Path selection	76
4.6	Performance Evaluation	78
4.6.1	Simulation Model	79
4.6.2	Evaluation metrics	80
4.6.3	Results Analysis	81

4.7	Conclusion	84
5	UVAR-UAV-Assisted VANET Routing Protocol	85
5.1	Introduction	86
5.2	Assumptions	87
5.3	System model	88
5.4	UVAR-G	89
5.4.1	Traffic density estimation	89
5.4.2	Connectivity detection	91
5.4.3	Segment selection	93
5.5	UVAR-S	97
5.5.1	Discovery process	98
5.5.2	Routing decision process	99
5.5.3	Recovery process	101
5.6	Performance evaluations	103
5.7	Results analysis	104
5.7.1	Average delivery ratio	105
5.7.2	Average delay	107
5.7.3	Overhead	109
5.7.4	Average number of hops	109
5.8	Conclusion	113
6	UAV-Assisted Reactive Routing for Urban VANETs	114
6.1	Introduction	115
6.2	Assumptions	116
6.3	Identification of fixed zones	118
6.4	Discovery phase	119

6.4.1	The route request (RREQ) packet format	119
6.4.2	Prediction of the path expiration	120
6.4.3	Principle of the flooding	123
6.5	Selection phase	126
6.5.1	Scoring calculation	126
6.5.2	The route reply (RREP) packet format	129
6.6	Data delivery phase	132
6.7	Maintenance phase	133
6.8	Evaluation	136
6.8.1	Results analysis	137
6.8.2	Packet delivery ratio (PDR)	137
6.8.3	End-to-End delay (EED)	139
6.8.4	Overhead (OH)	141
6.8.5	Average number of hops (HOP)	143
6.9	Conclusion	145
7	Conclusion	146
7.1	Overview of the contribution	146
7.2	Limitations and possible improvements	148
7.3	Future directions	149

List of Tables

2.1	Parameter settings for different application categories in IEEE 802.11p [1, 2].	20
2.2	Difference between UAANETs, VANETs, MANETs.	32
2.3	Comparison of potential scenarios for UAANET	33
3.1	Comparative study between routing protocols.	48
3.2	UAANET position-based routing protocols (comparative study).	65
4.1	Simulation parameters	79
5.1	Comparative study between our works.	86
5.2	Table of density of the segment 1.	90
5.3	Sorted table of density.	91
5.4	Sorted table of density (scenario 2).	92
5.5	Discovered paths.	100
5.6	Alternative path.	102
5.7	Simulation parameters.	104
6.1	Discovered paths.	128
6.2	Simulation parameters.	136

List of Figures

2.1	Ad hoc networks subclasses.	7
2.2	Scenario for using an ad hoc network.	8
2.3	Mobile Ad hoc Network.	11
2.4	Main architecture of VANETs.	16
2.5	Wave architecture [1, 2].	18
2.6	ITS/DSRC channel plan [1, 2].	19
2.7	Main applications in VANETs.	22
2.8	UAANET Transmission modes.	26
2.9	Wireless communications between UAANET nodes.	27
2.10	Classification of UAVs.	28
2.11	UAV types.	29
3.1	Main VANET routing techniques.	42
3.2	Toxonomy of VANET routing protocols.	43
3.3	UAANETs subclass.	49
3.4	Main UAANET routing techniques.	50
3.5	Toxonomy of UAANET routing protocols.	52
3.6	UAV-to-VANETs communications.	66
4.1	Communication architecture of CRUV.	71
4.2	CRUV states.	71

4.3	Additional fields in the Hello packets.	72
4.4	The score's calculation.	73
4.5	The Hello message broadcasted by the vehicle A.	74
4.6	Disconnected road segment.	75
4.7	The Hello message broadcasted by the vehicle C.	75
4.8	Hello message exchange.	77
4.9	Path Selection.	77
4.10	Simulation area.	79
4.11	Packets delivery ratio vs. vehicle density	82
4.12	End-to-End delay vs. vehicle density	82
4.13	Average number of hops vs. vehicle density	83
4.14	Overhead vs. vehicle density	83
5.1	Overview of the assumed scenario.	87
5.2	Communication architecture of UVAR.	88
5.3	Traffic density estimation.	90
5.4	Sparsely connected segment.	93
5.5	D_w calculation scenario.	95
5.6	Discovery process of UVAR-S.	97
5.7	The Route Request (RREQ) packet format.	99
5.8	The Route Reply (RREP) format.	100
5.9	Recovery process.	101
5.10	Network topology.	104
5.11	Packet Delivery Ratio vs. Density of nodes (Vehicles/UAVs).	106
5.12	End-to-End Delay vs. Density of nodes (Vehicles/UAVs).	108
5.13	Control Overhead vs. Density of nodes (Vehicles/UAVs).	110
5.14	Average number of hops vs. Density of nodes (Vehicles/UAVs).	112

6.1	Network topology.	117
6.2	Phase of the identification of fixed zones.	118
6.3	Route Request (RREQ) Format.	120
6.4	Path expiration calculation.	121
6.5	Principle of functioning of the discovery phase.	122
6.6	Routing table of the <i>vehicle</i> ₁	123
6.7	Routing tables in crucial points during the flooding process.	124
6.8	Routing table of the destination <i>gateway</i> ₅	125
6.9	Route Reply (RREP) Format.	129
6.10	Routing tables in crucial points during the selection phase.	130
6.11	Routing table of the source node at the selection phase.	132
6.12	Data packet Format.	132
6.13	Recovered path failure.	134
6.14	Another Recovered path failure.	135
6.15	Map of the simulated area in Laghouat, Algeria (N 33°47' 51.5" E 2°51' 58.9").	136
6.16	Packet Delivery Ratio vs. Density of nodes (Vehicles/UAVs).	138
6.17	End-to-End Delay vs. Density of nodes (Vehicles/UAVs).	140
6.18	Control Overhead vs. Density of nodes (Vehicles/UAVs).	142
6.19	Average number of hops vs. Density of nodes (Vehicles/UAVs).	144

Abbreviations

AGP	A nchor G eography based routing P rotocol
CRUV	C onnectivity-based T raffic D ensity A ware R outing using U AVs for V ANETs
DTN	D elay T olerant N etwork
EED	E nd-to- E nd D elay
ETAR	E fficient T raffic L ight A ware R outing P rotocol
GLS	G rid L ocation S ervice
GPCR	G reedy P erimeter C oordinator R outing
GPS	G lobal P ositioning S ystem
GSM	G lobal S ystem for M obile C ommunication
GSR	G eographic S ource R outing
GyTAR	G reedy T raffic A ware R outing
IRTIV	I ntelligent R outing P rotocol using real-time T raffic I nformation V ANETs
ITS	I ntelligent T ransporation S ystem
MAC	M edium A ccess C ontrol
MANET	M obile A d hoc N ETwork
MURU	M Ulti R outing protocol for U rban V ANETs
OBU	O n B oard U nit
PDR	P acket D elivery R atio
PE	P ath E xpiration
QoS	Q uality of S ervice
RBVT	R oad B ased using V ehicular T raffic R outing
RERR	R oute E RRor
RREP	R oute R EPlay
RREQ	R oute R EQuest
RSU	R oad S ide U nit
SN	S equene N umber
STDMA	S elf-organized T ime- D ivision M ultiple A ccess
SUMO	S imulation for U rban M Obility
UAANET	U AV A d hoc N ETwork
UAV	U nmanned A erial V ehicle
UVAR	U AV-assisted V ANET R outing protocol
VANET	V ehicular A d hoc N ETwork
WAVE	W ireless A ccess in V ehicular E nvironments
WSN	W ireless S ensor N etwork

Chapter 1

Introduction

Contents

1.1 Preamble	1
1.2 Issues and Challenges	2
1.3 Thesis goals	3
1.4 Thesis contributions and outline	4

1.1 Preamble

For many years now, wireless networks have been an integral part of the daily lives of businesses, individuals, industrial corporations, and other organizations. Wireless networks represent one of the most important building block of present and future ubiquitous intelligent systems. Indeed, in the near future, computers, sensors, chips, digital networks, and other electronic systems will participate in the democratization of ubiquitous computing. The goal of this concept is to establish "*Intelligent*" environments that offer to their users a multitude of highly available services and applications (*e.g.*, Intelligent Transportation Systems, Smart Home, Medical Assistance, Surveillance, *etc.*) in which their complexity of implementation is invisible to these same users.

A typical example of these applications is the Intelligent Transportation Systems (ITS), which received immense attention during the last few decades [3, 4]. Among the main objectives of ITS. First, improving the comfort of the drivers and passengers by providing a multitude of information services making commuting a pleasant experience. Second, enhancing the road safety by providing a high level of travel security. The success of these two objectives mainly relies on the key part of ITS, which is VANETs considered as a fundamental technology supporting road-safety as well as comfort applications. VANETs consist of a set of vehicles and road-side-units

(RSUs), which can communicate with each other and exchange data [5]. Such communication relies on the use of a wireless on board unit (OBU), which allows a vehicle to connect to other vehicles in its neighborhood and exchange information pertaining to the travelling, road traffic, and road condition. Vehicles may also exchange information with an RSU. Vehicle-to-Vehicle communication is referred to as V2V and vehicle-to-RSU communication is referred to as V2R. As an ad hoc network, a vehicular network is characterized by its highly dynamic topology due to the high mobility and the unpredictable direction changes of vehicles causing several failures on the communication links.

An effective VANET requires that vehicles and RSUs take into account two performance factors in the case of exchanging data: (i) robust delivery and (ii) end-to-end delay. The robust delivery implies efficient techniques to maintain the constant connectivity between the communicating entities. While for the end-to-end delay, a variety of methods has to be followed, which all aim to minimize the distance of the communication links transited by data packets while ensuring a minimum of packet losses and avoiding obstructions which can distort the data transmission. The unique characteristics of VANETs have to be respected to successfully reach a near-optimal performance.

1.2 Issues and Challenges

The applications based on vehicular communications require in most cases reliability and real-time of communications, and in some cases, minimum quality of service, but this contrasts sharply with the nature of vehicular networks. Indeed, the high mobility, the density of vehicles, and the extent of the areas to be covered, make the topology of VANETs highly dynamic and affect the quality of the connections between vehicles and make them unstable. These constraints become more serious when the vehicles are deployed in urban environments, where the high mobility increases due to the unpredictable direction changes of vehicles. In addition, sometimes direct wireless communications cannot be established between vehicles located on different streets due to the presence of obstacles (*e.g.*, high-rise buildings), even though the distances are smaller than the transmission ranges of vehicles.

Efficient methods of delivering data between vehicles are required to overcome these challenges, while taking into consideration the unpredictable movements of vehicles and the frequent change of the topology. These methods should be in the form of routing protocols, ensuring a reliable and secure data delivery between vehicles [6]. A routing is needed when two communicating vehicles (*i.e.*, source and destination) are not within the radio range of each other where a multi-hop communication has to be ensured through intermediate vehicles participating in the construction of the communication path (or routing path) connecting the two vehicles. The routing path among vehicles may not be ensured all time due to the high mobility of vehicles. So

finding a shortest end-to-end path is very difficult, especially in urban areas because of the vehicles mobility pattern which is constrained by obstacles and preexisting roads. Several routing solutions have been developed in the literature, which all aimed to provide successful routing of data packets to their target destination with a reduced delay. Also, they tried to overcome the frequent network disconnections by finding suitable routing paths providing a high degree of connectivity. However, in the best of our knowledge, a great majority of them disregard existing obstacles that can adversely impact the quality of data routing. Moreover, they do not take into account the real distribution of vehicles and the degree of connectivity, which are crucial in the selection of a suitable path for data delivery.

In urban environments, there are many mobile entities such as trains, cars, airplanes, and even pedestrians, which can be considered as a part of VANETs. All of these entities can serve as relays to support routing in VANETs and forwarding data packets [7]. However, the different relays can be localized in predefined areas, and sometimes cannot participate in relaying data between vehicles. During the last few years, the number of Unmanned Aerial Vehicles (UAVs) that fly over urban roads has been increased significantly. Equipped with communication and navigation accessories, it is only natural to expect a network of UAVs extending VANETs in an integrated way and cooperating with vehicles on the ground. UAVs can be the suitable choice to assist vehicles on the ground during the routing process and improve the reliability of the data delivery by bridging the communication gap whenever it is possible. Furthermore, UAVs can be also considered as the ideal solution to avoid obstacles on the ground and safely relay data packets in the sky to their target destinations.

1.3 Thesis goals

The cooperation in ad hoc mode between UAVs and existing VANETs on the ground can be beneficial to address the different issues mentioned above, which are often caused by the high mobility of nodes and obstructions. This cooperation needs to be organized, flexible, and adaptive to the situation of the network. Being able to have a global vision of the connectivity and traffic information on the ground, UAVs can play a key role both in increasing the data delivery ratio and decreasing the end-to-end delay.

In the present thesis, we investigate the use of UAVs in assisting vehicles on the ground by bridging the communication gap when a disconnection occurs. Indeed, UAVs can place themselves so as to allow relaying data when connectivity between sole vehicles on the ground is not possible. The main idea behind this work is the exploitation of this new heterogeneous wireless communication between vehicles and UAVs in order to enhance the connectivity and minimize the delay of data transition between communicating nodes. Various criteria can be used to select the most

appropriate multi-hop path to deliver the data packets successfully to their destinations, such as the traffic density, degree of connectivity, expiration time, and the real distribution of nodes constituting the path. All these criteria have paved the way to design three important routing schemes for urban VANETs, where each one has its own mechanisms to select the suitable routing path for data transition. In order to achieve the goals of this thesis, we have to address the following research questions:

- Study the concept of ad hoc networks and identify the main types of this kind of networks. Furthermore, provide more details about the adopted architectures, distinguished characteristics, main applications, and technical issues of each kind of ad hoc networks.
- Investigate the use of UAVs and how they can assist vehicles on the ground during the data delivery. Consequently, this requires a deep study of the main routing concepts proposed in the literature, and especially those dedicated for VANETs and UAV ad hoc networks (UAANETs). In addition, try to identify the different challenges and issues encountered by the proposed routing concepts and provide solutions to overcome them.
- Design routing solutions assisted by existing UAVs in the sky in order to improve the routing process in urban VANETs. Moreover, demonstrate the applicability of these approaches according to the nature of both VANETs and UAANETs. Identify the limitations of each proposed approach based on the obtained performance results provided by the simulation tool.
- Highlight the future improvements which can be expected to be made operational in order to enhance the functionality of our proposed routing schemes. This can be an important guidance to researchers willing to contribute to this research area.

1.4 Thesis contributions and outline

The purpose of this research is to study the different routing schemes dedicated for VANETs and UAANETs proposed in the literature. In addition, we explore how UAVs can assist existing VANETs on the ground to enhance the robustness of the routing process by proposing novel routing schemes. This could provide an advantage when UAVs re-establish communication links in case of disconnections due to obstacles and high mobility. To that aim, we explore how UAVs can be used for both delivering data packets and re-linking disconnected road segments. This thesis has the following contributions:

- Our first contribution is to describe in detail related position-based routing protocols for VANETs and UAANETs. Our proposed routing approaches have the

objectives to find the most connected and stable routing path while satisfying delay restrictions and low overhead. Consequently, in order to achieve this purpose, we try to distinguish all advantages and drawbacks of the discussed related routing schemes based on comparative studies.

- Our second contribution is to propose a delay tolerant routing protocol called Connectivity-based Traffic Density Aware Routing using UAVs for VANETs (CRUV) in which the routing process is assisted by UAVs [8]. The robustness of routing paths is estimated based on the traffic density and the connectivity of vehicles within a road segment. This scheme overcomes the presence of obstructions on the ground (*e.g.*, buildings) and the frequent path failures thanks to the use of UAVs as relays.
- Our third contribution is to introduce a novel routing scheme called UAV-Assisted VANET Routing Protocol (UVAR) [9, 10]. This routing approach consists of two routing components, the first one operates on the ground and takes into consideration key parameters such as the real distribution of vehicles and their connectivity in order to find the shortest end-to-end connected path. Furthermore, UAVs are used for the connectivity calculation with the help of their global vision of the overflowed road segments. While the second one, is a reactive-based routing component and operates in the sky supporting exclusively UAVs and can be used in the case when the network is poorly dense and suffers from fragmentations. This reactive component establishes paths on demand, by using an original discovery process in order to find the most connected sequences of UAVs to the target destination.
- Finally, we are interested to include a reactive technique to our new routing concept assisted by UAVs. In this context, the fourth contribution of this thesis consists to design a reactive routing protocol destined for city environments, which is based on the most stable path with a low delay of transmission [11]. Different techniques including a prediction method are used in the discovery process, which aim to improve the delay, overhead, delivery of data, and increase the expiration time of each discovered path.

The rest of the thesis is organized as follows. *Chapter 2* introduces the concept of MANETs, VANETs, and UAANETs. More precisely, we describe the architecture of communications and potential wireless communication technologies for these types of networks. Also, we explore their various characteristics and applications. While *chapter 3* tackles related routing issues for both VANETs and UAANETs, where the main proposed routing protocols are described and global comparative studies are presented. In the *chapters 4, 5, and 6*, we introduce the different functionalities of our routing approaches dedicated for urban VANETs and their performance evaluations. *Chapter 7* concludes this thesis by summarizing its contributions, results, as well as some suggested further research topics.

Chapter 2

Background

Contents

2.1	Introduction	7
2.2	Ad hoc networks	8
2.2.1	Ad hoc networks architecture	9
2.2.2	Ad hoc advantages	9
2.3	Mobile Ad hoc Network (MANET)	10
2.3.1	MANET Architecture	11
2.3.2	MANET characteristics	12
2.3.3	MANET applications	13
2.3.4	Technical issues in MANET	14
2.4	Vehicular Ad hoc Network (VANET)	15
2.4.1	VANET Architecture	16
2.4.2	VANET communication technology	17
2.4.3	VANET characteristics	20
2.4.4	VANET Applications	21
2.4.5	Technical issues in VANET	24
2.5	UAV Ad hoc Network (UAANET)	26
2.5.1	UAANET Architecture	27
2.5.2	Unmanned Aerial Vehicle (UAV)	28
2.5.3	UAANET characteristics	30
2.5.4	UAANET applications	32
2.5.5	Technical issues in UAANET	33
2.6	Conclusion	37

2.1 Introduction

In parallel with the growth of network infrastructures and the multiplication of offered services, the necessities to develop new technologies of communications becomes crucial and sometimes a mandatory condition. With the appearance of new mobile objects such as laptops, smartphones, connected vehicles, *etc.*, classical wired networks are surpassed due to the unpredictable mobility of these mobile objects. Direct wireless communications are essential to exchange crucial information between them establishing a new kind of network called Ad hoc Network. This has given a birth to Mobile Ad hoc Network (MANET), which, in turn, has given a birth to two popular types of mobile ad hoc networks, called Vehicular Ad hoc Network (VANET) and UAV Ad hoc Network (UAANET), which are defined based on the type of mobile nodes in which are composed and the environment where they are deployed (*c.f.*, Figure 2.1). Therefore, some common techniques are shared for data exchange. However, for the right functionality of the forwarding process, these techniques have to be adapted to both mobility models and operating environment, which are specific to each kind of ad hoc networks and quite different from each other.

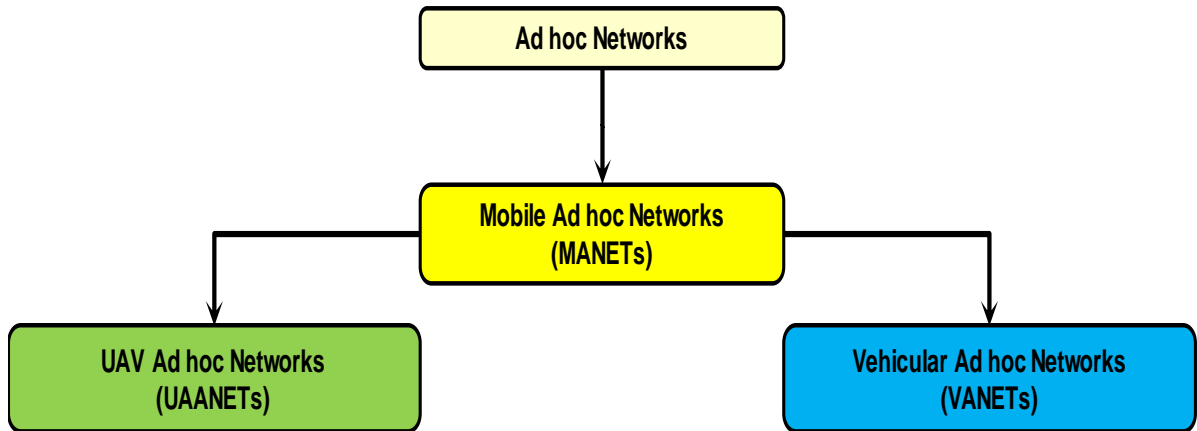

Figure 2.1: Ad hoc networks subclasses.

In this *chapter*, we introduce the concept of ad hoc networks and their main features. Also, we introduce the concept of the three mentioned networks by describing their architectures, their main characteristics, and their technical issues. In addition, for each kind of network, we present the main applications and we identify the objectives and the main challenges toward the different issues.

2.2 Ad hoc networks

Ad hoc networks have appeared during the last century [12, 13]. The entities of this kind of networks are mobile and can exchange data between each other without relying on fixed infrastructures, by establishing direct or multi-hop communications because of the limited range of their wireless interfaces [14]. Ad hoc networks can be deployed quickly and easily by allowing the direct exchange of data packets with mobile stations. In the case when two mobile stations cannot communicate directly because they are not within the communication range of each other, a multi-hop communication is established using the intermediate nodes. In this case, the data packets are transmitted from station to station before reaching the desired destination.

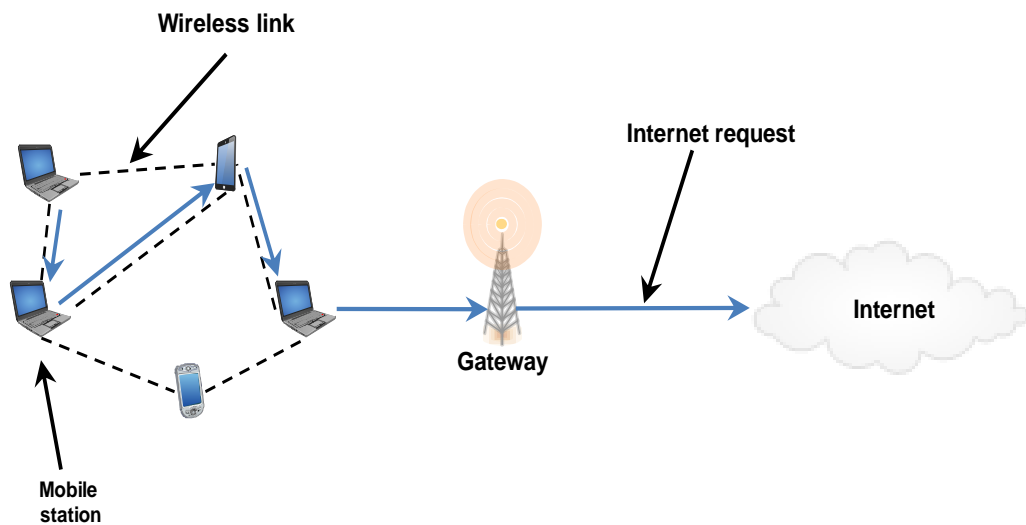

Figure 2.2: Scenario for using an ad hoc network.

Ad hoc networks provide the connectivity with a rapid and low-cost deployment in different application areas. Although they do not require any fixed infrastructure, in practice, ad hoc networks are often linked to the internet through a gateway (*c.f.*, Figure 2.2). This kind of connectivity can extend the network coverage in order to communicate with other nodes localized outside of the infrastructure (Gateway) transmission range. The recent technological progress in computer hardware and the evolution of their use (*e.g.*, consoles providing multi-players games) have led to the emergence of configurations in which all the nodes are equal and participate in the network maintenance. Here, we are talking about non-infrastructure networks or *ad hoc networks*.

2.2.1 Ad hoc networks architecture

In a general case, the wireless networks can be classified into two categories [15]: (i) Infrastructure-based which consists of nodes and access point and (ii) ad hoc-based which is independent of any access point.

In the infrastructure-based architecture, each mobile station does not have a direct link to communicate with another mobile station in the same coverage of a given infrastructure or with another mobile station belongs to a different infrastructure. The role of an infrastructure is to manage the network using the control messages. The messages exchanged between the mobile stations are sent directly to the infrastructure to which they belong, and then, the infrastructure distributes the messages to the desired mobile stations. However, in the case when a mobile station wants to send a message to another mobile station which belongs to another infrastructure, the current infrastructure forwards the message to another infrastructure, in which the destined mobile station belongs using the existing wired connection between each other. After that, the target infrastructure relays the message to the desired mobile station. The main drawback in this kind of architecture, is when there is a failure in the infrastructure, all mobile stations within its coverage cannot perform any communication.

Unlike the infrastructure-based architecture, the ad hoc-based architecture has a different method for delivering messages between mobile stations. For instance, if a mobile station wants to communicate with another mobile station, the message is sent directly to the desired node using the radio signal. In the case when the desired mobile station is located outside the transmission range of the source node, the current node has to hop the message through a succession of nodes to reach the target destination. A set of rules in the form of routing algorithms decide which path is the most suitable for the message delivery. Consequently, ad hoc networks can be a robust way to route messages between mobile stations compared with the infrastructure networks.

2.2.2 Ad hoc advantages

Several causes favor the ad hoc over infrastructure architecture [16, 17]. Among the strengths of an ad hoc deployment is its autonomy from any centralized infrastructure, which can be considered as an advantageous factor to establish such architecture in any difficult situation. Following are the main advantages of ad hoc networks.

- **Distribution mode:** there are some situations where it is useless to build an infrastructure such as in a battlefield, isolated area, mountain, *etc.* An independent network is needed to avoid the expensive costs of installation and maintenance of infrastructures. The user can base only on other users to communicate or to transmit information to another network.

- **Mobility:** sometimes the users need a certain flexibility of movements without relying on a centralized connectivity. For instance, the most popular scenarios where the mobility is required are disaster situations, military actions, rescue operations, *etc.* The current generation of wireless communications consists of mobile users communicating with each other as long as the connectivity is available between them. The rapid deployment of such network is simple to be guaranteed. However, the connectivity has to be ensured while taking into consideration the random mobility of the nodes.
- **Fault tolerance:** the robustness of an ad hoc network is maintained for the duration of the network's functioning. Indeed, in the case when there is a malfunction in a network of infrastructures, the network has to be maintained all-time (*i.e.*, continuous connectivity). However, an ad hoc solution is considered as the best way to deal with such situation where all nodes of the network can act as relays to hop the messages.
- **Affordable cost:** compared with a traditional architecture based on infrastructures, which requires a huge budget for solely its installation. However, the exchanged data can be done using only the existing nodes without relaying through infrastructures, which can save costs while functioning normally.
- **Collaborative application:** some applications need a special type of cooperation when exchanging data between their mobile users. Thus, in any time and in any place, the users need to form a network to exchange information in which an ad hoc solution is the most suitable choice.

2.3 Mobile Ad hoc Network (MANET)

The absence of a wired connection between the nodes in this kind of network provides a certain flexibility of movements [18]. We consider that a network is mobile when the movements of nodes allow to establish new wireless connections and disconnections (*i.e.*, appearance and disappearance of links). However, if a network does not contain any connection or disconnection, it can be considered as a static network where the topology of the communication graph remains fixed. Called *Mobile Ad hoc Network*, generally composed of self-organized mobile nodes characterized by its unstable behavior (mobility), which can cause sometimes packet losses. Each mobile node can act as a router relaying data packets from other nodes, which can be carried out using multi-hop communications.

The mobile nodes move randomly and are able to leave or to join the network freely, which results in unpredictable topology changes. The nodes consist of antennas which allow the transmission and reception of signals from other nodes (*c.f.*, Figure 2.3). The transmission range of each node is defined by the radius in which the antenna can operate. The zone covered by the transmission range can be determined

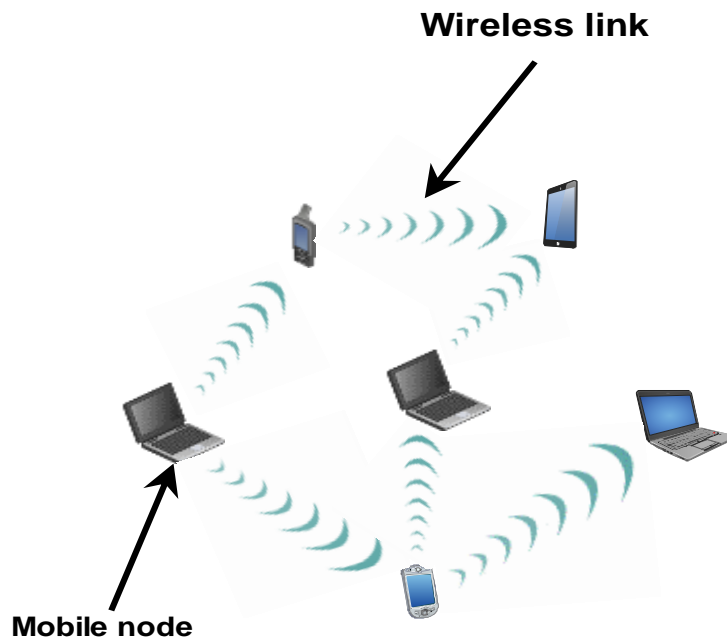

Figure 2.3: Mobile Ad hoc Network.

by the level of transmission power. Neighboring nodes are identified if they are able to hear the transmission of a node forwarding data to another node. The higher level of the transmission power, the large number of neighboring nodes, and the higher level of interference.

2.3.1 MANET Architecture

Two different kinds of architectures are distinguished in a MANET [19, 20]. Firstly, the peer-to-peer architecture where each mobile node has the same role in a peer-to-peer structure. Each node has a total flexibility to move randomly in the network and is able to establish a wireless link with every node belongs to the network. The messages and information are exchanged directly between the nodes.

Secondly, the hierarchical architecture divides the network into different subnets in the form of clusters composed of one cluster head with multiple cluster nodes. Except the cluster heads, all mobile nodes in each cluster share the same radio frequency to communicate with each other, they can move randomly, and are self-organized. Regarding the cluster heads, they use a different radio frequency to communicate with each other. The existing link between the cluster heads provides a virtual backbone, in which the traffic flow is much higher than other wireless links. Thus, all mobile nodes which are located far from the backbone are not able to participate in the

routing process.

2.3.2 MANET characteristics

Thanks to the self-organization of MANETs, the cost of their deployments can be reduced considerably. However, MANETs are not only characterized by their self-organization, several other unique characteristics are distinguished as follows:

- **Dynamic topology:** the constant movement of the mobile nodes in the network can, therefore, make the topology highly dynamic. This has a disadvantageous impact on the routing protocols, which have to ensure a periodical maintenance of the routing path. Among the negative effects which may occur, the increase of the control overhead needed to collect topology information of the network [21, 22].
- **Limited bandwidth:** the wireless physical medium offers a limited bandwidth that must be shared between the mobile nodes within the transmission range of each other [23, 24]. The available bandwidth depends on both the number of mobile nodes present in the neighborhood and the data traffic to be transported, regardless of the physical disturbances that may occur.
- **Restricted energy:** the mobile equipment of nodes are strongly constrained by the limited life of their batteries. Despite the significant improvements in batteries and increasingly energy-saving technologies, mobile nodes are particularly solicited, especially when relaying the network traffic on behalf of other nodes [25, 26].
- **Self-organized:** since MANETs do not have any centralized infrastructure, the mobile nodes have to be self-organized to operate and participate in the proper functioning of the network.
- **Heterogeneity of nodes:** the nodes constituting a MANET can correspond to a multitude of wireless equipment such as laptops, intelligent sensors, mobile phones, *etc.* Each equipment is different from another in terms of physical and software properties, but they must inter-operate to establish a common network [27].
- **Security:** the nature of the physical medium makes MANETs more vulnerable. Wireless transmission can be easily captured by a node located in the neighborhood. A denial of service (DoS) attack can be easily performed by a malicious node by appropriating the bandwidth or by overloading a neighboring node with a large amount of traffic to be routed [28, 29].

2.3.3 MANET applications

Mobile ad hoc networks are easy to be adapted for many situations, in which fixed infrastructures are not suitable or cannot be installed due to the complicated environments. The interest of mobile ad hoc networks increases rapidly in recent year, because the ad hoc mode supports mobility and freedom in the networks. To be more clear, data can be exchanged without cable, access point, or portable memory space. This section briefly describes some popular applications of mobile ad hoc networks [30–32].

- **Military field:** in hostile environments, it may be difficult or too cumbersome to use an infrastructure network. Wireless mobile networks are perfectly adapted to this type of environments where movements are slow and not very sustained. Indeed, a typical mobile ad hoc network was first designed for use in military situations. The soldiers have to communicate with each other on the battlefield in order to make an efficient strategy in front of the enemy. Consequently, installing an infrastructure or equipping each soldier with cable is out of the question due to their flexible movements. A mobile ad hoc network is obviously harder to intercept, more robust, and more suitable for this case.
- **Sensor networks:** As indicated by its name, Wireless Sensor Networks (WSNs) are in the middle of three different architectures: networking, wireless communications, and sensing. The WSNs are wireless networks consisting of a large number of sensor nodes having a low mobility and limited battery life. In addition, among the equipment of a sensor node, a wireless transceiver which has two main functionalities: (i) A transceiver is used to sense activities, and (ii) measures given activities. Also, WSNs can be used in ad hoc fashion to relay the gathered information to data sinks. Consequently, the hop-count may be high. WSNs can provide several useful applications such as information on the temperature in different places of a cold room, the level of sunlight of a room, the health of animals in a zoo, *etc.*
- **Rescue mission and emergency:** in natural disasters, the pre-existing infrastructures may not be operational. Furthermore, it complicates the communication required by the rescue services. A substitution of infrastructure has to be established as soon as possible to support rescue teams. The compactness and speed of deployment of mobile ad hoc networks support the various rescue teams to quickly establish links and exchange information.
- **Personal area network (PAN) and bluetooth:** a PAN is a localized network whose nodes are generally associated with a specified person. Limited-range MANET such as Bluetooth can make simpler the exchange among several portable devices like laptops cell phones. The Bluetooth is a wireless local network, which supports this scenario. It has only small range area transmission (*i.e.*, generally smaller than 10m or 100m), operates in the 2.4 GHz spectrum and does not need infrastructure or cable to connect their nodes.

- **Embedded systems:** a good example for the use of mobile ad hoc networks in embedded applications is the V2V (Vehicle-to-Vehicle) project. Indeed, a consortium of car manufacturers has focused on the exchange of information between vehicles in order to improve the safety of road users. The aim of this project is to make vehicles communicate with each other in a transparent way using an ad hoc network. In the case of danger (*e.g.*, accident, emergency stop, abrupt slowdown, *etc.*), the first vehicle detecting this danger prevents other vehicles using messages. Each vehicle receives this message inform other vehicles that the traffic conditions have been changed. Then, the driver is warned by a light or sound warning of the danger and the behavior to be adopted.
- **Games:** mobile ad hoc networks are well suited for the exchange of information between personal applications. Thus, for users wanting to play using a network, it is easy and low cost to deploy a mobile ad hoc network between each other.

2.3.4 Technical issues in MANET

The characteristics of mobile ad hoc networks involve specific constraints on their functioning, and therefore, negative effects on their performance. The main technical issues that can be encountered in MANETs environment can be grouped into several categories according to the source of the problem [33, 34]. The subsequent list of issues indicates the inadequacies and restrictions that are the most distinguished in a MANET environment:

- **High error rate:** totally different from wired networks, MANETs use radio waves to allow nodes communicate with each other. However, these waves cannot escape the constraints associated with their medium of transmission (air). Several constraints are distinguished such as the electromagnetic, solar, or obstacle disturbances, which affect the transmitted signals, and are, therefore, a source of particularly high bit error rates. Also, the obstacles cause shadowing, reflection, scattering, fading, refraction, and diffraction of the wave. These propagations can result in the contraction of the transmitted packets, and therefore, receive them erroneously.
- **Lower data rate:** the modesty of wireless networking is often highlighted. Compared to some wired networks, the data rates may appear to be low. Consequently, in the context of multimedia transfers requiring a sustained exchange of data, these data rates can be problematic. In addition, the characteristics of wave supported in wireless communications, prevent transmitting a high rate of data than wired communication. A higher frequency can transmit more data, however, it is more vulnerable to interference and perform well in short ranges.
- **Dynamic topology and scalability:** since the mobile nodes can be in constant movement, the network topology also evolves. The neighborhood of a

node can vary continuously: at any time mobile nodes can join or leave the network. The modification of the topology depends directly on the speed of the node movement and the network radius of action. With a rapid and sustained movement of all nodes, the topology continues to evolve. A good algorithm for MANETs has to be able to evaluate and compare the network scalability in the face of nodes mobility. It is very important to know the number of control messages required to transmit a data packet over the network.

- **Mobility-induced route changes:** wireless communication between mobile nodes in MANETs are insecure. Consequently, consecutively conservative procedures for MANETs over a great damage frequency can suffer from performance deprivation. Though, with a large frequency of inaccuracy, it is problematic to supply a data packet to its target destination.
- **Security:** since the signals are broadcasted, they can be heard by any mobile node in the same coverage area. The confidentiality of certain information requires the use of adequate security mechanisms. The data of users from one node to another node must be transferred safely and completely. The least privilege principle can also enhance the security of MANET systems as proposed for organizations. Moreover, there are hybrid models which are also available, offering benefits of two access control models with implementations.
- **Routing:** Routing in MANETs is and always remains an important challenge to overcome. The degradation of performance caused by unicasting, multicasting, and geocasting, requested by the network nodes need a deep research and efficient solutions. Unlike single hop wireless networks, MANETs suffer from many issues such as the frequent change of the topology due to the high mobility of the nodes, energy restrictions, lack in the security side, and several other constraints. These challenges make the routing the most important task to develop.

2.4 Vehicular Ad hoc Network (VANET)

Nowadays, vehicles are considered otherwise than a way of transport. Thanks to recent technological advances, vehicles are equipped with a multitude of information and communication devices, allowing them to interact with the road environment. By exploiting this interaction, the establishment of a dedicated network becomes more than essential to make the experience on the roads more pleasant and safe. In this context, Vehicular Ad hoc Networks (VANETs) can be considered as the keystone of any communication between vehicles and with other road entities to share useful information. In this section, we describe the VANETs architecture and their basic applications, followed by the discussion of the main distinguished technical issues in VANETs. In addition, a specific part of the IEEE 802.11p standard is described and the criteria of connectivity in VANETs and its different constraints are detailed.

2.4.1 VANET Architecture

The various applications and services proposed by VANETs require several kinds of communications. The use of wireless communication in VANETs provides three possible types of communication to share information between the entities of the road [35, 36]. These three possibilities of communications in the VANETs architecture can be summarized as follows: (i) Vehicle-to-Vehicle (V2V) communication, (ii) Vehicle-to-Infrastructure (V2I) communication, and (ii) hybrid communication (*c.f.*, Figure 2.4).

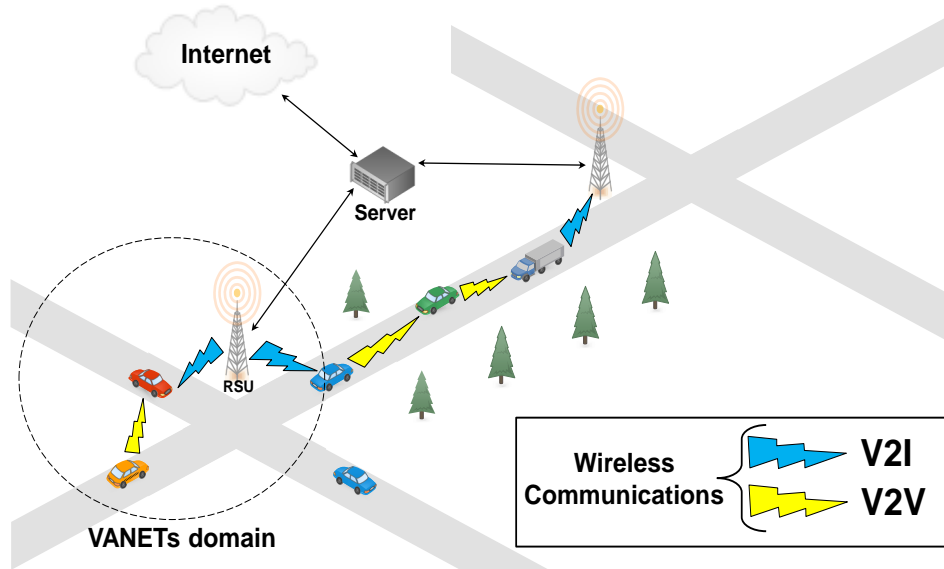

Figure 2.4: Main architecture of VANETs.

- **Vehicle-to-Vehicle (V2V) communications:** there is a real interest in V2V architecture from both industry and the scientific community. This kind of architecture is made up of moving vehicles which create wireless communication links between each other in ad hoc fashion without relying on a fixed infrastructure. Typically, the data exchange between vehicles can be generally classified into three types: (i) Unicast (*e.g.*, sending private data), (ii) Multicast (*e.g.*, exchanging traffic information on a specified area), and (iii) broadcast (*e.g.*, accident warnings). Without any fixed infrastructure, multihop forwarding must be enabled between two vehicles, which are not within the communication range of each other increasing the coverage of all vehicles. It is clear that V2V communications are more efficient in the road safety applications compared with traditional infrastructure networks, which show their limitations, and especially in terms of delay. The advantage of this architecture is the addition of a distinct high bandwidth network to the existing infrastructure network.
- **Vehicle-to-Infrastructure (V2I) communications:** V2I communication (commonly called V2X), this kind of architecture allows moving vehicles to

communicate with road infrastructures, which are fixed along the roads called Road Side Units (RSUs). The communication architecture is centralized, the RSUs are static elements that can act as central points and manage the prioritization of messages to and from the vehicle. This communication is mainly used for applications requires data gathering and information such as Internet Access, traffic information, road condition, data exchange Home-to-vehicle, *etc.* When a vehicle wants to communicate with an infrastructure, the communication is unicast, however, in the opposite direction, the communication can be both broadcast (*i.e.*, disseminating general data) and unicast (*i.e.*, responding to vehicles). Due to its fixed nature, there is no energy restriction since the RSUs are supported with a fixed power supply and a backbone network connection.

- **Hybrid communications:** the combination of these two kinds of communication allows obtaining a very interesting hybrid communication. Indeed, due to the limited coverage of fixed infrastructures, vehicles can be used as relays to extend this coverage (*i.e.*, Plain V2V supplemented with V2I features). The intermediate vehicles are used as relays in order to minimize the number of fixed infrastructures along the roads. RSUs can be seen as access points trying to communicate with all vehicles, while vehicles try to optimize their use of the bandwidth by minimizing the data transmissions with other vehicles. When vehicles enter the communication range of an RSU, they do not only exchange data with the RSU, but they can also exchange data with services supported by the internet, via the access link provided by the RSU (*i.e.*, if such feature is provided).

2.4.2 VANET communication technology

Since 2003, the IEEE organization has been working to define a new standard dedicated to communications in the DSRC band known as IEEE 802.11p/WAVE (Wireless Access in Vehicular Environments) [1, 2]. The DSRC communication model conforms to the OSI architecture but with emphasis on 3 layers sufficient for communication purposes (*c.f.*, Figure 2.5). The layer one is called Physical layer based on the microwave link at 5.8 GHz. The layer two is called Data Link layer, which is dedicated for data management and communications between vehicles and road infrastructure. Finally, the layer three is called Application layer, which is composed of a set of commands that deal with the intended applications (*i.e.*, embedded applications on the device.). The rest of the WAVE protocol stack between the data link layer and the application layer represents the WAVE architecture that the IEEE 1609 group has standardized under four categories as follows:

1. *IEEE 1609.1 - WAVE Resource Manager:* allows remote applications a good management of OBU resources such as: memory and user interface ensuring interoperability.

2. *IEEE 1609.2 – WAVE Security Services for Applications and Management Messages*: describes the packet format and security functions in a WAVE system for security messages, data messages, and management messages.
3. *IEEE 1609.3 - WAVE Networking Services*: defines network and transport services including addressing, routing, and forwarding, which are based on the WAVE Short Messages Protocol (WSMP) that enables efficient exchange of WAVE Short Messages (WSM).
4. *IEEE 1609.4 - WAVE Multi-Channel Operation*: defines priority access mechanisms and allows coordination and management of the seven DSRC channels during routing and data transmission.

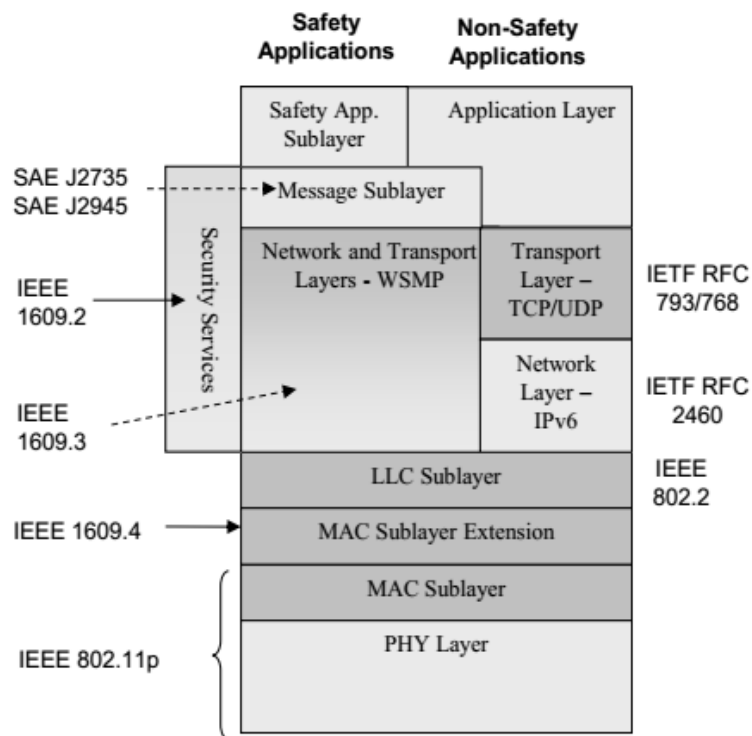

Figure 2.5: Wave architecture [1, 2].

The IEEE 802.11p standard uses the multi-channel concept to provide communications for security applications and other Intelligent Transportation Systems (ITS) services. This protocol responds to a lack of homogeneity between automotive manufacturers and provides sufficient support for the organization of management functions and operating mode for vehicular communications. WAVE provides a set of services and interfaces that collectively provide secure V2V or V2I communications. IEEE 802.11p is the protocol on which WAVE is based at the MAC layer and the physical layer.

- **IEEE 802.11p physical layer:** at the 5.9GHz physical layer (*c.f.*, Figure 2.6), this frequency band is defined in Europe and the United States by ETSI

(European Telecommunications Standards Institute) and FCC (Federal Communication Commission), respectively. It is generally segmented into seven 10 MHz channels each and all channels are functionally divided into one control channel and six service channels. The control channel is dedicated for the transmission of network management messages and messages of very high priority, such as certain critical messages related to road safety. The other six channels are dedicated to the transmission of data from the various services announced on the control channel. IEEE 802.11p is used with the same manner as in IEEE 802.11a, but with 10MHz channels. However some modifications can be made to adapt it to the vehicular environments. It is able to offer a channel capacity between 6 and 27Mbps (for a range that can reach 1000 meters and support speeds up to 200 Km/h) with OFDM (Orthogonal Frequency Division Multiplexing) coding and modulation.

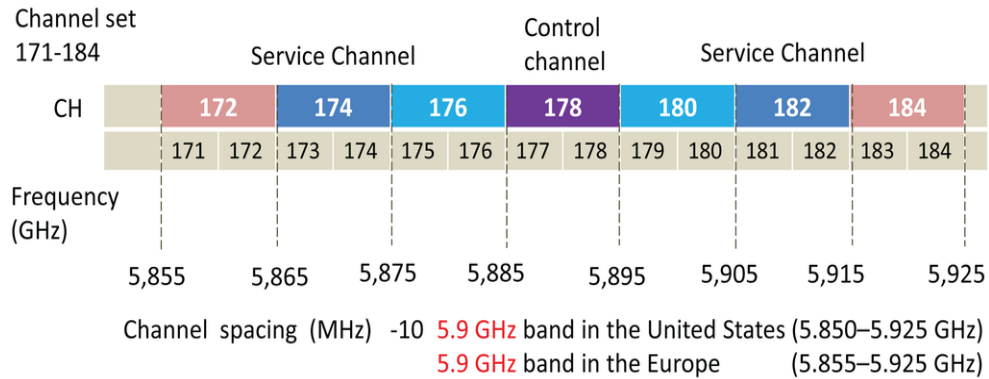

Figure 2.6: ITS/DSRC channel plan [1, 2].

- IEEE 802.11p MAC layer:** at the MAC layer, 802.11p is based on CSMA/CA (Carrier Sense Multiple Access with Collision Avoidance) as in 802.11a protocol. The extensions of 802.11p MAC concern the priority management of the messages to better manage the applications sensitive to the delay. The IEEE 802.11p uses the EDCA (Enhanced Distributed Channel Access) technique at the MAC layer based on that of the IEEE 802.11e with some modifications. When a node wants to make a transmission, it senses the medium first. If the medium is free for an AIFS (Arbitration Inter-frame Space), the node delays the transmission by selecting a random backoff time. In order to guarantee that highly relevant safety messages can be delivered in a timely manner. The 802.11p MAC protocol is based on the priority of the messages using different Access Classes (ACs). AC0 is the lowest priority and AC3 is the highest (See Table 2.1). A data traffic category is assigned to each AC as follows: Background traffic (BK or AC0), Best Effort traffic (BE or AC1), Video traffic (VI or AC2), and Voice traffic (VO or AC3). Different AIFSN (Arbitration Inter-Frame Space Number) and CW (Contention Window) values are selected for different ACs, which are random values selected between CWmin and CWmax.

Table 2.1: Parameter settings for different application categories in IEEE 802.11p [1, 2].

AC	CWmin	CWmax	AIFSN	T μs
BK	15	1023	9	264 μs
BE	15	1023	6	152 μs
VI	7	15	3	72 μs
VO	3	7	2	56 μs

2.4.3 VANET characteristics

Vehicular networks have specific characteristics that distinguish them from other types of mobile networks (*e.g.*, MANETs, WSNs). VANETs support ad hoc communications between mobile nodes in highly dynamic network scenarios. Nevertheless, research studies dedicated for MANETs cannot be applied directly to VANETs since these latter present unique specificities [37, 38]. Here are some characteristics that distinguish a network such as VANETs:

- **Network environment and mobility model:** the topology of VANETs is highly dynamic, but the mobility of vehicles is limited by predefined paths (*e.g.*, roads), directions of travel, and the number of lanes on roads. Vehicle trajectories are fairly predictable at the equipment level. The environment where VANETs are deployed can be urban, rural or highway. Constraints imposed by such environments such as traffic lights and speed limits greatly affect the mobility and density of vehicles. Thus, VANET protocols have to handle these variations of the density and all its own features, which are considered as challenging tasks to overcome [39].
- **Scalability:** vehicular networks can grow rapidly, especially in urban areas where intersections and multi-lane roads are frequent. Consequently, the proposed protocols must deal with the scalability. As a result, a large number of possible collisions on the communication medium and interference between the nodes during their transmissions [40].
- **Processing, energy, and communication capacity:** contrary to the context of MANETs or WSNs, where the energy constraint represents one of the problems treated in the literature. The elements of VANET have no limit in terms of energy and high processing capacity. Therefore, the problem of the energy restriction no longer arises in VANETs. In addition, each vehicle in the network is equipped with a device called an on-board unit (OBU). It performs a set of applications and supports several wireless technologies used for the communications such as WiMax [41], WIFI [42], GSM [43], Bluetooth [44], *etc.*
- **Density and network topology:** Unlike most mobile wireless networks, vehicular networks are characterized by the high mobility of their nodes. This

is essentially due to the high speed of vehicles and their sudden change of directions, especially on highways and urban areas. Therefore, a node can join and leave the network in a very short period of time, which makes the topology very unstable. Moreover, the density of the network can vary according to the environment (*i.e.*, urban, rural, highways) and according to the time of day (*e.g.*, a low density at a late hour of the night). Consequently, the protocols designed for vehicular networks have to face the challenges of density variation and high mobility [45, 46].

- **Anonymity and security in the network:** among the major challenging tasks in VANETs privacy and data security, which are considered as crucial components to be designed. Indeed, the shared medium and wireless communication used in VANETs are very vulnerable. The attacks can be performed without making physical access to network infrastructure. Therefore, it is a mandatory condition to develop VANET protocols as reliable as possible and secure them against attacks [47, 48].

Beyond the characteristics introduced above, vehicular networks are also distinguished by a variety of attractive and specific applications. In the following, the VANET applications can be categorized into three main different categories as follows: road safety applications, traffic efficiency and management applications, and infotainment applications.

2.4.4 VANET Applications

VANETs consist of three main classes of applications [49, 50], which can be classified according to their functionalities (*c.f.*, Figure 2.7). Indeed, the applications related to the road safety, traffic efficiency, and infotainment constitute the major part of the VANET applications [51]. Several services are provided by these applications bringing interesting prospects for telecommunications operators seeking new services. Each class of applications requires a different level of performance and quality of service. Generally, three types of metrics are considered, the end-to-end delay to respect the lifetime of an information, the delivery ratio to ensure a minimal ratio of data delivery, and the throughput to guarantee a certain access channel rate.

Road safety applications

Assist drivers in order to avoid vehicle collisions and decrease car crash death ratios [52–55]. Therefore, this kind of applications is very sensitive to the delay and are mostly related to the traffic information, which should be up-to-date periodically. These applications can be summarized according to concrete examples in order to identify their specific features.

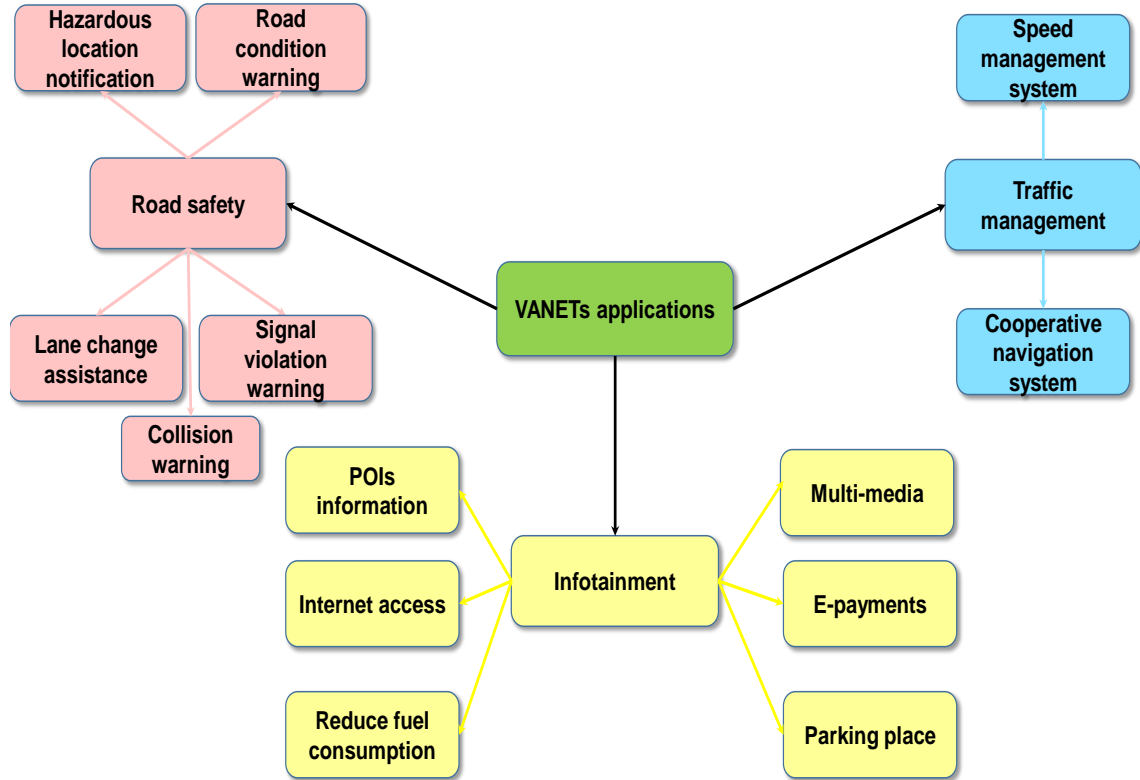

Figure 2.7: Main applications in VANETs.

- **Collision warning:** when a vehicle or an infrastructure detects a crash on the road, they broadcast information about the crash (*i.e.*, the positions of accidents) based on V2V/V2I wireless communications between the vehicles near the accident approaching each other in the same or opposite direction, in order to prevent them from danger. The advantage of this scheme is to allow vehicles changing their direction or the line in which the crash is produced in order to avoid further traffic accidents and maybe a serious traffic congestion.
- **Signal violation warning/Traffic light:** the traffic lights fixed in most cases at the intersections can play a role of RSUs. The signal violation is detected when a vehicle violates a road signal, which increases significantly the risk of an accident. In this case, based on V2I communications, the RSUs (Traffic lights) broadcast temporary messages to all vehicles in the area in order to inform them that a vehicle has violated the signal, and consequently, reduce the risk of an eventual accident [56].
- **Lane change assistance:** this technique provides the required assistance to a vehicle wanting to change the lane. This is done by informing vehicles located on neighboring lanes in order to facilitate this change using V2V communications.
- **Road condition warning:** this service is responsible for preventing vehicles

on the dangerous conditions of the road, which are caused by ice storms or other slippery substances on the roadway. In each vehicle, on-board sensors collect information about the condition of the roadway in order to both alert the driver and to send messages to other vehicles [57].

- **Pre-crash sensing:** the objective of this type of service is to alert drivers to accidents that may occur due to current conditions. The service is based on multi-hop V2V communication, in order to inform drivers localized in the area. The exchanged messages may contain information about the geographical position, direction, speed, and acceleration of vehicles so that to exchange them with vehicles and thus avoiding the risk of accidents.
- **Hazardous location notification:** this application plays an important role in the information of vehicles about any hazardous location either permanent or temporary. It aims to reduce the risk of accident and have the purpose to allow vehicles have a global knowledge about the roadway. The technique of V2V and V2I communications are used by this application, in which periodical or authoritative messages are triggered by traffic management entity.

Traffic efficiency management applications

Obviously, the exchanged messages with this type of application are intended to improve the road traffic through the selection of suitable roads and paths, while taking into consideration potential traffic jams or obstacles in order to circumvent them. This allows the distribution of the road traffic, reduce the travel time of drivers, and save on fuel consumption. The information provided by this kind of application has to be always available, in order to allow drivers make the right decisions at the right time during the trip. Two main services can be provided by these applications, the speed management and cooperative navigation systems.

- **Speed management system:** this system aims to assist drivers for smooth driving with managing the speed of vehicles and avoiding unnecessary stopping [58, 59]. Furthermore, this system can alert drivers about the speed excess using a green light best speed advisory or regulatory/contextual speed limit notification. This system is beneficial to improve the road safety, enhance the traffic flow, and to reduce the vehicles' pollution. The RSUs can be used as the main entity to regulate the speed of vehicles by broadcasting periodically the speed limits using V2I cooperative awareness messages.
- **Cooperative navigation system:** in this system, The V2V and V2I communications are used to manage the navigation of vehicles in order to increase the traffic efficiency [60–62]. Road situations and real-time traffic information are collected by moving vehicles, such as under construction road segments, traffic jam, road accidents, *etc.* Then above information need to be transmitted in

real-time to related vehicles through VANETs to be processed by the navigation system to choose the optimal moving path. The fixed RSUs can play an important role in this system, by broadcasting periodically some local traffic information and provide circulation advices to reduce traffic jam.

Infotainment applications

The main objective of this category of applications is to provide road users with information, advertisements, and entertainments, which makes commuting a pleasant experience [63]. These applications aim to improve the comfort of drivers and passengers. For instance, they provide information of general utility, such as weather forecast or other information on the localization of the closest restaurant or prices at a gas station. Also, they allow passengers to access to Internet-based services. Numerous popular applications are known in this category, which have different requirements such as connectivity, availability, and reliability, in order to provide the information that the drivers need in a timely manner.

As depicted in Figure 2.7, several applications are illustrated [63–66]. The road users are no longer need to stop. Indeed, they can take advantage and utility of these applications when they are interested. Moreover, these applications can provide Internet access, instant messages, games, and other services, while being more tolerant to additional delays. Also, they aim to provide comfort services, which are meeting the preferences of road users.

2.4.5 Technical issues in VANET

The VANETs have the advantage of not being conditioned by the problems related to the memory space, computing capacity, and energy. However, VANETs suffer from a large amount of data to be sent and wider geographical areas to be covered. In addition, the dispersal and high mobility of vehicles, lack of infrastructures, and network density variation create several technical issues for data delivery. Below we list a few examples of these problems:

- **Signal fading:** sometimes direct communications between some vehicles are impossible due to the high-rise buildings, even though the distance is smaller than the transmission range. Indeed, the present obstacles have a direct impact on the connectivity, which can affect the performance of the data delivery, and therefore, impact the accuracy of the connectivity. This is mainly due to the fading, which is increased significantly in the wireless channel and reducing the transmission efficiency [67].
- **Density and connectivity:** the density of vehicles in VANETs is not constant, it can be very low, as in the case of rural areas with low traffic or very high

in a congested urban network. This has a direct impact on the delivery ratio and the delay of data delivery. Indeed, in low-density scenarios, disconnections frequently occur, which can cause high transmission delays and low delivery ratios of messages. Similarly, for high-density scenarios, competition for access to the communication channel is high, causing message collisions, and therefore, many packet losses and low delivery ratios of packets [68, 69].

- **Bandwidth limitations:** VANETs do not have any coordinator for the allocation of the bandwidth to vehicles. Then, it becomes the responsibility of each vehicle to manage these resources equitably [70, 71]. This can increase waiting times before access to the channel and thus the latency of messages. Indeed, VANETs use radio communications. Consequently, it is important to design specific MAC solutions for VANETs. In addition, it is required to conceive protocols, which provide quality of service and manage priorities by solving problems of radio interference, multi-path problems of waves, electromagnetic irregularities, distributed resource allocation in a dynamic topology, *etc.*
- **Scalability issue:** the number of vehicles is increased significantly. The amount of information collected and exchanged within the VANETs does not the same. In fact, the growing number of moving vehicles has a large effect on the network connectivity as well as the collisions of packets and wireless interferences. This implies that any proposed solution for VANETs considers, from its conception, the problems of scalability. For this reason, we make sure that all the solutions we propose to VANET issues support scalability [72].
- **Security and privacy:** are among the major challenges which have a great impact on the future deployment of vehicular networks and their applications. For instance, selfish vehicles may try to clear up the way ahead or mess up the way behind with false information, which can result in serious crashes and even loss of human lives. In the case of privacy, a lot of information about vehicles is shared in VANETs, which is easy to be collected such as speed and velocity. Consequently, malicious drivers intercept this kind of information and falsify it and use it against the driver. In this context, the development of security mechanisms that establish trust relations between communicating entities of the road and guarantee access control of services as well as the security of data transfers is of paramount importance [73].
- **Routing protocols:** in order to communicate with each other, the vehicles have to define a routing protocol. Indeed, when the vehicles are not within a direct radio transmission range, unicast routing is required to establish communication between two vehicles or between a vehicle and a fixed infrastructure. Each vehicle can, therefore, act as a sender, receiver, or router [74]. Finding the connected end-to-end connected path satisfying delay restrictions and minimal overhead is confronted with many constraints and difficulties. Such difficulties are due to the high mobility of vehicles, the frequent path failures, and the various obstructions, which may affect the reliability of the data transmission and routing.

2.5 UAV Ad hoc Network (UAANET)

The recent progress of wireless technology has been witnessed in our daily life, particularly because of the vast availability of low-cost Wi-Fi radio interfaces and other devices like GPS, sensors, micro-embedded computers, *etc.* All these innovative devices have paved the path for the development of small intelligent flying vehicles, *e.g.*, Unmanned Aerial Vehicles (UAVs), leading to the creation of a new kind of network called UAV Ad hoc Network (UAANET) [75]. Since the introduction of UAANET, different kinds of civilian and military applications have emerged, such as the coordination of rescue teams on the ground [76–78], border supervising [79, 80], and autonomous tracking [81–84]. In addition, there are also many civilian applications such as agricultural and yards monitoring, discovering oil fields, and film-making [84–88]. These types of applications need a serious support from several research areas, which require attracting the attention and interest of scientists.

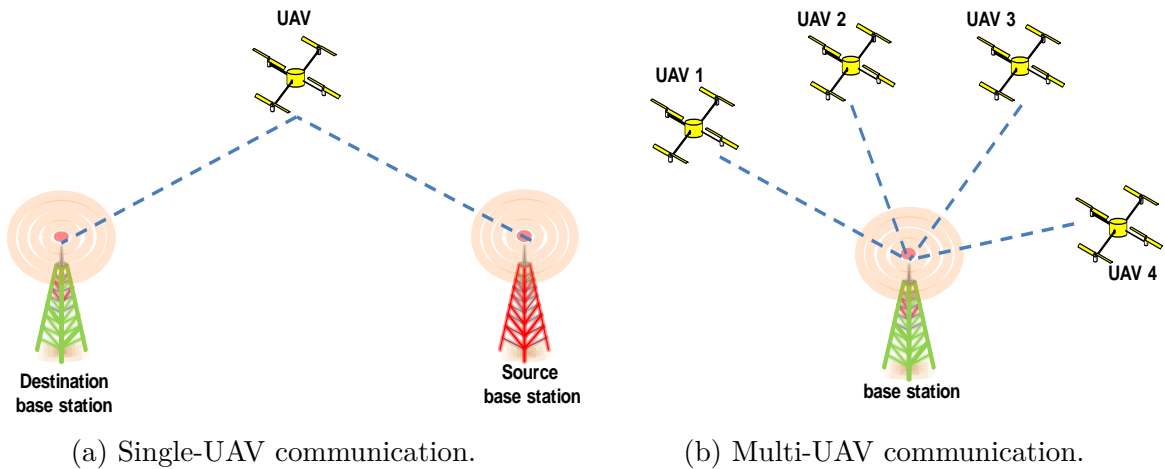

Figure 2.8: UAANET Transmission modes.

Two kinds of applications of aerial nodes exist (*see* Figure 2.8). First, single-UAV applications in which the UAV is at the center of a set of base stations localized on the ground. The UAV can be used by the base stations as a router (relay) to communicate with other base stations, which are not within their communication range. However, several issues can be found such as the short transmission range of UAV and the problem of interference. To overcome these challenges, the second application is the use of a team of UAVs, which provides many possibilities to solve these problems and supplies a variety of applications called multi-UAVs applications [89]. The advantages of multi-UAVs over a single-UAV can be summarized as follows:

- The fault tolerance in the multi-UAVs is increased when a node fails.
- In the cooperative missions, the tasks can be parallelized decreasing considerably the duration of the missions.
- The capabilities of calculations and storage can be distributed among UAVs.

2.5.1 UAANET Architecture

UAANETs have a similar standard as MANETs in which the nodes are flying, creating different characteristics. Figure 2.9 shows two different kinds of communication which can be established between the nodes forming a classical UAANET:

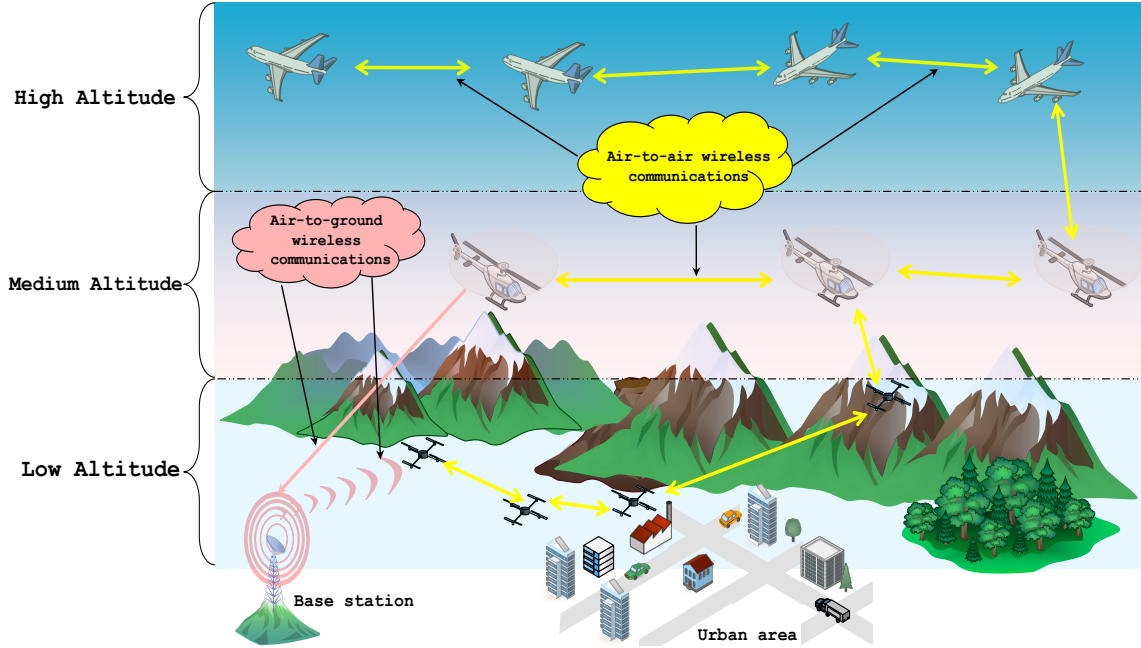

Figure 2.9: Wireless communications between UAANET nodes.

1. **Air-to-air wireless communications:** UAVs can communicate with each other using a pure ad hoc architecture in order to avoid the restrictions on the transmission ranges imposed by the communication between UAVs and the ground base stations [90]. In addition, this kind of wireless communication can be used to support different applications and multi-hop communications when the node wants to establish a transmission of the data packet to another node outside of range.
2. **Air-to-ground wireless communications:** in UAANET, not all UAVs can communicate with existing infrastructures such as ground stations and satellites [89]. However, only selected UAVs can establish a communication with infrastructures in order to both improve and increase the connectivity and to provide additional services.

UAANET can be seen as a special case of MANET in which we distinguish certain differences like the very high degree of mobility of UAANET nodes and the long distances between them. These may require wider communication ranges and different techniques to overcome these constraints. The wireless communication between UAANET nodes is considered as a challenging task, which needs rules of communication in a form of routing protocols supporting the effectiveness of such transmissions.

2.5.2 Unmanned Aerial Vehicle (UAV)

Unmanned Aerial Vehicle (UAV) and drone are two terms used frequently to talk about the same thing. The UAV or drone is an aircraft without a human pilot on-board; either an operator on the ground pilots it, or it is auto-controlled by an on-board computer system. The unique characteristics of UAVs are their predefined movements in the sky, their high mobility compared with default MANET nodes (*i.e.*, their speeds can exceed 400 km/h [91]), and the control algorithms of their movements. This means that the topologies of UAANETs are not constant and change recurrently causing frequent link failures between the UAVs. The different categories of UAVs can be classified based on different criteria, such as usage (*e.g.*, mapping, monitoring, *etc.*), weight, altitude, endurance, or even the range of data link. However, the best criteria for the UAVs classification are the aerial platforms [92]. There are four major types of UAVs identified by their aerial platforms, such as Multi-rotor UAVs, Single-rotor UAVs, Fixed wing UAVs, and Fixed wing Hybrid UAVs (*c.f.*, Figure 2.10).

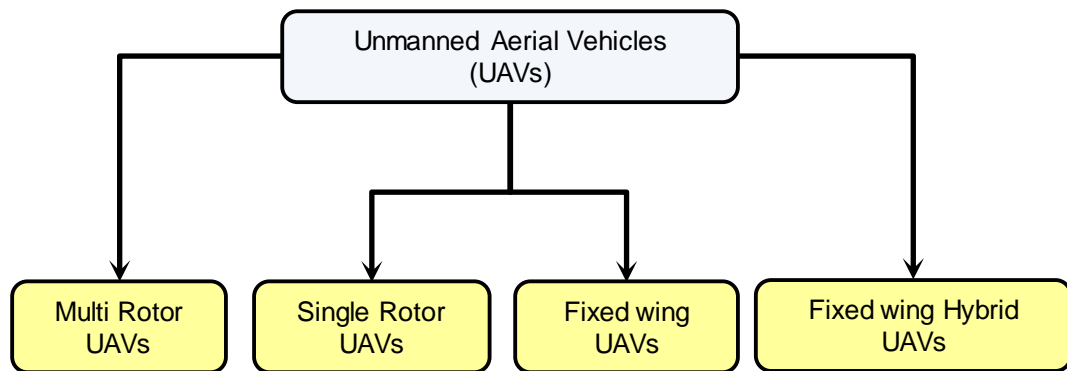

Figure 2.10: Classification of UAVs.

- *Multi-rotor UAVs*: this kind of UAVs have multiple rotors present in their structure. Currently available multi-rotor drones include quad-copters, hex-copters, and octo-copters. The most commonly used multi-rotor drones are quad-rotor drones (*c.f.*, Figure 2.11(a)). Because of their flexibility and durability, quad-rotor drones are considered in a lot of applications such as aerial photography, aerial video surveillance, *etc.* Overall, multi-rotor UAVs are the cheapest option available in the market and the easiest to manufacture. In addition, multi-rotor UAVs are fundamentally very efficient in terms of energy consumption because the small rotors do not need a large amount of power to keep the UAVs in the air. However, the expected flight time are limited to approximately 20 to 30 minutes depending on the models.
- *Single-rotor UAVs*: Unlike multi-rotor UAVs, a single rotor UAV has only two rotors. The first is a big sized rotor placed on the roof of the UAV, while the second is a small sized one placed on its tail to control its heading (*c.f.*, Figure



(a) Quad-rotor UAV



(b) Single-rotor UAV



(c) Fixed-wing UAV



(d) Fixed-wing hybrid UAV

Figure 2.11: UAV types.

2.11(b)). In contrast with multi-rotor UAVs, the single-rotor UAVs have higher flying times and can even be powered by gas engines. In aerodynamics, the lower the count of rotors the lesser will be the spin of the object. Consequently, they are more stable during the flight compared with multi-rotor UAVs. However, this kind of UAVs comes with much higher operational risks, complexity, and their costs are also on the higher side. They also require a special training to fly them on air correctly.

- *Fixed-wing UAVs*: this kind of UAVs use a "wing" like normal manned airplanes (*c.f.*, Figure 2.11(c)). This allows to never use the engines to stay afloat on air (*i.e.*, cannot stand still on the air) fighting gravity. However, the engines can solely provide the forward thrust needed, making them much more efficient than the multi-rotors. Also, they can fly at high speeds and stay in the air for much longer periods of time. Consequently, fixed wing UAVs are considered as the ideal choice for mapping or surveillance of large areas. As a limitation, fixed wing UAVs are characterized by their higher costs and skills training required in flying.
- *Fixed-wing Hybrid UAVs*: this kind of UAVs are a hybrid version combining the benefits of multi-rotor models (hover) with that of fixed wing models (higher flying time). Accelerometers and a vertical lift are both used to keep the drone stabilized in the air and lift the drone up into the air from the ground, respectively (*c.f.*, Figure 2.11(d)). Package delivery is among the main applications of

these UAVs. However, this kind of UAVs is not widely available in the market and their prices are not affordable for a normal budget user.

2.5.3 UAANET characteristics

As a special class of MANET, UAANET is differentiated by its unique properties that characterize the nodes and the surrounding environment. Several main characteristics can be employed to characterize UAANET: UAVs, density, network connectivity, energy autonomy, propagation model, topology, scalability, localization, and mobility models. All these characteristics are described and discussed as follows:

- **Density:** the density of nodes in UAANET is generally low because of the great distances separating the nodes which can reach kilometers [93], resulting in the use of wider transmission ranges. Furthermore, the high speed of UAVs and their wide transmission ranges are sufficient to cover the entirety of the network (*i.e.*, the limited mission zone). Overall, the majority of the UAANET applications can be executed using a restricted number of UAVs [90].
- **Network connectivity:** due to the low density and the very high mobility of nodes, UAANET can be considered to be sparsely connected. This results in the fluctuation of the link quality which may cause loss of connectivity and performance degradation. To address this problem, a solution is proposed, which consists to create an ad hoc network between the nodes in order to extend the communication coverage [94]. Even if nodes cannot establish a connection with existing infrastructures on the ground, they can still communicate through other nodes.
- **Energy autonomy:** according to [95], the power and the movements of UAANET nodes are powered and supplied using the energy resources of the nodes. Indeed, there is no energy restriction since each node is equipped with rechargeable batteries, which are continuously recharged as UAVs moving. Also, batteries may be powered by the nodes' resources such as solar energy, gasoline, electrical energy, *etc.* In addition, the amount of energy needed to move a UAV is much greater than the energy required for computing data. Consequently, we can say that UAANET nodes do not have energy power restrictions compared with MANET nodes, where developers have to make more attention to the energy consumption by the communication protocols to extend the lifetime of the network [96].
- **Propagation model:** unlike other ad hoc networks such as Mobile and Vehicular Ad hoc Networks (MANETs and VANETs), which operate, in the most cases, on the ground and their radio propagation models are vulnerable to existing obstacles. In addition, the line-of-sight is prevented between the nodes [96]. UAANETs are less exposed to obstacles which allows nodes to have a line-of-sight between each other. The UAVs usually move in the sky. Consequently, in

the simulation, the free-space path loss model is the most used in the physical layer. However, we cannot ignore big obstacles (*e.g.*, buildings and mountains) or weather conditions which can affect the links between nodes.

- **Topology:** the topology of UAANETs changes permanently and more frequently than VANETs or MANETs. Several phenomena can affect the topology of UAANETs such as the link failures between the nodes, the speeds, and direction changes of the nodes. Consequently, the critical information (*i.e.*, control packets) has to be managed in the network [96]. In addition, efficient data exchange strategies have to be adapted to the frequent change of the topology.
- **Scalability:** in many UAANET applications, the performance is related to the number of UAVs. For instance, search and rescue missions need more UAVs to be quickly completed [97]. In addition, the mobile nodes in UAANETs move randomly and are able to leave or to join the network freely. As a result, we can say that UAANET protocols should work independently of the number of UAVs while ensuring a minimal performance degradation.
- **Localization:** due to the high mobility of nodes, UAANETs need to be equipped with an accurate localization system such as a Global Positioning System (GPS) [96]. Moreover, because of the extra delay caused by the GPS, UAANET must also be equipped with Inertial Measurement Unit (IMU) in order to solve the problem of the delay and to provide accurate geographical positions as quickly as possible [98, 99].
- **Quality of Service (QoS):** certain UAANET applications need efficient real-time services such as the transmission of aerial photography and video for a real-time monitoring [95]. Several metrics have to be taken into consideration such as end-to-end delay, available bandwidth, packet losses, and jitter. As a result, designed applications for UAANET have to take a minimum of QoS requirements for their correct functionality.
- **Mobility models:** the movements of nodes in UAANET are generally defined beforehand. However, due to external factors (*e.g.*, weather, mission, *etc.*), the movements can be updated which can affect directly the mobility model of nodes. In addition, mobility models proposed for MANETs are not suitable for UAANETs, in which their use results in the establishment of inadequate path plans [96].

We can say that a UAANET protocol has a satisfying performance level outcomes if it covers all UAANET specific characteristics mentioned above. As a result, there is a clear need to develop robust protocols for UAANETs, which have to be tested and validated in real scenarios. However, the protocols proposed for VANETs and MANETs cannot be deployed directly to support the unique requirements of UAANETs. Following (*see* Table 2.2) is the main differences between MANETs, VANETs, and UAANETs.

Table 2.2: Difference between UAANETs, VANETs, MANETs.

Characteristics	MANETs	VANETs	UAANETs
Density	<i>High</i>	<i>High</i>	<i>Low</i>
Network connectivity	<i>High</i>	<i>Medium</i>	<i>Low</i>
Energy autonomy	<i>Low</i>	<i>High</i>	<i>High (Depends on UAV kind)</i>
Topology variation	<i>Occasionally</i>	<i>Frequently</i>	<i>Very frequently</i>
Scalability	<i>Medium</i>	<i>High</i>	<i>Low</i>
QoS	<i>Low</i>	<i>High (Depends on the application)</i>	<i>High (Depends on the application)</i>
Mobility models	<i>Random</i>	<i>Restricted through roads pattern</i>	<i>Predefined by mobility models</i>
Node speed	<i>Medium</i>	<i>High</i>	<i>Very high</i>

2.5.4 UAANET applications

Many factors make the UAANET nodes easy to be deployed in different environments. Their ease of organization in an ad hoc network, allows us to not wait too long to create a UAANET in which its nodes can communicate and exchange data between each other. Flying nodes can also communicate with different infrastructures localized on the ground such as base stations or ground bases. It has, however, been observed that different obstructions can affect the communication between flying nodes and base stations such as mountains, walls, and buildings, which may block the radio signals of both infrastructures and flying nodes [96]. Three kinds of applications can be distinguished in UAANETs as follows: Multi-UAV cooperation, UAV-to-Ground tasks, and UAV-to-VANET collaborations.

Multi-UAV cooperation

Certain particular tasks require a cooperation between several UAVs to be carried out according to a certain time limit. The high number of UAVs in each task is, the more accurate the obtained results will be, and the less the reduced time of the task. This decentralized mechanism offers more robustness since it is not related to any fixed infrastructure on the ground. Many kinds of applications are based on Multi-UAV cooperations such as detection, accurate geographic localization, tracking and monitoring in disaster, and emergency situations [100].

As multi-UAV applications [101–109], all of them try to provide an appropriate and optimal solution using a given number of UAVs cooperating toward a particular task.

UAV-to-Ground tasks

Important information has to be communicated between UAVs and the human operator located on the ground so that to take the right decisions in different scenarios such

as search and rescue missions, military monitoring, and other civilian applications.

We can cite as UAV-to-ground applications [110–118], in which the wireless communication can be established between both UAVs and mobile or fixed nodes on the ground.

UAV-to-VANET collaborations

Recently, a new kind of wireless communication has emerged between UAVs and vehicles on the ground cooperating in an ad hoc mode with each other in order to accomplish certain tasks. This creates a new possibility of potential research issues in UAV-to-VANET communications, and consequently, can be beneficial to design more applications in the near future.

Until now, the UAV-to-VANET cooperation can be used in different applications such as road traffic explorations, routing improvements, data packet delivery, traffic monitoring, route guidance, *etc.* The main applications proposed for this kind of cooperation are [8, 10, 119, 120].

Based on the analysis done above, TABLE 2.3 produces a comparative study between the characteristics of the different types of UAANET applications.

Table 2.3: Comparison of potential scenarios for UAANET .

Parameters	Multi-UAV cooperation	UAV-to-Ground tasks	UAV-to-VANET collaborations
UAVs density	High	Medium	Low
Ground environment	Not aware	Aware	Aware
Infrastructure	No	Yes	Maybe
Obstacles effect	Low	High	Medium
Task duration	Limited	Not limited	Not limited
Human operator	No	Yes	Maybe

2.5.5 Technical issues in UAANET

UAANET architecture is under a continuous development, since the research over this kind of a highly dynamic network is not complete on several levels, and the routing is not an exception. Communications between UAVs always remain the most challenging task, because the existing routing protocols proposed for MANETs as well as VANETs cannot satisfy the unique requirements of UAANETs. Finding a single routing scheme able to adapt to all the unique characteristics of UAANET, and at the same time, provides perfect outcomes is very hard and quasi-impossible.

Although there is a wide range of proposed routing solutions, there still exist several issues that have not been resolved and need a deep research. For instance,

in terms of UAANET nature and communication environments, most of the routing protocols were not proposed by considering these crucial details. Such routing protocols have not functioned perfectly under a network severely partitioned. Furthermore, UAANETs cannot cope with the security requirements, where the nodes are exposed to any kind of attack. To overcome such unique characteristics, different details should be considered further in designing UAANET routing protocols. In this section, we have identified several open challenges that need more study in future research.

- **Network partitions:** the main causes of this problem are the low density of UAANET nodes and their high degree of mobility. Future solutions have to take into account these issues by adopting appropriate techniques or using, for instance, another kind of nodes located on the ground. The adequate placement of UAVs can also play a key role in order to remedy this problem of partition [121–124]. Therefore, developing new techniques to cover the entirety of the network, while avoiding the network partitions is still an open issue.
- **Security:** crucial information is exchanged between UAANET nodes, and compromising them has catastrophic outcomes. Further studies need to be carried out to design security methods to make the proposed routing protocols more secure. The majority of the proposed routing protocols focuses essentially on the performance improvements, and do not provide any defense against attacks or malicious attackers. Indeed, if the UAVs are hijacked, they can be used as a weapon or as something more dangerous. Only a few secure routing protocols are proposed in the literature [125, 126], hence the necessity to propose new routing solutions including security components.
- **Simulation:** the implementation of UAANET routing protocols needs to be more credible and realistic and uses reasonable assumptions. A unique simulation tool or package should be designed in order to unify the parameters so that to apply verification methods for all the proposed solutions to determine their proof of correctness and complexity. More and more simulation tools and testbeds are used to evaluate existing solutions about UAVs and UAANET in general [127–129]. The majority of them do not provide reasonable and realistic outcomes, due to their negligence of many known characteristics of this kind of network. In addition, more realistic mobility models need to be designed in order to get more realistic results both in the data exchange and evaluation criteria. Therefore, the mobility of UAVs, as well as the simulation tools, still remain open issues for future research in order to evaluate accurately the routing protocols performances.
- **UAANET applications:** several UAANET applications are conceived based on the cooperation of nodes such as improving the routing protocols, search and rescue missions, and recently deployed to assist VANET on the ground to improve traffic management in VANETs and can also provide a road guidance for emergency vehicles [130, 131]. The mapping applications could also be an

open research issue since there are only a few proposed solutions. All these challenges need to be more studied in order to propose suitable solutions taking into consideration the unique characteristics of UAANETs as well as provide more useful applications.

- **Quality of Service (QoS):** QoS is considered as an additional issue to be addressed and integrated into the routing solutions in UAANETs. Because of some applications such as streaming video, P2P connections, GPS localization, *etc.*, require a certain level of QoS in order to support their right functionality. In addition, QoS can provide a certain satisfaction to a set of requirements imposed by some performance constraints of services such as bandwidth, packet losses, delay restriction, jitter, *etc.* In certain routing protocols supporting QoS, these limitations could be considered as metrics to measure the degree of performance. The QoS could be a promising research challenge regarding the different constraints proper for UAANETs.
- **UAVs cooperation:** certain applications require the cooperation of several UAVs to be done efficiently, and in most cases, in a timely manner (*e.g.*, search and rescue missions). However, this requirement is not always an easy task, due to the unique characteristics of UAANETs such as the high mobility and the network partitions. In addition, this kind of cooperation needs a minimal of constant connectivity between the nodes in order to exchange crucial information to accomplish a given mission with an accurate way. Consequently, efficient mobility models, strategies of communication, and the flexibility to the environment would have to be investigated by the proposed protocols in order to ensure efficient cooperation of the nodes [106, 132–141].
- **UAANET standardization:** there is a deeper need for standardization of UAANET communications, which allows a certain degree of flexibility. Indeed, UAANETs have to operate with different frequency bands according to the application areas. Therefore, the standardization of these communication bands becomes a mandatory condition in order to reduce the problem of frequency congestion and to unify the way of communications between the nodes [89].
- **UAV equipments and adequate placements:** UAVs are characterized by their small size and can carry a predefined device, such as integrated cameras, single radars, image sensors, *etc.* In the case when there is a need to use the integrated sensor with a radar, UAVs should cooperate with different other UAVs. For instance, one UAV can be equipped with a radar, while another UAV is loaded with a sensor. This is beneficial to decentralize the tasks among the UAVs. There is an open issue in this topic to optimize the UAV equipment and their adequate placements to increase the efficiency of the mission while reducing the energy consumption [89].
- **Coordination of manned aircraft with UAVs:** With the increasing number of UAVs, and especially near airports, the coordination of UAVs with manned aircraft becomes crucial and inevitable. In the future, this coordination should

be done automatically in a networked environment without human interactions. In addition, it will be an effective way of avoiding accidents between these two flying nodes. Therefore, this topic can be considered as an open issue needing a deep research [89].

- **Path Planning:** In UAANETs, each UAV can maintain its current path or change it according to the mission or the situation. This should be done by re-calculating automatically the paths and coordinates with other UAVs. Consequently, cooperation and coordination between UAVs are not only desirable, but also a crucial feature to increase efficiency. Thus, new solutions/methods in dynamic path planning need to be conceived [89].
- **Routing:** among the main open issues for UAANETs and cooperating UAVs, is the routing (*i.e.*, the rules of communication between UAVs). Indeed, the data exchange between UAVs faces serious issues, which are quite different from those distinguished in MANETs or VANETs. The UAVs should be able to have a real-time global knowledge of the dynamic topology of a network like UAANET. This is why the proposed routing solutions for UAANETs or even the techniques of the data delivery taken from MANETs and VANETs have to deal with these challenging constraints. Consequently, there is a crucial need to develop efficient routing techniques which provide at least a flexible behavior with the topology of UAANETs. Furthermore, a minimum level of performance has to be defined to guarantee the efficiency of the proposed routing schemes.

2.6 Conclusion

The main idea behind this *chapter* is to introduce the background of wireless ad hoc networks. Hence, this kind of network paradigm provides different forms of networks. MANET, VANET, and UAANET are the kinds of networks described in this *chapter* with their specific requirements and characteristics. Furthermore, the main applications of each network are presented, which require effective strategies for the management of communications channel resources, quality of service, and communications security. However, several technical issues are distinguished during the deployment of these applications. Indeed, each kind of network has its own characteristics, which generate unique constraints.

The success of all these applications relies on a reliable and robust data packet delivery and need to be verified through many studies related to these communication protocols. Consequently, routing protocols have to be conceived to support the requirements. The unique characteristics of the studied networks such as the frequent change of the topology and the high mobility of nodes can cause several link failures on the routing paths already established. In addition, the majority of the proposed routing protocols dedicated to these kinds of networks try to address the problem of frequent disconnections and the wireless links instability. Because, this may affect the performance of routing, and therefore, impact the accuracy of the connectivity between the nodes.

There are many research problems in the field of VANETs and UAANETs. In this thesis, we will focus on those related to the routing of data, connectivity among the nodes, and the cooperation between the nodes of VANETs and UAANETs. The next *chapter* will be dedicated to the presentation and description of the routing concept as well as the different routing solutions proposed in the field of VANETs and UAANETs.

Chapter 3

Routing in VANETs and UAANETs

Contents

3.1	Introduction	39
3.2	Routing in VANETs	40
3.3	Routing techniques in VANETs	41
3.4	Routing protocols for VANETs	43
3.5	Topology-based VANET routing protocols	43
3.6	Position-based VANET routing protocols	44
3.6.1	Reactive-based routing protocols	44
3.6.2	Greedy-based routing protocols	46
3.6.3	Delay-tolerant-network-based routing protocols	46
3.7	Comparative study of VANET routing protocols	47
3.8	Routing in UAANETs	49
3.9	Routing techniques in UAANETs	51
3.10	Routing protocols for UAANETs	53
3.11	Topology-based UAANET routing protocols	53
3.12	Position-based UAANET routing protocols	54
3.12.1	Reactive-based routing protocols	54
3.12.2	Greedy-based routing protocols	56
3.12.3	Delay-tolerant-network-based routing protocols	58
3.12.4	Heterogeneous routing protocols	60
3.13	Comparative study of UAANET routing protocols	61
3.14	UAANET-to-VANET communications	66
3.15	Conclusion	67

3.1 Introduction

The communication between the nodes of an ad hoc network is a promising solution that allows nodes belonging to the same network to exchange useful information. For instance, this kind of exchange is considered as a crucial support for the comfort and safety of driving in VANETs and to accomplish specified missions in UAANETs. In order to carry out this wireless communication, rules have to be established for the information delivery between the nodes. These rules are simply routing protocols that take into account the constraints of each kind of networks. Furthermore, the aim of these rules is to ensure a strategy which guarantees, at any time, the connection between any pair of nodes belonging to the network. Indeed, when the nodes are not within a direct radio transmission with each other, a routing is required. Therefore, each node can take the role of a sender, a receiver, or a router. However, a number of problems can arise, such as the unstable paths between each pair of nodes due to the high mobility and discontinuous connectivities that characterize vehicular and UAV ad hoc networks, which can make the routing a difficult task to be accomplished.

The main objectives of a routing protocol conceived for highly dynamic networks such as VANETs or UAANETs are as follows:

- Establishment of shortest and robust paths between the communicating nodes.
- Consideration of the frequent topology changes as well as the specific characteristics which characterize each kind of networks.
- Treatment of the path failures using efficient recovery strategies.
- Minimization of the end-to-end delay during the data delivery.
- Reduction of the packet losses.

The aim of this *chapter* is to present a state of the art in VANETs and UAANETs routing. In addition, to be able to ensure an efficient data delivery in such networks, it is necessary to know all possible routing techniques and environments of deployment. Moreover, we define each category of the proposed routing protocols in each kind of networks based on proposed taxonomies. Then, we describe the functioning details of selected routing protocols from each category. To differentiate between the proposed routing protocols, comparative studies based on several parameters are presented. These comparisons allow to distinguish all weak points of the studied protocols. At the end, we introduce a novel heterogeneous communication scheme between existing VANETs on the ground and UAANETs in the sky.

3.2 Routing in VANETs

The problems related to routing in vehicular networks are far from clear. The difficulty lies mainly in the instability of routing paths caused by the high mobility of nodes and the frequent fragmentation of the network. Indeed, the fact that the network has a partial or an intermittent connectivity indicates that the routing management must be different from the topological approaches used in traditional mobile ad hoc networks (MANETs).

The main routing strategies for VANETs can be deployed in different environments, which are diversified by several displacement areas. These areas are differentiated by their locations and specificities (*i.e.*, speed, density of vehicles, road patterns, *etc.*). For instance, the urban environments are characterized by a complex mobility model, high vehicle density, and reduced speed, which are mainly caused by existing intersections and stop points (*e.g.*, traffic lights, stop, give way, *etc.*). However, as for the highway and rural environments, the roads are characterized by long distances, which makes these environments to be less disruptive for radio waves during inter-vehicle communications. Hence, the need to install access points (*i.e.*, RSUs) along roads that act as gateways to extend the connectivity in the network is greater than ever before.

Nowadays, inter-vehicular routing is still a major challenge, and especially, in urban environments characterized by the high density of vehicles (especially at intersections) and the presence of obstacles (*e.g.*, buildings, *etc.*). The proposal of a new routing solution must meet the requirements and peculiarities of this kind of environment whose constraints considerably affect the mobility model of nodes and the routing performances. Consequently, the routing path between vehicles may not be ensured all time due to the high mobility of vehicles. So finding a shortest end-to-end path is very difficult, especially in urban areas because of the vehicle's mobility pattern, which is constrained by obstacles and pre-existing roads. However, most existing protocols do not fully consider the impact of the existing obstacles that can affect directly the performance of the routing, and therefore, impact the communication between vehicles. Furthermore, most of the topology-based routing protocols designed for MANETs are not considered suitable for VANETs, since they pass over the unique characteristics of such networks [142]. Nevertheless, compared with topology-based routing, position-based routing demonstrated high efficiency and resilience to handle the high mobility of nodes and the frequent disconnections in a network such as VANET.

The next sections describe three important points: (i) the routing constraints in urban areas and the most adopted routing techniques, (ii) the main position-based routing protocols proposed in this kind of environment. We note that the topology-based routing protocols are partially investigated since they are not suitable for highly dynamic networks such as VANETs. Finally (iii) a general comparative study based on several criteria between the discussed protocols is presented.

3.3 Routing techniques in VANETs

Communications between vehicles have to take into account the specific characteristics of urban areas [143]. Indeed, the urban environments are characterized by existing obstacles, which considerably affect the quality of the radio transmission. These obstacles can also cause the reflection phenomenon of the radio signal, which is propagated by several paths and is received by an antenna. Furthermore, frequent disconnections are distinguished in this kind of areas, which are mainly due to the high mobility and complex movements of vehicles caused by the road patterns and the drivers' behaviors. These constraints have to be taken into account by the protocols.

Several techniques have been adopted by the position-based routing protocols in order to adapt to the constraints and the inherent characteristics of vehicular networks and also to succeed in an efficient routing, which guarantees a reliable data delivery. Among the most used routing techniques in VANETs, we distinguish:

- **Store-carry and forward:** it consists to keep¹ the packet to be sent in the current vehicle that it does not have immediate neighbors. This until it encounters a node closer to the destination or reaches the destination itself [144]. Figure 3.1 (A) illustrates an example of this local recovery strategy functioning.
- **Greedy forwarding:** the main criterion for selecting a relay is to choose the nearest neighbor vehicle to the target destination. Indeed, the source or the current vehicle selects the geographically closest vehicle to the target destination, which is within its transmission range (*see* Figure 3.1 (B)).
- **Unicast-based routing:** consists to transmit the data packet to a specific destination, hop-by-hop through the network. This technique is the most commonly used in Vehicle-to-Vehicle (V2V) communication (*see* Figure 3.1 (C)).
- **Cluster-based routing:** as shown in Figure 3.1 (D), several groups are formed with a leader in each group that handles communication between groups. However, given the high mobility of vehicles and their unpredictability of movements, the groups will be partitioned continuously, making the application of this technique less effective in this kind of network.
- **Broadcast-based routing:** it consists to broadcast the data packet by each node receiving it for the first time except the destination (*see* Figure 3.1 (E)). The advantage of this technique is that the data packet will arrive at its destination, but it can cause an excessive consumption of the bandwidth.
- **Geocast-based routing:** it consists to deliver data packets to other nodes within a certain specific geographical area called Zone of Relevance (ZOR) (*see* Figure 3.1 (F)). However, to avoid the flooding of the network, another zone is used to limit the transfer of geocast data packets until they reach the ZOR.

¹Save the packet to be sent in a buffer for a certain duration

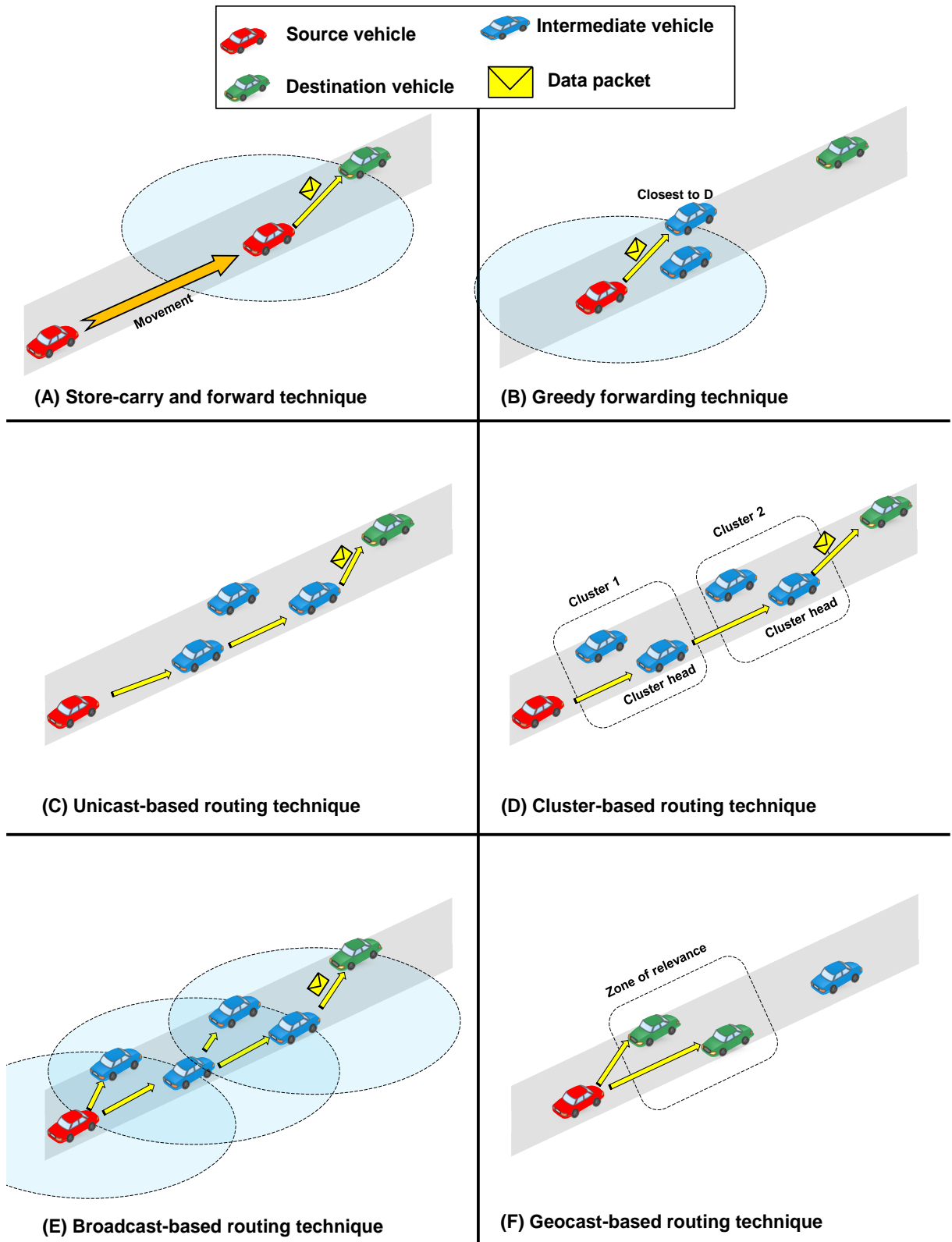

Figure 3.1: Main VANET routing techniques.

3.4 Routing protocols for VANETs

An important number of routing protocols have been proposed. All of them try to find an optimal solution for forwarding data using different methods and assuming different hypotheses with a common objective to ensure a high throughput, an acceptable level of packet loss, and keeping the network overhead under controllable levels.

As illustrated in Figure 3.2, VANET routing protocols can be classified according to the adopted technique in the data delivery process. Based on our proposed taxonomy, there are two relevant categories: (i) topology-based routing and (ii) position-based routing. The first category does not demonstrate high efficiency and resilience to handle the high mobility of VANET nodes. However, the second category is able to adapt to highly dynamic networks such as VANETs. In addition, it has provided interesting results in terms of end-to-end delay and delivery ratio. In the following sections, we reviewed the main routing protocols for VANET with a focus on the most popular position-based routing protocols proposed in each category.

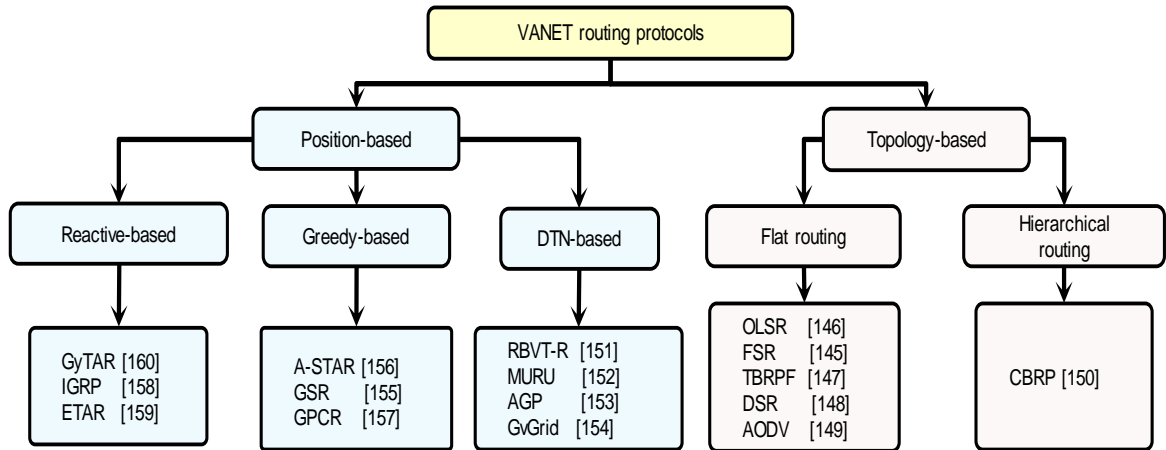

Figure 3.2: Taxonomy of VANET routing protocols.

3.5 Topology-based VANET routing protocols

The topology-based protocols are not suitable for highly scalable networks such as VANETs [142]. Indeed, several topology-based approaches initially proposed for MANETs are deployed for VANETs without taking into account the unique characteristics of such networks. We distinguish several categories of topology-based routing protocols, in which each of them has its own specificities.

The first category is the flat routing, which can be divided into two subsets: on the one hand, the proactive protocols (FSR [145], OLSR [146], TBRPF [147]) and, on the

other hand, reactive protocols (DSR [148], AODV [149]). A proactive protocol keeps all possible routes for each destination in the network in a routing table that it builds and maintains periodically. Therefore, the routing path is available immediately. Conversely, reactive protocols wait for a route to be requested in order to determine it using a discovery process. In this case, an additional delay is required at the beginning of each session to find the path. In general, these routing protocols (*i.e.*, proactive and reactive) are well suited to low or medium transmission range ad hoc networks, but reach their limits for networks with a high number of nodes.

The second category is the hierarchical routing, which consists of dividing the network into clusters for better dissemination of routing information. Indeed, clustering consists of classifying the nodes of the network in a hierarchical way according to certain parameters: address, geographical area, capacities, *etc.* A subset of nodes is elected, in a distributed manner, each playing the role of local coordinator. Among the hierarchical routing protocols CBRP [150], which aims to reduce the routing table size based on the used clustering method. The algorithm of clustering used by CBRP is based on the following steps: (i) forming cluster heads (election), (ii) communication between cluster heads, and (iii) maintenance of cluster heads.

3.6 Position-based VANET routing protocols

This category of protocols is considered as the most suitable for vehicular networks [142]. With the GPS standardization, the source node can use geographic position information to make the decision to select the best routing path to deliver the data packet to its target destination. In a general case, the geographical position of the destination is included in the header of the data packet by the source, which is then sent by taking into consideration the position of the direct neighbors. All information is crucial for the right transition of the data packet.

3.6.1 Reactive-based routing protocols

The reactive process is considered as the most used technique in VANETs. Routing protocols using this technique are adequate to scenarios where vehicles are frequently leaving or joining the network, which corresponds to highly dynamic networks. Several routing protocols are proposed.

Road-Based using Vehicular Traffic (RBVT) [151] is based on two different routing protocols, the proactive protocol (RBVT-P) and the on-demand routing protocol well-known as reactive (RBVT-R). RBVT-R performs route discovery on-demand and reports back to the source based on the greedy forwarding using a route reply (RR) in which it includes in its header the position of the destination and a list of traversed intersections. In the case when the destination received several route discovery (RD),

this means that RBVT-R has to choose the path that has the smallest number of traversed junctions (shortest path to the source) among many discovered paths and then to send the RR through it. Once the source receives an RR, it starts sending data packet via the same path traversed by the RR. As a drawback, RBVT-R selects the shortest path (*i.e.*, the minimum number of transited intersections) back to the source without taking into account the vehicle density on the road segments which may cause, at any time, a disconnection problem.

MURU (Multi-hop Routing protocol for Urban VANET) [152] calculates a metric called Expected Disconnection Degree (EDD) which is a probability that a given path might be disconnected during a given time period. The lower of EDD, the better is the path. The EDD is estimated by combining the vehicle positions, velocities, and trajectories. Consequently, the path containing vehicles moving at similar speeds and directions is considered as more stable, and therefore, more desirable. After calculating the shortest path to the destination, the source initiates the route discovery and at the same time the EDD is calculated permanently at each hop and stored in the route request (RREQ). When the destination receives a certain number of RREQs, it chooses the path with the smallest EDD. The principal drawback of this protocol is that it does not take into consideration the vehicle density, which is an important factor to measure the connectivity and ensure an efficient data delivery.

The authors in [153] use a route discovery process for both finding the destination location and installing a robust data delivery path. At the end, several RREQs reach the destination indicating several routing paths. Then, the destination calculates a weight for each different path (a set of intersections) based on the vehicle density and the delay. The path which obtains the best weight will be selected to send the route reply (RREP) back to the source using a greedy forwarding technique. To deal with the mobility of the destination, an intermediate vehicle can use a trajectory prediction based on additional information (velocity and motion direction of the destination) included in data packets. The major disadvantage of this protocol is that it does not calculate the real distribution of vehicles between two successive intersections on the selected path, which may cause a path failure even if this path contains a large number of vehicles.

Sun *et al.* proposed a routing protocol destined for urban environments called GvGrid [154]. GvGrid adopts a grid-based approach using a discovery phase to construct routing paths. The map is assumed to be initially divided into several grids. The RREQs are delivered along the roads through different grids in order to find routing paths composed of a minimum number of grids. Several useful information and parameters are recorded in the routing table such as the source vehicle, the destined grid, and the grids sequence. If the routing path fails, GvGrid has to find another vehicle in the disconnected grid instead of the previous vehicle. In the case when the network is severely partitioned, vehicles are not able to use the process of grids since there is no vehicle to be selected as a next hop. In addition, GvGrid supposes that the network is highly dense, which is not reasonable since, as widely known, the number of vehicles is a random variable and not constant during the day.

3.6.2 Greedy-based routing protocols

The majority of the proposed routing protocols for VANETs employ greedy forwarding as a data delivery technique. The proposed greedy-based routing protocols aim to reduce the number of hops and minimize the delay of the data delivery.

GSR [155] (Geographic Source Routing) calculates the shortest path to the destination based on the map geographic information using Dijkstra's Algorithm. The data packet has to transit through a sequence of intersections initially selected by the source vehicle. The Greedy Forwarding is used when transferring data packets between two successive intersections. As a drawback, GSR calculates the full routing path without taking into account the traffic density information, which is an important factor that can affect the performance of the packet delivering. In fact, GSR can select paths where there are not enough vehicles, and therefore, more packets will be lost due to the lack of connectivity.

To avoid the drawback of GSR, A-STAR [156] (Anchor-based Street and Traffic Aware Routing) is a routing protocol operating in urban areas which takes into account the traffic density on roads. It is based on the street map to compute the sequence of intersections (anchor) through which a data packet is delivered to its destination. It takes into account the city bus route information to identify anchor paths with a higher connectivity. However, this protocol can suffer from problems of local maximum and connectivity in a certain time period.

GPCR [157] (Greedy Perimeter Coordinator Routing) is a routing protocol destined for city environments. The main idea of the protocol is to take the advantage from the natural planar graph about roads and intersections. The protocol consists of two strategies: (i) restricted greedy forwarding and (ii) repair strategy. GPCR uses a restricted greedy approach for data forwarding and uses recovery approach, where the packets are going to be delivered using the reverse greedy mode and can find an alternative solution to switch back to the greedy mode.

3.6.3 Delay-tolerant-network-based routing protocols

In VANETs, several partitions can occur due to the high mobility. Vehicles may employ the store-carry and forward technique to cache data packets until the network becomes progressively connected.

The authors in [158] proposed Intersection-based Geographical Routing Protocol (IGRP) for routing packets in city environments. IGRP selects road intersections through which a data packet is delivered to the target destination (Internet gateway). The selection is based on many criteria such as the connectivity of the road intersections, the quality of service constraints, the tolerable delay, and the bandwidth usage. The technique of greedy forwarding is used between two selected intersections

to make the data delivery efficient while reducing the sensitivity to an individual mobility of vehicles. The connectivity is also taken into account in different moments of the day, even the nighttime (sparse network). However, IGRP only considers the fixed destination (Road Side Units) and has not proved its effectiveness on mobile destinations.

ETAR [159] (Efficient Traffic Light Aware Routing Protocol for VANETs) selects road intersections based on a score calculated by combining four parameters: (i) the connectivity, (ii) the traffic density, (iii) the remaining distance between a pair of nodes (Source/Destination), and (iv) the indicated traffic light. The data packet is delivered through a sequence of gradually selected intersections depending on the previous parameters by using a completely distributed technique based the periodical exchange of Hello messages between vehicles. As a drawback, ETAR does not take into account the real distribution of vehicles which is an important factor to measure the degree of connectivity on segments. In addition, when the network becomes sparse, it is difficult to find a connected road segment to deliver the data packet, and consequently, the data packet will be carried only by the (source/forwarder) vehicle increasing the delivery delay. Furthermore, in a certain time, the packet cannot be delivered due to the direction which is already taken by the carrier vehicle.

GyTAR [160] (an improved Greedy Traffic aware Routing Protocol), uses a dedicated multihop packet called CDP (Cell Data Packet) generated by each vehicle leaving a road segment and reaches an intersection, in order to calculate the number of vehicles between two successive junctions. A vehicle wants to forward a data packet, calculates a score for each segment that allows reaching the destination based on the distance and the density of vehicles. Then, it sends the packet with the road segment which has obtained the highest score. The main drawback of this protocol is the problems caused by the transmission of CDP like the additional overhead, channel collision, and channel utilization.

3.7 Comparative study of VANET routing protocols

Based on the analysis done above, TABLE 3.1 summarizes the characteristics of the routing protocols proposed for urban vehicular networks. By reviewing these protocols, we can say that the excess of overhead and the fragmentation of the network are the major drawbacks which are suffered by the proposed routing protocols. That is why the newly proposed routing schemes have to deal with all these challenges by adopting an efficient routing technique, which avoids congestion and the frequent link disconnections between vehicles.

Table 3.1: Comparative study between routing protocols.

Criteria	Reactive-based routing				DTN-based routing			Greedy-based routing		
	RBVT R	AGP	MURU	GvGrid	GyTAR	IGRP	ETAR	A STAR	GSR	GPCR
	Ref.[151]	Ref.[153]	Ref.[152]	Ref.[154]	Ref.[160]	Ref.[158]	Ref.[159]	Ref.[156]	Ref.[155]	Ref.[157]
Carry and forward	No	No	No	No	Yes	Yes	Yes	No	No	No
Greedy forwarding	No	Yes	No	Yes	Yes	Yes	Yes	Yes	Yes	Yes
Path discovery	Yes	Yes	Yes	Yes	No	No	No	No	No	No
Single path	No	No	No	No	Yes	Yes	Yes	Yes	Yes	Yes
Multi path	Yes	Yes	Yes	Yes	No	No	No	No	No	No
Recovery strategy ¹	Recalculate path				Carry and Forward			GF	GF	RHR
Location service	✓	×	×	✓	✓	✓	✓	✓	✓	✓
GPS	✓	✓	✓	✓	✓	✓	✓	✓	✓	✓
neighbors Table	✓	✓	✓	✓	✓	✓	✓	✓	✓	✓
Traffic lights impact	×	×	×	✓	×	×	✓	×	✓	✓
Infrastructure	×	×	×	×	×	✓	×	×	×	×
Mobility	SUMO	VanetMobiSim		NETSTREAM	VanetMobiSim	SUMO	VanetMobiSim	—	—	VanetMobiSim
Simulation tool	NS-2	NS-2	—	—	QualNet	MATLAB	NS-2	NS-2	NS-2	QualNet
Evaluation metrics ²	P, E	P, E, H	P, E, O	P, E	P, E, O	P, E, H	P, E	P, E, H	P, E, H	P, H
Drawbacks ³	O, C	O, C, LO	O, C, LO	O, D, C	O, D	O, D	O, D	LO, GF1	LO, GF1	LO, GF1

¹Recovery strategy: GF: Greedy Forwarding, RHR: Right Hand Rule.

²Evaluations metrics: P: Packet Delivery Ratio, E: End-to-End Delay, O: Overhead and H: Number of hops.

³Drawbacks: O: Overhead, D: Delay, C: Congestion, LO: Local Optimum, GF1: Greedy Failure NEL: No Expiration Links.

3.8 Routing in UAANETs

Since UAANETs have specific characteristics and operate in a special environment, they have also their own routing techniques. In fact, UAANETs are considered as a subclass from MANETs (*see* Figure 3.3). Therefore, common techniques are shared for data delivery [96]. However, for the right functionality of the forwarding process, these techniques have to be adapted to both mobility models and operating environments, which are specific to UAANETs. Also, these requirements are quite different from those of MANETs and VANETs. The selection of the relays to forward data packets is crucial since it has to be efficient to avoid the packet losses.

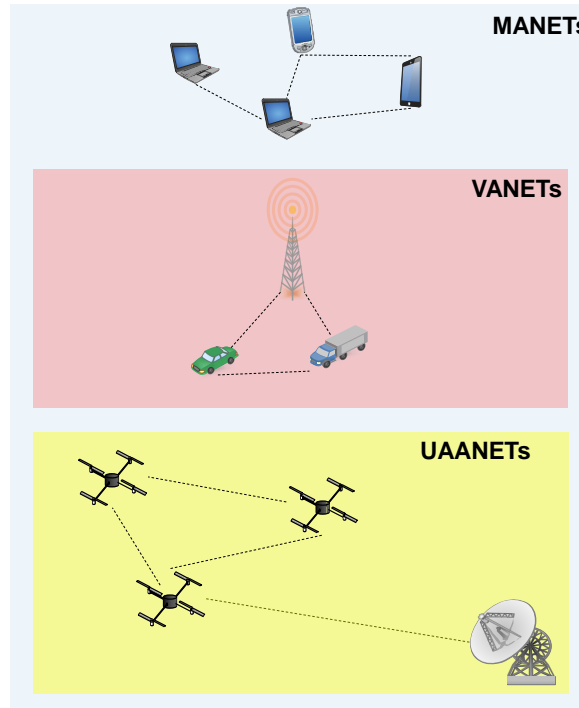

Figure 3.3: UAANETs subclass.

There is a wide range of routing protocols proposed for UAANETs. All these protocols are intended to improve the packet delivery ratio and to provide low delays and packet losses. In addition, all UAANET characteristics, and especially the high mobility of nodes have to be taken into consideration. UAANET routing protocols can be classified into two main categories according to the followed technique and the idea behind each protocol: (i) Topology-based routing protocols, and (ii) Position-based routing protocols. The next sections below investigate the most relevant routing protocols. We note that the topology-based routing protocols are partially investigated since our work is based only on the most important position-based routing protocols, which are the most suitable for this kind of networks.

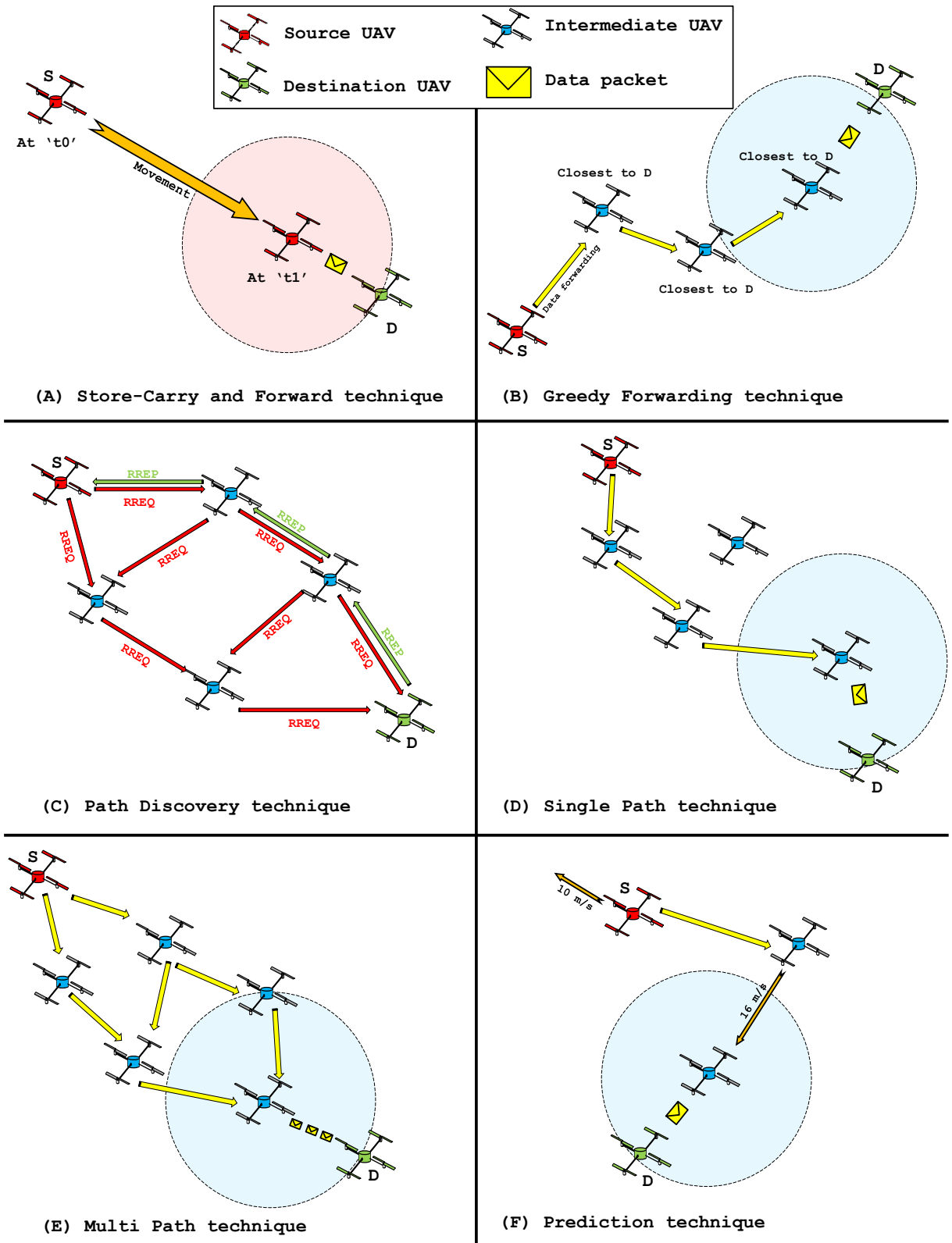

Figure 3.4: Main UAANET routing techniques.

3.9 Routing techniques in UAANETs

Various environments of deployment are distinguished in UAANETs. Each environment is characterized by particular elements such as the kind of area located on the ground in which UAVs exchange information (*i.e.*, urban, rural, highways, *etc.*) and the altitude in which UAVs interoperate. In addition, the highly dynamic nature of UAANETs and the unpredictable movements of nodes can cause several link failures resulting in frequent packet losses. Consequently, several constraints and issues arise in each kind of environment which all have to be considered by adopting the suitable technique of data exchange. However, each adopted kind of technique has its own drawbacks, but it always remains the most suitable in a given kind of situation.

Figure 3.4 summarizes the most popular technique used for data delivery in UAANETs. Following we describe the most adopted routing techniques in UAANETs.

- **Store-Carry and Forward:** at a certain moment, when the network is intermittently connected, the forwarder nodes do not have any solution to find a relay node. Consequently, it is not possible to forward any data packet to a predefined node which does not exist in the transmission range. Only in this case, the current node tends to carry the packet until meeting another node or the target destination itself. This kind of routing is known as the *store-carry-and-forward* paradigm. Its cost is not negligible in terms of delay, which is caused by the physical movement of the node. This kind of technique is often used in UAANETs since they are poorly dense and partially connected (*see* Figure 3.4 (A)).
- **Greedy Forwarding:** this technique is used when a conventional UAANET is densely deployed. The purpose of Greedy forwarding is to minimize the number of hops in which a data packet can make during its transition to the target destination. The principle is to select the geographically closest node to the target destination as a relay node and so on until the packet reaches its destination. Some drawbacks are to be deployed, such as the local optimum problem, in which the process is blocked at a node which is considered as the closest to the destination and cannot find any relay nodes to reach it. In this case, a combination of other techniques should be used to ensure the reliability of this technique. Figure 3.4 (B) illustrates this type of routing technique.
- **Path Discovery:** as shown in Figure 3.4 (C), the discovery process is deployed when the geographical position of the target destination is not known by the source node. The discovery is based on the RREQs' dissemination to find all possible paths to the target destination. When all possible paths are received by the target destination, a suitable path is selected according to specific criteria. Then, this path is used for data packet transition. The discovery process is among the most used methods in existing UAANETs routing protocols due to its simplicity. Furthermore, the advantage of this technique is that the message will

arrive at its destination, but the cost for this is significant and may unnecessarily cause excessive consumption of bandwidth.

- **Single Path:** as indicated by its name, this technique consists of establishing a single routing path between two communicating nodes. This may simplify the handling of the routing tables in each node constituting the path. However, the major disadvantage of this technique is that when a fault occurs in the network and there is no alternative path to forward data packets, it may result in crucial packet losses (see Figure 3.4 (D)).
- **Multi Path:** unlike the single path technique, in the multi path technique, there are several paths between two communicating nodes. It is more complex to maintain the routing tables of the nodes since a node can be a central point of two different paths or more. Nevertheless, when a fault occurs, the multi-path routing can easily detect the fault and find an alternative solution as fast as possible. As a drawback, it is very complex to configure such technique, because the slightest error results in routing loops blocking the network. This technique is illustrated in Figure 3.4 (E).
- **Prediction:** there are several forms of prediction techniques for data delivery used in UAANETs. The most popular one is the prediction based on the geographical location, direction, and speed, to predict the future position of a given node. All these parameters can give an accurate information about the next relay node location which decreases considerably the packet losses, and sometimes reducing the end-to-end delay between two communicating nodes. Figure 3.4 (F) represents a prediction technique based on the future geographical location of a next relay node.

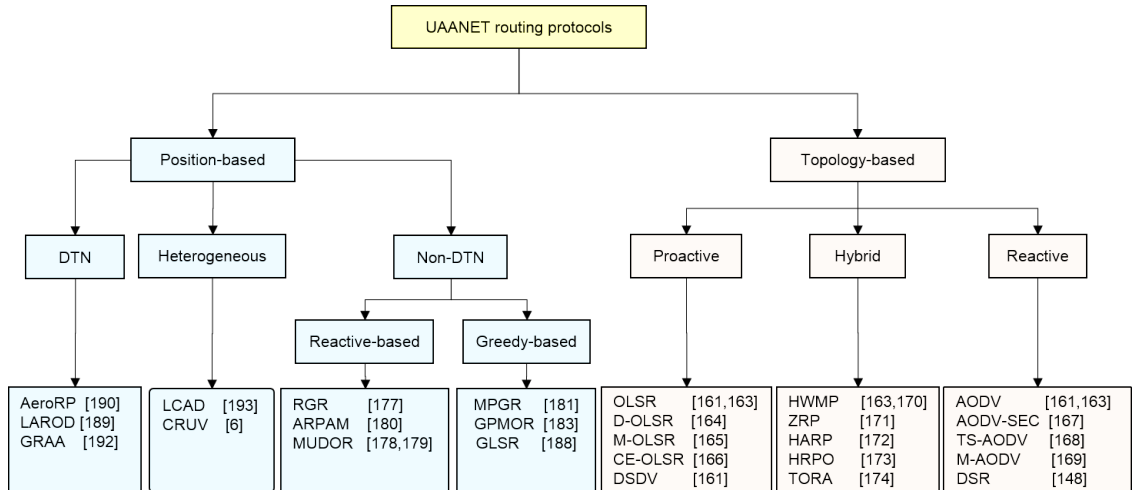

Figure 3.5: Toxonomy of UAANET routing protocols.

3.10 Routing protocols for UAANETs

There is a wide range of routing protocols proposed for UAANETs. All these protocols are intended to improve the packet delivery ratio and to provide low delays and packet losses. In addition, all UAANET characteristics, and especially the high mobility of nodes have to be taken into consideration.

As shown in Figure 3.5, UAANET routing protocols can be classified into two main categories according to the followed technique and the idea behind each protocol: (i) Topology-based routing protocols, and (ii) Position-based routing protocols. The next sections below investigate the most relevant routing protocols. We note that the topology-based routing protocols are partially investigated since this section is dedicated to study the most important position-based routing protocols, which are the most suitable for this kind of networks.

3.11 Topology-based UAANET routing protocols

This category of routing protocols exploits IP addresses to define the nodes and uses the existing link information in the network to forward packets through the appropriate paths. The protocols are classified as Proactive routing, Reactive routing, and Hybrid routing.

In this kind of routing protocols, tables are computed and used by each node in order to save all routing paths between every pair of nodes in the network. The main benefit of a proactive routing strategy is that all latest routing paths are available in each node. Therefore, the sender selects immediately the best route to the receiver minimizing considerably the delay of the data delivery. However, these tables are updated and periodically shared with neighbors, and especially when the network topology changes, which results in the abuse of the bandwidth consumption. In addition, proactive routing protocols are inappropriate for UAANETs because of the low reaction to the frequent connection failures and the considerable need for memory and processing due to the scalable nature of UAANETs. The most popular proactive routing protocols proposed or adapted to UAANET in the literature are OLSR [161–163], D-OLSR [164], M-OLSR [165], CE-OLSR [166], and DSDV [161].

To overcome the overhead problem of proactive protocols, Reactive routing protocols (on-demand) use a flooding method when there is no route between two nodes when it is necessary. The sender that wants to send a data packet to a receiver, it initiates a route discovery by flooding a route request (RREQ) packet through the whole network. The receiver replies with a route reply (RREP) packet. Consequently, this kind of repetitive path discovery can satisfy the requirements of highly mobile ad hoc networks such as UAANET, because there are no periodic updating of links [96]. However, reactive routing can suffer from the high latency due to the route

discovery which may take a long time. Furthermore, it cannot be suitable for security applications in UAANET. Several reactive routing protocols have been proposed during the last decade: AODV [161, 163], AODV-SEC [167], Time-slotted AODV [168], M-AODV [169], and DSR [148].

To make the routing more efficient and scalable, hybrid routing protocols are introduced. This kind of protocols is the combination of reactive and proactive strategies in order to overcome the limitations of each one (*i.e.*, the high latency of a reactive routing and the huge overhead of control messages of a proactive routing). A Hybrid routing strategy divides the network into zones. Inside the zones, a proactive routing is applied in order to reduce the overhead of the periodic exchange of messages to update the routing tables. The communication between zones is ensured by the reactive routing [89]. As hybrid routing protocols which are adapted to UAANETs, we can cite HWMP [163, 170], ZRP [171], SHARP [172], HRPO [173] and TORA [174].

3.12 Position-based UAANET routing protocols

This class of routing protocols is based on the knowledge of the geographical positions where each node is able to define using the GPS. We note that for calculating the position of the destination, the node can use a location service such as the Reactive Location Service (RLS) [175], the Grid Location Service (GLS) [176], or the Hierarchical Location Service (HLS) [161–163]. This kind of routing is the most suitable for highly dynamic networks such as UAANETs. Below we investigate in details the most relevant routing protocols belonging to this category.

3.12.1 Reactive-based routing protocols

The reactive technique is the most used technique in UAANET routing protocols. Indeed, when there is no route to the target destination, the source node needs to establish an on-demand path in order to start a communication with the target destination. Many reactive routing protocols are proposed for UAANETs.

Shirani *et al.* proposed Reactive-Greedy-Reactive protocol (RGR) [177], which is a reactive routing protocol based on the combination of a topology-based routing protocol to create on-demand paths using the well-known reactive protocol AODV (Ad hoc On-demand Distance Vector) [149], and a classic delivery technique based essentially on the Greedy Geographic Forwarding (GGF) [177]. To illustrate the functionality of RGR, we have to describe its discovery process. Indeed, when a source UAV S has a data packet to send to a destination UAV D , it initiates a path discovery process (*same as AODV*) in order to find a connected path to reach the target destination by flooding Route Request (RREQ) over the network. As soon as the Route Reply (RREP) is received by the source from the destination UAV, it

starts the data delivery.

The novelty in RGR is that the geographic position of the destination UAV D is cached in the routing table (maintained periodically based on Hello packets) of each intermediate UAV traversed by the RREP packet when it is sent back to the source. As a recovery strategy, an intermediate node may detect a disconnection with the next forwarding node due to high mobility, which signifies the failure of the discovered path. In this case, RGR switches to GGF mode and forwards the packets to the closest neighbor UAV to UAV D until reaching it. If GGF fails to find the next forwarding UAV, the packet will be dropped. In parallel, a Route Error (RERR) will be sent to the previous node until reaching the source node. If the source node has more data packets to transmit, it initiates a new path discovery so as to create a new reactive path to the target destination.

Sakhaee *et al.* proposed MULTipath DOPpler Routing (MUDOR) [178, 179], which is a reactive routing protocol inspired from Dynamic Source Routing (DSR) [148] and designed for highly mobile ad hoc networks like UAANETs. MUDOR is based on the selection of the most stable path with the longest lifetime. To find the best path, MUDOR measures the frequency shift due to the Doppler effect of the received packets. This determines the relative velocity between the source and the destination aerial vehicle. Then, we can estimate the lifetime of the link. Before starting the data delivery, MUDOR uses the flooding of RREQ to discover routes toward the target destination. The first time when a node receives the RREQ packet; it rebroadcasts this packet after adding its identifier and the Doppler value from the previous node. At the end, the destination will reply with a RREP packet through the path with the longest lifetime by considering all the calculated Doppler values.

In fact, the discovery phase is the only way to get the most stable path using the estimated Doppler values for each discovered path. To be more clear, as soon as the target destination makes the routing decision, it replies with a RREP packet through the succession of nodes, where their velocity vectors are in the direction toward the destination itself and their speeds are relatively the same. Once the source node receives the RREP, it starts the data delivery. Indeed, the source node S selects the same sequence of nodes transited by the RREP packet depending on their velocities and speeds resulting in long lifetime links between them. Consequently, the selected path has a long duration of life and MUDOR made time to initiate a new path discovery.

Iordanakis *et al.* proposed Ad hoc Routing Protocol for Aeronautical Mobile ad hoc networks (ARPAM) [180], which is a routing protocol based on the geographical positions. ARPAM has the same principle as in AODV [149], and consequently, is partly reactive. ARPAM uses geographic positions of UAVs in the network to select the shortest path between the source UAV and destination UAV. Similarly to AODV protocol, when a source UAV wants to send data packets and there is no path to the destination UAV, a RREQ packet is flooded over the network. The RREQ contains the velocity vector and the position of the source. This information is used

by intermediate UAVs to estimate the current position of the source UAV, which is changing rapidly due to the high speed of the UAVs. Also, the geographical position and velocity vector information can be used to provide the distance that the packet has transited which can be used as a metric during the routing path decision. When the destination receives the RREQ packet, it responds with a RREP packet which is sent unicastly to the source node. ARPAM is also based on an on-demand path maintenance mechanism, which aims to maintain routing tables when necessary, and especially, for certain applications such as voice over IP (VoIP) or video on demand (VoD), which requires low response times from the network. Consequently, ARPAM is a reactive routing protocol which can be proactive on-demand.

As an illustration, we take the example of the discovery phase executed by the source node. Indeed, when the source node UAV S wants to send a data packet to destination UAV D , it broadcasts a RREQ packet in the network, which includes the geographic position and velocity vector of the source. Once UAV D receives the RREQs packet, it selects the closest path to the source based on the information included in the received RREQs. When a path is selected, UAV D sends unicastly a RREP packet back to UAV S through the selected path. Once the source UAV S receives the RREP packet, it starts the data delivery to the target destination through the same path transited by the RREP packet.

3.12.2 Greedy-based routing protocols

As a forwarding strategy in a classical UAANET position-based routing protocol, the technique of greedy forwarding is frequently employed for data packet delivery. This technique aims to minimize the number of hops to the target destination, and consequently, the delay of delivery. Some of the well-known approaches proposed for UAANETs are presented in this section.

Lin *et al.* proposed Mobility Prediction based Geographic Routing (MPGR) [181], which is a routing protocol based on the geographic positions for inter-UAV communications. The same principle in GPSR (Greedy Perimeter Stateless Routing) [182] is used in MPGR. Furthermore, MPGR uses a mobility prediction method based on the Gaussian distribution function so as to reduce the impact of the high mobility of UAVs with an acceptable communication overhead. The novelty in MPGR is when a source UAV wants to send a data packet, firstly, it must broadcast a Neighbor Discovery packet (ND) to know the available next forwarding UAVs and to select the appropriate one based on the information included in the Reply Packet (RP). However, the selected next forwarding node can move out of the source transmission range causing the loss of the data packet due to the link interruption. In this case, MPGR uses the mobility prediction to predict the accurate geographic location of UAVs at time t_n based on the mobility feature and position at t_{n-1} . The estimated position allows the analysis of the persistent connection of the neighboring nodes. Thus, we can perform the selection of the next forwarding node more accurately.

The selection of the next forwarding node, which is carried out by the source or the current node is based on a metric called Reliable Next Hop (RNH). This metric combines the estimated position and speed of the current node and its neighbors, and also the distance and time of persistence between each pair of nodes. The smaller is the value of RNH, the better is the next hop. RNH is calculated based on the following formula:

$$RNH_A(D) = \begin{cases} d_A + \frac{\eta}{\Delta T}, & (d_A < d_B) \wedge (\Delta T \geq 1) \\ Max_value, & \text{otherwise} \end{cases} \quad (3.1)$$

where d_A and d_B are the distances between a UAV A and destination UAV D , and between a UAV B and D , respectively. RNH_A is the calculated metric of the neighbor A for the destination D . The ΔT is the maximum persistence time of the forwarding neighbor A . η is a factor used to adjust the neighbor connection persistence which is set within the range $(1, R)$, where R is the transmission range. Max_value is the maximum value which has to take RNH metric. As an example, if an intermediate UAV detects a routing void (*i.e.*, it is the closest to the destination UAV D), the greedy forwarding mode will fail and MPGR has to switch on perimeter forwarding. The current UAV calculates the distance between each two-hop neighbor and UAV D . In the case when a UAV is found, it will be selected as a forwarding node because it has a neighbor node which is the closest to UAV D .

Lin *et al.* proposed Geographic Position Mobility Oriented Routing (GPMOR) [183], which is a routing scheme dedicated for UAANET. GPMOR uses the mobility prediction of UAVs that move based on Gauss-Markov mobility model [184]. Indeed, each UAV has the knowledge of its own geographical location with the help of the GPS. Each UAV periodically exchanges its position with its direct neighbors trying to predict the movement of its neighboring nodes and to define their new positions during a time interval. Consequently, it is possible to select the suitable forwarder towards the destination UAV which can itself change position occasionally.

According to its functionality, GPMOR can carry out the best forwarder selection based on the adopted prediction method. For instance, the source UAV S can select another UAV as a forwarder of the data packet if and only if it is the most appropriate UAV according to its future movement, which is towards the destination UAV D . However, if the next forwarder UAV can move away from the transmission range of UAV S , it will not be selected as a next relay because it may result in the loss of data packets due to the high mobility of the nodes. Once the destination D is within the communication range of the selected forwarder UAV, the data packet is automatically delivered to its corresponding destination.

Medina *et al.* proposed Geographic Load Share Routing (GLSR) [185–188], which is a geographical routing protocol for UAANET. GLSR is an extension of the protocol GPSR [182] which operates the multiple paths between source and destination. The idea behind GLSR is to simultaneously use multiple paths between source and destination. The key principle of GLSR is to send data packets to the nodes, which

allow approaching to the destination. To this end, GLSR defines the *distance advance* (a_K^M) that permits a neighbor UAV K to reach a destination M . a_K^M is calculated based on the difference between distances of a current UAV I and the neighbor UAV K from the destination UAV M as follows:

$$a_K^M = \delta_{IM} - \delta_{KM} \quad (3.2)$$

If a_K^M is positive, the neighbor UAV K allows to reduce the distance to the destination UAV M . Then, GLSR determines the best path among the different available paths. For this, each node has multiple queues for packets to send. Furthermore, there is a queue for each neighbor. GLSR takes into account the degree of filling of these queues to determine the best path. The metric used to select the best neighbor is called the *speed of advance* v_K^M of the neighbor UAV K toward the destination UAV M as follows:

$$v_K^M = \frac{a_K^M}{Q_{IK.size} + 1} \quad (3.3)$$

Where Q_{IK} is the neighbor UAV K queue size using Self-organized time-division multiple access (STDMA) link scheduling. This favors the nodes that have the highest speed of advance and the lowest queuing delay to be selected to deliver data packets toward the destination UAV M .

Similar to GPMOR, the forwarder UAV K checks periodically in its neighborhood to find, if possible, another suitable node to the target destination with the previously mentioned characteristics by using the same equations 3.2 and 3.3 to determine the next hop. Finally, when the destination is within the communication range of the UAV K , the data packet is delivered directly to its corresponding destination.

3.12.3 Delay-tolerant-network-based routing protocols

In some cases, a UAANET becomes partitioned due to the high degree of mobility nodes. This category of protocols uses the technique of store-carry-and-forward to transmit data packets to the target destination. This technique decreases significantly the overhead since it does not use any additional control packets. However, it increases the delay of transmission since data packets are transited based on the movements of nodes. Some protocols are presented in this section.

Kuiper *et al.* proposed Location Aware Routing for Opportunistic Delay Tolerant (LAROD) [189], which is a delay tolerant geographical routing protocol based on the combination of the store-carry-and-forward and greedy forwarding techniques according to the network situation. In addition, a beacon-less strategy is used, which reduces considerably the overhead with the help of the network management.

The data delivery is the key part of the LAROD functioning. Indeed, when a source UAV S wants to send a data packet to a destination UAV D , it broadcasts it to the neighboring nodes. When it is received by each one, intermediate nodes start

a timer. The best forwarding node, which is the first one having the timer expired, it forwards the data packet in the same manner. The source UAV S will overhear this transmission and deduct that the forwarder has successfully received the data packet and broadcasted it. If no transmission is heard, UAV S periodically broadcasts the data packet until a node becomes available. However, if the network is sparsely connected, the current UAV (*i.e.*, the custodian) uses the store-carry-and-forward technique by holding the data packet until it meets other UAVs nearby. In this case, it uses the greedy forwarding to resume the data packet delivery until it reaches the destination UAV D . When the data packet is successfully received by UAV D , an acknowledgment (ACK) is broadcasted back to the source.

Jabbar and Peters *et al.* proposed Aeronautical Routing Protocol (AeroRP) [190, 191], which is a geographical delay tolerant routing protocol designed for aeronautical networks which consist of fast aerial vehicles (*e.g.*, *Aircraft*). The first phase of the AeroRP's functionality is to detect the neighboring nodes by intercepting their positions and velocities. This information is updated through the periodical exchange of Hello packets. Based on the neighbors' table, each node calculates for its neighbors a metric called Time to Intercept (TTI) which is used to select the next forwarding node. TTI indicates when a potential neighbor will be within the communication range of the current node. TTI is calculated based on the following formula:

$$TTI = \frac{\Delta d - R}{S_d} \quad (3.4)$$

Where R is the transmission range of each neighbor. Δd is the distance between the specific neighbor and the target destination. S_d is the velocity of the specific neighbor in which it moves towards the target destination.

The keystone of AeroRP is that when a source airborne vehicle S has a data packet to send to the destination D , it has to select the fastest next forwarder or custodian among its neighboring nodes moving towards D . S calculates its own TTI (*i.e.*, if its velocity is towards D) and those of the neighboring nodes. The neighbor node that obtained the lowest TTI is selected to hold the data packet. However, if S obtains the lowest TTI from D or all nodes are moving away, S continues to keep the data packet. If a neighbor node obtains the lowest TTI and it will be selected to hold the data packet.

Hyeon *et al.* proposed Geographic Routing protocol for Aircraft Ad hoc Network (GRAA) [192], which is a geographic routing protocol based on GPSR. The routing decision is taken locally at each intermediate node. To determine the next hop, each node takes into account the position and the velocity of its neighbors and destination. Initially, the current node calculates the estimated position of the destination after a time period t based on its current position and speed. Then, it calculates the estimated position of each of its neighbors, according to the same time t . The node with the closest estimated position to that of the destination after time t is selected for the next hop.

To give a deeper understanding of the next relay selection, we provide a concrete

scenario when the source node UAV S selects the next hop according to the predicted position of its neighbors UAV J and UAV K and the destination node UAV D estimated after a time Δt . We suppose that the predicted position of the neighbor node J will be closer than neighbor K to the destination UAV D after time Δt . Therefore, the node UAV J will be selected as the next hop to deliver the data packet to the destination UAV D . However, when the network is sparsely connected and there are no neighboring nodes, UAV S continues to keep the packet until the target destination D .

3.12.4 Heterogeneous routing protocols

In this category, nodes on the ground can be assisted by UAVs to improve the robustness and reliability of the data delivery. In addition, UAVs can be used as one team to accomplish certain tasks (as mentioned before) or to be used as sensors for different applications. Some protocols are presented here.

Le *et al.* proposed Load Carry and Deliver Routing (LCAD) [193], which uses a new mechanism in UAV ad hoc networks using UAVs to enhance the connectivity. In this protocol, the technique of store-carry-and-forward is used uniquely by the UAVs in order to improve efficiently the connectivity and packet delivery between two different routing protocols: Disruption Tolerant Network (DTN) in the sky and Ad hoc On Demand Distance Vector (AODV) [149] on the ground. The major disadvantage of this protocol is that UAVs do not use GPS information and trajectory calculation during route discovery and data forwarding.

To clearly describe the functioning detail of LCAD, we take an example of its data delivery process. Indeed, when a source node (base station) has a data packet to send, it starts a discovery process on the ground until it gets at least one path to the target destination. If there is no path to the target destination, it means that the destination is located in another area. In this case, LCAD will rely on the existing UAVs in the sky to deliver the data packet to the area where the destination is located using the store-carry-and-forward technique.

Oubbati *et al.* proposed Connectivity-based Traffic Density Aware Routing using UAVs for VANETs (CRUV) [8], which is the improved version of [159, 194]. It is a delay tolerant protocol based on the periodic exchange of Hello packets between vehicles. This exchange allows vehicles on the ground to calculate the most connected segment among their neighboring segments. Then, the connectivity information about their neighboring segments will be shared with the existing UAVs, in order to have a global vision of all the segments around. When there are data packets to deliver, UAVs exchange this information with all vehicles located at each intersection to allow them to take an efficient routing decision. In addition, UAVs can be selected as forwarding nodes in the case when the network is sparsely connected.

When a source vehicle wants to send a data packet to a destination vehicle based on

the UAVs in the sky. The source vehicle selects a UAV to deliver the data packet when there is a connected segment. The UAV checks if there is a connected segment around, if yes, this segment will be selected to deliver the data packet. Otherwise, the data packet will be sent directly to the target destination if it is within the transmission range of the UAV. In the case if the current vehicle is not located at an intersection, CRUV first tries to get the closest intersection in order to start calculating scores for different segments around. If there is at least one connected segment, it will be selected to forward the data packet. Otherwise, the closest UAV in range will be selected to transmit the data packet to the target destination. Nevertheless, when no forwarder is found, the current node will carry the packet until a possible neighbor is found in order to submit the carried data packet to it.

As a drawback, CRUV does not take into account the real distribution of vehicles on the selected segments which is very crucial to measure connectivity factor. Furthermore, when there is a disconnection, CRUV will use the store-carry-and-forward technique as a recovery strategy resulting in an important delay in delivering.

3.13 Comparative study of UAANET routing protocols

The routing protocols differ from each other by taking into consideration specific parameters. As shown in TABLE 3.2, the UAANET routing protocols are categorized according to the used delivery strategies. In addition, we clarify the different assumptions made by each protocol and the methods used for evaluating their performances. In order to classify the UAANET routing protocols, we use several crucial criteria such as data delivery strategies, assumptions, evaluation features, and the calculated performance metrics. These criteria can make the difference between the proposed position-based routing protocols for UAANETs. Following are the descriptions of these criteria.

Data delivering strategy

The strategies used by each protocol both in the data delivery and the recovery process can determine to which category the protocol belongs.

- **Store-carry-and-forward:** aims at keeping a data packet by the current node, which has no immediate neighbors to deliver the data packet. It is carried until that the target destination moves into the transmission range of the current node.
- **Greedy forwarding:** the main idea consists of selecting the geographically closest next forwarder to the target destination. This process is done by the

current node and repeated by intermediate nodes until that the data packet reaches the destination.

- **Path discovery:** it is among the most used techniques. Its principle is to broadcast the message by each node receiving for the first time this message except the target destination.
- **Single path:** consists of establishing between each pair of nodes (Source/Destination) the shortest path in ad hoc networks. This kind of strategy is considered as more complex than multi-path routing.
- **Multi-path:** is more appropriate for highly dense networks in which there is more than one path between each pair of nodes (Source/Destination).
- **Predictive:** some routing protocols assume that the mobility characteristics are exploited in the routing process. The current and the future geographical locations of nodes are predicted based on several metrics such as the velocity and the last known location of each node, this method is efficient to have an accurate robust routing path.
- **Recovery strategy:** is defined as a method to avoid a critical functioning of the routing protocol and to continue working normally.

Assumptions

Each protocol can suppose different assumptions for the right functionality of its own mechanism. Most of the proposed protocols take into account at least one of the following assumptions.

- **Location service:** each node can use a location service to calculate the geographic position of each node (especially destination nodes) in the network.
- **GPS:** allows each node to define its own geographic location and to determine the neighboring locations.
- **Neighbor table:** is a table included in each node which contains information about the neighboring nodes (*i.e.*, position, speed, trajectory, *etc.*).
- **Infrastructure:** each node is able to communicate with existing infrastructures on the ground in order to get or to transmit certain information. In certain situations, infrastructures can be in the form of base stations or access points where it is indispensable that mobile nodes have to exchange data with them.
- **Environment awareness:** each node in the network should have a global vision about the region where a routing protocol is applied. This vision allows routing protocols to avoid certain constraints like obstructions which prevent direct communications between the nodes resulting in frequent disconnections and packet losses.

Evaluation features

Each proposed protocol has to be tested, validated, and classified according to its drawbacks, kind of nodes, and the obtained results from the simulation.

- **Mobility models:** are the generated movements which can be classified according to each kind of model. The type of mobility is selected based on different criteria such as scenarios, environments, and applications.
- **Mobility generator:** is the tool used to generate the movements of each node in the simulation scenario. Generally, in most cases, it is the same tool used for the simulation.
- **Simulation tool:** is the main tool used for coding the algorithms of each routing protocol. It may vary from a protocol to another, depending on the used techniques which require certain packages or functionalities.
- **Evaluation metrics:** are the different metrics calculated in each simulation scenario for each routing protocol to study its behavior and to compare them with other protocols using the same calculated metrics. These metrics differ from a protocol to another according to the used techniques and strategies.
- **Latency:** is defined as the time needed to deliver data between two pairs of nodes (Source and Destination) when the routing protocol is based on a special strategy. Particularly for real-time applications such as video monitoring, which needs constant delay where the data packet has to be transferred to the target destination.
- **Drawbacks:** are the major limitations found in each routing protocol concerning its functioning or is deducted from the evaluation results of the protocol. The main drawbacks found are the problem of disconnection, congestion, and overhead, which are caused by different factors such as the applied data delivery strategies, the control packets, and their broadcasting frequency.
- **Type of the network:** is the environment and kind of nodes where the routing protocol can be deployed to support its communications or its data exchanges. In certain cases, the network can be heterogeneous (*i.e.*, many types of nodes can exchange data packets between each other).

Performance metrics

Generally, six major metrics are used to evaluate the performances of the FANET routing protocols [9]:

1. **Packet Delivery Ratio (PDR):** defined as the ratio of packets successfully delivered. *i.e.*, the percentage of all data packets received by the receiver to all data packets generated from the senders. The bigger is *PDR*, the better is the performance of the protocol.
2. **Average End-to-End Delay (EED):** the average time for data packets to reach the target destinations. It also includes the time taken by the discovery process in the case of reactive protocols, and the tail of data packets delivering. Only the data packets successfully received and generated are counted. The smaller is *EED*, the better is the performance of the protocol.
3. **Average number of Hops (H):** number of data packets delivered divided by the number of hops performed by all packets. As a general idea, consumption of resources increases as the number of hops increase. The smaller, the better.
4. **Overhead (O):** ratio of control routing packets to the successfully delivered packets at receivers. This metric shows the degree of saturation of the network. The lower, the better.
5. **Throughput (T):** number of data packets successfully delivered to the target destination during a given amount of time (generally 1 (s)). The bigger is *T*, the better is the performance of the routing protocol.
6. **Latency (L):** the measure of time taken by a data packet to transit between a pair of nodes in a given network. The lower, the better.

All these criteria are the most distinguished in the studied routing protocols dedicated for UAANETs. From this comparative study, we deduct that a new proposed routing scheme has to avoid as much as possible all drawbacks distinguished in the discussed protocols while taking into account a minimum of assumptions. In addition, reasonable evaluation features and adequate metrics of performance have to be defined for each kind of newly proposed routing schemes.

Table 3.2: UAANET position-based routing protocols (comparative study).

Parameters	UAANET position-based routing protocols										
	Reactive-based			Greedy-based			Delay tolerant (DTN)			Heterogeneous	
	RGR	ARPAM	MUDOR	MPGR	GPMOR	GLSR	LAROD	AeroRP	GRAA	LCAD	CRUV
	Ref.[177]	Ref.[180]	Ref.[179]	Ref.[181]	Ref.[183]	Ref.[188]	Ref.[189]	Ref.[190]	Ref.[192]	Ref.[193]	Ref.[8]
Store-carry-and-forward	No	No	No	No	No	No	Yes	Yes	Yes	Yes	Yes
Greedy forwarding	Yes	No	No	Yes	Yes	Yes	Yes	No	No	No	Yes
Path discovery	Yes	Yes	Yes	No	No	No	No	No	No	Yes	No
Single path	No	No	No	Yes	Yes	Yes	Yes	Yes	Yes	No	Yes
Multi-path	Yes	Yes	Yes	No	No	No	No	No	No	Yes	No
Predictive	Yes	No	Yes	Yes	Yes	No	No	Yes	Yes	No	No
Recovery strategy ¹	GF	Recalculate path		T-HPF	Movements prediction		Store-arry-and-forward			Store-carry-and-forward	
Location service	✓	×	✓	✓	✓	✓	✓	✓	✓	✓	✓
GPS	✓	✓	✓	✓	✓	✓	✓	✓	✓	✓	✓
Neighbors Table	✓	✓	✓	✓	✓	✓	×	✓	✓	✓	✓
Infrastructure	×	×	×	×	×	✓	×	✓	✓	✓	×
Environment awareness	×	✓	×	×	✓	✓	×	✓	✓	✓	✓
Mobility model ²	Modified RWP	RM		Gauss-Markov		RM	PR	RWP		—	MM
Mobility generator	OPNET		JAVA	NS-2		OMNeT++	—	NS-3	—	NS-2	MobiSim VanetMobi-Sim
Simulation tool	OPNET		Aero-MANET	NS-2		INET	NS-2	NS-3	QualNet	NS-2	
Evaluation metrics ³	P, D, O	P, T, L	P	P, D, O	P, D, H	P, D, T	P, O	P, D, O	P, D	P, T	P, D, H
Latency	Low	Unknown		Low			High			High	
Drawbacks ⁴	GFL, O, C	O, C		NEL, C	C	IFL, D	D, C	IFL, D	IFL, D	O, C	D, O
Type of network	UAANET	UAANET	UAANET	UAANET	UAANET	UAANET	UAANET	UAANET	UAANET	UAANET-MANET	UAANET-VANET

¹Recovery Strategy: T-HPF: Two-Hop Perimeter Forwarding, GF: Greedy Forwarding.

²Mobility model: RWP: Random Way Point, RM: Random Movements, PR: Pheromone Repel and MM: Manhattan Model.

³Evaluations metrics: P: Packet Delivery Ratio, D: End-to-End Delay, O: Overhead and H: Average number of hops.

⁴Drawbacks: GFL: Greedy failure, O: Overhead, C: Congestion, D: Delay, NEL: No expiration links and IFL: Infrastructure failure.

3.14 UAANET-to-VANET communications

UAVs are composed of a variety of essential devices, providing various functionalities such as wireless communications, controlled movements based on algorithms, and a global knowledge about the ground activities. This kind of intelligent nodes can be the suitable choice to improve the connectivity and to serve terrestrial mobile nodes [195]. Hence, air-to-ground communications allow to exchange information with nodes located on the ground, to direct and coordinate its actions from the air, and guaranteeing a high level of radio coverage, which is not always ensured by terrestrial mobile nodes. Therefore, this kind of communication is beneficial to develop more intelligent connected nodes in the future using UAVs.

The last three years (*i.e.*, since 2014), scientists opened a new avenue of research in the possibility to use UAVs to improve connectivity in VANETs and coordinate specific actions. It is expected that UAV-to-VANETs communications will make it possible to surpass the constraints detected in a conventional VANET (*c.f.*, Figure 3.6). Finally, we can say that UAV-to-VANETs communications are also among the worthwhile research issues to take into account.

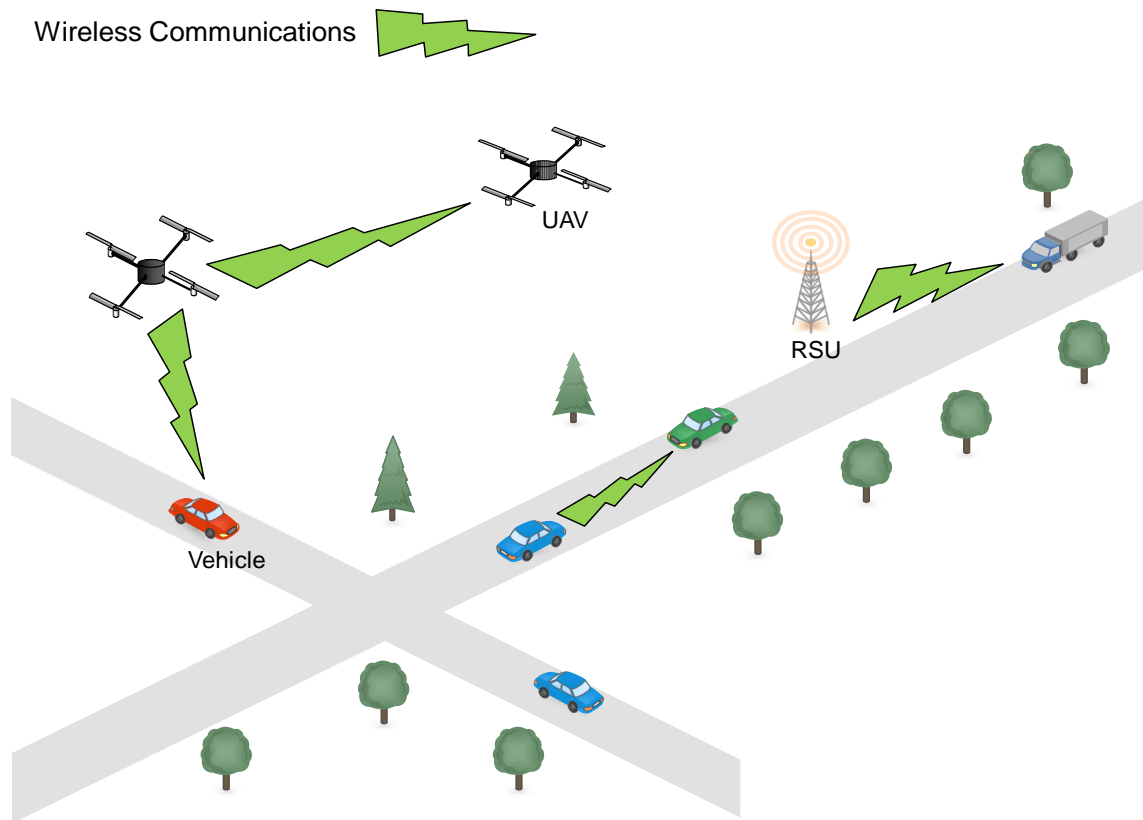

Figure 3.6: UAV-to-VANETs communications.

3.15 Conclusion

In the present *chapter*, we have described the concept of routing in both VANETs and UAANETs. A number of routing techniques adopted in such networks are detailed. Furthermore, according to the adopted technique, the routing protocols proposed in VANETs and UAANETs are classified. Because of the high mobility of these networks, topology-based routing protocols are not suitable since they ignore this crucial detail and their other unique characteristics. However, we have demonstrated that position-based routing protocols are the most adequate to handle the high mobility and the frequent disconnections which characterize these networks.

In this context, the most popular position-based routing protocols proposed for VANETs and UAANETs are illustrated. The problem of routing in these kinds of networks is far from clear. The difficulty lies mainly in the instability of the routing paths caused by the high mobility of the nodes and the frequent fragmentation of the network. Another aspect of the problem is that position-based routing protocols dedicated for VANETs pose problems in the case of communications in environments where there are obstacles (*e.g.*, buildings, *etc.*) and partially connected segments as in an urban environment. As for UAANETs, despite the fact that the problem of obstacles does not appear in the sky, but we have distinguished several other issues such as the unpredictable movements of UAVs and the frequent disconnections. At the end of this *chapter*, we have introduced a novel communication scheme between UAANETs and VANETs to improve the routing process between them. This cooperation can be a promising architecture to resolve the issues and surpass the constraints distinguished in these kinds of networks.

In the next three *chapters*, we introduce our routing schemes dedicated for urban VANETs, which are assisted by existing UAVs in the sky in order to improve the routing process. First, a delay tolerant network routing scheme is presented in which UAVs partially assist the data exchange between vehicles on the ground. Second, the UAVs are fully exploited by introducing two routing components in the sky and on the ground. Finally, a reactive method which considers that UAVs as full members in VANETs allowing to increase the number of alternative solutions in the case of routing path failures.

Chapter 4

CRUV–Connectivity-based Traffic Density Aware Routing using UAVs for VANETs

Contents

4.1	Introduction	68
4.2	Assumptions	69
4.3	System model	70
4.4	Scoring system	72
4.4.1	Hello packet format	72
4.4.2	Score calculation	73
4.5	Path selection	76
4.6	Performance Evaluation	78
4.6.1	Simulation Model	79
4.6.2	Evaluation metrics	80
4.6.3	Results Analysis	81
4.7	Conclusion	84

4.1 Introduction

Most of the routing protocols proposed for VANETs tend to address the problem of frequent disconnections distinguished in this kind of networks. This can be done by finding the most connected end-to-end path to successfully deliver data packets to their destinations with a reduced end to end delay. However, most existing protocols do not fully consider the impact of the existing obstacles that can affect directly

the performance of the routing, and therefore, impact the communication between vehicles.

The advent of commercial drones or UAVs is expected to facilitate the deployment of a plethora of UAV-based applications. As a result, we expect UAVs to cooperate in ad hoc fashion and joint VANETs in order to avoid existing obstacles on the ground and to have a global vision of the connectivity between vehicles. In this *chapter*, we propose a novel routing scheme for VANETs called CRUV (Connectivity-based Traffic Density Aware Routing using UAVs for VANETs) [8]. The main idea of this approach is to use UAVs through cooperative and collaborative communication. Our approach is based on information exchange between vehicles and UAVs to help vehicles on the ground find the best multi-hop path by selecting the most appropriate next intersection to deliver the data packets successfully to their destinations. We use the real-time traffic variation which is estimated with a completely distributed manner based on the periodic exchange of Hello messages between all vehicles and UAVs in the system. In addition, we aim at integrating Vehicle-to-UAV (V2U) communications to make routing in the presence of UAVs more efficient and more reliable. Consequently, this can be a promising solution to ensure packet delivery with a minimum of packet losses and end-to-end delay. This approach is beneficial to develop more intelligent connected nodes in the future.

4.2 Assumptions

The main objective of CRUV is to find the shortest and the most reliable segment among others available beforehand based on a score calculated permanently by the vehicles situated at the intersections for all the segments around. In addition, the UAVs have a global vision of all the intersections surrounding them (in range). Consequently, the UAVs can immediately deduct the most connected segments based on the best scores given at each intersection, which are shared through the periodical exchange of Hello messages by the vehicles located at the intersections. The vehicles can select a UAV as a forwarding node instead of road segments in the case where the UAV detects a score on another intersection better than calculated by the vehicle located at the current intersection.

This new routing protocol mainly relies on choosing, at each moment and ahead of time, the most connected path among others available and avoid available paths that can be quickly broken. Connectivity paths are done and undone due to the high mobility of the vehicles and to the encountered obstructions and obstacles. A path is considered most connected based on the degree of traffic density and connectivity of the vehicles within a road segment. A path connectedness can be measured based on several possibilities: (i) through periodic Hello messages exchanged between vehicles, (ii) by forwarding the data packets directly to UAVs within range when there are no available routing paths, and then, forward the data packet directly to the destination

if it is within the transmission range of the UAV, or (iii) through the vehicle located at the most appropriate intersections where there are available connected road segments leading to the destination. This scheme overcomes the presence of obstacles when calculating the traffic density, connectivity, and the data packet delivery.

For the right functionality of our routing approach, several assumptions are considered as follows:

- All the vehicles and UAVs are equipped with a Global Positioning System (GPS) and with an embedded digital road map to locate the neighboring intersections.
- The knowledge of the destination's position is assumed to be known thanks to the GLS (Grid Location Service) [176].
- A table of neighbors is maintained and updated periodically by all vehicles and UAVs.
- All UAVs always have enough battery power.
- A vehicle can communicate with UAVs and other vehicles within a line-of-sight (LoS).
- The format of hello message is modified by adding new fields in order to allow vehicles to calculate the total number of vehicles and to have a global vision of the connectivity between two successive intersections and to share them with the existing UAVs that can then participate to make the routing decision carried out by the (source/forwarder) vehicle located at the intersection.

4.3 System model

The system is composed of vehicles and unmanned aerial vehicles (Commercial-Quadcopters) distributed equitably on the network.

- Each vehicle has a long range WiFi interface for communication with other vehicles (V2V) on the same street. However, the communication cannot be established between vehicles located on different streets, which are not opposite from each other due to the presence of obstacles. Also, vehicles can communicate with all UAVs within transmission range.
- The UAVs are able to communicate and to fly autonomously without human interaction. The transmission range of the UAVs is supposed to be sufficiently large for air-to-ground communications (V2U), so they will not be affected by the obstacles (*e.g.*, buildings) since they can fly high enough (*c.f.*, Figure 4.1). We note that we treat the range of all the vehicles and UAVs as the same when the communications need to be established between them.

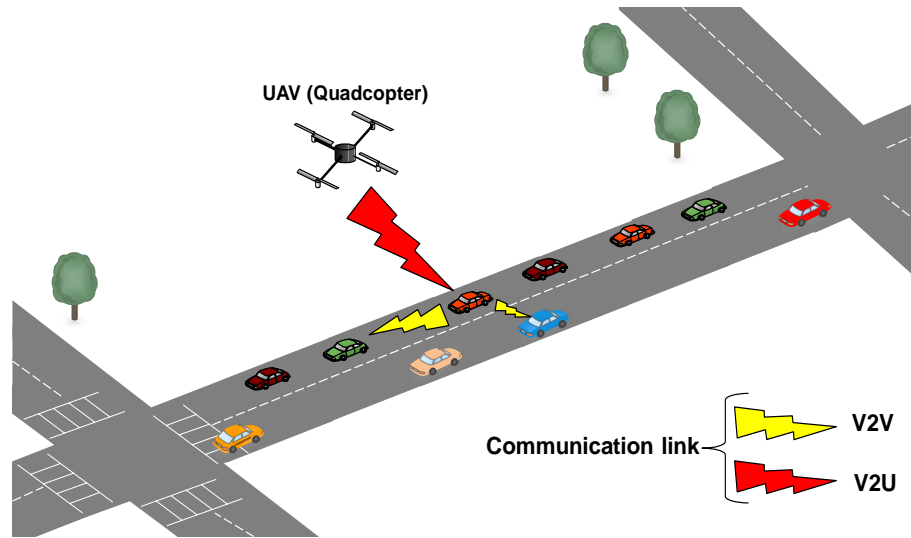

Figure 4.1: Communication architecture of CRUV.

- To ensure delivering a data packet to its destination, one of the four following states (*c.f.*, Figure 4.2) is considered to be run depends on the situation of the network and the location of the (forwarder/source) vehicle: (i) Path selection, (ii) Greedy forwarding, (iii) Store-carry and forward, and (iv) UAVs.

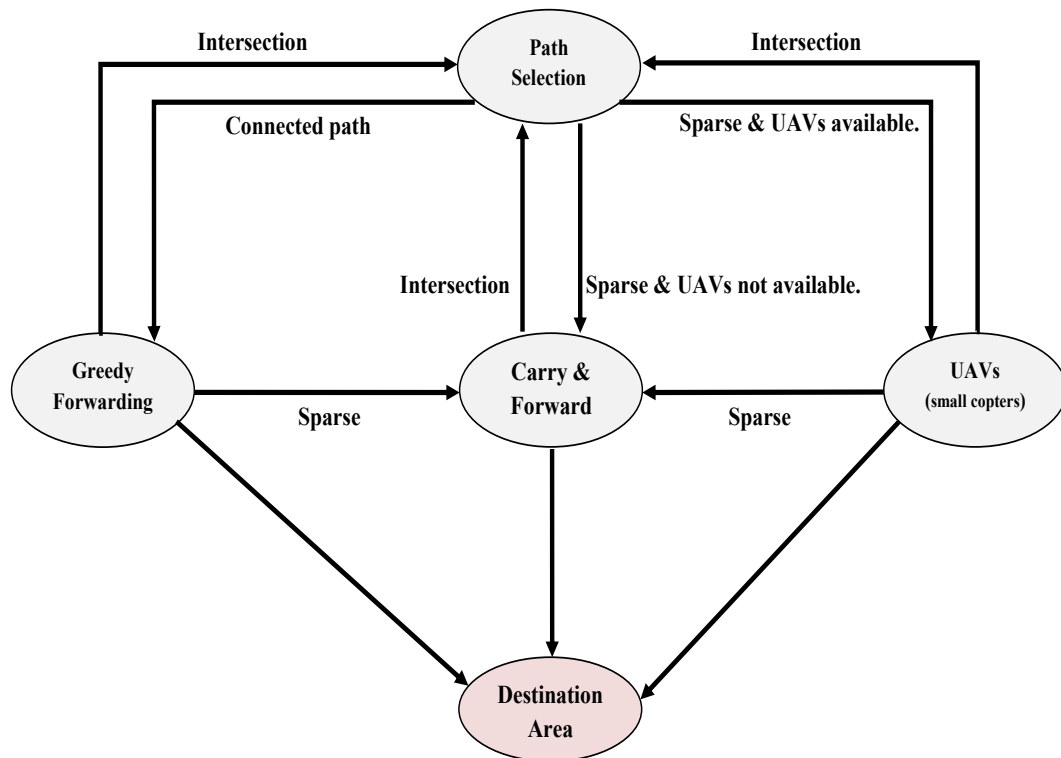

Figure 4.2: CRUV states.

Therefore, CRUV uses Greedy Forwarding and Store-carry and forward as data delivery mechanisms according to the situation of the network. The path selection is carried out uniquely at the junctions because they are the only places where a routing decision is taken based on the traffic density estimation and the shortest path to the final destination. UAVs are used only to deliver data packets when they detect a best score somewhere in another intersection or when there are no available connected road segments. All these states can lead directly or indirectly to the destination state, which represents the target destination of the transited data packets.

4.4 Scoring system

The score is calculated based on the traffic density and the knowledge of the connectivity on the road segment. These two metrics are calculated in a completely distributed manner using the periodical exchange of Hello messages between vehicles located on the same road segment. This process is carried out permanently in all road segments of the network.

4.4.1 Hello packet format

To correctly estimate the score for each road segment, we have added new fields in the Hello message format in order to allow both vehicles and UAVs to calculate and to broadcast the best score obtained in each road segment.

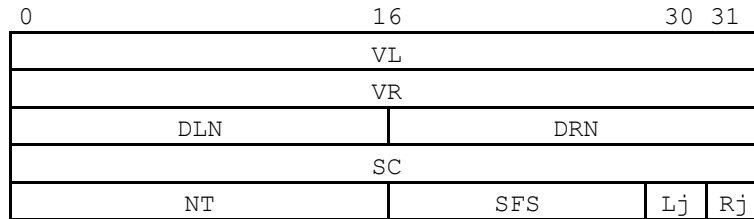

Figure 4.3: Additional fields in the Hello packets.

The new modified Hello message format as shown in Figure 4.3, contains the node type (NT) (*e.g.*, Vehicle or UAV) mainly used to define which fields we have to take into consideration. It also contains the number of one-hop neighbors situated on the left (DLN) and the right (DRN), the total number of vehicles located on the left (VL) and the right (VR) until the next intersections, two flags (L_j and R_j) to indicate the existing connectivity between two successive intersections, the best score between all the scores calculated at the current intersection or intercepted from the UAVs (SC), and finally the selected forwarding solution (SFS) (*e.g.*, UAV or road segment).

4.4.2 Score calculation

Each vehicle broadcasts the connectivity information which indicates whether or not we can reach the left or right intersection and also calculates and broadcasts the total number of vehicles upon receiving a Hello message from the farthest neighbors located at the left and the right (*c.f.*, Figure 4.4). Then, the neighboring nodes will re-broadcast the Hello message to their neighboring nodes. The process is repeated until the Hello messages are intercepted by the vehicles at the ends of the segment (*i.e.*, intersection L_j and R_j). As shown in Figure 4.4, **A** is a vehicle located on the road segment and it participates at the estimating of the traffic density. Vehicle **A** intercepts the Hello messages broadcasted by the vehicles situated on the left and the right in which it learns the number of the vehicles located at the left and the right respectively and the connectivity information.

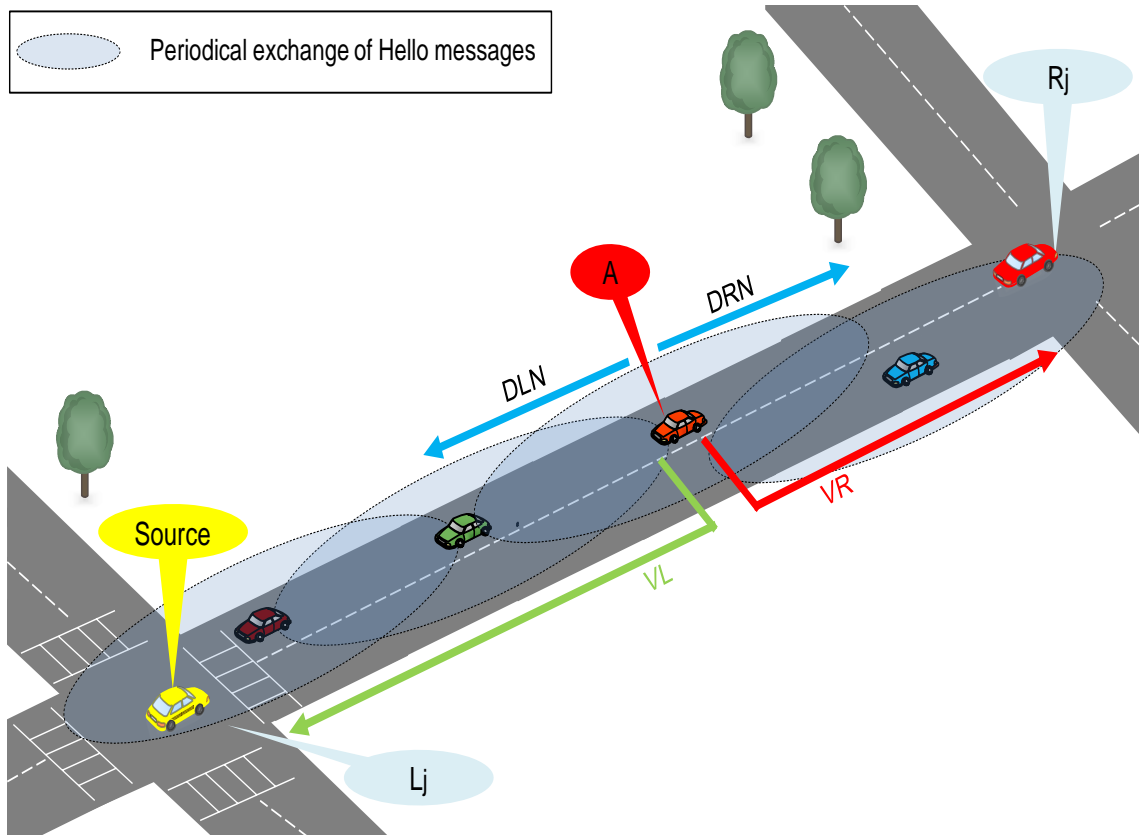

Figure 4.4: The score's calculation.

Based on the intercepted Hello messages, the vehicle **A** broadcasts a hello message to all its neighbors which it contains much information (*see* Figure 4.5).

When the source vehicle (*i.e.*, yellow vehicle in Figure 4.4) located at the intersection intercepts the Hello message from the red vehicle located at the end of the segment, it can immediately calculate the score for the $segment_i$ using the equation

	16		30 31
VL=2			
VR=1			
DLN=1	DRN=1		
SC=/			
NT=vehicle	SFS=/	1	1

Figure 4.5: The Hello message broadcasted by the vehicle A.

4.1 as follows:

$$Score_i = \frac{TOTAL_{Vehicles}}{D_w} \cdot (L_j \times R_j) \quad (4.1)$$

D_w is the Dijkstra weight to the destination in term of distance. L_j and R_j are two flags to indicate the connectivity between two successive intersections (*i.e.*, Intersection L_j and R_j) included in the new Hello message format ($L_j=1$, it means the intersection L_j is reachable. 0 if not). $TOTAL_{Vehicles}$ is calculated based on the VL and VR information intercepted through the Hello message broadcasted by the vehicle located at the extremity of the road segment (red vehicle) based on the following equation:

$$TOTAL_{Vehicles} = (VL \text{ or } VR) + 1. \quad (4.2)$$

In another scenario (*c.f.*, Figure 4.6), when the network is sparsely connected, the vehicles located on the disconnected road segment cannot calculate their accurate number of vehicles. However, they can share the connectivity information between them and the vehicles situated at the intersection.

We assume that the source vehicle has a data packet to send (*c.f.*, Figure 4.6), it calculates the scores of all the segments around after intercepting the Hello messages broadcasted by the vehicles located at the extremity of the segments. Based on the broadcasted Hello message by the vehicle C (*c.f.*, Figure 4.7). Then the source vehicle concludes that the road segment is disconnected (*i.e.*, $R_j = 0$, we cannot reach the other side of the segment) and it cannot be selected as a transition segment.

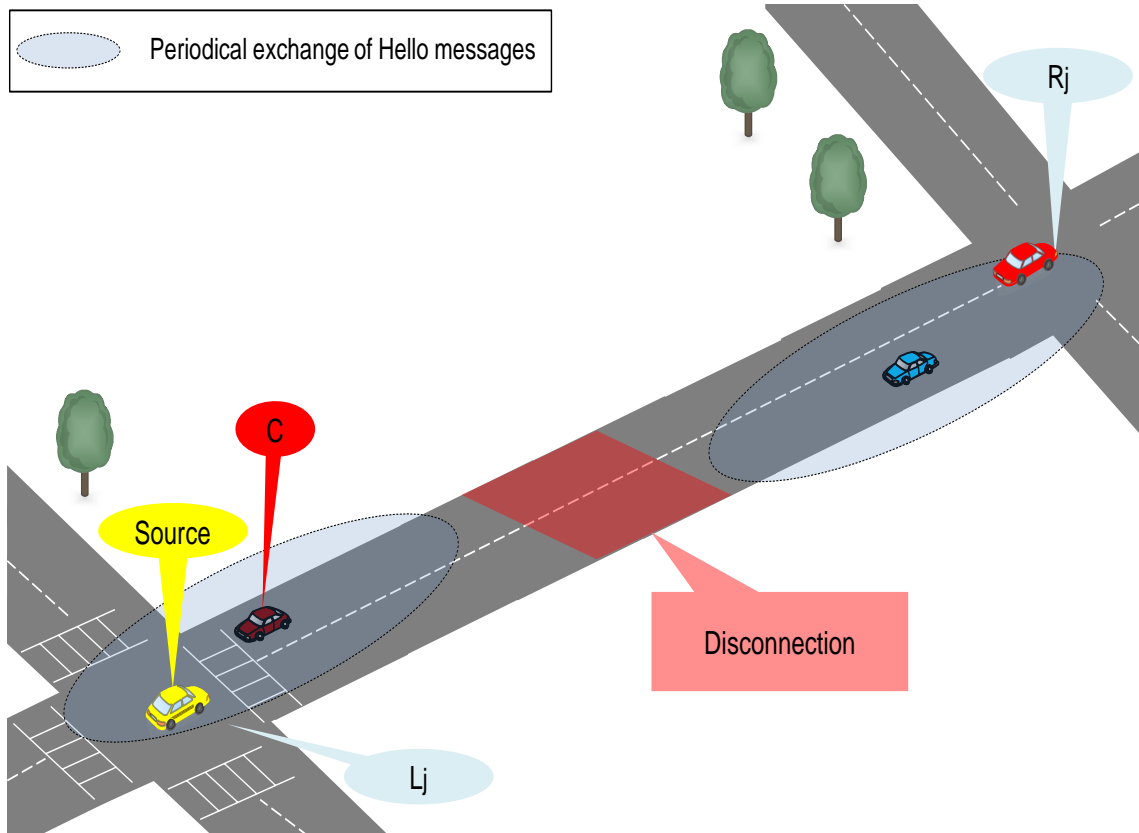

Figure 4.6: Disconnected road segment.

0		16		30	31
VL=0					
VR=0					
DLN=0			DRN=0		
SC=/ NT=vehicle					
SFS=/ NT=vehicle			1	0	

Figure 4.7: The Hello message broadcasted by the vehicle C.

4.5 Path selection

The path selection is the most complicated mechanism, due to the decision to select the most connected and the shortest path which is taken only on road intersections, because they are the only places where a routing decision is taken. Several steps are considered in the path selection as follows:

- All the vehicles located at each intersection calculate permanently a score for each segment around them.
- The segment with the best score will be selected as the convenient routing path for the destination.
- At the same time, the UAVs that overflying the area, intercept the best scores already calculated at each intersection in range through the periodical broadcasted Hello messages (*c.f.*, Figure 4.8).
- If the vehicles located at the intersections detect UAVs, other scores will be intercepted from UAVs and compared with the best score already calculated.
- The (source/forwarder) vehicle located at the intersection has to create a decision table to select the most appropriate next intersection or the UAV.
- The segment or the UAV with the highest score is selected for delivering the data packet.
- When the highest score is obtained by the UAV, in this case, the (forwarder/source) vehicle will base on the UAV to deliver the data packet to the destination vehicle (*c.f.*, Figure 4.9).
- Then, the UAV sends the packet to the forwarder vehicle situated at the selected intersection that obtained the highest score (*i.e.*, Intersection 3).
- the packet will be delivered toward the intersection 3 through the road segment where there are enough vehicles providing connectivity and it is the nearest road segment to the destination (*c.f.*, Figure 4.9).

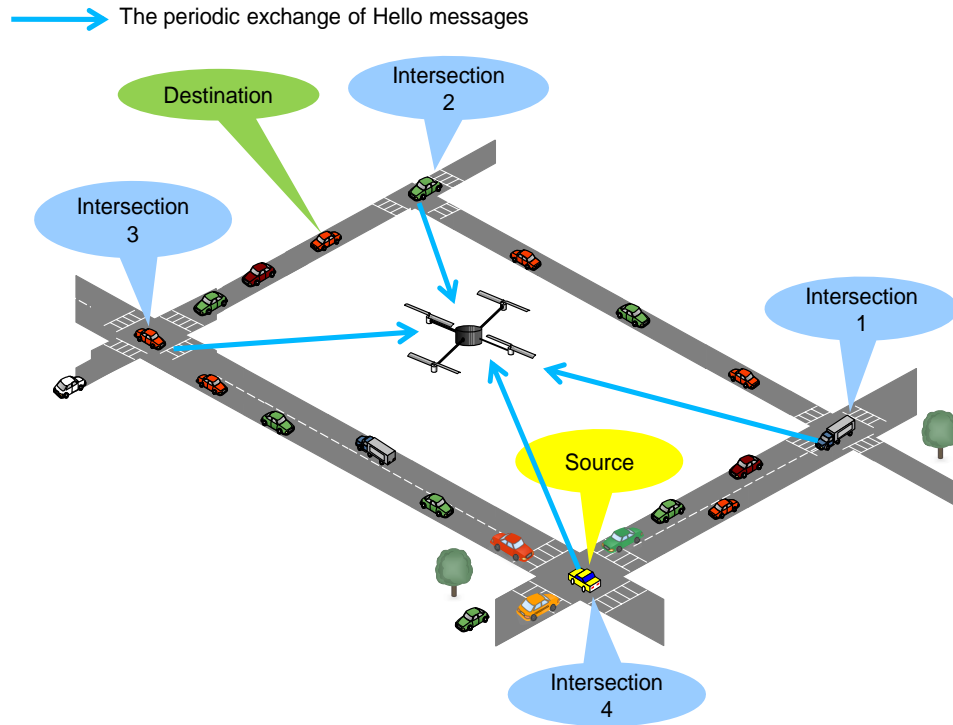

Figure 4.8: Hello message exchange.

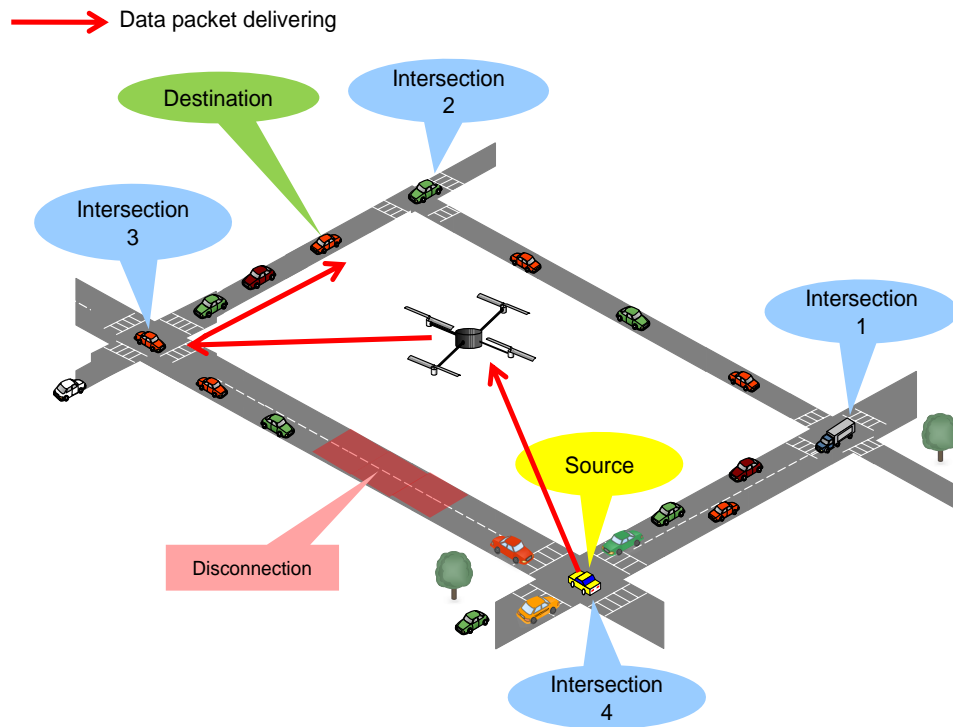

Figure 4.9: Path Selection.

The details of the CRUV’s algorithm is discribed in Algorithm 1:

Algorithm 1: CRUV Selection Strategy.

```

1 C ← The current vehicle;
2 D ← The destination vehicle;
3  $N_c$  ← The set of one hop neighbors of C;
4 J ← The current intersection;
5 if  $C = D$  then
6   | Received packet (Success);
7 else
8   | if  $D \in N_c$  then
9     | Forward (packet,D);
10  | else
11    | if  $Position(C) \in Intersection\ areas$  then
12      | foreach  $Segment_i$  do
13        |    $Score_i = \frac{TOTAL_{Vehicles_i}}{D_{wi}} \cdot (L_{ji} \times R_{ji})$ 
14        |    $J \leftarrow Max\ of\ all\ (Segment_i, Score_i);$ 
15        |   // Select the next intersection.
16      | if  $J \geq SC$  then
17        |    $SFS \leftarrow vehicle;$ 
18        |   Greedy Forwarding (packet, SFS) to the next Intersection;
19        |   // SC is the best score obtained by the UAV.
20        |   // SFS is the selected forwarding solution.
21      | else
22        |    $SFS \leftarrow UAV;$ 
23        |   Forward (packet,SFS);
24        |   Wait For Intersection or Destination();
25      |   // Wait for the intersection or Destination D

```

4.6 Performance Evaluation

In this section, we present the evaluation of the proposed approach. NS-2 (Network Simulator 2) is used to perform the simulations in order to conduct a series of experiments. Two protocols are examined, IRTIV [194] and CRUV [8] using Network Simulator 2 (NS-2). This simulation tends to demonstrate that the assistance of UAVs can improve the routing process by increasing the data delivery ratio and the delay of transmissions.

4.6.1 Simulation Model

We use VanetMobiSim [196] to generate the mobility model based on the $3 \times 3 \text{ km}^2$ area of the 9 intersections city map shown in figure 4.10. We also use MobiSim [197] to generate a Random Walk mobility model for 10 UAVs present in the network.

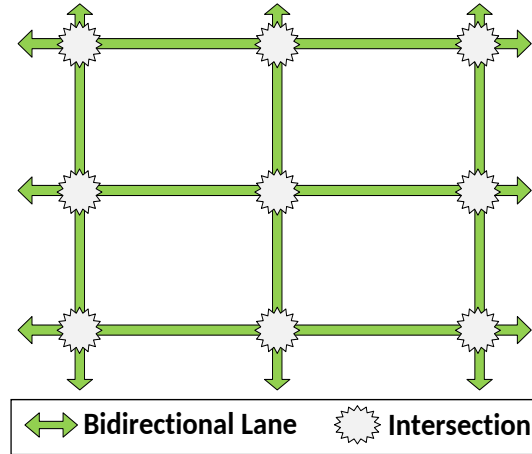

Figure 4.10: Simulation area.

Segments are bidirectional, the vehicle speed is about 0 to 50 km/h. However, the UAVs speed is about 50 to 120 km/h, which are assumed to cover each area of four road segments. Furthermore, only vehicles located at the intersections can exchange information or data packets with existing UAVs in the sky. Table 4.1 summarizes the other parameters:

Table 4.1: Simulation parameters

Parameter	Value
Simulation area	3000m \times 3000m
Number of intersection	9
Number of roads	24
Number of UAVs	10
Communication range of vehicles	\approx 300m
Communication range of UAVs	\approx 1000m
MAC Protocol	802.11DCF
Frequency Band	5.15 GHz
Number of packets senders	35
% of nodes requesting data	20%
Channel capacity	1 Mbps
Data packet size	1 KB
Number of vehicles	80-200
Vehicle speed	0-50 Km/h
UAV speed	50-120 Km/h

4.6.2 Evaluation metrics

Four metrics are considered in the evaluation process:

1. **Packet Delivery Ratio (PDR):** is defined as the percentage of packets that are successfully delivered, *i.e.*, the ratio of the total number of data packets received by the target destinations to the total number of data packets generated from the sources. The higher value of *PDR* means the better performance of the protocol. *PDR* is calculated as follows:

$$PDR = \frac{|P_r|}{|P|} \quad (4.3)$$

where $|P_r|$ is the number of packets successfully received and $|P|$ is the total number of packets generated in the system.

2. **Average End-to-End Delay (EED):** is the average time taken by data packets to reach the target destinations. It also includes the time taken by the discovery process in the case of reactive protocols, and the tail of data packets delivering. Only the data packets successfully received and generated are counted. The lower value of *EED* means the better performance of the protocol. *EED* is calculated as follows:

$$EED = \frac{\sum_{p_i \in P_r} T_a(p_i) - T_d(p_i)}{|P_r|} \quad (4.4)$$

where p_i is a received packet, $T_a(p_i)$ is the arrival time of p_i and $T_d(p_i)$ is the delivery time of the packet p_i .

3. **Average number of Hops (HOP):** can be obtained from the total number of data packets successfully delivered to the destinations divided by the total number of hops performed by all packets. As a general idea, a high number of hops means more consumed resources. The lower value of *HOP* means the better performance of the protocol. *HOP* is calculated as follows:

$$HOP = \frac{\sum_{p_i \in P_r} H(p_i)}{|P_r|} \quad (4.5)$$

where $H(p_i)$ is the number of hops traversed by packet p_i before reaching its destination.

4. **Routing overhead (OH):** is the extra routing packets to the successfully delivered packets at destinations. This metric shows the degree of saturation

of the network. The lower value of OH means the better performance of the protocol. OH is calculated as follows:

$$OH = \frac{|M|}{|P|} \quad (4.6)$$

where $M \subset P$ and $|M|$ is the total number of routing message required for finding routes for data packets.

4.6.3 Results Analysis

Our approach takes into consideration the presence of 10 UAVs in the simulation area. Also, We assume that UAVs maintain an altitude that it does not exceed $\approx 1000\text{m}$, which are considered only on the CRUV protocol. Numerous tests are done under different vehicle densities with the same parameters mentioned above. For both protocols, the vehicles and UAVs are distributed equitably on the network. In addition, we set the Hello interval to 0.1 s and we purge the table of neighbors of all nodes after 1 s of inactivity.

Figure 4.11 shows the performance in terms of the average delivery ratio for a different number of vehicles. We noticed in this figure that the proposed CRUV protocol significantly outperforms IRTIV. The main reason is, our protocol CRUV always finds the best intersection to forward the data packet to the destination because it selects the appropriate intersection by comparing the scores obtained at the current intersection and the intercepted ones from the UAVs. Consequently, CRUV can select the UAV as a forwarder instead of vehicles when the network is sparsely connected. However, IRTIV takes into account only the best score calculated at the current intersection.

In figure 4.12, we compare the performance of the two protocols in terms of the average delay. We can distinguish that CRUV has a lower delay compared with IRTIV. This is because CRUV has more chance to reach the destination than IRTIV because sometimes it chooses UAV, which reduces considerably the distance traveled by the data packet to the destination. However, IRTIV combines Greedy Forwarding and the Dijkstra weight to select the shortest path, which take more delay to select at each moment the next forwarder.

The average number of hops is the ratio between the number of data packets delivered successfully to their destinations and the total number of hops carried out by all packets. Lower average number of hops, more the performance is the protocol. In figure 4.13, The number of hops is improved when the number of vehicles increases for our approach. When the density of vehicles is low, the number of hops increases because the vehicles located at the current intersection do not find a connected path due to the problem of partition, which often let them trying to find the present UAVs in range to forward data packets to them, which increases the number of hops.

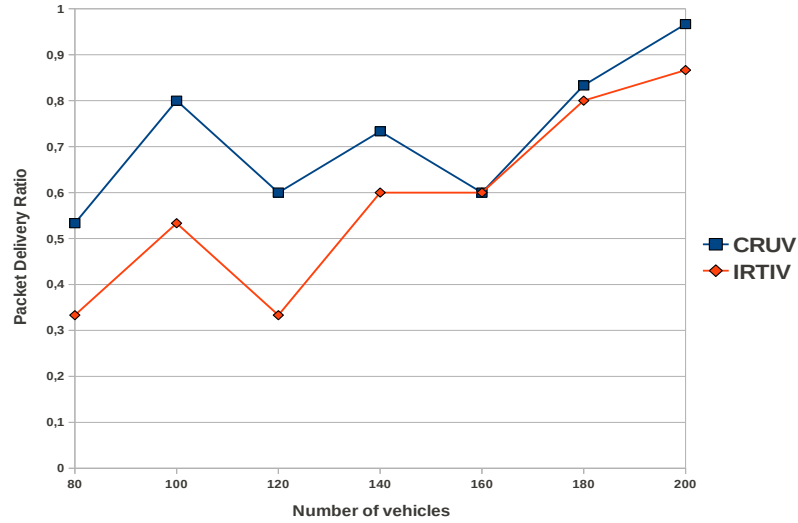

Figure 4.11: Packets delivery ratio vs. vehicle density

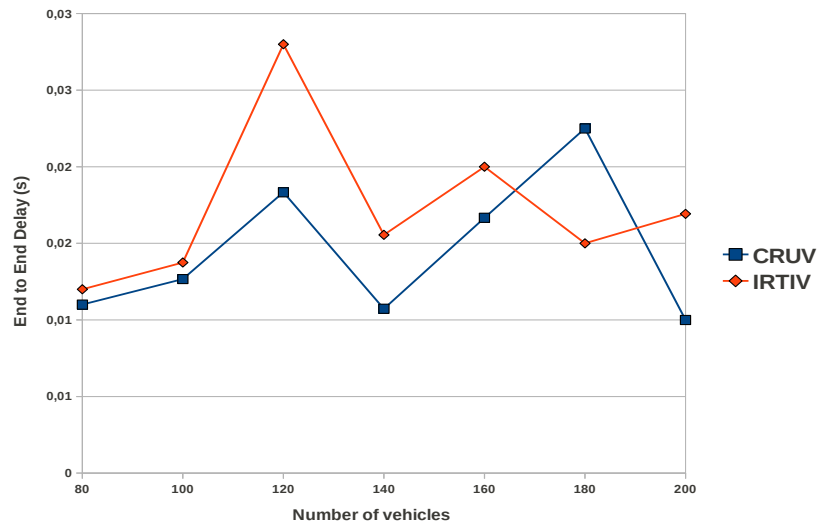

Figure 4.12: End-to-End delay vs. vehicle density

However, when the number of vehicles increases, the selection of the intersection is always successful and generally promotes UAVs than the next intersections which decreases significantly the number of hops. The number of hops decreases when the number of vehicles decreases for IRTIV because the networks become more sparse and the protocol uses the store-carry and forward technique to overcome the problem of disconnection reducing the number of hops of the data packets.

As shown in Figure 4.14, the outcomes are clear, we distinguish that CRUV generates more overhead than IRTIV. This is explained by the additional periodical exchange of Hello packets between existing UAVs with vehicles located at the intersections. Indeed, as the number of vehicles increases, the vehicles located at inter-

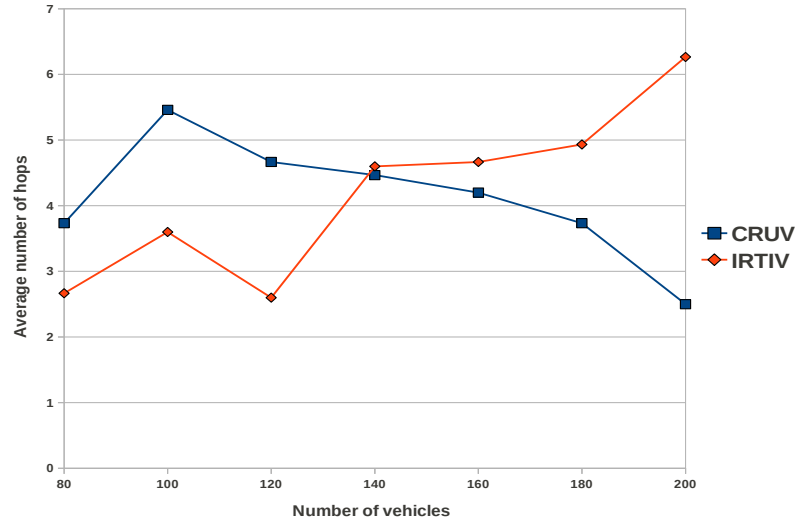

Figure 4.13: Average number of hops vs. vehicle density

sections increases, the exchange of Hello packets increases between vehicles, and the exchange of Hello packets with UAVs also increases. However, it is not the case of IRTIV, which generates less overhead in all vehicle densities compared with CRUV. This is mainly due to the fact that there are no UAVs in the sky, and consequently, no exchange of Hello packets with them. In addition, the exchange of Hello is only distinguished between vehicles located on the road segments and not at the intersections, which explains the slight increase in the overhead. The overhead in both protocols is increased progressively with the increase of the vehicles' number.

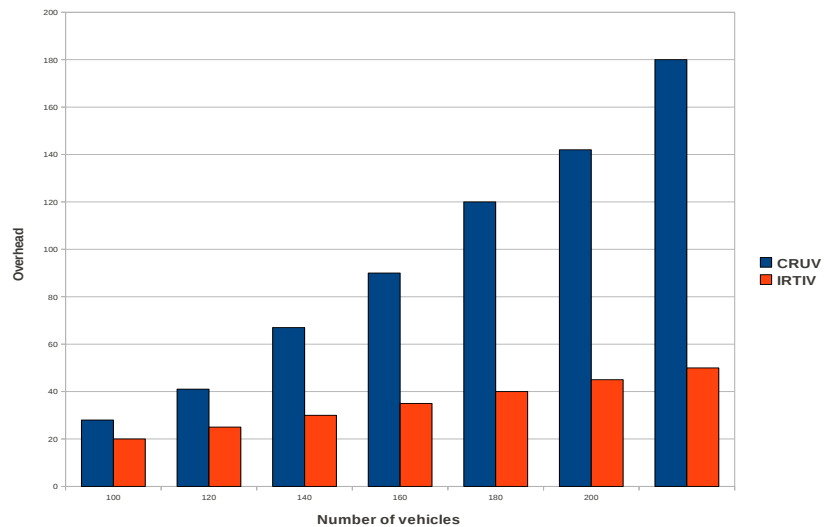

Figure 4.14: Overhead vs. vehicle density

4.7 Conclusion

In this *chapter*, we proposed a novel routing protocol specific for VANETs called CRUV (Connectivity-based Traffic Density Aware Routing using UAVs for VANETs). It can find at each moment the shortest stable connected path in order to forward packets more efficiently to their destinations by combining the real-time traffic density based on the periodic exchange of Hello messages, and the Dijkstra algorithm to determine the shortest path towards the destination. UAVs have been used to make the routing strategy more efficient and reliable in order to avoid obstacles that have a negative impact in delivering packets. As future work, we intend to bring new features to our approach in order to simulate it and to compare it with other protocols in the same context.

Several limitations are distinguished in CRUV, which can degrade the performance of the routing process. Indeed, the UAVs are not fully exploited by CRUV since they are used only for delivering data packets when the road segments on the ground are partitioned or to explore other connected road segments somewhere else on the network. Furthermore, CRUV takes into account only the number of vehicles and the connectivity of the road segments as selection criteria, but neglects the real distribution of vehicles on the selected road segment, which is very important to measure the degree of connectivity. Two recovery strategies are used, (i) the store-carry and forward technique, which causes an important delay of data delivery and (ii) the data delivery through UAVs in the case when the network is poorly dense or partitioned. Consequently, many issues have to be addressed in CRUV by increasing the number of recovery strategies and fully exploiting UAVs in the sky. In addition, the real distribution of vehicles on the ground has to be considered in order to measure accurately the connectivity factor on the road segments.

In the next *chapter*, our second UAV-assisted routing protocol is introduced which addresses all distinguished drawbacks of CRUV. This protocol consists of two routing components called UVAR-S and UVAR-G, which operate in the sky and on the ground respectively. UVAR-S fully exploits UAVs in the sky to deliver data packets in the sky and avoid disconnections and obstructions on the ground. UVAR-G takes into account the real distribution of vehicles in the road segment selection using existing UAVs in the sky. These two routing components can be used in parallel to accomplish the same objective which is delivering data packets to their target destinations reliably and efficiently.

Chapter 5

UVAR–UAV-Assisted VANET Routing Protocol

Contents

5.1	Introduction	86
5.2	Assumptions	87
5.3	System model	88
5.4	UVAR-G	89
5.4.1	Traffic density estimation	89
5.4.2	Connectivity detection	91
5.4.3	Segment selection	93
5.5	UVAR-S	97
5.5.1	Discovery process	98
5.5.2	Routing decision process	99
5.5.3	Recovery process	101
5.6	Performance evaluations	103
5.7	Results analysis	104
5.7.1	Average delivery ratio	105
5.7.2	Average delay	107
5.7.3	Overhead	109
5.7.4	Average number of hops	109
5.8	Conclusion	113

5.1 Introduction

In this *chapter*, we introduce UVAR (UAV-Assisted VANET Routing Protocol), which is a novel routing protocol collaborating with existing UAVs in the sky in order to have a global vision of the connected segments and improve the routing [9]. To avoid the limitations in our previous works [8, 159], UVAR protocol takes into account the real distribution of vehicles in the selected road segments, which not only provides accurate calculations of vehicle connectivity, but also overcomes the present obstacles distorting the calculation. In UVAR, UAVs are also used for the connectivity calculation with the help of their global vision of the overflowed road segments. Despite the use of the principle of forwarding data packets on the ground, UVAR fully exploits UAVs since the problem of obstacles no longer arises in the sky. Table 5.1 clarifies the limitations of previous works compared with our current work.

Table 5.1: Comparative study between our works.

Criteria	ETAR [159]	CRUV [8]	Current work [9]
Real distribution of vehicles	×	×	√
Obstacles avoidance	×	√	√
Exploitation of UAVs	<i>None</i>	<i>Partially</i>	<i>Fully</i>
Maintenance methods	<i>One</i>	<i>Two</i>	<i>Many</i>
Average delay	<i>High</i>	<i>High</i>	<i>Low</i>
Average delivery ratio	<i>Low</i>	<i>Low</i>	<i>High</i>

The full exploitation of UAVs can be done in several ways, such as the perpetual calculation of the connectivity degrees on road segments, delivering data packets directly to their target destination and the most of the time as nodes used for maintenance when the network becomes sparsely connected on the ground. In the previous works [8, 159], we use a maximum of two kinds of maintenance technique for the broken paths which are carry-and-forward and the UAVs when the network is sparsely connected. However, in our current work, more maintenance techniques are used both on the ground and in the sky, beside those used in our previous works. In general, there are two possible ways for data delivery, which should be determined according to the score calculated for each method. The data delivery is completely improved using this hybrid communication between vehicles and UAVs, which helps to considerably decrease the packet losses and delivery delay.

UVAR is composed of two routing components which can be used in parallel, each illustrating a routing strategy of data packets: (i) UVAR-G forwards data packets on the ground through connected vehicles, and (ii) UVAR-S forwards data packets in the sky through connected UAVs. Before proceeding, we first present the different assumptions which are taken into account by UVAR and its architecture model, and then we describe the functioning details of the UVAR’s components.

5.2 Assumptions

The UVAR protocol assumes that each vehicle or UAV is equipped with a GPS and digital map to obtain their current geographical positions and locate the neighboring intersections respectively. Nodes (Vehicles/UAVs) in UVAR have no energy restrictions since they are equipped with batteries which can be recharged from energy resources (*e.g.*, fuel, solar energy, *etc.*).

Most of the urban applications that use UAVs like small Quad-Copters do not fly at high altitudes, such as in [198, 199]. Therefore, in this *chapter*, we assume that UAVs have a low and constant altitude during the flight in order to be able to communicate with vehicles on the ground. IEEE 802.11p wireless interfaces with a large transmission range (*i.e.*, up to 1000 m [200, 201]) are assumed to be used by UAVs. In addition, we assume that the selected urban area has a sufficient number of UAVs so that at each moment, each area of four road segments is covered by at least one UAV (*c.f.*, Figure 5.1).

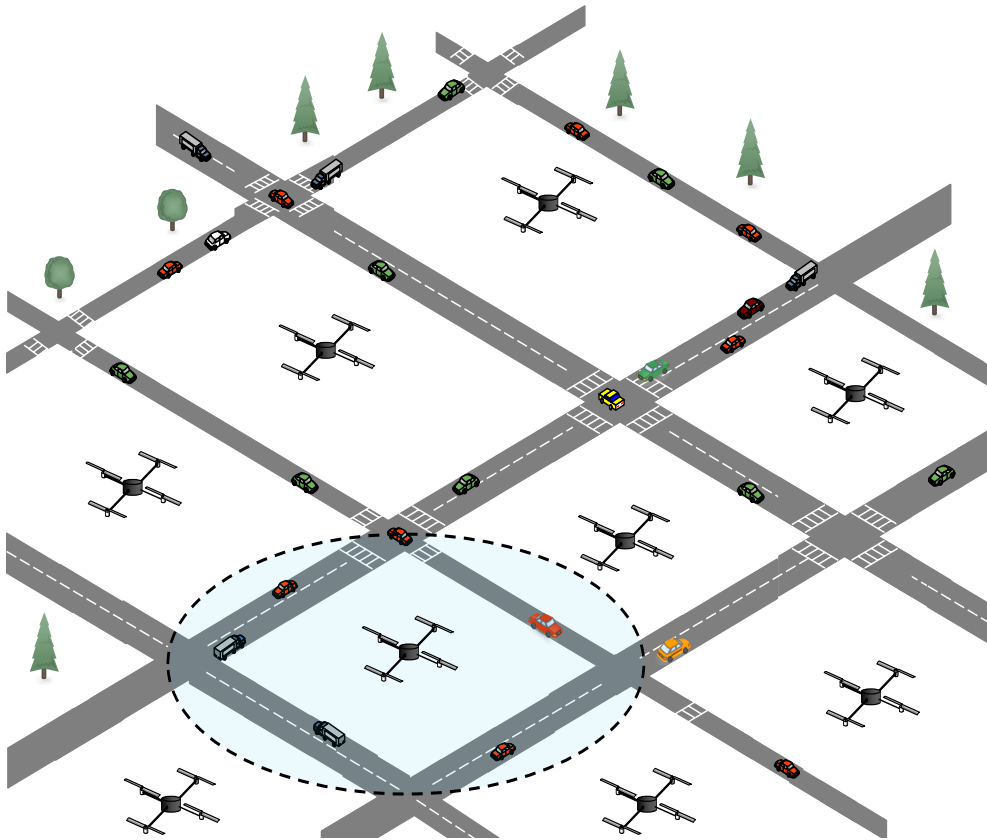

Figure 5.1: Overview of the assumed scenario.

5.3 System model

As shown in Figure 5.2, the system is composed of a set of vehicles and UAVs fairly distributed on the network. In our hybrid communication system, we adopt the IEEE 802.11p MAC protocol for both inter-vehicular communication and UAV-to-Vehicle communication, since this MAC protocol is expected to be widely used by the industry and the most suitable for vehicular scenarios [202]. In addition, a line of sight is supposed to be indispensable for wireless communications involving a hybrid communication between vehicles and UAVs, since the UAVs are located in the middle of a four road segments area in which a radio signal can be distorted by existing obstacles (*e.g.*, buildings, *etc.*).

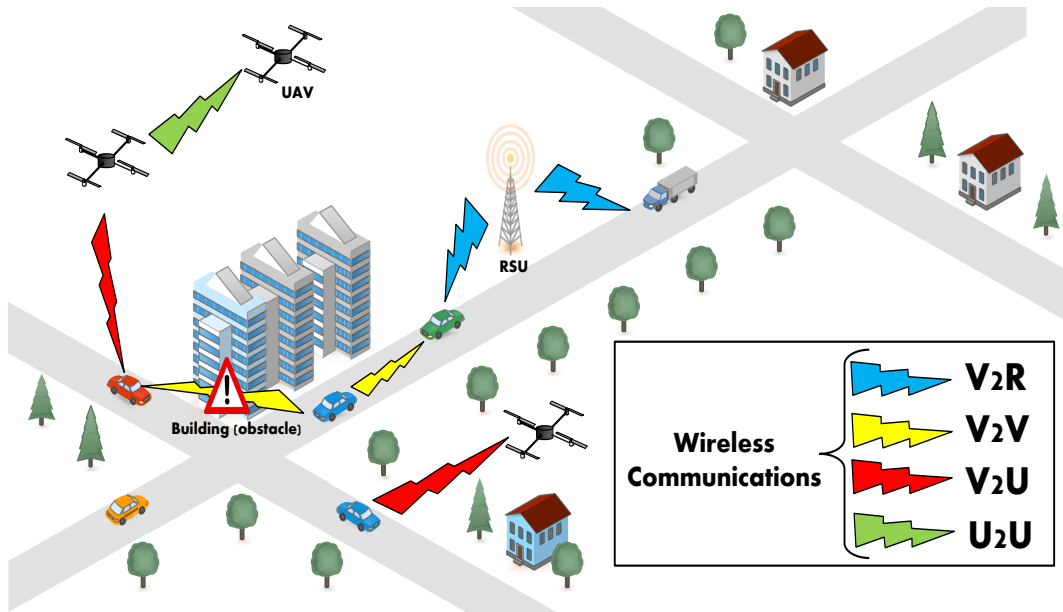

Figure 5.2: Communication architecture of UVAR.

Four kinds of wireless communications are used in our system as follows:

1. **Vehicle-to-Vehicle (V2V)**: Vehicles are able to communicate with other vehicles in their communication range and line of sight. However, the wireless communication cannot be carried out between vehicles which are on different streets not opposite from each other due to the presence of obstacles. In this case, UAVs can be exploited as forwarding nodes to transmit data packets in order to avoid existing obstacles. In addition, all vehicles can store and carry the data packets for a certain moment until they reach next forwarders.
2. **Vehicle-to-Roadside unit (V2R)**: Roadside units (RSUs) can be deployed in different places such as intersections, petrol stations, interchanges, *etc.* RSUs provide wireless interfaces to V2R communication within their range.

The communications between RSUs and vehicles are established when some applications need to be run such as Internet access, service discovery and *etc.*

3. **Vehicle-to-UAV (V2U)**: UAVs are small mobile drones, which can fly autonomously without human interaction. The significant characteristic of UAVs is that their movements can be controlled using algorithms, which makes small commercial Quad-copters to be the most suitable choice. Vehicles can communicate directly with UAVs hovering the area and vice versa. The communication range of the UAVs is assumed to be sufficiently large enough for air-to-ground communications (V2U), so they will not be affected by the obstacles (*e.g.*, buildings, *etc.*).

We note that we treat the range of all the vehicles and UAVs as the same when the communications need to be established between them. In addition, UAVs are also able to deliver data packet when they quickly detect the target destination somewhere in another road segment or intersection in the case when it is not possible to deliver data packets on the ground due to the unavailability of connected road segments.

4. **UAV-to-UAV (U2U)**: The UAVs can communicate with each other.

5.4 UVAR-G

The first component of our routing protocol UVAR, namely, UVAR-G, is conceived for delivering data packets on the ground exclusively through vehicles to the target destination, where its geographical position is supposed to be known using a location service such as GLS (Grid Location Service) [176]. UVAR-G is a routing component based on the gradual selection of next intersections by taking into consideration the real time traffic density variation on roads and their connectivity through which data packets are delivered to their respective destinations. UVAR-G can be run in three steps: (i) First, the information on traffic density is obtained through a centralized mechanism which is executed only on UAVs, then (ii) the detection of connectivity is carried out based on the collected information from UAVs, and finally (iii) the selection of the appropriate segment (next intersection) will take place.

5.4.1 Traffic density estimation

To estimate the traffic density on a specified road segment, we have fractionated each road segment into fixed zones of an equal size similar to the communication range of vehicles (≈ 300 meters). Each area of four road segments is covered by a UAV which collects the periodical exchange of Hello packets between vehicles on each

segment. Indeed, each UAV creates and maintains a *table of density* for every road segment. Then, after intercepting all the required broadcasted Hello packets, the total number of vehicles is extracted from the table. The example of Figure 5.3 represents the traffic density calculation process, where the UAV collects the broadcasted Hello packets from vehicles located on a road segment divided into five fixed areas.

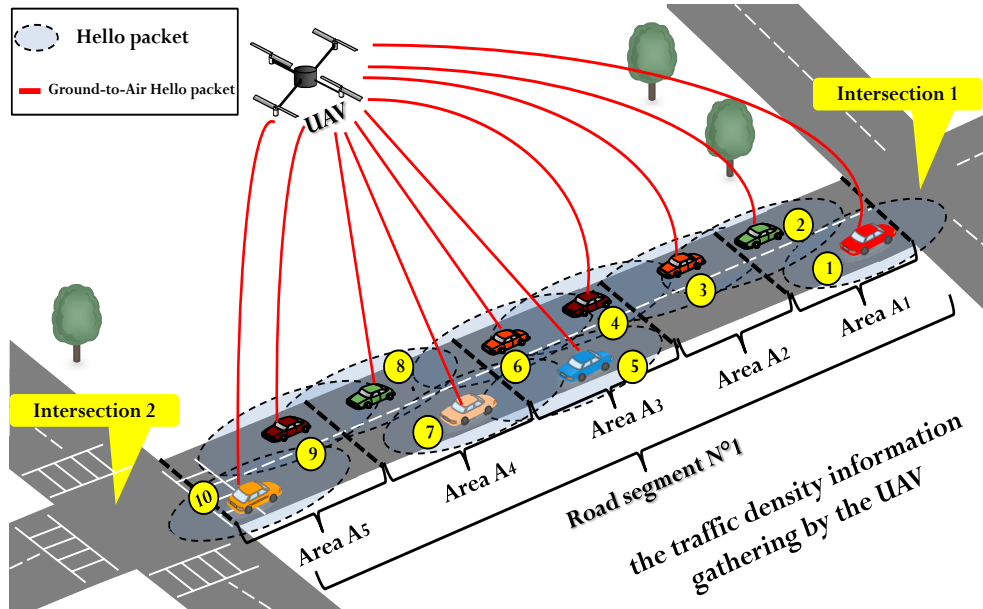

Figure 5.3: Traffic density estimation.

The *table of density* (see TABLE 5.2) contains the exact number of vehicles and their geographical coordinates per area in the segment number 1 (*c.f.*, Figure 5.3).

Table 5.2: Table of density of the segment 1.

Segment 1			
Area	Number of vehicles	Vehicles	Coordinates
A_1	2	v_1	(10.00, 5.50)
		v_2	(190.00, 5.00)
A_2	1	v_3	(320.00, 5.00)
		v_4	(370.00, 5.50)
A_3	3	v_5	(410.00, 5.50)
		v_6	(510.00, 5.00)
A_4	2	v_7	(680.00, 5.50)
		v_8	(790.00, 5.00)
A_5	2	v_9	(800.00, 5.00)
		v_{10}	(980.00, 5.50)

The total number of vehicles in segment S is given by:

$$V(S) = \sum_{i=1}^{|S|} V(A_i) \quad (5.1)$$

Where $|S|$ is the total number of fixed areas within a specific road segment S (e.g., in Figure 5.3, the number of areas in segment 1 is equal to 5). $V(A_i)$ is the number of vehicles in the area A_i .

5.4.2 Connectivity detection

The connectivity is detected using a simple technique of position's calculation based on the *table of density* (see TABLE 5.3) of the segment number 1 (c.f., Figure 5.3), which is sorted by the geographic coordinates of vehicles according to the corresponding segment. Furthermore, the X and Y coordinates of the two successive intersections are inserted in the sorted table.

Table 5.3: Sorted table of density.

Segment number 1		
Node	Vehicles/Intersection	(x, y)
n_0	i_1	(0.00, 5.00)
n_1	v_1	(10.00, 5.50)
n_2	v_2	(190.00, 5.00)
n_3	v_3	(320.00, 5.00)
n_4	v_4	(370.00, 5.00)
n_5	v_5	(410.00, 5.50)
n_6	v_6	(510.00, 5.00)
n_7	v_7	(680.00, 5.50)
n_8	v_8	(790.00, 5.00)
n_9	v_9	(800.00, 5.00)
n_{10}	v_{10}	(980.00, 5.50)
n_{11}	i_2	(1000.00, 5.00)

Based on the sorted *table of density*, the UAV can immediately deduct if the segment number 1 is connected or not, according to the degree of connectivity δ . To compute δ , few definitions are needed. Two vehicles v_i and v_j are said to be *directly connected*, that is $dconn(v_i, v_j) = True$, if $dist(v_i, v_j) \leq R_V$, where R_V is the transmission range of the vehicles. Two vehicles v_i and v_j are said to be connected, that is $conn(v_i, v_j) = True$, if either $dconn(v_i, v_j) = True$, or there exists a vehicle v_k such that $dconn(v_i, v_k) = True$ and $conn(v_k, v_j) = True$. A road segment S

is said to be *connected* at a given time, that is $conn(S) = True$, if the two ends of the segment are connected. For the two intersections defining a road segment to be said connected, we assume that any hypothetical vehicle at one intersection should be able to connect with a hypothetical vehicle at the other intersection of the segment. Therefore, a segment is connected when direct or indirect connectivity is made possible between its two ends through the vehicles running on that segment. Since we extended the definition of connectivity to the intersections of a segment, the definition of *dist* should be applied similarly to intersections as well. Therefore, we define N as the sorted set of vehicles within a segment based on their geographical position, plus the two intersections. That is, $N = S \cup \{i_1, i_2 | i_1, i_2 \in I\}$ where I is the set of road intersections and i_1 and i_2 are the two intersections defining segment S .

Given two nodes n_i and n_j from the set of vehicles in segment S or its intersections, the function $dist(n_i, n_j)$ is performed such as that the degree of connectivity results in an integer number. That is, assuming that (x_i, y_i) are the coordinates of the node n_i and (x_j, y_j) are the coordinates of n_j , the function $dist$ is defined as follows:

$$dist(n_i, n_j) = \begin{cases} R_v, & \text{if } x_i = x_j \text{ and } y_i = y_j \\ \sqrt{(x_i - x_j)^2 + (y_i - y_j)^2}, & \text{otherwise} \end{cases} \quad (5.2)$$

δ is calculated by the following formula:

$$\delta = \prod_{i=0}^{|N|-1} \left\lfloor \frac{R_v}{dist(n_i, n_{i+1})} \right\rfloor \text{ where } n_i, n_{i+1} \in N \text{ and are successive nodes} \quad (5.3)$$

When $\delta > 0$, it means that the segment is connected and it should be compared with other connected segments in order to choose the most connected one which has the highest δ . However, since we take the floor of $\left\lfloor \frac{R_v}{dist(n_i, n_{i+1})} \right\rfloor$, when $\delta=0$, it means the segment is disconnected and cannot be selected to transmit the data packets.

Table 5.4: Sorted table of density (scenario 2).

Segment number 1		
Node	Vehicles/Intersection	(x, y)
n_0	i_1	(0.00, 5.00)
n_1	v_1	(10.00, 5.50)
n_2	v_2	(190.00, 5.00)
n_3	v_3	(320.00, 5.00)
n_9	v_9	(800.00, 5.00)
n_{11}	i_2	(1000.00, 5.00)

In another scenario, when segment 1 is sparsely connected (*c.f.*, Figure 5.4), the UAV collects the broadcasted Hello packets between vehicles in order to fill the *table of density* (see TABLE 5.4). The connectivity is calculated using the formula (5.3). The UAV deducts immediately that segment 1 is disconnected ($\delta=0$) and it cannot be selected as transition segment.

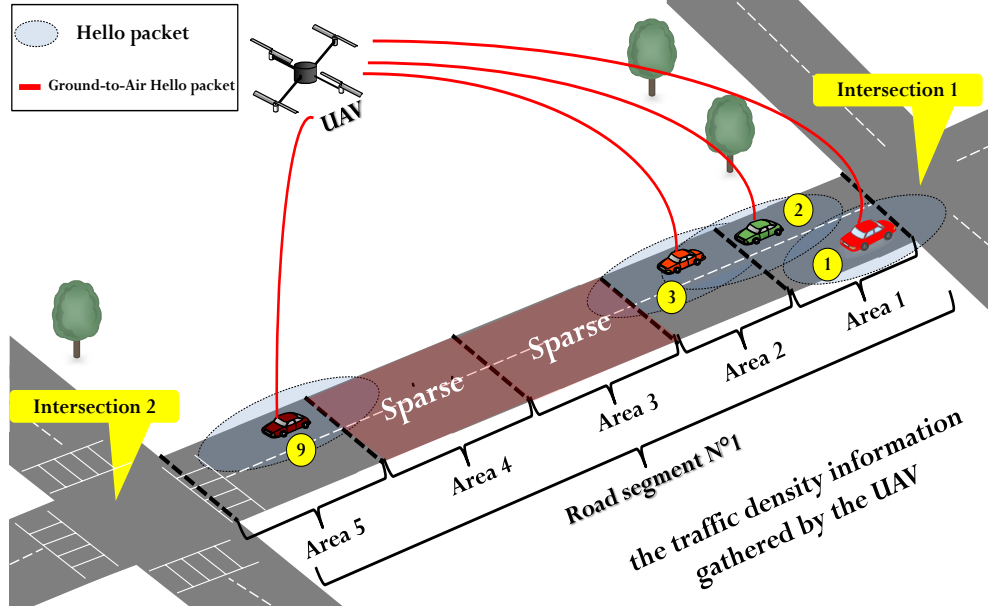

Figure 5.4: Sparsely connected segment.

The disconnected segments will be ignored and UVAR-G tries to find another alternative solution as follows:(i) first, it tries to find another connected segment, (ii) second, in the case when there is no connected segment, UVAR-G is switched to UVAR-S which is based exclusively on UAVs to deliver data packets in the sky, (iii) finally, if UVAR-S fails to deliver the data packets to the target destination, the current vehicle uses the carry and forward technique as a recovery strategy.

5.4.3 Segment selection

UVAR-G adopts a technique of scoring by attributing a score to each road segment. The score is calculated by combining the degree of connectivity, the awareness of the real distribution of the traffic density and the shortest distance between the current node and the target destination. Based on the collected table of density (see TABLE 5.2), first, the corresponding UAV calculates the real distribution of the traffic variation on the road segment (*c.f.*, Figure 5.3) by calculating different metrics such as the average number of vehicles (μ) per area and the standard deviation of the

area densities (σ) as follows:

$$\mu = \frac{1}{|S|} \times \sum_{i=1}^{|S|} V(A_i) \quad (5.4)$$

Second, the standard deviation indicates how the densities of vehicles are distributed around the average.

$$\sigma = \sqrt{\frac{1}{|S|} \times \sum_{i=1}^{|S|} (V(A_i) - \mu)^2} \quad (5.5)$$

Generally, a large standard deviation indicates that the vehicles are more widely dispersed, while a small standard deviation denotes that the vehicles are not widely dispersed around the average and consequently, vehicles are not fairly distributed in the corresponding path, which can cause disconnection at any time.

A multi-criteria score proper for each road segment candidate (*i.e.*, next intersection candidate) can be calculated based on the previously calculated parameters. The score favors the road segment, which has the highest degree of connectivity and the shortest distance to the target destination. This score is called $Score_G$, which is calculated for the UVAR-G protocol as follows:

$$Score_G = \delta \times \left(\frac{R_V}{(1 + \sigma) \times D_w} \right) \quad (5.6)$$

D_w is the length of the shortest road segments between the current node and the target destination.

As we can see, equation (5.6) is based on three factors:

- The first factor (δ) is to measure the connectedness degree of each road segment candidate, which can be considered as a favoring factor.
- The second factor $\left(\frac{1}{(1+\sigma)}\right)$ is to measure the regularity and stability of a road segment, which is calculated based on the dispersion degree (σ), which provides an idea about the distribution of vehicles on a given road segment. It is considered as a disadvantageous factor.
- The third factor $\left(\frac{R_V}{D_w}\right)$ is a ratio between the transmission range of vehicles and the shortest distance to the target destination, which is considered as a disadvantageous factor as well.

By multiplying these three factors, we obtain a proper value for each road segment. The bigger is $Score_G$, the more regulated and stable is the road segment and vice

versa.

To understand more the D_w calculation, we consider the pair of vehicles (current/destination). D_w is the shortest distance between the current node and the target destination. By applying Dijkstra’s Algorithm, the UAVs use the current geographic locations of the current node (*i.e.*, the requesting node) and that of the target destination which is supposed to be known using a location service such as GLS (Grid Location Service) [176]. D_w is automatically calculated which represents the shortest distance between the source node S and the destination node D along the road segments and through the road intersections.

To illustrate the calculation of D_w , let us consider Figure 5.5 which represents a scenario of path selection carried out by the source vehicle at *intersection 0*. Based on our assumption, each node in the network is supposed to have the whole map, its current position and that of the destination node [176]. Two routing paths are available: *Path 1* through *road segment 1* and *intersection 3*, and *Path 2* through *road segment 2*, *intersection 1* and *2*. The existing UAV calculates the real distribution of vehicles in each road segment and applies Dijkstra’s algorithm to compute D_w . We have $D_w = 1 \text{ km}$ for *road segment 1* and $D_w = 4,5 \text{ km}$ for *road segment 2*. After this calculation, a $Score_G$ is calculated for each road segment which is then broadcasted to the source vehicle. By comparing the two scores, the source vehicle favors the routing path with the highest and regulated density in which a short distance is a plus.

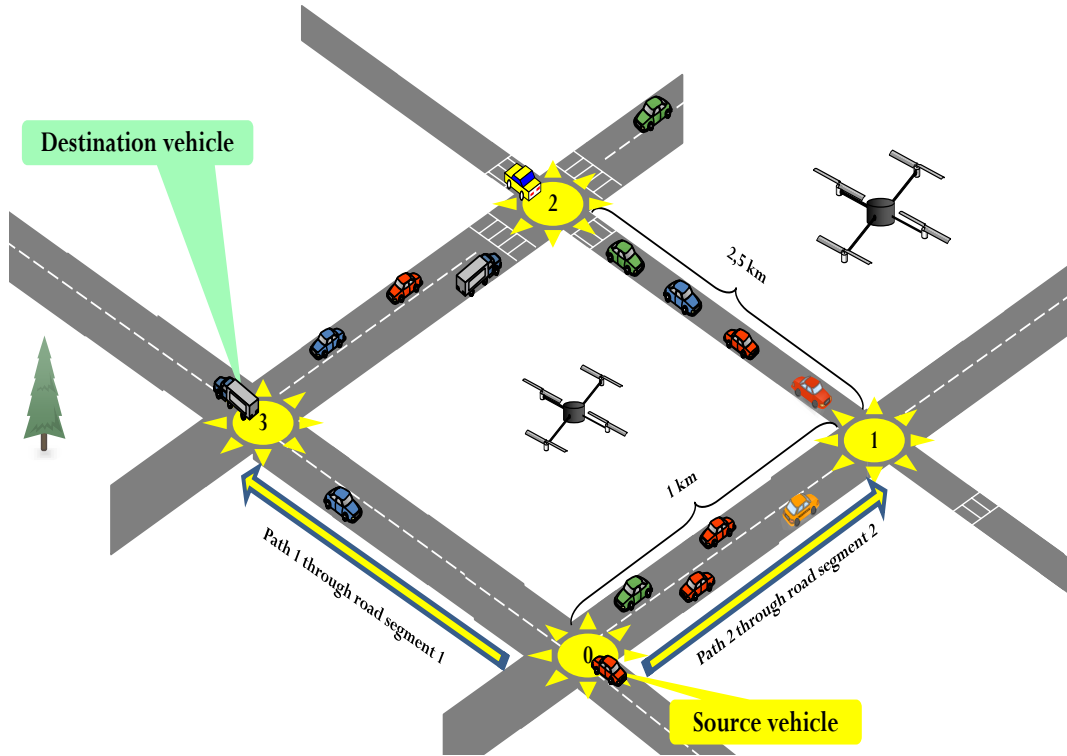

Figure 5.5: D_w calculation scenario.

Pseudo code of UVAR-G is shown in Algorithm 2:

Algorithm 2: UVAR-G

```
1 C ← The current vehicle;
2 D ← The destination vehicle;
3 I ← The next intersection;
4  $N_c$  ← The set of one-hop neighbors of C;
5 if  $C == D$  then
6   Received packet(Success);
7   //If I am the target destination.
8 else
9   if  $D \in N_c$  then
10    Forward(packet,D);
11    //If the target destination is a neighbor of the current
    vehicle, the data packet is forwarded directly.
12  else
13    if  $Position(C) \in Intersection\ zones$  then
14      foreach  $Segment_i$  do
15        Collect from UAVs( $Score_G$ );
16        Select(I, $Score_G$ , $Dijkstra_i$ );
17         $I \leftarrow Max$  of all ( $Segment_i$ );
18        // Select the next intersection of the shortest
        connected segment.
19    else
20      if  $\exists vehicle \in N_c$  then
21        Greedy Forwarding (packet,C,I);
22      else
23        Carry and forward (packet,C,I);
24        Wait For neighbors();
```

The calculated $Score_G$ of each covered segment is shared with vehicles located at the intersection through the periodically broadcasted Hello packets. The UAVs update the $Score_G$ of each road segment periodically and perpetually, which can provide a near-accurate distribution of vehicles on segments at each time unit. Formula (5.6) is an empirical equation to compute $Score_G$, which takes into account those three parameters impacting the quality of the routing path. In our numerical simulations, which will be presented in Section 5.6, $Score_G$ is shown to be a good integrated criteria for the path selection. The selection process is carried out at the intersection in the current (source/forwarder) vehicle because it is the only place where a routing decision is taken. The current vehicle compares intercepted $Score_G$ of all the segments around. The segment with the highest score is selected for delivering the data packet to the destination vehicle. Once the segment is selected, the greedy forwarding technique is used as a forwarding mechanism to deliver the data packet before arriving at the next intersection. However, due to the high mobility of vehicles, disconnections can

occur, in this case, the forwarder vehicle continues to carry the packet until the next intersection or delivers it to the vehicle moving towards the next intersection.

5.5 UVAR-S

UVAR-S is the second component of our routing protocol which can be run at the same time with UVAR-G. UVAR-S is a reactive routing protocol that establishes paths on demand, by using an original discovery process in the sky in order to find the most connected sequences of UAVs to the target destination. The key idea behind this approach is to select the closest UAVs of each other so as to guarantee a long time of connectivity. In certain cases, the selected sequence of UAVs between a source and destination can be quickly broken due to the high mobility of UAVs. Intelligent path maintenance is used to find an alternative path and avoid initializing a new discovery process. Three steps are required to operate UVAR-S: (i) First, a discovery process is initialized on demand when a source has data packets to send, then (ii) several paths (sequence of UAVs) are intercepted by the destination in which a routing decision has to be taken to select the most connected one, and to send the selected path back to the source through a RREP packet. Finally, (iii) the source node starts to send data packets via the selected path.

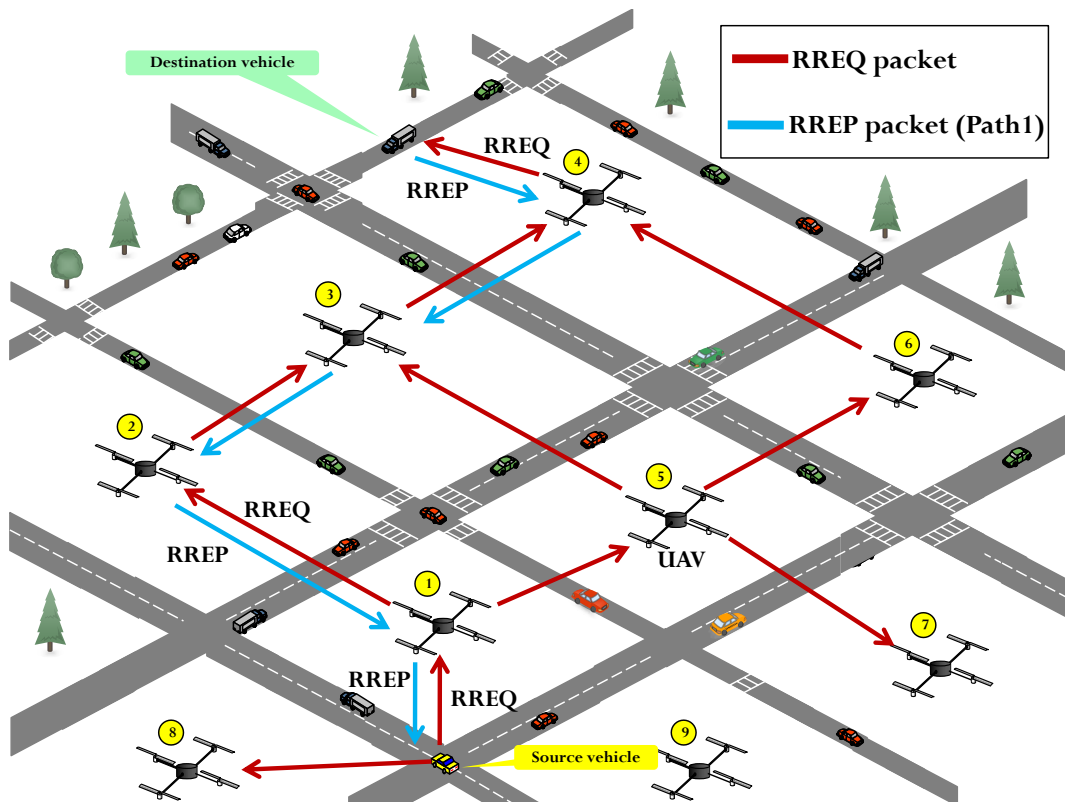

Figure 5.6: Discovery process of UVAR-S.

5.5.1 Discovery process

UVAR-S is conceived based on the reactive broadcasting. When the source vehicle S wants to establish a communication with destination vehicle D , S initiates the discovery process by flooding a RREQ in order to discover both all the sequences of UAVs toward D and obtain its geographical location since UVAR-S does not assume any use of a location service (see Figure 5.6). These discovered sequences of UAVs (The existing direct links between UAVs) are cached in each intermediate node and used to send data packets correctly. Furthermore, they are also used in the maintenance process.

The RREQ packet is handled by all nodes as shown in Algorithm 3:

Algorithm 3: UVAR-S (RREQ handling)

```

1  $C \leftarrow$  The current node (vehicle/UAV);
2  $List_{RREQID} \leftarrow$  List of treated RREQs;
3 if (Source (RREQ) =  $C$ ) OR
4 ( $RREQID \in List_{RREQID}(C)$ ) then
5   Drop (RREQ);
6   // Be the source vehicle of this RREQ or I already received
   this RREQ, it will be ignored.
7 else
8   if Destination (RREQ) =  $C$  then
9     Routing Selection Process ();
10    // If I am the target destination, I will make a routing
    decision.
11  else
12    Record ( $RREQID, List_{RREQID}(C)$ );
13    Add ( $UAV_{ID}, traversed\ UAVs(RREQ)$ );
14    Rebroadcast (RREQ);
15    // A new RREQ will be recorded and broadcasted.

```

- **The route request (RREQ) packet format:** The RREQ packet consists of several fields (*c.f.*, Figure 5.7). The $RREQID$ field identifies the initiated discovery path process to which the RREQ packet belongs. The lifetime field determines the expiration time of the RREQ packet, which is an important parameter to avoid flooding of the entire network. The identifier fields of source and destination. UAV field is a succession of transited UAVs (ID and position) by the RREQ packet until it reaches the target destination.
- **The RREQ flooding:** To avoid the impact of the broadcast storm, a $RREQID$ field is included in the RREQ packet. When a UAV receives a RREQ packet

	0	16	31
Source ID			
Destination ID			
RREQ ID		Life time	
UAV ID (0s when source)			
UAV Latitude			
UAV Longitude			
UAV Altitude			

Figure 5.7: The Route Request (RREQ) packet format.

which has the same $RREQ_{ID}$ with a previously received one, it will be ignored. Otherwise, the $RREQ_{ID}$ of the received RREQ packet will be cached in the $List_RREQ_{ID}$ of this UAV. Then, the RREQ packet will be broadcasted and the same process is carried out by all intermediate nodes while adding identifiers of transited UAVs. Finally, the broadcast will be achieved when all RREQs reach the destination during the waiting time started at the reception of the first RREQ by D .

5.5.2 Routing decision process

When the first RREQ reaches the destination d , it starts a timer to wait during a defined time (*i.e.*, up to 500ms) in order to have the knowledge about all possible paths intercepted in this time interval. After the expiration of the waiting time, all received RREQs are dropped and the routing decision is taken directly by forwarding a RREP packet containing the best path with the best score to the source node. The waiting time does not have any impact on the calculation of the real distribution of vehicles in UVAR-G, since UVAR-G is carried out independently. While, for UVAR-S, since UAVs just hover urban areas, their speed does not exceed 16 m/s. During this waiting time, the UAVs will not have a big variation in their geographical positions compared to their supposed transmission range using the MAC protocol 802.11p (*i.e.*, 1000 m [200, 201]). Indeed, a score is calculated for every discovered sequence of UAVs based on the received information through the RREQs. As shown in Figure 5.6, the destination has the knowledge about three sequences and accurate parameters about all of them (see TABLE 5.5). These information are exploited to know the suitable path.

Δ is the cumulative distance between the destination and the corresponding node through the sequence of UAVs (nodes). Based on these intercepted information as shown in TABLE 5.5, a score is calculated by the destination per discovered $Path$ using the following formula:

$$Score_S = \prod_{i=0}^{H-1} \left[\frac{R_U}{dist(\Delta_{n_i}, \Delta_{n_{i+1}})} \right] \quad (5.7)$$

Table 5.5: Discovered paths.

Path 1		Path 2		Path 3	
Node	Δ	Node	Δ	Node	Δ
$n_0 (s)$	2710.0	$n_0 (s)$	2990.0	$n_0 (s)$	3010.0
$n_1 (uav1)$	2510.0	$n_1 (uav1)$	2790.0	$n_1 (uav1)$	2810.0
$n_2 (uav2)$	1700.0	$n_2 (uav5)$	1800.0	$n_2 (uav5)$	1810.0
$n_3 (uav3)$	990.0	$n_3 (uav3)$	990.0	$n_3 (uav6)$	1100.0
$n_4 (uav4)$	280.0	$n_4 (uav4)$	280.0	$n_4 (uav4)$	280.0
$n_5 (d)$	0.00	$n_5 (d)$	0.00	$n_5 (d)$	0.00

R_U is the transmission range of all UAVs; H is the total number of hops forming the path between the source s and destination d . $dist(\Delta_{n_i}, \Delta_{n_{i+1}})$ is the distance between two successive nodes starting from the source vehicle. Paths with low scores are undesirable, it means that there are long distances between UAVs and they can be quickly broken due to the high mobility of nodes especially for the UAVs characterized by their very high mobility. This is why the path with the highest score will be selected.

- **The Route Reply (RREP) packet format:** Two information are added by the destination to the RREP packet (*c.f.*, Figure 5.8): (i) its geographic location, and (ii) the selected path is included in the RREP packet. The direct links between each UAV are cached in the intermediate nodes in order to be used in the path maintenance.

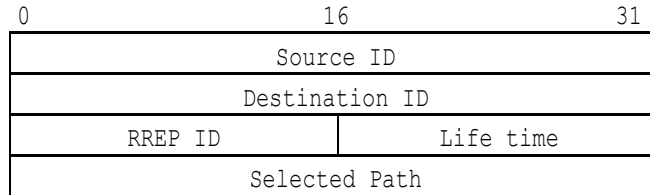

Figure 5.8: The Route Reply (RREP) format.

- **The RREP forwarding:** The path with the best score will be selected ($Path 1$ in blue in Figure 5.6). A RREP packet will be generated and sent unicasting back to the source along the selected succession of UAVs. The source starts the data packets delivery as soon as it receives the RREP packet.

The RREP packet is handled by all nodes as shown in Algorithm 4:

Algorithm 4: UVAR-S (RREP handling)

```
1  $C \leftarrow$  The current vehicle;  
2 if Source (RREP) =  $C$  then  
3   | Data packet delivering();  
4   | // If I am the destination of this RREP, I start the data  
   | packet delivering.  
5 else  
6   | Forwards(RREP, Selected(traversedUAVs));  
7   | // If I am not the destination of this RREP, I will forward  
   | it along the selected traversed UAVs.
```

5.5.3 Recovery process

When the source vehicle S receives the RREP packet, First, S copies all the required information such as the Source ID/Position, the Destination ID/position and the selected path in the header of the data packet. Then, it starts to send the data packet through the selected path. If this path will be disconnected, the first vehicle or UAV that detects this disconnection will check available paths (other links) already recorded in the intermediate node, and try to find alternative paths. If there is an alternative path, it will be selected and the data packet is sent through the new link. Otherwise, a Route Error (RERR) message is sent back to the source which contains the details of the disconnection. Then, the source will re-initiate a new path discovery process.

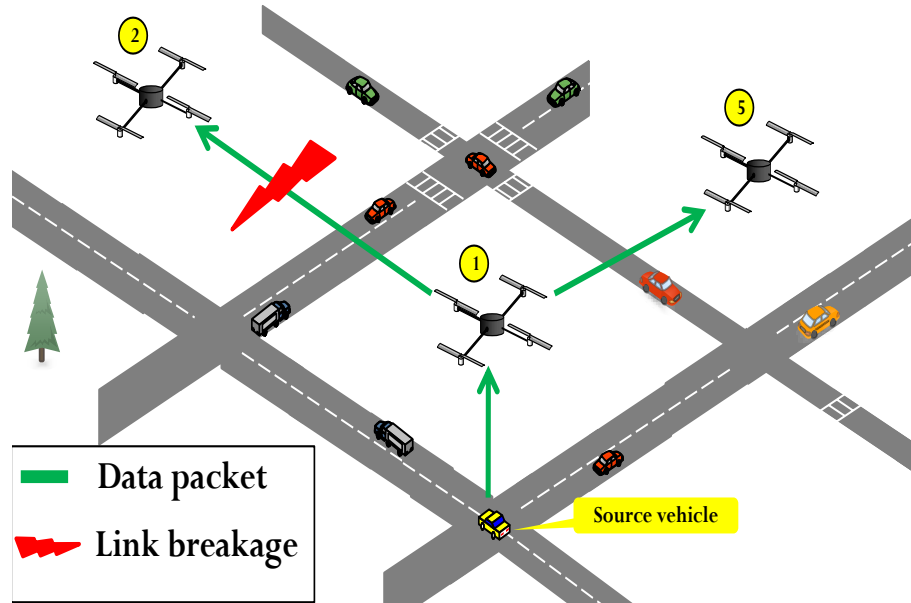

Figure 5.9: Recovery process.

To give an example of the recovery process, consider Figure 5.9 which depicts the $uav1$, $uav2$ and $uav5$ by zooming in Figure 5.6. If for instance, $Path$ 1 is disconnected (i.e., $conn(uav1, uav2) = False$, $uav1$ finds that the communication with $uav2$ is failing and no data packets can be delivered to the destination via this path). Therefore, $uav1$ resorts to the next available path by selecting its next hop (see $Path$ 2 in Table 5.6). After this verification, an alternative path is found through the $uav5$ which will be selected to send the data packet based on the $uav1$, by choosing the closest UAVs (which corresponds to the $Path$ 2) until it arrives at the destination.

Table 5.6: Alternative path.

Path 1		Path 2	
Node	Δ	Node	Δ
n_0 (s)	0.0	n_0 (s)	0.0
n_1 ($uav1$)	200.0	n_1 ($uav1$)	200.0
n_2 ($uav2$)	<i>Fail</i>	n_2 ($uav5$)	1190.0
n_3 ($uav3$)	<i>Fail</i>	n_3 ($uav3$)	2000.0
n_4 ($uav4$)	<i>Fail</i>	n_4 ($uav4$)	2710.0
n_5 (d)	<i>Fail</i>	n_5 (d)	2990.00

The functionality of UVAR is described in Algorithm 5:

Algorithm 5: UVAR-Data packet delivering

```

1 D ← The destination vehicle;
2  $N_c$  ← The set of one hop neighbors of  $C$ ;
3 UVAR-G(packet,D);
4 if  $\exists UAV \in N_c$  then
5   UVAR-S (packet,D);
6 // UVAR-G and UVAR-S can be used in parallel.
7 if  $Score_G \geq Score_S$  then
8   Data packet delivering(UVAR-G);
9   // UVAR-G is selected for delivering data packets.
10 else
11   Data packet delivering(UVAR-S);
12   // UVAR-S is selected for delivering data packets.
```

The two components of UVAR (UVAR-G and UVAR-S) can be executed in parallel by the source vehicle S . However, when the two components respond positively to the request of sending data packets, one component will be executed according to the obtained score. The $Score_G$ and $Score_S$ are calculated by approximately the same method so that they could be compared. However, $Score_S$ can be favored over $Score_G$,

because in UVAR-S, data packets are delivered directly to their target destination. This is not the case of UVAR-G in which routing paths are built gradually at each intersection until it reaches the target destination. $Score_G$ and $Score_S$ are compared by S and the highest one; its component is executed for delivering data packets to the destination D . When the two components fail to reach the destination vehicle D , the current vehicle uses the carry and forward technique until one of the components responds positively to the request.

To have a deep understanding of the UVAR’s functionality, the data delivery methods have to be clarified. Indeed, the current vehicle located at an intersection, which has a data packet to send, has two ways to forward data packets: (i) in the sky exclusively through UAVs or (ii) on the ground exclusively through vehicles. The current vehicle initiates the discovery process in the sky through UAVs. Then, it intercepts from the direct UAV the calculated $Score_G$ of each road segment around. Besides, it can also intercept a possible RREP packet if there is a path through UAVs containing the $Score_S$. The current node selects the best road segment, according to the comparison of scores. After that, the technique with the best score will be selected for delivering data packets to the target destination. UVAR-S is favored over UVAR-G, because the data packets are directly delivered to their target destination using UVAR-S, which can provide the full routing path to the target destination as long as $Score_S > 0$. However, the routing path of UVAR-G is built gradually at each intersection until it reaches the target destination if no path through UAVs exists. In the case when $Score_S \approx 0$, it means that there exists a weak connection between the full path of UAVs or there is no path to the target destination. Only in this situation, UVAR-G is employed to find another suitable intersection to deliver data packets to their target destination.

5.6 Performance evaluations

Having detailed the functionalities of our protocols, now we focus in this section on the performance evaluation of UVAR routing components. To this end, a set of simulations was carried out using the simulation tool NS-2 [203]. To study the performance, we have created a urban scenario (Network topology) close to the reality, with a surface of $4 \times 4 \text{ km}^2$ consisting of 25 intersections and 40 bidirectional road segments (*c.f.*, Figure 5.10).

The network topology is exploited in order to generate the movements of vehicles using VanetMobiSim mobility generator [196]. To generate the movements of UAVs, we have used MobiSim [197] to generate a Random Walk mobility model for 16-80 UAVs covering each area of four road segments. Also, We assume that UAVs maintain a constant altitude that it does not exceed 200 meters during the flight. Table 5.7 recapitulates the rest of the parameters.

Table 5.7: Simulation parameters.

Simulation scenario		Routing	
Parameter	Range of values	Parameter	Range of values
Simulation area	4000m × 4000m	Communication range of vehicles	≈ 300m
Simulation time	180s	Communication range of UAVs	≈ 1000m
Mobility generator	VanetMobiSim [196]	MAC Protocol	IEEE 802.11p
Number of intersection	25	Frequency Band	5.9 GHz
Number of roads	40	Number of packets senders	50
Number of vehicles	80-320	Packet size	1 KB
Number of UAVs	16-80	Channel capacity	1Mbps
Vehicle speed	0-50 km/h	% of nodes requesting data	20 %
UAV speed	0-60 km/h	Evaluation metrics	PDR/EED/OH/HOP

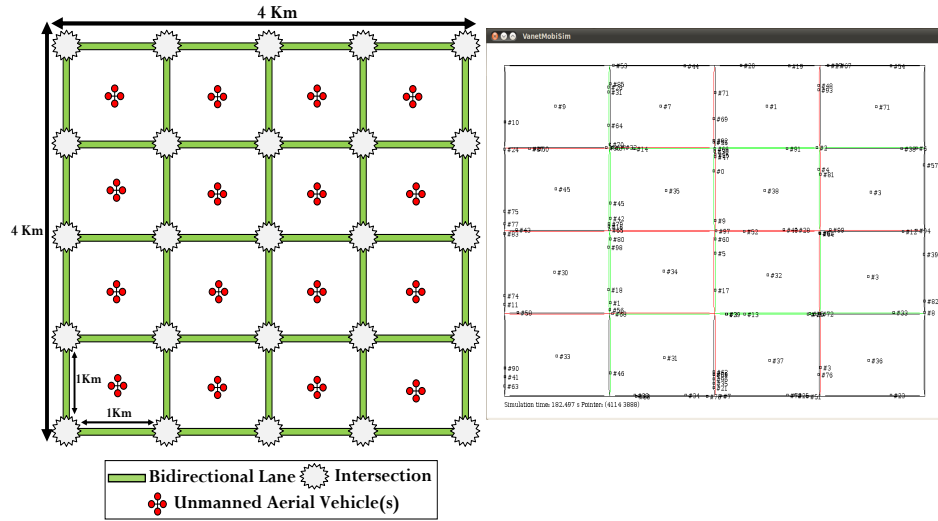

Figure 5.10: Network topology.

5.7 Results analysis

The experiments are carried out with our protocols and other state-of-the-art routing protocols such as GyTAR and ETAR which are position-based delay tolerant routing protocols for VANETs, where their implementations are taken from [160] and [159] respectively. UVAR protocols are also compared with AODV [149] which is a MANET routing protocol and its implementation was provided by NS-2.34.

Firstly, the tests are run under different vehicle densities: (i) 80-140-vehicles shows sparsely connected networks, (ii) 160-220-vehicles shows medium-dense networks, and (iii) 240-320-vehicles shows well-connected (dense) networks. Secondly, the tests are run under different UAV's densities: (i) 16 UAVs shows relatively low UAVs' density, (ii) 32-48 UAVs shows a medium UAVs density, and (iii) 64-80 UAVs shows a highest UAVs' density. The initial positions of vehicles are distributed uniformly on the net-

work. In addition, we also fixed traffic lights at each intersection where their period is set to 40s.

In the simulation, we set the transmission range of each vehicle to ≈ 300 m with a 100% probability of success for communications on the ground. For UAVs, the transmission range is set to ≈ 1000 m with an 80% probability of success for communications. We note that when vehicles want to establish a communication with UAVs, the transmission range of vehicles is set to ≈ 1000 m with a 70% probability of success for communications. These values are selected based on several executed scenarios in the simulation.

For more accuracy on neighboring vehicles and UAVs, we set the Hello interval to 0.1 s and clear list of neighbors after 1 s of inactivity. The IEEE 802.11p standard is adopted at the MAC layer for all nodes, since we used different types of nodes (Vehicles and UAVs).

As evaluation metrics, we consider the following measured parameters: Packet Delivery Ratio, End-to-End Delay, average number of hops, and the overhead.

5.7.1 Average delivery ratio

In this part, we compare the delivery ratios under different vehicle and UAV densities for the evaluated protocols. As seen in Figure 5.11(a), UVAR-G and UVAR-S achieve much higher delivery ratio than other routing protocols thanks to their used mechanism based on the UAVs ensuring a significant accuracy of calculations of the routing path selection. Here, UVAR-S has a slight advantage over UVAR-G, this is because UVAR-S does not rely on vehicles to deliver the data packets, but it is based exclusively on UAVs, which permits to guarantee a constant connectivity compared with vehicles on the ground due to their large transmission ranges. We also notice that ETAR and GyTAR in their calculations of the routing path selection are based on the collaboration of the existing vehicles on the segments, which cannot always be done accurately leading to the selection of inappropriate paths, resulting in their lower delivery ratios. AODV achieves the lowest PDR in different vehicle densities since it is a reactive topology-based routing protocol calculating the totality of the routing paths without taking into consideration the high mobility of vehicles resulting in high packet losses.

In the variation of the UAV densities in Figure 5.11(c), we clearly see the high PDR achieved by UVAR-S as the number of UAVs increases. This is principally due to the use the reactive mechanism which selects the closest UAVs of each other in order to ensure a long lifetime of connectivity (as explained before) and consequently decreases considerably the packet losses. However, we distinguish certain stability in the PDR of UVAR-G, because UAVs are only used to calculate the traffic density variation and the connectivity on the segments. When the number of vehicles is fixed to 200, the number of UAVs does not have any impact on the delivery ratio of UVAR-G.

Figure 5.11(b) shows the boxplot of the average PDR obtained by varying the density of vehicles (80-320) for all the compared routing protocols. We clearly see that with UVAR-S we maintained over 85% of received packets which is a high rate compared to other protocols. We also notice the 25% accomplished by ETAR which is considered as the lowest rate of successfully received packets. This great difference is explained by the used techniques applied by the routing protocols which all aimed at increasing the packet reception rate.

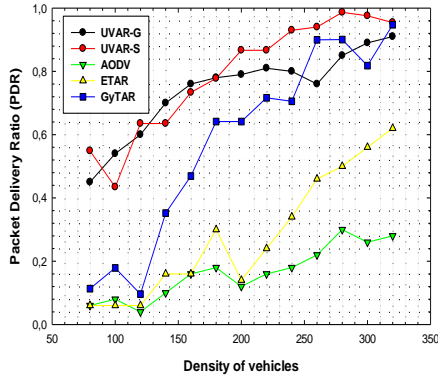

(a) PDR vs. Density of vehicles (UAVs=16).

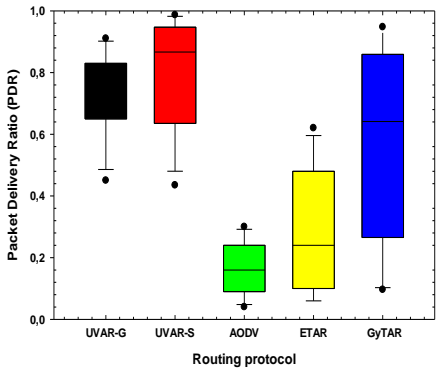

(b) Average packet delivery ratio.

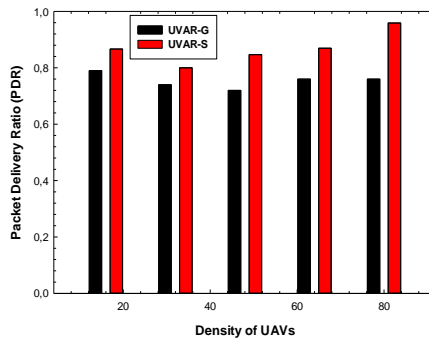

(c) PDR vs. Density of UAVs (Vehicles=200).

Figure 5.11: Packet Delivery Ratio vs. Density of nodes (Vehicles/UAVs).

5.7.2 Average delay

Figures 5.12(a) and 5.12(c) illustrate the average end-to-end delay for the different vehicle's and UAV's densities. We can observe that UVAR-G has the lowest average delay which demonstrates the best performance compared with other evaluated protocols. In Figure 5.12(a), overall, we denote that the delay decreases whenever the density increases except for UVAR-G which shows the lowest and stable delay whatever the vehicles' densities. This is due to two reasons. First, the constant use of the existing UAVs in range which support the computing of accurate scores leads to the correct selection of the appropriate road segment. Second, the short distances traveled by the data packets to the target destination minimize significantly the average delay. However, we can clearly distinguish the extra time taken by UVAR-S due to the discovery process initialized before delivering each data packet to select the optimal succession of UAVs to the target destination. GyTAR and ETAR do not perform as well as UVAR-G and UVAR-S, this is because the use of the carry and forward technique causing additional delay when the links break on the road segments due to the high mobility of vehicles and the imprecise calculations caused by the problem of collision generated by the exclusive collaboration of vehicles (as explained before). AODV achieves the highest delay which can be justified by the fact that its discovery process is not adequate to the high mobility which may require several path discoveries at each broken path.

From the simulation, Figure 5.12(c) depicts that the average delay of UVAR-S increases whenever the number of UAVs increases for each area of the four road segments. This is explained by the time required by UVAR-S to discover the optimal path to the target destination which will be considerably increased when the network becomes highly dense. However, in general, it is clearly shown that the delay taken by UVAR-G is stable whenever the number of UAVs increases. This is because the number of UAVs has no relationship with the functioning of UVAR-G which needs only one UAV per area of four road segments to work correctly.

In Figure 5.12(b), the two components of our protocol UVAR show the shortest response time to the data packet requests compared with other routing protocols with the same density of vehicles scenarios (80-320). However, the box plot of AODV demonstrates the worst performance in terms of delay. This is due to the way AODV manages the data packet delivery, which is based essentially on the topology causing frequent path failures, and consequently repeated discovery process and hence, the shown extra time. The techniques used by the rest of the protocols whether reactive or not, all have one goal, which is to minimize the delay of packets delivery. As a result, we can say that the routing protocols based on the geographic positions are the most suitable for the high mobility which characterizes VANETs.

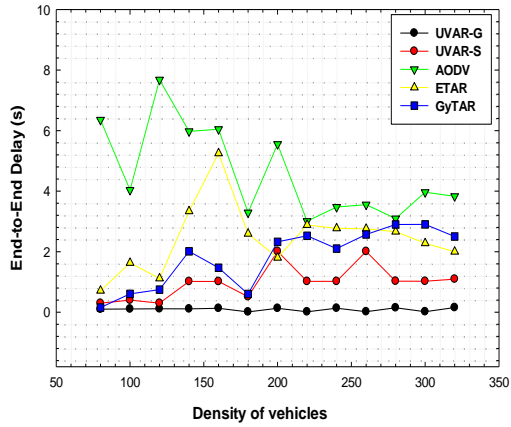

(a) EED vs. Density of vehicles (UAVs=16).

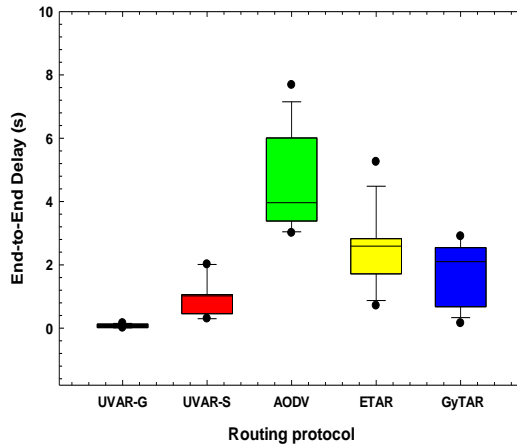

(b) Average EED.

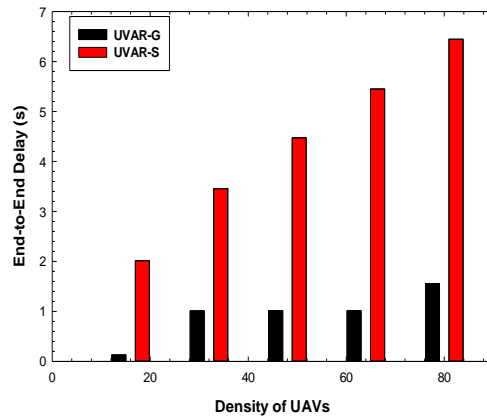

(c) EED vs. Density of UAVs (Vehicles=200).

Figure 5.12: End-to-End Delay vs. Density of nodes (Vehicles/UAVs).

5.7.3 Overhead

The curves in Figures 5.13(a) and 5.13(c) show the control overhead when the density of vehicles and UAVs varies. In the Figure 5.13(a), it can be seen that the control overhead, gradually increases as the density of vehicles is increased for both UVAR-S and AODV, whereas there is no significant increase in UVAR-G and ETAR, which they generate less overhead packets, in which their number are approximately constant since they do not use any additional packets except the periodical exchange of Hello packets. However, GyTAR has two control messages which are periodically broadcasted what explains the additional overhead packets generated compared with UVAR-G and ETAR.

For the reactive protocols UVAR-S and AODV, we can observe the proportional relationship between the control overhead and the number of nodes. In general, UVAR-S generates fewer overhead packets than AODV; this is due to the reduced number of UAVs compared with vehicles and the mechanism of maintenance used by UVAR-S which exploits alternative paths (as explained before). However, AODV generates more overhead packets this is because AODV is not appropriate for the high mobility of our system. In addition, AODV generates more RERR due to the frequent disconnections occurred on the network.

As shown in Figure 5.13(c), we denote that in most cases, UVAR-S generates more overhead packets as the number of UAVs increases. This is mainly due to the generated extra routing packets (RREQ, RREP, and RERR) as the number of UAVs increases, which confirms the aforementioned explanations about UVAR-S discovery process. However, UVAR-G remains approximately constant as the number of UAVs increases. This is because UVAR-G does not use the discovery process in the data delivery and consequently, it has no relationship with the additional UAVs.

For the control overhead, the Figure 5.13(b) shows almost no overhead for UVAR-G and ETAR because they do not use any additional routing packets in the data packet delivery. However, for the other protocols, we notice the using of additional packets both in the discovery process for the reactive ones and in the data delivering for others. UVAR-S demonstrates lower overhead than AODV. This is because, first, because UVAR-S executes the discovery process through a limited number of UAVs; second, the discovery process is not re-initiated directly when there is a path failure.

5.7.4 Average number of hops

Figures 5.14(a) and 5.14(c) illustrate the average number of hops with different vehicle's and UAV's densities. As it is noticed in Figure 5.14(a), we observe that the number of hops of all the evaluated protocols has a proportional relationship with the density of vehicles, except for UVAR-S, where we see a stable behavior of the average number of hops whatever the number of vehicles. This is explained by the

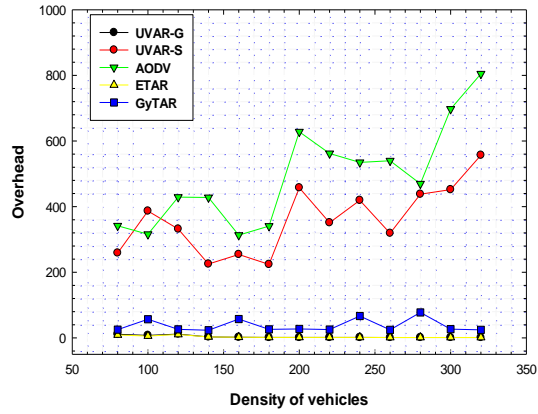

(a) OH vs. Density of vehicles (UAVs=16).

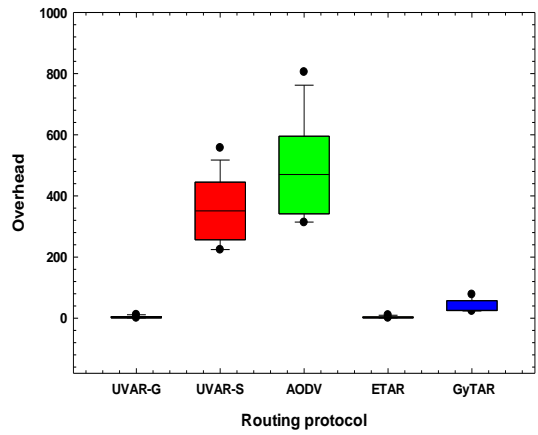

(b) Average overhead.

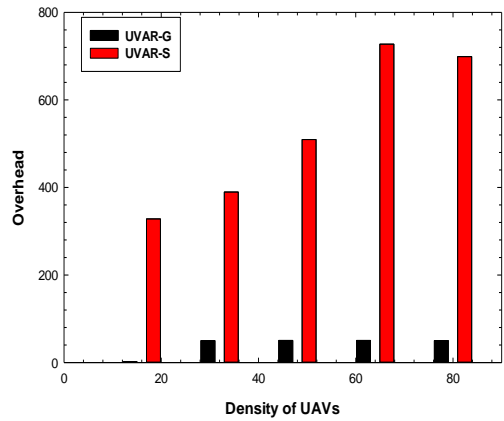

(c) OH vs. Density of UAVs (Vehicles=200).

Figure 5.13: Control Overhead vs. Density of nodes (Vehicles/UAVs).

constant number of UAVs (16) for packet delivery and no exploitation of vehicles on

the ground. For the other protocols, we can distinguish two interesting trends. First, the density of vehicles between 80-240 has a stable number of hops for all protocols explained by the low density of the network and the different mechanisms used by them which minimize the distance traveled by the data packets. Secondly, the density of vehicles between 240-320 is considered as high density and consequently the average number of hops becomes bigger and bigger. This is mainly caused by the long distances between the sources and the target destinations in which the protocols select paths with a high density of vehicles without taking into consideration the number of junctions.

As depicted in Figure 5.14(c), we can see that UVAR-S outperforms UVAR-G with the help of the use of the UAVs to deliver the data packets which minimizes the average number of hops by avoiding unnecessary hops especially when the network is highly dense. The figure also shows that the average number of hops increases as the number of UAVs is increased. This is because UVAR-S selects the path composed of UAVs, which are closest to each other. However, the average number of hops of UVAR-G is very high. This is essentially due to the important distances traveled by the data packets since UVAR-G is based only on the vehicles on the ground. In addition, in UVAR-G, the distance between the source and the destination does not have a great impact especially when the ground is sparsely connected, and it favors the density as a selection factor.

The simulated average number of hops is shown in Figure 5.14(b). The best result is obtained by UVAR-S, which demonstrates the smallest number of hops. This is because it is the only protocol which delivers the data packets in the sky using a limited number of UAVs and consequently resulting in fewer hops to the target destination.

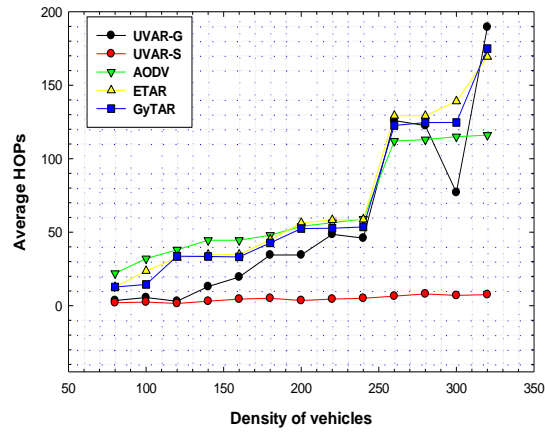

(a) HOP vs. Density of vehicles (UAVs=16).

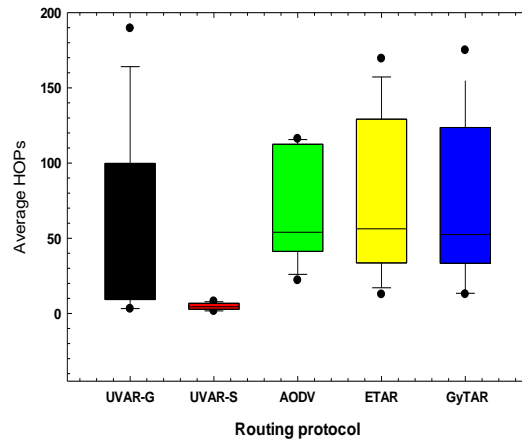

(b) Average number of hops.

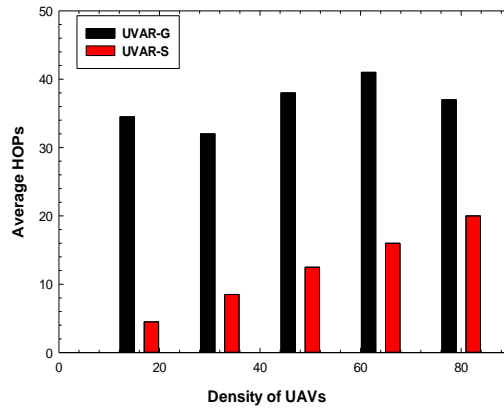

(c) HOP vs. Density of UAVs (Vehicles=200).

Figure 5.14: Average number of hops vs. Density of nodes (Vehicles/UAVs).

5.8 Conclusion

In this *chapter*, we presented the UVAR protocol and its extension to support ad hoc routing between UAVs and VANET as well as between UAVs themselves. UVAR protocols are dedicated for urban vehicular environments, whose main objective is to improve the performance of routing based on the UAVs awareness of the road traffic in the ground. Here, we presented a set of two protocols: UVAR-G for ground-to-air communication and UVAR-S for air-to-air communication. First, UAVs are used to estimate the vehicular density within a given road segment by monitoring and exchanging Hello message with vehicles on the ground. UAVs are then used to assist vehicles in selecting communication routes for routing their data. Secondly, and through UVAR-S, UAVs are also used to route data packets through UAVs when communication on the ground is deemed poor or when the vehicular density is not enough to route packets through vehicles. We have conducted a simulation-based performance evaluation of our UVAR protocols, and shown UVAR's effectiveness and robustness in terms of the added reliability of the routing, the reduced delay, and improved delivery ratio compared to other existing state-of-the-art routing protocols. As future work, UVAR protocols will be improved on the security side and adapted to other environments such as highways and rural.

UVAR is composed of two components working together, but with completely different methods. This protocol can be considered as a complex concept since two process are executed in parallel based on two different entities (*i.e.*, UAVs and vehicles). It will be more simple to consider UAVs and vehicles as full members of existing VANETs. All the entities of the road as well as those of the sky can participate in the routing process, each one with its own particularities and limitations. Furthermore, it is preferable to use a unique method for the routing process in order to unify the nodes' behaviors towards the data exchange.

In the next *chapter*, we introduce our last contribution which is in the form of a reactive routing protocol destined for city environments. This protocol is based on forwarding packets using the densest (connected) and stable path which includes the fastest path in term of delay. Improved techniques are used in the discovery process that aim to minimize the delay and the control traffic overhead. In the case where there are several discovered paths, a scoring technique is used to select the optimal path based on several criteria. The route maintenance process is ensured based on two steps: (i) another alternative path can be used in each path breakage without re-initiating the discovery process. When there is no routing path, (ii) UAVs are used to establish a connection between the two disconnected clusters in order to create an alternative path.

Chapter 6

UAV-Assisted Reactive Routing for Urban VANETs

Contents

6.1	Introduction	115
6.2	Assumptions	116
6.3	Identification of fixed zones	118
6.4	Discovery phase	119
6.4.1	The route request (RREQ) packet format	119
6.4.2	Prediction of the path expiration	120
6.4.3	Principle of the flooding	123
6.5	Selection phase	126
6.5.1	Scoring calculation	126
6.5.2	The route reply (RREP) packet format	129
6.6	Data delivery phase	132
6.7	Maintenance phase	133
6.8	Evaluation	136
6.8.1	Results analysis	137
6.8.2	Packet delivery ratio (PDR)	137
6.8.3	End-to-End delay (EED)	139
6.8.4	Overhead (OH)	141
6.8.5	Average number of hops (HOP)	143
6.9	Conclusion	145

6.1 Introduction

VANETs are characterized by frequent path failures due to the high mobility caused by the sudden changes of vehicle's direction. The routing paths between two different vehicles should be established with this challenge in mind. They must be stable and well connected in order to guarantee a reliable and safe delivery of packets. Indeed, numerous routing challenges need to be addressed in order to adapt the proposed solutions to the unique characteristics of VANETs, and especially to the highly dynamic movements of vehicles (various speeds and directions). Most of the reactive routing protocols for VANETs only indicate the presence or absence of routing paths between two vehicles. Also, they use a recovery process when a link-breakage takes place. When there is a path failure, a significant delay is diagnosed in the initialization of a new path discovery. In addition, most of them do not take into account whether the discovered path is dense with vehicles, which is crucial to increase the chances of a successful delivering data packet between a source and destination. When the network is sparsely connected (no existing paths), these protocols cannot forward the data packets because their route maintenance process fails to find a new path, and consequently, the data packets cannot reach their final destination.

The aim of this *chapter* is to present a new reactive routing technique providing effective and well-regulated communication paths [11]. These discovered paths are created based on a robust flooding discovery process involving UAVs to ensure the connectivity when the network is sparsely connected. Moreover, this routing protocol takes into account the real distribution of vehicles on the discovered paths based on scoring technique involving many criteria. In addition, UAVs may belong to the discovered paths and it can also be used as forwarding nodes connecting disconnected clusters when the network is poorly dense. The main idea behind this approach is to exploit the discovery phase to have an accurate vision about the traffic density in each discovered path. A multi-criteria score is given to each discovered path based on the real distribution of vehicles and the end-to-end delays. However, in some situations, the selected path that was created between a pair of source and destination nodes cannot remain constant due to the high mobility of nodes. This is the reason why we use an intelligent route maintenance process using alternative paths discovered beforehand and stored in the source. In addition, a prediction technique is employed to define the expiration time of each discovered path and also used as a metric during the maintenance phase when there is a path failure. UAVs can play a role of a routing assistant, both in the discovery process and during the recovery strategy. The evaluation of this approach is performed using NS-2 simulator and its performances are compared with on-demand protocols dedicated for VANETs. Simulation results show clearly that our approach gives interesting outcomes ensuring a high delivery ratio with a minimum delay. This hybrid communication between the vehicles and UAVs is attractive to initiate smarter connected nodes in the near future.

6.2 Assumptions

Let us detail the different assumptions taken into account by our approach. Each node (Vehicle/UAV) in the network is equipped with a global positioning system (GPS) to define its geographical position. The network is supposed to be divided into identified fixed zones and the nodes use a digital map to know the positions and identifiers of all fixed zones. All nodes maintain and update their own routing tables. There is no energy restriction since each node is equipped with rechargeable batteries, which are continuously recharged as vehicles or UAVs moving. Also, batteries may be powered by the resources of nodes such as solar energy, gasoline, electrical energy, *etc.* Vehicles and UAVs are equitably distributed on the network and can exchange data packets through integrated wireless interfaces using IEEE 802.11p at the MAC layer, which is widely adopted by the industry and considered as the most suitable for vehicular communications [202]. In our case, the wireless interfaces can provide five possible kinds of wireless communications (*c.f.*, Figure 6.1(c)) as follows:

- **Vehicle-to-Vehicle (V2V):** vehicles on the ground within the communication range of each other and line of sight can communicate. In the case where there is an obstacle, the communication is not possible.
- **Vehicle-to-UAV (V2U):** vehicles and UAVs can communicate with each other. We note that we use UAVs in the form of small Quad-Copters, which fly at low and constant altitudes (*i.e.*, do not exceed 300 m during the flight). Overall, Quad-copters in urban areas do not fly at high altitudes since most of their applications need to be done at low altitudes such as in [198] and in our selected simulation scenario. This restriction is imposed in order to avoid restricted flight zones reserved for other aircraft [204].
- **UAV-to-UAV (U2U):** UAVs can exchange data if they are within the communication range of each other.
- **Vehicle-to-Road-Side-Unit (V2R):** a communication link is established between RSUs and existing vehicles only when certain applications need to be run such as Internet access.
- **UAV-to-Road-Side-Unit (U2R):** Several UAV-based applications require Internet access for their right functionality [205]. UAVs establish a connection with an RSU in range either to supply their current applications or to relay data packets from another node in the network.

Each road segment and the airspace are assumed to be divided into identified fixed zones (*e.g.*, see Figure 6.1(a) and 6.1(b)). The size of each zone depends on the communication range of vehicles and UAVs ($\approx 300\text{m}$) for the roads and the sky, respectively.

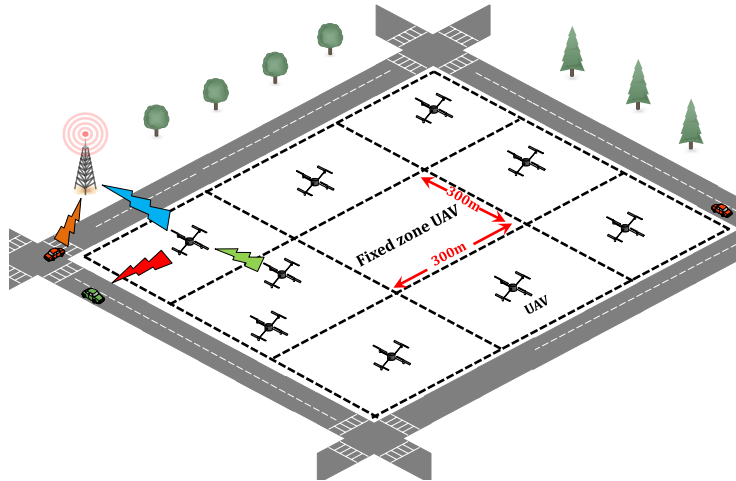

(a) Airspace divided into fixed zones.

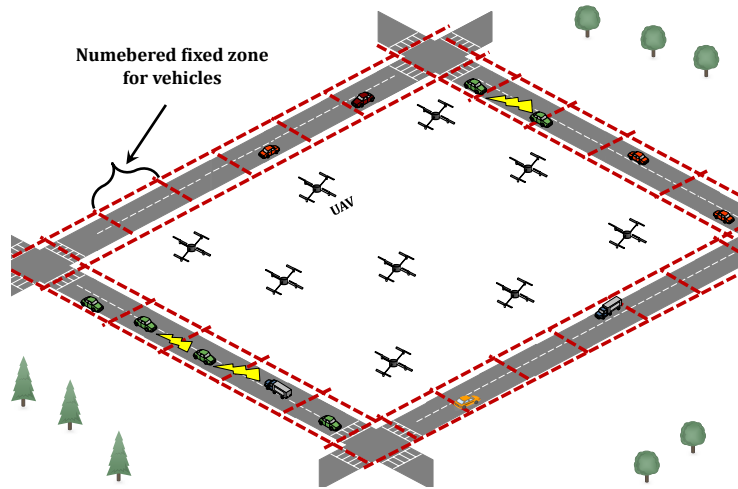

(b) Road segments divided into fixed zones.

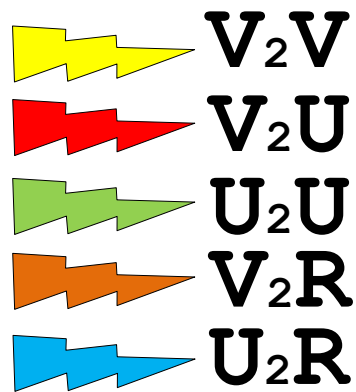

(c) Existing kinds of wireless communication.

Figure 6.1: Network topology.

In the next subsections, we outline the execution phases of our routing approach. Four steps (phases) are required to be done in the order so that to provide a high level of correct functionality of the proposed approach. Each phase has to be done separately, in which the fixed zones can play a crucial role in its smooth execution.

6.3 Identification of fixed zones

The identification phase of fixed zones is carried out both in the sky and on the ground. Our network is divided into several fixed zones identified by a unique ID (*e.g.*, Figure 6.2), since our approach is not based on the nodes but it is based exclusively on the zones. This decomposition is crucial for the knowledge of important information such as the traffic density, the real distribution of the nodes (vehicles and UAVs), and the exact location of link breakages when they occur. In addition, it can also help to find alternative solutions to avoid sparsely connected zones towards the target destination during the data delivery phase. The identity of each zone is supposed to be known by all vehicles and UAVs using their included digital map.

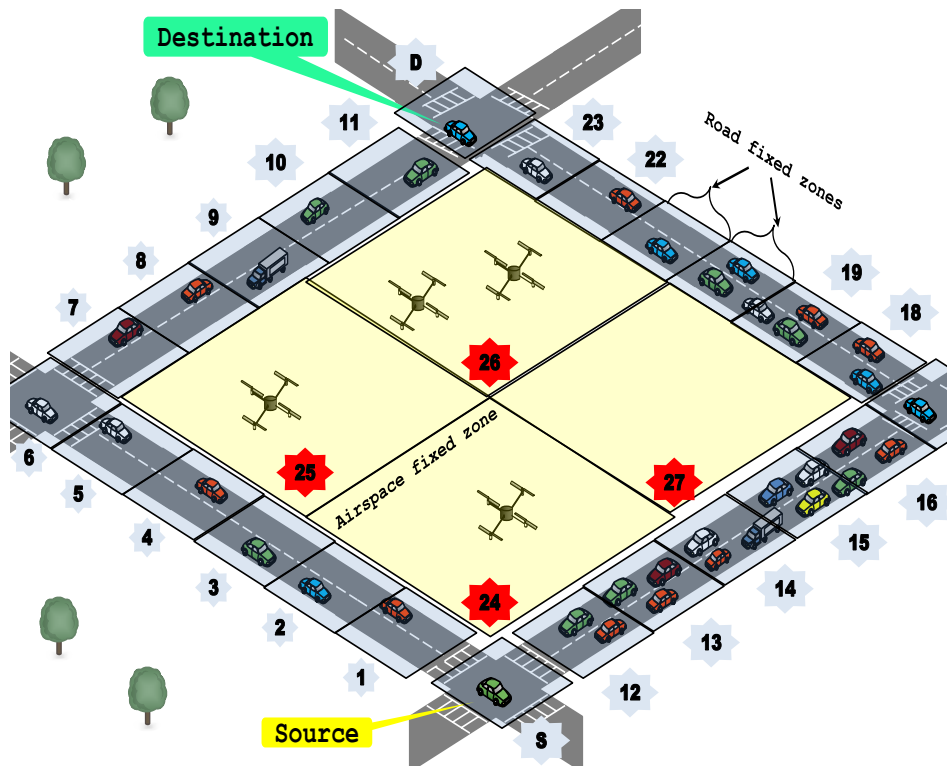

Figure 6.2: Phase of the identification of fixed zones.

6.4 Discovery phase

When there is a possible need to send a data packet to a particular node (fixed/mobile), the discovery phase is initialized to get all possible paths to the target destination. In the discovery phase, the source node uses the flooding technique by broadcasting a Route Request (RREQ) packet across the network through all existing nodes. This broadcast allows the source vehicle to discover all existing paths in the form of zones' succession towards the target destination. Also, the discovery phase allows to get the geographic position of the destination node and its zone of location as well.

Furthermore, during the flooding process, the paths are built gradually. At the same time, several other parameters can be progressively calculated such as the traffic density, the real distribution of vehicles, the path expiration time, and the connectivity degree of each discovered path. Robust and well-stable paths are ideally desired by our approach so that to be used as data relaying paths in order to support both the data delivery and maintenance phase. Each path is represented by a succession of zone ID, which are stored in the routing table of each node as a sequence number (*SN*). *SN* is used both by the target destination and intermediate nodes to differentiate with an accurate way between the discovered paths. The full paths cannot be stored, neither in the control packets (RREQs and RREPs) nor in the exchanged data packets due to their static size. All these criteria make the originality of our flooding process compared with traditional flooding techniques used by other protocols proposed in the literature.

6.4.1 The route request (RREQ) packet format

As depicted in Figure 6.3, several fields characterize the RREQ packet. The *RREQ ID* field defines the discovery phase to which the RREQ packet belongs. The *Delay* field represents the time needed for data delivery. The *Life time* field represents the time duration of the flooding, which is initially set to a certain value. If *Life time* reaches its expiration, the RREQ will be dropped in order to limit the permanent flooding of the entire network. The *Identifiers* of the source *S* and the destination *D*. The *Movement information* field is used to calculate the expiration time of the transited path, where intermediate nodes modify it at each hop by adding the required information about their movements (*i.e.*, velocity, speed, and position). This allows to estimate the lifetime of an existing wireless link between two successive nodes. The *DisZone* field represents the disconnection zone, which defines the weakest connected zone (*i.e.*, the links between its nodes are the weakest one in the discovered path). The *SN* field corresponds to a unique path, which exists between the source and the target destination. *SN* is stored in the routing table of nodes in each transited zone. The number of transited zones *Zone count*, the total number of nodes in the path $N(Z)$, and the real distribution of nodes in the path σ are the

parameters of a score, which will be calculated at the end of the flooding.

0	16	31
Flooding ID		
Delay	Life time	
Source		
Destination		
Movement information		
Zone count	N(Z)	σ
PE (s)	DisZone	SN

Figure 6.3: Route Request (RREQ) Format.

6.4.2 Prediction of the path expiration

The path expiration time PE of a given path is defined as the minimum lifetime on a specified wireless link between two successive nodes belonging to this path. Each node exploits the *Movement information* field, which contains the mobility parameters of its previous node such as the geographical location, velocity, and speed, all included in the received RREQ packet. With its own movement information, the current node calculates the lifetime of the link. This value is then used to modify the PE field (*c.f.*, Figure 6.3). The modification is done if, and only if, the value of the already included PE in the RREQ packet is higher than the calculated lifetime of the new wireless link. After that, when the target destination makes the selection phase, it selects the path with the highest PE in order to be used as a transition path to transmit the RREP packet. Then, it is used by the source S to transmit the data packet to the target destination D .

As a basic step, when a node in the network is willing to send a data packet to a specific node, it generates a RREQ packet. Before proceeding to the flooding of this generated RREQ, the requesting node encloses its own mobility details (location, speed, velocity) and other information in other fields (*as mentioned before*) all encapsulated into the RREQ packet. Initially, the path expiration time PE is initialized to a maximum value. Then, the flooding process is started by the source node S . When an intermediate node receives the RREQ packet for the first time, it extracts the broadcaster mobility details and uses them with its own ones in order to calculate the new PE . The PE field is modified on the new generated RREQ if the lifetime of this wireless link is smaller than PE already included.

As an illustration, we take the example of Figure 6.4. Let two nodes a and b with nonzero speeds v_a and v_b , R as the transmission range of the two nodes, (x_a, y_a) and (x_b, y_b) are their coordinates, and θ_a and θ_b are their velocity angles, respectively.

Based on all this information, the lifetime of the link between the nodes a and b is calculated by using the same method in [206] as follows:

$$PE = \frac{-(ij + km) + \sqrt{(i^2 + k^2)R^2 - (im - jk)^2}}{i^2 + k^2} \quad (6.1)$$

Where,

$$i = v_a \cos \theta_a - v_b \cos \theta_b$$

$$k = v_a \sin \theta_a - v_b \sin \theta_b$$

$$j = x_a - x_b$$

$$m = y_a - y_b$$

Consider the case when the vehicle a broadcasts a RREQ to all its neighbors as depicted in Figure 6.4. When the vehicle b located in the zone number four receives the RREQ broadcasted by the vehicle a , it calculates the lifetime of the link that connects it with the node a using the equation (6.1). If the calculated lifetime of the link is smaller than the PE value already included in the received RREQ, it will be modified with the $DisZone$ field (*i.e.*, zone ID of vehicle b). If it is the case, PE is modified by the new lifetime of this link and $DisZone$ is modified by the identifier of the current zone, which is currently considered as an eventual disconnection zone. Otherwise, the node b adds its own movement details (*i.e.*, velocity, speed, and position) and other information necessary for the rest of the flooding process. Then, the RREQ packet is re-broadcasted and so on until a route to the target destination is found.

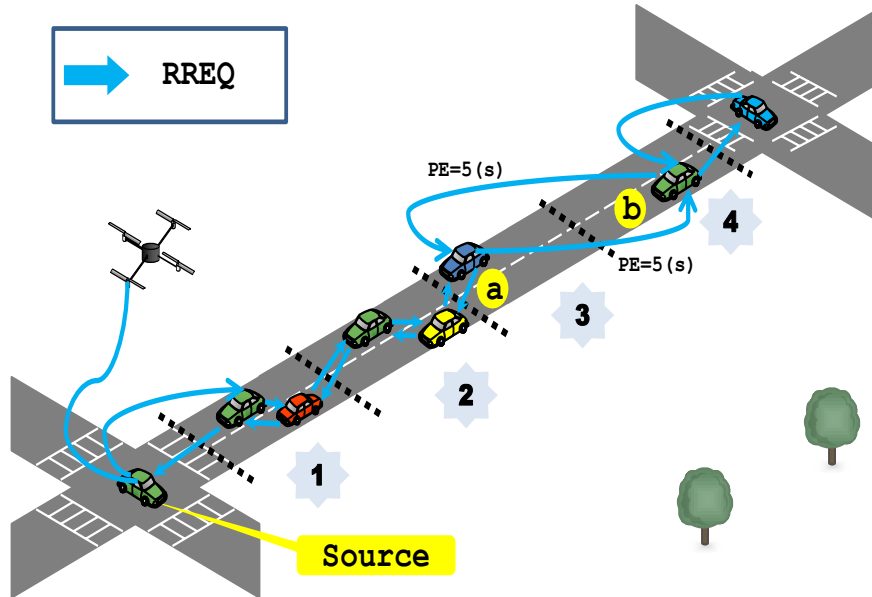

Figure 6.4: Path expiration calculation.

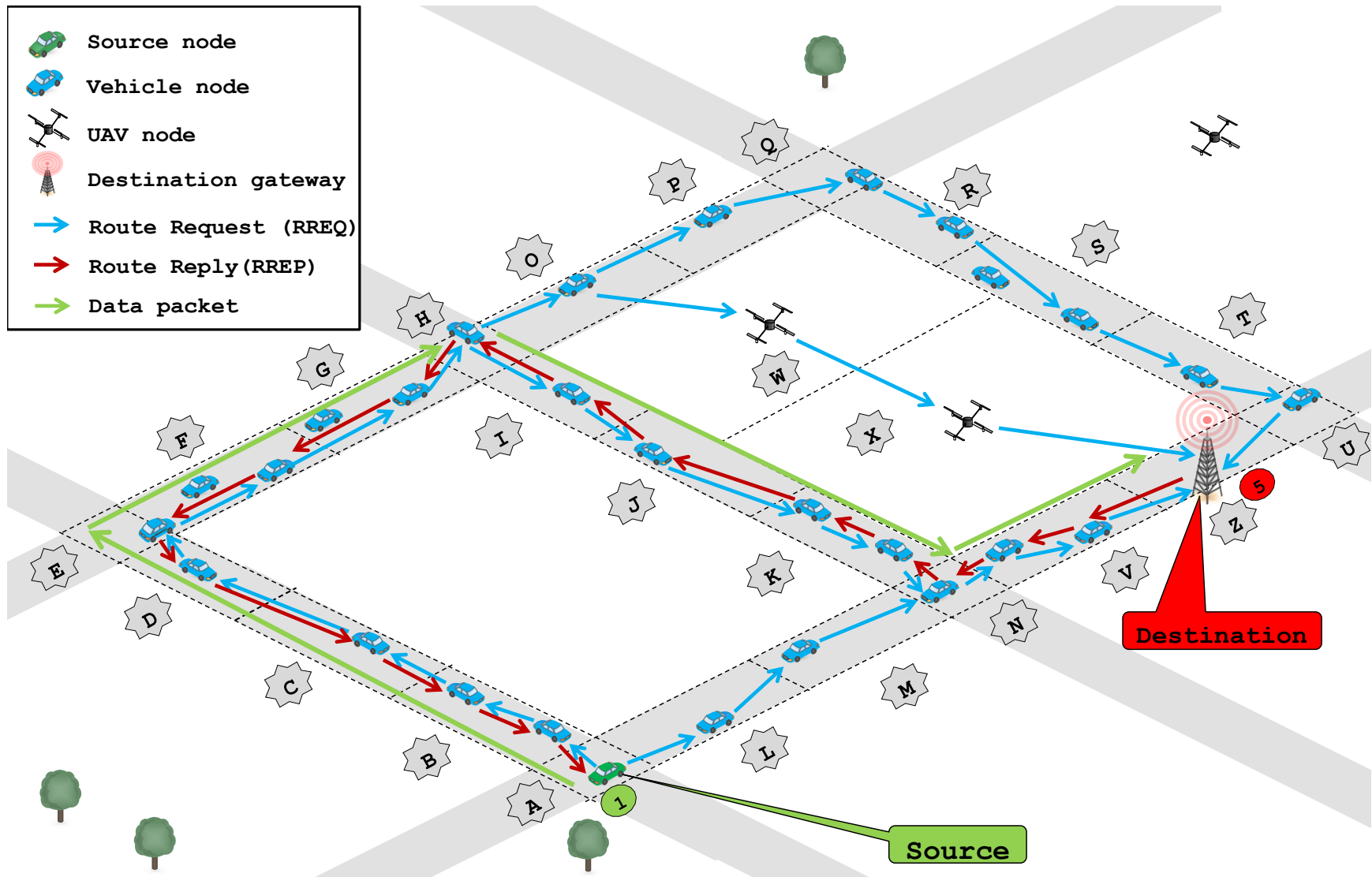

Figure 6.5: Principle of functioning of the discovery phase.

6.4.3 Principle of the flooding

The routing paths are gradually discovered and built to the target destination using a flooding technique. To give an example of the flooding principle, consider Figure 6.5 which depicts the source *vehicle1* located in the zone *A* and the fixed destination *gateway5* located in the zone *Z*. If for example, *vehicle1* has a data packet to send to *gateway5*, it starts broadcasting a RREQ packet to find all possible paths to the destination as well as to get its geographic information and its zone ID. The flooding process is assigned a unique ID and each discovered path is defined with a unique sequence number (SN), which helps to reduce the broadcast storm effect. If a received RREQ has the same SN and Flooding ID as a previously received RREQ, it is automatically discarded. Furthermore, a RREQ cannot make a reverse path of an already transited path. Otherwise, all necessary information included in the RREQ is cached in the routing table of the current node, and then, updated in the RREQ, which will be then re-broadcasted.

At the first step, we remark that there are two possible paths towards the target destination. From the zone *A*, *vehicle1* starts the broadcast of the RREQ packet in all directions (*i.e.*, it broadcasts the RREQ to its two neighboring zones *L* and *B*). Based on the next zones *B* and *L*, we define two different sequence numbers (SNs) $SN = B$ and $SN = L$, respectively. These *SNs* represent two different paths towards the destination (*i.e.*, the first path from *B* and the second one from *L*), which are included in two different RREQ packets and broadcasted by the *vehicle1* each in turn.

Routing Table (Zone A)				
Prev. Zone	Next Zone	Dest. ID/Zone	Flooding ID	Flooding SN
-	B	5	01	B
-	L	5	01	L
...

Figure 6.6: Routing table of the *vehicle1*.

Two routing entries are added to the routing table of the *vehicle1* (*c.f.*, Figure 6.6), which represent two different paths towards the target destination. Useful information is also included in the routing table such as the neighboring zones, a unique *SN* for each entry, the same flooding ID for both entries, and the identifier of the target destination ($ID = 5$). If a path will be selected for data transmission, all this information will be eventually used during the data delivery.

At the reception of the broadcasted RREQ by the vehicle located in the zone *C*, a new routing entry is added in its routing table (*c.f.*, Figure 6.7(a)). Similar information is included as in the routing table of the *vehicle1* with the same *SN* value as in the RREQ, since it is considered as the same path. Nevertheless, for the

case where there are at least two next neighboring zones, the SN field has to be modified. We take as an example the zone H , which has two next connected zones I and O . The forwarding vehicle located in this zone assigns the same SN for the zone I ($SN = B$) considering it belonging to the same current path, however, to the zone O , it assigns $SN = O$ considering it as a different path. This information is updated by adding two entries in the routing table of the vehicle located in the zone H to differentiate between the two paths (*c.f.*, Figure 6.7(b)).

There is a case where a vehicle receives two RREQs coming from different paths, which are known from their SN fields. We take as an example the vehicle located in the zone N , which receives two RREQs from two different paths recognized based on their SN s. It will carry out two different broadcasts to the only next zone V (*i.e.*, RREQs cannot make the reverse path through K or M). The target destination will receive two different RREQs, with two different SN s, and representing two different paths. The routing table maintained at the zone N is updated by adding two entries, representing two different paths with different SN s ($SN = B$ and $SN = L$) according to the received RREQs (*See* Figure 6.7(c)).

Routing Table (Zone C)				
Prev. Zone	Next Zone	Dest. ID/Zone	Flooding ID	Flooding SN
B	D	5	01	B
...

(a) Routing table maintained at the zone C.

Routing Table (Zone H)				
Prev. Zone	Next Zone	Dest. ID/Zone	Flooding ID	Flooding SN
G	I	5	01	B
G	O	5	01	O
...

(b) Routing table maintained at the zone H.

Routing Table (Zone N)				
Prev. Zone	Next Zone	Dest. ID/Zone	Flooding ID	Flooding SN
K	V	5	01	B
M	V	5	01	L
...

(c) Routing table maintained at the zone N.

Figure 6.7: Routing tables in crucial points during the flooding process.

The RREQ packet will be handled by all nodes as shown in Algorithm 6:

Algorithm 6: RREQ handling

```

1 C ← The current node;
2 S ← The source node;
3 D ← The destination node;
4 RTC ← The routing table of C;
5 if (S(RREQ) = C) or ((RREQ ID and SN) ∈ RTC(C)) then
6   Drop (RREQ);
7   // If I am the source of this RREQ or I already received it,
   it will be dropped.
8 else
9   if D(RREQ) = C then
10    Goto selection phase;
11    // If I am the destination of this RREQ, make the routing
    decision.
12  else
13    Store (RREQ ID,SN,RTC(C));
14    Update (Zone count,N(Z),SN,PE,DisZone,σ);
15    Rebroadcast (RREQ);
16    // Update all necessary information in the RREQ and
    rebroadcast it.

```

At the end, the target destination starts a timer as soon as it gets the first RREQ packet. This allows to wait a certain moment to have the maximum of RREQs, which correspond to existing paths to the *vehicle1*. The waiting time is set to 50ms, in which all nodes do not change their positions a lot. These modifications of positions are considered as a minor variation according to their limited speeds in urban areas. However, beyond that time all received RREQs will be dropped and the broadcast is considered to be achieved. In this case, the destination *gateway5* has to take a routing decision by selecting the suitable path for data delivery.

Routing Table (Zone Z)				
Prev. Zone	Next Zone	Dest. ID/Zone	Flooding ID	Flooding SN
V	V	A	01	B
V	V	A	01	L
U	V	A	01	O
X	V	A	01	W
...

Figure 6.8: Routing table of the destination *gateway5*.

After the reception of the RREQs, a set of updates has to be done in the routing table of the target destination (*c.f.*, Figure 6.8), which can help for the knowledge of all existing routing paths. The destination node adds all received *SNs*, compares the calculated scores, selects the best path with the highest score, and updates the next zone in the routing table. The selected *SN* (*i.e.*, selected path), *PE*, *DisZone*, and the identifiers of the source and destination are included in the RREP and sent back to the source. These fields can be used both to make the reverse path and later in the maintenance phase.

Both UAVs and vehicles can constitute the routing paths to the target destination. However, the number of paths can be increased at crucial points such as intersections and UAVs, where a forwarder node has many possibilities to broadcast the RREQ to different next zones. The importance of UAVs, as well as intersections, is increasing the number of alternative solutions. These next zones are used when the network becomes sparsely connected.

6.5 Selection phase

The destination makes the selection phase only in the case where there are different discovered paths, in order to select the most suitable path for data delivery. A score is calculated by the destination for each discovered path based on several metrics already included in each received RREQ packet. Paths with low scores are undesirable because they are the most confronted with the problem of disconnection. Once a path obtains the best score, a Route Reply (RREP) packet is generated and sent back to the source node through this path. The RREP includes all necessary information about the selected path in order to be used later in the maintenance phase when a disconnection occurs.

6.5.1 Scoring calculation

In the example of Figure 6.5, several paths are received by the destination *gateway5* located in the zone *Z*. All necessary metrics of each path are described in TABLE 6.1. The calculation of the metrics related to the density such as σ , *Zone count*, μ , and $N(Z)$ are calculated based on the Online Algorithm [207] as follows:

- The value of σ is progressively calculated during the transition of the RREQ packet in each path. The Online algorithm allows to use only one field from the RREQ packet (*i.e.*, RREQ packet does not have a dynamic size to keep all values or store a full discovered path). The calculation has to be done using only one field (*i.e.*, the σ field) included in the RREQ packet.

- The value of *Zone count* is continuously incremented, while the RREQ packet is in transition at different zones in the path. The Increment is stopped by reaching the target destination.
- The total value of $N(Z)$ is progressively calculated at each transited zone, which also takes into account the density of nodes in the source and destination zones, respectively.

These metrics are calculated during the transition of the RREQ using the Online Algorithm [207] presented in Algorithm 7:

Algorithm 7: Online Algorithm

```

1  $Path_i$ : the current path;
2  $\sigma$ : the standard deviation;
3 Zone count: number of transited zones;
4 mean: additional variable;
5  $\mu$ : average number of nodes per zone;
6  $N(Z)$ : total number of nodes in the path;
7  $N(Z_i)$ : number of nodes in the zone  $i$ ;
8 Zone count  $\leftarrow 0$ ;
9 mean  $\leftarrow 0$ ;
10  $N(Z)$   $\leftarrow 0$ ;
11  $\sigma$   $\leftarrow 0$ ;
12 foreach  $N(Z_i) \in Path_i$  do
13   Zone count  $\leftarrow$  Zone count + 1;
14   variable1  $\leftarrow N(Z_i) - \textit{mean}$ ;
15   mean  $\leftarrow \textit{mean} + \left(\frac{\textit{variable1}}{\textit{Zone count}}\right)$ ;
16   variable2  $\leftarrow N(Z_i) - \textit{mean}$ ;
17    $\sigma$   $\leftarrow \sigma + (\textit{variable1} \times \textit{variable2})$ ;
18    $N(Z)$   $\leftarrow N(Z) + N(Z_i)$ ;
19  $\sigma$   $\leftarrow \sqrt{\sigma}$ ;
20  $\mu$   $\leftarrow \frac{N(Z)}{\textit{Zone count}}$ ;

```

To define the appropriate path among the discovered paths, we first need to calculate a *Score* for each discovered $Path_i$ based on the information included in the received RREQs. The destination D has the knowledge of accurate metrics of four paths (see TABLE 6.1). These crucial parameters represent the degree of the path robustness. The higher value of the *Score* means the better robustness of the path. For the sake of clarity, we calculate the different metrics (*i.e.*, μ and σ) directly from TABLE 6.1, which combining the final *Score*. The average number of nodes per zone (μ) is calculated as follows:

$$\mu = \frac{N(Z)}{\textit{Zone count}} \quad (6.2)$$

Table 6.1: Discovered paths.

<i>Path</i> ₁		<i>Path</i> ₂		<i>Path</i> ₃		<i>Path</i> ₄	
Zone count = 14		Zone count = 6		Zone count = 12		Zone count = 16	
N(Z) = 19		N(Z) = 7		N(Z) = 15		N(Z) = 20	
σ = 0.47		σ = 0.37		σ = 0.42		σ = 0.43	
Delay = 2(s)		Delay = 0.5(s)		Delay = 2.5(s)		Delay = 3(s)	
PE = 5(s)		PE = 1.5(s)		PE = 4(s)		PE = 4.5(s)	
DisZone = I		DisZone = M		DisZone = W		DisZone = P	
SN = B		SN = L		SN = W		SN = P	
Zone	Number of nodes	Zone	Number of nodes	Zone	Number of nodes	Zone	Number of nodes
A	1	A	1	A	1	A	1
B	2	L	1	B	2	B	2
C	1	M	1	C	1	C	1
D	1	N	1	D	1	D	1
E	1	V	2	E	1	E	1
F	2	Z	1	F	2	F	2
G	2			G	2	G	2
H	1			H	1	H	1
I	1			O	1	O	1
J	1			W	1	P	1
K	2			X	1	Q	1
N	1			Z	1	R	1
V	2					S	2
Z	1					T	1
						U	1
						Z	1
Score =25.85		Score =15.32		Score =10.56		Score =13.98	

Where *Zone count* is the total number of fixed zones within a specific discovered *Path*_{*i*} (e.g., in TABLE 6.1, the number of zones in *Path*₁ is equal to 14). N(Z) is the total number of nodes in the *Path*_{*i*}. The formal equation of the standard deviation of zone densities σ can be presented as follows:

$$\sigma = \sqrt{\frac{1}{Zone\ count} \times \sum_{i=1}^{Zone\ count} (N(Z_i) - \mu)^2} \quad (6.3)$$

Where $N(Z_i)$ defines the number of nodes present at a specific zone Z_i . A high standard deviation means that the nodes are widely dispersed around the average and vice versa. A disconnection can be caused if we obtain a small standard deviation, which corresponds to the unfair distribution of nodes at a specific *Path*_{*i*}.

If we take into consideration all intercepted information and the aforementioned calculated metrics, we can define a multi-criteria score for each *Path*_{*i*} based on the

following equation:

$$Score = \left\lfloor \frac{PE}{Delay} \right\rfloor \times \left(\frac{N(Z)}{1 + \sigma} \right) \quad (6.4)$$

From the equation (6.4), we can notice the following remarks:

- The calculated *Score* has a proportional relationship with $N(Z)$ and PE , which play a key role to determine the connectivity degree of a path.
- The floor of $\frac{PE}{Delay}$ represents if the corresponding path still remains connected or not during a data transmission. When $\left\lfloor \frac{PE}{Delay} \right\rfloor = 0$ it means that there is a high probability of disconnection during the data delivery. However, if $\left\lfloor \frac{PE}{Delay} \right\rfloor > 0$ it means that we have a certain guarantee that this path remains connected during the data transmission.
- Paths with high scores are suitable because they can ensure a reliable data delivery.

When the destination D selects the appropriate path (*e.g.*, $Path_1$ in Figure 6.5 and in TABLE 6.1), a Route Reply (RREP) packet is generated and sent back to the source S using the technique of greedy forwarding along the selected path (succession of zones).

6.5.2 The route reply (RREP) packet format

As shown in Figure 6.9, the RREP packet format consists of several fields. Certain fields are the same included in the RREQ packet such as the identifiers and the geographic positions of the source and destination. The SN field determines the selected path discovered beforehand, which is used for data delivery. The expiration time of the selected path PE and eventually its disconnection zone $DisZone$, which are exploited during the maintenance phase to determine an alternative path when the selected path will be disconnected during the data transmission.

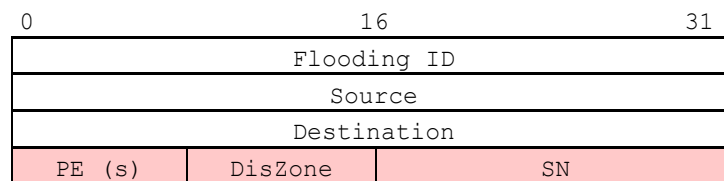

Figure 6.9: Route Reply (RREP) Format.

When the target destination calculates the suitable path for data delivery, it generates a RREP packet which will be sent back to the source. This packet contains all required information in order that the data packet can make the reverse path to the destination, and that, even if the selected path will be disconnected at a certain moment. As an illustration, we always take the example of Figure 6.5 to describe the series of modifications brought to the routing tables (*c.f.*, Figure 6.10).

Since the *gateway5* located in the zone Z has carried out the selection phase by choosing $Path_1$ as the most suitable path for data delivery. It starts sending unicastly the RREP packet to the next zone V , which belongs to $Path_1$. At each zone transited by the RREP packet, the modification has to be done in the routing tables of vehicles located in these zones. For example, in the zone N , the forwarder vehicle modifies its routing table according to the information included in the RREP packet.

Routing Table (Zone N)				
Prev. Zone	Next Zone	Dest. ID/Zone	Flooding ID	Flooding SN
K	V	Z	01	B
M	V	Z	01	L
V	K	A	01	B
...

(a) Routing table maintained at the zone N.

Routing Table (Zone H)				
Prev. Zone	Next Zone	Dest. ID/Zone	Flooding ID	Flooding SN
G	I	Z	01	B
G	O	Z	01	O
I	G	A	01	B
...

(b) Routing table maintained at the zone H.

Routing Table (Zone C)				
Prev. Zone	Next Zone	Dest. ID/Zone	Flooding ID	Flooding SN
B	D	Z	01	B
D	B	A	01	B
...

(c) Routing table maintained at the zone C.

Figure 6.10: Routing tables in crucial points during the selection phase.

A new routing entry is added, which contains the *Flooding ID*, the zones of both the source and target destination, and the next zone defined based on *SN* field included in the RREP. *SN* is equal to *B*, which means that the next zone is *K*, where the RREP is then forwarded to it (*c.f.*, Figure 6.10(a)). The same process is done in each transited zone, such as in the zone *H* and *C* (*See* Figure 6.10(b) and 6.10(c), respectively), where the same entry is added to the routing tables of vehicles located in these transited zones. These updates clearly indicate the right path for data packets to the target destination during the data delivery.

The RREP packet will be handled by all nodes in each transited zone of the selected path as shown in Algorithm 8:

Algorithm 8: RREP handling

```

1 C ← The current node;
2 Store (SNs of discovered paths);
3 // Include all SNs of paths discovered beforehand into the RREP
  packet.
4 if Destination (RREP) = C then
5   | Start Data packet delivering;
6   | // If I am the source of this RREP, I start sending the data
  packet.
7 else
8   | Greedy Forwarding (RREP, Selectedpath, Source);
9   | // If I am not the destination of this RREP, I will use the
  greedy forwarding along the selected path toward the
  destination (i.e., source of the request).

```

At the reception of the RREP packet by the source node located in the zone *A*, the source node is able to start the data delivery to the destination through the same selected path transited by the RREP packet (*c.f.*, Figure 6.5). For each data transmission, the data packet has to transit along each zone of the selected path in order to have a possibility to find an alternative solution at each hop if a next zone will be disconnected. Before starting the data delivery phase, the source node has to do some modification in its routing table by adding the new entry of the selected path (*c.f.*, Figure 6.11). This will help to start the data transmission and to send other data packets in the future if the selected path is not expired. Over 10 (s) of inactivity, each routing table is purged, and the discovery phase is a mandatory condition to make other data transmissions.

Routing Table (Zone A)				
Prev. Zone	Next Zone	Dest. ID/Zone	Flooding ID	Flooding SN
-	B	Z	01	B
-	L	Z	01	L
-	B	Z	01	B
...

Figure 6.11: Routing table of the source node at the selection phase.

6.6 Data delivery phase

The data delivery phase is carried out using the greedy forwarding technique when it is possible. This helps to minimize the number of hops, and consequently, the delay of delivering. If this path will be disconnected at a certain time, a maintenance technique is used to recover the path in order to avoid re-initializing the discovery phase. An essential condition for delivering data packets is receiving the RREP packet by the source node. Once all information included in the RREP packet is copied into the header of the data packet, the source node starts the data delivery phase using the technique of greedy forwarding along the selected path already transited by the RREP packet.

The header of the data packet consists of several fields similar to the RREP packet, which do not exceed 12 bytes (*c.f.*, Figure 6.12). The *Source* and *Destination* fields are used for both greedy forwarding technique and to indicate the sender and the receiver. *SN* field denotes the selected path, which has to be transited during the data delivery. *PE* and *DisZone* fields are periodically checked by the source vehicle and intermediate nodes in order to determine whether this selected path is still valid to make other data transmissions or to find other alternative solutions in the case of a sudden disconnection.

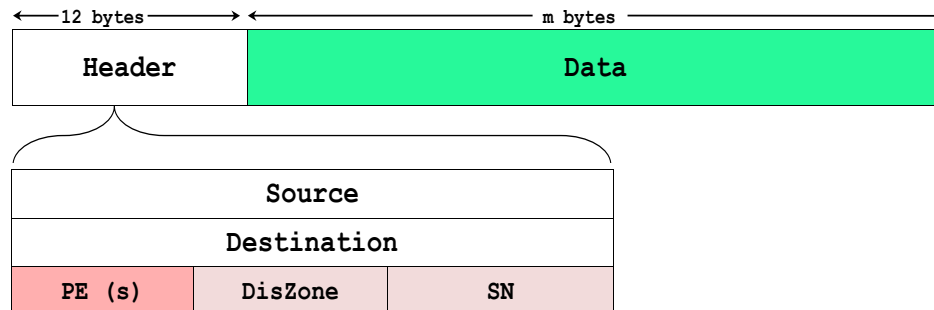

Figure 6.12: Data packet Format.

To illustrate the data delivery phase, we also take the example of Figure 6.5. The source *vehicle1* located in the zone *A* starts the data delivery to the *gateway5* located in the zone *Z*. For instance, when a vehicle located in the zone *C* receives the data packet, it checks its header and compares all information with those included in its updated routing table (*c.f.*, Figure 6.10(c)). Based on the *Destination*, *Flooding ID* and *SN* fields, the forwarder vehicle can find out automatically the next zone to the target destination.

The same maneuver is executed by the forwarder located in the zone *H*. Indeed, the zone *H* has two next zones *O* and *I*, where the forwarder selects the next zone *I* to forward the data packet to the destination. This can be done based on both *Flooding SN* and the modification carried out when the RREP packet doing the reverse path (*i.e.*, the new entry highlighted in red in the Figure 6.10(b)). When the data packet reaches the vehicle located in the zone *N*, its routing table is checked. As a result, to reach the target destination, two different routing entries are found leading to the same zone *V*, where the data packet is automatically forwarded to it.

When the destination node receives the data packet, it checks the *Destination* field in its header to confirm the reception of the data packet. In the case where the received data packet is not intended for this destination node, the current node checks its routing table to find the right next zone where the data packet will be forwarded.

The data packet will be handled by all nodes located at the selected path as shown in Algorithm 9:

Algorithm 9: Data packet handling

```

1 C ← The current node;
2 Store (Discovered paths);
3 // Include all paths discovered beforehand into the data packet.
4 if Destination (data) = C then
5   | Received packet (Success);
6   | // If I am the destination of this data packet, the data
   | transmission is carried out successfully.
7 else
8   | Greedy Forwarding (Data, Selectedpath, Destination);
9   | // If I am not the source of this data packet, I will use the
   | greedy forwarding along the selected path toward the
   | destination.

```

6.7 Maintenance phase

The maintenance phase takes place in the case when the selected path disconnects at a certain time. The current vehicle has the knowledge of the target destination's

location and its corresponding zone, which allows to use the greedy forwarding for data transmission. In a general case, if a next zone is disconnected in a selected path, the current node has to check its neighboring nodes to find the closest one to the destination. This is carried out based on the information included in the header of the data packet and its knowledge of the whole map (*i.e.*, the knowledge of each zone ID). If there is no connected zone in its neighboring zones, the vehicle has to generate a route error (RERR) packet. The RERR is sent back to the source in order to re-initiate the discovery phase if there are future transmissions.

Periodically, the forwarder node has to check a possible disconnection at the previous zone of *DisZone* in each transited path. This verification is beneficial to detect a possible disconnection. It is done through its table of neighbors to know whether there is a node located in *DisZone* or not, in order to avoid the packet losses and to forward the data packet to the right zone.

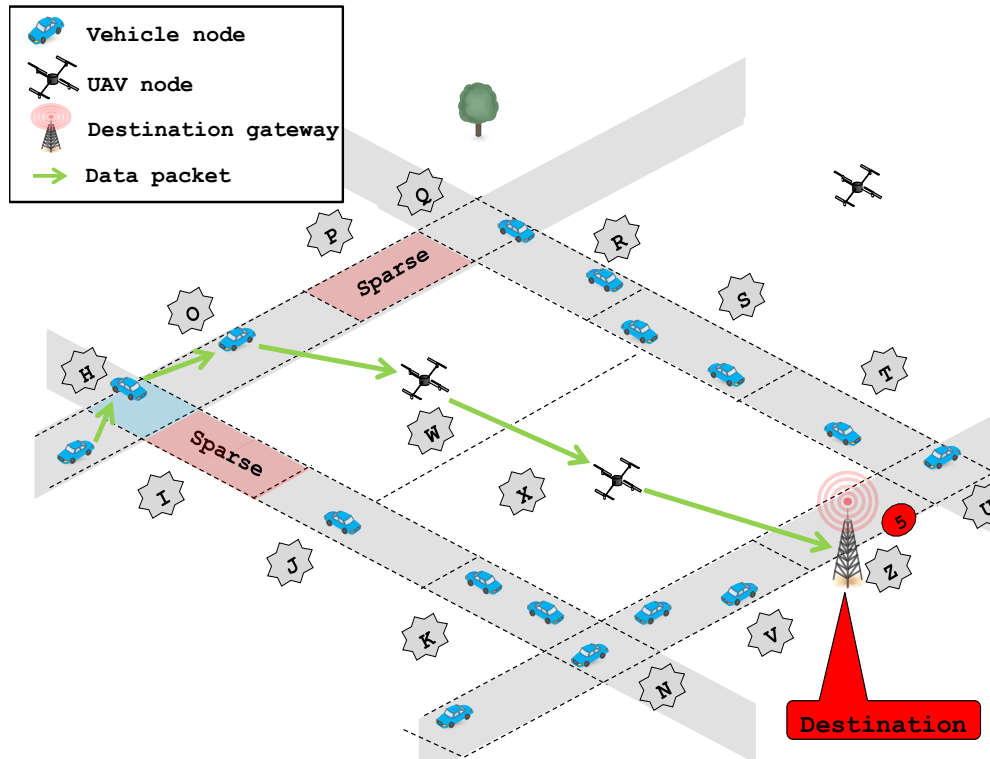

Figure 6.13: Recovered path failure.

To give a deeper understanding of the maintenance phase, we give a concrete example depicted in the Figure 6.13 by zooming in Figure 6.5. If, for example, the selected $Path_1$ is disconnected at the zone I and P . The closest node to the destination located in the zone Z has to be found to continue the data transmission. The current forwarder (*i.e.*, the forwarder located in the zone H) has to check the availability (connectivity) of next connected zones other than I and P . After verification (checking its routing table and intercepted Hello packets from the neighboring zones), the current vehicle finds the zone O as an alternative zone belonging to the $Path_3$

and $Path_4$. Known for its closer geographic location to the destination, the zone O can have a direct path to the destination. The data packet is forwarded to the zone O using the greedy forwarding technique until it gets the target destination.

In another scenario (*c.f.*, Figure 6.14), where the $Path_1$ and $Path_3$ disconnect at the zones I and W , respectively. The current vehicle located in the zone H checks its routing table to find an alternative solution. The zone O is found as a next connected zone where the data packet is automatically forwarded using the greedy forwarding. When the vehicle located in the zone O intercepts the data packet, it finds only that the zone P is connected and much closer to D . A vehicle located in the zone P is selected as the next hop, and so on until the data packet reaches the target destination.

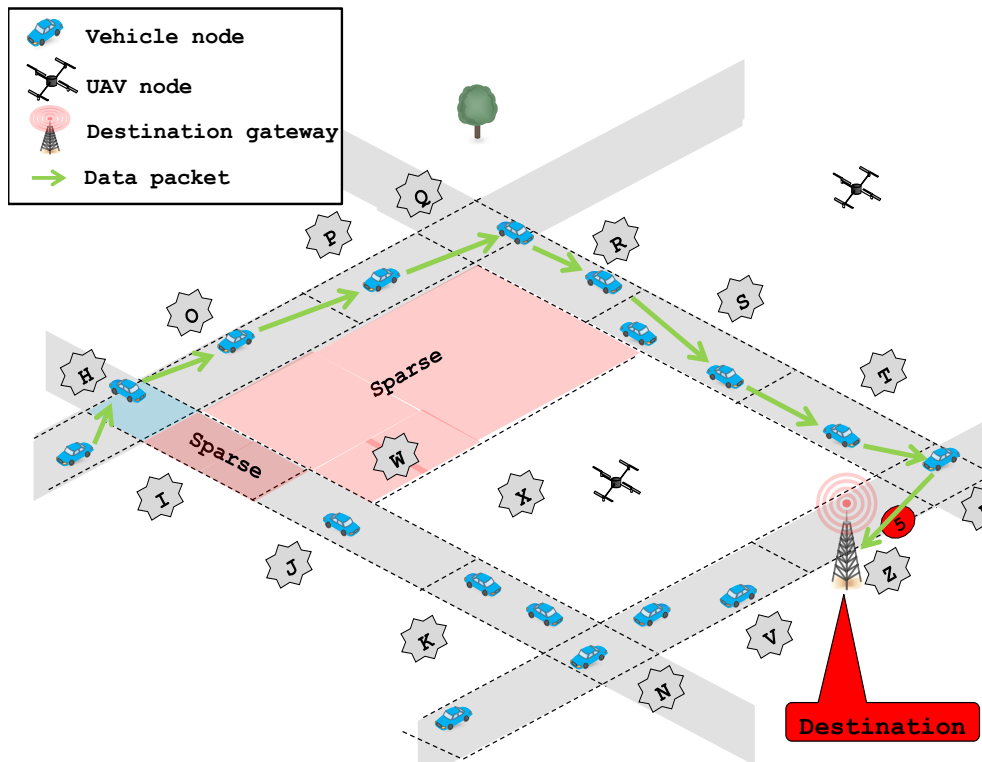

Figure 6.14: Another Recovered path failure.

According to several tests, the alternative connected zones can be found both in the sky and on the ground through UAVs and vehicles, respectively. The mechanism used during the maintenance phase can reduce significantly the overhead caused by the flooding of control packets. In addition, the packet losses and the end-to-end delay are also reduced due to the minimization of the discovery phase at each path failure.

6.8 Evaluation

To evaluate the performances of our protocol we use the simulation tool NS-2 [203]. Realistic movements are generated for both vehicles and UAVs, using two mobility generator tools SUMO [208] and MobiSim [197] respectively. These movements are based on a real-world urban area in Laghouat (Algeria) as shown in Figure 6.15, which knows a flexible and perpetual movement of vehicles. For the UAVs, a Random Walk mobility is deployed for up to 10 UAVs, which cover the simulated area. The geodata is imported from OpenStreetMap [209] in order to include the road layout in our simulation. This urban map is stretched over $4 \times 4 \text{ km}^2$ encompassing nearly 47 intersections, which are compounds of traffic lights and their period is set to 40 (s). All simulations are carried out under the parameters presented in TABLE 6.2. We suppose that the altitude of all UAVs does not exceed 200 meters during the flight. A number of evaluation metrics are calculated during the simulation such as the packet delivery ratio (PDR), the end-to-end delay (EED), the overhead (OH), and the average number of hops (HOP).

Table 6.2: Simulation parameters.

Simulation scenario		Routing	
Parameter	Range of values	Parameter	Range of values
Simulation area	4000m \times 4000m	Communication range of vehicles	$\approx 300\text{m}$
Simulation time	900s	Communication range of UAVs	$\approx 300\text{m}$
Mobility generator	SUMO [208]	MAC Protocol	IEEE 802.11p
Number of intersection	47	Frequency Band	5.9 GHz
Number of roads	100	Number of packets senders	50
Number of vehicles	80-320	Packet size	1 KB
Number of UAVs	0-10	Channel capacity	1Mbps
Vehicle speed	0-50 km/h	% of nodes requesting data	20 %
UAV speed	0-60 km/h	Evaluation metrics	PDR/EED/OH/HOP

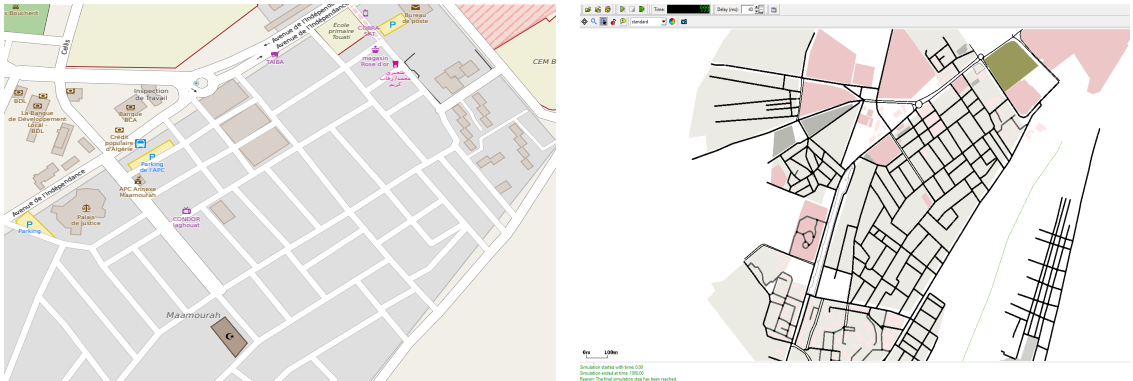

Figure 6.15: Map of the simulated area in Laghouat, Algeria (N 33°47' 51.5" E 2°51' 58.9").

6.8.1 Results analysis

The performances of our approach are compared with our previous protocols CRUV [8] and UVAR [10], in which their architectures resemble more closely to that employed by our approach. In addition, we also compare the performance of our approach with RBVT-R [151] and OLSR [146].

In order to prove again the efficiency of our approach, fifty pairs of mobile nodes are selected randomly to establish a communication between each other. This can also demonstrate that our approach supports mobile destinations. Moreover, to be more accurate in our simulations, the Hello interval is set to 0.1 (s). The list of neighboring nodes and routing tables included in all nodes are purged after 10 (s) of no activity. It is worthy to mention that the transmission ranges of vehicles and UAVs are considered as the same ($\approx 300\text{m}$). In addition, wireless channel interfaces are assumed to be integrated into both vehicles and UAVs.

80% is the probability of success for radio transmissions between UAVs. For the hybrid radio transmission (*between* UAVs and vehicles), the probability of success is set to 70%. The line of sight (LoS) is considered to be guaranteed between vehicles and UAVs, which allows establishing a radio transmission if they are in range of each other. However, no line of sight between vehicles on the ground if they are located in road segments not opposite from each other.

To evaluate the simulated protocols in a more realistic way, the initial geographic positions of both vehicles and UAVs are distributed fairly over the network. The mobility of UAVs and vehicles is controlled since their movements are limited only in the simulated area.

6.8.2 Packet delivery ratio (PDR)

As a first step, we evaluate the packet delivery ratio (PDR) under different densities of vehicles and UAVs for all the evaluated protocols. The results showed in Figure 6.16(a) and box plots in Figure 6.16(b), depict the proportionality of PDR with the density of vehicles for all the evaluated protocols. In the majority of cases, we clearly distinguish that our approach achieves a high delivery ratio compared with other protocols (more than 80%), which can be justified by the mechanism of prediction applied for the calculation of the path expiration PE . This permits to guarantee a safe data delivery to the target destination. Also, this mechanism can ensure a certain reliability of the discovered paths during their maintenance by minimizing the packet losses. We also notice the higher delivery ratios of RBVT-R and OLSR compared with those of UVAR and CRUV. Firstly, because RBVT-R is a reactive-based protocol working without using a penalizing technique such as the carry-and-forward which is employed by UVAR and CRUV. Secondly, because in OLSR, all routes are computed beforehand and data packets can be quickly forwarded or dropped at intermediate

nodes.

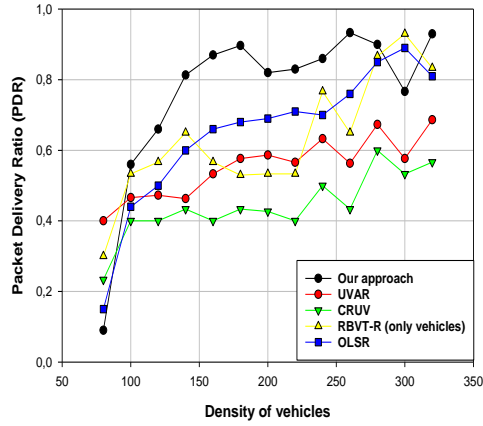

(a) PDR vs. Density of vehicles (UAVs=10).

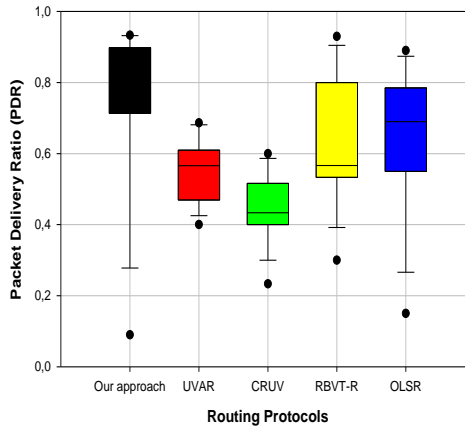

(b) Average packet delivery ratio.

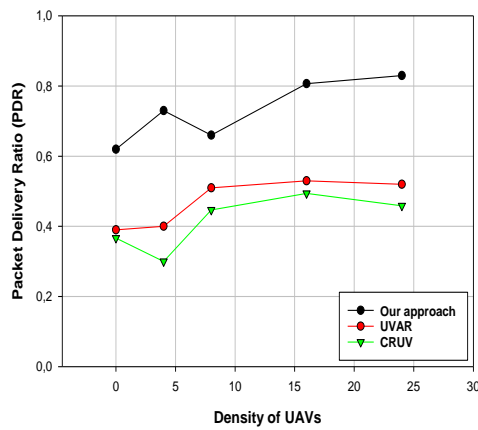

(c) PDR vs. Density of UAVs (Vehicles=200).

Figure 6.16: Packet Delivery Ratio vs. Density of nodes (Vehicles/UAVs).

Figure 6.16(c) shows the variation of PDR according to the density of UAVs for the UAV-Assisted routing protocols (*i.e.*, Our approach, UVAR, and CRUV). Our approach achieved the highest PDR which proves again its efficiency. This is because in the data delivery relies both on vehicles and UAVs (*i.e.*, paths can be composed of both vehicles and UAVs), which can ensure, at each time, possible paths in the sky or on the ground. However, for the other protocols, they rarely rely on UAVs to deliver data packets if the network on the ground is considered as a highly dense. It is the case in the simulated scenario where the number of vehicles is two hundred, which can be considered as a medium density.

6.8.3 End-to-End delay (EED)

As a second step, we analyze the impact of density of vehicles on the performance in terms of end-to-end delay depicted in Figure 6.17(a) and in the box plots in Figure 6.17(b). In general, we notice that our approach achieves the lowest delay for all vehicle densities. This is explained by the low durations taken during the discovery phase and the expiration time of paths calculated before the data delivery, which allows to avoid the re-initialization of the discovery phase at each path failure. However, RBVT-R does not perform as well as our approach, thus, it can be explained by the permanent re-initialization of the discovery phase at each broken path. This is essentially due to its inefficient maintenance mechanism compared with the prediction technique employed by our approach. In the reactive protocols, the flooding process, as well as the selection phase, can probably generate additional extra times. Nevertheless, it is not the case of OLSR, as a proactive protocol, the routes are maintained periodically by exchanging link state information among the nodes. This can cause a significant delay since it is not adapted to highly dynamic networks such as VANETs.

Several other causes of additional delays are observed during the simulation. For instance, in the delay tolerant network routing protocols such as UVAR and CRUV, the store-carry and forward is automatically used when the network is poorly dense generating an important additional delay. The data packets are transmitted using exclusively the physical movement of vehicles. However, their performances will be quickly recovered as the network becomes progressively connected.

Figure 6.17(c) shows the effect of changing the UAV density on the end-to-end delay of the UAV-assisted routing protocols. Our approach obtains the best results compared with other protocols. This is essentially due to the efficient discovery phase, which involves vehicles and UAVs as well. However, it is not the case of CRUV and UVAR, which use UAVs only for data delivery in certain cases, and in the majority of cases as central points in the selection phases (collectors). In addition, their excessive use of the store-carry and forward technique can be also a disadvantageous factor increasing the delay.

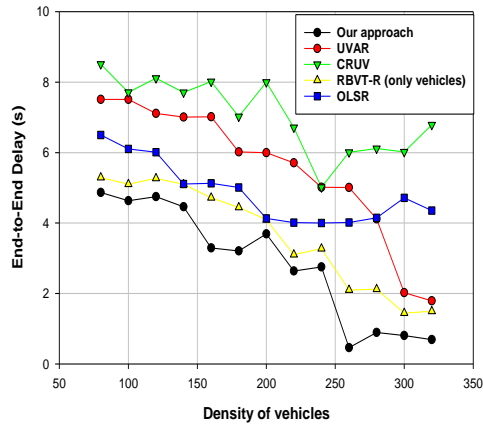

(a) EED vs. Density of vehicles (UAVs=10).

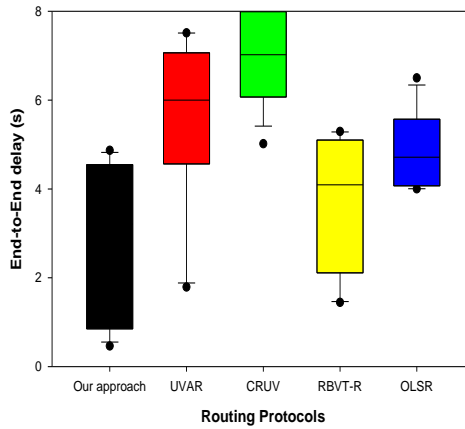

(b) Average EED.

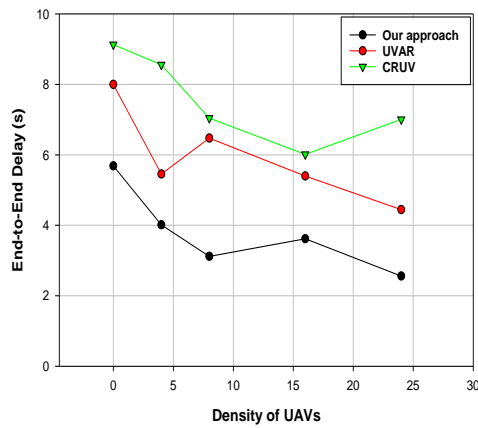

(c) EED vs. Density of UAVs (Vehicles=200).

Figure 6.17: End-to-End Delay vs. Density of nodes (Vehicles/UAVs).

6.8.4 Overhead (OH)

The curves and box plots presented in Figure 6.18(a) and Figure 6.18(b) respectively, show the overhead in each density variation. It can be shown that the control overhead of the reactive protocols (Our approach and RBVT-R) and the proactive protocol OLSR is important compared with CRUV or UVAR. This is mainly due to the generated control packets during the discovery phase and the periodical exchange of link states between the nodes respectively. However, as a reactive protocol, our approach has the lowest overhead, which it generates less overhead packets thanks to the used maintenance mechanism based on the prediction of the paths expiration. This allows minimizing the re-initialization of the discovery phase at each path failure. In addition, the used control packets in our approach have a fixed size, which also minimizes significantly the overhead over the network. However, it is not the case of RBVT-R and OLSR. As for UVAR and CRUV, they generate less overhead packets because they do not use any additional control packets except exchanging periodically the Hello packets between the nodes.

In figure 6.18(c), the results show clearly that our approach generates more overhead packets than UVAR and CRUV, which is mainly due to the extra generated control packets (RREQ, RREP, and RERR). The more the number of UAVs, the more will be the number of generated control packets during the flooding process. However, for UVAR and CRUV, they do not have any relationship with the additional UAVs in the network, since the UAVs are used only as traffic density information collectors and rarely as relays. Consequently, their control overheads are very low and stay approximately constant during all the simulations. UVAR has more control overhead than CRUV, which is explained by the important exchange of Hello packets between UAVs and all vehicles. However, it is not the case of CRUV, in which Hello packets are only exchanged between UAVs and vehicles located at the intersections in order to calculate the scores of each road segment. Furthermore, in CRUV, the UAVs do not play a key role in the selection of the road segments.

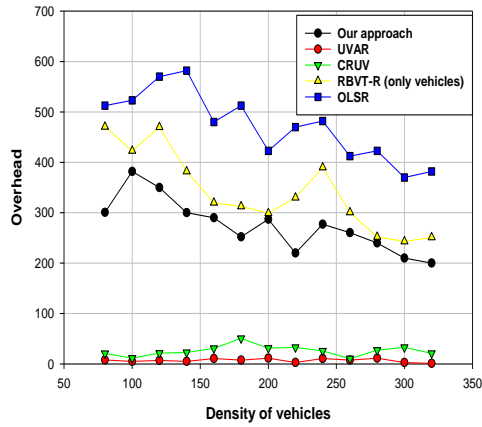

(a) OH vs. Density of vehicles (UAVs=10).

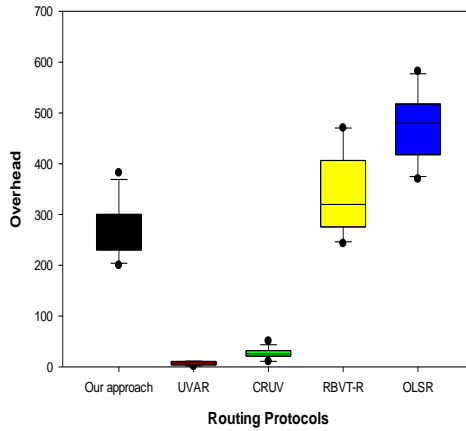

(b) Average overhead.

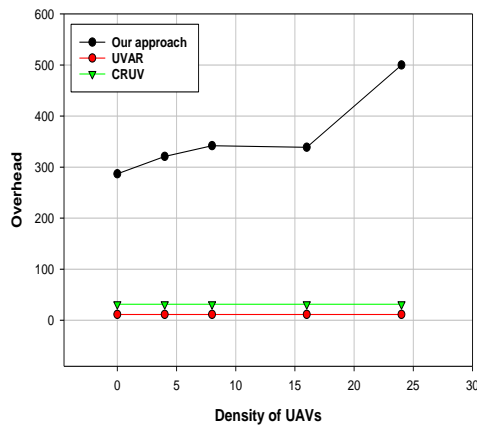

(c) OH vs. Density of UAVs (Vehicles=200).

Figure 6.18: Control Overhead vs. Density of nodes (Vehicles/UAVs).

6.8.5 Average number of hops (HOP)

Figure 6.19(a) and Figure 6.19(b) show the average number of hops according to the vehicle density for the evaluated protocols. It is clearly observed that the average number of hops of UVAR and CRUV has a proportional relationship with the density of vehicles. This is essentially caused by two factors: (i) the long distances between the communicating nodes, and (ii) the selection of the densest road segments and at a certain time without taking into consideration the distances separating each pair of communicating nodes. However, for the reactive protocols (our approach and RBVT-R), initially (low densities 80-180) they have an important number of hops compared with UVAR and CRUV, which is essentially due to the frequent failures caused by the high mobility of nodes. This imposes to the reactive protocols to re-initiate the discovery phase for each data request increasing at each time the number of hops for a requested data packet. In a general case, we can approximately say that the number of hops has a stable behavior except for the higher densities (240-320). In our approach, we distinguished a slight decrease of hops caused by the use of the greedy forwarding technique and especially through UAVs, which minimizes considerably the number of hops. The same observation is distinguished for RBVT-R, where the number of hops decreases for the higher densities. However, due to occasional disconnections on the network, RBVT-R can re-initialize the discovery phase. As for OLSR, we clearly distinguish a high average number of hops in most of the cases, which is explained by the hop-by-hop transition of the data packets.

Figure 6.19(c) shows that the average number of hops of our approach is significantly higher than CRUV and UVAR for 8, 16, and 24 UAVs. This is because when the number of UAVs increases, the paths which are composed of both vehicles and UAVs will be increased, and consequently, the number of hops will increase. However, for UVAR and CRUV, the number of hops decreases as the number of UAVs is increased, which is mainly due to the increase of the UAVs coverage in the simulated area. This can facilitate the frequent use of vehicles and UAVs for data delivery, which minimizes significantly the number of hops.

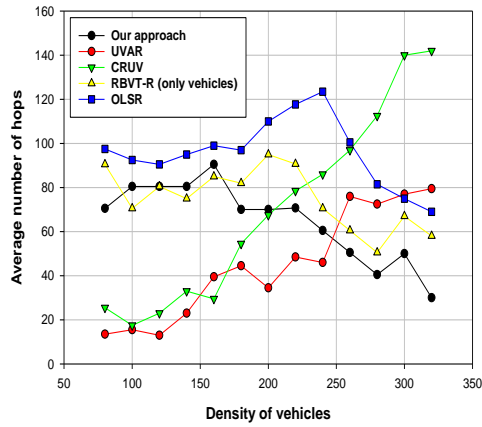

(a) HOP vs. Density of vehicles (UAVs=10).

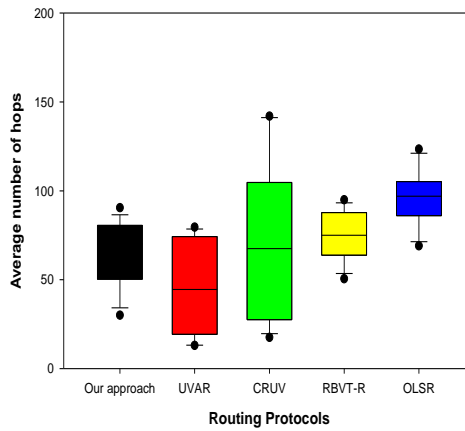

(b) Average number of hops.

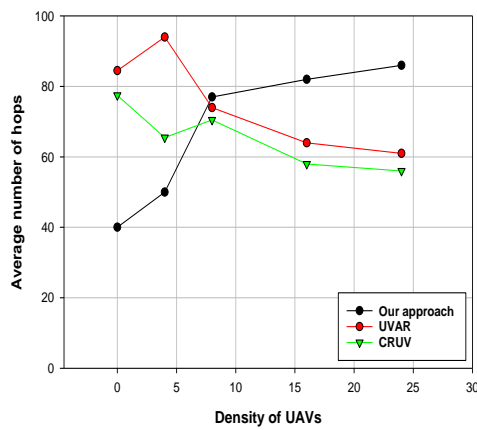

(c) HOP vs. Density of UAVs (Vehicles=200).

Figure 6.19: Average number of hops vs. Density of nodes (Vehicles/UAVs).

6.9 Conclusion

In this *chapter*, a novel reactive routing protocol has been introduced. This scheme exploits a multi-criteria selection of paths which allows benefiting from the advantages of well-stable and regulated paths toward fixed or mobile nodes. Several applications requiring a minimum of packet losses can be supported by this routing scheme. Working in conjunction with the flooding process, a predictive technique is also used by our approach in order to estimate accurately the expiration time of paths at each discovery phase initialized by a requesting node. In addition to vehicles, UAVs are dispersed in the sky in which can also belong to the discovered paths, and consequently, participate in the data delivery and act as relays. Also, UAVs have demonstrated their crucial role in the majority of time during the maintenance phase due to their localizations, which allow vehicles to find an appropriate support at each time when a path is disconnected.

Performance results are presented, which clearly justify our claims for the use of this hybrid wireless communication between vehicles and UAVs in terms of delivery ratio and delay of transmission. We have noticed that the data delivery in our approach can be done in a near-optimal end-to-end delay with a minimum of overhead and smaller number of hops. However, it is not the case of the routing protocols proposed in the same category. Given such performances, another part of this work which we are currently investigating is the control of the UAV's mobility could become part of future work. This technique will be a keystone of the path failures detection by placing UAVs at adequate locations in order to be a bridge between two disconnected parts of the network. Furthermore, our protocol will be improved by including a security component and adapted to different environments such as rural and highways.

Chapter 7

Conclusion

Contents

7.1 Overview of the contribution	146
7.2 Limitations and possible improvements	148
7.3 Future directions	149

7.1 Overview of the contribution

VANETs are an emerging class of ad hoc networks, enabling data exchange between vehicles and between road infrastructure and vehicles. VANETs provide commuters a multitude of services, comfort applications, and contribute to the road safety and transportation efficiency. VANET services and applications require intensive communications between vehicles and critical information needs to be robustly and rapidly delivered to the drivers. Hence, the necessity to deploy an efficient routing technique in order to find a stable communication path in which data packets can be routed from one node to another with a maximum of reliability.

Two major problems are identified: (i) instability of routing paths and (ii) frequent network fragmentation due to the high mobility of nodes. Many of the routing protocols proposed in the literature aim to relay the data packets reliably with a minimum delay taking into account the environments where they are deployed. However, using traditional V2V communications alone appears to be insufficient in fragmented networks. In this context, we proposed a novel approach that integrates the use of UAVs with vehicles for improving data routing in VANETs, and making routing paths more robust and more stable. Following this same vision, we proposed a set of routing protocols dedicated for VANETs with the assistance of UAVs to make the routing process more efficient and reliable. Our routing protocols not only complement each other, but also together provide an ability to face network fragmentation and frequent disconnections when they occur, and provide better routes to ad hoc data.

In this research, we conducted several experiments that show the benefits of our routing protocols. The obtained results demonstrate the effectiveness and the reliability of our routing protocols to deal with the aforementioned problems, and validate their feasibility in a real-world scenarios. In the following, we give an overview of the contributions presented in this thesis:

- Given the nature of the UAANETs compared to VANETs, and given the mobility models employed by UAVs, we first presented the different techniques adopted during the data exchange in UAANETs and VANETs. In this context, we have provided a comprehensive survey of the UAANETs routing protocols proposed in the literature and conceived to deal with the different limitations and drawbacks distinguished in each kind of networks [210]. Also, we have classified these protocols into different categories based on the followed technique during the data delivery. Comparative studies are proposed to highlight the weaknesses and the open issues in each kind of routing protocols.
- Our first routing proposal is called CRUV, which is based on UAVs as relays assisting the data exchange between vehicles on the ground and participating in the routing process [8]. The idea behind this routing protocol is to have a global knowledge of the connected road segments located elsewhere from the vehicle making a forwarding decision. This knowledge helps to make a reliable routing and to ensure a robust data delivery until the receivers, increasing considerably the delivery ratio of data packets. However, when the network suffers from fragmentations, UAVs here can be used as relays instead of vehicles. Therefore, the end-to-end delay and the number of hops are decreased significantly, because using UAVs as relays can considerably reduce the distance transited by data packets. It is worthy to note the steady increase in overhead generated by the periodical exchange of Hello packets between UAVs and vehicles.
- CRUV does not consider the connectivity degree as a criteria to select the road segments and does not fully exploit UAVs. Our second proposal called UVAR is based on two routing components working with completely different strategies called UVAR-S and UVAR-G [9, 10]. UVAR-S operates in the sky and fully exploits UAVs to deliver data packets between a pair of source and destination nodes, while avoiding disconnections and obstructions on the ground. As for UVAR-G, data packets are routed on the ground through vehicles with the assistance of UAVs to select the well-regulated and most connected road segments for data delivery. As simulation results, UVAR-G achieved a high delivery ratio and a low and stable delay due to the accurate calculations provided by existing UAVs and shared with vehicles on the ground. In addition, the combination of the greedy forwarding technique and the efficient selection of the road segments permit to decrease the distance traveled by the data packets, and consequently, decreasing both the delay of delivery and the number of hops. As for UVAR-S, the data packets are delivered in the sky through UAVs using a reactive technique. In contrast with UVAR-G, in UVAR-S we have the full path to the

target destinations, increasing considerably the delivery ratio of data packets, with a significant delay of transition, and important overhead due to the control packets used during the flooding process.

- A unified reactive routing strategy is used by our final contribution called UAV-Assisted reactive routing for urban VANETs [11]. Indeed, as indicated by its name, this approach uses a reactive strategy to build on-demand robust routing paths to the target destinations. The discovered paths can be composed of vehicles and UAVs providing efficient support during the recovery phase. The destination has the possibility to receive many discovered routing paths from the source, which can be all exploited as alternative solutions in the case of disconnections. The maintenance process has proven its efficiency by improving the delay of transmission and the delivery ratio of data packets. Nevertheless, an important overhead is distinguished during the discovery process or in the case when there is no connectivity among the nodes.

7.2 Limitations and possible improvements

CRUV, UVAR, and our UAV-Assisted reactive protocol provided interesting performance results, and showed many advantages especially in the case of frequent disconnections and in network configurations with fragmentation. Nevertheless, these techniques can show some limitations and therefore call for improvement.

- In the case of CRUV, a vehicle making a routing decision relies on the selection of the most connected segments either detected by itself or detected by UAVs. Since the connectivity degree is a neglected factor on the segments constituting the routing path, a necessary improvement will be to take into account the real distribution of vehicles to estimate accurately this factor on the selected road segments. In addition, we suggest making UAVs the only place where routing decisions are made instead of the vehicles, because of their general view of the overflowed area.
- In UVAR, a routing decision is based on two calculated scores, $Score_G$ and $Score_S$. According to the highest score, data packets can be delivered exclusively in the sky or on the ground. Since the network topology is continuously changing, a major improvement would be to incorporate a adaptive method during which data delivery is made according to the network situation. For instance, data packets can be forwarded through UAVs in the sky; however, when the vehicles on the ground are more connected than UAVs, data transits through vehicles on the ground.
- The performance of our reactive-based protocol is based on experiments lacking some realistic elements like obstacles in urban environments such as buildings, etc.. Therefore, this technique can be further improved by adapting it to a

more realistic scenarios. As a next-step research, we intend to incorporate obstructions in our simulation model that will allow us to study the reactivity of our approach in the presence of obstructions and obstacles. In addition, another improvement to this technique is to investigate ways to further reduce the overhead and improve the reception rate of data packets.

A plenty of robust and adaptive methods have tried to address the problems encountered in a variety of routing categories in VANETs. However, all these methods showed drawbacks when it comes to react to certain abnormalities about the data delivery and to adapt to perturbations of the node's mobility. The integration of data routing in both UAANETs and VANETs opens the door to more research that can improve data routing in the next generation intelligent transportation systems. Our believe is that our contribution in this thesis represents one of the first steps in a more heterogeneous ad hoc networks.

7.3 Future directions

The inter-vehicle communication is apparently a complex task to be achieved. This task becomes more complex than expected when it is both deployed in urban areas and supported by existing UAVs in the sky. As a result, several future research directions open up as follows:

- Investigating and analyzing various mobility models of UAVs for various UAV applications and services.
- Extending UAV-assisted routing schemes for VANETs with new schemes adapted to uncontrolled environments.
- Incorporating security features into our routing schemes.
- Extending and deploying our routing solutions in environments other than urban areas, such as highways and rural areas.

Bibliography

- [1] I. . W. Group *et al.*, “Ieee standard for information technology-telecommunications and information exchange between systems-local and metropolitan area networks-specific requirements part 11: Wireless lan medium access control (mac) and physical layer (phy) specifications,” *IEEE Std*, vol. 802, no. 11, 2010.
- [2] H. Jiang, H. Guo, and L. Chen, “Reliable and efficient alarm message routing in vanet,” in *Proceeding of the 28th International Conference on Distributed Computing Systems Workshops (ICDCS’08)*. IEEE, 2008, pp. 186–191.
- [3] A. Ghazal, C.-X. Wang, B. Ai, D. Yuan, and H. Haas, “A nonstationary wide-band mimo channel model for high-mobility intelligent transportation systems,” *IEEE Transactions on Intelligent Transportation Systems*, vol. 16, no. 2, pp. 885–897, 2015.
- [4] W. Chen, R. K. Guha, T. J. Kwon, J. Lee, and Y.-Y. Hsu, “A survey and challenges in routing and data dissemination in vehicular ad hoc networks,” *Wireless Communications and Mobile Computing*, vol. 11, no. 7, pp. 787–795, 2011.
- [5] K. Z. Ghafoor, M. A. Mohammed, J. Lloret, K. A. Bakar, and Z. M. Zainuddin, “Routing protocols in vehicular ad hoc networks: survey and research challenges,” *Network Protocols and Algorithms*, vol. 5, no. 4, pp. 39–83, 2013.
- [6] J. Harri, F. Filali, and C. Bonnet, “Mobility models for vehicular ad hoc networks: a survey and taxonomy,” *IEEE Communications Surveys & Tutorials*, vol. 11, no. 4, 2009.
- [7] T. L. Willke, P. Tientrakool, and N. F. Maxemchuk, “A survey of inter-vehicle communication protocols and their applications,” *IEEE Communications Surveys & Tutorials*, vol. 11, no. 2, 2009.
- [8] O. S. Oubbati, A. Lakas, N. Lagraa, and M. B. Yagoubi, “CRUV: Connectivity-based traffic density aware routing using UAVs for VANETs,” in *Proceedings of the IEEE International Conference on Connected Vehicles and Expo (ICCVE)*, 2015.

- [9] O. S. Oubbati, A. Lakas, F. Zhou, M. Güneş, N. Lagraa, and M. B. Yagoubi, “Intelligent UAV-Assisted Routing Protocol for Urban VANETs,” *Computer communications*, vol. 107, pp. 93–111, 2017.
- [10] O. S. Oubbati, A. Lakas, N. Lagraa, and M. B. Yagoubi, “UVAR: An intersection UAV-Assisted VANET routing protocol,” in *Proceedings of the IEEE Wireless Communications and Networking Conference (WCNC)*, 2016.
- [11] O. S. Oubbati, A. Lakas, F. Zhou, M. Güneş, and M. B. Yagoubi, “UAV-assisted reactive routing for urban VANETs,” in *Proceedings of the 32nd ACM SIGAPP Symposium On Applied Computing (SAC)*, 2017, pp. 1–3.
- [12] C. E. Perkins *et al.*, *Ad hoc networking*. Addison-wesley Reading, 2001, vol. 1.
- [13] C. S. R. Murthy and B. Manoj, *Ad hoc wireless networks: Architectures and protocols, portable documents*. Pearson education, 2004.
- [14] H. Li, M. Lott, M. Weckerle, W. Zirwas, and E. Schulz, “Multihop communications in future mobile radio networks,” in *Personal, Indoor and Mobile Radio Communications, 2002. The 13th IEEE International Symposium on*, vol. 1. IEEE, 2002, pp. 54–58.
- [15] Z. Zhang, “Routing in intermittently connected mobile ad hoc networks and delay tolerant networks: overview and challenges,” *IEEE Communications Surveys & Tutorials*, vol. 8, no. 1, pp. 24–37, 2006.
- [16] M. Dipobagio, “An overview on ad hoc networks,” *Institute of Computer Science (ICS), Freie Universitat Berlin*, 2008.
- [17] S. Toumpis and D. Toumpakaris, “Wireless ad hoc networks and related topologies: applications and research challenges,” *e & i Elektrotechnik und Informationstechnik*, vol. 123, no. 6, pp. 232–241, 2006.
- [18] S. K. Sarkar, T. Basavaraju, and C. Puttamadappa, *Ad hoc mobile wireless networks: principles, protocols and applications*. CRC Press, 2007.
- [19] Y.-C. Tseng, S.-Y. Ni, Y.-S. Chen, and J.-P. Sheu, “The broadcast storm problem in a mobile ad hoc network,” *Wireless networks*, vol. 8, no. 2/3, pp. 153–167, 2002.
- [20] M. Abolhasan, T. Wysocki, and E. Dutkiewicz, “A review of routing protocols for mobile ad hoc networks,” *Ad hoc networks*, vol. 2, no. 1, pp. 1–22, 2004.
- [21] L. Bao and J. J. Garcia-Luna-Aceves, “Topology management in ad hoc networks,” in *Proceedings of the 4th ACM international symposium on Mobile ad hoc networking & computing*. ACM, 2003, pp. 129–140.
- [22] J. Cartigny, F. Ingelrest, D. Simplot-Ryl, and I. Stojmenović, “Localized lms and rng based minimum-energy broadcast protocols in ad hoc networks,” *Ad Hoc Networks*, vol. 3, no. 1, pp. 1–16, 2005.

- [23] A. E. Gamal, J. Mammen, B. Prabhakar, and D. Shah, “Throughput-delay trade-off in wireless networks,” in *INFOCOM 2004. Twenty-third Annual Joint Conference of the IEEE Computer and Communications Societies*, vol. 1. IEEE, 2004.
- [24] Y. Ganjali and A. Keshavarzian, “Load balancing in ad hoc networks: single-path routing vs. multi-path routing,” in *INFOCOM 2004. Twenty-third Annual Joint Conference of the IEEE Computer and Communications Societies*, vol. 2. IEEE, 2004, pp. 1120–1125.
- [25] R. Negi and A. Rajeswaran, “Capacity of power constrained ad-hoc networks,” in *INFOCOM 2004. Twenty-third Annual Joint Conference of the IEEE Computer and Communications Societies*, vol. 1. IEEE, 2004.
- [26] C.-K. Toh, “Maximum battery life routing to support ubiquitous mobile computing in wireless ad hoc networks,” *IEEE communications Magazine*, vol. 39, no. 6, pp. 138–147, 2001.
- [27] M. Bisignano, A. Calvagna, G. D. Modica, and O. Tomarchio, “Expeerience: a jxta middleware for mobile ad-hoc networks,” in *Peer-to-Peer Computing, 2003. (P2P 2003). Proceedings. Third International Conference on.* IEEE, 2003, pp. 214–215.
- [28] M. Burmester, T. Van Le, and A. Yasinsac, “Adaptive gossip protocols: Managing security and redundancy in dense ad hoc networks,” *Ad Hoc Networks*, vol. 5, no. 3, pp. 313–323, 2007.
- [29] D. Subhadrabandhu, S. Sarkar, and A. Farooq, “A statistical framework for intrusion detection in ad hoc networks,” 2006.
- [30] M. Conti and S. Giordano, “Mobile ad hoc networking: milestones, challenges, and new research directions,” *IEEE Communications Magazine*, vol. 52, no. 1, pp. 85–96, 2014.
- [31] M. Güneş, B. Blywis, and F. Juraschek, “Concept and design of the hybrid distributed embedded systems testbed,” 2008.
- [32] X. M. Zhang, Y. Zhang, F. Yan, and A. V. Vasilakos, “Interference-based topology control algorithm for delay-constrained mobile ad hoc networks,” *IEEE Transactions on Mobile Computing*, vol. 14, no. 4, pp. 742–754, 2015.
- [33] N. Raza, M. U. Aftab, M. Q. Akbar, O. Ashraf, and M. Irfan, “Mobile ad-hoc networks applications and its challenges,” *Communications and Network*, vol. 8, no. 03, p. 131, 2016.
- [34] P. Goyal, V. Parmar, and R. Rishi, “Manet: vulnerabilities, challenges, attacks, application,” *IJCEM International Journal of Computational Engineering & Management*, vol. 11, no. 2011, pp. 32–37, 2011.

- [35] W. Kiess, J. Rybicki, and M. Mauve, “On the nature of inter-vehicle communication,” in *Communication in Distributed Systems (KiVS), 2007 ITG-GI Conference*. VDE, 2007, pp. 1–10.
- [36] J. Luo and J.-P. Hubaux, “A survey of inter-vehicle communication,” Tech. Rep., 2004.
- [37] B. K. Chaurasia, R. S. Tomar, S. Verma, and G. S. Tomar, “Suitability of manet routing protocols for vehicular ad hoc networks,” in *Communication Systems and Network Technologies (CSNT), 2012 International Conference on*. IEEE, 2012, pp. 334–338.
- [38] E. Spaho, M. Ikeda, L. Barolli, F. Xhafa, M. Younas, and M. Takizawa, “Performance evaluation of olsr and aodv protocols in a vanet crossroad scenario,” in *Advanced Information Networking and Applications (AINA), 2013 IEEE 27th International Conference on*. IEEE, 2013, pp. 577–582.
- [39] A. Mahajan, N. Potnis, K. Gopalan, and A. Wang, “Urban mobility models for vanets,” in *2nd IEEE International Workshop on Next Generation Wireless Networks*, vol. 33, 2006.
- [40] T. Kosch, C. J. Adler, S. Eichler, C. Schroth, and M. Strassberger, “The scalability problem of vehicular ad hoc networks and how to solve it,” *IEEE Wireless Communications*, vol. 13, no. 5, 2006.
- [41] D. Pareit, B. Lannoo, I. Moerman, and P. Demeester, “The history of wimax: A complete survey of the evolution in certification and standardization for ieee 802.16 and wimax.” *IEEE Communications Surveys and Tutorials*, vol. 14, no. 4, pp. 1183–1211, 2012.
- [42] I. S. Association *et al.*, “802.11-2012-ieee standard for information technology–telecommunications and information exchange between systems local and metropolitan area networks–specific requirements part 11: Wireless lan medium access control (mac) and physical layer (phy) specifications,” *IEEE Std*, vol. 802, 2012.
- [43] X. Lagrange, P. Godlewski, S. Tabbane, and R. GSM, “des principesa la norme, editions hermes sciences,” ISBN 2-7462-0153-4, Tech. Rep., 2000.
- [44] I. C. S. L. M. S. Committee *et al.*, “Wireless lan medium access control (mac) and physical layer (phy) specifications,” *IEEE Standard 802.11-1997*, 1997.
- [45] W. Viriyasitavat, O. K. Tonguz, and F. Bai, “Network connectivity of vanets in urban areas,” in *Sensor, Mesh and Ad Hoc Communications and Networks, 2009. SECON'09. 6th Annual IEEE Communications Society Conference on*. IEEE, 2009, pp. 1–9.

- [46] S. Yousefi, E. Altman, and R. El-Azouzi, “Study of connectivity in vehicular ad hoc networks,” in *Modeling and Optimization in Mobile, Ad Hoc and Wireless Networks and Workshops, 2007. WiOpt 2007. 5th International Symposium on*. IEEE, 2007, pp. 1–6.
- [47] M. S. Al-Kahtani, “Survey on security attacks in vehicular ad hoc networks (vanets),” in *Signal Processing and Communication Systems (ICSPCS), 2012 6th International Conference on*. IEEE, 2012, pp. 1–9.
- [48] K. Mershad and H. Artail, “A framework for secure and efficient data acquisition in vehicular ad hoc networks,” *IEEE Transactions on vehicular technology*, vol. 62, no. 2, pp. 536–551, 2013.
- [49] W. Kiess, J. Rybicki, and M. Mauve, “On the nature of inter-vehicle communication,” in *Communication in Distributed Systems (KiVS), 2007 ITG-GI Conference*. VDE, 2007, pp. 1–10.
- [50] J. Luo and J.-P. Hubaux, “A survey of inter-vehicle communication,” Tech. Rep., 2004.
- [51] Y. Toor, P. Muhlethaler, and A. Laouiti, “Vehicle ad hoc networks: Applications and related technical issues,” *IEEE communications surveys & tutorials*, vol. 10, no. 3, 2008.
- [52] H. ALshaer and E. Horlait, “An optimized adaptive broadcast scheme for inter-vehicle communication,” in *Vehicular Technology Conference, 2005. VTC 2005-Spring. 2005 IEEE 61st*, vol. 5. IEEE, 2005, pp. 2840–2844.
- [53] R. Mangharam, R. Rajkumar, M. Hamilton, P. Mudaliget, and F. Bait, “Bounded-latency alerts in vehicular networks,” in *2007 Mobile Networking for Vehicular Environments*. IEEE, 2007, pp. 55–60.
- [54] J.-F. Lee, C.-S. Wang, and M.-C. Chuang, “Fast and reliable emergency message dissemination mechanism in vehicular ad hoc networks,” in *Wireless Communications and Networking Conference (WCNC), 2010 IEEE*. IEEE, 2010, pp. 1–6.
- [55] Y. Zhuang, J. Pan, Y. Luo, and L. Cai, “Time and location-critical emergency message dissemination for vehicular ad-hoc networks,” *IEEE Journal on Selected Areas in Communications*, vol. 29, no. 1, pp. 187–196, 2011.
- [56] T. ETSI, “Intelligent transport systems (its); vehicular communications; basic set of applications; definitions,” Tech. Rep. ETSI TR 102 638, Tech. Rep., 2009.
- [57] C. V. S. C. Consortium *et al.*, “Vehicle safety communications project: Task 3 final report: identify intelligent vehicle safety applications enabled by dsrc,” *National Highway Traffic Safety Administration, US Department of Transportation, Washington DC*, 2005.

- [58] D. Ni, J. Li, S. Andrews, and H. Wang, “Preliminary estimate of highway capacity benefit attainable with intelligidrive technologies,” in *Intelligent Transportation Systems (ITSC), 2010 13th International IEEE Conference on*. IEEE, 2010, pp. 819–824.
- [59] Y. Liu and U. Ozguner, “Effect of inter-vehicle communication on rear-end collision avoidance,” in *Intelligent Vehicles Symposium, 2003. Proceedings. IEEE*. IEEE, 2003, pp. 168–173.
- [60] R. Tatchikou, S. Biswas, and F. Dion, “Cooperative vehicle collision avoidance using inter-vehicle packet forwarding,” in *Global Telecommunications Conference, 2005. GLOBECOM’05. IEEE*, vol. 5. IEEE, 2005, pp. 5–pp.
- [61] P. Seiler, A. Pant, and K. Hedrick, “Disturbance propagation in vehicle strings,” *IEEE Transactions on automatic control*, vol. 49, no. 10, pp. 1835–1842, 2004.
- [62] L. Li and F.-Y. Wang, “Cooperative driving at blind crossings using intervehicle communication,” *IEEE Transactions on Vehicular Technology*, vol. 55, no. 6, pp. 1712–1724, 2006.
- [63] L. Wischhof, A. Ebner, and H. Rohling, “Information dissemination in self-organizing intervehicle networks,” *IEEE Transactions on intelligent transportation systems*, vol. 6, no. 1, pp. 90–101, 2005.
- [64] T. Delot, N. Cenerario, S. Ilarri, and S. Lecomte, “A cooperative reservation protocol for parking spaces in vehicular ad hoc networks,” in *Proceedings of the 6th International Conference on Mobile Technology, Application & Systems*. ACM, 2009, p. 30.
- [65] T. Kitani, T. Shinkawa, N. Shibata, K. Yasumoto, M. Ito, and T. Higashino, “Efficient vanet-based traffic information sharing using buses on regular routes,” in *Vehicular Technology Conference, 2008. VTC Spring 2008. IEEE*. IEEE, 2008, pp. 3031–3036.
- [66] S.-B. Lee, J.-S. Park, M. Gerla, and S. Lu, “Secure incentives for commercial ad dissemination in vehicular networks,” *IEEE Transactions on Vehicular Technology*, vol. 61, no. 6, pp. 2715–2728, 2012.
- [67] H. Hartenstein and L. Laberteaux, “A tutorial survey on vehicular ad hoc networks,” *IEEE Communications magazine*, vol. 46, no. 6, 2008.
- [68] R. Kumar, M. Dave *et al.*, “A review of various vanet data dissemination protocols,” *International Journal of u-and e-Service, Science and Technology*, vol. 5, no. 3, pp. 27–44, 2012.
- [69] F. D. Da Cunha, A. Boukerche, L. Villas, A. C. Viana, and A. A. Loureiro, “Data communication in vanets: a survey, challenges and applications,” Ph.D. dissertation, INRIA Saclay; INRIA, 2014.

- [70] P. Fazio, F. De Rango, C. Sottile, and C. Calafate, “A new channel assignment scheme for interference-aware routing in vehicular networks,” in *Vehicular Technology Conference (VTC Spring), 2011 IEEE 73rd*. IEEE, 2011, pp. 1–5.
- [71] M. Torrent-Moreno, D. Jiang, and H. Hartenstein, “Broadcast reception rates and effects of priority access in 802.11-based vehicular ad-hoc networks,” in *Proceedings of the 1st ACM international workshop on Vehicular ad hoc networks*. ACM, 2004, pp. 10–18.
- [72] J. H. Howard, M. L. Kazar, S. G. Menees, D. A. Nichols, M. Satyanarayanan, R. N. Sidebotham, and M. J. West, “Scale and performance in a distributed file system,” *ACM Transactions on Computer Systems (TOCS)*, vol. 6, no. 1, pp. 51–81, 1988.
- [73] X. Lin, R. Lu, C. Zhang, H. Zhu, P.-H. Ho, and X. Shen, “Security in vehicular ad hoc networks,” *IEEE communications magazine*, vol. 46, no. 4, 2008.
- [74] I. Broustis and M. Faloutsos, “Routing in vehicular networks: feasibility, modeling, and security,” *International Journal of Vehicular Technology*, vol. 2008, 2008.
- [75] S. Rosati, K. Kruźelecki, G. Heitz, D. Floreano, and B. Rimoldi, “Dynamic routing for flying ad hoc networks,” *IEEE Transactions on Vehicular Technology*, vol. 65, no. 3, pp. 1690–1700, 2016.
- [76] M. Moorkamp, J.-L. Wybo, and E.-H. Kramer, “Pioneering with uavs at the battlefield: The influence of organizational design on self-organization and the emergence of safety,” *Safety science*, vol. 88, pp. 251–260, 2016.
- [77] I. Maza, F. Caballero, J. Capitán, J. R. Martínez-de Dios, and A. Ollero, “Experimental results in multi-uav coordination for disaster management and civil security applications,” *Journal of intelligent & robotic systems*, vol. 61, no. 1, pp. 563–585, 2011.
- [78] C. Barrado, R. Messeguer, J. López, E. Pastor, E. Santamaria, and P. Royo, “Wildfire monitoring using a mixed air-ground mobile network,” *IEEE Pervasive Computing*, vol. 9, no. 4, pp. 24–32, 2010.
- [79] X. Meng, W. Wang, and B. Leong, “Skystitch: a cooperative multi-uav-based real-time video surveillance system with stitching,” in *Proceedings of the 23rd ACM international conference on Multimedia*. ACM, 2015, pp. 261–270.
- [80] Z. Sun, P. Wang, M. C. Vuran, M. A. Al-Rodhaan, A. M. Al-Dhelaan, and I. F. Akyildiz, “Bordersense: Border patrol through advanced wireless sensor networks,” *Ad Hoc Networks*, vol. 9, no. 3, pp. 468–477, 2011.
- [81] S. Rathinam, P. Almeida, Z. Kim, S. Jackson, A. Tinka, W. Grossman, and R. Sengupta, “Autonomous searching and tracking of a river using an uav,” in *American Control Conference, 2007. ACC’07*. IEEE, 2007, pp. 359–364.

- [82] R. R. Pitre, X. R. Li, and R. Delbalzo, “Uav route planning for joint search and track missions—an information-value approach,” *IEEE Transactions on Aerospace and Electronic Systems*, vol. 48, no. 3, pp. 2551–2565, 2012.
- [83] C. C. Murray and W. Park, “Incorporating human factor considerations in unmanned aerial vehicle routing,” *IEEE Transactions on Systems, Man, and Cybernetics: Systems*, vol. 43, no. 4, pp. 860–874, 2013.
- [84] S. A. Vollgger and A. R. Cruden, “Mapping folds and fractures in basement and cover rocks using uav photogrammetry, cape liptrap and cape paterson, victoria, australia,” *Journal of Structural Geology*, vol. 85, pp. 168–187, 2016.
- [85] J. Cho, G. Lim, T. Biobaku, S. Kim, and H. Parsaei, “Safety and security management with unmanned aerial vehicle (UAV) in oil and gas industry,” *Procedia Manufacturing*, vol. 3, pp. 1343–1349, 2015.
- [86] L. Zaouche, E. Natalizio, and A. Bouabdallah, “ETTAF: Efficient target tracking and filming with a flying ad hoc network,” in *Proceedings of the 1st ACM International Workshop on Experiences with the Design and Implementation of Smart Objects*, 2015, pp. 49–54.
- [87] G. Danoy, M. R. Brust, and P. Bouvry, “Connectivity stability in autonomous multi-level UAV swarms for wide area monitoring,” in *Proceedings of the 5th ACM Symposium on Development and Analysis of Intelligent Vehicular Networks and Applications*, 2015, pp. 1–8.
- [88] Y. Ben-Asher, S. Feldman, P. Gurfil, and M. Feldman, “Distributed decision and control for cooperative UAVs using ad hoc communication,” *IEEE Transactions on Control Systems Technology*, vol. 16, no. 3, pp. 511–516, 2008.
- [89] O. K. Sahingoz, “Networking models in flying ad-hoc networks (FANETs): Concepts and challenges,” *Journal of Intelligent & Robotic Systems*, vol. 74, no. 1-2, pp. 513–527, 2014.
- [90] S. Cameron, S. Hailes, S. Julier, S. McClean, G. Parr, N. Trigoni, M. Ahmed, G. McPhillips, R. De Nardi, J. Nie *et al.*, “SUAAVE: Combining aerial robots and wireless networking,” in *Proceedings of the 25th Bristol International UAV Systems Conference*, 2010, pp. 1–14.
- [91] J. Clapper, J. Young, J. Cartwright, and J. Grimes, “Unmanned systems roadmap 2007-2032,” *Office of the Secretary of Defense*, p. 188, 2007.
- [92] N. M. Rodday, R. d. O. Schmidt, and A. Pras, “Exploring security vulnerabilities of unmanned aerial vehicles,” in *Network Operations and Management Symposium (NOMS), 2016 IEEE/IFIP*. IEEE, 2016, pp. 993–994.
- [93] B. D. Anderson, B. Fidan, C. Yu, and D. Walle, “UAV formation control: theory and application,” in *Recent advances in learning and control*. Springer, 2008, pp. 15–33.

- [94] P.-M. Olsson, J. Kvarnström, P. Doherty, O. Burdakov, and K. Holmberg, “Generating UAV communication networks for monitoring and surveillance,” in *Proceedings of the 11th IEEE International Conference on Control Automation Robotics & Vision (ICARCV)*, 2010, pp. 1070–1077.
- [95] J.-A. Maxa, G. Roudiere, and N. Larrieu, “Emulation-based performance evaluation of routing protocols for UAANETs,” in *Communication Technologies for Vehicles*. Springer, 2015, pp. 227–240.
- [96] I. Bekmezci, O. K. Sahingoz, and Ş. Temel, “Flying ad-hoc networks (FANETs): A survey,” *Ad Hoc Networks*, vol. 11, no. 3, pp. 1254–1270, 2013.
- [97] E. Yanmaz, C. Costanzo, C. Bettstetter, and W. Elmenreich, “A discrete stochastic process for coverage analysis of autonomous UAV networks,” in *Proceedings of the IEEE Globecom Workshops*, 2010, pp. 1777–1782.
- [98] D. Jung and P. Tsiotras, “Inertial attitude and position reference system development for a small UAV,” *AIAA Infotech at aerospace*, pp. 7–10, 2007.
- [99] G. Mao, S. Drake, and B. Anderson, “Design of an extended kalman filter for UAV localization,” in *Proceedings of IEEE Information, Decision and Control (IDC’07)*, 2007, pp. 224–229.
- [100] I. Maza, K. Kondak, M. Bernard, and A. Ollero, “Multi-UAV cooperation and control for load transportation and deployment,” *Journal of Intelligent and Robotic Systems*, vol. 57, no. 1-4, pp. 417–449, 2010.
- [101] H. Kurdi, J. How, and G. Bautista, “Bio-inspired algorithm for task allocation in Multi-UAV search and rescue missions,” in *Proceedings of the AIAA Guidance, Navigation, and Control Conference*, 2016, p. 1377.
- [102] P. F. Peng, L. Gong, and Q. Yu, “Research on architecture for Multi-UAV systems based on autonomous cooperation,” in *Proceeding of Applied Mechanics and Materials*, vol. 713. Trans Tech Publ, 2015, pp. 825–828.
- [103] M. M. Trujillo, K. Duling, M. Darrach, E. Fuller, and M. Wathen, “Fitness function changes to improve performance in a GA used for multi-UAV tasking,” in *Proceedings of the IEEE Workshop on Research, Education and Development of Unmanned Aerial Systems (RED-UAS)*, 2015, pp. 211–218.
- [104] S. Simi, R. Kurup, and S. Rao, “Distributed task allocation and coordination scheme for a multi-UAV sensor network,” in *Proceedings of the IEEE Tenth International Conference on Wireless and Optical Communications Networks (WOCN)*, 2013, pp. 1–5.
- [105] I. Bekmezci, M. Ermis, and S. Kaplan, “Connected multi UAV task planning for flying ad hoc networks,” in *Proceedings of the IEEE International Black Sea Conference on Communications and Networking (BlackSeaCom)*, 2014, pp. 28–32.

- [106] A. Suarez, G. Heredia, and A. Ollero, “Cooperative sensor fault recovery in multi-UAV systems,” in *Proceedings of the IEEE International Conference on Robotics and Automation (ICRA)*, 2016, pp. 1188–1193.
- [107] D. Zhou, H. Zhang, Q. Pan, and K. Zhang, “An improved range parameterized square root cubature information filter algorithm for multi-UAV cooperative passive location,” in *Proceedings of the IEEE International Conference on Information and Automation*, 2015, pp. 1079–1084.
- [108] H. Duan, Q. Luo, Y. Shi, and G. Ma, “Hybrid particle swarm optimization and genetic algorithm for Multi-UAV formation reconfiguration,” *IEEE Computational Intelligence Magazine*, vol. 8, no. 3, pp. 16–27, 2013.
- [109] J. Tang, L. Fan, and S. Lao, “Collision avoidance for Multi-UAV based on geometric optimization model in 3d airspace,” *Arabian Journal for Science and Engineering*, vol. 39, no. 11, pp. 8409–8416, 2014.
- [110] V. Sharma and R. Kumar, “A cooperative network framework for multi-UAV guided ground ad hoc networks,” *Journal of Intelligent & Robotic Systems*, vol. 77, no. 3-4, pp. 629–652, 2015.
- [111] B. Coifman, M. McCord, R. G. Mishalani, M. Iswalt, and Y. Ji, “Roadway traffic monitoring from an unmanned aerial vehicle,” in *Proceedings of the IEEE Proceedings-Intelligent Transport Systems*, vol. 153, no. 1. IET, 2006, pp. 11–20.
- [112] A. Puri, K. Valavanis, and M. Kontitsis, “Statistical profile generation for traffic monitoring using real-time UAV based video data,” in *Proceedings of the IEEE Mediterranean Conference on Control & Automation (MED’07)*, 2007, pp. 1–6.
- [113] A. S. Laliberte, J. E. Herrick, A. Rango, and C. Winters, “Acquisition, orthorectification, and object-based classification of unmanned aerial vehicle (UAV) imagery for rangeland monitoring,” *Photogrammetric Engineering & Remote Sensing*, vol. 76, no. 6, pp. 661–672, 2010.
- [114] S. Siebert and J. Teizer, “Mobile 3D mapping for surveying earthwork projects using an unmanned aerial vehicle (UAV) system,” *Automation in Construction*, vol. 41, pp. 1–14, 2014.
- [115] D. W. Casbeer, R. W. Beard, T. W. McLain, S.-M. Li, and R. K. Mehra, “Forest fire monitoring with multiple small UAVs,” in *Proceedings of the IEEE American Control Conference*, 2005, pp. 3530–3535.
- [116] E. P. de Freitas, T. Heimfarth, I. F. Netto, C. E. Lino, C. E. Pereira, A. M. Ferreira, F. R. Wagner, and T. Larsson, “UAV relay network to support wsn connectivity,” in *Proceedings of the IEEE International Congress on Ultra Modern Telecommunications and Control Systems and Workshops (ICUMT)*, 2010, pp. 309–314.

- [117] H. Y. Song, “A method of mobile base station placement for high altitude platform based network with geographical clustering of mobile ground nodes,” in *Proceedings of the IEEE International Multiconference on Computer Science and Information Technology (IMCSIT)*, 2008, pp. 869–876.
- [118] A. Sivakumar and C. K.-Y. Tan, “UAV swarm coordination using cooperative control for establishing a wireless communications backbone,” in *Proceedings of the 9th International Conference on Autonomous Agents and Multiagent Systems*. International Foundation for Autonomous Agents and Multiagent Systems, 2010, pp. 1157–1164.
- [119] Y. Zhou, N. Cheng, N. Lu, and X. S. Shen, “Multi-UAV-Aided networks: Aerial-ground cooperative vehicular networking architecture,” *IEEE Vehicular Technology Magazine*, vol. 10, no. 4, pp. 36–44, 2015.
- [120] R. M. Noor, R. H. Khokhar, R. Jabbarpour, S. Khorsandroo, N. Khamis, and O. Michael, “Using VANET to support green vehicle communications for urban operation rescue,” in *Proceedings of the 12th International IEEE Conference on ITS Telecommunications (ITST)*, 2012, pp. 324–328.
- [121] I. Rubin and R. Zhang, “Placement of UAVs as communication relays aiding mobile ad hoc wireless networks,” in *Proceedings of the Military Communications Conference (MILCOM)*, 2007, pp. 1–7.
- [122] O. I. Lysenko, I. V. Uriadnikova, S. V. Valuiskyi, S. M. Chumachenko, P. I. Kirchu, and A. I. Semenchenko, “Increasing of manet throughput using quasi-optimal UAVs placement control,” *Science & Military Journal*, vol. 8, no. 1, p. 24, 2013.
- [123] O. Burdakov, P. Doherty, K. Holmberg, and P.-M. Olsson, “Optimal placement of UV-based communications relay nodes,” *Journal of Global Optimization*, vol. 48, no. 4, pp. 511–531, 2010.
- [124] P. Basu, J. Redi, and V. Shurbanov, “Coordinated flocking of UAVs for improved connectivity of mobile ground nodes,” in *Proceedings of the Military Communications Conference (MILCOM)*, vol. 3, 2004, pp. 1628–1634.
- [125] J.-A. Maxa, M. S. B. Mahmoud, and N. Larrieu, “Secure routing protocol design for UAV ad hoc networks,” in *Proceedings of the 34th IEEE/AIAA Digital Avionics Systems Conference (DASC)*, 2015, pp. 1–4A5.
- [126] D. F. Pigatto, G. F. Roberto, L. Gonçalves, J. F. Rodrigues Filho, A. S. R. Pinto, and K. R. L. J. C. Branco, “HAMSTER-Healthy, mobility and security-based data communication architecture for unmanned aircraft systems,” in *Proceedings of the International Conference on Unmanned Aircraft Systems (ICUAS)*, 2014, pp. 52–63.

- [127] N. Michael, D. Mellinger, Q. Lindsey, and V. Kumar, “The grasp multiple Micro-UAV testbed,” *IEEE Robotics & Automation Magazine*, vol. 17, no. 3, pp. 56–65, 2010.
- [128] E. King, Y. Kuwata, M. Alighanbari, L. Bertuccelli, and J. How, “Coordination and control experiments on a multi-vehicle testbed,” in *Proceedings of the American Control Conference*, vol. 6, 2004, pp. 5315–5320.
- [129] T. W. McLain and R. W. Beard, “Unmanned air vehicle testbed for cooperative control experiments,” in *Proceedings of the American Control Conference*, vol. 6, 2004, pp. 5327–5331.
- [130] B. Coifman, M. McCord, M. Mishalani, and K. Redmill, “Surface transportation surveillance from unmanned aerial vehicles,” in *Proceedings of the 83rd Annual Meeting of the Transportation Research Board*, 2004.
- [131] S. Srinivasan, H. Latchman, J. Shea, T. Wong, and J. McNair, “Airborne traffic surveillance systems: video surveillance of highway traffic,” in *Proceedings of the 2nd international ACM workshop on Video surveillance & sensor networks*, 2004, pp. 131–135.
- [132] Y.-K. Jung, Y. Lee, and W.-S. Ra, “Optimal formation of cooperative multiple UAVs for enhancing passive target tracking performance,” in *Proceedings of the IEEE IECON 2016-42nd Annual Conference on Industrial Electronics Society*, 2016, pp. 1004–1009.
- [133] A. Hafez and S. Givigi, “Formation reconfiguration of cooperative UAVs via learning based model predictive control in an obstacle-loaded environment,” in *Proceedings of the IEEE Annual Systems Conference (SysCon)*, 2016, pp. 1–8.
- [134] A. T. Hafez and M. A. Kamel, “Fault-tolerant control for cooperative unmanned aerial vehicles formation via fuzzy logic,” in *Proceedings of the International Conference on Unmanned Aircraft Systems (ICUAS)*, 2016, pp. 1261–1266.
- [135] K. Li, W. Ni, X. Wang, R. P. Liu, S. S. Kanhere, and S. Jha, “Energy-efficient cooperative relaying for unmanned aerial vehicles,” *IEEE Transactions on Mobile Computing*, vol. 15, no. 6, pp. 1377–1386, 2016.
- [136] M. Alighanbari and J. How, “Robust decentralized task assignment for cooperative UAVs,” in *Proceedings of the AIAA Guidance, Navigation, and Control Conference and Exhibit*, 2006, p. 6454.
- [137] M. Lao and J. Tang, “Cooperative Multi-UAV collision avoidance based on distributed dynamic optimization and causal analysis,” *Applied Sciences*, vol. 7, no. 1, p. 83, 2017.
- [138] N. Rupasinghe, A. S. Ibrahim, and I. Guvenc, “Optimum hovering locations with angular domain user separation for cooperative UAV networks,” in *Proceedings of the Global Communications Conference (GLOBECOM)*, 2016, pp. 1–6.

- [139] S. M. Esmailifar and F. Saghafi, “Cooperative localization of marine targets by UAVs,” *Mechanical Systems and Signal Processing*, vol. 87, pp. 23–42, 2017.
- [140] F. Koochifar, A. Kumbhar, and I. Guvenc, “Receding horizon Multi-UAV cooperative tracking of moving RF source,” *IEEE Communications Letters*, 2016.
- [141] J. Li, G. Deng, C. Luo, Q. Lin, Q. Yan, and Z. Ming, “A hybrid path planning method in unmanned air/ground vehicle (UAV/UGV) cooperative systems,” *IEEE Transactions on Vehicular Technology*, vol. 65, no. 12, pp. 9585–9596, 2016.
- [142] A. Fonseca and T. Vazão, “Applicability of position-based routing for vanet in highways and urban environment,” *Journal of Network and Computer Applications*, vol. 36, no. 3, pp. 961–973, 2013.
- [143] J. Kakarla, S. S. Sathya, B. G. Laxmi *et al.*, “A survey on routing protocols and its issues in vanet,” 2011.
- [144] J. A. Davis, A. H. Fagg, and B. N. Levine, “Wearable computers as packet transport mechanisms in highly-partitioned ad-hoc networks,” in *Wearable Computers, 2001. Proceedings. Fifth International Symposium on.* IEEE, 2001, pp. 141–148.
- [145] G. Pei, M. Gerla, and T.-W. Chen, “Fisheye state routing: A routing scheme for ad hoc wireless networks,” in *Communications, 2000. ICC 2000. 2000 IEEE International Conference on*, vol. 1. IEEE, 2000, pp. 70–74.
- [146] T. Clausen and P. Jacquet, “Optimized link state routing protocol (OLSR),” Tech. Rep., 2003.
- [147] M. G. Lewis, R. G. Ogier, and F. L. Templin, “Topology dissemination based on reverse-path forwarding (tbrpf),” *Topology*, 2004.
- [148] D. Johnson, Y. Hu, and D. Maltz, “The dynamic source routing protocol (DSR) for mobile ad hoc networks for ipv4,” Tech. Rep., 2007.
- [149] C. Perkins, E. Belding-Royer, and S. Das, “Ad hoc on-demand distance vector (AODV) routing,” Tech. Rep., 2003.
- [150] M. Jiang, “Cluster based routing protocol (cbrp),” *draft-ietf-manet-cbrp-spec-01.txt*, 1999.
- [151] J. Nzouonta, N. Rajgure, G. Wang, and C. Borcea, “VANET routing on city roads using real-time vehicular traffic information,” *IEEE Transactions on Vehicular Technology*, vol. 58, no. 7, pp. 3609–3626, 2009.
- [152] Z. Mo, H. Zhu, K. Makki, and N. Pissinou, “Muru: A multi-hop routing protocol for urban vehicular ad hoc networks,” in *Mobile and Ubiquitous Systems: Networking & Services, 2006 Third Annual International Conference on.* IEEE, 2006, pp. 1–8.

- [153] S. Yan, X.-y. JIN, and S.-z. CHEN, “Agp: an anchor-geography based routing protocol with mobility prediction for vanet in city scenarios,” *The Journal of China Universities of Posts and Telecommunications*, vol. 18, pp. 112–117, 2011.
- [154] W. Sun, H. Yamaguchi, K. Yukimasa, and S. Kusumoto, “Gvgrid: A QoS routing protocol for vehicular ad hoc networks,” in *Proceedings of the 14th IEEE International Workshop on Quality of Service*, 2006, pp. 130–139.
- [155] C. Lochert, H. Hartenstein, J. Tian, H. Fussler, D. Hermann, and M. Mauve, “A routing strategy for vehicular ad hoc networks in city environments,” in *Proceedings of the IEEE Intelligent Vehicles Symposium (IV)*, 2003, pp. 156–161.
- [156] B.-C. Seet, G. Liu, B.-S. Lee, C.-H. Foh, K.-J. Wong, and K.-K. Lee, “A-STAR: A mobile ad hoc routing strategy for metropolis vehicular communications,” in *Proceedings of the Networking 2004*, Springer, 2004, pp. 989–999.
- [157] K. C. Lee, J. O. Häerri, U. Lee, and M. Gerl, “Enhanced perimeter routing for geographic forwarding protocols in urban vehicular scenarios,” in *Proceedings of the IEEE Globecom Workshops (GC Wkshps)*, 2007, pp. 1–10.
- [158] H. Saleet, R. Langar, K. Naik, R. Boutaba, A. Nayak, and N. Goel, “Intersection-based geographical routing protocol for VANETs: a proposal and analysis,” *IEEE Transactions on Vehicular Technology*, vol. 60, no. 9, pp. 4560–4574, 2011.
- [159] O. S. Oubbati, A. Lakas, N. Lagraa, and M. B. Yagoubi, “ETAR: Efficient traffic light aware routing protocol for vehicular networks,” in *Proceedings of the IEEE International Wireless Communications and Mobile Computing Conference (IWCMC)*, 2015, pp. 297–301.
- [160] M. Jerbi, S.-M. Senouci, T. Rasheed, and Y. Ghamri-Doudane, “Towards efficient geographic routing in urban vehicular networks,” *IEEE Transactions on Vehicular Technology*, vol. 58, no. 9, pp. 5048–5059, 2009.
- [161] K. Singh and A. K. Verma, “Experimental analysis of AODV, DSDV and OLSR routing protocol for flying ad hoc networks (FANETs),” in *Proceedings of the IEEE International Conference on Electrical, Computer and Communication Technologies (ICECCT)*, 2015, pp. 1–4.
- [162] K. Singh and A. K. Verma, “Applying olsr routing in FANETs,” in *Proceedings of the IEEE International Conference on Advanced Communication Control and Computing Technologies (ICACCCT)*, 2014, pp. 1212–1215.
- [163] D. S. Vasiliev, D. S. Meitis, and A. Abilov, “Simulation-based comparison of AODV, OLSR and HWMP protocols for flying ad hoc networks,” in *Proceedings of the International Conference on Next Generation Wired/Wireless Networking*. Springer, 2014, pp. 245–252.

- [164] A. I. Alshbatat and L. Dong, “Cross layer design for mobile ad-hoc unmanned aerial vehicle communication networks,” in *Proceedings of the IEEE International Conference on Networking, Sensing and Control (ICNSC)*, 2010, pp. 331–336.
- [165] A. B. Paul and S. Nandi, “Modified optimized link state routing (M-OLSR) for wireless mesh networks,” in *Proceedings of the IEEE International Conference on Information Technology (ICIT’08)*, 2008, pp. 147–152.
- [166] M. Belhassen, A. Belghith, and M. A. Abid, “Performance evaluation of a cartography enhanced OLSR for mobile multi-hop ad hoc networks,” in *Proceedings of IEEE Wireless Advanced (WiAd)*, 2011, pp. 149–155.
- [167] A. Aggarwal, S. Gandhi, N. Chaubey, P. Shah, and M. Sadhwani, “AODVSEC: A novel approach to secure ad hoc on-demand distance vector (AODV) routing protocol from insider attacks in MANETs,” *arXiv preprint arXiv:1208.1959*, 2012.
- [168] J. H. Forsmann, R. E. Hiromoto, and J. Svoboda, “A time-slotted on-demand routing protocol for mobile ad hoc unmanned vehicle systems,” in *Proceedings of the Defense and Security Symposium*. International Society for Optics and Photonics, 2007, pp. 1–11.
- [169] C. Perkins and E. Royer-Belding, “Multicast ad hoc on-demand distance vector (MAODV) routing,” IETF Internet Draft, draft-ietf-manet-maodv-00. txt (Work in Progress), Tech. Rep., 2000.
- [170] Y. Wei, M. B. Blake, and G. R. Madey, “An operation-time simulation framework for UAV swarm configuration and mission planning,” *Procedia Computer Science*, vol. 18, pp. 1949–1958, 2013.
- [171] Z. J. Haas and M. R. Pearlman, “ZRP: a hybrid framework for routing in ad hoc networks,” in *Proceedings of Ad hoc networking*. Addison-Wesley Longman Publishing Co., Inc., 2001, pp. 221–253.
- [172] V. Ramasubramanian, Z. J. Haas, and E. G. Sirer, “SHARP: A hybrid adaptive routing protocol for mobile ad hoc networks,” in *Proceedings of the 4th ACM international symposium on Mobile ad hoc networking & computing*. ACM, 2003, pp. 303–314.
- [173] G. Pei, M. Gerla, X. Hong, and C.-C. Chiang, “A wireless hierarchical routing protocol with group mobility,” in *Proceedings of the IEEE Wireless Communications and Networking Conference (WCNC)*, vol. 3, 1999, pp. 1538–1542.
- [174] V. Park and M. S. Corson, “Temporally-ordered routing algorithm (TORA) version 1 functional specification,” Internet-Draft, draft-ietf-manet-tora-spec-00. txt, Tech. Rep., 1997.

- [175] M. Käsemann, H. Füßler, H. Hartenstein, and M. Mauve, “A reactive location service for mobile ad hoc networks,” *Technical reports*, vol. 2, 2004.
- [176] J. Li, J. Jannotti, D. S. De Couto, D. R. Karger, and R. Morris, “A scalable location service for geographic ad hoc routing,” in *Proceedings of the 6th annual ACM international conference on Mobile computing and networking*, 2000, pp. 120–130.
- [177] R. Shirani, M. St-Hilaire, T. Kunz, Y. Zhou, J. Li, and L. Lamont, “On the delay of reactive-greedy-reactive routing in unmanned aeronautical ad-hoc networks,” *Procedia Computer Science*, vol. 10, pp. 535–542, 2012.
- [178] E. Sakhaee, A. Jamalipour, and N. Kato, “Aeronautical ad hoc networks,” in *Proceedings of the IEEE Wireless Communications and Networking Conference (WCNC 2006)*, vol. 1, 2006, pp. 246–251.
- [179] E. Sakhaee and A. Jamalipour, “A new stable clustering scheme for pseudo-linear highly mobile ad hoc networks,” in *Proceedings of the IEEE Global Telecommunications Conference (GLOBECOM’07)*, 2007, pp. 1169–1173.
- [180] M. Iordanakis, D. Yannis, K. Karras, G. Bogdos, G. Dilintas, M. Amirfeiz, G. Colangelo, and S. Baiotti, “Ad-hoc routing protocol for aeronautical mobile ad-hoc networks,” in *Proceedings of the Fifth International Symposium on Communication Systems, Networks and Digital Signal Processing (CSNDSP)*. Citeseer, 2006.
- [181] L. Lin, Q. Sun, S. Wang, and F. Yang, “A geographic mobility prediction routing protocol for ad hoc UAV network,” in *Proceedings of the IEEE Globecom Workshops (GC Wkshps)*, 2012, pp. 1597–1602.
- [182] B. Karp and H.-T. Kung, “GPSR: Greedy perimeter stateless routing for wireless networks,” in *Proceedings of the 6th annual ACM international conference on Mobile computing and networking*, 2000, pp. 243–254.
- [183] L. Lin, Q. Sun, J. Li, and F. Yang, “A novel geographic position mobility oriented routing strategy for UAVs,” *Journal of Computational Information Systems*, vol. 8, no. 2, pp. 709–716, 2012.
- [184] T. Camp, J. Boleng, and V. Davies, “A survey of mobility models for ad hoc network research,” *Wireless communications and mobile computing*, vol. 2, no. 5, pp. 483–502, 2002.
- [185] D. Medina, F. Hoffmann, F. Rossetto, and C. Rokitansky, “A crosslayer geographic routing algorithm for the airborne internet,” in *Proceedings of the IEEE International Conference on Communications (ICC)*, 2010, pp. 1–6.
- [186] D. Medina, F. Hoffmann, F. Rossetto, and C. Rokitansky, “Routing in the airborne internet,” in *Proceedings of the IEEE Integrated Communications Navigation and Surveillance Conference (ICNS)*, 2010.

- [187] D. Medina, F. Hoffmann, F. Rossetto, and C. Rokitansky, “North atlantic in-flight internet connectivity via airborne mesh networking,” in *Proceedings of the IEEE Vehicular Technology Conference (VTC Fall)*, 2011, pp. 1–5.
- [188] D. Medina, F. Hoffmann, F. Rossetto, and C. Rokitansky, “A geographic routing strategy for north atlantic in-flight internet access via airborne mesh networking,” *IEEE/ACM Transactions on Networking (TON)*, vol. 20, no. 4, pp. 1231–1244, 2012.
- [189] E. Kuiper and S. Nadjm-Tehrani, “Geographical routing with location service in intermittently connected MANETs,” *IEEE Transactions on Vehicular Technology*, vol. 60, no. 2, pp. 592–604, 2011.
- [190] A. Jabbar and J. P. Sterbenz, “AeroRP: A geolocation assisted aeronautical routing protocol for highly dynamic telemetry environments,” in *Proceedings of the International Telemetering Conference, Las Vegas, NV*, 2009.
- [191] K. Peters, A. Jabbar, E. K. Etinkaya, and J. P. Sterbenz, “A geographical routing protocol for highly-dynamic aeronautical networks,” in *Proceedings of the IEEE Wireless Communications and Networking Conference (WCNC)*, 2011, pp. 492–497.
- [192] S. Hyeon, K.-I. Kim, and S. Yang, “A new geographic routing protocol for aircraft ad hoc networks,” in *Proceedings of the 29th IEEE Digital Avionics Systems Conference (DASC)*, 2010, pp. 2.E.2–1–2.E.2–8.
- [193] M. Le, J.-S. Park, and M. Gerla, “UAV assisted disruption tolerant routing,” in *Proceedings of the IEEE Conference on Military Communications (MILCOM)*, 2006, pp. 1–5.
- [194] O. S. Oubbati, N. Lagraa, A. Lakas, and M. B. Yagoubi, “IRTIV: Intelligent routing protocol using real time traffic information in urban vehicular environment,” in *Proceedings of the 6th International Conference on New Technologies, Mobility and Security (NTMS)*, 2014, pp. 1–4.
- [195] P. Shilin, R. Kirichek, A. Paramonov, and A. Koucheryavy, “Connectivity of vanet segments using uavs,” in *Proceedings of the 16th International Conference and 9th Conference on Internet of Things, Smart Spaces, and Next Generation Networks and Systems: (NEW2AN 2016), (ruSMART 2016)*, 2016, pp. 492–500.
- [196] J. Härri, F. Filali, C. Bonnet, and M. Fiore, “Vanetmobisim: generating realistic mobility patterns for vanets,” in *Proceedings of the 3rd international workshop on Vehicular ad hoc networks*. ACM, 2006, pp. 96–97.
- [197] S. M. Mousavi, H. R. Rabiee, M. Moshref, and A. Dabirmoghaddam, “Mobisim: A framework for simulation of mobility models in mobile ad-hoc networks,” in *Proceedings of the Third IEEE International Conference on Wireless and Mobile*

Computing, Networking and Communications (WiMOB 2007), pages=82–82, year=2007, organization=IEEE.

- [198] L. Gupta, R. Jain, and G. Vaszkun, “Survey of important issues in UAV communication networks,” *IEEE Communications Surveys & Tutorials*, vol. 18, no. 2, pp. 1123–1152, 2016.
- [199] Y. Zhou, N. Cheng, N. Lu, and X. S. Shen, “Multi-UAV-aided networks: Aerial-ground cooperative vehicular networking architecture,” *IEEE Vehicular Technology Magazine*, vol. 10, no. 4, pp. 36–44, 2015.
- [200] W. Fisher, “Development of dsrc/wave standards,” *Annapolis: IEEE*, 2007.
- [201] C. V. S. C. Consortium *et al.*, “Vehicle safety communications project: Task 3 final report: identify intelligent vehicle safety applications enabled by dsrc,” *National Highway Traffic Safety Administration, US Department of Transportation, Washington DC*, 2005.
- [202] C. Sommer, D. Eckhoff, R. German, and F. Dressler, “A computationally inexpensive empirical model of ieee 802.11 p radio shadowing in urban environments,” in *Proceedings of the Eighth IEEE International Conference on Wireless On-Demand Network Systems and Services (WONS)*, 2011, pp. 84–90.
- [203] K. Fall and K. Varadhan, “The network simulator (ns-2),” *URL: <http://www.isi.edu/nsnam/ns>*, 2007.
- [204] K. Dalamagkidis, “Classification of UAVs,” in *Handbook of Unmanned Aerial Vehicles*. Springer, 2015, pp. 83–91.
- [205] J. J. Ramos, S. M. Maeta, L. G. Mirisola, S. S. Bueno, M. Bergerman, B. G. Faria, G. E. Pinto, and A. H. Bruciapaglia, “Internet-based solutions in the development and operation of an unmanned robotic airship,” *Proceedings of the IEEE*, vol. 91, no. 3, pp. 463–474, 2003.
- [206] W. Su, S.-J. Lee, and M. Gerla, “Mobility prediction and routing in ad hoc wireless networks,” *International Journal of Network Management*, vol. 11, no. 1, pp. 3–30, 2001.
- [207] K. Donald *et al.*, “The art of computer programming, volume 2: Semi numerical algorithms,” 1998.
- [208] M. Behrisch, L. Bieker, J. Erdmann, and D. Krajzewicz, “SUMO—simulation of urban mobility: an overview,” in *Proceedings of the Third International Conference on Advances in System Simulation (SIMUL 2011)*, 2011.
- [209] M. Haklay and P. Weber, “Openstreetmap: User-generated street maps,” *IEEE Pervasive Computing*, vol. 7, no. 4, pp. 12–18, 2008.
- [210] O. S. Oubbati, A. Lakas, F. Zhou, M. Güneş, and M. B. Yagoubi, “A Survey on Position-based Routing Protocols for Flying Ad hoc Networks (FANETs),” *Vehicular communications*, 2017.