



HAL
open science

Models and algorithms for two-echelon capacitated facility location problem with facility size selection

Tingying Wu

► **To cite this version:**

Tingying Wu. Models and algorithms for two-echelon capacitated facility location problem with facility size selection. Operations Research [math.OC]. Université Paris-Saclay; Université d'Evry-Val-d'Essonne; Xi'an Jiaotong University, 2015. English. NNT : 2015SACLE029 . tel-01758586

HAL Id: tel-01758586

<https://hal.science/tel-01758586>

Submitted on 10 Apr 2018

HAL is a multi-disciplinary open access archive for the deposit and dissemination of scientific research documents, whether they are published or not. The documents may come from teaching and research institutions in France or abroad, or from public or private research centers.

L'archive ouverte pluridisciplinaire **HAL**, est destinée au dépôt et à la diffusion de documents scientifiques de niveau recherche, publiés ou non, émanant des établissements d'enseignement et de recherche français ou étrangers, des laboratoires publics ou privés.

THESE DE DOCTORAT
DE
XI'AN JIAOTONG UNIVERSITY
ET DE
L'UNIVERSITE PARIS-SACLAY
PREPAREE A L'UNIVERSITE D'EVRY VAL-D'ESSONNE

ÉCOLE DOCTORALE N°580
STIC: Sciences et technologies de l'information et de la communication

Spécialité de doctorat: Mathématiques et Informatique

Par

Mr Tingying WU

Modèles et algorithmes pour les problèmes de localisation de sites
à deux échelons avec la sélection de taille

Thèse présentée et soutenue à Xi'an (Chine), le 16 décembre 2015:

Composition du Jury :

M. Franck DELAPLACE, Professeur, Université d'Evry Val-d'Essonne, Examineur et Présidente du Jury
M. Ada CHE, Professeur, Northwestern Polytechnical University, Rapporteur
M. Roberto WOLFLER CALVO, Professeur, Université de Paris 13, Rapporteur
Mme Feng CHU, Professeure, Université d'Evry Val-d'Essonne, Directeur de thèse
M. Zhili ZHOU, Professeur, Xi'an Jiaotong University, Co-Directeur de thèse
M. Zhen YANG, professeur adjoint, Xi'an Jiaotong University, Co-encadrant de thèse

Models and algorithms for two-echelon capacitated facility location problem with facility size selection

by

Tingying WU

Laboratoire d'informatique, biologie intégrative et systèmes
complexes (IBISC)

Université d'Evry Val d'Essonne, France

And

School of Management

Xi'an Jiaotong University, China

Supervisors: Prof. Feng CHU and Prof. Zhili ZHOU

Vice-supervisor : Zhen YANG

December 16, 2015

Acknowledgements

Firstly, I would like to thank my supervisors, Prof. Feng CHU and Prof. Zhili ZHOU, for their support and guidance throughout my PhD. Their invaluable advices were instrumental not only for my success during my studies, but also to steer me in the right direction and help me grow to be a more mature researcher. In particular, I would like to thank my vice-supervisor, Prof. YANG, who have helped me in all different aspects of my life.

I would like to thank Prof. DELAPLACE, WOLFLER CALVO and CHE for all their advices and availabilities in helping me with all my problems. I highly appreciate what they have done with my thesis. Their precious suggestions are important for improving my thesis.

I would like to thank all my friends and colleagues at XJTU and UEVE(UPSAY) not only for helpful discussions, insights and advices, but especially for making these last four years a lot of fun.

Finally, I would like to thank all my family, for supporting me in all my decisions and encouraging me to pursue my dreams. In particular, I would like to thank my parents, brothers and sister, for helping me put things into perspective and for giving a sense of purpose to all my endeavors.

R ésum é

La localisation de sites est des d écidions strat égiqes les plus importantes pour les entreprises dans le contexte de la mondialisation d'aujourd'hui. Les travaux existant dans la litt érateure traitant ce type de probl èmes se concentrent principalement sur la d étermination de l'emplacement des sites et des flux de produits provenant les sites localis és aux clients dans le but de minimiser le co ût total de construction, de production et logistiques. Cependant, il est tr ès important de bien choisir simultan ément la capacit é et la localisation des sites parce que la taille des sites a une grande influence sur ces co ûts sur le long terme. La d étermination de la location et de capacit és des sites reste encore un probl ème ouvert.

Dans cette th èse, nous étudions trois nouvelles variantes de probl èmes de localisation de sites à deux échelons avec la s élection de taille (TECFLP). Les deux premi ères parties concentrent sur les TECFLPs avec s élection s éparée de taille d'usines ou de d épôts. La troisi ème partie étudie le TECFLP avec s élection simultanée des tailles d'usines et de d épôts. Pour ces probl èmes, trois mod èles de programmation linéaire mixte sont propos és. Ensuite les approches bas és sur la relaxation lagrangienne selon les caract éristiques de chaque probl ème sont d évelopp és. Pour am éliorer les meilleures solutions propos és par les approches de relaxation lagrangienne, une m éthode de recherche tabou, une m éthode hybride de recherche tabou et à voisinage variable, une m éthode hybride du recuit simul é et de la recherche tabou sont respectivement adapt és pour ces trois probl èmes. Les algorithmes d évelopp és sont test és et évalu és à travers 810 instances g én ées al éatoirement. Les r ésultats num ériques montrent que nos m éthodes sont capables de fournir des solutions de qualit é avec un temps de calcul raisonnable.

Mots-cl és: localisation de sites; choix de taille de sites; relaxation lagrangienne; recherche tabou; m éthode hybride de recherche tabou et à voisinage variable; m éthode hybride du recuit simul é et de la recherche tabou

Abstract

Facility location is one of the most important strategic decisions for firms in globalization. Previous works on facility location in the literature mainly focus on determining the locations of facilities and the flows of products from facilities to customers with the goal of minimizing the sum of facility opening costs, production and logistic costs. However, it's very important to determine at the same time the appropriate sizes for these facilities because they greatly affects these costs on the long term. Determining facility location and size is always an open problem.

In this thesis, we study three new two-echelon capacitated facility location problems (TECFLP) with facility size selection. The two first parts of the wok focus on two-echelon facility location problems with plant and depot size selection, respectively. The third part concentrates on TECFLP considering simultaneously plant and depot size selection. For these problems, three corresponding mixed integer programming models are formulated and then Lagrangean relaxation approaches according to the problems' characteristics are developed. To further improve the best solutions obtained by the Lagrangean Relaxation approaches, a tabu search, a hybrid variable neighborhood tabu search and a hybrid simulated annealing tabu search are adapted for the three problems respectively. The developed algorithms are tested and evaluated through 810 randomly generated instances. Computational results show ours algorithms can provide high quality solutions within a reasonable computation time.

Keywords: Facility location, Facility size, Lagrangean relaxation, Tabu search, Hybrid variable neighborhood tabu search, Hybrid simulated annealing tabu search

Contents

ACKNOWLEDGEMENTS	I
RESUME.....	III
ABSTRACT.....	V
NOTATIONS.....	IX
ABBREVIATIONS.....	XI
LIST OF FIGURES	XIII
LIST OF TABLES.....	XV
CHAPTER 1.....	1
INTRODUCTION	1
1.1 BACKGROUND	3
1.2 CONTRIBUTIONS	5
1.3 ORGANIZATION OF THE THESIS	6
CHAPTER 2.....	9
LITERATURE REVIEW	9
2.1 FACILITY LOCATION PROBLEMS.....	10
2.1.1 Single-stage facility location problems.....	10
2.1.2 Two-stage facility location problem.....	15
2.1.3 Facility location problem with facility size selection or nonlinear variable cost.....	18
2.2 LAGRANGEAN RELAXATION AND SUBGRADIENT OPTIMIZATION.....	18
2.2.1 Lagrangean relaxation.....	19
2.2.2 Subgradient optimization	20
2.3 METAHEURISTICS	21
2.3.1 Tabu search	21
2.3.2 Variable neighborhood search.....	22
2.3.3 Simulated annealing.....	23
CHAPTER 3.....	27
TWO-ECHELON CAPACITATED FACILITY LOCATION PROBLEM WITH PLANT SIZE SELECTION.....	27
3.1 INTRODUCTION	29
3.2 PROBLEM FORMULATION.....	30
3.3 LAGRANGEAN RELAXATION APPROACH FOR THE TECFLP-PSS	33
3.3.1 Lagrangean relaxation model of the TECFLP-PSS	33
3.3.2 Subgradient optimization for the TECFLP-PSS	35
3.3.3 Feasible solution construction.....	36
3.4 TABU SEARCH FOR THE TECFLP-PSS	39
3.4.1 Move and neighborhood definitions	39
3.4.2 Evaluation of moves	39
3.4.3 Search strategy	40
3.5 COMPUTATIONAL RESULTS	41
3.5.1 Test instances	41
3.5.2 Results.....	42
3.6 CONCLUSIONS	49
CHAPTER 4.....	51
TWO-ECHELON CAPACITATED FACILITY LOCATION PROBLEM WITH DEPOT SIZE SELECTION.....	51
4.1 INTRODUCTION	53
4.2 PROBLEM FORMULATION.....	54

4.3 LAGRANGEAN RELAXATION APPROACH FOR THE TECFLP-DSS	57
4.3.1 Lagrangean relaxation model of the TECFLP-DSS.....	57
4.3.2 Subgradient optimization for the TECFLP-DSS.....	59
4.3.3 Feasible solution construction.....	60
4.4 HYBRID VARIABLE NEIGHBORHOOD TABU SEARCH ALGORITHM FOR THE TECFLP-DSS	61
4.4.1 Moves and neighborhoods definitions	62
4.4.2 Tabu list.....	62
4.4.3 The steps of the HVNTS.....	62
4.5 COMPUTATIONAL RESULTS	64
4.5.1 Test instances	64
4.5.2 Results.....	64
4.6 CONCLUSIONS	72
CHAPTER 5	73
TWO-ECHOLON CAPACITATED FACILITY LOCATION PROBLEM WITH PLANT AND DEPOT SIZE SELECTION	73
5.1 INTRODUCTION	75
5.2 PROBLEM FORMULATION	76
5.3 LAGRANGEAN RELAXATION APPROACH FOR THE TECFLP-PDSS	78
5.3.1 Lagrangean relaxation model of the TECFLP-PDSS	79
5.3.2 Subgradient optimization for the TECFLP-PDSS	80
5.3.3 Feasible solution construction.....	81
5.4 HYBRID SIMULATED ANNEALING TABU SEARCH ALGORITHM FOR THE TECFLP-PDSS	84
5.4.1 Move and neighborhood definitions	84
5.4.2 Tabu list.....	84
5.4.3 Annealing strategy	85
5.4.4 The steps of the HSATS	85
5.5. COMPUTATIONAL RESULTS	86
5.5.1 Test instances	86
5.5.2 Results.....	87
5.6 CONCLUSIONS	97
CHAPTER 6	99
CONCLUSIONS AND FUTURE RESEARCHES	99
REFERENCES	105

Notations

I	the set of potential plants;
J	the set of potential depots;
K	the set of customers;
R_i	the set of production sizes of the plant $i \in I$;
S_j	the set of possible sizes of the depot $j \in J$;
cp_i	the capacity of the plant $i \in I$;
cp_{ir}	the capacity of the plant $i \in I$ with the production size $r \in R_i$;
cd_j	the capacity of the depot $j \in J$;
cd_{js}	the capacity of the depot $j \in J$ with the size $s \in S_j$;
d_k	the demand of the customer $k \in K$;
fp_i	the fixed cost of opening the plant $i \in I$;
fp_{ir}	the fixed cost of the plant $i \in I$ with the production size $r \in R_i$;
fd_j	the fixed cost of the depot $j \in J$;
fd_{js}	the fixed cost of opening the depot $j \in J$ with the size $s \in S_j$;
p_{ir}	the unit production cost of the plant $i \in I$ with the size $r \in R_i$;
h_{js}	the unit handling cost at the depot $j \in J$ with the size $s \in S_j$;
t_{ij}	the unit transportation cost from the plant $i \in I$ to the depot $j \in J$;
c_{jk}	the unit assignment cost of the customer $k \in K$ to the depot $j \in J$;

Abbreviations

CFLP:	Capacitated facility location problem;
CFLPSS:	Capacitated facility location problem with single source;
TSCFLP:	Two-stage capacitated facility location problem;
TSCFLPSS:	Two-stage capacitated facility location problem with single source;
TSUFLP:	Two-stage uncapacitated facility location problem;
TECFLP-PSS:	Two-echelon capacitated facility location problem with plant size selection;
TECFLP-DSS:	Two-echelon capacitated facility location problem with depot size selection;
TECFLP-PDSS:	Two-echelon capacitated facility location problem with plant and depot size selection;
UFLP:	Uncapacitated facility location problem;
TS:	Tabu search;
SA:	Simulated annealing;
VNS:	Variable neighborhood search;
HVNTS:	Hybrid variable neighborhood tabu search;
HSATS:	Hybrid simulated annealing tabu search;

List of Figures

2.1 The structure of a single-stage facility location problem.....	10
2.2 The structure of a two-stage facility location problem.....	15
2.3 The principal steps of the TS algorithm	21
2.4 The principal steps of the basic VNS algorithm	23
2.5 The principal steps of the SA algorithm	24
3.1 The structure of the TECFLP-PSS	31
3.2 An example of the cost function of a plant	31
4.1 The structure of the TECFLP-DSS	55
4.2 An example of the cost function of a depot	55
5.1 The structure of the TECFLP-PDSS	77

List of Tables

3.1 Computational results and comparisons of the TS bounds with those of CPLEX	43
3.2 Computational results on the instances with different ratio r_{cpd}	44
3.3 Computational results on the instances with different ratio r_{cdd}	46
3.4 Computational results on the instances with different numbers of plant size	48
4.1 Computational results and comparisons of the HVNTS bounds with those of CPLEX	65
4.2 Computational results on the instances with different plant capacities	67
4.3 Computational results on the instances with different depot capacities	68
4.4 Computational results on the instances with different numbers of depot size	70
5.1 Computational results and comparisons of the HSATS bounds with those of CPLEX	88
5.2 Computational results for the instances with changes of plant capacities	90
5.3 Computational results for the instances with changes of depot capacities	91
5.4 Computational results for the instances with changing numbers of plant size	93
5.5 Computational results for the instances with changing numbers of depot size	95

Chapter 1

Introduction

This thesis investigates models and methods for two-echelon capacitated facility location problems with facility size selection encountered in two-stage supply chain system. It mainly concerns optimizing location and size of facility in two-stage supply chain system. The goal of this research is to develop models and methods for designing two-stage supply chain network system. In this chapter, the background of the thesis is firstly introduced. Then the contributions and organization of this thesis are presented.

1.1 Background

Most private firms and public agencies have faced the problem of locating facilities over spatial dimensions to provide certain service functions to their distributed clients or customers. Industrial firms need to locate a variety of facilities in the supply chain network system including manufacturing and assembly plants, warehouse and retail outlets. Government agencies must determine locations of public service facilities such as schools, hospitals, fire stations, ambulance bases and landfill. In every case, the operational efficiency and system benefit depend on the choices of facility locations. A good location design could maximize the service benefit while saving as much infrastructure investment as possible.

Deciding the best number, locations and sizes of facilities are the key issues in supply chain network design. This decision in literatures is called “facility location problem”. Generally facility location problem involves the determination of the number, locations and sizes of facilities, and the assignment of the customers to the facilities or the transportation from the facilities to the customers.

The strategic decision of locating facilities is one of the most critical issues for firms and has significant impacts on the tactical and operational costs of supply chain network over a long time horizon since the logistics/distribution costs constitute an important part of the total expenditure of a firm. With the rapid growth of telecommunication and transportation technologies, the competition in market is getting more and more fierce. To survive in the war of business, firms have to invest in and focus on their own supply chain in order to improve the customer service level without increasing of costs. To achieve this goal, one important issue for those firms is effective designing their supply chain networks. Appropriately facility location can potentially increase the global profit and competitiveness of firms. Hence, optimizing the supply chain network is of fundamental importance for the firms aiming to reduce their logistics costs and maintain their competitive advantages.

The current facility location problems in the literature mainly involves determining the best locations for facilities. Given a set of potential locations for facilities and a set of customers, the facility location problem is to locate facilities in such a way that the total cost for assigning customers to facilities and satisfying the service (or demand) required by customers is minimized. The cost considered is the sum of the fixed costs of opening facilities and the costs for assigning customers to specific facilities which depend on, for example, the distance between them. The facility location problem can be classified into different categories depending on the properties assumed: 1) single or multistage, 2) uncapacitated or capacitated

facility, or 3) single or multiple sourcing in terms of customer-depot assignment. For more details, we refer readers to the surveys of Klose and Drexl (2005), ReVelle et al. (2008) and Melo et al. (2009).

In the classical facility location problems, the size of a facility is assumed to be fixed, i.e., either capacitated or uncapacitated. The facility opening cost is assumed to be a constant and the unit production or handling cost is assumed to be the same, thus it can be merged with other linear connection cost. The decision of the size of facility is not included in these facility location problems. However, in some practical situations it is often necessary to consider several possible sizes for each potential facility location. Firms need also to determine the sizes of facilities. The size of a facility can significantly affect the fixed opening cost of the facility. As production or handling volume increases, the fixed investment for constructing the facility increases. In addition, as production or handling volume increases, cost savings are achieved through economies of scale. The unit production or handling cost under larger size of a facility is lower than that under smaller sizes of the same facility. How to make a decision to optimize facility location and select facility size simultaneously is a significant problem in supply chain network design.

Unfortunately, only limited research has been conducted on single-stage facility location problem which considers simultaneously the location and size of facility or nonlinear variable cost. As far as we know there is no he literatures on two-stage facility location problem which consider simultaneously the location and size of facility or nonlinear variable cost are not found. Lee (1993) investigated a multi-products capacitated facility location problem with facility type choice. Mazzola and Neebe (1999) dealt with the same problem and developed a Lagrangean based heuristic. Holmberg and Ling (1997) studied a facility location problem with facility size choice and staircase production cost. Taniguchi et al. (1999) optimized the size and location of public logistics terminals. Wu et al. (2006) considered a capacitated facility location problem with general non-linear setup cost. Dupont (2008) investigated a facility location problem in which the total cost for each opened facility is a concave function of the quantity delivered by this facility. Carrizosa et al. (2012) studied a nonlinear minsum facility location problem.

The two-stage facility location problem is one of the most commonly encountered problem in the two-stage supply chain system design. Similar as locating facilities in the context of single-stage supply chain network system, it is significant to select facility size when locating facilities in the context of two-stage supply chain system since the facility size can affects the fixed facility opening cost and the unit producing or handling cost is different under different sizes of facilities because of economies of scale. To the best of our knowledge, although the optimizing of facility location and size have been considered simultaneously for the single-stage supply chain network system in the literature, the facility location and size have not been investigated simultaneously in the two-stage supply chain network system. To fill this gap, we concentrate on the optimizing of the location and size of facilities in the context of two-stage supply chain network system in this thesis. The aims of the thesis is optimize the location and size of plants and/or depots, determine the product flows from the plants to the depots and the assignments of the customers to the depots to satisfy the customers' demands at a minimum sum of cost. This cost consists of the fixed plant and depot opening costs, the producing costs at plants and/or handling costs at the depots, the transportation costs from

the plants to the depots and the customer-depot assignment costs.

1.2 Contributions

In this thesis, we study three new two-echelon capacitated facility location problems (TECFLP) with facility size selection. The first and second parts of our work focus on two-echelon capacitated facility location problems with plant size selection and depot size selection, respectively. The third part concentrates on the TECFLP with plant and depot size selections simultaneously. For these problems, three corresponding mixed integer programming models (MIP) are formulated and then Lagrangean relaxation based approaches according to the problems' characteristics have been developed. To further improve the best upper bounds found in the Lagrangean relaxation approaches, a tabu search (TS), a hybrid variable neighborhood tabu search (HVNTS) and a hybrid simulated annealing tabu search (HSATS) are designed for these three problems respectively. All algorithms are evaluated by numerous randomly generated instances. Computational results show our methods can provide high quality solutions with reasonable computational time.

More specifically, the main contributions of this thesis is as follows:

A two-echelon capacitated facility location problems with plant size selection (TECFLP-PSS) encountered in two-stage supply chain system but not been investigated in the literature is studied. For this problem, a mixed integer linear programming model for the problem is formulated. Since the problem is NP-hard, we focus on find near optimal solutions for it. Thus a Lagrangean relaxation approach is proposed to achieve a lower bound and upper bound of the problem. The upper bound is later further improved by a tabu search (TS). A total of 245 instances with different sizes and parameters are randomly generated and tested to evaluate the performance of the proposed algorithms. The computational results demonstrate that all of the instances can be solved in a reasonable time with the average gaps below 1.66%, even for instances that have up to 50 potential plants with 6 possible sizes each, 200 potential depots and 400 customers.

A two-echelon capacitated facility location problems with depot size selection (TECFLP-DSS) encountered in two-stage supply chain system is studied. For this problem, a mixed integer linear programming model for the problem is formulated and a Lagrangean relaxation approach is proposed to achieve a lower bound and an upper bound of the problem. A hybrid variable neighborhood tabu search (HVNTS) is proposed to further improve the best upper bound found in the Lagrangean relaxation approach. A total of 245 instances with different sizes and parameters are randomly generated and tested to evaluate the performance of proposed algorithms. The computational results show that the proposed algorithms can solve all of the instances with average gaps below 1.16% in an acceptable time, even for the instances that have up to 50 potential plants, 100 potential depots with 6 depot sizes each and 400 customers.

A two-echelon capacitated facility location problems with plant and depot size selection (TECFLP-PDSS) encountered in two-stage supply chain system is studied. For this problem, a mixed integer linear programming model for the problem is formulated and a Lagrangean relaxation approach is proposed to

achieve a lower bound and an upper bound of the problem. A hybrid simulated annealing tabu search (HSATS) is proposed to further improve the best upper bound found in the Lagrangean relaxation approach. A total of 320 instances with different sizes and parameters are randomly generated and tested to evaluate the performance of proposed algorithms. The computational results show that the proposed approach can solve all of the instances in a reasonable time with the average gaps below 1.75%, even for instances that have up to 50 potential plants with 6 possible sizes each, 100 potential depots with 6 possible sizes each, and 400 customers.

1.3 Organization of the thesis

The rest of this thesis is organized as follows:

In Chapter 2, a detailed literature review of single-stage facility location problem, the two-stage facility location problem, the Lagrangean relaxation method and the basic ideas of the metaheuristic technologies used in this thesis are given.

In Chapter 3, we focus our attention on a two-echelon capacitated facility location problem with plant size selection (TECFLP-PSS). This problem allow us to deal with both different sizes for plants and different production costs at different levels of production at a plant. A mixed integer linear programming model for the problem is formulated for the TECFLP-PSS and a Lagrangean relaxation approach is proposed to find a tight lower bound and a high quality near-optimal solution for the TECFLP-PSS. At each Lagrangian iteration, a heuristic is developed to construct a feasible solution of the TECFLP-PSS. This heuristic includes three stages, opening plant and selecting plant size, opening depots and determining the assignments of the customers to the opened depots, and solving a transportation problem to determining the product flows from the plants to the depots. After the Lagrangian relaxation approach, the best feasible solution is improved by a tabu search algorithm. Instances are randomly generated and tested to evaluate the performance of proposed algorithms.

In Chapter 4, we investigate a two-echelon capacitated facility location problem with depot size selection (TECFLP-DSS). This problem allow us to deal with both different sizes for depots and different handling costs at different levels of handling at a depot. For the TECFLP-DSS, a mixed integer linear programming model for the problem is formulated and a Lagrangian relaxation approach based on the problem properties is developed to find a tight lower bound and a high quality near-optimal solution for the TECFLP-DSS. At each Lagrangean relaxation iteration, a heuristic is developed to construct a feasible solution of the TECFLP-PSS. After the Lagrangian relaxation approach, a hybrid variable neighborhood tabu search algorithm is designed to further improve the best feasible solution found in the Lagrangean relaxation approach. Instances are randomly generated and tested to evaluate the performance of proposed algorithms.

In Chapter 5, we concentrate a two-echelon capacitated facility location problem with plant and depot size selection (TECFLP-PDSS). This problem allow us to deal with both different sizes for plants and depots, and different production costs at different levels of production at a plant and different handling costs

at different levels of handling at a depot. A mixed integer linear programming model for the problem is formulated and a Lagrangean relaxation approach is proposed to find a tight lower bound and a high quality near-optimal solution for the TECFLP-PDSS. At each Lagrangian iteration, a heuristic is developed to construct a feasible solution of the TECFLP-PDSS. This heuristic includes, opening plant and selecting plant size, opening depots and selecting depots size, determining the assignments of the customers to the opened depots, and solving a transportation problem to determining the product flows from the plants to the depots. After the Lagrangian relaxation approach, the best feasible solution is improved by a tabu search algorithm. Instances are randomly generated and tested to evaluate the performance of proposed algorithms.

Finally, in Chapter 6, we conclude the thesis and give some perspectives for the future research.

Chapter 2

Literature review

This chapter provides literature reviews on facility location problems and some technologies in detail, which will be used for solution algorithms in this thesis. Firstly, several related facility location problems, their models and the works which have contributed to the resolution of these models are presented. Then the principles of some technologies are introduced in detail, which will be used for solution algorithms for our problems.

2.1 Facility location problems

As stated, the facility location problem can be classified into different categories depending on the properties assumed, such as single or multistage, uncapacitated or capacitated facility and single or multiple sourcing in terms of customer-depot assignment. For more details, we refer readers to the surveys of Klose and Drexl (2005), ReVelle et al. (2008) and Melo et al. (2009). We first review the models and solution techniques for the single-stage facility location problems and the two-stage facility location problems and then review facility location problem with facility size selection or nonlinear variable cost.

2.1.1 Single-stage facility location problems

In the single-stage facility location problem where there are in fact two stages and two decision levels. The first stages is the facilities or plants, where the decision to be made is the choice of which plants to open, the second stage is the customers where the decision is which customers are assigned to the chosen subset of plants. The overall solution to the single-stage facility location problem defines which plants are open and the flow of demand from plants to customers. The structure of a single-stage facility location problem is presented in Fig. 2.1, where the first stage is the plants, the second is the customers.

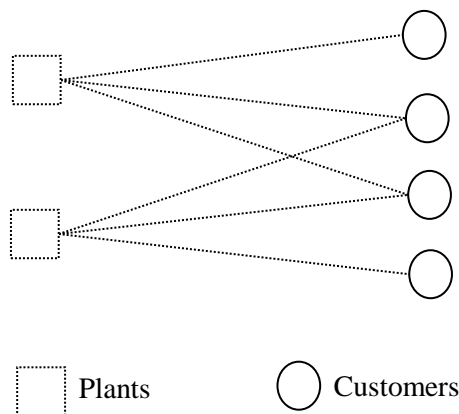

Fig. 2.1 The structure of a single-stage facility location problem

The single-stage facility location problems consider opening a set of facilities from a set of potential sites and letting those open facilities satisfy the demand of customers in a single-stage supply chain network system. The objective of the problem is to minimize the sum of the fixed cost of opening facilities and the

shipping cost from the facilities to the customers. Many kinds of the single-stage facility location problems have been intensively studied in the literature, such as the uncapacitated facility location problem (UFLP), the capacitated facility location problem (CFLP) and the capacitated facility location problem with single source constraints (CFLPSS), etc. The models and solution methods of these models are briefly reviewed in the following.

2.1.1.1 Simple or uncapacitated facility location problem

Let I be a set of potential sites of facilities, K denotes a set of customers, $fp_i, \forall i \in I$ be the fixed opening cost of facility i and $c_{ik}, \forall i \in I, \forall k \in K$ is the transportation cost between facility i and customer k . Each customer is associated with a demand $d_k, \forall k \in K$. The uncapacitated facility location problem (UFLP) is to locate facilities among a set of potential sites to serve the customers such that the total cost of the fixed cost of locating the facilities and the transportation cost from the facilities to the customers is minimized. In the UFLP, each facility is assumed to have no limits on its capacity.

Let us define,

u_i 1, if a facility $i \in I$ is opened; otherwise 0;

z_{ik} the fraction of the demand d_k transported from facility i to customer k .

The UFLP can be formulated as the following mixed integer programming,

$$\min \sum_{i \in I} fp_i \cdot u_i + \sum_{i \in I} \sum_{k \in K} c_{ik} \cdot z_{ik} \quad (2-1)$$

$$s.t. \quad \sum_{i \in I} z_{ik} = 1 \quad \forall k \in K \quad (2-2)$$

$$z_{ik} \leq u_i \quad \forall i \in I, k \in K \quad (2-3)$$

$$u_i \in \{0, 1\} \quad \forall i \in I \quad (2-4)$$

$$0 \leq z_{ik} \leq 1 \quad \forall i \in I, k \in K \quad (2-5)$$

The objective (2-1) minimizes the total costs of opening the facilities and shipping the products. The constraints (2-2) guarantee that each customer's demand are satisfied. The constraints (2-3) make sure that no demand is supplied by each closed facility. The constraints (2-4) and (2-5) are standard nonnegativity and integrality constraints for decision variables.

The UFLP has been intensively studied and many solution methods have been proposed in the literature. Kuehn and Hamburger (1963) developed the first heuristic that has two phases. The first phase is a greedy approach, called the ADD method, that starts with all facilities closed, keeps adding (opening) the facility resulting in the maximum decrease in the total cost, and stops if adding any more facility will no longer reduce the total cost. The second phase is a local search method in which an open facility and a closed facility are interchanged as long as such an interchange reduces the total cost. Another greedy heuristic is the DROP method that starts with all facilities open, keeps dropping (closing) the facility that gives the maximum decrease in the total cost, and stops if dropping any more facility will no longer reduce the total cost (Cornuejols et al. 1977, Nemhauser et al. 1978). These early heuristics provided the basis for many

sophisticated heuristics and provided an initial incumbent for many exact solution algorithms (Cornuejols et al. 1977, Nemhauser et al. 1978). Erlenkotter (1978) developed a dual approach for the UFLP. Although this dual approach is an exact algorithm, it can also be used as a heuristic to find good solutions. One effective and widely used heuristic is the Lagrangian method (Beasley, 1993a) that is based on Lagrangian relaxation and subgradient optimization. More recently, Gen et al. (1996) and Vaithyanathan et al. (1996) used artificial neural network approaches to solve UFLP.

In addition to heuristics, there are a variety of exact algorithms for the UFLP, such as the dual approach of Erlenkotter (1978) and the primal-dual approaches of Körkel (1989). Because the UFLP is NP-hard, exact algorithms may not be able to solve large practical problems. The UFLP has been studied extensively and many researchers have made great contributions in developing exact and heuristic solution methods. Krarup and Pruzan (1983) gave excellent surveys and reviews of applications and solution methods.

2.1.1.2 Capacitated facility location problem

When each facility has a limited capacity, the UFLP becomes the capacitated facility location problem (CFLP). In the CFLP, the volume supplied from each facility cannot exceed its capacity and the customers can receive their demand from two or more open plants.

Using the same definition for the decision variables of the UFLP and denoting the capacity of facility i by cp_i , $\forall i \in I$, the CFLP can be formulated as:

$$\min \sum_{i \in I} fp_i \cdot u_i + \sum_{i \in I} \sum_{k \in K} c_{ik} \cdot z_{ik} \quad (2-6)$$

$$s.t. \quad \sum_{i \in I} z_{ik} \cdot d_k \leq cp_i \cdot u_i \quad \forall i \in I \quad (2-7)$$

$$\sum_{i \in I} z_{ik} = 1 \quad \forall k \in K \quad (2-8)$$

$$u_i \in \{0, 1\} \quad \forall i \in I \quad (2-9)$$

$$0 \leq z_{ik} \leq 1 \quad \forall i \in I, k \in K \quad (2-10)$$

The objective (2-6) minimizes the total costs of opening the facilities and shipping the products. The constraints (2-7) make sure that the capacities supplied by each facility is no greater than its capacity. The constraints (2-8) guarantee that each customer's demand are satisfied. The constraints (2-3) and (2-4) are standard nonnegativity and integrality constraints for decision variables.

Many heuristic methods and exact algorithms have been developed to solve it in the last 50 years. Because UFLP and CFLP are closely related, many heuristic methods developed for the UFLP are also extended to the CFLP. As stated, Kuehn and Hamburger (1963) developed the first heuristic method for the UFLP. This heuristic method consists of two phases. The first phase, called ADD, starts with all facilities closed and then the facility that causes the maximum total cost reduction is opened. This phase ends when no more facilities can be opened to reduce the total cost further. The second phase is a local search procedure in which an open facility and a closed facility exchange their status if this exchange reduces the total cost. This heuristic was later extended to the CFLP by Jacobsen (1983). Domschke and Drexl (1985) proposed priority

rules for the ADD procedure to improve its performance in cases where the facilities have distinct capacities and/or distinct fixed operating costs. Feldman et al. (1966) proposed a different strategy for the first phase, named DROP, that was also extended to the CFLP by Jacobsen (1983). In DROP, all facilities are initially open and a facility is closed if closing it results in the maximum reduction in the total cost. This phase ends when closing a facility does not result in any further reduction in the total cost.

Lagrangean relaxation has been applied to several facility location problems. Cornuejols et al. (1991) presented an excellent theoretical analysis of all possible Lagrangean relaxations and the linear programming relaxation for the CFLP, and showed that only relaxations yield distinct bounds. Dominance relations among the relaxations were also discussed. Beasley (1993b) presented a unified framework of using the Lagrangean relaxation to solve different facility location problems. In the proposed framework for the CFLP, constraints (2-7) and (2-8) are relaxed and the solution of the relaxed problem is trivial. Barahona and Chudak (2005) also proposed a Lagrangean relaxation method for the UFLP and the CFLP. Initially they considered the linear programming relaxation of the CFLP and then suggested the Lagrangean relaxation relative to constraints for solving the linear programming problem. They used the volume algorithm (Barahona and Anbil, 2000) in order to maximize the dual objective function. The volume algorithm is an extension of the subgradient method and aims at generating good primal solutions. The name of the method comes from a theorem stating that a primal solution can be obtained from the volume under the faces of the piecewise linear and concave dual objective function.

Several exact algorithms based on branch-and-bound have been proposed. The major differences among these algorithms are in the types of relaxations, the methods of solving the relaxed problem and the strategies to improve the lower bound. Van Roy (1986) implemented the cross decomposition method that combines Benders decomposition and Lagrangean relaxation in order to exploit the primal and dual structures of the CFLP. Leung and Magnanti (1989) introduced a family of facets and valid inequalities for solving the CFLP with equal capacities. Aardal (1998a) proposed new valid inequalities and implemented two branch-and cut algorithms that are tested on small and medium test problems from the literature.

The TS metaheuristic has been successfully applied to a variety of combinatorial optimization problems, but not much research has been reported in using it for the CFLP. The TS heuristic procedure proposed by Grolimund and Ganascia (1997) was applied to the CFLP and limited computational results were reported. However, TS procedures have been developed for more complicated facility location problems, such as those by Delmaire et al. (1999), Filho and Galvão (1998), França et al. (1999), and Tuzun and Burke (1999).

2.1.1.3 Capacitated facility location problem with single source

In the CFLP, if each customer is assumed to be supplied from exactly one facility, it becomes the capacitated facility location problem with single source (CFLPSS). In the CFLPSS, each customer must receive their demand from one open facility, as opposed to receiving their total demand from two or more open facilities.

Let us define

z_{ik} 1, if a customer $k \in K$ is assigned to a facility $i \in I$; otherwise 0.

Using the same definition for the notations of the CFLP and the CFLPSS can be formulated as:

$$\min \sum_{i \in I} fp_i \cdot u_i + \sum_{i \in I} \sum_{k \in K} c_{ik} \cdot z_{ik} \quad (2-11)$$

$$s.t. \quad \sum_{i \in I} z_{ik} \cdot d_k \leq cp_i \cdot u_i \quad \forall i \in I \quad (2-12)$$

$$\sum_{i \in I} z_{ik} = 1 \quad \forall k \in K \quad (2-13)$$

$$u_i \in \{0,1\} \quad \forall i \in I \quad (2-14)$$

$$z_{ik} \in \{0,1\} \quad \forall i \in I, k \in K \quad (2-15)$$

The objective (2-11) minimizes the total costs of opening the facilities and assigning costs. The constraints (2-12) make sure that the capacities supplied by each facility is no greater than its capacity. The constraints (2-13) guarantee that each customer is assigned exactly to one facility. The constraints (2-14) and (2-15) are standard nonnegativity and integrality constraints for decision variables.

The CFLPSS is known to be an NP-hard optimization problem. Different approaches to obtain upper and lower bounds for the CFLPSS are proposed in the literature. One of the most successful approaches for solving the CFLPSS is the so-called Lagrangian heuristics. These heuristics are based on Lagrangian relaxation which decomposes the original problem into a set of smaller and simpler subproblems by introducing Lagrange multipliers and by optimally solving the related Lagrangian dual problem. A feasible solution of the original problem is constructed by some heuristic procedure based on the solution of the Lagrangian relaxation problem. The difference between these heuristics lies in which constraints are relaxed. Klincewicz and Luss (1986) presented an algorithm based on relaxing the facility capacity constraints (2-12). The corresponding Lagrangian subproblems then become uncapacitated facility location problems. Pirkul (1987), Barcelo and Casanovas (1984) and Sridharan (1993) developed algorithms based on relaxing the customer assignment constraints (2-13). The SSCFLP is decomposed into a series of knapsack problems. Beasley (1993) proposed a relaxation on both capacity constraints and assignment constraints and compare the performances of various Lagrangian heuristics. He concluded that Pirkul (1987) provided the best feasible solutions, followed by Beasley (1993), and then Klincewicz and Luss (1986). In addition, other heuristic methods are also proposed for the CFLPSS, such as Delmaire et al. (1999)'s reactive grasp and tabu search based heuristics, Ahuja et al. (2004)'s very large scale neighborhood search algorithm and Díaz (2008)'s scatter search method.

For exact algorithms, Holmberg et al. (1999) developed a Lagrangian based branch-and-bound scheme to find an optimal solution for the CFLPSS. At each branching node, a lower bound is generated by solving the Lagrangian dual problem while a feasible solution is constructed based on the solution of the Lagrangian dual by using a repeated matching heuristic. Díaz and Fernandez (2002) proposed another exact algorithm, a branch-and-price algorithm for the CFLPSS. A column generation procedure for finding upper and lower

bounds is incorporated within a Branch-and-Price framework. The bounding procedure exploits the structure of the problem by using an iterative approach. At each iteration, a two-level optimization problem is considered. The two levels correspond to the two decisions to be taken: first, the selection of a subset of plants to be opened, and then the allocation of clients within the subset of open plants. The second level subproblem is solved using column generation. The algorithm was tested with different sets of instances and the obtained results are satisfactory. Yang et al. (2012) designed a cut-and-solve (CS) based algorithm for the CFLPSS. The CS was proposed by Climer and Zhang (2006) for the traveling salesman problem and can be viewed as a special case of local branching tree.

2.1.2 Two-stage facility location problem

The two-stage facility location problems are natural extensions of the single-stage facility location problems. In the two-stage facility location problems there are in fact three stages, but potentially more than three decision levels. The first or upper-most stage is the plants, where the decision to be made is the choice of which subset of plants to open, the second or central stage is the distribution depots and the decision here is which subset of depot to open. The third stage is the customers and the decision to be made here are to assign customers to open depots to satisfy their service or demand requirements. The decision of the flow of product from the plants to the depots is also made in the two-stage facility location problem. The overall solution to the two-stage facility location problem defines which plants and depots are open and the flow of demand through the system from plants to customers via depots. The structure of a two-stage facility location problem is presented in Fig. 2.2, where the first or upper-most stage is the plants, the second or central stage is the depots and the third stage is the customers.

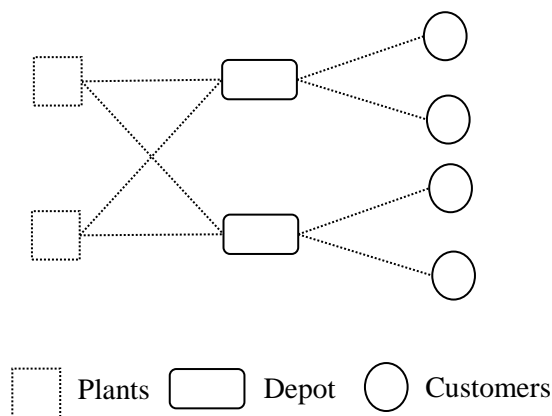

Fig. 2.2 The structure of a two-stage facility location problem

The two-stage facility location problem is a natural extension of the single-stage facility location problem, which considers to locate facilities (depots and/or plants) in a two-stage supply chain network. The two-stage facility location problem involves locating a set of depots or both a set of plants and a set of depots, determining the product flows from the plants to the depots and the assignments of the customers to the depots to satisfy the customers' demands under single or multiple sourcing constraints. The objective the

two-stage facility location problem is to minimize the sum of the opening costs of the facilities, the transportation costs from the plants to the depots and the assignment costs of the customers to the depots. One of the most studied two-stage facility location problem is the two-stage capacitated facility location problem (TSCFLP). Other versions of the two-stage facility location problem have been studied in the literature, such as the two-stage uncapacitated facility location problem (TSUFLP) and the two-stage capacitated facility location problem with single source (TSCFLPSS).

To formulate the TSCFLP, the notations and decision variables used are as follows:

Notations:

- I the set of plants;
- J the set of potential depots;
- K the set of customers;
- cp_i the capacity of the plant $i \in I$;
- cd_j the capacity of the depot $j \in J$;
- d_k the demand of customer $k \in K$;
- fd_j the fixed cost of the depot $j \in J$;
- t_{ij} the unit transportation cost from the plant $i \in I$ to the depot $j \in J$;
- c_{jk} the cost of assigning customer $k \in K$ to the depot $j \in J$;

Decision variables:

- u_i 1, if the plant $i \in I$ is opened; *otherwise* 0.
- v_j 1, if the depot $j \in J$ is opened; *otherwise* 0;
- x_{ij} the quantity of product flow from the plant $i \in I$ to the depot $j \in J$;
- z_{jk} the fraction of the demand d_k of a customer $k \in K$ supplied from the depot $j \in J$;

The TSCFLP can be formulated as:

$$\min \sum_{i \in I} fp_i \cdot u_i + \sum_{i \in I} \sum_{j \in J} t_{ij} \cdot x_{ij} + \sum_{j \in J} fd_j \cdot v_j + \sum_{j \in J} \sum_{k \in K} c_{jk} \cdot z_{jk} \quad (2-16)$$

$$\text{s.t.} \quad \sum_{j \in J} x_{ij} \leq cp_i \cdot u_i \quad \forall i \in I \quad (2-17)$$

$$\sum_{i \in I} x_{ij} - \sum_{k \in K} d_k \cdot z_{jk} = 0 \quad \forall j \in J \quad (2-18)$$

$$\sum_{k \in K} d_k \cdot z_{jk} \leq cd_j \cdot v_j \quad \forall j \in J \quad (2-19)$$

$$\sum_{j \in J} z_{jk} = 1 \quad \forall k \in K \quad (2-20)$$

$$\sum_{i \in I} cp_i \cdot u_i \geq D(K) \quad (2-21)$$

$$\sum_{j \in J} cd_j \cdot v_j \geq D(K) \quad (2-22)$$

$$u_i \in \{0,1\} \forall i \in I \quad (2-23)$$

$$v_j \in \{0,1\} \forall j \in J \quad (2-24)$$

$$x_{ij} \geq 0 \forall i \in I, \forall j \in J \quad (2-25)$$

$$0 \leq z_{jk} \leq 1 \forall j \in J, \forall k \in K \quad (2-26)$$

The objective (2-16) minimizes the total costs of opening the plants and depots, and assigning the customers to the depots. The constraints (2-17) ensure that the total product flows moving out from a plant cannot exceed the capacity. The constraints (2-18) are the flow equilibrium constraints at the depots. The constraints (2-19) address that the demands assigned to an opened depot cannot exceed its capacity. The constraints (2-20) guarantee that each customer is assigned to exactly one depot. The constraints (2-21) and (2-22) are redundant, but they are very useful in tightening the linear relaxation of TSCFLP. The constraints (2-23), (2-24), (2-25) and (2-26) are standard nonnegativity and integrality constraints for decision variables.

The TSCFLP generalizes the CFLP by considering in addition the product flows from the plants to the depots and/or the choice of the subset of plants from a set of potential plants to open. As the CFLP is NP-hard in strong sense, the TSCFLP is also NP-hard in strong sense. In the TSCFLP, each facility has a limited capacity. The volume supplied from each facility cannot exceeds its capacity. If the each facility has an unlimited capacity, the TSCFLP becomes the TSUFLP. In the TSCFLP, if each customer is assumed to be supplied from exactly one facility, it becomes the two-stage capacitated facility location problem with single source (TSCFLPSS).

Many researchers have studied the two-stage facility location problem in the literature. Geoffrion and Graves (1974) investigated a multi-commodity version of the problem and solved it using Bendres' decomposition. Hindi and Basta (1994) addressed a distribution design problem, in which customers need not be assigned to a single depot, only product flow is considered in the model. Pirkul and Jayaraman (1998) studied a similar problem as Hindi and Basta (1994). An efficient heuristic was proposed to obtain a good feasible solution. Klose (1999, 2000) considered a two-stage capacitated facility problem (TSCFLP) with single source in which the optimal depot locations, the optimal product flows and the most effective customer-depot assignments are determined. An effective linear programming-based approach (Klose, 1999) and a Lagrangean relax-and-cut approach (Klose, 2000) have been proposed for it. Ro and Tcha (1984) studied an two-level uncapacitated facility location problem with side constraints in which both the plants and warehouses are assumed as uncapacitated and the products are delivered from the plants to the customers directly with a penalty cost or indirectly via the warehouses. They proposed a branch and bound algorithm to solve their problem. Gao and Robinson (1992) dealt a two-echelon uncapacitated facility location problem and proposed a dual-based solution procedure. Tragantalerngsak et al. (1997, 2000) investigated a two-echelon capacitated facility location problem (TECFLP) with single source. Each depot (in the first echelon) has unlimited capacity and each facility (in the second echelon) has limited capacity. Each facility can be supplied exactly by only one depot. The locations of the depots and the facilities, the assignments of the customers to the facilities are determined simultaneously. Six Lagrangean relaxation heuristics

(Tragantalerngsak et al., 1997) and a branch-and-bound method based on Lagrangean relaxation (Tragantalerngsak et al., 2000) have been proposed for their problem. Hinojosa et al. (2000) studied a multiperiod two-echelon multicommodity capacitated plant location problem and designed a heuristic algorithm based on Lagrangean relaxation. For more details, we refer readers to Aardal (1998b), Chardaire (1999), Marín and Pelegrín (1999) and a systematic survey of Klose and Drexler (2005).

2.1.3 Facility location problem with facility size selection or nonlinear variable cost

Facility location problems which consider simultaneously the optimizing of the location and size of facility or nonlinear variable cost in the context of single-stage supply chain network system are rare in the literature. Lee (1993) investigated a multi-products CFLP with facility type choice. The costs considered in this problem include the fixed facility opening costs, the producing costs and the transportation costs. A cross decomposition algorithm was proposed for its solution. Mazzola and Neebe (1999) dealt with the same problem and developed a Lagrangean-based heuristic. Holmberg and Ling (1997) studied a facility location problem with choice of facility size and staircase production cost. Taniguchi et al. (1999) optimized the size and location of public logistics terminals. Queuing theory and nonlinear programming techniques were used to determine the best solution for their problem. Harkness and ReVelle (2003) addressed a facility location problem in which unit production cost is proportional to the scale of output. Four different formulations for the problem were proposed and tested by using a branch-and-bound algorithm. Wu et al. (2006) considered a capacitated facility location problem with general non-linear setup cost. A Lagrangean heuristic algorithm was developed to find near optimal solutions. Dupont (2008) investigated a facility location problem in which the total cost for each opened facility is a concave function of the quantity delivered by this facility. A branch and bound method based on the problem properties was proposed. Carrizosa et al. (2012) studied a nonlinear minsum facility location problem. The objective is to minimize the total cost including the facility opening cost that is an increasing nonlinear function of the opened facility number, and the transportation cost. Two Lagrangean relaxation approaches were proposed to solve their problem.

2.2 Lagrangean relaxation and subgradient optimization

Lagrangian relaxation is one of the most widely used techniques in solving combinatorial optimization problems. A Lagrangian relaxation of a constrained optimization problem is created by removing (relaxing) a set of constraints from the problem and placing them in the objective function weighted by penalty parameters or Lagrangian multipliers. The aim is to obtain a Lagrangian relaxation which is easier to solve than the original problem because some special structure in the remaining constraints can be exploited. An optimal objective value of the Lagrangian relaxation problem for a given set of multipliers provides a lower

bound (in the case of minimization) for the optimal solution to the original problem. The best lower bound can be derived by choosing the multipliers to be the solution of the Lagrangian dual of the original problem. An upper bound on the optimal solution of the original problem can be derived by using the information obtained from the Lagrangian relaxation to construct a feasible solution to the original problem. This is normally done by applying some heuristic. Details and applications of Lagrangian relaxation can be found in e.g., Fisher (1981) and Geoffrion (1974). Lagrangian relaxation have been widely applied to the facility location problems, e.g., Geoffrion and McBride (1978), Galvão and Raggi (1989) for uncapacitated facility location problem; Beasley (1988, 1993) for capacitated facility location problem; Barcelo and Casanovas (1984), Klincewicz and Luss (1986), Pirkul (1987), Sridharan (1993) and Beasley (1993) for single-source capacitated facility location problem.

2.2.1 Lagrangean relaxation

In order to illustrate the concept of Lagrangean relaxation, consider the following general integer program in matrix form:

$$P \quad \min \mathbf{c}\mathbf{x} \tag{2-38}$$

$$s.t. \quad \mathbf{A}\mathbf{x} = \mathbf{b} \tag{2-39}$$

$$\mathbf{D}\mathbf{x} \leq \mathbf{e} \tag{2-40}$$

$$\mathbf{x} \in \{0,1\} \tag{2-41}$$

A lower bound for the above program can be found by introducing a Lagrange multiplier vector $\mathbf{u} = (u_1, \dots, u_m)$ for the first constraint sets to get the Lagrangean lower bound program or Lagrangean relaxation. The Lagrangean relaxation $LR(\mathbf{u})$ is given by:

$$LR(\mathbf{u}) \quad \min \mathbf{c}\mathbf{x} - (\mathbf{A}\mathbf{x} - \mathbf{b}) \tag{2-42}$$

$$s.t. \quad \mathbf{D}\mathbf{x} \leq \mathbf{e} \tag{2-43}$$

$$\mathbf{x} \in \{0,1\} \tag{2-44}$$

The Lagrangean dual problem $Z_D(\mathbf{u})$ is defined to be

$$Z_D(\mathbf{u}) \quad \max_{\mathbf{u}} LR(\mathbf{u}) \tag{2-45}$$

For given Lagrangean multiplier \mathbf{u} , it is clear that $LR(\mathbf{u})$ can be easily solved to give a solution $\bar{\mathbf{x}}$ with a corresponding lower bound given by $\mathbf{c}\bar{\mathbf{x}} - \mathbf{u}(\mathbf{A}\bar{\mathbf{x}} - \mathbf{b})$.

The aim of the Lagrangean relaxation is to obtain a Lagrangean relaxation program which is easier to solve than the original problem because some special structure in the remaining constraints can be exploited. The selection of a suitable relaxation is one of the important issues to be considered when forming a solution method based on Lagrangean relaxation. Two key factors in the evaluation of a relaxation are its ease of solution and the tightness of the bounds generated. The ease of solution depends on the methods available for solving the Lagrangean subproblem. The possibility of generating such smaller and easier problems, as compared to the original problem, depends on the structure of the original problem and the degree of separability obtained by relaxing certain constraints. Generally, a relaxation which gives a tighter bound will

use greater computation time, whereas an easily solved relaxation problem is likely to give poor bounds (Geoffrion and McBride, 1978).

The main property of the dual problem $Z_D(\mathbf{u})$ is that the dual function is always concave so any local optimal solution is also a global one (Bazaraa and Sherali, 1981). The constraints are just non-negativity constraints on the Lagrangian multipliers (or dual variables) associated with the inequality constraints. In the case of an integer formulation, we also have that the dual function is non-differentiable so standard ascent methods based on gradients cannot be used for its solution. Hence we need to adopt methods that can take the non-differentiability into account. There are a number of such methods available, e.g., subgradient optimization, steepest ascent and improved subgradient (Camerini et al. 1975). The most commonly used is the subgradient optimization method and it is employed in Chapter 3-5 in this thesis due to its ease of programming.

2.2.2 Subgradient optimization

The subgradient optimization method solves a non-differentiable problem by taking a fixed step length in the direction of a subgradient. A line search cannot be done because a subgradient direction may not necessarily be an ascent direction. Convergence to an optimal dual solution can however be guaranteed by imposing restrictions on the selection of step lengths. We can easily find a subgradient since it is just the evaluation of the constraint values in the current dual solution. The details of this method can be found in Held et al. (1974). The subgradient optimization method is given in Algorithm 2.1.

Let BLB be the best lower bound found so far on the optimal objective function, BUB be the best upper bound found so far on the optimal objective function, l be an iteration counter, L_{Max} be the maximum iteration number, ε be a small scalar and λ be the step length parameter at iteration l .

Algorithm 2.1: Subgradient optimization procedure

- Step 1: Initialize \mathbf{u} , ε , L_{Max} and λ_0 , where λ_0 is a parameter in the interval $(0, 1]$. Set $BUB := +\infty$, $BLB := -\infty$, $\lambda := \lambda_0$ and $l := 0$.
- Step 2: Solve the Lagrangean relaxation problem problems $LR(\mathbf{u})$ to optimality to give the solution x . Let LB be the objective value of this solution. If $LB > BLB$, then set $BLB := LB$. If no improvement of BLB can be detected in a fixed successive iterations, then set $\lambda := \lambda/2$.
- Step 3: Find a feasible solution by applying a heuristic taking into account of the Lagrangean relaxation solution. Let UB be the objective value of the feasible solution. If $UB < BUB$, then set $BUB := UB$.
- Step 4: If $l > L_{Max}$ and $\lambda < \varepsilon$, stop. The dual solution corresponding to the BLB is regarded as the optimal dual solution and the solution corresponding to the BUB is regarded as the optimal primal solution.
- Step 5: Compute a subgradient as $\mathbf{g}^l = (\mathbf{A}\mathbf{x}^l - \mathbf{b})$, compute a step size as $S^l = \lambda (BUB - LB) / (\mathbf{g}^l)^2$, where LB is the objective value of the optimal solution to $LR(\mathbf{u}^l)$. Set $\mathbf{u}^{l+1} = \mathbf{u}^l + S^l \mathbf{g}^l$.
- Step 6: Set $l := l + 1$ and return to Step 2.
-

2.3 Metaheuristics

Metaheuristics have been a powerful solution method to many combinatorial optimization problems. In this section, we briefly introduce the principle of the tabu search (TS), variable neighborhood search (VNS) and simulated annealing (SA). The TS is used to improve the solution to the TECFLP-PSS in Chapter 3, the hybridization of the VNS and TS is used to improve the solution to the TECFLP-DSS in Chapter 4 and the hybridization of the SA and TS is used to improve the solution to the TECFLP-PDSS in Chapter 5.

2.3.1 Tabu search

Tabu search (TS), introduced by Glover (1986), is an iterative meta-heuristic that guides a local search heuristic procedure to explore the solution space beyond local optimality. In each iteration, the TS generates a neighborhood solution by an operation called move. The TS guides the search process from the current solution to its best admissible solution in its neighborhood, even if this new solution is worse than the current one. This is unlike classical descent methods in which only moves lead to improved objective function values are permitted. The TS uses a memory mechanism that prevents the search from cycling back to previously visited solutions. The memory mechanism that maintains the search history is called the tabu list. The tabu list keeps either some of the moves or just their attributes, and reversing these moves is forbidden for a given number of iterations. However, this restriction can be ignored if the attempted move leads to a new globally optimal solution, this is called the aspiration criterion. This criterion allows for exceptions from the tabu list, if any move leads to promising solution. The TS terminates when stopping criteria are satisfied, for example, it stops after a fixed number of iterations or a maximum number of consecutive iterations without any improvement to the incumbent (best known) solution. The principal steps of the TS algorithm are shown in Fig. 2.3. For more details of TS, we refer readers to Glover (1986, 1989, 1990).

Initialize tabu list TL , generate a solution \mathbf{x} , set $\mathbf{x}^{\text{best}} = \mathbf{x}$.

While stopping criteria are not met **do**

 Find a solution \mathbf{x}' in the neighbourhood of \mathbf{x} applying a search strategy

If $f(\mathbf{x}') < f(\mathbf{x}^{\text{best}})$ or \mathbf{x}' is not tabu **then**

$\mathbf{x} = \mathbf{x}'$, update the tabu list TL

End if

If $f(\mathbf{x}) < f(\mathbf{x}^{\text{best}})$ **then**

$\mathbf{x}^{\text{best}} = \mathbf{x}$

End if

End while

Fig. 2.3 The principal steps of the TS algorithm

The feature of the TS is that a flexible memory structure and aspiration criteria are systematically used to guide its search. Moreover, due to the acceptance of deteriorated solutions in the search process, the TS can ‘jump’ from local optimum to other region of the solution space so that the probability to find an global

optimal solution is enhanced. The new solution is not randomly generated in the neighborhood of the current solution, it is the one which is better than the best current solution, or the best admissible solution which is not tabu. The best admissible solution is selected from the neighborhood of the current solution according to some pre-given rules.

In Chapter 3, we use a TS algorithm based on problem properties to further improve the best upper bound found in the Lagrangean relaxation approach for the TECFLP-PSS as this metaheuristic has so far proved to be successful in solving a variety of hard combinatorial problems. To the best of our knowledge, this is the first time a TS heuristic is implemented for the two-stage facility location problem.

2.3.2 Variable neighborhood search

Variable neighborhood search (VNS), introduced by Mladenović and Hansen (1997), is a generic local search methodology, whose basic idea is to apply a systematic change of neighborhoods within a local search algorithm. The VNS combines a descent phase, to find a local minimum, and a perturbation phase, to escape from the corresponding local minimum. Given a set of pre-selected neighborhood structures, the VNS starts from an initial solution, a random solution is generated in the first neighborhood of the current solution, from which a local descent is performed. If the local optimum obtained is not better than the incumbent, then the procedure is repeated with the next neighborhood. The search restarts from the first neighborhood when either a solution which is better than the incumbent has been found or every neighborhood structure has been explored or other stopping criteria are met. The principal steps of the basic VNS algorithm (BVNS) are shown in Fig. 2.4.

The idea of the VNS is based on the following observations: 1) a local minimum with respect to one neighborhood structure is not necessary so for another, 2) a global minimum is a local minimum with respect to all possible neighborhood structures, 3) for many problems local minima with respect to one or several neighborhoods are relatively close to each other. Unlike many other metaheuristics, the basic schemes of VNS and its extensions are simple and require few, and sometimes no parameters.

A popular variant is the deterministic Variable Neighborhood Descent (VND) where the best neighbor of the current solution is considered instead of a random one. Also, no local descent is performed with this neighbor. Rather, it automatically becomes the new current solution if an improvement is obtained, and the search is then restarted from the first neighborhood. Otherwise, the next neighborhood is considered. The search stops when all neighborhood structures have been considered and no improvement is possible. At this point, the solution is a local optimum for all neighborhood structures. For more details of VNS we refer readers to the surveys of Hansen and Mladenović (2001).

Generate a solution \mathbf{x} , set $\mathbf{x}^{\text{best}} = \mathbf{x}$, define the neighborhood structures $N_l(\mathbf{x})$, $l = 1, \dots, L_{\text{max}}$, choose a stopping criteria, $l = 1$.

While $l \leq L_{\text{max}}$ and stopping criteria are not met **do**

Shaking. Generate a solution \mathbf{x}' at random from the l^{th} neighbourhood $N_l(\mathbf{x})$ of \mathbf{x} .

Local search. Apply some local search method with \mathbf{x}' as an initial solution, denote with \mathbf{x}'' the so obtained local optimal.

Move or not. **If** $f(\mathbf{x}'') < f(\mathbf{x}^{\text{best}})$ **then**

$\mathbf{x} = \mathbf{x}'', l = 1.$

else

$l = l + 1.$

End if

End while

Fig. 2.4 The principal steps of the basic VNS algorithm

Although the VNS has so far proved to be successful in solving a variety of hard combinatorial problems. The basic VNS sometimes meets difficulties to escape from the local optimum although it explores solution space by applying a systematic change of neighborhoods and moves randomly from one solution to another (shaking). On the other hand, the TS has no such difficulties since it escapes the local optimum by using a tabu list to avoid the recently visited solutions being revisited. To make use of the potentiality of the systematic changes of the neighborhood structures of the VNS and the efficiency of the TS to escape from a local optimum, the hybrid of the VNS and the TS has been applied in many combinatorial optimization problems, such as vehicle routing problem (Belhaiza et al., 2014) and location routing problem (Escobar et al., 2014).

In Chapter 4, we proposed a hybrid variable neighborhood tabu search algorithm (HVNTS) to further improve the best upper bound found in the Lagrangean relaxation approach for the TECFLP-DSS. In the proposed HVNTS, we follow the framework of the VNS and use the TS as the local search within the VNS framework. To the best of our knowledge, the combination of the VNS and TS is rare in the literature and never been used for the solution for facility location problem. Thus it is the first time that the hybridization of the VNS and TS heuristic is implemented for the facility location problem.

2.3.3 Simulated annealing

Simulated annealing (SA) is a stochastic method for solving combinatorial problems that was proposed by Kirkpatrick et al. (1983). The SA methodology draws its inspiration from the annealing process in metallurgy. SA works by emulating the physical process in which a solid is heated to a high temperature and cooled step-by-step to allow the solid to crystallize. The SA uses a stochastic approach to guide the search. In addition to accepting better solutions, The SA allows the search to proceed to a neighboring state even if the move causes the value of the objective function to become worse. The SA explores the solution space in the following way. If a move to a neighbor \mathbf{x}' in a neighborhood ensures an improvement in the objective value or leaves the value unchanged, then the move is always accepted. More precisely, the solution \mathbf{x}' is accepted as the new solution if $\Delta \leq 0$, where $\Delta = f(\mathbf{x}') - f(\mathbf{x})$. Moves that increase the objective function (i.e., $\Delta > 0$) are accepted according to a probability function $e^{-\Delta/T} > \gamma$, where T is the temperature parameter and γ is a random number between $[0, 1]$. The value of T varies from a relatively large number to a value close to

zero, T is often controlled by linear equations to reduce the temperature linearly with a rate a . The principal steps of the SA algorithm are shown in Fig. 2.5.

Generate a solution \mathbf{x} , set $\mathbf{x}^{\text{best}} = \mathbf{x}$, initialize the temperature T and cooling parameter a , choose a stopping criteria.

While stopping criteria are not met **do**

 Generate a solution \mathbf{x}' at random from \mathbf{x} by using a local search method.

If $f(\mathbf{x}') < f(\mathbf{x}^{\text{best}})$ **then**

$\mathbf{x} = \mathbf{x}'$.

else

$\Delta = f(\mathbf{x}') - f(\mathbf{x})$.

If $\exp(-\Delta / T) > \text{random}[0, 1]$ **then**

$\mathbf{x} = \mathbf{x}'$.

End if

End if

$T = T \times a$

If $f(\mathbf{x}) < f(\mathbf{x}^{\text{best}})$ **then**

$\mathbf{x}^{\text{best}} = \mathbf{x}$.

End if

End while

Fig. 2.5 The principal steps of the SA algorithm

The SA algorithm with all its advantages also has some demerits, such as it requires large number of iterations to generate an optimal or near optimal solution. In addition, the SA has no concept of short-term memory list of prohibited neighboring solutions as in tabu search algorithm and hence the possibility of revisiting the solution increased. These two drawbacks posed by the SA leads to more number of iteration and thus longer computational time to generate the global optima solution.

The stochastic characteristic of the SA avoids cycling but the rate of improvement of solution is very slow, because it has no memory of the recently visited solutions. So it is always possible for the SA search to return to the same solution again. However, with the help of a short-term memory, the search of the SA can be restricted from looping back to previously visited solutions and the performance of the SA can be enhanced significantly. Keeping the above ideas in mind, the hybridization of the SA and TS has been applied in many combinatorial optimization problems in the literature, such as the capacitated clustering problem (Osman and Christofides, 1994), modeling machine loading problem (Swarnkar and Tiwari, 2004) and vehicle routing problem (Küçükoğlu and Öztürk, 2015).

In Chapter 5, we design a hybrid simulated annealing tabu search algorithm (HSATS) for the TECFLP-PDSS. The HSATS takes advantages of the stochastic feature of the SA to escape from local optima and the short term memory strategy of the TS to avoid cycling. To the best of our knowledge, the combination of the SA and TS is also rare in the literature and never been used for the solution for facility location problem.

Thus it is the first time that the hybridization of the SA and TS heuristic is implemented for the facility location problem.

Chapter 3

Two-echelon capacitated facility location problem with plant size selection

3.1 Introduction

The traditional two-stage facility location problem focus on determining the locations of plants and depots, and the flows of product from plants to customers via depots with the goal of minimizing the sum of facility opening costs and logistic costs. In these problems, each plant has only one choice of capacity, either uncapacitated or capacitated. The opening cost of a plant is a constant and the unit production cost is the same for all of the plants, thus it can be merged with other linear connection costs. However, in some practical situations firms need also to determine the sizes of plants in designing a two-stage supply chain network. The size of plant greatly affects not only its fixed opening cost, but also the unit producing cost due to economies of scale. How to make a trade-off between plant location and size is a significant problem in supply chain network design. Thus we study a two-echelon capacitated facility location problem with plant size selection (TECFLP-PSS) in this chapter. This is an extension of the TSCFLP. In this problem we simultaneously locate plants and depots, and select sizes for the located plants, where each plants in the first stage has several potential sizes exhibiting different capacities. Each depot in the second stage has a limited capacity and is supplied by multiple plants. Each customer in the third stage is serviced by only one depot. This extended model can then simultaneously determine the locations and sizes of the plants, the locations of the depots, the product flows from the plants to the depots and the assignments of the customers to the depots to satisfy the customers' demands.

As it is well known the fixed opening cost of a facility depends on the size of the facility opened. It is not realistic to expect that different size of a facility at the same site have the same fixed opening cost. In addition, the unit production cost generally decreasing with increasing scale as fixed costs are spread out over more units of output. Operational efficiency is also greater with increasing scale, leading to lower unit production cost as well. Therefore, in the TECFLP-PSS, the fixed opening costs are assumed to be different for different sizes of a plant, i.e., the fixed opening cost for a larger size of a plant is more than those of the smaller sizes of the same plant. The unit production cost for a larger size of a plant is less than those of the smaller sizes of the same plant to model the economies of scale. The distinguishing features of the TECFLP-PSS are: 1) there are several sizes for each potential plant that can be opened, 2) production cost is taken into account specifically since the unit production cost for a larger size of a plant is less than those of the smaller sizes of the same plant, thus it cannot be merged with other linear connection costs like it is done in the traditional facility location model.

The TECFLP-PSS is an extension of the TSCFLP. As the TSCFLP is NP-hard in strong sense, the TECFLP-PSS is also NP-hard in strong sense. Due to the NP-hardness of the TECFLP-PSS, we focus on searching for good lower and upper bounds for it. For this problem, a mixed integer linear programming model is formulated and a Lagrangean relaxation approach is proposed to achieve lower and upper bounds. To further improved the best upper bound found by the Lagrangean relaxation approach, a tabu search (TS) algorithm is proposed. To solve the dual problem arising in the Lagrangean relaxation approach, we make

use of a subgradient optimization method. The Lagrangean relaxation problem can be decomposed into two subproblems, one can be solved to optimality by inspections and another one can be decomposed further into the classical 0-1 knapsack problem which can be exactly solved in a very reasonable time by using the MINKNAP developed by Pisinger (1995). In order to construct feasible solution and find an upper bound, we design a heuristic by repairing the Lagrangean relaxation solutions. The feasible solution construction process consists of three stages: 1) open plants and select their sizes, 2) open depots and determine the customer-depot assignments, 3) determine the product flows from the plants to the depots. In the search process of the TS, the product flow cost changes between plants and depots incurred by reassignment of customers are taken into account in a heuristic way. A heuristic is proposed to adjust the product flows between plants and depots into feasible flow after reassignments of customers. After the TS, the optimal product flows are determined by solving a transportation problem using commercial solver CPLEX.

In order to evaluate the performance of the proposed Lagrangean relaxation approach and TS, 245 instances are randomly generated and tested. To evaluate the solution quality and speed of the Lagrangean relaxation approach and TS, 50 instances with different problem size are tested. The Lagrangean upper bounds are compared with the Lagrangean lower bounds and the upper bounds provided by commercial MIP solver CPLEX, and the upper bounds obtained by the TS are also compared with those of CPLEX. The results indicate that the proposed solution method is effective for the TECFLP-PSS since the gaps between the upper bounds and those of CPLEX are less than 1.66% on average and the CPU time required by the Lagrangean relaxation and TS is much less than that of CPLEX. In addition, 195 instances with different sizes and different parameters, such as the ratio of plant capacity to customer demand, the ratio of depot capacity to customer demand and the number of plant size, are randomly generated and tested. The results of the gaps between the Lagrangean upper and lower bounds, the upper bounds obtained by TS and Lagrangean lower bounds are reported. The computational results demonstrate that all of the instances can be solved in a reasonable time with small gaps, even for instances that have up to 50 potential plants with 6 possible sizes each, 200 potential depots and 400 customers.

The rest of this chapter is organized as follows. In Section 3.2, a mixed integer programming model is formulated for the TECFLP-PSS. In Section 3.3, a Lagrangean relaxation approach is proposed to achieve lower and upper bounds. In Section 3.4, a tabu search algorithm is proposed to improve the best upper bounds found by the a Lagrangean relaxation approach. In Section 3.5, we evaluate the proposed algorithms on randomly generated instances. Conclusions are drawn in Section 3.6.

3.2 Problem formulation

Given a set of potential plants, each of which has several possible sizes exhibiting different capacities, a set of potential capacitated depots and a set of customers with demands, the TECFLP-PSS is to optimally determine the locations of the plants as well as their sizes, the locations of the capacitated depots, the product flows from the plants to the depots and the customer-depot assignment under single sourcing constraints so that all of the customers' demands are satisfied. The objective is to minimize the sum of the fixed opening

3. Two-echelon capacitated facility location problem with plant size selection

costs of the plants and depots, the production costs of product and the shipping costs of product from the plants to the depots and then to the customers. The structure of the TECFLP-PSS is presented in Fig. 3.1, where the first or upper-most stage are the plants, each plant has several sizes, the second or central stage are the depots and the third stage are the customers.

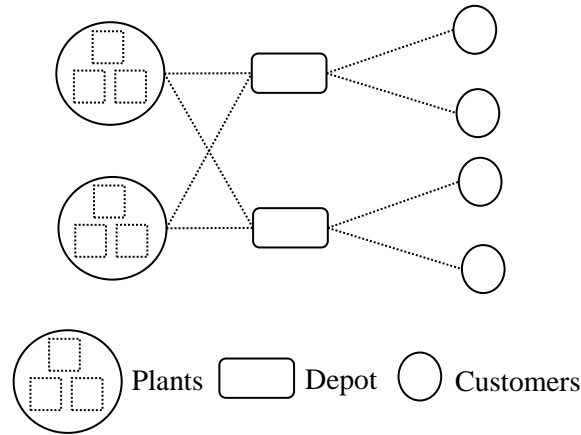

Fig. 3.1 The structure of the TECFLP-PSS

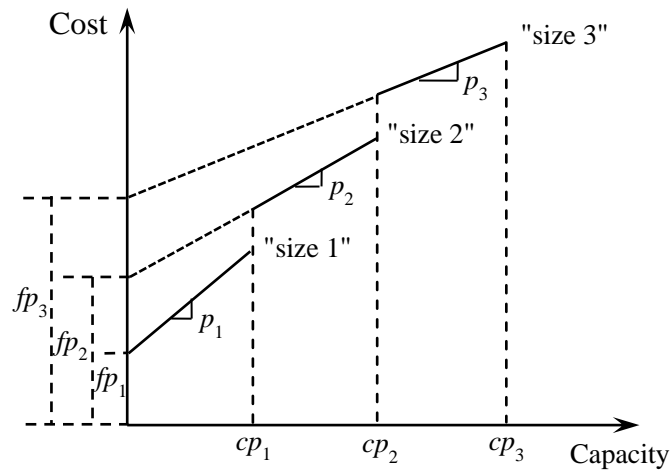

Fig 3.2. An example of the cost function of a plant

In the TECFLP-PSS, each size of a plant associates with a capacity cp , a fixed opening cost fp and a unit production cost p . The fixed opening cost for a larger size of a plant is larger than those of the smaller sizes of the same plant. To model the economies of scale, the unit production cost p for a larger size of a plant is smaller than those of the smaller sizes of the same plant. An example of the cost function including the fixed opening cost and the production cost of a plant is illustrated in Fig. 3.2.

To formulate the TECFLP-PSS, the notations and decision variables used are as follows:

Notations:

- I the set of potential plants;
- J the set of potential depots;

3. Two-echelon capacitated facility location problem with plant size selection

K	the set of customers;
R_i	the set of production sizes of the plant $i \in I$;
cp_{ir}	the capacity of the plant $i \in I$ with the production size $r \in R_i$;
cd_j	the capacity of the depot $j \in J$;
d_k	the demand of customer $k \in K$;
fp_{ir}	the fixed cost of the plant $i \in I$ with the production size $r \in R_i$;
fd_j	the fixed cost of the depot $j \in J$;
p_{ir}	the unit production cost of the plant $i \in I$ with the size $r \in R_i$;
t_{ij}	the unit transportation cost from the plant $i \in I$ to the depot $j \in J$;
c_{jk}	the cost of assigning customer $k \in K$ to the depot $j \in J$;

Decision variables:

u_{ir}	1, if the plant $i \in I$ with the production size $r \in R_i$ is opened; otherwise 0;
v_j	1, if the depot $j \in J$ is opened; otherwise 0;
x_{irj}	the quantity of product flow from the plant $i \in I$ with the size $r \in R_i$ to the depot $j \in J$;
z_{jk}	1, if a customer $k \in K$ is assigned to the depot $j \in J$;

The TECFLP-PSS can be formulated as:

$$P: \quad \min \sum_{i \in I} \sum_{r \in R_i} fp_{ir} \cdot u_{ir} + \sum_{i \in I} \sum_{r \in R_i} \sum_{j \in J} (p_{ir} + t_{ij}) \cdot x_{irj} + \sum_{j \in J} fd_j \cdot v_j + \sum_{j \in J} \sum_{k \in K} c_{jk} \cdot z_{jk} \quad (3-1)$$

$$s.t. \quad \sum_{j \in J} x_{irj} \leq cp_{ir} \cdot u_{ir} \quad \forall i \in I, \forall r \in R_i \quad (3-2)$$

$$\sum_{r \in R_i} u_{ir} \leq 1 \quad \forall i \in I \quad (3-3)$$

$$\sum_{i \in I} \sum_{r \in R_i} x_{irj} - \sum_{k \in K} d_k \cdot z_{jk} = 0 \quad \forall j \in J \quad (3-4)$$

$$\sum_{k \in K} d_k \cdot z_{jk} \leq cd_j \cdot v_j \quad \forall j \in J \quad (3-5)$$

$$\sum_{j \in J} z_{jk} = 1 \quad \forall k \in K \quad (3-6)$$

$$\sum_{j \in J} cd_j \cdot v_j \geq \sum_{k \in K} d_k \quad (3-7)$$

$$u_{ir} \in \{0, 1\} \quad \forall i \in I, \forall r \in R_i \quad (3-8)$$

$$v_j \in \{0, 1\} \quad \forall j \in J \quad (3-9)$$

$$x_{irj} \geq 0 \quad \forall i \in I, \forall r \in R_i, \forall j \in J \quad (3-10)$$

$$z_{jk} \in \{0, 1\} \quad \forall j \in J, \forall k \in K \quad (3-11)$$

The objective (3-1) minimizes the total costs of opening the plants and depots, producing and shipping the products. The constraints (3-2) ensure that the total product flows moving out from a plant cannot exceed

the capacity of its opened size. The constraints (3-3) state that only one size of an opened plant can be selected to open. The constraints (3-4) are the flow equilibrium constraints at the depots. The constraints (3-5) address that the demands assigned to an opened depot cannot exceed its capacity. The constraints (3-6) guarantee that each customer is assigned to exactly one depot. The constraint (3-7) is a redundant constraint, which specifies that the demands of all customers can be satisfied by open plants. We add it to the formulation in order to improve the Lagrangean lower bounds. The constraints (3-8), (3-9), (3-10) and (3-11) are standard nonnegativity and integrality constraints for decision variables.

As a generalization of the TSCFLP, the TECFLP-PSS is NP-hard in strong sense. Thus we focus on searching for lower and upper bounds for it, especially for those large-sized instances in a reasonable time. A Lagrangean relaxation approach and a tabu search in the following to find sub-optimal solutions.

3.3 Lagrangean relaxation approach for the TECFLP-PSS

Due to the NP-hardness of the TECFLP-PSS, we focus on searching for lower and upper bounds for it in a reasonable time. The Lagrangean relaxation approach is one of the most effective approaches for achieving lower and upper bounds for mixed integer linear programming problems, which relaxes hard constraints into the objective function by introducing Lagrangean multipliers. This approach has been widely applied for various facility location problems, e.g., Geoffrion and McBride (1978) for the CFLP, Klincewicz and Luss (1986) for the SSCFLP, Klose (2000) for the TSCFLP and Tragantalerngsak et al. (1997) for a two-echelon, single-source, capacitated facility location problem. Due to the effectiveness of the Lagrangean relaxation approach, it is used here to achieve lower and upper bounds of the TECFLP-PSS. The Lagrangean relaxation approach is presented as follows.

3.3.1 Lagrangean relaxation model of the TECFLP-PSS

The selection of a suitable relaxation is very important for generating good lower and upper bounds. For the TECFLP-PSS, the constraints (3-4) and (3-6) or (3-2) and (3-6) can be relaxed to generate two different Lagrangean relaxation problems. In our implementation, the constraints (3-2) and (3-6) are relaxed by introducing the non-negative multipliers α_{ir} ($i \in I, r \in R_i$) and the multipliers β_k ($k \in K$) since it can generate better lower and upper bounds than relaxing the constraints (3-4) and (3-6) based on our preliminary experiments. Relaxing the constraints (3-2) and (3-6) with the non-negative multipliers α_{ir} ($i \in I, r \in R_i$) and β_k ($k \in K$) respectively, the Lagrangean relaxation problem $LR(\alpha, \beta)$ is therefore

$$LR(\alpha, \beta) = \min \sum_{i \in I} \sum_{r \in R_i} (fp_{ir} - \alpha_{ir}) \cdot u_{ir} + \sum_{k \in K} \beta_k + \sum_{i \in I} \sum_{r \in R_i} \sum_{j \in J} (p_{ir} + t_{ij} + \alpha_{ir}/cp_{ir}) \cdot x_{irj} + \sum_{j \in J} fd_j \cdot v_j + \sum_{j \in J} \sum_{k \in K} (c_{jk} \cdot d_k - \beta_k) \cdot z_{jk} \quad (3-12)$$

3. Two-echelon capacitated facility location problem with plant size selection

s.t. (3-3)-(3-5) and (3-7)-(3-11).

The $LR(\alpha, \beta)$ can be divided into two independent subproblems $LR_1(\alpha)$ and $LR_2(\alpha, \beta)$.

The first subproblem $LR_1(\alpha)$ is

$$LR_1(\alpha) = \min \sum_{i \in I} \sum_{r \in R_i} (fp_{ir} - \alpha_{ir}) \cdot u_{ir} \quad (3-13)$$

s.t. (3-3) and (3-8),

which can be solved exactly in $O(|I| \cdot |R_i|)$ by setting a maximum of one u_{ir} to 1, with the smallest negative $fp_{ir} - \alpha_{ir}$ value for each $i \in I$.

The second subproblem $LR_2(\alpha, \beta)$ is

$$LR_2(\alpha, \beta) = \min \sum_{i \in I} \sum_{r \in R_i} \sum_{j \in J} (p_{ir} + t_{ij} + \alpha_{ir}/cp_{ir}) \cdot x_{irj} + \sum_{j \in J} fd_j \cdot v_j \\ + \sum_{j \in J} \sum_{k \in K} (c_{jk} \cdot d_k - \beta_k) \cdot z_{jk} \quad (3-14)$$

s.t. (3-4), (3-5), (3-7) and (3-9)-(3-11).

In the $LR_2(\alpha, \beta)$, the variables x_{irj} and z_{jk} are connected only by the constraints (3-4). It can be observed that there always exists an optimal solution of the $LR_2(\alpha, \beta)$ where a depot j is only supplied by its 'cheapest source'. For any $i \in I$, $r \in R_i$, $j \in J$, set

$$x_{irj} = \begin{cases} \sum_{k \in K} d_k \cdot z_{jk}, \{i, r\} = \arg \min_{m \in I, n \in R_i} (p_{nm} + t_{mj} + \alpha_{nm}/cp_{nm}), \\ 0, \text{otherwise} \end{cases}$$

The $LR_2(\alpha, \beta)$ can be reduced to

$$LR'_2(\alpha, \beta) = \min \sum_{j \in J} fd_j \cdot v_j + \sum_{j \in J} \sum_{k \in K} (c_{jk} \cdot d_k + w_j \cdot d_k - \beta_k) \cdot z_{jk} \quad (3-15)$$

s.t. (3-5), (3-7), (3-9) and (3-11),

where $w_j = \min_{i \in I, r \in R_i} (p_{ir} + t_{ij} + \alpha_{ir}/cp_{ir})$.

For each j , let fd'_j be the optimal objective value of the problem

$$\min \sum_{k \in K} (c_{jk} \cdot d_k + w_j \cdot d_k - \beta_k) \cdot z_{jk} + fd_j \quad (3-16)$$

$$s.t. \quad \sum_{k \in K} d_k \cdot z_{jk} \leq cd_j \quad (3-17)$$

$$z_{jk} \in \{0, 1\} \forall k \in K \quad (3-18)$$

This problem is a 0-1 knapsack problems, which can be exactly solved in a very reasonable time by using the MINKNAP developed by Pisinger (1995).

Then the $LR'_2(\alpha, \beta)$ can be reformulated as:

$$LR_2'(\alpha, \beta) = \min \sum_{j \in J} fd'_j \cdot v_j \quad (3-19)$$

s.t.(3-5), (3-7) and (3-9),

which can be transformed into a classical 0-1 knapsack problem. Let $y_j = 1 - v_j, \forall j \in J$, the transformed problem is presented in the following.

$$P_{knapsack} = \max \sum_{j \in J} fd'_j \cdot y_j - \sum_{j \in J} fd'_j \quad (3-20)$$

$$s.t. \sum_{j \in J} cd_j \cdot y_j \leq \sum_{j \in J} cd_j - \sum_{k \in K} d_k \quad (3-21)$$

$$y_j \in \{0, 1\} \forall j \in J \quad (3-22)$$

where fd'_j is viewed as the profit of the item $j \in J$, cd_j as the weight of item $j \in J$, and $\sum_{j \in J} cd_j - \sum_{k \in K} d_k$ as the capacity of the knapsack. We simply set $y_j = 0$ where $fd'_j \leq 0$, because the profit of those items are non-positive. This problem can also be solved exactly by using the MINKNAP developed by Pisinger (1995).

Let $LB(\alpha, \beta)$ be the sum of the objective value of the solution of $LR_1(\alpha)$, $LR_2'(\alpha, \beta)$ and $\sum_{k \in K} \beta_k$.

Obviously, $LB(\alpha, \beta)$ is a lower bound of the TECFLP-PSS for given Lagrangean multipliers (α, β) .

3.3.2 Subgradient optimization for the TECFLP-PSS

To obtain the best Lagrangean lower bound of the TECFLP-PSS, a subgradient optimization method is adopted to approximately solve the corresponding Lagrangean dual problem.

$$D : \max_{\alpha \geq 0, \beta} LR(\alpha, \beta) \quad (3-23)$$

The subgradient optimization is an iterative process that repeatedly solves the Lagrangean relaxation problem and then updates the Lagrange multipliers for the next iteration by using the current subgradient information.

Let $(\hat{u}^l, \hat{x}^l, \hat{v}^l, \hat{z}^l)$ be the optimal solution of $LR(\alpha^l, \beta^l)$ at iteration l . Let $\gamma_{ir}^l = \sum_{j \in J} \hat{x}_{irj}^l - cp_{ir} \cdot \hat{u}_{ir}^l, \forall i \in I$,

$r \in R_i$ and $\eta_k^l = 1 - \sum_{j \in J} \hat{z}_{jk}^l, \forall k \in K$, the Lagrangean multipliers for the iteration $l+1$ are updated by

$$\alpha_{ir}^{l+1} = \max\{\alpha_{ir}^l + \theta^l \cdot \gamma_{ir}^l, 0\} \quad (3-24)$$

$$\beta_k^{l+1} = \beta_k^l + \theta^l \cdot \eta_k^l \quad (3-25)$$

where $\theta^l = \lambda \cdot (BUB - LB(\alpha^l, \beta^l)) / (\sum_{i \in I} \sum_{r \in R_i} (\gamma_{ir}^l)^2 + \sum_{k \in K} (\eta_k^l)^2)$ is the step size at iteration l , BUB is the best upper

bound of the TECFLP-PSS found in the previous $l - 1$, $LB(\alpha^l, \beta^l)$ is the lower bound of the TECFLP-PSS (see subchapter 3.3.1) at iteration l , λ is a parameter in the interval $(0, 2]$, which is halved if the best lower

bound hasn't been improved for a given number N_{lag} of consecutive iterations.

Let BLB be the best lower bound found in previous $l - 1$ iterations, L_{Lag} be the maximum number of iterations and ε_{Lag} be a positive small scalar. Then the subgradient optimization procedure for the TECFLP-PSS is described in detail in Algorithm 3.1.

Algorithm 3.1: Subgradient optimization procedure for the TECFLP-PSS

Step 1: Initialize N_{lag} , L_{Lag} , ε_{Lag} and λ_0 , where λ_0 is a parameter in the interval $(0, 2]$. Set $BUB := +\infty$,

$$BLB := -\infty, \alpha_{ir}^0 := 0, \forall i \in I, r \in R_i, \beta_k^0 := 0, \forall k \in K, \lambda := \lambda_0 \text{ and } l := 1.$$

Step 2: Solve the subproblems $LR_1(\alpha^l)$ and $LR_2(\alpha^l, \beta^l)$ to optimality. Let $LB = LB(\alpha^l, \beta^l)$. If $LB > BLB$, then set $BLB := LB$. If no improvement of BLB can be detected in N_{lag} successive iterations, then set $\lambda := \lambda/2$.

Step 3: Construct a feasible solution of TECFLP-PSS based on the current Lagrangean relaxation solution (Chapter 3.3.3). Let UB be the objective value of this solution. If $UB < BUB$, then set $BUB := UB$.

Step 4: If $l > L_{\text{Lag}}$ and $\lambda < \varepsilon_{\text{Lag}}$, stop. The dual solution corresponding to the BLB is regarded as the optimal dual solution and the solution corresponding to the BUB is regarded as the optimal primal solution.

Step 5: Update α_{ir}^l for $\forall i \in I, r \in R_i$ and β_k^l for $\forall k \in K$ according to the formula (3-24) and (3-25) respectively.

Step 6: Set $l := l + 1$ and return to Step 2.

Note that as the iterations move on, the value of parameter λ becomes smaller and smaller until the lower bound $LB(\alpha^l, \beta^l)$ becomes stable, and no further improvement of BLB can be achieved. To escape this 'dilemma', we restart the subgradient optimization procedure by means of initializing the BUB and the BLB with the best values obtained in the previous subgradient process. Also, the Lagrangean multipliers are initialized to the multipliers that lead to the BLB . Starting from a relatively good initial point and resetting parameter λ , we hope that the subgradient process can increase the probability of obtaining better lower and upper bounds.

3.3.3 Feasible solution construction

At each iteration of the subgradient optimization process, i.e., at iteration l , we repair the Lagrangean relaxation solution to obtain a feasible solution of the TECFLP-PSS. The feasible solution construction process can be divided into the following three stages: 1) open plants and select their sizes, 2) open depots and determine the customer-depot assignments, 3) determine the product flows from the plants to the depots.

1) Open plants and select their sizes

We first open the plants \bar{i} with size \bar{r} , where $(\bar{i}, \bar{r}) \in \{(i, r) | \hat{u}_{ir}^l = 1, \forall i \in I, r \in R_i\}$ and denote these opened plants as \bar{I} . If the sum of capacities of the opened plants can cover all of the customers' demands, the

3. Two-echelon capacitated facility location problem with plant size selection

locations of the plants and their sizes are determined. Otherwise, we consider to open more plants and select their sizes, or we select larger sizes for the currently opened plants.

Defined $FP_{ir}^l = fp_{ir}^l - \alpha_{ir}^l$, $i \in I$, $r \in R_i$ as the evaluation cost of opening a plant at site i with size s in $LR_1(\alpha^l)$. Let ΔFP_{ir}^l and ΔCP_{ir}^l be the variations of cost and capacity, respectively, if plant status is changed. ΔFP_{ir}^l is calculated as $FP_{ir}^l - FP_{i\bar{r}}^l$, if plant i is opened with size \bar{r} , FP_{ir}^l otherwise. ΔCP_{ir}^l is calculated as $cp_{i\bar{r}} - cp_{ir}$ if plant i is opened with size \bar{r} , cp_{ir} otherwise. For an opened plant, we only consider the sizes that are greater than the currently chosen sizes. The main idea of the proposed construction method is to iteratively open a new plant or to change the size of an opened plant until all of the customers' demands are covered. At each iteration, we open a plant i and choose a size r with the smallest value of $\Delta FP_{ir}^l / \Delta CP_{ir}^l$. For a previously opened plant, if its size is changed we only preserve the latest size (as only size of a plat can be selected). The detailed procedure for opening plants and selecting sizes is summarised in Algorithm 3.2.

Algorithm 3.2: Opening plants and selecting sizes

Step 1: Open all of the plants i with the size r if $u_{ir} = 1$ in the Lagrangean relaxation solution and denote these plants as \bar{I} .

Step 2: If the total capacity of the opened plants is equal to or greater than the total customers' demands, return the opened plants and their sizes, stop.

Step 3: If the total capacity of the opened plants is less than the total customers' demands, repeat Steps 3.1-3.2 until all of the customers' demands are covered.

Step 3.1: For each potential plant and possible size, compute the ΔFP_{ir}^l and ΔCP_{ir}^l .

Step 3.2: Open the plant i and select the size r for this plant if it has the smallest $\Delta FP_{ir}^l / \Delta CP_{ir}^l$ value and add it into \bar{I} . Preserve the size r for the plant i if it has been previously opened.

2) Open depots and determine the customer-depot assignments

The Lagrangean relaxation solution may be infeasible for the original problem. To open depots and determine the customer-depot assignments, we repair the Lagrangean relaxation solution to a feasible solution so that each customer is assigned to exactly one depot.

First, we open all of the depots where $\hat{v}_j^l = 1$ in the Lagrangean relaxation solution and denote these depots as \bar{J} , that is $\bar{J} = \{j \in J / \hat{v}_j^l = 1\}$.

Based on the customer-depot assignments in the Lagrangean relaxation solution, we partition the set K of customers into three mutually disjoint subsets:

$$K_0 = \{k \in K : \sum_{j \in J} \hat{z}_{jk}^l = 0\}$$

$$K_1 = \{k \in K : \sum_{j \in J} \hat{z}_{jk}^l = 1\} \text{ and}$$

$$K_2 = \{k \in K : \sum_{j \in J} \hat{z}_{jk}^l \geq 1\},$$

such that $K_0 \cup K_1 \cup K_2 = K$.

Second, we assign the customers of K_1 to the depot j where $\hat{z}_{jk}^l = 1$. The customers of K_2 are assigned to the depot j where $\hat{z}_{jk}^l = 1$ and c_{jk} is the smallest.

Third, we assign the customers of K_0 to depots one by one based on a regret value. Define φ_{jk} as the evaluation cost of assigning customer k to a depot j , which is equal to c_{jk} if depot j is currently opened, and otherwise $c_{jk} + fd_j \cdot d_k / cd_j$. This definition takes the fixed opening cost of the depot into account. The regret value of a customer k is defined as the difference between the second smallest and the smallest φ_{jk} values among all of the depots whose residual capacities are greater than d_k . If a customer k has only one candidate depot, then we give a high regret value to that customer. At each step, the customer with the largest regret value is assigned to the depot where φ_{jk} value is the smallest. A depot j that is not currently in \bar{J} will be opened and added to \bar{J} if a customer is assigned to it.

Finally, we close those depots to which no customer is assigned and delete them from the set \bar{J} .

The procedure for opening depots and determining the assignments of the customers is shown in Algorithm 3.3.

Algorithm 3.3: Opening depots and determining the customer-depot assignments

Step 1: Add depots j with solution $\hat{v}_j^l = 1$ to set \bar{J} .

Step 2: Assign the customers in set K_1 to the depot j where $\hat{z}_{jk}^l = 1$. Assign the customers in set K_2 to the depot j where $\hat{z}_{jk}^l = 1$ and c_{jk} is the smallest.

Step 3: If some customers are not assigned, repeat Steps 3.1 to 3.3 until all of the unassigned customers are assigned, or we find an unassigned customer can not be assigned to any depot with sufficient residual capacity.

Step 3.1: Compute the costs φ_{jk} and regret values for all of the unassigned customers.

Step 3.2: Choose the unassigned customer with the maximum regret value.

Step 3.3: Assign the chosen customer to the depot with the smallest φ_{jk} . If a customer is assigned to a depot that is not in set \bar{J} , add this depot to the set \bar{J} .

Step 4: Close the depots to which no customers assigned and delete these depots from set \bar{J} .

3) Determine the product flows from the plants to the depots

If plants with enough capacity have been opened by using Algorithm 3.2 and if feasible customer-depot assignments have been obtained by Algorithm 3.3, then the product flow from the plants to the depots can be determined by solving a transportation problem. In this transportation problem, the opened plants and depots

are viewed as the source nodes and the destination nodes respectively, the plants capacities and the customers' demands assigned to the depots are viewed as the supply capacities and destination demands respectively. After solving the transportation problem, we close all of the opened plants whose products are not flowing to any depot.

3.4 Tabu search for the TECFLP-PSS

Tabu search (TS), introduced by Glover (1986), is a local search based metaheuristic. The TS explores the solution space by moving from the current solution to another in its neighborhoods. A candidate solution is accepted even if this solution deteriorates the function value, according to an aggressive admission criterion to avoid getting trapped in local optima. To prevent the possibility of cycling, a tabu list is introduced to forbid moves from recently visited solutions for several iterations. However, forbidden moves can be overridden by some aspiration criteria. Finally, the TS terminates when stopping criteria are met. The TS has been widely applied in various combinatorial optimization problems, such as job shop scheduling (Hertz and Widmer, 1996), assignment problem (D áz and Fernández, 2001) and vehicle routing problem (Gendreau and Hertz, 1994), etc. Thus the TS is adopted here to further improve the best upper bound found by the Lagrangean heuristic. The details of the implementation of the TS are described in the following subsection.

3.4.1 Move and neighborhood definitions

In the implementation of the TS, we first fix the locations of the plants, their sizes and the locations of the depots as the input feasible solution. We only consider changes of customer-depot assignments. Two kinds of moves are used: *shift* reassigns one customer from one depot to another, and *swap* interchanges the assignments of two customers that are currently assigned to two different depots. Let $N_{shift}(\xi)$ and $N_{swap}(\xi)$ denote the neighbourhood of solution ξ , which contains the set of feasible solutions that can be attained from ξ by performing either a shift or a swap move, respectively.

3.4.2 Evaluation of moves

Define a evaluation value (EV) as the cost variations incurred by a move. The EV includes the variation of the fixed opening cost of depot EV_d , the assignment cost EV_a and the flow cost EV_f , i.e., $EV = EV_d + EV_a + EV_f$. The EV_d and EV_a can be directly obtained by calculating the differences of the cost before and after the move is performed. The EV_f can also be determined by solving a transportation problem. However, as the number of trial solutions of $N_{shift}(\xi)$ and $N_{swap}(\xi)$ may be $O(|J| \cdot |K|)$ and $O(|J| \cdot |K|^2)$, it is very time consuming to solve a transportation problem to obtain the EV_f for each trial solution. To reduce the computation effort, we prefer to estimate the EV_f heuristically. Note that the EV_f is 0 if two customers with the same quantities of demand are swapped.

3. Two-echelon capacitated facility location problem with plant size selection

We observe that performing a shift or a swap move will lead to a decrease of aggregated demand at one depot and an increase of the same quantity at another depot. Let d be the absolute value of variation in demand, j' and j'' be the index of the depot whose aggregated demand is decreased and increased after performing a move respectively. To make the solution feasible, we need to remove d units of flows flowing out from plants to the depot j' and add d units of flow flowing out from plants to the depot j'' to satisfy the flow conservation constraints (3-4). In order to remove d units of demand from the depot j' as optimal as possible, we first sort the plants with $x_{ij'} > 0$ in a non-increasing order according to their $p_{ir} + t_{ij'}$ values, and initialize the residual demand as $d_r := d$. Then, in the same order, we remove $\mu = \min\{x_{ij'}, d_r\}$ units of flow from each plant by setting $x_{ij'} := x_{ij'} - \mu$ and $d_r := d_r - \mu$. This procedure is repeated until d units of flows flowing to the depot j' have been removed.

In a similar way, to add d units of flows to the depot j'' as optimal as possible, we first sort the plants with $u_{ir} = 1$ and $cp_{ir} - \sum_{j \in J} x_{irj} > 0$ in a non-decreasing order according to their $p_{ir} + t_{ij''}$ values, and initialize $d_a := d$ as the demands that need to be added. Then, in the same order, we add $\mu = \min\{cp_{ir} - \sum_{j \in J} x_{irj}, d_a\}$ units of flow each plant to depot j'' by setting $x_{irj''} := x_{irj''} + \mu$ and $d_a := d_a - \mu$. This procedure is repeated until d units of flow have been added to the depot j'' .

The EV_f is computed as the variations of the flow cost after and before the removing and adding procedure. The computation of EV_f is summarized in Algorithm 3.4.

Algorithm 3.4: Computation of EV_f

Step 1: Set $d_r := d$ and $EV_f = 0$.

Step 1.1: Sort the plants $i \in I$ with $x_{ij'} > 0$ in non-increasing order according to their $p_{ir} + t_{ij'}$ values.

Step 1.2: In this same order, while $d_r > 0$, delete $\mu = \min\{x_{ij'}, d_r\}$ quantity of flow from plant i to depot

j' by setting $x_{ij'} := x_{ij'} - \mu$. Set $EV_f := EV_f - (p_{ir} + t_{ij'}) \cdot \mu$, $d_r := d_r - \mu$.

Step 2: Set $d_a := d$.

Step 2.1: Sort the plants $i \in I$ with $u_{ir} = 1$ in non-decreasing order according to their $p_{ir} + t_{ij''}$.

Step 2.2: In this same order, while $d_a > 0$, add $\mu = \min\{cp_{ir} - \sum_{j \in J} x_{irj}, d_a\}$ quantity of flows from plant i to

depot j'' by setting $x_{irj''} := x_{irj''} + \mu$. Set $EV_f := EV_f + (p_{ir} + t_{ij''}) \cdot \mu$, $d_a := d_a - \mu$.

3.4.3 Search strategy

In the implementation of the TS, the best accept strategy is adopted. That is, at each iteration of the TS, the value EV of all of the possible shift and swap moves that will not lead to infeasible assignments with respect to depot capacity in the neighbourhood of the current solution is calculate calculated first. Then, the

best admissible move (with the smallest EV) is performed. The product flows from the plants to the depots are then adjusted according to the computation of the EV_f . A $|K| \cdot |J|$ tabu list (TL) is employed to avoid looping back to previous visited solutions in the search process. The element (k, j) of the TL records the last iteration number that it will be forbidden to assign customer k to depot j . If a customer k is reassigned to a depot j at iteration l , the value of element (k, j) is reset to $l + t$, which means any solution with the customer k assigned to the depot j will be forbidden for the next t iterations. We adopt a random dynamic tenure which uses a tenure range defined by parameters T_{\min} and T_{\max} . The tabu tenure t is selected randomly within this range, following a uniform distribution. The aspiration criterion used in the TS is based on the EV and the current solution quality. Let UB be the objective value of the current solution and BUB be the objective value of the best solution found so far. If UB plus EV of the move is less than BUB , it is selected and performed in spite that it leads to tabu customer-depot assignments. Otherwise it is accepted only when it does not lead to tabu customer-depot assignments. The TS procedure is terminated if the maximum number iteration is reached or the best upper bound found so far is not improved in a successive number of iterations. After the TS, the product flows from the plants to the depots are optimally determined by solving the corresponding transportation problem.

3.5 Computational results

The proposed Lagrangean relaxation approach and the TS were coded in C++. Numerical experiments were carried out on a personal computer with Intel® Core™ 2 2.33 GHz Quad CPU Q8200 and 2 G RAM under Microsoft Windows 7 operating system. In section 3.5.1, we describe the way to create random instances. In section 3.5.2, 50 instances are tested to evaluate the solution quality of the Lagrangean relaxation and the TS. In addition, 195 instances with different problem parameters, e.g., the ratio of plant capacity to customer demand, the ratio of depot capacity to customer demand and the number of plant size, are tested to show the speed and the quality of the proposed Lagrangean relaxation approach and the TS.

3.5.1 Test instances

No instances are publicly available for the TECFLP-PSS since it is a new problem. Thus the instances of the TECFLP-PSS are randomly generated in our test. Based on the instance generation of the CFLP (Cornuejols et al., 1991) and the TSCFLP (Klose, 2000), the instances are generated in the following way. The coordinates of the potential plants, depots and customers are randomly selected from a unit square. The unit transportation costs are 10 times the Euclidean distance between the locations. Let $U[a, b]$ denote a uniform distribution in interval $[a, b]$. The demand d_k of customer $k \in K$ is generated from $U[5, 35]$. Assuming that $cp_{ip} \leq cp_{iq}$ if $p \leq q$, we first generate the capacity $cp_{i|R_i|}$ for each plant from $U[10, 160]$ and then scale the capacities using the ratio $r_{cpd} = \sum_{i \in I} cp_{i|R_i|} / \sum_{k \in K} d_k$. For each $r < |R_i|$, cp_{ir} is set to $r \cdot cp_{i|R_i|} \cdot \sigma / |R_i|$, where σ is a parameter randomly selected from $U[0.9, 1.1]$. Similarly, the capacity cd_j for $j \in J$ is

generated from $U[10, 160]$ and scaled by using ratio $r_{\text{cdd}} = \sum_{j \in J} cd_j / \sum_{k \in K} d_k$. To embody the plants' economies of scale, the cost of production per unit for a smaller size is assumed to be larger than that for a bigger size of the same plant. For each plant $i \in I$, we first generate the unit production cost p_{i1} from $U[5, 7]$. Then, for any $r > 1$, the p_{ir} is obtained by multiplying the production cost $p_{i(r-1)}$ by a random parameter selected from $U[0.9, 0.95]$. The fixed opening costs for each size of a plant or a depot is obtained by multiplying its capacity by a parameter selected from $U[20, 25]$.

3.5.2 Results

In our implementation of the subgradient procedure, the parameters are set as follows: $L_{\text{Lag}} = 5000$, $\varepsilon_{\text{Lag}} = 10^{-4}$, $N_{\text{Lag}} = 40$ and $\lambda_0 = 1.5$. For the TS, the parameters T_{min} and T_{max} are set to 10 and 15 respectively. The loop of the TS is terminated if the maximum number 2000 iterations is reached, or if the *BUB* has not been improved in the previous 200 successive iterations. The CPLEX version 12.5 with default setting is used as the MIP solver to evaluate the proposed algorithms.

Let UB_{Lag} be the *BUB* found by the Lagrangean relaxation approach, UB_{TS} be the *BUB* found by the TS, UB_{C1} be the *BUB* found by CPLEX without time limitation, UB_{C2} be the *BUB* found by CPLEX within time limit of T_{LagTS} and LB_{Lag} be the *BLB* found by the Lagrangean relaxation approach. The computational results are shown in Tables 3.1-3.4. For each problem set, five instances are generated. To simplify the presentation, the column headings are as follows:

$ I \times J \times K $	the number of the plants, the depots and the customers respectively
G_{Lag}	the gaps between UB_{Lag} and LB_{Lag} , i.e., $(UB_{\text{Lag}} - LB_{\text{Lag}}) / LB_{\text{Lag}} \times 100$
G_{TS}	the gaps between UB_{TS} and LB_{Lag} , i.e., $(UB_{\text{TS}} - LB_{\text{Lag}}) / LB_{\text{Lag}} \times 100$
G_{TSC1}	the gaps between UB_{TS} and UB_{C1} , i.e., $(UB_{\text{TS}} - UB_{\text{C1}}) / UB_{\text{C1}} \times 100$
G_{TSC2}	the gaps between UB_{TS} and UB_{C2} , i.e., $(UB_{\text{TS}} - UB_{\text{C2}}) / UB_{\text{C2}} \times 100$
T_{Lag}	the CPU time used by the Lagrangean relaxation approach
T_{LagTS}	the CPU time used by the Lagrangean relaxation approach and the TS
T_{C1}	the CPU time of CPLEX without time limitation
R_{T}	the ratio of the time T_{C1} to the time T_{LagTS}
Avg.	the average value of gaps or computational times for each instance set
Max.	the maximum value of gaps or computational times for each instance set

In order to evaluate the solution quality of the proposed Lagrangean relaxation approach and the TS, we have compared the results of the Lagrangean relaxation approach and the TS with those of the following two versions of CPLEX (c1 and c2). For the CPLEX c1, no time limit is imposed. That is the CPLEX c1 terminates itself if an optimal solution is found or an “*Out of memory*” error occurs. For CPLEX c2, a time limit of T_{LagTS} is imposed.

The computational results are reported in Table 3.1. For the instances tested in Table 3.1, we set $r_{\text{cpd}} = 2.0$, $r_{\text{cdd}} = 2.0$ and $|R_i| = 3$. The experimental results show that CPLEX can find an optimal solution only for

3. Two-echelon capacitated facility location problem with plant size selection

the instances of set 1, and the programme meets an ‘out of memory’ error for the other sets. The average gaps between the Lagrangean upper bound and lower bound range from 0.96% to 1.82% and the maximum gap is 2.55%. It is clear that the Lagrangean relaxation approach provide both a well upper bounds and a good lower bounds for the TECFLP-PSS. The gaps between the TS upper bound and the Lagrangean lower bound range from 0.78% to 1.66% and the maximum gap is 2.04%, which indicate that the TS also performs well. The average gaps between the TS upper bounds and those of the CPLEX c1 range from -0.35% to 0.67%. This gap decreases as the problem size increases and the TS upper bounds is better than those of the CPLEX c1 for the large size problem, e.g., the gaps between the TS upper bounds and those of the CPLEX c1 for the set 9 and set 10 are -0.06% and -0.35% respectively. In terms of computational time, the CPLEX c1 takes much more CPU time, or about 180 times more than that required by the Lagrangean relaxation approach and the TS.

The average gaps between the TS upper bounds and those of the CPLEX c2 range from -1.09% to -0.31%, which means the TS upper bounds are much better than those of the CPLEX c2 for all the instances, and thus the Lagrangean relaxation approach with the TS is much more effective than CPLEX.

Table 3.1: Computational results and comparisons of the TS bounds with those of CPLEX

I × J × K	G_{Lag} (%)		G_{TS} (%)		G_{TSC1} (%)		G_{TSC2} (%)		T_{LagTS} (s)		T_{C1} (s)	
	G_{Lag}	Avg.	G_{TS}	Avg.	G_{TSC1}	Avg.	G_{TSC2}	Avg.	T_{LagTS}	Avg.	T_{C1}	Avg.
5×20×40	1.62		1.61		0.85		0.01		6.7		186.0	
	1.98		1.91		0.40		-0.01		8.3		457.0	
	2.55	1.82	2.04	1.66	0.41	0.53	-0.43	-0.31	7.1	6.7	164.6	257.3
	1.14		1.07		0.33		-0.60		5.2		250.8	
	1.79		1.68		0.66		-0.50		5.8		228.2	
10×40×80	1.63		1.39		0.36		-0.42		13.3		12287.3	
	1.75		1.48		0.59		-0.97		14.2		17331.8	
	1.92	1.74	1.53	1.46	1.06	0.67	0.63	-0.74	12.7	13.4	23412.4	16924.0
	2.00		1.72		1.08		-1.53		14.0		14643.9	
	1.42		1.17		0.28		-1.43		12.7		16944.7	
15×60×120	2.01		1.75		0.76		-0.57		26.3		5067.0	
	1.11		0.99		0.19		-0.91		23.9		7686.6	
	1.53	1.57	1.32	1.34	0.63	0.49	-1.53	-1.09	27.1	28.8	10129.1	6509.0
	1.77		1.54		0.51		-0.91		34.6		4554.9	
	1.41		1.08		0.35		-1.55		32.2		5107.3	
20×80×160	1.25		1.12		0.45		-1.46		51.6		5938.5	
	1.37		1.19		0.41		-0.36		56.4		6241.6	
	1.39	1.40	1.10	1.23	0.50	0.51	-0.97	-0.88	44.4	51.8	5906.9	6019.6
	1.32		1.14		0.35		-0.47		58.1		5878.5	
	1.67		1.61		0.81		-1.15		48.5		6132.3	
25×100×200	0.90		0.71		0.05		-2.32		117.4		5396.5	
	1.68		1.42		0.91		-0.04		117.3		7233.1	
	1.62	1.31	1.11	1.05	0.31	0.44	-0.26	-0.94	112.7	120.0	5852.6	6744.0
	1.05		0.93		0.36		-1.72		145.2		7627.9	
	1.29		1.08		0.57		-0.35		107.5		7609.8	
30×120×240	1.06		1.01		0.27		-0.80		265.0		9762.3	
	1.30		1.21		0.54		-0.87		234.1		9580.4	
	0.92	1.30	0.77	1.13	0.08	0.34	-0.31	-0.68	207.7	231.7	6692.4	8224.5
	1.64		1.48		0.60		-0.03		225.5		8192.2	

3. Two-echelon capacitated facility location problem with plant size selection

	1.56	1.18	0.21	-1.41	226.0	6895.0						
	1.53	1.29	0.59	-0.28	330.8	11229.9						
	1.35	1.16	0.31	-1.28	343.4	10510.9						
35×140×280	0.90	1.17	0.72	0.98	0.07	0.28	-1.52	-0.80	300.1	337.9	9250.9	10460.5
	0.93	0.84	0.15	-0.51	349.2	10675.7						
	1.14	0.88	0.25	-0.41	365.9	10635.1						
	1.04	0.78	0.04	-0.72	433.7	12063.3						
	1.13	0.87	0.05	-1.01	524.4	10928.4						
40×160×320	1.32	1.15	0.80	0.83	-0.15	0.03	-0.56	-0.69	496.6	482.2	9849.8	11598.9
	1.28	1.15	0.29	-0.65	466.9	11590.2						
	0.97	0.58	-0.09	-0.53	489.7	13562.7						
	1.12	0.87	0.00	-0.44	815.2	10769.2						
	0.93	0.75	-0.16	-1.03	643.2	14848.6						
45×180×360	0.89	0.96	0.76	0.78	-0.09	-0.06	-1.04	-0.84	671.4	685.1	14236.4	12588.8
	1.01	0.80	-0.03	-0.55	661.6	10822.5						
	0.84	0.70	-0.04	-1.14	633.9	12267.5						
	1.13	0.86	-0.37	-0.52	898.0	6082.6						
	0.97	0.82	-0.31	-0.66	938.1	7204.5						
50×200×400	0.89	1.06	0.81	0.83	-0.40	-0.35	-0.57	-0.52	924.2	952.9	6478.8	6493.0
	1.13	0.88	-0.22	-0.34	1061.1	6303.2						
	1.18	0.80	-0.43	-0.52	943.1	6395.9						
Average	1.35	1.13	0.29	-0.75								

The performances of the proposed algorithm for the instances with different plant capacities and problem sizes are reported in Table 3.2. The parameters r_{cdd} and $|R_i|$ are set to 2.0 and 3, respectively, in Table 3.2. We observed that the average gaps between the Lagrangean upper bounds and lower bounds range from 0.95% to 1.58% and the maximum gap is 1.89%, the average gaps between the TS upper bounds and the Lagrangean lower bounds range from 0.72% to 1.31% and the maximum gap is 1.67%, which indicate that the Lagrangean relaxation approach and the TS perform well and they are effective for problems with different ratio r_{cpd} . It can also be seen from Table 2, both the average gaps between the Lagrangean upper bounds and lower bounds, and the average gaps between the TS upper bounds and the Lagrangean lower bounds increase for the same sized problem as the ratio r_{cpd} increases, e.g., for the 50×200×400 instances, the average gaps between the Lagrangean upper bounds and lower bounds are 0.95%, 1.08%, 1.22% and 1.52% for $r_{\text{cpd}} = 1.5, 2.0, 2.5$ and 3.0 respectively, and the average gaps between the TS upper bounds and the Lagrangean lower bounds are 0.72%, 0.83%, 0.97% and 1.22% for $r_{\text{cpd}} = 1.5, 2.0, 2.5$ and 3.0 respectively. It can be concluded that the Lagrangean relaxation approach and the TS are more effective for smaller ratio r_{cpd} than for larger ratio r_{cpd} and which can be also seen from the computational time of the Lagrangean relaxation approach and the TS. As seen from Table 2, for the 50×200×400 instances, the average CPU time are 889.6, 937.2, 1184.9 and 1562.3 for $r_{\text{cpd}} = 1.5, 2.0, 2.5$ and 3.0 respectively. For instances of the same size, the average duality gap of the Lagrangean approach is somewhat proportional to the ratio r_{cpd} . This proportionality arises because the larger the value r_{cpd} , the smaller the number of plants that will be opened in the solution. Once ‘wrong’ plants are selected, the duality gap may be huge.

Table 3.2: Computational results on the instances with different ratio r_{cpd}

$ I \times J \times K $	r_{cpd}	$G_{\text{Lag}}(\%)$	$G_{\text{TS}}(\%)$	$T_{\text{Lag}}(\text{s})$	$T_{\text{TS}}(\text{s})$	$T_{\text{LagTS}}(\text{s})$
-----------------------------	------------------	----------------------	---------------------	----------------------------	---------------------------	------------------------------

3. Two-echelon capacitated facility location problem with plant size selection

		G_{Lag}	Avg.	G_{TS}	Avg	T_{Lag}	Avg.	T_{TS}	Avg.	T_{LagTS}	Avg.
25×100×200	1.5	1.38	1.48	0.84	1.14	105.0	92.3	19.7	20.4	124.6	112.7
		1.43		1.09		83.9		17.5		101.4	
		1.86		1.67		91.5		21.0		112.5	
		1.31		1.12		83.2		10.3		93.5	
		1.40		1.00		98.1		33.6		131.7	
25×100×200	2.0	1.05	1.26	0.79	1.00	95.9	95.9	8.7	11.4	104.7	107.3
		1.49		1.06		88.8		18.6		107.4	
		1.29		1.01		98.0		6.2		104.2	
		0.84		0.69		94.8		12.5		107.2	
		1.64		1.43		102.0		11.2		113.2	
25×100×200	2.5	1.41	1.54	1.13	1.19	160.1	143.6	18.6	11.2	154.8	154.8
		1.61		1.45		154.1		8.2		162.2	
		1.89		1.23		117.6		6.8		124.4	
		1.44		1.18		168.6		6.5		175.1	
		1.33		0.94		117.8		16.0		133.8	
25×100×200	3.0	1.42	1.58	1.24	1.24	210.4	200.8	3.6	23.6	214.0	224.5
		1.83		1.46		200.0		44.8		244.7	
		1.45		1.03		212.8		13.9		226.7	
		1.43		1.08		173.4		12.4		185.8	
		1.75		1.41		207.6		43.5		251.1	
35×140×280	1.5	1.20	1.04	1.02	0.79	300.7	256.7	37.7	36.9	338.4	293.6
		0.73		0.52		248.9		21.8		270.7	
		1.68		1.30		242.1		51.2		293.2	
		0.89		0.59		238.2		39.8		278.0	
		0.67		0.54		253.6		33.9		287.4	
35×140×280	2.0	1.10	1.19	0.94	0.92	324.4	272.9	32.7	41.7	357.1	314.6
		1.21		1.01		313.4		57.5		371.0	
		1.45		0.93		252.7		48.0		300.7	
		1.07		0.82		243.7		44.8		288.5	
		1.11		0.89		230.0		25.6		255.7	
35×140×280	2.5	1.27	1.47	1.02	1.24	406.8	372.9	38.1	35.2	444.9	408.1
		1.43		1.13		335.3		25.1		360.4	
		1.63		1.51		311.9		51.9		363.8	
		1.44		1.25		380.8		29.1		409.9	
		1.59		1.29		429.9		31.7		461.6	
35×140×280	3.0	1.69	1.56	1.52	1.31	519.8	490.5	29.8	31.7	549.5	522.2
		1.73		1.56		516.6		32.7		549.3	
		1.53		1.25		513.3		25.5		538.8	
		1.37		1.22		453.3		48.2		501.4	
		1.46		1.00		449.8		22.3		472.0	
50×200×400	1.5	1.11	0.95	0.90	0.72	715.3	707.2	305.6	182.4	1020.9	889.6
		0.94		0.59		685.0		267.1		952.1	
		0.77		0.54		737.0		100.3		837.3	
		0.92		0.79		705.7		142.9		848.6	
		1.00		0.79		693.0		96.1		789.1	
50×200×400	2.0	1.07	1.08	0.67	0.83	724.6	790.9	121.0	146.3	845.6	937.3
		1.25		1.03		860.2		187.0		1047.2	
		1.01		0.77		706.0		165.8		871.7	
		0.98		0.82		834.5		128.5		963.1	

3. Two-echelon capacitated facility location problem with plant size selection

		1.07		0.86		829.4		129.4		958.8	
		1.27		0.98		997.6		119.7		1117.3	
		1.28		1.14		1002.3		173.8		1176.1	
50×200×400	2.5	1.30	1.22	1.01	0.97	1008.8	1064.3	95.0	117.6	1103.8	1181.9
		1.20		0.79		1278.2		92.1		1370.2	
		1.05		0.92		1034.6		107.6		1142.1	
		1.70		1.40		1367.1		101.3		1468.4	
		1.25		0.93		1319.8		149.3		1469.0	
50×200×400	3.0	1.53	1.52	1.23	1.22	1645.6	1438.5	97.8	123.8	1743.4	1562.3
		1.55		1.35		1519.0		173.1		1692.0	
		1.55		1.20		1341.3		97.6		1438.9	
Average		1.32		1.05							

The performances of the proposed Lagrangean relaxation approach and the TS on instances with different ratio r_{cdd} are reported in Table 3.3. For all the instances given in Table 3.3, $r_{cpd} = 1.5$ and $|R_i| = 3$. The average gaps between the Lagrangean upper bounds and lower bounds range from 0.96% to 1.38% and the maximum gap is 1.74%, the gaps between the TS upper bounds and the Lagrangean lower bounds range between 0.76% and 1.07% on average and the maximum gap is 1.40%, which indicate that the Lagrangean relaxation approach and the TS perform well and they are effective for problems with different ratio r_{cdd} . In addition, both the average gaps between the Lagrangean upper bounds and lower bounds, and the average gaps between the TS upper bounds and the Lagrangean lower bounds for the instances of the same size decrease as the ratio r_{cdd} increases, e.g., for the 50×200×400 instances, the average gaps between the Lagrangean upper bounds and lower bounds are 1.37%, 1.18%, 1.07% and 0.96% for $r_{cdd} = 1.5, 2.0, 2.5$ and 3.0 respectively, and the average gaps between the TS upper bounds and the Lagrangean lower bounds are 1.01%, 0.85%, 0.84% and 0.76% for $r_{cdd} = 1.5, 2.0, 2.5$ and 3.0 respectively. It is clear that the Lagrangean relaxation approach and the TS are more effective for larger ratio r_{cdd} than for smaller ratio r_{cdd} and which can also be seen from the computational time of the Lagrangean relaxation approach and the TS. As seen from Table 3.3, for the 50×200×400 instances, the average CPU time is 1197.5, 1002.3, 957.5 and 885.1 for $r_{cdd} = 1.5, 2.0, 2.5$ and 3.0 respectively.

Table 3.3: Computational results on the instances with different ratio r_{cdd}

$ I \times J \times K $	r_{cdd}	$G_{Lag} (%)$		$G_{TS} (%)$		$T_{Lag} (s)$		$T_{TS} (s)$		$T_{LagTS} (s)$	
		G_{Lag}	Avg.	G_{TS}	Avg.	T_{Lag}	Avg.	T_{TS}	Avg.	T_{LagTS}	Avg.
25×100×200	1.5	1.35		0.77		140.3		14.5		154.7	
		1.47		1.14		114.0		14.8		128.8	
		1.09	1.38	0.71	1.02	119.0	125.4	15.1	11.8	134.2	137.1
		1.74		1.40		123.4		9.3		132.8	
		1.23		1.06		130.1		5.2		135.3	
25×100×200	2.0	1.61		1.33		92.7		6.4		99.2	
		1.17		1.02		93.1		3.9		97.0	
		1.15	1.26	0.90	1.01	129.3	106.6	7.8	6.9	137.1	113.5
		1.24		0.99		106.6		7.7		114.2	
		1.14		0.82		111.5		8.6		120.1	
25×100×200	2.5	1.19		0.90		89.4		9.5		98.9	
		1.59		1.34		95.2		14.8		109.9	
		1.20	1.28	0.95	1.07	97.0	95.7	43.6	19.0	140.6	114.7

3. Two-echelon capacitated facility location problem with plant size selection

			1.00		0.89		107.4		7.6		115.1	
			1.43		1.28		89.3		19.7		109.0	
			1.22		0.92		99.1		15.2		114.2	
			1.44		1.01		97.9		23.8		121.7	
25×100×200	3.0	0.64	1.22	0.51	0.95	88.7	91.9	18.1	19.3	106.8	111.2	
			1.48		1.30		72.7		27.1		99.7	
			1.34		1.03		101.1		12.4		113.5	
			0.96		0.73		343.2		28.5		371.7	
			1.10		0.88		369.5		26.6		396.1	
35×140×280	1.5	1.03	1.08	0.68	0.79	304.2	328.7	19.8	27.1	324.0	355.9	
			1.49		1.10		280.5		37.5		318.0	
			0.80		0.56		346.2		23.2		369.5	
			1.35		1.09		261.4		88.1		349.6	
			1.45		1.08		236.8		45.8		282.6	
35×140×280	2.0	0.65	1.15	0.57	0.91	268.5	260.5	29.0	58.4	297.5	318.9	
			1.26		0.95		280.8		47.0		327.8	
			1.04		0.87		255.1		81.9		337.0	
			1.28		1.15		257.9		51.8		309.8	
			0.95		0.82		263.4		66.9		330.3	
35×140×280	2.5	1.24	1.19	0.94	1.01	253.4	265.0	23.4	43.6	276.8	308.6	
			1.22		1.08		291.0		48.6		339.6	
			1.27		1.05		259.5		27.1		286.7	
			1.21		1.09		255.0		56.5		311.4	
			0.87		0.76		223.6		81.7		305.3	
35×140×280	3.0	1.30	1.18	0.85	0.90	258.1	253.7	43.8	54.8	301.9	308.5	
			1.34		0.93		284.6		48.0		332.6	
			1.18		0.87		247.1		44.1		291.2	
			1.25		0.84		1230.7		133.3		1364.0	
			1.55		1.18		1073.6		159.6		1233.2	
50×200×400	1.5	1.34	1.37	1.04	1.01	996.8	1051.0	128.9	146.5	1125.7	1197.5	
			1.49		1.03		993.0		153.3		1146.3	
			1.22		0.97		961.2		157.4		1118.5	
			1.19		0.77		723.1		133.5		856.6	
			1.01		0.90		746.9		98.5		845.4	
50×200×400	2.0	1.30	1.18	0.98	0.85	814.5	827.5	359.8	174.8	1174.2	1002.3	
			1.19		0.74		1045.9		101.3		1147.2	
			1.21		0.88		807.0		181.2		988.2	
			1.14		0.95		830.4		92.7		923.1	
			1.05		0.85		830.5		147.7		978.2	
50×200×400	2.5	0.98	1.07	0.70	0.84	818.9	813.7	57.7	143.8	876.6	957.5	
			1.14		0.96		829.3		224.4		1053.7	
			1.02		0.73		759.6		196.4		956.0	
			1.08		0.81		779.0		83.5		862.5	
			1.07		0.69		770.8		158.2		929.0	
50×200×400	3.0	0.71	0.96	0.65	0.76	709.8	751.5	122.4	133.6	832.2	885.1	
			0.89		0.81		743.1		157.0		900.1	
			1.06		0.86		754.8		147.0		901.8	
Average			1.19		0.93							

Table 3.4 provide an analysis of the performances of the proposed Lagrangean relaxation approach and

3. Two-echelon capacitated facility location problem with plant size selection

the TS on instances with different numbers of plant size. For all of the instances given in Table 3.4, $r_{cpd} = 2.0$ and $r_{cdd} = 2.0$. The Lagrangean relaxation approach and the TS perform well in that the average gaps between the Lagrangean upper bounds and lower bounds range from 1.04 % to 1.42% and the maximum gap is 1.71%, the average gaps between the TS upper bounds and the Lagrangean lower bounds range between 0.77% and 1.16% and the maximum gap is 1.37%. In addition, the number of the plant size does not have a significant influences on the solution quality, e.g., for the $50 \times 200 \times 400$ instances, the average gaps between the TS upper bounds and the Lagrangean lower bounds are 0.82%, 0.84%, 0.86%, 0.85% and 0.77% for $|R_i| = 2, 3, 4, 5$ and 6 respectively. However, the computational time of the Lagrangean relaxation approach and the TS increases regularly as the number of plant size increases, e.g., for the $50 \times 200 \times 400$ instances, the average CPU time is 814.5, 1006.7, 1066.1, 1195.9 and 1268.3 seconds for $|R_i| = 2, 3, 4, 5$ and 6 respectively.

Table 3.4: Computational results on the instances with different numbers of plant size

$ I \times J \times K $	$ R_i $	$G_{Lag} (%)$		$G_{TS} (%)$		$T_{Lag} (s)$		$T_{TS} (s)$		$T_{LagTS} (s)$		
		G_{Lag}	Avg.	G_{TS}	Avg.	T_{Lag}	Avg.	T_{TS}	Avg.	T_{LagTS}	Avg.	
$25 \times 100 \times 200$	2			1.39		1.11		89.7		9.3		99.0
				1.50		1.24		83.7		12.6		96.3
			1.08	1.33	0.75	1.06	99.8	89.3	8.5	8.7	108.3	97.9
			1.24		0.99		73.4		7.2		80.6	
			1.45		1.18		99.7		5.9		105.6	
$25 \times 100 \times 200$	3			1.43		1.08		98.3		8.2		106.5
				1.02		0.73		91.7		12.9		104.6
			1.09	1.27	0.90	1.03	126.5	101.3	8.9	10.2	135.5	111.5
			1.25		1.12		96.6		7.8		104.4	
			1.58		1.34		93.3		13.2		106.5	
$25 \times 100 \times 200$	4			1.48		1.23		99.4		22.6		122.0
				1.71		1.37		119.8		10.4		130.2
			0.92	1.40	0.81	1.13	116.7	115.9	5.2	11.2	121.9	129.7
			1.50		1.13		108.3		8.7		117.0	
			1.40		1.10		135.2		22.1		157.3	
$25 \times 100 \times 200$	5			1.32		1.16		125.1		10.1		135.2
				1.04		0.90		97.0		5.2		102.1
			1.68	1.42	1.28	1.16	122.5	119.0	12.6	10.0	135.0	129.0
			1.61		1.22		129.1		8.2		137.3	
			1.47		1.25		121.6		13.9		135.5	
$25 \times 100 \times 200$	6			0.90		0.64		123.3		6.5		129.8
				1.28		0.87		167.0		5.4		172.4
			1.55	1.28	1.37	1.00	143.6	146.5	11.2	9.0	154.7	155.5
			1.12		0.85		132.4		11.3		143.6	
			1.54		1.29		166.2		10.6		176.8	
$35 \times 140 \times 280$	2			1.39		1.09		242.7		92.9		335.6
				1.36		1.17		292.2		39.9		332.1
			1.38	1.37	1.07	1.06	233.8	238.7	38.6	49.1	272.4	287.9
			1.61		1.22		200.6		37.5		238.1	
			1.13		0.76		224.3		36.8		261.1	
$35 \times 140 \times 280$	2			0.96		0.85		314.2		52.5		366.7
				1.33		0.98		303.0		45.4		348.4

3. Two-echelon capacitated facility location problem with plant size selection

35×140×280	3	1.65	1.27	1.21	0.97	287.7	288.1	82.0	44.7	369.8	332.8
		1.46		1.15		289.7		25.5		315.3	
		0.94		0.65		245.7		17.9		263.7	
35×140×280	4	1.05	1.12	0.87	0.90	304.1	327.8	31.8	43.7	335.9	371.5
		1.32		1.08		282.6		47.5		330.1	
		1.30		0.93		321.2		28.5		349.7	
		1.03		0.91		329.9		81.2		411.1	
		0.92		0.74		401.4		29.5		430.9	
35×140×280	5	0.88	1.22	0.66	0.97	407.9	332.8	21.5	44.2	429.4	377.0
		1.40		1.13		355.2		68.7		423.8	
		1.39		1.21		344.6		65.3		409.9	
		1.08		0.97		265.0		33.8		298.8	
		1.33		0.88		291.4		31.9		323.3	
35×140×280	6	1.08	1.20	0.90	0.97	394.0	377.7	90.5	51.2	484.5	428.9
		1.44		1.11		353.5		49.0		402.5	
		1.11		0.90		406.7		46.5		453.2	
		1.08		0.76		365.3		42.8		408.1	
		1.30		1.16		369.1		27.2		396.3	
50×200×400	2	1.12	1.08	0.88	0.82	648.4	684.1	74.6	130.4	723.0	814.4
		0.72		0.64		722.1		73.1		795.2	
		1.22		0.85		701.7		110.0		811.6	
		1.23		1.09		690.8		163.5		854.3	
		1.13		0.65		657.4		230.7		888.0	
50×200×400	3	1.30	1.13	0.92	0.84	906.2	864.6	173.8	142.1	1080.0	1006.7
		1.16		0.79		841.7		109.6		951.2	
		1.15		0.89		898.0		131.7		1029.7	
		1.02		0.85		795.3		161.1		956.4	
		1.03		0.76		881.7		134.6		1016.3	
50×200×400	4	0.91	1.09	0.71	0.86	923.7	933.9	182.8	132.2	1106.5	1066.2
		1.29		1.02		913.7		123.5		1037.2	
		1.08		0.80		1049.8		103.8		1153.6	
		0.85		0.68		851.1		156.6		1007.7	
		1.32		1.10		931.4		94.6		1025.9	
50×200×400	5	1.13	1.08	0.96	0.85	1168.2	1060.9	153.9	135.0	1322.2	1195.9
		0.98		0.82		1189.0		92.6		1281.7	
		1.07		0.78		999.5		200.1		1199.6	
		1.10		0.88		978.1		124.7		1102.9	
		1.11		0.80		969.7		103.6		1073.3	
50×200×400	6	1.03	1.04	0.66	0.77	1227.3	1158.4	127.9	109.9	1355.2	1268.3
		0.84		0.68		1301.9		69.8		1371.7	
		1.09		0.88		1112.4		82.5		1194.9	
		1.09		0.81		1093.2		112.9		1206.2	
		1.15		0.82		1057.3		156.1		1213.4	
Average		1.22		0.96							

3.6 Conclusions

The decision of facility location and size is one of the most important strategy decisions for firms in today's competitive environment. Appropriate facility location and size can save operational cost on a long

3. Two-echelon capacitated facility location problem with plant size selection

time horizon. In the traditional two-stage facility location problem, the capacity of a facility is assumed to be fixed, either uncapacitated or capacitated. However, there is often a need to consider several size of a facility in the real world. To deal with this situation, we study the TECFLP-PSS in which each plant has several sizes exhibiting different capacities. A mixed integer programming model is formulated. This extended model can then simultaneously determine the locations and sizes of the plants, the locations of the depots, the product flows from the plants to the depots and the assignments of the customers to the depots to satisfy the customers' demands. To solve the problem, a Lagrangean relaxation approach and a TS are proposed. First the Lagrangean relaxation approach is used to find good lower and upper bounds, and then the TS is applied to improve the *BUB* found in the Lagrangean relaxation approach. A total of 245 instances are randomly generated and tested. The computational results demonstrate that all of the instances can be solved in a reasonable time with the average gaps below 1.66%, even for instances that have up to 50 potential plants with 6 possible sizes each, 200 potential depots and 400 customers. Moreover, the performance of the proposed algorithms on the instances with different characteristics, such as the ratios of plant capacity to customer demand, the ratios of depot capacity to customer demand and the number of depot size, are analyzed and the results show that the proposed algorithms are effective for the instances with different parameters.

The Lagrangean relaxation approach and TS perform well for the TECFLP-PSS. However, some new ideas on solving the problems could be investigated, such as adding valid inequalities to accelerate the solution process, designing improvement strategies for the Lagrangean relaxation approach or TS. Moreover, Lagrangean core heuristic could be designed to find a better upper bound of the TECFLP-PSS.

Chapter 4

Two-echelon capacitated facility location problem with depot size selection

4.1 Introduction

The classical two-stage facility location problem focus on determining the locations of plants and depots, and the flows of product through the system from plants to customers with the goal of minimizing the sum of facilities opening costs and shipping costs. The capacity of the depots are either uncapacitated or capacitated, i.e., each depot has only one choice of capacity. The opening cost of a depot is a constant and the unit handling cost is the same for all of the depots, thus it can be merged with other linear connection costs. However, in practice, there is often a need for considering several possible sizes for each depot. To deal with this situation, in this chapter, we study a two-echelon capacitated facility location problem with depot size selection (TECFLP-DSS). In this problem we simultaneously locate plants and depots, and select sizes for the located depots, where each plants in the first stage is capacitated. Each depot in the second stage has several potential sizes exhibiting different capacities and is supplied by multiple plants. Each customer in the third stage is serviced by only one depot. This problem will not allow us to deal with different depot sizes, but also with different handling costs at different levels of handling at a depot. The objective of this problem is to determine simultaneously the locations the plants, the locations and sizes of the depots, the product flows from the plants to the depots and the assignments of the customers to the depots to satisfy the customers' demands.

As stated in Chapter 3, the fixed opening cost of a facility depends on the size of the facility opened. It is not realistic to expect that different size of a facility at the same site have the same fixed opening cost. Therefore, in the TECFLP-DSS, the fixed opening costs are assumed to be different for different sizes of a depot, i.e., the fixed opening cost for a larger size of a depot is larger than those of the smaller sizes of the same depot. Also, to model economies of scale, the unit handling cost for a larger size of a depot is smaller than those of the smaller sizes of the same depot. The distinguishing features of the TECFLP-DSS are as follows: 1) there are several sizes for each potential depots that can be opened, 2) handling cost is taken into account specifically since the unit handling cost for a larger size of a depot is smaller than those of the smaller sizes of the same depot, thus it cannot be merged with other linear connection costs like it is done in the classical facility location model.

The TECFLP-DSS is also an extension of the TSCFLP and NP-hard in strong sense. Due to the NP-hardness of the TECFLP-DSS, we concentrate on finding suboptimal solutions for it in a reasonable time. For this problem, we first present a mixed integer programming model and then design a Lagrangean relaxation approach to achieve good lower and upper bounds. At last, a hybrid variable neighborhood tabu search algorithm (HVNTS) is designed to further improve the best upper bound found by the Lagrangean relaxation approach. To solve the dual problem arising in the Lagrangean relaxation approach, we make use a subgradient optimization method. The Lagrangean relaxation problem can be decomposed into two subproblems, one can be transformed into a 0-1 knapsack problem and another one can be decomposed further into the classical 0-1 knapsack problem. The 0-1 knapsack problems are exactly solved in a very

reasonable time by using the MINKNAP developed by Pisinger (1995). In order to construct feasible solution and find an upper bound, we design a heuristic by repairing the Lagrangean relaxation solutions. The HVNTS focus on improving the customer-depot assignments. If better customer-depot assignments are found, the optimal product flows are determined by solving a transportation problem using commercial solver CPLEX.

We test 245 randomly generated instances to evaluate the proposed Lagrangean relaxation approach and HVNTS. First 50 instances with different problem size are tested to show the general performance of the Lagrangean relaxation approach and HVNTS. The Lagrangean upper bounds are compared with the Lagrangean lower bounds and the upper bounds provided by commercial MIP solver CPLEX, and the upper bounds obtained by the HSATS are also compared with those of CPLEX. The results show that the Lagrangean relaxation approach and HSATS are effective for the TECFLP-DSS since the gaps between the upper bounds and those of the CPLEX are less than 1.16% on average and the CPU time required by the Lagrangean relaxation and HVNTS is much less than that of the CPLEX. Moreover, to evaluate the robustness of the Lagrangean relaxation approach and HVNTS, 195 instances with different size and different parameters, such as the ratio of plant capacity to customer demand, the ratio of depot capacity to customer demand and the number of depot size are randomly generated. The computational results show that the proposed algorithms performance well for all of the instances and can solve all of the instances in an acceptable time, even for the instances that have up to 50 potential plants, 100 potential depots with 6 depot sizes each and 400 customers .

The rest of this chapter is organized as follows. In Section 4.2, a mixed integer programming model is developed for the TECFLP-DSS. In Section 4.3, a Lagrangean relaxation approach is proposed to achieve good lower and upper bounds. In Section 4.4, a HVNTS is proposed to improve the best upper bounds found by the Lagrangean relaxation approach. In Section 4.5, we evaluate the proposed algorithms on randomly generated instances. Conclusions are drawn in Section 4.6.

4.2 Problem formulation

Given a set of potential plants, a set of potential depots, each depot has several possible sizes exhibiting different capacities, and a set of customers with demands. The TECFLP-DSS is to optimally determine the locations of the capacitated plants, the locations and sizes of the depots, the product flows from the plants to the depots and the assignments of the customers to the depots to satisfy the customers' demands. The objective is to minimize the sum of the fixed opening costs of the plants and the depots, the handling costs at the depots, the transportation costs from the plants to the customers and the assignment costs of the customers to the depots. The structure of the TECFLP-DSS is presented in Fig. 4.1, where the first or upper-most stage is the plants, the second or central stage is the depots, each depot has several sizes exhibiting different capacities, and the third stage is the customers.

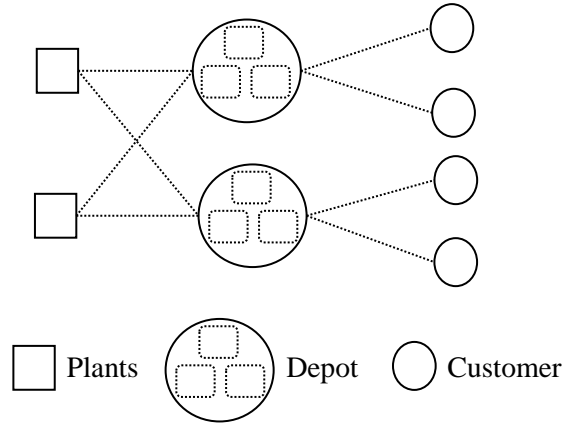

Fig. 4.1 The structure of the TECFLP-DSS

In the TECFLP-DSS, each size of a depot associates with a capacity cd , a fixed opening cost fd and a unit handling cost h . The fixed opening cost for a larger size of a depot is larger than those of the smaller sizes of the same depot. The unit handling cost h for a larger size of a plant is assumed to be smaller than those of the smaller sizes of the same depot to model the economies of scale. An example of the cost function including the fixed opening cost and the handling cost of a depot is illustrated in Fig. 4.2.

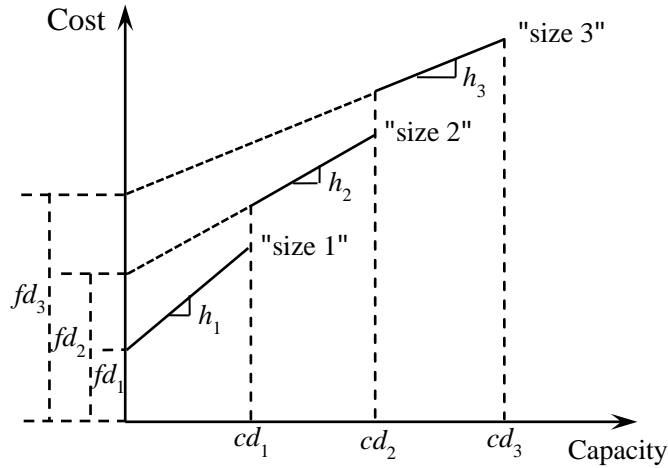

Fig 4.2. An example of the cost function of a depot

The notations and decision variables used to formulate the TECFLP-DSS are as follows:

Notations:

- I the set of potential plants;
- J the set of potential depots;
- K the set of customers;
- S_j the set of possible sizes of the depot $j \in J$;
- cp_i the capacity of the plant $i \in I$;

cd_{js}	the capacity of the depot $j \in J$ with the size $s \in S_j$;
d_k	the demand of the customer $k \in K$;
fp_i	the fixed cost of opening the plant $i \in I$;
fd_{js}	the fixed cost of opening the depot $j \in J$ with the size $s \in S_j$;
h_{js}	the unit handling cost at the depot $j \in J$ with the size $s \in S_j$;
t_{ij}	the unit transportation cost from the plant $i \in I$ to the depot $j \in J$;
c_{jk}	the unit assignment cost of the customer $k \in K$ to the depot $j \in J$;

Decision variables:

u_i	1, if the plant $i \in I$ is opened; 0, otherwise;
v_{js}	1, if the depot $j \in J$ with the size $s \in S_j$ is opened; 0, otherwise;
x_{ijs}	the quantity of product flow from the opened plant $i \in I$ to the opened depot $j \in J$ with the size $s \in S_j$;
z_{jsk}	1, if the customer $k \in K$ is assigned to the depot $j \in J$ with the size $s \in S_j$;

The TECFLP-DSS can be formulated as follows:

$$P: \quad \min \sum_{i \in I} fp_i \cdot u_i + \sum_{i \in I} \sum_{j \in J} \sum_{s \in S_j} t_{ij} \cdot x_{ijs} + \sum_{j \in J} \sum_{s \in S_j} fd_{js} \cdot v_{js} + \sum_{j \in J} \sum_{s \in S_j} \sum_{k \in K} (h_{js} + c_{jk}) \cdot d_k \cdot z_{jsk} \quad (4-1)$$

$$s.t. \quad \sum_{j \in J} \sum_{s \in S_j} x_{ijs} \leq cp_i \cdot u_i \quad \forall i \in I \quad (4-2)$$

$$\sum_{i \in I} x_{ijs} - \sum_{k \in K} d_k \cdot z_{jsk} = 0 \quad \forall j \in J, s \in S_j \quad (4-3)$$

$$\sum_{k \in K} d_k \cdot z_{jsk} \leq cd_{js} \cdot v_{js} \quad \forall j \in J, s \in S_j \quad (4-4)$$

$$\sum_{s \in S_j} v_{js} \leq 1 \quad \forall j \in J \quad (4-5)$$

$$\sum_{j \in J} \sum_{s \in S_j} z_{jsk} = 1 \quad \forall k \in K \quad (4-6)$$

$$\sum_{i \in I} cp_i \cdot u_i \geq \sum_{k \in K} d_k \quad (4-7)$$

$$u_i \in \{0, 1\} \quad \forall i \in I \quad (4-8)$$

$$v_{js} \in \{0, 1\} \quad \forall j \in J, s \in S_j \quad (4-9)$$

$$x_{ijs} \geq 0 \quad \forall i \in I, j \in J, s \in S_j \quad (4-10)$$

$$z_{jsk} \in \{0, 1\} \quad \forall j \in J, s \in S_j, k \in K \quad (4-11)$$

The objective (4-1) minimizes the sum of the fixed costs of opening the plants and depots, the transportation cost from the plants to the depots, the handling cost at the depots and the assignment cost of the customers to depots. The constraints (4-2) ensure that the total product flows moving out of an opened

plant cannot exceed its capacity and is zero if it is not opened. The constraints (4-3) are the flow equilibrium constraints at the depots. The constraints (4-4) make sure that the customers' demands assigned to an opened depot cannot exceed the capacity of its opened size and no customers are assigned to a closed depots. The constraints (4-5) ensure that only one size can be opened for each depot. The constraints (4-6) guarantee that each customer is assigned to exactly one opened depot. The constraint (4-7) is a redundant constraint. It means that the total capacity of the opened plants must be no less than the total demands of all of the customers. We add it to the TECFLP-DSS formulation to improve the Lagrangean lower bounds. The constraints (4-8), (4-9), (4-10) and (4-11) are standard nonnegativity and integrality constraints for decision variables.

The TECFLP-DSS is a generalization of the TSCFLP. As the TSCFLP is NP-hard in strong sense, so the TECFLP-DSS is also NP-hard in strong sense. To solve the TECFLP-DSS, especially for large-sized instances, we propose a Lagrangean relaxation approach and a HVNTS to find near-optimal solutions.

4.3 Lagrangean relaxation approach for the TECFLP-DSS

Due to the NP-hardness of the TECFLP-DSS, to solve the problem especially for those large-sized instances, we focus on finding effective lower and upper bounds for it in a reasonable time. The principle of Lagrangean relaxation approach is to relax hard constraints with Lagrangean multipliers into the objective function. The Lagrangean relaxation approach is one of the most effective approaches for achieving the lower and upper bounds for mixed integer linear programming problems. The Lagrangean relaxation approach has been widely applied to solve facility location problems, e.g., Geoffrion and McBride (1978) for the CFLP, Klincewicz and Luss (1986) for the SSCFLP, Klose (2000) for the TSCFLP, Tragantalerngsak et al. (1997) for a two-echelon, single-source, capacitated facility location problem.

Due to the effectiveness of the Lagrangean relaxation approach, we use it here to find effective lower and upper bounds to the TECFLP-DSS. The Lagrangean relaxation approach for the TECFLP-DSS is thus presented as follows.

4.3.1 Lagrangean relaxation model of the TECFLP-DSS

Similar as the TECFLP-PSS, two different Lagrangean relaxation problems can be generated by relaxing the constraints (4-2) and (4-6) or (4-3) and (4-6). Based on our experiments, relaxing the constraints (4-2) and (4-6) can generate better lower and upper bounds for the TECFLP-DSS than relaxing the constraints (4-3) and (4-6). Thus the constraints (4-2) and (4-6) are relaxed with the non-negative multipliers $\alpha_i (i \in I)$ and the multipliers $\beta_k (k \in K)$ respectively in our implementation. The Lagrangean relaxation problem $LR(\alpha, \beta)$ is as follows:

4. Two-echelon capacitated facility location problem with depot size selection

$$LR(\alpha, \beta) = \min \sum_{i \in I} (fp_i - \alpha_i) \cdot u_i + \sum_{i \in I} \sum_{j \in J} \sum_{s \in S_j} (t_{ij} + \alpha_i / cp_i) \cdot x_{ijs} \\ + \sum_{j \in J} \sum_{s \in S_j} fd_{js} \cdot v_{js} + \sum_{j \in J} \sum_{s \in S_j} \sum_{k \in K} (h_{js} \cdot d_k + c_{jk} \cdot d_k - \beta_k) \cdot z_{jks} + \sum_{k \in K} \beta_k \quad (4-12)$$

s.t. (4-3)-(4-5) and (4-7)-(4-11).

The $LR(\alpha, \beta)$ can be divided into two independent subproblems $LR_1(\alpha)$ and $LR_2(\alpha, \beta)$.

The first subproblem $LR_1(\alpha)$ is

$$LR_1(\alpha) = \max \sum_{i \in I} (\alpha_i - fp_i) \cdot u_i \quad (4-13)$$

s.t. (4-7) and (4-8),

which can be transformed into a classical 0-1 knapsack problem. Let $y_i = 1 - u_i, \forall i \in I$, the transformed problem is presented in the following.

$$P_{knapsack} = \max \sum_{i \in I} (fp_i - \alpha_i) \cdot y_i + \sum_{i \in I} (\alpha_i - fp_i) \quad (4-14)$$

$$s.t. \sum_{i \in I} cp_i \cdot y_i \leq \sum_{i \in I} cp_i - \sum_{k \in K} d_k \quad (4-15)$$

$$y_i \in \{0, 1\} \forall i \in I \quad (4-16)$$

where $fp_i - \alpha_i$ is viewed as the profit of the item $i \in I$, cp_i as the weight of item $i \in I$, and $\sum_{i \in I} cp_i - \sum_{k \in K} d_k$ as the capacity of the knapsack. We simply set $y_i = 0$ where $fp_i - \alpha_i \leq 0$, because the profit of those items are non-positive. This problem can be solved exactly by using the MINKNAP developed by Pisinger (1995).

The second subproblem $LR_2(\alpha, \beta)$ is

$$LR_2(\alpha, \beta) = \min \sum_{i \in I} \sum_{j \in J} \sum_{s \in S_j} (t_{ij} + \alpha_i / cp_i) \cdot x_{ijs} + \sum_{j \in J} \sum_{s \in S_j} fd_{js} \cdot v_{js} \\ + \sum_{j \in J} \sum_{s \in S_j} \sum_{k \in K} (h_{js} \cdot d_k + c_{jk} \cdot d_k - \beta_k) \cdot z_{jks} \quad (4-17)$$

s.t. (4-3)-(4-5) and (4-9)-(4-11).

We observe that the variables x_{ijs} and z_{jks} are connected only by the constraints (4-3). Thus there always exists an optimal solution of the $LR_2(\alpha, \beta)$ in which a depot j with size s is only supplied by the ‘cheapest source’. For any $i \in I, j \in J, s \in S_j$, set

$$x_{ijs} = \begin{cases} \sum_{k \in K} d_k \cdot z_{jks}, & i = \arg \min_{m \in I} (t_{mj} + \alpha_m / cp_m), \\ 0, & \text{otherwise.} \end{cases}$$

Let $w_{js} = \min_{m \in I} (t_{mj} + \alpha_m / cp_m)$, then $LR_2(\alpha, \beta)$ can be reduced to

$$LR_2(\alpha, \beta) = \min \sum_{j \in J} \sum_{s \in S_j} fd_{js} \cdot v_{js} + \sum_{j \in J} \sum_{s \in S_j} \sum_{k \in K} (h_{js} \cdot d_k + w_{js} \cdot d_k + c_{jk} \cdot d_k - \beta_k) \cdot z_{jks} \quad (4-18)$$

s.t. (4-4), (4-5), (4-9) and (4-11),

The $LR_2(\alpha, \beta)$ can be further decomposed into $|J|/|S_j|$ independent 0-1 knapsack problems, which can also be solved to optimality by using the MINKNAP developed by Pisinger (1995). Then $LR_2(\alpha, \beta)$ is solved by setting a maximum of one v_{js} to 1, with the smallest negative knapsack objective value for each $j \in J$.

Let $LB(\alpha, \beta)$ be the sum of the objective value of the solution of $LR_1(\alpha)$, $LR_2(\alpha, \beta)$ and $\sum_{k \in K} \beta_k$.

Obviously, $LB(\alpha, \beta)$ is a lower bound of the TECFLP-DSS for given Lagrangean multipliers (α, β) .

4.3.2 Subgradient optimization for the TECFLP-DSS

To obtain the best Lagrangean lower bound of the TECFLP-DSS, a subgradient optimization method is adopted to approximately solve the following Lagrangean dual problem.

$$D : \max_{\alpha \geq 0, \beta} LR(\alpha, \beta) \quad (4-19)$$

The subgradient optimization is an iterative procedure, which solves the Lagrangean relaxation problem and then updates the Lagrange multipliers for the next iteration according to the current subgradient information.

Let BUB and BLB be the best upper bound and the best lower bound of the TECFLP-DSS found so far in the previous $l - 1$ subgradient iterations and $(\hat{u}^l, \hat{x}^l, \hat{v}^l, \hat{z}^l)$ be the optimal solution of $LR(\alpha^l, \beta^l)$ at iteration l . Let $\gamma_i^l = \sum_{j \in J} \sum_{s \in S_j} \hat{x}_{ijs}^l - cp_i \cdot \hat{u}_i^l$, $\forall i \in I$ and $\eta_k^l = 1 - \sum_{j \in J} \hat{z}_{jk}^l$, $\forall k \in K$, the Lagrangean multipliers for the next iteration $l+1$ are updated as:

$$\alpha_i^{l+1} = \max\{\alpha_i^l + \theta^l \cdot \gamma_i^l, 0\} \quad (4-20)$$

$$\beta_k^{l+1} = \beta_k^l + \theta^l \cdot \eta_k^l \quad (4-21)$$

where $\theta^l = \lambda \cdot (BUB - LB(\alpha^l, \beta^l)) / (\sum_{i \in I} (\gamma_i^l)^2 + \sum_{k \in K} (\eta_k^l)^2)$ is the step size at iteration l . $LB(\alpha^l, \beta^l)$ is the lower bound of the TECFLP-DSS (see subchapter 4.3.1) at iteration l . λ is a parameter in the interval $(0, 2]$, which is halved if the BLB found so far has not been improved for a given number N_{Lag} of consecutive iterations.

Let L_{Lag} be the maximum number of iterations and ε_{Lag} be a positive small scalar, the subgradient optimization procedure for the TECFLP-DSS is shown in detail in Algorithm 4.1.

Algorithm 4.1: Subgradient optimization procedure for the TECFLP-DSS

Step 1: Initialize ε_{Lag} , L_{Lag} and λ_0 , where λ_0 is a parameter in the interval $(0, 2]$. Set $BUB := +\infty$, $BLB :=$

$$-\infty, \lambda := \lambda_0, \alpha_i^0 := 0, \forall i \in I, \beta_k^0 := 0, \forall k \in K \text{ and } l := 1.$$

Step 2: Solve the subproblems $LR_1(\alpha^l)$ and $LR_2(\alpha^l, \beta^l)$ to optimality. Let $LB = LR(\alpha^l, \beta^l)$. If $LB > BLB$,

4. Two-echelon capacitated facility location problem with depot size selection

then set $BLB := LB$. If no improvement of BLB can be detected in N_{Lag} successive iterations, then set $\lambda := \lambda/2$.

Step 3: Construct a feasible solution of the TECFLP-DSS based on the current Lagrangean lower bound solution (Chapter 4.3.3) and let UB be the objective value of this feasible solution. If $UB < BUB$, then set $BUB := UB$.

Step 4: If $l > L_{Lag}$ and $\lambda < \varepsilon_{Lag}$, stop. The dual solution corresponding to the BLB is regarded as the optimal dual solution and the solution corresponding to the BUB is regarded as the optimal primal solution.

Step 5: Update α_i^l for $\forall i \in I$ and β_k^l for $\forall k \in K$ according to the formula (4-20) and (4-21) respectively.

Step 6: Set $l := l + 1$ and return to Step 2.

4.3.3 Feasible solution construction

Feasible solutions are used to calculate the step size in the subgradient optimization procedure. A feasible solution of the TECFLP-DSS can be constructed by repairing the Lagrangean relaxation solutions at each iteration of the procedure, i.e., at iteration l . Let $\varphi_{jsk} = h_{js} + c_{jk}$ be the cost of assigning customer k to a depot j with size s . Define a regret value of an unassigned customer k as the difference between the second smallest and the smallest φ_{jsk} values, among all of the opened depots whose residual capacities are no less than d_k . Partition the set of the customers K into three subsets:

$$K_0 = \{k \in K : \sum_{j \in J} \sum_{s \in S_j} z_{jsk}^l = 0\},$$

$$K_1 = \{k \in K : \sum_{j \in J} \sum_{s \in S_j} \hat{z}_{jsk}^l = 1\} \text{ and}$$

$$K_2 = \{k \in K : \sum_{j \in J} \sum_{s \in S_j} \hat{z}_{jsk}^l \geq 1\},$$

such that $K_0 \cup K_1 \cup K_2 = K$. The procedure for constructing a feasible solution is shown in Algorithm 4.2.

Algorithm 4.2: Constructing feasible solution

Step 1: Open all of the plants i if $\hat{u}_i^l = 1$.

Step 2: Open all of the depots j with s if $\hat{v}_{js}^l = 1$. If the total capacity of the opened depots is not enough to satisfy the customers' demands, stop.

Step 3: Assign the customers $k \in K_1$ to the corresponding opened depot j .

Step 4: Assign the customers $k \in K_2$ to the opened depot j with the smallest cost φ_{jsk} .

Step 5: Repeat Step 5.1-Step 5.2 until all the customers of K_0 are assigned or a customer is failed to assigned to any depot.

Step 5.1: For all of the unassigned customer, find their lowest and second lowest φ_{jsk} among those opened

4. Two-echelon capacitated facility location problem with depot size selection

depots with sufficient residual capacity and compute their regret values. If no depot has the sufficient residual capacity has been find for a customer, stop.

Step 5.2: Choose the customer with the maximum regret value and assign it to the depot j with size s where φ_{jsk} value is lowest.

Step 6: Close the depots that have no customer assigned to them.

Step 7: Solve the corresponding transportation problem to determine the product flows from plants to depots

Step 8: Close all of the plants whose products are not flowing out to any depot.

Note that the sum of capacities of these opened plants is enough to satisfy the customers' demands since we have the constraint (4-7), $\sum_{i \in I} cp_i \cdot \hat{u}_i^l \geq \sum_{k \in K} d_k$ in the $LR_1(\alpha)$. If the total capacities of the opened depots is not enough to satisfy the customers' demands or if no depot has sufficient residual capacity for a customer, no feasible solution is constructed in the iteration l . If plants with enough capacity have been opened and if feasible customer-depot assignments have been obtained, then the product flow from the plants to the depots can be determined by solving a transportation problem. In this transportation problem, the opened plants and depots are viewed as the source nodes and the destination nodes respectively, the plants capacities and the customers' demands assigned to the depots are viewed as the supply capacities and destination demands respectively. To save the fixed opening cost, the plants from which without product flowing out and the depots to which no customers are assigned are closed at the end.

4.4 Hybrid variable neighborhood tabu search algorithm for the TECFLP-DSS

Variable Neighborhood Search (VNS), introduced by Mladenović and Hansen (1997), is a generic local search methodology, whose basic idea is to apply a systematic change of neighborhoods within a local search algorithm. The basic VNS framework consists of three steps: shaking, local search and move or not. The VNS has since been successfully applied in a variety of combinatorial optimization problems, such as the arc routing problem (Hertz and Mittaz, 2001), the linear ordering problem (Garcia et al., 2006), the minimum spanning tree problem (Naji-Azimi et al., 2010) and the p-median problem (Ilić et al., 2010), etc.

As stated in chapter 3, the TS is a local search based metaheuristic. The TS explores the solution space by moving from the current solution to another in its neighborhoods. A candidate solution is accepted even if this solution deteriorates the function value, according to an aggressive admission criterion to avoid getting trapped in local optima. To prevent the possibility of cycling, a tabu list is introduced to forbid moves from recently visited solutions for several iterations. However, forbidden moves can be overridden by some aspiration criteria. Finally, the TS terminates when stopping criteria are met. The TS has been widely applied in various combinatorial optimization problems, such as job shop scheduling (Hertz and Widmer, 1996), assignment problem (Díaz and Fernández, 2001) and vehicle routing problem (Gendreau and Hertz, 1994),

etc.

The basic VNS sometimes meets difficulties to escape from the local optimum although it explores solution space by applying a systematic change of neighborhoods and moves at random from one solution to another (shaking). On the other hand, the TS has no such difficulties since it escapes the local optimum by using a tabu list to avoid the recently visited solutions to be revisited. To make use of the potentiality of the systematic changes of the neighborhood structures of the VNS and the efficiency of the TS to move out from a local optimum, the hybrid of the VNS and the TS has been applied in many combinatorial optimization problems in the literature, such as the scheduling problem (Liao and Cheng, 2007), the vehicle routing problem (Belhaiza et al., 2014) and the location routing problem (Escobar et al., 2014).

In this chapter, we proposed a hybrid variable neighborhood tabu search algorithm (HVNTS) to improve the best solution found in the Lagrangean relaxation approach.

4.4.1 Moves and neighborhoods definitions

In the implementation of the HVNTS, moves are only based on the customer-depot assignment. Note that a solution ζ of the TECFLP-DSS consists of u, x, v and z . Define $\zeta = (v, z)$ be the v and z . Two kinds of moves are used: *shift* that reassigns one customer from one depot to another, *swap* that interchanges the assignments of two customers that are currently assigned to two different depots. Accordingly, the neighborhoods $N_{shift}(\zeta)$ and $N_{swap}(\zeta)$ are defined as the set of feasible solutions that can be attained from the solution ζ by performing a shift move and a swap move, respectively.

4.4.2 Tabu list

A tabu list (TL) is used in the implementation of the HVNTS to prevent the recently visited solutions from being revisited. The element (k, j) of the TL records the last iteration number that it will be forbidden to assign the customer k to the depot j . If a customer k assigned to a depot j is reassigned to other depots, the assignment of the customer k to the depot j will be forbidden in the next t iteration. The parameter t is randomly selected from $[T_{min}, T_{max}]$.

4.4.3 The steps of the HVNTS

Define $F(\zeta)$ as the objective function of ζ and $f(\zeta)$ as the objective function of ζ . In the implementation of the HVNTS, we focused on improving ζ . If a better ζ is found, the flows x are determined by solving a transportation problem to obtain a new solution. In this transportation problem, the opened plants and depots are viewed as the source nodes and the destination nodes respectively, the plants capacities and the customer demands assigned to the depots are seen as the supply capacities and destination demands respectively.

The HVNTS follows the framework of the basic VNS and uses TS as the local search algorithm within

4. Two-echelon capacitated facility location problem with depot size selection

the VNS. Defined the neighborhood structures $N_l(\zeta)$, $l := 1, \dots, L_{\max}$, as the solutions that can be obtained by reassigning l customers of the solution ζ . Set the incumbent solution ζ^* as the best solution ζ found in the Lagrangean relaxation approach and $l := 1$, the HVNTS improves this incumbent solution until all of the neighborhood structures of the incumbent solution are completely explored. More specifically, the improvement of the incumbent solution is done in a loop. This loop includes a shaking phase, a TS phase and a move-or-not phase. The steps of the HVNTS are described in detail in algorithm 4.3.

Algorithm 4.3: Steps of the HVNTS

- Step 1: (Initialize) define the neighborhood structures $N_l(\zeta)$, $l := 1, \dots, L_{\max}$, initialize the incumbent solution ζ^* as the best solution ζ found in the Lagrangean relaxation approach, set $l := 1$.
- Step 2: (Shaking phase) while $l < L_{\max}$, let ζ be the v and z of the incumbent solution ζ^* , randomly reassign l customers of the ζ subject to depot capacity constraints to generate a new ζ' .
- Step 3: (TS phase) apply the TS to improve the ζ' generated in step 2 to obtain a new ζ'' .
- Step 4: (Move-or-not phase) if $f(\zeta'') > f(\zeta)$, set $l := l + 1$. If $f(\zeta'') < f(\zeta)$, solve the corresponding transportation problem composed of u and ζ'' to determine the new flows x' from the plants to the depots and thus to obtain a new solution ζ' composed of u , x' and ζ'' . If $F(\zeta') < F(\zeta^*)$, update the incumbent solution ζ^* with ζ' and set $l := 1$, otherwise set $l := l + 1$.
-

At the beginning of each shaking phase, the ζ is set as the v and z of the incumbent solution ζ^* . Then the shaking phase randomly reassign l customers of the ζ to generate a random ζ' , which enables us to explore neighborhoods farther away from the incumbent solution. Note, in the shaking phase, the TL is also used to avoid looping back in the search process of the TS. If a customer k assigned to a depot j is reassigned to other depots, the value of element (k, j) is set to t , which means that assigning the customer k the depot j will be forbidden for the first t iterations in the TS phase.

The TS phase improves the randomly generated solution ζ' to find a local optimal solution ζ'' . The TS starts with the solution ζ' and terminates if a maximum number M_{\max} of iterations is reached or the ζ'' is not improved in a successive number N_{\max} of iterations. In the search process of the TS, the best accept strategy is applied. At each iteration m , the save cost (SC) of all of the shift and swap moves that will not lead to infeasible assignment with respect to depot capacity in the neighborhood of the ζ' is computed first. Then the best admissible move (with the smallest SC) is performed. If a customer k assigned to a depot j is reassigned to other depots at iteration m , the value of element (k, j) of the TL is set to $m + t$, which means that assigning the customer k the depot j will be forbidden for the next t iterations. The aspiration is based on the SC , $f(\zeta')$ and $f(\zeta'')$. If the value SC of a move plus $f(\zeta')$ is less than $f(\zeta'')$, it performed in spite that it leads to tabu customer-depot assignment. Otherwise it is accepted only when it does not lead to tabu customer-depot assignment.

4.5 Computational results

The proposed Lagrangean relaxation approach and the HVNTS are coded in C++. The numerical experiments are carried out on a personal computer with Intel® Core™ 2 2.33 GHz Quad CPU Q8200 and 2 G RAM under a Microsoft Windows 7 operating system. In section 5.1, we describe the way to generate random instances. In section 5.2, 245 instances with different problem parameters, such as the ratios of plant capacity to customer demand, the ratios of depot capacity to customer demand and the number of plant size, are tested to evaluate the solution quality and speed of the Lagrangean relaxation approach and the HVNTS.

4.5.1 Test instances

Based on the instance generation of the CFLP (Cornuejols et al., 1991) and the TSCFLP (Klose, 1999), the instances are generated in the following way. The coordinates of potential plants, potential depots and customers are randomly selected from a unit square. The unit transportation costs are 10 times the Euclidean distance between the locations. Let $U[a, b]$ denote a uniform distribution in interval $[a, b]$. The demand d_k of customer $k \in K$ is generated from $U[5, 35]$. The capacity cp_i for $i \in I$ is generated from $U[10, 160]$ and scaled by using the ratio $r_{cpd} = \sum_{i \in I} cp_i / \sum_{k \in K} d_k$. Let $cd_{jp} \leq cd_{jq}$ if $p \leq q$, we first generate $cd_{j|S_j|}$ for each depot $j \in J$ from $U[10, 160]$ and then scale the capacities using the ratio $r_{cdd} = \sum_{j \in J} cd_{j|S_j|} / \sum_{k \in K} d_k$. For each $s < |S_j|$, cd_{js} is set to $s \cdot cd_{j|S_j|} \cdot \sigma / |S_j|$, where σ is a parameter randomly selected from $U[0.9, 1.1]$. To reflect the depots' economies of scale, the unit handling cost for a smaller depot is assumed to be larger than that for a bigger depot at the same depot. For each depot $j \in J$, we first generate the unit handling cost h_{j1} from $U[5, 7]$. Then, for any $s > 1$, h_{js} is obtained by multiplying the handling cost $h_{j(s-1)}$ by a random parameter selected from $U[0.9, 0.95]$. The fixed opening costs for a plant or each size of a depot is obtained by multiplying its capacity by a parameter selected from $U[20, 25]$.

4.5.2 Results

In our implementation of the subgradient optimization procedure, the parameters are set as follows: $L_{Lag} = 3000$, $\varepsilon_{Lag} = 10^{-4}$, $N_{Lag} = 40$ and $\lambda_0 = 1.5$. For the HVNTS, the parameters T_{min} and T_{max} are set to 20 and 25 respectively, the L_{max} is set to 3, M_{max} is set to 2000, N_{max} is set to 200. The CPLEX version 12.5 with default setting is used as the MIP solver.

Let UB_{Lag} be the *BUB* found by the Lagrangean relaxation approach, UB_H be the *BUB* found by the HVNTS, UB_{C1} be the *BUB* found by CPLEX without time limitation, UB_{C2} be the *BUB* found by CPLEX within time limit T_{LagH} and LB_{Lag} be the *BLB* found by the Lagrangean relaxation approach. The computational results are shown in Tables 4.1-4.4. For each instance set, five instances are generated. To simplify the presentation, the column headings are as follows:

4. Two-echelon capacitated facility location problem with depot size selection

$ I \times J \times K $	the number of the plants, the depots and the customers respectively
G_{Lag}	the gaps between UB_{Lag} and LB_{Lag} , i.e., $(UB_{Lag} - LB_{Lag}) / LB_{Lag} \times 100$
G_H	the gaps between UB_H and LB_{Lag} , i.e., $(UB_H - LB_{Lag}) / LB_{Lag} \times 100$
G_{HC1}	the gaps between UB_H and UB_{C1} , i.e., $(UB_H - UB_{C1}) / UB_{C1} \times 100$
G_{HC2}	the gaps between UB_H and UB_{C2} , i.e., $(UB_H - UB_{C2}) / UB_{C2} \times 100$
T_{Lag}	the CPU time used by the Lagrangean relaxation approach
T_{LagH}	the CPU time used by the Lagrangean relaxation approach and the HVNTS
T_{C1}	the CPU time of CPLEX without time limitation
Avg.	the average value of gaps or computational times for each instance set
Max.	the maximum value of gaps or computational times for each instance set

In table 4.1, in order to evaluate the solution quality of the proposed Lagrangean relaxation approach and the HVNTS, we compare the results of the Lagrangean relaxation approach and the HVNTS with those of the following two versions of CPLEX (c1 and c2). For the CPLEX c1, no time limit is imposed. That is the CPLEX c1 terminates itself if an optimal solution is found or an “*Out of memory*” error occurs. For the CPLEX c2, the time limit T_{LagH} is imposed. For the instances tested in Table 4.1, $r_{cpd} = 2.0$, $r_{cdd} = 2.0$ and $|S_j| = 3$. The experimental results show that CPLEX can find an optimal solution only for the instances of the set 1 and meets an “out of memory” error for the instances of the other sets.

It can be seen from the Table 4.1, the average gaps between the Lagrangean upper bound and lower bound range from 0.64% to 1.69% and the maximum gap is 2.14%. The gaps between the HVNTS upper bound and the Lagrangean lower bound range from 0.42% to 1.18% and the maximum gap is 1.60%. It is clear that the Lagrangean relaxation approach provide both a well upper bounds and a good lower bounds for the TECFLP-DSS and the HVNTS also performs well. Comparing with the CPLEX c1, the average gaps between the HVNTS upper bounds and the upper bounds found by the CPLEX c1 range from -0.63% to 0.41%. The gaps decrease as problem size increases and the HVNTS can provide better upper bounds than the CPLEX c1 for the large-sized instances, e.g., the gaps between the HVNTS upper bounds and upper bounds found by the CPLEX c1 for set 10 is -0.63%. In terms of computation time, the CPLEX c1 takes much more time than the Lagrangean relaxation approach and the HVNTS. The Lagrangean relaxation approach and the HVNTS only take several to hundreds of seconds of CPU time while the CPLEX c1 takes thousands of seconds. When compared with the CPLEX c2, the Lagrangean relaxation approach and the HVNTS is much more effective than the CPLEX c2 in that the average gaps between the HVNTS upper bounds and those of the CPLEX c2 range from -1.85% to -0.48%, the HVNTS upper bounds are much better than the CPLEX upper bounds for all of the instances.

Table 4.1: Computational results and comparisons of the HVNTS bounds with those of CPLEX

$ I \times J \times K $	$G_{Lag} (\%)$		$G_H (\%)$		$G_{HC1} (\%)$		$G_{HC2} (\%)$		$T_{LagH} (s)$		$T_{C1} (s)$	
	G_{Lag}	Avg.	G_H	Avg.	G_{HC1}	Avg.	G_{HC2}	Avg.	T_{LagH}	Avg.	T_{C1}	Avg.
	1.32		0.56		0.12		-0.34		4.3		19.4	
	1.28		1.13		0.52		-1.56		3.8		33.8	
5×10×40	2.07	1.69	1.70	1.16	0.70	0.40	0.67	-0.49	5.1	4.1	17.3	30.1
	1.64		1.18		0.29		-0.91		3.7		47.3	

4. Two-echelon capacitated facility location problem with depot size selection

	2.14		1.26		0.35		-0.35		3.7		32.8	
	1.56		1.16		0.38		-1.19		11.7		32321.9	
	1.16		1.00		0.35		-0.91		11.0		10448.2	
10×20×80	1.61	1.41	1.16	1.05	0.30	0.30	-1.23	-0.93	9.9	11.4	30039.0	20832.1
	1.30		0.99		0.42		-0.93		14.4		18335.1	
	1.41		0.93		0.03		-0.40		10.3		13016.3	
	1.46		1.03		0.30		-1.24		24.8		6688.6	
	1.02		0.77		0.18		-1.73		26.2		5065.8	
15×30×120	1.27	1.15	0.97	0.91	0.00	0.10	-1.23	-1.53	26.7	25.0	2869.6	4590.2
	1.06		0.94		0.01		-2.25		21.3		5425.5	
	0.96		0.85		0.03		-1.21		26.2		2901.6	
	1.10		0.74		0.16		-0.78		50.0		5573.0	
	1.03		0.65		0.13		-0.57		43.3		5966.7	
20×40×160	1.16	1.02	0.90	0.76	0.05	0.06	-1.06	-1.38	40.0	41.8	4924.3	4801.1
	0.88		0.72		-0.05		-1.21		35.9		3973.9	
	0.91		0.80		0.00		-3.28		39.7		3567.7	
	0.95		0.68		0.01		-1.80		65.6		4435.1	
	0.90		0.56		-0.12		-1.15		92.1		4682.3	
25×50×200	0.66	0.93	0.54	0.65	0.02	0.00	-1.98	-1.30	73.3	82.7	4517.3	4617.8
	1.04		0.66		0.13		-0.63		94.5		4956.4	
	1.09		0.80		-0.03		-0.94		88.1		4497.9	
	0.99		0.71		0.08		-0.90		112.9		6551.8	
	0.84		0.57		0.02		-1.38		128.1		6713.7	
30×60×240	0.75	0.86	0.50	0.55	-0.03	-0.03	-2.02	-1.77	117.7	116.9	7422.7	6318.3
	0.95		0.57		-0.04		-2.42		124.4		5307.6	
	0.76		0.38		-0.18		-2.12		101.2		5595.6	
	0.81		0.44		-0.12		-1.97		152.3		8026.6	
	0.65		0.34		-0.07		-1.29		140.8		8838.1	
35×70×280	0.87	0.83	0.45	0.45	-0.11	-0.08	-3.09	-1.81	165.4	167.4	7349.9	7743.5
	0.94		0.51		-0.06		-2.03		187.9		8495.6	
	0.90		0.53		-0.02		-0.65		190.5		6007.5	
	0.63		0.47		-0.03		-2.22		179.3		9971.1	
	0.73		0.43		-0.10		-1.55		228.4		11402.9	
40×80×320	0.84	0.76	0.50	0.45	-0.10	-0.13	-1.97	-1.50	231.9	250.2	9344.1	9601.5
	0.79		0.37		-0.19		-0.86		346.3		9875.6	
	0.80		0.48		-0.23		-0.88		265.1		7414.0	
	0.69		0.52		-0.38		-0.93		384.7		9503.9	
	0.66		0.30		-0.55		-0.81		343.8		5789.3	
45×90×360	0.75	0.70	0.41	0.45	-0.63	-0.57	-0.83	-0.86	295.9	340.6	5954.8	6625.8
	0.70		0.53		-0.62		-0.64		335.9		6213.5	
	0.71		0.47		-0.68		-1.12		342.9		5667.5	
	0.66		0.42		-0.87		-1.73		307.3		5924.0	
	0.59		0.33		-0.59		-0.92		338.3		5245.3	
50×100×400	0.60	0.64	0.33	0.38	-0.56	-0.67	-1.25	-1.29	460.0	373.5	5896.4	6135.8
	0.65		0.38		-0.66		-1.45		401.8		6711.2	
	0.70		0.44		-0.64		-1.10		360.2		6902.1	
Average	1.00		0.68		-0.06		-1.29					

In table 4.2, we report the performances of the Lagrangean relaxation approach and the HVNTS on

4. Two-echelon capacitated facility location problem with depot size selection

instances with different ratio r_{cpd} . For all the instances given in Table 2, $r_{cdd} = 2.0$ and $|S_j| = 3$. The average gaps between the Lagrangean upper bounds and lower bounds range from 0.59% to 1.11% and the maximum gap is 1.28%, the average gaps between the HVNTS upper bounds and the Lagrangean lower bounds range from 0.37% to 0.90% and the maximum gap is 0.97%, which indicate that the Lagrangean relaxation approach and the HVNTS perform well and they are effective for the instances with different ratio r_{cpd} . In addition, both the average gaps between the Lagrangean upper bounds and lower bounds and the average gaps between the TS upper bounds and the Lagrangean lower bounds increase for the instances of the same size as the ratio r_{cpd} increases, e.g., for the $50 \times 100 \times 400$ instances, the average gaps between the Lagrangean upper bounds and lower bounds are 0.59%, 0.63%, 0.64% and 0.71% for $r_{cpd} = 1.5, 2.0, 2.5$ and 3.0 respectively, and the average gaps between the HVNTS upper bounds and the Lagrangean lower bounds are 0.37%, 0.44%, 0.48% and 53% for $r_{cpd} = 1.5, 2.0, 2.5$ and 3.0 respectively. It can be concluded that the Lagrangean relaxation approach and the HVNTS are more effective for smaller ratio r_{cpd} than for larger ratio r_{cpd} .

Table 4.2: Computational results on the instances with different plant capacities

$ I \times J \times K $	r_{cpd}	$G_{Lag}(\%)$		$G_H(\%)$		$T_{Lag}(s)$		$T_H(s)$		$T_{LagH}(s)$	
		G_{Lag}	Avg.	G_H	Avg.	T_{Lag}	Avg.	T_H	Avg.	T_{LagH}	Avg.
25×50×200	1.5	0.82		0.44		42.4		30.3		72.6	
		0.97		0.65		59.8		40.7		100.5	
		0.76	0.86	0.43	0.58	64.7	58.7	25.0	32.3	89.7	91.0
		0.90		0.69		57.4		37.4		94.8	
		0.88		0.70		69.3		28.1		97.4	
25×50×200	2.0	1.15		0.66		42.8		17.9		60.8	
		0.93		0.61		47.3		17.0		64.3	
		1.01	0.93	0.59	0.55	51.7	51.9	37.6	21.4	89.3	73.3
		0.71		0.43		59.5		10.3		69.8	
		0.84		0.47		58.2		24.4		82.6	
25×50×200	2.5	1.15		0.80		63.6		26.2		89.8	
		0.94		0.80		61.3		21.3		82.6	
		1.21	1.01	0.80	0.71	48.3	58.3	13.5	21.1	61.8	79.4
		0.82		0.66		55.8		23.0		78.8	
		0.91		0.50		62.5		21.6		84.1	
25×50×200	3.0	1.22		0.88		61.1		22.5		83.6	
		0.92		0.73		59.5		18.8		78.2	
		0.99	1.11	0.81	0.84	60.3	57.0	10.9	16.4	71.2	73.4
		1.28		0.89		50.0		15.0		65.0	
		1.16		0.91		54.3		14.9		69.2	
35×70×280	1.5	0.76		0.45		128.0		33.3		161.3	
		0.89		0.60		110.2		36.7		147.0	
		0.71	0.74	0.42	0.43	113.5	113.3	46.2	43.7	159.7	156.9
		0.73		0.34		115.4		57.9		173.3	
		0.62		0.37		99.1		44.0		143.2	
35×70×280	2.0	0.64		0.40		112.7		34.2		150.8	
		0.69		0.44		118.6		45.6		164.2	
		0.82	0.79	0.58	0.53	91.5	272.9	64.4	46.1	155.9	158.8
		0.88		0.57		120.1		41.5		161.5	
		0.93		0.64		116.8		45.0		161.8	

4. Two-echelon capacitated facility location problem with depot size selection

35×70×280	2.5		0.95		0.66		121.9		30.5		152.4	164.6
			0.78		0.52		113.8		50.5		164.3	
			1.07	0.92	0.64	0.60	113.6	115.3	54.1	49.4	167.6	
			0.98		0.68		111.0		35.0		145.9	
			0.82		0.51		116.1		76.8		192.9	
35×70×280	3.0		1.14		0.68		104.2		65.7		169.9	161.1
			0.70		0.44		132.9		34.2		167.1	
			1.05	0.93	0.48	0.58	98.5	111.9	71.3	49.2	169.8	
			0.87		0.56		104.7		35.1		139.8	
			0.91		0.72		119.2		39.9		159.1	
50×100×400	1.5		0.62		0.34		331.8		52.9		384.7	447.1
			0.60		0.29		280.7		118.5		399.2	
			0.51	0.59	0.35	0.32	348.5	324.0	74.9	123.1	423.4	
			0.56		0.28		348.5		158.9		507.4	
			0.64		0.32		310.5		210.2		520.7	
50×100×400	2.0		0.63		0.40		294.2		124.3		418.5	392.9
			0.76		0.55		311.1		74.3		385.5	
			0.60	0.63	0.35	0.37	305.2	298.3	73.0	94.7	378.2	
			0.60		0.29		297.1		83.9		381.0	
			0.56		0.26		283.8		117.8		401.6	
50×100×400	2.5		0.51		0.34		318.7		94.2		412.9	421.9
			0.61		0.46		344.9		113.1		458.0	
			0.58	0.64	0.37	0.41	305.1	315.8	96.3	106.1	401.4	
			0.66		0.36		288.2		99.5		387.7	
			0.85		0.51		322.3		127.4		449.7	
50×100×400	3.0		0.64		0.41		277.0		149.4		426.4	408.0
			0.64		0.39		304.3		39.1		343.4	
			0.85	0.71	0.62	0.47	307.3	291.1	146.7	116.9	454.0	
			0.76		0.42		323.3		167.1		490.4	
			0.69		0.53		243.6		82.3		325.9	
Average			0.82		0.53							

The performances of the Lagrangean relaxation approach and the HVNTS on the instances with different ratio r_{cdd} are reported in Table 4.3. For all the instances given in Table 4.3, $r_{cpd} = 2.0$ and $|S_j| = 3$. The average gaps between the Lagrangean upper bounds and lower bounds range from 0.63% to 1.00% and the maximum gap is 1.23%, the gaps between the HVNTS upper bounds and the Lagrangean lower bounds range from 0.43% to 0.72% on average and the maximum gap is 0.91%. It is clear that the Lagrangean relaxation approach and the HVNTS perform well and they are effective for the instances with different ratio r_{cdd} . It can be seen from Table 4.3 that the ratio r_{cdd} does not have a significant influences on the solution quality and solution time, e.g., for the 50×100×400 instances, the average gaps between the Lagrangean upper bounds and lower bounds are 0.63%, 0.67%, 0.68% and 0.67% for $r_{cdd} = 1.5, 2.0, 2.5$ and 3.0 respectively, the average gaps between the HVNTS upper bounds and the Lagrangean lower bounds are 0.43%, 0.45%, 0.45% and 0.49% for $r_{cdd} = 1.5, 2.0, 2.5$ and 3.0 respectively, and the average CPU time is 761.9, 810.3, 658.5 and 774.0 seconds for $r_{cdd} = 1.5, 2.0, 2.5$ and 3.0 respectively.

Table 4.3: Computational results on the instances with different depot capacities

$ I \times J \times K $	r_{cdd}	G_{Lag} (%)		G_{TS} (%)		T_{Lag} (s)		T_H (s)		T_{LagH} (s)	
		G_{Lag}	Avg.	G_{TS}	Avg.	T_{Lag}	Avg.	T_H	Avg.	T_{LagH}	Avg.

4. Two-echelon capacitated facility location problem with depot size selection

			0.62		0.35		46.1		16.5		62.6	
			0.93		0.47		72.5		13.1		85.7	
25×50×200	1.5		1.16	0.92	0.63	0.58	59.6	57.3	20.9	16.8	80.4	74.1
			0.85		0.74		58.1		9.2		67.3	
			1.01		0.73		50.3		24.1		74.3	
			1.11		0.76		50.9		27.8		78.7	
			0.84		0.46		49.7		13.6		63.4	
25×50×200	2.0		0.88	0.89	0.49	0.59	53.1	50.8	10.2	17.3	63.3	68.0
			0.79		0.59		50.5		16.2		66.8	
			0.83		0.65		49.5		18.5		68.0	
			1.02		0.48		46.6		13.9		60.6	
			0.99		0.66		56.4		24.0		80.5	
25×50×200	2.5		1.02	1.00	0.76	0.62	60.3	56.1	14.2	17.9	74.5	74.0
			1.23		0.77		51.3		25.0		76.3	
			0.73		0.45		65.7		12.4		78.1	
			0.63		0.40		46.7		15.2		61.9	
			1.21		0.89		54.3		29.0		83.3	
25×50×200	3.0		0.74	0.89	0.45	0.57	59.6	52.0	15.7	17.6	75.4	69.7
			0.65		0.47		50.7		12.8		63.4	
			1.19		0.63		49.0		15.5		64.5	
			0.87		0.53		107.3		27.0		134.3	
			0.94		0.54		118.5		37.7		156.2	
35×70×280	1.5		0.82	0.83	0.55	0.51	104.8	118.6	40.5	43.4	145.3	162.0
			0.81		0.50		122.6		66.2		188.8	
			0.71		0.43		139.5		45.8		185.4	
			0.90		0.53		114.4		92.3		206.6	
			0.69		0.44		107.0		41.9		148.9	
35×70×280	2.0		1.00	0.85	0.74	0.56	104.2	106.0	69.1	58.2	173.4	164.2
			0.62		0.40		105.3		43.2		148.5	
			1.05		0.67		99.0		44.5		143.5	
			0.81		0.49		95.7		23.6		119.3	
			0.95		0.55		107.9		34.0		141.8	
35×70×280	2.5		0.67	0.81	0.41	0.50	116.4	107.1	40.2	37.3	156.6	144.4
			0.78		0.50		97.4		49.5		146.9	
			0.86		0.56		118.0		39.2		157.2	
			0.89		0.70		105.8		82.5		188.3	
			0.92		0.56		118.0		39.8		157.8	
35×70×280	3.0		0.89	0.80	0.65	0.56	100.9	109.2	26.8	47.5	127.7	156.6
			0.73		0.43		111.2		46.6		157.7	
			0.60		0.43		110.0		41.6		151.6	
			0.59		0.33		246.9		168.0		414.9	
			0.71		0.42		256.1		143.6		399.7	
50×100×400	1.5		0.60	0.63	0.35	0.36	333.6	284.6	121.8	137.9	455.4	422.5
			0.69		0.44		256.1		146.6		402.7	
			0.57		0.25		330.1		109.6		439.7	
			0.71		0.40		255.8		229.0		484.8	
			0.61		0.43		280.3		184.1		464.4	
50×100×400	2.0		0.71	0.67	0.45	0.41	291.4	287.9	61.1	151.8	352.5	439.7
			0.70		0.42		318.7		209.9		528.6	
			0.61		0.34		293.2		74.9		368.1	

4. Two-echelon capacitated facility location problem with depot size selection

50×100×400	2.5		0.73	0.46		252.3		143.4	402.0	1181.9
			0.77	0.46		298.8		91.2	390.1	
		0.68	0.40	0.42	280.6	284.8	129.7	117.2	410.3	
			0.52	0.30		317.6		129.9	447.5	
			0.65	0.45		274.5		91.9	366.4	
50×100×400	3.0		0.74	0.47		265.9		136.4	402.3	405.3
			0.70	0.42		255.6		227.9	483.5	
		0.67	0.41	0.45	297.8	265.2	80.0	140.2	377.8	
			0.58	0.43		276.0		143.3	419.3	
			0.66	0.49		230.6		113.2	343.7	
Average			0.80	0.51						

In Table 4.4, we provide an analysis of the performances of the proposed Lagrangean relaxation approach and the HVNTS on the instances with different numbers of depot size. For all the instances given in Table 4.4, $r_{cpd} = 2.0$ and $r_{cdd} = 2.0$. The Lagrangean relaxation approach and the HVNTS are effective in that the average gaps between the Lagrangean upper bounds and lower bounds range from 0.56% to 0.97% and the maximum gap is 1.15%, the average gaps between the HVNTS upper bounds and the Lagrangean lower bounds range from 0.41% to 0.73% and the maximum gap is 0.93%. The number of the depot size does not have a significant influences on the solution quality, e.g., for the 50×100×400 instances, the average gaps between the HVNTS upper bounds and the Lagrangean lower bounds are 0.47%, 0.46%, 0.47%, 0.41% and 0.43% for $|S_j| = 2, 3, 4, 5$ and 6 respectively. However, the computational time of the Lagrangean relaxation approach and the HVNTS increases regularly as the number of the depot size increases, e.g., for the 50×100×400 instances, the average CPU time is 623.5, 670.7, 737.9, 946.9 and 1040.6 seconds for $|S_j| = 2, 3, 4, 5$ and 6 respectively.

Table 4.4: Computational results on the instances with different numbers of depot size

$ I \times J \times K $	$ S_j $	$G_{Lag}(\%)$		$G_H(\%)$		$T_{Lag}(s)$		$T_H(s)$		$T_{LagH}(s)$	
		G_{Lag}	Avg.	G_H	Avg.	T_{Lag}	Avg.	T_H	Avg.	T_{LagH}	Avg.
25×50×200	2		0.92		0.59		32.4		10.8		43.2
			0.99		0.60		36.3		10.8		47.1
		0.97	0.58	0.62	32.9	33.9	24.9	18.7	57.8	52.6	
			0.76		0.45		32.9		17.8		50.6
			1.05		0.91		35.1		29.3		64.5
25×50×200	3		0.98		0.73		52.7		20.1		72.8
			0.59		0.45		53.7		13.1		66.8
		0.94	0.70	0.63	58.8	54.8	12.5	15.9	71.3	70.7	
			1.09		0.60		50.8		11.2		61.9
			1.11		0.65		57.9		22.7		80.6
25×50×200	4		0.73		0.35		66.5		12.3		78.7
			0.99		0.57		73.2		19.9		93.1
		0.86	0.46	0.51	70.3	71.6	16.3	18.5	86.6	90.1	
			0.72		0.53		68.1		17.7		85.9
			1.06		0.65		79.9		26.1		106.0
25×50×200	5		0.82		0.41		80.7		12.3		93.1
			1.09		0.57		102.5		14.3		116.7
		0.87	0.55	0.53	107.4	98.8	19.5	19.0	126.9	117.8	
			1.03		0.76		107.5		33.7		141.2

4. Two-echelon capacitated facility location problem with depot size selection

			0.62	0.35		95.9		15.1		111.0	
			0.90	0.55		81.8		20.3		102.1	
			0.82	0.46		111.3		19.6		130.9	
25×50×200	6	0.88	0.53	0.50	121.1	107.7	17.2	19.5	138.3	127.2	
			0.91	0.44		118.7		27.5		146.2	
			0.94	0.52		105.4		13.1		118.5	
			0.73	0.55		94.4		46.6		141.0	
			0.76	0.47		82.0		67.4		149.4	
35×70×280	2	0.79	0.62	0.54	84.0	87.0	111.2	56.5	195.1	143.4	
			0.63	0.42		91.2		34.3		125.4	
			0.95	0.65		83.3		22.9		106.2	
			0.78	0.56		118.0		51.2		169.1	
			0.62	0.35		117.3		56.5		173.8	
35×70×280	3	0.83	0.77	0.55	114.2	111.6	63.1	52.4	177.3	163.9	
			0.75	0.43		96.8		49.4		146.2	
			0.96	0.62		111.5		41.8		153.3	
			0.82	0.41		122.6		48.2		170.7	
			0.76	0.63		154.0		25.6		179.6	
35×70×280	4	0.82	0.60	0.55	176.6	159.2	50.5	43.3	227.1	202.6	
			0.75	0.52		162.4		58.1		220.5	
			0.75	0.58		180.5		34.4		214.9	
			0.80	0.52		179.7		42.1		221.8	
			0.93	0.67		238.1		45.7		283.8	
35×70×280	5	0.82	0.55	0.58	254.9	215.2	49.7	44.2	304.6	259.4	
			0.71	0.51		211.2		36.4		247.6	
			0.88	0.64		192.1		47.0		239.0	
			0.95	0.64		257.9		70.0		327.9	
			0.91	0.52		260.2		45.9		306.2	
35×70×280	6	0.86	0.63	0.53	284.8	279.3	69.7	56.7	354.5	336.0	
			0.53	0.37		274.7		43.3		318.0	
			0.91	0.47		318.8		54.4		373.3	
			0.64	0.32		173.4		77.9		251.3	
			0.46	0.23		212.9		84.6		297.5	
50×100×400	2	0.66	0.45	0.40	195.6	195.9	161.8	128.9	357.4	324.8	
			0.77	0.43		206.5		204.1		410.6	
			0.76	0.54		191.0		116.2		307.2	
			0.73	0.42		286.5		109.4		395.8	
			0.70	0.47		287.5		129.6		417.1	
50×100×400	3	0.61	0.42	0.38	270.1	282.1	116.0	100.4	386.1	382.5	
			0.43	0.35		323.5		65.5		389.1	
			0.47	0.23		242.9		81.7		324.6	
			0.75	0.46		393.9		165.3		559.2	
			0.59	0.35		353.5		47.5		401.0	
50×100×400	4	0.63	0.39	0.41	369.3	363.6	43.2	92.1	412.6	455.7	
			0.67	0.47		349.6		56.7		406.3	
			0.58	0.38		351.9		147.6		499.5	
			0.72	0.35		477.3		200.0		677.3	
			0.52	0.28		468.6		91.9		560.6	
50×100×400	5	0.61	0.38	0.34	510.1	480.4	125.3	136.5	635.4	616.9	
			0.64	0.41		435.0		189.3		624.3	

4. Two-echelon capacitated facility location problem with depot size selection

		0.50		0.30		510.8		76.2		587.0	
		0.64		0.34		491.0		74.5		565.5	
		0.68		0.36		496.5		128.1		624.6	
50×100×400	6	0.64	0.66	0.32	0.36	630.8	558.1	175.9	110.4	806.8	668.5
		0.75		0.45		665.3		89.5		754.8	
		0.58		0.35		506.8		84.1		590.9	
Average		0.79		0.50							

4.6 Conclusions

In this chapter, we concentrate on the TECFLP-DSS where each depot has several size exhibiting different capacities. The unit handling cost for a larger size of a depot is assumed to be smaller than those of the smaller sizes of the same depot to model the economies of scale. This problem allow us to deal with both different sizes for depots and different handling costs at different levels of handling at a depot. A mixed integer programming model is formulated. This extended model can then simultaneously determine the locations and sizes of the plants, the locations of the depots, the product flows from the plants to the depots and the assignments of the customers to the depots to satisfy the customers' demands. The TECFLP-DSS is NP-hard in strong sense. A Lagrangean relaxation approach and a HVNTS are proposed for its resolution. First the Lagrangean relaxation approach is used to find good lower and upper bounds, and then the HVNTS is designed to improve the best upper bound found in the Lagrangean relaxation approach. The numerical experiments on 245 randomly generated instances indicate that the proposed Lagrangean relaxation approach and the HVNTS can provide high quality lower bounds and upper bounds to the TECFLP-DSS. The average gaps are not greater than 1.16%, with 1.70% at a maximum. In addition, instances with different parameters, such as the ratios of plant capacity to customer demand, the ratios of depot capacity to customer demand and the number of depot size, are tested to evaluate the robustness of the Lagrangean relaxation approach and the HVNTS. The computational results indicate that the proposed Lagrangean relaxation approach and HVNTS are effective for the instances with different parameters and can solve the instances that have up to 50 potential plants, 100 depots with 6 possible sizes each and 400 customers in a reasonable time.

The Lagrangean relaxation approach and HVNTS work very well and can provide good lower and upper bounds for our problem. However, some new ideas on solving the problems could be investigated, such as adding valid inequalities to accelerate the solution process, designing improvement strategies for the Lagrangean relaxation approach or the HVNTS. Another direction is to design a cut-and-solve (Zhang et al. 2006) based Lagrangean relaxation approach for the TECFLP-DSS.

Chapter 5

Two-echelon capacitated facility location problem with plant and depot size selection

5.1 Introduction

In this chapter, we study a two-echelon capacitated facility location problem with plant and depot size selection (TECFLP-PDSS), in which the sizes of the plants and depots are considered simultaneously. The TECFLP-PDSS is also an extension of the TSCFLP. In this problem, we simultaneously locate plants and depots, and select sizes for the located plants and depots, where each plants in the first stage has several potential sizes exhibiting different capacities. Each depot in the second stage has a several potential sizes exhibiting different capacities and is supplied by multiple plants. Each customer in the third stage is serviced by only one depot. This extended model will not allow us to deal with different sizes for plants and depots, but also with different production cost at different levels of production at a plant and handling costs at different levels of handling at a depot. The objective of this problem is to determine simultaneously the locations and sizes of the plants, the locations and sizes of the depots, the product flows from the plants to the depots and the assignments of the customers to the depots to satisfy the customers' demands.

As in the TECFLP-PSS and TECFLP-DSS, the fixed opening cost for a larger size of a plant is larger than those of the smaller sizes of the same plant and the fixed opening cost for a larger size of a depot is larger than those of the smaller sizes of the same depot. The unit production cost for a larger size of a plant is smaller than those of the smaller sizes of the same plant and the unit handling cost for a larger size of a depot is smaller than those of the smaller sizes of the same depot to model the economies of scale. The distinguishing features of the TECFLP-PDSS are: 1) there are several sizes for both potential plants and depots that can be opened, 2) both production cost at a plant and handling cost at depot is taken into account specifically since these costs cannot be merged with other linear connection costs like they are done in the traditional facility location model.

The TECFLP-PDSS can be seen as an extension of the TECFLP-PSS or TECFLP-DSS and is NP-hard in strong sense. Thus we concentrate on finding good lower and upper bounds for it. For this problem, we present a mixed integer programming model and a Lagrangean relaxation approach to achieve efficient lower and upper bounds. A hybrid simulated annealing tabu search algorithm (HSATS) is designed to further improve the best upper bound found by the Lagrangean relaxation approach. To solve the dual problem arising in the Lagrangean relaxation approach, a subgradient optimization method is used. The Lagrangean relaxation problem can be decomposed into two subproblems, one can be solved to optimality by inspections and another one can be decomposed further into the classical 0-1 knapsack problem which can be exactly solved in a very reasonable time by using the MINKNAP developed by Pisinger (1995). We construct feasible solution and find an upper bound by repairing the Lagrangean relaxation solutions. The feasible solution construction process consists of three stages: 1) open plants and select their sizes, 2) open depots, select their sizes and determine the customer-depot assignments, 3) determine the product flows from the plants to the depots. The HSATS focus on improving the customer-depot assignments. After the HSATS, the optimal product flows are determined by solving a transportation problem using commercial solver CPLEX.

To evaluate the general performance of the Lagrangean relaxation approach and HSATS, 50 instances

with different problem size are tested. The results of the gaps between the Lagrangean upper bounds and lower bounds, the upper bounds obtained by the HSATS and Lagrangean lower bounds, the upper bounds obtained by the HSATS and those provided by commercial MIP solver CPLEX are reported. The results demonstrate that the Lagrangean relaxation approach and HSATS are effective for the TECFLP-PDSS since the gaps between the upper bounds and those of the CPLEX are less than 1.75% on average and the CPU time required by the Lagrangean relaxation and HSATS is much less than that of the CPLEX. In addition, 270 instances with different sizes and different parameters, such as the ratio of plant capacity to customer demand, the ratio of depot capacity to customer demand and the number of plant size, are randomly generated and tested to evaluate the robustness of the Lagrangean relaxation approach and HSATS. The computational results show that the Lagrangean relaxation approach and HSATS perform well. All of the instances can be solved in a reasonable time with small gaps, even for instances that have up to 50 potential plants with 6 possible sizes each, 100 potential depots with 6 possible sizes each, and 400 customers.

The rest of this chapter is organized as follows. In Section 5.2, the mixed integer programming model is developed for the TECFLP-PDSS. In Section 5.3, the Lagrangean relaxation approach is proposed to achieve lower and upper bounds. In Section 5.4, the HSATS is proposed to improve the best upper bounds found in the Lagrangean relaxation approach. In Section 5.5, we evaluate the proposed algorithms on randomly generated instances. Conclusions are drawn in Section 5.6.

5.2 Problem formulation

Given a set of potential plants, a set of potential depots, each plant and depot has several possible sizes exhibiting different capacities, and a set of customers with demands, the aim of the TECFLP-PDSS is to select a set of plants and a set of depots to open, select a size for each opened plant and depot, determine the product flows from the plants to the depots and assign the customers to the opened depots to serve the customers at a minimum total cost. This cost includes the fixed opening costs of the facilities, the producing costs at the plants, the handling costs at the depots, the transportation costs from the plants to the depots and the assignment costs of the customers. The structure of the TECFLP-PDSS is presented in Fig. 5.1, where the first or upper-most stage is the plants, each plant has several sizes, the second or central stage is the depots, each depot has several sizes, and the third stage is the customers.

In the TECFLP-PDSS, each size of a plant associates with a capacity cp , a fixed opening cost fp and a unit production cost p . The fixed opening cost for a larger size of a plant is larger than those of the smaller sizes of the same plant. The unit production cost p for a larger size of a plant is smaller than those of the smaller sizes of the same plant. An example of the cost function including the fixed opening cost and the production cost of a plant is illustrated in Fig. 3.2. in Chapter 3. Each size of a depot associates with a capacity cd , a fixed opening cost fd and a unit handling cost h . The fixed opening cost for a larger size of a depot is larger than those of the smaller sizes of the same depot. The unit handling cost h for a larger size of a depot is smaller than those of the smaller sizes of the same depot. An example of the cost function including the fixed opening cost and the handling cost of a depot is illustrated in Fig. 4.2 in Chapter 4.

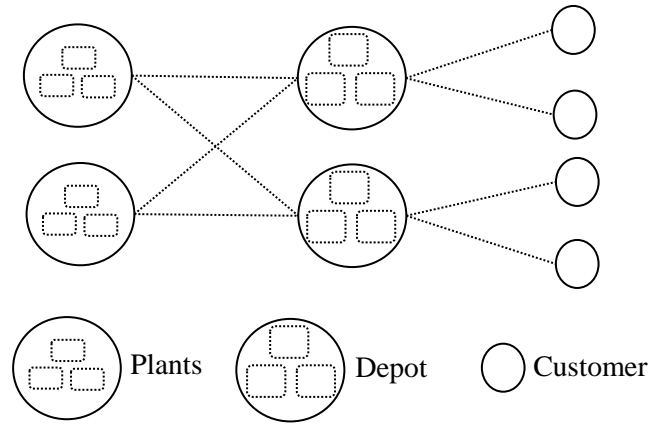

Fig. 5.1 The structure of the TECFLP-PDSS

To formulate the TECFLP-PDSS, the notations and decision variables used are as follows:

Notations:

- I the set of the potential plants;
- J the set of the potential depots;
- K the set of the customers;
- R_i the set of the sizes of a plant $i \in I$;
- S_j the set of the sizes of a depot $j \in J$;
- cp_{ir} the capacity of the plant $i \in I$ with size $r \in R_i$;
- cd_{js} the capacity of the depot $j \in J$ with size $s \in S_j$;
- d_k the demand of the customer $k \in K$;
- fp_{ir} the fixed cost of the plant $i \in I$ with size $r \in R_i$;
- fd_{js} the fixed cost of the depot $j \in J$ with size $s \in S_j$;
- p_{ir} the unit producing cost of the plant $i \in I$ with size $r \in R_i$;
- h_{js} the unit handling cost of the depot $j \in J$ with size $s \in S_j$;
- t_{ij} the unit transportation cost from the plant $i \in I$ to the depot $j \in J$;
- c_{jk} the unit cost of assigning the customer $k \in K$ to the depot $j \in J$;

Decision variables:

- u_{ir} 1, if the plant $i \in I$ with size $r \in R_i$ is opened; 0, otherwise;
- v_{js} 1, if the depot $j \in J$ with size $s \in S_j$ is opened; 0, otherwise;
- x_{irjs} the quantity of product flow from the plant $i \in I$ with size $r \in R_i$ to the depot $j \in J$ with size $s \in S_j$;
- z_{jsk} 1, if the customer $k \in K$ is assigned to the depot $j \in J$ with size $s \in S_j$;

The TECFLP-PDSS can be formulated as follows:

$$\begin{aligned}
 P \quad \min \quad & \sum_{i \in I} \sum_{r \in R_i} f p_{ir} \cdot u_{ir} + \sum_{i \in I} \sum_{r \in R_i} \sum_{j \in J} \sum_{s \in S_j} (p_{ir} + t_{ij}) \cdot x_{irjs} \\
 & + \sum_{j \in J} \sum_{s \in S_j} f d_{js} \cdot v_{js} + \sum_{j \in J} \sum_{s \in S_j} \sum_{k \in K} (h_{js} + c_{jk}) \cdot d_k \cdot z_{jks}
 \end{aligned} \tag{5-1}$$

$$\text{s.t.} \quad \sum_{j \in J} \sum_{s \in S_j} x_{irjs} \leq c p_{ir} \cdot u_{ir} \quad \forall i \in I, r \in R_i \tag{5-2}$$

$$\sum_{r \in R_i} u_{ir} \leq 1 \quad \forall i \in I \tag{5-3}$$

$$\sum_{i \in I} \sum_{r \in R_i} x_{irjs} - \sum_{k \in K} d_k \cdot z_{jks} = 0 \quad \forall j \in J, s \in S_j \tag{5-4}$$

$$\sum_{k \in K} d_k \cdot z_{jks} \leq c d_{js} \cdot v_{js} \quad \forall j \in J, s \in S_j \tag{5-5}$$

$$\sum_{s \in S_j} v_{js} \leq 1 \quad \forall j \in J \tag{5-6}$$

$$\sum_{j \in J} \sum_{s \in S_j} z_{jks} = 1 \quad \forall k \in K \tag{5-7}$$

$$u_{ir} \in \{0, 1\} \quad \forall i \in I, r \in R_i \tag{5-8}$$

$$v_{js} \in \{0, 1\} \quad \forall j \in J, s \in S_j \tag{5-9}$$

$$x_{irjs} \geq 0 \quad \forall i \in I, r \in R_i, j \in J, s \in S_j \tag{5-10}$$

$$z_{jks} \in \{0, 1\} \quad \forall j \in J, s \in S_j, k \in K \tag{5-11}$$

The objective (5-1) minimizes the total costs of opening the plants (the first term), producing the products at the plants and transporting the products from the plants to the depots (the second term), opening the depots (the third term), handling the products at the depots and assigning the customers to the depots (the fourth term). The constraints (5-2) ensure that the total product flows moving out of a plant cannot exceed the capacity of its opened size and are zero if a plant is closed. The constraints (5-3) state that a maximum of one size of a plant can be chosen. The constraints (5-4) are the flow equilibrium constraints at the depots. The constraints (5-5) make sure that the customers' demands assigned to a depot cannot exceed the capacity of its opened size and no customers are assigned to the close depots. The constraints (5-6) state that a maximum of one size of a depot can be chosen. The constraints (5-7) guarantee that each customer is assigned to exactly one depot. The constraints (5-8), (5-9), (5-10) and (5-11) are standard nonnegativity and integrality constraints.

5.3 Lagrangean relaxation approach for the TECFLP-PDSS

As stated in chapter 3 and 4, the Lagrangean relaxation approach is one of the most effective approaches to achieve lower bounds to mixed integer linear programming problems, which relaxes hard

constraints into the objective function by introducing Lagrangean multipliers. The Lagrangean relaxation approach has been widely applied to solve facility location problems, e.g., Geoffrion and McBride (1978) for the CFLP, Klincewicz and Luss (1986) for the CFLPSS and Tragantalerngsak et al. (1997) for the two-echelon, single-source, capacitated facility location problem, etc. Due to the effectiveness of the Lagrangean relaxation approach, thus we use it to obtain good lower and upper bounds of the TECFLP-PDSS.

5.3.1 Lagrangean relaxation model of the TECFLP-PDSS

Similar as the TECFLP-PSS and TECFLP-DSS, various Lagrangean relaxations can be obtained by relaxing different constraints of the TECFLP-PDSS, such as relaxing the constraints (5-4) and (5-7), (5-2) and (5-7) or (5-4) and (5-5). The selection of a suitable relaxation is very important for generating good lower and upper bounds. Based on our preliminary experiments, the constraints (5-2) and (5-7) are relaxed by introducing the non-negative multipliers α_{ir} ($i \in I, r \in R_i$) and the multipliers β_k ($k \in K$) in our implementation of the lagrangean relaxation approach, since it can generate better lower and upper bounds than relaxing the constraints (5-4) and (5-7) or (5-4) and (5-5). The Lagrangean relaxation problem, $LR(\alpha, \beta)$, is therefore as follows:

$$LR(\alpha, \beta) = \min \sum_{i \in I} \sum_{r \in R_i} (fp_{ir} - \alpha_{ir}) \cdot u_{ir} + \sum_{i \in I} \sum_{r \in R_i} \sum_{j \in J} \sum_{s \in S_j} (p_{ir} + t_{ij} + \alpha_{ir}/cp_{ir}) \cdot x_{irjs} \\ + \sum_{j \in J} \sum_{s \in S_j} fd_{js} \cdot v_{js} + \sum_{j \in J} \sum_{s \in S_j} \sum_{k \in K} (h_{js} \cdot d_k - c_{jk} \cdot d_k - \beta_k) \cdot z_{jks} + \sum_{k \in K} \beta_k \quad (5-12)$$

s.t. (3)-(6) and (5-8)-(5-11).

The $LR(\alpha, \beta)$ can be divided into the following two independent subproblems.

The first subproblem, $LR_1(\alpha)$, is

$$LR_1(\alpha) = \min \sum_{i \in I} \sum_{r \in R_i} (fp_{ir} - \alpha_{ir}) \cdot u_{ir} \quad (5-13)$$

s.t. (5-3) and (5-8),

which can be solved exactly in $O(|I| \cdot |R_i|)$ by setting a maximum of one u_{ir} to 1 with the smallest negative $fp_{ir} - \alpha_{ir}$ value for each $i \in I$.

The second subproblem, $LR_2(\alpha, \beta)$, is

$$LR_2(\alpha, \beta) = \min \sum_{i \in I} \sum_{r \in R_i} \sum_{j \in J} \sum_{s \in S_j} (p_{ir} + t_{ij} + \alpha_{ir}/cp_{ir}) \cdot x_{irjs} \\ + \sum_{j \in J} \sum_{s \in S_j} fd_{js} \cdot v_{js} + \sum_{j \in J} \sum_{s \in S_j} \sum_{k \in K} (h_{js} \cdot d_k - c_{jk} \cdot d_k - \beta_k) \cdot z_{jks} \quad (5-14)$$

s.t. (5-4)-(5-6) and (5-9)-(5-11).

In this subproblem, the variables x_{irjs} and z_{jrk} are connected only by the constraints (5-4). There always exists an optimal solution of $LR_2(\alpha, \beta)$ where a depot j with a size s is only supplied by its 'cheapest source'. For any $i \in I$, $j \in J$, $s \in S_j$, set

$$x_{irjs} = \begin{cases} \sum_{k \in K} d_k \cdot z_{jsk}, & \text{if } \{i, r\} = \operatorname{argmin}_{m \in I, n \in R_m} (p_{mn} + t_{mj} + \alpha_{mn}/cp_{mn}), \\ 0, & \text{otherwise.} \end{cases}$$

Then

$$LR_2(\alpha, \beta) = \min \sum_{j \in J} \sum_{s \in S_j} f d_{js} \cdot v_{js} + \sum_{j \in J} \sum_{s \in S_j} \sum_{k \in K} (h_{js} \cdot d_k + w_{js} \cdot d_k - c_{jk} \cdot d_k - \beta_k) \cdot z_{jsk} \quad (5-15)$$

s.t. (5-5), (5-6), (5-9) and (5-11),

where $w_{js} = \min_{m \in I, n \in R_m} (p_{mn} + t_{mj} + \alpha_{mn}/cp_{mn})$. This problem can be further decomposed into $|J|/|S_j|$ independent 0-1 knapsack problems, which can be solved to optimality by using the MINKNAP developed by Pisinger (1995). Then $LR_2(\alpha, \beta)$ is solved by setting a maximum of one v_{js} to 1 with the smallest negative knapsack objective value for each $j \in J$

Let $LB(\alpha, \beta)$ be the sum of the objective value of the solution of $LR_1(\alpha)$ and $LR_2(\alpha, \beta)$, and $\sum_{k \in K} \beta_k$.

Obviously, $LB(\alpha, \beta)$ is a lower bound of the TECFLP-PDSS for giving Lagrangean multipliers (α, β) .

5.3.2 Subgradient optimization for the TECFLP-PDSS

To solve the Lagrangean relaxation $LR(\alpha, \beta)$, a subgradient optimization procedure is adopted to approximately solve the corresponding Lagrangean dual problem.

$$D : \max_{\alpha \geq 0, \beta} LR(\alpha, \beta) \quad (5-16)$$

The subgradient optimization procedure is an iterative process, which solves the Lagrangean relaxation problem and then updates the Lagrange multipliers for the next iteration by using the current subgradient information. The process is terminated if one of the stopping criteria is met.

Let $(\hat{u}^l, \hat{x}^l, \hat{v}^l, \hat{z}^l)$ be the optimal solution of $LR(\alpha^l, \beta^l)$ at iteration l . Denoting $\gamma_{ir}^l = \sum_{j \in J} \sum_{s \in S_j} x_{irjs}^l - cp_{ir} \cdot u_{ir}^l, \forall i \in I, r \in R_i$ and $\eta_k^l = 1 - \sum_{j \in J} \sum_{s \in S_j} z_{jsk}^l, \forall k \in K$, the multipliers for the next iteration $l + 1$ are

updated by

$$\alpha_{ir}^{l+1} = \max\{\alpha_{ir}^l + \theta^l \cdot \gamma_{ir}^l, 0\} \quad (5-17)$$

$$\beta_k^{l+1} = \beta_k^l + \theta^l \cdot \eta_k^l \quad (5-18)$$

where $\theta^l = \lambda \cdot (BUB - LB(\alpha^l, \beta^l)) / (\sum_{i \in I} \sum_{r \in R_i} (\gamma_{ir}^l)^2 + \sum_{k \in K} (\eta_k^l)^2)$ is the step size at iteration l , BUB is the best upper bound of the TECFLP-PDSS found in the previous $l-1$ iterations. $LB(\alpha^l, \beta^l)$ is the lower bound of the TECFLP-PDSS at iteration l . λ is a parameter in the interval $(0, 2]$, which is halved if the best lower bound hasn't been improved for a given number N_{Lag} of consecutive iterations.

Let BLB be the best lower bound found in previous $l-1$ iterations, L_{Lag} be the maximum number of

iterations and ε_{Lag} be a positive small scalar. Then the subgradient optimization procedure is described in detail in Algorithm 5.1.

Algorithm 5.1: Subgradient optimization procedure for the TECFLP-PDSS

Step 1: Initialize ε_{Lag} , L_{Lag} and λ_0 , where λ_0 is a parameter in the interval $(0, 2]$. Set $BUB := +\infty$, $BLB :=$

$$-\infty, \alpha_{ir}^0 := 0, \forall i \in I, r \in R_i, \beta_k^0 := 0, \forall k \in K, \lambda := \lambda_0 \text{ and } l := 1.$$

Step 2: Solve the subproblems $LR_1(\alpha^l)$ and $LR_2(\alpha^l, \beta^l)$ to optimality. Let $LB = LB(\alpha^l, \beta^l)$. If $LB > BLB$, then set $BLB := LB$. If no improvement of BLB is detected in N_{Lag} successive iterations, then set $\lambda := \lambda/2$.

Step 3: Construct a feasible solution of the TECFLP-PDSS based on the Lagrangean relaxation solution (Section 5.3.3). Let UB be the objective value of this solution. If $UB < BUB$, then set $BUB := UB$.

Step 4: If $l > L_{Lag}$ and $\lambda < \varepsilon_{Lag}$, stop. The dual solution corresponding to the BLB is regarded as the optimal dual solution and the solution corresponding to the BUB is regarded as the optimal primal solution.

Step 5: Update α_{ir}^l for $\forall i \in I, r \in R_i$ and β_k^l for $\forall k \in K$ according to the formulas (5-17) and (5-18) respectively.

Step 6: Set $l := l+1$ and return to Step 2.

We observe that as the iterations move on, the value of parameter λ becomes smaller and smaller until the lower bound $LB(\alpha^l, \beta^l)$ becomes stable, and no further improvement of BLB can be achieved. To escape this ‘dilemma’, we restart the subgradient optimization procedure by initializing the BUB and BLB with the best values obtained in the previous subgradient procedure and initializing the Lagrangean multipliers with the multipliers that lead to the BLB . Starting from a relatively good initial point and resetting parameter λ , we hope that the subgradient optimization procedure can increase the probability of obtaining a better lower bound.

5.3.3 Feasible solution construction

Feasible solutions are used in the subgradient optimization procedure to calculate the step size and to get the final solution when the subgradient optimization procedure terminates. A feasible solution of the TECFLP-PDSS is constructed by repairing the Lagrangean relaxation solution at each iteration of the subgradient optimization procedure, i.e., at iteration l . The task of constructing a feasible solution is divided into three stages: 1) open plants and select their sizes, 2) open depots and select their sizes, and determine the customer-depot assignments, 3) determine the product flows from the plants to the depots.

1) Open plants and select their sizes

We first open the plants \bar{i} with the size \bar{r} , where $(\bar{i}, \bar{r}) \in \{(i, r) | \hat{u}_{ir}^l = 1, \forall i \in I, r \in R_i\}$ and denote these opened plants as \bar{I} . If the sum of the capacities of the opened plants can cover all of the customers’

demands, the locations and sizes of the plants are determined. Otherwise, we consider to open more plants and select their sizes, and add these plants into \bar{I} , or we select larger sizes for the currently opened plants.

Define $FP_{ir}^l = fp_{ir}^l - \alpha_{ir}^l$, $i \in I$, $r \in R_i$ as the evaluation cost of opening a plant i with size r at iteration l . Let ΔFP_{ir}^l and ΔCP_{ir}^l be the variations of the evaluation cost and capacity respectively. ΔFP_{ir}^l is calculated as $FP_{ir}^l - FP_{\bar{r}}^l$, if plant i is opened with size \bar{r} , FP_{ir}^l otherwise. ΔCP_{ir}^l is calculated as $cp_{ir} - cp_{\bar{r}}$ if plant i is opened with size \bar{r} , cp_{ir} otherwise. Note we only consider plant sizes that are greater than the currently selected size for an opened plant. The main idea of the proposed construction procedure is to iteratively open a new plant or to change the size of an opened plant until all of the customers' demands are covered. At each iteration, we open a plant i and select its size r with the smallest value of $\Delta FP_{ir}^l / \Delta CP_{ir}^l$. For a previously opened plant, if its size is changed we only preserve the latest one. The detailed procedure for opening plants and selecting their sizes is summarized in Algorithm 5.2.

Algorithm 5.2: Opening plants and selecting their sizes

Step 1: Open all of the plants i with the size r if $u_{ir} = 1$ in the Lagrangean relaxation solution, and denote these plants as set \bar{I} .

Step 2: If the total capacities of the opened plants is equal to or greater than the total quantity of the customers' demands, return the opened plants and their sizes, stop.

Step 3: If the total capacities of the opened plants is less than the total quantity of the customers' demands, repeat Steps 5.3.1-5.3.2 until all of the customers' demands are covered.

Step 3.1: Compute ΔFP_{ir}^l and ΔCP_{ir}^l for each potential plant and possible size.

Step 3.2: Open the plant i and select the size r if it has the smallest $\Delta FP_{ir}^l / \Delta CP_{ir}^l$ value and add it into \bar{I} .

Preserve the size r for the plant i if it has been previously opened.

2) Open depots and select their sizes, and determine the customer-depot assignments

To open depots and select their sizes, and determine the assignments of the customers to these opened depots, we repair the Lagrangean relaxation solution until all of the customers are assigned exactly to one depot. Based on the customer-depot assignments in the Lagrangean relaxation solution, we partition the set K of the customers into three mutually disjointed subsets:

$$K_0 = \{k \in K : \sum_{j \in J} \sum_{s \in S_j} \hat{z}_{jks}^l = 0\},$$

$$K_1 = \{k \in K : \sum_{j \in J} \sum_{s \in S_j} \hat{z}_{jks}^l = 1\} \text{ and}$$

$$K_2 = \{k \in K : \sum_{j \in J} \sum_{s \in S_j} \hat{z}_{jks}^l \geq 1\},$$

such that $K_0 \cup K_1 \cup K_2 = K$. Let $\varphi_{jks} = h_{js} + c_{jk}$ be the cost of assigning a customer k to a depot j with a size s .

5. Two-echelon capacitated facility location problem with plant and depot size selection

First, we open the depot j with the size s if $\hat{u}_{js}^l = 1, \forall j \in J, s \in S_j$ and denote the set of these opened depots as \bar{J} . Second, the customers of the subset K_1 are assigned to the depot j with size s where $\hat{z}_{jsk}^l = 1$. Third, the customers of the subset K_2 are assigned to the depot j with size s where φ_{jsk} is the smallest among all of the depots with $\hat{z}_{jsk}^l = 1$. Fourth, the customers belong to the set K_0 are assigned to the depots one by one based on a regret value. This regret value of a customer k is defined as the difference between the second smallest and the smallest φ_{jsk} values among all of the opened depots whose residual capacities are greater than d_k . If a customer has only one opened candidate depot, then it is given a very high regret value. At each time, the customer with the largest regret value is assigned to the depot j with size s where φ_{jsk} is the smallest. Finally, the opened depots to which no customer has been assigned are closed to save opening cost.

The procedure of opening depots and choosing their sizes, and determining the assignments of the customers is shown in Algorithm 5.3.

Algorithm 5.3: Opening depots and choosing their sizes, and determining the customer-depot assignments

Step 1: Open all of the depots j with s if $\hat{v}_{js}^l = 1$ and denote these opened depots as \bar{J} .

Step 2: Assign the customers in the subset K_1 to the opened depot j with size s where $\hat{z}_{jsk}^l = 1$.

Step 3: Assign the customers in the subset K_2 to the depot j with size s where φ_{jsk} is the smallest and $\hat{z}_{jsk}^l = 1$.

Step 4: Compute the regret values for all of the unassigned customers. Choose the customer with the maximum regret value. Assign the chosen customer to the depot with the smallest φ_{jsk} value, among those depots with sufficient residual capacities. Repeat this Step until all of the customers are assigned or an unassigned customer is failed to be assigned to the opened depots with sufficient residual capacities.

Step 5: Close the depots to which no customer has been assigned and delete them from the set \bar{J} .

3) Determine the product flows from the plants to the depots

If a set of plants \bar{I} with sufficient capacities to satisfy all of the customers' demands are opened by Algorithm 5.2, a set of depots \bar{J} are opened and feasible assignments of all of the customers to these opened depots are determined by Algorithm 5.3, the product flows from the plants to the depots are determined by solving a transportation problem between the plants and the depots. In this transportation problem, the opened plants and depots are viewed as the source nodes and the destination nodes respectively, the plants capacities and the customers' demands assigned to the depots are viewed as the supply capacities and destination demands respectively. After solving the transportation problem to optimality, we close the opened plants whose products are not flowing out to any depot and the depots to which no customers are assigned to save opening cost.

5.4 Hybrid simulated annealing tabu search algorithm for the TECFLP-PDSS

As stated in chapter 3, the TS is a local search based metaheuristic. The TS uses short term memory of recently visited solutions known as tabu list to escape from local optima, but tabu list has a deterministic nature and thus cannot avoid cycling. On the other hand, the simulated annealing (SA), introduced by Kirkpatrick et al. (1983), is an iterative local search metaheuristics. The SA uses a probability function to escape local optima. The stochastic characteristic of the SA avoids cycling but the rate of improvement of solution is very slow, because it has no memory of the recently visited solutions. So it is always possible for the SA search to return to the same solution again. However, with the help of a short-term memory, the search of the SA can be restricted from looping back to previously visited solutions and the performance of the SA can be enhanced significantly. Keeping the above ideas in mind, the hybridization of the SA and TS has been applied in many combinatorial optimization problems in the literature, such as the capacitated clustering problem (Osman and Christofides, 1994), modeling machine loading problem (Swarnkar and Tiwari, 2004) and vehicle routing problem (Küçüköğlü and Öztürk, 2015) etc. To further improve the best solution of the TECFLP-PDSS found in the Lagrangean relaxation approach, we design a hybrid simulated annealing tabu search (HSATS) for the TECFLP-PDSS. The HSATS takes advantages of the stochastic feature of the SA to escape from local optima and the short term memory strategy of the TS to avoid cycling. The proposed HSATS is described in detail in the following.

5.4.1 Move and neighborhood definitions

Similar as the TECFLP-DSS, a solution ζ of the TECFLP-PDSS consists of u , x , v and z . Define $\zeta = (v, z)$ be the set of v and z . In the implementation of the HSATS, we fix the locations of the plants and their sizes as the input feasible solution. Moves are only based on the customer-depot assignments, that is, moves only change ζ . Two kinds of moves are used: *shift* that reassigns one customer from one depot to another, *swap* that interchanges the assignments of two customers that are currently assigned to two different depots. Accordingly, the neighborhoods $N_{shift}(\zeta)$ and $N_{swap}(\zeta)$ are defined as the set of solutions ζ that can be attained from ζ by performing a shift move and a swap move respectively.

5.4.2 Tabu list

A tabu list (TL) is used in the implementation of the HSATS to prevent the recently visited solutions from being revisited. The element (k, j) of the TL records the last iteration number that it will be forbidden to assign the customer k to the depot j . If a customer k assigned to a depot j is reassigned to other depots, the assignment of the customer k to the depot j will be forbidden in the next t iteration. The parameter t is randomly selected from $[T_{min}, T_{max}]$.

5.4.3 Annealing strategy

The annealing schedule determines the value of the transition probability used in the selection criterion and thus plays an important role in the HSATS. In the implementation of the HSATS, an initial temperature T_0 is given and a constant annealing rate μ is used. The temperature T_{i+1} at iteration $i+1$ ($i = 0, 1, \dots$) is calculated as $T_{i+1} = T_i \cdot \mu$. Two kinds of thermal equilibrium iteration numbers, M_t and N_t , are used at each temperature. M_t denote the total iteration number and N_t denote the transition iteration number. Both M_t and N_t are selected in terms of problem characteristics, i.e., M_t is set as $\rho_1 \cdot /K/$ and N_t is set as $\rho_2 \cdot /K/$, where ρ_1 and ρ_2 are positive integer numbers and $/K/$ is the number of the customers. If the temperature is reduced successively L_t iterations without improvement, we increase the current temperature by multiplying it by a parameter η , which is larger than one, expecting to escape from the current local minimum.

5.4.4 The steps of the HSATS

Define $F(\xi)$ as the objective function of ξ and $f(\zeta)$ as the objective function of ζ . In the implementation of the HSATS, we first improve ζ , if a better ζ is found, then the flows x are determined by solving the corresponding transportation problem from the plants to the depots to obtain a new solution ξ' .

The HSATS starts from a high initial temperature T_0 and terminates until the temperature T has reached the final temperature ε_t . The search process consists of a loop of local searches, a step for determining the flows x and a step for dropping temperature. Each of the local search starts from the best solution ζ^* found so far and performs M_t iterations or N_t transition iterations at each temperature. After the local search, if a better local solution ζ' is found, x is determined by solving the corresponding transportation problem and the incumbent solution ξ^* is updated if a better solution ξ' is found. Finally, the current temperature is reduced by multiplying it by μ .

The steps of the HSATS are illustrated in algorithm 5.4, where l_t is the successive iteration number of dropping the temperature without improvement, m_t and n_t are the total iteration and transition iteration numbers at each temperature respectively.

Algorithm 5.4: Steps of the HSATS

Step 1: Set the incumbent solution ξ^* as the best solution ξ found in the Lagrangean relaxation approach and ζ^* as the solution of v and z in the solution ξ^* , initialize T_0 , L_t , μ , η , ε_t , M_t and N_t by setting ρ_1 and ρ_2 , set $l_t := 0$ and $T := T_0$.

Step 2: While $\varepsilon_t > T$, initialize the tabu list TL. If l_t equals to L_t , set $T := T \cdot \eta$ and $l_t := 0$. Set the current solution $\zeta := \zeta^*$, set the local solution $\zeta' := \zeta^*$, $m_t := 0$ and $n_t := 0$, repeat Steps 2.1-2.3.

Step 2.1: While $m_t < M_t$ and $n_t < N_t$, randomly choose a shift or swap move subject to depot capacity

5. Two-echelon capacitated facility location problem with plant and depot size selection

constraints, compute the cost variations Δ of the move and set $m_t := m_t + 1$. If $f(\zeta) + \Delta < f(\zeta')$, or if $\Delta < 0$ and the move does not violate the tabu condition, or if $\sigma < e^{-\Delta/T}$ and the move does not violate the tabu condition, where σ is random parameter selected uniformly from $(0, 1)$, renew the current solution ζ by performing the chosen move, update the TL and set $n_t := n_t + 1$. If $f(\zeta) < f(\zeta')$, set $\zeta' := \zeta$.

Step 2.2: If $f(\zeta') > f(\zeta^*)$, set $l_t := l_t + 1$, otherwise solve the corresponding transportation problem composed of u and ζ' to determine the new flows x' and thus to obtain a new solution ζ' consist of u , x' and ζ' . If $F(\zeta') < F(\zeta^*)$, set $\zeta^* := \zeta'$, $\zeta^* := \zeta'$ and $l_t := 0$, otherwise set $l_t := l_t + 1$.

Step 2.3: Set $T := T \cdot \mu$.

Note that at each temperature, the HSATS starts from the best solution ζ^* found so far and each element (k, j) of the TL is set to -1 . The cost variations Δ incurred by performing a move consists of the variations in the assignment cost and the variations in the depot opening cost. A move is accepted immediately if it satisfies the aspiration condition, i.e., the sum of its Δ and $f(\zeta)$ is less than $f(\zeta')$. A move does not satisfy the aspiration condition is accepted only if it does not violates the tabu condition and Δ is negative or $\sigma < e^{-\Delta/T}$, where σ is random parameter selected uniformly from $(0, 1)$. The tabu condition is based on the transition iteration n_t . When a move is performed and a transition occurs, assuming that a customer k assigned to a depot j is reassigned to other depot in this move, the element (k, j) of the TL is reset to $n_t + t$, which means assigning the customer k to the depot j will be forbidden in the next t transition iteration.

5.5. Computational results

In this study, the proposed Lagrangean relaxation approach and the HSATS are coded in C++. The Numerical experiments are carried out on a personal computer with Intel® Core™ 2 2.33 GHz Quad CPU Q8200 and 2 G RAM under a Microsoft Windows 7 operating system. No instances of the TECFLP-PDSS are publicly available since it is a new problem. Thus in section 5.1, we describe the way to generate random instances. In section 5.2, 50 instances are tested to evaluate the solution quality of the Lagrangean relaxation approach and the HSATS, and the results are compared with those of CPLEX. In addition, 270 instances with different problem parameters, such as the ratios of plant capacity to customer demand, the ratios of depot capacity to customer demand, the numbers of plant size and the numbers of depot size, are tested to show the solution quality and speed of the proposed Lagrangean relaxation approach and the HSATS.

5.5.1 Test instances

Based on the instance generation of the CFLP (Cornuejols et al., 1991) and the TSCFLP (Klose, 1999), the instances are generated in the following way. The coordinates of potential plants, potential depots and customers are randomly selected from a unit square. The unit transportation costs are 10 times the Euclidean

5. Two-echelon capacitated facility location problem with plant and depot size selection

distance between the locations. Let $U[a, b]$ denote a uniform distribution in interval $[a, b]$. The demand d_k of customer $k \in K$ is generated from $U[5, 35]$. Assuming that $cp_{ip} \leq cp_{iq}$ if $p \leq q$, we first generate $cp_{i|R_i|}$ for each plant $i \in I$ from $U[10, 160]$ and then scale the capacities using the ratio $r_{cpd} = \sum_{i \in I} cp_{i|R_i|} / \sum_{k \in K} d_k$. For each $r < |R_i|$, cp_{ir} is set to $r \cdot cp_{i|R_i|} \cdot \sigma / |R_i|$, where σ is a parameter randomly selected from $U[0.9, 1.1]$. As for the capacity cd_{js} for each depot $j \in J$, similarly, we first generate $cd_{j|S_j|}$ from $U[10, 160]$ and then scale the capacities using the ratio $r_{cdd} = \sum_{j \in J} cd_{j|S_j|} / \sum_{k \in K} d_k$. For each $s < |S_j|$, cd_{js} is set to $s \cdot cd_{j|S_j|} \cdot \sigma / |S_j|$. To reflect the plants' and depots' economies of scale, the unit producing cost for a smaller size of a plant is assumed to be larger than that for a bigger size of the same plant and the handling cost for a smaller size of a depot is assumed to be larger than that for a bigger size of the same depot. For each plant $i \in I$ and depot $j \in J$, we first generate the unit producing cost p_{i1} and unit handling cost h_{j1} from $U[5, 7]$ respectively. Then, for any $r > 1$ and $s > 1$, p_{ir} and h_{js} are obtained by multiplying the producing cost $p_{i(r-1)}$ and handling cost $h_{j(s-1)}$ by a random parameter selected from $U[0.9, 0.95]$ respectively. The fixed opening costs for each size of a plant or depot is obtained by multiplying its capacity by a parameter uniformly selected from $U[20, 25]$.

5.5.2 Results

In our implementation of the subgradient optimization procedure, the parameters are set as follows: $L_{Lag} = 3000$, $\varepsilon_{Lag} = 10^{-4}$, $N_{Lag} = 40$ and $\lambda_0 = 1.5$. For the HSATS, parameters T_{min} and T_{max} are set to 15 and 20 respectively, T_0 is set to 200, μ is set to 0.98, L_t is set to 20, ρ_1 is set to 100, i.e., $M_t = 100 \cdot |K|$, ρ_2 is set to 2, i.e., $N_t = 2 \cdot |K|$, η is set to 1.1, ε_t is set to 0.01. The CPLEX version 12.5 with default setting is used as the MIP solver.

Let UB_{Lag} be the *BUB* found by the Lagrangean relaxation approach, UB_H be the *BUB* found by the HSATS, UB_C be the *BUB* found by CPLEX and LB_{Lag} be the *BLB* found by the Lagrangean relaxation approach. The computational results are shown in Tables 5.1-5.5. For each problem set, five instances are generated and tested.

To simplify the presentation of computational results, the column headings to be used are explained as follows:

$ I \times J \times K $	the number of the plants, the depots and the customers respectively
G_{Lag}	the relative gap between UB_{Lag} and LB_{Lag} , i.e., $(UB_{Lag} - LB_{Lag}) / LB_{Lag} \times 100$
G_H	the relative gap between UB_H and LB_{Lag} , i.e., $(UB_H - LB_{Lag}) / LB_{Lag} \times 100$
G_{HC}	the deviation of UB_H from UB_C , i.e., $(UB_H - UB_C) / UB_C \times 100$
T_{Lag}	the CPU time used by the Lagrangean relaxation approach
T_H	the CPU time used by the HSATS
T_{LagH}	the CPU time used by the Lagrangean relaxation approach and the HSATS
T_C	the CPU time of CPLEX

5. Two-echelon capacitated facility location problem with plant and depot size selection

Avg.	the average value of gaps or CPU times for each instance set
Max.	the maximum value of gaps or CPU times for each instance set

In Table 5.1, we compare the results of the Lagrangean relaxation approach and the HSATS using CPLEX in order to evaluate the performances of the Lagrangean relaxation approach and the HSATS. For the instances tested in Table 5.1, $r_{cpd} = 2.0$, $r_{cdd} = 2.0$, $|R_i| = 3$ and $|S_j| = 3$. The experimental results show that CPLEX can find an optimal solution only for the instances of the set 1, and it meets an “out of memory” error for the instances of the other sets. In the implementation, no time limit is imposed on CPLEX, it terminates itself when an optimal solution is found or when the ‘out of memory’ error occurs.

The average gaps between the Lagrangean upper bounds and lower bounds range from 0.74% to 2.00%, and the maximum gap is 2.42%. The average gaps between the HSATS upper bounds and the Lagrangean lower bounds range from 0.51% to 1.75%, and the maximum gap is 2.35%. It is clear that the Lagrangean relaxation approach provides both well upper bounds and good lower bounds for the TECFLP-PDSS and the HSATS also performs well. When comparing with CPLEX, the average gaps between the HSATS upper bounds and those of the CPLEX range from -0.45% to 0.70%. These gaps decrease as the problem size increases. The HSATS can provide better solutions than CPLEX for the larger problems, e.g., the gaps between the HSATS upper bound and those of the CPLEX for the instances of set 10 is -0.45 %. In terms of the computational time, CPLEX takes much more CPU time than the Lagrangean relaxation approach and the HSATS. The Lagrangean relaxation approach and the HSATS only take several to hundreds of seconds of CPU time while the CPLEX takes thousands of seconds. Thus the Lagrangean relaxation approach and the HSATS is much more effective than the CPLEX for solving the TECFLP-PDSS.

Table 5.1: Computational results and comparisons of the HSATS bounds with those of CPLEX

$ I \times J \times K $	$G_{Lag} (%)$		$G_H (%)$		$G_{HC} (%)$		$T_{LagH} (s)$		$T_C (s)$	
	G_{Lag}	Avg.	G_H	Avg.	G_{HC}	Avg.	T_{LagH}	Avg.	T_C	Avg.
5×10×40	2.13		2.09		0.42		19.8		9474.0	
	1.76		1.69		0.74		12.7		41.6	
	2.25	2.00	1.26	1.75	0.58	0.58	12.9	17.0	48.2	1980.8
	1.41		1.36		0.21		21.9		58.5	
	2.42		2.35		0.95		17.7		281.8	
10×20×80	1.42		0.87		0.15		39.5		23164.5	
	2.02		1.86		0.81		36.9		12306.5	
	1.68	1.74	1.36	1.38	0.82	0.40	40.2	40.7	11357.0	12312.4
	1.23		0.86		0.24		33.6		5258.5	
	2.34		1.92		-0.01		53.7		9475.3	
15×30×120	1.62		1.06		0.32		88.1		8263.2	
	2.06		1.84		1.28		73.0		7120.3	
	1.70	1.62	1.53	1.29	1.01	0.70	70.2	71.9	6589.5	6998.2
	1.21		0.79		0.32		63.5		4849.8	
	1.53		1.22		0.57		64.6		8168.2	
20×40×160	1.29		0.85		0.28		128.7		6416.5	
	1.29		0.84		0.21		118.3		5719.6	
	1.38	1.37	1.12	1.00	0.42	0.40	118.3	119.8	4496.3	5052.7
	1.18		0.82		0.20		129.5		5075.1	
	1.72		1.40		0.90		104.3		3556.0	

5. Two-echelon capacitated facility location problem with plant and depot size selection

	0.98		0.65		-0.04		178.1		4874.0	
	1.02		0.62		0.13		233.3		5913.4	
25×50×200	1.09	1.17	0.74	0.85	0.22	0.31	204.5	196.0	5188.1	5429.6
	1.46		1.32		0.71		191.7		5775.6	
	1.32		0.92		0.52		172.5		5397.1	
	1.17		0.78		0.43		262.2		9509.8	
	1.07		0.63		0.27		336.4		7613.8	
30×60×240	1.07	0.99	0.50	0.62	0.01	0.16	251.3	278.8	7551.9	7819.4
	0.69		0.34		-0.18		245.4		6234.1	
	0.96		0.84		0.28		298.8		8187.7	
	0.79		0.56		0.23		444.0		8072.8	
	0.87		0.43		0.09		435.2		6942.3	
35×70×280	1.01	0.88	0.88	0.64	0.41	0.23	433.4	437.4	8406.1	8141.6
	0.80		0.60		0.25		418.6		8241.9	
	0.96		0.74		0.17		455.8		9044.7	
	0.68		0.45		-0.11		582.5		6454.5	
	0.91		0.54		-0.24		677.0		5648.2	
40×80×320	0.72	0.81	0.57	0.57	-0.25	-0.24	569.5	623.7	6405.7	6017.8
	0.75		0.59		-0.50		692.5		5810.5	
	0.98		0.71		-0.13		597.2		5770.2	
	0.74		0.43		-0.53		964.0		5456.9	
	0.63		0.40		-0.40		771.3		7598.2	
45×90×360	0.84	0.78	0.54	0.52	-0.09	-0.31	903.6	905.3	7723.9	7000.9
	0.80		0.62		-0.26		952.3		7249.0	
	0.87		0.60		-0.27		935.1		6976.5	
	0.84		0.56		-0.49		1250.9		5515.3	
	0.67		0.47		-0.43		1276.0		5886.4	
50×100×400	0.77	0.74	0.42	0.51	-0.45	-0.45	1537.9	1314.8	5418.8	5651.6
	0.73		0.62		-0.44		1160.3		5809.1	
	0.70		0.49		-0.42		1349.1		5628.5	
Average	1.21		0.91		0.18					

In Table 5.2, we report the performances of the Lagrangean relaxation approach and the HSATS for the instances with different plant capacities and problem sizes. For all of the instances tested in Table 5.2, $r_{\text{cdd}} = 2.0$, $|R_i| = 3$ and $|S_j| = 3$. The average gaps between the Lagrangean upper bounds and lower bounds range from 0.62% to 1.40% and the maximum gap is 1.68%, the average gaps between the HSATS upper bounds and the Lagrangean lower bounds range from 0.37% to 1.03% and the maximum gap is 1.30%, which indicate that the Lagrangean relaxation approach and the HSATS perform well and they are effective for the instances with different plant capacities. In addition, both the average gaps between the Lagrangean upper bounds and lower bounds, and the average gaps between the HSATS upper bounds and the Lagrangean lower bounds increase as r_{cpd} increases for the instances of the same size, e.g., for the 50×100×400 instances, the average gaps between the Lagrangean upper bounds and lower bounds are 0.62%, 0.72%, 0.82% and 0.95% for $r_{\text{cpd}} = 1.5, 2.0, 2.5$ and 3.0 respectively, and the average gaps between the HSATS upper bounds and the Lagrangean lower bounds are 0.37%, 0.51%, 0.54% and 0.63% for $r_{\text{cpd}} = 1.5, 2.0, 2.5$ and 3.0 respectively. Moreover, the CPU time used by the Lagrangean relaxation approach and the HSATS increases as r_{cpd} increases for the instances of the same size, e.g., for the 50×100×400 instances, the CPU time used by

5. Two-echelon capacitated facility location problem with plant and depot size selection

the Lagrangean relaxation approach and the HSATS is 961.1, 1028.8, 1273.5 and 1587.6 seconds for $r_{cpd} = 1.5, 2.0, 2.5$ and 3.0 respectively. It can be concluded that the Lagrangean relaxation approach and the HSATS are more effective for smaller r_{cpd} than for larger r_{cpd} .

Table 5.2: Computational results for the instances with different plant capacities

$ I \times J \times K $	r_{cpd}	$G_{Lag}(\%)$		$G_H(\%)$		$T_{Lag}(s)$		$T_H(s)$		$T_{LagH}(s)$	
		G_{Lag}	Avg.	G_H	Avg.	T_{Lag}	Avg.	T_H	Avg.	T_{LagH}	Avg.
25×50×200	1.5	0.95		0.73		129.5		37.7		167.3	
		1.29		0.75		109.8		59.0		168.8	
		1.14	1.12	0.70	0.74	136.6	124.8	61.9	57.0	198.5	181.8
		1.28		0.93		124.8		73.3		198.0	
		0.92		0.61		123.3		53.0		176.3	
25×50×200	2.0	1.08		0.75		123.8		64.5		188.3	
		0.87		0.58		147.1		62.4		209.5	
		1.24	1.13	0.54	0.78	127.6	136.2	43.5	60.2	171.1	196.5
		1.59		1.30		146.6		74.8		221.5	
		0.86		0.74		136.0		56.0		191.9	
25×50×200	2.5	1.52		1.06		152.6		89.3		241.9	
		1.47		1.17		165.8		49.0		214.8	
		1.17	1.40	0.75	1.03	152.2	159.3	42.5	54.3	194.6	213.6
		1.54		1.21		144.6		40.8		185.4	
		1.30		0.98		181.4		50.1		231.5	
25×50×200	3.0	1.24		0.97		179.5		51.0		230.6	
		1.05		0.99		231.4		52.3		283.7	
		1.19	1.36	0.94	0.91	169.9	186.8	38.7	51.8	208.6	238.6
		1.65		0.65		175.4		45.7		221.0	
		1.68		1.00		177.8		71.5		249.2	
35×70×280	1.5	1.11		0.71		248.7		98.4		347.0	
		0.75		0.41		300.3		109.8		410.1	
		0.70	0.88	0.46	0.62	288.4	281.4	77.6	86.3	366.1	367.8
		0.99		0.80		301.2		67.6		368.8	
		0.85		0.71		268.6		78.3		346.8	
35×70×280	2.0	1.04		0.50		328.3		109.7		438.0	
		0.99		0.79		291.3		87.8		379.2	
		0.72	0.97	0.56	0.66	315.8	325.2	66.3	87.7	382.1	412.9
		1.09		0.84		356.5		81.8		438.3	
		1.02		0.59		334.2		92.7		426.9	
35×70×280	2.5	0.89		0.66		367.6		74.1		441.7	
		1.12		0.83		358.7		83.1		441.8	
		1.13	1.00	0.68	0.68	445.2	387.7	92.2	78.3	537.3	466.0
		0.96		0.70		379.2		76.5		455.7	
		0.88		0.55		388.0		65.5		453.4	
35×70×280	3.0	1.60		1.10		492.5		58.4		550.9	
		0.98		0.65		613.2		105.2		718.4	
		1.02	1.17	0.73	0.86	494.1	503.5	54.3	82.0	548.5	585.5
		0.87		0.70		482.0		78.9		560.9	
		1.37		1.11		435.8		113.3		549.1	
50×100×400	1.5	0.51		0.31		818.2		147.1		965.3	
		0.75		0.48		832.0		156.2		988.1	
		0.65	0.62	0.34	0.37	761.2	805.3	163.4	155.8	924.5	961.1
		0.57		0.38		739.4		90.8		830.2	

5. Two-echelon capacitated facility location problem with plant and depot size selection

			0.60		0.32		875.6		221.7		1097.3	
			0.79		0.53		921.8		203.0		1124.8	
			0.87		0.68		871.5		134.6		1006.1	
50×100×400	2.0		0.83	0.72	0.52	0.51	851.3	880.2	161.7	148.6	1013.0	1028.8
			0.54		0.38		852.8		103.3		956.1	
			0.54		0.44		903.8		140.3		1044.2	
			1.12		0.79		1181.9		159.2		1341.0	
			0.55		0.33		1144.3		136.6		1280.8	
50×100×400	2.5		0.84	0.82	0.63	0.54	1038.8	1124.7	158.7	148.9	1197.5	1273.5
			0.88		0.50		1146.8		153.9		1300.6	
			0.72		0.44		1111.7		136.0		1247.7	
			0.73		0.48		1401.7		174.9		1576.6	
			1.11		0.62		1501.3		144.7		1646.0	
50×100×400	3.0		1.12	0.95	0.76	0.64	1386.1	1441.1	118.4	146.5	1504.5	1587.6
			0.89		0.76		1403.8		145.3		1549.1	
			0.88		0.57		1512.5		149.1		1661.6	
Average			1.01		0.69							

The performances of the Lagrangean relaxation approach and the HSATS for the instances with different depot capacities and problem sizes are reported in Table 5.3. For all of the instances tested in Table 5.3, $r_{cpd} = 2.0$, $|R_i| = 3$ and $|S_j| = 3$. The average gaps between the Lagrangean upper bounds and lower bounds range from 0.76% to 1.22% and the maximum gap is 1.47%, the gaps between the HSATS upper bounds and the Lagrangean lower bounds range from 0.48% to 0.86% on average and the maximum gap is 1.20%. It is clear that the Lagrangean relaxation approach and the HSATS perform well and they are effective for the instances with different ratio r_{cdd} . It can be seen from Table 5.3 that the ratio r_{cdd} does not have a significant influences on the solution quality and computational time, e.g., for the 50×100×400 instances, the average gaps between the Lagrangean upper bounds and lower bounds are 0.76%, 0.83%, 0.77% and 0.81% for $r_{cdd} = 1.5, 2.0, 2.5$ and 3.0 respectively, the average gaps between the HVNTS upper bounds and the Lagrangean lower bounds are 0.48%, 0.54%, 0.54% and 0.55% for $r_{cdd} = 1.5, 2.0, 2.5$ and 3.0 respectively, and the average CPU time is 1157.2, 1033.0, 1044.7 and 882.6 seconds for $r_{cdd} = 1.5, 2.0, 2.5$ and 3.0 respectively.

Table 5.3: Computational results for the instances with different depot capacities

$ I \times J \times K $	r_{cdd}	$G_{Lag}(\%)$		$G_H(s)$		$T_{Lag}(s)$		$T_H(s)$		$T_{LagH}(s)$	
		G_{Lag}	Avg.	G_H	Avg.	T_{Lag}	Avg.	T_H	Avg.	T_{LagH}	Avg.
25×50×200	1.5	1.19		0.80		141.1		49.5		190.6	
		1.14		0.89		137.6		43.2		180.8	
		1.11	1.16	0.71	0.85	127.7	137.6	53.7	54.1	181.4	191.7
		0.96		0.81		137.3		67.6		204.8	
		1.42		1.06		144.3		56.7		201.0	
25×50×200	2.0	1.42		1.20		123.6		39.0		162.6	
		1.28		0.70		146.4		59.3		205.7	
		1.47	1.22	0.78	0.81	120.5	131.8	33.6	44.2	154.1	176.0
		0.73		0.38		126.0		49.0		175.0	
		1.21		0.97		142.4		40.2		182.5	
		1.41		1.19		117.7		34.8		152.4	
		1.39		0.77		128.7		47.1		175.7	

5. Two-echelon capacitated facility location problem with plant and depot size selection

25×50×200	2.5	0.99	1.16	0.92	0.86	148.0	128.3	37.3	41.8	185.3	170.1
		1.14		0.72		133.2		46.1		179.3	
		0.88		0.69		113.9		43.9		157.8	
25×50×200	3.0	1.22	1.08	1.09	0.75	151.7	122.5	30.7	41.9	182.4	164.4
		0.69		0.55		109.6		39.5		149.0	
		1.30		0.77		121.6		53.3		174.9	
		1.05		0.40		114.7		43.8		158.5	
35×70×280	1.5	1.14	0.89	0.94	0.60	114.8	342.4	42.4	122.2	157.2	464.6
		1.10		0.83		306.2		133.9		440.1	
		0.87		0.54		355.5		123.3		478.7	
		0.97		0.73		371.8		75.3		447.1	
35×70×280	2.0	0.70	0.94	0.47	0.68	344.1	348.6	155.1	80.6	499.2	429.2
		0.79		0.44		334.7		123.3		458.0	
		0.95		0.72		347.6		110.0		457.6	
		0.89		0.67		314.4		57.7		372.1	
35×70×280	2.5	0.95	1.02	0.76	0.66	337.3	323.2	78.3	73.1	415.7	396.3
		1.03		0.61		397.9		97.5		495.4	
		0.87		0.66		345.9		59.3		405.2	
		1.26		0.74		348.7		92.3		441.0	
35×70×280	3.0	0.92	0.98	0.57	0.67	345.9	330.2	61.1	67.3	407.0	397.5
		1.02		0.76		330.0		63.6		393.6	
		0.74		0.50		293.5		71.6		365.1	
		1.15		0.75		298.0		77.0		375.0	
35×70×280	3.0	0.83	0.98	0.51	0.67	269.5	330.2	84.7	67.3	354.2	397.5
		1.12		0.70		298.3		89.5		387.7	
		0.87		0.79		387.4		53.5		440.9	
		0.88		0.60		281.5		53.1		334.6	
50×100×400	1.5	1.18	0.76	0.75	0.48	414.4	975.0	55.8	182.2	470.2	1157.2
		0.94		0.67		1011.0		143.5		1154.6	
		0.88		0.48		913.6		160.0		1073.6	
		0.64		0.45		1049.1		215.7		1264.8	
50×100×400	2.0	0.50	0.83	0.29	0.54	924.5	907.9	163.0	125.1	1087.5	1033.0
		0.85		0.50		976.9		228.6		1205.5	
		0.88		0.54		939.8		143.3		1083.1	
		0.79		0.59		918.8		93.0		1011.8	
50×100×400	2.5	0.68	0.77	0.50	0.54	897.9	947.4	121.8	97.3	1019.7	1044.7
		0.80		0.53		929.4		90.7		1020.0	
		1.01		0.57		853.8		176.7		1030.5	
		0.57		0.48		770.1		82.2		852.3	
50×100×400	2.5	1.01	0.77	0.80	0.54	1033.4	947.4	98.2	97.3	1131.6	1044.7
		0.74		0.46		1104.3		94.3		1198.6	
		0.72		0.41		952.6		107.8		1060.5	
		0.80		0.56		876.5		103.8		980.3	
50×100×400	3.0	0.75	0.81	0.40	0.55	887.3	777.4	126.7	105.2	1014.0	882.6
		0.91		0.70		776.0		93.0		869.1	
		0.87		0.68		828.6		79.7		908.3	
		0.70		0.52		619.8		127.8		747.6	
Average		0.79		0.46		775.3		98.6		873.9	
		0.97		0.67							

5. Two-echelon capacitated facility location problem with plant and depot size selection

In Table 5.4, we provide an analysis of the performances of the Lagrangean relaxation approach and the HSATS for the instances with different numbers of plant size and problem sizes. For all of the instances tested in Table 5.4, $r_{cpd} = 2.0$, $r_{cdd} = 2.0$ and $|S_j| = 3$. The Lagrangean relaxation approach and the HSATS perform well in that the average gaps between the Lagrangean upper bounds and lower bounds range from 0.74% to 1.30% and the maximum gap is 1.54%, the average gaps between the HSATS upper bounds and the Lagrangean lower bounds range from 0.49% to 0.89% and the maximum gap is 1.19%. The number of plant size does not have a significant influence on the solution quality, e.g., for the $50 \times 100 \times 400$ instances, the average gaps between the HSATS upper bounds and the Lagrangean lower bounds are 0.55%, 0.49%, 0.49%, 0.52% and 0.49% for $|R_i| = 2, 3, 4, 5$ and 6 respectively. However, the computational time used by the Lagrangean relaxation approach and the HSATS increases regularly as the number of the plant size increases, e.g., for the $50 \times 100 \times 400$ instances, the average CPU time is 982.9, 1072.1, 1194.9, 1377.0 and 1474.1 seconds for $|R_i| = 2, 3, 4, 5$ and 6 respectively. It is more difficult to solve the instances with more plant sizes than with less plant sizes for the Lagrangean relaxation approach and the HSATS.

Table 5.4: Computational results for the instances with different numbers of plant size

$ I \times J \times K $	$ R_i $	$G_{Lag} (\%)$		$G_H (\%)$		$T_{Lag} (s)$		$T_H (s)$		$T_{LagH} (s)$	
		G_{Lag}	Avg.	G_H	Avg.	T_{Lag}	Avg.	T_H	Avg.	T_{LagH}	Avg.
$25 \times 50 \times 200$	2	1.26		0.60		109.0		37.0		146.0	
		1.35		1.17		112.4		42.4		154.8	
		1.32	1.30	1.07	0.89	110.5	108.2	54.3	44.7	164.9	152.9
		1.54		0.89		101.4		49.0		150.4	
		1.00		0.73		107.6		40.6		148.3	
$25 \times 50 \times 200$	3	1.44		1.19		129.5		49.6		179.1	
		0.84		0.59		143.9		50.1		194.0	
		1.07	1.18	0.66	0.88	137.1	144.1	59.9	51.4	197.0	195.5
		1.13		0.86		154.1		45.4		199.5	
		1.42		1.09		155.8		52.2		207.9	
$25 \times 50 \times 200$	4	0.95		0.71		119.6		42.4		162.1	
		1.16		0.85		164.1		42.1		206.2	
		1.40	1.17	0.94	0.81	163.8	157.4	112.4	59.1	276.1	216.5
		1.02		0.63		158.7		62.6		221.3	
		1.31		0.94		180.8		36.1		216.9	
$25 \times 50 \times 200$	5	1.04		0.62		166.8		37.9		204.7	
		1.09		0.84		164.1		59.6		223.7	
		0.95	0.96	0.71	0.68	189.4	180.1	48.6	46.6	238.0	226.8
		0.81		0.61		190.4		45.9		236.3	
		0.93		0.61		189.9		41.2		231.2	
$25 \times 50 \times 200$	6	1.26		1.02		215.8		42.9		258.7	
		1.20		0.91		206.8		39.0		245.7	
		0.88	1.20	0.77	0.92	210.7	204.6	41.7	41.6	252.3	246.3
		1.23		0.85		218.3		44.4		262.7	
		1.42		1.04		171.7		40.3		212.0	
$35 \times 70 \times 280$	2	0.92		0.61		251.0		110.0		361.0	
		0.94		0.79		280.1		85.8		365.9	
		0.90	0.93	0.67	0.66	318.9	273.8	58.9	82.2	377.8	356.0
		1.20		0.80		268.8		45.8		314.5	
		0.70		0.42		250.2		110.8		361.1	

5. Two-echelon capacitated facility location problem with plant and depot size selection

35×70×280	3		0.78		0.58		367.3		54.5		421.7	436.8
			0.81		0.57		328.0		84.0		412.0	
			0.89	0.89	0.56	0.58	362.1	349.7	110.2	87.1	472.2	
			1.03		0.49		334.5		114.7		449.2	
			0.94		0.71		356.6		72.2		428.8	
35×70×280	4		0.67		0.54		389.8		57.3		447.1	458.6
			0.94		0.51		378.2		84.5		462.7	
			1.13	0.91	0.64	0.59	369.9	382.8	96.0	75.8	465.9	
			1.06		0.72		397.7		69.8		467.5	
			0.73		0.53		378.3		71.6		449.9	
35×70×280	5		0.70		0.57		407.0		55.5		462.5	525.7
			0.99		0.78		411.1		81.7		492.8	
			1.11	0.88	0.83	0.60	456.1	437.8	87.4	87.9	543.5	
			0.71		0.40		459.0		115.6		574.5	
			0.87		0.43		456.0		99.1		555.1	
35×70×280	6		0.69		0.38		486.8		79.6		566.4	575.2
			0.88		0.74		481.6		75.2		556.8	
			1.10	0.93	0.90	0.69	475.1	498.2	91.7	77.0	566.8	
			0.94		0.63		462.9		65.5		528.3	
			1.04		0.79		584.5		73.2		657.7	
50×100×400	2		0.80		0.54		790.2		171.6		961.8	982.9
			0.84		0.57		888.9		172.1		1061.0	
			0.82	0.78	0.65	0.55	899.3	832.1	118.8	150.8	1018.1	
			0.65		0.38		744.5		150.1		894.6	
			0.83		0.62		837.7		141.2		978.9	
50×100×400	3		0.70		0.49		979.9		96.1		1076.0	1072.0
			0.75		0.49		908.1		202.4		1110.4	
			0.60	0.75	0.39	0.49	873.8	898.7	153.7	173.4	1027.5	
			0.85		0.55		877.9		179.6		1057.5	
			0.82		0.52		853.7		235.1		1088.8	
50×100×400	4		0.88		0.47		1078.5		95.9		1174.4	1194.8
			0.79		0.53		972.4		169.8		1142.2	
			0.68	0.78	0.47	0.49	1103.2	1030.2	156.6	164.7	1259.7	
			0.76		0.50		993.0		233.2		1226.2	
			0.82		0.49		1003.7		168.0		1171.7	
50×100×400	5		0.66		0.43		1210.6		188.8		1399.4	1377.0
			0.71		0.61		1171.6		154.9		1326.5	
			0.85	0.74	0.62	0.52	1216.0	1191.0	253.3	186.0	1469.3	
			0.68		0.42		1195.0		157.3		1352.2	
			0.80		0.53		1161.9		175.7		1337.6	
50×100×400	6		0.54		0.30		1247.6		155.9		1403.5	1474.1
			0.89		0.59		1305.3		301.6		1606.9	
			0.62	0.75	0.42	0.49	1314.9	1296.4	148.5	177.7	1463.5	
			0.88		0.52		1256.7		169.5		1426.2	
			0.83		0.61		1357.2		113.0		1470.2	
Average			0.94		0.66							

The performances of the Lagrangean relaxation approach and the HSATS for the instances with different numbers of depot size and problem sizes are reported in Table 5.5. For all of the instances tested in

5. Two-echelon capacitated facility location problem with plant and depot size selection

Table 5.5, $r_{cpd} = 2.0$, $r_{cdd} = 2.0$ and $|S_j| = 3$. The Lagrangean relaxation approach and the HSATS provide good results in that the average gaps between the Lagrangean upper bounds and lower bounds range from 0.72% to 1.23% and the maximum gap is 1.78%, the average gaps between the HSATS upper bounds and the Lagrangean lower bounds range from 0.49% to 0.94% and the maximum gap is 1.28%. Similar as the number of the plant size, the number of depot size does not have a significant influences on the solution quality, e.g., for the $50 \times 100 \times 400$ instances, the average gaps between the HVNTS upper bounds and the Lagrangean lower bounds are 0.49%, 0.50%, 0.49%, 0.57% and 0.49% for $|S_j| = 2, 3, 4, 5$ and 6 respectively. But the computational time used by the Lagrangean relaxation approach and the HSATS increases regularly when the number of depot size increases, e.g., for the $50 \times 100 \times 400$ instances, the average CPU time is 850.6, 996.5, 1295.2, 1337.8 and 1674.9 seconds for $|S_j| = 2, 3, 4, 5$ and 6 respectively. It is also more difficult to solve the instances with more depot size than with less depot size for the Lagrangean relaxation approach and the HSATS.

Table 5.5: Computational results for the instances with different numbers of depot size

$ I \times J \times K $	$ S_j $	$G_{Lag}(\%)$		$G_H(\%)$		$T_{Lag}(s)$		$T_H(s)$		$T_{LagH}(s)$	
		G_{Lag}	Avg.	G_H	Avg.	T_{Lag}	Avg.	T_H	Avg.	T_{LagH}	Avg.
$25 \times 50 \times 200$	2	1.13		0.70		103.4		29.7		133.1	
		0.85		0.65		109.9		46.1		156.0	
		1.43	1.21	1.09	0.94	96.4	103.0	40.2	39.7	136.6	142.8
		1.09		1.00		110.7		31.5		142.2	
		1.52		1.28		94.7		51.2		145.9	
$25 \times 50 \times 200$	3	1.17		0.99		143.6		39.1		182.7	
		1.24		0.86		140.4		57.8		198.2	
		1.10	1.10	0.62	0.72	121.7	128.3	74.1	59.4	195.9	187.7
		0.94		0.46		123.7		77.2		200.9	
		1.03		0.70		112.3		48.6		161.0	
$25 \times 50 \times 200$	4	0.95		0.76		157.7		38.0		195.7	
		0.89		0.60		140.5		46.9		187.3	
		1.78	1.23	1.19	0.82	175.6	164.4	81.4	50.2	257.0	214.6
		1.36		0.72		160.1		38.1		198.2	
		1.15		0.82		188.3		46.8		235.1	
$25 \times 50 \times 200$	5	1.01		0.82		221.3		49.0		270.3	
		1.36		0.72		187.9		54.5		242.3	
		1.41	1.23	1.07	0.85	180.3	192.0	111.9	90.8	292.1	282.8
		1.07		0.74		193.0		193.5		386.5	
		1.29		0.91		177.5		45.4		223.0	
$25 \times 50 \times 200$	6	1.27		1.02		264.7		45.8		310.5	
		1.01		0.83		216.5		44.4		260.9	
		1.10	1.07	0.69	0.73	314.7	253.6	47.4	46.2	362.1	299.7
		0.96		0.46		212.8		36.7		249.5	
		1.03		0.65		259.2		56.6		315.8	
$35 \times 70 \times 280$	2	0.72		0.46		228.5		91.6		320.1	
		0.82		0.51		261.0		53.8		314.8	
		1.05	0.89	0.83	0.58	266.5	248.6	72.1	74.1	338.6	322.7
		0.89		0.49		229.9		69.0		298.9	
		0.97		0.59		257.2		83.9		341.0	

5. Two-echelon capacitated facility location problem with plant and depot size selection

35×70×280	3		0.76		0.59		395.1		92.9		488.0	439.0
			0.98		0.64		331.9		68.1		400.0	
			1.10	0.94	0.64	0.65	327.6	345.5	102.4	93.6	430.0	
			0.88		0.67		351.9		115.8		467.7	
			0.96		0.70		320.8		88.8		409.6	
35×70×280	4		0.94		0.57		439.0		88.4		527.4	493.2
			1.03		0.87		418.9		58.5		477.4	
			0.87	0.88	0.39	0.59	397.8	421.2	91.3	71.9	489.1	
			0.81		0.70		393.5		52.2		445.8	
			0.77		0.43		456.9		69.3		526.2	
35×70×280	5		0.77		0.54		486.0		74.7		560.7	586.3
			0.64		0.50		502.3		63.5		565.7	
			0.65	0.83	0.48	0.63	507.1	509.1	75.3	77.2	582.4	
			0.92		0.77		519.3		78.0		597.3	
			1.19		0.83		530.9		94.4		625.4	
35×70×280	6		0.96		0.79		641.6		60.2		701.8	709.0
			0.69		0.52		617.1		69.5		686.6	
			0.65	0.86	0.42	0.61	599.3	631.6	77.4	77.3	676.7	
			1.04		0.75		626.1		83.8		709.8	
			0.97		0.59		674.0		95.8		769.8	
50×100×400	2		0.96		0.54		888.9		133.0		1021.9	850.6
			0.79		0.50		630.9		145.6		776.5	
			0.60	0.76	0.52	0.49	689.1	712.6	148.8	138.0	837.9	
			0.74		0.39		673.3		143.0		816.3	
			0.69		0.53		681.0		119.4		800.4	
50×100×400	3		0.73		0.45		855.0		119.6		974.6	996.5
			0.68		0.57		845.8		112.8		958.6	
			0.91	0.73	0.56	0.50	844.7	872.8	90.0	123.7	934.7	
			0.65		0.47		861.7		160.4		1022.1	
			0.69		0.44		956.6		135.8		1092.4	
50×100×400	4		0.79		0.50		1092.5		169.3		1261.8	1295.2
			0.72		0.52		1133.9		136.8		1270.7	
			0.66	0.72	0.42	0.49	1194.7	1143.0	172.7	152.2	1367.4	
			0.70		0.54		1154.0		146.2		1300.2	
			0.70		0.46		1139.8		136.0		1275.8	
50×100×400	5		0.87		0.67		1286.2		118.3		1404.5	1337.8
			0.71		0.52		1195.9		82.8		1278.7	
			0.81	0.80	0.63	0.57	1218.3	1222.1	95.0	115.7	1313.3	
			0.93		0.58		1233.8		137.5		1371.3	
			0.67		0.46		1176.2		144.9		1321.1	
50×100×400	6		0.87		0.56		1590.3		141.3		1731.6	1674.8
			0.56		0.36		1553.5		205.6		1759.1	
			0.68	0.76	0.37	0.50	1504.8	1509.0	164.6	165.9	1669.5	
			0.86		0.57		1578.8		175.4		1754.2	
			0.84		0.66		1317.5		142.3		1459.8	
Average			0.93		0.65							

5.6 Conclusions

In this chapter, we deal with the TECFLP-PDSS where each of both plants and depots has several size exhibiting different capacities. The production cost for a larger size of a plant is assumed to be smaller than those of the smaller sizes of the same plant and the unit handling cost for a larger size of a depot is assumed to be smaller than those of the smaller sizes of the same depot to model the economies of scale. This problem allow us to deal with both different sizes for plants and depots, and different production costs at different levels of production at a plant and different handling costs at different levels of handling at a depot. We present a mixed integer programming model for this problem. This model can then simultaneously determine the locations and sizes of the plants, the locations and sizes of the depots, the product flows from the plants to the depots and the assignments of the customers to the depots to satisfy the customers' demands. The TECFLP-PDSS is NP-hard in strong sense. A Lagrangean relaxation approach and a HSATS are proposed for its resolution. First the Lagrangean relaxation approach is used to achieve good lower and upper bounds, and then the HSATS is designed to improve the best upper bound found in the Lagrangean relaxation approach. The numerical experiments on 320 randomly generated instances indicate that the proposed Lagrangean relaxation approach and the HSATS can provide high quality lower bounds and upper bounds to the TECFLP-PDSS. The average gaps are not greater than 1.75%. In addition, instances with different parameters, such as the ratios of plant capacity to customer demand, the ratios of depot capacity to customer demand, the number of the plant size and the number of depot size, are tested to evaluate the robustness of the Lagrangean relaxation approach and the HSATS. The computational results indicate that the proposed Lagrangean relaxation approach and HSATS are effective for the instances with different parameters and can solve the instances that have up to 50 potential plants with 6 possible sizes each, 100 potential depots with 6 possible sizes each and 400 customers in a reasonable time.

This Lagrangean relaxation approach and HSATS perform very well and can provide good lower and upper bounds for our problem. However, some new ideas on solving the problems could be investigated, such as discovering optimality properties by exploring the problem structure. In addition, new features could be added to the problems so that the problems could be more attractive to academia or in practice.

Chapter 6

Conclusions and future researches

The classical two-stage facility location problem focus on determining the locations of plants and depots, and the flows of product from plants to customers via depots with the goal of minimizing the sum of facility opening costs and logistic costs. In these problems, each facility has only one choice of capacity, either uncapacitated or capacitated. The opening cost of a facility is a constant and the unit production or handling cost is the same for all of the plants or depots, thus it can be merged with other linear connection costs. However, in real world there is often need to determine the locations and sizes of facilities in designing a two-stage supply chain network. The size of a facility greatly affects not only its fixed opening cost, but also the unit production or handling cost due to economies of scale. How to make a trade-off between facility location and size is a significant problem in supply chain network design. To deal with this situation, after a systemic review of various facility location models and solution methods used to solve these facility location problems, we studies three types of two-echelon capacitated facility location problem with facility size selection: a two-echelon capacitated facility location problem with plant size selection (TECFLP-PSS), a two-echelon capacitated facility location problem with depot size selection (TECFLP-DSS) and a two-echelon capacitated facility location problem with plant and depot size selection (TECFLP-PDSS) in this thesis. In Chapter 1, we consider the TECFLP-PSS in which each plant has several sizes exhibiting different capacities. In Chapter 2, we investigate the TECFLP-DSS in which each depot has several sizes exhibiting different capacities. In Chapter 3, we concentrate on the TECFLP-PDSS in which each of both plants and depots has several sizes.

These problems extend the previous studied two-stage facility location problems to simultaneously optimizing location and size of facility in a two-stage supply chain network system. How to make a trade-off between the location and size is a key issue in designing supply chain network. This study investigates this problem in the context of two-stage supply chain network system and could help the firms to make a scientific decision in designing two-stage supply chain network system. Thus this research has great significance both in theory and in real-life application. Three mixed integer programming models are formulated and three Lagrangean relaxation approaches are developed to find good lower and upper bound for these three problems respectively. A tabu search (TS), a hybrid variable neighborhood tabu search algorithm (HVNTS) and hybrid simulated annealing tabu search algorithm (HSATS) are designed to further improve the best upper bounds found in the Lagrangean relaxation approaches.

Firstly, we focus our attention on a two-echelon capacitated facility location problem with plant size selection (TECFLP-PSS). This problem allow us to deal with both different sizes for plants and different production costs at different levels of production at a plant. Given a set of potential plants, each of which has several possible sizes exhibiting different capacities, a set of potential capacitated depots and a set of customers with demands, the TECFLP-PSS is to optimally determine the locations of the plants as well as their sizes, the locations of the capacitated depots, the product flows from the plants to the depots and the customer-depot assignment under single sourcing constraints so that all of the customers' demands are satisfied. The objective is to minimize the sum of the fixed opening costs of the plants and depots, the production costs of product and the shipping costs of product from the plants to the depots and then to the

customers. The TECFLP-PSS generalizes the TSCFLP to determine the locations and sizes of the plants, the locations of the depots, the product flows from the plants to the depots and the assignments of the customers to the depots to satisfy the customers' demands. As the TSCFLP is NP-hard in strong sense, the TECFLP-PSS is also NP-hard in strong sense. Due to the NP-hardness of the TECFLP-PSS, we focus on finding good lower and upper bounds for it, especially for the large-sized instances. For this problem, a mixed integer programming model is formulated and a Lagrangean relaxation approach is proposed to achieve lower and upper bounds. To further improved the best upper bound found by the Lagrangean relaxation approach, a tabu search algorithm (TS) is proposed. A total of 245 instances are randomly generated and tested. The computational results demonstrate that all of the instances can be solved in a reasonable time with the average gaps below 1.66%, even for instances that have up to 50 potential plants with 6 possible sizes each, 200 potential depots and 400 customers. Moreover, the performance of the proposed algorithms on the instances with different characteristics, such as the ratios of plant capacity to customer demand, the ratios of depot capacity to customer demand and the number of depot size, are analyzed and the results show that the proposed algorithms are effective for the instances with different parameters.

Secondly, we investigate a two-echelon capacitated facility location problem with depot size selection (TECFLP-DSS). This problem allow us to deal with both different sizes for depots and different handling costs at different levels of handling at a depot. Given a set of potential plants, a set of potential depots, each depot has several possible sizes exhibiting different capacities, and a set of customers with demands. The TECFLP-DSS is to optimally determine the locations of the capacitated plants, the locations and sizes of the depots, the product flows from the plants to the depots and the assignments of the customers to the depots to satisfy the customers' demands. The objective is to minimize the sum of the fixed opening costs of the plants and the depots, the handling costs at the depots, the transportation costs from the plants to the customers and the assignment costs of the customers to the depots. The TECFLP-DSS also generalizes the TSCFLP to determine the locations of the capacitated plants, the locations and sizes of the depots, the product flows from the plants to the depots and the assignments of the customers to the depots to satisfy the customers' demands. The TECFLP-DSS is also NP-hard in strong sense. Due to the NP-hardness of the TECFLP-DSS, we focus on searching for good lower and upper bounds for it, especially for the large-sized instances. For this problem, a mixed integer programming model is developed and a Lagrangean relaxation approach is proposed to achieve good lower and upper bounds. A hybrid variable neighborhood tabu search algorithm (HVNTS) is designed to further improve the best upper bound found by the Lagrangean relaxation approach. The numerical experiments on 245 randomly generated instances indicate that the proposed Lagrangean relaxation approach and the HVNTS can provide high quality lower bounds and upper bounds to the TECFLP-DSS. The average gaps are not greater than 1.16%, with 1.70% at a maximum. In addition, instances with different parameters, such as the ratios of plant capacity to customer demand, the ratios of depot capacity to customer demand and the number of depot size, are tested to evaluate the solution quality and speed of the Lagrangean relaxation approach and the HVNTS. The computational results indicate that the proposed Lagrangean relaxation approach and the HVNTS are effective for the instances with different parameters and can solve the instances that have up to 50 potential plants, 100 depots with 6 possible sizes

each and 400 customers in a reasonable time.

Thirdly, we concentrate a two-echelon capacitated facility location problem with plant and depot size selection (TECFLP-PDSS). This problem allow us to deal with both different sizes for plants and depots, and different production costs at different levels of production at a plant and different handling costs at different levels of handling at a depot. Given a set of potential plants, a set of potential depots, each plant and depot has several possible sizes exhibiting different capacities, and a set of customers with demands, the aim of the TECFLP-PDSS is to select a set of plants and a set of depots to open, select a size for each opened plant and depot, determine the product flows from the plants to the depots and assign the customers to the opened depots to serve the customers at a minimum total cost. This cost includes the fixed opening costs of the facilities, the producing costs at the plants, the handling costs at the depots, the transportation costs from the plants to the depots and the assignment costs of the customers. Like the TECFLP-PSS and TECFLP-DSS, The TECFLP-PDSS also generalizes the TSCFLP to determine the locations and sizes of the plants, the locations and sizes of the depots, the product flows from the plants to the depots and the assignments of the customers to the depots to satisfy the customers' demands. The TECFLP-PDSS is NP-hard in strong sense. Due to the NP-hardness of the TECFLP-PDSS, we also concentrate on achieving good lower and upper bounds for it, especially for the large-sized instances. For this problem, a mixed integer programming model is formulated and a Lagrangean relaxation approach is proposed to achieve efficient lower and upper bounds for it. A hybrid simulated annealing tabu search algorithm (HSATS) is designed to further improve the best upper bound found by the Lagrangean relaxation approach. A total of 320 instances are randomly generated and tested. The computational results demonstrate that all of the instances can be solved in a reasonable time with the average gaps below 1.75 %, even for instances that have up to 50 potential plants with 6 possible sizes each, 100 potential depots with 6 possible sizes each, and 400 customers. In addition, the performance of the proposed algorithms on the instances with different characteristics, such as the ratios of plant capacity to customer demand, the ratios of depot capacity to customer demand, the number of the plant size and the number of depot size, are analyzed and the results show that the proposed algorithms are effective for the instances with different parameters.

There is still much work to be done in future research. In the thesis, we investigate three two-echelon capacitated facility location problem with plant or depot size selection, or both plant and depot size selection. Three mixed integer programming models are formulated for these problems respectively. Lagrangean relaxation approaches are developed for each of the three problems. To further improve the best upper bounds found in the Lagrangean relaxation approaches, a tabu search, a hybrid variable neighborhood tabu search algorithm and a hybrid simulated annealing tabu search algorithm are designed respectively. This algorithms work very well and can provide good lower and upper bounds for our problem. However, some new ideas on solving the problems could be investigated, such as discovering optimality properties by exploring the problem structure, adding valid inequalities to accelerate the solution process, designing improvement strategies for the Lagrangean relaxation approach or the TS, HVNTS and HSATS etc. In addition, new features could be added to the problems so that the problems could be more attractive to academia or in practice.

References

- Aardal, K., 1998a. Capacitated facility location: Separation algorithm and computational experience. *Mathematical Programming* 81, 149-175.
- Aardal, K., 1998b. Reformulation of capacitated facility location problems: How redundant information can help. *Annals of Operations Research*, 82, 289-308.
- Ahuja, R.K., Orlin, J.B., Pallottino, S., Scaparra, M.P., Scutellà, M.G., 2004. A Multi-Exchange Heuristic for the Single-Source Capacitated Facility Location Problem. *Management Science* 50, 749-760.
- Avella, P., Boccia, M., Sforza, A., Vasil'ev, I., 2009. An effective heuristic for large-scale capacitated facility location problems. *Journal Heuristics* 15, 597-615.
- Barahona, F., Anbil, R., 2000. The volume algorithm: producing primal solutions with a subgradient method. *Mathematical Programming* 87, 385-399.
- Barahona, F., Chudak, F.A., 2005. Near-optimal solutions to large scale facility location problems. *Discrete Optimization* 2, 35-50.
- Barceló, J., Casanovas, J., 1984. A heuristic Lagrangian algorithm for the capacitated plant location problem. *European Journal of Operational Research* 15, 212-226.
- Bazaraa, M.S., Sherali, H.D., 1981. On the choice of step size in subgradient optimization. *European Journal of Operational Research* 7, 380-388.
- Beasley, J.E., 1988. An algorithm for solving capacitated warehouse location problems. *European Journal of Operational Research* 33, 314-325.
- Beasley, J.E., 1993. Lagrangean heuristics for location problems. *European Journal of Operational Research* 65, 383-399.
- Belhaiza, S., Hansen, P., Laporte, G., 2014. A hybrid variable neighborhood tabu search heuristic for the vehicle routing problem with multiple time windows. *Computers & Operations Research* 52, 269-281.
- Camerini, P.M., Fratta, L., Maffioli, F., 1975. On improving relaxation methods by modified gradient techniques. *Mathematical Programming Study* 3, 26-34.
- Carrizosa, E., Ushakov A., Vasilyev I., 2012. A computational study of a nonlinear minsum facility location problem. *Computers & Operations Research* 39, 2625-2633.
- Chardaire, P., Lutton, J.L., Sutter, A., 1999. Upper and lower bounds for two-level simple plant location problem. *Annals of Operations Research* 86, 117-140.
- Chen, C.H., Ting, C.J., 2008. Combining Lagrangian heuristic and Ant Colony System to solve the Single Source Capacitated Facility Location Problem. *Transportation Research Part E* 44, 1099-1122.
- Cornuejols, G., Fisher, M.L., Wolsey, L.A., 1977. Location of bank accounts to optimize float: an analytic study of exact and approximate algorithms. *Management Science* 23, 789-810.
- Cornuejols, G., Sridharan, R., Thizy, J.M., 1991. A comparison of heuristics and relaxations for the capacitated plant location problem. *European Journal of Operational Research* 50, 280-297.

References

- Cortinhal, M.J., Captivo, M.E., 2003. Upper and lower bounds for the single source capacitated location problem. *European Journal of Operational Research* 151, 333-351.
- Delmaire, H., Díaz, J., Fernández, E., Ortega, M., 1999. Reactive grasp and tabu search based heuristics for the single source capacitated plant location problem. *Information Systems and Operational Research*, 37, 194-225.
- Díaz, J., Fernández, E., 2002. A branch-and-price algorithm for the single-source capacitated plant location problem. *Journal of the Operational Research Society*, 53, 728-740.
- Domschke, W., Drexl, A., 1985. Add-heuristics starting procedures for capacitated plant location models. *European Journal of Operational Research* 21, 47-53.
- Dupont, L., 2008. Branch and bound algorithm for a facility location problem with concave site dependent costs. *International Journal of Production Economics* 112, 245-254.
- Erlenkotter, D., 1978. A Dual-Based Procedure for Uncapacitated Facility Location. *Operations Research* 26, 992-1009.
- Escobar, J.W., Linfati, R., Baldoquin, M.G., Toth, P., 2014. A Granular Variable Tabu Neighborhood Search for the capacitated location-routing problem. *Transportation Research Part B* 67, 344-356.
- Feldman, E., Lehrer, F.A., Ray, T.L., 1966. Warehouse location under continuous economies of scale. *Management Science* 12, 670-684.
- Fisher, M.L., 1981. The Lagrangian relaxation method for solving integer programming problem. *Management Science* 27, 1-18.
- Filho, V.J.M.F., Galvão, R.D., 1998. A tabu search heuristic for the concentrator location problem. *Computers & Operations Research* 6, 189-209.
- França, P.M., Sosa, N.M., Pureza, V., 1999. An adaptive tabu search approach for solving the capacitated clustering problem. *International Transactions in Operational Research* 6, 665-678.
- Galvão, R.D., Raggi, L.A., 1989. A method for solving to optimality uncapacitated location problem. *Annals of Operations Research* 18, 225-244.
- Gao, L.L., Robinson, E.P., 1992. A dual-based optimization procedure for the two-echelon uncapacitated facility location problem. *Naval Research Logistics* 39, 191-212.
- Gen, M., Tsujimura, Y., Ishizaki, S., 1996. Optimal design of a star-LAN using neural networks. *Computers and Industrial Engineering* 31, 855-859.
- Geoffrion, A.M., 1974. Lagrangian relaxation for integer programming. *Mathematical Programming Study* 2, 82-114.
- Geoffrion, A. M., Graves, G.W., 1974. Multicommodity distribution system design by Benders decomposition. *Management Science*, 20, 822-844.
- Geoffrion, A.M., McBride, R., 1978. Lagrangean relaxation applied to capacitated facility location problems. *IIE Transactions* 10, 40-7.
- Ghosh, D., 2003. Neighborhood search heuristics for the uncapacitated facility location problem. *European Journal of Operational Research* 150, 150-162.
- Glover, F., 1986. Future paths for integer programming and links to artificial intelligence. *Computers &*

- Operations Research 13, 533-549.
- Glover, F., 1989. Tabu search-Part I. ORSA Journal on Computing 1, 190-206.
- Glover, F., 1990. Tabu search-Part II. ORSA Journal on Computing 2, 4-32.
- Grolimund, S., Ganascia, J.G., 1997. Driving tabu search with case-based reasoning. European Journal of Operational Research 103, 326-338.
- Hansen, P., Mladenović, N., 2001. Variable Neighborhood Search: Principles and Applications. European Journal of Operational Research 130, 449-467.
- Harkness, J., ReVelle, C., 2003. Facility location with increasing production costs. European Journal of Operational Research 145, 1-13.
- Harris I., Mumford C.L., Naim M.M., 2014. A hybrid multi-objective approach to capacitated facility location with flexible store allocation for green logistics modeling. Transportation Research Part E 66, 1-22.
- Held, M., Wolfe, P., Crowder, H.P., 1974). Validation of subgradient optimization. Mathematical Programming 6, 62-88.
- Hindi, K.S., Basta, T., 1994. Computationally efficient solution of a multiproduct, two-stage distribution-location problem. The Journal of the Operational Research Society 45, 1316-1323.
- Hindi, K., Pienkosz, K., 1999. Efficient solution of large scale, single-source, capacitated plant location problem. Journal of the Operational Research Society 50, 268-274.
- Hinojosa, Y., Puerto, J., Fernandez, F.R., 2000. A multiperiod two-echelon multicommodity capacitated plant location problem. European Journal of Operational Research 123, 271-291.
- Holmberg, K., Ling, J., 1997. A Lagrangean heuristic for the facility location problem with staircase costs. European Journal of Operational Research 97, 63-74.
- Holmberg, K., Rönnqvist, M., Yuan, D., 1999. An exact algorithm for the capacitated facility location problems with single sourcing. European Journal of Operational Research 113, 544-559.
- Jacobsen, S.K., 1983. Heuristics for the capacitated plant location model. European Journal of Operational Research 12, 253-261.
- Kirkpatrick, S.C., Gelatt, C.D., Vecchi, M.P., 1983. Optimization by simulated annealing. Science 220, 671-680.
- Klincewicz, J.G., Luss, H., 1986. A Lagrangian Relaxation Heuristic for Capacitated Facility Location with Single-Source Constraints. The Journal of the Operational Research Society 37, 495-500.
- Klose, A., 1999. An LP-Based Heuristic for Two-Stage Capacitated Facility Location Problems. The Journal of the Operational Research Society 50, 157-166.
- Klose, A., 2000. A Lagrangean relax-and-cut approach for the two-stage capacitated facility location problem. European Journal of Operational Research 126, 408-421.
- Klose, A., Drexl, A., 2005. Facility location models for distribution system design. European Journal of Operational Research 16, 24-29.
- Klose, A., Görtz, S., 2007. A branch-and-price algorithm for the capacitated facility location problem. European Journal of Operational Research 179, 1109-1125.

References

- Körkel, M., 1989. On the exact solution of large-scale simple plant location problems. *European Journal of Operational Research* 39, 157-73.
- Krarup, J., Pruzan, P.M., 1983. The simple plant location problem: survey and synthesis. *European Journal of Operational Research* 12, 36-81.
- Küçüköglu İ., Öztürk N., 2015. An advanced hybrid meta-heuristic algorithm for the vehicle routing problem with backhauls and time windows. *Computers & Industrial Engineering* 86, 60-68.
- Kuehn A.A., Hamburger M.J., 1963. A heuristic program for locating warehouses. *Management Science* 9, 643-66.
- Lee, C.Y., 1993. A cross decomposition algorithm for a multiproduct-multitype facility location problem. *Computers & Operations Research* 20, 527-540.
- Leung, J.M.Y., Magnanti, T.L., 1989. Valid inequalities and facets of the capacitated plant location problem. *Math. Program.* 44, 271-29.
- Marín, A., Pelegrín, B. (1999). Applying Lagrangian relaxation to the resolution of two-stage location problems. *Annals of Operations Research* 86, 179-198.
- Mazzola, J.B., Neebe, A.W., 1999. Lagrangian-relaxation-based solution procedures for a multiproduct capacitated facility location problem with choice of facility size. *European Journal of Operational Research* 115, 285-299.
- Melo, M.T., Nickel, S., Saldanha-da-Gama, F., 2009. Facility location and supply chain management-A review. *European Journal of Operational Research* 196, 401-412.
- Mladenović, N., Hansen, P., 1997. Variable Neighborhood Search. *Computers & Operations Research* 24, 1097-1100.
- Nemhauser G.L., Wolsey L.A., Fisher L.M., 1978. An analysis of approximations for maximizing submodular set functions. *Mathematical Programming* 14, 265-94.
- Nozick, L.K., 2001. The fixed charge facility location problem with coverage restrictions. *Transportation Research Part E* 37, 281-296.
- Osman I.H., Christofides N., 1994. Capacitated Clustering Problems by Hybrid Simulated Annealing and Tabu Search. *International Transactions in Operational Research* 1, 317-336.
- Pirkul, H., 1987. Efficient algorithms for the capacitated concentrator problem. *Computers & Operations Research* 14, 197-208.
- Pirkul, H., Jayaraman, V., 1998. A multi-commodity, multi-plant, capacitated facility location problem: formulation and efficient heuristic solution. *Computers and Operations Research*, 25, 869-878.
- Pisinger, D., 1995. An expanding-core algorithm for the exact 0-1 knapsack problem. *European Journal of Operational Research* 87, 175-87.
- ReVelle, C.S., Eiselt, H.A., Daskin, M.S., 2008. A bibliography for some fundamental problem categories in discrete location science. *European Journal of Operational Research* 184, 817-848.
- Ro, H., Tcha, D., 1984. A branch and bound algorithm for the two-level uncapacitated facility location problem with some side constraints. *European Journal of Operational Research* 18, 349-358.
- Rönnqvist, M., Tragantalerngsak, S., Holt, J. 1999. A repeated matching heuristic for the single-source

-
- capacitated facility location problem. *European Journal of Operational Research*, 116, 51-68.
- Soland, R.M., 1974. Optimal Facility Location with Concave Costs. *Operations Research* 22, 373-382.
- Sridharan, R., 1993. A Lagrangian heuristic for the capacitated plant location problem with single source constraints. *European Journal of Operational Research* 66, 305-312.
- Sun, M.H., 2012. A tabu search heuristic procedure for the capacitated facility location problem. *Journal of Heuristics* 18, 91-118.
- Swarnkar, R., Tiwari, M.K., 2004. Modeling machine loading problem of FMSs and its solution methodology using a hybrid tabu search and simulated annealing-based heuristic approach. *Robotics and Computer-Integrated Manufacturing* 20, 199-209.
- Taniguchi, E., Noritake, M., Yamada, T., Izumitani, T., 1999. Optimal size and location planning of public logistics terminals *Transportation Research Part E* 35, 207-222.
- Tragantalerngsak, S., Holt, J., Rönnqvist, M., 1997. Lagrangean heuristics for the two-echelon, single-source, capacitated facility location problem. *European Journal of Operational Research* 102, 611-625.
- Tragantalerngsak, S., Holt, J., Rönnqvist, M., 2000. An exact method for the two-echelon, single-source, capacitated facility location problem. *European Journal of Operational Research* 123, 473-489.
- Tuzun, D., Burke, L.I., 1999. A two-phase tabu search approach to the location routing problem. *European Journal of Operational Research* 116, 87-99.
- Vaithyanathan, S., Burke, L.I., Magent, M.A., 1996. Massively parallel analog tabu search using neural networks applied to simple plant location problems. *European Journal of Operational Research* 93, 317-330.
- Van Roy, T.J., 1986. A cross decomposition algorithm for capacitated facility location. *Operations Research* 34, 145-163.
- Wentges, P., 1996. Accelerating Benders' decomposition for the capacitated facility location problem. *Mathematical Methods of Operations Research* 44, 267-90.
- Wu, L.Y., Zhang, X.S., Zhang, J.L., 2006. Capacitated facility location problem with general setup cost. *Computers & Operations Research* 33, 1226-1241.
- Yang, Z., Chu, F., Chen, H.X., 2012. A cut-and-solve based algorithm for the single-source capacitated facility location problem. *European Journal of Operational Research* 221, 521-532.

Titre: Modèles et algorithmes pour les problèmes de localisation de sites à deux échelons avec la sélection de taille

Mots clés: localisation de sites; choix de taille de sites; relaxation lagrangienne; recherche tabou; méthode hybride de recherche tabou et à voisinage variable; méthode hybride du recuit simulé et de la recherche tabou;

Résumé La localisation de sites est des décisions stratégiques les plus importantes pour les entreprises dans le contexte de la mondialisation d'aujourd'hui. Les travaux existant dans la littérature traitant ce type de problèmes se concentrent principalement sur la détermination de l'emplacement des sites et des flux de produits provenant les sites localisés aux clients dans le but de minimiser le coût total de construction, de production et logistiques. Cependant, il est très important de bien choisir simultanément la capacité et la localisation des sites parce que la taille des sites a une grande influence sur ces coûts sur le long terme. La détermination de la location et de capacité des sites reste encore un problème ouvert.

Dans cette thèse, nous étudions trois nouvelles variantes de problèmes de location de sites à deux échelons avec la sélection de taille (TECFLP). Les deux premières parties concentrent sur les TECFLPs avec sélection sé-

parée de taille d'usines ou de dépôts. La Troisième partie étudie le TECFLP avec sélection simultanée des tailles d'usines et de dépôts. Pour ces problèmes, trois modèles de programmation linéaire mixte sont proposés. Ensuite les approches basées sur la relaxation lagrangienne selon les caractéristiques de chaque problème sont développés. Pour améliorer les meilleures solutions proposées par les approches de relaxation lagrangienne, une méthode de recherche tabou, une méthode hybride de recherche tabou et à voisinage variable, une méthode hybride du recuit simulé et de la recherche tabou sont respectivement adaptés pour ces trois problèmes. Les algorithmes développés sont testés et évalués à travers 810 instances générées aléatoirement. Les résultats numériques montrent que nos méthodes sont capables de fournir des solutions de qualité avec un temps de calcul raisonnable.



Title: Models and algorithms for two-echelon capacitated facility location problem with facility size selection

Keywords: Facility location, Facility size, Lagrangean relaxation, Tabu search, Hybrid variable neighborhood tabu search, Hybrid simulated annealing tabu search;

Abstract : Facility location is one of the most important strategic decisions for firms in globalization. Previous works on facility location in the literature mainly focus on determining the locations of facilities and the flows of products from facilities to customers with the goal of minimizing the sum of facility opening costs, production and logistic costs. However, it's very important to determine at the same time the appropriate sizes for these facilities because they greatly affects these costs on the long term. Determining facility location and size is always an open problem.

In this thesis, we study three new two-echelon capacitated facility location problems (TECFLP) with facility size selection. The two first parts of the work focus on two-echelon facility location problems with plant and depot

size selection, respectively. The third part concentrates on TECFLP considering simultaneously plant and depot size selection. For these problems, three corresponding mixed integer programming models are formulated and then Lagrangean relaxation approaches according to the problems' characteristics are developed. To further improve the best solutions obtained by the Lagrangean Relaxation approaches, a tabu search, a hybrid variable neighborhood tabu search and a hybrid simulated annealing tabu search are adapted for the three problems respectively. The developed algorithms are tested and evaluated through 810 randomly generated instances. Computational results show our algorithms can provide high quality solutions within a reasonable computation time.

