



HAL
open science

Cubical categories for homotopy and rewriting

Maxime Lucas

► **To cite this version:**

Maxime Lucas. Cubical categories for homotopy and rewriting. Algebraic Topology [math.AT]. Université Paris 7, Sorbonne Paris Cité, 2017. English. NNT: . tel-01668359

HAL Id: tel-01668359

<https://hal.science/tel-01668359>

Submitted on 20 Dec 2017

HAL is a multi-disciplinary open access archive for the deposit and dissemination of scientific research documents, whether they are published or not. The documents may come from teaching and research institutions in France or abroad, or from public or private research centers.

L'archive ouverte pluridisciplinaire **HAL**, est destinée au dépôt et à la diffusion de documents scientifiques de niveau recherche, publiés ou non, émanant des établissements d'enseignement et de recherche français ou étrangers, des laboratoires publics ou privés.

ÉCOLE DOCTORALE 386 — SCIENCES MATHÉMATIQUES DE PARIS CENTRE

CUBICAL CATEGORIES FOR HOMOTOPY AND REWRITING

Thèse de doctorat de l'Université Sorbonne Paris Cité
Préparée à l'Université Paris Diderot.

par

Maxime LUCAS

Thèse soutenue publiquement devant le jury constitué de

Clemens BERGER
Thierry COQUAND
Pierre Louis CURIEN
Marcelo FIORE
Yves GUIRAUD
Georges MALTSINIOTIS
Simona PAOLI
Richard STEINER

Rapporteur
Examineur
Directeur de thèse
Rapporteur
Directeur de thèse
Examineur
Examineur
Examineur

Contents

Contents	1
1 Introduction	3
1.1 The word problem	4
1.1.1 The undecidability of the word problem	4
1.1.2 Rewriting	5
1.1.3 Squier's theorems	6
1.2 Higher-dimensional rewriting	8
1.2.1 Squier's theory and coherence theorems	8
1.2.2 Resolutions of monoids and categorification	9
1.3 Coherence through higher-dimensional rewriting	11
1.3.1 Rewriting and polygraphs	11
1.3.2 The 2-Squier condition of depth 2	12
1.3.3 Sketch of the proof of Theorem 3.1.3.5	13
1.3.4 Conclusion of Chapter 3	15
1.4 Cubical ω -categories for rewriting	17
1.4.1 Cubical categories and their relationship with other structures	17
1.4.2 Invertibility in cubical categories	19
1.4.3 Permutations and cubical (ω, p) -categories	21
1.5 Higher-dimensional rewriting in cubical categories	23
1.5.1 Model structure and the Gray tensor product	23
1.5.2 The two versions of Squier's theorem	24
1.5.3 Higher-dimensional rewriting in Gray monoids	25
2 Classical higher dimensional rewriting	27
2.1 Globular (n, p) -categories and polygraphs	28
2.1.1 Globular categories	28
2.1.2 Polygraphs	31
2.2 Higher-dimensional rewriting	33
2.2.1 Termination	33
2.2.2 Branchings and Confluence	33
2.2.3 Coherence	35
2.3 Application to the coherence of bicategories and pseudofunctors	36
2.3.1 Coherence for bicategories	36
2.3.2 Coherence for pseudofunctors	40
3 Coherence for pseudonatural transformations	45
3.1 Proof of the coherence for pseudonatural transformations	46
3.1.1 The structure of pseudonatural transformation	46

3.1.2	A convergent sub-polygraph of $\mathbf{PNTrans}[f, g]$	51
3.1.3	The 2-Squier condition of depth 2 and $\mathbf{PNTrans}[f, g]$	53
3.1.4	Adjunction of the units 2-cells	58
3.1.5	Adjunction of the units 3-cells	59
3.2	Partial coherence and transformation of polygraphs	65
3.2.1	White categories and white polygraphs	65
3.2.2	Partial coherence in pointed white $(4, 3)$ -categories	69
3.2.3	Injective functors between white categories	71
3.3	Transformation of a $(4, 2)$ -polygraph into a white $(4, 3)$ -polygraph	78
3.3.1	Weakening of the exchange law	79
3.3.2	Weakening of the invertibility of 3-cells	82
3.3.3	Adjunction of formal inverses to 2-cells	83
3.3.4	Adjunction of connections between 2-cells	84
3.3.5	Reversing the presentation of a white $(4, 3)$ -category	88
3.4	Proof of Theorem 3.1.3.5	93
3.4.1	Local coherence	93
3.4.2	Orderings on the cells of \mathcal{F}^w	95
3.4.3	Partial coherence of $\mathcal{F}^{w(3)}$	98
4	Cubical (ω, p)-categories	103
4.1	Cubical categories	104
4.1.1	Cubical sets	104
4.1.2	Cubical ω -categories	106
4.1.3	Equivalence between cubical and globular ω -categories	109
4.2	Invertible cells in cubical ω -categories	111
4.2.1	R_i -invertibility	111
4.2.2	Plain invertibility	115
4.2.3	T_i -invertibility	116
4.3	Relationship of cubical (ω, p) -categories with other structures	120
4.3.1	Cubical and globular (ω, p) -categories	120
4.3.2	Augmented directed complexes and (ω, p) -categories	121
4.4	Permutations in cubical (ω, p) -categories	127
4.4.1	Cubical $(\omega, 1)$ -categories are symmetric	127
4.4.2	Transfers between cubical ω -categories	133
5	Resolution of monoids	139
5.1	Resolutions of monoids by Gray polygraphs	140
5.1.1	Gray polygraphs	140
5.1.2	Free Gray $(\omega, 1)$ -monoids are free $(\omega, 1)$ -categories	146
5.1.3	The simplicial monoid of local branchings	150
5.2	Proof of Theorem 5.1.3.8	152
5.2.1	Generalised connections	152
5.2.2	Generalised composition	155
5.2.3	Construction of the normalisation strategy	158
5.3	Construction of polygraphic resolutions and examples	164
5.3.1	Critical branchings	164
5.3.2	The reduced standard resolution of a monoid	169
5.3.3	Squier's resolution of a monoid	176
	Bibliography	179

Chapter 1

Introduction

1.1 The word problem

1.1.1 The undecidability of the word problem

Although algorithms are nowadays commonly associated with computer science, they appeared together with mathematics as early as 1600 B.C. in Babylonia. Famous algorithms include Euclid's algorithm for computing the greatest common divisor, the sieve of Eratosthenes for finding prime numbers, Newton's method to approximate the roots of a real-valued function, and Lovelace's program for computing Bernoulli numbers. The word algorithm itself comes from the latinized version of al-Khwarizmi's name, a IXth century Persian scholar. At the beginning of the XXth century, Hilbert's 10th problem called for an algorithm capable of determining whether a Diophantine equation had integer solutions.

However, it wasn't before 1936 and the works of Church [19] [20] and Turing [84] [85] on the *Entscheidungsproblem* (following the pioneering work of Godel [32]) that the first problem provably unsolvable by algorithmic means arose. Such a problem is called undecidable. The *Entscheidungsproblem* (literally, the 'decision problem') was a problem raised in 1928 by Hilbert and Ackermann [1]. It asked for an algorithm capable of deciding whether a first-order formula is valid or not. Soon after, Post introduced the notion of reducibility [68], allowing to prove the undecidability of many other problems. In particular, he proved in 1947 the undecidability of the word problem for monoids [69] (a result also independently proved by Markov [63]), a question opened by Thue in 1914 [82] and which is of central importance to this work.

Recall that a monoid M is the data of a set M equipped with a binary associative and unary operation $M \times M \rightarrow M$. If E is a set then the free monoid generated by E is the set of all finite (possibly empty) sequences of elements in E , where the product is given by concatenation. Not all monoids are free though. In general, they can be described using a *presentation*. A presentation is the data of a set E of generators together with a set R of generating relations between the elements of E^* . The monoid presented by such an object is the quotient of E^* by the congruence generated by R . For example, the monoid B_3^+ , called the *monoid of positive braids on three strands*, can be described by the following presentation:

$$B_3^+ = \langle s, t \mid sts = tst \rangle. \quad (1.1.1)$$

In B_3^+ , the generating relation $sts = tst$ induces for instance the relations $stst = tstt$ and $stss = ssts$ (where in the second example we apply the generating relation twice). Note that a monoid may also have more than one presentation. For example, another presentation of B_3^+ is given by:

$$B_3^+ = \langle s, t, a \mid ta = as, st = a, sas = aa, saa = aat \rangle. \quad (1.1.2)$$

Given a presentation (E, R) of a monoid M , the quotient of E^* by the generating relations induces a surjective morphism of monoids $\pi : E^* \rightarrow M$. The word problem for monoids is the following:

Problem 1.1.1.1 (Thue, [82]). *Given a monoid M , does there exist a presentation (E, R) of M such that there exists an algorithm deciding, for all $u, v \in E^*$, whether $\pi(u) = \pi(v)$?¹*

Although the negative results of Post and Markov prove that there exist monoids for which such an algorithm doesn't exist, there are techniques to solve the word problem for some well-behaved monoids. The technique we are particularly interested in is based on rewriting theory.

¹Any reader not convinced of the utility of such an algorithm should prove whether the words $stsstststst$ and $tstststststs$ are equal in B_3^+ .

1.1.2 Rewriting

Rewriting techniques became widespread in the 1930s in multiple contexts. It is therefore not surprising that the first paper studying rewriting theory in itself was published in 1941 by Newman. At the time, the two main applications of rewriting were to provide solutions to the word problem (both in the case of monoids and of other structures), and in Church’s λ -calculus [19], where the β -reduction forms a rewriting rule. We cannot resist quoting the description of rewriting theory given by Newman in [67]:

The name “combinatorial theory” is often given to branches of mathematics in which the central concept is an equivalence relation defined by means of certain “allowed transformations” or “moves”. A class of objects is given, and it is declared of certain pairs of them that one is obtained from the other by a “move”; and two objects are regarded as equivalent if, and only if, one is obtainable from the other by a series of moves. [...] In many of such theories the moves fall naturally into two classes, which may be called “positive” and “negative”. Thus in a free group the cancelling of a pair of letters may be called a positive move, the insertion negative; in topology the breaking of an edge, in [λ -calculus] the application of [β -reduction], may be taken as positive moves.

The idea behind rewriting theory is that, given a presentation (E, R) , it is useful to consider the *order relation* generated by R in order to study the *equivalence relation* that it generates. To do that, we need a bit more structure on a presentation: we need a distinguished orientation of each generating relation. Let us define a string rewriting system (or word rewriting system) as a set E of generators and a set R of generating relations, together with source and target maps $s, t : R \rightarrow E^*$. Of course, by forgetting about the orientation, one can see any string rewriting system as a presentation. For example, the following string rewriting system is a presentation of B_3^+ :

$$B_3^+ = \langle s, t, a \mid \alpha : ta \Rightarrow as, \beta : st \Rightarrow a, \gamma : sas \Rightarrow aa, \delta : saa \Rightarrow aat \rangle.$$

Starting from an element f of R , an element of the form ufv , such as $a\beta t : astt \Rightarrow aat$ is called a *rewriting step*. A sequence of rewriting steps, each one rewriting the previous one’s target, is called a *rewriting path*. Finally, a sequence consisting of both rewriting steps and inverse rewriting steps is called an *equivalence path*. In order to provide a solution to the word problem for B_3^+ , let us showcase two properties of the string rewriting system presenting B_3^+ . One, it is a *terminating* presentation, which means that there exists no infinite sequence of rewriting steps:

$$u_0 \xrightarrow{f_1} u_1 \xrightarrow{f_2} u_2 \xrightarrow{f_3} u_3 \dots$$

Second, it is *confluent*. Define a branching to be a pair (f, g) of rewriting sequences with the same source. Confluence holds if, for any branching, there exist rewriting sequences f' and g' of same target, such that f' rewrites the target of f and g' rewrites the target of g . For instance in the case of B_3^+ , the rewriting steps $\gamma as : sasas \Rightarrow aaas$ and $sa\gamma : sasas \Rightarrow saaa$ form a branching, leading to the following so-called *confluence diagram*:

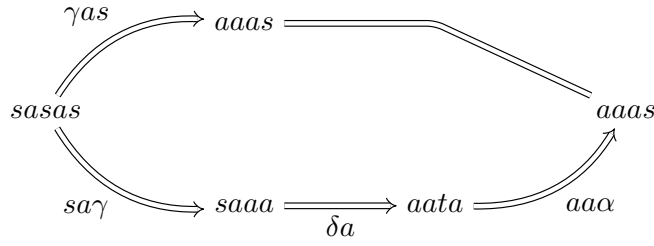

Note that although confluence may be difficult to verify, there exist results relating it to more elementary properties. General references for rewriting theory are [4], and [10] for the particular case of string rewriting. In particular, Newman’s lemma [67] shows that for a terminating word rewriting system to be confluent, it is enough to show the confluence of the *local branchings*, that is the branchings (f, g) where both f and g are rewriting steps. The critical pairs lemma (see for example [10]) further restricts the set of branchings that one needs to check in order to obtain confluence to the so-called *critical pairs*, which are in finite number whenever E and R are. Finally, in the case where one has a terminating string rewriting system, Knuth-Bendix completion [53] may be used to ensure the confluence.

A word rewriting system that is both terminating and confluent is called *convergent*. The point of convergent string rewriting systems is that any monoid which can be presented by a finite convergent word rewriting system has a decidable word problem, using the so-called *normal form procedure*. This led Jansen to the following problem:

Problem 1.1.2.1 (Jansen, [46] [47]). *Does there exist a monoid whose word problem is decidable, but which does not admit a presentation by a finite convergent string rewriting system?*

In 1985, Kapur and Narendran [50] studied the case of B_3^+ . They showed that even if, as we saw, the monoid B_3^+ admits a finite convergent presentation, it admits no such presentation on the set of generators $\{s, t\}$. This means in particular that, if one was to show that a monoid does not admit a finite convergent presentation, one would have to check every possible set of generators. As a consequence, new methods had to be introduced to answer Jansen’s question.

1.1.3 Squier’s theorems

In 1987, Squier introduced in [74] a homological invariant on monoids. By invariant we mean that, although this invariant is defined on presentations, it actually only depends on the presented monoid. Squier proved in particular that all monoids presented by a finite convergent string rewriting system satisfy a homological finiteness condition. Moreover, he was able to produce a monoid whose word problem is decidable, but which does not satisfy this finiteness condition. By Squier’s homological theorem, this monoid cannot admit a presentation by a finite convergent string rewriting system, answering by the negative to Jansen’s problem.

In a posthumous paper published in 1994 [75], Squier introduced a homotopical version of his finiteness condition. To do that, he showed how to extend a convergent string rewriting system (E, R) presenting a monoid M , into a *coherent presentation* (E, R, S) of M . Let us explicit the structures at hand. First, E is a set, and it generates a free monoid E^* . Then we have maps $s, t : R \rightarrow E^*$ and R generates the set of rewriting paths, that we denote R^* . Moreover, for any two elements f and g of R^* (with suitable sources and targets) we can form two composites: $f \bullet_1 g$, which corresponds to applying f followed by g , but also $f \bullet_0 g$, which corresponds to applying f and g in parallel to the same word.

$$f \bullet_1 g = \begin{array}{c} \begin{array}{ccc} & u & \\ & \Downarrow f & \\ \text{---} v \text{---} & \longrightarrow & \\ & \Downarrow g & \\ & w & \end{array} \\ \end{array} \quad f \bullet_0 g = \begin{array}{c} \begin{array}{ccc} u_1 & & v_1 \\ \text{---} & \Downarrow f & \text{---} \\ u_2 & & v_2 \end{array} \end{array}$$

These compositions equip (E^*, R^*) with a structure of (one object) *2-category*, with elements of E^* forming the 1-cells, and rewriting paths forming the 2-cells. The pair (E, R) on the other hand forms a *2-polygraph*. Polygraphs are presentations for higher-dimensional categories. They were introduced by Street under the name of computads [78] [79], and later by Burroni [18]. A 3-polygraph is the data of a 2-polygraph (E, R) together with a set of generating 3-cells S (that have to be understood as ‘relations between the relation’), with source and target operations $s, t : S \rightarrow R^*$. This data can be arranged in the following way, where the pairs of parallel arrows denote the operations s and t , and the vertical arrows denote the inclusion:

$$\begin{array}{ccccc} E & & R & & S \\ \downarrow & \swarrow & \downarrow & \swarrow & \\ E^* & \longleftarrow & R^* & \longleftarrow & \end{array}$$

A 3-polygraph is said to be a *coherent presentation* of a monoid M if any two parallel equivalence paths are related through a composite of elements of S (and their inverses). Note that it is always possible to extend a convergent presentation (E, R) of a monoid M into a coherent presentation: it suffices to take in S one generating 3-cell for each pair of parallel rewriting paths. Squier’s homotopical theorem describes a more “efficient” coherent presentation of M . In particular, the elements of S correspond to the *critical branchings* of (E, R) . Critical branchings are a particular form of local branchings, and they are furthermore in finite number if both E and R are finite. So Squier’s homotopical theorem proves that a monoid admitting a *finite convergent* presentation also admits a *finite coherent* presentation. This last property is the homotopical finiteness condition defined by Squier. This theorem of Squier is the starting point of what is today called *higher-dimensional rewriting*.

1.2 Higher-dimensional rewriting

1.2.1 Squier’s theory and coherence theorems

Squier’s homotopical theorem deals with the rewriting of monoids. Since then, it has been extended to other kinds of structures, such as algebras [37] or higher-dimensional categories [38] [39]. The latter is particularly interesting because it can be used to prove *coherence theorems* for weak structures. A mathematical structure, such as the notion of monoid or algebra, is often defined as some data satisfying relations. In the case of monoids, the data is a set and a binary application, and the relations are the associativity and the unit axioms. In category theory, one often considers relations that hold only *up to isomorphism*. One of the simplest examples of such a structure is that of monoidal categories, in which the product is not associative, but instead there exist isomorphisms $\alpha_{A,B,C} : (A \otimes B) \otimes C \rightarrow A \otimes (B \otimes C)$. This additional data must also satisfy a relation, known as Mac Lane’s pentagon:

$$\begin{array}{ccc}
 & (A \otimes (B \otimes C)) \otimes D & \xrightarrow{\alpha_{A,B \otimes C,D}} & A \otimes ((B \otimes C) \otimes D) \\
 \alpha_{A,B,C} \otimes D \nearrow & & & \searrow A \otimes \alpha_{B,C,D} \\
 ((A \otimes B) \otimes C) \otimes D & = & & A \otimes (B \otimes (C \otimes D)) \\
 \alpha_{A \otimes B,C,D} \searrow & & & \nearrow \alpha_{A,B,C \otimes D} \\
 & (A \otimes B) \otimes (C \otimes D) & &
 \end{array}$$

The intended purpose of this relation is that, between any two bracketings of $A_1 \otimes \dots \otimes A_n$, there exists a *unique* isomorphism constructed from the isomorphisms $\alpha_{A,B,C}$. This statement was made precise and proved by Mac Lane in the case of monoidal categories [59]. In general a *coherence theorem* contains a description of a certain class of diagrams that are to commute. Coherence theorems exist for various other structures, for example bicategories [61], or \mathcal{V} -natural transformations for a symmetric monoidal closed category \mathcal{V} [52].

Coherence results are often the consequence of (arguably more essential [51]) *strictification theorems*. A strictification theorem states that a “weak” structure is equivalent to a “strict” (or at least “stricter”) one. For example, any bicategory is biequivalent to a 2-category, and the same is true for pseudofunctors (this is a consequence of a general strictification result from [70]). It does not hold however for pseudonatural transformations.

Squier’s theory is also well-adapted to prove coherence results since the purpose of a coherent presentation is precisely that “every two equivalence paths are equal up to a higher relation”. Let us consider for example the structure of a category equipped with a weakly associative tensor product. The way to apply Squier’s theory is to encode the structure of category equipped with an associative tensor product into a 4-polygraph **Assoc**. This 4-polygraph contains one generating 2-cell ∇ coding for the product, and we see the associativity isomorphism as a rewriting relation given by a 3-cell $\nabla : \nabla \Rightarrow \nabla$. Finally, MacLane’s pentagon corresponds

to a 4-cell \Downarrow of the following shape:

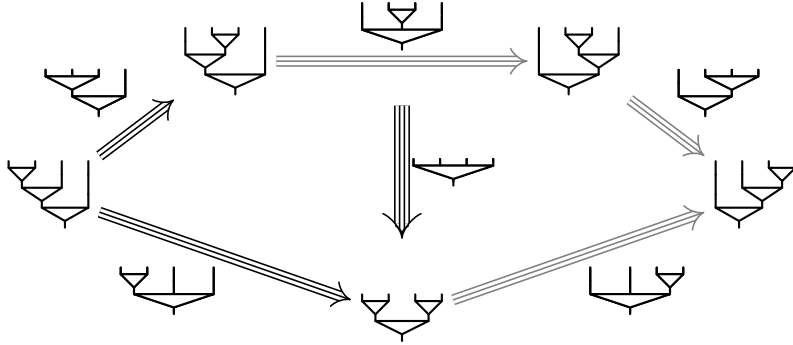

In this setting, the coherence result for categories equipped with an associative product amounts to showing that any two parallel equivalence paths (built from the cells \Downarrow) are equal up to a composite of cells \Downarrow .

1.2.2 Resolutions of monoids and categorification

Squier’s theorem was also extended to build *resolutions* of monoids, instead of just coherent presentations. In order to justify this shift, let us talk for a moment about categorification. The term *categorification* was coined by Crane [23] [22], and it refers to the general idea of finding category-theoretic analogues of concepts coming from set-theory. An element of a set then becomes an object of a category, and an equation becomes an isomorphism. Monoidal categories are a categorification of monoids, and finite sets can be seen as a categorification of natural numbers. One interesting observation is that many deep results can be seen as categorified versions of set-theoretic facts. The coherence theorem for monoidal categories is an example of this. To understand this phenomenon, let us recall the following parable about categorification given by Baez and Dolan in [5]:

Long ago, when shepherds wanted to see if two herds of sheep were isomorphic, they would look for an explicit isomorphism. In other words, they would line up both herds and try to match each sheep in one herd with a sheep in the other. But one day, along came a shepherd who invented decategorification. She realized one could take each herd and ‘count’ it, setting up an isomorphism between it and some set of ‘number’, which were nonsense words like ‘one, two, three, ...’ specially designed for this purpose. By comparing the resulting numbers, she could show that two herds were isomorphic without explicitly establishing an isomorphism! In short, by decategorifying the category of finite sets, the set of natural numbers was invented.

Note however that apart from some specific cases, there is no general notion of what *the* categorification of a concept is, and in some cases there may exist multiple ones. For example, the categorification of commutative monoids can equally be seen as being symmetric monoidal categories, or braided monoidal categories.

To see how this is relevant to our setting, let us consider a monoid M acting on a category \mathcal{C} . This means that for any $m \in M$ we have an endofunctor $[m]_{\mathcal{C}} : \mathcal{C} \rightarrow \mathcal{C}$, such that for all $m, n \in M$, $[m]_{\mathcal{C}} \circ [n]_{\mathcal{C}} = [mn]_{\mathcal{C}}$ and $[1]_{\mathcal{C}} = 1_{\mathcal{C}}$. Suppose now that \mathcal{C} is equivalent to a category \mathcal{D} . This means that there exist functors $F : \mathcal{C} \rightarrow \mathcal{D}$ and $G : \mathcal{D} \rightarrow \mathcal{C}$ together with natural isomorphisms $F \circ G \cong 1_{\mathcal{D}}$ and $G \circ F \cong 1_{\mathcal{C}}$. The problem is the following (see [56] for a general exposition about similar problems, or [86] for a more gentle introduction):

Problem 1.2.2.1. *Is it possible to transfer the action of M on \mathcal{C} to an action of M on \mathcal{D} ?*

One way of doing this would be to define $[m]_{\mathcal{D}} = F \circ [m]_{\mathcal{C}} \circ G$. However, notice that the equality $[m]_{\mathcal{D}} \circ [n]_{\mathcal{D}} = [mn]_{\mathcal{D}}$ does not hold. Instead, we get *natural isomorphisms* of the form:

$$[m]_{\mathcal{D}} \circ [n]_{\mathcal{D}} = F \circ [m]_{\mathcal{C}} \circ G \circ F \circ [n]_{\mathcal{C}} \circ G \cong F \circ [m]_{\mathcal{C}} \circ [n]_{\mathcal{C}} \circ G = F \circ [mn]_{\mathcal{C}} \circ G = [mn]_{\mathcal{D}}$$

In turn, these natural isomorphisms will themselves satisfy some equations. In the end, we do not get an action of M on \mathcal{D} . However, we get an action of the 2-category presented by the *standard coherent presentation* of M on \mathcal{D} . The 2-category presented by a coherent presentation (E, R, S) of M is the 2-category obtained by identifying any two parallel equivalence paths.² If we want to extend this solution to actions of monoids on higher categories, with a weaker notion of equivalence, then the equations between the natural isomorphisms will only hold up to a higher morphism. In order to account for that, we use the notion of *resolution* of a monoid M .

Recall that an $(\omega, 1)$ -category is a (strict) ω -category where all the k -cells are invertible, for $k \geq 2$. Then an $(\omega, 1)$ -polygraph is a system of generators for an $(\omega, 1)$ -category. If Σ is such an $(\omega, 1)$ -polygraph, then the $(\omega, 1)$ -category it generates has as (uninvertible) 1-cells the words on Σ_1 , and as (invertible) 2-cells sequences formed of elements of Σ_2 and of their inverses (they correspond to the equivalence paths in the setting of string rewriting). Then a *resolution* of a monoid M is an $(\omega, 1)$ -polygraph such that (Σ_1, Σ_2) forms a presentation of Σ , and for any two parallel n -cells f and g in the $(\omega, 1)$ -category generated by Σ (with $n \geq 2$), there exists an $(n+1)$ -cell $f \rightarrow g$. Using the machinery of the model structure on $(\omega, 1)$ -categories [55], Σ forms a *cofibrant replacement* of M (where we see M as a one-object $(\omega, 1)$ -category).

In [40], Guiraud and Malbos extended Squier's homotopical theorem, proving that, starting from a convergent presentation (E, R) of a monoid M , it is possible to extend that presentation into a resolution Σ of M , such that the $(n+1)$ -cells of Σ correspond to the n -fold critical branchings. In particular, those critical branchings are in finite number if (E, R) is finite, leading to a refinement of Squier's homotopical finiteness condition.

²To be more precise, we should talk about the $(2, 1)$ -category presented. Otherwise, we are only considering rewriting paths and not equivalence paths.

1.3 Coherence through higher-dimensional rewriting

The rest of this introduction presents an outline of the content of this thesis. In this section, we focus on Chapters 2 and 3. In Chapter 2, we start by recalling a number of classical definitions and results of higher-dimensional rewriting, and we apply them to prove coherence theorems for bicategories and pseudofunctors. Then in Chapter 3, we prove a coherence theorem for pseudonatural transformations. We will see that the techniques from Chapter 2 fail in this case. In order to overcome this difficulty, we prove a Squier-like theorem adapted to our needs.

1.3.1 Rewriting and polygraphs

Recall that an (n, p) -category is a category where all k -cells are invertible, for $k > p$. In particular, $(n, 0)$ -categories are commonly called n -groupoids, and (n, n) -categories are just n -categories. There is a corresponding notion of (n, p) -polygraph. If Σ is an (n, p) -polygraph, we denote by $\Sigma^{*(p)}$ the free (n, p) -category generated by Σ , or simply Σ^* if $p = n$. All those definitions are made precise in Section 2.1.

To illustrate the content of Chapter 2, let us go back to the 4-polygraph **Assoc** described in Section 1.2.1. As we said, this polygraph encodes the structure of a category equipped with a weakly associative tensor product. Let us consider the $(4, 2)$ -category generated by **Assoc**, that we denote **Assoc**^{*(2)}. It has one object, its 1-cells are freely generated by $|$ (and so are in bijections with the integers). Its 2-cells are generated by ∇ (so they are forests of binary trees). Its 3-cells are the equivalence paths of the associativity relation \triangleleft and its 4-cells are generated by $\triangleleft\triangleleft$. To understand how **Assoc** encodes the structure of a category equipped with a weakly associative tensor product, let us define another $(4, 2)$ -category.

Recall first that there is a $(2, 1)$ -category **Cat**, whose objects are categories, morphisms are functors, and 2-cells are natural isomorphisms (so the 2-cells are invertible). We can therefore see **Cat** as a $(3, 1)$ -category, where all the 3-cells are identities. Moreover, the cartesian product makes **Cat** into a monoidal 3-category. By delooping, we can see **Cat** as a $(4, 2)$ -category with one object. The 1-cells are categories, and the “0-composite” of two categories \mathcal{C} and \mathcal{D} is the category $\mathcal{C} \times \mathcal{D}$.

Let us now understand what a functor (of $(4, 2)$ -categories) F from **Assoc**^{*(2)} to **Cat** is. On 0-cells, F has to send the unique object of **Assoc** to the unique object of **Cat**. On 1-cells, F sends the cell $|$ to a category, that we denote \mathcal{C} . As a consequence, F sends the 1-cell of length n of **Assoc**^{*(2)} to $\mathcal{C}^{\times n}$. So on 2-cells, F sends the 2-cell $\nabla : | | \Rightarrow |$ to a functor $\otimes : \mathcal{C} \times \mathcal{C} \rightarrow \mathcal{C}$. As our notation suggests, the 3-cell \triangleleft is sent to a natural isomorphism α , which shows that \otimes is associative up to isomorphism. Finally, the 4-cell $\triangleleft\triangleleft$ is sent by F to an identity, which means that α has to satisfy the pentagon equation. What we just showed is that the data of $F : \mathbf{Assoc}^{*(2)} \rightarrow \mathbf{Cat}$ is equivalent to the data of a category equipped with a weakly associative tensor product. In Section 2.3 and 3.1, we extend this correspondence to bicategories, pseudofunctors and pseudonatural transformations between them.

Let us show what this correspondence means for coherence. The coherence result about categories equipped with a weakly associative tensor product states that all formal composite of the natural isomorphisms α are equal. But such formal composites correspond exactly to equivalence paths in **Assoc**^{*(2)}. So in the end, the coherence theorem is equivalent to saying that **Assoc** is 3-coherent, that is between every pair of parallel 3-cells A, B in **Assoc**^{*(2)}, there exists a 4-cell $\alpha : A \Rrightarrow B$ in **Assoc**^{*(2)}.

In order to prove that **Assoc**^{*(2)} is 3-coherent, we rely on the properties of confluence and termination of the rewriting system generated by \triangleleft . The precise definitions of confluence and termination in this context can be found in Section 2.2.

To prove that confluence and termination imply 3-coherence, we rely on a version of Squier’s theorem for rewriting in 2-categories proved in [38]. Stating Squier’s theorem requires the notion of *critical branchings*. Those are defined in Section 2.2.2. A local branching in **Assoc** is a pair of rewriting steps of same source. Local branchings are ordered by adjunction of context, that is a branching (f, g) is smaller than a branching $(u \star_i f \star_i v, u \star_i g \star_i v)$ for any 2-cells u and v and $i = 0, 1$. There are three types of local branchings:

- A branching of the form (f, f) is called *aspherical*.
- A branching of the form $(f \star_i s(g), s(f) \star_i g)$ for $i = 0$ or 1 is called a *Peiffer branching*.
- Otherwise, (f, g) is called an *overlapping branching*.

Overlapping branchings that are also minimal are called *critical branchings*.

There is exactly one critical branching in **Assoc**, of source . Note that the critical pair appears as the 2-source of the generating 4-cell of **Assoc**. In particular there is a one-to-one correspondence between generating 4-cells and critical pairs. A 3-convergent 4-polygraph that satisfies this property is said to satisfy the *3-Squier condition*.

Proposition 4.3.4 in [38] states that a 4-polygraph satisfying the 3-Squier condition is 3-coherent (and more generally, that any $(n + 1)$ -polygraph satisfying the n -Squier condition is n -coherent). In particular, the 4-polygraph **Assoc** satisfies the 3-Squier condition, so it is 3-coherent.

As an application of the theory recalled in this chapter, we prove coherence theorems for bicategories and pseudofunctors. To this end, we exhibit in Section 2.3, for any sets **C** and **D** and any application $\mathbf{f} : \mathbf{C} \rightarrow \mathbf{D}$ two 4-polygraphs **BiCat**[**C**] and **PFonct**[**f**] presenting respectively the structures of “bicategories whose set of objects is **C**” and “pseudofunctor whose map between sets of objects is **f**”. Applying the same reasoning as the one we just presented for **Assoc**, we prove our first two results:

Theorem 2.3.1.6 (Coherence for bicategories). *Let **C** be a set.*

*The 4-polygraph **BiCat**[**C**] is 3-convergent and the free $(4, 2)$ -category **BiCat**[**C**]^{*(2)} is 3-coherent.*

Theorem 2.3.2.7 (Coherence for pseudofunctors). *Let **C** and **D** be sets, and $\mathbf{f} : \mathbf{C} \rightarrow \mathbf{D}$ an application.*

*The 4-polygraph **PFonct**[**f**] is 3-convergent and the free $(4, 2)$ -category **PFonct**[**f**]^{*(2)} is 3-coherent.*

The goal of Chapter 3 is to prove a similar result for pseudonatural transformations. However, the approach developed in Chapter 2 fails, because the $(4, 2)$ -polygraph **PNTrans**[**f, g**] (where **f** and **g** are applications $\mathbf{C} \rightarrow \mathbf{D}$) encoding the structure of pseudonatural transformation is not 3-confluent.

1.3.2 The 2-Squier condition of depth 2

In order to circumvent this difficulty, we introduce the notion of *2-Squier condition of depth 2*. We say that a $(4, 2)$ -polygraph Σ satisfies the 2-Squier condition of depth 2 if it satisfies the 2-Squier condition, and if the 4-cells of Σ correspond to the critical *triples* induced by the 2-cells (with a prescribed shape).

For example, the 4-polygraph **Assoc** satisfies the 2-Squier condition of depth 2: its underlying 2-polygraph is both 2-terminating and 2-confluent. Moreover, the only critical pair

corresponds to the associativity 3-cell. Finally, Mac Lane’s pentagon can be written as follows, which shows that it corresponds to the only critical triple:

We prove the following result about $(4, 2)$ -polygraph satisfying the 2-Squier condition of depth 2:

Theorem 3.1.3.5. *Let Σ be a $(4, 2)$ -polygraph satisfying the 2-Squier condition of depth 2.*

For every parallel 3-cells $A, B \in \Sigma_3^{(2)}$ whose 1-target is a normal form, there exists a 4-cell $\alpha : A \rightrightarrows B$ in the free $(4, 2)$ -category $\Sigma_4^{*(2)}$.*

Note in particular that the 2-Squier condition of depth 2 does not imply the 3-coherence of the $(4, 2)$ -category generated by the polygraph, but only a partial coherence, “above the normal forms”. For example in the case of **Assoc**, the only normal form is the 1-cell $|$. So Theorem 3.1.3.5 only expresses the coherence of the 3-cells of **Assoc** $^{*(2)}$ whose 1-target is $|$. Conversely, Squier’s theorem as extended in [38] concerns all the 3-cells of **Assoc** $^{*(2)}$, regardless of their 1-target.

The $(4, 2)$ -polygraph $\mathbf{PNTrans}[\mathbf{f}, \mathbf{g}]$ does not satisfy the 2-Squier condition. However, we identify in Section 3.1.3 a sub- $(4, 2)$ -polygraph $\mathbf{PNTrans}^{++}[\mathbf{f}, \mathbf{g}]$ of $\mathbf{PNTrans}[\mathbf{f}, \mathbf{g}]$ that does. By Theorem 3.1.3.5, we get a partial coherence result in $\mathbf{PNTrans}^{++}[\mathbf{f}, \mathbf{g}]^{*(2)}$. The rest of Section 3.1 extends this partial coherence result to the rest of $\mathbf{PNTrans}[\mathbf{f}, \mathbf{g}]^{*(2)}$. To do so, we define a weight application from $\mathbf{PNTrans}[\mathbf{f}, \mathbf{g}]^{*(2)}$ to \mathbb{N} to keep track of the condition on the 1-targets of the 3-cells considered. We thereby prove the following result:

Theorem 3.1.1.8 (Coherence for pseudonatural transformations). *Let \mathbf{C} and \mathbf{D} be sets, and $\mathbf{f}, \mathbf{g} : \mathbf{C} \rightarrow \mathbf{D}$ applications.*

Let $A, B \in \mathbf{PNTrans}[\mathbf{f}, \mathbf{g}]_3^{(2)}$ be two parallel 3-cells whose 1-target is of weight 1.*

There is a 4-cell $\alpha : A \rightrightarrows B \in \mathbf{PNTrans}[\mathbf{f}, \mathbf{g}]_4^{(2)}$.*

1.3.3 Sketch of the proof of Theorem 3.1.3.5

The intuition behind the proof of Theorem 3.1.3.5 is the following. Let Σ be a 3-polygraph satisfying the 2-Squier condition. Then a generating 3-cell of Σ has a shape of the form

The first intuition that one may have to extend Squier’s Theorem would be to consider this 3-cell as a rewriting step. However, in general this approach fails. In particular there is no guarantee that such a rewriting system terminates. A better idea would be to consider A as rewriting the left-hand side of (1.3.2) (that is, the diverging pair (f, g)) into the right-hand side (that is, the confluent pair (f', g')). This way in particular we will be able to make use of the 2-termination of Σ .

In order to make this intuition precise we first introduce the notion of white n -category. Let $j < k < n$ be integers. In an n -category \mathcal{C} , one can define the j -composition of $(k + 1)$ -cells A and B using the k -composition and whiskering by setting:

$$A \star_j B := (A \star_j s_k(B)) \star_k (t_k(A) \star_j B) = (s_k(A) \star_j B) \star_k (A \star_j t_k(B)).$$

This is made possible by the exchange axiom between \star_k and \star_j . A *white n -category* is an n -category in which the exchange axioms between \star_k and \star_0 need not hold (even up to isomorphism) for any $k > 0$. As a result, 0-composition is not defined for k -cells, for $k > 1$. The notion of white 2-category coincides with the notion of sesquicategory (see [80]). In general, white n -categories are categories enriched in $(n - 1)$ -categories, where the category of $(n - 1)$ -categories is equipped with the so-called “funny” tensor product [87].

Most concepts from rewriting have a straightforward transcription in the setting of white categories. In particular in Section 3.2.1, we define the notions of white (n, k) -category and white (n, k) -polygraph. We also give an explicit description of the free white (n, k) -category $\Sigma^{\mathbf{w}(k)}$ generated by a white (n, k) -polygraph Σ .

In this setting, we give a precise definition of the notion of partial coherence. Let \mathcal{C} be a white $(4, 3)$ -category and S be a set of distinguished 2-cells of \mathcal{C} . We call such a pair a *pointed white $(4, 3)$ -category*. We say that \mathcal{C} is S -coherent if for any parallel 2-cells $f, g \in S$ and any 3-cells $A, B : f \rightrightarrows g \in \mathcal{C}$, there exists a 4-cell $\alpha : A \rightrightarrows B \in \mathcal{C}$. In particular any $(4, 3)$ -white category is \emptyset -coherent, and a $(4, 3)$ -white category \mathcal{C} is \mathcal{C}_2 -coherent if and only if it is 3-coherent (where \mathcal{C}_2 is the set of all the 2-cells of \mathcal{C}). Theorem 3.1.3.5 amounts to showing that the free $(4, 2)$ -category $\Sigma^{*(2)}$ is S_Σ -coherent, where S_Σ is the set of all 2-cells whose target is a normal form.

Finally, we give a way to modify partially coherent categories while retaining information about the partial coherence. Let (\mathcal{C}, S) and (\mathcal{C}', S') be pointed white $(4, 3)$ -categories. We define a relation of *strength* between pointed white $(4, 3)$ -categories. We show that if (\mathcal{C}, S) is stronger than (\mathcal{C}', S') , then the S -coherence of \mathcal{C} implies the S' -coherence of \mathcal{C}' .

Let us now return to the proof of Theorem 3.1.3.5. Let us fix a $(4, 2)$ -polygraph \mathcal{A} satisfying the 2-Squier condition of depth 2, and denote by $S_{\mathcal{A}}$ the set of 2-cells whose target is a normal form. In particular, $(\mathcal{A}^{*(2)}, S_{\mathcal{A}})$ is a pointed white $(4, 3)$ -category. The first half of the proof (Section 3.3) consists in applying to $(\mathcal{A}^{*(2)}, S_{\mathcal{A}})$ a series of transformations. At each step, we verify that the new pointed white $(4, 3)$ -category we obtain is stronger than the previous one. In the end, we get a pointed white $(4, 3)$ -category $(\mathcal{F}^{\mathbf{w}(3)}, S_{\mathcal{E}})$, where \mathcal{F} is a white 4-polygraph. In dimension 2, the 2-cells of \mathcal{F} consists of the union of the 2-cells of \mathcal{A} together with their formal inverses. We denote by \bar{f} the formal inverse of a 2-cell $f \in \mathcal{A}^*$. Let \mathcal{F}_3 be the set of 3-cells of \mathcal{F} . It contains 3-cells $C_{f,g}$ for any minimal local branching (f, g) , and cells η_f for any 2-cell $f \in \mathcal{A}$ of the following shape:

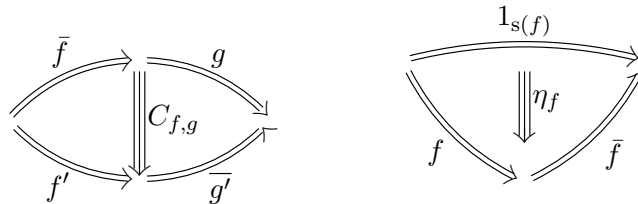

Notice in particular that $C_{f,g}$ corresponds to the cell $A_{f,g}$ of (1.3.2), rotated by 90° . The result of this transformation is that in $\mathcal{F}^{\mathbf{w}(3)}$, for any 2-cells $f, g \in S_E$, the 3-cells of the form $f \Rightarrow g$ (and 4-cells between them) are in one-to-one correspondence with 3-cells of the form $\bar{g} \star_1 f \Rightarrow 1_{\hat{u}}$ (and 4-cells between them), where \hat{u} is the common target of f and g . More generally we study cells of the form $h \Rightarrow 1_{\hat{u}}$, and 4-cells between them.

We start by studying the rewriting system induced by the 3-cells. Note that the white 4-polygraph \mathcal{F} is not 3-terminating, so we cannot use a Squier-like theorem to conclude. However, let $\mathbb{N}[\mathcal{A}_1^*]$ be the free commutative monoid on \mathcal{A}_1^* , the set of 1-cells of \mathcal{A}^* . There is a well-founded ordering on \mathcal{A}_1^* induced by the fact that \mathcal{A} is 2-terminating. This order induces a well-founded ordering on $\mathbb{N}[\mathcal{A}_1^*]$ called the *multiset order*. We define an application $\mathbf{p} : \mathcal{F}_2^{\mathbf{w}} \rightarrow \mathbb{N}[\mathcal{A}_1^*]$ which induces a well-founded ordering on $\mathcal{F}_2^{\mathbf{w}}$, the set of 2-cells of $\mathcal{F}^{\mathbf{w}}$, and show that the cells $C_{f,g}$ are compatible with this ordering (that is, the target of a cell $C_{f,g}$ is always smaller than the source). Thus, the fragment of \mathcal{F}_3 consisting of the cells $C_{f,g}$ is 3-terminating.

The cells η_f however constitute a non-terminating part of $\mathcal{F}_3^{\mathbf{w}}$. To control their behaviour, we introduce a *weight* application $\mathbf{w}_\eta : \mathcal{F}_3^{\mathbf{w}} \rightarrow \mathbb{N}[\mathcal{A}_1^*]$, that essentially counts the number of η_f cells present in a 3-cell. In Section 3.4.3, using the applications \mathbf{p} and \mathbf{w}_η , we prove that for any $h \in \mathcal{F}_2^{\mathbf{w}}$ whose source and target are normal forms (for \mathcal{A}_2), and for any 3-cells $A, B : h \Rightarrow 1_{\hat{u}}$ in $\mathcal{F}_3^{\mathbf{w}}$, there is a 4-cell $\alpha : A \Rrightarrow B$ in $\mathcal{F}^{\mathbf{w}(3)}$. Finally, we prove that this implies that $\mathcal{F}^{\mathbf{w}(3)}$ is $S_{\mathcal{E}}$ -coherent, which concludes the proof.

1.3.4 Conclusion of Chapter 3

The combinatorics of the proof of Theorem 3.1.3.5 is convoluted enough that a generalisation of these techniques seems dubious. Still, let us make a few observations. The first observation is that the 2-Squier condition of depth 2 associates to any 3-fold critical branching (f, g, h) a 4-cell $A_{f,g,h}$ which has the shape of a cube (see for example (1.3.1) or (3.1.4)):

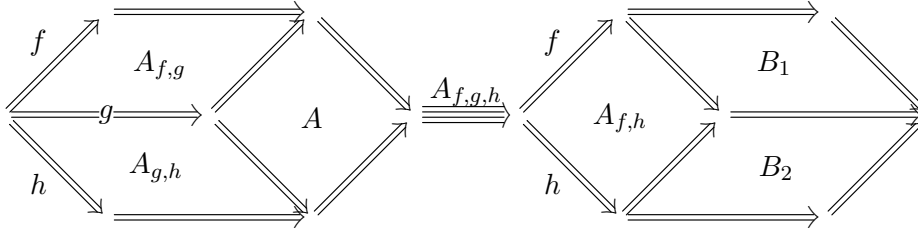

Similarly, the confluence diagram associated to a 4-fold critical branching should have the shape of a hypercube.

Notice that there is an action of the symmetric group \mathfrak{S}_3 on the critical branchings (obtained by permuting the rewriting steps). How does this action of \mathfrak{S}_3 affect the cell $A_{f,g,h}$? If we simply exchange f and h , we get $A_{h,g,f}$, which is just the inverse of $A_{f,g,h}$ with respect to the composition \bullet_2 . Some permutations are more difficult to express in the globular setting, such as $A_{g,f,h}$. If we see $A_{f,g,h}$ as a cube however, then every permutation corresponds to a symmetry of the cube. Understanding this action of \mathfrak{S}_3 is our first clue in finding the link between higher-dimensional rewriting and cubical ω -categories.

The second clue is the appearance of the following cells in Section 3.3:

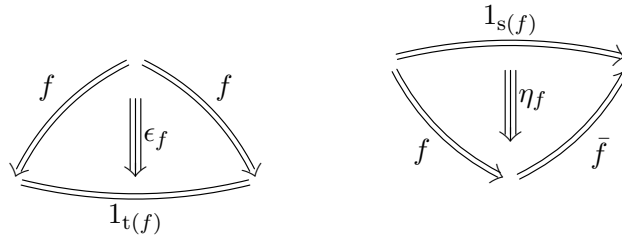

Together with the relations they verify (see (3.3.1) and (3.3.2)), they are very similar to the *connections* of a cubical ω -category (see 4.1). Connections are a type of degeneracies present in cubical ω -categories, which associate to any 1-cell f two 2-cells $\Gamma_1^- f$ and $\Gamma_1^+ f$, which can be represented as follows:

$$\begin{array}{ccc}
 \begin{array}{c} \xrightarrow{f} \\ f \downarrow \Gamma_1^- f \parallel \epsilon_1 y \\ \xrightarrow{\epsilon_1 y} \end{array} & & \begin{array}{c} \xrightarrow{\epsilon_1 x} \\ \epsilon_1 x \parallel \Gamma_1^+ f \downarrow f \\ \xrightarrow{f} \end{array}
 \end{array}$$

The last observation stems from studying the proof of the main theorem from [40]: the proof relies on the construction of a natural transformation (called a *normalisation strategy*) between two ω -categories. The combinatorics of such an object is slightly difficult to describe in globular ω -categories, but it becomes very simple in cubical ω -categories, as shown in Section 4.4.2.

1.4 Cubical ω -categories for rewriting

All these observations motivate us to look at higher-dimensional rewriting from the point of view of cubical ω -categories, which we do in Chapter 5. Before that, the first obstacle on our way is that higher-dimensional rewriting requires the use of (ω, p) -categories, a notion not yet studied in the cubical setting. Chapter 4 is devoted to its study.

1.4.1 Cubical categories and their relationship with other structures

Handling higher structures such as higher categories usually involves conceiving them as conglomerates of cells of a certain shape. Such shapes include simplices, globes or cubes. Simplicial sets have been successfully applied to a wide variety of subjects. For example, they occur in May's work on the recognition principle for iterated loop spaces [64], in Quillen's approach to rational homotopy theory [71], and in Bousfield and Kan's work on completions, localisation, and limits in homotopy theory [11].

Cubical objects however, have had a less successful history until recent years. Although cubical sets were used in early works by Serre [73] and Kan [48], it became quickly apparent that they suffer from a few shortcomings. For instance, cubical groups are not automatically fibrant, and the cartesian product in the category of cubical sets fails to have the correct homotopy type. As a result, cubical sets mostly fell out of fashion in favour of simplicial sets. However later work on double groupoids, by Brown and Higgins, felt the need to add a new type of degeneracies on cubical sets: the so-called connections that we evoked earlier [17] [14]. By using these connections, a number of shortcomings of cubical objects were overcome. In particular the category of cubes with connections is a strict test category [21] [62], and group objects in the category of cubical sets with connections are Kan [83]. Cubical objects with connections were particularly instrumental to the proof of a higher-dimensional Van-Kampen theorem by Brown and Higgins [16]. Other applications of cubical structures arise in concurrency theory [29] [30] [33], type theory [9], algebraic topology [34]. Of interest is also the natural expression of the Gray-Crans tensor product of ω -categories [24] in the cubical setting [3] [2].

A number of theorems relating objects of different shapes exist. For instance, Dold-Kan's correspondence states that in the category of abelian groups, simplicial objects, cubical sets with connections and strict ω -groupoids (globular or cubical with connections) are all equivalent to chain complexes [49] [15].

Outside the category of abelian groups, the relationships between these notions become less straightforward. We are mainly concerned with the two following results:

- The first result is the equivalence between cubical and globular ω -groupoids [12] [14] proven in 1981 by Brown and Higgins. Although this equivalence is useful in theory, in practice it is complicated to make explicit the functors composing this equivalence. This is due to the fact that the proof uses the notion of crossed complexes as a common ground between globular and cubical ω -categories.
- The second result is the equivalence between globular and cubical ω -categories proved in 2002 [2] By Al-Agl, Brown and Steiner.

Lastly in 2004, Steiner [77] introduced the notion of augmented directed complexes (a variant of the notion of chain complexes) and proved the existence of an adjunction between augmented directed complexes and globular ω -categories.

Globular (ω, p) -categories are globular ω -categories where cells of dimension at least $p+1$ are invertible. They form a natural intermediate between globular ω -categories, which correspond to

the case $p = \omega$, and globular ω -groupoids, which correspond to the case $p = 0$. As a consequence, they form a natural setting in which to develop directed algebraic topology [35] or rewriting [40].

However, both directed algebraic topology and rewriting seem to favour the cubical geometry (see once again [38] for directed algebraic topology, and [57] for rewriting), hence the need for a suitable notion of cubical (ω, p) -categories.

The aim of Chapter 4 is to define such a notion, so that when $p = 0$ or $p = \omega$, we respectively recover the notions of cubical ω -groupoids and cubical ω -categories. Moreover, we bridge the gap between two results we cited previously by proving the following theorem:

Theorem 4.3.1.3. *Let $\lambda : \omega\text{-CubCat} \rightarrow \omega\text{-Cat}$ and $\gamma : \omega\text{-Cat} \rightarrow \omega\text{-CubCat}$ be the functors from [2] forming an equivalence of categories between globular and cubical ω -categories. For all $p \geq 0$, their restrictions still induce an equivalence of categories:*

$$\begin{array}{ccc}
 & \lambda & \\
 & \curvearrowright & \\
 (\omega, p)\text{-Cat} & \cong & (\omega, p)\text{-CubCat} \\
 & \curvearrowleft & \\
 & \gamma &
 \end{array}$$

In particular, we recover the equivalence between globular and cubical ω -groupoids in a more explicit fashion.

We also define a notion of (ω, p) -augmented directed complexes and show how to extend Steiner's adjunction. This is done in two steps. First we define functors $\mathcal{Z}^{\mathbf{C}} : \omega\text{-CubCat} \rightarrow \mathbf{ADC}$ and $N^{\mathbf{C}} : \mathbf{ADC} \rightarrow \omega\text{-CubCat}$ (where \mathbf{ADC} is the category of augmented directed complexes), as cubical analogues of the functors $\mathcal{Z}^{\mathbf{G}} : \omega\text{-Cat} \rightarrow \mathbf{ADC}$ and $N^{\mathbf{G}} : \mathbf{ADC} \rightarrow \omega\text{-Cat}$ forming Steiner's adjunction. We study the relationship between both those two pairs of functors and show that the functor $\mathcal{Z}^{\mathbf{C}}$ is left-adjoint to $N^{\mathbf{C}}$ (see Proposition 4.3.2.8). Then we show how to restrict the functors $\mathcal{Z}^{\mathbf{G}}$, $N^{\mathbf{G}}$, $\mathcal{Z}^{\mathbf{C}}$ and $N^{\mathbf{C}}$ to (ω, p) -structures. In the end, we get the following result:

Theorem 4.3.2.12. *Let $\lambda : \omega\text{-CubCat} \rightarrow \omega\text{-Cat}$ and $\gamma : \omega\text{-Cat} \rightarrow \omega\text{-CubCat}$ be the functors from [2] forming an equivalence of categories between globular and cubical ω -categories. Let $\mathcal{Z}^{\mathbf{G}} : \omega\text{-Cat} \rightarrow \mathbf{ADC}$ and $N^{\mathbf{G}} : \mathbf{ADC} \rightarrow \omega\text{-Cat}$ be the functors from [77] forming an adjunction between globular ω -categories and ADCs. Let $\mathcal{Z}^{\mathbf{C}} : \omega\text{-CubCat} \rightarrow \mathbf{ADC}$ and $N^{\mathbf{C}} : \mathbf{ADC} \rightarrow \omega\text{-CubCat}$ be the cubical analogues of $\mathcal{Z}^{\mathbf{G}}$ and $N^{\mathbf{G}}$ defined in Section 4.3.2.*

For all $p \in \mathbb{N} \cup \{\omega\}$, their restrictions induce the following diagram of equivalence and adjunctions between the categories $(\omega, p)\text{-Cat}$, $(\omega, p)\text{-CubCat}$ and $(\omega, p)\text{-ADC}$, where both triangles involving $\mathcal{Z}^{\mathbf{C}}$ and $\mathcal{Z}^{\mathbf{G}}$ and both triangles involving $N^{\mathbf{C}}$ and $N^{\mathbf{G}}$ commute up to isomorphism:

$$\begin{array}{ccc}
 (\omega, p)\text{-Cat} & \begin{array}{c} \xrightarrow{\lambda} \\ \xleftarrow{\cong} \\ \xrightarrow{\gamma} \end{array} & (\omega, p)\text{-CubCat} \\
 \swarrow \mathcal{Z}^{\mathbf{G}} & & \searrow N^{\mathbf{C}} \\
 & & \swarrow \mathcal{Z}^{\mathbf{C}} \\
 & & (\omega, p)\text{-ADC} \\
 & \nearrow N^{\mathbf{G}} & \nwarrow \mathcal{Z}^{\mathbf{C}} \\
 & & (\omega, p)\text{-ADC}
 \end{array}$$

1.4.2 Invertibility in cubical categories

The main combinatorial difficulty of Chapter 4 consists in defining the appropriate notion of invertibility in cubical ω -categories. Before giving an account of the various invertibility notions that we consider in the cubical setting, we start by recalling the more familiar notion of invertibility in $(2, 1)$ -categories.

Informally, a globular (ω, p) -category is a globular ω -category in which every n -cell is invertible, for $n > p$. For this definition to make rigorous sense, one first needs to define an appropriate notion of *invertible* n -cells. Let us fix a globular 2-category \mathcal{C} . There are two ways to compose two 2-cells A and B in \mathcal{C}_2 , that we denote by \bullet_1 and \bullet_0 and that are respectively known as the *vertical* and *horizontal* compositions. They can respectively be represented as follows:



We denote by $I_0f : y \rightarrow x$ the inverse (if it exists) of a 1-cell $f : x \rightarrow y$ in \mathcal{C}_1 . A 2-cell $A \in \mathcal{C}_2$ can have two inverses (one for each composition), that we denote respectively by I_1A and I_0A . Their source and targets are as follows:

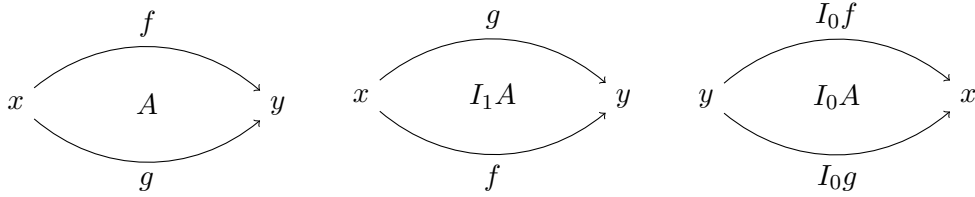

Note that if a 2-cell is I_0 -invertible, then so are its source and target, but that the I_1 -invertibility of a 2-cell does not imply any property for its source and target. So if \mathcal{C} is a 2-category where every 2-cell is I_0 -invertible, then \mathcal{C} is a globular 2-groupoid (indeed, a cell $1_f \in \mathcal{C}_2$ is I_0 -invertible if and only if f is I_0 -invertible). Therefore, we say that a 2-cell is invertible if it is I_1 -invertible, and \mathcal{C} is a globular $(2, 1)$ -category if each 2-cell is I_1 -invertible.

In a cubical 2-category \mathbf{C} (in what follows, cubical categories are always equipped with connections), the source and target of a 1-cell $f \in \mathbf{C}_1$ are respectively denoted $\partial_1^- f$ and $\partial_1^+ f$, and the source and target operations $s, t : \mathcal{C}_2 \rightarrow \mathcal{C}_1$ are replaced by four *faces operations* $\partial_i^\alpha : \mathbf{C}_2 \rightarrow \mathbf{C}_1$ (for $i = 1, 2$ and $\alpha = \pm$), satisfying the cubical identity $\partial_1^\alpha \partial_2^\beta = \partial_1^\beta \partial_1^\alpha$. A 2-cell $A \in \mathbf{C}_2$ can be represented as follows, where the corners of the square are uniquely defined 0-cells thanks to the cubical identity:

$$\begin{array}{ccc} & \xrightarrow{\partial_1^- A} & \\ \partial_2^- A \downarrow & A & \downarrow \partial_2^+ A \\ & \xrightarrow{\partial_1^+ A} & \end{array}$$

There still are two ways to compose two 2-cells $A, B \in \mathbf{C}_2$, that we denote respectively by $A \star_1 B$ and $A \star_2 B$, which can be represented as follows:

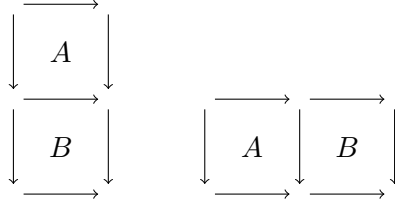

We say that a 2-cell $A \in \mathbf{C}_2$ is R_i -invertible if it is invertible for the composition \star_i ($i = 1, 2$). The faces of R_1A and R_2A are as follows (where $R_1f : y \rightarrow x$ denotes the inverse of a 1-cell $f : x \rightarrow y$):

$$\begin{array}{ccc}
\begin{array}{ccc} x & \xrightarrow{f} & y \\ h \downarrow & A & \downarrow i \\ z & \xrightarrow{g} & t \end{array} & \begin{array}{ccc} z & \xrightarrow{g} & t \\ R_1h \downarrow & R_1A & \downarrow R_1i \\ x & \xrightarrow{f} & y \end{array} & \begin{array}{ccc} y & \xrightarrow{R_1f} & x \\ i \downarrow & R_2A & \downarrow h \\ t & \xrightarrow{R_1g} & z \end{array}
\end{array}$$

Note that contrary to the notion of I_1 -invertibility, the R_1 and R_2 -invertibility of A require respectively that $\partial_2^\alpha A$ and $\partial_1^\alpha A$ are R_1 -invertible (for $\alpha = \pm$). We say that A has respectively an R_1 or an R_2 -invertible shell if that is the case. As a consequence, if \mathbf{C} is a cubical 2-category where every 2-cell is R_1 -invertible, then every 1-cell of \mathbf{C} is R_1 -invertible (one can even show that such a cubical 2-category is actually a cubical 2-groupoid) and the same property holds for R_2 . In order to have a good notion of cubical (ω, p) -categories nonetheless, we have to be more careful in our definition of an invertible cell.

This is done in Section 4.2.1, where we define a notion of invertibility for an n -cell ($n \geq 1$). Let us first recall that, using the structure of connections on \mathbf{C} , one can associate to any 1-cell $f : x \rightarrow y$ in \mathbf{C}_1 , the cells $\Gamma_1^- f$ and $\Gamma_1^+ f$, which can be represented as follows:

$$\begin{array}{ccc}
\begin{array}{ccc} x & \xrightarrow{f} & y \\ f \downarrow & \Gamma_1^- f & \parallel \epsilon_1 y \\ y & \xrightarrow{\epsilon_1 y} & y \end{array} & & \begin{array}{ccc} x & \xrightarrow{\epsilon_1 x} & x \\ \epsilon_1 x \parallel & \Gamma_1^+ f & \downarrow f \\ x & \xrightarrow{f} & y \end{array}
\end{array}$$

We say that a 2-cell $A \in \mathbf{C}_2$ is invertible if the following composite (denoted $\psi_1 A$) is R_1 -invertible:

$$\begin{array}{ccc}
\begin{array}{c} \xrightarrow{\quad} \\ \parallel \\ \Gamma_1^+ \partial_2^- A \\ \parallel \\ \xrightarrow{\quad} \end{array} & \begin{array}{c} \xrightarrow{\quad} \\ A \\ \xrightarrow{\quad} \end{array} & \begin{array}{c} \xrightarrow{\quad} \\ \parallel \\ \Gamma_1^- \partial_2^+ A \\ \parallel \\ \xrightarrow{\quad} \end{array}
\end{array}$$

Note in particular that $\partial_2^- \psi_1 A$ and $\partial_2^+ \psi_1 A$ are both identities (which are always invertible), and so the R_1 -invertibility of $\psi_1 A$ does not require the invertibility of any face of A . The link between invertibility, R_i -invertibility and having an R_i -invertible shell is given by the following proposition:

Proposition 4.2.2.2. *Let \mathbf{C} be a cubical ω -category, $A \in \mathbf{C}_n$ and $1 \leq j \leq n$. A cell $A \in \mathbf{C}_n$ is R_j -invertible if and only if A is invertible and has an R_j -invertible shell.*

We also investigate in Section 4.2.3 another notion of invertibility, with respect to a kind of “diagonal” composition, that we call the T_i -invertibility. If A is a 2-cell in a cubical 2-category, then the T_1 -inverse of A (if it exists) has the following faces:

$$\begin{array}{ccc} x & \xrightarrow{f} & y \\ h \downarrow & A & \downarrow i \\ z & \xrightarrow{g} & t \end{array} \quad \begin{array}{ccc} x & \xrightarrow{h} & z \\ f \downarrow & T_1 A & \downarrow g \\ y & \xrightarrow{i} & t \end{array}$$

We then define a suitable notion of T_i -invertible shells and prove the following result, analogous to Proposition 4.2.2.2:

Proposition 4.2.3.5. *Let \mathbf{C} be a cubical ω -category, and $A \in \mathbf{C}_n$, with $n \geq 2$. Then A is T_i -invertible if and only if A is invertible and has a T_i -invertible shell.*

The study of the relationship between R_i -invertibility, T_i -invertibility and (plain) invertibility gives rise to the following Proposition:

Proposition 4.3.1.2. *Let \mathbf{C} be a cubical ω -category, and fix $n > 0$. The following five properties are equivalent:*

1. Any n -cell in \mathbf{C}_n is invertible.
2. For all $1 \leq i \leq n$, any n -cell in \mathbf{C}_n with an R_i -invertible shell is R_i -invertible.
3. Any n -cell in \mathbf{C}_n with an R_1 -invertible shell is R_1 -invertible.
4. Any n -cell $A \in \mathbf{C}_n$ such that $\partial_j^\alpha A \in \mathbf{Im} \epsilon_1$ for all $j \neq 1$ is R_1 -invertible.
5. Any n -cell in $\Phi_n(\mathbf{C}_n)$ is R_1 -invertible.

Moreover, if $n > 1$, then all the previous properties are also equivalent to the following:

6. For all $1 \leq i < n$, any n -cell in \mathbf{C}_n with a T_i -invertible shell is T_i -invertible
7. Any n -cell in \mathbf{C}_n with a T_1 -invertible shell is T_1 -invertible.

We can now define a cubical (ω, p) -category as a cubical ω -category where every n -cell is invertible, for $n > p$, and we prove the equivalence with the globular notion.

1.4.3 Permutations and cubical (ω, p) -categories

In Section 4.4.1, we extend the notion of the T_i -invertibility of an n -cell to that of the σ -invertibility, for σ an element of the symmetric group \mathfrak{S}_n . In particular, we show that if \mathbf{C} is a cubical $(\omega, 1)$ -category, then every cell of \mathbf{C} is T_i -invertible, and therefore σ -invertible, for any $\sigma \in \mathfrak{S}_n$. Consequently, we get an action of the symmetric group \mathfrak{S}_n on the set of n -cells \mathbf{C}_n , making \mathbf{C} a symmetric cubical category (in a sense related to that of Grandis [34]).

In Section 4.4.2, we apply the notion of invertibility to k -transfers between cubical ω -categories. A k -transfer (following terminology by Crans [25]) from \mathbf{C} to \mathbf{D} is a family of applications $\mathbf{C}_n \rightarrow \mathbf{D}_{n+k}$ satisfying some compatibility conditions. These compatibility conditions come in two varieties, leading to the notions of lax and oplax k -transfers (respectively called k -fold left and right homotopies in [2]). In particular, the lax or oplax 0-transfers are just the functors from \mathbf{C} to \mathbf{D} , and a lax or oplax 1-transfer η between functors F and G is the cubical

analogue of a lax or oplax natural transformation from F to G . For example, a 0-cell in $x \in \mathbf{C}_0$ is sent to a 1-cell $\eta_x : F(x) \rightarrow G(x)$ in \mathbf{D}_1 , and a 1-cell $f : x \rightarrow y$ in \mathbf{C}_1 is sent to a 2-cell η_f in \mathbf{D}_2 of the following shape (respectively if η is lax or oplax):

$$\begin{array}{ccc}
 F(x) & \xrightarrow{F(f)} & F(y) \\
 \eta_x \downarrow & \eta_f & \downarrow \eta_y \\
 G(x) & \xrightarrow{G(f)} & G(y)
 \end{array}
 \qquad
 \begin{array}{ccc}
 F(x) & \xrightarrow{\eta_x} & G(x) \\
 F(f) \downarrow & \eta_f & \downarrow G(f) \\
 F(y) & \xrightarrow{\eta_y} & G(y)
 \end{array}$$

As shown in [2], Section 10, lax and oplax transforms from \mathbf{C} to \mathbf{D} respectively form cubical ω -categories $\mathbf{Lax}(\mathbf{C}, \mathbf{D})$ and $\mathbf{OpLax}(\mathbf{C}, \mathbf{D})$. We define notions of pseudo transforms as transforms satisfying some invertibility conditions. In particular in the case of 1-transforms, we require for any 1-cell f in \mathbf{C}_1 that η_f is T_1 -invertible. We show that pseudo lax and pseudo oplax transforms from \mathbf{C} to \mathbf{D} still form cubical ω -categories $\mathbf{PsLax}(\mathbf{C}, \mathbf{D})$ and $\mathbf{PsOpLax}(\mathbf{C}, \mathbf{D})$, and prove the following result:

Proposition 4.4.2.6. *For all cubical ω -categories \mathbf{C} and \mathbf{D} , the cubical ω -categories $\mathbf{PsLax}(\mathbf{C}, \mathbf{D})$ and $\mathbf{PsOpLax}(\mathbf{C}, \mathbf{D})$ are isomorphic.*

For example if η is a lax 1-transform, then the application $\mathbf{C}_1 \rightarrow \mathbf{D}_2$ which is part of the oplax 1-transform associated to η maps a cell f in \mathbf{C}_1 to a 2-cell $T_1\eta_f$ in \mathbf{D}_2 .

1.5 Higher-dimensional rewriting in cubical categories

The goal in Chapter 5 is to apply the structure of cubical (ω, p) -category developed in Chapter 4 to higher dimensional rewriting. As we will see this approach greatly simplifies the proof techniques from [40], allowing us to prove theorems which were unattainable by other means. Before stating those results, let us go back to the categorification problem that we evoked earlier.

1.5.1 Model structure and the Gray tensor product

As we saw, higher dimensional rewriting can be applied to many different structures. Squier's theorem dealt with rewriting in monoids. In Chapters 2 and 3 we were interested in rewriting in 2-categories with a fixed set of objects and arrows. Squier-like theorems also exist for algebras [37]. One natural question is whether it is possible to find a suitable framework that encompasses all those results. The idea we propose is to see monoids and 2-categories (with a fixed set of objects and arrows) as algebras over (set-theoretic) operads. In order to see Squier-like theorems as categorification results (as in Section 1.2.2) however, we need to have a model structure on \mathcal{O} -algebras in ω -groupoids, for any operad \mathcal{O} (although throughout Chapter 5 we only work in the case where \mathcal{O} is the operad of monoids).

More precisely, we would like to use the adjunction between \mathcal{O} -algebras in ω -groupoids and ω -groupoids in order to lift the model structure from ω -groupoids to \mathcal{O} -algebras in ω -groupoids. Multiple sufficient conditions exist in the literature to perform this kind of transfer (see for example [72], [44] or [8]). They all have in common that ω -groupoids have to form a *monoidal model category*. A monoidal model category is a biclosed monoidal category equipped with a model structure such that the product and the model structure interact nicely together. In particular, it has to satisfy the pushout-product axiom, see Section 5.1.2.

However, ω -groupoids equipped with the cartesian product do not form a monoidal model category, as noted by Lack [54]. As for the Gray tensor product, whether it makes ω -groupoids into a monoidal model category is still an open problem. This seems like a reasonable conjecture given that Lack proved in [54] that the pseudo Gray tensor product equips 2-categories with a monoidal model structure. Unfortunately we fall short of proving the result for ω -groupoids, but we still show in Section 5.1.2 that part of the pushout-product is satisfied. This has in particular the nice consequence that the Gray tensor product of two free ω -groupoids is still free, a fact that will be useful later on. Remark also that the apparition of the Gray tensor product here reinforces our intuition that cubical ω -categories are the right setting for studying higher-dimensional rewriting.

The first step towards this goal is to find a suitable notion of polygraphs for Gray monoids (where Gray monoids are monoid objects in ω -groupoids, equipped with the Gray tensor product). Thankfully, a general result by Garner [28] allows us to do this, using the fact that Gray monoids are monadic over pre-cubical sets. We call a Gray polygraph this associated notion of polygraph. Let us look again at the presentation of B_3^+ from Section 1.1.2. In the setting of Gray monoids, it corresponds to a Gray polygraph Σ such that $\Sigma_0 = \{s, t\}$, the 0-cells of the Gray monoid generated by Σ are denoted $\Sigma_0^{G(0)}$: they form the words on the alphabet Σ_0 . Just as for globular polygraphs, the set Σ_1 is formed by the cells α, β, γ and δ (with the same sources and targets), and $\Sigma_1^{G(0)}$ is formed of all the equivalence paths. There is one main difference with the globular setting though, which stems from the fact that we use the Gray tensor product. Indeed, while in the globular setting we were able to compose two rewriting steps $f : u \rightarrow u'$ and $g : v \rightarrow v'$ in parallel using the composition \bullet_0 , this operation is not available in Gray monoids. Instead, there exists a 2-cell $f \otimes g$ relating the two composites: the one corresponding to doing

f followed by g and the one corresponding to g followed by f :

$$\begin{array}{ccc}
 uv & \xrightarrow{ug} & uv' \\
 fv \downarrow & f \otimes g & \downarrow fv' \\
 u'v & \xrightarrow{u'g} & u'v'
 \end{array}
 \qquad
 \begin{array}{ccc}
 & ug & \curvearrowright uv' & \xrightarrow{fv'} & \\
 uv & \xrightarrow{fg} & & \xrightarrow{fg} & uv' \\
 & fv \curvearrowleft & u'v & \xrightarrow{u'g} & \\
 & & & &
 \end{array}$$

The consequence of that is that in Gray monoids, the rewriting paths form the *free groupoid on the rewriting steps*. This is actually a special case of a more general phenomenon: starting from a Gray polygraph Σ , we can look at $\Sigma^{G(0)}$ the Gray monoid generated by Σ . If we forget about the monoid structure, then we get an ω -groupoid. We prove in Section 5.1.2 that this ω -groupoid is also free, over an $(\omega, 0)$ -polygraph that we denote $[\Sigma]$. In other words, we have an isomorphism of ω -groupoids $\Sigma^{G(0)} \cong [\Sigma]^{*(0)}$. In the case where Σ is the presentation of B_3^+ , then $[\Sigma]_0$ is the set of words of Σ_0 , while $[\Sigma]_1$ is the set of all rewriting steps formed from the elements of Σ_1 .

1.5.2 The two versions of Squier's theorem

In order to understand the main theorem of Chapter 5, we first need to analyse Squier's homotopical theorem more closely. Squier's homotopical theorem can be phrased in two different ways, that we call respectively the Existence and the Detection Theorem:

Theorem 1.5.2.1 (Existence Theorem). *Let Σ be a convergent 2-polygraph. Then there exists an extension of Σ into a 3-polygraph such that:*

- The 3-cells of Σ correspond to the critical branchings.
- The 3-polygraph Σ forms a coherent presentation of M , the monoid presented by Σ .

Theorem 1.5.2.2 (Detection Theorem). *Let Σ be a terminating 3-polygraph. Suppose that for any critical branching (f, g) in Σ , there exists a cell $A \in \Sigma_3$ of the following shape:*

$$\begin{array}{ccc}
 \begin{array}{ccc}
 \xrightarrow{f} & & \\
 \curvearrowright & & \curvearrowleft \\
 \xrightarrow{g} & & \\
 \curvearrowleft & & \curvearrowright
 \end{array}
 &
 \begin{array}{c}
 \text{|||} \\
 A \\
 \Downarrow
 \end{array}
 &
 \begin{array}{ccc}
 & & \\
 \curvearrowright & & \curvearrowleft \\
 & & \\
 \curvearrowleft & & \curvearrowright
 \end{array}
 \end{array}
 \tag{1.5.1}$$

The Σ forms a coherent presentation of M , the monoid presented by Σ .

The existence theorem has been extended by Guiraud and Malbos in [40] into the following result:

Theorem 1.5.2.3 (Extended Existence Theorem). *Let Σ be a convergent 2-polygraph. Then there exists an extension of Σ into an $(\omega, 2)$ -polygraph such that:*

- The $(n + 1)$ -cells of Σ correspond to the n -critical branchings.
- The $(\omega, 2)$ -polygraph Σ forms a polygraphic resolution of M , the monoid presented by Σ .

These existence and detection theorems have slightly different applications. The existence theorem is the one which allowed Squier to prove that all monoids with a finite convergent presentation satisfied his homotopical finiteness condition. Later on the extended one allowed Guiraud and Malbos to refine this condition. Note that the proof of the extended existence theorem is constructive, but the explicit computation of the polygraphic resolution that it provides is often very complicated.

The detection theorem on the other hand is used to prove that a given 3-polygraphs (obtained through other means) forms a coherent presentation of a monoid. The Theorem 3.1.3.5 is another example of a detection theorem used similarly. The main result of Chapter 5 is an extended detection theorem.

1.5.3 Higher-dimensional rewriting in Gray monoids

The difficulty to give a precise statement for an extended detection theorem lies in generalising Equation (1.5.1) to higher dimensions. We show in Chapter 3 that in the next dimension it corresponds to finding, for all critical triple branching, a cell with the shape of a cube, as in equation (3.1.4). In general for an n -fold critical branching, the corresponding cell should have the shape of an n -cube. In Section 5.1.3, this condition is made explicit using the notion of *cubical* ω -groupoid.

To do that, we first study the structure of the local branchings. Let us start from a string rewriting system (E, R) . Then an n -local branching is an n -tuple of rewriting steps that share the same source. We denote the set of n -local branchings $\mathbf{LocBr}(E, R)_n$. Given such an n -tuple $\vec{f} = (f_1, \dots, f_n)$ and $1 \leq i \leq n$, we can define a new $(n-1)$ -critical branching $\partial_i \vec{f} := (f_1; \dots, f_{i-1}, f_{i+1}, \dots, f_n)$. These operations ∂_i define a structure of semi-simplicial set on $\mathbf{LocBr}(\Sigma)$. Defining other operations on local branchings, such as the action of the symmetric group from Section 1.3.4, we finally get in Section 5.1.3 the following result:

Proposition 5.1.3.4. *Let (E, R) be a string rewriting system. The family of local branchings $\mathbf{LocBr}(E, R)$ equipped with the applications ∂_i , ϵ_i and \otimes and the action of the symmetric group forms a simplicial monoid, that is a monoid object in augmented symmetric simplicial sets.*

On the other hand, starting from a cubical ω -groupoid \mathbf{C} , there is a forgetful functor towards symmetric cubical sets by Section 4.4.1, where the symmetries come from the T_i -inverses of the cells. Then from symmetric cubical sets we can forget about the faces ∂_i^+ , the connections Γ_i^+ and the identities ϵ_i . We are left with a structure of an augmented symmetric simplicial set. We prove that this functor is lax monoidal, and so induces a functor V from Gray monoids to simplicial monoids. We are now ready to state our extended detection theorem:

Theorem 5.1.3.8 (Extended Detection Theorem). *Let Σ be a terminating targets-only Gray $(\omega, 1)$ -polygraph, and let M be the monoid presented by Σ . We suppose that there exists a morphism of simplicial monoids*

$$\Phi : \mathbf{LocBr}(\Sigma) \rightarrow V(\Sigma^{G(1)})$$

such that for all $A \in \Sigma$, $\Phi(\mathbf{br}(A)) = A$.

Then the morphism $\Sigma^{G(0)} \rightarrow M$ is an equivalence of ω -groupoids, meaning that Σ is a polygraphic resolution of M .

As with Theorem 1.5.2.2 or 3.1.3.5, we require any critical 3-branching to be associated to a cell of the right shape. The associated cell is given by the map Φ . The analogue of Equation (1.3.2) or (3.1.4) here is hidden in the fact that Φ is a morphism of simplicial monoids, together with the equation $\Phi(\mathbf{br}(A)) = A$. Let us spell out these conditions in low dimensions.

First for a generating 1-cell f , $\mathbf{br}(f)$ is just f , so the condition is that $\Phi(f) = f$. The fact that Φ is a morphism of monoids implies that this is actually true for any *rewriting step* f . In the next dimension, the fact that Σ is targets-only means that any generating 2-cell $A \in \Sigma_2$ can be represented as follows, with f and g *rewriting steps*:

$$\begin{array}{ccc} \begin{array}{ccc} & \xrightarrow{f} & \\ g \downarrow & & \downarrow \\ & A & \\ \downarrow & & \downarrow \\ & \xrightarrow{\quad} & \end{array} & \begin{array}{ccc} & \xrightarrow{f} & \\ g \downarrow & & \downarrow \\ & \mathbf{br}(A) & \\ \downarrow & & \downarrow \\ & \xrightarrow{\quad} & \end{array} & \begin{array}{ccc} & \xrightarrow{f} & \\ g \downarrow & & \downarrow \\ & \Phi(\mathbf{br}(A)) & \\ \downarrow & & \downarrow \\ & \xrightarrow{\quad} & \end{array} \end{array}$$

Then the pair (g, f) forms a local branching, denoted $\mathbf{br}(A)$. The condition $\Phi(\mathbf{br}(A)) = A$ implies that A is the canonical filling associated to (g, f) .

One unexpected condition that appears in Theorem 5.1.3.8 is that we require Φ to be defined on all local branchings. This is to be contrasted to the situation in the detection theorem or in Theorem 3.1.3.5, where we only require conditions on the critical branching. We investigate this discrepancy in Section 5.1.3, and prove the following result:

Theorem 5.3.1.14. *Let (E, R) be a string rewriting system, and suppose that for all $f \in R$, $\mathbf{s}(f) \neq 1$ (which in particular is always true if (E, R) is terminating). Then $\mathbf{LocBr}(E, R)$ is freely generated by any choice of critical branchings up to permutation.*

This implies in particular that defining Φ on the critical branchings is sufficient in order to apply Theorem 5.1.3.8. Using this, we are able in Section 5.3.2 to give an explicit of the reduced standard resolution of a monoid M . The generators of such a resolution were already known [40] (see Theorem 1.5.2.3), but the explicit description of the faces of the generators is new.

Theorem 5.3.2.3. *Let M be a monoid. Let $\mathbf{RStd}(M)$ be the following Gray polygraph:*

- For any $n \geq 0$, $\mathbf{RStd}(M)_n$ consists of $(n+1)$ -tuples (m_1, \dots, m_{n+1}) of elements of $M \setminus \{1\}$, that we denote $(m_1 | \dots | m_{n+1})$.
- The faces are given for $1 \leq i \leq n$ by:

$$\begin{aligned} \partial_i^-(m_1 | \dots | m_{n+1}) &= (m_1 | \dots | m_i) \otimes (m_{i+1} | \dots | m_{n+1}) \\ \partial_i^+(m_1 | \dots | m_{n+1}) &= \begin{cases} (m_1 | \dots | m_i m_{i+1} | m_{i+2} | \dots | m_{n+1}) & m_i m_{i+1} \neq 1 \\ \epsilon_1(m_3 | \dots | m_{n+1}) & i = 1 \text{ and } m_1 m_2 = 1 \\ \Gamma_{i-1}^+(m_1 | \dots | m_{i-1} | m_{i+2} | \dots | m_{n+1}) & 2 \leq i \leq n-1 \text{ and } m_i m_{i+1} = 1 \\ \epsilon_{n-1}(m_1 | \dots | m_{n-1}) & i = n \text{ and } m_n m_{n+1} = 1 \end{cases} \end{aligned}$$

with $\partial_1^+(m_1 | m_2) = 1_{\mathbf{RStd}(M)^{G(0)}}$ if $m_1 m_2 = 1_M$ (the unit of the monoid M).

Then the Gray monoid $\mathbf{RStd}(M)^{G(0)}$ forms a polygraphic resolution of M .

Another application of Theorem 5.1.3.8 and 5.3.1.14 is given in Section 5.3.3, where we give a new proof of the extended existence theorem in our setting.

Theorem 5.3.3.5. *Let (E, R) be a convergent string rewriting system and let M be the monoid presented by (E, R) . There exists an extension of (E, R) into a Gray polygraph Σ such that:*

- The n -cells of Σ_n correspond to the critical branchings
- Σ is a resolution of M (more specifically, Σ satisfies the hypothesis of Theorem 5.1.3.8).

Chapter 2

Classical higher dimensional rewriting

Introduction

In this section we recall some classical notions of higher-dimensional rewriting. We start in Section 2.1 by recalling the definition of ω -category and ω -polygraphs, and more generally of (n, p) -category and (n, p) -polygraph. According to Street in [81], the notion of ω -category was probably first brought up by John Roberts in the late 70s. The earliest published definition can be found in [13]. The notion of 2-polygraph on the other hand was introduced by Street in [78] under the name of computad. It seems that the earliest occurrence of general n -polygraphs in the literature comes [18].

In Section 2.2, we recall some classical definitions and results of higher dimensional rewriting. In our case we need to talk about rewriting in n -categories. See [38] and [39] for references, or [41] for a more gentle introduction to the special case of string rewriting.

Finally, in Section 2.3 we use these techniques to prove coherence theorems for bicategories and pseudofunctors between them. A bicategory being just a monoidal category with many objects, our proof of the coherence theorem for bicategories is a straight adaptation of the proof of the coherence of monoidal categories found in [39]. The case of pseudofunctors is slightly more interesting because we need to find a way to encode the operation of “taking the image through the functor”, but once this is done the same techniques as in the case of monoidal categories can be used.

2.1 Globular (n, p) -categories and polygraphs

This section is divided into two parts: in the first one we introduce ω -categories, while in the second we introduce polygraphs, following their description in [65].

2.1.1 Globular categories

Definition 2.1.1.1. A *n-globular set* (for $n \in \mathbb{N} \cup \{\omega\}$) is the data of a family of sets G_k for $0 \leq k \leq n$ together with source and target maps $s, t : G_{k+1} \rightarrow G_k$ for all $0 \leq k < n$, satisfying the so called *globular relations*:

$$s \circ t = s \circ s \quad t \circ t = t \circ s. \quad (2.1.1)$$

If G is such a globular set, we denote by s_j^k and t_j^k (or simply s_j and t_j) the maps from G_k to G_j such that $s_k^{k+1} = s$, $t_k^{k+1} = t$ and which satisfy the equations:

$$s_i^j \circ t_j^k = s_i^k = s_i^j \circ s_j^k \quad t_i^j \circ t_j^k = s_i^k = t_i^j \circ s_j^k$$

For $f \in G_k$ we call $s_j(f)$ and $t_j(f)$ respectively the k -source and the k -target of f . An element of G_k is called a *k-cell*. Two k -cells $f, g \in G_k$ are said to be j -composable if $t_j(f) = s_j(g)$.

Definition 2.1.1.2. For $n \in \mathbb{N} \cup \{\omega\}$, an *n-category* \mathcal{C} is the data of an n -globular set \mathcal{C} together with, for any $0 \leq k \leq n$ and $0 \leq j < k$, maps \bullet_j associating to any two j -composable k -cells $f, g \in \mathcal{C}_k$ a cell $f \bullet_j g \in \mathcal{C}_k$, and for any k -cell $f \in \mathcal{C}_k$ a $(k+1)$ -cell $1_f \in \mathcal{C}_{k+1}$. This data moreover has to verify the following relations:

- For all j -composable $f, g \in \mathcal{C}_k$, $s(f \bullet_j g) = s(f) \bullet_j s(g)$ and $t(f \bullet_j g) = t(f) \bullet_j t(g)$ if $j \neq k-1$, if $j = k-1$ then $s(f \bullet_j g) = s(f)$, while $t(f \bullet_j g) = t(g)$.
- For all $f \in \mathcal{C}_k$, $s(1_f) = t(1_f) = f$.
- For all j -composable $f, g, h \in \mathcal{C}_k$, $(f \bullet_j g) \bullet_j h = f \bullet_j (g \bullet_j h)$.

- For all $f \in \mathcal{C}_k$, $f \bullet_{k-1} 1_{t(f)} = 1_{s(f)} \bullet_{k-1} f = f$.
- For all $f, f', g, g' \in \mathcal{C}_k$, and $0 \leq i < j < k$, then $(f \bullet_j f') \bullet_i (g \bullet_j g') = (f \bullet_i g) \bullet_j (f' \bullet_i g')$, as soon as the left-hand side is defined.

The relations imply additionally the additional following relations (as soon as they are defined):

$$s_i(f \bullet_j g) = \begin{cases} s_i(f) \bullet_j s_i(g) & i > j \\ s_i(f) & i = j \\ s_i(f) = s_i(g) & i < j \end{cases} \quad t_i(f \bullet_j g) = \begin{cases} t_i(f) \bullet_j t_i(g) & i > j \\ t_i(g) & i = j \\ t_i(f) = t_i(g) & i < j \end{cases}$$

Definition 2.1.1.3. If \mathcal{C} is a 2-category, we denote by \mathcal{C}^{op} the 2-category obtained by reversing the direction of the 1-cells, and by \mathcal{C}^{co} the 2-category obtained by reversing the direction of the 2-cells.

Example 2.1.1.4. Let us explicit the notion of 2-category. The underlying 2-globular set is constituted of three sets \mathcal{C}_0 , \mathcal{C}_1 and \mathcal{C}_2 . A 1-cell f and the 2-cell A are respectively represented as follows:

$$s_0(f) \xrightarrow{f} t_0(f) \quad s_0(A) \begin{array}{c} \xrightarrow{s_1(A)} \\ \Downarrow A \\ \xrightarrow{t_1(A)} \end{array} t_0(A)$$

For any 0-cell $x \in \mathcal{C}_0$ and 1-cell $f \in \mathcal{C}_1$, the cells 1_x and 1_f have the following shape:

$$x \xlongequal{1_x} x \quad s_0(f) \begin{array}{c} \xrightarrow{f} \\ \Downarrow 1_f \\ \xrightarrow{f} \end{array} t_0(f)$$

The composition \bullet_0 associates, to any composable 1-cells $x \xrightarrow{f} y \xrightarrow{g} z$, a

1-cell $x \xrightarrow{f \bullet_0 g} z$. And to any 0-composable 2-cells $x \begin{array}{c} \xrightarrow{f} \\ \Downarrow A \\ \xrightarrow{g} \end{array} y \begin{array}{c} \xrightarrow{f'} \\ \Downarrow A' \\ \xrightarrow{g'} \end{array} z$,

a 2-cell:

$$x \begin{array}{c} \xrightarrow{f \bullet_0 f'} \\ \Downarrow A \bullet_0 A' \\ \xrightarrow{g \bullet_0 g'} \end{array} z$$

Finally, the composition \bullet_1 associates to any 1-composable 2-cells

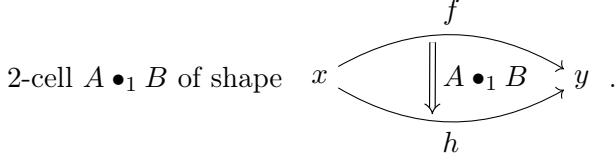
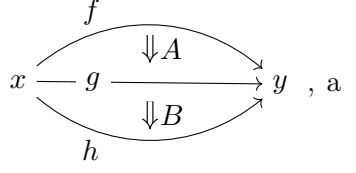

Also, if f is 1-cell and A is a 2-cell then we denote by $f \bullet_0 A$ the composite (when defined) $1_f \star_0 A$, and similarly for $A \star_0 g$ for any 1-cell g . This operation is called *whiskering*. For instance the composite $f \bullet_0 A \bullet_0 g$ is represented as follows:

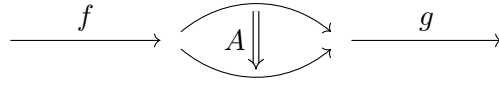

Definition 2.1.1.5. Let \mathcal{C} be an n -category, for $n \in \mathbb{N} \cup \{\omega\}$. For $p \in \mathbb{N} \cup \{\omega\}$, we say that \mathcal{C} is an (n, p) -category if for any $p < k \leq n$, any k -cell has an inverse for composition \bullet_{k-1} . That is for every $A \in \mathcal{C}_k$ there exists $B \in \mathcal{C}_k$ such that $A \bullet_{k-1} B = 1_{s(A)}$ and $B \bullet_{k-1} A = 1_{t(A)}$. In particular for $p \geq n$ an (n, p) -category is just a category, and for $p = 0$ we call an $(n, 0)$ -category an n -groupoid.

Example 2.1.1.6. A 2-category \mathcal{C} is a $(2, 1)$ -category if for any 2-cell $A : f \Rightarrow g \in \mathcal{C}_2$, there exists a 2-cell $A^- : g \Rightarrow f \in \mathcal{C}_2$ such that the following equality holds (together with the one obtained by exchanging the roles of A and A^-):

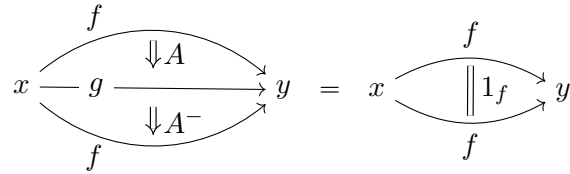

It is a 2-groupoid if moreover for any 1-cell $f : x \rightarrow y$ there exists a 1-cell $f^- : y \rightarrow x$ such that the following equalities hold:

$$x \xrightarrow{f} y \xrightarrow{f^-} x = x \xrightarrow{1_x} x$$

$$y \xrightarrow{f^-} x \xrightarrow{f} y = y \xrightarrow{1_y} y$$

Note that in addition in a 2-groupoid any 2-cell $A : f \Rightarrow g \in \mathcal{C}_2$ admits an inverse $B : f^- \Rightarrow g^-$ for composition \bullet_0 , given by the following composite:

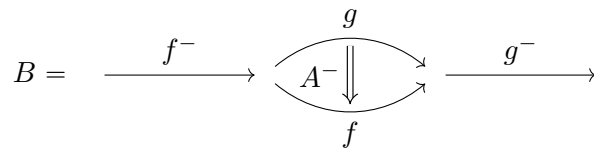

2.1.2 Polygraphs

We recall the definition of polygraphs from [18]. For $n \in \mathbb{N}$, we denote by $n\text{-Cat}$ the category of n -categories and by \mathbf{Graph}_n the category of n -graphs. The category of n -categories equipped with a cellular extension, denoted by $n\text{-Cat}^+$, is the limit of the following diagram:

$$\begin{array}{ccc} n\text{-Cat}^+ & \longrightarrow & \mathbf{Graph}_{n+1} \\ \downarrow & \lrcorner & \downarrow \\ n\text{-Cat} & \longrightarrow & \mathbf{Graph}_n \end{array}$$

where the functor $n\text{-Cat} \rightarrow \mathbf{Graph}_n$ forgets the categorical structure and the functor $\mathbf{Graph}_{n+1} \rightarrow \mathbf{Graph}_n$ deletes the top-dimensional cells.

Hence, an object of $n\text{-Cat}^+$ is a couple (\mathcal{C}, G) where \mathcal{C} is an n -category and G is a graph $\mathcal{C}_n \xleftarrow[\text{t}]{\text{s}} \mathcal{C}_{n+1}$, such that for any $u, v \in \mathcal{C}_{n+1}$, the following equations are verified:

$$s(s(u)) = s(t(u)) \quad t(s(u)) = t(t(u))$$

Let \mathcal{R}_n be the functor from $(n+1)\text{-Cat}$ to $n\text{-Cat}^+$ that sends an $(n+1)$ -category \mathcal{C} on the couple $(\mathcal{C}_n, \mathcal{C}_n \xleftarrow{\quad} \mathcal{C}_{n+1})$. This functor admits a left-adjoint $\mathcal{L}_n : n\text{-Cat}^+ \rightarrow (n+1)\text{-Cat}$ (see [66]).

We now define by induction on n the category \mathbf{Pol}_n of n -polygraphs together with a functor $\mathcal{Q}_n : \mathbf{Pol}_n \rightarrow n\text{-Cat}$.

- The category \mathbf{Pol}_0 is the category of sets, and \mathcal{Q}_0 is the identity functor.
- Assume $\mathcal{Q}_n : \mathbf{Pol}_n \rightarrow n\text{-Cat}$ is defined. Then \mathbf{Pol}_{n+1} is the limit of the following diagram:

$$\begin{array}{ccc} \mathbf{Pol}_{n+1} & \longrightarrow & n\text{-Cat}^+ \\ \downarrow & \lrcorner & \downarrow \\ \mathbf{Pol}_n & \xrightarrow[\mathcal{Q}_n]{} & n\text{-Cat}, \end{array}$$

and \mathcal{Q}_{n+1} is the composite

$$\mathbf{Pol}_{n+1} \longrightarrow n\text{-Cat}^+ \xrightarrow{\mathcal{L}_n} (n+1)\text{-Cat}$$

Definition 2.1.2.1. Given an n -polygraph Σ , the n -category $\mathcal{Q}_n(\Sigma)$ is denoted by Σ^* and is called *the free n -category generated by Σ* .

Definition 2.1.2.2. Let \mathcal{C} be an n -category, and $0 \leq i < n$ and $A \in \mathcal{C}_{i+1}$. If it exists, we denote by A^{-1} the inverse of A for the i -composition.

We denote by $n\text{-Cat}^{(k)}$ the full subcategory of $n\text{-Cat}$ whose objects are the (n, k) -categories.

In particular $n\text{-Cat}^{(0)}$ is the category of n -groupoids, and $n\text{-Cat}^{(n)} = n\text{-Cat}$.

The functor \mathcal{R}_n restricts to a functor $\mathcal{R}_n^{(n)}$ from $(n+1)\text{-Cat}^{(n)}$ to $n\text{-Cat}^+$. Once again this functor admits a left-adjoint $\mathcal{L}_n^{(n)} : n\text{-Cat}^+ \rightarrow (n+1)\text{-Cat}^{(n)}$. We define categories $\mathbf{Pol}_n^{(k)}$ of (n, k) -polygraphs and functors $\mathcal{Q}_n^{(k)} : \mathbf{Pol}_n^{(k)} \rightarrow n\text{-Cat}^{(k)}$ in a similar way to \mathbf{Pol}_n and \mathcal{Q}_n . See 2.2.3 in [40] for an explicit description of this construction.

Definition 2.1.2.3. Given an (n, k) -polygraph Σ , the (n, k) -category $\mathcal{Q}_n^{(k)}(\Sigma)$ is denoted by $\Sigma^{*(k)}$ and is called *the free (n, k) -category generated by Σ* . For $j \leq n$, we denote by $\Sigma_j^{*(k)}$ both the j -cells of $\Sigma^{*(k)}$ and the (j, k) -category generated by Σ . Hence, an (n, k) -polygraph Σ consists of the following data:

$$\begin{array}{cccccccccccc}
 \Sigma_0 & & \Sigma_1 & & \Sigma_2 & & (\dots) & & \Sigma_k & & \Sigma_{k+1} & & (\dots) & & \Sigma_n \\
 \parallel & \swarrow & \downarrow & \swarrow & \downarrow & \swarrow & & & \swarrow & \downarrow & \swarrow & \downarrow & \swarrow & & \swarrow \\
 \Sigma_0 & \xleftarrow{\quad} & \Sigma_1^* & \xleftarrow{\quad} & \Sigma_2^* & \xleftarrow{\quad} & (\dots) & \xleftarrow{\quad} & \Sigma_k^* & \xleftarrow{\quad} & \Sigma_{k+1}^{*(k)} & \xleftarrow{\quad} & (\dots) & &
 \end{array}$$

Remark 2.1.2.4. Let n, j and k be integers, with $j \leq k \leq n$. Since an (n, j) -category is also an (n, k) -category, an (n, k) -polygraph gives rise to an (n, j) -polygraph. In particular for $n = k = 1$ and $j = 0$ we recover that a monoid presentation gives rise to a group presentation.

In particular, if Σ is an (n, k) -polygraph, we denote by $\Sigma^{*(j)}$ the (n, j) -category it generates.

Definition 2.1.2.5. Let \mathcal{C} be an $(n+1, k)$ -category. We denote by $\bar{\mathcal{C}}$ the (n, k) -category $\mathcal{C}_n/\mathcal{C}_{n+1}$.

Let Σ be an $(n+1, k)$ -polygraph. We denote by $\bar{\Sigma}$ the (n, k) -category $\Sigma^{*(k)}$ and call it the (n, k) -category presented by Σ .

2.2 Higher-dimensional rewriting

In this section we recall the notions of termination (Section 2.2.1), confluence (Section 2.2.2) and coherence (Section 2.2.3) of an n -category. Since this n will vary throughout Chapter 3, we talk instead of n -confluence, n -termination and n -confluence. Finally, we state Squier's theorem, under its more general form proved by Guiraud and Malbos in [38].

2.2.1 Termination

Definition 2.2.1.1. Let Σ be an n -polygraph. For $0 < k \leq n$, the binary relation \rightarrow_k^* defined by $u \rightarrow_k^* v$ if there exists $f : u \rightarrow v$ in Σ_k^* is a preorder on Σ_{k-1}^* (transitivity is given by composition, and reflexivity by the units). We say that the n -polygraph Σ is k -terminating if \rightarrow_k^* is a well-founded ordering. We denote by \rightarrow_k^+ the strict ordering associated to \rightarrow_k^* .

We recall Theorem 4.2.1 from [38], which we will use in order to show the 3-termination of some polygraphs.

Definition 2.2.1.2. Let \mathbf{sOrd} be the 2-category with one object, whose 1-cells are partially ordered sets, whose 2-cells are monotonic functions and whose 0-composition is the cartesian product.

Definition 2.2.1.3. Let \mathcal{C} be a 2-category, $X : \mathcal{C}_2 \rightarrow \mathbf{sOrd}$ and $Y : \mathcal{C}_2^{\text{co}} \rightarrow \mathbf{sOrd}$ two 2-functors, and M a commutative monoid. An (X, Y, M) -derivation on \mathcal{C} is given by, for every 2-cell $f \in \mathcal{C}_2$, an application

$$d(f) : X(\text{s}(f)) \times Y(\text{t}(f)) \rightarrow M,$$

such that for every 2-cells $f_1, f_2 \in \mathcal{C}_2$, every x, y, z and t respectively in $X(\text{s}(f_1))$, $Y(\text{t}(f_1))$, $X(\text{s}(f_2))$ and $Y(\text{t}(f_2))$, the following equalities hold:

$$d(f_1 \bullet_1 f_2)[x, t] = d(f_1)[x, Y(f_2)[y]] + d(f_2)[X(f_1)[x], y]$$

$$d(f_1 \bullet_0 f_2)[(x, z), (y, t)] = d(f_1)[x, y] + d(f_2)[z, t].$$

In order to show the 3-termination of some polygraphs, we are going to use the following result (Theorem 4.2.1 from [38]).

Theorem 2.2.1.4. Let Σ be an n -polygraph, $X : \Sigma_2^* \rightarrow \mathbf{sOrd}$ and $Y : (\Sigma_2^*)^{\text{co}} \rightarrow \mathbf{sOrd}$ two 2-functors, and M be a commutative monoid equipped with a well-founded ordering \geq , and whose addition is strictly monotonous in both arguments.

Suppose that for every 3-cell $A \in \Sigma_3$, the following inequalities hold:

$$X(\text{s}(A)) \geq X(\text{t}(A)) \quad Y(\text{s}(A)) \geq Y(\text{t}(A)) \quad d(\text{s}(A)) > d(\text{t}(A)).$$

Then the n -polygraph Σ is 3-terminating.

2.2.2 Branchings and Confluence

Definition 2.2.2.1. Let Σ be an n -polygraph. A k -fold branching of Σ is a k -tuple (f_1, f_2, \dots, f_k) of n -cells in Σ^* such that every f_i has the same source u , which is called the source of the branching.

The symmetric group S_k acts on the set of all k -fold branchings of Σ . The equivalence class of a branching (f_1, f_2, \dots, f_k) under this action is denoted by $[f_1, f_2, \dots, f_k]$. Such an equivalence class is called a k -fold symmetrical branching, and (f_1, f_2, \dots, f_k) is called a representative of $[f_1, f_2, \dots, f_k]$.

Definition 2.2.2.2. Let Σ be an n -polygraph. We denote by \mathbb{N} the n -category with exactly one k -cell for every $k < n$, whose n -cells are the natural numbers and whose compositions are all given by addition.

We define an application $l : \Sigma^* \rightarrow \mathbb{N}$ by setting $l(f) = 1$ for every $f \in \Sigma_n$. For $f \in \Sigma_n^*$, we call $l(f)$ the *length* of a f .

An n -cell of length 1 in Σ_n^* is also called a *rewriting step*.

Definition 2.2.2.3. Let Σ be an n -polygraph. A k -fold local branching of Σ is a k -fold branching (f_1, f_2, \dots, f_k) of Σ where every f_i is a rewriting step.

A k -fold local branching (f_1, \dots, f_k) of source u is a *strict aspherical branching* if there exists an integer i such that $f_i = f_{i+1}$. We say that it is an *aspherical branching* if it is in the equivalence class of a strict aspherical branching.

A k -fold local branching (f_1, \dots, f_k) is a *strict Peiffer branching* if it is not aspherical and there exist $v_1, v_2 \in \Sigma_{n-1}^*$ such that $u = v_1 \bullet_i v_2$, an integer $m < n$ and $f'_1, \dots, f'_k \in \Sigma_n^*$ such that for every $j \leq m$, $f_j = f'_j \bullet_i v_2$ and for every $j > m$, $f_j = v_1 \bullet_i f'_j$. It is a *Peiffer branching* if it is in the equivalence class of a strict Peiffer branching.

A local branching that is neither aspherical nor Peiffer is *overlapping*.

Given an n -polygraph Σ , one defines an order \subseteq on k -fold local branchings by saying that $(f_1, \dots, f_k) \subseteq (u \bullet_i f_1 \bullet_i v, \dots, u \bullet_i f_k \bullet_i v)$ for every $u, v \in \Sigma_{n-1}^*$ and every k -fold local branching (f_1, \dots, f_k) .

Definition 2.2.2.4. An overlapping branching that is minimal for \subseteq is a *critical branching*.

A 2-fold (resp. 3-fold) critical branching is also called a *critical pair* (resp. *critical triple*).

Definition 2.2.2.5. Let Σ be an n -polygraph. A 2-fold branching (f, g) is *confluent* if there are $f', g' \in \Sigma_n^*$ of the following shape:

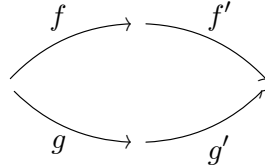

Definition 2.2.2.6. An n -polygraph Σ is k -confluent if every 2-fold branching of Σ_k is confluent.

Definition 2.2.2.7. An n -polygraph is k -convergent if it is k -terminating and k -confluent.

The following two propositions are proven in [38].

Proposition 2.2.2.8. *Let Σ be an n -terminating n -polygraph. It is n -confluent if and only if every 2-fold critical branching is confluent.*

Proposition 2.2.2.9. *Let Σ be a k -convergent n -polygraph. For every $u \in \Sigma_{k-1}^*$, there exists a unique $v \in \Sigma_{k-1}^*$ such that $u \rightarrow_k^* v$ and v is minimal for \rightarrow_k^* .*

Definition 2.2.2.10. Let Σ be an n -polygraph. A *normal form* for Σ is an $(n-1)$ -cell minimal for \rightarrow_n^* .

If Σ is n -convergent, for every $u \in \Sigma_{n-1}^*$, the unique normal form v such that $u \rightarrow_n^* v$ is denoted by \hat{u} and is called *the normal form of u* .

2.2.3 Coherence

Definition 2.2.3.1. Two k -cells are *parallel* if they have the same source and the same target.

An $(n + 1)$ -category \mathcal{C} is *n -coherent* if, for each pair (f, g) of parallel n -cells in \mathcal{C}_n , there exists an $(n + 1)$ -cell $A : f \rightarrow g$ in \mathcal{C}_{n+1} .

Definition 2.2.3.2. Let Σ be an $(n + 1)$ -polygraph, and (f, g) be a local branching of Σ_n . A *filling* of (f, g) is an $(n + 1)$ -cell $A \in \Sigma_{n+1}^{*(n)}$ of the shape:

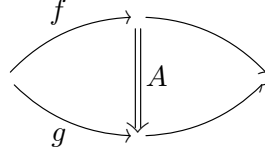

Definition 2.2.3.3. An $(n + 1)$ -polygraph Σ satisfies the *n -Squier condition* if:

- it is n -convergent,
- there is a bijective application from Σ_{n+1} to the set of all critical pairs of Σ_n that associates to every $A \in \Sigma_{n+1}$, a critical pair b of Σ_n such that A is a filling of a representative of b .

The following Theorem is due to Squier for $n = 2$ [75] and was extended to any integer $n \geq 2$ by Guiraud and Malbos [38].

Theorem 2.2.3.4. *Let Σ be an $(n + 1)$ -polygraph satisfying the n -Squier condition. Then the free $(n + 1, n - 1)$ -category $\Sigma^{*(n-1)}$ is n -coherent.*

In the proof of this Theorem appears the following result (Lemma 4.3.3 in [38]).

Proposition 2.2.3.5. *Let Σ be an $(n + 1)$ -polygraph satisfying the n -Squier condition.*

For every parallel n -cells $f, g \in \Sigma_n^$ whose target is a normal form, there exists an $(n + 1)$ -cell $A : f \rightarrow g$ in $\Sigma_{n+1}^{*(n)}$.*

Let us compare those two last results. Let Σ be an $(n + 1)$ -polygraph satisfying the n -Squier condition, and let $f, g \in \Sigma_n^*$ be two parallel n -cells whose target is a normal form. According to Theorem 2.2.3.4, there exists an $(n + 1)$ -cell $A : f \rightarrow g$ in the free $(n + 1, n - 1)$ -category $\Sigma_{n+1}^{*(n-1)}$. Proposition 2.2.3.5 shows that such an A can be chosen in the free $(n + 1, n)$ -category $\Sigma_{n+1}^{*(n)}$, where the n -cells are not invertible. Hence, for cells $f, g \in \Sigma_n^*$ whose target is a normal form, Proposition 2.2.3.5 is more precise than Theorem 2.2.3.4.

2.3 Application to the coherence of bicategories and pseudofunctors

We now study the coherence problem successively for bicategories and pseudofunctors. In Section 2.3.1, we start by recalling the usual definition of bicategories (see [7]). We then give an alternative description of bicategories in terms of algebras over a certain 4-polygraph $\mathbf{BiCat}[\mathbf{C}]$, and show that the two definitions coincide. The coherence problem for bicategories is now reduced to showing the 3-coherence of $\mathbf{BiCat}[\mathbf{C}]$, and we use the techniques introduced in the previous section (especially Theorems 2.2.1.4 and 2.2.3.4) to conclude. In Section 2.3.2, we apply the same reasoning to pseudofunctors.

2.3.1 Coherence for bicategories

Let \mathbf{Cat} be the category of (small) categories. We denote by \top the terminal category in \mathbf{Cat} . Let \mathbf{sCat} be the 3-category with one 0-cell, (small) categories as 1-cells, functors as 2-cells, and natural transformations as 3-cells, where 0-composition is given by the cartesian product, 1-composition by functor composition, and 2-composition by composition of natural transformations.

Definition 2.3.1.1. A bicategory \mathcal{B} is given by:

- A set \mathcal{B}_0 .
- For every $a, b \in \mathcal{B}_0$, a category $\mathcal{B}(a, b)$. The objects and arrows of $\mathcal{B}(a, b)$ are respectively called the 1-cells \mathcal{B} and 2-cells of \mathcal{B} .
- For every $a, b, c \in \mathcal{B}_0$, a functor $\bullet_{a,b,c} : \mathcal{B}(a, b) \times \mathcal{B}(b, c) \rightarrow \mathcal{B}(a, c)$.
- For every $a \in \mathcal{B}_0$, a functor $I_a : \top \rightarrow \mathcal{B}(a, a)$, that is to say a 1-cell $I_a : a \rightarrow a$.
- For every $a, b, c, d \in \mathcal{B}_0$, a natural isomorphism $\alpha_{a,b,c,d}$:

$$\begin{array}{ccc}
 \mathcal{B}(a, b) \times \mathcal{B}(b, c) \times \mathcal{B}(c, d) & \xrightarrow{\mathcal{B}(a, b) \times \bullet_{b,c,d}} & \mathcal{B}(a, b) \times \mathcal{B}(b, d) \\
 \bullet_{a,b,c} \times \mathcal{B}(c, d) \downarrow & \nearrow \alpha_{a,b,c,d} & \downarrow \bullet_{a,b,d} \\
 \mathcal{B}(a, c) \times \mathcal{B}(c, d) & \xrightarrow{\bullet_{a,c,d}} & \mathcal{B}(a, d)
 \end{array}$$

of components $\alpha_{f,g,h} : (f \bullet g) \bullet h \Rightarrow f \bullet (g \bullet h)$, for every triple $(f, g, h) \in \mathcal{B}(a, b) \times \mathcal{B}(b, c) \times \mathcal{B}(c, d)$.

- For every $a, b \in \mathcal{B}_0$, natural isomorphisms $R_{a,b}$ and $L_{a,b}$:

$$\begin{array}{ccc}
 \mathcal{B}(a, b) & \xrightarrow{\mathcal{B}(a, b) \times I_b} & \mathcal{B}(a, b) \times \mathcal{B}(b, b) \\
 \downarrow & \nearrow R_{a,b} & \downarrow \bullet_{a,b,b} \\
 I_a \times \mathcal{B}(a, b) & & \\
 \downarrow & \nearrow L_{a,b} & \\
 \mathcal{B}(a, a) \times \mathcal{B}(a, b) & \xrightarrow{\bullet_{a,a,b}} & \mathcal{B}(a, b)
 \end{array}$$

of components $L_f : I_a \bullet f \Rightarrow f$ and $R_f : f \bullet I_b \Rightarrow f$ for every 1-cell $f \in \mathcal{B}(a, b)$.

This data must also satisfy the following axioms:

- For every composable 2-cells f, g, h, i in \mathcal{B} :

$$\begin{array}{ccc}
 & ((f \bullet g) \bullet h) \bullet i & \\
 \alpha_{f \bullet g, h, i} \swarrow & & \searrow \alpha_{f, g, h \bullet i} \\
 (f \bullet g) \bullet (h \bullet i) & = & (f \bullet (g \bullet h)) \bullet i \\
 \alpha_{f, g, h \bullet i} \searrow & & \downarrow \alpha_{f, g \bullet h, i} \\
 & f \bullet (g \bullet (h \bullet i)) & \\
 & \swarrow f \bullet \alpha_{g, h, i} & \\
 & f \bullet (g \bullet (h \bullet i)) &
 \end{array} \tag{2.3.1}$$

- For every couple $(f, g) \in \mathcal{B}(a, b) \times \mathcal{B}(b, c)$:

$$\begin{array}{ccc}
 & (f \bullet I_b) \bullet g & \\
 \alpha_{f, I_b, g} \swarrow & & \searrow R_f \bullet g \\
 f \bullet (I_b \bullet g) & = & f \bullet g \\
 \xrightarrow{f \bullet L_g} & &
 \end{array} \tag{2.3.2}$$

Definition 2.3.1.2. Let \mathbf{C} be a set. Let us describe dimension by dimension a 4-polygraph $\mathbf{BiCat}[\mathbf{C}]$, so that bicategories correspond to algebras on $\mathbf{BiCat}[\mathbf{C}]$, that is to 4-functors from $\mathbf{BiCat}[\mathbf{C}]$ to \mathbf{sCat} (see Proposition 2.3.1.4).

Dimension 0: Let $\mathbf{BiCat}[\mathbf{C}]_0$ be the set \mathbf{C} .

Dimension 1: The set $\mathbf{BiCat}[\mathbf{C}]_1$ contains, for every $a, b \in \mathbf{C}$, a 1-cell $a|_b : a \rightarrow b$.

Dimension 2: The set $\mathbf{BiCat}[\mathbf{C}]_2$ contains the following 2-cells:

- For every $a, b, c \in \mathbf{C}$, a 2-cell $\nabla_{a,b,c} : a|_b|_c \Rightarrow a|_c$.
- For every $a \in \mathbf{C}$, a 2-cell $\varphi_a : 1_a \Rightarrow a|_a$.

Note that the indices are redundant with the source of a generating 2-cell. In what follows, we will therefore omit them when the context is clear. For example, the 2-cell ∇ of source $a|_b|_c|_d$ designates the composite $(a|_b \nabla_{b,c,d}) \bullet_1 \nabla_{a,b,d}$. We will use the same notation for higher-dimensional cells.

Dimension 3: The set $\mathbf{BiCat}[\mathbf{C}]_3$ contains the following 3-cells:

- For every $a, b, c, d \in \mathbf{C}$, a 3-cell $\nabla_{a,b,c,d} : \nabla_{a,b,c} \Rightarrow \nabla_{a,b,d}$ of 1-source $a|_b|_c|_d$.
- For every $a, b \in \mathbf{C}$, 3-cells $\natural_{a,b} : \varphi_a \Rightarrow |$ and $\flat_{a,b} : \nabla_{a,b} \Rightarrow |$ of 1-source $a|_b$.

Dimension 4: The set $\mathbf{BiCat}[\mathbf{C}]_4$ contains the following 4-cells:

- For every $a, b, c, d, e \in \mathbf{C}$, a 4-cell $\alpha_{a,b,c,d,e}$ of 1-source $ab|c|d|e$.

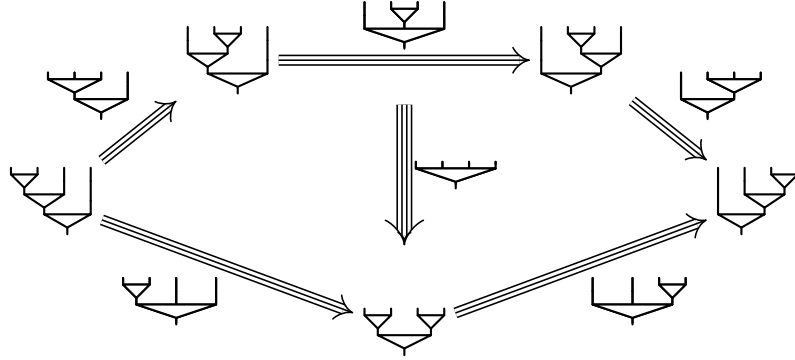

- For every $a, b, c \in \mathbf{C}$, a 4-cell $\varphi_{a,b,c}$ of 1-source $a|b|c$.

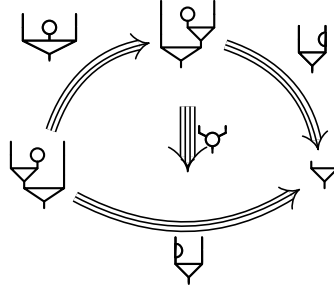

Definition 2.3.1.3. We denote by $\text{Alg}(\mathbf{BiCat})$ the set of all couples (\mathbf{C}, Φ) :

- where \mathbf{C} is a set,
- where Φ is a functor from $\overline{\mathbf{BiCat}[\mathbf{C}]}$ to \mathbf{sCat} .

Proposition 2.3.1.4. *There is a one-to-one correspondence between (small) bicategories and $\text{Alg}(\mathbf{BiCat})$.*

Proof. The correspondence between a bicategory \mathcal{B} and an algebra (\mathbf{C}, Φ) over \mathbf{BiCat} is given by:

- At the level of sets: $\mathbf{C} = \mathcal{B}_0$.
- For every $a, b \in \mathcal{B}_0$, $\Phi(a|b) = \mathcal{B}(a, b)$.
- For every $a, b, c \in \mathcal{B}_0$, $\Phi(\nabla_{a,b,c}) = \bullet_{a,b,c}$.
- For every $a \in \mathcal{B}_0$, $\Phi(\varphi_a) = I_a$.
- For every $a, b, c, d \in \mathcal{B}_0$, $\Phi(\alpha_{a,b,c,d}) = \alpha_{a,b,c,d}$.
- For every $a, b \in \mathcal{B}_0$, $\Phi(\mathfrak{p}_{a,b}) = R_{a,b}$ and $\Phi(\mathfrak{d}_{a,b}) = L_{a,b}$.
- The axioms that a bicategory must satisfy correspond to the fact that Φ is compatible with the quotient by the 4-cells $\alpha_{a,b,c,d}$ and $\varphi_{a,b,c}$.

Bicategory		$Alg(\mathbf{BiCat})$	
Sets	\mathcal{B}_0	\mathbf{C}	0-cells
Categories	$\mathcal{B}(_, _)$	\downarrow	1-cells
Functors	\bullet, I	∇, \wp	2-cells
Natural transformations	α, L, R	∇, \wp, \wp	3-cells
Equalities	(2.3.1) (2.3.2)	∇, \wp	4-cells

Table 2.1: Correspondence for bicategories

This correspondence between the structures of bicategory and of algebra over \mathbf{BiCat} is summed up by Table 2.1. □

We are going to show the coherence theorem for bicategories, using Theorem 2.2.3.4.

Proposition 2.3.1.5. *For every set \mathbf{C} , the 4-polygraph $\mathbf{BiCat}[\mathbf{C}]$ 3-terminates.*

Proof. In order to apply Theorem 2.2.1.4 we construct two functors $X_{\mathbf{C}} : \mathbf{BiCat}[\mathbf{C}]_2^* \rightarrow \mathbf{sOrd}$ and $Y_{\mathbf{C}} : (\mathbf{BiCat}[\mathbf{C}]_2^*)^{\text{co}} \rightarrow \mathbf{sOrd}$ by setting, for every $a, b \in \mathbf{C}$:

$$X_{\mathbf{C}}(ab) = Y_{\mathbf{C}}(ab) = \mathbb{N}^*$$

and, for every $i, j \in \mathbb{N}^*$:

$$X_{\mathbf{C}}(\nabla)[i, j] = i + j, \quad X_{\mathbf{C}}(\wp) = 1, \quad Y_{\mathbf{C}}(\nabla)[i] = (i, i).$$

We now define an $(X_{\mathbf{C}}, Y_{\mathbf{C}}, \mathbb{N})$ -derivation $d_{\mathbf{C}}$ on $\mathbf{BiCat}[\mathbf{C}]_2^*$ by setting, for every $i, j, k \in \mathbb{N}^*$:

$$d_{\mathbf{C}}(\nabla)[i, j, k] = i + k + 1, \quad d_{\mathbf{C}}(\wp)[i] = i,$$

It remains to show that the required inequalities are satisfied. Concerning $X_{\mathbf{C}}$ and $Y_{\mathbf{C}}$, we have for every $i, j, k \in \mathbb{N}^*$:

$$X_{\mathbf{C}}(\nabla \nabla)[i, j, k] = i + j + k \geq i + j + k = X_{\mathbf{C}}(\nabla \wp)[i, j, k]$$

$$X_{\mathbf{C}}(\wp \nabla)[i] = i + 1 \geq i = X_{\mathbf{C}}(\nabla \nabla)[i] \quad X_{\mathbf{C}}(\wp \wp)[i] = i + 1 \geq i = X_{\mathbf{C}}(\nabla \nabla)[i]$$

$$Y_{\mathbf{C}}(\nabla \nabla)[i] = (i, i, i) \geq (i, i, i) = Y_{\mathbf{C}}(\nabla \wp)[i]$$

$$Y_{\mathbf{C}}(\wp \nabla)[i] = i \geq i = Y_{\mathbf{C}}(\nabla \nabla)[i] \quad Y_{\mathbf{C}}(\wp \wp)[i] = i \geq i = Y_{\mathbf{C}}(\nabla \nabla)[i].$$

Concerning $d_{\mathbf{C}}$, we have for every $i, j, k, l \in \mathbb{N}^*$:

$$d_{\mathbf{C}}(\nabla \nabla \nabla)[i, j, k, l] = 2i + j + 2l + 2 > i + j + 2l + 2 = d_{\mathbf{C}}(\nabla \wp \nabla)[i, j, k, l]$$

$$d_{\mathbf{C}}(\wp \nabla \nabla)[i, j] = 2j + 2 > 0 = d_{\mathbf{C}}(\nabla \nabla \nabla)[i, j] \quad d_{\mathbf{C}}(\wp \wp \nabla)[i, j] = i + 2j + 1 > 0 = d_{\mathbf{C}}(\nabla \nabla \nabla)[i, j].$$

□

The following Theorem is a rephrasing of Mac Lane's coherence theorem [61] in our setting.

Theorem 2.3.1.6. *Let \mathbf{C} be a set.*

The 4-polygraph $\mathbf{BiCat}[\mathbf{C}]$ is 3-convergent and the free $(4,2)$ -category $\mathbf{BiCat}[\mathbf{C}]^{(2)}$ is 3-coherent.*

Proof. We already know that $\mathbf{BiCat}[\mathbf{C}]$ is 3-terminating. Using Proposition 2.2.2.8 and Theorem 2.2.3.4, it remains to show that every critical pair admits a filling.

There are five families of critical pairs, of sources:

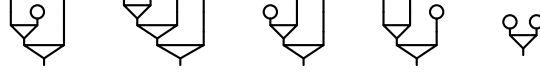

The first two families are filled by the 4-cells \wp and \wp' , whereas the last three are filled by 4-cells $\omega_i \in \mathbf{BiCat}[\mathbf{C}]_4^{*(2)}$, which are constructed in a similar fashion as in the case of monoidal categories (see Proposition 3.5 in [39]). \square

2.3.2 Coherence for pseudofunctors

Definition 2.3.2.1. A pseudofunctor F is given by:

- Two bicategories \mathcal{B} and \mathcal{B}' .
- A function $F_0 : \mathcal{B}_0 \rightarrow \mathcal{B}'_0$.
- For every $a, b \in \mathcal{B}_0$, a functor $F_{a,b} : \mathcal{B}(a, b) \rightarrow \mathcal{B}'(F_0(a), F_0(b))$.
- For every $a, b, c \in \mathcal{B}_0$, a natural isomorphism $\phi_{a,b,c}$:

$$\begin{array}{ccc}
 \mathcal{B}(a, b) \times \mathcal{B}(b, c) & \xrightarrow{\bullet_{a,b,c}} & \mathcal{B}(a, c) \\
 \downarrow F_{a,b} \times F_{b,c} & \swarrow \phi_{a,b,c} & \downarrow F_{a,c} \\
 \mathcal{B}'(F_0(a), F_0(b)) \times \mathcal{B}'(F_0(b), F_0(c)) & \xrightarrow{\bullet'_{F_0(a), F_0(b), F_0(c)}} & \mathcal{B}'(F_0(a), F_0(c))
 \end{array}$$

of components $\phi_{f,g} : F(f \bullet g) \Rightarrow F(f) \bullet' F(g)$, for every couple $(f, g) \in \mathcal{B}(a, b) \times \mathcal{B}(b, c)$.

- For every $a \in \mathcal{B}_0$, a natural isomorphism ψ_a :

$$\begin{array}{ccc}
 \top & \xrightarrow{I_a} & \mathcal{B}(a, a) \\
 \parallel & \swarrow \psi_a & \downarrow F_{a,a} \\
 \top & \xrightarrow{I'_{F_0(a), F_0(a)}} & \mathcal{B}'(F_0(a), F_0(a))
 \end{array}$$

of components $\psi_a : F(I_a) \Rightarrow I'_{F_0(a)}$, for every $a \in \mathcal{B}_0$

This data must satisfy the following axioms:

- For every composable 1-cells f, g and h in \mathcal{B} :

$$\begin{array}{ccc}
& F((f \bullet g) \bullet h) & \\
\begin{array}{c} \xleftarrow{F(\alpha_{f,g,h})} \\ \xrightarrow{\phi_{f \bullet g, h}} \end{array} & & \begin{array}{c} \xrightarrow{\phi_{f \bullet g, h}} \\ \xleftarrow{\phi_{f, g} \bullet' F(h)} \end{array} \\
F(f \bullet (g \bullet h)) & & F(f \bullet g) \bullet' F(h) \\
\downarrow \phi_{f, g \bullet h} & = & \downarrow \phi_{f, g} \bullet' F(h) \\
F(f) \bullet' F(g \bullet h) & & (F(f) \bullet' F(g)) \bullet' F(h) \\
\begin{array}{c} \xrightarrow{F(f) \bullet' \phi_{g, f}} \\ \xleftarrow{\alpha'_{F(f), F(g), F(h)}} \end{array} & & \begin{array}{c} \xrightarrow{F(f) \bullet' \phi_{g, f}} \\ \xleftarrow{\alpha'_{F(f), F(g), F(h)}} \end{array} \\
F(f) \bullet' (F(g) \bullet' F(h)) & & F(f) \bullet' (F(g) \bullet' F(h))
\end{array} \quad (2.3.3)$$

- For every 1-cell $f : a \rightarrow b$ in \mathcal{B} :

$$\begin{array}{ccc}
& F(I_a) \bullet' F(f) \xrightarrow{\psi_a \bullet' F(f)} I'_{F_0(a)} \bullet' F(f) & \\
\begin{array}{c} \xrightarrow{\phi_{I_a, f}} \\ \xrightarrow{L'_F(f)} \end{array} & & \\
F(I_a \bullet f) & \xrightarrow{F(L_f)} & F(f)
\end{array} \quad (2.3.4)$$

- For every 1-cell $f : a \rightarrow b$ in \mathcal{B} :

$$\begin{array}{ccc}
& F(f) \bullet' F(I_b) \xrightarrow{F(f) \bullet' \psi_b} F(f) \bullet' I'_{F_0(b)} & \\
\begin{array}{c} \xrightarrow{\phi_{f, I_b}} \\ \xrightarrow{R'_F(f)} \end{array} & & \\
F(f \bullet I_b) & \xrightarrow{F(R_f)} & F(f)
\end{array} \quad (2.3.5)$$

Definition 2.3.2.2. Let \mathbf{C} and \mathbf{D} be sets, and \mathbf{f} an application from \mathbf{C} to \mathbf{D} . Let us describe dimension by dimension a 4-polygraph $\mathbf{PFonct}[\mathbf{f}]$. We will prove in Proposition 2.3.2.5 that pseudofunctors correspond to algebras over $\mathbf{PFonct}[\mathbf{f}]$.

The polygraph $\mathbf{PFonct}[\mathbf{f}]$ contains the union of:

- the polygraph $\mathbf{BiCat}[\mathbf{C}]$, whose cells are denoted by $\nabla, \varphi, \blacktriangledown, \blacktriangleright, \blacktriangleleft$ and \blacktriangleright' , defined as in Definition 2.3.1.2,
- the polygraph $\mathbf{BiCat}[\mathbf{D}]$, whose cells are denoted by $\nabla, \bullet, \blacktriangledown, \blacktriangleright, \blacktriangleleft$ and \blacktriangleright' , defined as in Definition 2.3.1.2,

together with the following cells:

Dimension 1: For every $a \in \mathbf{C}$, the set $\mathbf{PFonct}[\mathbf{f}]_1$ contains a 1-cell $a_{\mathbf{f}(a)} : a \rightarrow \mathbf{f}(a)$.

Dimension 2: For every $a, b \in \mathbf{C}$, the set $\mathbf{PFonct}[\mathbf{f}]_2$ contains a 2-cell $\blacktriangleright'_{a,b} : a_{\mathbf{f}(b)} \Rightarrow a_{\mathbf{f}(a)} \mathbf{f}(b)$.

Dimension 3: The set $\mathbf{PFonct}[\mathbf{f}]_3$ contains the following 3-cells:

- For every $a, b, c \in \mathbf{C}$, a 3-cell $\text{red_cup}_{a,b,c} : \text{red_cup} \Rightarrow \text{red_cup}$ of 1-source $a|b|c|f(c)$.
- For every $a \in \mathbf{C}$, a 3-cell $\text{red_dot}_a : \text{red_dot} \Rightarrow \text{red_dot}$ of 1-source $a|f(a)$.

Dimension 4: The $\mathbf{PFonct}[\mathbf{f}]_4$ contains the following 4-cells:

- For every $a, b, c, d \in \mathbf{C}$, a 4-cell $\text{red_cup}_{a,b,c,d}$ of 1-source $a|b|c|d|f(d)$

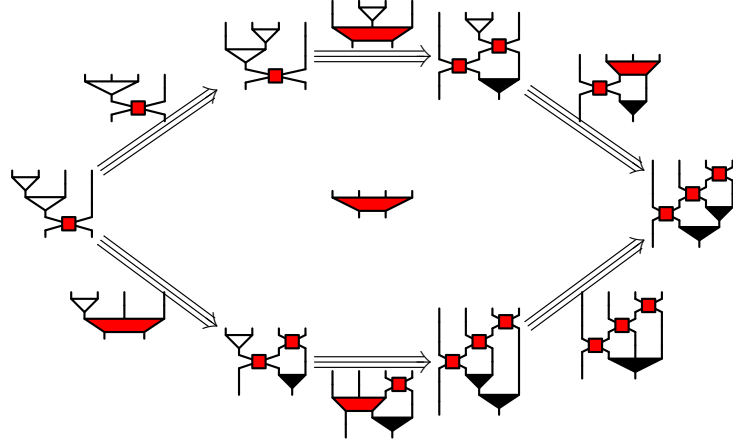

- For every $a, b \in \mathbf{C}$, 4-cells $\text{red_dot}_{a,b}$ and $\text{red_dot}_{a,b}$ of 1-source $a|b|f(b)$

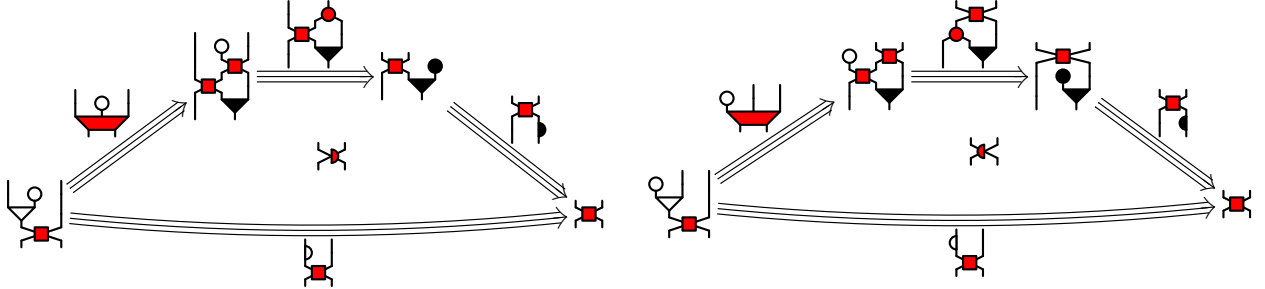

Definition 2.3.2.3. Let $\text{Alg}(\mathbf{PFonct})$ be the set of all tuples $(\mathbf{C}, \mathbf{D}, \mathbf{f}, \Phi)$:

- where \mathbf{C} and \mathbf{D} are sets,
- where \mathbf{f} is an application from \mathbf{C} to \mathbf{D} ,
- where Φ is a functor from $\overline{\mathbf{PFonct}[\mathbf{f}]}$ to \mathbf{sCat} such that, for every $c \in \mathbf{C}$ the following equality holds:

$$\Phi(\text{red_dot}_{c,c}) = \top$$

Remark 2.3.2.4. Let $\mathbf{f} : \mathbf{C} \rightarrow \mathbf{D}$ be an application. Since $\mathbf{BiCat}[\mathbf{C}]$ (resp. $\mathbf{BiCat}[\mathbf{D}]$) is a sub-4-polygraph of $\overline{\mathbf{PFonct}[\mathbf{f}]}$, every functor $\Phi : \overline{\mathbf{PFonct}[\mathbf{f}]} \rightarrow \mathbf{sCat}$ induces by restriction two functors:

$$\Phi_{\circ} : \mathbf{BiCat}[\mathbf{C}] \rightarrow \mathbf{sCat} \quad \Phi_{\bullet} : \mathbf{BiCat}[\mathbf{D}] \rightarrow \mathbf{sCat}$$

Proposition 2.3.2.5. Pseudofunctors between (small) categories are in one-to-one correspondence with elements of $\text{Alg}(\mathbf{PFonct})$.





Pseudofunctors		$Alg(\mathbf{PFonct})$	
Source and target	\mathcal{B} and \mathcal{B}'	$(\mathbf{C}, \Phi_{\mathbf{O}})$ and $(\mathbf{D}, \Phi_{\bullet})$	Restrictions
Function	F_0	\mathbf{f}	Function
Functors	F		2-cells
Natural transformations	ψ, ϕ		3-cells
Equalities	(2.3.3) (2.3.4) (2.3.5)		4-cells

Table 2.2: Correspondence for pseudofunctors

Proof. The proof is similar to the case of bicategories, using the correspondence Table 2.3.2. 

Proposition 2.3.2.6. *For every sets \mathbf{C}, \mathbf{D} and every application $\mathbf{f} : \mathbf{C} \rightarrow \mathbf{D}$, the 4-polygraph $\mathbf{PFonct}[\mathbf{f}]$ 3-terminates.*

Proof. In order to apply Theorem 2.2.1.4, we define functors $X_{\mathbf{f}} : \mathbf{PFonct}[\mathbf{f}]_2^* \rightarrow \mathbf{sOrd}$ and $Y_{\mathbf{f}} : (\mathbf{PFonct}[\mathbf{f}]_2^*)^{\text{co}} \rightarrow \mathbf{sOrd}$ as extensions of the functors $X_{\mathbf{C}}, X_{\mathbf{D}}, Y_{\mathbf{C}}$ and $Y_{\mathbf{D}}$ from Proposition 2.3.1.5, and by setting for every $a \in \mathbf{C}$:



$$X_{\mathbf{f}}(\text{alf}(a)) = Y_{\mathbf{f}}(\text{alf}(a)) = \top,$$

where \top is the terminal ordered set, and for every $i \in \mathbb{N}^*$:

$$X_{\mathbf{f}}(\text{red square})[i] = i \quad Y_{\mathbf{f}}(\text{red square})[i] = 2i + 1.$$

We now define an $(X_{\mathbf{f}}, Y_{\mathbf{f}}, \mathbb{N})$ -derivation $d_{\mathbf{f}}$ on $\mathbf{PFonct}[\mathbf{f}]_2^*$ as an extension of $d_{\mathbf{C}}$, by setting for every $i, j, k \in \mathbb{N}^*$:

$$d_{\mathbf{f}}(\text{red triangle})[i, j, k] = i + k \quad d_{\mathbf{f}}(\text{red circle})[i] = i \quad d_{\mathbf{f}}(\text{red square})[i, j] = i + j + 1$$

It remains to show that the inequalities required to apply Theorem 2.2.1.4 are satisfied. Since $X_{\mathbf{f}}$ (resp. $Y_{\mathbf{f}}$) extends $X_{\mathbf{C}}$ and $X_{\mathbf{D}}$ (resp. $Y_{\mathbf{C}}$ and $Y_{\mathbf{D}}$), the only inequalities that need to be checked are those corresponding to the 3-cells  and . Indeed, for every $i, j \in \mathbb{N}^*$, we have:

$$X_{\mathbf{f}}(\text{red circle}) = 1 \geq 1 = X_{\mathbf{f}}(\text{red circle})$$

$$X_{\mathbf{f}}(\text{red triangle})[i, j] = i + j \geq i + j = X_{\mathbf{f}}(\text{red square})[i, j]$$

$$Y_{\mathbf{f}}(\text{red triangle})[i] = (2i + 1, 2i + 1) \geq (2i + 1, 2i + 1) = Y_{\mathbf{f}}(\text{red square})[i]$$

Concerning $d_{\mathbf{f}}$, the 3-cells from $\mathbf{BiCat}[\mathbf{C}]$ have already been checked in Proposition 2.3.1.5. For the other 3-cells, we have, for every $i, j, k \in \mathbb{N}^*$:

$$d_{\mathbf{f}}(\text{red triangle})[i, j] = 2j + 1 > 0 = d_{\mathbf{f}}(\text{red circle})[i, j] \quad d_{\mathbf{f}}(\text{red circle})[i, j] = i + 2j > 0 = d_{\mathbf{f}}(\text{red triangle})[i, j]$$

$$d_{\mathbf{f}}(\text{red square})[i] = 3i + 2 > i = d_{\mathbf{f}}(\text{red circle})[i]$$

$$d_{\mathbf{f}}(\text{red triangle})[i, j, k] = 2i + j + 3k + 3 > 2i + j + 3k + 2 = d_{\mathbf{f}}(\text{red square})[i, j, k].$$





Theorem 2.3.2.7. *Let \mathbf{C} and \mathbf{D} be sets, and $f : \mathbf{C} \rightarrow \mathbf{D}$ an application.*

The 4-polygraph $\mathbf{PFonct}[f]$ is 3-convergent and the free $(4, 2)$ -category $\mathbf{PFonct}[f]^{(2)}$ is 3-coherent.*

Proof. We have shown that it is 3-terminating, so using Proposition 2.2.2.8 and Theorem 2.2.3.4, it remains to show that every critical pair admits a filler in $\mathbf{PFonct}[f]_4$.

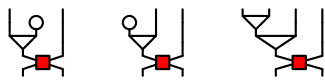
There are thirteen families of critical pairs. Among them, ten come from $\mathbf{BiCat}[\mathbf{C}]$ or $\mathbf{BiCat}[\mathbf{D}]$, and were already dealt with in Theorem 2.3.1.6. The remaining three have the following sources:



and they are filled respectively by the 4-cells ,  and .



Chapter 3

Coherence for pseudonatural transformations

Organisation

The goal of this chapter is to prove a coherence theorem for pseudonatural transformations. In the beginning of Section 3.1, we try to mimic the reasoning we used in the previous chapter to show the coherence for bicategories and pseudofunctors. We quickly realise however that the $(4, 2)$ -polygraph encoding the structure of pseudonatural transformation is not confluent, and so we cannot apply Theorem 2.2.3.4. To conclude we therefore temporarily admit a new Squier-like result: Theorem 3.1.3.5. Using this result we are able to prove the coherence for pseudonatural transformations in Section 3.1.

We then proceed to prove Theorem 3.1.3.5. First in Section 3.2 we introduce some necessary tools, and in particular the notion of white n -categories, which are n -categories where the exchange law does not hold (even up to isomorphism. Sections 3.3 and 3.4 then contain the proof of Theorem 3.1.3.5.

3.1 Proof of the coherence for pseudonatural transformations

In this section we prove a coherence theorem for pseudonatural transformations (Theorem 3.1.1.8). However, the methods we developed in the previous chapter fail in this case. To prove Theorem 3.1.1.8 we therefore rely on another result: Theorem 3.1.3.5, whose proof will occupy Sections 3.2 to 3.4. In Section 3.1.1, we start by describing the structure of pseudonatural transformation and a $(4, 2)$ -polygraph $\mathbf{PNTrans}[\mathbf{f}, \mathbf{g}]$ encoding it. A more complete overview of the proof of Theorem 3.1.1.8 is given at the end of Section 3.1.1.

3.1.1 The structure of pseudonatural transformation

Definition 3.1.1.1. A pseudonatural transformation τ consists of the following data:

- Two pseudofunctors $F, F' : \mathcal{B} \rightarrow \mathcal{B}'$, where \mathcal{B} and \mathcal{B}' are bicategories.
- For every $a \in \mathcal{B}_0$, a functor $\tau_a : \top \rightarrow \mathcal{B}'(F_0(a), F'_0(a))$, that is a 1-cell $\tau_a : F_0(a) \rightarrow F'_0(a)$ in \mathcal{B}' .
- For every $a, b \in \mathcal{B}_0$, a natural isomorphism $\sigma_{a,b}$:

$$\begin{array}{ccc}
 & \mathcal{B}(a, b) & \\
 F_{a,b} \swarrow & & \searrow F'_{a,b} \\
 \mathcal{B}'(F_0(a), F_0(b)) & & \mathcal{B}'(F'_0(a), F'_0(b)) \\
 \mathcal{B}'(F_0(a), F_0(b)) \times \tau_b \downarrow & \xrightarrow{\sigma_{a,b}} & \downarrow \tau_a \times \mathcal{B}'(F'_0(a), F'_0(b)) \\
 \mathcal{B}'(F_0(a), F_0(b)) \times \mathcal{B}'(F_0(b), F'_0(b)) & & \mathcal{B}'(F_0(a), F'_0(a)) \times \mathcal{B}'(F'_0(a), F'_0(b)) \\
 \bullet'_{F_0(a), F_0(b), F'_0(b)} \searrow & & \swarrow \bullet'_{F_0(a), F'_0(a), F'_0(b)} \\
 & \mathcal{B}'(F_0(a), F'_0(b)) &
 \end{array}$$

of components $\sigma_f : F(f) \bullet' \tau_b \Rightarrow \tau_a \bullet' F'(f)$, for every $f \in \mathcal{B}(a, b)$.

This data must satisfy the following axioms:

- For every $(f, g) \in \mathcal{B}(a, b) \times \mathcal{B}(b, c)$:

$$\begin{array}{ccc}
& \tau_a \bullet' F'(f \bullet g) & \\
\sigma_{f \bullet g} \nearrow & & \searrow \tau_a \bullet' \phi'_{f,g} \\
F(f \bullet g) \bullet' \tau_c & & \tau_a \bullet' (F'(f) \bullet' F'(g)) \\
\phi_{f,g} \bullet' \tau_c \Downarrow & & \Uparrow \alpha'_{\tau_a, F'(f), F'(g)} \\
(F(f) \bullet' F(g)) \bullet' \tau_c & = & (\tau_a \bullet' F'(f)) \bullet' F'(g) \quad (3.1.1) \\
\alpha'_{F(f), F(g), \tau_c} \Downarrow & & \Uparrow \sigma_f \bullet' F'(g) \\
F(f) \bullet' (F(g) \bullet' \tau_c) & & (F(f) \bullet' \tau_b) \bullet' F'(g) \\
F(f) \bullet' \sigma_g \searrow & & \swarrow \alpha'_{F(f), \tau_b, F(g)} \\
& F(f) \bullet' (\tau_b \bullet' F'(g)) &
\end{array}$$

- For every $a \in \mathcal{B}_0$:

$$\begin{array}{ccc}
& F(I_a) \bullet' \tau_a & \\
\psi_a \bullet' \tau_a \swarrow & & \searrow \sigma_{I_a} \\
I'_{F_0(a)} \bullet' \tau_a & = & \tau_a \bullet' F'(I_a) \\
L'_{\tau_a} \searrow & & \Downarrow \tau_a \bullet' \psi'_a \\
& \tau_a & \tau_a \bullet' I'_{F'_0(a)} \\
& & \swarrow R'_{\tau_a}
\end{array} \quad (3.1.2)$$

Definition 3.1.1.2. Let \mathbf{C} and \mathbf{D} be sets, and \mathbf{f}, \mathbf{g} be applications from \mathbf{C} to \mathbf{D} . Let us define dimension by dimension a $(4, 2)$ -polygraph $\mathbf{PNTrans}[\mathbf{f}, \mathbf{g}]$. We will see in Proposition 3.1.1.5 that pseudonatural transformations correspond to algebras over $\mathbf{PNTrans}[\mathbf{f}, \mathbf{g}]$.

The polygraph $\mathbf{PNTrans}[\mathbf{f}, \mathbf{g}]$ contains the union of the polygraphs $\mathbf{PFonct}[\mathbf{f}]$ and $\mathbf{PFonct}[\mathbf{g}]$. In particular, the following cells are in $\mathbf{PNTrans}[\mathbf{f}, \mathbf{g}]$:

- the cells $\nabla, \varphi, \triangleleft, \triangleright, \delta, \triangleleft', \triangleright'$ coming from $\mathbf{BiCat}[\mathbf{C}]$,
- the cells $\nabla, \varphi, \triangleleft, \triangleright, \delta, \triangleleft', \triangleright'$ coming from $\mathbf{BiCat}[\mathbf{D}]$,
- the cells $\boxplus, \boxminus, \boxplus', \boxminus', \boxtimes, \boxtimes'$ coming from $\mathbf{PFonct}[\mathbf{f}]$,
- the cells $\boxplus, \boxminus, \boxplus', \boxminus', \boxtimes, \boxtimes'$ coming from $\mathbf{PFonct}[\mathbf{g}]$.

Together with the union of $\mathbf{PFonct}[\mathbf{f}]$ and $\mathbf{PFonct}[\mathbf{g}]$, $\mathbf{PNTrans}[\mathbf{f}, \mathbf{g}]$ contains the following cells:

Dimension 2: For every $a \in \mathbf{C}$, the set $\mathbf{PNTrans}[\mathbf{f}, \mathbf{g}]_2$ contains a 2-cell $\mathbb{1}_a : a|_{\mathbf{g}(a)} \Rightarrow a\mathbf{f}(a)|_{\mathbf{g}(a)}$.

Dimension 3: For every $a, b \in \mathbf{C}$, the set $\mathbf{PNTrans}[\mathbf{f}, \mathbf{g}]_3$ contains a 3-cell: $\mathbb{2}_{a,b} : \mathbb{1}_a \Rightarrow \mathbb{1}_b$ of 1-source $a|_{\mathbf{g}(b)}$.

Dimension 4: The set $\mathbf{PNTrans}[\mathbf{f}, \mathbf{g}]_4$ contains the following 4-cells:

- For every $a \in \mathbf{C}$, a 4-cell $\mathbb{3}_a$ of 1-source $a|_{\mathbf{g}(a)}$

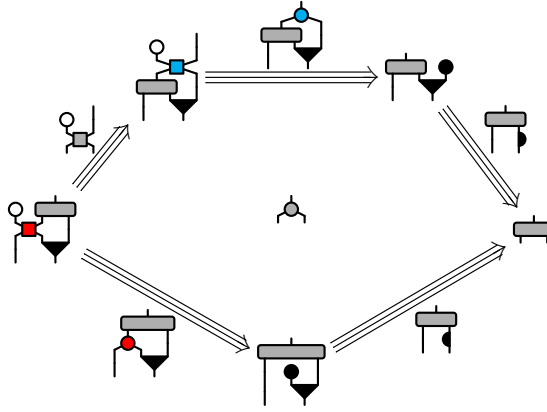

- For every $a, b, c \in \mathbf{C}$, a 4-cell $\mathbb{4}_{a,b,c}$ of 1-source $a|_{\mathbf{g}(c)}$

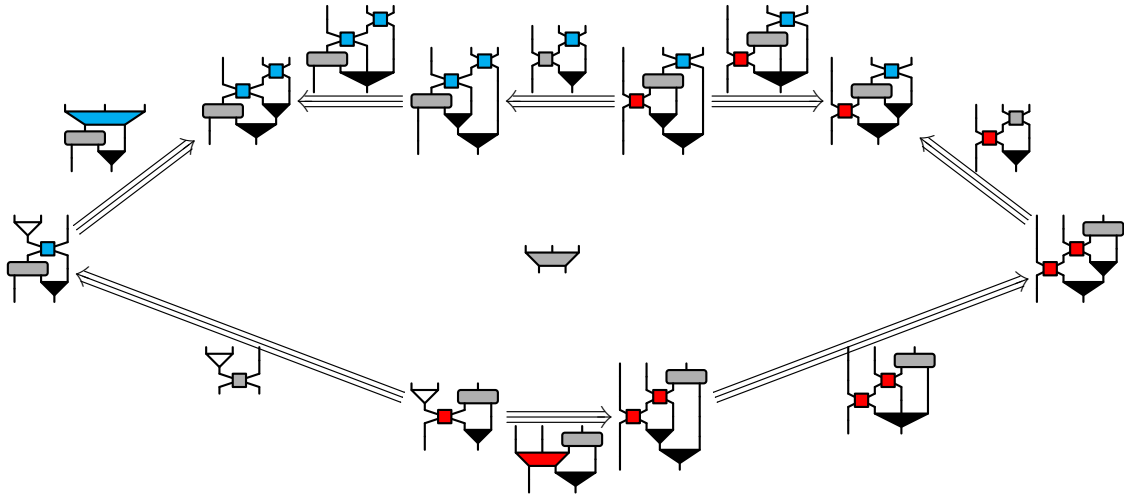

Definition 3.1.1.3. Let $\mathbf{Alg}(\mathbf{PNTrans})$ be the set of tuples $(\mathbf{C}, \mathbf{D}, \mathbf{f}, \mathbf{g}, \Phi)$:

- where \mathbf{C} and \mathbf{D} are sets,
- where $\mathbf{f}, \mathbf{g} : \mathbf{C} \rightarrow \mathbf{D}$ are applications,
- where Φ is a functor from $\overline{\mathbf{PNTrans}[\mathbf{f}, \mathbf{g}]}$ to \mathbf{sCat} , such that for every $c \in \mathbf{C}$, $d \in \mathbf{D}$ and 1-cell $| : c \rightarrow d$:

$$\Phi(|_d) = \top$$

Remark 3.1.1.4. Since $\mathbf{PFonct}[f]$ (resp. $\mathbf{PFonct}[g]$) is a sub-4-polygraph of $\mathbf{PNTrans}[f, g]$, every functor $\Phi : \overline{\mathbf{PNTrans}}[f, g] \rightarrow \mathbf{sCat}$ induces by restriction two functors

$$\Phi_{\bullet} : \overline{\mathbf{PFonct}}[f] \rightarrow \mathbf{sCat} \quad \Phi_{\circ} : \overline{\mathbf{PFonct}}[g] \rightarrow \mathbf{sCat}$$

Proposition 3.1.1.5. *Pseudonatural transformations between pseudofunctors are in one-to-one correspondence with elements of $\text{Alg}(\mathbf{PNTrans})$.*

Proof. The proof is similar to that of bicategories, using Table 3.1.



Pseudonatural transformations		$\text{Alg}(\mathbf{PNTrans})$	
Source and target Functors	F and F'	Φ_{\bullet} and Φ_{\circ}	Restrictions
Natural transformations	τ		2-cells
Equalities	σ		3-cells
	(3.1.1) (3.1.2)		4-cells

Table 3.1: Correspondence for pseudonatural transformations

□

This result induces the classification presented in Table 3.2 of the cells of the $(4, 2)$ -polygraph $\mathbf{PNTrans}[f, g]$, depending on which structure they come from. We also distinguish two types of cells: *product cells* and *unit cells*. Moreover, in Table 3.2, every line corresponds to a dimension.





























Origin	Dimension	Product cells	Unit cells
Source bicategory	2-cells		
	3-cells		
	4-cells		
Target bicategory	2-cells		
	3-cells		
	4-cells		
Source pseudofunctor	2-cells		
	3-cells		
	4-cells		
Target pseudofunctor	2-cells		
	3-cells		
	4-cells		
Pseudonatural transformation	2-cells		
	3-cells		
	4-cells		

Table 3.2: Classification of the cells of $\mathbf{PNTrans}[f, g]$

Proposition 3.1.1.6. *Let $f, g : \mathbf{C} \rightarrow \mathbf{D}$ be two applications. The $(4, 2)$ -polygraph $\mathbf{PNTrans}[f, g]$ 3-terminates.*

Proof. We apply Theorem 2.2.1.4. To construct the functors $X_{f,g} : \mathbf{PNTrans}[f, g]_2^* \rightarrow \mathbf{sOrd}$ and $Y_{f,g} : (\mathbf{PNTrans}[f, g]_2^*)^{\text{co}} \rightarrow \mathbf{sOrd}$, we extend the functors X_f, X_g, Y_f and Y_g from Proposition 2.3.2.6, by setting:

$$X_{f,g}(\text{rectangle with horizontal line}) = 1$$

We now define an $(X_{\mathbf{f},\mathbf{g}}, Y_{\mathbf{f},\mathbf{g}}, \mathbb{N})$ -derivation $d_{\mathbf{f},\mathbf{g}}$ of the 2-category $\mathbf{PNTrans}[\mathbf{f}, \mathbf{g}]_2^*$ as the extension of $d_{\mathbf{f}}$ satisfying, for every $i, j \in \mathbb{N}^*$:

$$d_{\mathbf{f},\mathbf{g}}(\text{[diagram]})[i, j] = i + j \quad d_{\mathbf{f},\mathbf{g}}(\text{[diagram]})[i] = i$$

It remains to show that the required inequalities are satisfied. Since $X_{\mathbf{f},\mathbf{g}}$ (resp. $Y_{\mathbf{f},\mathbf{g}}$) is an extension $X_{\mathbf{f}}$ and $X_{\mathbf{g}}$ (resp. $Y_{\mathbf{f}}$ and $Y_{\mathbf{g}}$), it only remains to treat the case of the 3-cell [diagram] . For every $i, j \in \mathbb{N}^*$, we have:

$$X_{\mathbf{f},\mathbf{g}}(\text{[diagram]})[i] = i + 1 \geq i + 1 = X_{\mathbf{f},\mathbf{g}}(\text{[diagram]})[i] \quad Y_{\mathbf{f},\mathbf{g}}(\text{[diagram]})[i] = 2i + 1 \geq 2i + 1 = Y_{\mathbf{f},\mathbf{g}}(\text{[diagram]})[i]$$

Concerning $d_{\mathbf{f},\mathbf{g}}$, the 3-cells from $\mathbf{PFonct}[\mathbf{f}]$ were already treated in Proposition 2.3.1.5. For the others we have, for every $i, j, k \in \mathbb{N}^*$:

$$d_{\mathbf{f},\mathbf{g}}(\text{[diagram]})[i, j, k] = 2i + j + 3k + 2 > 2i + j + 3k = d_{\mathbf{f},\mathbf{g}}(\text{[diagram]})[i, j, k]$$

$$d_{\mathbf{f},\mathbf{g}}(\text{[diagram]}) = 3i + 1 > i = d_{\mathbf{f},\mathbf{g}}(\text{[diagram]}) \quad d_{\mathbf{f},\mathbf{g}}(\text{[diagram]})[i, j] = 2i + 3j + 1 > i + 3j + 1 = d_{\mathbf{f},\mathbf{g}}(\text{[diagram]})[i, j]$$

□

Definition 3.1.1.7. We define a *weight* application \mathbf{w} as the 1-functor from $\mathbf{PNTrans}[\mathbf{f}, \mathbf{g}]_1^*$ to \mathbb{N} , defined as follows on $\mathbf{PNTrans}[\mathbf{f}, \mathbf{g}]_1$:

- for all $a, b \in \mathbf{C}$, $\mathbf{w}(a|b) = 1$,
- for all $a, b \in \mathbf{D}$, $\mathbf{w}(a|b) = 1$,
- for all $a \in \mathbf{C}$ and $b \in \mathbf{D}$, $\mathbf{w}(a|b) = 0$.

Theorem 3.1.1.8 (Coherence for pseudonatural transformations). *Let \mathbf{C} and \mathbf{D} be sets, and $\mathbf{f}, \mathbf{g} : \mathbf{C} \rightarrow \mathbf{D}$ applications.*

Let $A, B \in \mathbf{PNTrans}[\mathbf{f}, \mathbf{g}]_3^{(2)}$ be two parallel 3-cells whose 1-target is of weight 1.*

There is a 4-cell $\alpha : A \rightrightarrows B \in \mathbf{PNTrans}[\mathbf{f}, \mathbf{g}]_4^{(2)}$.*

This proof of this theorem will occupy the rest of Section 3.1. Contrary to the case of bicategories and pseudofunctors, we cannot directly apply Theorem 2.2.3.4 to the $(4, 2)$ -polygraph $\mathbf{PNTrans}[\mathbf{f}, \mathbf{g}]$, because the following critical pair is not confluent:

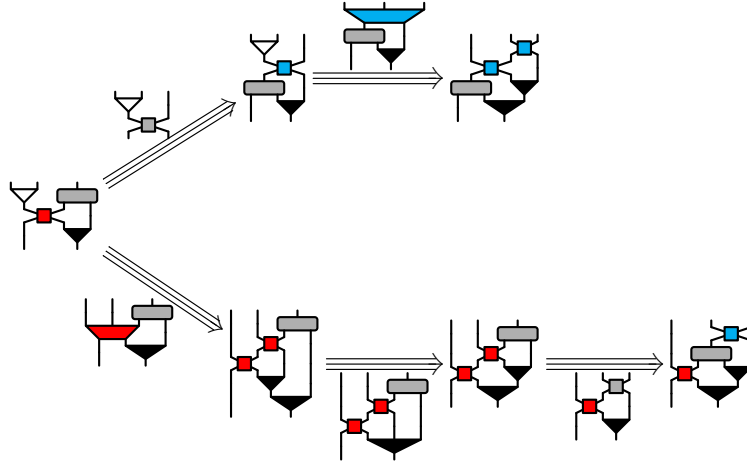

Let us give a quick overview of the proof of Theorem 3.1.1.8. We fix for the rest of this section two sets \mathbf{C} and \mathbf{D} , together with two applications $\mathbf{f}, \mathbf{g} : \mathbf{C} \rightarrow \mathbf{D}$. Let $A, B \in \mathbf{PNTrans}[\mathbf{f}, \mathbf{g}]^{*(2)}$ be 3-cells whose 1-target is of weight 1. We want to build a 4-cell $\alpha : A \Rightarrow B \in \mathbf{PNTrans}[\mathbf{f}, \mathbf{g}]^{*(2)}$.

The 1-cells of weight 1 are of one of the following forms, with $a, a' \in \mathbf{C}$ and $b, b' \in \mathbf{D}$:

$$a|a' \quad bb' \quad a|a'|f(a') \quad a|a'|g(a') \quad a|a'|f(a') \quad a|g(a)|b \quad a|f(a)|b$$

We start in Section 3.1.2 by show that if the common 1-target of A and B is not of the last form, then they are generated by a sub-4-polygraph $\mathbf{PFonct}[\mathbf{f}, \mathbf{g}]$ of $\mathbf{PNTrans}[\mathbf{f}, \mathbf{g}]$. We then show using Theorem 2.2.3.4 that this 4-polygraph is coherent.

There remains to treat the case where the 1-target of A and B is of the last form. We define two sub-(4, 2)-polygraphs of $\mathbf{PNTrans}[\mathbf{f}, \mathbf{g}]$: $\mathbf{PNTrans}^{++}[\mathbf{f}, \mathbf{g}]$ and $\mathbf{PNTrans}^+[\mathbf{f}, \mathbf{g}]$. The (4, 2)-polygraph $\mathbf{PNTrans}^{++}[\mathbf{f}, \mathbf{g}]$ contains all the structure of pseudonatural transformations, except for the axioms concerning the units φ and ψ , while $\mathbf{PNTrans}^+[\mathbf{f}, \mathbf{g}]$ is constructed from $\mathbf{PNTrans}^{++}[\mathbf{f}, \mathbf{g}]$ by adding the 2-cells φ and ψ (but not the higher dimensional cells where they appear). The inclusions between the (4, 2)-polygraphs can be seen as follows:

$$\mathbf{PNTrans}^{++}[\mathbf{f}, \mathbf{g}]_2 \subset \mathbf{PNTrans}^+[\mathbf{f}, \mathbf{g}]_2 = \mathbf{PNTrans}[\mathbf{f}, \mathbf{g}]_2$$

$$\mathbf{PNTrans}^{++}[\mathbf{f}, \mathbf{g}]_3 = \mathbf{PNTrans}^+[\mathbf{f}, \mathbf{g}]_3 \subset \mathbf{PNTrans}[\mathbf{f}, \mathbf{g}]_3$$

In Section 3.1.3, we show that $\mathbf{PNTrans}^{++}[\mathbf{f}, \mathbf{g}]$ satisfies the 2-Squier condition of depth 2, which allows us to apply Theorem 3.1.3.5. But this only solves the problem whenever $A, B \in \mathbf{PNTrans}^{++}[\mathbf{f}, \mathbf{g}]^{*(2)}$. In order to extend that to the rest of $\mathbf{PNTrans}[\mathbf{f}, \mathbf{g}]^{*(2)}$, we then define a sub-3-polygraph $\mathbf{PNTrans}^u[\mathbf{f}, \mathbf{g}]$ of $\mathbf{PNTrans}[\mathbf{f}, \mathbf{g}]$. The rewriting system induced by the 3-cells $\mathbf{PNTrans}^u[\mathbf{f}, \mathbf{g}]$ corresponds to simplifying the units out.

Using the properties of this rewriting system, we extend the result of Section 3.1.3, first to 3-cells A and B in $\mathbf{PNTrans}^+[\mathbf{f}, \mathbf{g}]^{*(2)}$ in Section 3.1.4, and finally to general A and B whose 1-target is $a|f(a)|b$ in Section 3.1.5, thereby concluding the proof.

3.1.2 A convergent sub-polygraph of $\mathbf{PNTrans}[\mathbf{f}, \mathbf{g}]$

Definition 3.1.2.1. Let $\mathbf{PFonct}[\mathbf{f}, \mathbf{g}]$ be the 4-polygraph containing every cell of $\mathbf{PNTrans}[\mathbf{f}, \mathbf{g}]$, except those corresponding to the pseudonatural transformation. Alternatively, $\mathbf{PFonct}[\mathbf{f}, \mathbf{g}]$ is the union of $\mathbf{PFonct}[\mathbf{f}]$ and $\mathbf{PFonct}[\mathbf{g}]$.

Lemma 3.1.2.2. For every $h \in \mathbf{PNTrans}[\mathbf{f}, \mathbf{g}]_2^*$, one of the following holds:

- The target of h is of the form

$$a_1 | \cdots | a_i | f(a_i) | b_1 | \cdots | b_j, \tag{3.1.3}$$

where i and j are non-zero integers, the a_k are in \mathbf{C} and the b_k are in \mathbf{D} .

- The 2-cell h is in $\mathbf{PFonct}[\mathbf{f}, \mathbf{g}]_2^*$.

Proof. Let us show first that the set of all 1-cells of the form (3.1.3) is stable when rewritten by $\mathbf{PFonct}[\mathbf{f}, \mathbf{g}]_2^*$. To prove this, we examine the case of every cell of $\mathbf{PFonct}[\mathbf{f}, \mathbf{g}]_2^*$ of length 1:

$$\begin{aligned} a_1 | \cdots | a_{k-1} | \nabla_{a_{k+1}} | \cdots | b_j &: a_1 | \cdots | a_i | f(a_i) | b_1 | \cdots | b_j \Rightarrow a_1 | \cdots | a_{k-1} | a_{k+1} | \cdots | b_j \\ a_1 | \cdots | a_k | \varphi_{a_k} | \cdots | b_j &: a_1 | \cdots | a_i | f(a_i) | b_1 | \cdots | b_j \Rightarrow a_1 | \cdots | a_k | a_k | \cdots | b_j \\ a_1 | \cdots | b_{k-1} | \nabla_{b_{k+1}} | \cdots | b_j &: a_1 | \cdots | a_i | f(a_i) | b_1 | \cdots | b_j \Rightarrow a_1 | \cdots | b_{k-1} | b_{k+1} | \cdots | b_j \end{aligned}$$

$$a_1 | \cdots | b_k \bullet b_k | \cdots | b_j : a_1 | \cdots | a_i | f(a_i) | b_1 | \cdots | b_j \Rightarrow a_1 | \cdots | b_k | b_k | \cdots | b_j$$

$$a_1 | \cdots | a_{i-1} | f(a_i) | \cdots | b_j : a_1 | \cdots | a_i | f(a_i) | b_1 | \cdots | b_j \Rightarrow a_1 | \cdots | a_{i-1} | f(a_{i-1}) | f(a_i) | b_1 | \cdots | b_j$$

Let us now prove the lemma: we reason by induction on the length of h . If h is of length 0, it is an identity, so h is in $\mathbf{PFonct}[\mathbf{f}, \mathbf{g}]^*$.

If h is of length 1 and h is not in $\mathbf{PFonct}[\mathbf{f}, \mathbf{g}]^*$, then h has to be of the form $|\cdots| \text{ } \begin{array}{c} \text{---} \\ \text{---} \end{array} |\cdots|$. So its target is of the form:

$$a_1 | \cdots | a_k | f(a_k) | g(a_k) | b_2 | \cdots | b_j$$

which is indeed of the form (3.1.3), with $b_1 = \mathbf{g}(a_k)$.

Let now h be of length $n > 1$. We can write $h = h_1 \bullet_1 h_2$, where h_2 is of length 1, and h_1 is strictly shorter than h . Let us apply the induction hypothesis to h_2 . If the target of h_2 is of the form (3.1.3), then so is the target of h , since $t(h_2) = t(h)$. Otherwise, then $h_1 \in \mathbf{PFonct}[\mathbf{f}, \mathbf{g}]^*$, and we can apply the induction hypothesis to h_2 . If h_2 also is in $\mathbf{PFonct}[\mathbf{f}, \mathbf{g}]^*$, then so is h .

It remains to treat the case where $t(h_1)$ is of the form (3.1.3), and h_2 is in $\mathbf{PFonct}[\mathbf{f}, \mathbf{g}]^*$. But we have shown that the 1-cells of the form (3.1.3) are stable when rewritten by $\mathbf{PFonct}[\mathbf{f}, \mathbf{g}]^*$. Thus, the target of h_2 (which is the target of h) is of the form (3.1.3), which concludes the proof. \square

Lemma 3.1.2.3. *For every $A \in \mathbf{PNTrans}[\mathbf{f}, \mathbf{g}]_3^{*(2)}$, one of the following holds:*

- The 1-target of A is of the form (3.1.3).
- The 3-cell A is in $\mathbf{PFonct}[\mathbf{f}, \mathbf{g}]_3^{*(2)}$.

Proof. Let us start by the case where A is a 3-cell of length 1 in $\mathbf{PNTrans}[\mathbf{f}, \mathbf{g}]_3^*$. If the 1-target of A is not of the form (3.1.3) then, according to Lemma 3.1.2.2, the 2-source of A is in $\mathbf{PFonct}[\mathbf{f}, \mathbf{g}]_2^*$. The only 3-cell in $\mathbf{PNTrans}[\mathbf{f}, \mathbf{g}]_3$ which is not in $\mathbf{PFonct}[\mathbf{f}, \mathbf{g}]_3$ is the 3-cell $\begin{array}{c} \text{---} \\ \text{---} \end{array}$, whose 2-source $\begin{array}{c} \text{---} \\ \text{---} \end{array}$ is not in $\mathbf{PFonct}[\mathbf{f}, \mathbf{g}]_2^*$. Thus A is in $\mathbf{PFonct}[\mathbf{f}, \mathbf{g}]_3^*$.

Suppose now that $A = B^{-1}$, where B is a 3-cell of $\mathbf{PNTrans}[\mathbf{f}, \mathbf{g}]_3^*$ of length 1. The 1-target of B is the same as the one of A . If it is not of the form (3.1.3), B is in $\mathbf{PFonct}[\mathbf{f}, \mathbf{g}]_3^{*(2)}$, and so is A .

In the general case, A is a composite of 3-cells of one of the two previous forms, and all of them have the same 1-target as A . Thus if the 1-target of A is not of the form (3.1.3), all those 3-cells are in $\mathbf{PFonct}[\mathbf{f}, \mathbf{g}]_3^{*(2)}$, and so is A . \square

Lemma 3.1.2.4. *The 4-polygraph $\mathbf{PFonct}[\mathbf{f}, \mathbf{g}]$ is 3-coherent.*

Proof. It is a sub-4-polygraph of $\mathbf{PNTrans}[\mathbf{f}, \mathbf{g}]$ which is 3-terminating, therefore it is also 3-terminating. Moreover, every critical pair in $\mathbf{PFonct}[\mathbf{f}, \mathbf{g}]$ arises from one either in $\mathbf{PFonct}[\mathbf{f}]$ or $\mathbf{PFonct}[\mathbf{g}]$. Since those 4-polygraphs are confluent and satisfy the Squier condition, so does $\mathbf{PFonct}[\mathbf{f}, \mathbf{g}]$.

Using Theorem 2.2.3.4, this means that $\mathbf{PFonct}[\mathbf{f}, \mathbf{g}]$ is 3-coherent. \square

Proposition 3.1.2.5. *Let $\mathbf{f}, \mathbf{g} : \mathbf{C} \rightarrow \mathbf{D}$ be two applications.*

For every parallel 3-cells $A, B \in \mathbf{PNTrans}[\mathbf{f}, \mathbf{g}]^{(2)}$ whose 1-target is not of the form (3.1.3), there exists a 4-cell $\alpha : A \Rrightarrow B \in \mathbf{PNTrans}[\mathbf{f}, \mathbf{g}]_4^{*(2)}$.*

In particular, for every parallel 3-cells $A, B \in \mathbf{PNTrans}[\mathbf{f}, \mathbf{g}]^{(2)}$ whose 1-target is of weight 1 and is not of the form $a | f(a) | b$, there exists a 4-cell $\alpha : A \Rrightarrow B \in \mathbf{PNTrans}[\mathbf{f}, \mathbf{g}]_4^{*(2)}$.*

Proof. Let $A, B \in \mathbf{PNTrans}[\mathbf{f}, \mathbf{g}]_3^{*(2)}$ whose 1-target is not of the form (3.1.3). We want to build a 4-cell $\alpha : A \Rrightarrow B \in \mathbf{PNTrans}[\mathbf{f}, \mathbf{g}]_4^{*(2)}$. According to Lemma 3.1.2.3, A and B are actually 3-cells in $\mathbf{PFonct}[\mathbf{f}, \mathbf{g}]_3^{*(2)}$. In Lemma 3.1.2.4, we showed that $\mathbf{PFonct}[\mathbf{f}, \mathbf{g}]$ is 3-coherent, hence there exists a 4-cell $\alpha : A \Rrightarrow B \in \mathbf{PFonct}[\mathbf{f}, \mathbf{g}]_4^{*(2)} \subset \mathbf{PNTrans}[\mathbf{f}, \mathbf{g}]_4^{*(2)}$.

Moreover, the only 1-cells of weight 1 and of the form (3.1.3) are the 1-cells $a|_{\mathbf{f}(a)}|_b$, which proves the second part of the Proposition. \square

3.1.3 The 2-Squier condition of depth 2 and $\mathbf{PNTrans}[\mathbf{f}, \mathbf{g}]$

In this section, we finally state Theorem 3.1.3.5, and show that a sub-polygraph of $\mathbf{PNTrans}[\mathbf{f}, \mathbf{g}]$ satisfies its hypothesis. The proof of Theorem 3.1.3.5 will occupy Sections 3.2 to 3.4.

Definition 3.1.3.1. Let $\mathbf{PNTrans}^{++}[\mathbf{f}, \mathbf{g}]$ be the sub-(4, 2)-polygraph of $\mathbf{PNTrans}[\mathbf{f}, \mathbf{g}]$ containing every product cell from Table 3.2.

Definition 3.1.3.2. Let Σ be an $(n + 1)$ -polygraph, and (f, g) a local branching in Σ_n . Depending on the nature of (f, g) , we define the notion of *canonical filling* of (f, g) .

- If (f, g) is an aspherical branching, then its canonical filling is the identity 1_f .
- If (f, g) is a Peiffer branching, if $(f, g) = (f' \bullet_i v_1, v_2 \bullet_i g')$ (resp. $(f, g) = (v_1 \bullet_i f', g' \bullet_i v_2)$), then its canonical filling is $1_{f' \bullet_i g'}$ (resp. $1_{g' \bullet_i f'}$).
- Assume that Σ satisfies the n -Squier condition, and let (f, g) be a critical pair. Let A be the $(n + 1)$ -cell associated to $[f, g]$. If A is a filling of (f, g) , then the canonical filling of (f, g) is A . Otherwise, A is a filling of (g, f) and the canonical filling of (f, g) is A^{-1} .
- Assume that the branching (f, g) admits a canonical filler A . Then the canonical filler of $(u \bullet_i f \bullet_i v, u \bullet_i f \bullet_i v)$ is $u \bullet_i A \bullet_i v$.

Definition 3.1.3.3. Let Σ be an $(n + 2, n)$ -polygraph satisfying the n -Squier condition, and (f, g, h) be a local branching of Σ_n . A *filling* of (f, g, h) is an $(n + 2)$ -cell $\alpha \in \Sigma_{n+2}^{*(n)}$ of the shape:

$$\begin{array}{ccc}
 \begin{array}{c} \nearrow f \\ \longrightarrow g \\ \searrow h \end{array} & \begin{array}{c} \xrightarrow{A_{f,g}} \\ \xrightarrow{A} \\ \xrightarrow{A_{g,h}} \end{array} & \begin{array}{c} \xrightarrow{\alpha} \\ \xrightarrow{A_{f,h}} \\ \xrightarrow{B_2} \end{array} \\
 & & \begin{array}{c} \xrightarrow{B_1} \\ \xrightarrow{B_2} \end{array} \\
 \end{array} \tag{3.1.4}$$

where $A, A_{f,g}, A_{g,h}, A_{f,h}, B_1$ and B_2 are $(n + 1)$ -cells in $\Sigma_{n+1}^{*(n)}$, and $A_{f,g}, A_{g,h}$ and $A_{f,h}$ are the canonical fillings of respectively (f, g) , (g, h) and (f, h) .

Definition 3.1.3.4. An $(n + 2, n)$ -polygraph Σ satisfies the *n -Squier condition of depth 2* if:

- it satisfies the n -Squier condition,
- there is a bijective application from Σ_{n+2} to the set of all critical triples of Σ_n that associates to every $\alpha \in \Sigma_{n+2}$ a critical triple b of Σ_n such that α is a filling of a representative of b .

Theorem 3.1.3.5. *Let \mathcal{A} be a $(4, 2)$ -polygraph satisfying the 2-Squier condition of depth 2.*

For every parallel 3-cells $A, B \in \Sigma_3^{(2)}$ whose 1-target is a normal form, there exists a 4-cell $\alpha : A \Rrightarrow B$ in the free $(4, 2)$ -category $\Sigma_4^{*(2)}$.*

This theorem should be compared with Proposition 4.4.4 in [40]. There, for every parallel $A, B \in \Sigma_3^{*(1)}$, a 4-cell $\alpha : A \Rrightarrow B$ is constructed in the free $(4, 1)$ -category $\Sigma_4^{*(1)}$. By not requiring the inversibility of the 2-cells, Theorem 3.1.3.5 gives a more precise statement, at the cost of restricting the set of 3-cells allowed.

Lemma 3.1.3.6. *The $(4, 2)$ -polygraph $\mathbf{PNTrans}^{++}[\mathbf{f}, \mathbf{g}]$ satisfies the 2-Squier condition of depth 2.*

Proof. **The 2-Squier condition**

Let us start by showing the 2-termination of the $(4, 2)$ -polygraph $\mathbf{PNTrans}^{++}[\mathbf{f}, \mathbf{g}]$.

We define a functor $\tau : \mathbf{PNTrans}[\mathbf{f}, \mathbf{g}]_1^* \rightarrow \mathbb{N}^3$, where compositions in \mathbb{N}^3 are given by component-wise addition, by defining:

- For all $a, b \in \mathbf{C}$, $\tau(a|b) = (1, 0, 0)$.
- For all $a \in \mathbf{C}$, $\tau(a|_{\mathbf{f}(a)}) = (0, 1, 0)$.
- For all $a \in \mathbf{C}$, $\tau(a|_{\mathbf{g}(a)}) = (0, 2, 0)$.
- For all $a, b \in \mathbf{D}$, $\tau(a|b) = (0, 0, 1)$.

The lexicographic order on \mathbb{N}^3 induces a noetherian ordering on $\mathbf{PNTrans}[\mathbf{f}, \mathbf{g}]_1^*$. Moreover, the 2-cells are indeed decreasing for this order:

$$\tau(s(\nabla)) = (2, 0, 0) > (1, 0, 0) = \tau(t(\nabla)) \quad \tau(s(\blacktriangledown)) = (0, 0, 2) > (0, 0, 1) = \tau(t(\blacktriangledown))$$

$$\tau(s(\blacksquare)) = (1, 1, 0) > (0, 1, 1) = \tau(t(\blacksquare)) \quad \tau(s(\blacklozenge)) = (1, 2, 0) > (0, 2, 1) = \tau(t(\blacklozenge))$$

$$\tau(s(\square)) = (0, 2, 0) > (0, 1, 1) = \tau(t(\square))$$

The following diagrams show both the 2-confluence of $\mathbf{PNTrans}^{++}[\mathbf{f}, \mathbf{g}]$ and the correspondence between critical pairs and 3-cells:

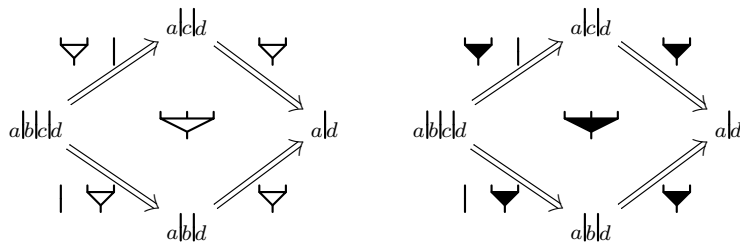

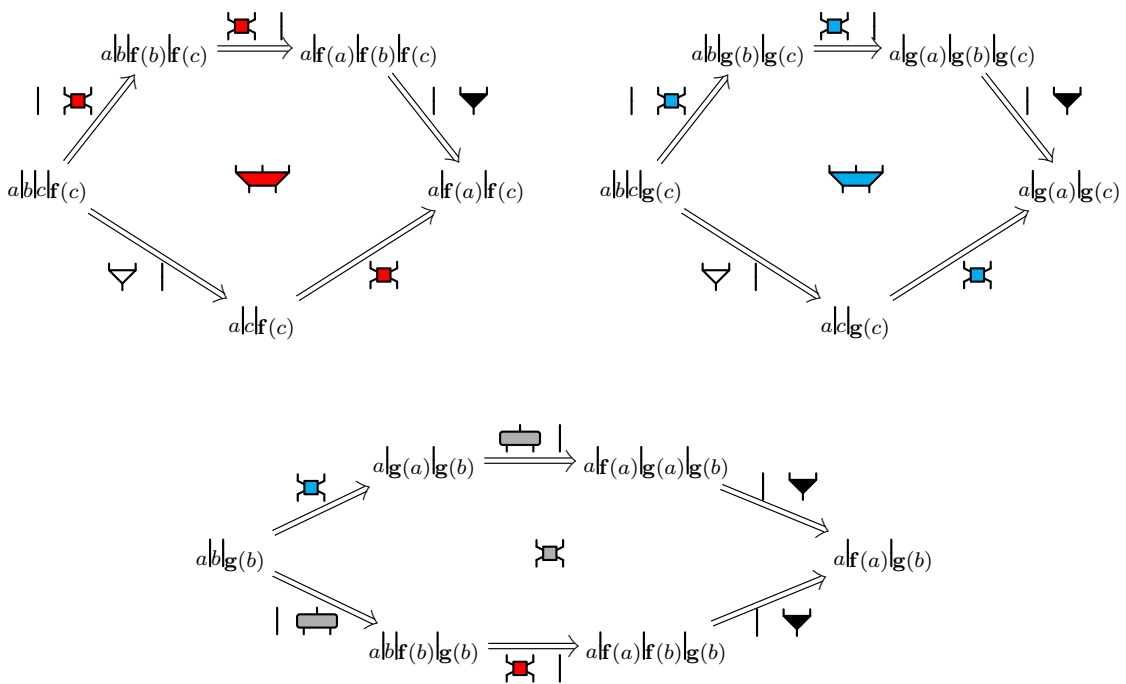

The 2-Squier condition of depth 2

The following diagrams show the bijection between critical triples and 4-cells.

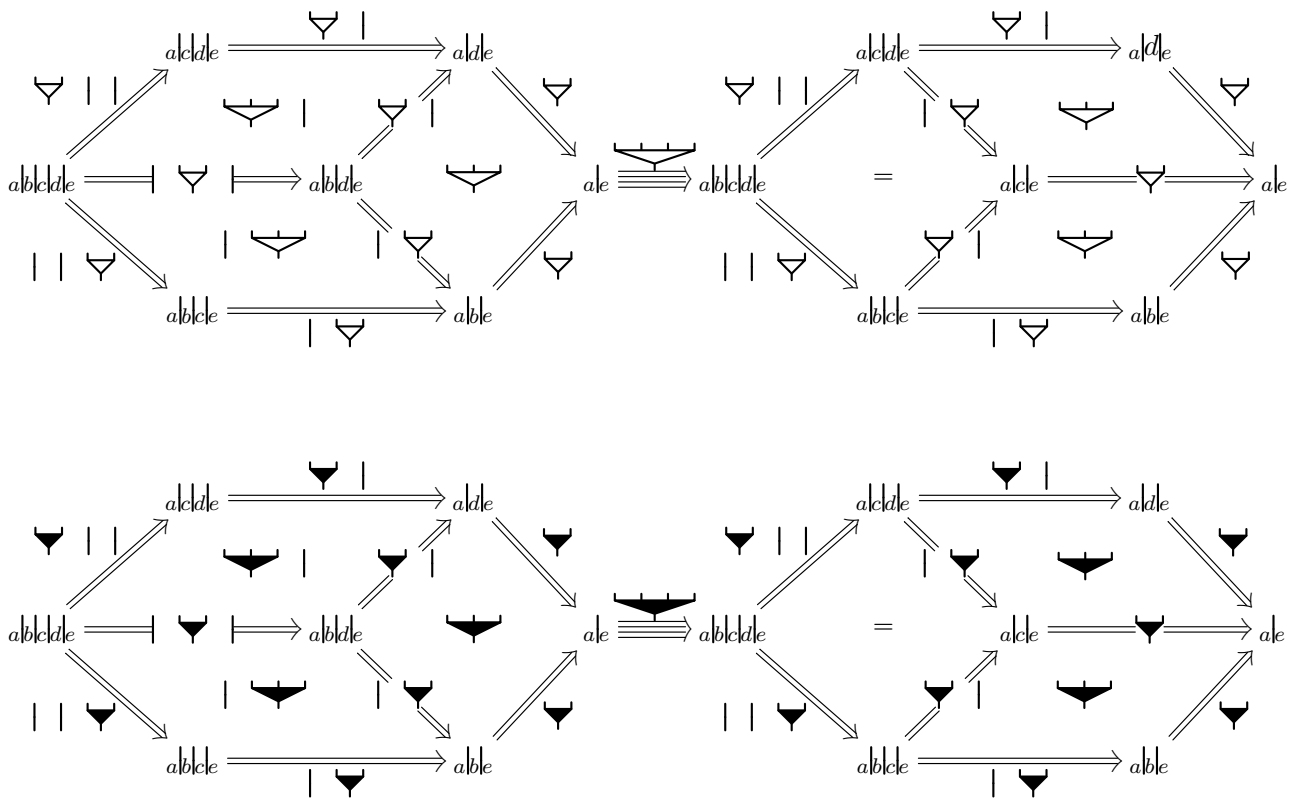

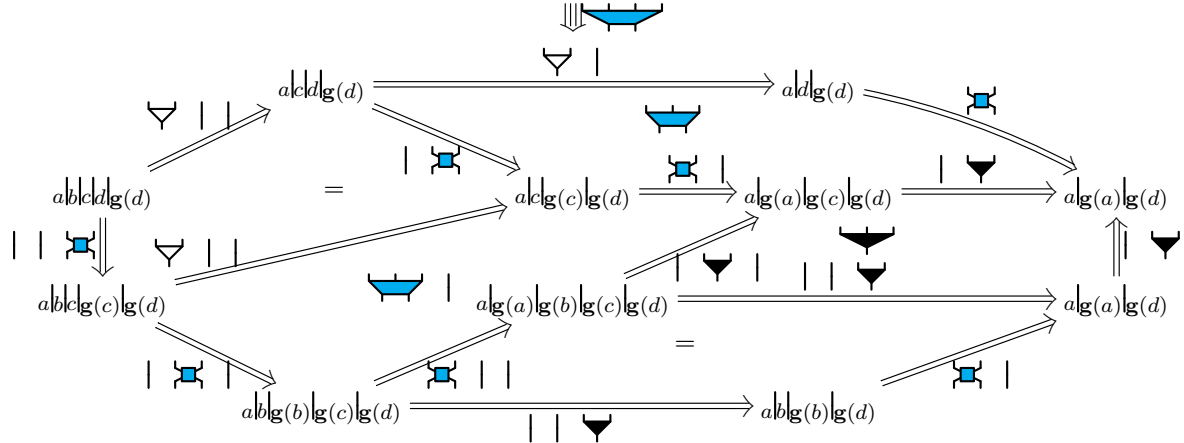
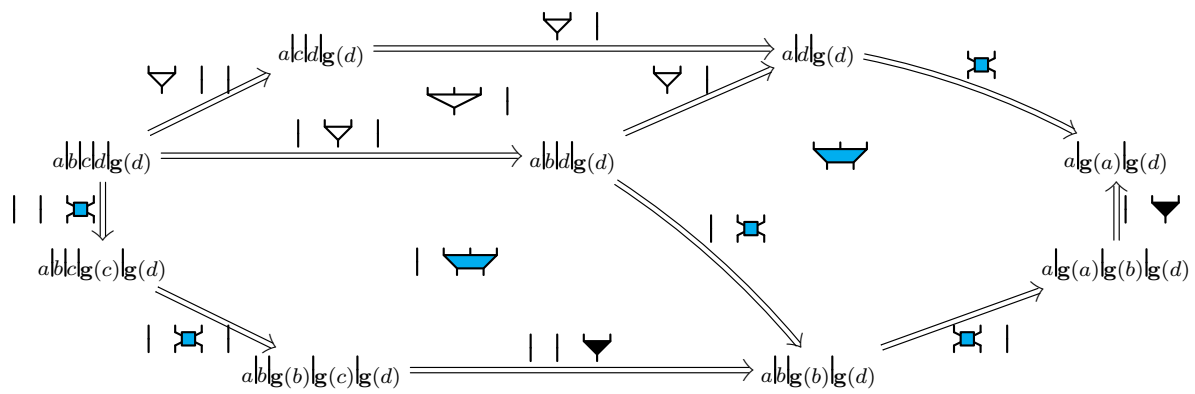
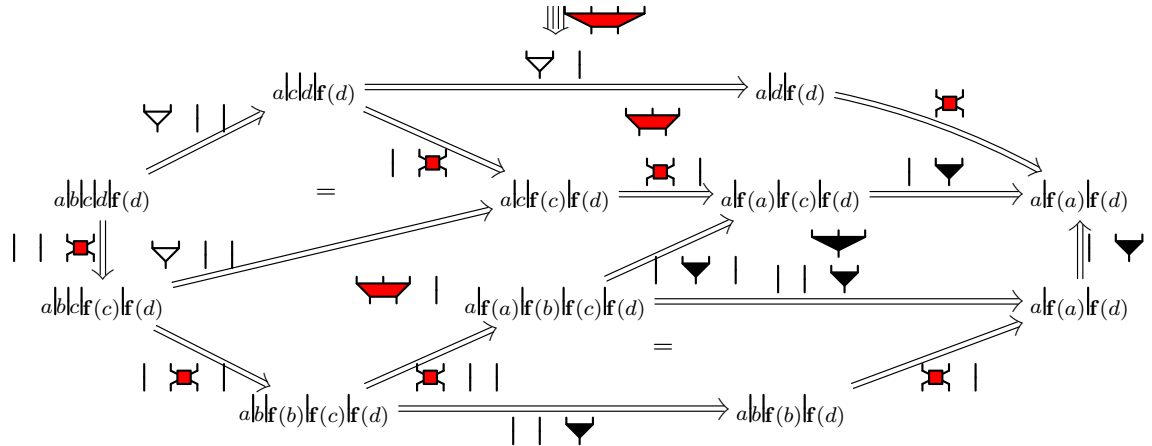
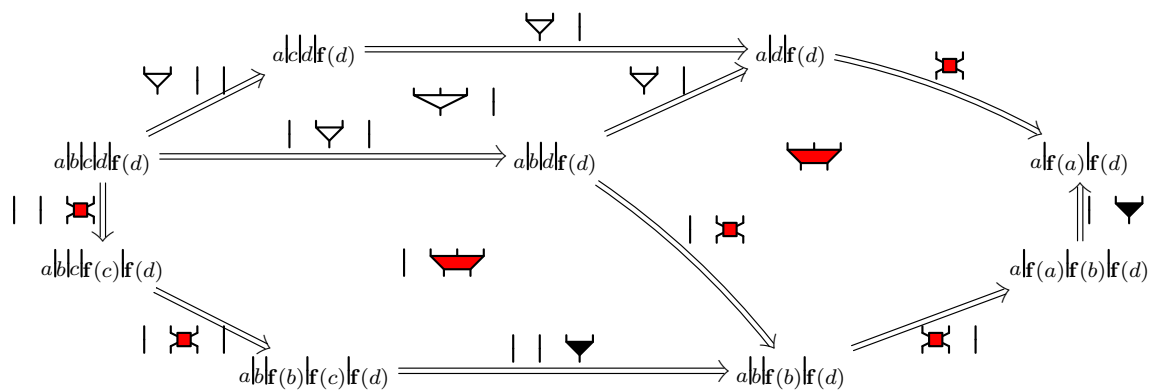

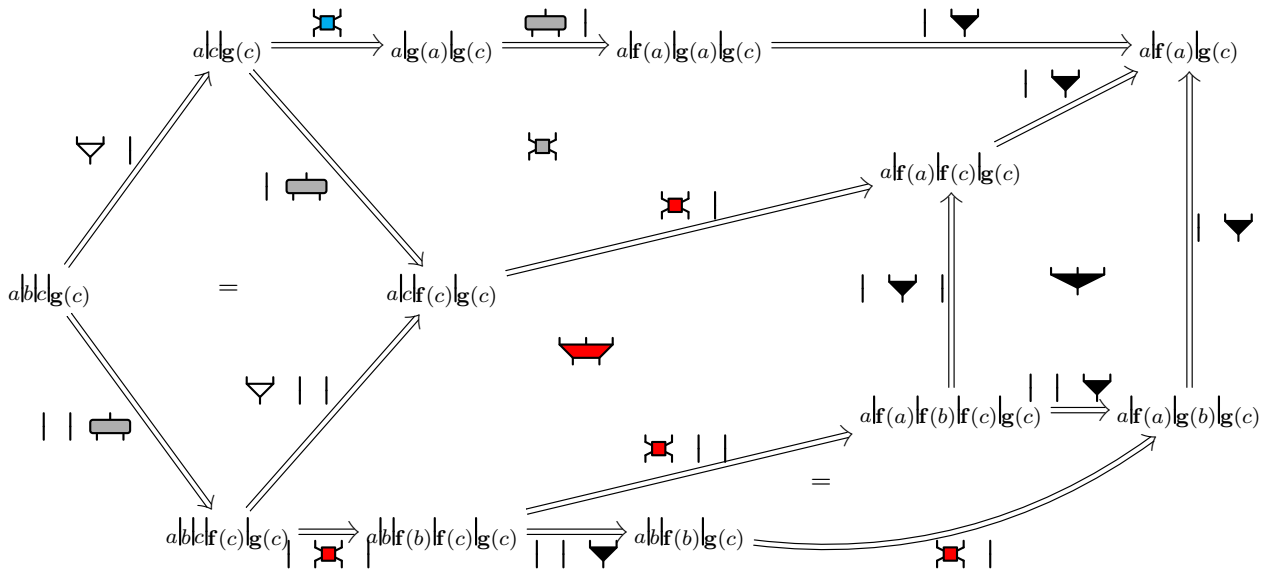
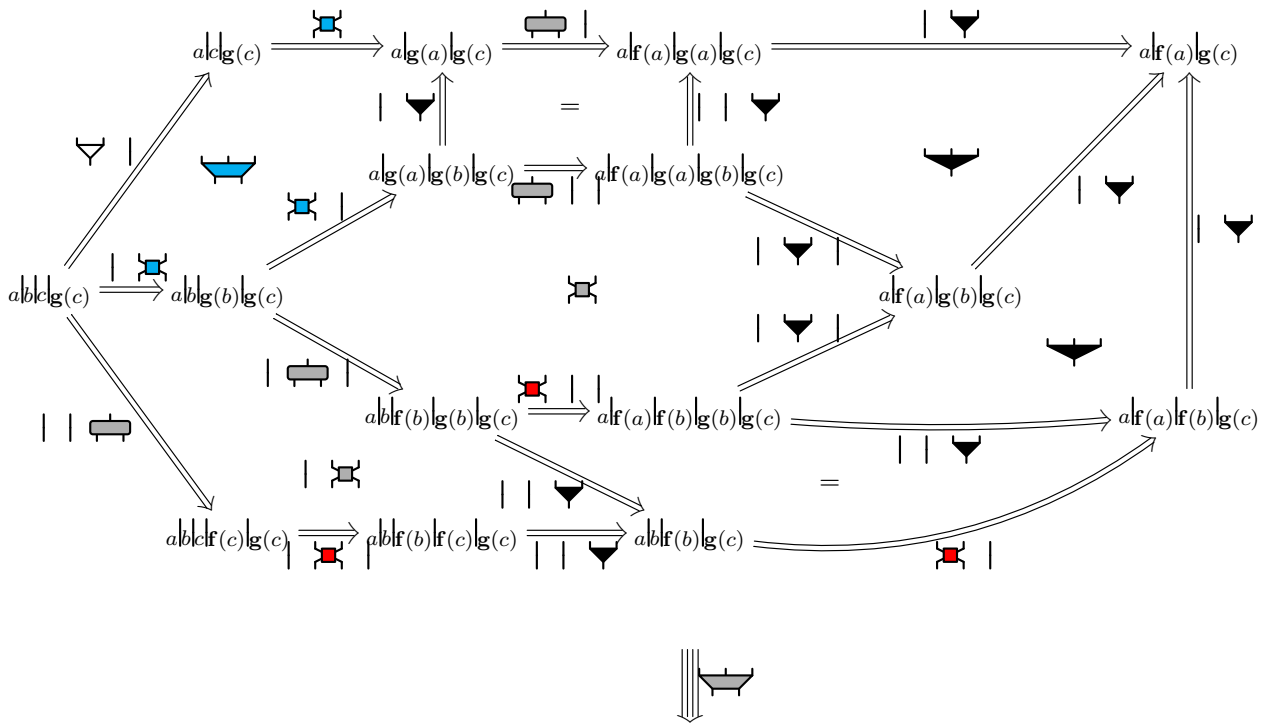

□

Proposition 3.1.3.7. For every 3-cells $A, B \in \mathbf{PNTrans}^{++}[\mathbf{f}, \mathbf{g}]^{*(2)}$ whose 1-target is of the form $a|_{\mathbf{f}(a)}b$, there exists a 4-cell $\alpha : A \rightrightarrows B \in \mathbf{PNTrans}[\mathbf{f}, \mathbf{g}]^{*(2)}$.

Proof. Thanks to Lemma 3.1.3.6, we can apply Theorem 3.1.3.5 to $\mathbf{PNTrans}^{++}[\mathbf{f}, \mathbf{g}]^{*(2)}$, and there exists a 4-cell $\alpha : A \rightrightarrows B$ in $\mathbf{PNTrans}^{++}[\mathbf{f}, \mathbf{g}]^{*(2)}$ for every 3-cells $A, B \in \mathbf{PNTrans}^{++}[\mathbf{f}, \mathbf{g}]^{*(2)}$ whose 1-target is a normal form. In particular the 1-cells of the form $a|_{\mathbf{f}(a)}b$ are normal forms. □

3.1.4 Adjunction of the units 2-cells

Definition 3.1.4.1. Let $\mathbf{PNTrans}^u[\mathbf{f}, \mathbf{g}]$ be the sub-3-polygraph of $\mathbf{PNTrans}[\mathbf{f}, \mathbf{g}]$ containing the same 1- and 2-cells, and whose only 3-cells are the unit cells from Table 3.2.

A 2-cell $h \in \mathbf{PNTrans}[\mathbf{f}, \mathbf{g}]_2^*$ is said *unitary* if it is generated by the sub-2-polygraph of $\mathbf{PNTrans}[\mathbf{f}, \mathbf{g}]$ whose only 2-cells are \circlearrowleft and \bullet .

Lemma 3.1.4.2. Let $h \in \mathbf{PNTrans}[\mathbf{f}, \mathbf{g}]_2^*$ whose target is of the form $a|_{\mathbf{f}(a)}|_b$, where $a \in \mathbf{C}$ and $b \in \mathbf{D}$.

If there is a decomposition $h = h_1 \bullet_1 h_2$, where $h_1 \in \mathbf{PNTrans}^u[\mathbf{f}, \mathbf{g}]^*$ and $h_2 \in \mathbf{PNTrans}[\mathbf{f}, \mathbf{g}]^*$ are not identities, and h_1 is a unitary 2-cell, then there is a 3-cell $A \in \mathbf{PNTrans}^u[\mathbf{f}, \mathbf{g}]_3^*$ of source h which is not an identity.

Proof. Let us start with the case where h_1 is of length 1. We reason by induction on the length of h_2 . If h_2 is of length 1, since the target of h_2 is of the form $a|_{\mathbf{f}(a)}|_b$, h_2 is one of the following 2-cells:



Hence, h is one of the following 2-cells:



And all of these 2-cells are indeed the sources of 3-cells in $\mathbf{PNTrans}^u[\mathbf{f}, \mathbf{g}]_3^*$.

In the general case, let us write $h_2 = h_0 \bullet_1 h'_2$, where h_0 is of length 1. Two cases can occur.

- If there exist 1-cells u, u', v and v' and 2-cells $h'_0 : u \Rightarrow u' \in \mathbf{PNTrans}^u[\mathbf{f}, \mathbf{g}]^*$ and $h'_1 : v \Rightarrow v' \in \mathbf{PNTrans}[\mathbf{f}, \mathbf{g}]^*$ such that $h_1 = h'_1 \bullet_0 u$ (resp. $h_1 = u \bullet_0 h'_1$) and $h_0 = v' \bullet_0 h'_0$ (resp. $h_0 = h'_0 \bullet_0 v'$).

Then $h = (h'_1 \bullet_0 h'_0) \bullet_1 h'_2$ (resp. $h = (h'_0 \bullet_0 h'_1) \bullet_1 h'_2$), and we can apply the induction hypothesis to $(h'_1 \bullet_0 u) \bullet_1 h'_2$ (resp. $(u' \bullet_0 h'_1) \bullet_1 h'_2$).

- Otherwise, $h_1 \bullet_1 h_0$ is one of the following 2-cells,



and all of them are sources of 3-cells in $\mathbf{PNTrans}^u[\mathbf{f}, \mathbf{g}]^*$.

In the case general case where h_1 is of any length, let $h'_1, h''_1 \in \mathbf{PNTrans}[\mathbf{f}, \mathbf{g}]_2^*$ with h''_1 of length 1 such that $h_1 = h'_1 \bullet_1 h''_1$. Then there is a non-empty 3-cell $A' \in \mathbf{PNTrans}^u[\mathbf{f}, \mathbf{g}]_3^*$ of source $h''_1 \bullet_1 h_2$, and one can take the 3-cell $h'_1 \bullet_1 A'$. \square

Lemma 3.1.4.3. Let h be a 2-cell in $\mathbf{PNTrans}[\mathbf{f}, \mathbf{g}]^*$ whose target is of the form $a|_{\mathbf{f}(a)}|_b$, with $a \in \mathbf{C}$ and $b \in \mathbf{D}$.

If h is a normal form for $\mathbf{PNTrans}^u[\mathbf{f}, \mathbf{g}]$, then one of the following holds:

- The 2-cell h equals the composite $| \bullet$.
- The 2-cell h is in $\mathbf{PNTrans}^{++}[\mathbf{f}, \mathbf{g}]^*$.

Proof. We reason by induction on the length of h . If h is of length 1, the cells of $\mathbf{PNTrans}[\mathbf{f}, \mathbf{g}]_2^*$ of length 1 and of target $a|_{\mathbf{f}(a)}|_b$ are:



Otherwise, let us write $h = h_1 \bullet_1 h_2$, where h_1 is of length 1. We can apply the induction hypothesis to h_2 , which leads us to distinguish three cases:

- If $h_2 = | \blacklozenge$, then h_1 is a 2-cell in $\mathbf{PNTrans}[\mathbf{f}, \mathbf{g}]_2^*$ whose target is of the form $a|_{\mathbf{f}(a)}$. The only such cell is the identity, and $h = h_2 = | \blacklozenge$.
- If h_1 and h_2 are in $\mathbf{PNTrans}^{++}[\mathbf{f}, \mathbf{g}]^*$, then h is in $\mathbf{PNTrans}^{++}[\mathbf{f}, \mathbf{g}]^*$.
- Lastly, if h_2 is in $\mathbf{PNTrans}^{++}[\mathbf{f}, \mathbf{g}]^*$ and h_1 is in $\mathbf{PNTrans}^u[\mathbf{f}, \mathbf{g}]^*$, then because of Lemma 3.1.4.2, h is the source of a 3-cell in $\mathbf{PNTrans}^u[\mathbf{f}, \mathbf{g}]^*$ of length 1, which is impossible since, by hypothesis, h is a normal form for $\mathbf{PNTrans}^u[\mathbf{f}, \mathbf{g}]$.

□

Definition 3.1.4.4. Let $\mathbf{PNTrans}^+[\mathbf{f}, \mathbf{g}]$ be the sub-4-polygraph of $\mathbf{PNTrans}[\mathbf{f}, \mathbf{g}]$ containing $\mathbf{PNTrans}^{++}[\mathbf{f}, \mathbf{g}]$, together with the 2-cells φ and \blacklozenge .

In particular a 3-cell in the free (3, 2)-category $\mathbf{PNTrans}^+[\mathbf{f}, \mathbf{g}]^{*(2)}$ is in $\mathbf{PNTrans}^{++}[\mathbf{f}, \mathbf{g}]^{*(2)}$ if and only if its 2-source is in $\mathbf{PNTrans}^{++}[\mathbf{f}, \mathbf{g}]^{*(2)}$ too.

Proposition 3.1.4.5. For every parallel 3-cells $A, B \in \mathbf{PNTrans}^+[\mathbf{f}, \mathbf{g}]^{*(2)}$ whose 1-target is of the form $a|_{\mathbf{f}(a)}|_b$ and whose 2-source is a normal form for $\mathbf{PNTrans}^u[\mathbf{f}, \mathbf{g}]$, there exists a 4-cell $\alpha : A \Rrightarrow B \in \mathbf{PNTrans}[\mathbf{f}, \mathbf{g}]^{*(2)}$.

Proof. Given such 3-cells A and B , we use Lemma 3.1.4.3 to distinguish two cases:

If the source of A and B is $| \blacklozenge$, the only 3-cell in $\mathbf{PNTrans}^+[\mathbf{f}, \mathbf{g}]^{*(2)}$ with source $| \blacklozenge$ is the identity. So $A = B$ and we can take $\alpha = 1_A$.

Otherwise, the source of A and B lies in $\mathbf{PNTrans}^{++}[\mathbf{f}, \mathbf{g}]_2^*$, so A and B lie in $\mathbf{PNTrans}^{++}[\mathbf{f}, \mathbf{g}]_3^{*(2)}$. Proposition 3.1.3.7 allows us to conclude. □

3.1.5 Adjunction of the units 3-cells

In this section, we consider the rewriting system formed by the 3-cells of $\mathbf{PNTrans}^u[\mathbf{f}, \mathbf{g}]$. Since it is a sub-3-polygraph of $\mathbf{PNTrans}[\mathbf{f}, \mathbf{g}]$ (which 3-terminates by Proposition 3.1.1.6), $\mathbf{PNTrans}^u[\mathbf{f}, \mathbf{g}]$ is 3-terminating. The fact that it is 3-confluent is a consequence of the following more general Lemma:

Lemma 3.1.5.1. Let $A \in \mathbf{PNTrans}[\mathbf{f}, \mathbf{g}]_3^*$ and $B \in \mathbf{PNTrans}^u[\mathbf{f}, \mathbf{g}]_3^*$. There exist 3-cells $A' \in \mathbf{PNTrans}[\mathbf{f}, \mathbf{g}]_3^*$ and $B' \in \mathbf{PNTrans}^u[\mathbf{f}, \mathbf{g}]^*$ and a 4-cell $\alpha_{A,B} \in \mathbf{PNTrans}[\mathbf{f}, \mathbf{g}]_4^{*(2)}$ of the following shape:

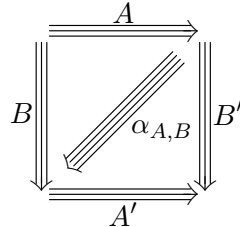

Proof. Let us start by the case where (A, B) is a critical pair of $\mathbf{PNTrans}[\mathbf{f}, \mathbf{g}]_3$. If A and B are in $\mathbf{PFonct}[\mathbf{f}, \mathbf{g}]_3^*$, the result holds because $\mathbf{PFonct}[\mathbf{f}, \mathbf{g}]$ is 3-convergent. Otherwise, the only critical pair left is the following one:

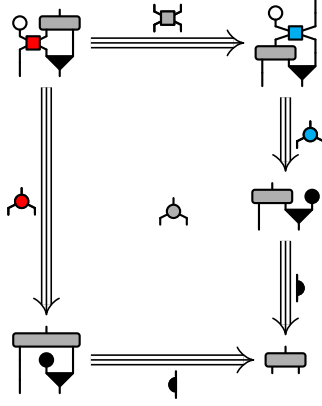

Let us now study the case where (A, B) is a local branching of $\mathbf{PNTrans}[\mathbf{f}, \mathbf{g}]_3$. We distinguish three cases depending on the shape of the branching:

- If (A, B) is an aspherical branching, then one can take identities for A' and B' , and $\alpha = 1_A$.
- If (A, B) is a Peiffer branching, let A' and B' be the canonical fillers of the confluence diagram of (A, B) , and α be an identity.
- Lastly, if (A, B) is an overlapping branching, let us write $(A, B) = (f \bullet_1 uA_1v \bullet_1 g, f \bullet_1 uB_1v \bullet_1 g)$, where (A_1, B_1) is a critical pair. Let A'_1, B'_1 and α_1 be the cells associated with (A_1, B_1) . We then define $A' := f \bullet_1 uA'_1v \bullet_1 g$, $B' := f \bullet_1 uB'_1v \bullet_1 g$ and $\alpha_1 := f \bullet_1 u\alpha_1v \bullet_1 g$.

In the general case, we reason by noetherian induction on $h = s(A) = s(B)$, using the 3-termination of $\mathbf{PNTrans}[\mathbf{f}, \mathbf{g}]$.

- If A or B is an identity, then the result holds immediately.
- Otherwise, we write $A = A_1 \bullet_2 A_2$ and $B = B_1 \bullet_2 B_2$, where A_1 and B_1 are of length 1. We now build the following diagram:

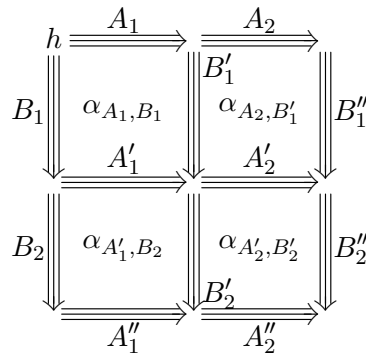

In this diagram, α_{A_1, B_1} is obtained thanks to our study of the local branchings. The existence of α_{A_2, B'_1} and $\alpha_{A'_1, B_2}$ (followed by $\alpha_{A'_2, B'_2}$) then follows from the induction hypothesis. \square

Lemma 3.1.5.2. *Let f, g be 2-cells of $\mathbf{PNTrans}[\mathbf{f}, \mathbf{g}]^*$, and $A : f \Rightarrow g$ a 3-cell of $\mathbf{PNTrans}^+[\mathbf{f}, \mathbf{g}]^*$. If f is a normal form for $\mathbf{PNTrans}^u[\mathbf{f}, \mathbf{g}]$, then so is g .*

Proof. We prove this result by contrapositive. We are going to show that for any $A \in \mathbf{PNTrans}^+[\mathbf{f}, \mathbf{g}]^*$ and $B \in \mathbf{PNTrans}^u[\mathbf{f}, \mathbf{g}]^*$ two 3-cells of length 1 such that $t(A) = s(B)$, there exists $B' \in \mathbf{PNTrans}^u[\mathbf{f}, \mathbf{g}]^*$ of length 1 and of source $s(A)$:

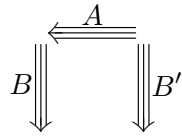

Two cases can occur depending on the shape of the branching (A^{-1}, B) :

- If it is a Peiffer branching, then the required cell is provided by the canonical filling.
- If it is an overlapping branching, then it is enough to check the underlying critical pair.

It remains to examine those critical pairs:

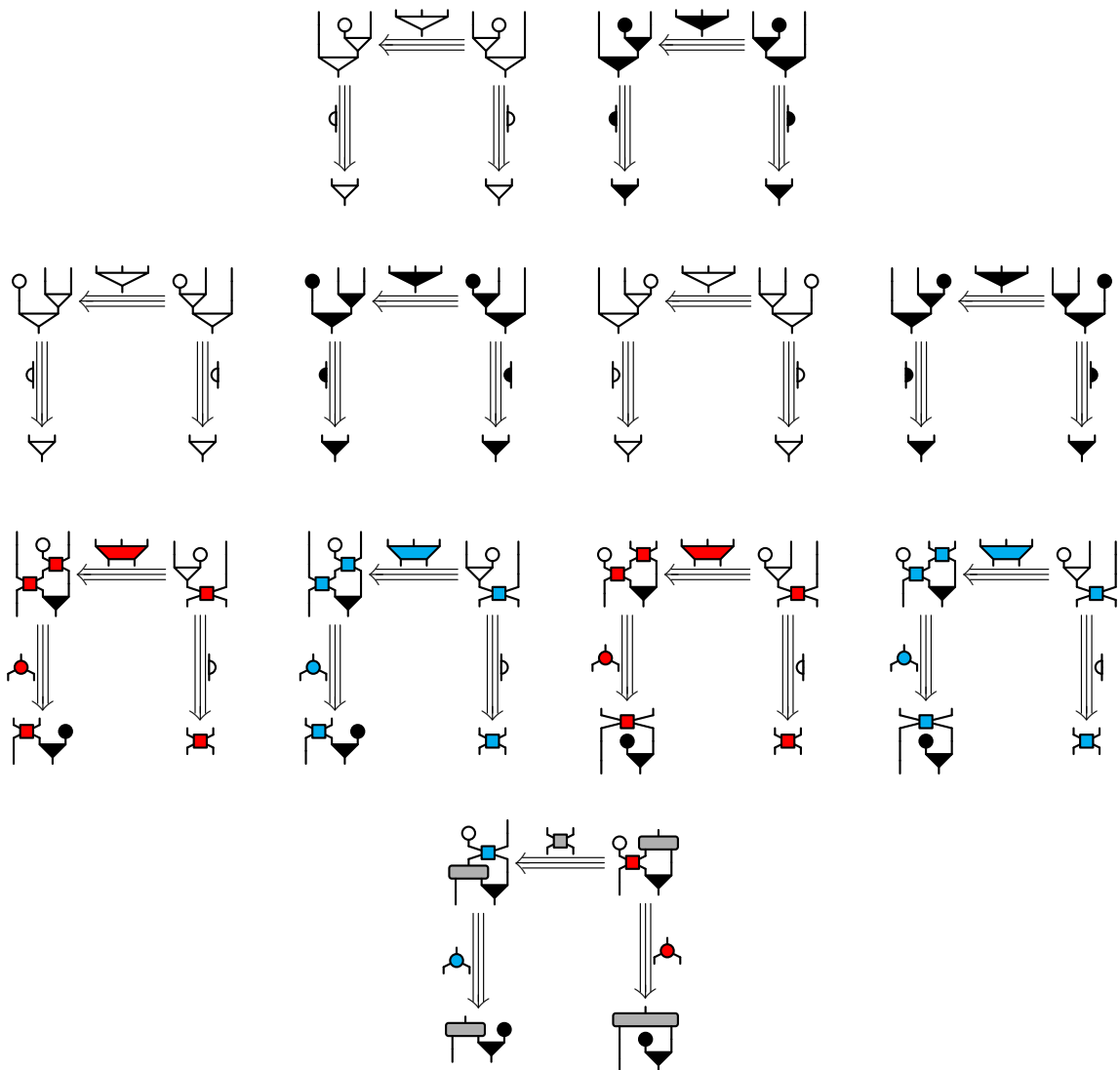

□

Lemma 3.1.5.3. *Let $A \in \mathbf{PNTrans}[\mathbf{f}, \mathbf{g}]_3^*$. If the source of A is a formal form for $\mathbf{PNTrans}^u[\mathbf{f}, \mathbf{g}]$, then A is in $\mathbf{PNTrans}^+[\mathbf{f}, \mathbf{g}]_3^*$.*

Proof. We reason by induction on the length of A :

- If A is an identity, then it is in $\mathbf{PNTrans}^+[\mathbf{f}, \mathbf{g}]$.
- Otherwise, let us write $A = A_1 \bullet_2 A_2$, where A_1 is of length 1. Since the source of A is a normal form for $\mathbf{PNTrans}^u[\mathbf{f}, \mathbf{g}]$, the 3-cell A_1 can only be in $\mathbf{PNTrans}^+[\mathbf{f}, \mathbf{g}]^*$.

According to Lemma 3.1.5.2, the normal forms for $\mathbf{PNTrans}^u[\mathbf{f}, \mathbf{g}]$ are stable when rewritten by $\mathbf{PNTrans}^+[\mathbf{f}, \mathbf{g}]^*$. Hence, the source A_2 is a normal form for $\mathbf{PNTrans}^u[\mathbf{f}, \mathbf{g}]$, and by induction hypothesis, A_2 is in $\mathbf{PNTrans}^+[\mathbf{f}, \mathbf{g}]^*$. By composition, so is A .

□

Lemma 3.1.5.4. *Let A be a 3-cell in $\mathbf{PNTrans}[\mathbf{f}, \mathbf{g}]^{*(2)}$. There exist $C_1, C_2 \in \mathbf{PNTrans}^u[\mathbf{f}, \mathbf{g}]_3^*$ whose target is a normal form for $\mathbf{PNTrans}^u[\mathbf{f}, \mathbf{g}]$, a 3-cell $A' \in \mathbf{PNTrans}^+[\mathbf{f}, \mathbf{g}]_3^{*(2)}$ and a 4-cell $\alpha \in \mathbf{PNTrans}[\mathbf{f}, \mathbf{g}]_4^{*(2)}$ of the following shape:*

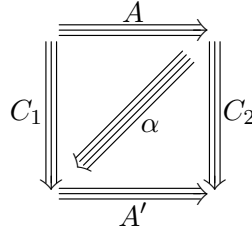

Proof. Let us write $A = A_1^{-1} \bullet_2 B_1 \bullet_2 A_2^{-1} \dots \bullet_2 A_n^{-1} \bullet_2 B_n$, where the A_i and B_i are in $\mathbf{PNTrans}[\mathbf{f}, \mathbf{g}]_3^*$. For every $i \leq n$, we chose a 3-cell $D_i \in \mathbf{PNTrans}^u[\mathbf{f}, \mathbf{g}]_3^*$ of source $s(A_i) = s(B_i)$ and of target a normal form for $\mathbf{PNTrans}^u[\mathbf{f}, \mathbf{g}]$.

According to Lemma 3.1.5.1, there exist for every i some 3-cells A'_i, B'_i in $\mathbf{PNTrans}[\mathbf{f}, \mathbf{g}]^*$, $D'_i \in \mathbf{PNTrans}^u[\mathbf{f}, \mathbf{g}]_3^*$ and $D''_i \in \mathbf{PNTrans}^u[\mathbf{f}, \mathbf{g}]_3^*$ and some 4-cells α_i and β_i in $\mathbf{PNTrans}[\mathbf{f}, \mathbf{g}]^{*(2)}$ of the form:

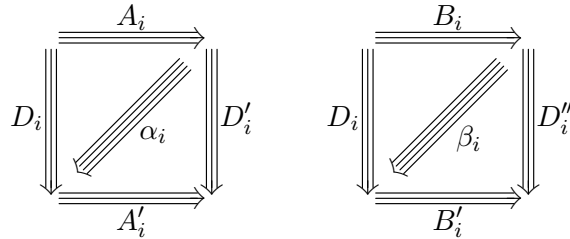

The following is a consequence of the target of D_i being a normal form for $\mathbf{PNTrans}^u[\mathbf{f}, \mathbf{g}]$:

- Using Lemma 3.1.5.3, A'_i and B'_i are in $\mathbf{PNTrans}^+[\mathbf{f}, \mathbf{g}]^*$,
- Using Lemma 3.1.5.2, the target A'_i and B'_i (thus of D'_i and D''_i) are normal forms for $\mathbf{PNTrans}^u[\mathbf{f}, \mathbf{g}]$.
- Since $\mathbf{PNTrans}^u[\mathbf{f}, \mathbf{g}]$ is 3-convergent, for any $i < n$, the cells D''_i and D'_{i+1} are parallel.

Since $\mathbf{PNTrans}^u[\mathbf{f}, \mathbf{g}]$ is a sub-polygraph of $\mathbf{PFonct}[\mathbf{f}, \mathbf{g}]$ which is 3-coherent, there exists, for every $i < n$, a 4-cell $\gamma_i : D''_i \Rrightarrow D'_i$ in $\mathbf{PFonct}[\mathbf{f}, \mathbf{g}]_4^{*(2)}$.

We can now conclude the proof of this Lemma by taking $C_1 = D'_1$, $C_2 = D''_n$ and $A' = (A'_1)^{-1} \bullet_2 B'_2 \bullet_2 \dots \bullet_2 (A'_n)^{-1} \bullet_2 B'_n$, and by defining α as the following composite:

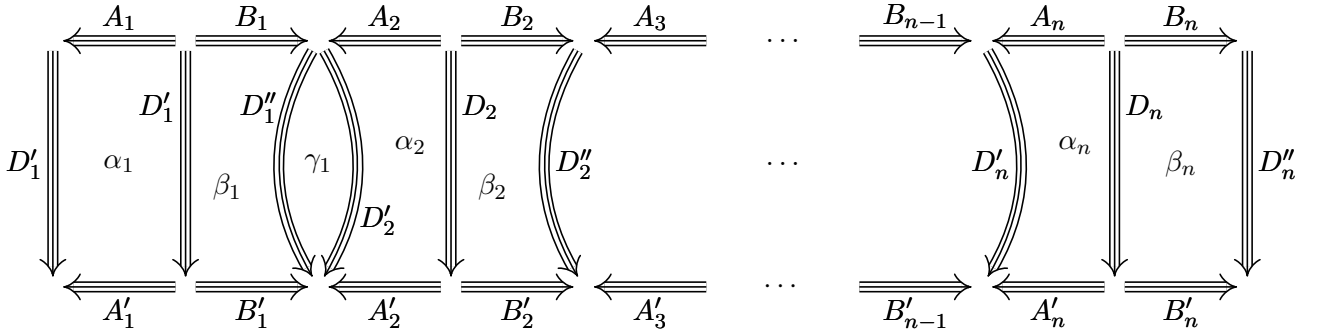

□

We can now conclude the proof Theorem 3.1.1.8.

Theorem 3.1.1.8 (Coherence for pseudonatural transformations). *Let \mathbf{C} and \mathbf{D} be sets, and $\mathbf{f}, \mathbf{g} : \mathbf{C} \rightarrow \mathbf{D}$ applications.*

Let $A, B \in \mathbf{PNTrans}[\mathbf{f}, \mathbf{g}]_3^{(2)}$ be two parallel 3-cells whose 1-target is of weight 1.*

There is a 4-cell $\alpha : A \rightrightarrows B \in \mathbf{PNTrans}[\mathbf{f}, \mathbf{g}]_4^{(2)}$.*

Proof. Let $A, B \in \mathbf{PNTrans}[\mathbf{f}, \mathbf{g}]_3^{*(2)}$ be two parallel 3-cells whose 1-target is $a|_{\mathbf{f}(a)}|_b$. We are going to build a 4-cell $\alpha : A \rightrightarrows B \in \mathbf{PNTrans}[\mathbf{f}, \mathbf{g}]_4^{*(2)}$.

According to Lemma 3.1.5.4, there exist $C_1, C_2, C'_1, C'_2 \in \mathbf{PNTrans}^u[\mathbf{f}, \mathbf{g}]^*$ whose targets are normal forms for $\mathbf{PNTrans}^u[\mathbf{f}, \mathbf{g}]$, $A', B' \in \mathbf{PNTrans}^+[\mathbf{f}, \mathbf{g}]^{*(2)}$ and $\alpha_1, \alpha_2 \in \mathbf{TPN}[\mathbf{f}, \mathbf{g}]_4^{*(2)}$ such that we have the diagrams:

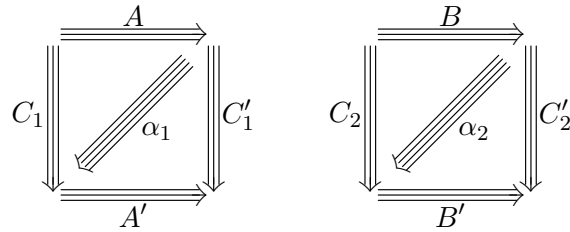

The 3-cells A and B are parallel, and the 3-cells C_1 and C_2 (resp. C'_1 and C'_2) have the same source and have a normal form for $\mathbf{PNTrans}^u[\mathbf{f}, \mathbf{g}]$ as target. Since $\mathbf{PNTrans}^u[\mathbf{f}, \mathbf{g}]$ is 3-convergent, this implies that the 3-cells C_1 and C_2 (resp. C'_1 and C'_2) are parallel. This has two consequences:

- The critical pairs of $\mathbf{PNTrans}^u[\mathbf{f}, \mathbf{g}]$ already appeared in $\mathbf{PFonct}[\mathbf{f}, \mathbf{g}]$, and we showed that they admit fillers. Hence, there exist cells $\beta_1 : C_1 \rightrightarrows C_2$ and $\beta_2 : C'_1 \rightrightarrows C'_2$ in $\mathbf{PNTrans}[\mathbf{f}, \mathbf{g}]_4^{*(2)}$.
- The 3-cells A' and B' are parallel, their 1-target is still $a|_{\mathbf{f}(a)}|_b$, and their 2-source is a normal form for $\mathbf{PNTrans}^u[\mathbf{f}, \mathbf{g}]$. So by Proposition 3.1.4.5 there exists a 4-cell $\gamma : A' \rightrightarrows B'$.

To conclude, we define α as the following composite (where we omit the context of the 4-cells):

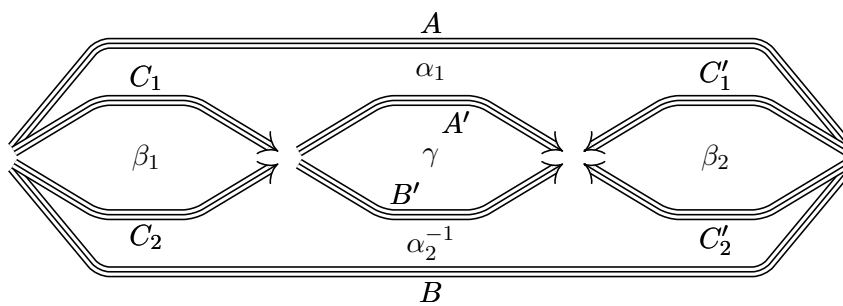

3.2 Partial coherence and transformation of polygraphs

This section contains some preliminary results that will be used in Sections 3.3 and 3.4 to prove Theorem 3.1.3.5. In Section 3.2.1, we define the notion of white category together with the associated notion of white polygraph. The white 2-categories are also known as *sesquicategories* (see [80]). White categories are strict categories in which the interchange law between the compositions \bullet_0 and \bullet_i need not hold, for every $i > 0$. That is, strict n -categories are exactly the white n -categories satisfying the additional condition that for every i -cells f and g of 1-sources (resp. 1-targets) u and v (resp. u' and v'): $(f \bullet_0 v) \bullet_i (u' \bullet_0 g) = (u \bullet_0 g) \bullet_i (f \bullet_0 v)$.

In Section 3.2.2, we define a notion of partial coherence for white $(4, 3)$ -categories, and reformulate Theorem 3.1.3.5 using this notion. We show a simple criterion in order to deduce the partial coherence of a white $(4, 3)$ -category from that of another one. This criterion will be used throughout Section 3.3. We also adapt the notion of Tietze-transformation from [31] to our setting of partial coherence in white categories, in preparation for Section 3.3.5.

In Section 3.2.3, we study injective functors between free white categories. In particular, we give a sufficient condition for a morphism of white polygraphs to yield an injective functor between the white categories they generate. This result will be used in Section 3.3.3.

Note that, although Sections 3.2.2 and 3.2.3 are expressed in terms of white categories (since this is how they will be used throughout Section 3.3), all the definitions and results in these sections also hold in terms of strict categories, *mutatis mutandis*.

3.2.1 White categories and white polygraphs

Definition 3.2.1.1. Let $n \in \mathbb{N}$. An $(n + 1)$ -white-category is given by:

- a set \mathcal{C}_0 ,
- for every $x, y \in \mathcal{C}_0$, an n -category $\mathcal{C}(x, y)$. We denote by \bullet_{k+1} the k -composition in this category,
- for every $z \in \mathcal{C}_0$ and every $u : x \rightarrow y \in \mathcal{C}_1$, functors $u \bullet_0 _ : \mathcal{C}(y, z) \rightarrow \mathcal{C}(x, z)$ and $_ \bullet_0 u : \mathcal{C}(z, x) \rightarrow \mathcal{C}(z, y)$, so that for every composable 1-cells $u, v \in \mathcal{C}_1$, their composite $u \bullet_0 v$ is uniquely defined,
- for every $x \in \mathcal{C}_0$, a 1-cell $1_x \in \mathcal{C}(x, x)$.

Moreover, this data must satisfy the following axioms:

- For every $x \in \mathcal{C}_0$, and every $y \in \mathcal{C}_0$, the functors $1_x \bullet_0 _ : \mathcal{C}(x, y) \rightarrow \mathcal{C}(x, y)$ and $_ \bullet_0 1_y : \mathcal{C}(x, y) \rightarrow \mathcal{C}(x, y)$ are identities.
- For every $u, v \in \mathcal{C}_1$, the following equalities hold:
 - $u \bullet_0 (v \bullet_0 _) = (u \bullet_0 v) \bullet_0 _$,
 - $u \bullet_0 (_ \bullet_0 v) = (u \bullet_0 _) \bullet_0 v$,
 - $_ \bullet_0 (u \bullet_0 v) = (_ \bullet_0 u) \bullet_0 v$,

An (n, k) -white-category is an n -white-category in which every $(i + 1)$ -cell is invertible for the i -composition, for every $i \geq k$.

Let n be a natural number. Let \mathcal{C} be an n -white-category. For $k \leq n$, we denote by \mathcal{C}_k both the set of k -cells of \mathcal{C} and the k -white-category obtained by deleting the cells of dimension greater than k . For $x \in \mathcal{C}_k$ and $i < k$, we denote by $s_i(x)$ and $t_i(x)$ respectively the i -source and i -target of x . Finally, we write $s(x)$ and $t(x)$ respectively for $s_{k-1}(x)$ and $t_{k-1}(x)$.

Definition 3.2.1.2. Let \mathcal{C} and \mathcal{D} be n -white-categories. An n -white-functor is given by:

- an application $F_0 : \mathcal{C}_0 \rightarrow \mathcal{D}_0$,
- for every $x, y \in \mathcal{C}_0$, a functor $F_{x,y} : \mathcal{C}(x, y) \rightarrow \mathcal{D}(F_0(x), F_0(y))$.

Moreover, this data must satisfy the following axioms:

- for every $x \in \mathcal{C}_0$, $F(1_x) = 1_{F_0(x)}$,
- for every $z \in \mathcal{C}_0$ and $u : x \rightarrow y \in \mathcal{C}_1$, the following equalities hold between functors:
 - $F(u) \bullet_0 F(_) = F(u \bullet_0 _) : \mathcal{C}(y, z) \rightarrow \mathcal{D}(F_0(x), F_0(z))$
 - $F(_) \bullet_0 F(u) = F(_ \bullet_0 u) : \mathcal{C}(z, x) \rightarrow \mathcal{D}(F_0(z), F_0(y))$

This makes n -white-categories into a category, that we denote by \mathbf{WCat}_n .

Remark 3.2.1.3. Let us define a structure of monoidal category \otimes on n - \mathbf{Cat} , in such a way that \mathbf{WCat}_{n+1} is the category of categories enriched over $(n$ - $\mathbf{Cat}, \otimes)$.

Let \mathcal{C}, \mathcal{D} be two n -categories. The n -categories $\mathcal{C} \times \mathcal{D}_0$ and $\mathcal{C}_0 \times \mathcal{D}$ are defined as follows:

$$\mathcal{C} \times \mathcal{D}_0 := \bigsqcup_{y \in \mathcal{D}_0} \mathcal{C}, \quad \mathcal{C}_0 \times \mathcal{D} := \bigsqcup_{x \in \mathcal{C}_0} \mathcal{D}$$

Let $\mathcal{C}_0 \times \mathcal{D}_0$ be the n -category whose 0-cells are couples $(x, y) \in \mathcal{C}_0 \times \mathcal{D}_0$, and whose i -cells are identities for every $i > 0$. Let $F : \mathcal{C}_0 \times \mathcal{D}_0 \rightarrow \mathcal{C} \times \mathcal{D}_0$ (resp. $G : \mathcal{C}_0 \times \mathcal{D}_0 \rightarrow \mathcal{C}_0 \times \mathcal{D}$) be the n -functor which is the identity on 0-cells. Then $\mathcal{C} \otimes \mathcal{D}$ is the pushout $(\mathcal{C} \times \mathcal{D}_0) \oplus_{\mathcal{C}_0 \times \mathcal{D}_0} (\mathcal{C}_0 \times \mathcal{D})$:

$$\begin{array}{ccc} \mathcal{C}_0 \times \mathcal{D}_0 & \xrightarrow{F} & \mathcal{C} \times \mathcal{D}_0 \\ G \downarrow & \lrcorner & \downarrow \\ \mathcal{C}_0 \times \mathcal{D} & \longrightarrow & \mathcal{C} \otimes \mathcal{D}. \end{array}$$

The category of n -white-categories equipped with a cellular extension, denoted by \mathbf{WCat}_n^+ , is the limit of the following diagram:

$$\begin{array}{ccc} \mathbf{WCat}_n^+ & \longrightarrow & \mathbf{Graph}_{n+1} \\ \downarrow & \lrcorner & \downarrow \\ \mathbf{WCat}_n & \longrightarrow & \mathbf{Graph}_n \end{array}$$

where the functor $\mathbf{WCat}_n \rightarrow \mathbf{Graph}_n$ forgets the white-categorical structure and the functor $\mathbf{Graph}_{n+1} \rightarrow \mathbf{Graph}_n$ deletes the top-dimensional cells.

Let \mathcal{R}_n^w be the functor from \mathbf{WCat}_{n+1} to \mathbf{WCat}_n^+ that sends an $(n+1)$ -white-category \mathcal{C} on the couple $(\mathcal{C}_n, \mathcal{C}_n \xleftarrow{\quad} \mathcal{C}_{n+1})$.

Proposition 3.2.1.4. *The functor \mathcal{R}_n^w admits a left-adjoint $\mathcal{L}_n^w : \mathbf{WCat}_n^+ \rightarrow \mathbf{WCat}_{n+1}$.*

Proof. Let $(\mathcal{C}, \Sigma) \in \mathbf{WCat}_n^+$ be an n -white-category equipped with a cellular extension. The construction of $\mathcal{L}_n^w(\mathcal{C}, \Sigma)$ is split into three parts:

- First, we define a formal language E_Σ .

- Then, we define a typing system $T_{\mathcal{C}}$ on E_{Σ} . We denote by E_{Σ}^T the set of all typable expressions of E_{Σ} .
- Finally, we define an equivalence relation \equiv_{Σ}^* on E_{Σ}^T . The set of $(n+1)$ -cell of $\mathcal{L}_n^{\mathbf{w}}(\mathcal{C}, \Sigma)$ is then the quotient $E_{\Sigma}^T / \equiv_{\Sigma}^*$.

Let E_{Σ} be the formal language consisting of:

- For every 1-cells $u, v \in \mathcal{C}_1$, and every $(n+1)$ -cell $A \in \Sigma_{n+1}$, such that $t_0(u) = s_0(A)$ and $t_0(A) = s_0(v)$, a constant symbol c_{uAv} .
- For every n -cell $f \in \mathcal{C}_n$, a constant symbol i_f .
- For every $0 < i \leq n$, a binary function symbol \bullet_i .

Thus E_{Σ} is the smallest set of expressions containing the constant symbols and such that $e \bullet_i f \in \Sigma$ whenever $e, f \in E_{\Sigma}$.

Let $T_{\mathcal{C}}$ be the set of all n -spheres of \mathcal{C} , that is of couples (f, g) in \mathcal{C}_n such that $s(f) = s(g)$ and $t(f) = t(g)$. For $e \in E_{\Sigma}$ and $t \in T_{\mathcal{C}}$, we define $e : t$ (read as "e is of type t") as the smallest relation satisfying the following axioms:

- For every 1-cells u and v in \mathcal{C}_1 , and every $(n+1)$ -cell $A \in \Sigma$, such that $t_0(u) = s_0(A)$ and $t_0(A) = s_0(v)$

$$c_{uAv} : (u s(A)v, u t(A)v)$$

- For every n -cell $f \in \mathcal{C}_n$

$$i_f : (f, f)$$

- For every $e_1, e_2 \in E_{\Sigma}$ and $i < n$, if $e_1 : (s_1, t_1)$, $e_2 : (s_2, t_2)$ and $t_i(t_1) = s_i(s_2)$, then

$$e_1 \bullet_i e_2 : (s_1 \bullet_i s_2, t_1 \bullet_i t_2)$$

- For every $e_1, e_2 \in E_{\Sigma}$, if $e_1 : (s_1, t_1)$, $e_2 : (s_2, t_2)$ and $t_1 = s_2$, then

$$e_1 \bullet_n e_2 : (s_1, t_2)$$

An expression $e \in E_{\Sigma}$ is said to be *typable* if $e : (s, t)$ for some n -sphere $(s, t) \in T_{\mathcal{C}}$. Moreover, there is only one such n -sphere, so the operations $s(e) := s$ and $t(e) := t$ are well-defined. We denote by E_{Σ}^T be the set of all typable expressions.

Let \equiv_{Σ} be the symmetric relation generated by the following relations on E_{Σ}^T :

- For every $A, B, C, D \in E_{\Sigma}^T$, and every $i_1, i_2 \leq n$ non-zero distinct natural numbers,

$$(A \bullet_{i_1} B) \bullet_{i_2} (C \bullet_{i_1} D) \equiv_{\Sigma} (A \bullet_{i_2} C) \bullet_{i_1} (B \bullet_{i_2} D)$$

- For every $A, B, C \in E_{\Sigma}^T$, and every $0 < i \leq n$,

$$(A \bullet_i B) \bullet_i C \equiv_{\Sigma} A \bullet_i (B \bullet_i C)$$

- For every $A \in E_{\Sigma}^T$ and $f \in \mathcal{C}_n$:

$$i_f \bullet_n A \equiv_{\Sigma} A \quad A \bullet_n i_f \equiv_{\Sigma} A$$

- For every $f_1, f_2 \in \mathcal{C}_n$ and every $i < n$,

$$i_{f_1} \bullet_i i_{f_2} \equiv_{\Sigma} i_{f_1 \bullet_i f_2}$$

- For every $A, A', B \in E_{\Sigma}^T$ and every $0 < i \leq n$, if $A \equiv_{\Sigma} A'$, then

$$A \bullet_i B \equiv_{\Sigma} A' \bullet_i B$$

- For every $A, B, B' \in E_{\Sigma}^T$ and every $0 < i \leq n$, if $B \equiv_{\Sigma} B'$, then

$$A \bullet_i B \equiv_{\Sigma} A \bullet_i B'$$

Let \equiv_{Σ}^* be the reflexive closure of \equiv_{Σ} . The $(n+1)$ -cells of $\mathcal{L}_n^{\mathbf{w}}(\mathcal{C}, \Sigma)$ are given by the quotient $E_{\Sigma}^T / \equiv_{\Sigma}^*$. The i -composition is given by the one of E_{Σ}^T , and identities by i_f . \square

Definition 3.2.1.5. We now define by induction on n the category \mathbf{WPol}_n of n -white-polygraphs together with a functor $\mathcal{Q}_n^{\mathbf{w}} : \mathbf{WPol}_n \rightarrow \mathbf{WCat}_n$.

- The category \mathbf{WPol}_0 is the category of sets, and $\mathcal{Q}_0^{\mathbf{w}}$ is the identity functor.
- Assume $\mathcal{Q}_n^{\mathbf{w}} : \mathbf{WPol}_n \rightarrow \mathbf{WCat}_n$ defined. Then \mathbf{WPol}_{n+1} is the limit of the following diagram:

$$\begin{array}{ccc} \mathbf{WPol}_{n+1} & \longrightarrow & \mathbf{WCat}_n^+ \\ \downarrow & \lrcorner & \downarrow \\ \mathbf{WPol}_n & \xrightarrow{\mathcal{Q}_n^{\mathbf{w}}} & \mathbf{WCat}_n, \end{array}$$

and $\mathcal{Q}_{n+1}^{\mathbf{w}}$ is the composite

$$\mathbf{WPol}_{n+1} \longrightarrow \mathbf{WCat}_n^+ \xrightarrow{\mathcal{L}_n^{\mathbf{w}}} \mathbf{WCat}_{n+1}$$

Given an n -white-polygraph Σ , the n -white-category $\mathcal{Q}_n^{\mathbf{w}}(\Sigma)$ is denoted by $\Sigma^{\mathbf{w}}$ and is called *the free n -white-category generated by Σ* .

Definition 3.2.1.6. Let $\mathbf{WCat}_{n+1}^{\mathbf{w}(n)}$ be the category of $(n+1, n)$ -white-categories. Once again we have a functor $\mathcal{R}_n^{\mathbf{w}(n)} : \mathbf{WCat}_{n+1}^{\mathbf{w}(n)} \rightarrow \mathbf{WCat}_n^+$, and we are going to describe its left-adjoint $\mathcal{L}_{n+1}^{\mathbf{w}(n)}$. Let (\mathcal{C}, Σ) be an n -white-category together with a cellular extension. To construct $\mathcal{L}_{n+1}^{\mathbf{w}(n)}(\mathcal{C}, \Sigma)$, we adapt the construction of the free n -white-categories as follows:

- Let F_{Σ} be the formal language $E_{\Sigma \cup \bar{\Sigma}}$, where $\bar{\Sigma}$ consists of formal inverses to the elements of Σ (that is their source and targets are reversed).
- The type system is extended by setting, for every 1-cells u, v in \mathcal{C}_1 and every $(n+1)$ -cell $A \in \Sigma$ such that $t_0(u) = s_0(v)$ and $t_0(A) = s_0(A)$:

$$c_{u\bar{A}v} : (u t(A)v, u s(A)v).$$

We denote by F_{Σ}^T the set of all typable expressions for this new typing system.

- We extend \equiv_Σ into a relation denoted by \cong_Σ by adding the following relations:

$$c_{uAv} \bullet_n c_{u\bar{A}v} \cong_\Sigma i_{us(A)v} \quad c_{u\bar{A}v} \bullet_n c_{uAv} \cong_\Sigma i_{ut(A)v}$$

for every u, v in \mathcal{C}_1 and every $(n+1)$ -cell $A \in \Sigma$, such that $t_0(u) = s_0(A)$ and $t_0(A) = s_0(v)$.

We define categories $\mathbf{WPol}_n^{(k)}$ of (n, k) -white-polygraphs and functors $\mathcal{Q}_n^{\mathbf{w}(k)} : \mathbf{WPol}_n^{(k)} \rightarrow \mathbf{WCat}_n^{(k)}$ similarly to $\mathbf{Pol}_n^{(k)}$ and $\mathcal{Q}_n^{(k)}$.

Definition 3.2.1.7. Given an (n, k) -white-polygraph Σ , the (n, k) -white-category $\mathcal{Q}_n^{\mathbf{w}(k)}(\Sigma)$ is denoted by $\Sigma^{\mathbf{w}(k)}$ and is called *the free (n, k) -white-category generated by Σ* . For $j \leq n$, we denote by $\Sigma_j^{\mathbf{w}(k)}$ both the j -cells of $\Sigma^{\mathbf{w}(k)}$ and the (j, k) -category generated by Σ . Hence, an (n, k) -polygraph Σ consists of the following data:

$$\begin{array}{cccccccccccccccc}
\Sigma_0 & & \Sigma_1 & & \Sigma_2 & & (\dots) & & \Sigma_k & & \Sigma_{k+1} & & (\dots) & & \Sigma_n \\
\parallel & \swarrow & \downarrow & \swarrow & \downarrow & \swarrow & & \swarrow & \downarrow & \swarrow & \downarrow & \swarrow & & \swarrow & \\
\Sigma_0 & \xleftarrow{\quad} & \Sigma_1^{\mathbf{w}} & \xleftarrow{\quad} & \Sigma_2^{\mathbf{w}} & \xleftarrow{\quad} & (\dots) & \xleftarrow{\quad} & \Sigma_k^{\mathbf{w}} & \xleftarrow{\quad} & \Sigma_{k+1}^{\mathbf{w}(k)} & \xleftarrow{\quad} & (\dots) & &
\end{array}$$

3.2.2 Partial coherence in pointed white $(4, 3)$ -categories

Definition 3.2.2.1. A *pointed* white $(4, 3)$ -category is a couple (\mathcal{C}, S) , where \mathcal{C} is a white 4-category, and S is a subset of \mathcal{C}_2 .

Definition 3.2.2.2. Let (\mathcal{C}, S) be a pointed white $(4, 3)$ -category. The *restriction of \mathcal{C} to S* , denoted by $\mathcal{C} \upharpoonright S$, is the following $(2, 1)$ -category:

- its 0-cells are the 2-cells of \mathcal{C}_2 that lie in S ,
- its 1-cells are the 3-cells of \mathcal{C}_3 with source and target in S ,
- its 2-cells are the 4-cells of \mathcal{C}_4 with 2-source and 2-target in S ,
- its 0-composition and 1-composition are respectively induced by the compositions \bullet_2 and \bullet_3 of \mathcal{C} .

Definition 3.2.2.3. Let (\mathcal{C}, S) be a pointed white $(4, 3)$ -category. We say that \mathcal{C} is *S -coherent* if for every parallel 1-cells A, B in the $(2, 1)$ -category $\mathcal{C} \upharpoonright S$, there exists a 2-cell $\alpha : A \Rightarrow B \in \mathcal{C} \upharpoonright S$.

Example 3.2.2.4. Every white $(4, 3)$ -category is \emptyset -coherent. A white $(4, 3)$ -category \mathcal{C} is \mathcal{C}_2 -coherent if and only if it is 3-coherent.

Theorem 3.1.3.5. Let \mathcal{A} be a $(4, 2)$ -polygraph satisfying the 2-Squier condition of depth 2, and let $S_{\mathcal{A}}$ be the set of all 2-cells whose target is a normal form.

Then \mathcal{A} is $S_{\mathcal{A}}$ -coherent.

Definition 3.2.2.5. Let \mathcal{C} and \mathcal{D} be two 2-categories, $F : \mathcal{C} \rightarrow \mathcal{D}$ a 2-functor.

We say that F is *0-surjective* if the application $F : \mathcal{C}_0 \rightarrow \mathcal{D}_0$ is surjective.

Let $0 < k < 2$. We say that F is *k -surjective* if, for every $(k-1)$ -parallel cells $s, t \in \mathcal{C}_{k-1}$, the application $F : \mathcal{C}_k(s, t) \rightarrow \mathcal{D}_k(F(s), F(t))$ is surjective.

Definition 3.2.2.6. Let (\mathcal{C}, S) and (\mathcal{C}', S') be two pointed $(4, 3)$ -categories. We say that (\mathcal{C}', S') is *stronger* than (\mathcal{C}, S) if there is a functor $F : \mathcal{C}' \upharpoonright S' \rightarrow \mathcal{C} \upharpoonright S$ which is 0-surjective and 1-surjective.

Lemma 3.2.2.7. *Let (\mathcal{C}, S) , (\mathcal{C}', S') be two pointed white $(4, 3)$ -categories. If there exists a 2-functor $F : \mathcal{C}' \downarrow S' \rightarrow \mathcal{C} \downarrow S$ which is 0-surjective and 1-surjective, then (\mathcal{C}', S') is stronger than (\mathcal{C}, S) .*

Proof. The functor F induces a functor $\bar{F} : \overline{\mathcal{C}' \downarrow S'} \rightarrow \overline{\mathcal{C} \downarrow S}$. Since it is equal to F on objects, it is 0-surjective. On 1-cells \bar{F} is the composition of F with the canonical projection associated to the quotient, hence it is 1-surjective, and so (\mathcal{C}', S') is stronger than (\mathcal{C}, S) . \square

Lemma 3.2.2.8. *Let (\mathcal{C}, S) , (\mathcal{C}', S') be two pointed white $(4, 3)$ -categories, and assume (\mathcal{C}', S') is stronger than (\mathcal{C}, S) .*

If \mathcal{C}' is S' -coherent, then \mathcal{C} is S -coherent.

Proof. Let $F : \overline{\mathcal{C}' \downarrow S'} \rightarrow \overline{\mathcal{C} \downarrow S}$ be a functor that is 0-surjective and 1-surjective. Let $A, B : f \rightarrow g \in (\mathcal{C} \downarrow S)_1$ be parallel 1-cells, and \bar{A}, \bar{B} be their projections in $\overline{\mathcal{C} \downarrow S}$.

Since F is 0-surjective, there exists $f', g' \in (\mathcal{C}' \downarrow S')_0$ in the preimage of f and g under F . Since F is 1-surjective, there exists $A', B' \in (\mathcal{C}' \downarrow S')_1$ of source f' and of target g' such that $F(\bar{A}') = \bar{A}$ and $F(\bar{B}') = \bar{B}$.

Since $\mathcal{C}' \downarrow S'$ is 2-coherent, there exists $\alpha' : A' \Rightarrow B' \in (\mathcal{C}' \downarrow S')_2$. Thus, $\bar{A}' = \bar{B}'$ and $\bar{A} = \bar{B}$. Hence, there exists $\alpha : A \Rightarrow B \in \mathcal{C} \downarrow S$. This shows that $\mathcal{C} \downarrow S$ is 1-coherent, and therefore that \mathcal{C} is S -coherent. \square

We are going to define four families of Tietze-transformations on white $(4, 3)$ -polygraphs. Tietze transformations originates from combinatorial group theory [58], and was adapted for $(3, 1)$ -categories in [31], as a way to modify a $(3, 1)$ -polygraph without modifying the 2-categories it presents. In particular, they preserve the 2-coherence. Here we adapt these transformations to our setting of white $(4, 3)$ -polygraphs and show that they preserve the partial coherence. This will be used in Section 3.3.5. We fix a white 4-polygraph \mathcal{A} .

Definition 3.2.2.9. Let $A \in \mathcal{A}_3^{\mathbf{w}(3)}$. We define a white 4-polygraph $\mathcal{A}(A)$ by adding to \mathcal{A} a 3-cell B and a 4-cell α , whose sources and targets are given by:

- $s(B) = s(A)$,
- $t(B) = t(A)$,
- $s(\alpha) = A$,
- $t(\alpha) = B$.

The inclusion induces a functor between white $(4, 3)$ -categories $\iota_A : \mathcal{A}^{\mathbf{w}(3)} \rightarrow (\mathcal{A}(A))^{\mathbf{w}(3)}$. We call this operation the *adjunction of a 3-cell with its defining 4-cell*.

Definition 3.2.2.10. Let $\alpha \in \mathcal{A}_4$ and $A \in \mathcal{A}_3$ such that:

- $t(\alpha) = A$
- $s(\alpha) \in (\mathcal{A} \setminus \{t(\alpha)\})_3^{\mathbf{w}(3)}$.

The 4-cell α induces an application $\mathcal{A}_3 \rightarrow (\mathcal{A}_3 \setminus \{t(\alpha)\})^{\mathbf{w}(3)}$, by sending $t(\alpha)$ on $s(\alpha)$ and that is the identity on the other cells of \mathcal{A}_3 . This application extends into a 3-functor $\pi_\alpha : \mathcal{A}_3^{\mathbf{w}} \rightarrow (\mathcal{A}_3 \setminus \{t(\alpha)\})^{\mathbf{w}}$.

Let $\mathcal{A}/(A; \alpha)$ be the following white 4-polygraph:

$$\mathcal{A}_0 \begin{array}{c} \xleftarrow{s} \\ \xrightarrow{t} \end{array} \mathcal{A}_1^{\mathbf{w}(3)} \begin{array}{c} \xleftarrow{s} \\ \xrightarrow{t} \end{array} \mathcal{A}_2^{\mathbf{w}(3)} \begin{array}{c} \xleftarrow{s} \\ \xrightarrow{t} \end{array} (\mathcal{A}_3 \setminus \{t(\alpha)\})^{\mathbf{w}(3)} \begin{array}{c} \xleftarrow{\pi_\alpha \circ s} \\ \xrightarrow{\pi_\alpha \circ t} \end{array} \mathcal{A}_4 \setminus \{\alpha\}$$

Then π_α induces a functor $\mathcal{A}^{\mathbf{w}(3)} \rightarrow (\mathcal{A}/(A; \alpha))^{\mathbf{w}(3)}$, which sends α on the identity of $s(\alpha)$, and which is the identity on the other cells of \mathcal{A}_4 . We call this operation the *removal of a 3-cell with its defining 4-cell*.

Definition 3.2.2.11. Let α be a 4-cell in $\mathcal{A}_4^{\mathbf{w}(3)}$. We define a white 4-polygraph $\mathcal{A}(\alpha)$ by adding to \mathcal{A} a 4-cell $\beta : s(\alpha) \Rrightarrow t(\alpha)$. The inclusion of \mathcal{A} into $\mathcal{A}(\alpha)$ induces a functor $\iota_\alpha : \mathcal{A}^{\mathbf{w}(3)} \rightarrow \mathcal{A}(\alpha)^{\mathbf{w}(3)}$. We call this operation the *adjunction of a superfluous 4-cell*.

Definition 3.2.2.12. Let $\beta \in \mathcal{A}_4$ such that there exists a 4-cell $\alpha \in (\mathcal{A} \setminus \{\beta\})^{\mathbf{w}(3)}$ parallel to β . Let \mathcal{A}/β be the white 4-polygraph obtained by removing β from \mathcal{A} . There exists a functor $\pi_\beta : \mathcal{A}^{\mathbf{w}(3)} \rightarrow (\mathcal{A}/\beta)^{\mathbf{w}(3)}$, that sends β on α and which is the identity on the other cells of \mathcal{A} . We call this operation the *removal of a superfluous 4-cell*.

Remark 3.2.2.13. Note that, in those four cases, the set of 2-cells is left unchanged. In particular, let \mathcal{A} be a white 4-polygraph, and \mathcal{B} a white 4-polygraph constructed from \mathcal{A} through a series of Tietze-transformations. If S is a sub-set of $\mathcal{A}_2^{\mathbf{w}}$, then S still is a subset of $\mathcal{B}_2^{\mathbf{w}}$.

Proposition 3.2.2.14. Let \mathcal{A} be a white 4-polygraph, S a sub-set of $\mathcal{A}_2^{\mathbf{w}}$, and \mathcal{B} a white 4-polygraph constructed from \mathcal{A} through a series of Tietze-transformations.

If $\mathcal{B}^{\mathbf{w}(3)}$ is S -coherent, then $\mathcal{A}^{\mathbf{w}(3)}$ is S -coherent.

Proof. We check that if \mathcal{B} is constructed from \mathcal{A} through a Tietze-transformation, then the white 3-categories presented by \mathcal{A} and \mathcal{B} are isomorphic.

Suppose now that \mathcal{B} is S -coherent, and let $A, B \in \mathcal{A}_3^{\mathbf{w}}$ be parallel 3-cells, whose source and target are in S . Since $\mathcal{B}^{\mathbf{w}(3)}$ is S -coherent, the images of A and B in the white 3-category presented by \mathcal{B} are equal. Since it is isomorphic to the white 3-category presented by \mathcal{A} , there exists a 4-cell $\alpha : A \Rrightarrow B \in \mathcal{A}_4^{\mathbf{w}(3)}$, which proves that \mathcal{A} is S -coherent. \square

3.2.3 Injective functors between white categories

Definition 3.2.3.1. Let Σ and Γ be two (n, k) -polygraphs (resp. white (n, k) -polygraphs), and let $F : \Sigma \rightarrow \Gamma$ be a morphism of (n, k) -polygraphs (resp. white (n, k) -polygraphs). We say that F is *injective* if for all $j \leq n$ it induces an injective application from Σ_n to Γ_n .

Definition 3.2.3.2. Let \mathcal{C} and \mathcal{D} be two white n -categories, and let $F : \mathcal{C} \rightarrow \mathcal{D}$ be a morphism of white n -categories. We say that F is *injective* if for all $j \leq n$ it induces an injective application from \mathcal{C} to \mathcal{D} .

Remark 3.2.3.3. An injective morphism between (n, k) -polygraphs does not always induce an injective functor between the free (n, k) -categories they generate. To show that, we are going to define two 2-polygraphs Σ and Γ , an injective morphism of 2-polygraphs $F : \Sigma \rightarrow \Gamma$, and two distinct 2-cells $f, g \in \Sigma^{*(1)}$ such that $F^{*(1)}(f) = F^{*(1)}(g)$.

Let Σ be the following 2-polygraph:

$$\Sigma_0 = \{*\} \quad \Sigma_1 = \{ | : * \rightarrow * \} \quad \Sigma_2 := \{ \circlearrowleft, \circlearrowright : | \Rightarrow | \}$$

and Γ :

$$\Gamma_0 = \{*\} \quad \Gamma_1 = \{ | : * \rightarrow * \} \quad \Gamma_2 := \{ \circlearrowleft, \circlearrowright : | \Rightarrow |, \bullet : | \rightarrow 1_* \}$$

Let F be the inclusion of Σ into Γ , $f = \circlearrowleft$ and $g = \circlearrowright$. They are distinct elements of $\Sigma_2^{*(1)}$. However, using the exchange law, the following equality holds in $\Gamma_2^{*(1)}$, where \blacklozenge denotes the inverse of \bullet :

$$F(f) = \begin{array}{c} \bullet \\ \circ \\ \square \\ \bullet \\ \bullet \\ \bullet \\ \bullet \end{array} = \begin{array}{c} \bullet \\ \circ \\ \bullet \\ \bullet \\ \bullet \\ \bullet \\ \bullet \end{array} = \begin{array}{c} \bullet \\ \bullet \\ \bullet \\ \bullet \\ \bullet \\ \bullet \\ \bullet \end{array} = \begin{array}{c} \bullet \\ \square \\ \bullet \\ \bullet \\ \bullet \\ \bullet \\ \bullet \end{array} = \begin{array}{c} \bullet \\ \circ \\ \bullet \\ \bullet \\ \bullet \\ \bullet \\ \bullet \end{array} = F(g)$$

In what follows, we prove some sufficient conditions so that a morphism between two white (n, k) -polygraphs induces an injective functor between the (n, k) -categories they present. This is achieved in Proposition 3.2.3.8. This result will be used in Section 3.3.3.

To prove this result, we start by studying the more general case of an injective morphism I between white (n, k) -categories equipped with a cellular extension. When its image is *closed by divisors* (see Definition 3.2.3.5), we show a simple sufficient condition so that I induces an injective white $(n+1)$ -functor. We also show that the image of the white $(n+1)$ -functor induced by I is then automatically closed by divisors. Hence, this hypothesis disappears when we go back to morphisms of white (n, k) -polygraphs. In particular, we show that every injective morphism of white n -polygraphs induces an injective white functor between white n -categories.

For the rest of this section, we fix two white n -categories equipped with cellular extensions $(\mathcal{C}, \Sigma), (\mathcal{C}', \Sigma') \in \mathbf{WCat}^+$, and a morphism $I : (\mathcal{C}, \Sigma) \rightarrow (\mathcal{C}', \Sigma') \in \mathbf{WCat}^+$. That is, I is given by a white n -functor $I : \mathcal{C} \rightarrow \mathcal{C}'$ together with an application $I_{n+1} : \Sigma \rightarrow \Sigma'$ such that the following squares commute:

$$\begin{array}{ccc} \Sigma & \xrightarrow{I_{n+1}} & \Sigma' \\ \downarrow s & = & \downarrow s \\ \mathcal{C} & \xrightarrow{I} & \mathcal{C}' \end{array} \quad \begin{array}{ccc} \Sigma & \xrightarrow{I_{n+1}} & \Sigma' \\ \downarrow t & = & \downarrow t \\ \mathcal{C} & \xrightarrow{I} & \mathcal{C}' \end{array}$$

We denote by $I^{\mathbf{w}}$ (resp. $I^{\mathbf{w}(n)}$) the white $(n+1)$ -functor $\mathcal{L}^{\mathbf{w}}(I)$ (resp. $\mathcal{L}^{\mathbf{w}(n)}(I)$). By definition, $I^{\mathbf{w}}$ (resp. $I^{\mathbf{w}(n)}$) is induced by an application from E_{Σ}^T to $E_{\Sigma'}^T$ (resp. from F_{Σ}^T to $F_{\Sigma'}^T$), that we again denote by $I^{\mathbf{w}}$ (resp. $I^{\mathbf{w}(n)}$).

Using their explicit definitions, the following properties of $I^{\mathbf{w}}$ (resp. $I^{\mathbf{w}(n)}$) hold:

- Any element of E_{Σ}^T (resp. F_{Σ}^T) whose image is an i -composite is an i -composite.
- Any element of E_{Σ}^T (resp. F_{Σ}^T) whose image is an identity is an identity.
- Any element of E_{Σ}^T (resp. F_{Σ}^T) whose image is a $c_{u'A'v'}$ is a c_{uAv} .
- Any element of F_{Σ}^T whose image by $I^{\mathbf{w}(n)}$ is a $c_{u'\bar{A}'v'}$ is a $c_{u\bar{A}v}$.

Lemma 3.2.3.4. *Assume that the application I_{n+1} is injective, and that I induces an injection on \mathcal{C} .*

Then the applications $I^{\mathbf{w}} : E_{\Sigma}^T \rightarrow E_{\Sigma'}^T$ and $I^{\mathbf{w}(n)} : F_{\Sigma}^T \rightarrow F_{\Sigma'}^T$ are injective.

Proof. Let $a_1, a_2 \in E_{\Sigma}^T$ such that $I^{\mathbf{w}}(a_1) = I^{\mathbf{w}}(a_2)$. We reason by induction on the structure of $I^{\mathbf{w}}(a_1)$.

If $I^{\mathbf{w}}(a_1) = c_{u'A'v'}$, with $u', v' \in \mathcal{C}'_1$ and $A' \in \Sigma'$. Then there are $u_1, v_1, u_2, v_2 \in \mathcal{C}_1$ and $A_1, A_2 \in \Sigma$ such that $a_1 = c_{u_1A_1v_1}$ and $a_2 = c_{u_2A_2v_2}$, and so:

$$I(u_1) = I(u_2) = u' \quad I_{n+1}(A_1) = I_{n+1}(A_2) = A' \quad I(v_1) = I(v_2) = v'.$$

Since I and I_{n+1} are injective, we get:

$$u_1 = u_2 \quad A_1 = A_2 \quad v_1 = v_2,$$

which proves that $a = b$.

If $I^{\mathbf{w}}(a_1) = i_{f'}$, with $f' \in \mathcal{C}'_n$. Then there exist $f_1, f_2 \in \mathcal{C}_n$ such that:

$$a_1 = i_{f_1} \quad a_2 = i_{f_2} \quad I(f_1) = f' \quad I(f_2) = f'.$$

Since I is injective, $f_1 = f_2$, and so $a_1 = a_2$.

If $I^{\mathbf{w}}(a_1) = A' \bullet_i B'$, with $i < n$, and $A', B' \in E_{\Sigma'}^T$. Then there exist $A_1, A_2, B_1, B_2 \in E_{\Sigma}^T$ such that:

$$a_1 = A_1 \bullet_i B_1 \quad a_2 = A_2 \bullet_i B_2 \quad I^{\mathbf{w}}(A_1) = I^{\mathbf{w}}(A_2) = A' \quad I^{\mathbf{w}}(B_1) = I^{\mathbf{w}}(B_2) = B'.$$

Using the induction hypothesis, we get that $A_1 = A_2$ and $B_1 = B_2$, and so $a_1 = a_2$.

In the case of $I^{\mathbf{w}(n)}$, we reason as previously, and we have one more case to check: if $I^{\mathbf{w}(n)}(a_1) = c_{u'\bar{A}'v'}$, with $u', v' \in \mathcal{C}'_1$ and $A' \in \Sigma'$. Then there are $u_1, v_1, u_2, v_2 \in \mathcal{C}_1$ and $A_1, A_2 \in \Sigma$ such that $a_1 = c_{u_1\bar{A}_1v_1}$ and $a_2 = c_{u_2\bar{A}_2v_2}$, and so:

$$I(u_1) = I(u_2) = u' \quad I_{n+1}(A_1) = I_{n+1}(A_2) = A' \quad I(v_1) = I(v_2) = v'.$$

Using the injectivity of I and I_{n+1} , we get:

$$u_1 = u_2 \quad A_1 = A_2 \quad v_1 = v_2,$$

and finally $a_1 = a_2$. □

Definition 3.2.3.5. Let \mathcal{C} be a white n -category, and E be a subset of \mathcal{C}_n . We say that E is *closed by divisors* if, for any $f \in E$, if $f = f_1 \bullet_i f_2$, then f_1 and f_2 are in E .

Lemma 3.2.3.6. Assume the image of I in \mathcal{C}_n is closed by divisors, and that I and I_{n+1} are injective.

Then, for every $a', b' \in E_{\Sigma'}^T$, such that $a' \equiv_{\Sigma'} b'$, and for every $a \in E_{\Sigma}^T$ such that $I^{\mathbf{w}}(a) = a'$, there exists $b \in E_{\Sigma}^T$ such that

$$I^{\mathbf{w}}(b) = b' \quad a \equiv_{\Sigma} b.$$

Assume moreover that the application I_{n+1} is bijective and that I is bijective on the 1-cells of \mathcal{C} .

Then, for every $a', b' \in F_{\Sigma'}^T$, such that $a' \cong_{\Sigma'} b'$, and for every $a \in F_{\Sigma}^T$ such that $I^{\mathbf{w}(n)}(a) = a'$, there exists $b \in F_{\Sigma}^T$ such that

$$I^{\mathbf{w}(n)}(b) = b' \quad a \cong_{\Sigma} b$$

.

Proof. To show the result on $I^{\mathbf{w}}$ we reason by induction on the structure of a' .

If there exist $A', B', C', D' \in E_{\Sigma'}^T$, $0 < i_1 < i_2 \leq n$ and $a \in E_{\Sigma}^T$ such that:

$$a' = (A' \bullet_{i_1} B') \bullet_{i_2} (C' \bullet_{i_1} D') \quad b' = (A' \bullet_{i_2} C') \bullet_{i_1} (B' \bullet_{i_2} D') \quad I^{\mathbf{w}}(a) = a',$$

then, $a = (A \bullet_{i_1} B) \bullet_{i_2} (C \bullet_{i_1} D)$, with $A, B, C, D \in E_{\Sigma}^T$. Let $b := (A \bullet_{i_2} C) \bullet_{i_1} (B \bullet_{i_2} D)$: by construction, we have $I^{\mathbf{w}}(b) = b'$ and $a \equiv_{\Sigma} b$. The case where the roles of a' and b' are reversed is symmetrical.

If there exist $A', B', C' \in E_{\Sigma'}^T$, $0 < i \leq n$ and $a \in E_{\Sigma}^T$ such that:

$$a' = (A' \bullet_i B') \bullet_i C' \quad b' = A' \bullet_i (B' \bullet_i C') \quad I^{\mathbf{w}}(a) = a',$$

then, $a = (A \bullet_i B) \bullet_i C$, with $A, B, C \in E_{\Sigma}^T$. Let $b := A \bullet_i (B \bullet_i C)$: By construction, we have $I^{\mathbf{w}}(b) = b'$ and $a \equiv_{\Sigma} b$. The case where the roles of a' and b' are reversed is symmetrical.

If there exist $A' \in E_{\Sigma}^T$, $f' \in \mathcal{C}'_n$ and $a \in E_{\Sigma}^T$ such that

$$a' = i_{f'} \bullet_n A' \quad b' = A' \quad I^{\mathbf{w}}(a) = a',$$

then $a = i_f \bullet_n A$, with $f \in \mathcal{C}_n$ and $A \in E_{\Sigma}^T$. Let $b := A'$: by construction, we have $I^{\mathbf{w}}(b) = b'$ and $a \equiv_{\Sigma} b$.

If there exist $A' \in E_{\Sigma}^T$, $f' \in \mathcal{C}'_n$ and $a \in E_{\Sigma}^T$ such that

$$a' = A' \quad b' = i_{f'} \bullet_n A' \quad I^{\mathbf{w}}(a) = a',$$

let $b := i_{s(A)} \bullet_n a$. Since b' is well typed, we have $f' = s(A')$, hence $I(s(A)) = s(I^{\mathbf{w}}(A)) = s(A') = f'$, and so $I^{\mathbf{w}}(b) = b'$ and $a \equiv_{\Sigma} b$. The case of the right-unit is symmetrical.

If there are $f'_1, f'_2 \in \mathcal{C}'_n$, $i < n$ and $a \in E_{\Sigma}^T$ such that:

$$a' = i_{f'_1} \bullet_i i_{f'_2} \quad b' = i_{f'_1 \bullet_i f'_2} \quad I^{\mathbf{w}}(a) = a',$$

then $a = i_{f_1} \bullet_i i_{f_2}$, with $f_1, f_2 \in \mathcal{C}_n$. Let $b := i_{f_1 \bullet_i f_2}$: by construction, we have $I^{\mathbf{w}}(b) = b'$ and $a \equiv_{\Sigma} b$.

If there are $f'_1, f'_2 \in \mathcal{C}'_n$, $i < n$ and $a \in E_{\Sigma}^T$ such that:

$$a' = i_{f'_1 \bullet_i f'_2} \quad b' = i_{f'_1} \bullet_i i_{f'_2} \quad I^{\mathbf{w}}(a) = a'$$

then $a = i_f$, with $f \in \mathcal{C}_n$. Since the image of I in \mathcal{C}_n is closed by divisors, there exist $f_1, f_2 \in \mathcal{C}_n$ such that

$$I(f_1) = f'_1 \quad I(f_2) = f'_2 \quad f = f_1 \bullet_i f_2.$$

Let us define $b' := i_{f_1} \bullet_i i_{f_2}$: By construction, we have $I^{\mathbf{w}}(b) = b'$ and $a \equiv_{\Sigma} b$.

If there are $A'_1, A'_2, B' \in E_{\Sigma'}^T$, $i \leq n$ and $a \in E_{\Sigma}^T$ such that:

$$a' = A'_1 \bullet_i B' \quad A'_1 \equiv_{\Sigma'} A'_2 \quad b' = A'_2 \bullet_i B' \quad I^{\mathbf{w}}(a) = a'$$

then $a = A_1 \bullet_i B$, with $A_1, B \in E_{\Sigma}^T$. Using the induction hypothesis, there exist $A_2 \in E_{\Sigma}^T$ such that $I^{\mathbf{w}}(A_2) = A'_2$ and $A_1 \equiv_{\Sigma} A_2$. Let us define $b := A_2 \bullet_i B$: by construction, we have $I^{\mathbf{w}}(b) = b'$ and $a \equiv_{\Sigma} b$. The last case is symmetric.

In the case of $I^{\mathbf{w}(n)}$, we reason as previously, and we have two more cases to check. If there exist $u', v' \in \mathcal{C}'_1$, $A \in \Sigma'$ and $a \in F_{\Sigma}^T$ such that:

$$a' = c_{u'A'v'} \bullet_n c_{u'\bar{A}'v'} \quad b' = i_{u' s(A')v'} \quad I^{\mathbf{w}(n)}(a) = a'$$

then $a = c_{u_1 A_1 v_2} \bullet_n c_{u_2 \bar{A}_2 v_2}$, with $u_1, u_2, v_1, v_2 \in \mathcal{C}_1$ and $A_1, A_2 \in \Sigma$ such that:

$$I(u_1) = I(u_2) = u' \quad I(v_1) = I(v_2) = v' \quad I_{n+1}(A_1) = I_{n+1}(A_2) = A.$$

Let $b := i_{u_1 s(A_1) v_1}$. Since I and I_{n+1} are injective, we have $I^{\mathbf{w}}(b) = b'$ and $a \cong_{\Sigma} b$.

If there exist $u', v' \in \mathcal{C}'_1$, $A \in \Sigma'$ and $a \in F_{\Sigma}^T$ such that

$$a' = i_{u' s(A') v'} \quad b' = c_{u'A'v'} \bullet_n c_{u'\bar{A}'v'} \quad I^{\mathbf{w}(n)}(a) = a'$$

Then $a = i_f$, with $f \in \mathcal{C}_n$. Let $b' := c_{uAv} \bullet_i c_{u\bar{A}v}$, with $u = I^{-1}(u')$, $v = I^{-1}(v')$ and $A = I_{n+1}^{-1}(A')$: by construction, we have $I^{\mathbf{w}}(b) = b'$ and $a \cong_{\Sigma} b$. The final case is symmetrical. \square

Lemma 3.2.3.7. *Assume that I_{n+1} and I are injective, and that the image of I in \mathcal{C}_n is closed by divisors. Then the functor $I^{\mathbf{w}} : L^{\mathbf{w}}(\mathcal{C}, \Sigma) \rightarrow L^{\mathbf{w}}(\mathcal{C}', \Sigma')$ is injective, and its image is closed by divisors.*

Assume moreover that I_{n+1} is bijective, and that I is bijective on the 1-cells of \mathcal{C} . Then the functor $I^{\mathbf{w}(n)} : L^{\mathbf{w}(n)}(\mathcal{C}, \Sigma) \rightarrow L^{\mathbf{w}(n)}(\mathcal{C}', \Sigma')$ is injective and its image is closed by divisors.

Proof. Let $f_1, f_2 \in L^{\mathbf{w}}(\mathcal{C}, \Sigma)$ and $a_1, a_2 \in E_{\Sigma}^T$ such that:

$$I^{\mathbf{w}}(f_1) = I^{\mathbf{w}}(f_2) \quad [a_1] = f_1 \quad [a_2] = f_2.$$

Then $[I^{\mathbf{w}}(a_1)] = [I^{\mathbf{w}}(a_2)]$, that is $I^{\mathbf{w}}(a_1) \equiv_{\Sigma'}^* I^{\mathbf{w}}(a_2)$. Hence, by definition, there exist $n > 0$ and $t'_1, \dots, t'_n \in E_{\Sigma'}^T$ such that:

$$t'_1 = I^{\mathbf{w}}(a_1) \quad t'_i \equiv_{\Sigma'} t'_{i+1} \quad t'_n = I^{\mathbf{w}}(a_2).$$

Applying Lemma 3.2.3.6 successively, we get $t_1, \dots, t_n \in E_{\Sigma'}^T$ such that:

$$t_1 = a_1 \quad t_i \equiv_{\Sigma} t_{i+1} \quad I^{\mathbf{w}}(t_i) = t'_i.$$

In particular $a_1 \equiv_{\Sigma}^* t_n$ and $I^{\mathbf{w}}(t_n) = t'_n = I^{\mathbf{w}}(a_2)$. Using Lemma 3.2.3.4, this implies that $t_n = a_2$, and so $a_1 \equiv_{\Sigma}^* a_2$, which proves that $f_1 = [a_1] = [a_2] = f_2$.

It remains to show that the image of $I^{\mathbf{w}}$ is closed by divisors. Let $f', f'_1, f'_2 \in L^{\mathbf{w}}(\mathcal{C}', \Sigma')$ and $i \leq n$ such that $f' = f'_1 \bullet_i f'_2$, and assume that there is an $f \in L^{\mathbf{w}}(\mathcal{C}', \Sigma')$ such that $I^{\mathbf{w}}(f) = f'$. Let $a \in E_{\Sigma}^T$ and $b'_1, b'_2 \in E_{\Sigma'}^T$ such that:

$$[a] = f \quad [b'_1] = f'_1 \quad [b'_2] = f'_2.$$

In particular, we have $I^{\mathbf{w}}(a) \equiv_{\Sigma'}^* b'_1 \bullet_i b'_2$. Using both Lemmas 3.2.3.4 and 3.2.3.6 as before, we get an element $b \in E_{\Sigma}^T$ such that:

$$a \equiv_{\Sigma}^* b \quad I^{\mathbf{w}}(b) = b'_1 \bullet_i b'_2.$$

Since the image of $I^{\mathbf{w}}$ is closed by divisors, there exists $b_1, b_2 \in E_{\Sigma}^T$ such that $b = b_1 \bullet_i b_2$. Let $f_1 := [b_1]$ and $f_2 := [b_2]$: by construction we have:

$$I^{\mathbf{w}}(f_1) = f'_1 \quad I^{\mathbf{w}}(f_2) = f'_2 \quad f_1 \bullet_i f_2 = f.$$

The case of $I^{\mathbf{w}(n)}$ is identical, the only difference lying in the hypothesis needed to apply Lemma 3.2.3.6. \square

Proposition 3.2.3.8. *Let Σ and Γ be two white (n, k) -polygraphs and $I : \Sigma \rightarrow \Gamma$ be an injective morphism of (n, k) -polygraphs. Then for every $j \leq k$ the functor $I_j^{\mathbf{w}} : \Sigma_j^{\mathbf{w}} \rightarrow \Gamma_j^{\mathbf{w}}$ is injective, and its image is closed by divisors.*

Assume moreover that I_0 and I_1 are bijections, and that for every $j > k$ the application $I_j : \Sigma_j \rightarrow \Gamma_j$ is bijective. Then for every j the functor $I_j^{\mathbf{w}(k)} : \Sigma_j^{\mathbf{w}(k)} \rightarrow \Gamma_j^{\mathbf{w}(k)}$ is injective, and its image is closed by divisors.

Proof. We reason by induction on j . The case $j = 0$ is true by hypothesis.

Let $1 \leq j \leq k$. By hypothesis, the application I_j is injective, and by induction hypothesis, the functor $I_{j-1}^{\mathbf{w}}$ is injective with image closed by divisors. Hence, I_j satisfies the hypothesis of Lemma 3.2.3.7, and $I_j^{\mathbf{w}}$ is injective with image closed by divisors.

Let $j > k$. Again, using the hypothesis and induction hypothesis, we get that I_j satisfies the hypotheses of Lemma 3.2.3.7. Hence, $I_j^{\mathbf{w}(k)}$ is injective and its image is closed by divisors. \square

In what follows, we use the fact that the image of a functor generated by a morphism of polygraphs is closed by divisors in order to prove a characterisation of the image of such a functor.

Definition 3.2.3.9. Let \mathcal{C}, \mathcal{D} be two white n -categories, $F : \mathcal{C} \rightarrow \mathcal{D}$ be an n -functor and f be an n -cell of \mathcal{D} . We say that F *k-discriminates* f if the following are equivalent:

1. The k -source of f is in the image of F .
2. The k -target of f is in the image of F .
3. The n -cell f is in the image of F .

Given a subset D of \mathcal{D}_n , we say that F is *k-discriminating on D* if for every n -cell f in D , F *k-discriminates* f .

Lemma 3.2.3.10. Assume that the image of I is closed by divisors, that the application I_n is injective, and that I is *n-discriminating on Σ'* .

Then, $I^{\mathbf{w}}$ (resp. $I^{\mathbf{w}(n)}$) is *n-discriminating on $L^{\mathbf{w}}(\mathcal{C}', \Sigma')$* (resp. $L^{\mathbf{w}(n)}(\mathcal{C}', \Sigma')$).

Proof. Let us start with $I^{\mathbf{w}}$. Let E be the set all $(n+1)$ -cells of $L^{\mathbf{w}}(\mathcal{C}', \Sigma')$ which $I^{\mathbf{w}}$ discriminates. Let us show that $E = L^{\mathbf{w}}(\mathcal{C}', \Sigma')$. Since $I^{\mathbf{w}}$ commutes with the source and target applications, the implications (3) \Rightarrow (1) and (3) \Rightarrow (2) hold for any cell in $L^{\mathbf{w}}(\mathcal{C}', \Sigma')$. So in order to show that a cell is in E , it remains to show that it verifies the implications (1) \Rightarrow (3) and (2) \Rightarrow (3).

The set E contains all units. Indeed, let $A' = 1_{f'}$, with $f' \in \mathcal{C}'$. If $s(A') = f'$ is in the image of $I^{\mathbf{w}}$, there exists $f \in \mathcal{C}$ such that $I(f) = f'$. Let us define $A = 1_f \in L^{\mathbf{w}}(\mathcal{C}, \Sigma)$: by construction we have $I^{\mathbf{w}}(A) = 1_{I(f)} = 1_{f'} = A'$, hence the implication (1) \Rightarrow (3) holds for A' . Moreover, since $t(A') = s(A')$, the implication (2) \Rightarrow (3) also holds for A .

The set E contains all cells of length 1. Indeed, given such a cell A' , there exist $f'_k, g'_k \in \mathcal{C}'_k$ and $A'_0 \in \Sigma'$ such that

$$A' = f'_n \bullet_{n-1} (f'_{n-1} \bullet_{n-2} \dots \bullet_2 (f'_1 A'_0 g'_1) \bullet_2 \dots \bullet_{n-2} g'_{n-1}) \bullet_{n-1} g'_n.$$

Let $A'_k := f'_k \bullet_{k-1} (f'_{k-1} \bullet_{k-2} \dots \bullet_2 (f'_1 A'_0 g'_1) \bullet_2 \dots \bullet_{k-2} g'_{k-1}) \bullet_{k-1} g'_k$. Suppose that the source (resp. target) of A' is in the image of I , and let us show that A' is in the image of $I^{\mathbf{w}}$. Since the image of I is closed by divisors, we get first that f'_n, g'_n and $s(A'_{n-1})$ (resp. $t(A'_{n-1})$) are in the image of I . By iterating this reasoning, we get that, for all i , f'_i, g'_i and $s(A'_{i-1})$ (resp. $t(A'_{i-1})$) are in the image of I . Since $I^{\mathbf{w}}$ discriminates Σ' , there exist $f_k, g_k \in \mathcal{C}_k$ and $A_0 \in \Sigma$ such that:

$$I(f_k) = f'_k \quad I(g_k) = g'_k \quad I_{n+1}(A_0) = A'_0.$$

By induction on k we show that $A_k := f_k \bullet_{k-1} A_{k-1} \bullet_{k-1} g_k$ is well-defined and that $I^{\mathbf{w}}(A_k) = A'_k$. Indeed, assume that it is true at rank $k-1$. Then we have the equalities:

$$I(t(f_k)) = t(f'_k) = s_{k-1}(A'_{k-1}) = I(s_{k-1}(A_{k-1})) \quad I(t_{k-1}(A_{k-1})) = t_{k-1}(A'_{k-1}) = s(g'_k) = I(s(g_k))$$

Using the injectivity of I we get that $t(f_k) = s_{k-1}(A_{k-1})$ and $t_{k-1}(A_{k-1}) = s(g_k)$, which shows that A_k is well-defined, and finally:

$$I^{\mathbf{w}}(A_k) = f'_k \bullet_{k-1} A'_{k-1} \bullet_{k-1} g'_k = A'_k.$$

In particular, we have $A'_n = I^{\mathbf{w}}(A_n)$.

The set E is stable by n -composition. Indeed, let $A', B' \in E$, and assume that the source of $A' \bullet_n B'$ is in the image of I . Let us show that $A' \bullet_n B'$ is in the image of $I^{\mathbf{w}}$. The source of $A' \bullet_n B'$ is none other than the one of A' . Since A' is in E , there exists $A \in \mathcal{L}^{\mathbf{w}}(\mathcal{C}, \Sigma)$ such that $I^{\mathbf{w}}(A) = A'$. Hence, the source of B' is in the image of I , and since $B' \in E$, there exists $B \in \mathcal{L}^{\mathbf{w}}(\mathcal{C}, \Sigma)$ such that $I^{\mathbf{w}}(B) = B'$. Moreover, we have $I(t(A)) = t(A') = s(B') = I(s(B))$, so using the injectivity of I we get $t(A) = s(B)$. Hence, the cell $A \bullet_n B$ is well-defined and satisfies:

$$I^{\mathbf{w}}(A \bullet_n B) = I^{\mathbf{w}}(A) \bullet_n I^{\mathbf{w}}(B) = A' \bullet_n B'.$$

The case where the target of $A' \bullet_n B'$ is in the image of I is symmetrical.

This concludes the proof for $I^{\mathbf{w}}$. Concerning $I^{\mathbf{w}^{(n)}}$, the reasoning is the same except that we also have to show that E is stable under inversion. Indeed, let $A' \in E$ and assume that the source (resp. target) of $(A')^{-1}$ is in the image of I . Then the target (resp. source) of A' is in the image of I and since A' is in E , there exists $A \in \mathcal{L}^{\mathbf{w}^{(n)}}(\mathcal{C}, \Sigma)$ such that $I^{\mathbf{w}^{(n)}}(A) = A'$, and so $I^{\mathbf{w}^{(n)}}(A^{-1}) = (A')^{-1}$. \square

Proposition 3.2.3.11. *Let Σ and Γ be two white (n, k) -polygraphs, and $I : \Sigma \rightarrow \Gamma$ be a morphism of polygraphs. Let k_0 such that for every $j > k_0$, I_j is a bijection.*

Assume that I satisfies the hypothesis of Proposition 3.2.3.8, and that, for every $j > k_0$, I_j is k_0 -discriminating on Γ_j . Then for every $j \geq k_0$, $I_j^{\mathbf{w}^{(k)}}$ is k_0 -discriminating on $\Gamma_j^{\mathbf{w}^{(k)}}$.

Proof. Since I satisfies the hypotheses of Proposition 3.2.3.8, we know that for every j , the functor $I_j^{\mathbf{w}^{(k)}}$ is injective, and that its image is closed by divisors.

We reason by induction on $j > k_0$. For $j = k_0 + 1$, the result is a direct application of Lemma 3.2.3.10.

Let $j > k_0 + 1$: let us show that $I_j^{\mathbf{w}^{(k)}}$ is $(j - 1)$ -discriminating on Γ_j . Let $A \in \Gamma_j$. If $s(A)$ (resp. $t(A)$) is in the image of $I_{j-1}^{\mathbf{w}^{(k)}}$ then in particular, the k_0 -source (resp. k_0 -target) of A is in the image of $I_{k_0}^{\mathbf{w}^{(k)}}$. Since $I_j^{\mathbf{w}^{(k)}}$ is k_0 -discriminating on Γ_j , A is in the image of $I_j^{\mathbf{w}^{(k)}}$. Hence, we can use Lemma 3.2.3.10, and we get that $I_j^{\mathbf{w}^{(k)}}$ is $(j - 1)$ -discriminating on $\Gamma_j^{\mathbf{w}^{(k)}}$. Let $A \in \Gamma_j^{\mathbf{w}^{(k)}}$. If its k_0 -source (resp. k_0 -target) is in the image of $I_{k_0}^{\mathbf{w}^{(k)}}$ then, by induction hypothesis, the source (rep. target) of A is in the image of $I_{j-1}^{\mathbf{w}^{(k)}}$, and so A is in the image of $I_j^{\mathbf{w}^{(k)}}$, which proves that $I_j^{\mathbf{w}^{(k)}}$ is k_0 -discriminating. \square

Name	Description	Commentary
$(\mathcal{A}^{*(2)}, S_{\mathcal{A}})$	\mathcal{A}_2 \mathcal{A}_3 \mathcal{A}_4	
$(\mathcal{B}^{\mathbf{w}(2)}, S_{\mathcal{B}})$	\mathcal{A}_2 $\mathcal{A}_3 \cup K$ $\mathcal{A}_4 \cup L$	Weakening of the exchange law ¹
$(\mathcal{C}^{\mathbf{w}(3)}, S_{\mathcal{C}})$	\mathcal{A}_2 $\mathcal{A}_3 \cup \mathcal{A}_3^{op} \cup K \cup K^{op}$ $\mathcal{A}_4 \cup L \cup \{\rho_A, \lambda_A\}$	Weakening of the invertibility of 3-cells
$(\mathcal{D}^{\mathbf{w}(3)}, S_{\mathcal{D}})$	$\mathcal{A}_2 \cup \mathcal{A}_2^{op}$ $\mathcal{A}_3 \cup \mathcal{A}_3^{op} \cup K \cup K^{op}$ $\mathcal{A}_4 \cup L \cup \{\rho_A, \lambda_A\}$	Adjunction of formal inverses to 2-cells
$(\mathcal{E}^{\mathbf{w}(3)}, S_{\mathcal{E}})$	$\mathcal{A}_2 \cup \mathcal{A}_2^{op}$ $\mathcal{A}_3 \cup \mathcal{A}_3^{op} \cup K \cup K^{op} \cup \{\eta_f, \epsilon_f\}$ $\mathcal{A}_4 \cup L \cup \{\rho_A, \lambda_A\} \cup \{\tau_f, \sigma_f\}$	Adjunction of connections between 2-cells

Table 3.3: List of the successive transformations of \mathcal{A} .

3.3 Transformation of a $(4, 2)$ -polygraph into a white $(4, 3)$ -polygraph

The proof of Theorem 3.1.3.5 will occupy the rest of this article. We start with a $(4, 2)$ -polygraph \mathcal{A} satisfying the hypotheses of Theorem 3.1.3.5. Let $S_{\mathcal{A}}$ be the set of all 2-cells in \mathcal{A}_2^* whose target is a normal form. Then proving Theorem 3.1.3.5 consists in showing that \mathcal{A} is $S_{\mathcal{A}}$ -coherent.

In this section we successively transform \mathcal{A} four times, leading to five pointed white $(4, 3)$ -categories, namely $(\mathcal{A}^{*(2)}, S_{\mathcal{A}})$, $(\mathcal{B}^{\mathbf{w}(2)}, S_{\mathcal{B}})$, $(\mathcal{C}^{\mathbf{w}(3)}, S_{\mathcal{C}})$, $(\mathcal{D}^{\mathbf{w}(3)}, S_{\mathcal{D}})$ and $(\mathcal{E}^{\mathbf{w}(3)}, S_{\mathcal{E}})$, and we show each time that the new pointed white $(4, 3)$ -category is stronger than the previous one. A brief description of each pointed white $(4, 3)$ -category can be seen in Table 3.3. Finally, in Section 3.3.5, we perform a number of Tietze-transformations on the white 4-polygraph \mathcal{E} , leading to a white 4-polygraph \mathcal{F} .

Thanks to Lemma 3.2.2.8 and Proposition 3.2.2.14, we know that in order to show that $\mathcal{A}^{*(2)}$ is $S_{\mathcal{A}}$ -coherent, it is enough to show that $\mathcal{F}^{\mathbf{w}(3)}$ is $S_{\mathcal{E}}$ -coherent. This will be done in Section 3.4.

Example 3.3.0.1. We have already shown in Section 2.3 that for every sets \mathbf{C}, \mathbf{D} and for every applications $\mathbf{f}, \mathbf{g} : \mathbf{C} \rightarrow \mathbf{D}$, the $(4, 2)$ -polygraph $\mathbf{PNTrans}^{++}[\mathbf{f}, \mathbf{g}]$ satisfies the hypothesis of Theorem 3.1.3.5.

In what follows, we will use as a running example the polygraph $\mathcal{A} = \mathbf{Assoc}$ which consists of one 0-cell, one 1-cell $|$, one 2-cell $\nabla : | \Rightarrow |$, one 3-cell $\nabla : \nabla \Rightarrow \nabla$, and one 4-cell ∇ :

¹The sets K and L will be defined in Section 3.3.1

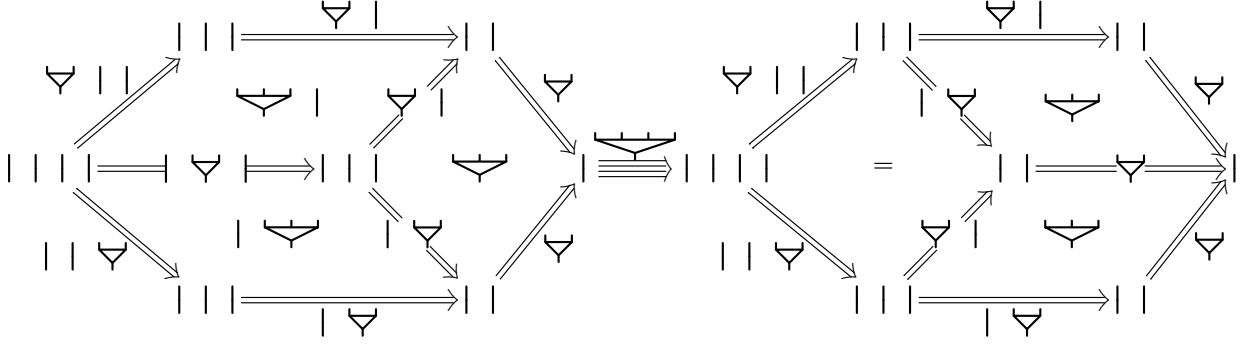

In particular, **Assoc** satisfies the 2-Squier condition of depth 2. The 2-category \mathbf{Assoc}_2^* is 2-convergent and its only normal form is the 1-cell $|$.

The corresponding set $S_{\mathcal{A}}$ is then the set of 2-cells in \mathbf{Assoc}_2^* from any 1-cell $|\dots|$ to $|$.

3.3.1 Weakening of the exchange law

We construct dimension by dimension a white $(4, 2)$ -polygraph \mathcal{B} , together with a white functor $F : \mathcal{B}^{\mathbf{w}(2)} \rightarrow \mathcal{A}^{*(2)}$. We then define a subset $S_{\mathcal{B}}$ of $\mathcal{B}^{\mathbf{w}(2)}$ and show (Proposition 3.3.1.4) using F that $(\mathcal{B}^{\mathbf{w}(2)}, S_{\mathcal{B}})$ is stronger than $(\mathcal{A}^{*(2)}, S_{\mathcal{A}})$.

In low dimensions, we set $\mathcal{B}_i = \mathcal{A}_i$, for every $i \leq 2$, and the functor F is the identity on generators.

Lemma 3.3.1.1. *The functor $F : \mathcal{B}^{\mathbf{w}} \rightarrow \mathcal{A}^*$ is 2-surjective.*

Proof. By construction, \mathcal{A}_2^* is the quotient of $\mathcal{B}_2^{\mathbf{w}}$ by the equivalence relation generated by:

$$(f \bullet_0 v) \bullet_i (u' \bullet_0 g) = (u \bullet_0 g) \bullet_i (f \bullet_0 v').$$

And F is the canonical projection induced by the quotient. □

In what follows, we suppose chosen a section $i : \mathcal{A}^* \rightarrow \mathcal{B}^{\mathbf{w}}$ of F , which is possible thanks to Lemma 3.3.1.1.

We extend \mathcal{B} into a white 3-polygraph and $F : \mathcal{B}^{\mathbf{w}} \rightarrow \mathcal{A}^*$ into a white 3-functor by setting $\mathcal{B}_3 := \mathcal{A}_3 \cup K$:

- For every 3-cell $A \in \mathcal{A}_3$, the source and target of A in $\mathcal{B}_2^{\mathbf{w}}$ are respectively $s^{\mathcal{B}}(A) := i(s^{\mathcal{A}}(A))$ and $t^{\mathcal{B}}(A) := i(t^{\mathcal{A}}(A))$.
- The set K is the set of 3-cells $A_{fv,ug}$, of shape:

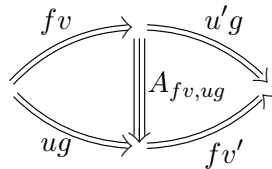

for every strict Peiffer branching (fv, ug) , where $f : u \Rightarrow u'$ and $g : v \Rightarrow v'$ are rewriting steps.

The image of a cell of \mathcal{B}_3 under F is defined as follows:

- For every strict Peiffer branching (fv, ug) , $F(A_{fv,ug}) := 1_{f \bullet_0 g}$
- For every 3-cell A in \mathcal{A}_3 , $F(A) := A$.

Lemma 3.3.1.2. *Let $f, g \in \mathcal{B}_2^{\mathbf{w}}$. There exists a 3-cell $A : f \Rrightarrow g$ in $K_3^{\mathbf{w}(2)}$ if and only if the equality $F(f) = F(g)$ holds in \mathcal{A}_2^* .*

Proof. Let $f, g \in \mathcal{B}_2^{\mathbf{w}}$. The image of any cell in $K_3^{\mathbf{w}(2)}$ by F is an identity. So if there exists a 3-cell $A : f \Rrightarrow g$ in $K_3^{\mathbf{w}(2)}$, necessarily $F(f) = F(g)$.

Conversely, the set \mathcal{A}_2^* is the quotient of $\mathcal{B}_2^{\mathbf{w}}$ by the equivalence relation generated by:

$$f s(g) \bullet_1 t(f)g = s(f)g \bullet_1 f t(g),$$

for $f, g \in \mathcal{B}_2^{\mathbf{w}}$. The 3-cells $A_{fu,vg}$, where (fu, vg) is a strict Peiffer branching, generate this relation, and they are in K . Hence, the result holds. \square

Lemma 3.3.1.3. *The functor $F : \mathcal{B}^{\mathbf{w}(2)} \rightarrow \mathcal{A}^{\mathbf{w}(2)}$ is 3-surjective.*

Proof. Let E be the set of 3-cells $A \in \mathcal{A}_3^{*(2)}$ such that, for every $f, g \in \mathcal{B}_2^{\mathbf{w}}$ in the preimage of $s(A)$ and $t(A)$ under F , there exists a 3-cell $B : f \Rrightarrow g \in \mathcal{B}_3^{\mathbf{w}(2)}$ satisfying $F(B) = A$. Let us show that $E = \mathcal{A}_3^*$. We already know that E contains the identities thanks to Lemma 3.3.1.2.

The 3-cells of length 1 in \mathcal{A}_3^* are in E . Indeed, let $A \in \mathcal{A}_3^*$ be a 3-cell of length 1, and $f, g \in \mathcal{B}_2^{\mathbf{w}}$ such that $F(f) = s(A)$ et $F(g) = t(A)$. There exist $u, v \in \mathcal{A}_1^*$, $f', g' \in \mathcal{A}_2^*$, and $A' \in \mathcal{A}_3$ such that

$$A = f' \bullet_1 (uA'v) \bullet_1 g'.$$

Let $\tilde{u}, \tilde{v}, \tilde{f}, \tilde{g}$ be in the preimages respectively of u, v, f', g' under F (they exist thanks to Lemma 3.3.1.1), and let $B_1 := \tilde{f} \bullet_1 (\tilde{u}A'\tilde{v}) \bullet_1 \tilde{g} \in \mathcal{B}_3^{\mathbf{w}(2)}$. By construction, $F(B_1) = A$, which leads to the equalities:

$$F(s(B_1)) = F(f) \quad F(t(B_1)) = F(g).$$

Thus, according to Lemma 3.3.1.2, there exist 3-cells $C_1 : f \Rrightarrow s(B_1) \in K_3^{\mathbf{w}(2)}$ and $C_2 : t(B_1) \Rrightarrow g \in K_3^{\mathbf{w}(2)}$. Let $B := C_1 \bullet_2 B_1 \bullet_2 C_2$: by construction, B has the required source and target, and moreover:

$$F(B) = F(C_1) \bullet_2 F(B_1) \bullet_2 F(C_2) = 1_{F(f)} \bullet_2 A \bullet_2 1_{F(g)} = A.$$

The set E is stable under composition. Indeed, let $A_1, A_2 \in E$ such that $t(A_1) = s(A_2)$, and $f, g \in \mathcal{B}_2^{\mathbf{w}}$ satisfying $F(f) = s(A_1)$ and $F(g) = t(A_2)$. Since F is 2-surjective, there exists $h \in \mathcal{B}_2^{\mathbf{w}}$ in the inverse image of $t(A_1)$ under F . Since A_1 (resp. A_2) is in E , there exists a cell B_1 (resp. B_2) in $\mathcal{B}_3^{\mathbf{w}(2)}$ such that $F(B_1) = A_1$ (resp. $F(B_2) = A_2$), $s(B_1) = f$ (resp. $s(B_2) = h$) and $t(B_1) = h$ (resp. $t(B_2) = g$). Let $B := B_1 \bullet_2 B_2$: we get:

$$s(B) = f \quad F(B) = A_1 \bullet_2 A_2 \quad t(B) = g$$

The set E is stable under 2-composition. Indeed, let $A \in E$ and $f, g \in \mathcal{B}_2^{\mathbf{w}}$ such that $F(f) = s(A^{-1})$ and $F(g) = t(A^{-1})$. There exists $B \in \mathcal{B}^{\mathbf{w}(2)}$ such that:

$$s(B) = g \quad F(B) = A \quad t(B) = f.$$

Hence, the cell B^{-1} satisfies the required property. \square

We now extend \mathcal{B} into a white $(4, 2)$ -polygraph and $F : \mathcal{B}^{\mathbf{w}(2)} \rightarrow \mathcal{A}^{*(2)}$ into a white 4-functor by setting $\mathcal{B}_4 = \mathcal{A}_4 \cup L$:

- For every 3-cell $A \in \mathcal{A}_4$, the source and target of A in $\mathcal{B}_3^{\mathbf{w}(2)}$ are respectively $s^{\mathcal{B}}(A) := i(s^{\mathcal{A}}(A))$ and $t^{\mathcal{B}}(A) := i(t^{\mathcal{A}}(A))$, where i is a chosen section of the application $F_3 : \mathcal{B}_3^{\mathbf{w}(2)} \rightarrow \mathcal{A}_3^{\mathbf{w}(2)}$ (which exists since F is 3-surjective). And we set $F(A) := A$.
- For every 3-fold strict Peiffer branching (f, g, h) , the set L contains a 4-cell $A_{f,g,h}$, whose shape depends on the form of the branching (f, g, h) . If $(f, g, h) = (f'v, g'v, uh')$, with (f', g') a critical pair, and $h' : v \Rightarrow v'$ then $A_{f,g,h}$ is of the following shape:

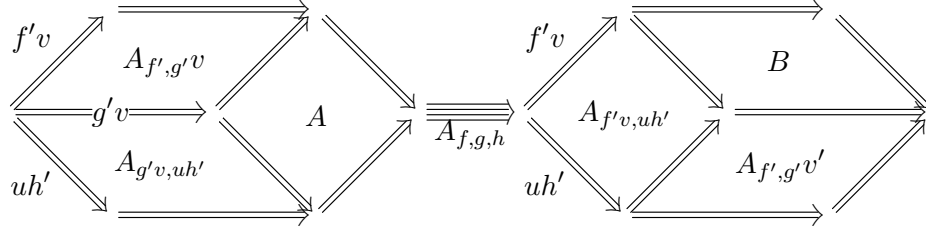

where A and B are in $K_3^{\mathbf{w}(2)}$. And we define $F(A_{f,g,h}) := 1_{A_{f',g'} \bullet_0 h'}$.

If $(f, g, h) = (f'v, ug', uh')$, with (g, h) a critical pair, and $f' : u \Rightarrow u'$ then $A_{f,g,h}$ is of the following shape:

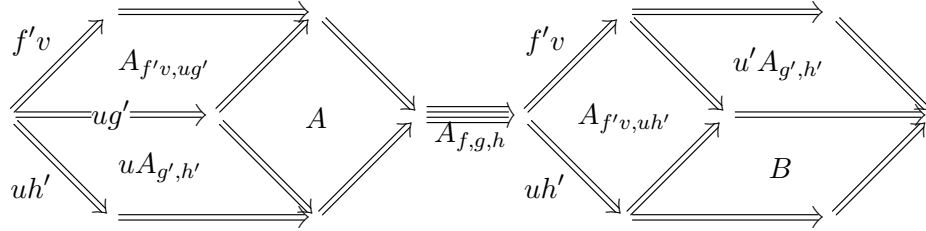

where A and B are in $K_3^{\mathbf{w}(2)}$. And we define $F(A_{f,g,h}) := 1_{f' \bullet_0 A_{g',h'}}$.

If $(f, g, h) = (f'vw, ug'w, uh'w)$, then $A_{f,g,h}$ is of the following shape, where A and B are in $K_3^{\mathbf{w}(2)}$:

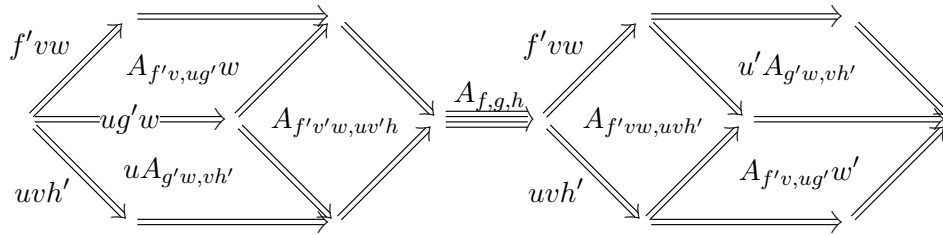

And we define $F(A_{f,g,h}) := 1_{f' \bullet_0 g' \bullet_0 h'}$.

Let now $S_{\mathcal{B}}$ be the set of all 2-cells in $\mathcal{B}^{\mathbf{w}}$ whose 1-target is a normal form.

Proposition 3.3.1.4. *The pointed white (4, 3)-category $(\mathcal{B}^{\mathbf{w}(2)}, S_{\mathcal{B}})$ is stronger than $(\mathcal{A}^{*(2)}, S_{\mathcal{A}})$.*

Proof. The functor F sends normal forms on normal forms. Hence, by restriction it induces a 2-functor $F \upharpoonright S_{\mathcal{B}} : \mathcal{B}^{\mathbf{w}(2)} \upharpoonright S_{\mathcal{B}} \rightarrow \mathcal{A}^{*(2)} \upharpoonright S_{\mathcal{A}}$.

Lemmas 3.3.1.1 and 3.3.1.3 show that it is k -surjective for every $k < 2$. Hence, we can conclude using Lemma 3.2.2.8. \square

Example 3.3.1.5. In the case where $\mathcal{A} = \mathbf{Assoc}$, the set K contains in particular the following 3-cells, associated respectively to the strict Peiffer branchings $(\nabla \mid \mid , \mid \mid \nabla)$ and $(\nabla \mid \mid \mid , \mid \mid \mid \nabla)$:

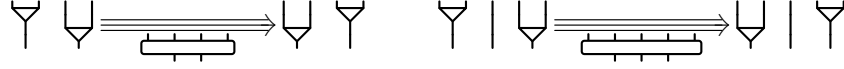

In L , the 4-cell associated to the strict Peiffer branching $(\nabla \mid \mid \mid , \mid \nabla \mid \mid , \mid \mid \mid \nabla)$ is the following:

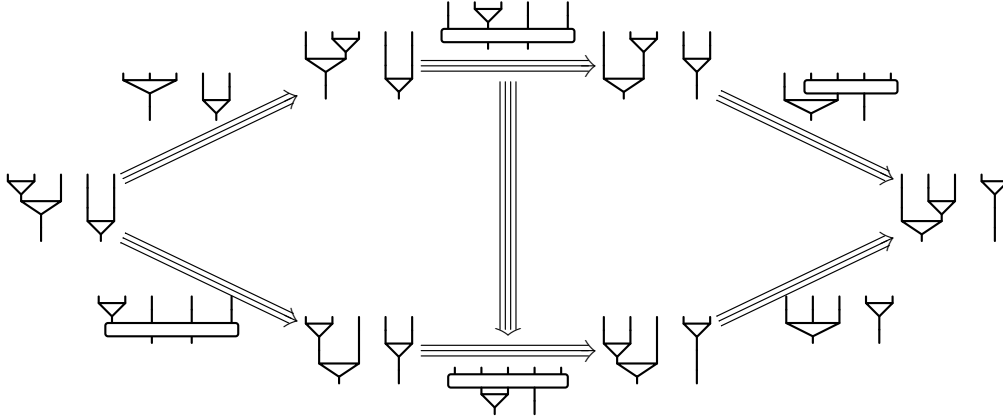

3.3.2 Weakening of the invertibility of 3-cells

We construct dimension by dimension a white 4-polygraph \mathcal{C} , together with a white 3-functor $G : \mathcal{C}^{\mathbf{w}(3)} \rightarrow \mathcal{B}^{\mathbf{w}(2)}$. We then define a subset $S_{\mathcal{C}}$ of $\mathcal{C}^{\mathbf{w}(3)}$ and show (Proposition 3.3.2.2) using G that $(\mathcal{C}^{\mathbf{w}(3)}, S_{\mathcal{C}})$ is stronger than $(\mathcal{B}^{\mathbf{w}(2)}, S_{\mathcal{B}})$.

In low dimensions, we set $\mathcal{C}_i = \mathcal{B}_i$ for $i \leq 2$, with the functor G being the identity.

We extend \mathcal{C} into a white 3-polygraph by setting $\mathcal{C}_3 := \mathcal{B}_3 \cup \mathcal{B}_3^{op}$, where the set \mathcal{B}_3^{op} contains, for every $A \in \mathcal{B}_3$, a cell denoted by A^{op} , whose source and target are given by the equalities:

$$s(A^{op}) = t(A) \quad t(A^{op}) = s(A)$$

And the functor $G : \mathcal{C}^{\mathbf{w}} \rightarrow \mathcal{B}^{\mathbf{w}(2)}$ is defined as follows for every $A \in \mathcal{B}_3$:

$$G(A) = A \quad G(A^{op}) = A^{-1}.$$

Lemma 3.3.2.1. *The functor $G : \mathcal{C}^{\mathbf{w}(3)} \rightarrow \mathcal{B}^{\mathbf{w}(2)}$ is 3-surjective.*

Proof. By definition, $\mathcal{B}_3^{\mathbf{w}(2)}$ is the quotient of $\mathcal{C}_3^{\mathbf{w}}$ by the relations $A^{op} \bullet_2 A = 1$ and $A \bullet_2 A^{op} = 1$, and G is the corresponding canonical projection. \square

We extend \mathcal{C} into a white 4-polygraph by setting $\mathcal{C}_4 := \mathcal{B}_4 \cup \{\rho_A, \lambda_A \mid A \in \mathcal{B}_3\}$, where the applications source and target $s, t : \mathcal{C}_4 \rightarrow \mathcal{C}_3^{\mathbf{w}}$ are defined as follows:

- For $A \in \mathcal{B}_4$, the cell $s^{\mathcal{C}}(A)$ (resp. $t^{\mathcal{C}}(A)$) is any cell in the preimage of $s^{\mathcal{B}}(A)$ under G , which is non-empty thanks to Lemma 3.3.2.1. And we set $G(A) := A$.

- For every $A \in \mathcal{B}_3$, the cells ρ_A and λ_A have the following shape:

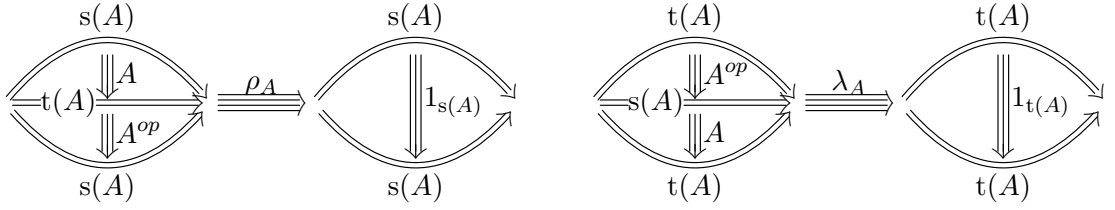

And we set $G(\rho_A) := 1_{s(A)}$ and $G(\lambda_A) := 1_{t(A)}$.

Let $S_{\mathcal{C}}$ be the set of all 2-cells in $\mathcal{C}^{\mathbf{w}}$ whose 2-target is a normal form.

Proposition 3.3.2.2. *The pointed white (4, 3)-category $(\mathcal{C}^{\mathbf{w}(3)}, S_{\mathcal{C}})$ is stronger than $(\mathcal{B}^{\mathbf{w}(2)}, S_{\mathcal{B}})$.*

Proof. The functor G restricts into a functor $G \upharpoonright S_{\mathcal{C}} : \mathcal{C}^{\mathbf{w}(3)} \upharpoonright S_{\mathcal{C}} \rightarrow \mathcal{B}^{\mathbf{w}(2)} \upharpoonright S_{\mathcal{B}}$, which is i -surjective for $i < 2$ thanks to Lemma 3.3.2.1. Hence, we can conclude thanks to Lemma 3.2.2.8. \square

Example 3.3.2.3. In the case where $\mathcal{A} = \mathbf{Assoc}$, let $A = \nabla$. The set \mathcal{C}_3 contains the following 3-cell:

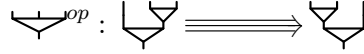

And the following cells lie in \mathcal{C}_4 , where $A = \nabla$:

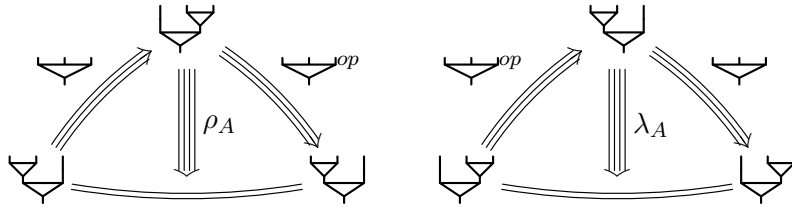

3.3.3 Adjunction of formal inverses to 2-cells

Let \mathcal{D} be the white 4-polygraph defined as follows:

$$\text{for every } i \neq 2, \mathcal{D}_i := \mathcal{C}_i \quad \mathcal{D}_2 := \mathcal{C}_2 \cup \bar{\mathcal{C}}_2,$$

where for every $f \in \mathcal{C}_2$, the set $\bar{\mathcal{C}}_2$ contains a cell \bar{f} with source $t(f)$ and with target $s(f)$. Let $S_{\mathcal{D}}$ be the set of all 2-cells of the sub- white 2-category $\mathcal{C}_2^{\mathbf{w}}$ of $\mathcal{D}_2^{\mathbf{w}}$ whose target is a normal form.

Notation 3.3.3.1. The application $\mathcal{C}_2 \rightarrow \bar{\mathcal{C}}_2$ extends into an application $\mathcal{C}_2^{\mathbf{w}} \rightarrow \bar{\mathcal{C}}_2^{\mathbf{w}}$ which exchanges the source and targets of the 2-cells.

We denote a 2-cell f by \xrightarrow{f} if f is in $\mathcal{B}_2^{\mathbf{w}}$, by \xleftarrow{f} if \bar{f} is in $\mathcal{B}_2^{\mathbf{w}}$, and by \xleftrightarrow{f} if f is any cell in $\mathcal{C}_2^{\mathbf{w}}$.

Proposition 3.3.3.2. *The pointed white (4, 3)-category $(\mathcal{D}^{\mathbf{w}(3)}, S_{\mathcal{D}})$ is stronger than $(\mathcal{C}^{\mathbf{w}(3)}, S_{\mathcal{C}})$.*

Proof. Let us show that $\mathcal{D}^{\mathbf{w}(3)} \upharpoonright S_{\mathcal{D}} = \mathcal{C}^{\mathbf{w}(3)} \upharpoonright S_{\mathcal{C}}$. Let $\iota : \mathcal{C}^{\mathbf{w}(3)} \rightarrow \mathcal{D}^{\mathbf{w}(3)}$ be the canonical inclusion functor. Since the only cells added are in dimension 2, ι satisfies the hypotheses of Proposition 3.2.3.8, thus $\mathcal{C}^{\mathbf{w}}$ is a sub- white 4-category of $\mathcal{D}^{\mathbf{w}}$, which gives us an inclusion $\mathcal{C}^{\mathbf{w}(3)} \upharpoonright S_{\mathcal{C}} \subseteq \mathcal{D}^{\mathbf{w}(3)} \upharpoonright S_{\mathcal{D}}$.

Let us show the reverse inclusion. Let $f \in \mathcal{D}^{\mathbf{w}(3)}$ be an i -cell ($i \geq 2$), and suppose that f is in $\mathcal{D}^{\mathbf{w}(3)} \upharpoonright S_{\mathcal{D}}$. In particular $t_2(f)$ and $s_2(f)$ are in $\mathcal{C}_2^{\mathbf{w}}$. Since ι also satisfies the hypotheses of Proposition 3.2.3.11, with $k_0 = 2$, it is 2-discriminating on $\mathcal{D}_i^{\mathbf{w}(3)}$. Thus f is in $\mathcal{C}^{\mathbf{w}(3)}$, and in $\mathcal{C}^{\mathbf{w}(3)} \upharpoonright S_{\mathcal{C}}$ since its 1-target is a normal form. \square

Example 3.3.3.3. In the case where $\mathcal{A} = \mathbf{Assoc}$, the set \mathcal{D}_2 contains one additional 2-cell:

$$\triangle := \bar{\nabla}$$

And the following cells are composites in \mathcal{D}^w :



Note that the equality $\mathcal{D}^{w(3)} \upharpoonright S_{\mathcal{D}} = \mathcal{C}^{w(3)} \upharpoonright S_{\mathcal{C}}$ implies that none of these composites belongs to $\mathcal{D}^{w(3)} \upharpoonright S_{\mathcal{D}}$.

3.3.4 Adjunction of connections between 2-cells

Let \mathcal{E} be the following white 4-polygraph:

- For $i = 0, 1, 2$, $\mathcal{E}_i = \mathcal{D}_i$,
- For $i = 3$, $\mathcal{E}_3 = \mathcal{D}_3 \cup \{\eta_f, \epsilon_f | f \in \mathcal{C}_2\}$.
- For $i = 4$, $\mathcal{E}_4 = \mathcal{D}_4 \cup \{\tau_f, \sigma_f | f \in \mathcal{C}_2\}$.

The cells η_f , ϵ_f , τ_f and σ_f have the following shape:

$$\bullet \epsilon_f : \bar{f} \bullet_1 f \Rrightarrow 1_{t(f)}$$

$$\bullet \eta_f : 1_{s(f)} \Rrightarrow f \bullet_1 \bar{f}$$

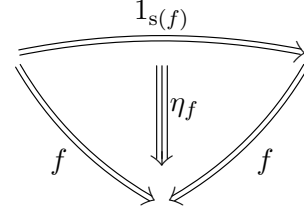
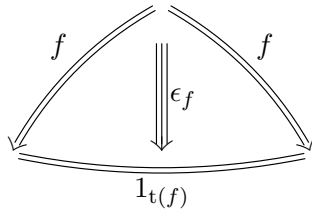

$$\bullet \tau_f : (\bar{f} \bullet_1 \eta_f) \bullet_2 (\epsilon_f \bullet_1 \bar{f}) \Rrightarrow 1_{\bar{f}}$$

$$\begin{array}{ccc} \begin{array}{c} \text{Diagram of } (\bar{f} \bullet_1 \eta_f) \bullet_2 (\epsilon_f \bullet_1 \bar{f}) \end{array} & \xrightarrow{\tau_f} & \begin{array}{c} \text{Diagram of } 1_{\bar{f}} \end{array} \end{array} \quad (3.3.1)$$

$$\bullet \sigma_f : (\eta_f \bullet_1 f) \bullet_2 (f \bullet_1 \epsilon_f) \Rrightarrow 1_f.$$

$$\begin{array}{ccc} \begin{array}{c} \text{Diagram of } (\eta_f \bullet_1 f) \bullet_2 (f \bullet_1 \epsilon_f) \end{array} & \xrightarrow{\sigma_f} & \begin{array}{c} \text{Diagram of } 1_f \end{array} \end{array} \quad (3.3.2)$$

Notation 3.3.4.1. Let us denote by \cup the 3-cell ϵ_f and \cap the 3-cell η_f . Similarly, we denote by \boxplus for σ_f and \boxminus for τ_f :



Let $\mathcal{R} := \{\sigma_f, \tau_f\}$, and $\mathcal{R}^{\mathbf{w}}$ (resp. $\mathcal{R}^{\mathbf{w}(3)}$) be the sub- white 4-category (resp. sub- white (4,3)-category) of $\mathcal{E}^{\mathbf{w}(3)}$ generated by the cells in \mathcal{R} . A 4-cell of length 1 in $\mathcal{R}^{\mathbf{w}}$ is called an \mathcal{R} -rewriting step.

Let $S_{\mathcal{E}}$ be the set of all 2-cells of the sub- white 2-category $\mathcal{C}_2^{\mathbf{w}}$ of $\mathcal{E}_2^{\mathbf{w}}$ whose target is a normal form. Using properties of the rewriting system induced by $\mathcal{R}^{\mathbf{w}}$, we are going to define a functor $K : \mathcal{E}^{\mathbf{w}(3)} \downarrow S_{\mathcal{E}} \rightarrow \mathcal{D}^{\mathbf{w}(3)} \downarrow S_{\mathcal{D}}$.

Lemma 3.3.4.2. *Let $\alpha \in \mathcal{E}_4^{\mathbf{w}}$ and $\beta \in \mathcal{R}^{\mathbf{w}}$ of length 1 with the same source. There exist $\alpha' \in \mathcal{E}_4^{\mathbf{w}}$ and $\beta' \in \mathcal{R}^{\mathbf{w}}$ of maximum length 1, such that:*

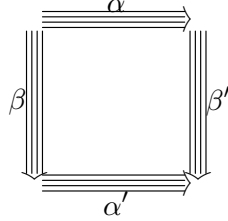

Proof. The result holds whenever (α, β) is a Peiffer or aspherical branching.

If (α, β) is an overlapping branching, then the source of α must contain an η_f or an ϵ_f . The only cells of length 1 in $\mathcal{E}_4^{\mathbf{w}}$ that satisfy this property are those in $\mathcal{R}^{\mathbf{w}}$. Hence, α is in $\mathcal{R}^{\mathbf{w}}$. Thus, the branching (α, β) is one of the following two, and both of them satisfy the required property:

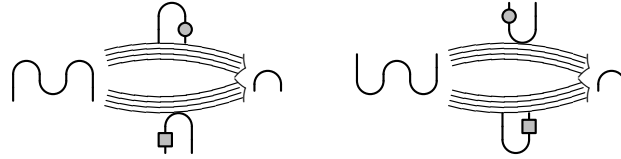

□

Lemma 3.3.4.3. *The rewriting system generated by \mathcal{R} is 4-convergent.*

Proof. Using Lemma 3.3.4.2, the rewriting system generated by \mathcal{R} is locally 4-confluent. Moreover, the cells σ_f and τ_f decrease the length of the 3-cells, hence the 4-termination. □

Let $A \in \mathcal{E}_3^{\mathbf{w}}$: we denote by $\hat{A} \in \mathcal{E}_3^{\mathbf{w}}$ its normal form for \mathcal{R} . Remark in particular that if A is in $\mathcal{D}_3^{\mathbf{w}}$, then $\hat{A} = A$.

Lemma 3.3.4.4. *Let A be a 3-cell of $\mathcal{E}_3^{\mathbf{w}}$ whose target is in $\mathcal{C}_2^{\mathbf{w}}$.*

- *If the source of A is in $\mathcal{C}_2^{\mathbf{w}}$, then \hat{A} is in $\mathcal{D}_3^{\mathbf{w}}$.*
- *Otherwise, for every factorization of A into $f_1 \bullet_1 \bar{f} \bullet_1 f_2$, where f is a rewriting step, there exists a factorisation of A into:*

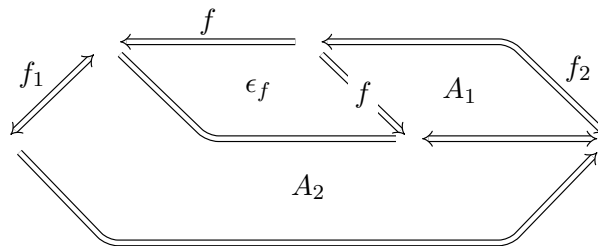

Proof. We reason by induction on the length of A . If A is of length 0, then the source of A is in $\mathcal{C}_2^{\mathbf{w}}$, and $\hat{A} = A$ is in $\mathcal{D}_3^{\mathbf{w}}$.

If A is of length $n > 0$, let us write $A = B_1 \bullet_1 B_2$, where B_1 is of length 1. We can then apply the induction hypothesis to B_2 . We distinguish three cases:

- If both the sources of A and B_2 are in $\mathcal{C}_2^{\mathbf{w}}$, then B_1 is in $\mathcal{D}_3^{\mathbf{w}}$, and so is $\hat{A} = B_1 \bullet_2 \hat{B}_2$.
- If the source of A is in $\mathcal{C}_2^{\mathbf{w}}$ but not that of B_2 , then B_1 is of the form $g_1 \bullet_1 \eta_f \bullet_1 g_2$. There hence exists a factorisation $(g_1 \bullet_1 f) \bullet_1 \bar{f} \bullet_1 g_2$ of the source of B_2 . Applying the induction hypothesis to B_2 , we deduce the following factorisation of A :

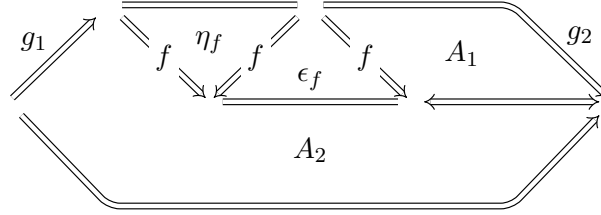

In particular, A is the source of an \mathcal{R} -rewriting step. Let A' be its target, which is thus of length smaller than A . Applying the induction hypothesis to A' , we get that $\hat{A} = \hat{A}'$ is in $\mathcal{D}_3^{\mathbf{w}}$.

- There remains the case where the source of A is not an element of $\mathcal{C}_2^{\mathbf{w}}$.

In order to treat this last case, let us fix a factorisation $f_1 \bullet_1 \bar{f} \bullet_1 f_2$ of the source of A , where f is of length 1. We distinguish three cases depending on the form of B_1 .

- If $B_1 = f_1 \bullet_1 \bar{f} \bullet_1 B'_1$, where B'_1 is a 3-cell of length 1 from f_2 to $g_2 \in \mathcal{D}_2^{\mathbf{w}}$, then we get a factorisation of the source of B into $f_1 \bullet_1 \bar{f} \bullet_1 g_2$. Let us apply the induction hypothesis to B_2 : there exist $A'_1, A'_2 \in \mathcal{E}_3^{\mathbf{w}}$ and $g'_2 \in \mathcal{D}_2^{\mathbf{w}}$ such that:

$$B_2 = (f_1 \bullet_1 \bar{f} \bullet_1 A'_1) \bullet_2 (f_1 \bullet_1 \epsilon_f \bullet_1 g'_2) \bullet_2 A'_2$$

Thus A factorises as follows, which is of the required form by setting $A_1 = B'_1 \bullet_2 A'_1$ and $A_2 = A'_2$:

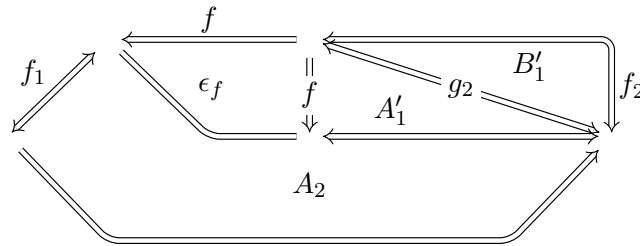

- If $B_1 = B'_1 \bullet_1 \bar{f} \bullet_1 f_2$, where B'_1 is a 3-cell of length 1 from f_1 to $g_1 \in \mathcal{D}_2^{\mathbf{w}}$. Then the source of B factorises into $g_1 \bullet_1 \bar{f} \bullet_1 f_2$. Applying the induction hypothesis to B_2 , there exist $A'_1, A'_2 \in \mathcal{E}_3^{\mathbf{w}}$ and $f'_2 \in \mathcal{D}_2^{\mathbf{w}}$ such that:

$$B_2 = (g_1 \bullet_1 \bar{f} \bullet_1 A'_1) \bullet_2 (g_1 \bullet_1 \epsilon_f \bullet_1 f'_2) \bullet_2 A'_2$$

We get the required factorisation of A by setting $A_1 = A'_1$ and $A_2 = (B'_1 \bullet_1 f'_2) \bullet_2 A'_2$.

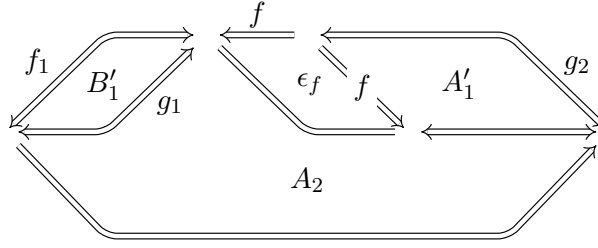

- Otherwise, we have $B_1 = f_1 \bullet_1 \epsilon_f \bullet_1 f'_2$, with $f_2 = f \bullet_1 f'_2$. We then get the required factorisation of A by setting $A_1 = 1_{f'_2}$ and $A_2 = B_2$.

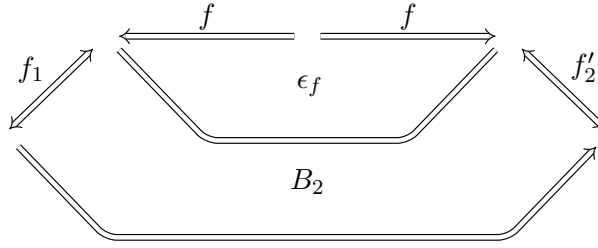

□

Lemma 3.3.4.5. *Let $\beta \in \mathcal{R}^w$, and α be a 4-cell \mathcal{E}_4^w of same source. There exist $\alpha' \in \mathcal{E}_4^w$ and $\beta' \in \mathcal{R}^w$ of maximum length that of β such that we have the following square:*

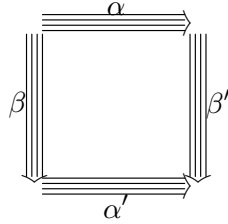

Proof. We reason using a double induction on the lengths of β and α . If β (resp. α) is an identity, then the result holds by setting $\alpha' = \alpha$ (resp. $\beta' = \beta$).

Otherwise, let us write $\alpha = \alpha_1 \bullet_3 \alpha_2$ and $\beta = \beta_1 \bullet_3 \beta_2$, where α_1 and β_1 are of length 1. We can then construct the following diagram:

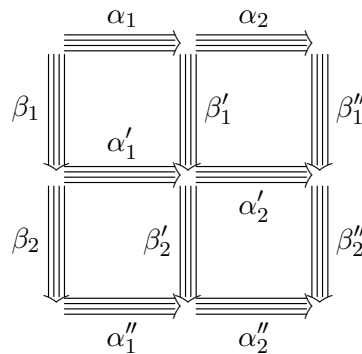

The 4-cells α'_1 and β'_1 exist thanks to Lemma 3.3.4.2. We can then apply the induction hypothesis to the 4-cells α_2 and β'_1 (resp. α'_1 and β_2) and we construct this way the cells α'_2 and β''_1 (resp. α''_1 and β'_2). Lastly, we apply the induction hypothesis to α'_2 et β'_2 in order to construct α''_2 and β''_2 . □

Lemma 3.3.4.6. *The application $A \mapsto \hat{A}$ extends into a 1-functor $K : \mathcal{E}^{\mathbf{w}(3)} \downarrow S_{\mathcal{E}} \rightarrow \mathcal{D}^{\mathbf{w}(3)} \downarrow S_{\mathcal{D}}$, which is the identity on objects.*

Proof. The application $A \mapsto \hat{A}$ does not change the source or target. Moreover, given a 3-cell $A \in \mathcal{E}^{\mathbf{w}(3)}$, if A is in $\mathcal{E}^{\mathbf{w}(3)} \downarrow S_{\mathcal{E}}$ then in particular the source and target of A are in $\mathcal{C}_2^{\mathbf{w}}$. Thus \hat{A} is in $\mathcal{D}_3^{\mathbf{w}} \downarrow S_{\mathcal{D}}$ (Lemma 3.3.4.4).

Let A, B be 3-cells in $\mathcal{E}^{\mathbf{w}(3)}$ which belong to $\mathcal{E}^{\mathbf{w}(3)} \downarrow S_{\mathcal{E}}$. We just showed that \hat{A} and \hat{B} are in $\mathcal{D}_3^{\mathbf{w}} \downarrow S_{\mathcal{D}}$, hence so is $\hat{A} \bullet_2 \hat{B}$. So $\hat{A} \bullet_2 \hat{B}$ is a normal form for \mathcal{R} which is attainable from $A \bullet_2 B$. Since \mathcal{R} is 4-convergent, this means that $\widehat{A \bullet_2 B} = \hat{A} \bullet_2 \hat{B}$. So $A \mapsto \hat{A}$ does indeed define a functor. \square

Proposition 3.3.4.7. *The pointed (4, 3)-category $(\mathcal{E}, S_{\mathcal{E}})$ is stronger than $(\mathcal{D}, S_{\mathcal{D}})$.*

Proof. Let us show that K induces a functor $\bar{K} : \overline{\mathcal{E}^{\mathbf{w}(3)} \downarrow S_{\mathcal{E}}} \rightarrow \overline{\mathcal{D}^{\mathbf{w}(3)} \downarrow S_{\mathcal{D}}}$. Let A, B be 1-cells in $\mathcal{E}^{\mathbf{w}(3)} \downarrow S_{\mathcal{E}}$, and suppose $\bar{A} = \bar{B}$. Let us show that $\overline{K(A)} = \overline{K(B)}$, that is that there exists a 4-cell $\alpha' : \hat{A} \Rrightarrow \hat{B} \in \mathcal{D}_4^{\mathbf{w}(3)}$.

Since $\bar{A} = \bar{B}$ there exists a 4-cell $\alpha : A \Rrightarrow B \in \mathcal{E}_4^{\mathbf{w}(3)}$. Suppose that α lies in $\mathcal{E}_4^{\mathbf{w}}$. Let $\beta \in \mathcal{R}^{\mathbf{w}}$ be a cell from A to \hat{A} . Applying Lemma 3.3.4.5 to α and β , we get cells α' and β' of sources respectively \hat{A} and B . Let B' be their common target. By hypothesis \hat{A} is in $\mathcal{D}_3^{\mathbf{w}}$, and the only cells in $\mathcal{E}_4^{\mathbf{w}}$ whose source is in $\mathcal{D}_3^{\mathbf{w}}$ are the cells in $\mathcal{D}_4^{\mathbf{w}}$. Thus α' is in $\mathcal{D}_4^{\mathbf{w}}$, and so is B' . So B' is a normal form for $\mathcal{R}^{\mathbf{w}}$ which is attainable from B . By unicity of the $\mathcal{R}^{\mathbf{w}}$ -normal-form, $B' = \hat{B}$, and so α' is a cell in $\mathcal{D}_4^{\mathbf{w}}$ of source $K(A)$ and of target $K(B)$, hence $\overline{K(A)} = \overline{K(B)}$.

In general if $\bar{A} = \bar{B}$, there exist $A_1, \dots, A_n \in \mathcal{E}_3^{\mathbf{w}}$ with $A_1 = A, B_n = B$ and for every i there exist cells $\alpha_i : A_{2i} \Rrightarrow A_{2i-1}$ and $\beta_i : A_{2i} \rightarrow A_{2i+1}$ in $\mathcal{E}_4^{\mathbf{w}}$. Hence, using the previous case $\overline{K(A_1)} = \dots = \overline{K(A_n)}$, that is $K(A_1) = K(A_n)$.

So $\bar{K} : \overline{\mathcal{E}^{\mathbf{w}(3)} \downarrow S_{\mathcal{E}}} \rightarrow \overline{\mathcal{D}^{\mathbf{w}(3)} \downarrow S_{\mathcal{D}}}$ is well-defined, and it is 0 and 1-surjective because K is. Hence, $(\mathcal{E}, S_{\mathcal{E}})$ is stronger than $(\mathcal{D}, S_{\mathcal{D}})$. \square

Example 3.3.4.8. In the case where $\mathcal{A} = \mathbf{Assoc}$, let $A = \nabla$. The set \mathcal{E}_3 contains the following 3-cells:

$$\begin{array}{ccc} \begin{array}{c} \diamond \\ \parallel \\ \diamond \end{array} & \xRightarrow{\epsilon_A} & | \\ & & | \\ & & \xRightarrow{\eta_A} & \begin{array}{c} \nabla \\ \parallel \\ \nabla \end{array} \end{array}$$

And the set \mathcal{E}_4 the following 4-cells:

$$\begin{array}{ccc} \begin{array}{c} \diamond \\ \parallel \\ \diamond \end{array} & & \begin{array}{c} \nabla \\ \parallel \\ \nabla \end{array} \\ \eta_A \nearrow & & \eta_A \nearrow \\ \parallel & & \parallel \\ \epsilon_A \searrow & & \epsilon_A \searrow \\ \begin{array}{c} \triangle \\ \parallel \\ \triangle \end{array} & \xRightarrow{\tau_A} & \begin{array}{c} \triangle \\ \parallel \\ \triangle \end{array} \\ & & \sigma_A \end{array}$$

3.3.5 Reversing the presentation of a white (4, 3)-category

We start by collecting some results on the cells of \mathcal{E} .

Lemma 3.3.5.1. *The set \mathcal{E}_3 is composed exactly of the following cells:*

- For every $f \in \mathcal{A}_2$, 3-cells η_f and ϵ_f .

- For every non-aspherical minimal branching (f, g) , a 3-cell $A_{f,g}$ of shape:

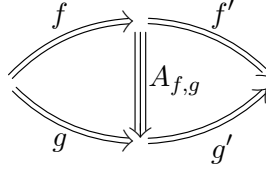

And in particular for every non-aspherical minimal branching (f, g) , we have $A_{f,g}^{op} = A_{g,f}$.

Proof. If (f, g) is a critical pair: if it was associated to a 3-cell in \mathcal{A} then $A_{f,g}$ is this corresponding cell. Otherwise, $A_{f,g}$ is in fact the cell $A_{g,f}^{op}$ from Section 3.3.2.

If (f, g) is a strict Peiffer branching, then $A_{f,g}$ is the cell defined in Section 3.3.1. Otherwise, (g, f) is a strict Peiffer branching, and we set $A_{f,g} := A_{g,f}^{op}$ from Section 3.3.2. \square

Lemma 3.3.5.2. For every minimal non-aspherical branching (f, g, h) , there exists a 4-cell $A_{f,g,h} \in \mathcal{E}_4^{w(3)}$ of the following shape:

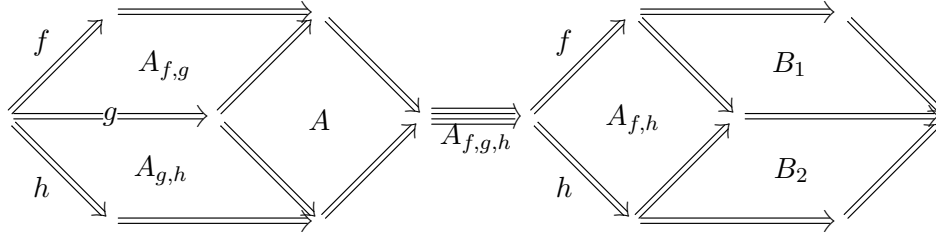

Proof. Let us first start by showing that, for every non-aspherical 3-fold minimal symmetrical branching b , there exists a representative (f, g, h) of b for which the property holds. If b is an overlapping branching then, using the fact that \mathcal{A} satisfies the 2-Squier condition of depth 2, the cell $A_{f,g,h}$ exists for some representative (f, g, h) of b . Otherwise, b is a Peiffer branching, and we conclude using the cells defined in Section 3.3.1.

It remains to show that the set of all branchings satisfying the property is closed under the action of the symmetric group.

- If (f_1, f_2, f_3) satisfies the property, then so does (f_3, f_2, f_1) . Indeed, let $A := A_{f_1, f_2, f_3}$, and let us denote its source by s and its target by t , all we need to construct is a 4-cell from s^{op} to t^{op} . This is given by the following composite:

$$s^{op} \xRightarrow{s^{op} \bullet \lambda_t^{-1}} t^{op} \bullet t \bullet s^{op} \xRightarrow{t^{op} \bullet A^{-1} \bullet s^{op}} t^{op} \bullet s \bullet s^{op} \xRightarrow{t^{op} \bullet \rho_s} t^{op}$$

- If (f_1, f_2, f_3) satisfies the property, then so does (f_2, f_1, f_3) . Indeed, given a cell A_{f_1, f_2, f_3} ,

we can construct the following composite:

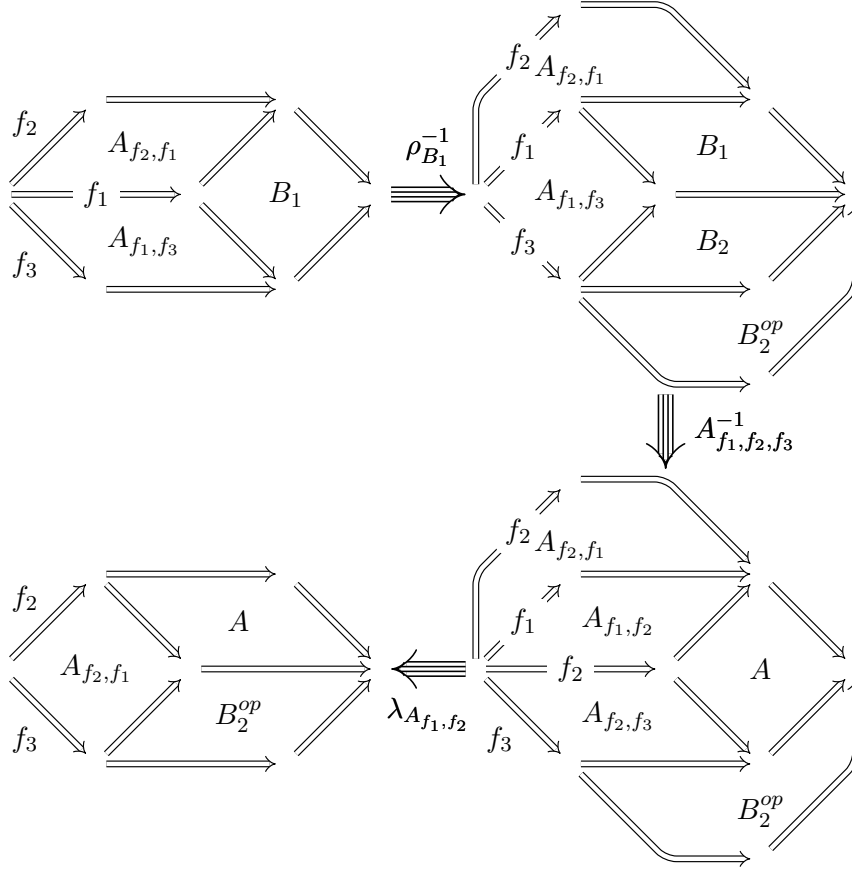

Since the transpositions (1 2) and (1 3) generate the symmetric group, the set of all branchings satisfying the property is closed under the action of the symmetric group. \square

We are now going to apply a series of Tietze-transformations to \mathcal{E} in order to mimic a technique known as *reversing*. Reversing is a combinatorial tool to study presented monoids [26]. Reversing is particularly adapted to monoids whose presentation contains no relation of the form $su = sv$, where s is a generator and u and v words in the free monoid, and at most one relation of the form $su = s'v$, for s and s' generators. The $(4, 2)$ -polygraph \mathcal{A} satisfies those properties, but only up to a dimensional shift: there are no 3-cell in \mathcal{A}_3 of the form $f \bullet_2 g \Rightarrow f \bullet_2 h$, where f is of length 1 and g and h are in \mathcal{A}_2^w , and there is at most one 3-cell in \mathcal{A}_3 of the form $f \bullet_2 g \Rightarrow f' \bullet_2 h$, where f and f' are of length 1. Hence, we adapt this method to our higher-dimensional setting.

Adjunction of 3-cells $C_{f,g}$ with its defining 4-cell $X_{f,g}$. For every non-aspherical branching (f, g) , we add a 3-cell $C_{f,g}$ of the following shape:

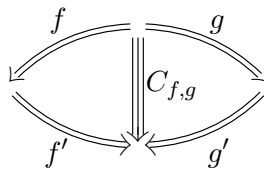

using as defining 4-cell a cell $X_{f,g}$ whose target is $C_{f,g}$ and whose source is the composite:

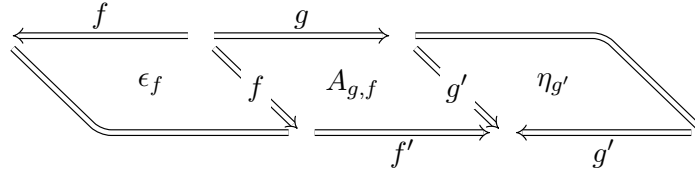

Adjunction of a superfluous 4-cell $Y_{f,g}$. We add a 4-cell $Y_{f,g}$ of target $A_{g,f}$, parallel to the following 4-cell (where the second step consists in the parallel application of σ_f and $\sigma_{g'}$):

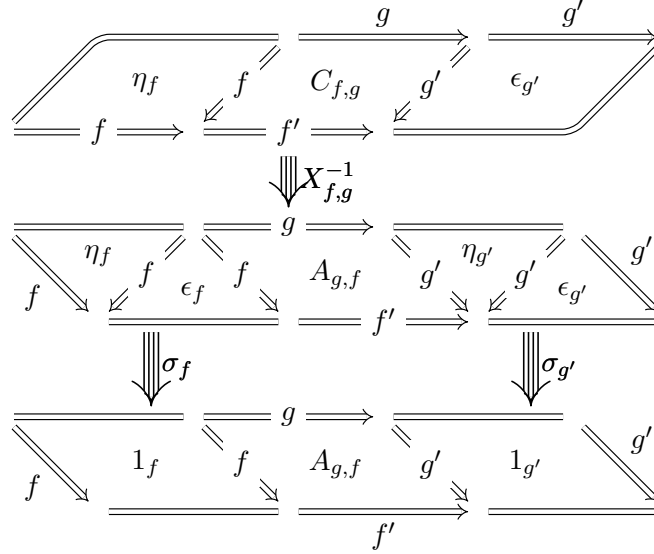

Removal of the superfluous 4-cell $X_{f,g}$. We remove the 4-cell $X_{f,g}$, using the fact that it is parallel to the following composite:

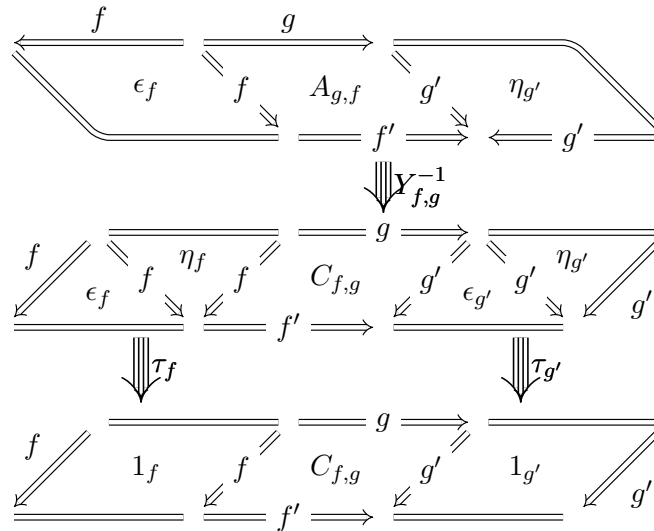

Removal of the 3-cell $A_{g,f}$ with its defining 4-cell $Y_{f,g}$. This last step is possible because $A_{g,f}$ is the target of $Y_{f,g}$ and does not appear in its source.

We denote by \mathcal{F} the white 4-polygraph obtained after performing this series of Tietze-transformations for every non-aspherical branching (f, g) , and $\Pi : \mathcal{E}^{\mathbf{w}(3)} \rightarrow \mathcal{F}^{\mathbf{w}(3)}$ the white 3-functor induced by the Tietze-transformations. We still denote by $A_{g,f}$ the composite in $\mathcal{F}_4^{\mathbf{w}(3)}$, image by Π of $A_{f,g} \in \mathcal{E}_4$.

Example 3.3.5.3. In the case where $\mathcal{A} = \mathbf{Assoc}$, the cells ∇ and ∇^{op} respectively associated to the branchings $(\nabla \mid , \mid \nabla)$ and $(\mid \nabla , \nabla \mid)$ have been replaced by cells of the following shape:

$$\begin{array}{ccc} \begin{array}{c} \diagup \quad \diagdown \\ \diagdown \quad \diagup \end{array} & \Longrightarrow & \begin{array}{c} \diagdown \quad \diagup \\ \diagup \quad \diagdown \end{array} \end{array} \quad \begin{array}{ccc} \begin{array}{c} \diagdown \quad \diagup \\ \diagup \quad \diagdown \end{array} & \Longrightarrow & \begin{array}{c} \diagup \quad \diagdown \\ \diagdown \quad \diagup \end{array} \end{array}$$

3.4 Proof of Theorem 3.1.3.5

This Section concludes the proof of Theorem 3.1.3.5. We keep the notations from Section 3.3. In Section 3.4.1, we study the 4-cells of the white $(4, 3)$ -category $\mathcal{F}^{\mathbf{w}(3)}$, and in particular study the consequences of \mathcal{A} satisfying the 2-Squier condition of depth 2.

In Section 3.4.2, we define a well-founded ordering on $\mathbb{N}[\mathcal{F}_1^{\mathbf{w}}]$, the free commutative monoid on $\mathcal{F}_1^{\mathbf{w}}$. Using this ordering together with two applications $\mathbf{p} : \mathcal{F}_2^{\mathbf{w}} \rightarrow \mathbb{N}[\mathcal{F}_1^{\mathbf{w}}]$ and $\mathbf{w}_\eta : \mathcal{F}_3^{\mathbf{w}} \rightarrow \mathbb{N}[\mathcal{F}_1^{\mathbf{w}}]$, we proceed to complete the proof by induction in Section 3.4.3.

3.4.1 Local coherence

Definition 3.4.1.1. We extend the notation $C_{f,g}$ from Section 3.3.5 by defining, for every local branching (f, g) of $\mathcal{B}_2^{\mathbf{w}}$, a 3-cell of the form $C_{f,g} : \bar{f} \bullet_1 g \Rightarrow f' \bullet_1 \bar{g}' \in \mathcal{F}_3^{\mathbf{w}}$, where f' and g' are in $\mathcal{B}_2^{\mathbf{w}}$.

- If (f, g) is a minimal overlapping or Peiffer branching, then $C_{f,g}$ is already defined.
- If (f, g) is aspherical, that is $f = g$, then we set $C_{f,f} = \epsilon_f$.
- If (f, g) is not minimal, then let us write $(f, g) = (u\tilde{f}v, u\tilde{g}v)$, with (\tilde{f}, \tilde{g}) a minimal branching, and we set $C_{f,g} := uC_{\tilde{f},\tilde{g}}v$.

Definition 3.4.1.2. We say that a 3-fold local branching (f, g, h) of \mathcal{A}_2 is *coherent* if there exists a 4-cell $C_{f,g,h} \in \mathcal{F}_4^{\mathbf{w}(3)}$ of the following shape, where A and B are 4-cells in $\mathcal{F}_3^{\mathbf{w}}$.

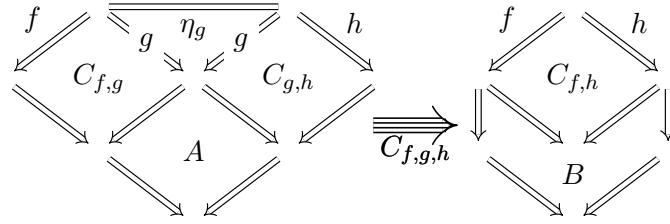

Lemma 3.4.1.3. Every 3-fold local branching of $\mathcal{B}_2^{\mathbf{w}}$ is coherent.

Proof. Let (f, g, h) be a minimal local branching. We first treat the case where (f, g, h) is an aspherical branching. If $f = g$, then $C_{f,g} = \epsilon_f$, and the following cell shows that the branching is coherent:

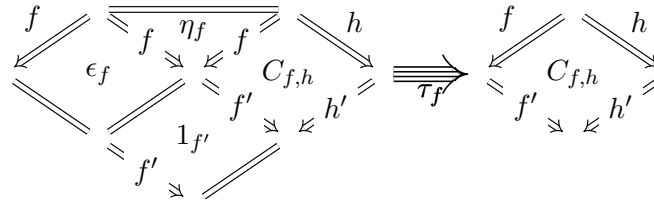

The case where $g = h$ is symmetrical. Assume now $g \neq f, h$ and $f = h$. Then (f, g) is either an overlapping or a Peiffer branching. In any case there exists either a cell $A_{f,g}$ or $A_{g,f}$ in $\mathcal{E}_3^{\mathbf{w}}$. In the former case, we can construct the following cell in $\mathcal{F}_4^{\mathbf{w}(3)}$.

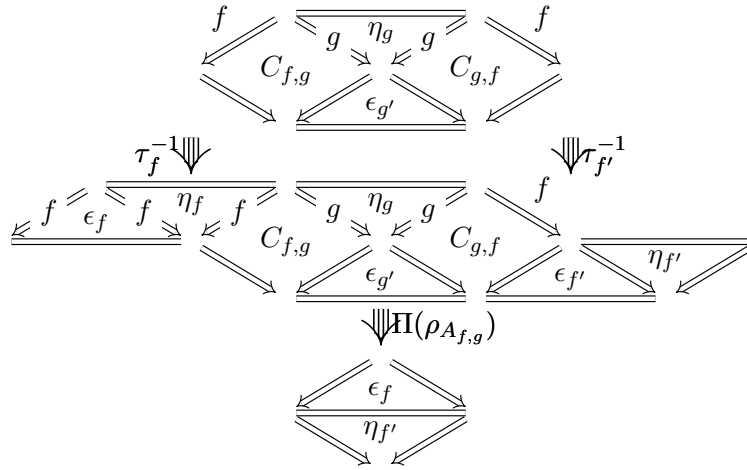

In the latter, we can construct the same cell, only replacing $\Pi(\rho_{A_{f,g}})$ by $\Pi(\lambda_{A_{f,g}})$.

Suppose now that (f, g, h) is not aspherical. Using the cell $A_{f,g,h}$ described in Lemma 3.3.5.2, we build the following composite in $\mathcal{F}_4^{\mathbf{w}(3)}$:

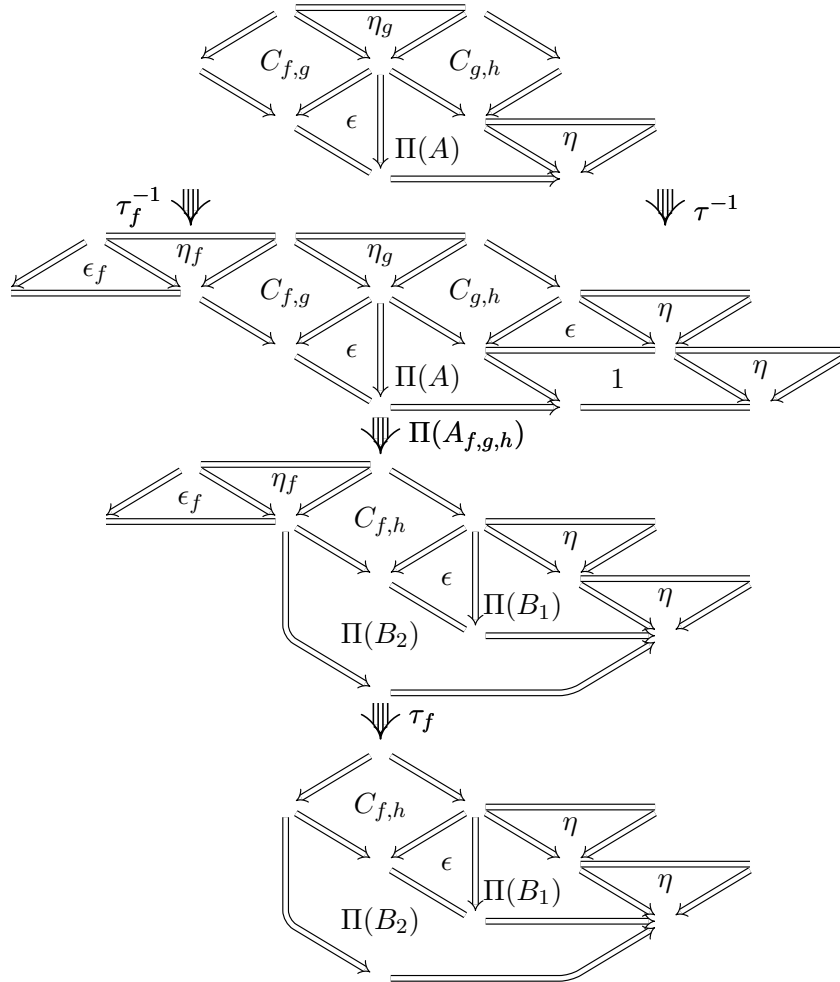

Finally, if (f, g, h) is not aspherical, then there exists a 3-fold minimal branching $(\tilde{f}, \tilde{g}, \tilde{h})$ of $\mathcal{B}_2^{\mathbf{w}}$ and 1-cells $u, v \in \mathcal{B}_1^{\mathbf{w}}$ such that $(f, g, h) = (u\tilde{f}v, u\tilde{g}v, u\tilde{h}v)$. Then the cell $uC_{\tilde{f},\tilde{g},\tilde{h}}v$ shows

that (f, g, h) is coherent. □

3.4.2 Orderings on the cells of \mathcal{F}^w

Definition 3.4.2.1. Let E be a set. The set of all finite multi-sets on E is $\mathbb{N}[E]$, the free commutative monoid over E . For every $e \in E$, let $\mathbf{v}_e : \mathbb{N}[E] \rightarrow \mathbb{N}$ be the morphism of monoids that sends e to 1 and every other elements of E to 0.

If E is equipped with a strict ordering $>$, we denote by $>_m$ the strict ordering on $\mathbb{N}[E]$ defined as follows: for every $f, g \in \mathbb{N}[E]$, one has $f >_m g$ if

- $f \neq g$
- For every $e \in E$, if $\mathbf{v}_e(f) < \mathbf{v}_e(g)$, then there exists $e' > e$ such that $\mathbf{v}_{e'}(f) > \mathbf{v}_{e'}(g)$.

Lemma 3.4.2.2. Let E be a set and $a \in E$. The set of all $f \in \mathbb{N}[E]$ such that $f < a$ is equal to the set of all $f \in \mathbb{N}[E]$ satisfying the following implication for every $b \in E$:

$$\mathbf{v}_b(f) > 0 \Rightarrow b < a.$$

In particular, this set is a sub-monoid of $\mathbb{N}[E]$.

Proof. Let $f \in \mathbb{N}[E]$ such that for every $b \in E$ the implication $\mathbf{v}_b(f) > 0 \Rightarrow b < a$ is verified. Let us prove that $f <_m a$. Necessarily $\mathbf{v}_a(f) = 0$, otherwise we would have $a < a$. Thus, in particular $f \neq a$. Moreover, let $b \in E$ such that $\mathbf{v}_b(f) > \mathbf{v}_b(a) \geq 0$. By definition of f this implies that $b < a$, and since $0 = \mathbf{v}_a(f) < \mathbf{v}_a(a) = 1$ we get that $f <_m a$.

Conversely, let $f <_m a$. Let us show by contradiction that $\mathbf{v}_a(f) = 0$. If $\mathbf{v}_a(f) \neq 0$, we distinguish two cases:

- If $\mathbf{v}_a(f) = 1$, then since $f \neq a$, there exists $b \neq a \in E$ such that $\mathbf{v}_b(f) > 0$. Thus, because $f < a$, there exists $c > b \in E$ such that $\mathbf{v}_c(f) < \mathbf{v}_c(a)$. So we necessarily have $\mathbf{v}_c(a) \geq 1$, which implies that $c = a$. The condition $\mathbf{v}_c(f) < \mathbf{v}_c(a)$ thus becomes $\mathbf{v}_a(f) < 1$, which contradicts the hypothesis that $\mathbf{v}_a(f) = 1$.
- If $\mathbf{v}_a(f) > 1$, then there exists $b > a$ such that $\mathbf{v}_b(a) > \mathbf{v}_b(f)$, which is impossible.

Hence, necessarily $\mathbf{v}_a(f) = 0$.

Let $b \in E$ such that $\mathbf{v}_b(f) > 0$, and let us show that $b < a$. We just showed that $b \neq a$, and so $\mathbf{v}_b(f) > \mathbf{v}_b(a)$. Thus, there exists $c > b$ such that $\mathbf{v}_c(a) > \mathbf{v}_c(f)$. In particular this implies $\mathbf{v}_c(a) > 0$. So $c = a$ and finally $a > b$. □

Lemma 3.4.2.3. Let $(E, <)$ be a set equipped with a strict ordering. The relation $>_m$ is compatible with the monoidal structure on $\mathbb{N}(E)$, that is, for every $f, f', g \in \mathbb{N}(E)$, if $f >_m f'$, then $f + g >_m f' + g$.

Proof. Let $f, f', g \in \mathbb{N}(E)$, and suppose that $f >_m f'$. Let us show that $f + g >_m f' + g$. Firstly, $f \neq f'$, hence $f + g \neq f' + g$.

Let $e \in E$ such that $\mathbf{v}_e(f + g) < \mathbf{v}_e(f' + g)$. Since \mathbf{v}_e is a morphism of monoids, this implies that $\mathbf{v}_e(f) < \mathbf{v}_e(f')$. Hence, there exists $e' > e$ such that $\mathbf{v}_{e'}(f) > \mathbf{v}_{e'}(f')$, and so $\mathbf{v}_{e'}(f + g) > \mathbf{v}_{e'}(f' + g)$ □

The proof of the following theorem can be found in [4].

Theorem 3.4.2.4. Let $(E, >)$ be a set equipped with a strict ordering. Then $>_m$ is a well-founded ordering if and only if $>$ is.

Since \mathcal{A} is 2-terminating, the set \mathcal{A}_1^* is equipped with a well-founded ordering \Rightarrow . This induces a well-founded ordering \Rightarrow_m on $\mathbb{N}[\mathcal{A}_1^*]$. We now define two applications $\mathbf{p} : \mathcal{F}_2^{\mathbf{w}} \rightarrow \mathbb{N}[\mathcal{A}_1^*]$ and $\mathbf{w}_\eta : \mathcal{F}_3^{\mathbf{w}} \rightarrow \mathbb{N}[\mathcal{A}_1^*]$. Using \Rightarrow_m , those applications induce well-founded orderings on $\mathcal{F}_2^{\mathbf{w}}$ and $\mathcal{F}_3^{\mathbf{w}}$. We then show a number of properties of these applications in preparation for Section 3.2.2.

Definition 3.4.2.5. We define an application $\mathbf{p} : \mathcal{F}_2^{\mathbf{w}} \rightarrow \mathbb{N}[\mathcal{A}_1^*]$:

- for every $f \in \mathcal{F}_2^{\mathbf{w}}$ of length 1, we set $\mathbf{p}(f) := s(f) + t(f)$,
- for every composable $f_1, f_2 \in \mathcal{F}_2^{\mathbf{w}}$, we set $\mathbf{p}(f_1 \bullet_1 f_2) := \mathbf{p}(f_1) + \mathbf{p}(f_2)$.

For every $f, g \in \mathcal{F}_2^{\mathbf{w}}$, we set $f > g$ if $\mathbf{p}(f) \Rightarrow_m \mathbf{p}(g)$. The relation $>$ is a well-founded ordering of $\mathcal{F}_2^{\mathbf{w}}$.

Definition 3.4.2.6. We define an application $\mathbf{w}_\eta : \mathcal{F}_3^{\mathbf{w}} \rightarrow \mathbb{N}[\mathcal{A}_1^*]$ by setting:

- For every $f \in \mathcal{B}_2^{\mathbf{w}}$ of length 1, $\mathbf{w}_\eta(\eta_f) = s(f)$.
- For every 3-cell $A \in \mathcal{F}_3$ and $u, v \in \mathcal{A}_1^*$, if A is not an η_f then $\mathbf{w}_\eta(uAv) = 0$.
- For every $f_1, f_2 \in \mathcal{F}_2^{\mathbf{w}}$ and $A \in \mathcal{F}_3^{\mathbf{w}}$, $\mathbf{w}_\eta(f_1 \bullet_1 A \bullet_1 f_2) = \mathbf{w}_\eta(A)$.
- For every $A_1, A_2 \in \mathcal{F}_3^{\mathbf{w}}$, $\mathbf{w}_\eta(A_1 \bullet_2 A_2) = \mathbf{w}_\eta(A_1) + \mathbf{w}_\eta(A_2)$.

Definition 3.4.2.7. A product of the form $\bar{f} \bullet_1 g \in \mathcal{F}_2^{\mathbf{w}}$, where f and g are nonempty cells in $\mathcal{B}_2^{\mathbf{w}}$ is called a *cavity*. It is a *local cavity* if f and g are of length 1. Let $C_{\mathcal{F}}$ be the set of all cavities.

Lemma 3.4.2.8. Let $f, g \in \mathcal{B}_2^{\mathbf{w}}$. Suppose f is not an identity and $t(f) = s(g)$. The following inequality holds:

$$s(f) > \mathbf{p}(g)$$

Proof. We reason by induction on the length of g . If g is empty, then $\mathbf{p}(g) = 0 < s(f)$.

Otherwise, let us write $g = g_1 \bullet_1 g_2$, with g_1 of length 1. Then $\mathbf{p}(g) = \mathbf{p}(g_1) + \mathbf{p}(g_2)$ and by induction hypothesis $\mathbf{p}(g_2) < s(f \bullet_1 g_1) = s(f)$. Moreover, we have $f : s(f) \Rightarrow s(g_1)$ and $f \bullet_1 g_1 : s(f) \Rightarrow t(g_1)$. Hence, $s(f) > \mathbf{p}(g_1), s(g_2), t(g_2)$ and, by Lemma 3.4.2.2, we get $s(f) > \mathbf{p}(g_1) + s(g_2) + t(g_2) = \mathbf{p}(g)$. □

Lemma 3.4.2.9. Let $f_1, f_2, g_1, g_2 \in \mathcal{B}_2^{\mathbf{w}}$, with f_1 and f_2 non-empty and of same source u . For every 3-cell $A : f_1 \bullet_1 f_2 \Rightarrow g_1 \bullet_1 g_2 \in \mathcal{F}_3^{\mathbf{w}}$, the following inequalities hold:

$$\mathbf{p}(s(A)) > u > \mathbf{p}(t(A)).$$

In particular for every cell $C_{f,g}$, we have $s(C_{f,g}) > t(C_{f,g})$.

Proof. Considering the first inequality, we have $\mathbf{p}(s(A)) = \mathbf{p}(f_1) + \mathbf{p}(g_2) \geq 2u > u$.

Considering the second one, using Lemma 3.4.2.8, we have the inequalities $u = s(f_1) > \mathbf{p}(g_1)$ and $u = s(f_2) > \mathbf{p}(g_2)$. By 3.4.2.2, we then have $u > \mathbf{p}(g_1) + \mathbf{p}(g_2) = \mathbf{p}(t(A))$. □

Definition 3.4.2.10. Let $h \in \mathcal{F}_2^{\mathbf{w}}$. A factorisation $h = h_1 \bullet_1 \bar{f}_1 \bullet_1 f_2 \bullet_1 h_2$ of h , with $f_1, f_2 \in \mathcal{B}_2^{\mathbf{w}}$ of length 1 and $h_1, h_2 \in \mathcal{F}_2^{\mathbf{w}}$ is called a *cavity-factorisation* of h . Thus, a cavity-factorisation is represented as follows:

$$\begin{array}{ccccc} & & f_1 & & f_2 & & \\ & & // & & \backslash & & \\ \leftarrow h_1 & & & & & & \leftarrow h_2 \rightarrow \end{array}$$

Lemma 3.4.2.11. *Let $h \in \mathcal{F}_2^{\mathbf{w}}$ be a 2-cell which is not an identity, and whose source and target are a normal form for \mathcal{A}_2 . Then there exists a cavity-factorisation of h .*

Proof. By definition of $\mathcal{F}_2^{\mathbf{w}}$, there exist $n \in \mathbb{N}^*$ and $g_1, \dots, g_{2n} \in \mathcal{B}_2^{\mathbf{w}}$ all not identities, except possibly g_1 or g_{2n} , such that $h = \bar{g}_1 \bullet_1 g_2 \bullet_1 \dots \bullet_1 \bar{g}_{2n-1} \bullet_1 g_{2n}$.

Let us show that g_1 and g_{2n} are not identities:

- If g_1 is an identity, then since h isn't, either $n \geq 2$ or $n = 1$ and g_{2n} is not an identity. In both cases g_2 is of length at least 1, and has $s(h)$ as target, which contradicts the fact that $s(h)$ is a normal form for \mathcal{A}_2 .
- The case where g_{2n} is an identity is symmetric.

Therefore, the 2-cells g_1 and g_2 are of length at least 1. So we can write $g_1 = f_1 \bullet_1 g'_1$ and $g_2 = f_2 \bullet_1 g'_2$, with $f_1, f_2 \in \mathcal{B}_2^{\mathbf{w}}$ of length 1. Let $h_1 := \bar{g}'_1$ and $h_2 := g'_2 \bullet_1 \bar{g}_3 \bullet_1 g_4 \bullet_1 \dots \bullet_1 \bar{g}_{2n-1} \bullet_1 g_{2n}$. We finally get: $h = h_1 \bullet_1 \bar{f}_1 \bullet_1 f_2 \bullet_1 h_2$. \square

Lemma 3.4.2.12. *Let $h \in \mathcal{F}_2^{\mathbf{w}}$ be a 2-cell of source and target \hat{u} , a normal form for \mathcal{A}_2 . There exists a 3-cell $A : h \Rightarrow 1_{\hat{u}}$ such that $\mathbf{w}_\eta(A) = 0$.*

Proof. We reason by induction on h using the ordering $>$. If h is minimal, then $h = 1_{\hat{u}}$ and we can set $A := 1_h$.

Otherwise, by Lemma 3.4.2.11 there exists a cavity-factorisation $h = h_1 \bullet_1 f_1 \bullet_1 f_2 \bullet_1 h_2$ of h . Let $A_1 := C_{f_1, f_2}$: we have $\mathbf{w}_\eta(A_1) = 0$ and by Lemma 3.4.2.9, $s(A_1) > t(A_1)$. Since the ordering is compatible with composition, we get $h > h_1 \bullet_1 t(A_1) \bullet_1 h_2$. By induction hypothesis, there exists a 3-cell $A_2 : h_1 \bullet_1 t(A_1) \bullet_1 h_2 \Rightarrow 1_{\hat{u}} \in \mathcal{F}_3^{\mathbf{w}}$ such that $\mathbf{w}_\eta(A_2) = 0$.

Let $A := (h_1 \bullet_1 A_1 \bullet_1 h_2) \bullet_1 A_2$. We have $\mathbf{w}_\eta(A) = \mathbf{w}(h_1 \bullet_1 A_1 \bullet_1 h_2) + \mathbf{w}(A_2) = \mathbf{w}(A_1) + 0 = 0$. \square

Lemma 3.4.2.13. *Let $h \in \mathcal{F}_2^{\mathbf{w}}$ of source and target \hat{u} a normal form for \mathcal{A}_2 , and $A : h \Rightarrow 1_{\hat{u}} \in \mathcal{F}_3^{\mathbf{w}}$. For every cavity-factorisation $h = h_1 \bullet_1 \bar{f}_1 \bullet_1 f_2 \bullet_1 h_2$, there exists a factorisation of $A = (h_1 \bullet_1 A_1 \bullet_1 h_2) \bullet_2 A_2$, with $A_1, A_2 \in \mathcal{F}_3^{\mathbf{w}}$, and either $A_1 = C_{f_1, f_2}$ or $A_1 = \bar{f}_1 \bullet_1 \eta_{f_3} \bullet_1 f_2$, with $f_3 \in \mathcal{B}_2^{\mathbf{w}}$ of length 1.*

Proof. We reason by induction on the length of A . If A is of length 0, then there is no cavity-factorisation of $h = 1_{\hat{u}}$ and the result holds.

If A is not of length 0, let $h = h_1 \bullet_1 \bar{f}_1 \bullet_1 f_2 \bullet_1 h_2$ be a cavity-factorisation of h . Let us write $A = B \bullet_1 C$, where B is of length 1. If B is not of the required form, then either $B = B' \bullet_1 \bar{f}_1 \bullet_1 f_2 \bullet_1 h_2$, or $B = h_1 \bullet_1 \bar{f}_1 \bullet_1 f_2 \bullet_1 B'$. Let us treat the first case, the second being symmetrical. The source of C admits a cavity-factorisation $s(C) = t(B') \bullet_1 \bar{f}_1 \bullet_1 f_2 \bullet_1 h_2$. By induction hypothesis, we can factorise C as follows:

$$C = (h'_1 \bullet_1 A_1 \bullet_1 h_2) \bullet_2 C',$$

with $A_1 = C_{f_1, f_2}$ or $A_1 = \bar{f}_1 \bullet_1 \eta_{f_3} \bullet_1 f_2$. Let $A_2 := (B'_1 \bullet_1 t(A_1) \bullet_1 h_2) \bullet_2 C_2$: we then have $A = (h_1 \bullet_1 A_1 \bullet_1 h_2) \bullet_2 A_2$.

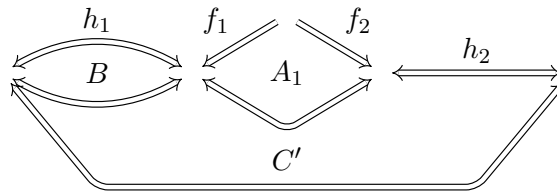

\square

Lemma 3.4.2.14. *Let $h \in \mathcal{F}_2^{\mathbf{w}}$ and $u \in \mathcal{A}_1^*$ such that $u > \mathbf{p}(h)$, $u > s(h)$ and $u > t(h)$. For every 3-cell $A \in \mathcal{F}_3^{\mathbf{w}}$ of source h , the inequality $u > \mathbf{w}_\eta(A)$ holds.*

Proof. We reason by induction on the length of A . If A is of length 0, $\mathbf{w}_\eta(A) = 0$ and the result holds.

Otherwise, let us write $A = A_1 \bullet_2 A_2$, with A_1 of length 1. We distinguish two cases depending on the shape of A_1 .

- If $A_1 = h_1 \bullet_1 \eta_f \bullet_1 h_2$, with $h_1, h_2 \in \mathcal{F}_2^{\mathbf{w}}$ and $f \in \mathcal{B}_2^{\mathbf{w}}$ of length 1.

If h_1 and h_2 are empty, then $s(A_2) = f \bullet_1 \bar{f}$. Thus $\mathbf{p}(s(A_2)) = 2s(f) + 2t(f) \leq 4s(f) = 4s(h)$. Since $s(h) < u$, using Lemma 3.4.2.2, we get that $\mathbf{p}(s(A_2)) < u$. Applying the induction hypothesis to A_2 , we get $\mathbf{w}_\eta(A_2) < u$. Moreover, $\mathbf{w}_\eta(A) = \mathbf{w}_\eta(A_1) + \mathbf{w}_\eta(A_2) = s(f) + \mathbf{w}_\eta(A_2)$, and we showed that $\mathbf{w}_\eta(A_2) < u$ and $s(f) = s(h) < u$. Thus, according to Lemma 3.4.2.2 we get $\mathbf{w}_\eta(A) < u$.

Otherwise, suppose for example that h_1 is not an identity (the case where h_2 is not an identity being symmetrical). Then we have $\mathbf{v}_{t(h_1)}(\mathbf{p}(h_1)) > 0$, so $\mathbf{v}_{t(h_1)}(\mathbf{p}(h)) > 0$. Since $\mathbf{p}(h) < u$, we have by Lemma 3.4.2.2 that $s(f) = t(h_1) < u$. So $\mathbf{p}(s(A_2)) = \mathbf{p}(h_1) + \mathbf{p}(h_2) + 2s(f) + 2t(f) < \mathbf{p}(h) + 4s(f) < u$. By induction hypothesis, we thus have $\mathbf{w}_\eta(A_2) < u$, and finally $\mathbf{w}_\eta(A) = s(f) + \mathbf{w}_\eta(A_2) < u$.

- Otherwise, we have on the one hand that $\mathbf{w}_\eta(A_1) = 0$, and on the other hand that $s(A_2) = t(A_1) < s(A_1) = h < u$ by Lemma 3.4.2.9. Thus, $\mathbf{w}_\eta(A) = \mathbf{w}_\eta(A_2) < u$.

□

Lemma 3.4.2.15. *Let (f_1, f_2, f_3) be a 3-fold local branching, $u \in \mathcal{A}_1^*$, and $A, B \in \mathcal{F}_3^{\mathbf{w}}$ two 3-cells such that there exists a 4-cell:*

$$C_{f_1, f_3, f_2} : \bar{f}_1 \bullet_1 \eta_{f_3} \bullet_1 f_2 \bullet_2 (C_{f_1, f_3} \bullet_1 C_{f_3, f_2}) \bullet_2 A \Rrightarrow C_{f_1, f_2} \bullet_2 B.$$

Then $\mathbf{w}_\eta(A), \mathbf{w}_\eta(B) < u$.

Proof. Using Lemma 3.4.2.9, we have $\mathbf{p}(t(C_{f_1, f_2})), \mathbf{p}(t(C_{f_2, f_3})), \mathbf{p}(t(C_{f_1, f_3})) < u$. So $\mathbf{p}(s(A)) = \mathbf{p}(t(C_{f_1, f_2}) + \mathbf{p}(t(C_{f_2, f_3})) < u$ et $\mathbf{p}(s(B)) = \mathbf{p}(t(C_{f_1, f_3})) < u$, and using 3.4.2.14, we get $\mathbf{w}_\eta(A), \mathbf{w}_\eta(B) < u$ □

3.4.3 Partial coherence of $\mathcal{F}^{\mathbf{w}(3)}$

Proposition 3.4.3.1. *For every 2-cell $h \in \mathcal{F}_2^{\mathbf{w}}$ with source and target \hat{u} a normal form for \mathcal{A}_2 , and for every 3-cells $A, B : h \Rrightarrow 1_{\hat{u}} \in \mathcal{F}_3^{\mathbf{w}}$, there exists a 4-cell $\alpha : A \Rrightarrow B \in \mathcal{F}_4^{\mathbf{w}(3)}$.*

Proof. We reason by induction on the couple $(\mathbf{w}_\eta(A) + \mathbf{w}_\eta(B), \mathbf{p}(h))$, using the lexicographic order. If $h = 1_{\hat{u}}$, then $A = B = 1_h$. Thus setting $\alpha = 1_A = 1_B$ shows that the property is verified.

Suppose now that h is not an identity. Using Lemma 3.4.2.11, there exists a cavity-factorisation $h = h_1 \bullet_1 \bar{f}_1 \bullet_1 f_2 \bullet_1 h_2$. By Lemma 3.4.2.13, there exist $A_1, A_2, B_1, B_2 \in \mathcal{F}_3^{\mathbf{w}}$, such that $A = (h_1 \bullet_1 A_1 \bullet_1 h_2) \bullet_2 A_2$ and $B = (h_1 \bullet_1 B_1 \bullet_1 h_2) \bullet_2 B_2$. Using this Lemma, we distinguish four cases depending on the shape of A_1 and A_2 .

If $A_1 = B_1 = C_{f_1, f_2}$. Then in particular we have:

$$s(A_2) = s(B_2) \quad \mathbf{w}_\eta(A) = \mathbf{w}_\eta(A_2) \quad \mathbf{w}_\eta(B) = \mathbf{w}_\eta(B_2) \quad t(A_1) < s(A_1),$$

where the last inequality is a consequence of Lemma 3.4.2.9. Hence, we get $\mathbf{p}(s(A_2)) = \mathbf{p}(h_1) + \mathbf{p}(t(A_1)) + \mathbf{p}(h_2) < \mathbf{p}(h_1) + \mathbf{p}(s(A_1)) + \mathbf{p}(h_2) = \mathbf{p}(h)$, and finally $(\mathbf{w}_\eta(A_2) + \mathbf{w}_\eta(B_2), \mathbf{p}(s(A_2))) < (\mathbf{w}_\eta(A) + \mathbf{w}_\eta(B), h)$. Using the induction hypothesis there exists $\alpha : A_2 \rightrightarrows B_2 \in \mathcal{F}_4^{\mathbf{w}(3)}$, and by composition we construct $A_1 \bullet_2 \alpha : A \rightarrow B$.

If $A_1 = \bar{f}_1 \bullet_1 \eta_{f_3} \bullet_1 f_2$ and $B_1 = C_{f_1, f_2}$. We are going to construct the following composite:

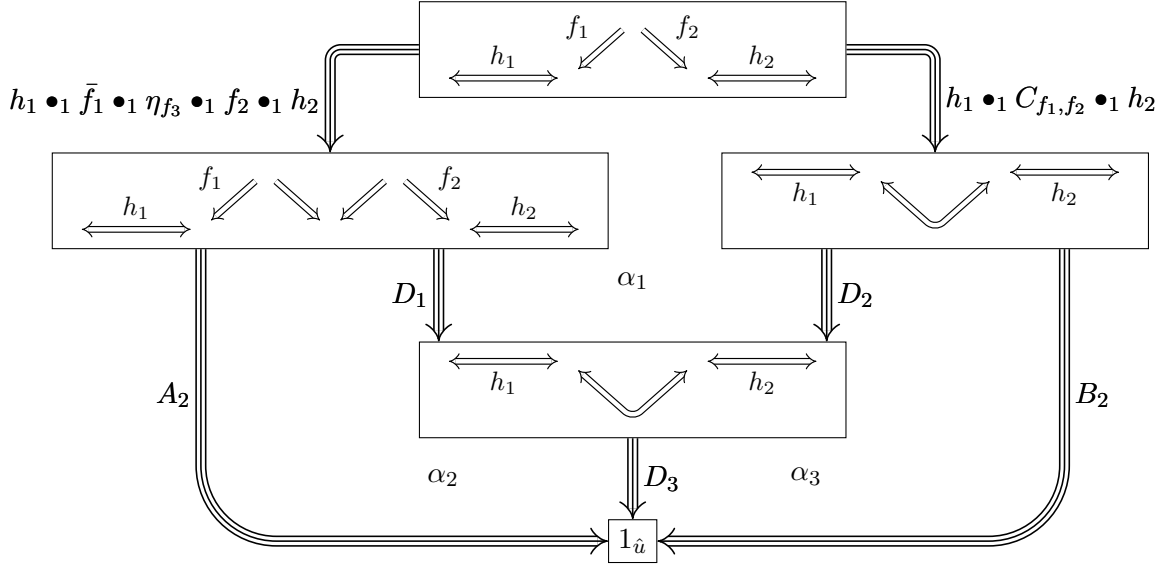

According to Lemma 3.4.1.3, there exists a 4-cell

$$C_{f_1, f_3, f_2} : \bar{f}_1 \bullet_1 \eta_{f_3} \bullet_1 f_2 \bullet_2 (C_{f_1, f_3} \bullet_1 C_{f_3, f_2}) \bullet_2 D'_1 \rightrightarrows C_{f_1, f_2} \bullet_2 D'_2,$$

with $D'_1, D'_2 \in \mathcal{F}_4^{\mathbf{w}(3)}$. Let us define $D_1 := h_1 \bullet_1 (C_{f_1, f_3} \bullet_1 C_{f_3, f_2}) \bullet_2 D'_1 \bullet_1 h_2$, $D_2 := h_1 \bullet_1 D'_2 \bullet_1 h_2$, and $\alpha_1 := h_1 \bullet_1 C_{f_1, f_3, f_2} \bullet_1 h_2$. The existence of D_3 is guaranteed by Lemma 3.4.2.12, which also proves that we can choose D_3 such that $\mathbf{w}_\eta(D_3) = 0$.

In order to construct the 4-cells α_1 and α_2 , let us show that we can apply the induction hypothesis to the couples $(A_2, D_1 \bullet_2 D_3)$ and $(D_2 \bullet_2 D_3, B_2)$. Let v be the common source of f_1 and f_2 .

- Using Lemma 3.4.2.15, $\mathbf{w}_\eta(D_1 \bullet_2 D_3) = \mathbf{w}_\eta(D_1) = \mathbf{w}_\eta(D'_1) < v$, and so:

$$\mathbf{w}_\eta(A_2) + \mathbf{w}_\eta(D_1 \bullet_2 D_3) < \mathbf{w}_\eta(A_2) + \mathbf{w}(\eta_3) = \mathbf{w}_\eta(A) \leq \mathbf{w}_\eta(A) + \mathbf{w}_\eta(B).$$

- As previously $\mathbf{w}_\eta(D_2 \bullet_2 D_3) = \mathbf{w}_\eta(D_2) = \mathbf{w}_\eta(D'_2) < v$, and so:

$$\mathbf{w}_\eta(B_2) + \mathbf{w}_\eta(D_2 \bullet_2 D_3) < \mathbf{w}_\eta(B_2) + \mathbf{w}(\eta_3) \leq \mathbf{w}_\eta(B) + \mathbf{w}_\eta(A).$$

If $A_1 = C_{f_1, f_2}$ and $B_1 = \bar{f}_1 \bullet_1 \eta_{f_3} \bullet_1 f_2$. This case is similar to the previous one, only using C_{f_1, f_3, f_2}^{-1} rather than C_{f_1, f_3, f_2} .

If $A_1 = \bar{f}_1 \bullet_1 \eta_{f_3} \bullet_1 f_2$ and $B_1 = \bar{f}_1 \bullet_1 \eta_{f_4} \bullet_1 f_2$. We are going to construct the following composite:

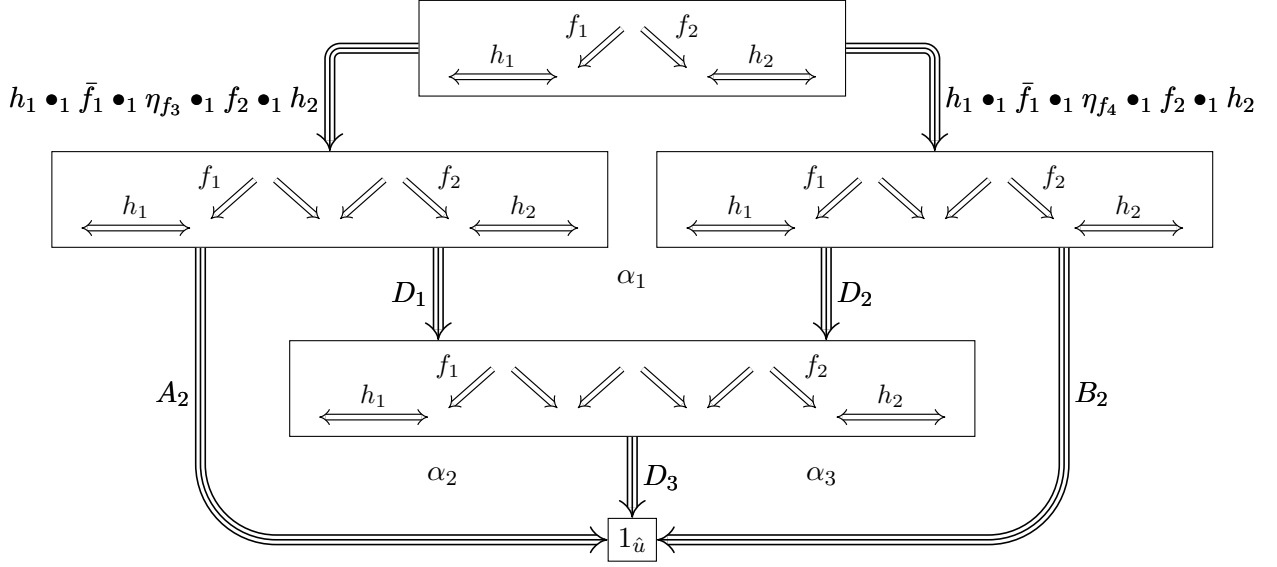

Let us set

$$D_1 := h_1 \bullet_1 \bar{f}_1 \bullet_1 f_3 \bullet_1 \bar{f}_3 \bullet_1 \eta_{f_4} \bullet_1 f_2 \bullet_1 h_2$$

$$D_2 := h_1 \bullet_1 \bar{f}_1 \bullet_1 \eta_{f_3} \bullet_1 f_4 \bullet_1 \bar{f}_4 \bullet_1 f_2 \bullet_1 h_2.$$

We then have

$$(h_1 \bullet_1 A_1 \bullet_1 h_2) \bullet_2 D_1 = h_1 \bullet_1 \bar{f}_1 \bullet_1 \eta_{f_3} \bullet_1 \eta_{f_4} \bullet_1 f_2 \bullet_1 h_2 = (h_1 \bullet_1 B_1 \bullet_1 h_2) \bullet_2 D_2.$$

Hence, we define α_1 as an identity. Let now D_3 be as in Lemma 3.4.2.12, with $\mathbf{w}_\eta(D_3) = 0$, and v be the common source of f_1, f_2, f_3 and f_4 . We then have the inequalities:

$$\mathbf{w}_\eta(A_2) + \mathbf{w}_\eta(D_1) + \mathbf{w}_\eta(D_3) = \mathbf{w}_\eta(A_2) + v < \mathbf{w}_\eta(A_2) + \mathbf{w}_\eta(B_2) + 2v = \mathbf{w}_\eta(A) + \mathbf{w}_\eta(B),$$

$$\mathbf{w}_\eta(B_2) + \mathbf{w}_\eta(D_2) + \mathbf{w}_\eta(D_3) = \mathbf{w}_\eta(B_2) + v < \mathbf{w}_\eta(B_2) + \mathbf{w}_\eta(A_2) + 2v = \mathbf{w}_\eta(A) + \mathbf{w}_\eta(B).$$

Hence we can apply the induction hypothesis to the couples $(A_2, D_1 \bullet_2 D_3)$ and $(D_2 \bullet_2 D_3, B_2)$, which provides α_2 and α_3 . \square

Proposition 3.4.3.2. *The white $(4, 3)$ -category $\mathcal{F}^{\mathbf{w}(3)}$ is $S_{\mathcal{E}}$ -coherent.*

Proof. Let $A, B : f \rightrightarrows h \in \mathcal{F}_3^{\mathbf{w}}$ whose 1-target is a normal form \hat{u} , with $f, g \in \mathcal{B}_2^{\mathbf{w}}$.

The 3-cells $(\bar{h} \bullet_1 A) \bullet_2 \epsilon_h$ and $(\bar{h} \bullet_1 B) \bullet_2 \epsilon_h$ are parallel, and their target is $1_{\hat{u}}$. In particular, they verify the hypothesis of Proposition 3.4.3.1. So there exists $\alpha : (\bar{h} \bullet_1 A) \bullet_2 \epsilon_h \rightrightarrows (\bar{h} \bullet_1 B) \bullet_2 \epsilon_h$. Then the following composite is the required cell from A to B :

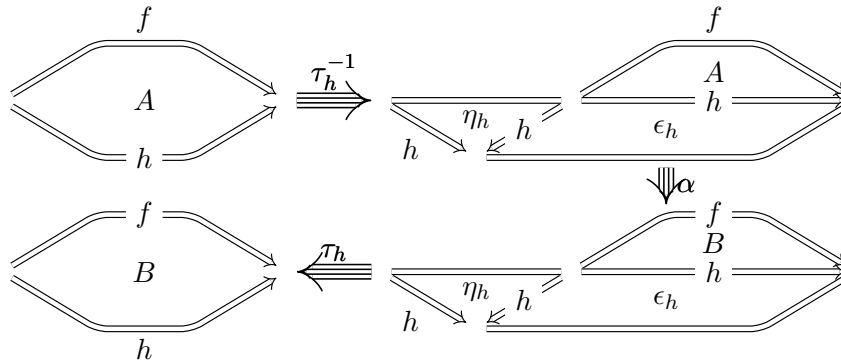



We can now complete the proof of Theorem 3.1.3.5. Indeed, we showed that $\mathcal{F}^{\mathbf{w}(3)}$ is $S_{\mathcal{E}}$ -coherent. Using Proposition 3.2.2.14, that means that $\mathcal{E}^{\mathbf{w}(3)}$ is $S_{\mathcal{E}}$ -coherent, and finally using Lemma 3.2.2.8 that $\mathcal{A}^{*(2)}$ is $S_{\mathcal{A}}$ -coherent, that is that for every 3-cells $A, B \in \mathcal{A}_3^{*(2)}$, whose 1-target is a normal form, there exists a 4-cell $\alpha : A \Rrightarrow B \in \mathcal{A}_4^{*(2)}$.

Chapter 4

Cubical (ω, p) -categories

Organisation

The goal of this chapter is to study the notion of (ω, p) -cubical category, in preparation for the next chapter. In Section 4.1, we recall a number of results on cubical ω -categories. In particular, we recall the definition of the two functors forming the equivalence between globular and cubical ω -categories.

In Section 4.2 we study the various forms of invertibility that exist in cubical ω -categories. In particular we define the notion of R_i -invertibility in Section 4.2.1, that of plain invertibility in Section 4.2.2 and finally the notion of T_i -invertibility in Section 4.2.3.

In Section 4.3, we finally define cubical (ω, p) -categories. In Section 4.3.1 we use the results on invertibility that we collected throughout Section 4.2, we prove the equivalence with the globular notion and characterize the notions of cubical $(\omega, 0)$ and $(\omega, 1)$ -categories. In Section 4.3.2 we introduce the notion of (ω, p) -ADCs and study its relationship with both globular and cubical (ω, p) -categories.

Lastly in Section 4.4, we apply the notions of invertibility as studied beforehand, to show firstly that cubical $(\omega, 1)$ -categories carry a natural structure of symmetric cubical categories in Section 4.4.1. Then in Section 4.4.2 we define and study the notion of pseudo transors between cubical ω -categories.

4.1 Cubical categories

In this section we recall the notion of ω -cubical categories (with connections) and the following functors

$$\begin{array}{ccc}
 & \lambda & \\
 \omega\text{-Cat} & \xleftarrow{\quad} & \omega\text{-CubCat} \\
 & \cong & \\
 & \gamma &
 \end{array}$$

defined in [2] that form an equivalence between the category of cubical ω -categories and that of globular ω -categories.

While our description of the functor λ matches exactly the description given in [2], we rephrase slightly the definition of γ . Our construction consists in defining a *co-cubical ω -category* object in $\omega\text{-Cat}$ (that is a cubical ω -category object in $\omega\text{-Cat}^{\text{op}}$), in order to define γ as a nerve functor. The starting point of this construction consists in describing the *standard globular ω -category of the n -cube* (denoted $n\text{-}\blacksquare^{\mathbf{G}}$ in this thesis, and $M(I^n)$ in [2]). Here we use the closed monoidal structure on $\omega\text{-Cat}$ to construct these categories, but one could equivalently define them as in [2] using directed complexes [76], or using augmented directed complexes [77].

4.1.1 Cubical sets

Definition 4.1.1.1. We denote by $n\text{-Cat}$ the category of strict globular n -categories (with $n \in \mathbb{N} \cup \{\omega\}$). We implicitly consider all globular n -categories (with $n \in \mathbb{N}$) to be globular ω -categories whose only cells in dimension higher than n are identities. Let \mathcal{C} be a globular ω -category and $n \geq 0$. We denote by \mathcal{C}_n the set of n -cells of \mathcal{C} . For $f \in \mathcal{C}_n$, and $0 \leq k < n$, we denote by $s_k(f) \in \mathcal{C}_k$ (resp. $t_k(f)$) the k -dimensional source (resp. target) of f , and we simply write $s(f)$ (resp. $t(f)$) for $s_{n-1}(f)$ (resp. $t_{n-1}(f)$). For $f, g \in \mathcal{C}_n$ such that $t_k(f) = s_k(g)$ we write $f \bullet_k g$ their composite. For $f \in \mathcal{C}_n$ we write 1_f the identity of f . Finally, for $x, y \in \mathcal{C}_0$, we denote by $\mathcal{C}(x, y)$ the globular ω -category of arrows between them.

We say that an n -cell $f \in \mathcal{C}_n$ is *invertible* if it is invertible for the composition \bullet_{n-1} , that is if there exists an n -cell $g \in \mathcal{C}_n$ such that $f \bullet_{n-1} g = 1_{s(f)}$ and $g \bullet_{n-1} f = 1_{t(f)}$. For $p \geq 0$, a *globular (ω, p) -category* is a globular ω -category in which any n -cell is invertible, for $n > p$. In particular, a globular $(\omega, 0)$ -category is just a globular ω -groupoid.

Definition 4.1.1.2. For every $i \in \mathbb{N}$, we define two applications $(_)^i : \mathbb{N} \rightarrow \mathbb{N} \setminus \{i\}$ and $(_)_i : \mathbb{N} \setminus \{i\} \rightarrow \mathbb{N}$ as follows:

$$j^i := \begin{cases} j & j < i \\ j + 1 & j \geq i \end{cases} \quad j_i := \begin{cases} j & j < i \\ j - 1 & j > i \end{cases}$$

Finally, for i, j distinct integers, we define applications $(_)_{i,j}$, $(_)^{i,j}$ and $(_)_i^j$ respectively as follows:

$$\begin{cases} \mathbb{N} \setminus \{i, j\} & \rightarrow & \mathbb{N} & & \mathbb{N} & \rightarrow & \mathbb{N} \setminus \{i, j\} & & \mathbb{N} \setminus \{i_j\} & \rightarrow & \mathbb{N} \setminus \{j_i\} \\ k & \mapsto & (k_i)_{j_i} & & k & \mapsto & (k^{i_j})^j & & k & \mapsto & (k^j)_i \end{cases}$$

Lemma 4.1.1.3. *The following equalities hold, for every k and every $i \neq j$:*

$$\begin{cases} k^{i,j} = k^{j,i} \\ k_{i,j} = k_{j,i} & k \neq i, j \\ k_i^j = (k_{i_j})^{j_i} & k \neq i_j \end{cases}$$

Proof. Recall that there is at most one isomorphism between any two well-ordered sets. Here $(_)_{i,j}$ and $(_)^{j,i}$ are both isomorphism from \mathbb{N} to $\mathbb{N} \setminus \{i, j\}$, hence they are equal. The same reasoning proves the other two equalities. \square

The series of Definitions 4.1.1.4, 4.1.1.6 and 4.1.2.1 is exactly the same as in [2], except that we make use of the notations introduced in Definition 4.1.1.2.

Definition 4.1.1.4. A pre-cubical set is a series of sets C_n (for $n \geq 0$) together with applications (called *faces operations*) $\partial_i^\alpha : C_n \rightarrow C_{n-1}$, for $\alpha = \pm$ and $1 \leq i \leq n$, satisfying

$$\partial_{i_j}^\alpha \partial_j^\beta = \partial_{j_i}^\beta \partial_i^\alpha \quad (4.1.1)$$

A morphism of pre-cubical sets is a family of applications $F_n : C_n \rightarrow D_n$ commuting with the faces operations.

Example 4.1.1.5. Following work of Grandis and Mauri [36], pre-cubical sets can be seen as presheaves over the free PRO generated by cells $\circlearrowleft : 0 \rightarrow 1$ and $\circlearrowright : 0 \rightarrow 1$. Then the applications $\partial_i^- : C_n \rightarrow C_{n-1}$ and $\partial_i^+ : C_n \rightarrow C_{n-1}$ correspond respectively to the following cells, with $i - 1$ strings on the left and $n - i$ on the right:

$$|\cdots| \circlearrowleft |\cdots| \quad |\cdots| \circlearrowright |\cdots|$$

Equation (4.1.1) corresponds to equations of the following form, replacing the occurrences of \circlearrowright either by \circlearrowleft or \circlearrowright depending on α and β :

$$|\cdots| \circlearrowright |\cdots| \circlearrowleft |\cdots| = |\cdots| \circlearrowleft |\cdots| \circlearrowright |\cdots|$$

Note finally that reading an expression $\partial_i^\alpha \dots \partial_j^\beta$ from left to right corresponds to reading a string diagram in the PRO from top to bottom.

Definition 4.1.1.6. A cubical set (with connections) is given by:

- For all $n \in \mathbb{N}$, a set C_n .
- For all $n \in \mathbb{N}^*$, all $1 \leq i \leq n$ and all $\alpha \in \{+, -\}$, applications $\partial_i^\alpha : C_n \rightarrow C_{n-1}$.
- For all $n \in \mathbb{N}$ and all $1 \leq i \leq n+1$, applications $\epsilon_i : C_n \rightarrow C_{n+1}$.
- For all $n \in \mathbb{N}^*$, all $1 \leq i \leq n$ and all $\alpha \in \{+, -\}$, applications $\Gamma_i^\alpha : C_n \rightarrow C_{n+1}$.

This data must moreover verify the following axioms:

$$\partial_i^\alpha \epsilon_j = \begin{cases} \epsilon_{j_i} \partial_{i_j}^\alpha & i \neq j \\ \text{id}_{C_n} & i = j \end{cases} \quad (4.1.2) \quad \epsilon_i \epsilon_{j_i} = \epsilon_j \epsilon_{ij} \quad (4.1.4)$$

$$\partial_i^\alpha \Gamma_j^\beta = \begin{cases} \Gamma_{j_i}^\beta \partial_{i_j}^\alpha & i \neq j, j+1 \\ \text{id}_{C_n} & i = j, j+1 \text{ and } \alpha = \beta \\ \epsilon_j \partial_j^\alpha & i = j, j+1 \text{ and } \alpha = -\beta \end{cases} \quad (4.1.3)$$

$$\Gamma_{ij}^\alpha \Gamma_j^\beta = \begin{cases} \Gamma_{j_i}^\beta \Gamma_i^\alpha & i \neq j \\ \Gamma_i^\alpha \Gamma_i^\alpha & i = j \text{ and } \alpha = \beta \end{cases} \quad (4.1.5)$$

$$\Gamma_i^\alpha \epsilon_j = \begin{cases} \epsilon_{j_i} \Gamma_{i_j}^\alpha & i \neq j \\ \epsilon_i \epsilon_i & i = j \end{cases} \quad (4.1.6)$$

Example 4.1.1.7. Following once again [36], cubical sets with connections can be seen as presheaves over the following PRO, denoted by \mathbb{J} and called the *intermediate cubical site* in [36]:

- The generators are the cells :

$$\circlearrowleft : 0 \rightarrow 1 \quad \bullet : 0 \rightarrow 1 \quad \circlearrowright : 1 \rightarrow 0 \quad \nabla : 2 \rightarrow 1 \quad \blacktriangledown : 2 \rightarrow 1$$

- They satisfy the following relations :

$$\begin{array}{l} \circlearrowleft = \\ \circlearrowleft = | = \circlearrowright \\ \bullet = \bullet = \bullet \\ \nabla = \nabla \\ \nabla = \bullet \bullet \\ \bullet = \bullet \bullet \end{array} \quad \begin{array}{l} \bullet = \\ \bullet = | = \bullet \\ \circlearrowleft = \bullet = \circlearrowright \\ \blacktriangledown = \blacktriangledown \\ \blacktriangledown = \bullet \bullet \end{array}$$

Then the applications $\Gamma_i^- : C_n \rightarrow C_{n+1}$, $\Gamma_i^+ : C_n \rightarrow C_{n+1}$ and ϵ_i correspond respectively to composites of the form $|\cdots| \nabla |\cdots|$, $|\cdots| \blacktriangledown |\cdots|$ and $|\cdots| \bullet |\cdots|$, with the appropriate number of strings on each side.

4.1.2 Cubical ω -categories

Definition 4.1.2.1. A cubical ω -category is given by a cubical set \mathbf{C} , equipped with, for all $n \in \mathbb{N}^*$ and all $1 \leq i \leq n$, a partial application \star_i from $\mathbf{C}_n \times \mathbf{C}_n$ to \mathbf{C}_n defined exactly for any cells A, B such that $\partial_i^+ A = \partial_i^- B$. This data must moreover satisfy the following axioms:

$$(A \star_i B) \star_j (C \star_i D) = (A \star_j C) \star_i (B \star_j D) \quad (4.1.7)$$

$$A \star_i \epsilon_i \partial_i^+ A = \epsilon_i \partial_i^- A \star_i A = A \quad (4.1.10)$$

$$A \star_i (B \star_i C) = (A \star_i B) \star_i C \quad (4.1.8)$$

$$\Gamma_i^+ A \star_i \Gamma_i^- A = \epsilon_{i+1} A \quad (4.1.11)$$

$$\epsilon_i (A \star_j B) = \epsilon_i^\alpha A \star_{j^i} \epsilon_i^\alpha B \quad (4.1.9)$$

$$\Gamma_i^+ A \star_{i+1} \Gamma_i^- A = \epsilon_i A \quad (4.1.12)$$

$$\partial_i^\alpha (A \star_j B) = \begin{cases} \partial_i^\alpha A \star_{j^i} \partial_i^\alpha B & i \neq j \\ \partial_i^- A & i = j \text{ and } \alpha = - \\ \partial_i^+ B & i = j \text{ and } \alpha = + \end{cases} \quad (4.1.13)$$

$$\Gamma_i^\alpha (A \star_j B) = \begin{cases} \Gamma_i^\alpha A \star_{j^i} \Gamma_i^\alpha B & i \neq j \\ \begin{array}{|c|c|} \hline \Gamma_i^- A & \epsilon_{i+1} B \\ \hline \epsilon_i B & \Gamma_i^- B \\ \hline \end{array} & \begin{array}{l} \xrightarrow{i} \\ \downarrow \\ i+1 \end{array} \quad i = j \text{ and } \alpha = - \\ \begin{array}{|c|c|} \hline \Gamma_i^+ A & \epsilon_i A \\ \hline \epsilon_{i+1} A & \Gamma_i^+ B \\ \hline \end{array} & \begin{array}{l} \xrightarrow{i} \\ \downarrow \\ i+1 \end{array} \quad i = j \text{ and } \alpha = + \end{cases} \quad (4.1.14)$$

where in the last relation we denote by $\begin{array}{|c|c|} \hline A & B \\ \hline C & D \\ \hline \end{array} \begin{array}{l} \xrightarrow{i} \\ \downarrow \\ j \end{array}$ the composite $(A \star_i B) \star_j (C \star_i D)$

(which is made possible by relation (4.1.7)). We denote by $\omega\text{-CubCat}$ the category of cubical ω -categories.

Definition 4.1.2.2. Let \mathbf{C} be a cubical ω -category. For any $n > 0$, we define operations $\psi_i, \Psi_r, \Phi_m : \mathbf{C}_n \rightarrow \mathbf{C}_n$, with $1 \leq i \leq n-1$, $1 \leq r \leq n$ and $0 \leq m \leq n$ as follows:

$$\begin{aligned} \psi_i A &= \Gamma_i^+ \partial_{i+1}^- A \star_{i+1} A \star_{i+1} \Gamma_i^- \partial_{i+1}^+ A \\ \Psi_r A &= \psi_{r-1} \cdots \psi_1 A \\ \Phi_m A &= \Psi_1 \cdots \Psi_m A \end{aligned}$$

Definition 4.1.2.3. Let \mathbf{C} be a cubical ω -category, and $A \in \mathbf{C}_n$. We say that A is a *thin* cell if $\psi_1 \cdots \psi_{n-1} A \in \mathbf{Im} \epsilon_1$.

Definition 4.1.2.4. Let $n \in \mathbb{N}$. There is a truncation functor $\text{tr}_n : (n+1)\text{-CubCat} \rightarrow n\text{-CubCat}$. This functor admits both a left and a right adjoint (see [43] for an explicit description of both functors).

$$\begin{array}{ccc} & \square & \\ \curvearrowleft & & \curvearrowright \\ & \perp & \\ (n+1)\text{-CubCat} & \xrightarrow{\text{tr}_n} & n\text{-CubCat} \\ & \perp & \\ & \square & \end{array}$$

For $\mathbf{C} \in n\text{-CubCat}$, the $(n+1)$ -category $\square\mathbf{C}$ coincides with \mathbf{C} up to dimension n , and the rest of the structure is defined as follows:

- The set of $(n + 1)$ -cells of $\square\mathbf{C}$ is the set of all families $(A_i^\alpha) \in \mathbf{C}_n$ (with $1 \leq i \leq n + 1$ and $\alpha = \pm$) such that:

$$\partial_{i_j}^\alpha A_j^\beta = \partial_{j_i}^\beta A_i^\alpha.$$

- For $A \in (\square\mathbf{C})_{n+1}$, $\partial_i^\alpha A = A_i^\alpha$.
- For $A \in \mathbf{C}_n$, the families $\epsilon_i A \in (\square\mathbf{C})_{n+1}$ and $\Gamma_i^\alpha A \in (\square\mathbf{C})_{n+1}$ are defined by:

$$(\epsilon_i A)_j^\beta = \begin{cases} A & j = i \\ \epsilon_{i_j} \partial_{j_i}^\beta A & j \neq i \end{cases} \quad (\Gamma_i^\alpha)_j^\beta = \begin{cases} A & j = i, i + 1 \text{ and } \beta = \alpha \\ \epsilon_i \partial_i^\beta A & j = i, i + 1 \text{ and } \beta = -\alpha \\ \Gamma_{i_j}^\alpha \partial_{j_i} A & j \neq i, i + 1 \end{cases}$$

- For $A, B \in (\square\mathbf{C})_{n+1}$ such that $A_i^+ = B_i^-$, the family $A \star_i B \in (\square\mathbf{C})_{n+1}$ is defined by:

$$(A \star_i B)_j^\alpha = \begin{cases} A_i^- & j = i \text{ and } \alpha = - \\ B_i^+ & j = i \text{ and } \alpha = + \\ A_j^\alpha \star_{i_j} B_j^\alpha & j \neq i \end{cases}$$

Let \mathbf{C} be a cubical $(n + 1)$ -category. The unit of the adjunction $\text{tr} \dashv \square$ induces a morphism of cubical $(n + 1)$ -categories $\partial : \mathbf{C} \rightarrow \square \text{tr} \mathbf{C}$. This functor associates, to any $A \in \mathbf{C}_{n+1}$ the family $\partial A := (\partial_i^\alpha A)$. We call ∂A the *shell* of A .

More generally, if \mathbf{C} is a cubical ω -category, we denote by $\square_n \mathbf{C}$ the $(n + 1)$ -category $\square \text{tr}_n \mathbf{C}$, and for any $A \in \mathbf{C}_{n+1}$, by ∂A the cell $\partial \text{tr}_{n+1} A \in \square_n \mathbf{C}$.

Theorem 4.1.2.5 (Proposition 2.1 and Theorem 2.8 from [43]). *Let \mathbf{C} be a cubical category. Thin cells of \mathbf{C} are exactly the composites of cells of the form $\epsilon_i f$ and $\Gamma_i^\alpha f$. Moreover, if two thin cells have the same shell, then they are equal.*

Notation 4.1.2.6. As a consequence, when writing thin cells in 2-dimensional compositions (as in Equation (4.1.14) for example), we make use of the notation already used in [2] and [43]: a thin cell A is replaced by a string diagram linking the non-thin faces of A . For example $\Gamma_i^+ A$ and $\Gamma_i^- A$ will respectively be represented by the symbols $\boxed{\ulcorner}$ and $\boxed{\llcorner}$, and the cells $\epsilon_i A$ by the symbol $\boxed{\dashv}$ or $\boxed{\lrcorner}$. Following this convention, Equations (4.1.11) and (4.1.12) can be represented by the following string diagrams:

$$\boxed{\ulcorner} \boxed{\llcorner} = \boxed{\lrcorner} \quad \boxed{\ulcorner} \boxed{\llcorner} = \boxed{\dashv} \quad \begin{array}{c} \downarrow \\ i+1 \end{array} \begin{array}{c} \rightarrow \\ i \end{array}$$

And the last two cases of Equation (4.1.14) become respectively:

$$\boxed{\llcorner} = \begin{array}{|c|c|} \hline \llcorner & \lrcorner \\ \hline \dashv & \ulcorner \\ \hline \end{array} \quad \boxed{\ulcorner} = \begin{array}{|c|c|} \hline \ulcorner & \dashv \\ \hline \lrcorner & \ulcorner \\ \hline \end{array} \quad \begin{array}{c} \downarrow \\ i+1 \end{array} \begin{array}{c} \rightarrow \\ i \end{array}$$

Finally, for any $A \in \mathbf{C}_n$, $\psi_i A$ is the following composite:

$$\psi_i A = \boxed{\ulcorner} \boxed{A} \boxed{\llcorner} \quad \begin{array}{c} \downarrow \\ i \end{array} \begin{array}{c} \rightarrow \\ i+1 \end{array}$$

4.1.3 Equivalence between cubical and globular ω -categories

The functor $\gamma : \omega\text{-CubCat} \rightarrow \omega\text{-Cat}$ was described in [2] as follows.

Proposition 4.1.3.1. *Let \mathbf{C} be a cubical category. The following assignment defines a globular ω -category $\gamma\mathbf{C}$:*

- The n -cells of $\gamma\mathbf{C}$ are the elements of $\Phi_n(\mathbf{C}_n)$,
- For all $A \in \gamma\mathbf{C}_n$, $1_A := \epsilon_1 A$,
- For all $A \in \gamma\mathbf{C}_n$, $s(A) := \partial_1^- A$,
- For all $A \in \gamma\mathbf{C}_n$, $t(A) := \partial_1^+ A$,
- For all $A, B \in \gamma\mathbf{C}_n$ and $0 \leq k < n$, $A \bullet_k B := A \star_{n-k} B$.

To define the functor $\lambda : \omega\text{-Cat} \rightarrow \omega\text{-CubCat}$, we start by constructing a co-cubical ω -category object in $\omega\text{-Cat}$. This is a reformulation of [2].

Definition 4.1.3.2. Let \mathbb{I} be the category with two 0-cells $(-)$ and $(+)$ and one non-identity 1-cell (θ) :

$$(\theta) : (-) \rightarrow (+)$$

We denote by $n\text{-}\blacksquare^{\mathbf{G}}$, and call the n -cube category the globular ω -category $\mathbb{I}^{\otimes n}$, where \otimes is the Crans-Gray tensor product, which equips $\omega\text{-Cat}$ with a closed monoidal structure.

Example 4.1.3.3. For example $2\text{-}\blacksquare^{\mathbf{G}}$ is the free 2-category with four 0-cells, four generating 1-cells and one generating 2-cell, with source and targets given by the following diagram:

$$\begin{array}{ccc} (-) & \xrightarrow{(\theta-)} & (+) \\ (-\theta) \downarrow & \swarrow A & \downarrow (+\theta) \\ (-) & \xrightarrow{(\theta+)} & (+) \end{array}$$

Definition 4.1.3.4. For $\alpha = \pm$, we denote by $\check{\partial}^\alpha : \top \rightarrow \mathbb{I}$ the functor sending the (unique) 0-dimensional cell of \top to (α) , where \top denotes the terminal category.

For any $n \geq 0$, any $1 \leq i \leq n$ and any $\alpha = \pm$, we denote by $\check{\partial}_i^\alpha : n\text{-}\blacksquare^{\mathbf{G}} \rightarrow (n+1)\text{-}\blacksquare^{\mathbf{G}}$ the functor $\mathbb{I}^{i-1} \otimes \check{\partial}^\alpha \otimes \mathbb{I}^{n-i}$.

Definition 4.1.3.5. We denote by $\check{\epsilon} : 1\text{-}\blacksquare^{\mathbf{G}} \rightarrow 0\text{-}\blacksquare^{\mathbf{G}}$ the (unique) functor from \mathbb{I} to \top .

For any $n > 0$ and any $1 \leq i \leq n$, we denote by $\check{\epsilon}_i : (n-1)\text{-}\blacksquare^{\mathbf{G}} \rightarrow n\text{-}\blacksquare^{\mathbf{G}}$ the functor $\mathbb{I}^{\otimes(i-1)} \otimes \check{\epsilon} \otimes \mathbb{I}^{\otimes(n-i)}$.

Definition 4.1.3.6. For $\alpha = \pm$, let $\check{\Gamma}^\alpha : 2\text{-}\blacksquare^{\mathbf{G}} \rightarrow 1\text{-}\blacksquare^{\mathbf{G}}$ be the functor defined as follows, where $\beta = -\alpha$:

$$\left\{ \begin{array}{l} \check{\Gamma}^\alpha(\alpha\alpha) = (\alpha) \\ \check{\Gamma}^\alpha(\alpha\beta) = (\beta) \\ \check{\Gamma}^\alpha(\beta\alpha) = (\beta) \\ \check{\Gamma}^\alpha(\beta\beta) = (\beta) \end{array} \right. \quad \left\{ \begin{array}{l} \check{\Gamma}^\alpha(\theta\alpha) = (\theta) \\ \check{\Gamma}^\alpha(\theta\beta) = 1_{(\beta)} \\ \check{\Gamma}^\alpha(\alpha\theta) = (\theta) \\ \check{\Gamma}^\alpha(\beta\theta) = 1_{(\beta)} \end{array} \right. \quad \check{\Gamma}^\alpha(\theta\theta) = 1_{(\theta)}$$

For any $n > 0$ any $1 \leq i \leq n$ and any $\alpha = \pm$, we denote by $\check{\Gamma}_i^\alpha : n\text{-}\blacksquare^{\mathbf{G}} \rightarrow (n+1)\text{-}\blacksquare^{\mathbf{G}}$ the functor $\mathbb{I}^{\otimes(i-1)} \otimes \check{\Gamma}^\alpha \otimes \mathbb{I}^{\otimes(n-i)}$.

Definition 4.1.3.7. We denote by $\mathbf{Rect}^{\mathbf{G}}$ the following pushout in $\omega\text{-Cat}$:

$$\begin{array}{ccc} 0\text{-}\blacksquare^{\mathbf{G}} & \xrightarrow{\check{\partial}^+} & 1\text{-}\blacksquare^{\mathbf{G}} \\ \check{\partial}^- \downarrow & \ulcorner & \downarrow \\ 1\text{-}\blacksquare^{\mathbf{G}} & \longrightarrow & \mathbf{Rect}^{\mathbf{G}} \end{array} \quad (4.1.15)$$

Explicitly, the 0-cells of $\mathbf{Rect}^{\mathbf{G}}$ are elements (α_j) , where $\alpha = \pm$ and $i = 1, 2$, with the identification $(+1) = (-2)$. The 1-cells of $\mathbf{Rect}_0^{\mathbf{ADC}}$ are freely generated by $(\theta_i) : (-i) \rightarrow (+i)$, for $i = 1, 2$.

For every $n > 0$ and every $1 \leq i \leq n$, let $(n, i)\text{-}\mathbf{Rect}^{\mathbf{G}}$ be the cubical ω -category:

$$(n, i)\text{-}\mathbf{Rect}^{\mathbf{G}} := \mathbb{I}^{(i-1)} \otimes \mathbf{Rect}^{\mathbf{G}} \otimes \mathbb{I}^{(n-i)}$$

Remark 4.1.3.8. Since the monoidal structure on $\omega\text{-Cat}$ is biclosed [2], $(n, i)\text{-}\mathbf{Rect}^{\mathbf{G}}$ is the colimit of the following diagram:

$$\begin{array}{ccc} (n-1)\text{-}\blacksquare^{\mathbf{G}} & \xrightarrow{\check{\partial}_i^+} & n\text{-}\blacksquare^{\mathbf{G}} \\ \check{\partial}_i^- \downarrow & \ulcorner & \downarrow \\ n\text{-}\blacksquare^{\mathbf{G}} & \longrightarrow & (n, i)\text{-}\mathbf{Rect}^{\mathbf{G}} \end{array} \quad (4.1.16)$$

Definition 4.1.3.9. We denote by $\check{\star} : 1\text{-}\blacksquare^{\mathbf{G}} \rightarrow \mathbf{Rect}^{\mathbf{G}}$ the following functor:

$$\begin{cases} \check{\star}(-) = (-1) \\ \check{\star}(+) = (+2) \end{cases} \quad \check{\star}(\theta) = (\theta_1) \bullet_0 (\theta_2)$$

For any $n > 0$ and any $1 \leq i \leq n$, we denote by $\check{\star}_i : n\text{-}\blacksquare^{\mathbf{G}} \rightarrow (n, i)\text{-}\mathbf{Rect}^{\mathbf{G}}$ the functor $\mathbb{I}^{\otimes(i-1)} \otimes \check{\star} \otimes \mathbb{I}^{\otimes(n-i)}$.

This result is a reformulation of Section 2 of [2]:

Proposition 4.1.3.10. *The objects $n\text{-}\blacksquare^{\mathbf{G}}$ equipped with the applications $\check{\partial}_i^\alpha$, $\check{\epsilon}_i$, $\check{\Gamma}_i^\alpha$ and $\check{\star}_i$ form a co-cubical ω -category object in the category $\omega\text{-Cat}$.*

Consequently, for \mathcal{C} a globular ω -category, the family $(\lambda\mathcal{C})_n = \omega\text{-Cat}(n\text{-}\blacksquare^{\mathbf{G}}, \mathcal{C})$ comes equipped with a structure of cubical ω -category, that we denote by $\lambda\mathcal{C}$. This defines a functor $\lambda : \omega\text{-Cat} \rightarrow \omega\text{-CubCat}$.

Finally, the main result of [2] is the following:

Theorem 4.1.3.11. *The following functors form an equivalence of Categories:*

$$\begin{array}{ccc} & \lambda & \\ \omega\text{-Cat} & \xleftarrow{\quad} & \omega\text{-CubCat} \\ & \gamma & \end{array} \quad \cong$$

4.2 Invertible cells in cubical ω -categories

In this Section, we investigate three notions of invertibility in cubical ω -categories. We start by defining in Section 4.2.1, both the notion of R_i -invertibility, which is a direct cubical analogue of the usual notion of invertibility with respect to a binary composition, and the notion of (plain) invertibility, which is specific to cubical ω -categories. Then in Section 4.2.3, we define a notion of T_i -invertibility, a variant of the notion of R_i -invertibility using a kind of diagonal composition.

4.2.1 R_i -invertibility

We start by proving a number of useful Lemmas about the notion of R_i -invertibility. We then proceed to give the definition of (plain) invertibility in Definition 4.2.2.1. The rest of the Section is then used to prove a characterisation of R_i -invertibility in terms of invertibility, which is achieved in Proposition 4.2.2.2.

Definition 4.2.1.1. Let \mathbf{C} be a cubical ω -category, and $1 \leq k \leq n$ be integers. We say that a cell $A \in \mathbf{C}_n$ is R_k -invertible if there exists $B \in \mathbf{C}_n$ such that $A \star_k B = \epsilon_k \partial_k^- A$ and $B \star_k A = \epsilon_k \partial_k^+ A$. We call B the R_k -inverse of A , and we write $R_k A$ for B .

In particular, we say that $A \in \mathbf{C}_n$ has an R_k -invertible shell if ∂A is R_k -invertible in $\square_n \mathbf{C}$.

Lemma 4.2.1.2. Let \mathbf{C} be a cubical n -category, and $A \in (\square \mathbf{C})_{n+1}$. Then A is R_i -invertible if and only if for all $j \neq i$, A_j^α is R_{i_j} -invertible, and:

$$\partial_i^\alpha R_k A = \begin{cases} \partial_k^{-\alpha} A & i = k \\ R_{k_i} \partial_i^\alpha A & i \neq k \end{cases}$$

In particular, for \mathbf{C} a cubical ω -category, a cell $A \in \mathbf{C}_n$ has an R_i -invertible shell if and only if $\partial_j^\alpha A$ is R_{i_j} -invertible for any $j \neq i$.

Proof. Let B be the R_k -inverse of A , and $i \neq k$. We have:

$$\begin{aligned} A_i^\alpha \star_{k_i} B_i^\alpha &= (A \star_k B)_i^\alpha = \partial_i^\alpha \epsilon_k A_k^- = \epsilon_{k_i} \partial_{i_k}^\alpha A_k^- = \epsilon_{k_i} \partial_{k_i k}^- A_i^\alpha = \epsilon_{k_i} \partial_{k_i}^- A_i^\alpha, \\ B_i^\alpha \star_{k_i} A_i^\alpha &= (B \star_k A)_i^\alpha = \partial_i^\alpha \epsilon_k A_k^+ = \epsilon_{k_i} \partial_{i_k}^\alpha A_k^+ = \epsilon_{k_i} \partial_{k_i k}^+ A_i^\alpha = \epsilon_{k_i} \partial_{k_i}^+ A_i^\alpha. \end{aligned}$$

Thus B_i^α is the k_i -inverse of A_i^α , that is $\partial_i^\alpha R_k A = R_{k_i} \partial_i^\alpha A$.

Moreover, for the composite $A \star_k R_k A$ (resp. $R_k A \star_k A$) to make sense we necessarily have $\partial_k^- R_k A = \partial_k^+ A$ (resp. $\partial_k^+ R_k A = \partial_k^- A$). \square

The following Lemma will be useful in order to compute the R_i -inverses of thin cells.

Lemma 4.2.1.3. Let \mathbf{C} be a cubical ω -category, and let A be a thin cell in \mathbf{C}_n . We fix an integer $i \leq n$. If there exists a thin cell B in \mathbf{C}_n such that $\partial_i^\alpha B = \partial_i^{-\alpha} A$, and for all $j \neq i$, $\partial_j^\alpha B = R_{i_j} \partial_j^\alpha A$, then A is R_i -invertible, and $B = R_i A$.

Proof. Since $\partial_i^- B = \partial_i^+ A$, A and B are i -composable. Let us look at the cell $A \star_i B$. It is a thin cell, and it has the following shell:

$$\partial_j^\alpha (A \star_i B) = \begin{cases} \partial_i^- A = \partial_i^- \epsilon_i \partial_i^- A & j = i \text{ and } \alpha = - \\ \partial_i^+ B = \partial_i^- A = \partial_i^- \epsilon_i \partial_i^- A & j = i \text{ and } \alpha = + \\ \partial_j^\alpha A \star_{i_j} \partial_j^\alpha B = \partial_j^\alpha A \star_{i_j} R_{i_j} \partial_j^\alpha A = \epsilon_{i_j} \partial_{i_j}^- \partial_j^\alpha A = \partial_j^\alpha \epsilon_i \partial_i^- A & j \neq i \end{cases}$$

Therefore, $A \star_i B$ and $\epsilon_i \partial_i^- A$ are two thin cells that have the same shell. By Theorem 4.1.2.5, they are equal. The same computation with $B \star_i A$ leads to the equality $B \star_i A = \epsilon_i \partial_i^+ A$. Finally, A is R_i -invertible, and $R_i A = B$. \square

Lemma 4.2.1.4. *Let \mathbf{C} be a cubical ω -category, and fix $A, B \in \mathbf{C}_n$ and $1 \leq k \leq n$.*

- *For any $i \leq n$, if A, B are R_k -invertible and i -composable, then $A \star_i B$ is R_k -invertible, and:*

$$R_k(A \star_i B) = \begin{cases} R_k A \star_i R_k B & i \neq k \\ R_k B \star_k R_k A & i = k \end{cases} \quad (4.2.1)$$

- *For any $i \leq n + 1$, $\epsilon_i A$ is R_i -invertible and $R_i \epsilon_i A = \epsilon_i A$. Moreover, if A is R_k -invertible then $\epsilon_i A$ is also R_{k^i} invertible, with*

$$R_{k^i} \epsilon_i A = \epsilon_i R_k A \quad (4.2.2)$$

- *For any $i \neq k$ and $\alpha = \pm$, if A is R_k -invertible, then $\Gamma_i^\alpha A$ is R_{k^i} invertible, and $\Gamma_k^\alpha A$ is both R_k and R_{k+1} -invertible, and:*

$$R_{k^i} \Gamma_i^\alpha A = \Gamma_i^\alpha R_k A \quad (4.2.3)$$

$$R_k \Gamma_k^\alpha A = \begin{cases} \epsilon_{k+1} R_k A \star_{k+1} \Gamma_k^+ A & \alpha = - \\ \Gamma_k^- A \star_k \epsilon_{k+1} R_k A & \alpha = + \end{cases} \quad R_{k+1} \Gamma_k^\alpha A = \begin{cases} \epsilon_k R_k A \star_{k+1} \Gamma_k^+ A & \alpha = - \\ \Gamma_k^- A \star_{k+1} \epsilon_k R_k A & \alpha = + \end{cases} \quad (4.2.4)$$

Proof. Suppose A and B are k -invertible, and let $i \leq n$. If $i \neq k$, Then we have:

$$\begin{aligned} (R_k A \star_i R_k B) \star_k (A \star_i B) &= (R_k A \star_k A) \star_i (R_k B \star_k B) = \epsilon_k \partial_k^+ A \star_i \epsilon_k \partial_k^+ B = \epsilon_k \partial_k^+ (A \star_i B) \\ (A \star_i B) \star_k (R_k A \star_i R_k B) &= (A \star_k R_k A) \star_i (B \star_k R_k B) = \epsilon_k \partial_k^- A \star_i \epsilon_k \partial_k^- B = \epsilon_k \partial_k^- (A \star_i B). \end{aligned}$$

Thus $A \star_i B$ is R_k -invertible and $R_k(A \star_i B) = R_k A \star_i R_k B$. Suppose now that $i = k$. Then we have:

$$\begin{aligned} R_k B \star_k R_k A \star_k A \star_k B &= \epsilon_k \partial_k^+ B = \epsilon_k \partial_k^+ (A \star_k B) \\ A \star_k B \star_k R_k B \star_k R_k A &= \epsilon_k \partial_k^- A = \epsilon_k \partial_k^- (A \star_k B). \end{aligned}$$

So $A \star_k B$ is R_k -invertible, and $R_k(A \star_k B) = R_k B \star_k R_k A$.

Suppose $i \neq k$. Then we have:

$$\begin{aligned} \Gamma_i^\alpha A \star_{k^i} \Gamma_i^\alpha R_k A &= \Gamma_i^\alpha (A \star_k R_k A) = \Gamma_i^\alpha \epsilon_k \partial_k^- A = \epsilon_{k^i} \Gamma_{i_k}^\alpha \partial_k^- A = \epsilon_{k^i} \partial_{k^i}^- \Gamma_i^\alpha A \\ \Gamma_i^\alpha R_k A \star_{k^i} \Gamma_i^\alpha A &= \Gamma_i^\alpha (R_k A \star_k A) = \Gamma_i^\alpha \epsilon_k \partial_k^+ A = \epsilon_{k^i} \Gamma_{i_k}^\alpha \partial_k^+ A = \epsilon_{k^i} \partial_{k^i}^+ \Gamma_i^\alpha A \end{aligned}$$

Thus $\Gamma_i^\alpha A$ is R_{k^i} -invertible, and $R_{k^i} \Gamma_i^\alpha A = \Gamma_i^\alpha R_k A$.

Suppose now $i = k$, and $\alpha = -$. In order to show that $R_k \Gamma_k^- A = \epsilon_{k+1} R_k A \star_{k+1} \Gamma_k^+ A$, we are going to use Lemma 4.2.1.3. Note first that both $\Gamma_k^- A$ and $\epsilon_{k+1} R_k A \star_{k+1} \Gamma_k^+ A$ are thin, so we only need to check the hypothesis about the shell of $\epsilon_{k+1} R_k A \star_{k+1} \Gamma_k^+ A$. Note that the hypotheses on directions k and $k + 1$ are always satisfied:

$$\partial_j^\alpha (\epsilon_{k+1} R_k A \star_{k+1} \Gamma_k^+ A) = \begin{cases} \epsilon_k \partial_k^- R_k A = \epsilon_k \partial_k^+ A = \partial_k^+ \Gamma_k^- A & j = k \text{ and } \alpha = - \\ \partial_k^+ \Gamma_k^+ A = A = \partial_k^- \Gamma_k^- A & j = k \text{ and } \alpha = + \\ R_k A \star_k \partial_{k+1}^- \Gamma_k^+ A = R_k A \star_k \epsilon_k \partial_k^- A = R_k A = R_k \partial_k^- \Gamma_k^- A & j = k + 1 \text{ and } \alpha = - \\ R_k A \star_k \partial_{k+1}^+ \Gamma_k^+ A = R_k A \star_k A = \epsilon_k \partial_k^+ A = R_k \partial_k^+ \Gamma_k^- A & j = k + 1 \text{ and } \alpha = + \end{cases}$$

As for the remaining directions, we reason by induction on n , the dimension of A . The case where $n = 1$ (and thus $k = 1$), there is no other direction to check and so $R_1 \Gamma_1^- = \epsilon_2 R_1 A \star_2 \Gamma_1^+$.

Suppose now $n > 1$, and let $j \leq n + 1$, with $j \neq k, k + 1$. Then we have the following equalities (where the fourth one uses the induction hypothesis):

$$\begin{aligned}
\partial_j^\alpha(\epsilon_{k+1}R_kA \star_k \Gamma_k^+ A) &= \partial_j^\alpha \epsilon_{k+1}R_kA \star_{k_j} \partial_j^\alpha \Gamma_k^+ A \\
&= \epsilon_{(k+1)_j} \partial_{j_{k+1}}^\alpha R_kA \star_{k_j} \Gamma_{k_j}^+ \partial_{j_k}^\alpha A \\
&= \epsilon_{k_j+1} R_{k_j} \partial_{j_k}^\alpha A \star_{k_j} \Gamma_{k_j}^+ \partial_{j_k}^\alpha A \\
&= R_{k_j} \Gamma_{k_j}^- \partial_{j_k}^\alpha A \\
&= R_{k_j} \partial_j^\alpha \Gamma_k^- A
\end{aligned}$$

Thus, by Lemma 4.2.1.3, $\Gamma_k^- A$ is R_k -invertible, and $R_k \Gamma_k^- A = \epsilon_{k+1} R_k A \star_{k+1} \Gamma_k^+ A$.

The proofs of the remaining three cases ($i = k$ with $\alpha = +$, and $i = k + 1$ with $\alpha = \pm$) are similar. \square

Remark 4.2.1.5. Note that Lemma 4.2.1.4 shows in particular that, if A is R_k -invertible, then $R_k \Gamma_i^\alpha A$, $R_k \Gamma_k^\alpha A$ and $R_{k+1} \Gamma_k^\alpha A$ are thin. In particular, applying the Notation defined in 4.1.2.6, we get the equations:

$$R_k \boxed{\ulcorner} = \boxed{\lrcorner} \quad R_{k+1} \boxed{\ulcorner} = \boxed{\llcorner} \quad R_k \boxed{\lrcorner} = \boxed{\llcorner} \quad R_{k+1} \boxed{\lrcorner} = \boxed{\lrcorner} \quad \begin{array}{c} \xrightarrow{k} \\ \downarrow \\ k+1 \end{array}$$

Remark 4.2.1.6. Let \mathbf{C} be a cubical n -category and $A \in (\square \mathbf{C})_{n+1}$. Recall from [43] that for all $i \neq 1$, $\partial_i^\alpha \psi_1 \dots \psi_n A \in \mathbf{Im} \epsilon_1$. Therefore, by Lemma 4.2.1.2 $\psi_1 \dots \psi_n A$ is R_1 -invertible. So finally, any cell in $\square \mathbf{C}$ is invertible.

Lemma 4.2.1.7. Let \mathbf{C} be a cubical ω -category, and $A \in \mathbf{C}_n$. Suppose A is R_j -invertible for some $j \leq n$. Then :

- The n -cell $\psi_i A$ is R_j -invertible for any $i \neq j - 1$.
- The n -cell $\psi_{j-1} A$ is R_{j-1} -invertible

Proof. Suppose first $j \neq i, i + 1$. Then we have $\psi_i A \star_j \psi_i R_j A = \psi_i(A \star_j R_j A) = \psi_i \epsilon_j \partial_j^- A = \epsilon_j \partial_j^- \psi_i A$, as well as $\psi_i R_j A \star_j \psi_i A = \psi_i(R_j A \star_j A) = \psi_i \epsilon_j \partial_j^+ A = \epsilon_j \partial_j^+ \psi_i A$. Hence, $\psi_i A$ is R_j -invertible, and $R_j \psi_i A = \psi_i R_j A$.

Suppose now $j = i$. Then $\psi_i A$ is a composite of R_i -invertible cells. As a consequence it is R_i -invertible.

Suppose now $j = i + 1$. Let B be the following composite:

$$\begin{array}{|c|c|c|c|c|} \hline \ulcorner & - & \lrcorner & | & | \\ \hline | & \ulcorner & R_j A & \lrcorner & | \\ \hline | & | & \llcorner & - & \lrcorner \\ \hline \end{array} \quad \begin{array}{c} \xrightarrow{j} \\ \downarrow \\ j-1 \end{array}$$

Let us show that B is the R_{j-1} -inverse of $\psi_{j-1} A$:

$$\begin{aligned}
\psi_{j-1}A \star_{j-1} B &= \begin{array}{|c|c|c|c|c|c|} \hline & & & \ulcorner & A & \lrcorner \\ \hline \ulcorner & - & \neg & | & | & \\ \hline | & \ulcorner & R_j A & \lrcorner & | & \\ \hline | & | & \llcorner & - & \lrcorner & \\ \hline \end{array} = \begin{array}{|c|c|c|c|c|c|} \hline \ulcorner & - & \neg & \ulcorner & A & \lrcorner \\ \hline | & \ulcorner & R_j A & \lrcorner & | & \\ \hline | & | & \llcorner & - & \lrcorner & \\ \hline \end{array} \begin{array}{l} \xrightarrow{j} \\ \downarrow \\ j-1 \end{array} \\
&= \begin{array}{|c|c|c|c|c|} \hline \ulcorner & - & \neg & | & | \\ \hline | & \ulcorner & R_j A & A & \lrcorner \\ \hline | & | & \llcorner & \lrcorner & \\ \hline \end{array} = \begin{array}{|c|c|c|c|c|} \hline \ulcorner & - & \neg & | & | \\ \hline | & & \llcorner & \lrcorner & | \\ \hline | & \ulcorner & - & - & \lrcorner \\ \hline \end{array} \begin{array}{l} \xrightarrow{j} \\ \downarrow \\ j-1 \end{array} \\
&= \begin{array}{|c|c|} \hline | & | \\ \hline \end{array} \begin{array}{l} \xrightarrow{j} \\ \downarrow \\ j-1 \end{array} = \epsilon_{j-1} \partial_{j-1}^- \psi_{j-1} A
\end{aligned}$$

A similar computation shows that $B \star_{j-1} \psi_{j-1} A = \epsilon_{j-1} \partial_{j-1}^+ \psi_{j-1} A$ and thus $\psi_{j-1} A$ is R_{j-1} -invertible. \square

Lemma 4.2.1.8. *Let \mathbf{C} be a cubical ω -category, and $A \in \mathbf{C}_n$ be an n -cell with an R_j -invertible shell for some $j \leq n$. Then:*

- *If $\psi_i A$ is R_j -invertible for some $i \neq j - 1$, then A is R_j -invertible. Moreover, if $R_j \psi_i A$ is thin then so is $R_j A$.*
- *If $\psi_{j-1} A$ is R_{j-1} -invertible, then A is R_j -invertible. Moreover, if $R_{j-1} \psi_{j-1} A$ is thin then so is $R_j A$.*

Proof. Suppose $\psi_i A$ is R_j -invertible, with $i \neq j$. Recall that the following composite is equal to A

$$\begin{array}{|c|c|} \hline \epsilon_{i+1} \partial_i^- A & \Gamma_i^+ \partial_{i+1}^+ A \\ \hline \psi_i A & \\ \hline \Gamma_i^- \partial_{i+1}^- A & \epsilon_{i+1} \partial_i^+ A \\ \hline \end{array}$$

Using the string notation for thin cells, this composite can be represented as follows:

$$\begin{array}{|c|c|} \hline | & \ulcorner \\ \hline \psi_i A & \\ \hline \lrcorner & | \\ \hline \end{array} \begin{array}{l} \xrightarrow{i+1} \\ \downarrow \\ i \end{array}$$

This notation is ambiguous, since it does not specify which factorisations of $\partial_i^\alpha \psi_i A$ are used. However, we use the convention that in any diagram of this form, the standard factorisations $\partial_i^- \psi_i A = \partial_i^- A \star_i \partial_{i+1}^+ A$ and $\partial_i^+ \psi_i A = \partial_{i+1}^- A \star_i \partial_i^+ A$ are used.

Since A has an R_j -invertible shell, by Lemma 4.2.1.4, every cell in this composite is R_j -invertible, and A is R_j -invertible. Moreover, if $R_j \psi_i A$ is thin, then the explicit formulas from Lemma 4.2.1.4 prove that $R_j A$ is thin.

Suppose now that $\psi_{j-1}A$ is R_{j-1} -invertible. We denote by B the following composite:

$$\begin{array}{|c|c|c|c|} \hline | & \ulcorner & - & - \\ \hline | & | & \urcorner & \lrcorner \\ \hline | & R_{j-1}\psi_{j-1}A & & | \\ \hline \llcorner & \lrcorner & | & | \\ \hline - & - & \lrcorner & | \\ \hline \end{array} \xrightarrow{j-1} j$$

We are going to show that B is the R_j -inverse of A . Notice that if $R_{j-1}\psi_{j-1}A$ is thin, then B is thin, using Lemma 4.2.1.4. Let us evaluate the composite $A \star_j B$:

$$\begin{array}{|c|c|c|c|c|} \hline | & | & \ulcorner & - & - \\ \hline | & | & | & \urcorner & \lrcorner \\ \hline | & | & R_{j-1}\psi_{j-1}A & & | \\ \hline | & \llcorner & \lrcorner & | & | \\ \hline A & - & - & \lrcorner & | \\ \hline \end{array} = \begin{array}{|c|c|c|c|} \hline & \ulcorner & - & - \\ \hline & | & \urcorner & \lrcorner \\ \hline & R_{j-1}\psi_{j-1}A & & | \\ \hline \urcorner & \lrcorner & | & | \\ \hline A & - & \lrcorner & | \\ \hline \end{array} = \begin{array}{|c|c|c|c|} \hline & \ulcorner & - & - \\ \hline & | & \urcorner & \lrcorner \\ \hline & R_{j-1}\psi_{j-1}A & & | \\ \hline \urcorner & A & \lrcorner & | \\ \hline \lrcorner & | & & | \\ \hline \end{array} \xrightarrow{j-1} j$$

$$\begin{array}{|c|c|c|} \hline \ulcorner & - & - \\ \hline | & \urcorner & \lrcorner \\ \hline R_{j-1}\psi_{j-1}A & & | \\ \hline \psi_{j-1}A & & | \\ \hline \lrcorner & | & | \\ \hline \end{array} = \begin{array}{|c|c|c|} \hline \ulcorner & - & - \\ \hline | & \urcorner & \lrcorner \\ \hline R_{j-1}\psi_{j-1}A & & | \\ \hline \psi_{j-1}A & & | \\ \hline \lrcorner & | & | \\ \hline \end{array} \xrightarrow{j-1} j$$

$$\begin{array}{|c|c|c|} \hline \ulcorner & - & - \\ \hline | & \urcorner & \lrcorner \\ \hline \lrcorner & | & | \\ \hline \end{array} \xrightarrow{j-1} j$$

$$= \epsilon_j \hat{\partial}_j^- A$$

The evaluation of $B \star_j A$ is similar. ◻

4.2.2 Plain invertibility

Definition 4.2.2.1. We say that a cell $A \in \mathbf{C}_n$ is *invertible* if $\psi_1 \dots \psi_{n-1}A$ is R_1 -invertible.

The rest of this Section is devoted to establishing the link between R_i -invertibility and (plain) invertibility. This is achieved in Proposition 4.2.2.2. In order to do this, we make use of the Lemmas 4.2.1.7 and 4.2.1.8, which relate the R_i -invertibility of a cell A with that of $\psi_j A$.

Proposition 4.2.2.2. *Let \mathbf{C} be a cubical ω -category, $A \in \mathbf{C}_n$ and $1 \leq j \leq n$. A cell $A \in \mathbf{C}_n$ is R_j -invertible if and only if A is invertible and has an R_j -invertible shell. Moreover, if A is thin, then so is its R_j -inverse.*

Proof. Suppose first that A is R_j -invertible. Then its shell is R_j -invertible, and for all $i \geq j$, $\psi_i \dots \psi_{n-1}A$ is R_j -invertible. Repeated applications of Lemma 4.2.3.4 show that $\psi_j \dots \psi_{n-1}A$ is

R_j -invertible. As a result (still by Lemma 4.2.3.4), $\psi_{j-1} \dots \psi_{n-1}A$ is R_{j-1} -invertible. Inductively we show that for any $i \leq j$, $\psi_i \dots \psi_{n-1}A$ is R_i -invertible. Finally, we get that $\psi_1 \dots \psi_{n-1}A$ is R_1 -invertible, in other words that A is invertible.

Suppose now that A is invertible and has an R_j -invertible shell. By multiple applications of Lemma 4.2.1.7, we get that $\psi_k \dots \psi_{n-1}A$ has an R_j -invertible shell, for $k \geq j$, and an R_k -invertible one for $k \leq j$. Applying Lemma 4.2.1.8 multiple times, we get that for all $k \leq j$, $\psi_k \dots \psi_{n-1}A$ is R_k -invertible, and finally that for all $k \geq j$, $\psi_k \dots \psi_{n-1}A$ is R_j -invertible. In particular for $k = n$, A is R_j -invertible.

Finally, if A is thin, then $\psi_1 \dots \psi_{n-1}A \in \mathbf{Im} \epsilon_1$ and so $R_1 \psi_1 \dots \psi_{n-1}A = \psi_1 \dots \psi_{n-1}A$ is thin. Multiple applications of Lemma 4.2.1.8 imply that $R_j A$ is thin. \square

Finally, the following Lemma will be useful in Proposition 4.2.3.5:

Lemma 4.2.2.3. *The composite of two invertible cells is also invertible.*

Proof. Let $1 \leq i \leq n$, and let E_i be the set of all cells $A \in \mathbf{C}_n$ such that $\psi_1 \dots \psi_{i-1}A$ is R_1 -invertible. Note first that E_i contains all R_i -invertible cells by Lemma 4.2.1.7 and that E_n is the set of all invertible cells. We are going to show by induction on i that E_i is closed under composition, for $1 \leq i \leq n$.

For $i = 1$, E_1 is the set of all R_1 -invertible cells, which is closed under composition by Lemma 4.2.1.4. Suppose now $i > 1$. Take $A, B \in E_i$. We have:

$$\psi_{i-1}(A \star_j B) = \begin{cases} \psi_{i-1}A \star_j \psi_{i-1}B & j \neq i, i-1 \\ (\psi_{i-1}A \star_i \epsilon_{i-1} \partial_i^+ B) \star_{i-1} (\epsilon_{i-1} \partial_i^- A \star_i \psi_{i-1}B) & j = i-1 \\ (\epsilon_{i-1} \partial_{i-1}^- A \star_i \psi_{i-1}B) \star_{i-1} (\psi_{i-1}A \star_i \epsilon_{i-1} \partial_{i-1}^+ B) & j = i \end{cases}$$

Note that:

- Since $\psi_1 \dots \psi_{i-1}A$ and $\psi_1 \dots \psi_{i-1}B$ are R_1 -invertible, $\psi_{i-1}A$ and $\psi_{i-1}B$ are in E_{i-1} .
- The cells $\epsilon_{i-1} \partial_k^\alpha A$ and $\epsilon_{i-1} \partial_k^\alpha B$ are R_{i-1} -invertible by Lemma 4.2.1.4, and therefore are in E_{i-1} .

By induction hypothesis, E_{i-1} is closed under composition, and therefore $\psi_{i-1}(A \star_j B)$ is in E_i . So $\psi_1 \dots \psi_{i-1}(A \star_j B)$ is R_1 -invertible, and so $A \star_j B$ is in E_i , which is therefore closed under composition. \square

4.2.3 T_i -invertibility

The notion of T_i -invertibility is closely related to that of R_i -invertibility, as we show in Lemma 4.2.3.3. Consequently, a number of results from the previous Section have analogues in terms of T_i -invertibility. In particular, the characterisation of T_i -invertibility in terms of invertibility given in Proposition 4.2.3.5 is the direct analogue of Proposition 4.2.2.2.

Definition 4.2.3.1. Let \mathbf{C} be a cubical ω -category, and $i < n$ be integers. Let A, B be cells in \mathbf{C}_n such that $\partial_i^\alpha A = \partial_{i+1}^\alpha B$ and $\partial_{i+1}^\alpha A = \partial_i^\alpha B$, for $\alpha = \pm$. If the following two equations are verified, we say that A is T_i -invertible, and that B is the T_i -inverse of A , and we denote B by $T_i A$:

$$\begin{array}{|c|c|} \hline \ulcorner & B \\ \hline A & \lrcorner \\ \hline \end{array} = \begin{array}{|c|c|} \hline \lrcorner & \ulcorner \\ \hline \end{array} \quad \begin{array}{c} \downarrow \rightarrow i \\ i+1 \end{array} \quad (4.2.5)$$

$$\begin{array}{|c|c|} \hline \ulcorner & A \\ \hline B & \lrcorner \\ \hline \end{array} = \begin{array}{|c|c|} \hline \lrcorner & \ulcorner \\ \hline \end{array} \quad \begin{array}{c} \rightarrow i \\ \downarrow \\ i+1 \end{array} \quad (4.2.6)$$

In particular, we say that $A \in \mathbf{C}_{n+1}$ has a T_i -invertible shell if ∂A is T_i -invertible in $\square_n \mathbf{C}$.

Remark 4.2.3.2. Note that $T_i A$ is uniquely defined. Indeed, if B and C are both T_i -inverses of A , then evaluating the following square in two different ways shows that $B = C$:

$$B = \begin{array}{|c|c|} \hline \ulcorner & B \\ \hline \lrcorner & | \\ \hline \ulcorner & \lrcorner \\ \hline \end{array} = \begin{array}{|c|c|c|} \hline & \ulcorner & B \\ \hline \ulcorner & A & \lrcorner \\ \hline C & \lrcorner & \\ \hline \end{array} = \begin{array}{|c|c|c|} \hline \ulcorner & \lrcorner & \ulcorner \\ \hline C & - & \lrcorner \\ \hline \end{array} = C \quad \begin{array}{c} \rightarrow i \\ \downarrow \\ i+1 \end{array}$$

The relationship between T_i and R_i -invertibility is given by the following Lemma.

Lemma 4.2.3.3. *Let \mathbf{C} be a cubical ω -category, and $A \in \mathbf{C}_n$ be an n -cell, with $n \geq 2$. Then A is T_i -invertible (with $i < n$) if and only if $\psi_i A$ is R_i -invertible, and we have the equalities:*

$$R_i \psi_i A = \psi_i T_i A \quad (4.2.7) \quad T_i A = \begin{array}{|c|c|} \hline | & \ulcorner \\ \hline R_i \psi_i A & \\ \hline \lrcorner & | \\ \hline \end{array} \quad \begin{array}{c} \rightarrow i+1 \\ \downarrow \\ i \end{array} \quad (4.2.8)$$

In particular, if A is thin, then so is $T_i A$.

Proof. Suppose first that A is T_i -invertible. Then the composite $\psi_i T_i A \star_i \psi_i A$ is equal to the following:

$$\begin{array}{|c|c|c|c|} \hline & \ulcorner & T_i A & \lrcorner \\ \hline \ulcorner & A & \lrcorner & \\ \hline \end{array} \quad \begin{array}{c} \rightarrow i \\ \downarrow \\ i+1 \end{array}$$

Using (4.2.5), we show that this composite is equal to $\epsilon_i \partial_i^+ \psi_i A$. We prove in the same way (using (4.2.6)), that $\psi_i A \star_i \psi_i T_i A = \epsilon_i \partial_i^- \psi_i A$, which shows that $\psi_i T_i A$ is the R_i -inverse of $\psi_i A$.

Suppose now that $\psi_i A$ is T_i -invertible. Then we have:

$$\begin{array}{|c|c|c|} \hline & | & \ulcorner \\ \hline & R_i \psi_i A & \\ \hline \ulcorner & \lrcorner & | \\ \hline A & - & \lrcorner \\ \hline \end{array} = \begin{array}{|c|c|c|c|} \hline & & | & \ulcorner \\ \hline & & R_i \psi_i A & \\ \hline & \ulcorner & \lrcorner & | \\ \hline \ulcorner & A & - & \lrcorner \\ \hline \lrcorner & | & & \\ \hline \end{array} = \begin{array}{|c|c|} \hline | & \ulcorner \\ \hline R_i \psi_i A & \\ \hline \psi_i A & \\ \hline \lrcorner & | \\ \hline \end{array} = \begin{array}{|c|c|} \hline \lrcorner & \ulcorner \\ \hline \end{array} \quad \begin{array}{c} \rightarrow i+1 \\ \downarrow \\ i \end{array}$$

Finally, if A is thin, then so is $\psi_i A$, and so is $R_i \psi_i A$ by Proposition 4.2.2.2. Equation (4.2.8) then shows that $T_i A$ is then thin. \square

Lemma 4.2.3.4. *Let \mathbf{C} be a cubical n -category. Let $1 \leq i < n$ and $A \in \square\mathbf{C}$. Then A is T_j -invertible if and only if for all $i \neq j, j+1$, A_i^α is T_{j_i} -invertible, and:*

$$\partial_i^\alpha T_j A = \begin{cases} T_{j_i} \partial_i^\alpha A & i \neq j, j+1 \\ \partial_{j+1}^\alpha A & i = j, \\ \partial_j^\alpha A & i = j+1, \end{cases} \quad (4.2.9)$$

In particular, if \mathbf{C} is a cubical ω -category, and a cell $A \in \mathbf{C}_n$ has a T_i -invertible shell, then $\partial_j^\alpha A$ is T_{i_j} -invertible for any $j \neq i, i+1$.

Proof. Suppose first that $A \in \square\mathbf{C}$ is T_j -invertible, and let $i \neq j, j+1$. Then we have:

$$\begin{aligned} \partial_i^\alpha T_j A &= \begin{array}{|c|c|} \hline \partial_i^\alpha \epsilon_j \partial_{j+1}^- A & \partial_i^\alpha \Gamma_j^+ \partial_j^+ A \\ \hline \partial_i^\alpha R_j \psi_j A & \\ \hline \partial_i^\alpha \Gamma_j^- \partial_j^- A & \partial_j^\alpha \epsilon_j \partial_{j+1}^+ A \\ \hline \end{array} \begin{array}{l} \xrightarrow{(j+1)_i} \\ \downarrow j_i \end{array} \\ &= \begin{array}{|c|c|} \hline \epsilon_{j_i} \partial_{(j+1)_i}^- \partial_i^\alpha A & \Gamma_{j_i}^+ \partial_{j_i}^+ \partial_i^\alpha A \\ \hline R_{j_i} \psi_j \partial_i^\alpha A & \\ \hline \Gamma_{j_i}^- \partial_{j_i}^- \partial_i^\alpha A & \epsilon_{j_i} \partial_{(j+1)_i}^+ \partial_i^\alpha A \\ \hline \end{array} \begin{array}{l} \xrightarrow{(j+1)_i} \\ \downarrow j_i \end{array} \\ &= T_{j_i} \partial_i^\alpha A \end{aligned}$$

For $i = j$, we have:

$$\begin{aligned} \partial_i^- T_i A &= \partial_i^- \epsilon_i \partial_{i+1}^- A \star_i \partial_i^- \Gamma_i^+ \partial_i^+ A & \partial_i^+ T_i A &= \partial_i^- \Gamma_i^- \partial_i^- A \star_i \partial_i^- \epsilon_i \partial_{i+1}^+ A \\ &= \partial_{i+1}^- A \star_i \epsilon_i \partial_i^- \partial_i^+ A & &= \epsilon_i \partial_i^+ \partial_i^- A \star_i \partial_{i+1}^+ A \\ &= \partial_{i+1}^- A & &= \partial_{i+1}^+ A \end{aligned}$$

Finally, for $i = j+1$:

$$\begin{aligned} \partial_{i+1}^- T_i A &= \partial_{i+1}^- \epsilon_i \partial_{i+1}^- A \star_i \partial_{i+1}^- R_i \psi_i A \star_i \partial_{i+1}^- \Gamma_i^- \partial_i^- A \\ &= \epsilon_i \partial_i^- \partial_{i+1}^- A \star_i R_i \epsilon_i \partial_i^\alpha \partial_{i+1}^\alpha A \star_i \partial_i^- A \\ &= \epsilon_i \partial_i^\alpha \partial_{i+1}^\alpha A \star_i \partial_i^- A = \partial_i^- A \end{aligned}$$

$$\partial_{i+1}^+ T_i A = \partial_{i+1}^+ \Gamma_i^+ \partial_i^+ A \star_i \partial_{i+1}^+ R_i \psi_i A \star_i \partial_{i+1}^+ \epsilon_i \partial_{i+1}^+ A$$

Reciprocally suppose that for all $i \neq j, j+1$, A_j^α is T_{j_i} -invertible. Then let $B_i^\alpha = T_{j_i} A_i^\alpha$ if $i \neq j, j+1$, $B_j^\alpha = A_{j+1}^\alpha$ and $B_{j+1}^\alpha = A_j^\alpha$. Then B is an element of $\square\mathbf{C}$, and we verify that it is the T_i -inverse of A . \square

Proposition 4.2.3.5. *Let \mathbf{C} be a cubical ω -category, and $A \in \mathbf{C}_n$, with $n \geq 2$. Then A is T_i -invertible if and only if A is invertible and has a T_i -invertible shell.*

Proof. Suppose A is T_i -invertible. Then $\psi_i A$ is R_i -invertible, and therefore it is invertible. Recall from [2] that A is equal to the following composite:

$$\begin{array}{|c|c|} \hline \lrcorner & \ulcorner \\ \hline \psi_i A & \\ \hline \lrcorner & \ulcorner \\ \hline \end{array} \begin{array}{l} \xrightarrow{i+1} \\ \downarrow i \end{array}$$

All the cells in this composite are invertible, and invertible cells are closed under composition (Lemma 4.2.2.3), therefore A is invertible. Moreover, since $\psi_i A$ is R_i -invertible, it has an R_i -invertible shell. In particular, for $j \neq i, i+1$, we have that $\partial_j^\alpha A = \partial_j^\alpha \psi_i A = \psi_{i_j} \partial_j^\alpha A$ is R_{i_j} -invertible. By Lemma 4.2.3.3, $\partial_j^\alpha A$ is T_{i_j} -invertible. So finally A has a T_j -invertible shell.

Suppose now that A is invertible and has a T_i -invertible shell. By application of Lemma 4.2.3.3 in $\square \mathbf{C}_n$, $\psi_i A$ is invertible and has an R_i -invertible shell. So $\psi_i A$ is R_i -invertible, and A is T_i -invertible by Lemma 4.2.3.3. \square

Proposition 4.2.3.6. *Let \mathbf{C} be a cubical ω -category.*

- Let $A \in \mathbf{C}_n$. For all $1 \leq j \leq n+1$, $\epsilon_j A$ is T_j and T_{j-1} -invertible and:

$$T_j \epsilon_j A = \epsilon_{j+1} A \quad T_{j-1} \epsilon_j A = \epsilon_{j-1} A \quad (4.2.10)$$

Moreover, if A is T_i -invertible (for $i \neq j-1$), then $\epsilon_j A$ is T_{ij} -invertible, and:

$$T_{ij} \epsilon_j A = \epsilon_j T_i A \quad (4.2.11)$$

- Let $A \in \mathbf{C}_n$. For all $1 \leq j \leq n$, $\Gamma_j^\alpha A$ is T_j -invertible, and

$$T_j \Gamma_j^\alpha A = \Gamma_j^\alpha A \quad (4.2.12)$$

Moreover, if A is T_i -invertible, then $\Gamma_j^\alpha A$ is T_{ij} -invertible, and:

$$T_{ij} \Gamma_j^\alpha A = \Gamma_j^\alpha T_i A \quad (4.2.13)$$

Finally, if A is T_i -invertible, then $\Gamma_{i+1}^\alpha A$ (resp. $\Gamma_i^\alpha A$) is T_i -invertible (resp. T_{i+1} -invertible) and $\Gamma_i^\alpha T_i A$ (resp. $\Gamma_{i+1}^\alpha T_i A$) is T_{i+1} -invertible (resp. T_i -invertible), and:

$$T_{i+1} \Gamma_i^\alpha T_i A = T_i \Gamma_{i+1}^\alpha A \quad T_i \Gamma_{i+1}^\alpha T_i A = T_{i+1} \Gamma_i^\alpha A \quad (4.2.14)$$

- Let $A, B \in \mathbf{C}_n$. If A and B are T_i -invertible, then $A \star_j B$ is T_i -invertible, and:

$$T_i(A \star_j B) = \begin{cases} (T_i A) \star_{i+1} (T_i B) & j = i, \\ (T_i A) \star_i (T_i B) & j = i+1, \\ (T_i A) \star_j (T_i B) & \text{otherwise.} \end{cases} \quad (4.2.15)$$

Proof. For the first seven equations, notice that both sides of the equations are thin by Lemma 4.2.3.3. Therefore, by Theorem 4.1.2.5, it is enough to check that their shells are equal.

For the last one, we return to the definition of T_i -invertibility. \square

4.3 Relationship of cubical (ω, p) -categories with other structures

In Section 4.3.1, we collect the results of Section 4.2 to give a series of equivalent characterisation of the invertibility in a cubical ω -category of all cells of dimension n (Proposition 4.3.1.2). From that we then deduce the equivalence between globular and cubical (ω, p) -categories (Theorem 4.3.1.3).

In Section 4.3.2, we generalise the adjunctions between globular ω -groupoids and chain complexes and the one between globular ω -categories and ADCs from [77]. To do so we introduce the notion of (ω, p) -ADCs, such that (ω, ω) -ADCs are just ADCs, and $(\omega, 0)$ -ADCs coincide with augmented chain complexes.

4.3.1 Cubical and globular (ω, p) -categories

In this Section we start by defining the notion of cubical (ω, p) -categories. In Proposition 4.3.1.2, we give various equivalent characterisations of those using the result from Section 4.2. As a result, we show Theorem 4.3.1.3 that the equivalence between globular and cubical ω -category induces equivalences between globular and cubical (ω, p) -categories. Finally, in Corollary 4.3.1.4 we give a simple characterisation of the notions of cubical $(\omega, 0)$ and $(\omega, 1)$ -categories.

Definition 4.3.1.1. Let \mathbf{C} be a cubical ω -category, and p a natural number. We say that \mathbf{C} is a *cubical (ω, p) -category* if any n -cell is invertible, for $n > p$. We denote by (ω, p) -**CubCat** the full subcategory of ω -**CubCat** spanned by cubical (ω, p) -categories.

Proposition 4.3.1.2. *Let \mathbf{C} be a cubical ω -category, and fix $n > 0$. The following five properties are equivalent:*

1. Any n -cell in \mathbf{C}_n is invertible.
2. For all $1 \leq i \leq n$, any n -cell in \mathbf{C}_n with an R_i -invertible shell is R_i -invertible.
3. Any n -cell in \mathbf{C}_n with an R_1 -invertible shell is R_1 -invertible.
4. Any n -cell $A \in \mathbf{C}_n$ such that for all $j \neq 1$, $\partial_j^\alpha A \in \mathbf{Im} \epsilon_1$ is R_1 -invertible.
5. Any n -cell in $\Phi_n(\mathbf{C}_n)$ is R_1 -invertible.

Moreover, if $n > 1$, then all the previous properties are also equivalent to the following:

6. For all $1 \leq i < n$, any n -cell in \mathbf{C}_n with a T_i -invertible shell is T_i -invertible
7. Any n -cell in \mathbf{C}_n with a T_1 -invertible shell is T_1 -invertible.

Proof. (1) \Rightarrow (2) holds by Proposition 4.2.2.2, (2) \Rightarrow (3) is clear, and (3) \Rightarrow (4) holds because if $A \in \mathbf{C}_n$ satisfies $\partial_j^\alpha A \in \mathbf{Im} \epsilon_1$, then its shell is R_1 -invertible. Also, (4) \Rightarrow (5) holds because for any $A \in \Phi_n(\mathbf{C}_n)$, $\partial_j^\alpha A \in \mathbf{Im} \epsilon_1$ for all $j \neq 1$. Let us finally show that (5) \Rightarrow (1). From Lemmas 4.2.1.7 and 4.2.1.8, for any $i < n$, a cell $A \in \mathbf{C}_n$ with an R_1 -invertible shell is R_1 -invertible if and only if $\psi_i A$. Iterating this result, we get that for all $A \in \mathbf{C}_n$ $\psi_1 \dots \psi_{n-1} A$ is R_1 -invertible if and only if $\Phi \psi_1 \dots \psi_{n-1} A$ is. Since $\Phi \psi_i = \Phi$ for all $i < n$, A is invertible if and only if ΦA is R_1 -invertible.

Suppose now $n > 1$. Then (1) \Rightarrow (6) by Proposition 4.2.3.5, and clearly (6) \Rightarrow (7). Suppose now that any n -cell with a T_1 -invertible shell is T_1 -invertible, and let us show that (4) holds. Let $A \in \mathbf{C}_n$ such that $\partial_j^\alpha A \in \mathbf{Im} \epsilon_1$ for all $j \neq 1$ is R_1 -invertible. Then A has a T_1 -invertible shell, and is therefore T_1 -invertible by hypothesis. So A is invertible, and since it has an R_1 -invertible shell, it is R_1 -invertible. \square

Theorem 4.3.1.3. *The functors λ and γ restrict to an equivalence of categories:*

$$\begin{array}{ccc}
 & \lambda & \\
 \swarrow & & \searrow \\
 (\omega, p)\text{-Cat} & \cong & (\omega, p)\text{-CubCat} \\
 \searrow & & \swarrow \\
 & \gamma &
 \end{array}$$

Proof. Let \mathbf{C} be a cubical (ω, p) -category. The globular ω -category $\gamma\mathbf{C}$ is a globular (ω, p) -category if and only if, for all $n > p$, every cell in $\Phi_n(\mathbf{C}_n)$ is R_1 -invertible. By Proposition 4.3.1.2, this is equivalent to \mathbf{C} being a cubical (ω, p) -category. Since $(\omega, p)\text{-Cat}$ and $(\omega, p)\text{-CubCat}$ are replete full sub-categories respectively of $\omega\text{-Cat}$ and $\omega\text{-CubCat}$, this proves the result. \square

Corollary 4.3.1.4. *Let \mathbf{C} be a cubical ω -category. Then:*

- \mathbf{C} is a cubical ω -groupoid if and only if every n -cell of \mathbf{C} is R_i -invertible for all $1 \leq i \leq n$.
- \mathbf{C} is a cubical $(\omega, 1)$ -category if and only if every n -cell is T_i -invertible, for all $1 \leq i < n$.

Proof. If every n -cell of \mathbf{C}_n is R_i -invertible then in particular every cell of \mathbf{C}_n is invertible, and so \mathbf{C} is a cubical ω -groupoid. Reciprocally, if \mathbf{C} is a cubical ω -groupoid, we prove by induction on n that every cell is R_i -invertible. For $n = 1$, every 1-cell has an R_1 -invertible shell, and so every cell is R_1 -invertible. Suppose now the property true for all n -cells. Then any cell $A \in \mathbf{C}_{n+1}$ necessarily has a R_i -invertible shell by Lemma 4.2.1.2, and so the property holds for all $(n + 1)$ -cells.

The proof of the second point is similar, using the fact that any 2-cell in a cubical ω -category has a T_1 -invertible shell. \square

4.3.2 Augmented directed complexes and (ω, p) -categories

From [2] and [77], we have the following functors, where \mathbf{ADC} is the category of augmented directed complexes.

$$\begin{array}{ccccc}
 & \mathcal{Z}^{\mathbf{G}} & & \lambda & \\
 \swarrow & & & \searrow & \\
 \mathbf{ADC} & \perp & \omega\text{-Cat} & \cong & \omega\text{-CubCat} \\
 \searrow & & & \swarrow & \\
 & \mathcal{N}^{\mathbf{G}} & & \gamma &
 \end{array}$$

In this section we define cubical analogues to $\mathcal{N}^{\mathbf{G}}$ and $\mathcal{Z}^{\mathbf{G}}$, and show that they induce an adjunction between \mathbf{ADC} and $\omega\text{-CubCat}$. Finally, we show that all these functors can be restricted to the case of (ω, p) -categories, with a suitable notion of $(\omega, p)\text{-ADC}$.

Definition 4.3.2.1. An *augmented chain complex* K is a sequence of abelian groups K_n (for $n \geq 0$) together with applications $d : K_{n+1} \rightarrow K_n$ for every $n \geq 0$ and an application $e : K_0 \rightarrow \mathbb{Z}$ satisfying the equations:

$$d \circ d = 0 \quad e \circ d = 0$$

A morphism of augmented chain complexes from $(K, d, e) \rightarrow (L, d, e)$ is a family of morphisms $f_n : K_n \rightarrow L_n$ satisfying:

$$d \circ f_{n+1} = f_n \circ d \quad e = e \circ f_0.$$

Definition 4.3.2.2. An *augmented directed chain complex* (or ADC for short) is an augmented chain complex K equipped with a submonoid K_n^* of K_n for any $n \geq 0$.

A morphism of ADCs $K \rightarrow L$ is a morphism of augmented chain complexes f satisfying $f(K_n^*) \subseteq L_n^*$. We denote by **ADC** the category of augmented directed chain complexes.

The following is a reformulation of Steiner [77]:

Proposition 4.3.2.3. *Let us fix $n \geq 0$, and let K the following ADC:*

$$K_k = \begin{cases} \mathbb{Z}[s_k, t_k] & k < n \\ \mathbb{Z}[x] & k = n \\ 0 & k > n \end{cases} \quad K_k^* = \begin{cases} \mathbb{N}[s_k, t_k] & k < n \\ \mathbb{N}[x] & k = n \\ 0 & k > n \end{cases} \quad \begin{cases} d[x] = t_{n-1} - s_{n-1} \\ d[s_{k+1}] = d[t_{k+1}] = t_k - s_k & k \geq 0 \\ e[s_0] = e[t_0] = 1 \end{cases}$$

We denote this ADC by $n\text{-}\bullet^{\text{ADC}}$. Equipped with morphisms $\check{s}, \check{t} : (n+1)\text{-}\bullet^{\text{ADC}} \rightarrow n\text{-}\bullet^{\text{ADC}}$, $\check{\Gamma} : n\text{-}\bullet^{\text{ADC}} \rightarrow (n+1)\text{-}\bullet^{\text{ADC}}$ and $\check{\star}_i : n\text{-}\bullet^{\text{ADC}} \sqcup_i \bullet^{\text{ADC}} \rightarrow n\text{-}\bullet^{\text{ADC}}$, those form a co globular ω -category object in **ADC**, and therefore they induce a functor $N^{\mathbf{G}} : \mathbf{ADC} \rightarrow \omega\text{-}\mathbf{Cat}$ defined by $(N^{\mathbf{G}}K)_n = \mathbf{ADC}(n\text{-}\bullet^{\text{ADC}}, K)$

The category **ADC** is equipped with a tensor product defined as follows [77]:

Definition 4.3.2.4. Let K and L be ADCs. We define an object $K \otimes L$ in **ADC** as follows:

- For all $n \geq 0$, $(K \otimes L)_n = \bigoplus_{i+j=n} K_i \otimes L_j$.
- For all $n \geq 0$, $(K \otimes L)_n^*$ is the sub-monoid of $(K \otimes L)_n$ generated by the elements of the form $x \otimes y$, with $x \in K_i^*$ and $y \in L_{n-i}^*$.
- For all $x \in K_i$ and $y \in L_{n-i}$, $d[x \otimes y] = d[x] \otimes y + (-1)^i x \otimes d[y]$.
- For all $x \in K_0$ and $y \in L_0$, $e[x \otimes y] = e[x]e[y]$.

Proposition 4.3.2.5. *Let \mathcal{C} be a globular ω -category. Following Steiner [77], we define an ADC $K = \mathcal{Z}^{\mathbf{G}}\mathcal{C}$ as follows:*

- For all $n \in \mathbb{N}$, K_n is the quotient of the group $\mathbb{Z}[\mathcal{C}_n]$ by the relation $[A \bullet_k B] = [A] + [B]$.
- For all $n \in \mathbb{N}$, K_n^* is the image of $\mathbb{N}[\mathcal{C}_n]$ in K_n .
- For all $A \in \mathcal{C}_n$, $d[A] = [s(A)] - [t(A)]$.
- For all $A \in \mathcal{C}_0$, $e[A] = 1$.

Proposition 4.3.2.6 ([77], Theorem 2.11). *The functor $\mathcal{Z}^{\mathbf{G}}$ is left-adjoint to the functor $N^{\mathbf{G}}$.*

$$\begin{array}{ccc} & \mathcal{Z}^{\mathbf{G}} & \\ & \curvearrowright & \\ \mathbf{ADC} & \perp & \omega\text{-}\mathbf{Cat} \\ & \curvearrowleft & \\ & N^{\mathbf{G}} & \end{array}$$

Definition 4.3.2.7. Let $n\text{-}\blacksquare^{\text{ADC}}$ be the augmented directed complex $\mathcal{Z}^{\mathbf{G}}(n\text{-}\blacksquare^{\mathbf{G}})$. The applications $\check{\delta}_i^\alpha$, $\check{\epsilon}_i$, $\check{\Gamma}_i^\alpha$ and $\check{\star}_i$ still induce a structure of co-cubical ω -category object in **ADC** on the family $n\text{-}\blacksquare^{\text{ADC}}$. Consequently, for any $K \in \mathbf{ADC}$ the family of sets $\mathbf{ADC}(n\text{-}\blacksquare^{\text{ADC}}, K)$ is equipped with a structure of cubical ω -category. This defines a functor $N^{\mathbf{C}} : \mathbf{ADC} \rightarrow \omega\text{-}\mathbf{CubCat}$.

Let \mathbf{C} be a cubical ω -category. We define an ADC $K = \mathcal{Z}^{\mathbf{C}}\mathbf{C}$ as follows:

- For all $n \in \mathbb{N}$, K_n is the quotient of $\mathbb{Z}[\mathbf{C}_n]$ by the relations $[A \star_k B] = [A] + [B]$ and $[\Gamma_i^\alpha A] = 0$.
- For all $n \in \mathbb{N}$, K_n^* is the image of $\mathbb{N}[\mathbf{C}_n]$ in K_n .
- For all $A \in \mathbf{C}_n$,

$$d[A] = \sum_{\substack{1 \leq i \leq n \\ \alpha = \pm}} \alpha(-1)^i [\partial_i^\alpha A]$$

- For all $A \in \mathbf{C}_0$, $e[A] = 1$.

Proposition 4.3.2.8. *There are isomorphisms of functors:*

$$\mathcal{Z}^{\mathbf{C}} \approx \mathcal{Z}^{\mathbf{G}} \circ \gamma \quad N^{\mathbf{C}} \approx \lambda \circ N^{\mathbf{G}}$$

As a result, we have the following diagram of equivalence and adjunctions between ω -**Cat**, ω -**CubCat** and **ADC**, where both triangles involving $\mathcal{Z}^{\mathbf{C}}$ and $\mathcal{Z}^{\mathbf{G}}$ and both triangles involving $N^{\mathbf{C}}$ and $N^{\mathbf{G}}$ commute up to isomorphism:

$$\begin{array}{ccc}
 \omega\text{-}\mathbf{Cat} & \begin{array}{c} \xrightarrow{\lambda} \\ \cong \\ \xleftarrow{\gamma} \end{array} & \omega\text{-}\mathbf{CubCat} \\
 \swarrow \mathcal{Z}^{\mathbf{G}} & \begin{array}{c} \dashv \\ N^{\mathbf{G}} \end{array} & \searrow N^{\mathbf{C}} \\
 & \mathbf{ADC} & \\
 \swarrow \mathcal{Z}^{\mathbf{C}} & & \searrow \mathcal{Z}^{\mathbf{C}}
 \end{array}$$

Proof. Let K be an **ADC**. We have for all $n \geq 0$, using the adjunction between $N^{\mathbf{G}}$ and $\mathcal{Z}^{\mathbf{G}}$:

$$\begin{aligned}
 \lambda \circ N^{\mathbf{G}}(K)_n &= \omega\text{-}\mathbf{Cat}(n\text{-}\blacksquare^{\mathbf{G}}, N^{\mathbf{G}}K) \\
 &\approx \mathbf{ADC}(\mathcal{Z}^{\mathbf{G}}(n\text{-}\blacksquare^{\mathbf{G}}), K) \\
 &= \mathbf{ADC}(n\text{-}\blacksquare^{\mathbf{ADC}}, K) \\
 &= (N^{\mathbf{C}}K)_n
 \end{aligned}$$

Moreover, because these equalities are functorial, they preserve the cubical ω -category structures on the families $\lambda \circ N^{\mathbf{G}}(K)_n$ and $(N^{\mathbf{C}}K)_n$. So finally we have the isomorphism $N^{\mathbf{C}} \approx \lambda \circ N^{\mathbf{G}}$.

Let now \mathbf{C} be a cubical ω -category. For all $n \geq 0$, the group $\mathcal{Z}^{\mathbf{G}}(\gamma(\mathbf{C}))_n$ is the free abelian group generated by elements $[A]$, for $A \in \mathbf{Im} \Phi_n$, subject to the relations $[A \star_i B] = [A] + [B]$, for all $A, B \in \mathbf{Im} \Phi_n$. Let us show that for all $n \geq 0$, $\mathcal{Z}^{\mathbf{G}}(\gamma(\mathbf{C}))_n$ and $\mathcal{Z}^{\mathbf{C}}(\mathbf{C})_n$ are isomorphic.

First, the inclusion $\mathbf{Im} \Phi_n \rightarrow \mathbf{C}_n$ gives rise to an application $\mathbb{Z}[\mathbf{Im} \Phi_n] \rightarrow \mathcal{Z}^{\mathbf{C}}(\mathbf{C})_n$. Moreover, this application respects the relations defining $\mathcal{Z}^{\mathbf{G}}(\gamma(\mathbf{C}))_n$, so it induces a morphism $\iota: \mathcal{Z}^{\mathbf{G}}(\gamma(\mathbf{C}))_n \rightarrow \mathcal{Z}^{\mathbf{C}}(\mathbf{C})_n$.

For all $A \in \mathbf{C}_n$, we have in $\mathcal{Z}^{\mathbf{C}}(\mathbf{C})_n$: $[\psi_i A] = [\Gamma_i^+ \partial_{i+1}^- A] + [A] + [\Gamma_i^- \partial_{i+1}^+ A] = [A]$. By iterating this formula, we get that for all $A \in \mathbf{C}_n$, $[\Phi_n(A)] = [A]$. Hence, ι is surjective. Let us now show that it is injective. Using the relation $[\Phi_n(A)] = [A]$, we get that $\mathcal{Z}^{\mathbf{C}}(\mathbf{C})_n$ is isomorphic to the free group generated by $[\mathbf{Im} \Phi_n]$, subject to the relations $[\Phi_n(A \star_i B)] = [\Phi_n(A)] + [\Phi_n(B)]$ for all $A, B \in \mathbf{C}_n$ and $[\Phi_n(\Gamma_i^\alpha A)] = 0$, for all $A \in \mathbf{C}_{n-1}$. Let us prove that these equalities already hold in $\mathcal{Z}^{\mathbf{G}}(\gamma(\mathbf{C}))_n$.

Let x be a thin cell in \mathbf{C}_n . Then $\Phi_n(x)$ is in the image of ϵ_1 , and $\Phi_n(x) \star_1 \Phi_n(x) = \Phi_n(x)$, and so in $\mathcal{Z}^{\mathbf{G}}(\gamma(\mathbf{C}))_n$: $2 \cdot [\Phi_n(x)] = [\Phi_n(x)]$, and finally $[\Phi_n(x)] = 0$. In particular $[\Phi_n(\Gamma_i^\alpha A)] = 0$ in $\mathcal{Z}^{\mathbf{G}}(\gamma(\mathbf{C}))_n$. Let now A and B be i -composable n -cells. Following Proposition 6.8 from [2], $\Phi_n(A \star_i B)$ is a composite of cells of the form $\epsilon_1^{n-m} \Phi_m DA$ and $\epsilon_1^{n-m} \Phi_m DB$, where $0 \leq m \leq n$ is an integer, and D is a composite of length m of faces operations. Using the fact that $\epsilon_1^{n-m} \Phi_m = \Phi_n \epsilon_1^{n-m}$, we get that $\Phi_n(A \star_i B)$ is a composite of cells $\Phi_n(x)$, where x is thin, with the cells $\Phi_n(A)$ and $\Phi_n(B)$. So in $\mathcal{Z}^{\mathbf{G}}(\gamma(\mathbf{C}))_n$, $[\Phi_n(A \star_i B)] = k_1[\Phi_n(A)] + k_2[\Phi_n(B)]$ for some integers k_1 and k_2 . Moreover, following Section 6 of [2], we verify that the cells $\Phi_n A$ and $\Phi_n B$ appear exactly once in this composition. As a result $[\Phi_n(A \star_i B)] = [\Phi_n(A)] + [\Phi_n(B)]$ in $\mathcal{Z}^{\mathbf{G}}(\gamma(\mathbf{C}))_n$. So $\mathcal{Z}^{\mathbf{G}}(\gamma(\mathbf{C}))_n$ and $\mathcal{Z}^{\mathbf{C}}(\mathbf{C})_n$ are isomorphic.

Let us denote respectively by $d^{\mathbf{G}}$ and $d^{\mathbf{C}}$ the boundary applications in $\mathcal{Z}^{\mathbf{G}}(\gamma(\mathbf{C}))$ and $\mathcal{Z}^{\mathbf{C}}(\mathbf{C})_n$. For $A \in \mathbf{Im}(\Phi_n)$, we have $d^{\mathbf{G}}[A] = [\partial_1^- A] - [\partial_1^+ A]$, and $d^{\mathbf{C}}[A] = \sum_{\alpha=\pm} \alpha (-1)^i [\partial_i^\alpha A]$. Since A is in $\mathbf{Im} \Phi_n$, for all $i \neq 1$, $\partial_i^\alpha A$ is thin. So $[\partial_i^\alpha A] = 0$, and $d^{\mathbf{C}}[A] = [\partial_1^- A] - [\partial_1^+ A] = d^{\mathbf{G}}[A]$. So ι induces an isomorphism of chain complexes between $\mathcal{Z}^{\mathbf{G}}(\gamma(\mathbf{C}))$ and $\mathcal{Z}^{\mathbf{C}}(\mathbf{C})$. Finally, $\mathcal{Z}^{\mathbf{G}}(\gamma(\mathbf{C}))_n^*$ and $\mathcal{Z}^{\mathbf{C}}(\mathbf{C})_n^*$ are the submonoids respectively generated by $\mathbf{Im} \Phi_n$ and \mathbf{C}_n and $[A] = [\Phi_n(A)]$ in $\mathcal{Z}^{\mathbf{C}}(\mathbf{C})_n$, so $\mathcal{Z}^{\mathbf{G}}(\gamma(\mathbf{C}))$ and $\mathcal{Z}^{\mathbf{C}}(\mathbf{C})$ are isomorphic as ADCs. \square

Definition 4.3.2.9. Let K be an ADC. We say that a cell $A \in K_n^*$ is *invertible* if $-A$ is in K_n^* .

We say that K is an (ω, p) -ADC if for any $n > p$, $K_n = K_n^*$. We denote by (ω, p) -ADC the category of (ω, p) -ADCs.

Proposition 4.3.2.10. Let \mathcal{C} be a globular ω -category, and $A \in \mathcal{C}_n$. If A is invertible, then so is $[A]$ in $\mathcal{Z}^{\mathbf{G}}(\mathcal{C})$, and $[A^{-1}] = -[A]$. In particular if \mathcal{C} is an (ω, p) -category, then $\mathcal{Z}^{\mathbf{G}}\mathcal{C}$ is an (ω, p) -ADC.

Let K be an ADC, and $A \in \mathbf{ADC}(n\text{-}\bullet^{\mathbf{ADC}}, K)$. If $A[(x)] \in K_n^*$ is invertible then so is A in $N^{\mathbf{G}}(K)$, and the inverse of A is given by:

$$B[x] = -A[x] \quad \begin{cases} B[s_{n-1}] = A[t_{n-1}] \\ B[t_{n-1}] = A[s_{n-1}] \end{cases} \quad \begin{cases} B[s_i] = A[s_i] & i < n-1 \\ B[t_i] = A[t_i] & i < n-1 \end{cases}$$

In particular if K is an (ω, p) -ADC then $N^{\mathbf{G}}K$ is a globular (ω, p) -category.

Proof. Let \mathcal{C} be an ω -category, and $A \in \mathcal{C}_n$. If A is invertible, then there exists B such that $A \bullet_n B = 1_{s(A)}$. Notice first that $[1_{s(A)}] + [1_{s(A)}] = [1_{s(A)} \bullet_n 1_{s(A)}] = [1_{s(A)}]$, and therefore $[1_{s(A)}] = 0$. So finally $[A] + [B] = [A \bullet_n B] = 0$. Since both $[A]$ and $[B]$ are in $\mathcal{Z}^{\mathbf{G}}(\mathcal{C})_n^*$, $[A]$ is invertible. If \mathcal{C} is an (ω, p) -category, then for all $n > p$, $(\mathcal{Z}^{\mathbf{G}}\mathcal{C})_n^*$ is generated by invertible cells. Since invertible cells are closed under addition, $(\mathcal{Z}^{\mathbf{G}}\mathcal{C})_n^*$ is actually a group. Moreover, it has the same generators as $(\mathcal{Z}^{\mathbf{G}}\mathcal{C})_n$, so the two groups are actually equal, making $\mathcal{Z}^{\mathbf{G}}\mathcal{C}$ an (ω, p) -ADC.

Let now K be an ADC, and $A \in \mathbf{ADC}(n\text{-}\bullet^{\mathbf{ADC}}, K)$ such that $A[x]$ is invertible. Define B as the following morphism from $n\text{-}\bullet^{\mathbf{ADC}}$ to K :

$$B[x] = -A[x] \quad \begin{cases} B[s_{n-1}] = A[t_{n-1}] \\ B[t_{n-1}] = A[s_{n-1}] \end{cases} \quad \begin{cases} B[s_i] = A[s_i] & i < n-1 \\ B[t_i] = A[t_i] & i < n-1 \end{cases}$$

Note that since $A[x]$ is invertible, $-A[x]$ is in K_n^* , and so B is indeed a morphism of ADC. Moreover, A and B are $(n-1)$ -composable, and $A \bullet_{n-1} B$ is given by:

$$(A \bullet_{n-1} B)[x] = A[x] - A[x] = 0 \quad \begin{cases} (A \bullet_{n-1} B)[s_{n-1}] = A[s_{n-1}] \\ (A \bullet_{n-1} B)[t_{n-1}] = B[t_{n-1}] = A[s_{n-1}] \end{cases} \quad \begin{cases} (A \bullet_{n-1} B)[s_i] = A[s_i] \\ (A \bullet_{n-1} B)[t_i] = A[s_i] \end{cases}$$

So $A \bullet_{n-1} B = 1_{s(A)}$, and symmetrically $B \bullet_{n-1} A = 1_{t(A)}$. The cell A is thus invertible. In particular if K is an (ω, p) -ADC, then for all $n > p$ and all $A \in \mathbf{ADC}(n\text{-}\bullet^{\mathbf{ADC}}, K)$, $A[x]$ is invertible and A is invertible. So every cell in $(N^{\mathbf{G}}K)_n$ is invertible, and finally $N^{\mathbf{G}}K$ is an (ω, p) -category. \square

Recall from [77] that $n\text{-}\blacksquare_k^{\mathbf{ADC}}$ is the free abelian group over the set $n\text{-}\blacksquare_k^{\mathbf{Set}}$ of sequences $s : \{1, \dots, n\} \rightarrow \{(-), (\theta), (+)\}$ such that $|s^{-1}(\theta)| = k$. For any such s , and any $1 \leq i \leq n$ such that $s(i) \neq (\theta)$, we denote by $R_i s$ the sequence obtained by replacing $s(i)$ by $-s(i)$ in s . The following Proposition is the cubical analogue of the previous one.

Proposition 4.3.2.11. *Let \mathbf{C} be a cubical ω -category, and $A \in \mathbf{C}_n$. If A is R_i -invertible or T_i -invertible, then $[A]$ is invertible. In particular if \mathbf{C} is a cubical (ω, p) -category, then $\mathcal{Z}^{\mathbf{C}}\mathbf{C}$ is an (ω, p) -ADC.*

Let K be an ADC, and let $A \in \mathbf{ADC}(n\text{-}\blacksquare^{\mathbf{ADC}}, K)$:

- If for any $0 \leq k \leq n$, and any sequence $s \in n\text{-}\blacksquare_k^{\mathbf{Set}}$ such that $s(i) = (\theta)$, $A[s]$ is invertible (in K) then A is R_i -invertible, and $R_i A$ is given by:

$$R_i A[s] = \begin{cases} -A[s] & s(i) = (\theta) \\ A[R_i s] & s(i) \neq (\theta) \end{cases}$$

- If for any $0 \leq k \leq n$, and any sequence $s \in n\text{-}\blacksquare_k^{\mathbf{Set}}$ such that $s(i) = s(i+1) = (\theta)$, $A[s]$ is invertible, then A is T_i -invertible, and $T_i A$ is given by:

$$T_i A[s] = \begin{cases} -A[s] & s(i) = s(i+1) = (\theta) \\ A[s \circ \tau_i] & \text{otherwise.} \end{cases}$$

In particular, if K is an (ω, p) -ADC, then $N^{\mathbf{C}}K$ is a cubical (ω, p) -category.

Proof. The proof is similar to that of the previous Proposition. \square

Theorem 4.3.2.12. *For all $p \in \mathbb{N} \cup \{\omega\}$, the categories (ω, p) -**Cat**, (ω, p) -**CubCat** and (ω, p) -**ADC** are related by the following diagram of equivalence and adjunctions, where both triangles involving $\mathcal{Z}^{\mathbf{C}}$ and $\mathcal{Z}^{\mathbf{G}}$ and both triangles involving $N^{\mathbf{C}}$ and $N^{\mathbf{G}}$ commute up to isomorphism:*

$$\begin{array}{ccc} (\omega, p)\text{-}\mathbf{Cat} & \begin{array}{c} \xrightarrow{\lambda} \\ \xrightarrow{\cong} \\ \xleftarrow{\gamma} \end{array} & (\omega, p)\text{-}\mathbf{CubCat} \\ & \begin{array}{c} \swarrow \mathcal{Z}^{\mathbf{G}} \\ \searrow N^{\mathbf{G}} \end{array} & \begin{array}{c} \swarrow N^{\mathbf{C}} \\ \searrow \mathcal{Z}^{\mathbf{C}} \end{array} \\ & & (\omega, p)\text{-}\mathbf{ADC} \end{array}$$

Proof. We have already proven that the equivalence between ω -**Cat** and ω -**CubCat** could be restricted to (ω, p) -categories in Theorem 4.3.1.3, and by Propositions 4.3.2.10 and 4.3.2.11, so can the two adjunctions. Lastly, the commutations up to isomorphisms come from Proposition 4.3.2.8. \square

Remark 4.3.2.13. In the case where $p = 0$, one would expect the previous Theorem to recover the usual adjunction between chain complexes and groupoids. However, the category of $(\omega, 0)$ -ADCs is not the category of chain complexes, but that of chain complexes K equipped with a distinguished sub-monoid of K_0 .

In order to recover the adjunction between groupoids and chain complexes, one could use a variant of the notion of ADC that does not specify a distinguished submonoid of K_0 . Then an $(\omega, 0)$ -ADC is indeed just a chain complex. One can check that, *mutatis mutandis*, the results of this Section, and in particular Theorem 4.3.2.12, still hold using this alternative definition.

4.4 Permutations in cubical (ω, p) -categories

We now apply our results from the previous Section. First, we show in Section 4.4.1 that the operations T_i induce a partial action of the symmetric group S_n on the n -cells of a cubical ω -category. To do this, we define a general notion of σ -invertibility, where $\sigma \in S_n$. In particular when σ is a transposition τ_i we recover the notion of T_i -invertibility of Section 4.2.3. In Section 4.4.2, we define the notions of lax and oplax transfors between cubical categories.

Then we then define what it means for a tranfor to be pseudo using the notion of σ -invertibility defined previously and finally we show that the cubical ω -categories of pseudo lax and oplax transfors between two cubical ω -categories are isomorphic

4.4.1 Cubical $(\omega, 1)$ -categories are symmetric

We start by defining a notion of u -invertibility, where u is a word over T_1, \dots, T_i , and characterise the notion of u -invertibility in terms of plain invertibility, just as we have done previously for R_i and T_i -invertibility.

We then show how the notion of u -invertibility induces a notion of σ -invertibility, for $\sigma \in S_n$. The difficulty lies in the fact that, even if two words u and v over T_1, \dots, T_i correspond to the same permutations, the notions of u and v -invertibility do not necessarily coincide. We circumvent this difficulty by using a classical result about the symmetric group (see Theorem 4.4.1.12), which makes use of the notion of representative of minimal length of permutation.

Finally, in Proposition 4.4.1.14 we extend the results concerning u -invertibility to σ -invertibility, with $\sigma \in S_n$.

Definition 4.4.1.1. Let $n \in \mathbb{N}$. We write \mathbb{T}_n the free monoid on $n - 1$ elements. We denote its generators by T_1, \dots, T_{n-1} , and by $1 : \mathbb{T}_n \rightarrow \mathbb{N}$ the morphism of monoids that sends every T_i on 1. For $u \in \mathbb{T}_n$, we call $l(u)$ the *length* of u .

Recall that S_n is a quotient of \mathbb{T}_n using the relations:

$$T_i T_i = 1 \tag{4.4.1}$$

$$T_i T_{i+1} T_i = T_{i+1} T_i T_{i+1} \tag{4.4.2}$$

$$T_j T_i = T_j T_i \quad |i - j| \geq 2 \tag{4.4.3}$$

We denote by \bar{u} the image of an element $u \in \mathbb{T}_n$ in S_n , and $\tau_i = \bar{T}_i$. Using this projection, one defines a right-action of \mathbb{T}_n on $\{1, \dots, n\}$ by setting $k \cdot u := k \cdot \bar{u}$.

Let \mathbf{C} be a cubical ω -category. For every $u \in \mathbb{T}_n$, we define a notion of u -invertible cell and a partial application $u \cdot _ : \mathbf{C}_n \rightarrow \mathbf{C}_n$ defined on u -invertible cells as follows:

- Any n -cell of \mathbf{C}_n is 1-invertible, and $1 \cdot A = A$.
- For any $u \in \mathbb{T}_n$ and $1 \leq i < n$, a cell $A \in \mathbf{C}_n$ is said to be $(T_i \cdot u)$ -invertible if A is u -invertible and $u \cdot A$ is T_i -invertible. Moreover, we set: $(T_i \cdot u) \cdot A := T_i(u \cdot A)$.

In particular, we say that A has a u -invertible shell if ∂A is u -invertible in $\square_n \mathbf{C}$.

Proposition 4.4.1.2. *Let \mathbf{C} be a cubical ω -category, and A be an n -cell in \mathbf{C} , with $n \geq 2$. Let $u \in \mathbb{T}_n$. Suppose $u \neq 1$. Then A is u -invertible if and only if A is invertible and has a u -invertible shell.*

Proof. We reason by induction on the length of u . If u is of length 1, there exists $1 \leq i < n$ such that $u = T_i$, and the result to prove becomes: A is T_i -invertible if and only if A is invertible and has a T_i -invertible shell, which is exactly Proposition 4.2.3.5.

Otherwise, write $u = T_i v$, with $v \neq 1$. Suppose A is u -invertible. Then by definition A is v -invertible, and $v \cdot A$ is T_i -invertible. By induction A is therefore invertible, and has a v -invertible shell. Moreover, $v \cdot A$ is T_i -invertible, and hence has a T_i -invertible shell by Proposition 4.2.3.5. Since $\partial(v \cdot A) = v \cdot \partial A$, ∂A is v -invertible, and $v \cdot A$ is T_i -invertible. Therefore, ∂A is u -invertible.

Reciprocally, suppose A is invertible, and has a $(T_i \cdot v)$ -invertible shell. Then A has a v -invertible shell, and $v \cdot \partial A$ is T_i -invertible. Since A is also invertible, by induction A is v -invertible, and since $\partial(v \cdot A) = v \cdot \partial A$, the cell $v \cdot A$ has a T_i -invertible shell. Moreover, it is invertible, and so by Proposition 4.2.3.5, $v \cdot A$ is T_i -invertible, which means that A is u -invertible. \square

Definition 4.4.1.3. For $1 \leq i \leq n$, we define applications $\partial_i : \mathbb{T}_n \rightarrow \mathbb{T}_{n-1}$ as follows:

$$\partial_i 1 = 1 \quad \partial_i T_j = \begin{cases} 1 & i = j, j + 1 \\ T_{j_i} & i \neq j, j + 1 \end{cases} \quad \partial_i(u \cdot v) = \partial_i u \cdot \partial_{i \cdot u} v.$$

Note in particular that the applications ∂_i are *not* morphisms of monoids.

Lemma 4.4.1.4. Let $u \in \mathbb{T}_n$. For all $1 \leq i \leq n$, and $1 \leq k \leq n$, we have:

$$k \cdot \partial_i u = (k^i \cdot u)_{i \cdot u}$$

Proof. Note first the formula holds when u is 1 or a T_j . Finally, suppose the property holds for u and v . Then we have:

$$\begin{aligned} k \cdot \partial_i(u \cdot v) &= k \cdot \partial_i u \cdot \partial_{i \cdot u} v = (k^i \cdot u)_{i \cdot u} \cdot \partial_{i \cdot u} v \\ &= ((k^i \cdot u)_{i \cdot u} \cdot v)_{i \cdot u \cdot v} = (k^i \cdot u \cdot v)_{i \cdot u \cdot v} \end{aligned}$$

\square

Lemma 4.4.1.5. Let \mathbf{C} be a cubical n -category, $A \in (\square \mathbf{C})_{n+1}$ and $u \in \mathbb{T}_{n+1}$. The cell A is u -invertible if and only if for all $j \leq n + 1$, $A_{j \cdot u}^\alpha$ is $\partial_j u$ -invertible, and:

$$\partial_j^\alpha(u \cdot A) = \partial_j u \cdot \partial_{j \cdot u}^\alpha A$$

In particular, if \mathbf{C} is a cubical ω -category, then $A \in \mathbf{C}_{n+1}$ has a u -invertible shell if and only if for all $j \leq n + 1$, $\partial_{j \cdot u}^\alpha A$ is $\partial_j u$ -invertible.

Proof. We reason by induction on the length of u . If u is of length 0, then $u = 1$ and for all j , $\partial_j u = 1$. Therefore, both conditions are empty, and $(1 \cdot A)_j^\alpha = A_j^\alpha$.

Otherwise, write $u = T_i \cdot v$. Suppose that A is u -invertible. Then A is v -invertible, and $v \cdot A$ is T_i -invertible. Fix j and α . Then $\partial_j u = T_{i_j} \cdot \partial_{j \cdot T_i} v$. Let us show that $A_{j \cdot u}^\alpha$ is $\partial_j u$ -invertible. We distinguish two cases:

- If $j = i$ (resp. $j = i + 1$), then $\partial_j u = \partial_{i+1} v$ (resp. $\partial_j v$), and $j \cdot u = (i + 1) \cdot v$ (resp. $i \cdot v$). By induction, $A_{(i+1) \cdot v}^\alpha$ (resp. $A_{i \cdot v}^\alpha$) is $\partial_{i+1} v$ -invertible (resp. $\partial_i v$ -invertible).
- Otherwise, then $\partial_j u = T_{i_j} \cdot \partial_j v$ and $j \cdot u = j \cdot v$. By induction hypothesis, $A_{j \cdot v}^\alpha$ is $\partial_j v$ -invertible. Let us show that $\partial_j v \cdot A_{j \cdot v}^\alpha$ is T_{i_j} -invertible. First since A is $T_i \cdot v$ -invertible, $v \cdot A$ is T_i -invertible, and so by Lemma 4.2.3.4, $\partial_j^\alpha(v \cdot A)$ is T_{i_j} -invertible. Finally, by induction, $\partial_j^\alpha(v \cdot A) = \partial_j v \cdot A_{j \cdot v}^\alpha$.

Finally, using the induction property on v , we get:

$$(u \cdot A)_j^\alpha = (T_i \cdot v \cdot A)_j^\alpha = \begin{cases} (v \cdot A)_{i+1}^\alpha = \partial_{i+1} v \cdot A_{(i+1) \cdot v}^\alpha = \partial_i u \cdot A_{i \cdot u}^\alpha & j = i \\ (v \cdot A)_i^\alpha = \partial_i v \cdot A_{i \cdot v}^\alpha = \partial_{i+1} u \cdot A_{(i+1) \cdot u}^\alpha & j = i + 1 \\ T_{i_j}(\partial_j v \cdot A)_j^\alpha = T_{i_j} \partial_j v \cdot A_{j \cdot v}^\alpha = \partial_j u \cdot A_{j \cdot u}^\alpha & j \neq i, i + 1 \end{cases}$$

Suppose now that for all j , $A_{j \cdot u}^\alpha$ is $\partial_j u$ -invertible. Let us show that A is u -invertible. First, let us prove that A is v -invertible. Indeed, let $j \leq n$, and let us show that $A_{j \cdot v}$ is $\partial_j v$ -invertible.

- If $j \neq i, i + 1$, we have that $A_{j \cdot u}^\alpha$ is $\partial_j u$ -invertible. Since $\partial_j u = T_{i_j} \partial_j v$, and $j \cdot u = j \cdot v$, this means that $A_{j \cdot v}^\alpha$ is $\partial_j v$ -invertible and $\partial_j v \cdot A_{j \cdot v}^\alpha$ is T_{i_j} -invertible.
- If $j = i$ (resp. $j = i + 1$) then $\partial_{i+1} u = \partial_i v$ (resp. $\partial_i u = \partial_{i+1} v$) and $(i + 1) \cdot u = i \cdot v$ (resp. $i \cdot u = (i + 1) \cdot v$). So $A_{j \cdot v}^\alpha$ is $\partial_j v$ -invertible.

Finally, by induction, A is v -invertible. Let us show that $v \cdot A$ is T_i -invertible. Indeed, for $j \neq i, i + 1$, $(v \cdot A)_j^\alpha = \partial_j v \cdot A_{j \cdot v}^\alpha$ is T_{i_j} -invertible, and so $v \cdot A$ is T_i -invertible by Lemma 4.2.3.4. \square

Lemma 4.4.1.6. *Let \mathbf{C} be a cubical ω -category.*

- If A is $T_i T_i$ -invertible, then:

$$T_i T_i \cdot A = A \quad (4.4.4)$$

- A cell $A \in \mathbf{C}_n$ is $T_i T_{i+1} T_i$ -invertible if and only if it is $T_{i+1} T_i T_{i+1}$ -invertible, and

$$T_i T_{i+1} T_i \cdot A = T_{i+1} T_i T_{i+1} \cdot A \quad (4.4.5)$$

- Let $i, j < n$ such that $|i - j| \geq 2$. A cell $A \in \mathbf{C}_n$ is $T_i T_j$ -invertible if and only if it is $T_j T_i$ -invertible, and

$$T_i T_j \cdot A = T_j T_i \cdot A \quad (4.4.6)$$

Proof. For the first one, notice that the axioms (4.2.5) and (4.2.6) are each other's symmetric, meaning that if B is the T_i -inverse of A , then A is the T_i -inverse of A . This means in particular that $T_i T_i \cdot A = A$.

For the second one, a cell $A \in \mathbf{C}_n$ is $T_i T_{i+1} T_i$ -invertible if and only if it is invertible and ∂A is $T_i T_{i+1} T_i$ -invertible, that is for all $j \leq n$, $\partial_{j \cdot T_i T_{i+1} T_i}^\alpha A$ is $\partial_j(T_i T_{i+1} T_i)$ -invertible. Notice that:

$$\partial_j(T_i T_{i+1} T_i) = \begin{cases} T_{i_j} T_{i_{j+1}} T_{i_j} & j \neq i, i + 1, i + 2 \\ T_i & j = i, i + 1, i + 2 \end{cases} \quad \partial_j(T_{i+1} T_i T_{i+1}) = \begin{cases} T_{i_{j+1}} T_{i_j} T_{i_{j+1}} & j \neq i, i + 1, i + 2 \\ T_i & j = i, i + 1, i + 2 \end{cases} \quad (4.4.7)$$

Therefore, by induction on n , a cell is $T_i T_{i+1} T_i$ -invertible if and only if it is $T_{i+1} T_i T_{i+1}$ -invertible. Let A be such a cell. Let us show that $T_i T_{i+1} T_i \cdot A$ is the T_{i+1} -inverse of $T_i T_{i+1} \cdot A$. Indeed, we have:

$$\begin{array}{|c|c|} \hline \Gamma_{i+1}^+(T_i \cdot \partial_i^- A) & T_i T_{i+1} \cdot A \\ \hline T_i T_{i+1} T_i \cdot A & \Gamma_{i+1}^-(T_i \cdot \partial_{i+1}^+ A) \\ \hline \end{array} \begin{array}{c} \downarrow \xrightarrow{i+1} \\ i+2 \end{array} = T_i T_{i+1} \cdot \begin{array}{|c|c|} \hline \Gamma_i^+ \partial_i^- A & A \\ \hline T_i \cdot A & \Gamma_i^- \partial_{i+1}^+ A \\ \hline \end{array} \begin{array}{c} \downarrow \xrightarrow{i} \\ i+1 \end{array}$$

$$\begin{aligned} &= T_i T_{i+1} \cdot (\Gamma_i^- \partial_{i+1}^+ A \star_i \Gamma_i^+ \partial_i^+ A) \\ &= (T_i T_{i+1} \cdot \Gamma_i^- \partial_{i+1}^+ A) \star_{i+1} (T_i T_{i+1} \cdot \Gamma_i^+ \partial_i^+ A) \\ &= \Gamma_{i+1}^- \partial_{i+2}^-(T_i T_{i+1} \cdot A) \star_{i+1} \Gamma_{i+1}^+ \partial_{i+1}^+(T_i T_{i+1} \cdot A) \end{aligned}$$

The other axioms are verified in the same fashion. \square

Remark 4.4.1.7. The first point of the previous Lemma is the main reason why the notion of u -invertibility relies on the monoid \mathbb{T}_n and not S_n . Indeed for \mathbf{C} a cubical ω -category, any cell is 1-invertible while the only cells $T_i T_i$ -invertible are the T_i -invertible ones.

Definition 4.4.1.8. A symmetric cubical ω -category \mathbf{C} is a cubical ω -category \mathbf{C} equipped with *total* applications $T_i : \mathbf{C}_n \rightarrow \mathbf{C}_n$, for $1 \leq i \leq n - 1$, satisfying the equalities (4.2.9) to (4.2.14) and (4.4.4) to (4.4.6).

Remark 4.4.1.9. Note that a symmetric cubical ω -category is close but not the same as the notion of symmetric cubical category defined by Grandis in [34]. A symmetric cubical category in the sense of Grandis would be a symmetric cubical ω -category (in the sense of 4.4.1.8, but without connections) object in the category \mathbf{Cat} .

Proposition 4.4.1.10. *Let \mathbf{C} be a cubical $(\omega, 1)$ -category. The applications $A \mapsto T_i A$ induce a structure of symmetric cubical category on \mathbf{C} .*

Proof. Any cell is T_i -invertible in a cubical $(\omega, 1)$ -category by Corollary 4.3.1.4 and so the applications are indeed total. Moreover and the equations they verify are a consequence of Proposition 4.2.3.6 and Lemma 4.4.1.6. \square

We now make explicit the (partial) action of the symmetric groups on the n -cells of a cubical category. To do so, we rely on Theorem 4.4.1.12, a classical result about the symmetric group.

Definition 4.4.1.11. For $u \in S_n$, we define the *length* of u as the integer $l(u) = \min\{l(v) \mid v \in \mathbb{T}_n \text{ and } \bar{v} = u\}$. A *representative of minimal length* of u in \mathbb{T}_n is an element $v \in \mathbb{T}_n$ such that $\bar{v} = u$ and $l(v) = l(u)$.

Theorem 4.4.1.12. *Let $u, v \in \mathbb{T}_n$. If u and v are two representative of minimal length of a same permutation σ , then $u \equiv v$, where \equiv is the congruence on \mathbb{T}_n generated by (4.4.2) and (4.4.3).*

Definition 4.4.1.13. Let \mathbf{C} be a cubical ω -category. For every $A \in \mathbf{C}_n$ and $\sigma \in S_n$, we say that A is σ -invertible if there exists a representative of minimal length u of σ such that A is u -invertible, and we define $\sigma \cdot A := u \cdot A$. By Lemma 4.4.1.6 and Theorem 4.4.1.12, this is independent from the choice of a minimal representative of σ .

Proposition 4.4.1.14. *The composites of the applications $\partial_i : \mathbb{T}_n \rightarrow \mathbb{T}_{n-1}$ with the projection $\mathbb{T}_{n-1} \twoheadrightarrow S_{n-1}$ are compatible with the relations (4.4.1) to (4.4.3). Hence, they induce applications $\partial_i : S_n \rightarrow S_{n-1}$, satisfying:*

$$\partial_i 1 = 1 \quad \partial_i \tau_j = \begin{cases} 1 & i = j, j + 1 \\ \tau_{j_i} & i \neq j, j + 1 \end{cases} \quad \partial_i(\sigma \cdot \tau) = \partial_i \sigma \cdot \partial_{i \cdot \sigma} \tau.$$

Specifically, for $1 \leq i \leq n$ and $\sigma \in S_n$, $\partial_i \sigma$ is the (necessarily unique) permutation satisfying for all $1 \leq j \leq n - 1$:

$$j \cdot \partial_i \sigma = (j^i \cdot \sigma)_{i \cdot \sigma} \tag{4.4.8}$$

Let \mathbf{C} be a cubical n -category, and $\sigma \in S_n$. A cell $A \in (\square \mathbf{C})_{n+1}$ is σ -invertible if and only if for all $j \leq n$, $A_{j \cdot \sigma}^\alpha$ is $\partial_j \sigma$ -invertible, and:

$$\partial_j^\alpha(\sigma \cdot A) = \partial_j \sigma \cdot \partial_{j \cdot \sigma}^\alpha A \tag{4.4.9}$$

Finally, let $\sigma \in S_n$. If $\sigma \neq 1$, then a cell $A \in \mathbf{C}_n$ is σ -invertible if and only if A is invertible and ∂A is σ -invertible.

Proof. For the first point we simply verify the equalities as needed (note in particular that the compatibility of ∂_i with Equation (4.4.2) is a consequence of Equation (4.4.7)).

The rest of the results is a consequence of Proposition 4.4.1.2, together with Lemma 4.4.1.4 and 4.4.1.5. \square

Remark 4.4.1.15. The operations ∂_i applied to a permutation σ correspond to deleting the i -th string in the string diagram representation of σ . For example, by definition we have:

$$\partial_1(\tau_1\tau_2) = (\partial_1\tau_1) \cdot (\partial_2\tau_2) = 1 \quad \partial_2(\tau_1\tau_2) = (\partial_2\tau_1) \cdot (\partial_1\tau_2) = \tau_1 \quad \partial_3(\tau_1\tau_2) = (\partial_3\tau_1) \cdot (\partial_3\tau_2) = \tau_1$$

Which can be diagrammatically represented as:

$$\partial_1(\text{string diagram}) = | \quad \partial_2(\text{string diagram}) = \text{string diagram} \quad \partial_3(\text{string diagram}) = \text{string diagram}$$

More generally, the relation $\partial_i(\sigma \cdot \tau) = \partial_i\sigma \cdot \partial_{i \cdot \sigma}\tau$ corresponds to the diagram:

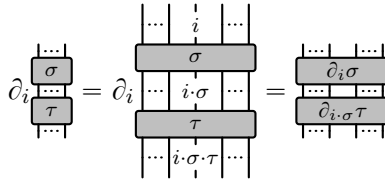

Finally, Equation (4.4.9) corresponds to the diagram:

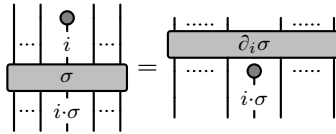

Lemma 4.4.1.16. Let \mathbf{C} be a cubical ω -category, and $A \in \mathbf{C}_n$. If $\epsilon_i A$ is σ -invertible, then A is $\partial_{i \cdot \sigma}$ - σ -invertible and:

$$\sigma \cdot \epsilon_i A = \epsilon_{i \cdot \sigma} (\partial_{i \cdot \sigma} \sigma \cdot A)$$

If $\Gamma_i^\alpha A$ is σ -invertible then A is also $\partial_{i \cdot \sigma}$ - σ -invertible and if $(i+1) \cdot \sigma^- = i \cdot \sigma^- + 1$ we have:

$$\sigma \cdot \Gamma_i^\alpha A = \Gamma_{i \cdot \sigma}^\alpha (\partial_{i \cdot \sigma} \sigma \cdot A)$$

Proof. If $\epsilon_i A$ is σ -invertible, then $A = \partial_i^- \epsilon_i A$ is $\partial_{i \cdot \sigma}$ - σ by Proposition 4.4.1.14.

To show the equality, we reason by induction on n . If $n = 0$ then $\sigma = 1$ and the result is verified. Otherwise, suppose $n > 0$. By Lemma 4.2.3.3, both sides of the equation are thin, and so they are equal if and only if their shells are equal. Note first that for $j = i \cdot \sigma^-$:

$$\partial_j^\alpha (\sigma \cdot \epsilon_i A) = \partial_j \sigma \cdot \partial_i^\alpha \epsilon_i A = \partial_j \sigma \cdot A = \partial_j^\alpha \epsilon_j (\partial_j \sigma \cdot A)$$

Now for $j \neq i \cdot \sigma^-$:

$$\partial_j^\alpha (\sigma \cdot \epsilon_i A) = \partial_j \sigma \cdot \partial_{j \cdot \sigma}^\alpha \epsilon_i A = \partial_j \sigma \cdot \epsilon_{i \cdot \sigma} \partial_{(j \cdot \sigma)_i}^\alpha A$$

Note that $\partial_j (\sigma \cdot \sigma^-) = \partial_j \sigma \cdot \partial_{j \cdot \sigma} \sigma^- = 1$, so $(\partial_j \sigma)^- = \partial_{j \cdot \sigma} \sigma^-$. So by proposition 4.4.1.14:

$$i \cdot \sigma \cdot (\partial_j \sigma)^- = (i_{j \cdot \sigma}^j \cdot \sigma^-)_{j \cdot \sigma \cdot \sigma^-} = (i \cdot \sigma^-)_j$$

So by induction hypothesis, we have $\partial_j^\alpha (\sigma \cdot \epsilon_i A) = \epsilon_{(i \cdot \sigma^-)_j} (\partial_{(i \cdot \sigma^-)_j} \partial_j \sigma \cdot \partial_{(j \cdot \sigma)_i}^\alpha A)$. On the other hand, note that $j_{i \cdot \sigma^-} \cdot \partial_{i \cdot \sigma^-} \sigma = (j_{i \cdot \sigma^-}^{i \cdot \sigma^-} \cdot \sigma)_{i \cdot \sigma^- \cdot \sigma} = (j \cdot \sigma)_i$. Applying this we get:

$$\partial_j^\alpha \epsilon_{i \cdot \sigma^-} (\partial_{i \cdot \sigma^-} \sigma \cdot A) = \epsilon_{(i \cdot \sigma^-)_j} \partial_{j_{i \cdot \sigma^-}}^\alpha (\partial_{i \cdot \sigma^-} \sigma \cdot A) = \epsilon_{(i \cdot \sigma^-)_j} (\partial_{j_{i \cdot \sigma^-}} \partial_{i \cdot \sigma^-} \sigma \cdot \partial_{(j \cdot \sigma)_i}^\alpha A).$$

Finally, it remains to show that $\partial_{j_{i,\sigma^-}} \partial_{i,\sigma^-} \sigma = \partial_{(i,\sigma^-)_j} \partial_j \sigma$. More generally, let us show that for any $i \neq j$, $\partial_{i_j} \partial_j \sigma = \partial_{j_i} \partial_i \sigma$. Indeed, for any k :

$$\partial_{i_j} \partial_j \sigma \cdot k = (((k^j)^{i_j} \cdot \sigma)_{i_j})_j = (k^{j,i} \cdot \sigma)_{i,j} \quad (4.4.10)$$

And this formula is symmetric in i and j by Lemma 4.1.1.3.

We now move on to the second equality. Once again if $\Gamma_i^\alpha A$ is σ -invertible, then $A = \partial_i^\alpha \Gamma_i^\alpha A$ is $\partial_{i,\sigma^-} \sigma$ -invertible by Proposition 4.4.1.14. We show the equality by induction on n . If $n = 1$, then the only permutation σ satisfying $(i+1) \cdot \sigma^- = i \cdot \sigma^- + 1$ is the identity, and the result is verified. Suppose now $n \geq 1$, and let $\sigma \in S_n$ such that $(i+1) \cdot \sigma^- = i \cdot \sigma^- + 1$. As previously, Lemma 4.2.3.3 show that both sides of the equation are thin, and so they are equal if and only if their shells are equal. Let us calculate their faces. Let $1 \leq j \leq n$ and $\beta = \pm$. We start by treating the case where $j = i \cdot \sigma^-$. For $\beta = \alpha$ we have:

$$\begin{aligned} \partial_j^\alpha (\sigma \cdot \Gamma_i^\alpha A) &= \partial_j \sigma \cdot \partial_{j,\sigma}^\alpha \Gamma_i^\alpha A = \partial_j \sigma \cdot \partial_i^\alpha \Gamma_i^\alpha A \\ &= \partial_j \sigma \cdot A = \partial_j^\alpha \Gamma_j^\alpha (\partial_j \sigma \cdot A) \end{aligned}$$

Now for $\beta = -\alpha$. Note first that $j \cdot \partial_j \sigma = (j^j \cdot \sigma)_i = ((j+1) \cdot \sigma)_i = (i+1)_i = i$ (we here use the hypothesis on σ). Therefore, $i \cdot (\partial_j \sigma)^- = j$, and:

$$\begin{aligned} \partial_j^{-\alpha} (\sigma \cdot \Gamma_i^\alpha A) &= \partial_j \sigma \cdot \partial_i^{-\alpha} \Gamma_i^\alpha A \\ &= \partial_j \sigma \cdot \epsilon_i \partial_i^{-\alpha} A \\ &= \epsilon_j (\partial_j \partial_j \sigma \cdot \partial_i^{-\alpha} A) \\ \partial_j^{-\alpha} \Gamma_j^\alpha (\partial_j \sigma \cdot A) &= \epsilon_j \partial_j^{-\alpha} (\partial_j \sigma \cdot A) \\ &= \epsilon_j (\partial_j \partial_j \sigma \cdot \partial_i^{-\alpha} A) \end{aligned}$$

The case where $j = i \cdot \sigma^- + 1$ is similar. We now study the general case where $\beta = \pm$ and $j \neq i \cdot \sigma^-, i \cdot \sigma^- + 1$:

$$\begin{aligned} \partial_j^\beta (\sigma \cdot \Gamma_i^\alpha A) &= \partial_j \sigma \cdot \partial_{j,\sigma}^\beta \Gamma_i^\alpha A \\ &= \partial_j \sigma \cdot \Gamma_{i_j,\sigma}^\alpha \partial_{(j,\sigma)_i}^\beta A \end{aligned}$$

$$\begin{aligned} \partial_j^\beta \Gamma_{i,\sigma^-}^\alpha (\partial_{i,\sigma^-} \sigma \cdot A) &= \Gamma_{(i,\sigma^-)_j}^\alpha \partial_{j_{i,\sigma^-}}^\beta (\partial_{i,\sigma^-} \sigma \cdot A) \\ &= \Gamma_{(i,\sigma^-)_j}^\alpha (\partial_{j_{i,\sigma^-}} \partial_{i,\sigma^-} \sigma \cdot \partial_{j_{i,\sigma^-} \cdot \partial_{i,\sigma^-} \sigma}^\beta A) \end{aligned}$$

To conclude using the induction hypothesis, we need to show that $j_{i,\sigma^-} \cdot \partial_{i,\sigma^-} \sigma = (j \cdot \sigma)_i$, and that $i_{j,\sigma} \cdot (\partial_j \sigma)^- = (i \cdot \sigma^-)_j$. And indeed we have:

$$\begin{aligned} j_{i,\sigma^-} \cdot \partial_{i,\sigma^-} \sigma &= (j_{i,\sigma^-}^{i,\sigma^-} \cdot \sigma)_{i,\sigma^-} = (j \cdot \sigma)_i \\ (i \cdot \sigma^-)_j \cdot \partial_j \sigma &= ((i \cdot \sigma^-)_j^j \cdot \sigma)_{j,\sigma} = i_{j,\sigma} \end{aligned}$$

□

Remark 4.4.1.17. Diagrammatically, the equations from Lemma 4.4.1.16 correspond to the following diagrams:

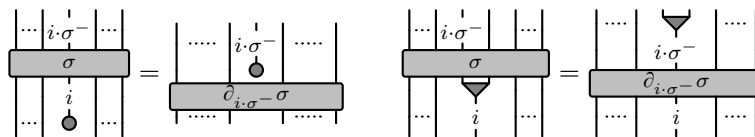

Remark 4.4.1.18. In this Section, we restricted ourselves to the T_i -inverses. However, all results previous can be adapted to also consider the R_i -inverses. The action of the symmetric groups are then extended into an action of the Hyperoctahedral groups BC_n , which are the full groups of permutations of the hypercubes. A presentation of the group BC_n is given by the generators R_i (for $1 \leq i \leq n$) and T_i (for $1 \leq i < n$), subject to the relations:

$$\begin{aligned} T_i T_i &= 1 & T_i T_{i+1} T_i &= T_{i+1} T_i T_{i+1} & T_j T_i &= T_j T_i & |i - j| \geq 2 \\ R_i R_i &= 1 & R_i R_j &= R_j R_i & & i \neq j \\ T_i R_i &= R_{i+1} T_i & T_i R_{i+1} &= R_i T_i & T_i R_j &= R_j T_i & j \neq i, i + 1 \end{aligned}$$

In particular the groups BC_n are Coxeter groups and they hence verify an analogue to Theorem 4.4.1.12, often called Matsumoto's Theorem [64].

4.4.2 Transforms between cubical ω -categories

Let \mathcal{C} and \mathcal{D} be two categories, and $F, G : \mathcal{C} \rightarrow \mathcal{D}$ be functors. Recall that a natural transformation η from F to G is given by an application $\eta : \mathcal{C}_0 \rightarrow \mathcal{D}_1$ such that, for all $x \in \mathcal{C}_0$, $s(\eta_x) = F(x)$, $t(\eta_x) = G(x)$, and for all $f : x \rightarrow y \in \mathcal{C}_1$ the following diagram commutes:

$$\begin{array}{ccc} F(x) & \xrightarrow{F(f)} & F(y) \\ \eta_x \downarrow & & \downarrow \eta_y \\ G(x) & \xrightarrow{G(f)} & G(y) \end{array} \quad (4.4.11)$$

Natural transformations compose, and so for any categories \mathcal{C} and \mathcal{D} there is a category $\mathbf{Cat}(\mathcal{C}, \mathcal{D})$.

If \mathcal{C} and \mathcal{D} are two globular 2-categories, and $F, G : \mathcal{C} \rightarrow \mathcal{D}$ are two functors, then there are multiple ways to extend the notion of natural transformation. A *lax natural transformation* from F to G consists in applications $\eta : \mathcal{C}_0 \rightarrow \mathcal{D}_1$ and $\eta : \mathcal{C}_1 \rightarrow \mathcal{D}_2$, satisfying some compatibility conditions. In particular, for $f : x \rightarrow y \in \mathcal{C}_1$, the 2-cell $\eta_f \in \mathcal{D}_2$ is required to have the following source and target:

$$\begin{array}{ccc} F(x) & \xrightarrow{F(f)} & F(y) \\ \eta_x \downarrow & \eta_f \begin{array}{c} \rightrightarrows \\ \lrcorner \end{array} & \downarrow \eta_y \\ G(x) & \xrightarrow{G(f)} & G(y) \end{array}$$

An *oplax natural transformation* requires the 2-cell η_f to be in the opposite direction. This leads to two different notions of the 2-category of functors between \mathcal{C} and \mathcal{D} , where objects are functors from \mathcal{C} to \mathcal{D} , 1-cells are lax (resp. oplax) natural transformations, and 2-cells are modifications. Modifications consist of an application $\mathcal{C}_0 \rightarrow \mathcal{D}_2$ satisfying some compatibility conditions. Notice that, if η is a lax natural transformation and η_f is invertible for all $f \in \mathcal{C}_1$, then replacing η_f by its inverse yields an oplax natural transformation (and reciprocally when reversing the role of lax and oplax natural transformation). Such natural transformations are called *pseudo*.

More generally, if \mathcal{C} and \mathcal{D} are ω -categories, then for any $k \geq 0$ there are notions of lax and oplax k -transforms between them (following terminology by Crans [25]), consisting of applications

$\mathcal{C}_n \rightarrow \mathcal{D}_{n+k}$, for all $n \geq 0$. In particular, 0-transfers correspond to functors, and lax (resp. oplax) 1-transfers to lax (resp. oplax) natural transformations.

Similar constructions can be made in cubical ω -categories, and are recalled in Definition 4.4.2.1. This definition uses the notion of Crans-Grey tensor product between cubical ω -categories. One benefit of working in cubical categories is that this tensor product has a very natural expression in this setting, and so we are able to make explicit the conditions that transfers between cubical ω -categories have to satisfy. Next we define the two notion of pseudo transfer: one for lax and one for oplax transfer, using the notion of σ -invertibility defined in Section 4.4.1. In Proposition 4.4.2.4, we give an alternative characterisation of pseudo transfers. Lastly we prove that the notions of pseudo lax and oplax transfers coincide in Proposition 4.4.2.6.

Definition 4.4.2.1. We exhibited in Section 4.1 a structure of *cubical ω -category* object in $\omega\text{-}\mathbf{Cat}^{\text{op}}$ on the family $n\text{-}\blacksquare^{\mathbf{G}}$. Applying the functor λ , we obtain a structure of cubical ω -category object in $\omega\text{-}\mathbf{CubCat}^{\text{op}}$ of the family $n\text{-}\blacksquare^{\mathbf{C}} := \lambda(n\text{-}\blacksquare^{\mathbf{G}})$.

Consequently, if \mathbf{C} and \mathbf{D} are cubical ω -categories, then both the families (of sets) $\mathbf{Lax}(\mathbf{C}, \mathbf{D})_n = \omega\text{-}\mathbf{CubCat}(n\text{-}\blacksquare^{\mathbf{C}} \otimes \mathbf{C}, \mathbf{D})$ and $\mathbf{OpLax}(\mathbf{C}, \mathbf{D})_n = \omega\text{-}\mathbf{CubCat}(\mathbf{C} \otimes n\text{-}\blacksquare^{\mathbf{C}}, \mathbf{D})$ come equipped with cubical ω -category structures (where we denote by \otimes the monoidal product on $\omega\text{-}\mathbf{CubCat}$ as defined in [2]).

We call an element $F \in \mathbf{Lax}(\mathbf{C}, \mathbf{D})_n$ (resp. $F \in \mathbf{OpLax}(\mathbf{C}, \mathbf{D})_n$) a *lax n -transfer* (resp. an *oplax n -transfer*) from \mathbf{C} to \mathbf{D} . Unfolding the definition of the monoidal product on $\omega\text{-}\mathbf{CubCat}$ as defined in [2], Section 10, a lax p -transfer (resp. oplax p -transfer) is a family of applications $F_n : \mathbf{C}_n \rightarrow \mathbf{D}_{n+p}$ satisfying the equations (4.4.12) to (4.4.15) (resp. (4.4.16) to (4.4.19)).

$$\partial_{p+i}^\alpha F_n(A) = F_{n-1}(\partial_i^\alpha A) \quad (4.4.12) \quad \partial_i^\alpha F_n(A) = F_{n-1}(\partial_i^\alpha A) \quad (4.4.16)$$

$$F_n(\epsilon_i A) = \epsilon_{p+i} F_{n-1}(A) \quad (4.4.13) \quad F_n(\epsilon_i A) = \epsilon_i F_{n-1}(A) \quad (4.4.17)$$

$$F_n(\Gamma_i^\alpha A) = \Gamma_{p+i}^\alpha F_{n-1}(A) \quad (4.4.14) \quad F_n(\Gamma_i^\alpha A) = \Gamma_i^\alpha F_{n-1}(A) \quad (4.4.18)$$

$$F_n(A \star_i B) = F_n(A) \star_{p+i} F_n(B) \quad (4.4.15) \quad F_n(A \star_i B) = F_n(A) \star_i F_n(B) \quad (4.4.19)$$

Moreover, the cubical ω -category structure on $\mathbf{Lax}(\mathbf{C}, \mathbf{D})$ (resp. on $\mathbf{OpLax}(\mathbf{C}, \mathbf{D})$) is given by the equations (4.4.20) to (4.4.23) (resp. (4.4.24) to (4.4.27)).

$$(\partial_i^\alpha F)_n(A) = \partial_i^\alpha (F_n(A)) \quad (4.4.20) \quad (\partial_i^\alpha F)_n(A) = \partial_{n+i}^\alpha (F_n(A)) \quad (4.4.24)$$

$$(\epsilon_i F)_n(A) = \epsilon_i (F_n(A)) \quad (4.4.21) \quad (\epsilon_i F)_n(A) = \epsilon_{n+i} (F_n(A)) \quad (4.4.25)$$

$$(\Gamma_i^\alpha F)_n(A) = \Gamma_i^\alpha (F_n(A)) \quad (4.4.22) \quad (\Gamma_i^\alpha F)_n(A) = \Gamma_{n+i}^\alpha (F_n(A)) \quad (4.4.26)$$

$$(F \star_i G)_n(A) = F_n(A) \star_i G_n(A) \quad (4.4.23) \quad (F \star_i G)_n(A) = F_n(A) \star_{n+i} G_n(A) \quad (4.4.27)$$

The following Proposition is a consequence of [2], Section 10.

Proposition 4.4.2.2. *Let \mathbf{C} be a cubical ω -category. The functors $(_ \otimes \mathbf{C})$ and $(\mathbf{C} \otimes _)$ are respectively left-adjoint to the functors $\mathbf{Lax}(\mathbf{C}, _)$ and $\mathbf{OpLax}(\mathbf{C}, _)$. This implies that $\omega\text{-}\mathbf{CubCat}$ is a biclosed monoidal category.*

Definition 4.4.2.3. Let $n, m \geq 0$ be integers. We denote by $\rho_{n,m} \in S_{n+m}$ the following permutations:

$$i \cdot \rho_{n,m} := \begin{cases} i+n & i \leq n \\ i-n & i > n \end{cases}$$

Let \mathbf{C} and \mathbf{D} be cubical ω -categories. We say that a lax p -transfor $F : \mathbf{C} \rightarrow \mathbf{D}$ is *pseudo* if for all $A \in \mathbf{C}_n$, $F(A)$ is $\rho_{n,p}$ -invertible. We say that an oplax p -transfor $F : \mathbf{C} \rightarrow \mathbf{D}$ is *pseudo* if for all $A \in \mathbf{C}_n$, $F(A)$ is $\rho_{p,n}$ -invertible.

Proposition 4.4.2.4. *Let \mathbf{C} and \mathbf{D} be cubical ω -categories, and $F : \mathbf{C} \rightarrow \mathbf{D}$ a lax p -transfor (resp. an oplax p -transfor). Then F is pseudo if and only if:*

- Either $p = 0$,
- Or $p > 0$, for all $n > 0$ and all $A \in \mathbf{C}_n$, $F(A)$ is invertible, and for all $1 \leq i \leq p$, $\partial_i^\alpha F$ is pseudo.

Moreover, if F is pseudo, then so are $\Gamma_i^\alpha F$ ($1 \leq i \leq p$), $\epsilon_i F$ ($1 \leq i \leq p+1$) and, if G is a pseudo lax p -transfor (resp. pseudo oplax p -transfor) then $F \star_i G$ (if defined) is also pseudo, for $1 \leq i \leq p$.

Proof. Let us prove the result for pseudo lax p -transfors, the case of pseudo oplax p -transfors being similar. If $p = 0$, then for all n , $\rho_{n,p} = 1$. Since any cell in \mathbf{D} is 1-invertible, any lax 0-transfor is pseudo.

Suppose now $p > 0$. Let $F \in \mathbf{Lax}(\mathbf{C}, \mathbf{D})_p$, and suppose F is pseudo. Let $n > 0$ and $A \in \mathbf{C}_n$. Then $\rho_{n,p} \neq 1$, and by Proposition 4.4.1.14, $F_n(A)$ is invertible. Moreover, for $1 \leq i \leq p$, $(\partial_i^\alpha F)_n(A) = \partial_{(p+i)\cdot\rho_{n,p}}^\alpha(F_n(A))$ is $\partial_{p+i\rho_{n,p}}$ -invertible. Since $\partial_{p+i\rho_{n,p}} = \rho_{n,p-1}$, we just proved that for all $A \in \mathbf{C}_n$, $(\partial_i^\alpha F)_n(A)$ is $\rho_{n,p-1}$ -invertible. So $\partial_i^\alpha F$ is pseudo.

Reciprocally, suppose that for all $n > 0$, $F_n(A)$ is invertible, and for all $1 \leq i \leq p$, $\partial_i^\alpha F$ is pseudo. We reason by induction on n to show that for all $A \in \mathbf{C}_n$, $F_n(A)$ is $\rho_{n,p}$ -invertible. If $n = 0$, $\rho_{n,p} = 1$ and $F_n(A)$ is $\rho_{n,p}$ -invertible. If $n \geq 1$, then $F(A)$ is invertible and for all $1 \leq i \leq p$, $\partial_{(i+n)\cdot\rho_{n,p}}^\alpha(F_n(A)) = (\partial_i^\alpha F)(A)$ is $\rho_{n,p-1}$ -invertible. And for all $1 \leq i \leq n$, $\partial_{i\cdot\rho_{n,p}}^\alpha(F_n(A)) = F_{n-1}(\partial_i^\alpha F)$ is $\rho_{n-1,p}$ -invertible by induction. In conclusion, $F_n(A)$ is invertible, and for all $1 \leq i \leq p+n$, $\partial_i^\alpha(F_n(A))$ is $\partial_i\rho_{n,p}$ -invertible. By Proposition 4.4.1.14, $F_n(A)$ is $\rho_{n,p}$ -invertible.

We reason by induction on p to show that, for any pseudo lax p -transfor. F , $\epsilon_i F$ and $\Gamma_i^\alpha F$ are pseudo. Let $A \in \mathbf{C}_n$. By equations (4.4.13) and (4.4.14), $(\epsilon_i F)(A)$ and $(\Gamma_i^\alpha F)(A)$ are thin cells, and so in particular are invertible. Moreover, the cubical ω -category structure on $\mathbf{Lax}(\mathbf{C}, \mathbf{D})$ show that for all j , we have:

$$\partial_i^\alpha \epsilon_j F = \begin{cases} \epsilon_j \partial_{ij}^\alpha F & i \neq j \\ F & i = j \end{cases} \quad \partial_i^\alpha \Gamma_j^\beta F = \begin{cases} \Gamma_{ji}^\beta \partial_{ij}^\alpha F & i \neq j, j+1 \\ F & i = j, j+1 \text{ and } \alpha = \beta \\ \epsilon_j \partial_j^\alpha F & i = j, j+1 \text{ and } \alpha = -\beta \end{cases}$$

Using what we proved previously, $\partial_k^\alpha F$ is pseudo for all k , so by induction, $\partial_j^\alpha \epsilon_i F$ and $\partial_j^\beta \Gamma_i^\alpha F$ are always pseudo. Applying the criterion that we proved previously for a p -transfor to be pseudo, $\epsilon_i F$ and $\Gamma_i^\alpha F$ are pseudo.

Finally, we reason by induction on p to show that for any two pseudo lax p -transfors F and G , $F \star_i G$ is pseudo (if it is defined). Since any lax 0-transfor is pseudo, it is true if $p = 0$. Take now $p > 0$, and $A \in \mathbf{C}_n$, for some $n > 0$. Then $F(A)$ and $G(A)$ are invertible, and so

is $(F \star_i G)_n(A) = F_n(A) \star_i G_n(A)$ by Lemma 4.2.2.3. Moreover, using the cubical ω -category structure on $\mathbf{Lax}(\mathbf{C}, \mathbf{D})$, we have:

$$\partial_i^\alpha(F \star_j G) = \begin{cases} \partial_i^\alpha F \star_{j_i} \partial_i^\alpha G & i \neq j \\ \partial_i^- F & i = j \text{ and } \alpha = - \\ \partial_i^+ G & i = j \text{ and } \alpha = + \end{cases}$$

So by the induction hypothesis, $\partial_j^\alpha(F \star_i G)$ is pseudo for all j . Therefore, $F \star_i G$ is pseudo. \square

Definition 4.4.2.5. Let \mathbf{C} and \mathbf{D} be cubical ω -categories. We denote by $\mathbf{PsLax}(\mathbf{C}, \mathbf{D})$ (resp. $\mathbf{PsOpLax}(\mathbf{C}, \mathbf{D})$) the pseudo lax transforms (resp. the pseudo oplax transforms) from \mathbf{C} to \mathbf{D} . By Proposition 4.4.2.4, $\mathbf{PsLax}(\mathbf{C}, \mathbf{D})$ and $\mathbf{PsOpLax}(\mathbf{C}, \mathbf{D})$ are cubical ω -categories.

Proposition 4.4.2.6. For all cubical ω -categories \mathbf{C} and \mathbf{D} , the cubical ω -categories $\mathbf{PsLax}(\mathbf{C}, \mathbf{D})$ and $\mathbf{PsOpLax}(\mathbf{C}, \mathbf{D})$ are isomorphic.

Proof. Let $F \in \mathbf{PsLax}(\mathbf{C}, \mathbf{D})$, and define applications $G_n : \mathbf{C}_n \rightarrow \mathbf{D}_{n+p}$ as: $G_n(A) = \rho_{n,p} \cdot F_n(A)$. Let us show that G is an oplax p -transform (using formulas from Lemma 4.4.1.16):

$$\begin{aligned} \partial_i^\alpha G_n(A) &= \partial_i^\alpha(\rho_{n,p} \cdot F_n(A)) = \partial_i \rho_{n,p} \cdot \partial_{i, \rho_{n,p}}^\alpha F_n(A) \\ &= \rho_{n-1,p} \cdot \partial_{i+p} F_n(A) = \rho_{n-1,p} \cdot F_{n-1}(\partial_i^\alpha(A)) = G_{n-1}(\partial_i^\alpha(A)) \end{aligned}$$

$$\begin{aligned} G_n(\epsilon_i A) &= \rho_{n,p} \cdot F_n(\epsilon_i A) = \rho_{n,p} \cdot \epsilon_{p+i} F_{n-1}(A) \\ &= \epsilon_{(p+i) \cdot \rho_{p,n}} (\partial_{(p+i) \cdot \rho_{p,n}} \rho_{n,p} \cdot F_{n-1}(A)) \\ &= \epsilon_i (\partial_i \rho_{n,p} \cdot F_{n-1}(A)) = \epsilon_i (\rho_{n-1,p} \cdot F_{n-1}(A)) = \epsilon_i G_{n-1}(A) \end{aligned}$$

$$\begin{aligned} G_n(\Gamma_i^\alpha A) &= \rho_{n,p} \cdot F_n(\Gamma_i^\alpha A) = \rho_{n,p} \cdot \Gamma_{p+i}^\alpha F_{n-1}(A) \\ &= \Gamma_{(p+i) \cdot \rho_{p,n}}^\alpha (\partial_{(p+i) \cdot \rho_{p,n}} \rho_{n,p} \cdot F_{n-1}(A)) \\ &= \Gamma_i^\alpha (\partial_i \rho_{n,p} \cdot F_{n-1}(A)) = \Gamma_i^\alpha (\rho_{n-1,p} \cdot F_{n-1}(A)) = \Gamma_i^\alpha G_{n-1}(A) \end{aligned}$$

$$\begin{aligned} G_n(A \star_i B) &= \rho_{n,p} \cdot F_n(A \star_i B) = \rho_{n,p} \cdot (F_n(A) \star_{p+i} F_n(B)) \\ &= (\rho_{n,p} \cdot F_n(A)) \star_{(p+i) \cdot \rho_{p,n}} (\rho_{n,p} \cdot F_n(B)) = G_n(A) \star_i G_n(B) \end{aligned}$$

We denote by $\mathbf{P}(F)$ this oplax p -transform. Moreover, for $A \in \mathbf{C}_n$ $\rho \cdot F(A) = \rho_{n,p} \cdot F(A)$ is $\rho_{p,n}$ -invertible (with $\rho_{p,n}$ -inverse A). So $\mathbf{P}(F)$ is actually pseudo. Let us show that \mathbf{P} is functorial. Let $F \in \mathbf{PsLax}(\mathbf{C}, \mathbf{D})_p$:

$$\begin{aligned} (\partial_i^\alpha(\mathbf{P}(F)))_n(A) &= \partial_{n+i}^\alpha((\mathbf{P}(F))_n(A)) = \partial_{n+i}^\alpha(\rho_{n,p} \cdot F(A)) \\ &= \partial_{n+i} \rho_{n,p} \cdot \partial_{(n+i) \cdot \rho_{n,p}}^\alpha F(A) \\ &= \rho_{n,p-1} \cdot \partial_i^\alpha F(A) = \mathbf{P}(\partial_i^\alpha F)(A) \end{aligned}$$

$$\begin{aligned} (\mathbf{P}(\Gamma_i^\alpha F))_n(A) &= \rho_{n,p} \cdot ((\Gamma_i^\alpha F)_n(A)) = \rho_{n,p} \cdot \Gamma_i^\alpha(F_n(A)) \\ &= \Gamma_{i \cdot \rho_{p,n}}^\alpha (\partial_{i \cdot \rho_{p,n}} \rho_{n,p} \cdot F_n(A)) \\ &= \Gamma_{n+i}^\alpha (\partial_{p+i} \rho_{n,p} \cdot F_n(A)) = \Gamma_{n+i}^\alpha (\rho_{n,p-1} \cdot F_n(A)) = (\Gamma_i^\alpha(\mathbf{P}(F)))_n(A) \end{aligned}$$

$$\begin{aligned}
(\mathbf{P}(\epsilon_i F))_n(A) &= \rho_{n,p} \cdot ((\epsilon_i F)_n(A)) = \rho_{n,p} \cdot \epsilon_i(F_n(A)) \\
&= \epsilon_{i \cdot \rho_{p,n}}(\partial_{i \cdot \rho_{p,n}} \rho_{n,p} \cdot F_n(A)) \\
&= \epsilon_{n+i}(\partial_{p+i} \rho_{n,p} \cdot F_n(A)) = \epsilon_{n+i}(\rho_{n,p-1} \cdot F_n(A)) = (\epsilon_i(\mathbf{P}(F)))_n(A)
\end{aligned}$$

$$\begin{aligned}
(\mathbf{P}(F \star_i G))_n(A) &= \rho_{n,p} \cdot ((F \star_i G)_n(A)) = \rho_{n,p} \cdot (F_n(A) \star_i G_n(A)) \\
&= (\rho_{n,p} \cdot F_n(A)) \star_{i \cdot \rho_{p,n}} (\rho_{n,p} \cdot G_n(A)) \\
&= \mathbf{P}(F)_n(A) \star_i \mathbf{P}(G)_n(A) = (\mathbf{P}(F) \star_i \mathbf{P}(G))_n(A)
\end{aligned}$$

So \mathbf{P} is a functor from $\mathbf{PsLax}(\mathbf{C}, \mathbf{D})$ to $\mathbf{PsOpLax}(\mathbf{C}, \mathbf{D})$. Reciprocally, if F is a pseudo oplax p -transfor, we define a family of applications $\mathbf{R}(F)_n : \mathbf{C}_n \rightarrow \mathbf{D}_{n+p}$ by setting $\mathbf{R}(F)_n(A) = \rho_{p,n} \cdot F_n(A)$. As we did for \mathbf{P} , we show that \mathbf{R} induces a functor from $\mathbf{PsOpLax}(\mathbf{C}, \mathbf{D})$ to $\mathbf{PsLax}(\mathbf{C}, \mathbf{D})$. Finally, since $\rho_{p,n} \cdot \rho_{n,p} = 1$, \mathbf{P} and \mathbf{R} are inverses of each other, and $\mathbf{PsLax}(\mathbf{C}, \mathbf{D})$ is isomorphic to $\mathbf{PsOpLax}(\mathbf{C}, \mathbf{D})$. \square

Chapter 5

Resolution of monoids

Organisation

The goal of this chapter is to reformulate higher-dimensional rewriting in the framework of cubical categories, using the notion of cubical (ω, p) -category that we described in the last chapter. Section 5.1 contains some preliminary materials before we are able to express our main result (Theorem 5.1.3.8). We reserve the proof of Theorem 5.1.3.8 for Section 5.2.

Finally Section 2.3, we look for applications of Theorem 5.1.3.8. In particular, we give an explicit description of the reduced standard presentation of a monoid, and we construct the Squier resolution of a monoid presented by a convergent presentation, a result similar to the one from [40].

5.1 Resolutions of monoids by Gray polygraphs

The goal of this Section is to express our Extended Detection Theorem. In Section 5.1.1, we start by giving the definition of Gray polygraphs. Section 5.1.2 contains the proof of the central fact that Gray monoids are also free ω -categories. Finally, in Section 5.1.3, we study the structure of local branchings and prove that they form a simplicial monoid. We finally state our Extended Detection Theorem.

5.1.1 Gray polygraphs

In order to define a notion of Gray polygraph associated to Gray categories, we make use of a result of Garner [28]. In order to do that we need to prove that Gray monoids are monadic over pre-cubical sets. The adjunction between Gray monoids and cubical sets is the composite of two monadic adjunctions (factorising through cubical ω -groupoids). However, as is well-known a composite of monadic adjunctions is not necessarily monadic. Still, in our case we are able to use a criterion from [27] to conclude. First, let us start by recalling the following classical fact about monadic functors (see for example [60]):

Proposition 5.1.1.1. *Let (T, μ, η) be a monad on a category \mathcal{C} , and U, F the adjunction it induces between \mathcal{C} and \mathcal{C}^T . The functor U strictly creates coequalizers of U -split pairs.*

In other words, for any $f, g : (A, \alpha) \rightarrow (B, \beta)$ in \mathcal{C}^T , if there exists C in \mathcal{C} and $h : B \rightarrow C$ in \mathcal{C} such that

$$A \begin{array}{c} \xrightarrow{f} \\ \xrightarrow{g} \end{array} B \xrightarrow{h} C$$

is a split coequalizer in \mathcal{C} , then there exists a unique $\gamma : TC \rightarrow C$ such that (C, γ) is a T -algebra and the diagram

$$(A, \alpha) \begin{array}{c} \xrightarrow{f} \\ \xrightarrow{g} \end{array} (B, \beta) \xrightarrow{h} (C, \gamma)$$

is a coequaliser in \mathcal{C}^T .

Moreover, γ is the only morphism making the following square commute:

$$\begin{array}{ccc} TB & \xrightarrow{Th} & TC \\ \beta \downarrow & & \downarrow \gamma \\ B & \xrightarrow{h} & C \end{array}$$

The following Proposition shows that any algebra for a monad can be recovered as a reflexive coequaliser of free algebras.

Proposition 5.1.1.2. *Let (T, μ, η) be a monad on a category \mathcal{C} , and (A, h) be a T -algebra. The following is a reflexive coequaliser in \mathcal{C}^T :*

$$(TTA, \mu_{TA}) \begin{array}{c} \xrightarrow{Th} \\ \xrightarrow{\mu_A} \end{array} (TA, \mu_A) \xrightarrow{h} (A, h)$$

Proof. Note first that the diagram

$$TTA \begin{array}{c} \xrightarrow{Th} \\ \xrightarrow{\mu_A} \end{array} TA \xrightarrow{h} A$$

is an equaliser in \mathcal{C} , which is split by the morphisms $T\eta_A$ and η_A . Moreover, the following square commutes:

$$\begin{array}{ccc} TTA & \xrightarrow{Th} & TA \\ \mu_A \downarrow & & \downarrow h \\ TA & \xrightarrow{h} & TA \end{array}$$

Thus, the fact that it is a coequaliser follows from Proposition 5.1.1.1. To show that it is also reflexive, let us look at the morphism $T\eta_A : TTA \rightarrow TA$. By hypothesis $Th \circ T\eta_A = 1_{TA}$ and $\mu_A \circ T\eta_A = 1_{TA}$. So all we have to do is check that $T\eta_A : (TTA, \mu_{TA}) \rightarrow (TA, \mu_A)$ is a morphism of T -algebras. Indeed, the following diagram commutes by naturality of μ :

$$\begin{array}{ccc} TTA & \xrightarrow{TT\eta_A} & TTTA \\ \mu_A \downarrow & & \downarrow \mu_{TA} \\ TA & \xrightarrow{T\eta_A} & TTA \end{array}$$

□

The following Proposition was written (incorrectly) in [27]. We reproduce here the corrected Proposition and proof from the Errata.

Proposition 5.1.1.3. *Suppose we have two adjunctions:*

$$\mathcal{C} \begin{array}{c} \xleftarrow{F_2} \\ \xleftarrow{\perp} \\ \xrightarrow{U_2} \end{array} \mathcal{D} \begin{array}{c} \xleftarrow{F_1} \\ \xleftarrow{\perp} \\ \xrightarrow{U_1} \end{array} \mathcal{E}$$

We denote respectively by T_1 and T_2 the monads $U_1 \circ F_1$ and $U_2 \circ F_2$.

Suppose \mathcal{D} is the category of algebras of T_1 and \mathcal{E} is the category of algebras of T_2 . If T_1 preserves reflexive coequalisers in \mathcal{D} , then \mathcal{C} is isomorphic to the category of algebras of the monad $T := U_1 \circ U_2 \circ F_2 \circ F_1$.

Proof. Recall first that, for any monad (T, μ, η) , and any T -algebra (A, h) , h induces a morphism of T -algebras $h^* : (TA, \mu_A) \rightarrow (A, h)$, as shown by the commutation of the following square:

$$\begin{array}{ccc} TTA & \xrightarrow{\mu_A} & TA \\ Th \downarrow & & \downarrow h \\ TA & \xrightarrow{h} & A \end{array}$$

Suppose now (A, h_1, h_2) is a T_2 -algebra, where (A, h_1) is a T_1 -algebra. Then the following morphism equips A with a structure of T -algebra:

$$TA = U_1 T_2 F_1 A = U_1 T_2 (T_1 A, \mu_A) \xrightarrow{U_1 T_2 h_1^*} U_1 T_2 (A, h_1) \xrightarrow{U_1 h_2} U_1 (A, h_1) = A$$

This construction induces a functor from T_2 -algebras to T -algebras.

Let us now fix a T -algebra (A, h) and let us define h_1 and h_2 making (A, h_1, h_2) a T_2 -algebra. First we define h_1 as the following composite:

$$T_1 A = U_1 F_1 A \xrightarrow{U_1 \eta_{F_1 A}^2} U_1 T_2 F_1 A = TA \xrightarrow{h} A$$

Moreover, the following diagram is a reflexive coequaliser in of T_1 -algebras by Proposition 5.1.1.2:

$$(T_1 T_1 A, \mu_{T_1 A}^1) \begin{array}{c} \xrightarrow{T_1 h_1} \\ \xrightarrow{\mu_{A_1}^1} \end{array} (T_1 A, \mu_A^1) \xrightarrow{h_1} (A, h_1).$$

By hypothesis T_2 preserves reflexive coequalisers and so the following is an equaliser of T_1 -algebras:

$$T_2(T_1 T_1 A, \mu_{T_1 A}^1) \begin{array}{c} \xrightarrow{T_2 T_1 h_1} \\ \xrightarrow{T_2 \mu_{A_1}^1} \end{array} T_2(T_1 A, \mu_A^1) \xrightarrow{T_2 h_1} T_2(A, h_1).$$

Let us spell out explicitly $T_2(T_1 A, \mu_A^1)$. Compositing with U_1 , we get that it is of the form (TA, h'_1) for some morphism $h'_1 : T_1 TA \rightarrow TA$. Let us $\epsilon^1 : F_1 U_1 \rightarrow Id_{\mathcal{D}}$ be the counit of the adjunction F_1, U_1 . First the fact that $\epsilon_{T_2 F_1 A}^1$ is a morphism of T_1 -algebra from $F_1 U_1 T_2 F_1 A = (T_1 TA, \mu_{TA}^1)$ to $T_2 F_1 A = (TA, h'_1)$ gives us:

$$\begin{array}{ccc} T_1 T_1 TA & \xrightarrow{T_1 U_1 \epsilon_{T_2 F_1 A}^1} & T_1 TA \\ \mu_{TA}^1 \downarrow & & \downarrow h'_1 \\ T_1 TA & \xrightarrow{U_1 \epsilon_{T_2 F_1 A}^1} & TA \end{array}$$

Precomposing this square with $T_1 \eta_{TA}^1$ gives us the equality $h'_1 = U_1 \epsilon_{T_2 F_1 A}^1$. Notice that we can express $U_1 \epsilon_{T_2 F_1 A}^1$ as $\mu_A \circ U_1 \eta_{F_1 TA}^2$. Indeed, we have by definition of μ_A :

$$\begin{aligned} \mu_A \circ U_1 \eta_{F_1 TA}^2 &= U_1 \mu_{F_1 A}^2 \circ U_1 T_2 \epsilon_{T_2 F_1 A}^1 \circ U_1 \eta_{F_1 TA}^2 \\ &= U_1 \mu_{F_1 A}^2 \circ U_1 \eta_{T_2 F_1 A}^2 \circ U_1 \epsilon_{T_2 F_1 A}^1 \\ &= U_1 \epsilon_{T_2 F_1 A}^1. \end{aligned}$$

So we finally get $T_2F_1A = (TA, \mu_A \circ U_1\eta_{F_1TA}^2)$.

Let us now show that $h : TA \rightarrow A$ induces a morphism of T_1 -algebras: $T_2F_1A \rightarrow (A, h_1)$. Using the definition of h_1 , this amounts to the commutation of the following diagram, where the top square commutes by naturality of η^2 , and the bottom square because h is T -algebra structure on A .

$$\begin{array}{ccc} T_1TA & \xrightarrow{T_1h} & T_1A \\ U_1\eta_{F_1TA}^2 \downarrow & & \downarrow U_1\eta_{F_1A}^2 \\ TTA & \xrightarrow{Th} & TA \\ \mu_A \downarrow & & \downarrow h \\ TA & \xrightarrow{h} & A \end{array}$$

Let us now show that there is a fork in T_1 -algebras:

$$T_2(T_1T_1A, \mu_{T_1A}^1) \xrightarrow[T_2\mu_A^1]{T_2T_1h_1} T_2(T_1A, \mu_A^1) \xrightarrow{h} (A, h_1).$$

Since $T_2(T_1T_1A, \mu_{T_1A}^1) = T_2F_1T_1A = (TT_1A, U_1\epsilon_{T_2F_1A}^1)$, this amounts to the commutation of the following square:

$$\begin{array}{ccc} TT_1A & \xrightarrow{Th_1} & TA \\ U_1T_2\mu_A^1 \downarrow & & \downarrow h \\ TA & \xrightarrow{h} & A \end{array}$$

This square commutes because of the following equalities:

$$\begin{aligned} h \circ Th_1 &= h \circ Th \circ TU_1\eta_{F_1A}^2 = h \circ \mu_A \circ TU_1\eta_{F_1A}^2 \\ &= h \circ U_1\mu_{F_1A}^2 \circ U_1T_2\epsilon_{T_2F_1A}^1 \circ TU_1\eta_{F_1A}^2 \\ &= h \circ U_1\mu_{F_1A}^2 \circ U_1T_2\eta_{F_1A}^2 \circ U_1T_2\epsilon_{F_1A}^1 \\ &= h \circ U_1T_2\epsilon_{F_1A}^1 = h \circ U_1T_2\mu_A^1. \end{aligned}$$

By universal property of the coequalizer, we thereby get a morphism of T_1 -algebras $h_2 : T_2(A, h_1) \rightarrow (A, h_1)$, which equips (A, h_1) with the structure of a T_2 -algebra. \square

In our case, the monad T_1 is the free monoid monad. We show more generally in Proposition 5.1.1.5 that whenever T_1 is a free monoid monad over a biclosed monoidal category, T_1 satisfies the hypothesis of Proposition 5.1.1.3. First let us recall a classical result about biclosed monoidal categories.

Lemma 5.1.1.4. *A biclosed product preserves reflexive coequalisers in both variables simultaneously.*

Proof. Suppose we have the following reflexive coequalisers, for $i = 0, 1$:

$$\begin{array}{ccccc} & & r_i & & \\ & \curvearrowright & & \curvearrowleft & \\ A_i & \xrightarrow{f_i} & B_i & \xrightarrow{h_i} & C_i \\ & \xrightarrow{y_i} & & & \end{array}$$

We are going to show that the following is also a coequaliser:

$$A_0 \otimes A_1 \begin{array}{c} \xrightarrow{f_0 \otimes f_1} \\ \xrightarrow{g_0 \otimes g_1} \end{array} B_0 \otimes B_1 \xrightarrow{h_0 \otimes h_1} C_0 \otimes C_1$$

Suppose given $i : B_0 \otimes B_1 \rightarrow D$ such that $i \circ (f_0 \otimes f_1) = i \circ (g_0 \otimes g_1)$. We want to find a factorisation $i = (h_0 \otimes h_1) \circ k$ for some morphism k . First, notice that $i \circ (B_0 \otimes f_1) = i \circ (B_0 \otimes g_1)$ (and, symmetrically, $i \circ (f_0 \otimes B_1) = i \circ (g_0 \otimes B_1)$). Indeed, we have:

$$\begin{aligned} i \circ (B_0 \otimes f_1) &= i \circ (B_0 \otimes f_1) \circ (f_0 \otimes A_1) \circ (r_0 \otimes A_1) \\ &= i \circ (f_0 \otimes f_1) \circ (r_0 \otimes A_1) \\ &= i \circ (g_0 \otimes g_1) \circ (r_0 \otimes A_1) \\ &= i \circ (B_0 \otimes g_1) \circ (g_0 \otimes A_1) \circ (r_0 \otimes A_1) \\ &= i \circ (B_0 \otimes g_1). \end{aligned}$$

Since the product is biclosed, the product by B_0 preserves the coequaliser formed by f_1, g_1 and h_1 . The universal property of this coequaliser gives us a factorisation $i = j \circ (B_0 \otimes h_1)$.

Let us now show that $j \circ (f_0 \otimes C_1) = j \circ (g_0 \otimes C_1)$, so that we can use the universal property of this other coequaliser. Since the product by A_0 preserves the coequalisers, $A_0 \otimes h_1$ is an epi, and it is enough to show that $j \circ (f_0 \otimes C_1) \circ (A_0 \otimes h_1) = j \circ (g_0 \otimes C_1) \circ (A_0 \otimes h_1)$. And indeed we have (using the fact that i equalises $f_0 \otimes B_1$ and $(g_0 \otimes B_1)$):

$$\begin{aligned} j \circ (f_0 \otimes C_1) \circ (A_0 \otimes h_1) &= j \circ (B_0 \otimes h_1) \circ (f_0 \otimes B_1) \\ &= i \circ (f_0 \otimes B_1) \\ &= i \circ (g_0 \otimes B_1) \\ &= j \circ (B_0 \otimes h_1) \circ (g_0 \otimes B_1) \\ &= j \circ (g_0 \otimes C_1) \circ (A_0 \otimes h_1) \end{aligned}$$

Using the universal property, we finally have that $j = k \circ (h_0 \otimes C_1)$ and so finally: $i = j \circ (B_0 \otimes h_1) = k \circ (h_0 \otimes C_1) \circ (C_0 \otimes h_1) = k \circ (h_0 \otimes h_1)$. The fact that such a factorisation is unique comes from the fact that $h_0 \otimes h_1$ is a composite of epimorphisms, and so is epi too. \square

Proposition 5.1.1.5. *Let \mathcal{C} be a category, and T be a monad on \mathcal{C} . Suppose the category $T\text{-Alg}$ of T -algebras is equipped with a biclosed monoidal product \otimes .*

Then the category $\mathbf{Mon}(T\text{-Alg})$ of monoid objects in $T\text{-Alg}$ is monadic over \mathcal{C} :

$$\begin{array}{ccc} \mathbf{Mon}(T\text{-Alg}) & \begin{array}{c} \xleftarrow{\quad} \\ \perp \\ \xrightarrow{\quad} \end{array} & T\text{-Alg} & \begin{array}{c} \xleftarrow{\quad} \\ \perp \\ \xrightarrow{\quad} \end{array} & \mathcal{C} \end{array}$$

Proof. We want to apply Proposition 5.1.1.3. The free monoid monad on $T\text{-Gpd}$ is given by

$$A \mapsto \coprod_{n \in \mathbb{N}} A^{\otimes n}$$

Let us show that this monad preserves reflexive coequalisers. Since colimits commute with colimits, we just have to show that $A \mapsto A^{\otimes n}$ preserves reflexive coequalisers. This is a direct consequence of Lemma 5.1.1.4. \square

The following definition is a generalisation by Mike Shulman of the construction of computads by Batanin [6], following the reformulation of Richard Garner in [28].

Definition 5.1.1.6. Let \mathcal{I} be a category whose objects are natural numbers, and such that for all non-identity morphism $f : i \rightarrow j$, we have $i < j$. Let T be a monad on $\hat{\mathcal{I}}$ (the category of presheaves over \mathcal{I}). For $A \in \hat{\mathcal{I}}$, we denote $A[n]$ by A_n . Let us define inductively the notion of n - T -polygraph, together with an adjunction between n - T -polygraphs and T -Algebras (U_n, F_n) . Let us denote by (U, F) the morphisms forming the adjunction between T -algebras and $\hat{\mathcal{I}}$.

- A 0- T -polygraph is just a set Σ_0 . The free T -algebra $F_0(\Sigma_0)$ generated by Σ_0 is $\Sigma_0 \cdot Y(0)$, where (\cdot) denotes the copower and $Y : \mathcal{I} \rightarrow \hat{\mathcal{I}}$ is the Yoneda embedding. If A is a T -algebra then $F_0(A) := U(A)_0$.
- Suppose n - T -polygraphs defined, together with F_n and U_n . Then an $(n+1)$ - T -polygraph is the data of an n - T -polygraph Σ , a set Σ_{n+1} and a morphism $\partial : \Sigma_{n+1} \cdot F(Y(\widetilde{n+1})) \rightarrow F_n(\Sigma)$, where $Y(\widetilde{n+1})$ is obtained from $Y(n+1)$ by removing $Y(n+1)_{n+1}$. Then the functor F_{n+1} is defined by the following pushout of T -algebras, where ι denoted the inclusion of $Y(\widetilde{n+1})$ into $Y(n+1)$:

$$\begin{array}{ccc} \Sigma_{n+1} \cdot F(Y(\widetilde{n+1})) & \xrightarrow{\partial} & F_n(\Sigma) \\ \Sigma_{n+1} \cdot F(\iota) \downarrow & & \downarrow \\ \Sigma_{n+1} \cdot F(Y(n+1)) & \longrightarrow & F_{n+1}(\Sigma, \Sigma_{n+1}, \partial) \end{array}$$

If A is a T -algebra, then let Σ_{n+1} and ∂ given by the following pullback:

$$\begin{array}{ccc} \Sigma_{n+1} & \longrightarrow & \text{hom}(F(Y(n+1)), A) \\ \partial \downarrow & & \downarrow \iota \\ \text{hom}(F(Y(\widetilde{n+1})), F_n U_n A) & \xrightarrow{\epsilon_n} & \text{hom}(F(Y(\widetilde{n+1})), A) \end{array}$$

where the bottom morphism is induced by the counit of the adjunction F_n, U_n , and the right-hand-side morphism comes from the inclusion of $Y(\widetilde{n+1})$ into $Y(n+1)$. We then define $U_{n+1}(A) := (U_n(A), \Sigma_{n+1}, \partial)$.

Finally, the category of ω - T -polygraph is the limit of the sequence of projection from $(n+1)$ - T -polygraphs to n - T -polygraphs.

Definition 5.1.1.7. We call *Gray monoids* or Gray $(\omega, 0)$ -monoids (resp. *Gray $(\omega, 1)$ -monoids*) the monoid objects in ω -groupoids (resp. $(\omega, 1)$ -categories), equipped with the Gray tensor product. By Proposition 5.1.1.5, Gray monoids (resp. Gray $(\omega, 1)$ -monoids) are monadic over pre cubical sets. We call the associated notion of polygraphs *Gray polygraphs* (resp. *Gray $(\omega, 1)$ -polygraphs*).

If Σ is a Gray (ω, p) -polygraph and $k \leq p$, we denote by $\Sigma^{G(k)}$ the free Gray (ω, k) -monoid generated by Σ .

5.1.2 Free Gray $(\omega, 1)$ -monoids are free $(\omega, 1)$ -categories

The aim of this Section is to prove that the Gray product of two free $(\omega, 1)$ -categories is still free. To do that, we show that the pushout-product of two cofibrations in ω -categories is still a cofibration (this is one of the axioms of a monoidal model category). It is a classical result of homotopy theory that it is sufficient to check this result on generating cofibrations. In the first part of this section, we choose our set of generating cofibrations carefully to simplify the computation of the pushout-product.

Proposition 5.1.2.1. *The free cubical ω -category functor $F : \omega\text{-CubSet} \rightarrow \omega\text{-CubCat}$ is monoidal.*

Proof. Let us denote by $U : \omega\text{-CubCat} \rightarrow \omega\text{-CubSet}$ the forgetful functor from cubical ω -category to pre-cubical sets, and $P : \omega\text{-CubSet} \rightarrow \omega\text{-CubSet}$ the functor forgetting dimension 0 and the direction-1 face in every dimension. The functor P also induces a functor $\tilde{P} : \omega\text{-CubCat} \rightarrow \omega\text{-CubCat}$. Moreover, we have for any cubical ω -category \mathcal{C} : $U\tilde{P}\mathcal{C} = PUC$.

Recall from [2] the internal Hom in $\omega\text{-CubCat}$ is given by $\underline{\omega\text{-CubCat}}(\mathcal{C}, \mathcal{D})_i = \omega\text{-CubCat}(\mathcal{C}, \tilde{P}^i\mathcal{D})$, and similarly in $\omega\text{-CubSet}$: $\underline{\omega\text{-CubSet}}(C, D)_i = \omega\text{-CubSet}(C, P^iD)$. So in the end we have, for any pre-cubical set C and any cubical ω -category \mathcal{C} :

$$\begin{aligned} \underline{\omega\text{-CubCat}}(F(C), \mathcal{C})_i &= \omega\text{-CubCat}(F(C), \tilde{P}^i\mathcal{C}) \\ &= \omega\text{-CubSet}(C, U\tilde{P}^i\mathcal{C}) \\ &= \omega\text{-CubSet}(C, P^iUC) \\ &= \underline{\omega\text{-CubSet}}(C, UC)_i \end{aligned}$$

Moreover, the pre-cubical set structures match, so that we have: $U\underline{\omega\text{-CubCat}}(F(C), \mathcal{C}) = \underline{\omega\text{-CubSet}}(C, UC)$.

So if C and D are pre-Cubical sets, we have for any cubical ω -category \mathcal{C} :

$$\begin{aligned} \omega\text{-CubCat}(F(C) \otimes F(D), \mathcal{C}) &= \omega\text{-CubCat}(F(C), \underline{\omega\text{-CubCat}}(F(D), \mathcal{C})) \\ &= \omega\text{-CubSet}(C, U\underline{\omega\text{-CubCat}}(F(D), \mathcal{C})) \\ &= \omega\text{-CubSet}(C, \underline{\omega\text{-CubSet}}(D, UC)) \\ &= \omega\text{-CubSet}(C \otimes D, UC) \\ &= \omega\text{-CubCat}(F(C \otimes D), \mathcal{C}) \end{aligned}$$

Since this is natural in \mathcal{C} , there is an isomorphism $F(C) \otimes F(D) = F(C \otimes D)$. □

Definition 5.1.2.2. We denote by $i_n : n\text{-}\bigcirc \rightarrow n\text{-}\bullet$ the inclusion of the n -sphere into the n -disk, and by $j_n : n\text{-}\square \rightarrow n\text{-}\blacksquare$ the inclusion of the n -shell into the n -cube.

Lemma 5.1.2.3. *There are pushouts of ω -categories:*

$$\begin{array}{ccc} n\text{-}\square & \longrightarrow & n\text{-}\bigcirc \\ j_n \downarrow & & \downarrow i_n \\ n\text{-}\blacksquare & \longrightarrow & n\text{-}\bullet \end{array} \quad \begin{array}{ccc} n\text{-}\circ & \longrightarrow & n\text{-}\square \\ i_n \downarrow & & \downarrow j_n \\ n\text{-}\bullet & \longrightarrow & n\text{-}\blacksquare \end{array}$$

Proof. The right-hand square comes from the fact that $n\text{-}\blacksquare$ is a free ω -category on a globular polygraph, where the $(n-1)$ -polygraph generates $n\text{-}\square$, and with exactly one generating n -cell. Similarly, the left-hand square comes from expressing $n\text{-}\bullet$ as a free ω -category generated by a cubical polygraph. \square

Lemma 5.1.2.4. *Let \mathcal{C} be a category, and let f, g be morphisms in \mathcal{C} . Suppose that g is a pushout of f . If h is a cell in \mathcal{C} having the right-lifting-property with respect to f , then it has the right-lifting property with respect to g .*

Proof. We are in the following situation:

$$\begin{array}{ccc} & \xrightarrow{k} & \xrightarrow{i} \\ f \downarrow & & \downarrow g \\ & \xrightarrow{k'} & \xrightarrow{i'} \\ & & \downarrow h \end{array}$$

Using the right-lifting-property of h with respect to f , we get a morphism u such that $u \circ f = i \circ k$ and $h \circ u = i' \circ k'$. Using the first equality and the fact that g is a pushout of f , we get a morphism v such that $v \circ g = i$ and $v \circ k' = u$:

$$\begin{array}{ccc} & \xrightarrow{k} & \xrightarrow{i} \\ f \downarrow & \searrow u & \downarrow g \\ & \xrightarrow{k'} & \xrightarrow{i'} \\ & & \downarrow h \end{array}$$

Let us show that v is the required lifting. The first equality is already given, it remains to show that $h \circ v = i'$.

Notice that since the big rectangle commutes, by universal property of g there is exactly one morphism w satisfying $w \circ k' = i' \circ k'$ and $w \circ g = h \circ i$. But both i' and $h \circ v$ satisfy this property:

$$\left\{ \begin{array}{l} i' \circ k' = i' \circ k' \\ i' \circ g = h \circ i \end{array} \right. \quad \left\{ \begin{array}{l} h \circ v \circ k' = h \circ u = i' \circ k' \\ h \circ v \circ g = h \circ i \end{array} \right.$$

Therefore, the two arrows are equal, and h does indeed have the right-lifting property with respect to g . \square

We are now armed to choose our set of generating cofibrations:

Proposition 5.1.2.5. *The family j_n forms a family of generating cofibrations for the model structure on $\omega\text{-Cat}$.*

Proof. Recall from [55] that the family i_n is a family of generating cofibrations for the model structure on $\omega\text{-Cat}$. The model structure is actually determined by the arrows having the right-lifting property with respect to the generating cofibrations. By Lemma 5.1.2.4 and 5.1.2.3, the arrows having the right lifting property with respect to i_n and j_n are actually the same, so they generate the same model structure. \square

Definition 5.1.2.6. If $f : \mathcal{C} \rightarrow \mathcal{D}$ and $f' : \mathcal{C}' \rightarrow \mathcal{D}'$ are two morphisms of ω -categories, The pushout-product of f and f' , denoted $f \hat{\otimes} f'$, is the following morphism, where \mathcal{E} is defined as a coproduct:

$$\begin{array}{ccc}
 \mathcal{C} \otimes \mathcal{C}' & \xrightarrow{f \otimes 1} & \mathcal{D} \otimes \mathcal{C}' \\
 1 \otimes f' \downarrow & & \downarrow \\
 \mathcal{C} \otimes \mathcal{D}' & \xrightarrow{\quad} & \mathcal{E} \\
 & \searrow f \hat{\otimes} f' & \downarrow 1 \otimes f' \\
 & & \mathcal{D} \otimes \mathcal{D}' \\
 & \nearrow f \otimes 1 & \\
 & &
 \end{array}$$

Proposition 5.1.2.7. For any $n, m \in \mathbb{N}$, we have:

$$j_n \otimes j_m = j_{n+m}$$

As a consequence, if f and g are two cofibrations, then $f \hat{\otimes} g$ is also a cofibration.

In particular, the product of two cofibrant objects is still cofibrant, that is: for any two polygraphs Σ and Γ , the ω -category $\Sigma^* \otimes \Gamma^*$ is free on a polygraph that we denote by $\Sigma \otimes \Gamma$.

Proof. Let us first compute \mathcal{E} . First we need to compute $(n-\square \otimes m-\square)$, $(n-\blacksquare \otimes m-\square)$ and $(n-\square \otimes m-\blacksquare)$. Since all those are free on pre-cubical sets, using 5.1.2.1 we can compute the products in cubical sets.

Recall that for all n , $n-\blacksquare$ is the free ω -category on the cubical set $n-\blacksquare^{Set}$, where $n-\blacksquare^{Set}$ is given by the set of all applications $s : \{1, \dots, n\} \rightarrow \{(-), (\theta), (+)\}$ such that $\#s^{-1}(\theta) = i$. We see such an element as a sequence of length n containing exactly i copies of (θ) . For such an s , and $1 \leq k \leq i$, $\partial_i^\alpha s$ is given by replacing the i -th (θ) appearing in s by (α) . Similarly, $n-\square^{Set}$ is obtained by removing the cell $(\theta \dots \theta)$.

Therefore, we have:

- The pre-cubical set $n-\square^{Set} \otimes m-\square^{Set}$ is the sub pre-cubical set of $(n+m)-\blacksquare^{Set}$ consisting of all $s : \{1, \dots, n+m\} \rightarrow \{(-), (\theta), (+)\}$ which are not of the form $(\theta \dots \theta \alpha_1 \dots \alpha_m)$ or $(\beta_1 \dots \beta_n \theta \dots \theta)$ for some $\alpha_1, \dots, \alpha_m, \beta_1, \dots, \beta_n \in \{(-), (\theta), (+)\}$.
- The pre-cubical set $n-\square^{Set} \otimes m-\blacksquare^{Set}$ is the sub pre-cubical set of $(n+m)-\blacksquare^{Set}$ consisting of all $s : \{1, \dots, n+m\} \rightarrow \{(-), (\theta), (+)\}$ which are not of the form $(\beta_1 \dots \beta_n \theta \dots \theta)$ for some $\beta_1, \dots, \beta_n \in \{(-), (\theta), (+)\}$.
- The pre-cubical set $n-\blacksquare^{Set} \otimes m-\square^{Set}$ is the sub pre-cubical set of $(n+m)-\blacksquare^{Set}$ consisting of all $s : \{1, \dots, n+m\} \rightarrow \{(-), (\theta), (+)\}$ which are not of the form $(\theta \dots \theta \alpha_1 \dots \alpha_m)$ for some $\alpha_1, \dots, \alpha_m \in \{(-), (\theta), (+)\}$.

Since all the j_n come from morphisms of pre-cubical sets, we can also form the coproduct in ω -**CubSet**. From the explicit descriptions above, we see that the coproduct in ω -**CubSet** is the sub-cubical set of $(n+m)-\blacksquare^{Set}$ consisting of all $s : \{1, \dots, n+m\} \rightarrow \{(-), (\theta), (+)\}$ that are either in $n-\square^{Set} \otimes m-\blacksquare^{Set}$ or in $n-\blacksquare^{Set} \otimes m-\square^{Set}$, that is of all s except for $(\theta \dots \theta)$. So finally $\mathcal{E} = (n+m)-\square$. On the other hand, by definition $n-\blacksquare \otimes m-\blacksquare = n+m-\blacksquare$. So $j_n \hat{\otimes} j_m$ and j_{n+m} share the same source and target, and explicit computation show that they both are the canonical inclusion of $(n+m)-\square$ into $(n+m)-\blacksquare$. So finally $j_n \hat{\otimes} j_m = j_{n+m}$.

The consequence about cofibrations is a standard result in model structure (see [45]), using the fact that the j_n form a generating family of cofibrations (Proposition 5.1.2.5).

Finally, since polygraphs correspond to cofibrant objects, for any polygraphs Σ and Γ the morphisms $f : \emptyset \rightarrow \Sigma^*$ and $f' : \emptyset \rightarrow \Gamma^*$ are cofibrations. Then $f \hat{\otimes} f'$ is just the (unique) morphism $\emptyset \rightarrow \Sigma^* \otimes \Gamma^*$. We just proved that it is a cofibration, meaning that $\Sigma^* \otimes \Gamma^*$ is a free category on a polygraph. \square

Remark 5.1.2.8. The fact that the product of two free ω -categories is still free is one of the main reasons for our use of the Gray tensor product over the cartesian one. Indeed, this fails for the cartesian product, as already noted by Lack [54]:

Let \mathcal{C} be the free category on one generator and one arrow. We have the isomorphism of monoids $\mathcal{C}(\bullet, \bullet) = \mathbb{N}$. Then $\mathcal{C} \otimes \mathcal{C}$ still only has one object and as a monoid $(\mathcal{C} \otimes \mathcal{C})(\bullet, \bullet) = \mathbb{N} \times \mathbb{N}$, which is not a free monoid.

Remark 5.1.2.9. The fact that the product of two free ω -categories is still free was also proven independently by Hadzihanovic [42], and by Ara and Maltsinotis. Explicitly, if Σ and Γ are two cubical ω -polygraphs. Then the cubical ω -polygraph $\Sigma \otimes \Gamma$ is given by:

$$(\Sigma \otimes \Gamma)_n = \coprod_{i+j=n} \Sigma_i \times \Gamma_j$$

$$\partial_k^\alpha(A \otimes B) = \begin{cases} \partial_k^\alpha A \otimes B & A \in \Sigma_i \text{ and } 1 \leq k \leq i \\ A \otimes \partial_{k-i}^\alpha B & A \in \Sigma_i \text{ and } i < k \end{cases}$$

Moreover, by definition of the product of two polygraphs, the free functor $\Sigma \mapsto \Sigma^*$ is monoidal.

Proposition 5.1.2.10. *Let Σ be a Gray polygraph. The free Gray monoid on Σ is also free as an $(\omega, 1)$ -category, generated by a cubical $(\omega, 1)$ -polygraph that we denote $[\Sigma]$, defined by:*

$$[\Sigma]_n = \coprod_{i_1 + \dots + i_k = n} \Sigma_{i_1} \times \dots \times \Sigma_{i_k} \quad (5.1.1)$$

$$\partial_{i_1 + \dots + i_j + l}^\alpha(A_1 \otimes \dots \otimes A_k) = A_1 \otimes \dots \otimes A_j \otimes \partial_l^\alpha A_{j+1} \otimes A_{j+2} \otimes \dots \otimes A_k, \text{ where } 1 \leq l \leq i_{j+1} \quad (5.1.2)$$

Proof. By Proposition 5.1.2.7, the free-category functor is strictly monoidal, and so it induces a functor from the category of monoidal objects in $(\omega, 1)$ -polygraphs to monoidal objects in $(\omega, 1)$ -categories (that is to Gray monoids). Finally, any Gray polygraph can be made into a monoidal object in $(\omega, 1)$ -polygraphs by sending a Gray polygraphs Σ to the $(\omega, 1)$ -polygraph $[\Sigma]$ given by the formulas (5.1.1) and (5.1.2).

The following diagram sums up the situation, where the right-hand square commutes because the free-category functor is monoidal, and the left-hand triangle is just the inclusion of Gray polygraphs into monoid objects in $(\omega, 1)$ -polygraphs.

$$\begin{array}{ccccc} \mathbf{GrayPol} & \hookrightarrow & \mathbf{MonPol} & \longrightarrow & (\omega, 1) - \mathbf{Pol} \\ & \searrow F & \downarrow F & & \downarrow F \\ & & \mathbf{GrayMon} & \longrightarrow & (\omega, 1) - \mathbf{CubCat} \end{array}$$

\square

Definition 5.1.2.11. Let Σ be an $(\omega, 1)$ -polygraph. We say that Σ is targets-only if for all $n \geq 2$, all $1 \leq i \leq n$ and all $A \in \Sigma_n$, $\partial_i^- A$ is in Σ_{n-1} .

We say that a Gray $(\omega, 1)$ -polygraph Σ is a targets-only polygraph if the $(\omega, 1)$ -polygraph $[\Sigma]$ is targets-only. Explicitly, for all $n \geq 2$, all $1 \leq i \leq n$ and all $A \in \Sigma_n$, there exists $A_1 \in \Sigma_{i_1}, \dots, A_k \in \Sigma_{i_k}$ such that $\partial_i^- A = A_1 \otimes \dots \otimes A_k$.

5.1.3 The simplicial monoid of local branchings

Proposition 5.1.3.1. *Let \mathbf{Cube} be the PROP generated by operations $\nabla, \nabla, \circ, \bullet$ and \circ, \bullet , subject to the following relations:*

$$\begin{array}{cccccc} \circ = | = \circ & \bullet = | = \bullet & \nabla = \nabla & \nabla = \nabla & \nabla = \nabla & \nabla = \nabla \\ \circ = \bullet = \circ & \bullet = \bullet = \bullet & \nabla = \bullet = \nabla & \bullet = \bullet = \bullet & \bullet = \bullet = \bullet & \bullet = \bullet = \bullet \end{array}$$

Let \mathbf{Simp} be the PROP defined by operations ∇, \circ , subject to the following relations:

$$\circ = | = \circ \quad \nabla = \nabla \quad \nabla = \nabla$$

The category of symmetric cubical sets, denoted \mathbf{CSet} is the category of presheaves on \mathbf{Cube} . Similarly, the category of augmented symmetric simplicial sets is denoted \mathbf{SSet} is the category of presheaves over \mathbf{Simp} . The inclusion functor $\mathbf{Simp} \rightarrow \mathbf{Cube}$ gives rise to an adjunction between \mathbf{SSet} and \mathbf{CSet} .

Moreover, the monoidal structures on \mathbf{Cube} and \mathbf{Simp} give rise by Day convolution to monoidal structures on augmented symmetric cubical sets and augmented symmetric simplicial sets. Define a cubical monoid (resp. a simplicial monoid) as a monoid object in \mathbf{CSet} (resp. \mathbf{SSet}). The functors in the adjunction preserve the monoidal structures, and so induce functors between the categories of cubical and simplicial monoids.

Definition 5.1.3.2. Let Σ be a monoidal 1-polygraph. A rewriting step f is an element of Σ_1^+ , the free Σ_0^* -bimodule. We call $\mathbf{s}(f)$ its source. A local n -branching (for $n > 0$) is an n -tuple (f_1, \dots, f_n) of rewriting steps of same source. We denote by $\mathbf{LocBr}(\Sigma)_n$ the set of all n -local branchings. We extend that to $n = 0$ by saying that a 0-local branching is just an element of Σ_0^* .

Definition 5.1.3.3. Let Σ be a monoidal 1-polygraph. We define:

- For all $(f_1, \dots, f_n) \in \mathbf{LocBr}(\Sigma)_n$, and $1 \leq i \leq n$. If $n = 1$ then we define $\partial_1 f = \mathbf{s}(f)$ and otherwise, let $\partial_i(f_1, \dots, f_n)$ be the following $n - 1$ -branching:

$$(f_1, \dots, f_{i-1}, f_{i+1}, \dots, f_n)$$

- For all $(f_1, \dots, f_n) \in \mathbf{LocBr}(\Sigma)_n$, and $1 \leq i \leq n$, let $\epsilon_i(f_1, \dots, f_n)$ be the branching

$$(f_1, \dots, f_i, f_i, f_{i+1}, \dots, f_n)$$

- For all $(f_1, \dots, f_i) \in \mathbf{LocBr}(\Sigma)_i$ and $(g_1, \dots, g_j) \in \mathbf{LocBr}(\Sigma)_j$ respectively of source u and v , let $\bar{f} \otimes \bar{g}$

$$(ug_1, \dots, ug_j, f_1v, \dots, f_iv)$$

Finally, \mathfrak{S}_n acts on $\mathbf{LocBr}(\Sigma)$ by permuting the rewriting steps.

The following proposition is a straightforward verification of the axioms.

Proposition 5.1.3.4. *Let Σ be monoidal 1-polygraph. The family of local branchings $\mathbf{LocBr}(\Sigma)$ equipped with the applications ∂_i, ϵ_i and \otimes forms a simplicial monoid.*

Proposition 5.1.3.5. *The forgetful functor $U : (\omega, 1)\text{-Cat} \rightarrow \mathbf{CSet}$ is lax monoidal, that is there exists in \mathbf{CSet} a morphism $\epsilon : \top \rightarrow U(\top)$ and, naturally in $\mathbf{A}, \mathbf{B} \in \omega\text{-Cat}$ a morphism $\mu_{\mathbf{A}, \mathbf{B}} : U(\mathbf{A}) \otimes U(\mathbf{B}) \rightarrow U(\mathbf{A} \otimes \mathbf{B})$ satisfying the usual conditions.*

Proof. Notice that in the terminal cubical $(\omega, 1)$ -category there is only one cell in each dimension. Therefore, $U(\top) = \top$ and ϵ is defined as the identity. For the morphism $\mu_{\mathbf{A}, \mathbf{B}}$, recall that the product (of $(\omega, 1)$ -categories) $\mathbf{A} \otimes \mathbf{B}$ is generated by elements of the form $A \otimes B$ with $A \in \mathbf{A}$ and $B \in \mathbf{B}$. The map $A \otimes B \mapsto A \otimes B$ therefore induces a morphism $\mu_{\mathbf{A}, \mathbf{B}}$. \square

Proposition 5.1.3.6. *The functor U induces a functor from Gray $(\omega, 1)$ -monoids to cubical monoids.*

Proof. More generally, a lax monoidal functor between two monoidal categories induces a functor between the categories of monoidal objects in the two categories. \square

Definition 5.1.3.7. We denote by V the composite of the forgetful functor from Gray $(\omega, 1)$ -monoids to cubical monoids with the one from cubical monoid to simplicial monoids.

Theorem 5.1.3.8. *Let Σ be a terminating targets-only Gray $(\omega, 1)$ -polygraph, and let $M = \Sigma_0^{G(0)} / \Sigma_1^{G(0)}$ be the monoid presented by Σ . We suppose that there exists a morphism of simplicial monoids*

$$\Phi : \mathbf{LocBr}(\Sigma) \rightarrow V(\Sigma^{G(1)})$$

such that for all $A \in \Sigma$, $\Phi(\mathbf{br}(A)) = A$.

Then the morphism $\Sigma^{G(0)} \rightarrow M$ is an equivalence of ω -groupoids.

5.2 Proof of Theorem 5.1.3.8

The proof of Theorem 5.1.3.8 in Section 5.2.3 relies on the description of a complicated composite of cells. To simplify the expression of this composite, we introduce two main tools: in Section 5.2.2, we introduce a generalised notion of connection, built in any cubical $(\omega, 1)$ -category as a composite of connections and of permutations, while in Section 5.2.2 we introduce a generalised form of composition, similar to pasting schemes.

5.2.1 Generalised connections

Before defining new notions of connections, we start by defining new notations for operations on permutations.

Lemma 5.2.1.1. *Let $\sigma \in \mathfrak{S}_n$ et $i, j \leq n + 1$. There exists a unique permutation $\tau \in \mathfrak{S}_{n+1}$ satisfying*

$$\begin{cases} \partial_j \tau = \sigma \\ \tau \cdot j = i \end{cases}$$

Proof. It is the following permutation:

$$k \mapsto \begin{cases} (k_j \cdot \sigma)^i & k \neq j, \\ i & k = j. \end{cases}$$

□

Definition 5.2.1.2. We denote by $\sigma[i \mapsto j]$ the permutation such that

$$\begin{cases} \partial_i \sigma[i \mapsto j] = \sigma \\ \sigma[i \mapsto j] \cdot i = j \end{cases}$$

In particular if $\sigma = 1$, we simply write $[i \mapsto j]$.

Lemma 5.2.1.3. *The following equality hold for every $k \neq i$:*

$$\partial_k(\sigma[i \mapsto j]) = (\partial_{k_i} \sigma)[i_k \mapsto j_{(k_i \cdot \sigma)^j}]$$

In particular, we have $[i \mapsto j]^- = [j \mapsto i]$ and $\partial_k[i \mapsto j] = [i_k \mapsto j_{(k_i)^j}]$. For $k \neq j$, this last formula becomes $\partial_k[i \mapsto j] = [i_k \mapsto j_k]$.

Proof. Indeed, we have

$$\begin{cases} \partial_{i_k} \partial_k(\sigma[i \mapsto j]) & = \partial_{k_i} \partial_i(\sigma[i \mapsto j]) = \partial_{k_i} \sigma \\ i_k \cdot \partial_k(\sigma[i \mapsto j]) & = (i_k^k \cdot \sigma[i \mapsto j])_u, \end{cases}$$

where $u = k \cdot \sigma[i \mapsto j] = (k_i \cdot \sigma)^j$. Using the fact that $(i_k^k \cdot \sigma[i \mapsto j]) = i \cdot \sigma[i \mapsto j] = j$, we get the required formula. In the case where $k \neq j$, let us prove that $j_{(k_i)^j} = j_k$:

- If $k < i, j$ then $(k_i)^j = k^j = k$.
- If $i, j < k$ then $(k_i)^j = (k - 1)^j = k$.
- If $j < k < i$ then $(k_i)^j = k + 1$, and $j_{k+1} = j = j_k$.
- If $i < k < j$ then $(k_i)^j = k - 1$, and $j_{k-1} = j - 1 = j_k$.



Definition 5.2.1.4. Let \mathcal{C} be a cubical $(\omega, 1)$ -category. For any $n \geq 2$ and $1 \leq i \neq j \leq n$, we define $\Gamma_{i,j}^\alpha := [i \mapsto j_i] \cdot \Gamma_{j_i}^\alpha$. In particular, we have $\Gamma_i^\alpha = \Gamma_{i,i+1}^\alpha$.

Example 5.2.1.5. Diagrammatically, we can represent the generalised connections $\Gamma_{i,j}^\alpha$ as follows, respectively for $i < j$ and $i > j$:

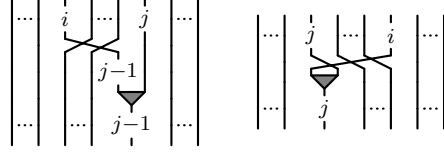

Proposition 5.2.1.6. For every $i \neq j$ and every α , the cell $\Gamma_{i,j}^\alpha$ is the only thin cell satisfying for every k and every β :

$$\begin{aligned} \partial_k^\beta \Gamma_{i,j}^\alpha A &= \Gamma_{i_k, j_k}^\alpha \partial_{k_i}^\beta A & k \neq i, j \\ \partial_i^\beta \Gamma_{i,j}^\alpha A &= \begin{cases} A & \beta = \alpha \\ \epsilon_{j_i} \partial_{j_i}^\beta A & \beta = -\alpha \end{cases} \\ \partial_j^\alpha \Gamma_{i,j}^\alpha A &= \begin{cases} [i_j \mapsto j_i] \cdot A & \beta = \alpha \\ \epsilon_{i_j} \partial_{j_i}^\beta A & \beta = -\alpha \end{cases} \end{aligned}$$

Proof. The cell $\Gamma_{i,j}^\alpha$ is thin by Lemma 4.2.3.3, and thin cells are uniquely determined by their shell. As for the relations, let $k \neq i, j$.

$$\partial_k^\beta \Gamma_{i,j}^\alpha A = \partial_k^\beta ([i \mapsto j_i] \cdot \Gamma_{j_i}^\alpha A) = \partial_k [i \mapsto j_i] \cdot \partial_{k \cdot [i \mapsto j_i]}^\beta \Gamma_{j_i}^\alpha A$$

We first evaluate $\partial_k [i \mapsto j_i]$. Using the formulas from Lemma 4.1.1.3, we have: $(k_i)^{j_i} = (k_{i_j})^{j_{ij}} = (k^j)_{ij}$. Hence, $a := (j_i)_{(k_i)^{j_i}} = (j_{ij})_{(k^j)_{ij}} = j_{ij, (k^j)} = j_{k^j, ij}$. Now $(i^j)_{k^j} = (i_{(k^j)_j})^{j_{k^j}} = (i_k)^{j_k}$ so $a = j_{k^j, (i_k)^{j_k}} = (j_k)_{(i_k)^{j_k}} = (j_k)_{i_k}$. And finally $\partial_k [i \mapsto j_i] = [i_k \mapsto (j_k)_{i_k}]$. We now consider the second term. Let $u = k \cdot [i \mapsto j_i] = (k_i)^{j_i}$. Then we have $u \neq j_i, j_i + 1$ and so

$$\partial_u^\beta \Gamma_{j_i}^\alpha A = \Gamma_{(j_i)_u}^\alpha \partial_{u_{j_i}}^\beta A = \Gamma_{j_i, k}^\alpha \partial_{k_i}^\beta A = \Gamma_{(j_k)_{i_k}}^\alpha \partial_{k_i}^\beta A$$

And so finally:

$$\partial_k^\beta \Gamma_{i,j}^\alpha A = [i_k \mapsto (j_k)_{i_k}] \cdot \Gamma_{(j_k)_{i_k}}^\alpha \partial_{k_i}^\beta A = \Gamma_{i_k, j_k}^\alpha \partial_{k_i}^\beta A$$

As for the other relations,

$$\begin{aligned} \partial_i^\beta \Gamma_{i,j}^\alpha A &= \partial_i^\beta ([i \mapsto j_i] \cdot \Gamma_{j_i}^\alpha A) = \partial_i [i \mapsto j_i] \cdot \partial_{i \cdot [i \mapsto j_i]}^\beta \Gamma_{j_i}^\alpha A \\ &= \partial_{j_i}^\beta \Gamma_{j_i}^\alpha A = \begin{cases} A & \beta = \alpha \\ \epsilon_{j_i} \partial_{j_i}^\beta A & \beta = -\alpha \end{cases} \\ \partial_j^\beta \Gamma_{i,j}^\alpha A &= \partial_j^\beta ([i \mapsto j_i] \cdot \Gamma_{j_i}^\alpha A) = \partial_j [i \mapsto j_i] \cdot \partial_{j \cdot [i \mapsto j_i]}^\beta \Gamma_{j_i}^\alpha A \\ &= [i_j \mapsto j_i] \cdot \partial_{j_{i+1}}^\beta \Gamma_{j_i}^\alpha A = \begin{cases} [j_i \mapsto i_j] \cdot A & \beta = \alpha \\ [j_i \mapsto i_j] \cdot \epsilon_{j_i} \partial_{j_i}^\beta A = \epsilon_{i_j} \partial_{j_i}^\beta A & \beta = -\alpha \end{cases} \end{aligned}$$



Lemma 5.2.1.7. For all $1 \leq i \neq j \leq n$, and $1 \leq k \leq n$ we have the equality $[k \mapsto i] \cdot \Gamma_{i,j}^\alpha = \Gamma_{k,(ji)^k}^\alpha$

Proof. Indeed, we have by definition of $\Gamma_{i,j}^\alpha$:

$$[k \mapsto i] \cdot \Gamma_{i,j}^\alpha = [k \mapsto i] \cdot [i \mapsto j] \cdot \Gamma_{j,i}^\alpha = [k \mapsto j] \cdot \Gamma_{j,i}^\alpha = [k \mapsto (ji)_k^k] \cdot \Gamma_{(ji)_k^k}^\alpha = \Gamma_{k,(ji)^k}^\alpha$$

□

Notation 5.2.1.8. Let $E \subset \mathbb{N}$ and $i \in \mathbb{N}$. Let us denote by E^i the set of elements of the form n^i , for $n \in E$. Similarly, if $i \notin E$, we denote by E_i the set of elements of the form n_i , for $n \in E$.

If $E \subset \mathbb{N}$ is finite, we denote by ϵ_E the composite $\epsilon_E = \epsilon_{i_1} \dots \epsilon_{i_n}$, where $E = \{i_1, \dots, i_n\}$ and $i_1 > i_2 > \dots > i_n$.

Definition 5.2.1.9. For any $n \geq 1$, $1 \leq i \leq n$, $m \geq 0$, $E \subset \{1, \dots, n+m\}$ of cardinality $m+1$ and $A \in \mathbf{C}_n$, we define a cell $\Gamma_i^{E,\alpha} A \in \mathbf{C}_{n+m}$ recursively on $n+m$ as follows:

- If $m = 0$, and $E = \{j\}$ then $\Gamma_i^{\alpha,E} := [j \mapsto i]$.
- Otherwise, then $\Gamma_i^{\alpha,E}$ is the only thin cell satisfying:

$$\partial_k^\alpha \Gamma_i^{\beta,E} = \begin{cases} \Gamma_{i_{(kE)^i}}^{\beta,E_k} \partial_{(kE)^i}^\alpha & k \notin E \\ \Gamma_i^{\beta,(E \setminus \{k\})_k} & k \in E \quad \alpha = \beta \\ \epsilon_{(E \setminus \{k\})_k} \partial_i^\alpha & k \in E \quad \alpha \neq \beta \end{cases}$$

Proof. We need to prove that there indeed exists a thin cell with the specified shell. Suppose $E = F \cup \{j\}$. and fix $k \in F$. Then we define: $\Gamma_i^{\alpha,E} := \Gamma_{j,k}^\alpha \Gamma_i^{\alpha,F_j}$. Let us check that the shell of this cell is the required one.

Case $l \notin E$:

$$\partial_l^\alpha \Gamma_i^{\beta,E} = \partial_l^\alpha \Gamma_{j,k}^\beta \Gamma_i^{\beta,F_j} = \Gamma_{j_l, k_l}^\beta \partial_{l_j}^\alpha \Gamma_i^{\beta,F_j} = \Gamma_{j_l, k_l}^\beta \Gamma_{i_{(l_j, F)^i}}^{\beta, F_j, l} \partial_{(l_j, F)^i}^\alpha$$

On the other hand, using the fact that $E_l = F_l \cup \{j_l\}$ and $k_l \in F_l$:

$$\partial_l^\alpha \Gamma_i^{\beta,E} = \Gamma_{i_{(lE)^i}}^{\beta, E_l} \partial_{(lE)^i}^\alpha = \Gamma_{j_l, k_l}^\beta \Gamma_{i_{(lE)^i}}^{\beta, F_j, l} \partial_{(lE)^i}^\alpha$$

And the two expressions coincide because $l_E = l_{j,F}$. Suppose now $l \in E$ and $\alpha = \beta$.

Case $l \in E$, $\alpha = \beta$ and $l \neq j, k$

$$\partial_l^\alpha \Gamma_i^{\alpha,E} = \partial_l^\alpha \Gamma_{j,k}^\alpha \Gamma_i^{\alpha,F_j} = \Gamma_{j_l, k_l}^\alpha \partial_{l_j}^\alpha \Gamma_i^{\alpha,F_j} = \Gamma_{j_l, k_l}^\alpha \Gamma_i^{\alpha, (F_j \setminus \{l_j\})_{l_j}}$$

and on the other hand, using the fact that $(E \setminus \{l\})_l = (F \setminus \{l\})_l \cup \{j_l\}$ and $k_l \in (F \setminus \{l\})_l$:

$$\partial_l^\alpha \Gamma_i^{\alpha,E} = \Gamma_i^{\alpha, (E \setminus \{l\})_l} = \Gamma_{j_l, k_l}^\alpha \Gamma_i^{\alpha, (F \setminus \{l\})_{l,j}}$$

And the two sides coincide using the fact that $(F_j \setminus \{l_j\})_{l_j} = (F \setminus \{l\})_{l,j}$.

Case $l \in E$, $\alpha = \beta$ and $l = j$:

$$\partial_j^\alpha \Gamma_i^{\alpha,E} = \partial_j^\alpha \Gamma_{j,k}^\alpha \Gamma_i^{\alpha,F_j} = \Gamma_i^{\alpha,F_j} = \Gamma_i^{\alpha, (E \setminus \{j\})_j} = \partial_j^\alpha \Gamma_i^{\alpha,E}$$

Case $l \in E$, $\alpha = \beta$ and $l = k$:

$$\partial_k^\alpha \Gamma_i^{\alpha,E} = \partial_k^\alpha \Gamma_{j,k}^\alpha \Gamma_i^{\alpha,F_j} = [j_k \mapsto k_j] \cdot \Gamma_i^{\alpha,F_j}$$

If $F = \{k\}$ then $\Gamma_i^{\alpha,F_j} = [k_j \mapsto i]$ and we have $\partial_k^\alpha \Gamma_i^{\alpha,E} = [j_k \mapsto i] = \Gamma_i^{\alpha,(E \setminus \{k\})_k}$. Otherwise, let $G \neq \emptyset$ such that $F = G \cup \{k\}$ and let $x \in G$. Then by induction $\Gamma_i^{\alpha,F_j} = \Gamma_{k_j,x_j}^\alpha \Gamma_i^{\alpha,(G_j)_{k_j}}$ and so, using Lemma 5.2.1.7:

$$\partial_k^\alpha \Gamma_i^{\alpha,E} = [j_k \mapsto k_j] \cdot \Gamma_{k_j,x_j}^\alpha \Gamma_i^{\alpha,G_j,k} = \Gamma_{j_k,x_k}^\alpha \Gamma_i^{\alpha,G_j,k} = \Gamma_i^{\alpha,(G \cup \{j\})_k} = \Gamma_i^{\alpha,(E \setminus \{k\})_k}$$

Case $l \in E$, $\alpha \neq \beta$ and $l \neq j, k$:

$$\begin{aligned} \partial_l^\alpha \Gamma_i^{\beta,E} &= \partial_l^\alpha \Gamma_{j,k}^\beta \Gamma_i^{\beta,F_j} = \Gamma_{j_l,k_l}^\beta \partial_l^\alpha \Gamma_i^{\beta,F_j} = \Gamma_{j_l,k_l}^\beta \epsilon_{(F \setminus \{l\})_{j,l}} \partial_l^\alpha \\ &= [j_l \mapsto k_{j,l}] \cdot \Gamma_{k_{j,l}}^\beta \epsilon_{(F \setminus \{l\})_{j,l}} \partial_l^\alpha = [j_l \mapsto k_{j,l}] \cdot \epsilon_{k_{j,l}} \epsilon_{(F \setminus \{l\})_{j,l}} \partial_l^\alpha \\ &= \epsilon_{j_l} \epsilon_{(F \setminus \{l\})_{j,l}} \partial_l^\alpha = \epsilon_{(F \setminus \{l\})_{j,l}} \partial_l^\alpha = \epsilon_{(E \setminus \{l\})_l} \partial_l^\alpha \end{aligned}$$

Case $l \in E$, $\alpha \neq \beta$ and $l = j$:

$$\partial_j^\alpha \Gamma_i^{\beta,E} = \partial_j^\alpha \Gamma_{j,k}^\beta \Gamma_i^{\beta,F_j} = \epsilon_{k_j} \partial_{k_j}^\alpha \Gamma_i^{\beta,F_j} = \epsilon_{k_j} \epsilon_{(F \setminus \{k\})_{j,k}} \partial_i^\alpha = \epsilon_{F_j} \partial_i^\alpha = \epsilon_{(E \setminus \{j\})_j} \partial_i^\alpha$$

Case $l \in E$, $\alpha \neq \beta$ and $l = k$:

$$\partial_k^\alpha \Gamma_i^{\beta,E} = \partial_k^\alpha \Gamma_{j,k}^\beta \Gamma_i^{\beta,F_j} = \epsilon_{j_k} \partial_{k_j}^\alpha \Gamma_i^{\beta,F_j} = \epsilon_{j_k} \epsilon_{(F \setminus \{k\})_{j,k}} \partial_i^\alpha = \epsilon_{(E \setminus \{k\})_k} \partial_i^\alpha$$

□

Example 5.2.1.10. The point of these generalised connections is to make use of the (co)associativity relation they verify. Together with the action of the symmetric group, it means that a (connected) composite of connections is uniquely determined by the indices of its set of output and by the index of its input. For example for $n = 4$, the connection $\Gamma_2^{\alpha,\{1,3,4\}}$ can equally be represented by any the following diagrams:

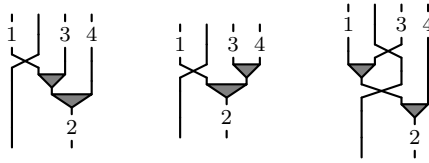

5.2.2 Generalised composition

If A and B are two 2-cells in a cubical ω -category, then one can talk of the following composites respectively as 2×1 and 1×2 composites. The goal of this Section is to formalise this idea and to extend it to higher dimension.

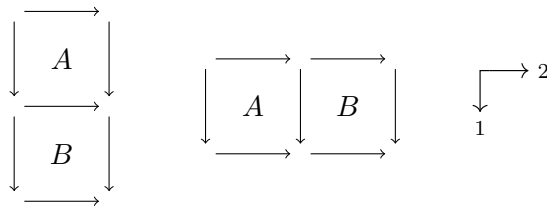

Notation 5.2.2.1. Let I be a finite totally ordered set, and $x \in I$. If $x \neq \mathbf{max}(I)$ (resp. $x \neq \mathbf{min}(I)$), we denote by $\mathbf{S}(x)$ (resp. $\mathbf{P}(x)$) the smallest element in I greater than x (resp. the greater element in I smaller than x).

Let I_1, \dots, I_n be totally ordered finite sets. For $s \in I_1 \times \dots \times I_n$, and $1 \leq i \leq n$ such that $s_i \neq \mathbf{max}(I_i)$ (resp. $s_i \neq \mathbf{min}(I_i)$). We denote by $\mathbf{S}_i s$ (resp. $\mathbf{P}_i s$) the element of $I_1 \times \dots \times I_n$ given by:

$$(\mathbf{S}_i s)_j = \begin{cases} s_j & j \neq i \\ \mathbf{S}(s_i) & j = i \end{cases} \quad (\mathbf{P}_i s)_j = \begin{cases} s_j & j \neq i \\ \mathbf{P}(s_i) & j = i \end{cases}$$

Definition 5.2.2.2. Let I_1, \dots, I_n be finite totally ordered non-empty sets, and \mathbf{C} be a cubical ω -category. An $I_1 \times \dots \times I_n$ -grid in \mathbf{C} is the data of a family of cells C_s in \mathbf{C}_n , for any $s \in I_1 \times \dots \times I_n$.

An $I_1 \times \dots \times I_n$ -grid C_\bullet is said to be *composable* if, for any $s \in I_1 \times \dots \times I_n$ such that $s_i \neq \mathbf{max}(I_i)$, $\partial_i^+ C_s = \partial_i^- C_{\mathbf{S}_i s}$.

Lemma 5.2.2.3. Let C_\bullet be a composable $I_1 \times \dots \times I_n$ -grid, and let $x \in I_i$ such that $x \neq \mathbf{max}(I_i)$. Let D_\bullet be the following $I_1 \times \dots \times I_{i-1} \times I_i \setminus \{x\} \times I_{i+1} \times \dots \times I_n$ -grid:

$$D_s = \begin{cases} C_s & s_i \neq \mathbf{S}(x) \\ C_{\mathbf{P}_i s} \star_i C_s & s_i = \mathbf{S}(x) \end{cases}$$

Then the grid D_\bullet is composable. We denote it by $\mathbf{comp}_x^i(C_\bullet)$.

Proof. Let $I'_j = I_j$ if $j \neq i$ and $I'_i = I_i \setminus \{x\}$. To avoid confusions, we denote by \mathbf{S}' and \mathbf{P}' the operations \mathbf{S} and \mathbf{P} taken in an I'_k . Let $t \in I'_1 \times \dots \times I'_n$ such that t_k is not maximal, and let us show that $\partial_k^+ D_t = \partial_k^- D_{\mathbf{S}'_k t}$. We distinguish multiple cases:

- If $k \neq i$ and $t_i \neq \mathbf{S}(x)$. Then $D_t = C_t$ and $D_{\mathbf{S}'_k t} = C_{\mathbf{S}_k t}$, and so the compositability of C_\bullet gives the required result.
- If $k \neq i$ and $t_i = \mathbf{S}(x)$. Then $D_t = C_{\mathbf{P}_i t} \star_i C_t$ and $D_{\mathbf{S}'_k t} = C_{\mathbf{P}_i \mathbf{S}_k t} \star_i C_{\mathbf{S}_k t}$, and so:

$$\partial_k^+ D_t = \partial_k^+ C_{\mathbf{P}_i t} \star_{i_k} \partial_k^+ C_t = \partial_k^- C_{\mathbf{S}_k \mathbf{P}_i t} \star_{i_k} \partial_k^- C_{\mathbf{S}_k t} = \partial_k^- (C_{\mathbf{P}_i \mathbf{S}_k t} \star_i C_{\mathbf{S}_k t}) = \partial_k^- D_{\mathbf{S}'_k t}$$

- If $k = i$ and $t_i \neq \mathbf{P}(x), \mathbf{S}(x)$, then $D_t = C_t$ and $D_{\mathbf{S}'_k t} = C_{\mathbf{S}_k t}$, and so the compositability of C_\bullet gives the required result.
- If $k = i$ and $t_i = \mathbf{P}(x)$, then $\partial_i^+ D_t = \partial_i^+ C_t$, and $\partial_i^- D_{\mathbf{S}'_i t} = \partial_i^- (C_{\mathbf{P}_i \mathbf{S}'_i t} \star_i C_{\mathbf{S}'_i t}) = \partial_i^- C_{\mathbf{P}_i \mathbf{S}'_i t} = \partial_i^- C_{\mathbf{S}_i t}$, and the two are equal by compositability of C_\bullet .
- The case where $k = i$ and $t_i = \mathbf{S}(x)$ is similar.

□

Proposition 5.2.2.4. Let I_1, \dots, I_n be finite non-empty totally ordered sets, and $x \in I_i$ and $y \in I_j$ be two distinct non-maximal elements. Then for any $I_1 \times \dots \times I_n$ -composable grid C_\bullet we have:

$$\mathbf{comp}_y^j \circ \mathbf{comp}_x^i(C_\bullet) = \mathbf{comp}_x^i \circ \mathbf{comp}_y^j(C_\bullet)$$

In particular, all the composite of maps of the form \mathbf{comp}_x^i from $I_1 \times \dots \times I_n$ -grids to composable $\top \times \dots \times \top$ -grids are equal (where \top denotes the terminal ordered set). Since a composable $\top \times \dots \times \top$ -grid is just an element of \mathbf{C}_n , this defines a map \mathbf{Comp} from composable $I_1 \times \dots \times I_n$ -grids to \mathbf{C}_n .

Proof. We distinguish two cases depending whether $i = j$ or not. If $i = j$, we can suppose without loss of generality that $x < y$. We then have, for all $t \in I_1 \times \dots \times I_n$ such that $t_i \neq x, y$:

- If $y = \mathbf{S}(x)$:

$$\begin{aligned} \mathbf{comp}_y^i \circ \mathbf{comp}_x^i(C_\bullet)_t &= \begin{cases} C_t & t_i \neq \mathbf{S}(y) \\ (C_{\mathbf{P}_i \mathbf{P}_i t} \star_i C_{\mathbf{P}_i t}) \star_i C_t & t_i = \mathbf{S}(y) \end{cases} \\ \mathbf{comp}_x^i \circ \mathbf{comp}_y^i(C_\bullet)_t &= \begin{cases} C_t & t_i \neq \mathbf{S}(y) \\ C_{\mathbf{P}_i \mathbf{P}_i t} \star_i (C_{\mathbf{P}_i t} \star_i C_t) & t_i = \mathbf{S}(y) \end{cases} \end{aligned}$$

Using the associativity of \star_i , the two are equal.

- If $y \neq \mathbf{S}(x)$, then we have the following formula (once again symmetric in x and y):

$$\mathbf{comp}_y^i \circ \mathbf{comp}_x^i(C_\bullet)_t = \begin{cases} C_t & t_i \neq \mathbf{S}(x), \mathbf{S}(y) \\ C_{\mathbf{P}_i t} \star_i C_t & t_i = \mathbf{S}(x), \mathbf{S}(y) \end{cases}$$

Suppose now that $i \neq j$. Then we have:

$$\mathbf{comp}_y^j \circ \mathbf{comp}_x^i(C_\bullet)_t = \begin{cases} C_t & t_j \neq \mathbf{S}(x) \text{ and } t_i \neq \mathbf{S}(y) \\ C_{\mathbf{P}_i t} \star_i C_t & t_i = \mathbf{S}(x) \text{ and } t_j \neq \mathbf{S}(y) \\ C_{\mathbf{P}_j t} \star_i C_t & t_i \neq \mathbf{S}(x) \text{ and } t_j = \mathbf{S}(y) \\ (C_{\mathbf{P}_i \mathbf{P}_j t} \star_i C_{\mathbf{P}_j t}) \star_j (C_{\mathbf{P}_i t} \star_i C_t) & t_i = \mathbf{S}(x) \text{ and } t_j = \mathbf{S}(y) \end{cases}$$

Using the fact that $\mathbf{P}_i \mathbf{P}_j = \mathbf{P}_j \mathbf{P}_i$ and the exchange law between \star_i and \star_j , the expression is symmetric in x and y . \square

Definition 5.2.2.5. Let C_\bullet be a composable $I_1 \times \dots \times I_n$ -grid in a cubical ω -category \mathbf{C} , and let $A \in \mathbf{C}_n$. Let us denote by m_i the minimum of I_i and let m be the element of $I_1 \times \dots \times I_n$ formed by those minimums. We say that C_\bullet is an *A-simple grid* if for all $s \in I_1 \times \dots \times I_n$, $C_{\mathbf{S}_i s} \in \mathbf{Im}(\epsilon_i)$ and $C_m = A$.

Lemma 5.2.2.6. Let C_\bullet be an *A-simple composable $I_1 \times \dots \times I_n$ -grid* in a cubical ω -category \mathbf{C} , for some $A \in \mathbf{C}_n$. Let m_i be the minimum of I_i . If m_i is not maximal in I_i (that is, if $I_i \neq \top$), then $\mathbf{comp}_{m_i}^i C_\bullet$ is an *A-simple $I_1 \times \dots \times I_i \setminus \{m_i\} \times \dots \times I_n$ -grid*.

Proof. Let $D_\bullet = \mathbf{comp}_{m_i}^i(C_\bullet)$, and let $t \in I_1 \times \dots \times I_i \setminus \{m_i\} \times \dots \times I_n$. Then we have:

- If $t_i \neq \mathbf{S}(m_i)$, then $D_{\mathbf{S}_k t} = C_{\mathbf{S}_k t} \in \mathbf{Im}(\epsilon_k)$.
- If $t_i = \mathbf{S}(m_i)$ and $k = i$ then $D_{\mathbf{S}_i t} = C_{\mathbf{S}_i t} \in \mathbf{Im}(\epsilon_i)$.
- If $t_i = \mathbf{S}(m_i)$ and $k \neq i$ then $D_{\mathbf{S}_k t} = C_{\mathbf{P}_i \mathbf{S}_k t} \star_i C_{\mathbf{S}_k t} = C_{\mathbf{S}_k \mathbf{P}_i t} \star_i C_{\mathbf{S}_k t}$. By hypothesis both $C_{\mathbf{S}_k \mathbf{P}_i t}$ and $C_{\mathbf{S}_k t}$ are in $\mathbf{Im}(\epsilon_k)$ and so so is $D_{\mathbf{S}_k t}$.

Finally, if $t_j = m_j$ for all $j \neq i$ and $t_i = \mathbf{S}(m_i)$ then $D_t = C_{\mathbf{P}_i t} \star_i C_t = A \star_i C_{\mathbf{S}_i m} = A$ because $C_{\mathbf{S}_i m} \in \mathbf{Im}(\epsilon_i)$. So finally D_\bullet is an *A-simple grid*. \square

Proposition 5.2.2.7. Let C_\bullet be an *A-simple grid*. Then $\mathbf{Comp}(C_\bullet) = A$.

Proof. We reason by induction on the sum of the cardinalities of I_1, \dots, I_n . If they are all singletons then C_\bullet is just the data of A and so $\mathbf{Comp}(C_\bullet) = A$. Otherwise, then there exists $1 \leq i \leq n$ such that I_i is not a singleton. Let m_i be the minimum of I_i . By Lemma 5.2.2.6, $\mathbf{comp}_{m_i}^i(C_\bullet)$ is an *A-simple grid*. Using the induction hypothesis, we therefore have $\mathbf{Comp}(C_\bullet) = \mathbf{Comp}(\mathbf{comp}_{m_i}^i(C_\bullet)) = A$. \square

5.2.3 Construction of the normalisation strategy

Let us fix a Gray $(\omega, 1)$ -polygraph Σ satisfying the hypothesis of Theorem 5.1.3.8. Let M be the monoid presented by Σ , and let us denote by $\mathbf{NF} : M \rightarrow \Sigma^{G(0)}$ the inclusion of the normal forms, and by $\pi : \Sigma^{G(0)} \rightarrow M$ the canonical projection. Note that π is a morphism of Gray monoids, while \mathbf{NF} is just a morphism of ω -groupoids. We are going to show that the two from an equivalence of ω -groupoid.

Note first that $\pi \circ \mathbf{NF} = id_M$. We now need to define a natural transformation $S : id_{\Sigma^{G(0)}} \Rightarrow \mathbf{NF} \circ \pi$. To do that, we start by making use of the fact that Σ is a Gray $(\omega, 1)$ -polygraph and that \mathbf{NF} and π are induced by morphisms of $(\omega, 1)$ -categories. This means that we can start by defining a natural transformation $S : id_{\Sigma^{G(1)}} \Rightarrow \mathbf{NF} \circ \pi$.

Using the fact that $\Sigma^{G(1)}$ is the free $(\omega, 1)$ -category on the $(\omega, 1)$ -polygraph $[\Sigma]$, constructing S amounts to finding, for any $A \in [\Sigma]_n$, a cell $S(A) \in [\Sigma]_{n+1}^{*(1)}$, satisfying the following relations (recursively in n):

- $\partial_1^- S(A) = A$.
- $\partial_1^+ S(A) = \mathbf{NF} \circ \pi(A)$
- For $1 \leq i \leq n$ and $\alpha = \pm$, $\partial_{i+1}^\alpha S(A) = S(\partial_i^\alpha(A))$.

Definition 5.2.3.1. Let $A \in [\Sigma]_n$. There exists $A_1, \dots, A_k \in \Sigma_{i_1} \times \dots \times \Sigma_{i_k}$ such that $A = A_1 \otimes \dots \otimes A_k$. Let $f := \mathbf{br}(A_1) \otimes \dots \otimes \mathbf{br}(A_k)$ and let u be the source of f . Let $\bar{g} := (\tau_u, f)$: we denote by τ_A the cell $\Phi(\bar{g}) \in [\Sigma]_{n+1}^{*(1)}$.

Lemma 5.2.3.2. Let $A \in [\Sigma]_n$. For all $1 \leq i \leq n+1$,

$$\partial_i^- \tau_A = \begin{cases} A & i = 1 \\ \tau_{\partial_{i-1}^- A} & i > 1 \end{cases}$$

Note in particular that $\tau_{\partial_{i-1}^- A}$ is well-defined because $[\Sigma]$ is a targets-only $(\omega, 1)$ -polygraph.

Proof. Let f_1, \dots, f_n be rewriting steps such that $f = (f_1, \dots, f_n)$. Then $\partial_1^- \tau_A = \partial_1^- \Phi(\tau_u, f_1, \dots, f_n) = \Phi(\partial_1(\tau_u, f_1, \dots, f_n)) = \Phi(f_1, \dots, f_n) = A$.

And for $i > 1$, $\partial_i^- \tau_A = \Phi(\tau_u, f_1, \dots, f_{i-2}, f_i, \dots, f_n) = \Phi(\tau_u, \mathbf{br}(\partial_{i-1}^- A))$. Since $[\Sigma]$ is a targets-only $(\omega, 1)$ -polygraph, $\partial_{i-1}^- A$ is in $[\Sigma]_{n-1}$ and so $\tau_{\partial_{i-1}^- A} = \Phi(\tau_u, \mathbf{br}(\partial_{i-1}^- A))$. \square

Definition 5.2.3.3. For any (ω, k) -polygraph Σ , we denote by $\Sigma_{<n}$ the $(n-1, k)$ -polygraph obtained by truncating Σ , and by $\iota_n : [\Sigma]_{<n}^{*(1)} \rightarrow [\Sigma]^{*(1)}$ the canonical inclusion.

Proposition 5.2.3.4. Let Σ be a targets-only terminating Gray $(\omega, 1)$ -polygraph, and let $M = \Sigma_0^{G(0)} / \Sigma_1^{G(0)}$ be the monoid presented by Σ .

Suppose that there exists a morphism of augmented symmetric simplicial sets

$$\Phi : \mathbf{BrLoc}(\Sigma)_{\leq n} \rightarrow V(\Sigma^{G(1)})$$

such that for all $A \in [\Sigma]_{\leq n}$, $\Phi(\mathbf{br}(A)) = A$.

For any $A \in [\Sigma]_{\leq n}$, let $\tau_A \in \Sigma^{G(1)}$ be the cell defined as in Definition 5.2.3.1). Then there exists a unique natural transformation S from ι_n to $\mathbf{NF} \circ \pi$ such that for any $A \in [\Sigma]_m$ for

$m < n$, the $\{-1, 0, 1\} \times \{0, 1\}^m$ -grid C_\bullet^A defined as follows

$$C_s^A = \begin{cases} \tau_A & s = (0, \dots, 0) \\ \epsilon_1 A & s = (-1, 0, \dots, 0) \\ \Gamma_1^-, s^-(1) \Gamma_1^+ S(\partial_1^- \partial_{s^-(1)}^+ \tau_A) & s(1) = -1 \\ \Gamma_1^-, s^-(1) S(\partial_{s^-(1)}^+ \tau_A) & s(1) \neq -1 \end{cases} \quad (5.2.1)$$

is composable and $S(A) = \mathbf{Comp}(C_\bullet^A)$.

Case $n = 0$ We define S inductively on $u \in [\Sigma]_0$. If u is a normal form for Σ_1 then $S(u) = 1_u$, otherwise formula (5.2.1) become simply $S(u) = \epsilon_1 u \star_1 \tau_u \star_1 S(\partial_1^+ \tau_u) = \tau_u \star_1 S(\partial_1^+ \tau_u)$. Denoting by u' the target of τ_u , we have:

$$S(u) := u \xrightarrow{\tau_u} u' \xrightarrow{S(u')} \hat{u}$$

Case $n = 1$ Let $f : u \rightarrow v \in [\Sigma]_1$. We reason by induction on $u = \partial_1^- f$. Let us denote by u' the target of τ_u . Then Formula (5.2.1) gives us the following formula for $S(f)$. Remark in particular that the faces satisfy the required conditions:

$$S(f) := \begin{array}{ccccc} u & \xrightarrow{f} & v & \xlongequal{\quad} & v \\ \parallel & \epsilon_1 f & \parallel & \Gamma_1^+ S(v) & \downarrow S(v) \\ u & \xrightarrow{f} & v & \xrightarrow{S(v)} & \hat{u} \\ \tau_u \downarrow & \tau_f & \downarrow & T_1 S(\partial_2^+ \tau_f) & \parallel \\ u' & \xrightarrow{\quad} & w & \xrightarrow{S(w)} & \hat{u} \\ S(u') \downarrow & S(\partial_1^+ \tau_f) & \downarrow S(w) & \Gamma_1^- S(w) & \parallel \\ \hat{u} & \xlongequal{\quad} & \hat{u} & \xlongequal{\quad} & \hat{u} \end{array} \quad \begin{array}{l} \downarrow \rightarrow 2 \\ \downarrow 1 \end{array}$$

General case Let us fix an $k > m > 0$, and let $A \in [\Sigma]_m$. We reason by induction on the source $u \in [\Sigma]_0$ of A . Suppose that S is defined on any generator of source smaller than u . Let C_\bullet^A be the grid defined by (5.2.1).

Lemma 5.2.3.5. *The $\{-1, 0, 1\} \times \{0, 1\}^m$ -grid C_\bullet^A is composable.*

Proof. Let us decompose $A = A_1 \otimes \dots \otimes A_p$, with $A_j \in \Sigma_{m_j}$ for $1 \leq j \leq p$. Let $\bar{f}^i := \mathbf{br}(A_i)$, $\bar{f} = \mathbf{br}(A)$ and $\bar{g} = (\tau_u, \bar{f})$.

We need to check that for all s and for all i , $\partial_i^+ C_s^A = \partial_i^- C_{\mathbf{S}_i s}^A$. Let us first check the case $s = (-1, 0, \dots, 0)$. For $i = 1$ we have:

$$\partial_1^+ C_s^A = A = \partial_1^- \tau_A = \partial_1^- C_{\mathbf{S}_1 s}^A$$

And for $i \neq 1$, we have (using the fact that $(\mathbf{S}_i s)^-(1) = \{i\}$):

$$\begin{aligned}
\partial_i^+ C_s^A &= \epsilon_1 \partial_{i-1}^+ A \\
\partial_i^- C_{\mathbf{S}_i s}^A &= \partial_i^- \Gamma_1^{-, (\mathbf{S}_i s)^-(1)} \Gamma_1^+ S(\partial_1^- \partial_{(\mathbf{S}_i s)^-(1)}^+ \tau_A) \\
&= \partial_i^- \Gamma_1^{-, i} \Gamma_1^+ S(\partial_1^- \partial_i^+ \tau_A) \\
&= \partial_i^- [i \mapsto 1] \Gamma_1^+ S(\partial_{i-1}^+ \partial_1^- \tau_A) \\
&= \partial_1^- \Gamma_1^+ S(\partial_{i-1}^+ A) = \epsilon_1 \partial_1^- S(\partial_{i-1}^+ A) = \epsilon_1 \partial_{i-1}^+ A
\end{aligned}$$

Let us now check the case $s = (0, \dots, 0)$. Then once again $(\mathbf{S}_i s)^-(1) = \{i\}$, and we have:

$$\begin{aligned}
\partial_i^+ C_s^A &= \partial_i^+ \tau_A \\
\partial_i^- C_{\mathbf{S}_i s}^A &= \partial_i^- \Gamma_1^{-, (\mathbf{S}_i s)^-(1)} S(\partial_{s^-(1)}^+ \tau_A) \\
&= \partial_i^- [i \mapsto 1] S(\partial_i^+ \tau_A) = \partial_1^- S(\partial_i^+ \tau_A) = \partial_i^+ \tau_A
\end{aligned}$$

Suppose now $s(1) = -1$. Then we distinguish two cases.

- If $i = 1$ then $(\mathbf{S}_1 s)^-(1) = s^-(1)$ and we have:

$$\begin{aligned}
\partial_1^+ C_s^A &= \partial_1^+ \Gamma_1^{-, s^-(1)} \Gamma_1^+ S(\partial_1^- \partial_{s^-(1)}^+ \tau_A) = \Gamma_1^{-, s^-(1)-1} \partial_2^+ \Gamma_1^+ S(\partial_1^- \partial_{s^-(1)}^+ \tau_A) \\
&= \Gamma_1^{-, s^-(1)-1} S(\partial_1^- \partial_{s^-(1)}^+ \tau_A) \\
\partial_1^- C_{\mathbf{S}_1 s}^A &= \partial_1^- \Gamma_1^{-, s^-(1)} S(\partial_{s^-(1)}^+ \tau_A) = \Gamma_1^{-, s^-(1)-1} \partial_2^- S(\partial_{s^-(1)}^+ \tau_A) \\
&= \Gamma_1^{-, s^-(1)-1} S(\partial_1^- \partial_{s^-(1)}^+ \tau_A)
\end{aligned}$$

- If $i \neq 1$, note first that $i_{s^-(1)} + 1 \neq 1, 2$. Indeed, if $i_{s^-(1)} + 1 = 2$ then $i_{s^-(1)} = 1$, and so $\{1, \dots, i-1\} \subset s^-(1)$ which is impossible since $s(1) = -1$. So finally we have:

$$\begin{aligned}
\partial_i^+ C_s^A &= \partial_i^+ \Gamma_1^{-, s^-(1)} \Gamma_1^+ S(\partial_1^- \partial_{s^-(1)}^+ \tau_A) \\
&= \Gamma_1^{-, s^-(1)} \partial_{i_{s^-(1)}+1}^+ \Gamma_1^+ S(\partial_1^- \partial_{s^-(1)}^+ \tau_A) \\
&= \Gamma_1^{-, s^-(1)} \Gamma_1^+ \partial_{i_{s^-(1)}}^+ S(\partial_1^- \partial_{s^-(1)}^+ \tau_A) \\
&= \Gamma_1^{-, s^-(1)} \Gamma_1^+ S(\partial_{i_{s^-(1)}-1}^+ \partial_1^- \partial_{s^-(1)}^+ \tau_A) \\
&= \Gamma_1^{-, s^-(1)} \Gamma_1^+ S(\partial_1^- \partial_{i_{s^-(1)}}^+ \partial_{s^-(1)}^+ \tau_A) \\
&= \Gamma_1^{-, s^-(1)} \Gamma_1^+ S(\partial_1^- \partial_{i, s^-(1)}^+ \tau_A) \\
\partial_i^- C_{\mathbf{S}_i s}^A &= \partial_i^- \Gamma_1^{-, \mathbf{S}_i s^-(1)} \Gamma_1^+ S(\partial_1^- \partial_{\mathbf{S}_i s^-(1)}^+ \tau_A) \\
&= \Gamma_1^{-, s^-(1)} \Gamma_1^+ S(\partial_1^- \partial_{i, s^-(1)}^+ \tau_A)
\end{aligned}$$

Suppose finally that $s(1) \neq -1$ and that $s \neq (0, \dots, 0)$. Then we have:

$$\begin{aligned}
\partial_i^+ C_s^A &= \partial_i^+ \Gamma_1^{-,s^-(1)} S(\partial_{s^-(1)}^+ \tau_A) \\
&= \Gamma_1^{-,s^-(1)i} \partial_{i_{s^-(1)+1}}^+ S(\partial_{s^-(1)}^+ \tau_A) \\
&= \Gamma_1^{-,s^-(1)i} S(\partial_{i_{s^-(1)}}^+ \tau_A) \\
\partial_i^- C_{\mathbf{S}_i s}^A &= \partial_i^- \Gamma_1^{-,\mathbf{S}_i s^-(1)} S(\partial_{\mathbf{S}_i s^-(1)}^+ \tau_A) \\
&= \Gamma_1^{-,s^-(1)i} S(\partial_{i_{s^-(1)}}^+ \tau_A).
\end{aligned}$$

So in all cases we have $\partial_i^+ C_s^A = \partial_i^- C_{\mathbf{S}_i s}^A$, which means that the family C_s^A is composable. \square

Lemma 5.2.3.6. *The following equation holds:*

$$\partial_i^\alpha \mathbf{Comp}(C_\bullet^A) = \begin{cases} A & \alpha = - \text{ and } i = 1 \\ \mathbf{NF}(A) & \alpha = + \text{ and } i = 1 \\ S(\partial_{i-1}^\alpha A) & i \neq 1 \end{cases}$$

Proof. We start by the case $i = 1$ and $\alpha = -$. Let us define $D_s^A := \partial_1^- C_{(-1,s)}^A$. Then $\partial_1^- \mathbf{Comp}(C_\bullet^A) = \mathbf{Comp}(D_\bullet^A)$. Moreover, we have, for $s \neq (0, \dots, 0)$:

$$\begin{aligned}
D_s^A &= \partial_1^- \Gamma_1^{-,s^-(1)+1} \Gamma_1^+ S(\partial_1^- \partial_{s^-(1)+1}^+ \tau_A) \\
&= \Gamma_1^{-,s^-(1)} \epsilon_1 \partial_1^- S(\partial_1^- \partial_{s^-(1)+1}^+ \tau_A) \\
&= \epsilon_{s^-(1)} \partial_1^- \partial_{s^-(1)+1}^+ \tau_A
\end{aligned}$$

In particular, for any $1 \leq i \leq n$, $D_{\mathbf{S}_i s}^A \in \mathbf{Im}(\epsilon_i)$, and D_\bullet^A is a $D_{(0,\dots,0)}^A$ -simple grid. By Proposition 5.2.2.7 $\mathbf{Comp}(D_s^A) = D_{(0,\dots,0)}^A = \partial_1^- C_{(-1,0,\dots,0)}^A = \partial_1^- \tau_A = A$.

We now to the case $i = 1$ and $\alpha = +$. Let us define $D_s^A := \partial_1^+ C_{(1,s)}^A$. Then we have:

$$\begin{aligned}
D_s^A &= \partial_1^+ \Gamma_1^{-,1,s^-(1)+1} S(\partial_{1,s^-(1)+1}^+ \tau_A) \\
&= \epsilon_{1,s^-(1)+1} \partial_1^+ S(\partial_{1,s^-(1)+1}^+ \tau_A) \\
&= \epsilon_{1,s^-(1)+1} \mathbf{NF}(\partial_{1,s^-(1)+1}^+ \tau_A) = \mathbf{NF}(A)
\end{aligned}$$

So finally $\mathbf{Comp}(D_s^f) = \mathbf{NF}(A)$.

Let now $i \neq 1$ and $\alpha = -$. For t an element of $\{-1, 0, 1\} \times \{0, 1\}^{n-1}$, let us denote by t_{-i} the element of $\{-1, 0, 1\} \times \{0, 1\}^n$ obtained by inserting a 0 in t in the i -th position. Define $D_t^A := \partial_i^- C_{t_{-i}}^A$. Then we have:

- For $t = (0, \dots, 0)$, $D_t^A = \partial_i^- \tau_A = \tau_{\partial_{i-1}^- A}$.
- For $t = (-1, 0, \dots, 0)$, $D_t^A = \partial_i^- \epsilon_1 A = \epsilon_1 \partial_{i-1}^- A$.

- If $t(1) = -1$, then let $s = t_{-i}$. Then we also have $s(1) = -1$ and $(s^{-}(1))_i = t^{-}(1)$. So:

$$\begin{aligned}
D_t^A &= \partial_i^- \Gamma_1^{-,s^{-}(1)} \Gamma_1^+ S(\partial_1^- \partial_{s^{-}(1)}^+ \tau_A) \\
&= \Gamma_1^{-,t^{-}(1)} \partial_{i_{s^{-}(1)}+1}^- \Gamma_1^+ S(\partial_1^- \partial_{s^{-}(1)}^+ \tau_A) \\
&= \Gamma_1^{-,t^{-}(1)} \Gamma_1^+ \partial_{i_{s^{-}(1)}}^- S(\partial_1^- \partial_{s^{-}(1)}^+ \tau_A) \\
&= \Gamma_1^{-,t^{-}(1)} \Gamma_1^+ S(\partial_{i_{s^{-}(1)}-1}^- \partial_1^- \partial_{s^{-}(1)}^+ \tau_A) \\
&= \Gamma_1^{-,t^{-}(1)} \Gamma_1^+ S(\partial_1^- \partial_{i_{s^{-}(1)}}^- \partial_{s^{-}(1)}^+ \tau_A) \\
&= \Gamma_1^{-,t^{-}(1)} \Gamma_1^+ S(\partial_1^- \partial_{t^{-}(1)}^+ \partial_i^- \tau_A) \\
&= \Gamma_1^{-,t^{-}(1)} \Gamma_1^+ S(\partial_1^- \partial_{t^{-}(1)}^+ \tau_{\partial_{i-1}^- A})
\end{aligned}$$

- Finally, if $t(1) \neq 1$, once again let $s = t_{-i}$. Then we still have $s(1) \neq -1$ and $(s^{-}(1))_i = t^{-}(1)$, so that:

$$\begin{aligned}
D_t^A &= \partial_i^- \Gamma_1^{-,s^{-}(1)} S(\partial_{s^{-}(1)}^+ \tau_A) \\
&= \Gamma_1^{-,t^{-}(1)} \partial_{i_{s^{-}(1)}}^- S(\partial_{s^{-}(1)}^+ \tau_A) \\
&= \Gamma_1^{-,t^{-}(1)} \partial_{i_{s^{-}(1)}+1}^- S(\partial_{s^{-}(1)}^+ \tau_A) \\
&= \Gamma_1^{-,t^{-}(1)} S(\partial_{i_{s^{-}(1)}}^- \partial_{s^{-}(1)}^+ \tau_A) \\
&= \Gamma_1^{-,t^{-}(1)} S(\partial_{t^{-}(1)}^+ \partial_i^- \tau_A) \\
&= \Gamma_1^{-,t^{-}(1)} S(\partial_{t^{-}(1)}^+ \tau_{\partial_{i-1}^- A})
\end{aligned}$$

So finally we have $D_{\bullet}^A = C_{\bullet}^{\partial_{i-1}^- A}$. So $\partial_i^- \mathbf{Comp}(C_{\bullet}^A) = \mathbf{Comp}(C_{\bullet}^{\partial_{i-1}^- A}) = S(\partial_{i-1}^- A)$.

Finally, let $i \neq 1$ and $\alpha = +$. For t an element of $\{-1, 0, 1\} \times \{0, 1\}^{n-1}$, let us denote by t_{+i} the element of $\{-1, 0, 1\} \times \{0, 1\}^n$ obtained by inserting a 1 in t in the i -th position. Define $D_t^A := \partial_i^+ C_{t_{+i}}^A$. Then we have:

- If $t(1) = -1$, then let $s = t_{+i}$. Then we also have $s(1) = -1$ and $s^{-}(1) = t^{-}(1)^i \cup \{i\}$. So:

$$\begin{aligned}
D_t^A &= \partial_i^+ \Gamma_1^{-,s^{-}(1)} \Gamma_1^+ S(\partial_1^- \partial_{s^{-}(1)}^+ \tau_A) \\
&= \epsilon_{t^{-}(1)} \partial_1^+ \Gamma_1^+ S(\partial_1^- \partial_{s^{-}(1)}^+ \tau_A) \\
&= \epsilon_{t^{-}(1)} S(\partial_1^- \partial_{s^{-}(1)}^+ \tau_A) \\
&= \epsilon_{t^{-}(1)} S(\partial_1^- \partial_{t^{-}(1)}^+ \partial_i^+ \tau_A)
\end{aligned}$$

In particular, if $t = (-1, 0, \dots, 0)$ then $D_t^A = S(\partial_1^- \partial_i^+ \tau_A) = S(\partial_{i-1}^+ A)$. Otherwise, if there exists j such that $t(j) = 1$ then let l such that $t = \mathbf{S}_j l$. Then $j \in t^{-}(1)$ and $D_t^A = \epsilon_j \epsilon_{l^{-}(1)_j} S(\partial_1^- \partial_{t^{-}(1)}^+ \tau_{\partial_{i-1}^- A})$. In particular $D_{\mathbf{S}_j l}^A \in \mathbf{Im}(\epsilon_j)$.

- If $t(1) \neq -1$, then let $s = t_{+i}$. Then we also have $s(1) \neq -1$ and $s^-(1) = t^-(1)^i \cup \{i\}$. So:

$$\begin{aligned}
D_t^A &= \partial_i^+ \Gamma_1^{-, s^-(1)} S(\partial_{s^-(1)}^+ \tau_A) \\
&= \epsilon_{t^-(1)} \partial_1^+ S(\partial_{s^-(1)}^+ \tau_A) \\
&= \epsilon_{t^-(1)} \mathbf{NF}(A) \\
&= \epsilon_{1, \dots, n} \hat{u}
\end{aligned}$$

In particular, if $t = \mathbf{S}_j l$ then $D_{\mathbf{S}_j l}^A \in \mathbf{Im}(\epsilon_j)$.

So we just proved that D_{\bullet}^A is a $D_{(-1, 0, \dots, 0)}^A$ -simple grid. By Proposition 5.2.2.7, $\mathbf{Comp}(D_{\bullet}^A) = D_{(-1, 0, \dots, 0)}^A = S(\partial_{i-1}^+ A)$, and finally $\partial_i^+ \mathbf{Comp}(C_{\bullet}^A) = S(\partial_{i-1}^+ A)$. \square

5.3 Construction of polygraphic resolutions and examples

In this section, we look for applications of Theorem 5.1.3.8. The main difficulty preventing us from applying this Theorem is that we need to define the map Φ on every local branching, instead of just considering critical local branchings, as is usual for Squier-like Theorems. In Section 5.3.1, we address this shortcoming by studying the simplicial monoid of local branchings. The main result is that (under very mild assumptions) local branchings form a free simplicial monoid, with generators given by the critical branchings. This means that we actually only need to define the map Φ on critical branchings.

Armed with this result, we then proceed to give an explicit description of the reduced standard presentation of a monoid M in Section 5.3.2. As it turns out, the main difficulty lies in proving that the structure we define is indeed a Gray polygraph. Once this is done, very little work is needed to prove that it satisfies the hypotheses of Theorem 5.1.3.8. Finally, in Section 5.3.3, we prove an Extended Existence Theorem similar to 1.5.2.3 in our setting.

5.3.1 Critical branchings

Notation 5.3.1.1. Let Σ be a Gray 1-polygraph. For any local n -branchings \bar{f} and \bar{g} , we write $\bar{f} \equiv \bar{g}$ if \bar{f} and \bar{g} are equal up to action of the symmetric group.

Definition 5.3.1.2. Let Σ be a Gray 1-polygraph, and let \bar{f} be a local n -branching. We say that \bar{f} is an *aspherical* branching if $\bar{f} \equiv \epsilon_i \bar{g}$, for some local $(n-1)$ -branching g .

We say that a non-aspherical branching \bar{f} is a *critical branching* if $\bar{f} \neq 1$ and for any factorisation $\bar{f} \equiv \bar{g} \otimes \bar{h}$, $\bar{g} = 1$ or $\bar{h} = 1$.

Example 5.3.1.3. For any Gray 1-polygraph Σ , we always have that the critical 0-branchings correspond to the elements of Σ_0 , while the critical 1-branchings correspond to the elements of Σ_1 .

Definition 5.3.1.4. We define a simplicial monoid $\bar{\mathbb{N}}$ as follows:

- For all $n \geq 0$, $\bar{\mathbb{N}}_n = \mathbb{N}^n$.
- Given an n -tuple $s \in \bar{\mathbb{N}}_n$, and $1 \leq i \leq n$, $\partial_i s$ is given by deleting the i -th entry of s .
- Given an n -tuple $s \in \bar{\mathbb{N}}_n$, and $1 \leq i \leq n$, $\epsilon_i s$ is given by duplicating the i -th entry of s .
- Given an n -tuple $s \in \bar{\mathbb{N}}_n$ and $t \in \bar{\mathbb{N}}_n$, $s \otimes t$ is the concatenation of s and t .
- Given an n -tuple $s \in \bar{\mathbb{N}}_n$, and $1 \leq i < n$, $\tau_i s$ is given by permuting the entries in position i and $i+1$ of s .

Lemma 5.3.1.5. Let $s \in \bar{\mathbb{N}}^n$ be a non-decreasing sequence of natural numbers of length $n \geq 0$, and let σ and τ be permutations such that for all $1 \leq i \leq n$. Suppose that σ (resp. τ) satisfies the property: for all $1 \leq i \leq n$, if $s_i = s_{i+1}$ then $\sigma \cdot i < \sigma \cdot (i+1)$ (resp. $\tau \cdot i < \tau \cdot (i+1)$).

Then if $\sigma s = \tau s$, $\sigma = \tau$.

Proof. The equivalence relation defined by $i \equiv j$ if $s_i = s_j$ induces a partition of $\{1, \dots, n\}$. Let I be an element of this partition. Let us show that σ and τ coincide on I . Let i be the value of s on I , and let J be the set of indices at which i appears in $\sigma s = \tau t$. Both σ and τ induce bijections from I to J , and by hypothesis they are even order-preserving maps. But there is at most one isomorphism of finite totally ordered sets, so σ and τ coincide on I . Since this is true for any element of our chosen partition of $\{1, \dots, n\}$, $\sigma = \tau$. \square

Lemma 5.3.1.6. Let $s = (1, \dots, n) \in \bar{\mathbb{N}}_n$ for some $n \geq 0$. Let $m \geq 0$ and let $1 \leq j_1 < \dots < j_m < n + m$. Let $t = \epsilon_{j_m} \dots \epsilon_{j_1} s$. Let $1 \leq k \leq n + m$. Then $t_k = t_{k+1}$ if and only if $k \in \{j_1, \dots, j_m\}$.

Proof. We reason by induction on m . For $m = 0$, there does not exist $k \in u$ such that $u_k = u_{k+1}$ so the result holds. Suppose now that the property is true at rank m , and let $t = \epsilon_{j_{m+1}} \dots \epsilon_{j_1} s$, and let $t' = \epsilon_{j_m} \dots \epsilon_{j_1} s$. Let $I = \{1 \leq k \leq n + m + 1 | t_k = t_{k+1}\}$, and $I' = \{1 \leq k \leq n + m + 1 | t'_k = t'_{k+1}\}$. Using the induction hypothesis, $I = \{j_1, \dots, j_m\}$ and in particular all the elements of I' are strictly smaller than j_{m+1} . Since $\epsilon_{j_{m+1}}$ consists in duplicating the j_{m+1} -th entry of t' , $I = I' \cup \{j_{m+1}\} = \{j_1, \dots, j_{m+1}\}$. \square

Definition 5.3.1.7. Let $n > 0$, and let \mathbf{j} be a subset of $\{1, \dots, n - 1\}$. We denote by $S_n(\mathbf{j})$ the set of all permutations $\sigma \in S_n$ such that for all $i \in \mathbf{j}$, $\sigma \cdot i < \sigma \cdot (i + 1)$.

Unfolding the definition of a simplicial monoid, we get that a simplicial monoid is the data of:

- A family of sets C_n , for $n \geq 0$.
- For any $n > 0$ and any $1 \leq i \leq n$ applications $\partial_i : C_n \rightarrow C_{n+1}$ and $\epsilon_i : C_n \rightarrow C_{n+1}$.
- For any $n, m \geq 0$ an application $\otimes : C_n \times C_m \rightarrow C_{n+m}$.
- For any $n > 0$ and any $1 \leq i < n$, an application $\tau_i : C_n \rightarrow C_n$.

This data has to verify some axioms. In particular the axioms that do not involve the operations ∂_i are the following:

$$\epsilon_i \epsilon_j = \begin{cases} \epsilon_{j^i} \epsilon_i & i < j \\ \epsilon_i \epsilon_i & i = j \end{cases} \quad (5.3.1) \quad \begin{cases} (\epsilon_i _ \otimes _) = \epsilon_i(_ \otimes _) \\ (_ \otimes \epsilon_i _) = \epsilon_{n+i}(_ \otimes _) \end{cases} \quad (5.3.5)$$

$$\begin{cases} t_i t_j = t_j t_i & |i_j| > 2 \\ t_i t_{i+1} t_i = t_{i+1} t_i t_{i+1} \\ t_i t_i = 1 \end{cases} \quad (5.3.2) \quad \epsilon_i \tau_j = \begin{cases} \tau_{j+1} \epsilon_i & i < j \\ \tau_{j+1} \tau_j \epsilon_{j+1} & i = j \\ \tau_j \tau_{j+1} \epsilon_j & i = j + 1 \\ \tau_j \epsilon_i & i > j + 1 \end{cases} \quad (5.3.6)$$

$$(_ \otimes (_ \otimes _)) = ((_ \otimes _) \otimes _) \quad (5.3.3)$$

$$\begin{cases} (t_i _ \otimes _) = t_i(_ \otimes _) \\ (_ \otimes t_i _) = t_{n+i}(_ \otimes _) \end{cases} \quad (5.3.4) \quad \tau_i \epsilon_i = 1 \quad (5.3.7)$$

We prove the following Proposition about simplicial monoids:

Proposition 5.3.1.8. Let C be a simplicial monoid, and let $f : C_{i_1} \times \dots \times C_{i_{m+1}} \rightarrow C_p$ be a formal composite of applications ϵ_i , τ_i and \otimes subject to the relations (5.3.1) to (5.3.7), where m, p and i_1, \dots, i_{m+1} are integers. Then there exists a unique integer n and a unique family of integers $1 \leq j_1 < \dots < j_n < p$ and a unique factorisation of f :

$$f = \sigma \epsilon_{j_n} \dots \epsilon_{j_1} (\dots (_ \otimes _) \dots \otimes _)$$

such that:

- $p = i_1 + \dots + i_{m+1} + n$.
- $\sigma \in S_p(\mathbf{j})$, with $\mathbf{j} = \{j_1, \dots, j_n\}$.

Proof. For the existence, consider that it is possible to pass all \otimes to the right using Equations (5.3.4) and (5.3.5), and then all the transpositions t_i on the left using Equation (5.3.6). Finally, the operations \otimes can be rearranged using the associativity, and the operations ϵ_i using Equation (5.3.1). It remains to show that we can choose σ to be in $S_p(\mathbf{j})$.

Suppose that we have a factorisation of f that does not verify this property. Let J be the set of all $j \in \mathbf{j}$ such that $\sigma \cdot j > \sigma \cdot (j + 1)$, and let k such that j_k is the minimum of J . Let $\sigma' = \sigma \cdot \tau_{j_k}$ and let us show that $\sigma' \epsilon_{j_n} \dots \epsilon_{j_1} = \sigma \epsilon_{j_m} \dots \epsilon_{j_1}$. We distinguish two cases:

- If $j_k + 1 = j_{k+1}$. Using Equation (5.3.6) we have:

$$\begin{aligned} \sigma' \epsilon_{j_n} \dots \epsilon_{j_1} &= \sigma \epsilon_{j_n} \dots \epsilon_{j_{k+2}} \tau_{j_k} \epsilon_{j_{k+1}} \epsilon_{j_k} \dots \epsilon_{j_1} \\ &= \sigma \epsilon_{j_n} \dots \epsilon_{j_{k+2}} \tau_{j_k} \epsilon_{j_k} \epsilon_{j_k} \dots \epsilon_{j_1} \\ &= \sigma \epsilon_{j_n} \dots \epsilon_{j_{k+2}} \epsilon_{j_k} \epsilon_{j_k} \dots \epsilon_{j_1} \\ &= \sigma \epsilon_{j_n} \dots \epsilon_{j_{k+2}} \epsilon_{j_{k+1}} \epsilon_{j_k} \dots \epsilon_{j_1} \end{aligned}$$

- Otherwise, then

$$\begin{aligned} \sigma' \epsilon_{j_n} \dots \epsilon_{j_1} &= \sigma \epsilon_{j_n} \dots \epsilon_{j_{k+1}} \tau_{j_k} \epsilon_{j_k} \dots \epsilon_{j_1} \\ &= \sigma \epsilon_{j_n} \dots \epsilon_{j_{k+1}} \epsilon_{j_k} \dots \epsilon_{j_1} \end{aligned}$$

Notice that for all $i < j_k$, $\sigma' \cdot i = \sigma \cdot i$ and that $\sigma' \cdot j_k = \sigma \cdot (j_k + 1) < \sigma \cdot j_k = \sigma' \cdot (j_k + 1)$. Let us denote by J' the set of all $j \in \mathbf{j}$ such that $\sigma' \cdot j > \sigma' \cdot (j + 1)$. We just proved that the minimum of J' is greater than that of J . By iterating this process, we progressively get rid of all the elements in J .

We now move on to the proof of the unicity. Suppose $f = \sigma' \epsilon_{j'_{n'}} \dots \epsilon_{j'_1} (\dots (_ \otimes _) \dots _)$ where n' and $1 \leq j'_1 < \dots < j'_{n'} < p$ are integers such that $p = i_1 + \dots + i_{m+1} + n'$, and $\sigma \in S_p(\mathbf{j})$, with $\mathbf{j}' = \{j'_1, \dots, j'_{n'}\}$. Note first that $n' = p - i_1 - \dots - i_{m+1} = n$.

Let now $s = (1, \dots, i_1 + \dots + i_{m+1}) \in \bar{\mathbb{N}}_{i_1 + \dots + i_{m+1}}$. Let $t = \epsilon_{j_n} \dots \epsilon_{j_1} s$ and $t' = \epsilon_{j'_{n'}} \dots \epsilon_{j'_1} s$. By definition of ϵ in \mathbb{N} , both t and t' are non-decreasing sequences of integers. Moreover, $\sigma t = \sigma' t' = f((1, \dots, i_1), (i_1 + 1, \dots, i_1 + i_2), \dots, (i_1 + \dots + i_m + 1, \dots, i_1 + \dots + i_{m+1}))$. Let $k \in \mathbb{N}$. Since the application of σ and τ does not modify the number of occurrences of k in t and t' , k appears the same number of times in t and t' . Since both t and t' non-decreasing sequences, they are equal.

So we get that $\epsilon_{j_n} \dots \epsilon_{j_1} s = \epsilon_{j'_{n'}} \dots \epsilon_{j'_1} s$. Using Lemma 5.3.1.6, $\{j_1, \dots, j_n\} = \{j'_1, \dots, j'_{n'}\}$. Since there is only one way to pick the elements of a finite set of integers in a strictly increasing fashion, $j_k = j'_k$ for all $1 \leq k \leq n$.

On the other hand, we also have that $\sigma t = \sigma' t'$. Let $1 \leq i \leq p$ such that $t_i = t_{i+1}$. By Lemma 5.3.1.6, i is in \mathbf{j} . Since $\sigma, \sigma' \in S_p(\mathbf{j})$, $\sigma \cdot i < \sigma \cdot (i + 1)$, and the same holds for σ' . So by Lemma 5.3.1.5, $\sigma = \sigma'$. \square

Definition 5.3.1.9. Let Σ be a Gray 1-polygraph. A *choice of critical branching up to permutation* is the choice, for any critical branching, of a distinguished representative up to \equiv .

Lemma 5.3.1.10. *Let Σ be a Gray 1-polygraph. Then any choice of critical branchings generates $\text{LocBr}(\Sigma)$.*

Proof. Using the action of the symmetric groups, we first get that the set of all local branchings generated by a choice of critical branchings is closed under permutation. In particular, it therefore contains all the critical branchings. Let us prove by induction on the pair (n, p) that any n -branching whose source is of length p is generated by the critical branchings.

If $n = 0$ then this corresponds to saying that $\Sigma_0^{G(0)}$ is generated by Σ_0 as a monoid. Take now any \bar{f} an n -branching whose source is of length p . If $\bar{f} \equiv \epsilon_i \bar{g}$, then \bar{g} is an $(n-1)$ -branching and by induction hypothesis, \bar{g} is generated by the critical branchings, and so is \bar{f} .

Otherwise, then either \bar{f} is a critical branching and so the result holds, or we can write $\bar{f} \equiv \bar{g} \otimes \bar{h}$, with $\bar{g} \neq 1$ and $\bar{h} \neq 1$. The only case where we cannot apply the induction hypothesis to conclude is if \bar{g} (resp. \bar{h}) is also an n -branching with source of length p . But then \bar{h} (resp. \bar{g}) has to be a 0-branching with source of length 0, that is $\bar{h} = 1$ (resp. $\bar{h} = 1$), but this contradicts the hypothesis on \bar{h} (resp. \bar{g}). \square

Definition 5.3.1.11. Let Σ be a Gray 1-polygraph, and let f be a rewriting step. Then f can be factored uniquely as ugv , with $u, v \in \Sigma_0^{G(0)}$ and $g \in \Sigma_1$. We call u (resp. v) the *left-whisker* (resp. *right-whisker* of g , and denote it by $\mathbf{lw}(f)$ (resp. $\mathbf{rw}(f)$).

Lemma 5.3.1.12. Let Σ be a Gray 1-polygraph, and suppose that for all $f \in \Sigma_1$, $\mathbf{s}(f) \neq 1$. Let $\bar{f}^1, \dots, \bar{f}^n$ be distinguished critical branchings, and $\bar{h} = \bar{f}^1 \otimes \dots \otimes \bar{f}^n \in \mathbf{LocBr}(\Sigma)_p$, for some $p \geq 1$. Let us write $\bar{h} = (h_1, \dots, h_p)$.

Then for any $1 \leq i \neq j \leq p$, $h_i \neq h_j$.

Proof. Let j_1, \dots, j_n such that for all $1 \leq i \leq n$, $\bar{f}^i \in \mathbf{LocBr}(\Sigma)_{j_i}$, and let $\bar{h} = (h_1, \dots, h_p)$, where each h_i is a rewriting step. For any $1 \leq i \leq p$, let us denote by $u(i)$ and $v(i)$ the unique integers such that $1 \leq v(i) \leq j_{u(i)}$ and $i = j_1 + \dots + j_{u(i)-1} + v(i)$. Then by definition of the product:

$$h_i = \mathbf{s}(\bar{f}^1) \dots \mathbf{s}(\bar{f}^{u(i)-1}) \bar{f}_{v(i)}^{u(i)} \mathbf{s}(\bar{f}^{u(i)+1}) \dots \mathbf{s}(\bar{f}^n)$$

Let now $1 \leq i \neq j \leq p$, and let us show that $h_i \neq h_j$.

- If $u(i) = u(j)$, then there exists $x, y \in \Sigma^{G(1)}$ such that $h_i = x \bar{f}_{v(i)}^{u(i)} y$ and $h_j = x \bar{f}_{v(j)}^{u(i)} y$. Since $\bar{f}^{u(i)}$ is not an aspherical branching, $\bar{f}_{v(i)}^{u(i)} \neq \bar{f}_{v(j)}^{u(i)}$ and so $h_i \neq h_j$.
- Otherwise, suppose without loss of generality that $i < j$. Then there exists $x, y, z \in \Sigma_0^{G(0)}$ such that:

$$h_i = x \bar{f}_{v(i)}^{u(i)} y \mathbf{s}(f^{u(j)}) z \quad h_j = x \mathbf{s}(\bar{f}_{v(i)}^{u(i)}) y \bar{f}_{v(j)}^{u(j)} z$$

Then in particular $\mathbf{lw}(h_i) = x \mathbf{lw}(\bar{f}_{v(i)}^{u(i)})$ and $\mathbf{lw}(h_j) = x \mathbf{s}(\bar{f}_{v(i)}^{u(i)}) y \mathbf{lw}(\bar{f}_{v(j)}^{u(j)})$. But the hypothesis on the source of the branchings implies that $l(\mathbf{s}(\bar{f}_{v(i)}^{u(i)})) > l(\mathbf{lw}(\bar{f}_{v(j)}^{u(j)}))$. So as a consequence, $l(\mathbf{lw}(h_i)) < l(\mathbf{lw}(h_j))$, and so $h_i \neq h_j$. \square

Lemma 5.3.1.13. Let Σ be a Gray 1-polygraph, and suppose that for all $f \in \Sigma_1$, $\mathbf{s}(f) \neq 1$. Let $\bar{f}^1, \dots, \bar{f}^n$ and $\bar{g}^1, \dots, \bar{g}^m$ be families of distinguished critical branchings. If $\sigma \cdot \bar{f}^1 \otimes \dots \otimes \bar{f}^n = \tau \cdot (\bar{g}^1 \otimes \dots \otimes \bar{g}^m)$, for some $\sigma, \tau \in S_p$, then $n = m$, $\sigma = \tau$ and for all $1 \leq i \leq n$, $\bar{f}^i = \bar{g}^i$.

Proof. First we prove, that for all $1 \leq i \leq n$, $\mathbf{s}(\bar{f}^i) = \mathbf{s}(\bar{g}^i)$. Indeed, otherwise, let i minimal such that $\mathbf{s}(\bar{f}^i) \neq \mathbf{s}(\bar{g}^i)$. Note first that necessarily $m \geq i$, so that \bar{g}^i is well-defined. Indeed, if $m = i - 1$ the hypothesis on the source of the rewriting steps gives us that $l(\mathbf{s}(\bar{f}^i)) > 0$ and so we get the following contradiction (where $u = \mathbf{s}(\bar{f}^1) \dots \mathbf{s}(\bar{f}^n)$):

$$l(u) = l(\mathbf{s}(\bar{f}^1) \dots \mathbf{s}(\bar{f}^n)) \geq l(\mathbf{s}(\bar{f}^1) \dots \mathbf{s}(\bar{f}^i)) > l(\mathbf{s}(\bar{f}^1) \dots \mathbf{s}(\bar{f}^{i-1})) = l(\mathbf{s}(\bar{g}^1) \dots \mathbf{s}(\bar{g}^{i-1})) = l(u).$$

Moreover, the fact that i is minimal implies that $l(\bar{f}^i) \neq l(\bar{g}^i)$. Without loss of generality, suppose that $l(\mathbf{s}(\bar{f}^i)) < l(\mathbf{s}(\bar{g}^i))$, such that $\mathbf{s}(\bar{g}^i) = \mathbf{s}(\bar{f}^i)v$ for some $v \in \Sigma_0^{G(1)}$, $v \neq 1$. Note that

in particular $l(s(\bar{g}^i)) > 1$, so that \bar{g}^i is not a 0-branching. Let $j > 0$ such that $\bar{g}^i = (g_1^i, \dots, g_j^i)$. Let j_1, \dots, j_n such that for all $1 \leq k \leq n$, $\bar{f}^k \in \mathbf{LocBr}(\Sigma)_{j_k}$, and let $\bar{h} = \sigma \cdot (\bar{f}^1 \otimes \dots \otimes \bar{f}^n) = (h_1, \dots, h_p)$, where each h_k is a rewriting step. For any $1 \leq k \leq p$, by the definition of the product, there exist integers $u(k)$ and $v(k)$ such that

$$h_k = s(\bar{f}^1) \dots s(\bar{f}^{u(k)-1}) \bar{f}_{v(k)}^{u(k)} s(\bar{f}^{u(k)+1}) \dots s(\bar{f}^n)$$

Moreover, using the hypothesis on the source of the rewriting steps, $u(k)$ is completely characterised by the fact that $l(s(\bar{f}^1)) + \dots + l(s(\bar{f}^{u(k)-1})) \leq l(\mathbf{lw}(h_k)) < l(s(\bar{f}^1)) + \dots + l(s(\bar{f}^{u(k)}))$. So $u(k)$ is uniquely determined. And since $\bar{f}^{u(k)}$ is not aspherical, so is $v(k)$. Let $1 \leq k \leq j$. There exists k' such that $s(\bar{g}^1) \dots s(\bar{g}^{i-1}) g_k^i s(\bar{g}^i) \dots s(\bar{g}^m) = x g_{k'}^i y = h_{k'}$, with $x, y \in \Sigma_0^{G(1)}$. Then two cases are possible:

- If $u(k') = i$. Then $h_{k'} = s(\bar{g}^1) \dots s(\bar{g}^{i-1}) g' s(\bar{f}^{i+1}) \dots s(\bar{f}^n) = x g' v z$, with $z \in \Sigma_0^{G(0)}$ and g' a rewriting step. So $g_k^i = g' v$ and $y = v z$.
- Otherwise, then $u(k') > i$ and $h_{k'} = s(\bar{f}^1) \dots s(\bar{f}^{u(k')-1}) g' s(\bar{f}^{u(k')+1}) \dots s(\bar{f}^n) = x s(\bar{f}^i) z_1 g' z_2$, with $z_1, z_2 \in \Sigma_0^{G(0)}$ and g' a rewriting step. So $g_k^i = s(\bar{f}^i) z_1 g''$ for some rewriting step g'' .

In the end, any rewriting step g_k^i can be factored either in something of the form $g' v$ or in the form $s(\bar{f}^i) g'$. Since moreover $s(\bar{g}^i) = s(\bar{f}^i) v$, we get that \bar{g}^i is a Peiffer branching, which contradicts the hypothesis on \bar{g}^i . So in the end we get that $n \leq m$ and for all $1 \leq i \leq n$ $s(\bar{f}^i) = s(\bar{g}^i)$. By symmetry, we get that $n = m$.

Notice finally that because of the characterisation of $u(k)$ we gave earlier, we have that for any $1 \leq k \leq n$, there exists some (unique) $v'(k)$ such that $h_k = s(\bar{f}^1) \dots s(\bar{f}^{u(k)-1}) g_{v'(k)}^{u(k)} s(\bar{f}^{u(k)+1}) \dots s(\bar{f}^n)$. As a consequence, we get that for all $1 \leq k \leq n$, $\{f_1^k, \dots, f_{j_k}^k\} = \{g_1^k, \dots, g_{j_k}^k\}$. So $\bar{g}^i \equiv \bar{f}^i$, but since they are both distinguished critical branchings, $\bar{f}^i = \bar{g}^i$. Finally, because of Lemma 5.3.1.12, for any $i \neq j$ $h_i \neq h_j$, and so $\sigma = \tau$. \square

Theorem 5.3.1.14. *Let Σ be a monoidal 1-polygraph, and suppose that for all $f \in \Sigma_1$, $\mathbf{s}(f) \neq 1$. Then $\mathbf{LocBr}(\Sigma)$ is freely generated by any choice of critical branchings up to permutation.*

Proof. We already know from Lemma 5.3.1.10 that $\mathbf{LocBr}(\Sigma)$ is generated by any choice of critical branchings. Using Proposition 5.3.1.8, we need to show that for any p -branching \bar{f} , there exists a unique $m \in \mathbb{N}$, a unique sequence of integers i_1, \dots, i_{m+1} , a unique family of distinguished critical branchings $\bar{f}^1, \dots, \bar{f}^{m+1}$, with $\bar{f}^k \in \mathbf{LocBr}(\Sigma)_k$, unique integers n and $1 \leq j_1 < \dots < j_n < p$ and a unique $\sigma \in S_p$ such that:

$$\bar{f} = \sigma \cdot \epsilon_{j_n} \dots \epsilon_{j_1} (\bar{f}^1 \otimes \dots \otimes \bar{f}^{m+1}).$$

Together with $p = i_1 + \dots + i_{m+1} + n$ and $\sigma \in S_p(\mathbf{j})$, where $\mathbf{j} = \{j_1, \dots, j_n\}$. Let us suppose that we have a second such decomposition $\bar{f} = \sigma' \cdot \epsilon_{j'_n} \dots \epsilon_{j'_1} (\bar{f}^{1'} \otimes \dots \otimes \bar{f}^{m'+1})$, and let us show that they are equal.

Note first that by definition of the operations ϵ_i and of the action of σ , we have equalities that the set of rewriting steps appearing in \bar{f} is the same as the set of rewriting steps appearing in $\bar{f}^1 \otimes \dots \otimes \bar{f}^{m+1}$, and symmetrically as the set of branchings appearing in $\bar{f}^{1'} \otimes \dots \otimes \bar{f}^{m'+1}$. Since all the rewriting steps appearing in $\bar{f}^1 \otimes \dots \otimes \bar{f}^{m+1}$ or $\bar{f}^{1'} \otimes \dots \otimes \bar{f}^{m'+1}$ are distinct (Lemma 5.3.1.12), there exists a permutation τ such that $\bar{f}^1 \otimes \dots \otimes \bar{f}^{m+1} = \tau \cdot (\bar{f}^{1'} \otimes \dots \otimes \bar{f}^{m'+1})$. By Lemma 5.3.1.13, we get that $\tau = 1$, $m' = m$ and for all $1 \leq i \leq m+1$, $\bar{f}^i = \bar{f}^{i'}$.

The proof of the uniqueness of the j_k and of σ is similar to the one in the proof of Proposition 5.3.1.8, using the fact that all the rewriting steps appearing are distinct. \square

Remark 5.3.1.15. The condition that for all $f \in \Sigma_1$, $\mathbf{s}(f) \neq 1$ is really necessary. Indeed, if f is such an rewriting step, then we have $\epsilon_1 f = (f, f) = f \otimes f$. This condition however is very mild since we are interested in terminating polygraphs, which will all verify this condition.

Definition 5.3.1.16. A *good choice of critical branching* is a choice of critical branchings such that for all distinguished critical n -branching \bar{f} and all $1 \leq i \leq n$, there exists distinguished critical branchings $\bar{f}^1, \dots, \bar{f}^p$ such that $\partial_i \bar{f} = \bar{f}^1 \otimes \dots \otimes \bar{f}^p$.

Lemma 5.3.1.17. *Let Σ be a Gray 1-polygraph such that for all $f \in \Sigma_1$, $\mathbf{s}(f) \neq 1$. There exists a good choice of critical branchings in $\mathbf{LocBr}(\Sigma)$.*

Proof. For $n = 0$, critical 0-branchings correspond to the elements of Σ_0 . The equivalence classes are trivial, so we choose all of those as distinguished ones. For $n = 1$ the critical 1-branchings are the elements of Σ_1 , and once again the equivalence classes are trivial. The condition that there exists distinguished critical 0-branchings $\bar{f}^1, \dots, \bar{f}^p$ such that $\partial_1 \bar{f} = \bar{f}^1 \otimes \dots \otimes \bar{f}^p$ correspond to the fact that $\partial_1 \bar{f}$ is a word on Σ_0 .

We now order rewriting steps by saying that for all $f, g \in \Sigma_1$ and all $x, y, z \in \Sigma_0^{G(1)}$, $xfys(g)z < xs(f)ygz$. Note that in particular this is anti-reflexive because if $xfys(f)z < xs(f)yfz$ then in particular $x = xs(f)y$ and so $\mathbf{s}(f) = 1$, which is impossible by hypothesis. Let us now choose a completion of $<$ into a total ordering on rewriting steps. We say that a non-aspherical branching \bar{f} is well-ordered if for any $i < j$, $f_i < f_j$. In particular if \bar{f}^1 and \bar{f}^2 are well-ordered, then so is $\bar{f}^1 \otimes \bar{f}^2$. Define the distinguished critical branchings as the well-ordered ones, and let us show that this is a good choice of critical branchings. First because the order is total it is a choice of critical branchings.

Next we reason inductively on n to show that for any $1 \leq i \leq n$, and any n -branching \bar{f} , $\partial_i \bar{f}$ is of the required form. Since a choice of critical branchings freely generate all branchings we know that we can write $\partial_i \bar{f} = \sigma \cdot \epsilon_{j_p} \dots \epsilon_1 (\bar{f}^1 \otimes \dots \otimes \bar{f}^m)$, with \bar{f}^k all distinguished critical branchings. Since \bar{f} is a critical branching, no rewriting step appears twice in \bar{f} and in particular this also holds for $\partial_i \bar{f}$. So $p = 0$ and $\partial_i \bar{f} = \sigma \cdot (\bar{f}^1 \otimes \dots \otimes \bar{f}^m)$. Since all the \bar{f}^i are well-ordered, so is $\bar{f}^1 \otimes \dots \otimes \bar{f}^m$, and so is $\partial_i \bar{f}$ (because \bar{f} was). But then the only permutation that respects the order is $\sigma = 1$.

□

Note that the proof of Lemma 5.3.1.17 actually proves the following:

Proposition 5.3.1.18. *Let Σ be a Gray 1-polygraph such that for all $f \in \Sigma_1$, $\mathbf{s}(f) \neq 1$, and let $<$ be a total ordering on rewriting steps such that for all $f, g \in \Sigma_1$ and all $x, y, z \in \Sigma_0^{G(1)}$, $xfys(g)z < xs(f)ygz$*

Define a non-aspherical branching $\bar{f} = (f_1, \dots, f_n)$ to be well-ordered if for all $i < j$, $f_i < f_j$, and define the distinguished critical branchings as the well-ordered ones.

This defines a good choice of critical branchings in $\mathbf{LocBr}(\Sigma)$.

Remark 5.3.1.19. In particular, if Σ is a *reduced* Gray 1-polygraph, then the *left-most* ordering on rewriting steps satisfies the hypothesis of Proposition 5.3.1.18. The left-most ordering is defined by: for all rewriting steps f and g of same source, $f < g$ if $l(\mathbf{lw}(f)) < l(\mathbf{lw}(g))$.

5.3.2 The reduced standard resolution of a monoid

In this section, we give an explicit description of the reduced standard resolution of a monoid M . In order to clarify notations, we reserve juxtaposition to denote the multiplication in M . Product in the free Gray-monoid will be denoted by \otimes .

Definition 5.3.2.1. Let M be a monoid. We define a Gray $(\omega, 1)$ -polygraph $\mathbf{RStd}(M)$ as follows:

- For any $n \geq 0$, $\mathbf{RStd}(M)_n$ consists of $(n+1)$ -tuples (m_1, \dots, m_{n+1}) of elements of $M \setminus \{1\}$, that we denote $(m_1 | \dots | m_{n+1})$.
- The faces are given for $1 \leq i \leq n$ by:

$$\partial_i^-(m_1 | \dots | m_{n+1}) = (m_1 | \dots | m_i) \otimes (m_{i+1} | \dots | m_{n+1})$$

$$\partial_i^+(m_1 | \dots | m_{n+1}) = \begin{cases} (m_1 | \dots | m_i m_{i+1} | m_{i+2} | \dots | m_{n+1}) & m_i m_{i+1} \neq 1 \\ \epsilon_1(m_3 | \dots | m_{n+1}) & i = 1 \text{ and } m_1 m_2 = 1 \\ \Gamma_{i-1}^+(m_1 | \dots | m_{i-1} | m_{i+2} | \dots | m_{n+1}) & 2 \leq i \leq n-1 \text{ and } m_i m_{i+1} = 1 \\ \epsilon_{n-1}(m_1 | \dots | m_{n-1}) & i = n \text{ and } m_n m_{n+1} = 1 \end{cases}$$

with $\partial_1^+(m_1 | m_2) = 1$ (the unit of the Gray monoid $\mathbf{RStd}(M)$) if $m_1 m_2 = 1$ (the unit of the monoid M).

Proof. Let us prove that $\mathbf{RStd}(M)$ does indeed form a Gray $(\omega, 1)$ -polygraph. Indeed, we have, for $j > i$:

$$\begin{aligned} \partial_{j-1}^- \partial_i^-(m_1 | \dots | m_{n+1}) &= \partial_{j-1}^-(m_1 | \dots | m_i) \otimes (m_{i+1} | \dots | m_{n+1}) \\ &= (m_1 | \dots | m_i) \otimes (m_{i+1} | \dots | m_j) \otimes (m_{j+1} | \dots | m_{n+1}) \\ &= \partial_i^-(m_1 | \dots | m_j) \otimes (m_{j+1} | \dots | m_{n+1}) \\ &= \partial_i^- \partial_j^-(m_1 | \dots | m_{n+1}) \end{aligned}$$

If $m_j m_{j+1} \neq 1$:

$$\begin{aligned} \partial_{j-1}^+ \partial_i^-(m_1 | \dots | m_{n+1}) &= \partial_{j-1}^+(m_1 | \dots | m_i) \otimes (m_{i+1} | \dots | m_{n+1}) \\ &= (m_1 | \dots | m_i) \otimes (m_{i+1} | \dots | m_j m_{j+1} | m_{j+2} | \dots | m_{n+1}) \\ &= \partial_i^-(m_1 | \dots | m_j m_{j+1} | m_{j+2} | \dots | m_{n+1}) \\ &= \partial_i^- \partial_j^+(m_1 | \dots | m_{n+1}) \end{aligned}$$

If $m_j m_{j+1} = 1$ and $j = i + 1$:

$$\begin{aligned} \partial_i^+ \partial_i^-(m_1 | \dots | m_{n+1}) &= \partial_i^+(m_1 | \dots | m_i) \otimes (m_{i+1} | \dots | m_{n+1}) \\ &= (m_1 | \dots | m_i) \otimes \partial_1^+(m_{i+1} | \dots | m_{n+1}) \\ &= (m_1 | \dots | m_i) \otimes \epsilon_1(m_{i+3} | \dots | m_{n+1}) \\ &= \epsilon_i(m_1 | \dots | m_i) \otimes (m_{i+3} | \dots | m_{n+1}) \\ &= \epsilon_i \partial_i^-(m_1 | \dots | m_i | m_{i+3} | \dots | m_{n+1}) \\ &= \partial_i^- \Gamma_i^+(m_1 | \dots | m_i | m_{i+3} | \dots | m_{n+1}) \\ &= \partial_i^- \partial_{i+1}^+(m_1 | \dots | m_{n+1}) \end{aligned}$$

If $m_j m_{j+1} = 1$ and $i + 2 \leq j \leq n - 1$:

$$\begin{aligned}
\partial_{j-1}^+ \partial_i^- (m_1 | \dots | m_{n+1}) &= \partial_{j-1}^+ (m_1 | \dots | m_i) \otimes (m_{i+1} | \dots | m_{n+1}) \\
&= (m_1 | \dots | m_i) \otimes \partial_{j-i}^- (m_{i+1} | \dots | m_{n+1}) \\
&= (m_1 | \dots | m_i) \otimes \Gamma_{j-i-1}^+ (m_{i+1} | \dots | m_{j-1} | m_{j+2} | \dots | m_n) \\
&= \Gamma_{j-1}^+ ((m_1 | \dots | m_i) \otimes (m_{i+1} | \dots | m_{j-1} | m_{j+2} | \dots | m_n)) \\
&= \Gamma_{j-1}^+ \partial_i^- (m_1 | \dots | m_{j-1} | m_{j+2} | \dots | m_n) \\
&= \partial_i^- \Gamma_j^+ (m_1 | \dots | m_{j-1} | m_{j+2} | \dots | m_n) \\
&= \partial_i^- \partial_{j+1}^+ (m_1 | \dots | m_n)
\end{aligned}$$

If $m_j m_{j+1} = 1$ and $j = n$:

$$\begin{aligned}
\partial_{n-1}^+ \partial_i^- (m_1 | \dots | m_{n+1}) &= \partial_{n-1}^+ (m_1 | \dots | m_i) \otimes (m_{i+1} | \dots | m_{n+1}) \\
&= (m_1 | \dots | m_i) \otimes \partial_{n-i}^+ (m_{i+1} | \dots | m_{n+1}) \\
&= (m_1 | \dots | m_i) \otimes \epsilon_{n-i-1} (m_{i+1} | \dots | m_{n-1}) \\
&= \epsilon_{n-2} (m_1 | \dots | m_i) \otimes (m_{i+1} | \dots | m_{n-1}) \\
&= \epsilon_{n-2} \partial_i^- (m_1 | \dots | m_{n-1}) \\
&= \partial_i^- \epsilon_{n-1} (m_1 | \dots | m_{n-1}) \\
&= \partial_i^- \partial_n^+ (m_1 | \dots | m_{n+1})
\end{aligned}$$

If $m_i m_{i+1} \neq 1$:

$$\begin{aligned}
\partial_{j-1}^- \partial_i^+ (m_1 | \dots | m_{n+1}) &= \partial_{j-1}^- (m_1 | \dots | m_i m_{i+1} | m_{i+2} | \dots | m_{n+1}) \\
&= (m_1 | \dots | m_i m_{i+1} | m_{i+2} | \dots | m_j) \otimes (m_{j+1} | \dots | m_{n+1}) \\
&= \partial_i^+ (m_1 | \dots | m_i | m_{i+1} | m_{i+2} | \dots | m_j) \otimes (m_{j+1} | \dots | m_{n+1}) \\
&= \partial_i^+ \partial_j^- (m_1 | \dots | m_{n+1})
\end{aligned}$$

If $m_i m_{i+1} = 1$ and $i = 1$ and $j = 2$:

$$\begin{aligned}
\partial_1^- \partial_1^+ (m_1 | \dots | m_{n+1}) &= \partial_1^- \epsilon_1 (m_3 | \dots | m_{n+1}) \\
&= (m_3 | \dots | m_{n+1}) \\
&= \partial_1^+ (m_1 | m_2) \otimes (m_3 | \dots | m_{n+1}) \\
&= \partial_1^+ \partial_2^- (m_1 | \dots | m_{n+1})
\end{aligned}$$

If $m_i m_{i+1} = 1$ and $i = 1$ and $j > 2$:

$$\begin{aligned}
\partial_{j-1}^- \partial_1^+ (m_1 | \dots | m_{n+1}) &= \partial_{j-1}^- \epsilon_1 (m_3 | \dots | m_{n+1}) \\
&= \epsilon_1 \partial_{j-2}^- (m_3 | \dots | m_{n+1}) \\
&= \epsilon_1 ((m_3 | \dots | m_j) \otimes (m_{j+1} | \dots | m_{n+1})) \\
&= (\epsilon_1 (m_3 | \dots | m_j)) \otimes (m_{j+1} | \dots | m_{n+1}) \\
&= (\partial_1^+ (m_1 | \dots | m_j)) \otimes (m_{j+1} | \dots | m_{n+1}) \\
&= \partial_1^+ ((m_1 | \dots | m_j) \otimes (m_{j+1} | \dots | m_{n+1})) \\
&= \partial_1^+ \partial_j^- (m_1 | \dots | m_{n+1})
\end{aligned}$$

If $m_i m_{i+1} = 1$ and $2 \leq i \leq n-1$ and $j = i+1$

$$\begin{aligned}
\partial_i^- \partial_i^+ (m_1 | \dots | m_{n+1}) &= \partial_i^- \Gamma_{i-1}^+ (m_1 | \dots | m_{i-1} | m_{i+2} | \dots | m_{n+1}) \\
&= \epsilon_{i-1} \partial_{i-1}^- (m_1 | \dots | m_{i-1} | m_{i+2} | \dots | m_{n+1}) \\
&= \epsilon_{i-1} (m_1 | \dots | m_{i-1}) \otimes (m_{i+2} | \dots | m_{n+1}) \\
&= \partial_i^+ (m_1 | \dots | m_{i+1}) \otimes (m_{i+2} | \dots | m_{n+1}) \\
&= \partial_i^+ \partial_{i+1}^- (m_1 | \dots | m_{n+1})
\end{aligned}$$

If $m_i m_{i+1} = 1$ and $2 \leq i \leq n-1$ and $j \geq i+2$

$$\begin{aligned}
\partial_{j-1}^- \partial_i^+ (m_1 | \dots | m_{n+1}) &= \partial_{j-1}^- \Gamma_{i-1}^+ (m_1 | \dots | m_{i-1} | m_{i+2} | \dots | m_{n+1}) \\
&= \Gamma_{i-1}^+ \partial_{j-2}^- (m_1 | \dots | m_{i-1} | m_{i+2} | \dots | m_{n+1}) \\
&= \Gamma_{i-1}^+ (m_1 | \dots | m_{i-1} | m_{i+2} | \dots | m_j) \otimes (m_{j+1} | \dots | m_{n+1}) \\
&= \partial_i^+ (m_1 | \dots | m_j) \otimes (m_{j+1} | \dots | m_{n+1}) \\
&= \partial_i^+ \partial_j^- (m_1 | \dots | m_{n+1})
\end{aligned}$$

If $m_i m_{i+1} \neq 1$ and $m_j m_{j+1} \neq 1$ and $j = i+1$:

$$\begin{aligned}
\partial_i^+ \partial_i^+ (m_1 | \dots | m_{n+1}) &= \partial_i^+ (m_1 | \dots | m_{i-1} | m_i m_{i+1} | m_{i+2} | \dots | m_{n+1}) \\
&= (m_1 | \dots | m_{i-1} | m_i m_{i+1} m_{i+2} | m_{i+3} | \dots | m_{n+1}) \\
&= \partial_i^+ (m_1 | \dots | m_i | m_{i+1} m_{i+2} | m_{i+3} | \dots | m_{n+1}) \\
&= \partial_i^+ \partial_{i+1}^+ (m_1 | \dots | m_{n+1})
\end{aligned}$$

If $m_i m_{i+1} \neq 1$ and $m_j m_{j+1} \neq 1$ and $j > i+1$:

$$\begin{aligned}
\partial_{j-1}^+ \partial_i^+ (m_1 | \dots | m_{n+1}) &= \partial_{j-1}^+ (m_1 | \dots | m_{i-1} | m_i m_{i+1} | m_{i+2} | \dots | m_{n+1}) \\
&= (m_1 | \dots | m_{i-1} | m_i m_{i+1} | m_{i+2} | \dots | m_{j-1} | m_j m_{j+1} | m_{j+2} | \dots | m_{n+1}) \\
&= \partial_i^+ (m_1 | \dots | m_{j-1} | m_j m_{j+1} | m_{j+2} | \dots | m_{n+1}) \\
&= \partial_i^+ \partial_j^+ (m_1 | \dots | m_{n+1})
\end{aligned}$$

If $m_i m_{i+1} = 1$ and $i = 1$ and $j = 2$:

$$\begin{aligned}
\partial_1^+ \partial_1^+ (m_1 | \dots | m_{n+1}) &= \partial_1^+ \epsilon_1 (m_3 | \dots | m_{n+1}) \\
&= (m_3 | \dots | m_{n+1}) \\
&= \partial_1^+ (m_1 | m_2 m_3 | m_4 | \dots | m_{n+1}) \\
&= \partial_1^+ \partial_2^+ (m_1 | \dots | m_{n+1})
\end{aligned}$$

If $m_i m_{i+1} = 1$ and $i = 1$ and $m_j m_{j+1} \neq 1$ and $j > 2$:

$$\begin{aligned}
\partial_{j-1}^+ \partial_1^+ (m_1 | \dots | m_{n+1}) &= \partial_{j-1}^+ \epsilon_1 (m_3 | \dots | m_{n+1}) \\
&= \epsilon_1 \partial_{j-2}^+ (m_3 | \dots | m_{n+1}) \\
&= \epsilon_1 (m_3 | \dots | m_{j-1} | m_j m_{j+1} | m_{j+2} | \dots | m_{n+1}) \\
&= \partial_1^+ (m_1 | \dots | m_{j-1} | m_j m_{j+1} | m_{j+2} | \dots | m_{n+1}) \\
&= \partial_1^+ \partial_j^+ (m_1 | \dots | m_{n+1})
\end{aligned}$$

If $m_i m_{i+1} = 1$ and $2 \leq i \leq n-1$ and $j = i+1$:

$$\begin{aligned}
\partial_i^+ \partial_i^+ (m_1 | \dots | m_{n+1}) &= \partial_i^+ \Gamma_{i-1}^+ (m_1 | \dots | m_{i-1} | m_{i+2} | \dots | m_{n+1}) \\
&= (m_1 | \dots | m_{i-1} | m_{i+2} | \dots | m_{n+1}) \\
&= \partial_i^+ (m_1 | \dots | m_i | m_{i+1} m_{i+2} | m_{i+3} | \dots | m_{n+1}) \\
&= \partial_i^+ \partial_{i+1}^+ (m_1 | \dots | m_{n+1})
\end{aligned}$$

If $m_i m_{i+1} = 1$ and $2 \leq i \leq n-1$ and $m_j m_{j+1} \neq 1$ and $j > i+1$.

$$\begin{aligned}
\partial_{j-1}^+ \partial_i^+ (m_1 | \dots | m_{n+1}) &= \partial_{j-1}^+ \Gamma_{i-1}^+ (m_1 | \dots | m_{i-1} | m_{i+2} | \dots | m_{n+1}) \\
&= \Gamma_{i-1}^+ \partial_{j-2}^+ (m_1 | \dots | m_{i-1} | m_{i+2} | \dots | m_{n+1}) \\
&= \Gamma_{i-1}^+ (m_1 | \dots | m_{i-1} | m_{i+2} | \dots | m_{j-1} | m_j m_{j+1} | m_{j+2} | \dots | m_{n+1}) \\
&= \partial_i^+ (m_1 | \dots | m_{j-1} | m_j m_{j+1} | m_{j+2} | \dots | m_{n+1}) \\
&= \partial_i^+ \partial_j^+ (m_1 | \dots | m_{n+1})
\end{aligned}$$

If $i = 1$ and $m_j m_{j+1} = 1$ and $j = 2$

$$\begin{aligned}
\partial_1^+ \partial_1^+ (m_1 | \dots | m_{n+1}) &= \partial_1^+ (m_1 m_2 | \dots | m_{n+1}) \\
&= (m_1 | m_4 | \dots | m_{n+1}) \\
&= \partial_1^+ \epsilon_1 (m_1 | m_4 | \dots | m_{n+1}) \\
&= \partial_i^+ \partial_2^+ (m_1 | \dots | m_{n+1})
\end{aligned}$$

If $i \neq 1, n-1$ and $m_j m_{j+1} = 1$ and $j = i+1$

$$\begin{aligned}
\partial_i^+ \partial_i^+ (m_1 | \dots | m_{n+1}) &= \partial_i^+ (m_1 | \dots | m_{i-1} | m_i m_{i+1} | m_{i+2} | \dots | m_{n+1}) \\
&= (m_1 | \dots | m_i | m_{i+3} | \dots | m_{n+1}) \\
&= \partial_i^+ \Gamma_i^+ (m_1 | \dots | m_i | m_{i+3} | \dots | m_{n+1}) \\
&= \partial_i^+ \partial_{i+1}^+ (m_1 | \dots | m_{n+1})
\end{aligned}$$

If $i = n-1$ and $m_j m_{j+1} = 1$ and $j = n$.

$$\begin{aligned}
\partial_{n-1}^+ \partial_{n-1}^+ (m_1 | \dots | m_{n+1}) &= \partial_{n-1}^+ (m_1 | \dots | m_{n-2} | m_{n-1} m_n | m_{n+1}) \\
&= (m_1 | \dots | m_{n-1}) \\
&= \partial_{n-1}^+ \epsilon_{n-1} (m_1 | \dots | m_{n-1}) \\
&= \partial_{n-1}^+ \partial_n^+ (m_1 | \dots | m_{n+1})
\end{aligned}$$

If $m_i m_{i+1} \neq 1$ and $m_j m_{j+1} = 1$ and $i+2 \leq j \leq n-1$

$$\begin{aligned}
\partial_{j-1}^+ \partial_i^+ (m_1 | \dots | m_n) &= \partial_{j-1}^+ (m_1 | \dots | m_{i-1} | m_i m_{i+1} | m_{i+2} | \dots | m_{n+1}) \\
&= \Gamma_{j-2}^+ (m_1 | \dots | m_{i-1} | m_i m_{i+1} | m_{i+2} | \dots | m_{j-1} | m_{j+2} | \dots | m_{n+1}) \\
&= \Gamma_{j-2}^+ \partial_i^+ (m_1 | \dots | m_{j-1} | m_{j+2} | \dots | m_{n+1}) \\
&= \partial_i^+ \Gamma_{j-1}^+ (m_1 | \dots | m_{j-1} | m_{j+2} | \dots | m_{n+1}) \\
&= \partial_i^+ \partial_j^+ (m_1 | \dots | m_{n+1})
\end{aligned}$$

If $m_i m_{i+1} \neq 1$ and $m_j m_{j+1} = 1$ and $i+2 \leq j = n$

$$\begin{aligned}
\partial_{n-1}^+ \partial_i^+ (m_1 | \dots | m_n) &= \partial_{n-1}^+ (m_1 | \dots | m_{i-1} | m_i m_{i+1} | m_{i+2} | \dots | m_{n+1}) \\
&= \epsilon_{n-2} (m_1 | \dots | m_{i-1} | m_i m_{i+1} | m_{i+2} | \dots | m_{n-1}) \\
&= \epsilon_{n-2} \partial_i^+ (m_1 | \dots | m_{n-1}) \\
&= \partial_i^+ \epsilon_{n-1} (m_1 | \dots | m_{n-1}) \\
&= \partial_i^+ \partial_n^+ (m_1 | \dots | m_{n+1})
\end{aligned}$$

If $m_i m_{i+1} = 1$ and $m_j m_{j+1} = 1$ and $i = 1$ and $3 \leq j \leq n - 1$

$$\begin{aligned}
\partial_{j-1}^+ \partial_1^+ (m_1 | \dots | m_{n+1}) &= \partial_{j-1}^+ \epsilon_1 (m_3 | \dots | m_{n+1}) \\
&= \epsilon_1 \partial_{j-2}^+ (m_3 | \dots | m_{n+1}) \\
&= \epsilon_1 \Gamma_{j-3}^+ (m_3 | \dots | m_{j-1} | m_{j+2} | \dots | m_{n+1}) \\
&= \Gamma_{j-2}^+ \epsilon_1 (m_3 | \dots | m_{j-1} | m_{j+2} | \dots | m_{n+1}) \\
&= \Gamma_{j-2}^+ \partial_1^+ (m_1 | \dots | m_{j-1} | m_{j+2} | \dots | m_{n+1}) \\
&= \partial_1^+ \Gamma_{j-1}^+ (m_1 | \dots | m_{j-1} | m_{j+2} | \dots | m_{n+1}) \\
&= \partial_1^+ \partial_j^+ (m_1 | \dots | m_{n+1})
\end{aligned}$$

If $m_i m_{i+1} = 1$ and $m_j m_{j+1} = 1$ and $i = 1$ and $3 \leq j = n$

$$\begin{aligned}
\partial_{n-1}^+ \partial_1^+ (m_1 | \dots | m_{n+1}) &= \partial_{n-1}^+ \epsilon_1 (m_3 | \dots | m_{n+1}) \\
&= \epsilon_1 \partial_{n-2}^+ (m_3 | \dots | m_{n+1}) \\
&= \epsilon_1 \epsilon_{n-3} (m_3 | \dots | m_{n-1}) \\
&= \epsilon_{n-2} \epsilon_1 (m_3 | \dots | m_{n-1}) \\
&= \epsilon_{n-2} \partial_1^+ (m_1 | \dots | m_{n-1}) \\
&= \partial_1^+ \epsilon_{n-1} (m_1 | \dots | m_{n-1}) \\
&= \partial_1^+ \partial_n^+ (m_1 | \dots | m_n)
\end{aligned}$$

If $m_i m_{i+1} = 1$ and $m_j m_{j+1} = 1$ and $2 \leq i$ and $i + 2 \leq j \leq n - 1$:

$$\begin{aligned}
\partial_{j-1}^+ \partial_i^+ (m_1 | \dots | m_{n+1}) &= \partial_{j-1}^+ \Gamma_{i-1}^+ (m_1 | \dots | m_{i-1} | m_{i+2} | \dots | m_{n+1}) \\
&= \Gamma_{i-1}^+ \partial_{j-2}^+ (m_1 | \dots | m_{i-1} | m_{i+2} | \dots | m_{n+1}) \\
&= \Gamma_{i-1}^+ \Gamma_{j-3}^+ (m_1 | \dots | m_{i-1} | m_{i+2} | \dots | m_{j-1} | m_{j+2} | \dots | m_{n+1}) \\
&= \Gamma_{j-2}^+ \Gamma_{i-1}^+ (m_1 | \dots | m_{i-1} | m_{i+2} | \dots | m_{j-1} | m_{j+2} | \dots | m_{n+1}) \\
&= \Gamma_{j-2}^+ \partial_i^+ (m_1 | \dots | m_{j-1} | m_{j+2} | \dots | m_{n+1}) \\
&= \partial_i^+ \Gamma_{j-1}^+ (m_1 | \dots | m_{j-1} | m_{j+2} | \dots | m_{n+1}) \\
&= \partial_i^+ \partial_j^+ (m_1 | \dots | m_{n+1})
\end{aligned}$$

If $m_i m_{i+1} = 1$ and $m_j m_{j+1} = 1$ and $2 \leq i$ and $i + 2 < j = n$:

$$\begin{aligned}
\partial_{n-1}^+ \partial_i^+ (m_1 | \dots | m_{n+1}) &= \partial_{n-1}^+ \Gamma_{i-1}^+ (m_1 | \dots | m_{i-1} | m_{i+2} | \dots | m_{n+1}) \\
&= \Gamma_{i-1}^+ \partial_{n-2}^+ (m_1 | \dots | m_{i-1} | m_{i+2} | \dots | m_{n+1}) \\
&= \Gamma_{i-1}^+ \epsilon_{n-3} (m_1 | \dots | m_{i-1} | m_{i+2} | \dots | m_{n-1}) \\
&= \epsilon_{n-2} \Gamma_{i-1}^+ (m_1 | \dots | m_{i-1} | m_{i+2} | \dots | m_{n-1}) \\
&= \epsilon_{n-2} \partial_i^+ (m_1 | \dots | m_{n-1}) \\
&= \partial_i^+ \epsilon_{n-1} (m_1 | \dots | m_{n-1}) \\
&= \partial_i^+ \partial_n^+ (m_1 | \dots | m_{n+1})
\end{aligned}$$

If $m_i m_{i+1} = 1$ and $m_j m_{j+1} = 1$ and $i + 2 = j = n$:

$$\begin{aligned}
\partial_{n-1}^+ \partial_{n-2}^+ (m_1 | \dots | m_{n+1}) &= \partial_{n-1}^+ \Gamma_{n-3}^+ (m_1 | \dots | m_{n-3} | m_n | m_{n+1}) \\
&= \Gamma_{n-3}^+ \partial_{n-2}^+ (m_1 | \dots | m_{n-3} | m_n | m_{n+1}) \\
&= \Gamma_{n-3}^+ \epsilon_{n-3} (m_1 | \dots | m_{n-3}) \\
&= \epsilon_{n-2} \epsilon_{n-3} (m_1 | \dots | m_{n-3}) \\
&= \epsilon_{n-2} \partial_{n-2}^+ (m_1 | \dots | m_{n-1}) \\
&= \partial_{n-2}^+ \epsilon_{n-1} (m_1 | \dots | m_{n-1}) \\
&= \partial_{n-2}^+ \partial_n^+ (m_1 | \dots | m_{n+1})
\end{aligned}$$

□

Lemma 5.3.2.2. *The Gray-polygraph $\mathbf{RStd}(M)$ is a terminating targets-only Gray-polygraph. The monoid presented by $\mathbf{RStd}(M)$ is M .*

For any $(m_1 | \dots | m_{n+1}) \in \mathbf{RStd}(M)_n$, $\mathbf{br}(m_1 | \dots | m_{n+1})$ is the n -branching given by, for $1 \leq k \leq n$:

$$\mathbf{br}(m_1 | \dots | m_{n+1})_k = m_1 \otimes \dots \otimes m_{n-k-1} \otimes (m_{n-k+1} | m_{n-k+2}) \otimes m_{n-k+2} \otimes \dots \otimes m_{n+1}$$

Moreover, those form a good choice of critical branchings.

Proof. Let $m_1, m_2 \in M$, with $m_1, m_2 \neq 1$. Then $l(\partial_1^-(m_1 | m_2)) = 2 > 1 \geq l(\partial_1^+(m_1 | m_2))$. So $\mathbf{RStd}(M)$ is terminating. Moreover, the formula $\partial_i^-(m_1 | \dots | m_{n+1}) = (m_1 | \dots | m_i) \otimes (m_{i+1} | \dots | m_{n+1})$ shows that it is targets-only.

Finally, recall that the standard presentation of M is the following:

$$\langle (m) \in M | (m_1) \otimes (m_2) = (m_1 m_2), (1) = 1 \rangle$$

In particular, using the relation $(1) = 1$ we can remove (1) from the generators. Moreover, in this case the relations $(m_1) \otimes (m_2) = (m_1 m_2)$ become redundant whenever $m_1 = 1$ or $m_2 = 1$. In the end, we get $\mathbf{RStd}(M)_0$ as set of generators, and $\mathbf{RStd}(M)_1$ as generating relations. So the monoid presented by $\mathbf{RStd}(M)$ is indeed M .

We prove the formula for $\mathbf{br}(m_1 | \dots | m_{n+1})$ by induction on n . For $n = 1$ this just means that $\mathbf{br}(m_1 | m_2) = (m_1 | m_2)$. For general $n > 1$, we have:

$$\mathbf{br}(m_1 | \dots | m_{n+1}) = (\mathbf{br}(\partial_1^-(m_1 | \dots | m_{n+1})), \mathbf{br}(\partial_n^-(m_1 | \dots | m_{n+1}))_{n-1})$$

So for $1 \leq k < n$ we get $\mathbf{br}(m_1 | \dots | m_{n+1})_k = \mathbf{br}(\partial_1^-(m_1 | \dots | m_{n+1}))_k = m_1 \otimes \mathbf{br}(m_2 | \dots | m_{n+1})_k$. By induction, we finally get the required formula:

$$\mathbf{br}(m_1 | \dots | m_{n+1})_k = m_1 \otimes m_2 \otimes \dots \otimes m_{n-k-1} \otimes (m_{n-k+1} | m_{n-k+2}) \otimes m_{n-k+2} \otimes \dots \otimes m_{n+1}$$

And for $k = n$ we have $\mathbf{br}(m_1 | \dots | m_{n+1})_n = \mathbf{br}(\partial_n^-(m_1 | \dots | m_{n+1}))_{n-1} = (m_1 | m_2) \otimes m_3 \otimes \dots \otimes m_{n+1}$, as required.

Finally, up to permutations, all the critical branchings are of this form, making the family $\mathbf{br}(m_1 | \dots | m_{n+1})$ a choice of critical branchings. It is a good choice thanks to the equation $\partial_i \mathbf{br}(m_1 | \dots | m_{n+1}) = \mathbf{br}(m_1 | \dots | m_i) \otimes \mathbf{br}(m_{i+1} | \dots | m_{n+1})$. □

Theorem 5.3.2.3. *The Gray monoid $\mathbf{RStd}(M)$ forms a polygraphic resolution of M .*

Proof. The only hypothesis missing to apply Theorem 5.1.3.8 is the description of a morphism of simplicial monoid

$$\Phi : \mathbf{LocBr}(\mathbf{RStd}(M)) \rightarrow V(\mathbf{RStd}(M)^{G(1)}).$$

By Proposition 5.3.1.14 together with Lemma 5.3.2.2, $\mathbf{LocBr}(\mathbf{RStd}(M))$ is freely generated by the branchings $\mathbf{br}(m_1 | \dots | m_{n+1})$, so it is enough to define Φ on those. We define $\Phi(\mathbf{br}(m_1 | \dots | m_{n+1})) := (m_1 | \dots | m_{n+1})$, so that Φ also satisfies the required equation. Theorem 5.1.3.8 therefore allows us to conclude. \square

5.3.3 Squier's resolution of a monoid

In this section, we suppose given a convergent Gray 1-polygraph Σ presenting a monoid M . We show how it is possible to extend this data in a polygraphic resolution of M satisfying the hypothesis of Theorem 5.1.3.8. We suppose chosen a good choice of critical branchings in $\mathbf{Br}(\Sigma)$, which is possible by Lemma 5.3.1.17.

Definition 5.3.3.1. Let \mathbf{C} be a cubical ω -category, a *half- n -shell* in \mathbf{C} is the data of $\bar{A} = (A_1, \dots, A_n) \in \mathbf{C}_{n-1}$ such that for all $j > i$, $\partial_{j-1}^- A_i = \partial_i^- A_j$.

We denote A_i by $\partial_i^- \bar{A}$. For any half- n -shell \bar{A} in \mathbf{C} , and $1 \leq i \leq n$, we define a half $(n-1)$ -shell $\partial_i^+ \bar{A}$ by putting:

$$(\partial_i^+ \bar{A})_j = \begin{cases} \partial_j^+ A_{i-1} & 1 \leq j < i \\ \partial_j^+ A_{i+1} & i \leq j \leq n-1 \end{cases}$$

By definition, we have for any half n -shell \bar{A} and $1 \leq i \neq j \leq n$: $\partial_j^\alpha \partial_i^\beta \bar{A} = \partial_{ij}^\beta \partial_i^\alpha \bar{A}$.

Proposition 5.3.3.2. *Let Σ be a terminating Gray $(\omega, 1)$ -polygraph. Suppose that there exists a natural transformation $S : \iota_n \Rightarrow \mathbf{NF} \circ \pi$.*

Let $1 \leq p \leq n$, and let \bar{A} be a half p -shell in $[\Sigma]^(1)$. Define the following $\{0, 1\}^p$ grid in $[\Sigma]^*(1)$:*

$$C_s[\bar{A}] = \begin{cases} \Gamma_1^{+, s^-(0)} S(\partial_{s^-(0)}^- \bar{A}) & s \neq (1, \dots, 1) \\ \epsilon_1^p \mathbf{NF}(\pi \bar{A}) & s = (1, \dots, 1) \end{cases}$$

Then $C_\bullet[\bar{A}]$ is a composable grid. Moreover, we have for all $1 \leq i \leq p$:

$$\partial_i^\alpha \mathbf{Comp}(C_\bullet[\bar{A}]) = \begin{cases} \partial_i^- \bar{A} & \alpha = - \\ C_\bullet[\partial_i^+ \bar{A}] & \alpha = + \end{cases}$$

Proof. First, we show $C_\bullet[\bar{A}]$ is a composable grid:

Let $s \in \{0, 1\}^p$ and suppose that $s(i) = 0$ for some $1 \leq i \leq p$. We distinguish two cases. If $s(j) = 1$ for every $j \neq i$ then $\Gamma_1^{+, s^-(0)} = [i \mapsto 1]$ and:

$$\partial_i^+ C_s[\bar{A}] = \partial_i^+ \Gamma_1^{+, s^-(0)} S(\partial_{s^-(0)}^- \bar{A}) = \partial_1^+ S(\partial_i^- \bar{A}) = \mathbf{NF}(\pi(A_i)) = \epsilon_1^{p-1} \hat{u}$$

Since necessarily $\mathbf{S}_i s = (1, \dots, 1)$, we have on the other hand $\partial_i^+ C_s = \partial_i^- C_{\mathbf{S}_i s}$. Suppose now that there exists $j \neq i$ such that $s(j) = 0$. Then:

$$\begin{aligned} \partial_i^+ C_\bullet[\bar{A}] &= \partial_i^+ \Gamma_1^{+, s^-(0)} S(\partial_{s^-(0)}^- \bar{A}) \\ &= \Gamma_1^{+, (s^-(0) \setminus \{i\})_i} S(\partial_{s^-(0)}^- \bar{A}) = \Gamma_1^{+, (\mathbf{S}_i s)^-(0)_i} S(\partial_{s^-(0)}^- \bar{A}) \end{aligned}$$

$$\begin{aligned}
\partial_i^- C_\bullet[\bar{A}] &= \partial_i^- \Gamma_1^{+, (\mathbf{S}_i s)^-(0)} S(\partial_{(\mathbf{S}_i s)^-(0)}^- \bar{A}) \\
&= \Gamma_1^{+, (\mathbf{S}_i s)^-(0)i} \partial_{i_{(\mathbf{S}_i s)^-(0)}+1}^- S(\partial_{(\mathbf{S}_i s)^-(0)}^- \bar{A}) \\
&= \Gamma_1^{+, (\mathbf{S}_i s)^-(0)i} S(\partial_{i_{(\mathbf{S}_i s)^-(0)}^-}^- \partial_{(\mathbf{S}_i s)^-(0)}^- \bar{A}) \\
&= \Gamma_1^{+, (\mathbf{S}_i s)^-(0)i} S(\partial_{s^-(0)}^- \bar{A})
\end{aligned}$$

So finally C_\bullet is composable. Let D_\bullet be the composable $\{0, 1\}^{p-1}$ grid defined by $D_t = \partial_i^- C_{t_{-i}}$ (recall that t_{-i} consists in inserting 0 in the i -th position of t). Then we have $\partial_i^- \mathbf{Comp}(C_\bullet) = \mathbf{Comp}(D_\bullet)$, and we have:

$$D_t = \partial_i^- C_{t_{-i}} = \partial_i^- \Gamma_1^{+, t_{-i}^-(0)} S(\partial_{t_{-i}^-(0)}^- \bar{A})$$

We distinguish two cases. If $t^-(0) = \emptyset$ then $\Gamma_1^{+, t_{-i}^-(0)} = [i \mapsto 1]$ and so $D_t = \partial_1^- S(\partial_i^- \bar{A}) = \partial_i^- A_i$. Otherwise, then t can be written as $\mathbf{P}_j s$ for some $j \neq i$, and then $D_{\mathbf{P}_j s} \in \mathbf{Im}(\epsilon_j)$. In a manner symmetric to that of simple grids, we therefore have that $\mathbf{Comp}(D_\bullet) = A_i$, which proves that $\mathbf{Comp}(C_\bullet)$ satisfies the first condition.

For the second condition, let D_\bullet be the composable $\{0, 1\}^{p-1}$ grid defined by $D_t = \partial_i^+ C_{t_{+i}}$ (recall that t_{+i} consists in inserting 1 in the i -th position of t). Then we have $\partial_i^+ \mathbf{Comp}(C_\bullet) = \mathbf{Comp}(D_\bullet)$, and we have, if $t \neq (1, \dots, 1)$:

$$\begin{aligned}
D_t &= \partial_i^+ C_{t_{+i}} = \partial_i^+ \Gamma_1^{+, t_{+i}^-(0)} S(\partial_{t_{+i}^-(0)}^- \bar{A}) \\
&= \partial_i^+ \Gamma_1^{+, (t^-(0))^i} S(\partial_{(t^-(0))^i}^- \bar{A}) \\
&= \Gamma_1^{+, t^-(0)} \partial_{i_{t^-(0)}+1}^+ S(\partial_{(t^-(0))^i}^- \bar{A}) \\
&= \Gamma_1^{+, t^-(0)} S(\partial_{i_{t^-(0)}^+}^+ \partial_{(t^-(0))^i}^- \bar{A}) \\
&= \Gamma_1^{+, t^-(0)} S(\partial_{(t^-(0))}^- \partial_i^+ \bar{A}) = C_t[\partial_i^+ \bar{A}]
\end{aligned}$$

And similarly if $t = (1, \dots, 1)$ then $D_t = \epsilon_1^{p-1} u = C_t[\partial_i^+ \bar{A}]$. So finally $\partial_i^+ \mathbf{Comp}(C_\bullet) = \mathbf{Comp}(D_\bullet) = \mathbf{Comp}(C_\bullet[\partial_i^+ \bar{A}])$.

□

The previous Proposition expressed how the existence of S assured that any half- p -shell has a filling, for $p \leq n$. The next Lemma asserts on the other hand that half- $(n+1)$ -shells can be completed into an $(n+1)$ -shell.

Lemma 5.3.3.3. *Let Σ be a terminating Gray $(\omega, 1)$ -polygraph. Suppose that there exists a natural transformation $S : \iota_n \Rightarrow \mathbf{NF} \circ \pi$.*

Let \bar{A} be a half $(n+1)$ -shell in $[\Sigma]^(1)$. There exists an $(n+1)$ -shell \bar{B} in $[\Sigma]^*(1)$ such that $\partial_i^- \bar{B} = \partial_i^- \bar{A}$ for all $1 \leq i \leq n+1$.*

Proof. Using Proposition 5.3.3.2, let $B_i^+ = \mathbf{Comp}(C_\bullet[\partial_i^+ A])$. Then we have, for $j > i$:

$$\begin{aligned}
\partial_{j-1}^- \partial_i^- \bar{B} &= \partial_{j-1}^- \partial_i^- \bar{A} = \partial_i^- \partial_j^- \bar{B} \\
\partial_{j-1}^- \partial_i^+ \bar{B} &= \partial_{j-1}^- \mathbf{Comp}(C_\bullet[\partial_i^+ \bar{A}]) = \partial_{j-1}^- \partial_i^+ \bar{A} \\
&= \partial_i^+ \partial_j^- \bar{A} = \partial_i^+ \partial_j^- \bar{B} \\
\partial_{j-1}^+ \partial_i^- \bar{B} &= \partial_{j-1}^+ \partial_i^- \bar{A} = \partial_{j-1}^+ \partial_i^- \mathbf{Comp}(C_\bullet[\bar{A}]) \\
&= \partial_i^- \partial_j^+ \mathbf{Comp}(C_\bullet[\bar{A}]) = \partial_i^- \mathbf{Comp}(C_\bullet[\partial_j^+ \bar{A}]) = \partial_i^- \partial_j^+ \bar{B} \\
\partial_{j-1}^+ \partial_i^+ \bar{B} &= \partial_{j-1}^+ \mathbf{Comp}(C_\bullet[\partial_i^+ \bar{A}]) = \mathbf{Comp}(C_\bullet[\partial_{j-1}^+ \partial_i^+ \bar{A}]) \\
&= \mathbf{Comp}(C_\bullet[\partial_i^+ \partial_j^+ \bar{A}]) = \partial_i^+ \partial_j^+ \bar{B}
\end{aligned}$$

□

Proposition 5.3.3.4. *Let Σ be a targets-only terminating Gray $(n, 1)$ -polygraph, and let $M = \Sigma_0^{G(0)}/\Sigma_1^{G(0)}$ be the monoid presented by Σ . Suppose that there exists a natural transformation $S : \iota_n \Rightarrow \mathbf{NF} \circ \pi$ and a morphism of augmented symmetric simplicial sets $\Phi : \mathbf{BrLoc}(\Sigma)_{\leq n} \rightarrow V(\Sigma^{G(1)})$ such that for all $A \in [\Sigma]_{\leq n}$, $\Phi(\mathbf{br}(A)) = A$.*

Then it is possible to extend Σ into a targets-only $(n+1, 1)$ -polygraph such that there exists a morphism of augmented symmetric simplicial sets $\Phi : \mathbf{BrLoc}(\Sigma)_{\leq n+1} \rightarrow V(\Sigma^{G(1)})$ satisfying for all $A \in [\Sigma]_{\leq n}$, $\Phi(\mathbf{br}(A)) = A$.

Proof. Let \bar{f} be a distinguished $(n+1)$ -critical branching in $\mathbf{BrLoc}(\Sigma)$. Let $A_i = \Phi(\partial_i \bar{f})$. Since Φ is a morphism of semi-simplicial sets, this defines a half- $(n+1)$ -shell in $\Sigma^{G(1)}$. By Lemma 5.3.3.3, let us complete this in a shell $\bar{B}^{\bar{f}}$. We now define Σ_{n+1} to be a set of cells $B^{\bar{f}}$, with shell given by $\bar{B}^{\bar{f}}$. Then since $\mathbf{BrLoc}(\Sigma)$ is freely generated by critical branchings, it is enough to define Φ on the distinguished $(n+1)$ -critical branching, which is done in the obvious way : $\Phi(\bar{f}) = B^{\bar{f}}$. By construction, this verifies all the required properties. □

Theorem 5.3.3.5. *Let Σ be a convergent Gray 1-polygraph and let M be the monoid presented by Σ . There exists a completion of Σ into a Gray $(\omega, 1)$ -polygraph Σ such that:*

- *The n -cells of Σ_n correspond to the n -critical branchings*
- *Σ is a resolution of M (more specifically, Σ satisfies the hypothesis of Theorem 5.1.3.8).*

Proof. This is just a repeated application of Proposition 5.2.3.4 to extend Σ , followed by an application of Proposition 5.3.3.4 to extend S . □

Bibliography

- [1] Wilhelm Ackermann and David Hilbert. Grundzüge der theoretischen logik. *Berlin, Springer*, 1037:23, 1928. [4](#)
- [2] Fahd Ali Al-Agl, Ronald Brown, and Richard Steiner. Multiple categories: the equivalence of a globular and a cubical approach. *Adv. Math.*, 170(1):71–118, 2002. [17](#), [18](#), [21](#), [22](#), [104](#), [105](#), [108](#), [109](#), [110](#), [118](#), [121](#), [124](#), [134](#), [146](#)
- [3] Fahd Ali Al-Agl and Richard Steiner. Nerves of multiple categories. *Proc. London Math. Soc. (3)*, 66(1):92–128, 1993. [17](#)
- [4] Franz Baader and Tobias Nipkow. *Term rewriting and all that*. Cambridge university press, 1999. [6](#), [95](#)
- [5] John C Baez and James Dolan. Categorification. *arXiv preprint math/9802029*, 1998. [9](#)
- [6] MA Batanin. Computads for finitary monads on globular sets. *Contemporary Mathematics*, 230:37–58, 1998. [145](#)
- [7] Jean Bénabou. Introduction to bicategories. In *Reports of the Midwest Category Seminar*, pages 1–77. Springer, 1967. [36](#)
- [8] Clemens Berger and Ieke Moerdijk. Resolution of coloured operads and rectification of homotopy algebras. *Contemporary Mathematics*, 431:31–58, 2007. [23](#)
- [9] Marc Bezem, Thierry Coquand, and Simon Huber. A model of type theory in cubical sets. In *19th International Conference on Types for Proofs and Programs (TYPES 2013)*, volume 26, pages 107–128, 2014. [17](#)
- [10] Ronald V Book and Friedrich Otto. String-rewriting systems. In *String-Rewriting Systems*, pages 35–64. Springer, 1993. [6](#)
- [11] Aldridge K. Bousfield and Daniel M. Kan. *Homotopy limits, completions and localizations*. Lecture Notes in Math., Vol. 304. Springer-Verlag, Berlin-New York, 1972. [17](#)
- [12] Ronald Brown and Philip J. Higgins. Sur les complexes croisés, ω -groupoïdes, et T -complexes. *C. R. Acad. Sci. Paris Sér. A-B*, 285(16):A997–A999, 1977. [17](#)
- [13] Ronald Brown and Philip J. Higgins. The equivalence of ∞ -groupoids and crossed complexes. *Cahiers Topologie Géom. Différentielle*, 22(4):371–386, 1981. [28](#)
- [14] Ronald Brown and Philip J. Higgins. On the algebra of cubes. *J. Pure Appl. Algebra*, 21(3):233–260, 1981. [17](#)
- [15] Ronald Brown and Philip J. Higgins. Cubical abelian groups with connections are equivalent to chain complexes. *Homology Homotopy Appl.*, 5(1):49–52, 2003. [17](#)

- [16] Ronald Brown, Philip J. Higgins, and Rafael Sivera. *Nonabelian algebraic topology*, volume 15 of *EMS Tracts in Mathematics*. European Mathematical Society (EMS), Zürich, 2011. Filtered spaces, crossed complexes, cubical homotopy groupoids, With contributions by Christopher D. Wensley and Sergei V. Soloviev. 17
- [17] Ronald Brown and Christopher B. Spencer. Double groupoids and crossed modules. *Cahiers Topologie Géom. Différentielle*, 17(4):343–362, 1976. 17
- [18] Albert Burroni. Higher-dimensional word problems with applications to equational logic. *Theoretical computer science*, 115(1):43–62, 1993. 7, 28, 31
- [19] Alonzo Church. A set of postulates for the foundation of logic. *Annals of mathematics*, pages 346–366, 1932. 4, 5
- [20] Alonzo Church. An unsolvable problem of elementary number theory. *American journal of mathematics*, 58(2):345–363, 1936. 4
- [21] Denis-Charles Cisinski. *Les préfaisceaux comme modèles des types d’homotopie*. Société mathématique de France, 2006. 17
- [22] Louis Crane. Clock and category: Is quantum gravity algebraic? *Journal of Mathematical Physics*, 36(11):6180–6193, 1995. 9
- [23] Louis Crane and Igor B Frenkel. Four-dimensional topological quantum field theory, hopf categories, and the canonical bases. *Journal of Mathematical Physics*, 35(10):5136–5154, 1994. 9
- [24] Sjoerd E. Crans. Pasting schemes for the monoidal biclosed structure on ω -cat. 1995. 17
- [25] Sjoerd E. Crans. Localizations of transfors. *K-Theory*, 28(1):39–105, 2003. 21, 133
- [26] Patrick Dehornoy. The subword reversing method. *International Journal of Algebra and Computation*, 21(1-2):71–118, 2011. 90
- [27] Anthony D Elmendorf, Igor Kriz, Michael A Mandell, and J Peter May. *Rings, modules, and algebras in stable homotopy theory*. Number 47. American Mathematical Soc., 2007. 140, 141
- [28] Richard Garner. Homomorphisms of higher categories. *Advances in Mathematics*, 224(6):2269–2311, 2010. 23, 140, 145
- [29] Philippe Gaucher. Homotopy invariants of higher dimensional categories and concurrency in computer science. *Math. Structures Comput. Sci.*, 10(4):481–524, 2000. Geometry and concurrency. 17
- [30] Philippe Gaucher. Combinatorics of branchings in higher dimensional automata. *Theory Appl. Categ.*, 8:No. 12, 324–376, 2001. 17
- [31] Stéphane Gaussent, Yves Guiraud, and Philippe Malbos. Coherent presentations of artin monoids. *Compositio Mathematica*, 151(05):957–998, 2015. 65, 70
- [32] Kurt Gödel. Über formal unentscheidbare sätze der principia mathematica und verwandter systeme i. *Monatshefte für mathematik und physik*, 38(1):173–198, 1931. 4

- [33] Eric Goubault. Some geometric perspectives in concurrency theory. *Homology Homotopy Appl.*, 5(2):95–136, 2003. Algebraic topological methods in computer science (Stanford, CA, 2001). [17](#)
- [34] Marco Grandis. Higher cospans and weak cubical categories (cospans in algebraic topology. I). *Theory Appl. Categ.*, 18:No. 12, 321–347, 2007. [17](#), [21](#), [130](#)
- [35] Marco Grandis. *Directed algebraic topology*, volume 13 of *New Mathematical Monographs*. Cambridge University Press, Cambridge, 2009. Models of non-reversible worlds. [18](#)
- [36] Marco Grandis and Luca Mauri. Cubical sets and their site. *Theory Appl. Categ.*, 11:No. 8, 185–211, 2003. [105](#), [106](#)
- [37] Yves Guiraud, Eric Hoffbeck, and Philippe Malbos. Linear polygraphs and koszulity of algebras. *arXiv preprint arXiv:1406.0815*, 2014. [8](#), [23](#)
- [38] Yves Guiraud and Philippe Malbos. Higher-dimensional categories with finite derivation type. *Theory and Applications of Categories*, 22(18):420–478, 2009. [8](#), [12](#), [13](#), [18](#), [28](#), [33](#), [34](#), [35](#)
- [39] Yves Guiraud and Philippe Malbos. Coherence in monoidal track categories. *Mathematical Structures in Computer Science*, 22(06):931–969, 2012. [8](#), [28](#), [40](#)
- [40] Yves Guiraud and Philippe Malbos. Higher-dimensional normalisation strategies for acyclicity. *Advances in Mathematics*, 231(3):2294–2351, 2012. [10](#), [16](#), [18](#), [23](#), [24](#), [26](#), [31](#), [54](#), [140](#)
- [41] Yves Guiraud and Philippe Malbos. Polygraphs of finite derivation type. *Mathematical Structures in Computer Science*, pages 1–47, 2016. [28](#)
- [42] Amar Hadzihasanovic. The algebra of entanglement and the geometry of composition. *arXiv preprint arXiv:1709.08086*, 2017. [149](#)
- [43] Philip J. Higgins. Thin elements and commutative shells in cubical ω -categories. *Theory Appl. Categ.*, 14:No. 4, 60–74, 2005. [107](#), [108](#), [113](#)
- [44] Mark Hovey. Monoidal model categories. *arXiv preprint math/9803002*, 1998. [23](#)
- [45] Mark Hovey. *Model categories*. Number 63. American Mathematical Soc., 2007. [148](#)
- [46] Matthias Jantzen. *Semi Thue systems and generalized Church-Rosser properties*. Institut für Informatik, Universität Hamburg, 1982. [6](#)
- [47] Matthias Jantzen. A note on a special one-rule semi-thue system. *Information Processing Letters*, 21(3):135–140, 1985. [6](#)
- [48] Daniel M. Kan. Abstract homotopy. I. *Proc. Nat. Acad. Sci. U.S.A.*, 41:1092–1096, 1955. [17](#)
- [49] Daniel M. Kan. Functors involving c.s.s. complexes. *Trans. Amer. Math. Soc.*, 87:330–346, 1958. [17](#)
- [50] Deepak Kapur and Paliath Narendran. A finite thue system with decidable word problem and without equivalent finite canonical system. *Theoretical Computer Science*, 35:337–344, 1985. [6](#)

- [51] Gregory Maxwell. Kelly. Coherence theorems for lax algebras and for distributive laws. In *Category seminar*, pages 281–375. Springer, 1974. 8
- [52] Gregory Maxwell. Kelly and Saunders MacLane. Closed coherence for a natural transformation. In *Coherence in categories*, pages 1–28. Lecture Notes in Math., Vol. 281. Springer, Berlin, 1972. 8
- [53] Donald E Knuth and Peter B Bendix. Simple word problems in universal algebras. In *Automation of Reasoning*, pages 342–376. Springer, 1983. 6
- [54] Stephen Lack. A quillen model structure for 2-categories. *K-theory*, 26(2):171–205, 2002. 23, 149
- [55] Yves Lafont, François Métayer, and Krzysztof Worytkiewicz. A folk model structure on omega-cat. *Advances in Mathematics*, 224(3):1183–1231, 2010. 10, 147
- [56] Jean-Louis Loday and Bruno Vallette. *Algebraic operads*, volume 346. Springer Science & Business Media, 2012. 9
- [57] Maxime Lucas. A cubical Squier’s theorem. Preprint, <http://arxiv.org/abs/1612.06541v1>. 18
- [58] Roger C Lyndon and Paul E Schupp. *Combinatorial group theory*. Springer, 2015. 70
- [59] Saunders Mac Lane. Natural associativity and commutativity. *Rice University Studies*, 49(4):28–46, 1963. 8
- [60] Saunders Mac Lane. *Categories for the working mathematician*, volume 5. Springer Science & Business Media, 2013. 140
- [61] Saunders Mac Lane and Robert Paré. Coherence for bicategories and indexed categories. *Journal of Pure and Applied Algebra*, 37(1):59–80, 1985. 8, 39
- [62] Georges Maltsiniotis et al. La catégorie cubique avec connexions est une catégorie test stricte. *Homology, Homotopy Appl.*, 11(2):309–326, 2009. 17
- [63] A. Markoff. On the impossibility of certain algorithms in the theory of associative systems. *C. R. (Doklady) Acad. Sci. URSS (N.S.)*, 55:583–586, 1947. 4
- [64] Hideya Matsumoto. Générateurs et relations des groupes de weyl généralisés. *C. R. Acad. Sci.*, 258(13):3419, 1964. 17, 133
- [65] François Métayer. Resolutions by polygraphs. *Theory and Applications of Categories*, 11(7):148–184, 2003. 28
- [66] François Métayer. Cofibrant objects among higher-dimensional categories. *Homology, Homotopy and Applications*, 10(1):181–203, 2008. 31
- [67] Maxwell Herman Alexander Newman. On theories with a combinatorial definition of "equivalence". *Annals of mathematics*, pages 223–243, 1942. 5, 6
- [68] Emil L Post. Recursively enumerable sets of positive integers and their decision problems. *bulletin of the American Mathematical Society*, 50(5):284–316, 1944. 4
- [69] Emil L Post. Recursive unsolvability of a problem of thue. *The Journal of Symbolic Logic*, 12(1):1–11, 1947. 4

- [70] Anthony Power. A general coherence result. *Journal of Pure and Applied Algebra*, 57(2):165–173, 1989. [8](#)
- [71] Daniel Quillen. Rational homotopy theory. *Ann. of Math. (2)*, 90:205–295, 1969. [17](#)
- [72] Stefan Schwede and Brooke E Shipley. Algebras and modules in monoidal model categories. *Proceedings of the London Mathematical Society*, 80(2):491–511, 2000. [23](#)
- [73] Jean-Pierre Serre. Homologie singulière des espaces fibrés. Applications. *C. R. Acad. Sci. Paris*, 232:31–33, 1951. [17](#)
- [74] Craig C Squier. Word problems and a homological finiteness condition for monoids. *Journal of Pure and Applied Algebra*, 49(1-2):201–217, 1987. [6](#)
- [75] Craig C. Squier, Friedrich Otto, and Yuji Kobayashi. A finiteness condition for rewriting systems. *Theoretical Computer Science*, 131(2):271–294, 1994. [6](#), [35](#)
- [76] Richard Steiner. The algebra of directed complexes. *Appl. Categ. Structures*, 1(3):247–284, 1993. [104](#)
- [77] Richard Steiner. Omega-categories and chain complexes. *Homology Homotopy Appl.*, 6(1):175–200, 2004. [17](#), [18](#), [104](#), [120](#), [121](#), [122](#), [125](#)
- [78] Ross Street. Limits indexed by category-valued 2-functors. *Journal of Pure and Applied Algebra*, 8(2):149–181, 1976. [7](#), [28](#)
- [79] Ross Street. The algebra of oriented simplexes. *Journal of Pure and Applied Algebra*, 49(3):283–335, 1987. [7](#)
- [80] Ross Street. Categorical structures. *Handbook of algebra*, 1:529–577, 1996. [14](#), [65](#)
- [81] Ross Street. An australian conspectus of higher categories. In *Towards Higher Categories*, pages 237–264. Springer, 2010. [28](#)
- [82] Axel Thue. *Probleme über Veränderungen von Zeichenreihen nach gegebenen Regeln, von Axel Thue...* J. Dybwad, 1914. [4](#)
- [83] A. P. Tonks. Cubical groups which are Kan. *J. Pure Appl. Algebra*, 81(1):83–87, 1992. [17](#)
- [84] Alan Mathison Turing. On computable numbers, with an application to the entscheidungsproblem. *Proceedings of the London mathematical society*, 2(1):230–265, 1937. [4](#)
- [85] Alan Mathison Turing. On computable numbers, with an application to the entscheidungsproblem. a correction. *Proceedings of the London Mathematical Society*, 2(1):544–546, 1938. [4](#)
- [86] Bruno Vallette. Algebra+ homotopy= operad. *arXiv preprint arXiv:1202.3245*, 2012. [9](#)
- [87] Mark Weber. Free products of higher operad algebras. *arXiv preprint arXiv:0909.4722*, 2009. [14](#)