



HAL
open science

Asymptotic and numerical methods for fluid-structure interaction problems and applications to the materials science and engineering

Irina Malakhova-Ziablova

► **To cite this version:**

Irina Malakhova-Ziablova. Asymptotic and numerical methods for fluid-structure interaction problems and applications to the materials science and engineering. Mathematical Physics [math-ph]. Université Jean Monnet - Saint-Etienne, 2015. English. NNT : 2015STET4003 . tel-01295759v2

HAL Id: tel-01295759

<https://hal.science/tel-01295759v2>

Submitted on 12 Jan 2017

HAL is a multi-disciplinary open access archive for the deposit and dissemination of scientific research documents, whether they are published or not. The documents may come from teaching and research institutions in France or abroad, or from public or private research centers.

L'archive ouverte pluridisciplinaire **HAL**, est destinée au dépôt et à la diffusion de documents scientifiques de niveau recherche, publiés ou non, émanant des établissements d'enseignement et de recherche français ou étrangers, des laboratoires publics ou privés.



THÈSE DE DOCTORAT
PRÉSENTÉE À
L'UNIVERSITÉ JEAN MONNET DE SAINT-ÉTIENNE

ÉCOLE DOCTORALE : Sciences, Ingénierie, Santé (ED SIS 488)

Par **Irina MALAKHOVA-ZIABLOVA**

POUR OBTENIR LE GRADE DE

DOCTEUR

SPECIALITÉ : Mathématiques Appliquées

**Méthodes asymptotiques et numériques
pour les problèmes d'interaction fluide-solide et applications
en science des matériaux et en science pour ingénieur**

Directeur de la thèse : Grigory PANASENKO

Co-directeur de la thèse : Andrey GUSAROV

Soutenue le : 12 Février 2015

Devant la commission d'examen formée de :

R. STAVRE	Directrice de recherche de Institute of Mathematics of the Romanian Academy, Roumanie	Rapporteuse
J. ORLIK	Directrice de recherche de Fraunhofer Institute for Industrial Mathematics ITWM, Allemagne	Rapporteuse
V. CHIADO PIAT	Professeur de École polytechnique de Turin, Italie	Rapporteuse
R. TOUZANI	Professeur de l'Université Blaise Pascal, France	Président du jury
G.P. PANASENKO	Professeur de l'Université Jean Monnet, France	Directeur de Thèse
A.V. GUSAROV	Professeur de l'ENISE, France	Co-directeur de Thèse



A THESIS

PRESENTED AT

JEAN MONNET UNIVERSITY OF SAINT-ETIENNE

DOCTORAL SCHOOL : Sciences, Engineering, Health (ED SIS 488)

By **Irina MALAKHOVA-ZIABLOVA**

TO OBTAIN THE DEGREE OF

DOCTOR OF PHILOSOPHY

SPECIALITY : Applied Mathematics

Asymptotic and numerical methods for fluid-structure interaction problems and applications to the materials science and engineering

Scientific advisor : Grigory PANASENKO

Scientific co-advisor : Andrey GUSAROV

Defended on : 12 February 2015

In front of the examination committee consisting of :

R. STAVRE	Research Director of Institute of Mathematics of the Romanian Academy, Roumanie	Reviewer
J. ORLIK	Research Director of Fraunhofer Institute for Industrial Mathematics ITWM, Germany	Reviewer
V. CHIADO PIAT	Professor of Polytechnic University of Turin, Italy	Reviewer
R. TOUZANI	Professor of Blaise Pascal University, France	Chairman
G.P. PANASENKO	Professor of Jean Monnet University, France	Thesis advisor
A.V. GUSAROV	Professor of ENISE, France	Thesis co-advisor



This thesis is dedicated to the memory

*of my research supervisor **Arlen Mikhailovich Il'in (1932-2013)***

in the master's study in Russia, Chelyabinsk.

“Live as if you were to die tomorrow. Learn as if you were to live forever.”

(Mahatma Gandhi)

Résumé

Le but de cette thèse pluridisciplinaire est d'étudier le problème de l'interaction fluide-structure à partir du point de vue mathématique et physique. Des problèmes d'interaction d'un fluide visqueux avec une structure élastique décrivent, par exemple, des interactions entre le manteau terrestre et de la croûte terrestre, le sang et la paroi vasculaire dans un vaisseau sanguin, etc. En génie l'interaction fluide visqueux-structure apparaît lors de la formation de solution colloïdale quand un laser passe à travers le fluide influençant le substrat (ablation laser dans un liquide). Fusion sélective au laser (FSL) est utilisée pour étudier le comportement des contraintes résiduelles en dépendance des propriétés thermoélastiques et mécaniques du matériau et des formes variées des cordons rechargés. A partir du point de vue mathématique le système couplé "flux fluide visqueux – plaque mince élastique" en 3D lorsque l'épaisseur de la plaque, ε , tend vers zéro, tandis que la densité et le module de Young du matériau élastique sont d'ordre 1 et ε^{-3} , respectivement, est considéré. Le solide est couchée par le fluide qui occupe un domaine épais. Le développement asymptotique complet est construit lorsque ε tend vers zéro. L'existence, la régularité et l'unicité de la solution pour le problème initial sont étudiées au moyen de techniques variationnelles. L'erreur de la méthode est évaluée.

Mots-clés : interaction fluide-structure, élasticité linéaire, équations de Stokes, fluide incompressible, interface, méthodes asymptotiques, modélisation, homogénéisation, traitement par laser, contraintes thermiques résiduelles, propriétés thermo-élastiques, fusion, la stabilité thermomécanique.

Abstract

The goal of this multi-disciplinary thesis is to study the fluid-structure interaction problem from mathematical and physical viewpoints. Viscous fluid-structure interaction problems describe, for example, interactions between the Earth mantle and the Earth crust, the blood and the vascular wall in a blood vessels, etc. In engineering viscous fluid-structure interaction appears during colloidal solution formation when a laser pierce through the fluid influencing the substrate (laser ablation in a liquid). Selective laser melting (SLM) is used to study the behavior of residual stresses depending on the thermoelastic and mechanical properties of the material and on various forms of reloaded beads. From mathematical point of view the coupled system “viscous fluid flow-thin elastic plate” in 3D when the thickness of the plate, ε , tends to zero, while the density and the Young’s modulus of the plate material are of order 1 and ε^{-3} , respectively, is considered. The plate lies on the fluid which occupies a thick domain. The complete asymptotic expansion is constructed when ε tends to zero. The existence, the regularity and the uniqueness of the solution for the original problem is studied by means of variational techniques. The error of the method is evaluated.

Key words : fluid-structure interaction, linear elasticity, Stokes equations, incompressible fluid, interface, asymptotic methods, modeling, homogenization, laser treatment, residual thermal stresses, thermoelastic properties, melting, thermomechanical stability.

Remerciements

Je garde un très bon souvenir de ma vie scientifique à Saint-Etienne. Je ne pourrai malheureusement pas citer toutes les personnes que je voudrais bien remercier ici, mais pourtant je prie d'agréer mes remerciements profonds à ceux qui ont été avec moi constamment ou juste un instant et qui ont apporté une contribution importante à ma vie durant ces années.

Mes premiers remerciements vont naturellement à mes directeurs de thèse, Grigory Panasenko et Andrey Gusarov. Il m'est difficile de devoir résumer en quelques lignes ma plus profonde gratitude et les sentiments que j'éprouve envers eux. Je tiens à adresser mes plus chaleureux remerciements à Grigory Petrovich pour les sujets intéressants qu'il m'a donnée et pour son encadrement tout au long de ma thèse. J'ai beaucoup appris grâce à lui, j'ai progressé avec ses conseils spacieux et données toujours au moment propice. Sa patience et ses connaissances m'ont constamment permise de grandir en sagesse, en science et en vie. Merci pour tout. Je tiens à remercier chaleureusement mon co-directeur de thèse Andrey Vladimirovich qui n'a eu de cesse de m'encourager et de me soutenir tout au long de la thèse. J'ai pu apprécier non seulement sa dimension physique et mathématique, mais aussi sa non moins importante dimension humaine. Sa manière de vivre et travailler m'a donnée un moyen exemplaire comment être en équilibre et faire mieux.

Tout d'abord, je souhaiterais remercier mes rapporteurs pour le temps qu'ils ont accordé à la lecture de cette thèse et à l'élaboration de leur rapport. Je remercie de tout mon cœur Ruxandra Stavre qui était pour moi une "co-directrice" parce qu'elle m'a découverte des fonds de l'analyse fonctionnel et variationnel et je sais gré à elle également pour sa disponibilité et sa gentillesse. Je lui suis reconnaissante du temps qu'elle m'a accordée. Je remercie Julia Orlik et Valeria

Chiadò Piat de m'avoir fait l'honneur de juger mon travail avec attention et des discussions agréables et très intéressantes sur des questions scientifiques et personnelles. Je tiens à remercier le Professeur Rachid Touzani pour accepter la présidence du comité d'examen de cette thèse et son accueil et son intérêt à mon travail.

Un grand merci également au Professeur Andrey Amosov de donner un autre état d'esprit lors de la recherche. Je mesure à sa juste valeur du temps qu'il m'accordée. Je lui remercie vivement d'être un maître à penser, un "co-directeur" pour moi.

Je remercie tout particulièrement les responsables du laboratoire ICJ UMR 5208 CNRS qui m'ont permis de m'intégrer rapidement et de réaliser mes projets, surtout Elisabeth Mironescu. Je remercie également l'UJM qui a financé cette thèse et mes déplacements en conférences, ainsi que les le personnel administratif, François Hennecart, Driss Essouabri, les employés de service ASTRE, qui, par leur accueil, ont contribué à mon initiation et à mon intégration dans ce monde de convivialité. Mes pensées se dirigent en particulier vers Pascale Villet.

J'aimerais ensuite proter de cette occasion à dire merci à Marie-Claude et Eric Canon, Frédéric Chardard, Laurence Grammont, Ilya Kostin, Laetitia Paoli et aux autres membres du laboratoire, où j'ai travaillé pendant ces trois ans. Merci à tous pour ces multiples discussions informelles, pour son accueil chaleureux.

Je dois de la gratitude à Alexander Elbert pour les discussions intéressantes en mathématiques. Ensuite, je remercie Imane, Roula, Domenico, Dalila, deux Hananes, Nohra et bien d'autres collègues de mon bureau à FST pour l'ambiance professionnelle et bienveillante, pour des moments de repos indispensables pour une expression scientifique complète. De plus, un grand merci à Varia, Irina, Eduard, Alexander, Natalia, petit Yaroslav, Olga qui ont partagé des moments agréables à Saint-Etienne.

C'est un honneur d'avoir connaissance avec Angelique Almeida, une technicienne informatique, très gentille et toujours prête à aider avec de nombreux problèmes qui peuvent arriver.

Je n'aurais peut-être jamais pu avoir la possibilité de travailler sur ma thèse, si mes parents ne m'avaient pas attaché de l'importance à l'étude. Je remercie ma

mère surtout pour son soutien moral extraordinaire, son optimisme et son amour.

Je tiens à honorer la mémoire de l'académicien de l'Académie des Sciences de Russie, Arlen Mikhailovich Il'in, dont j'ai eu de la chance d'être l'une de ses étudiantes. Je lui suis entièrement reconnaissante de m'avoir fait découvrir l'Analyse Asymptotique et la beauté, le sens, la passion de la recherche mathématique. Je n'oublierai jamais ses conseils avisés, son soutien colossal et sa disponibilité dans tous les questions ainsi professionnelles que personnelles. Cette thèse lui est dédiée.

Enfin, je souhaiterais remercier l'homme que je l'aime, mon mari, qui a fait tout ce qui était possible afin que j'écrive parfaitement la thèse. En étant un homme affectueux et compréhensif tout le temps, il a assuré mes derrières pendant cette période difficile. Je n'aurai jamais assez de mots pour le remercier.

Acknowledgements

I have very good memories of my scientific life in Saint-Etienne. Unfortunately, I will not be able to mention all people I would like to thank here, but even so I please accept my deepest thanks to those who have been with me constantly or just for a moment and who made a significant contribution to my life during these years.

My first thanks go to my course supervisors, Grigory Panasenکو and Andrey Gusarov. It is difficult to summarize in a few lines have my deepest gratitude and my feelings towards them. I wish to extend my warmest thanks to Grigory Petrovich for interesting topics that he has given me and for his guidance throughout my thesis. I learned a lot from him, I progressed with its spacious advices which were given always at the propitious moment of the time. His patience and knowledge have consistently allowed me to grow in wisdom, science and life. Thank you for everything. I would like to thank my co-supervisor Andrey Vladimirovich who never stopped encouraging me and supporting me throughout the thesis. I could appreciate not only its physical and mathematical dimension, but also its equally important human dimension. His way of life and work gave me a exemplary manner how to be balanced and do better.

Firstly, I would like to thank my reviewers for the time they have given to the reading of this thesis and the preparation of their report. I thank with all my heart Ruxandra Stavre which for me was a “co-director” because she discovered funds of the functional and variational analysis and I appreciate her also for her availability and her kindness to me. I am grateful for the time she has given me. I thank Julia Orlik and Valeria Chiadò Piat for giving me the honor to judge my work carefully and for pleasant and very interesting discussions on scientific and personal questions. I would like to thank Professor Rachid Touzani for accepting

the presidency of the examination committee of this thesis and his welcome and his interest in my work.

A big thank you also to Professor Andrey Amosov for give another mind-set when researching. I measure at fair value the time he gave me. I am grateful to him to be a mentor, a “co-director” for me.

I especially thank the officers of laboratory UMR 5208 CNRS ICJ who have allowed me to quickly integrate and realize my projects, especially Elisabeth Mironescu. I also thank the UJM that funded this thesis and my travel conferences, as well as administrative staff, Francois Hennecart, Driss Essouabri, AS-TRE employees, who, through their greeting, helped me with my initiation and integration in this world of friendliness. My thoughts go in particular to Pascale Villet.

Then I would like to take this opportunity to say thank you to Marie-Claude and Eric Canon, Frederick Chardard, Laurence Grammont, Ilya Kostin, Laetitia Paoli and other members of the lab, where I worked during these three years. Thank you all for the many informal discussions, for their warm welcome.

I owe gratitude to Alexander Elbert for interesting discussions in mathematics. Then, thank Imane, Roula, Domenico, Dalila, two Hananes, Nohra and many other colleagues in my office FST for professional and caring atmosphere for moments of rest required for a full scientific expression. In addition, a big thank you to Varia, Irina, Eduard, Alexander, Natalia, small Yaroslav, Olga who shared pleasant moments in Saint -Etienne.

It is an honor to be acquainted with Angelique Almeida, a computer technician, very kind and always ready to help with many problems that can happen.

I would perhaps never have had the opportunity to work on my thesis, if my parents had not tied my importance to the study. I especially thank my mother for her extraordinary moral support, optimism and love.

I want to honor the memory of Academician of the Academy of Sciences of Russia, Arlen Mikhailovich Il'in, which I was lucky to be one of his students. I am completely grateful to him for making me discover Asymptotic Analysis and beauty, meaning, passion for mathematical research. I will never forget his wise advices, his huge support and availability in all professional as well as personal

matters. This thesis is dedicated to him.

Finally, I would like to thank the man I love, my husband, who did everything possible so that I can write perfectly the thesis. Being a loving and understanding man all the time, he assured my rear during this difficult time. I will never have enough words to thank him.

Table des matières

Résumé	i
Abstract	iii
Remerciements	v
Acknowledgements	ix
Liste des figures	xvii
Liste des tableaux	xix
Introduction	1
1 Calcul des contraintes résiduelles sous fusion sélective au laser des poudres	9
1.1 Introduction	9
1.2 Modèle physique	12
1.3 Résultats	15
1.3.1 Plaque verticale	16
1.3.2 Plaque horizontale	17
1.3.3 Cordon sur un substrat semi-infini	18
1.4 Discussion	20
1.5 Analyse asymptotique du problème avec contraintes résiduelles dans le second-membre	26
1.5.1 Énoncé du problème	26
1.5.2 Existence et unicité d'une solution	27
1.5.3 Construction d'une solution	28

1.5.4	Justification du développement asymptotique	34
1.6	Conclusions	34
2	Analyse variationnelle du problème d'interaction d'un fluide visqueux avec une plaque mince	37
2.1	Introduction. Énoncé du problème	37
2.2	Existence et unicité d'une solution	45
2.2.1	Problème principal	45
2.2.2	Problème de limite	52
2.3	Résultats de régularité	57
2.3.1	Problème principal	57
2.3.2	Problème de limite	60
2.4	Conclusion	64
3	Analyse asymptotique du problème d'interaction d'un fluide visqueux avec une plaque mince	65
3.1	Introduction	65
3.2	Construction d'un développement asymptotique de la solution du problème	66
3.3	Justification du développement asymptotique et l'estimation d'erreur	96
3.4	Conclusion	103
	Conclusion	105
	Bibliographie	117

Contents

Résumé	i
Abstract	iii
Remerciements	v
Acknowledgements	ix
List of figures	xvii
List of tables	xix
Introduction	1
1 Calculation of residual stresses under selective laser melting of powders	9
1.1 Introduction	9
1.2 Physical model	12
1.3 Results	15
1.3.1 Vertical plate	16
1.3.2 Horizontal plate	17
1.3.3 Bead on a semi-infinite substrate	18
1.4 Discussion	20
1.5 Asymptotic analysis of the problem with residual stresses in the right-hand side	26
1.5.1 Statement of the problem	26
1.5.2 Existence and uniqueness of a solution	27
1.5.3 Construction of a solution	28

1.5.4	Justification of the asymptotic expansion	34
1.6	Conclusions	34
2	Variational analysis of a viscous fluid-thin plate interaction problem	37
2.1	Introduction. Formulation of the problem	37
2.2	Existence and uniqueness of a solution	45
2.2.1	Main problem	45
2.2.2	Limit problem	52
2.3	Regularity results	57
2.3.1	Regularity: main problem	57
2.3.2	Regularity: limit problem	60
2.4	Conclusion	64
3	Asymptotic analysis of a viscous fluid-thin plate interaction problem	65
3.1	Introduction	65
3.2	Construction of an asymptotic expansion of the solution to the problem	66
3.3	Justification of asymptotics and error estimation	96
3.4	Conclusion	103
	Conclusion	105
	Bibliography	117

List of Figures

1	Stress tensor	9
2	Vertical and horizontal plates grown on the substrate with the help of the SLM method	16
3	Individual remelted beads on a semi-infinite substrate	18
4	Dimensionless residual displacements, principal residual stresses and equivalent Mises stresses in the case of a remelted band	19
5	Dimensionless residual displacements, principal residual stresses and equivalent Mises stresses in the case of a lens-shaped remelted profile	20
6	Dimensionless residual displacements, principal residual stresses and equivalent Mises stresses in the case of a double-lens bead	21
7	Dimensionless residual displacements, principal residual stresses and equivalent Mises stresses in the case of a circle-shaped bead	22
8	Maximum principal residual stresses and the Mises stress in comparison with the limits of the tensile strength and yield limits	24
9	3D layer	38
10	Periodicity domain	42

List of Tables

1 Thermoelastic and mechanical properties of different materials
adopted for calculations. 25

Introduction

Des problèmes d'interaction d'un fluide visqueux avec une structure élastique décrivent, par exemple, des interactions entre le manteau terrestre et de la croûte terrestre, le sang et la paroi vasculaire dans un vaisseau sanguin, la mince croûte de glace et l'eau. Il existe un grand nombre d'articles sur le sujet [1–22] et d'autres. Aussi, en génie l'interaction fluide visqueux-structure apparaît-elle lors de la formation de solution colloïdale. Plus précisément, un laser passe à travers le fluide influençant le substrat (ablation laser dans un liquide).

Problème aux limites élastique linéaire fournit l'informations complète sur les contraintes, déformations et déplacements [23] dans le matériau élastique considéré. Équations de Navier-Stokes [24] décrivent le mouvement des substances fluides newtoniens. Le système couplé d'équations pour les mouvements élastiques et fluides avec l'égalité des vitesses et des contraintes normales à l'interface représente un modèle pour le problème d'interaction entre un fluide visqueux et une structure.

En général, le système d'équations de la théorie de l'élasticité est donné dans le système de coordonnées de Lagrange et le système de Navier-Stokes est représenté dans le système de coordonnées d'Euler. Les auteurs [19, 25] ont obtenu des résultats profonds quand un petit paramètre ε est le rapport entre le rayon et la longueur du vaisseau, le flux est régi par une chute de pression en fonction du temps donné entre les frontières d'entrée et de sortie, la paroi vasculaire est flexible. Si l'épaisseur de la plaque élastique est négligeable par rapport à l'épaisseur du fluide visqueux, alors nous ne différencions pas des coordonnées lagrangiennes et euliennes. Dans ce cas, il est beaucoup plus facile de construire un développement asymptotique complet [1, 2].

Le sujet de la thèse est d'étudier le problème de l'interaction fluide-structure

à partir du point de vue mathématique et physique. On commence avec le calcul des contraintes résiduelles sous fusion sélective au laser des poudres dans le chapitre 1. On considère un système d'équations de l'élasticité en présence des contraintes résiduelles, engendrées par un gradient des températures dans un matériau composite. Le développement asymptotique de la solution est construit et justifié. Ce problème est lié à l'application "traitement de surface par laser", plus précisément, à la fusion sélective au laser (FSL) des poudres ayant des propriétés thermoélastiques et mécaniques. On étudie le comportement des contraintes résiduelles avec dépendance des paramètres du procédé : du coefficient de Poisson, du point de fusion, de la dilatation thermique, du module de Young, des formes variées des cordons rechargés. Le calcul fournit les contraintes résiduelles qui se seraient formées après refroidissement de la zone de traitement à l'état initial moyennant l'absence de déformation élastique et de défaillance à l'étape de refroidissement. Les résultats des calculs peuvent être utilisés pour évaluer la stabilité thermomécanique des matériaux dans la FSL. La représentation graphique des champs deux-dimensionnels est obtenue numériquement avec une base des données des propriétés thermoélastiques des matériaux métalliques, céramiques et polymères. Ces résultats sont publiés dans [26] et [27].

La première étape de la fusion sélective au laser tandis qu'un liquide en fusion contacte avec un substrat élastique est étudié plus minutieusement dans la partie mathématique de la thèse (i.e. chapitres 2 et 3). La partie inférieure (élastique) est modélisée de manière plus détaillée dans la partie mathématique. Chapitre 2 représente l'analyse variationnelle du système couplé décrivant l'interaction fluide visqueux-plaque mince élastique en 3D. Résultats d'existence, d'unicité et de régularité sont obtenus pour le problème principal et le problème de limite. La méthode de Galerkin est appliquée. On généralise l'investigation du problème d'interaction du fluide visqueux avec la plaque mince élastique en 2D [1, 2]. Une nouvelle idée est de considérer la même fonction pour la vitesse du fluide \mathbf{v}_ε et la vitesse dans la zone élastique $\frac{\partial \mathbf{u}_\varepsilon}{\partial t}$. Cela permet de réduire le volume de la preuve en utilisant un ensemble des approximations de Galerkin à la place de deux (pour le milieu liquide et le milieu élastique). Le problème de limite est le problème aux limites de Stokes avec la condition spécifique sur une partie de la frontière

correspondante à une paroi élastique. La dérivée seconde en temps est absente dans cette condition par laquelle la preuve en cas 3D se distingue de celle donnée dans [18]. Ce système signifie que la plaque s'est abâtardie en une paroi grâce au contraste des coefficients. On a obtenu la condition de transmission pour des équations de Stokes avec une paroi élastique.

Le noyau de la thèse est le chapitre 3 sur l'analyse asymptotique du problème de contact d'une plaque élastique stratifiée mince et rigide avec une couche de fluide. La force de masse appliquée à la plaque est supposée 1-périodique en variables "horizontales", et le petit paramètre, ε , est le rapport des épaisseurs de la plaque et de la couche du fluide. On suppose que l'épaisseur de celle-ci est de même ordre que la période de la force appliquée. Toutes les constantes physiques (la viscosité, la densité, le temps caractéristique) sont eux aussi d'ordre 1, tandis que le module de Young de la plaque est d'ordre ε^{-3} . Ce problème modélise l'interaction flux visqueux-parois élastique dans plusieurs applications, comme par exemple, l'écoulement du sang, transport du pétrole, etc.

Donc, il ya deux "zooms" mathématiques sur la solution physique et numérique du problème : l'un parmi eux quand tout a refroidi (Section 1.5) et l'autre cas, quand une partie est fondue (chapitres 2 et 3).

Introduction

Viscous fluid-structure interaction problems describe, for example, interactions between the Earth mantle and the Earth crust, the blood and the vascular wall in a blood vessels, the thin crust of ice and the water. There is a large number of articles on the subject [1–22] and others. Also, in engineering viscous fluid-structure interaction appears during colloidal solution formation. More precisely, a laser pierce through the fluid influencing the substrate (laser ablation in a liquid).

Linear elastic boundary value problem provides complete information about stresses, strains and displacements [23] in the considered elastic material. Navier-Stokes equations [24] describe the motion of Newtonian fluid substances. The coupled system of equations for elastic and fluid motions with the equality of velocities and normal stresses at the interface represents a model for viscous fluid-structure interaction problem.

Generally, the system of equations of elasticity theory is given in the Lagrangian coordinate system and the Navier-Stokes system is putted down in the Euler coordinate system. The authors [19, 25] obtained profound results performing coordinate system changing, when a small parameter ε is the ratio between the radius and the length of the vessel, the flow is governed by a given time-dependent pressure drop between the inlet and the outlet boundary, vessel wall is compliant. If the thickness of elastic plate is negligibly small as compared to the thickness of viscous fluid, then we do not differentiate the Lagrangian and the Euler coordinates. In this case it is a lot easier to construct a complete asymptotic expansion [1, 2].

The subject of the thesis is to study the fluid-structure interaction problem from mathematical and physical viewpoints. We start with calculation of residual stresses under selective laser melting of powders in Chapter 1. A system of equations of the elasticity with the presence of residual stresses caused by a

temperature gradient in a composite material is considered. The asymptotic expansion of the solution is constructed and justified. This problem is related to the application “surface laser treatment”, more specifically, to the selective laser melting (SLM) of powders having thermoelastic and mechanical properties. We study the behavior of residual stresses with dependency of the process parameters: the Poisson’s ratio, the melting point, the thermal expansion, the Young’s modulus, the various forms of reloaded beads. The calculation provides the residual stresses that may have formed after cooling down of the treatment area to the initial state upon the absence of elastic deformation and failure of the cooling down stage. Calculation results can be used to evaluate the thermomechanical stability of the materials in the SLM process. The graphical representation of the two-dimensional fields is obtained numerically with a database of thermoelastic properties of metallic, ceramic and polymer materials. These results were published in [26] and [27].

The first stage of selective laser melting while a liquid melt contacts with an elastic substrate is studied more minutely in the mathematical part of the thesis (i.e. Chapters 2 and 3). The bottom part (elastic) is modelled in more detail in the mathematical part. Chapter 2 represents the variational analysis of the coupled system describing the viscous fluid-thin elastic plate interaction in 3D. Existence, uniqueness and regularity results are obtained for the main and the limit problems. Galerkin’s method is applied. The investigation of the viscous fluid-thin elastic plate interaction in 2D [1, 2] is generalized here. A new idea is to consider one function for the fluid velocity \mathbf{v}_ε and the velocity in the elastic area $\frac{\partial \mathbf{u}_\varepsilon}{\partial t}$. This allows to reduce a proof volume using one set of Galerkin approximations in place of two (for the fluid and elastic mediums). The limit problem is the Stokes boundary value problem with the specific upper boundary condition corresponding to an elastic wall. The second derivative in time is absent in this condition in 3D-case which makes the proof be different from that given in [18]. This system means that the plate degenerated in a wall because of contrast coefficients. There was obtained the transmission condition for Stokes equations with an elastic wall.

The core of the thesis is the Chapter 3 on the asymptotic analysis of the contact problem of a thin elastic stratified plate with a fluid layer. The mass force

applied to the plate is assumed to be 1-periodic in “horizontal” variables, and the small parameter ε is the ratio of the elastic plate thicknesses to the fluid layer thicknesses. It is assumed that the latter is of the same order as the period of the applied force. All physical constants (the viscosity, the density, the characteristic time) are also of order 1, whereas the Young’s modulus of the plate is of order ε^{-3} . This problem models the viscous-elastic wall flow interaction in many applications, for example, the flow of blood, the oil transportation, etc.

So, there are two mathematical “zooms” on physical and numerical solution to the problem: one of them when all cooled down (Section 1.5) and another case, when one part is molten (Chapters 2 and 3).

Chapter 1

Calculation of residual stresses under selective laser melting of powders

1.1 Introduction

The basic concepts of the theory of elasticity are described in [23]. We are interested in the isotropic case (homogeneous solid) when three-dimensional stress state along the edges of the elementary cube isolated from the material is characterized by normal and tangential stresses (see Fig. 1).

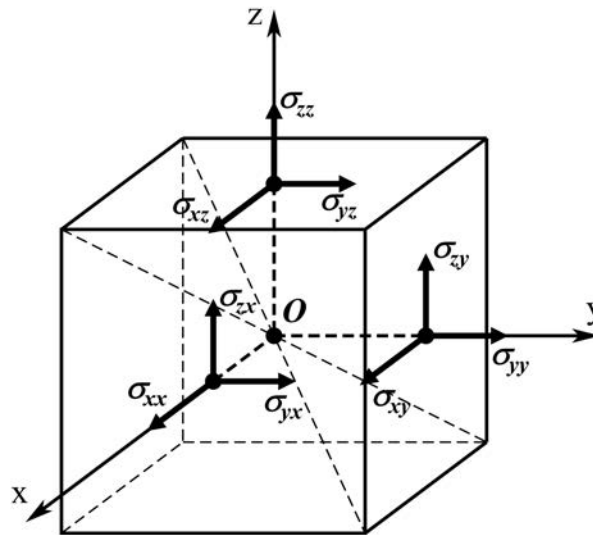

Fig. 1. Elementary cube with components of the stress state acting on the faces of the cube.

The principal stresses are normal stresses. Principal residual stresses for different materials are studied in this chapter. The results were in general published in [26] and [27].

Selective laser melting (SLM) is one of fast developing trends of additive tech-

nology. It is applied for rapid prototyping and manufacturing of functional parts from powders patterned after computer models. A part is shaped geometrically layer by layer, wherein mechanical deposition of thin flat layer powder is repeated several times (layer about 50 – 100 μm thick) and its selective scanning by a focused laser beam (spot diameter about 50 – 100 μm). In calculated for each computer patterned layer scanning zone, the powder is heated locally, resulting in its particles melted together along with the previously melted layer, forming a monolithic shape, dipped into granular powder. It remains only to remove the finished part of the technology container with the powder, and get the rest of it out of inside hollows. The details of SLM are described in monographs [28–33].

SLM method gives an opportunity to create parts of intricate shapes, which cannot be achieved through other technology, thus minimizing the demanding assembly. Shape correction requires interference only at the stage of computer modeling, which comes in handy while producing one-of-a-kind pieces and small batches. At this point high quality is achieved while using ductile metals and alloys, e.g. austenitic steel. Due to absence of pores and cracks and very fine grain structure of those materials, obtained through SLM, often have improved strength characteristics [29]. At the same time, SLM of more fragile materials may cause unacceptable cracking. For a long time the usage of high-strength titanium alloys Ti-6Al-4V type in this technology wasn't successful, although recently there has been some progress with this alloy [34].

A lot of technological parameters and wide diversity of materials employed along with economic factors, forcing to employ SLM only for one-of-a-kind pieces and small batches, put the issues of choice of stable processing modes and optimization at the top, which often take up a lot of production hours [35, 36]. Mathematical modeling is successfully applied for this [37]. The contemporary understanding of physics of laser radiation transport in powder layers and thermal processes at laser impingement point while SLM is reflected in works [28–30, 37]. Stability assessment issues of process and quality of micro- and macrostructure obtained through modeling are discussed in [38–43]. At the same time, the physics of residual stresses appearance, responsible for possible cracking and part shape deviation, is insufficiently studied.

The most general well-known method to reduce the residual stresses at a thermal treatment is to reduce the thermal gradient and the cooling rate [31–33,44]. This was confirmed, for example, at growing the monocrystals [45]. The same approach works at laser treatment [46,47], while it is difficult to implement because heating/cooling rate reduction means the proportional reducing of the productivity, and the reducing of the thermal gradient contradicts the local nature of the laser treatment. The preheating has recently become a universal method widely applied at the laser treatment [48,49]. In order to reduce residual stresses during SLM, the part formation is going on in a heated container [49]. Preheating efficiency is commonly explained by following two factors [50]. First, as the overall temperature difference in the treated part is decreased, the temperature gradients and the heating/cooling rates are proportionally decreased. Second, materials often become more plastic at elevated temperatures, so that thermal stresses can partially relax.

The conventional approach to calculate the residual stresses is to separate the thermal and the thermomechanical problems. The deformation due to the thermal expansion is usually small, so that its thermal effect is negligible compared to the laser energy. Therefore, the thermal problem can be considered independently. The temperature field and the shape of the melt pool calculated by the thermal model are the initial data for the thermomechanical model. Such a two-step scheme of calculation is useful to predict residual stresses for a given set of technological parameters [51,52], but can become too complicated for a theoretical parametric analysis and optimization of the technological process. A reasonable simplification of the thermomechanical model [53] was shown to be sufficient to construct a single-step calculation scheme independent of the temperature distribution and its evolution. Instead of the analysis in terms of the technological parameters, an analysis in terms of remelted profiles was proposed [53]. This method can be fruitful because the desired remelted profile is often given or the variety of acceptable profiles is restricted. In the scientific works [52,53] calculations are made for specific beads, obtained on a flat surface of half-infinite substrate, and in [51] for several beads paralleled upon one another and on the substrate. More complex geometries weren't considered. Calculations were made

for quartz glass and alumina and the capability to explain experimental data was shown [53]. Despite the demonstrated satisfying alignment of experiment results with the modeling [51–53] and the confirmation in [52,53] technique of preliminary heating for residual stress decrease, there is still an open issue of generalization of the results, obtained in the above mentioned works, for geometric shapes and materials, different from those mentioned in these works.

This work is based on the preceding works [51–53] and dedicated to development of more general technique of residual stresses assessment during SLM, applied to different materials (with arbitrary thermoelastic properties) and geometries.

1.2 Physical model

Strongly localized laser heating of the material generally leads to its expansion and compressive stresses appearance. With the passing of the laser beam, material compresses again and the appeared thermal stresses disappear. The practically observed formation of residual stresses as a result of thermal action is connected to full or partial relaxation of thermal stresses. With the cooling of the relaxation zone down to the initial temperature T_a , the stretching residual stresses are supposed to appear, and, in the surrounding material, compensating residual compressive stresses should be formed. Such distribution of residual stresses is in fact typical for laser processing. Therefore, classical thermoelastic medium model, useful for thermal stresses estimation, becomes completely inapplicable for residual stresses calculation.

The formation of residual stresses is often calculated after elastoplastic or viscoelastic medium models. The above mentioned works [51,52] are the examples of such approach. Aside from complexity of numerical calculations such models contain a lot of parameters, including parameters of the moving and nonstationary heating source, thermophysical properties of a medium, temperature dependence of the viscosity and the yield limit. That is why the results are hard to analyze and extrapolate to the unstudied materials. This decreases practical usefulness of such calculations. On the other hand, thermophysical and viscoelastoplastic properties of materials under high temperatures are often unknown or have a poor accuracy.

Also, the measurement error of residual stresses calculation, validating mathematical model, can significantly exceed the computational accuracy. Therefore, the detailed description with the help of thermoviscoelastoplastic models often becomes excessive in respect to laser processing, particularly SLM.

Alternative approach, suggested in [53], assumes explicit selection of thermal stresses relaxation zone while setting a problem. Given that laser melting and appearance of molten pool with free surface implies almost full stress relief in it, relaxation zone boundary may be defined in the thermal model as a boundary of maximum melting — the envelope of the melting front surface. The effective relaxation zone may considerably be larger than the remelting zone, provided that under elevated temperatures still in solid state affected by thermal stresses there is viscous and/or plastic flow. Then envelope of the generally transient isotherm of effective thermal stresses relaxation can be taken as the relaxation zone boundary. The advantage of such setting is the absence of a rigid connection between the heat and mechanical problems. For instance, in many types of laser processing the geometry of the remelted area or the area heated to a given temperature is set as the input data. Then the necessary parameter adjustment of the heat source is carried out by the thermal model, and residual stresses evaluation — by the mechanical model, which, in fact, becomes independent. Such separation of thermal and mechanical parameters may be useful for theoretical analysis.

More generally, the principal assumption made in the known model of residual stresses formation [53] consists in definition of a sharp boundary of the zone of complete relaxation of thermal stresses. After passage of the heat source and cooling down to the initial temperature, the relation between the tensors of stresses with components $\sigma_{\beta\gamma}$ and strains with components $\varepsilon_{\beta\gamma}$ outside the relaxation zone is given by the conventional generalized Hooke's law [23]

$$\sigma_{\beta\gamma} = \lambda\theta\delta_{\beta\gamma} + 2\mu\varepsilon_{\beta\gamma}, \quad (1.2.1)$$

where λ — is Lamé's first parameter, μ — the shear modulus, $\theta = \varepsilon_{xx} + \varepsilon_{yy} + \varepsilon_{zz}$ — the volumetric deformation, $\delta_{\beta\gamma}$ the Kronecker symbol, and indices β and γ take the values x , y and z , corresponding to the Cartesian axes.

Remark. This is equivalent to

$$\sigma_i^k = \sum_{j,l=1}^3 a_{ij}^{kl} \varepsilon_j^l, \quad \sigma_i^k = \sigma_{ik},$$

where the deformation is characterized by the vector field of displacement \mathbf{u} , with the strain tensor components given by derivatives

$$\varepsilon_j^l = \varepsilon_{jl} = \frac{1}{2} \left(\frac{\partial u_l}{\partial x_j} + \frac{\partial u_j}{\partial x_l} \right)$$

and elastic constants $a_{ij}^{kl} = \frac{E}{2(1+\nu)} \left(\frac{2\nu}{1-2\nu} \delta_{ik} \delta_{jl} + \delta_{ij} \delta_{kl} + \delta_{il} \delta_{jk} \right)$ verify standard properties:

(i) $a_{ij}^{kl}(x) = a_{kj}^{il}(x) = a_{ji}^{lk}(x) = a_{il}^{kj}(x)$, $\forall i, j, k, l \in \{1, 2, 3\}$, $\forall x \in \Omega$ (symmetry),

(ii) $\exists \varkappa > 0$ independent of ε such that $\sum_{i,j,k,l=1}^3 a_{ij}^{kl}(x) \eta_j^l \eta_i^k \geq \varkappa \sum_{j,l=1}^3 (\eta_j^l)^2$, $\forall x \in \Omega$,
 $\forall \eta = (\eta_j^l)_{1 \leq j, l \leq 3}$, with $\eta_j^l = \eta_l^j$ (coercivity).

Lamé's parameters λ and μ can be expressed in terms of E and ν , Young's modulus and Poisson's coefficient, respectively

$$\lambda = \frac{E\nu}{(1+\nu)(1-2\nu)}, \quad \mu = \frac{E}{2(1+\nu)}.$$

Another form is

$$\hat{\sigma}_j^l = a_{ij}^{kl} \frac{\partial u_l}{\partial x_j}.$$

The second assumption of the model is the elastic deformation inside thermal stresses relaxation zone while cooling. Thus, after cooling down to the initial temperature, the generalized Hooke's law inside this zone is written as [23]

$$\sigma_{\beta\gamma} = \lambda\theta\delta_{\beta\gamma} + 2\mu\varepsilon_{\beta\gamma} + 3sK\delta_{\beta\gamma}, \quad (1.2.2)$$

where K is the bulk modulus and s is the linear shrinkage while cooling from the thermal stresses relaxation temperature T_m down to the initial temperature T_a ,

which can be calculated according to linear thermal expansion coefficient α as

$$s = \int_{T_a}^{T_m} \alpha dT. \quad (1.2.3)$$

Relaxation temperature T_m can be evaluated either as melting temperature, or as softening point. Initial temperature T_a shall mean either the ambient temperature or the preheating one. The last term in the right hand side of equation (1.2.2) introduces isotropic tension in the relaxation zone. The value of this tension is chosen to compensate the thermal expansion at the relaxation temperature. Residual stresses, calculated by equation (1.2.2), as well as linear shrinkage (1.2.3) should be first and foremost checked according to inelastic strain and fracture criteria. Should the criteria be met, residual stresses shall be corrected accordingly.

In general, calculation according to the described model gives the residual stresses, which would be formed after cooling the treatment zone down to the initial state, if deformation at the cooling stage were strictly elastic. The possible influence of plastic flow and destruction at cooling should be taken into account separately. The application example presented further.

1.3 Results

Given that the SLM technology is designed for the manufacture of parts of intricate shapes, it is almost impossible to cover their potential variety, so in sections 1.3.1 and 1.3.2 only simple forms are observed, which, however, can be considered limiting due to the type of stress state. In section 1.3.3, the model is applied not to the part in whole, but to a separate bead on a flat surface of the thick substrate. These results are common, as the details of any forms are constructed from the beads of the same type, and allow us to estimate the residual stresses at the production stage. Under the substrate here we understand not only the substrate itself (on which the part is constructed), but also an array of the previous melted layers that constitute the already constructed part of the part.

1.3.1 Vertical plate

Vertical wall, grown on the substrate, as shown in Fig. 2 (a), serves as the model shape, used in the SLM experiments, and at the same time, it is a common element of various lightweight structures and surface reliefs. The whole body of the wall is made of remelted powder, so it can be considered a thermal stress relaxation area, and equation (1.2.2) can be applied to it. At the same time virtually the entire substrate remains unremelted and equation (1.2.1) operates in it. In case of a massive substrate, it prevents the wall from longitudinal deformation, that is why the longitudinal deformation is not present far away from the edges of the wall,

$$\varepsilon_{xx} = 0, \quad (1.3.1)$$

and away from the substrate there is no force acting in the transverse or vertical direction, so

$$\sigma_{yy} = \sigma_{zz} = 0. \quad (1.3.2)$$

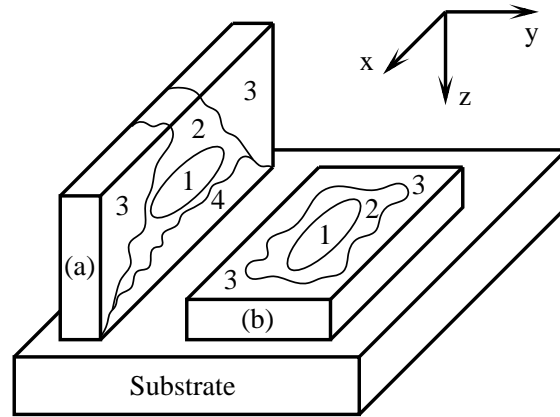

Fig. 2. Vertical (a) and horizontal (b) plates grown on the substrate with the help of the SLM method: 1 — computational domain; 2 — transition region; 3 — boundary zone of discharge; 4 — substrate influence zone; (XYZ) — Cartesian basis.

Arrangement of coordinate axes is given in Figure 2. Simultaneous solution of equations (1.2.2), (1.3.1) and (1.3.2) gives the longitudinal stress

$$\sigma_{xx} = sE, \quad (1.3.3)$$

where E is the Young's modulus.

Thus, the uniaxial tension is present in the computational domain of the vertical

wall. The computational domain is shown in Fig. 2 (a). The points of this domain must be spaced from the substrate by the distance much greater than the wall thickness, and from the vertical edges — by the distance much greater than the height of the wall. If for the plastic material the stress σ_{xx} , calculated according to equation (1.3.3), exceeds the yield limit, and the linear shrinkage s does not exceed the elongation at break, the plastic flow will lead to restriction of the longitudinal stress by the yield limit value. In case of a brittle material, equation (1.3.3) can be used up to the tensile strength rupture limit. The resulting stresses in the vertical wall can be used for evaluating the possibility of its failure while constructing by the SLM method, and also for calculating the bending of the substrate, as it is important in selecting its thickness.

1.3.2 Horizontal plate

Horizontal plate on the substrate, as shown in Fig. 2 (b), simulates a coating, or an extended low part. As in the previous case, the hard substrate prevents the transversal displacement, that is why far from the edges of the plate

$$\varepsilon_{xx} = \varepsilon_{yy} = 0, \quad (1.3.4)$$

and the free upper surface eliminates forces in the vertical direction, so

$$\sigma_{zz} = 0. \quad (1.3.5)$$

Simultaneous solution of equations (1.2.2), (1.3.4) and (1.3.5) gives the stress

$$\sigma_{xx} = \sigma_{yy} = \frac{sE}{1 - \nu}, \quad (1.3.6)$$

where ν is the Poisson's ratio.

This way the horizontal plate grown on a hard substrate is exposed to the isotropic biaxial tension. Since the Poisson's ratio is in the range from 0 to 1/2, the value of tensile stress is greater than in the vertical plate. The result is applicable to the computational domain shown in Fig. 2 (b), provided the elastic deformation during cooling. Adjustment for the possible plastic flow and the brittle fracture is the same as for the vertical plate, described in the previous

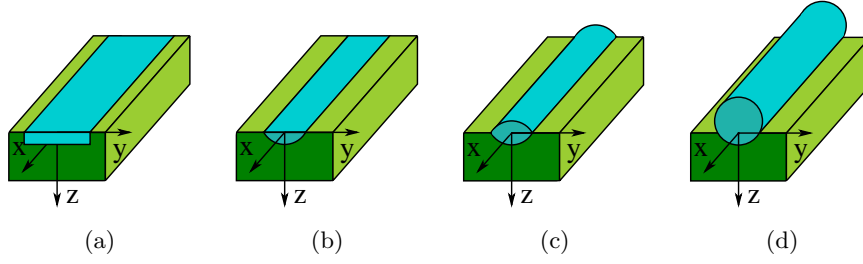

Fig. 3. Individual remelted beads on a semi-infinite substrate: remelted band (a); lens-shaped remelted profile (b); double-lens bead (c); circle-shaped bead (d)

section.

1.3.3 Bead on a semi-infinite substrate

Typical for the SLM configurations of the remelted beads are shown in Figure 3. The first configuration (3a) presents the shallow remelted band of finite width and infinite length on the surface of the half-space substrate. Material parameters are listed in Table 1. It is important that the lower part of the bead comes into the substrate, providing the metallurgical contact of the remelted powder with the substrate. Geometry (3b) corresponds to the extremely low amount of powder, as compared to the remelted substrate material, and in geometries (3c) and (3d) the proportion of the powder is increased successively. In the direction of the bead the problem is uniform and there is no displacement of the medium. Strain tensor is expressed through the displacement vector in the plane (YZ), $\mathbf{u} = (u_y, u_z)$:

$$\varepsilon_{xx} = \varepsilon_{xy} = \varepsilon_{xz} = 0, \quad \varepsilon_{yy} = \frac{\partial u_y}{\partial y}, \quad \varepsilon_{zz} = \frac{\partial u_z}{\partial z}, \quad \varepsilon_{yz} = \frac{1}{2} \left(\frac{\partial u_y}{\partial z} + \frac{\partial u_z}{\partial y} \right). \quad (1.3.7)$$

In the general case, the three components of the displacement vector are to be found from the system of the three force balance equations. In the considered below case of a uniform in x -direction remelted profile, $u_x = 0$, and the following two force balance (in the directions y and z) equations are sufficient:

$$\frac{\partial \sigma_{yy}}{\partial y} + \frac{\partial \sigma_{yz}}{\partial z} = 0, \quad \frac{\partial \sigma_{zz}}{\partial z} + \frac{\partial \sigma_{yz}}{\partial y} = 0, \quad (1.3.8)$$

substitution of the Hooke's law in which in the form of (1.2.1) or (1.2.2) results in a system of equations for the displacement \mathbf{u} . Example of the numerical solution of this system for the configurations shown in Fig. 3 (a–d) is given in Fig. 4–7,

respectively. The equivalent Mises stress is calculated by the formula

$$\sigma_{Mises} = \sqrt{\frac{1}{2} [(\sigma_1 - \sigma_2)^2 + (\sigma_1 - \sigma_3)^2 + (\sigma_2 - \sigma_3)^2]}, \quad (1.3.9)$$

where σ_1 , σ_2 and σ_3 are the principal stresses.

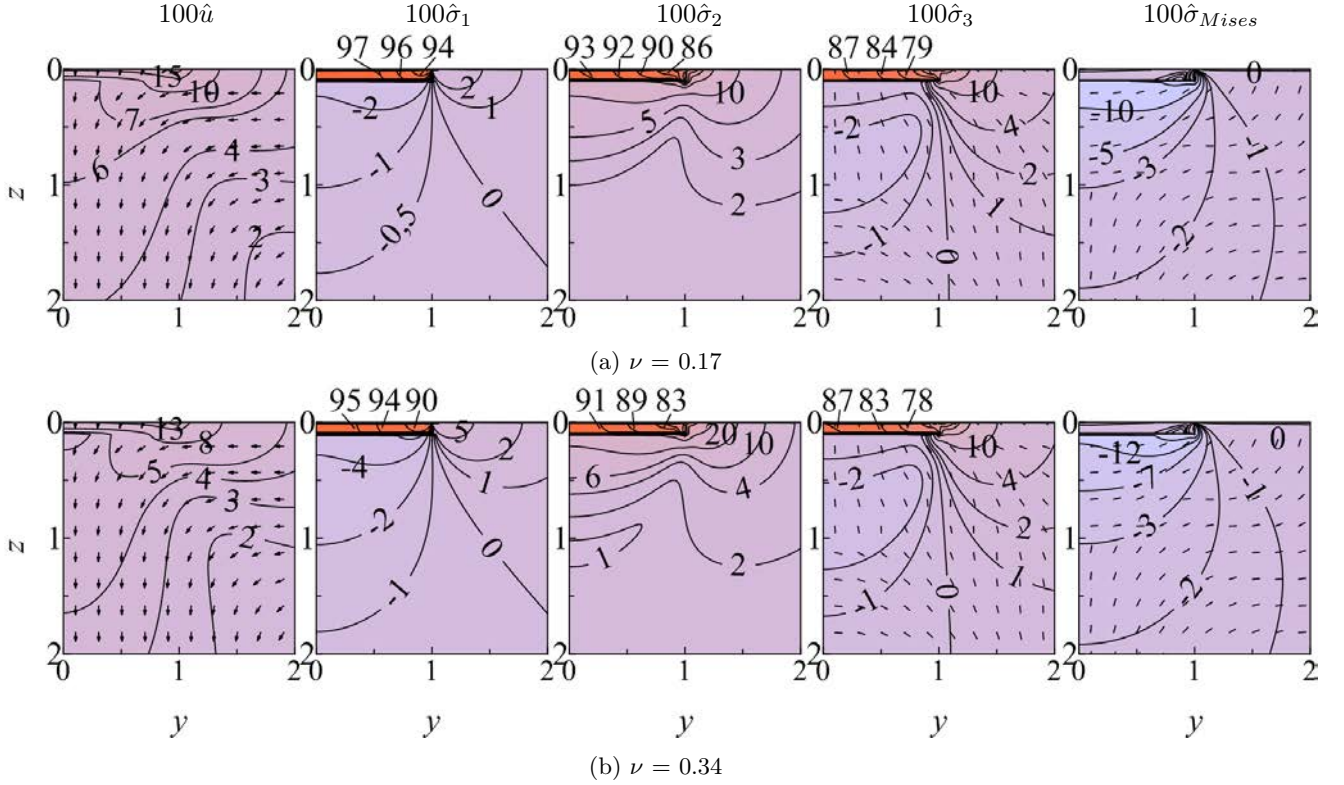

Fig. 4. Dimensionless residual displacements \hat{u} , principal residual stresses $\hat{\sigma}_1 = \hat{\sigma}_{xx}$, $\hat{\sigma}_2$, and $\hat{\sigma}_3$ and equivalent Mises stresses $\hat{\sigma}_{Mises}$ in remelted band with the configuration shown in Fig. 3a, and in the substrate adjacent areas for the Poisson's ratios $\nu = 0.17$ (a) and 0.34 (b). The displacement direction is indicated by the arrows. The principal axes directions in the plane (YZ) are shown by the dashes.

The non-dimensional values here are calculated using the following formulas:

$$\hat{\mathbf{u}} = \frac{\mathbf{u}}{u_0}, \quad \hat{\sigma}_{\beta\gamma} = \frac{\sigma_{\beta\gamma}}{\sigma_0}, \quad (1.3.10)$$

where the normalizing values of displacement u_0 and stress σ_0 correspond to the maximum values of these quantities in the horizontal plate of the unit thickness:

$$u_0 = \frac{1 + \nu}{1 - \nu}s, \quad \sigma_0 = \frac{sE}{1 - \nu}. \quad (1.3.11)$$

The above example of calculation for quartz glass suggests that the principal dependencies on the thermoelastic parameters are given by (1.3.11). Indeed, the dimensional analysis of the model equations indicates that dimensionless distributions (1.3.10) are functions of Poisson's ratio ν for a given shape of the remelted

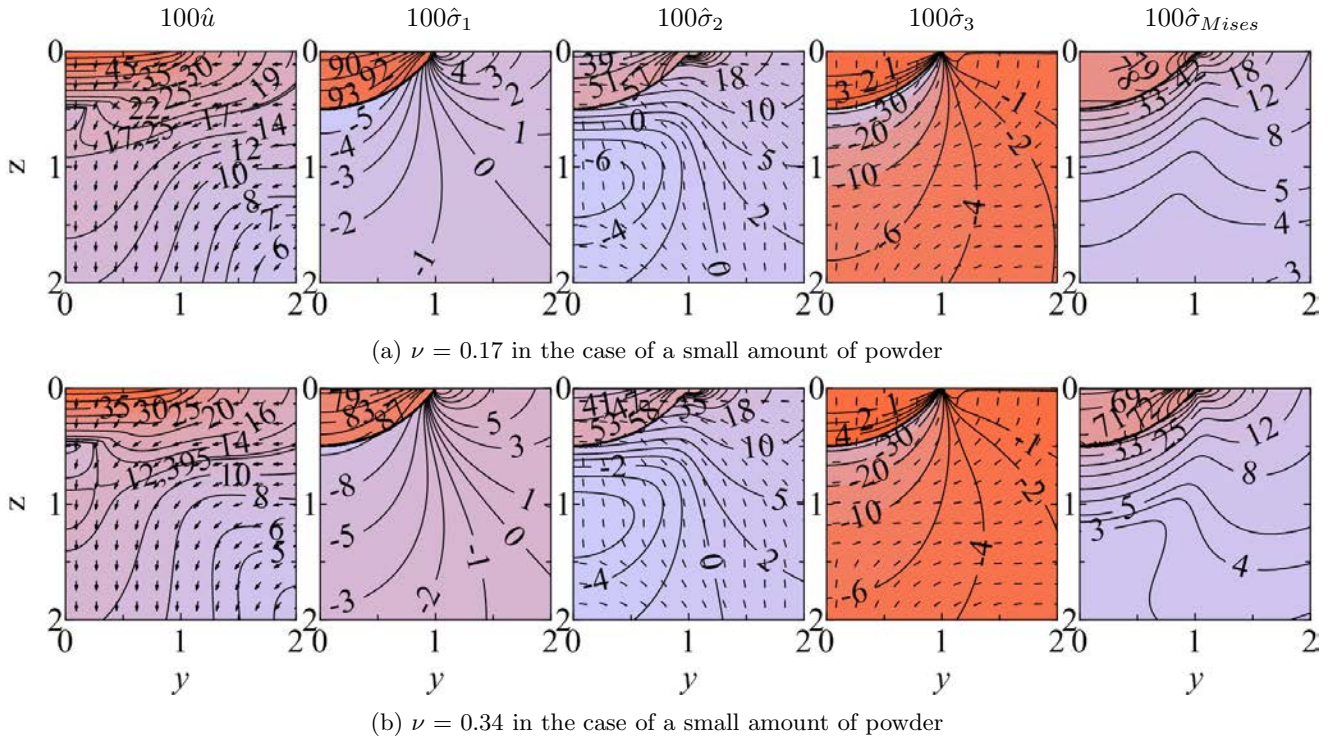

Fig. 5. Dimensionless residual displacements \hat{u} , principal residual stresses $\hat{\sigma}_1 = \hat{\sigma}_{xx}$, $\hat{\sigma}_2$, and $\hat{\sigma}_3$ and equivalent Mises stresses $\hat{\sigma}_{Mises}$ in insulated remelted beads with the configuration shown in Fig. 3b, and in the substrate adjacent areas for the Poisson's ratios $\nu = 0.17$ (a) and 0.34 (b). The displacement direction is indicated by the arrows. The principal axes directions in the plane (YZ) are shown by the dashes.

domain. In addition, the thermoelastic problem does not contain a characteristic space size. Therefore, the similar remelted domains of different scale form the similar displacement and stress fields.

Thermoelasticity problem does not contain the characteristic size, so the coordinates in Fig. 4, 5, 6 and 7 are given in arbitrary units. In the same units both \mathbf{u} and u_0 are measured.

1.4 Discussion

Comparison of the relevant non-dimensional epures for isolated beads in Fig. 5a and 5b and also Fig. 6a and 6b obtained at various Poisson's ratios does not show neither qualitative nor quantitative significant differences between them. This suggests that the main dependence on Poisson's ratio in the geometry of the insulated bead is the same as for the horizontal plate, and is given by equations (1.3.11). It can be also seen that the values of stresses in the region below the surface of the substrate, which are critical for the destruction and plastic flow,

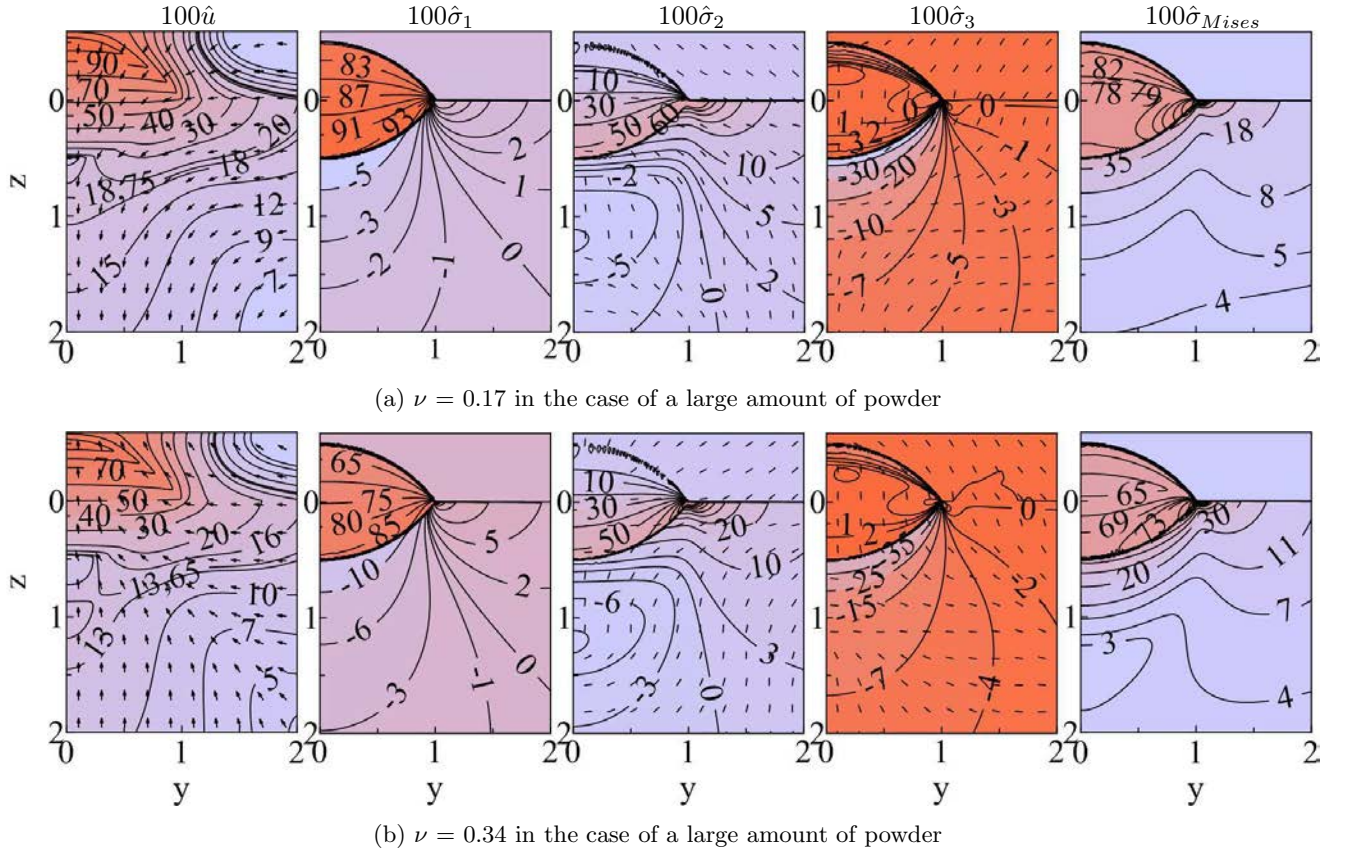

Fig. 6. Dimensionless residual displacements \hat{u} , principal residual stresses $\hat{\sigma}_1 = \hat{\sigma}_{xx}$, $\hat{\sigma}_2$, and $\hat{\sigma}_3$ and equivalent Mises stresses $\hat{\sigma}_{Mises}$ in insulated remelted beads with the configuration shown in Fig. 3c, and in the substrate adjacent areas for the Poisson's ratios $\nu = 0.17$ (a) and 0.34 (b). The displacement direction is indicated by the arrows. The principal axes directions in the plane (YZ) are shown by the dashes.

are weakly dependent on the bead height above the surface. Thus the conclusion of the work [53], obtained for the quartz glass, can be generalized.

Conventional methods of reducing the residual stresses in case of the SLM, such as preheating and the choice of material with less thermal expansion, elastic modulus, or melting point result from equations (1.3.3) and (1.3.6), and from the second equation (1.3.11). It can be also seen that the increase of the Poisson's ratio is advantageous for reducing residual stresses in the individual beads and the horizontal plate. At the same time, the results of this work indicate that the residual stresses are not dependent on the spatial resolution and, hence, on the temperature gradient. The cooling rate is also not among the parameters of the model. Therefore, it seems that these findings contradict the lessons learned. Though that is not quite true. For example, preheating decreases the total temperature difference in the part and thus reducing the gradient and the cooling rate.

(a) $\nu = 0.17$ in the case of a very large amount of powder(b) $\nu = 0.34$ in the case of a very large amount of powder

Fig. 7. Dimensionless residual displacements \hat{u} , principal residual stresses $\hat{\sigma}_1 = \hat{\sigma}_{xx}$, $\hat{\sigma}_2$, and $\hat{\sigma}_3$ and equivalent Mises stresses $\hat{\sigma}_{Mises}$ in insulated remelted beads with the configuration shown in Fig. 3d, and in the substrate adjacent areas for the Poisson's ratios $\nu = 0.17$ (a) and 0.34 (b). The displacement direction is indicated by the arrows. The principal axes directions in the plane (YZ) are shown by the dashes.

Model equation (1.2.2) implies that within the elastic deformation residual stresses are proportional to the linear thermal shrinkage s , which is roughly proportional to the temperature difference of the processed part in accordance with equation (1.2.3). In conventional furnace technologies of heat treatment this temperature difference is not fixed, but it is known that it is proportional to the temperature gradient in heterogeneous processes and the rate of heating/cooling in nonstationary processes. Therefore it is necessary to analyze these two parameters. In the laser technologies with their highly localized heating, the temperature

gradient is almost always known in advance and is equal to $T_m - T_a$, that is why it is easier to work with one parameter — s . Thus, the conclusion about the independence of residual stresses in the SLM on the temperature gradient and cooling rate made in [53] for quartz glass and generalized here for arbitrary materials within their elastic deformation during cooling should be seen not as a contradiction to previous experience, but rather as a proposal to use during the analysis of laser technologies only one parameter instead of two — the complete linear thermal shrinkage s .

Conclusion [53] that the maximum longitudinal tensile residual stresses in the individual beads are approximately twice as large as the maximum transverse and confirmed for phosphate glass ones [54], are generalized here to arbitrary materials having a Poisson's ratio in the investigated range from 0.17 to 0.34 within their elastic deformation during cooling after laser manufacturing.

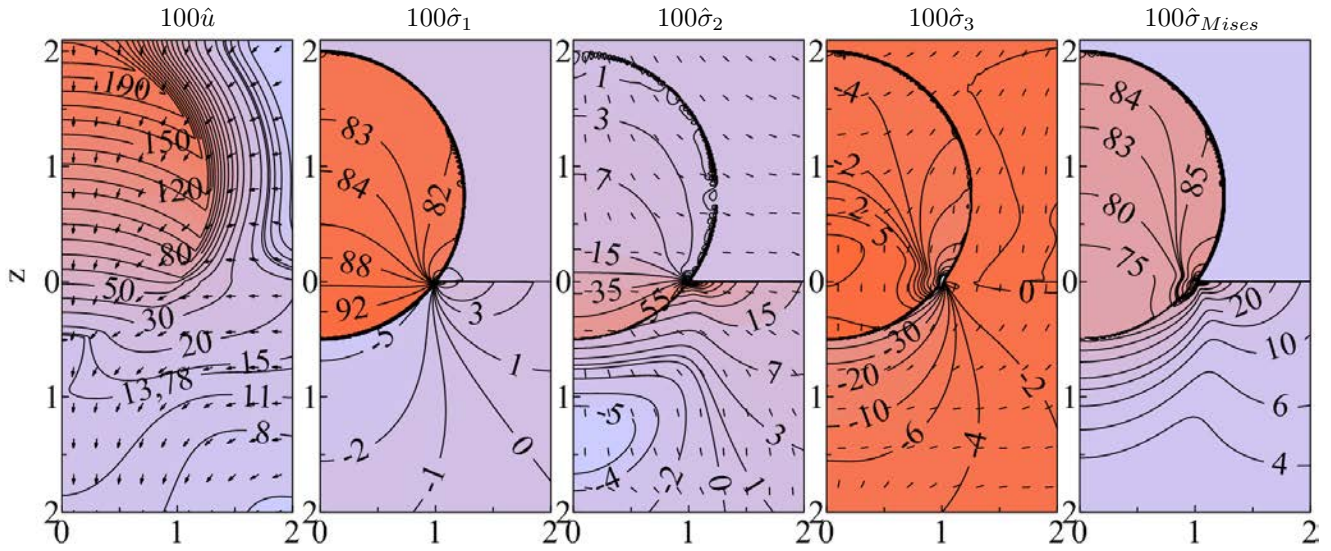
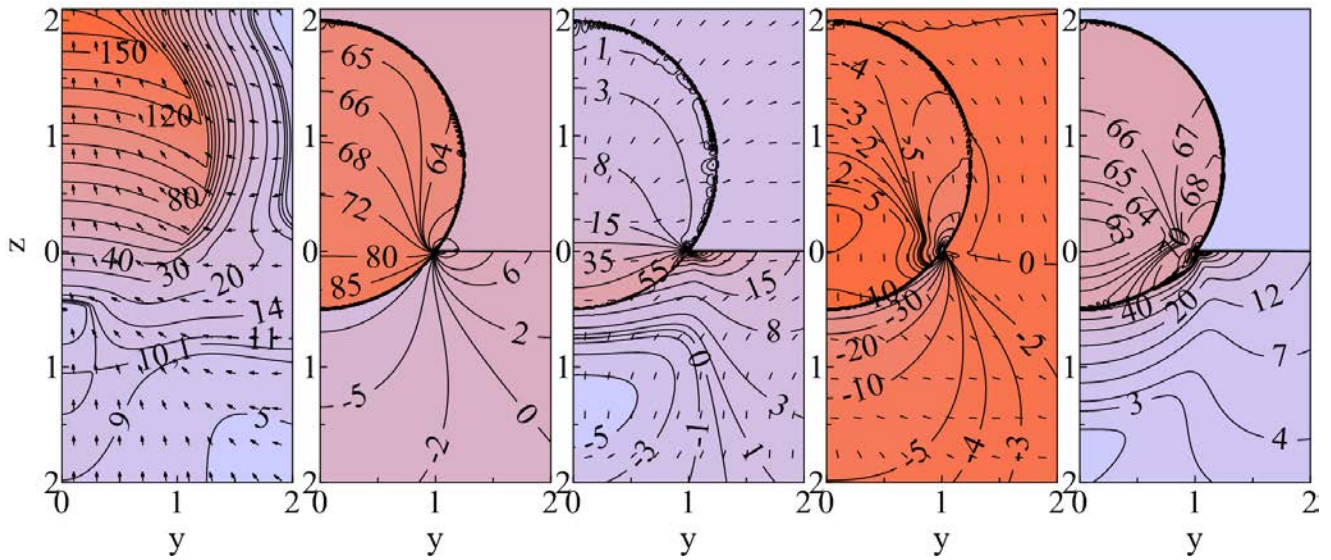
Stress distributions for three different geometries of the individual bead on a massive substrate shown in Figure 3, are very close. In contrast, in the vertical and horizontal plates shown in Figure 2, residual stresses are very different. Thus the question arises of how the fundamentally different stress states of parts constructed from individual beads are formed from the locally identical stress states at the stage of these beads. Model does not give an answer to it, as it is not considering the consecutive imposition of beads on each other. It can only be stated that the mechanical interaction of the part with the substrate on which it is built is crucial.

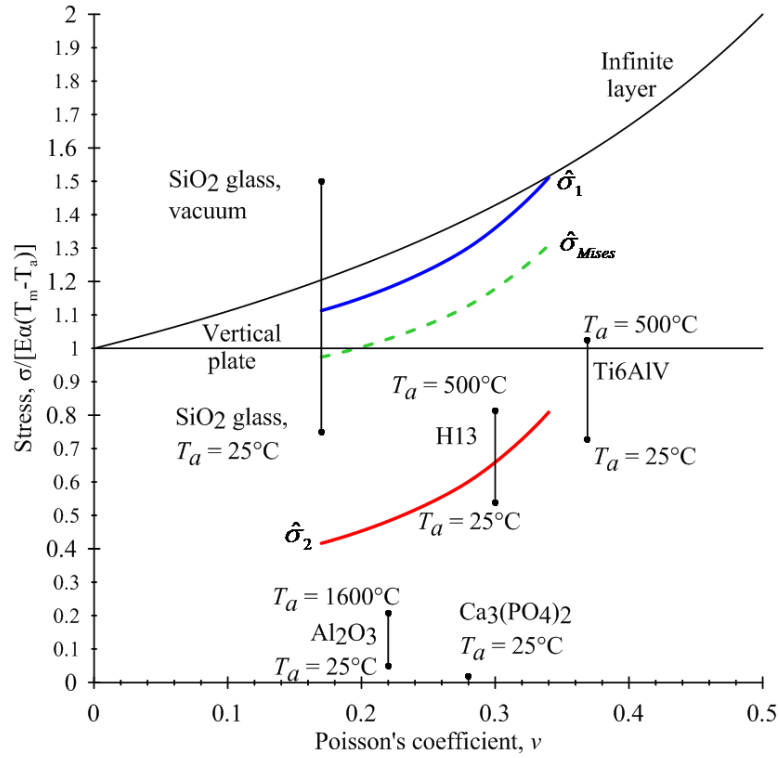

Fig. 8. Maximum principal tensile residual stresses, σ_1 and σ_2 , and the equivalent Mises stress σ_{Mises} in the individual beads (bold lines) and the maximum tensile residual stresses in the horizontal and vertical plates (thin lines) in comparison with the limits of the tensile strength of non-metallic materials and yield limits of the metallic ones (points). Preheating temperatures T_a are indicated near the points.

In Figure 8 the calculated residual stresses are compared to the tensile strength rupture limit of non-metallic materials and the yield limits of the metallic ones. The assumed values of material properties are given in Table 1. Stresses in Fig. 8 were made dimensionless involving a complete linear shrinkage s , which is dependent on the preheating temperature T_a . This eliminates the temperature dependence of the calculations that are shown as lines and artificially introduces the dependency of the dimensionless strength limits (shown by dots) on it. That is why for each point the value T_a is mentioned.

Material	ν	μ (GPa)	α (10^{-6}K^{-1})	T_m ($^{\circ}\text{C}$)	Tensile strength (MPa)	Yield limit (MPa)
Quartz glass	0.17	31	0.55	1700	50	
SiO ₂ , vacu- um grade	0.17	31	0.55	1700	100	
Al ₂ O ₃	0.22	150	8.4	2070	300	
Ca ₃ (PO ₄) ₂	0.28	19.5	10.9	1670	15	
H13	0.3	81	10.4	1427		1650
Ti-6Al-4V	0.34	42	7.6	1650		1030
Polystyrene	0.35	1.3	80	90	60	

Tab. 1. Thermoelastic and mechanical properties of different materials adopted for calculations.

Calculations for vertical plate in which the uniaxial tension is formed, can be directly compared with the results of uniaxial mechanical tests. For individual beads on a massive substrate the Mises equivalent stress is calculated as shown in Fig. 8 by the dashed line. Usage of other failure criteria or plastic flow under complex stress state is also not excluded as the principal stresses are given. In case of biaxial isotropic tension in the horizontal plate the Mises stress is equal to the stress along any of the equivalent axes in the plane of stretching.

The calculations predict the alumina oxide fracturing, even with the preheating up to 1600 $^{\circ}\text{C}$, and absence of polystyrene fracturing. This corresponds to the known SLM practice. The fracturing of the volumetric quartz glass parts is also expected, but without longitudinal cracks in the individual beads thereof. However, in this experiment [53] neither longitudinal nor transverse fracturing of the beads from this material was observed. This suggests its possible strengthening by rapid cooling after laser treatment. As for the high-impact metal alloys Ti-6Al-4V and H13, it is likely that the residual stresses in them reach the yield limits. This conclusion may be affected by the preheating and possible laser strengthen-

ing that is associated with grain refinement to submicron size characteristic for SLM [37].

Titanium alloys fracturing in the SLM is known to be prevented by processing in a protective atmosphere, eliminating oxidation [37]. That is why the mechanisms of its fracturing are not under consideration. Only the question about the ratio of elastic and plastic residual deformations is actual. Calculations shown in Fig. 8 suggest that the elastic and plastic deformation components depending on the particular geometry and on the preheating temperature are generally comparable. The same can be said about the ratio of elastic and plastic deformations in the H13 steel.

Thus, the above calculation results may be used to estimate the thermomechanical stability of materials in the SLM.

1.5 Asymptotic analysis of the problem with residual stresses in the right-hand side

1.5.1 Statement of the problem

Let G be limited (or confined) s -measured domain with infinitely smooth boundary ∂G . Consider the system of the conductivity equations

$$L_\varepsilon \mathbf{u} \equiv \sum_{k,j=1}^s \frac{\partial}{\partial x_k} \left(A_{kj} \left(\frac{x}{\varepsilon} \right) \frac{\partial \mathbf{u}}{\partial x_j} \right) = \mathbf{f}_0(x) + \nabla \left(\alpha \left(\frac{x}{\varepsilon} \right) \mathbf{T} \left(x, \frac{x}{\varepsilon} \right) \right), \quad (1.5.1)$$

with boundary condition

$$\mathbf{u} \text{ is } 1 - \text{ periodic in } \mathbb{R}^s. \quad (1.5.2)$$

Here $\varepsilon > 0$ is a small parameter, which is the characteristic scale of microstructure of the environment. We require that ε^{-1} be an integer. Also $x = (x_1, x_2, \dots, x_s) \in \mathbb{R}^s$, $\mathbf{u} = \mathbf{u}(x_1, x_2, \dots, x_s) = (\mathbf{u}_1, \mathbf{u}_2, \dots, \mathbf{u}_s)$ — temperature, $\mathbf{f}_0 = (\mathbf{f}_0^1, \mathbf{f}_0^2, \dots, \mathbf{f}_0^s)$, $A_{ij}(\xi)$ are periodic with respect to all variables ξ_i with period 1 ($s \times s$) matrix-functions describing heat-conducting properties of the material and satisfying properties (i) and (ii) p. 14, where $\xi_i = \varepsilon^{-1}x_i$, $\forall i = 1, \dots, s$, $\xi = (\xi_1, \xi_2, \dots, \xi_s) = (\varepsilon^{-1}x_1, \varepsilon^{-1}x_2, \dots, \varepsilon^{-1}x_s)$.

The external force $\mathbf{f}_0(x)$ has zero averaged value:

$$\langle \mathbf{f}_0(x) \rangle = 0; \quad (1.5.3)$$

where $\langle \cdot \rangle = \int_{(0,1)^s} d\xi$.

The thermal expansion coefficient $\alpha(\frac{x}{\varepsilon})$ is a measurable bounded function on $[0, 1]$, the temperature $\mathbf{T}(x, \frac{x}{\varepsilon})$ has the following structure

$$\mathbf{T}(x, \frac{x}{\varepsilon}) = \mathbf{T}_0(x) + \varepsilon \mathbf{T}_1(x, \frac{x}{\varepsilon}),$$

where the solution of the homogenized thermal conductivity equation $\mathbf{T}_0(x)$ is known function and the first corrector of the thermal conductivity is represented in the form

$$\mathbf{T}_1(x, \frac{x}{\varepsilon}) = \sum_{i=1}^s N_i(\xi) \frac{\partial \mathbf{T}_0(x)}{\partial x_i}, \quad (1.5.4)$$

as it was introduced by N.S. Bakhvalov and G.P. Panasenko in [55].

$A_{ij}(\xi)$, $\mathbf{f}_0(x)$, $\mathbf{T}_0(x)$, $\mathbf{T}_1(x, \frac{x}{\varepsilon})$ are infinitely differentiable functions in \mathbb{R}^s .

We assume that elements of the matrices $A_{ij}(\xi)$ satisfy conditions:

$$a_{kj}^{il} = a_{ij}^{kl} = a_{kl}^{ij} = a_{jk}^{li}, \quad (1.5.5)$$

$$a_{kj}^{il}(\xi) \eta_{ik} \eta_{lj} \geq \varkappa \eta_{ik} \eta_{lk} \quad (1.5.6)$$

for any symmetrical matrix $\|\eta_{ik}\|$, where $\varkappa > 0$ is constant independent of ε .

It is necessary to construct the asymptotic of the solution of the problem at ε tending to zero.

1.5.2 Existence and uniqueness of a solution

Denote $G = (0, 1)^s$ and consider the spaces

$$\begin{aligned} H_{\#}^1(G) &= \left\{ f \in H_{loc}^1(\mathbb{R}^s) \mid f - 1\text{-periodic} \right\}, \quad \|f\|_{H_{\#}^1(G)} = \|f\|_{H^1(G)}, \\ L_{\#}^2(G) &= \left\{ f \in L_{loc}^2(\mathbb{R}^s) \mid f - 1\text{-periodic} \right\}, \quad \|f\|_{L_{\#}^2(G)} = \|f\|_{L^2(G)}. \end{aligned} \quad (1.5.7)$$

Definition 1.1. The weak solution to problem (1.5.1), (1.5.2) is called a function

$\mathbf{u} \in H_{\#}^1(G)$ which satisfies the following variational problem:

$$\left\{ \begin{array}{l} \text{Find } \mathbf{u} \in H_{\#}^1(G) \text{ such that} \\ - \int_G \sum_{k,j=1}^s A_{kj} \frac{\partial \mathbf{u}}{\partial x_j} \frac{\partial \varphi}{\partial x_k} = \int_G \mathbf{f}_0 \varphi - \int_G \alpha \mathbf{T} \nabla \varphi, \quad \forall \varphi \in H_{\#}^1(G). \end{array} \right. \quad (1.5.8)$$

Theorem 1.2. *Let $\mathbf{f}_0 \in L_{\#}^2(G)$, α and \mathbf{T} satisfy the properties indicated above (measurable bounded functions). In addition the averaged value $\langle \mathbf{u} \rangle = \mathbf{0}$ and $\langle \mathbf{f}_0 \rangle = \mathbf{0}$. Then there exists a unique solution to problem (1.5.8) that satisfies the following estimate*

$$\|\mathbf{u}\|_{H^1} \leq C (\|\mathbf{f}_0\|_{L^2} + \|\alpha \mathbf{T}\|_{L^2}), \quad (1.5.9)$$

with C a positive constant.

Proof. This is a classical result [55] that there exists a unique solution $\mathbf{u} \in H_{\#}^1(G)$ to problem (1.5.8).

A priori estimates can be easily obtained with help of Korn inequality [56] and Cauchy-Schwarz-Bunyakovsky inequality [57]. Namely,

$$\begin{aligned} \varkappa \|\nabla \mathbf{u}\|_{L^2}^2 &\leq \varkappa \left| \int_G \sum_{k,j=1}^s \frac{\partial \mathbf{u}}{\partial x_j} \frac{\partial \mathbf{u}}{\partial x_k} \right| \leq \left| \int_G \sum_{k,j=1}^s A_{kj} \frac{\partial \mathbf{u}}{\partial x_j} \frac{\partial \mathbf{u}}{\partial x_k} \right| \\ &\leq \|\mathbf{f}_0\|_{L^2} \|\mathbf{u}\|_{L^2} + \|\alpha \mathbf{T}\|_{L^2} \|\nabla \mathbf{u}\|_{L^2} \leq (\|\mathbf{f}_0\|_{L^2} + \|\alpha \mathbf{T}\|_{L^2}) \|\mathbf{u}\|_{H^1}, \\ \varkappa \|\nabla \mathbf{u}\|_{L^2}^2 &\leq (\|\mathbf{f}_0\|_{L^2} + \|\alpha \mathbf{T}\|_{L^2}) \|\mathbf{u}\|_{H^1}, \end{aligned}$$

and using the equivalence of $\|\nabla \mathbf{u}\|_{L^2}$ and $\|\mathbf{u}\|_{H^1}$:

$$\|\mathbf{u}\|_{H^1} \leq (1 + C^2) \|\nabla \mathbf{u}\|_{L^2} \leq (1 + C^2) \|\mathbf{u}\|_{H^1},$$

where $C > 0$ is the constant appearing in the Poincaré-Friedrichs' inequality [58] finally we get (1.5.9). \square

1.5.3 Construction of a solution

We introduce the following notation for the left-hand side of (1.5.1)

$$P\mathbf{u} \equiv \sum_{k,j=1}^s \frac{\partial}{\partial x_k} \left(A_{kj} \left(\frac{x}{\varepsilon} \right) \frac{\partial \mathbf{u}}{\partial x_j} \right), \quad x \in G. \quad (1.5.10)$$

We need to take into consideration that

$$\nabla = (\nabla_x + \varepsilon^{-1} \nabla_\xi) \Big|_{\xi=\frac{x}{\varepsilon}} \quad (1.5.11)$$

and that formula (1.5.4) is carried out. Then (1.5.10) becomes

$$\begin{aligned} P\mathbf{u} \equiv & \sum_{k,j=1}^s \left[\frac{\partial}{\partial x_k} \left(A_{kj}(\xi) \frac{\partial \mathbf{u}}{\partial x_j} \right) + \frac{1}{\varepsilon} \frac{\partial}{\partial \xi_k} \left(A_{kj}(\xi) \frac{\partial \mathbf{u}}{\partial x_j} \right) + \frac{1}{\varepsilon} \frac{\partial}{\partial x_k} \left(A_{kj}(\xi) \frac{\partial \mathbf{u}}{\partial \xi_j} \right) + \right. \\ & \left. + \frac{1}{\varepsilon^2} \frac{\partial}{\partial \xi_k} \left(A_{kj}(\xi) \frac{\partial \mathbf{u}}{\partial \xi_j} \right) \right] \end{aligned} \quad (1.5.12)$$

and the right-hand side is transformed as follows

$$\begin{aligned} \mathbf{f}_0(x) + \nabla \left(\alpha \left(\frac{x}{\varepsilon} \right) \mathbf{T} \left(x, \frac{x}{\varepsilon} \right) \right) &= \mathbf{f}_0(x) + \frac{1}{\varepsilon} \sum_{k=1}^s \mathbf{T}_0(x) \frac{\partial \alpha(\xi)}{\partial \xi_k} \\ + \sum_{j=1}^s \left(\alpha(\xi) + \sum_{k=1}^s \frac{\partial(\alpha N_j)}{\partial \xi_k} \right) \cdot \frac{\partial \mathbf{T}_0(x)}{\partial x_j} &+ \varepsilon \sum_{k,j=1}^s \alpha(\xi) N_j(\xi) \frac{\partial^2 \mathbf{T}_0(x)}{\partial x_k \partial x_j} \\ &= \mathbf{f}_0(x) + \sum_{l=0}^2 \varepsilon^{l-1} \sum_{|i|=l} G_i(\xi) D^i T_0, \end{aligned} \quad (1.5.13)$$

where it is denoted:

$$G_\emptyset = \frac{\partial \alpha(\xi)}{\partial \xi_k}, \quad G_{i_1} = \alpha(\xi) + \frac{\partial(\alpha N_j)}{\partial \xi_k}, \quad G_{i_1 i_2} = \alpha(\xi) N_j(\xi). \quad (1.5.14)$$

A formal asymptotic solution to problem (1.5.1), (1.5.2) is searched in the following form

$$\begin{aligned} u^{(K)} &= \sum_{l=0}^{K+1} \varepsilon^l \sum_{|i|=l} N_i \left(\frac{x}{\varepsilon} \right) D^i v^{(K)} + Y_{i-1} \left(\frac{x}{\varepsilon} \right) D^{i-1} T_0, \\ v^{(K)} &= \sum_{j=0}^K \varepsilon^j v_j(x), \end{aligned} \quad (1.5.15)$$

where $i = (i_1, \dots, i_l)$ is a multi-index, $i_j \in \{1, \dots, s\}$, $v(x)$ is a infinitely differentiable 1-periodic with respect to x_1, \dots, x_s vector function, $N_i(\xi)$, $Y_i(\xi)$ are $(s \times s)$ matrix functions that are 1-periodic with respect to ξ_1, \dots, ξ_s .

By substitution of series (1.5.15) instead of \mathbf{u} in (1.5.12) we obtain

$$\begin{aligned}
P\mathbf{u}^{(K)} &= \sum_{l=0}^{K+1} \varepsilon^l \sum_{|i|=l} \left(A_{kj}(\xi) N_i(\xi) \frac{\partial^2 D^i v^{(K)}}{\partial x_k \partial x_j} + A_{kj}(\xi) Y_{i-1}(\xi) \frac{\partial^2 D^{i-1} T_0}{\partial x_k \partial x_j} \right) + \\
&+ \varepsilon^{-1} \sum_{l=0}^{K+1} \varepsilon^l \sum_{|i|=l} \left(\frac{\partial}{\partial \xi_k} (A_{kj}(\xi) N_i(\xi)) \frac{\partial D^i v^{(K)}}{\partial x_j} + \frac{\partial}{\partial \xi_k} (A_{kj}(\xi) Y_{i-1}(\xi)) \frac{\partial D^{i-1} T_0}{\partial x_j} \right) + \\
&+ \varepsilon^{-1} \sum_{l=0}^{K+1} \varepsilon^l \sum_{|i|=l} \left(A_{kj}(\xi) \frac{\partial N_i(\xi)}{\partial \xi_j} \frac{\partial D^i v^{(K)}}{\partial x_k} + A_{kj}(\xi) \frac{\partial Y_{i-1}(\xi)}{\partial \xi_j} \frac{\partial D^{i-1} T_0}{\partial x_k} \right) + \\
&+ \varepsilon^{-2} \sum_{l=0}^{K+1} \varepsilon^l \sum_{|i|=l} \left(\frac{\partial}{\partial \xi_k} \left(A_{kj}(\xi) \frac{\partial N_i(\xi)}{\partial \xi_j} \right) D^i v^{(K)} + \frac{\partial}{\partial \xi_k} \left(A_{kj}(\xi) \frac{\partial Y_{i-1}(\xi)}{\partial \xi_j} \right) D^{i-1} T_0 \right),
\end{aligned}$$

After index changing

$$\begin{aligned}
r &= l + 2, \quad i_1 = k, \quad i_2 = l, \\
q &= l + 1, \quad i_1 = j, \\
q &= l + 1, \quad i_1 = k
\end{aligned} \tag{1.5.16}$$

in the first, the second and the third sum respectively we obtain:

$$\begin{aligned}
P\mathbf{u}^{(K)} &= \sum_{r=0}^{K+3} \varepsilon^{r-2} \sum_{|i|=r} \left(A_{i_1 i_2}(\xi) N_{i_3 \dots i_r}(\xi) D^i v^{(K)} + A_{i_1 i_2}(\xi) Y_{i_3 \dots i_{r-1}}(\xi) D^{i-1} T_0 \right) + \\
&+ \sum_{q=0}^{K+2} \varepsilon^{q-2} \sum_{|i|=q} \left(\frac{\partial}{\partial \xi_k} (A_{ki_1}(\xi) N_{i_2 \dots i_q}(\xi)) D^i v^{(K)} + \frac{\partial}{\partial \xi_k} (A_{ki_1}(\xi) Y_{i_2 \dots i_{q-1}}(\xi)) D^{i-1} T_0 \right) + \\
&+ \sum_{q=0}^{K+2} \varepsilon^{q-2} \sum_{|i|=q} \left(A_{i_1 j}(\xi) \frac{\partial N_{i_2 \dots i_q}(\xi)}{\partial \xi_j} D^i v^{(K)} + A_{i_1 j}(\xi) \frac{\partial Y_{i_2 \dots i_{q-1}}(\xi)}{\partial \xi_j} D^{i-1} T_0 \right) + \\
&+ \sum_{l=0}^{K+1} \varepsilon^{l-2} \sum_{|i|=l} \left(\frac{\partial}{\partial \xi_k} \left(A_{kj}(\xi) \frac{\partial N_i(\xi)}{\partial \xi_j} \right) D^i v^{(K)} + \frac{\partial}{\partial \xi_k} \left(A_{kj}(\xi) \frac{\partial Y_{i-1}(\xi)}{\partial \xi_j} \right) D^{i-1} T_0 \right),
\end{aligned}$$

and after identification of the indexes r, q, l :

$$P\mathbf{u}^{(K)} = \sum_{l=0}^{K+1} \varepsilon^{l-2} \sum_{|i|=l} \left(H_i(\xi) D^i v^{(K)} + S_{i-1}(\xi) D^{i-1} T_0 \right) + R_{1\varepsilon}^{(K)}, \tag{1.5.17}$$

where

$$\begin{aligned}
R_{1\varepsilon}^{(K)} &= \varepsilon^K \sum_{|i|=K+2} \left\{ \left(\frac{\partial}{\partial \xi_k} (A_{ki_1}(\xi) N_{i_2 \dots i_{K+2}}(\xi)) + A_{i_1 j}(\xi) \frac{\partial N_{i_2 \dots i_{K+2}}(\xi)}{\partial \xi_j} + \right. \right. \\
&\quad \left. \left. + A_{i_1 i_2}(\xi) N_{i_3 \dots i_{K+2}}(\xi) \right) D^i v^{(K)} + \left(\frac{\partial}{\partial \xi_k} (A_{ki_1}(\xi) Y_{i_2 \dots i_{K+1}}(\xi)) + \right. \right. \\
&\quad \left. \left. + A_{i_1 j}(\xi) \frac{\partial Y_{i_2 \dots i_{K+1}}(\xi)}{\partial \xi_j} + A_{i_1 i_2}(\xi) Y_{i_3 \dots i_{K+1}}(\xi) \right) D^{i-1} T_0 \right\} + \\
&+ \varepsilon^{K+1} \sum_{|i|=K+3} \left\{ A_{i_1 i_2}(\xi) N_{i_3 \dots i_{K+3}}(\xi) D^i v^{(K)} + A_{i_1 i_2}(\xi) Y_{i_3 \dots i_{K+2}}(\xi) D^{i-1} T_0 \right\}.
\end{aligned} \tag{1.5.18}$$

Remark. In (1.5.18)

$$\begin{aligned}
&\varepsilon^K \sum_{|i|=K+2} \frac{\partial}{\partial \xi_k} (A_{ki_1}(\xi) N_{i_2 \dots i_{K+2}}(\xi)) D^i v^{(K)} + \varepsilon^{K+1} \sum_{|i|=K+3} A_{i_1 i_2}(\xi) N_{i_3 \dots i_{K+3}}(\xi) D^i v^{(K)} = \\
&= \varepsilon^{K+1} \sum_{|i|=K+2} \left(\frac{1}{\varepsilon} \frac{\partial}{\partial \xi_k} (A_{ki_1}(\xi) N_{i_2 \dots i_{K+2}}(\xi)) D^i v^{(K)} + \frac{\partial}{\partial x_k} (A_{ki_1}(\xi) N_{i_2 \dots i_{K+2}}(\xi) D^i v^{(K)}) \right) = \\
&= \varepsilon^{K+1} \frac{\partial}{\partial x_k} \left(\sum_{|i|=K+2} A_{ki_1} \left(\frac{x}{\varepsilon} \right) N_{i_2 \dots i_{K+2}} \left(\frac{x}{\varepsilon} \right) D^i v^{(K)} \right)
\end{aligned}$$

and

$$\begin{aligned}
&\varepsilon^K \sum_{|i|=K+2} \frac{\partial}{\partial \xi_k} (A_{ki_1}(\xi) Y_{i_2 \dots i_{K+1}}(\xi)) D^{i-1} T_0 + \varepsilon^{K+1} \sum_{|i|=K+3} A_{i_1 i_2}(\xi) Y_{i_3 \dots i_{K+2}}(\xi) D^{i-1} T_0 = \\
&= \varepsilon^{K+1} \frac{\partial}{\partial x_k} \left(\sum_{|i|=K+2} A_{ki_1} \left(\frac{x}{\varepsilon} \right) Y_{i_2 \dots i_{K+1}} \left(\frac{x}{\varepsilon} \right) D^{i-1} T_0 \right).
\end{aligned}$$

There are at $|i| = 0$:

$$H_{\emptyset} = L_{\xi\xi} N_{\emptyset} \equiv 0, \quad N_{\emptyset} = 1,$$

at $|i| = 1$:

$$H_{i_1} = \frac{\partial}{\partial \xi_k} \left(A_{kj}(\xi) \frac{\partial N_{i_1}(\xi)}{\partial \xi_j} + A_{ki_1}(\xi) \right), \quad S_{\emptyset} = L_{\xi\xi} Y_{\emptyset}, \quad L_{\xi\xi} Y_{\emptyset} = G_{\emptyset}$$

and at $|i| \geq 2$:

$$H_i(\xi) = L_{\xi\xi} N_i + T_i(\xi), \tag{1.5.19}$$

$$T_i(\xi) = \sum_{k=1}^s \frac{\partial}{\partial \xi_k} (A_{ki_1}(\xi) N_{i_2 \dots i_l}(\xi)) + \sum_{j=1}^s A_{i_1 j}(\xi) \frac{\partial N_{i_2 \dots i_l}(\xi)}{\partial \xi_j} + A_{i_1 i_2}(\xi) N_{i_3 \dots i_l}(\xi), \quad (1.5.20)$$

$$S_{i-1}(\xi) = L_{\xi\xi} Y_{i-1} + W_{i-1}(\xi), \quad (1.5.21)$$

$$W_{i-1}(\xi) = \sum_{k=1}^s \frac{\partial}{\partial \xi_k} (A_{ki_1}(\xi) Y_{i_2 \dots i_{l-1}}(\xi)) + \sum_{j=1}^s A_{i_1 j}(\xi) \frac{\partial Y_{i_2 \dots i_{l-1}}(\xi)}{\partial \xi_j} + A_{i_1 i_2}(\xi) Y_{i_3 \dots i_{l-1}}(\xi) \quad (1.5.22)$$

in formula (1.5.17).

Remark. We formally assume that there are zero $N_i(\xi), Y_i(\xi), S_i(\xi), G_i(\xi)$ with negative multi-index length $|i|$ in formulas (1.5.17) – (1.5.22).

Since $P\mathbf{u}$ should be equal to $\mathbf{f}_0(x) + \nabla \left(\alpha \left(\frac{x}{\varepsilon} \right) \mathbf{T} \left(x, \frac{x}{\varepsilon} \right) \right)$ rewritten in (1.5.13), we suppose that

$$H_i(\xi) = h_i, \quad S_{i-1}(\xi) - G_{i-1}(\xi) = s_{i-1},$$

where h_i and s_i are constants.

We obtain the following recurrent chain of problems of the form

$$L_{\xi\xi} N_i = -T_i(\xi) + h_i, \quad N_{\emptyset} = 1 \quad (1.5.23)$$

to determine N_i and of the form

$$L_{\xi\xi} Y_{i-1} = -W_{i-1}(\xi) + G_{i-1}(\xi) + s_{i-1}, \quad L_{\xi\xi} Y_{\emptyset} = G_{\emptyset} \quad (1.5.24)$$

to determine Y_i . N_i and Y_i are 1-periodic functions with respect to ξ . The constant matrices h_i and s_i are chosen from the solvability conditions for problems (1.5.23), (1.5.24):

$$\begin{aligned} h_i &= \langle T_i(\xi) \rangle = \left\langle \sum_{j=1}^s A_{i_1 j}(\xi) \frac{\partial N_{i_2 \dots i_l}(\xi)}{\partial \xi_j} + A_{i_1 i_2}(\xi) N_{i_3 \dots i_l}(\xi) \right\rangle, \quad l \geq 2, \\ h_{\emptyset} &= 0, \quad h_{i_1} = 0, \\ s_{i-1} &= \langle W_{i-1}(\xi) - G_{i-1}(\xi) \rangle \\ &= \left\langle \sum_{j=1}^s A_{i_1 j}(\xi) \frac{\partial Y_{i_2 \dots i_{l-1}}(\xi)}{\partial \xi_j} + A_{i_1 i_2}(\xi) Y_{i_3 \dots i_{l-1}}(\xi) - G_{i-1}(\xi) \right\rangle, \quad l \geq 2, \\ s_{\emptyset} &= 0. \end{aligned} \quad (1.5.25)$$

Thus, the algorithm for constructing the functions N_i and Y_i is recurrent: they are solutions of problems (1.5.23), (1.5.24) for $l > 0$. The right-hand side in (1.5.23) contains N_j with multi-indices j whose length is smaller than $|i|$ and the right-hand side in (1.5.24) contains Y_j with multi-indices j whose length is smaller than $|i| - 1$.

Substituting series (1.5.15)₂ we obtain

$$P_{\mathbf{u}}^{(K)} = \sum_{l=0}^{K+1} \varepsilon^{l-2} \sum_{|i|=l} \left(H_i(\xi) D^i v^{(K)} + S_{i-1}(\xi) D^{i-1} T_0 \right) + R_{1\varepsilon}^{(K)}.$$

Then by reason of (1.5.25) previous relation will go over

$$\begin{aligned} P_{\mathbf{u}}^{(K)} &= \sum_{l=2}^{K+1} \varepsilon^{l-2} \sum_{|i|=l} \left(h_i D^i v^{(K)} + (s_{i-1} + \langle G_{i-1} \rangle)(\xi) D^{i-1} T_0 \right) + R_{1\varepsilon}^{(K)} = \\ &= \sum_{\substack{l=2 \\ |i|=l}}^{K+1} \sum_{j=0}^K \varepsilon^{l+j-2} h_i D^i v_j + \sum_{l=2}^{K+1} \varepsilon^{l-2} \sum_{|i|=l} (s_{i-1} + \langle G_{i-1} \rangle)(\xi) D^{i-1} T_0 + R_{1\varepsilon}^{(K)}, \end{aligned}$$

where $G_i = 0$ at $|i| > 2$.

Assuming that $r = l + j - 2$ gives to us:

$$\sum_{\substack{l=2 \\ |i|=l}}^{K+1} \sum_{j=0}^K \varepsilon^{l+j-2} h_i D^i v_j = \sum_{r=0}^K \varepsilon^r \left(\sum_{i_1, i_2=1}^s h_{i_1 i_2} \frac{\partial^2 v_r}{\partial x_{i_1} \partial x_{i_2}} + \sum_{j=0}^{r-1} \sum_{|i|=r-j+2} h_i D^i v_j \right) + R_{2\varepsilon}^{(K)},$$

where

$$R_{2\varepsilon}^{(K)} = \sum_{r=K+1}^{2K-1} \varepsilon^r \sum_{j=0}^K \sum_{|i|=\min\{r-j+2, K+1\}} h_i D^i v_j = \sum_{r=K+1}^{2K-1} \varepsilon^r \sum_{\substack{|i|+j-2=r \\ |i| \leq K+1 \\ j \leq K}} h_i D^i v_j \quad (1.5.26)$$

because differentiation is possible while $|i| \leq K + 1$ and the functions v_j exist prior to $j = K$.

$$R_{\varepsilon}^{(K)} = R_{1\varepsilon}^{(K)} + R_{2\varepsilon}^{(K)}. \quad (1.5.27)$$

To determine v_j we have

$$\begin{aligned} \sum_{l=2}^{K+1} \varepsilon^{l-2} \sum_{|i|=l} \left(h_i D^i v^{(K)} + s_{i-1} D^{i-1} T_0 \right) &= f_0(x). \\ \sum_{i_1, i_2=1}^s h_{i_1 i_2} \frac{\partial^2 v^{(K)}}{\partial x_{i_1} \partial x_{i_2}} + s_{i_1} \frac{\partial T_0}{\partial x_{i_1}} & \\ + \sum_{l=3}^{K+1} \varepsilon^{l-2} \sum_{|i|=l} \left(h_i D^i v^{(K)} + s_{i-1} D^{i-1} T_0 \right) - f_0(x) &= 0. \end{aligned} \quad (1.5.28)$$

Problem (1.5.28) can be regarded as the homogenized equation with respect to s-dimensional vector v . Substituting series (1.5.15)₂ into (1.5.28), we obtain a recurrent chain of equations for the components v_j^k of the vectors v_j in the form

$$\sum_{i_1, i_2=1}^s h_{i_1 i_2} \frac{\partial^2 v_j}{\partial x_{i_1} \partial x_{i_2}} = g_j(x), \quad (1.5.29)$$

where $g_0 = f_0(x) - s_{i_1} \frac{\partial T_0}{\partial x_{i_1}}$, the functions g_j depend on v_{j_1} , $j_1 < j$, and on the derivatives of these functions. Thus the f.a.s. of problem (1.5.1), (1.5.2), and (1.5.15) is constructed.

1.5.4 Justification of the asymptotic expansion

After substituting $u^{(K)}$ in the left-hand side of equation (1.5.1) and repeating transformations as in the construction section we obtain $L_\varepsilon \mathbf{u}^{(K)} = f_0(x) + R_\varepsilon^{(K)}$, where $|R_\varepsilon^{(K)}| \leq c_1 \varepsilon^K$, c_1 is positive constant independent on ε . So, the difference $\mathbf{u}^{(K)} - \mathbf{u}$ is a solution to equation $L_\varepsilon(\mathbf{u}^{(K)} - \mathbf{u}) = R_\varepsilon^{(K)}$. A priori estimate (1.5.9) for this solution gives

$$\|\mathbf{u}^{(K)} - \mathbf{u}\|_{H^1} \leq C \|R_\varepsilon^{(K)}\|_{L^2} = \mathcal{O}(\varepsilon^{(K)}).$$

1.6 Conclusions

Concerning the technical physical aspect we can conclude that calculation by the described model gives residual stresses that could form after cooling of the treatment area to its original state in case of the absence of inelastic deformation

and fracturing during the cooling stage.

Vertical plate grown with the help of the SLM method on a hard substrate, is exposed to uniaxial tension and the horizontal plate is exposed to the isotropic biaxial one.

Maximum longitudinal tensile residual stresses in the individual beads are approximately twice as large as the maximum transverse one within the elastic deformation of materials during cooling after SLM.

Residual stresses in the SLM do not depend on the temperature gradient and the cooling rate under the condition of elastic deformation of the materials during cooling.

The results of the presented calculations are used to estimate the thermomechanical stability of materials in the SLM.

Concerning the mathematical aspect we can conclude that there exists a unique solution of the system of linear equations with residual stresses in the right-hand side.

The solution is constructed as a asymptotic series. Its coefficients are determined owing to the homogenization process. The difference between the asymptotic approach and the solution is small.

Chapter 2

Variational analysis of a viscous fluid-thin plate interaction problem

2.1 Introduction. Formulation of the problem

The viscous fluid - thin plate interaction problem arises in numerous applications: the blood flow near the vessel wall, the fluid motion in the pipelines, the hydrodynamic resistance to the boat, etc. In the present paper we consider a viscous fluid-3D thin rigid stratified plate interaction problem. The small parameter ε stands for the ratio of the thicknesses of the plate and of the fluid layer. In the same time the Young modulus of the plate is supposed to be great having the order of ε^{-3} , while the viscosity of the fluid, as well as the densities of the fluid and solid are supposed to be finite (i.e. of order of 1). The right hand side functions are supposed 1-periodic with respect to the tangential variables of the plate. At the plate fluid interface the velocity and the normal stress are continuous. This problem is a three dimensional generalization of the two-dimensional setting considered in [1, 2]. However the density of the plate was supposed to be much greater than the density of the fluid which is less natural for the applications. Moreover, the conclusions made on the two-dimensional modeling may be very different of the three-dimensional one, which is more realistic. That is why in the present paper the three-dimensional fluid-structure interaction is considered. Previously the problems of the fluid-structures interaction were considered in papers [3, 4, 18, 19, 25, 59]. In [3, 4, 18, 59] the deformable structure description was simplified by neglecting the thickness of the wall. In [15], the authors study the steady-state fluid-structure interaction between a three-dimensional,

axi-symmetric elastic tube filled with an incompressible viscous fluid, when the thickness of the tube wall is of the same order of magnitude as the tube radius. The elastic moduli of the wall were supposed to be of the same order that the fluid viscosity.

In the present paper the fluid flow is modeled by the 3D Stokes equations while the plate is described by the linear 3D elasticity equations. At the interface the velocity continuity and the normal stress continuity are imposed. Although the fluid and the solid phases are described in different variables (Eulerian and Lagrangian, respectively), it is supposed that the displacements and strains are small enough so that the values of the velocity and of the pressure are close in both variables.

The fluid occupies the horizontal layer $L^- = \mathbb{R}^2 \times (-1, 0)$ while the plate corresponds to the thin layer $L_\varepsilon^+ = \mathbb{R}^2 \times (0, \varepsilon)$, where ε is a small positive parameter. The applied mass forces are supposed to be 1-periodic with respect to the “horizontal” variables x_1 and x_2 . Put $\bar{x} = (x_1, x_2)$, $x = (x_1, x_2, x_3)$ and denote the

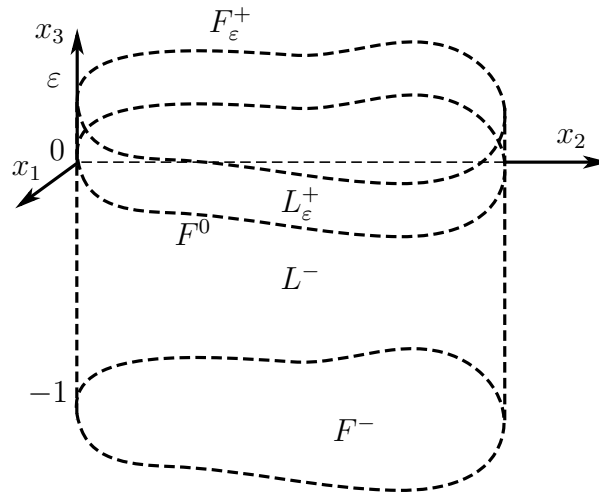

Fig. 9. 3D layer

interface between the liquid and solid phase $F^0 = \{\bar{x} \in \mathbb{R}^2, x_3 = 0\}$, the bottom plane of the liquid phase $F^- = \{\bar{x} \in \mathbb{R}^2, x_3 = -1\}$, and the upper plate’s surface $F_\varepsilon^+ = \{\bar{x} \in \mathbb{R}^2, x_3 = \varepsilon\}$. Denote D the square $(0, 1)^2$. Then the fluid-plate interaction problem can be described by the following boundary value problem:

$$\left\{ \begin{array}{l}
\text{Find triplet } (\mathbf{u}_\varepsilon, \mathbf{v}_\varepsilon, p_\varepsilon) \text{ such that} \\
\rho_+ \left(\frac{x_3}{\varepsilon} \right) \frac{\partial^2 \mathbf{u}_\varepsilon}{\partial t^2} - \varepsilon^{-3} \sum_{i,j=1}^3 \frac{\partial}{\partial x_i} \left(A_{ij} \left(\frac{x_3}{\varepsilon} \right) \frac{\partial \mathbf{u}_\varepsilon}{\partial x_j} \right) = \varepsilon^{-1} \mathbf{g}(\bar{x}, t) \text{ in } L_\varepsilon^+ \times (0, T), \\
\rho_- \frac{\partial \mathbf{v}_\varepsilon}{\partial t} - 2\tilde{\nu} \operatorname{div} (D(\mathbf{v}_\varepsilon)) + \nabla p_\varepsilon = \mathbf{f}(x, t) \quad \text{in } L^- \times (0, T), \\
\operatorname{div} \mathbf{v}_\varepsilon = 0 \quad \text{in } L^- \times (0, T), \\
\sum_{j=1}^3 A_{3j}(1) \frac{\partial \mathbf{u}_\varepsilon}{\partial x_j} = \mathbf{0} \text{ on } F_\varepsilon^+ \times (0, T), \\
\mathbf{v}_\varepsilon = \mathbf{0} \text{ on } F^- \times (0, T), \\
\left\{ \begin{array}{l}
\mathbf{v}_\varepsilon = \frac{\partial \mathbf{u}_\varepsilon}{\partial t}, \\
-p_\varepsilon \mathbf{e}_3 + 2\tilde{\nu} D(\mathbf{v}_\varepsilon) \mathbf{e}_3 = \varepsilon^{-3} \sum_{j=1}^3 A_{3j}(0) \frac{\partial \mathbf{u}_\varepsilon}{\partial x_j} \quad \text{on } F^0 \times (0, T),
\end{array} \right. \\
\mathbf{u}_\varepsilon, \mathbf{v}_\varepsilon, p_\varepsilon \quad D\text{-periodic}, \\
\mathbf{u}_\varepsilon(x, 0) = \frac{\partial \mathbf{u}_\varepsilon}{\partial t}(x, 0) = \mathbf{0} \text{ in } L_\varepsilon^+, \\
\mathbf{v}_\varepsilon(x, 0) = \mathbf{0} \text{ in } L^-,
\end{array} \right. \tag{2.1.1}$$

with a positive given constant T .

The characteristics of the elastic medium are described by the variable density $\rho_+(\xi_3)$, by 3×3 matrix-valued functions $\varepsilon^{-3} A_{ij}(\xi_3)$, $i, j \in \{1, 2, 3\}$ of elastic moduli of the plate material, by the Young's modulus $\varepsilon^{-3} E(\xi_3)$ and by the Poisson's coefficient $\nu(\xi_3)$, with

$$\xi_3 = \frac{x_3}{\varepsilon}. \tag{2.1.2}$$

The plate is supposed to be heterogeneous, stratified, and so these coefficients depend on the variable x_3 . We study the case corresponding to ρ_+ and E of order one (the elastic moduli are of order ε^{-3}). The coefficients ρ_+ and A_{ij} are supposed to be piecewise smooth functions on $[0, 1]$ i.e. there exist $p \in \mathbb{N}$, $p \geq 2$ and $p + 1$ real numbers $\zeta_0, \zeta_1, \dots, \zeta_p$, with $0 = \zeta_0 < \zeta_1 < \dots < \zeta_p = 1$ such that $\rho_+, a_{ij}^{kl} \in C^1([\zeta_a, \zeta_{a+1}])$, $a = 0, 1, \dots, p-1$, $i, j, k, l \in \{1, 2, 3\}$; moreover, there exist two positive constants $\rho_{min}^+, \rho_{max}^+$ independent of ε such that

$$\rho_{min}^+ \leq \rho_+(\xi_3) \leq \rho_{max}^+, \quad \forall \xi_3 \in [0, 1]. \tag{2.1.3}$$

The matrices $A_{ij} = (a_{ij}^{kl})_{1 \leq k, l \leq 3}$ with the elements a_{ij}^{kl} defined via two piecewise-smooth functions E and ν by the following formula $a_{ij}^{kl} = \frac{E}{2(1+\nu)} \left(\frac{2\nu}{1-2\nu} \delta_{ik} \delta_{jl} + \delta_{ij} \delta_{kl} + \delta_{il} \delta_{jk} \right)$ satisfying the bounds $-1 < \nu < 1/2$, $E > 0$. Hence, they satisfy the properties:

- (i) $a_{ij}^{kl}(\xi_3) = a_{kj}^{il}(\xi_3) = a_{ji}^{lk}(\xi_3)$, $\forall i, j, k, l \in \{1, 2, 3\}$, $\forall \xi_3 \in [0, 1]$,
- (ii) $\exists \kappa > 0$ independent of ε such that $\sum_{i,j,k,l=1}^3 a_{ij}^{kl}(\xi_3) \eta_j^l \eta_i^k \geq \kappa \sum_{j,l=1}^3 (\eta_j^l)^2$, $\forall \xi_3 \in [0, 1]$, $\forall \eta = (\eta_j^l)_{1 \leq j, l \leq 3}$, with $\eta_j^l = \eta_l^j$.

The matrices A_{ij} have the following expressions:

$$\left\{ \begin{array}{l} A_{11}(\xi_3) = \begin{pmatrix} \frac{E(\xi_3)(1-\nu(\xi_3))}{(1+\nu(\xi_3))(1-2\nu(\xi_3))} & 0 & 0 \\ 0 & \frac{E(\xi_3)}{2(1+\nu(\xi_3))} & 0 \\ 0 & 0 & \frac{E(\xi_3)}{2(1+\nu(\xi_3))} \end{pmatrix}, A_{22}(\xi_3) = \begin{pmatrix} \frac{E(\xi_3)}{2(1+\nu(\xi_3))} & 0 & 0 \\ 0 & \frac{E(\xi_3)(1-\nu(\xi_3))}{(1+\nu(\xi_3))(1-2\nu(\xi_3))} & 0 \\ 0 & 0 & \frac{E(\xi_3)}{2(1+\nu(\xi_3))} \end{pmatrix}, \\ A_{33}(\xi_3) = \begin{pmatrix} \frac{E(\xi_3)}{2(1+\nu(\xi_3))} & 0 & 0 \\ 0 & \frac{E(\xi_3)}{2(1+\nu(\xi_3))} & 0 \\ 0 & 0 & \frac{E(\xi_3)(1-\nu(\xi_3))}{(1+\nu(\xi_3))(1-2\nu(\xi_3))} \end{pmatrix}, \\ A_{12}(\xi_3) = \begin{pmatrix} 0 & \frac{E(\xi_3)\nu(\xi_3)}{(1+\nu(\xi_3))(1-2\nu(\xi_3))} & 0 \\ \frac{E(\xi_3)}{2(1+\nu(\xi_3))} & 0 & 0 \\ 0 & 0 & 0 \end{pmatrix}, A_{13}(\xi_3) = \begin{pmatrix} 0 & 0 & \frac{E(\xi_3)\nu(\xi_3)}{(1+\nu(\xi_3))(1-2\nu(\xi_3))} \\ 0 & 0 & 0 \\ \frac{E(\xi_3)}{2(1+\nu(\xi_3))} & 0 & 0 \end{pmatrix}, \\ A_{21}(\xi_3) = \begin{pmatrix} 0 & \frac{E(\xi_3)}{2(1+\nu(\xi_3))} & 0 \\ \frac{E(\xi_3)\nu(\xi_3)}{(1+\nu(\xi_3))(1-2\nu(\xi_3))} & 0 & 0 \\ 0 & 0 & 0 \end{pmatrix}, A_{23}(\xi_3) = \begin{pmatrix} 0 & 0 & 0 \\ 0 & 0 & \frac{E(\xi_3)\nu(\xi_3)}{(1+\nu(\xi_3))(1-2\nu(\xi_3))} \\ 0 & \frac{E(\xi_3)}{2(1+\nu(\xi_3))} & 0 \end{pmatrix}, \\ A_{31}(\xi_3) = \begin{pmatrix} 0 & 0 & \frac{E(\xi_3)}{2(1+\nu(\xi_3))} \\ 0 & 0 & 0 \\ \frac{E(\xi_3)\nu(\xi_3)}{(1+\nu(\xi_3))(1-2\nu(\xi_3))} & 0 & 0 \end{pmatrix}, A_{32}(\xi_3) = \begin{pmatrix} 0 & 0 & 0 \\ 0 & 0 & \frac{E(\xi_3)}{2(1+\nu(\xi_3))} \\ 0 & \frac{E(\xi_3)\nu(\xi_3)}{(1+\nu(\xi_3))(1-2\nu(\xi_3))} & 0 \end{pmatrix}. \end{array} \right. \quad (2.1.4)$$

The characteristics of the viscous fluid, independent of ε , are the positive constants ρ_- and $\tilde{\nu}$ representing its density and its viscosity, respectively. In addition to the data ρ_+ , A_{ij} , E , ν (for the elastic medium) and ρ_- , $\tilde{\nu}$ (for the viscous fluid), we also know right hand side functions \mathbf{g} and \mathbf{f} , the scaled mass forces, which

act on the elastic medium and on the fluid, respectively; they are supposed to be 1-periodic in x_1 and x_2 .

The unknown functions $\mathbf{u}_\varepsilon, \mathbf{v}_\varepsilon, p_\varepsilon$ are the plate displacement, the fluid velocity and the pressure, respectively.

In the Stokes equations the standard notation is used for the symmetrized gradient:

$$D(\mathbf{v}) = \frac{1}{2}(\nabla \mathbf{v} + (\nabla \mathbf{v})^T), \quad (2.1.5)$$

and represents the velocity strain tensor. We will use as well the following notation for the strain tensor in the plate:

$$\mathcal{E}(\mathbf{u}) = \frac{1}{2}(\nabla \mathbf{u} + (\nabla \mathbf{u})^T). \quad (2.1.6)$$

As usual, at the layer interfaces within the elastic plate the continuity conditions are satisfied for the displacement \mathbf{u}_ε as well as for the normal stress $\sum_{j=1}^3 A_{3j} \frac{\partial \mathbf{u}_\varepsilon}{\partial x_j}$ (see [55]).

We emphasize that the plate's material Young modulus is great; it is of the order ε^{-3} and depends on the "vertical" fast variable $\xi_3 = \frac{x_3}{\varepsilon}$: it is equal to $\varepsilon^{-3}E(\xi_3)$, where E is a function of order one, while the Poisson's ratio $\nu(\xi_3)$ is of order of one. This value of the Young's modulus is critical with respect to the small parameter ε that is the ratio of thicknesses of the plate and of the fluid layer (the fluid layer thickness is of the same order as the period of the right hand sides). For this value of the Young's modulus there is a coupling in the limit problem between the Stokes equations and the limit plate equation. This coupling generates a non-standard boundary condition for the Stokes equations. In other cases the Stokes equations and the limit plate equation may be decoupled.

This boundary value problem for the coupled elasticity equations and the Stokes equations describing the fluid covered with a stratified plate may be used for the modeling of the blood flow - the vessel wall interaction in hemodynamics, as well as for the flow-wall interaction in the pipelines. In order to provide mathematical analysis of this problem, let us state the variational formulation and define a weak solution. To this end let us reduce the number of the unknown functions. Extend formally the velocity \mathbf{v}_ε to the layer L_ε^+ : $\mathbf{u}_\varepsilon(x, t) = \int_0^t \mathbf{v}_\varepsilon(x, s) ds$ and

exclude the pressure p_ε by introducing the divergence free functional space for the test functions in the fluid part of the domain. This step is quite standard for the Stokes and the Navier-Stokes equations [24], [60]: normally the variational formulation starts without the pressure in the solenoidal functional space and then, if needed, the pressure is defined according to the De Rham theorem, so that both formulations are equivalent. Let us introduce the necessary functional spaces. In what follows we call function f defined in $\mathbb{R}^2 \times (a, b)$ (and so depending on x_1, x_2 and eventually $x_3 \in (a, b)$) D -periodic iff for any integer i_1, i_2 , and for any real x_1, x_2 (and eventually for any real $x_3 \in (a, b)$) the relation $f(x_1 + i_1, x_2 + i_2, x_3) = f(x_1, x_2, x_3)$ holds.

Define the periodicity domains by

$$D^- = D \times (-1, 0), \quad D_\varepsilon^+ = D \times (0, \varepsilon), \quad D_\varepsilon = D \times (-1, \varepsilon), \quad (2.1.7)$$

with D^- the fluid part and D_ε^+ the elastic part.

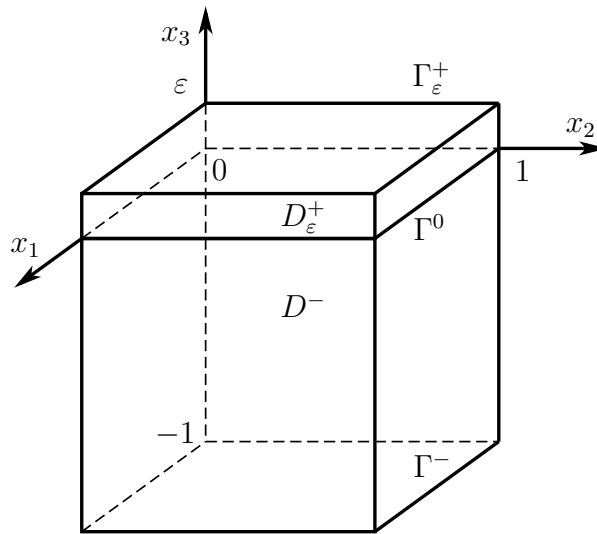

Fig. 10. Periodicity domain

Introduce the “horizontal” boundaries and interface in the periodic cell:

$$\begin{cases} \Gamma^- = \{(\bar{x}, -1)/\bar{x} \in D\}, \\ \Gamma^0 = \{(\bar{x}, 0)/\bar{x} \in D\}, \\ \Gamma_\varepsilon^+ = \{(\bar{x}, \varepsilon)/\bar{x} \in D\}. \end{cases} \quad (2.1.8)$$

Define

$$C_{\#}^{\infty}(D) = \left\{ f \in C^{\infty}(\mathbb{R}^2) \mid f - D\text{-periodic} \right\},$$

$$L_{\#}^2(D) = \left\{ f \in L_{loc}^2(\mathbb{R}^2) \mid f - D\text{-periodic} \right\}, \quad \|f\|_{L_{\#}^2(D)} = \|f\|_{L^2(D)},$$

$$L_{\#}^2(D^-) = \left\{ f \in L_{loc}^2(\mathbb{R}^2 \times (-1, 0)) \mid f - D\text{-periodic} \right\}, \quad \|f\|_{L_{\#}^2(D^-)} = \|f\|_{L^2(D^-)},$$

$$L_{\#}^2(D_{\varepsilon}^+) = \left\{ f \in L_{loc}^2(\mathbb{R}^2 \times (0, \varepsilon)) \mid f - D\text{-periodic} \right\}, \quad \|f\|_{L_{\#}^2(D_{\varepsilon}^+)} = \|f\|_{L^2(D_{\varepsilon}^+)},$$

$$L_{\#}^2(D_{\varepsilon}) = \left\{ f \in L_{loc}^2(\mathbb{R}^2 \times (-1, \varepsilon)) \mid f - D\text{-periodic} \right\}, \quad \|f\|_{L_{\#}^2(D_{\varepsilon})} = \|f\|_{L^2(D_{\varepsilon})},$$

$$H_{\#}^1(D^-) = \left\{ f \in H_{loc}^1(\mathbb{R}^2 \times (-1, 0)) \mid f - D\text{-periodic} \right\}, \quad \|f\|_{H_{\#}^1(D^-)} = \|f\|_{H^1(D^-)},$$

$$H_{\#}^1(D_{\varepsilon}^+) = \left\{ f \in H_{loc}^1(\mathbb{R}^2 \times (0, \varepsilon)) \mid f - D\text{-periodic} \right\}, \quad \|f\|_{H_{\#}^1(D_{\varepsilon}^+)} = \|f\|_{H^1(D_{\varepsilon}^+)},$$

$$H_{\#}^1(D_{\varepsilon}) = \left\{ f \in H_{loc}^1(\mathbb{R}^2 \times (-1, \varepsilon)) \mid f - D\text{-periodic} \right\}, \quad \|f\|_{H_{\#}^1(D_{\varepsilon})} = \|f\|_{H^1(D_{\varepsilon})}.$$

The corresponding inner products are introduced in these Hilbert spaces in a standard way.

Let us define

$$V = \left\{ \boldsymbol{\varphi} \in (H_{\#}^1(D_{\varepsilon}))^3 \mid \operatorname{div} \boldsymbol{\varphi} = 0 \text{ in } D^-, \boldsymbol{\varphi} = \mathbf{0} \text{ on } \Gamma^- \right\} \quad (2.1.9)$$

and

$$V^+ = (H_{\#}^1(D_{\varepsilon}^+))^3, \quad (2.1.10)$$

Note that since the space V introduced in (2.1.9) is a separable Hilbert space, we can select a countable orthogonal in $L_{\#}^2(D_{\varepsilon})$ basis $\{\boldsymbol{\varphi}_j\}_{j=1}^{\infty}$. Assume that the right hand side functions have the following regularity

$$\mathbf{g} \in H^1(0, T; (L_{\#}^2(D_{\varepsilon}^+))^3), \quad \mathbf{f} \in H^1(0, T; (L_{\#}^2(D^-))^3), \quad (2.1.11)$$

while ρ_+ , a_{ij}^{kl} are piecewise-smooth as it was formulated above.

We also put

$$H_v = \left\{ \mathbf{v} \in L^2(0, T; V) \mid \mathbf{v}' \in L^2(0, T; V'), \int_0^t \mathbf{v} dt \in L^2(0, T; V^+) \right\}.$$

Define a weak solution to problem (2.1.1) as a function \mathbf{v}_ε satisfying the following integral identity:

$$\left\{ \begin{array}{l} \text{Find } \mathbf{v}_\varepsilon \in H_v \\ \frac{d}{dt} \int_{D_\varepsilon} (\rho_+ \chi(D_\varepsilon^+) + \rho_- \chi(D^-)) \mathbf{v}_\varepsilon \cdot \boldsymbol{\varphi} + \varepsilon^{-3} \int_{D_\varepsilon^+} \sum_{i,j=1}^3 A_{ij} \frac{\partial}{\partial x_j} \left(\int_0^t \mathbf{v}_\varepsilon dt \right) \cdot \frac{\partial \boldsymbol{\varphi}}{\partial x_i} \\ + 2\tilde{\nu} \int_{D^-} D(\mathbf{v}_\varepsilon) : D(\boldsymbol{\varphi}) = \int_{D_\varepsilon} (\varepsilon^{-1} \chi(D_\varepsilon^+) \mathbf{g} + \chi(D^-) \mathbf{f}) \cdot \boldsymbol{\varphi} \quad \forall \boldsymbol{\varphi} \in V \text{ a.e. in } (0, T), \\ \mathbf{v}_\varepsilon(0) = \mathbf{0} \text{ in } D_\varepsilon, \end{array} \right. \quad (2.1.12)$$

Here $\chi(A)$ is the characteristic function of the set A . Remind that so defined weak solution corresponds to the velocity function only, while the displacement in the solid phase and the pressure are absent. In the next section we study this variational formulation from the point of view of the existence and uniqueness of its solution. Then, using the mentioned regularity of the data, we prove the corresponding regularity of function \mathbf{v}_ε which gives the regularity of the displacement and that of the pressure, previously introduced as a distribution. An important difference of this problem with respect to the standard Stokes or the Navier-Stokes equations is that the pressure is defined here uniquely. This gives us a possibility to prove that the triplet velocity - displacement - pressure satisfies the relations (2.1.1) pointwisely.

Remark. The function \mathbf{u}_ε is given by $\mathbf{u}_\varepsilon(x, t) = \int_0^t \mathbf{v}_\varepsilon(x, s) ds$ for $(x, t) \in D_\varepsilon^+ \times (0, T)$, where \mathbf{v}_ε represents a continuous extension of the fluid velocity in $(\bar{D}_\varepsilon \setminus \bar{D}^-) \times (0, T)$, due to (2.1.1)₆, and it was denoted in (2.1.12) also by \mathbf{v}_ε . So, the displacement is formally eliminated for performing the variational analysis of

problem (2.1.1), it can be rewritten in the form:

$$\left\{ \begin{array}{l} \rho_+ \frac{\partial \mathbf{v}_\varepsilon}{\partial t} - \varepsilon^{-3} \sum_{i,j=1}^3 \frac{\partial}{\partial x_i} \left(A_{ij} \frac{\partial}{\partial x_j} \left(\int_0^t \mathbf{v}_\varepsilon(s) ds \right) \right) = \varepsilon^{-1} \mathbf{g} \text{ in } D_\varepsilon^+ \times (0, T), \\ \rho_- \frac{\partial \mathbf{v}_\varepsilon}{\partial t} - 2\tilde{\nu} \operatorname{div}(D(\mathbf{v}_\varepsilon)) + \nabla p_\varepsilon = \mathbf{f} \text{ in } D^- \times (0, T), \\ \operatorname{div} \mathbf{v}_\varepsilon = 0 \text{ in } D^- \times (0, T), \\ \sum_{j=1}^3 A_{3j} \frac{\partial}{\partial x_j} \left(\int_0^t \mathbf{v}_\varepsilon(s) ds \right) = \mathbf{0} \text{ on } \Gamma_\varepsilon^+ \times (0, T), \\ \mathbf{v}_\varepsilon = \mathbf{0} \text{ on } \Gamma^- \times (0, T), \\ -p_\varepsilon \mathbf{e}_3 + 2\tilde{\nu} D(\mathbf{v}_\varepsilon) \mathbf{e}_3 = \varepsilon^{-3} \sum_{j=1}^3 A_{3j} \frac{\partial}{\partial x_j} \left(\int_0^t \mathbf{v}_\varepsilon(s) ds \right) \text{ on } \Gamma^0 \times (0, T), \\ \mathbf{v}_\varepsilon, p_\varepsilon \quad D\text{-periodic}, \\ \mathbf{v}_\varepsilon(0) = \mathbf{0} \text{ in } D_\varepsilon. \end{array} \right. \quad (2.1.13)$$

After multiplication of (2.1.13)_{1,2} by $\varphi_{/D_\varepsilon^+}$, $\varphi_{/D^-}$, respectively and integration by parts we obtain, by means of the other equations and conditions of (2.1.13), the problem (2.1.12) that we will study from a variational viewpoint.

2.2 Existence and uniqueness of a solution

2.2.1 Main problem

Consider the variational formulation (2.1.12). The following theorem holds.

Theorem 2.1. *Let \mathbf{g} and \mathbf{f} have the regularity given by (2.1.11). Then there exists a unique solution $\mathbf{v}_\varepsilon \in H_v$ of problem (2.1.12).*

Proof. The proof of the existence and uniqueness of solution to problem (2.1.12) is based on the Galerkin's method.

System of Galerkin approximations is

$$\left\{ \begin{array}{l} \int_{D_\varepsilon} (\rho_+ \chi(D_\varepsilon^+) + \rho_- \chi(D^-)) \frac{\partial \mathbf{v}_n}{\partial t} \cdot \boldsymbol{\varphi} \\ + \varepsilon^{-3} \int_{D_\varepsilon^+} \sum_{i,j=1}^3 A_{ij} \frac{\partial}{\partial x_j} \left(\int_0^t \mathbf{v}_n(s) ds \right) \frac{\partial \boldsymbol{\varphi}}{\partial x_i} + 2\tilde{\nu} \int_{D^-} D(\mathbf{v}_n) : D(\boldsymbol{\varphi}) \\ = \int_{D_\varepsilon} (\varepsilon^{-1} \chi(D_\varepsilon^+) \mathbf{g} + \chi(D^-) \mathbf{f}) \cdot \boldsymbol{\varphi} \quad \forall \boldsymbol{\varphi} \in V_n \text{ a.e. in } (0, T), \\ \mathbf{v}_n(0) = \mathbf{0} \text{ in } D_\varepsilon, \end{array} \right. \quad (2.2.1)$$

where $V_n = \text{span}\{\boldsymbol{\varphi}_1, \boldsymbol{\varphi}_2, \dots, \boldsymbol{\varphi}_n\}$.

The solution is sought in the form

$$\mathbf{v}_n = \sum_{k=1}^n a_k(t) \boldsymbol{\varphi}_k(x), \quad \text{in } D_\varepsilon \times (0, T), \quad (2.2.2)$$

with the functions a_k determined from the system of integro-differential equations:

$$\left\{ \begin{array}{l} \sum_{p=1}^n \int_{D_\varepsilon} (\rho_+ \chi(D_\varepsilon^+) + \rho_- \chi(D^-)) \boldsymbol{\varphi}_p \cdot \boldsymbol{\varphi}_k a_k'(t) \\ + \sum_{p=1}^n \varepsilon^{-3} \left(\int_{D_\varepsilon^+} \sum_{i,j=1}^3 A_{ij} \frac{\partial \boldsymbol{\varphi}_p}{\partial x_j} \cdot \frac{\partial \boldsymbol{\varphi}_k}{\partial x_i} \right) \int_0^t a_k(s) ds + \sum_{p=1}^n 2\tilde{\nu} \left(\int_{D^-} D(\boldsymbol{\varphi}_p) : D(\boldsymbol{\varphi}_k) \right) a_k(t) \\ = \int_{D_\varepsilon} (\varepsilon^{-1} \chi(D_\varepsilon^+) \mathbf{g} + \chi(D^-) \mathbf{f}) \cdot \boldsymbol{\varphi}_k \quad \text{a.e. in } (0, T), \\ a_k(0) = 0 \quad k = 1, \dots, n. \end{array} \right. \quad (2.2.3)$$

We denote

$$c_k(t) = \int_0^t a_k(s) ds. \quad (2.2.4)$$

So, as $a_k = c_k'$, system (2.2.3) becomes a system of linear differential equations of

order 2 that can be used for determination of functions $c_k(t)$, $k = 1, \dots, n$:

$$\left\{ \begin{array}{l} \sum_{p=1}^n \int_{D_\varepsilon} (\rho_+ \chi(D_\varepsilon^+) + \rho_- \chi(D^-)) \varphi_p \cdot \varphi_k c_k''(t) \\ + \sum_{p=1}^n \varepsilon^{-3} \left(\int_{D_\varepsilon^+} \sum_{i,j=1}^3 A_{ij} \frac{\partial \varphi_p}{\partial x_j} \cdot \frac{\partial \varphi_k}{\partial x_i} \right) c_k(t) + \sum_{p=1}^n 2\tilde{\nu} \left(\int_{D^-} D(\varphi_p) : D(\varphi_k) \right) c_k'(t) \\ = \int_{D_\varepsilon} (\varepsilon^{-1} \chi(D_\varepsilon^+) \mathbf{g} + \chi(D^-) \mathbf{f}) \cdot \varphi_k \quad \text{a.e. in } (0, T), \\ c_k(0) = c_k'(0) = 0 \quad k = 1, \dots, n. \end{array} \right. \quad (2.2.5)$$

System (2.2.5) has a unique solution, since the matrix

$$\mathcal{M} = \left(\int_{D_\varepsilon} (\chi(D_\varepsilon^+) \rho_+ + \chi(D^-) \rho_-) \varphi_p \cdot \varphi_k \right)_{1 \leq p, k \leq n} \quad (2.2.6)$$

is non-degenerate. Denoting

$$\rho_\pm = \rho_+ \chi(D_\varepsilon^+) + \rho_- \chi(D^-), \quad (2.2.7)$$

we obtain that

$$\begin{aligned} \mathcal{M} \xi \cdot \xi &= \left(\sum_{p=1}^n \int_{D_\varepsilon} \rho_\pm \xi_p \varphi_p \varphi_k \right)_{1 \leq k \leq n} \cdot \xi \\ &= \sum_{p,k=1}^n \int_{D_\varepsilon} \rho_\pm \xi_p \varphi_p \xi_k \varphi_k = \int_{D_\varepsilon} \rho_\pm \left(\sum_{j=1}^n \xi_j \varphi_j \right)^2 \geq 0. \end{aligned}$$

Thus $\mathcal{M} \xi \cdot \xi = 0$ if and only if $\xi_1 = \xi_2 = \dots = \xi_n = \mathbf{0}$ or $\xi = \mathbf{0}$ (because the system $\{\varphi_k\}$ is a linear independent system).

Next, for passing to the limit in (2.2.1)₁ as $n \rightarrow \infty$ (and to get weak formulation

of the problem), we will prove the following estimates:

$$\begin{aligned} \|\mathbf{v}_n\|_{L^\infty(0,T;(L^2(D^-))^3)} &\leq C, \quad \left\| \frac{\partial \mathbf{v}_n}{\partial t} \right\|_{L^\infty(0,T;(L^2(D_\varepsilon))^3)} \leq C, \\ \left\| \int_{D_\varepsilon^+} \sum_{i,j=1}^3 A_{ij} \frac{\partial}{\partial x_j} \left(\int_0^t \mathbf{v}_\varepsilon dt \right) \frac{\partial}{\partial x_i} \left(\int_0^t \mathbf{v}_\varepsilon dt \right) \right\|_{L^\infty(0,T)} &\leq C, \\ \|D(\mathbf{v}_n)\|_{L^2(0,T;(L^2(D^-))^{3 \times 3})} &\leq C. \end{aligned} \quad (2.2.8)$$

To this effect we take in (2.2.1)₁ $\boldsymbol{\varphi} = \boldsymbol{\varphi}_k$, multiply by $a_k(t)$, sum up from $k = 1$ to n and integrate from 0 to t :

$$\begin{aligned} \int_{D_\varepsilon} \rho_\pm \mathbf{v}_n^2 + \varepsilon^{-3} \int_{D_\varepsilon^+} \sum_{i,j=1}^3 A_{ij} \frac{\partial}{\partial x_j} \left(\int_0^t \mathbf{v}_n(s) ds \right) \frac{\partial}{\partial x_i} \left(\int_0^t \mathbf{v}_n(s) ds \right) \\ + 4\tilde{\nu} \int_0^t \int_{D^-} (D(\mathbf{v}_n))^2 = 2 \int_0^t \int_{D_\varepsilon} (\varepsilon^{-1} \chi(D_\varepsilon^+) \mathbf{g} + \chi(D^-) \mathbf{f}) \mathbf{v}_n. \end{aligned} \quad (2.2.9)$$

The function ρ_\pm defined in (2.2.7) can be evaluated owing to (2.1.3) as follows

$$\rho_\pm \geq \rho_{min}^+ \chi(D_\varepsilon^+) + \rho_- \chi(D^-) \geq c_1,$$

with $c_1 = \min \{ \rho_{min}^+, \rho_- \}$. Denoting $\mathbf{F}_\pm = \varepsilon^{-1} \chi(D_\varepsilon^+) \mathbf{g} + \chi(D^-) \mathbf{f}$, using the previous inequality and Cauchy-Schwarz-Bunyakovsky inequality we obtain from (2.2.9)

$$\begin{aligned} c_1 \int_{D_\varepsilon} \mathbf{v}_n^2 + \varepsilon^{-3} \int_{D_\varepsilon^+} \sum_{i,j=1}^3 A_{ij} \frac{\partial}{\partial x_j} \left(\int_0^t \mathbf{v}_n(s) ds \right) \frac{\partial}{\partial x_i} \left(\int_0^t \mathbf{v}_n(s) ds \right) \\ + 4\tilde{\nu} \int_0^t \int_{D^-} (D(\mathbf{v}_n))^2 \leq 2 \int_0^T \|\mathbf{F}_\pm(t)\|_{(L^2(D_\varepsilon))^3} \|\mathbf{v}_n(t)\|_{(L^2(D_\varepsilon))^3} dt. \end{aligned} \quad (2.2.10)$$

The right-hand side in (2.2.10) can be evaluated as outlined below

$$\begin{aligned} 2 \int_0^T \|\mathbf{F}_\pm(t)\|_{(L^2(D_\varepsilon))^3} \|\mathbf{v}_n(t)\|_{(L^2(D_\varepsilon))^3} dt &\leq 2 \|\mathbf{F}_\pm\|_{L^1(0,T;(L^2(D_\varepsilon))^3)} \|\mathbf{v}_n\|_{L^\infty(0,T;(L^2(D_\varepsilon))^3)} \\ &\leq \frac{c_1}{2} \|\mathbf{v}_n\|_{L^\infty(0,T;(L^2(D_\varepsilon))^3)}^2 + \frac{2}{c_1} \|\mathbf{F}_\pm\|_{L^1(0,T;(L^2(D_\varepsilon))^3)}^2. \end{aligned}$$

Finally we obtain the following estimates

$$\begin{aligned} & \frac{c_1}{2} \|\mathbf{v}_n\|_{L^\infty(0,T;(L^2(D_\varepsilon))^3)}^2 + 4\tilde{\nu} \|D(\mathbf{v}_n)\|_{L^2(0,T;(L^2(D^-))^{3 \times 3})}^2 \\ & + \varepsilon^{-3} \left\| \int_{D_\varepsilon} \sum_{i,j=1}^3 A_{ij} \frac{\partial}{\partial x_j} \left(\int_0^t \mathbf{v}_n(s) \, ds \right) \frac{\partial}{\partial x_i} \left(\int_0^t \mathbf{v}_n(s) \, ds \right) \right\|_{L^\infty(0,T)} \leq \|\mathbf{f}, \mathbf{g}\|_1, \end{aligned} \quad (2.2.11)$$

where

$$\|\mathbf{f}, \mathbf{g}\|_1 = \frac{2}{c_1} \|\mathbf{F}_\pm\|_{L^1(0,T;(L^2(D_\varepsilon))^3)}^2. \quad (2.2.12)$$

We differentiate next (2.2.1)₁ with respect to t (it is possible thanks to regularity (2.1.11) for \mathbf{g} and \mathbf{f}). In order to get an estimate for $\mathbf{v}'_n(0)$ we consider (2.2.1)₁ at the moment $t = 0$

$$\int_{D_\varepsilon} \rho_\pm \mathbf{v}'_n(0) \cdot \boldsymbol{\varphi}_k = \int_{D_\varepsilon} \mathbf{F}_\pm(0) \cdot \boldsymbol{\varphi}_k \quad k = 1, \dots, n; \quad (2.2.13)$$

we calculate then $\sum_{k=1}^n (2.2.13) \cdot a'_k(0)$, which yields

$$\int_{D_\varepsilon} \rho_\pm (\mathbf{v}'_n(0))^2 = \int_{D_\varepsilon} \mathbf{F}_\pm(0) \cdot \mathbf{v}'_n(0). \quad (2.2.14)$$

From relation (2.2.14) with the inequality $\rho_\pm \geq c_1$ it follows that

$$c_1 \|\mathbf{v}'_n(0)\|_{(L^2(D_\varepsilon))^3}^2 \leq \frac{1}{c_1} \|\mathbf{F}_\pm(0)\|_{(L^2(D_\varepsilon))^3}^2 \stackrel{def}{=} \frac{\|\mathbf{f}, \mathbf{g}\|_0}{c_1}. \quad (2.2.15)$$

We repeat the same technique as before; i.e. we compute $\sum_{k=1}^n (2.2.1)'_1 \cdot a'_k(t)$ and we integrate in time:

$$\begin{aligned} & \int_{D_\varepsilon} \rho_\pm (\mathbf{v}'_n)^2 + \varepsilon^{-3} \int_{D_\varepsilon^+} \sum_{i,j=1}^3 A_{ij} \frac{\partial \mathbf{v}_n}{\partial x_j} \frac{\partial \mathbf{v}_n}{\partial x_i} + 4\tilde{\nu} \int_0^t \int_{D^-} (D(\mathbf{v}'_n))^2 \\ & = 2 \int_0^t \int_{D_\varepsilon} \mathbf{F}'_\pm \mathbf{v}'_n + \int_{D_\varepsilon} \rho_\pm (\mathbf{v}'_n(0))^2, \end{aligned}$$

which gives the estimates:

$$\begin{aligned} \frac{c_1}{2} \|\mathbf{v}'_n\|_{L^\infty(0,T;(L^2(D_\varepsilon))^3)}^2 + \varepsilon^{-3} \left\| \int_{D_\varepsilon} \sum_{i,j=1}^3 A_{ij} \frac{\partial \mathbf{v}_n}{\partial x_j} \frac{\partial \mathbf{v}_n}{\partial x_i} \right\|_{L^\infty(0,T)} \\ + 4\tilde{\nu} \|D(\mathbf{v}'_n)\|_{L^2(0,T;(L^2(D^-))^{3 \times 3})}^2 \leq \|\mathbf{f}', \mathbf{g}'\|_1 + \frac{c_2}{c_1^2} \|\mathbf{f}, \mathbf{g}\|_0, \end{aligned} \quad (2.2.16)$$

where $c_2 = \max\{\rho_{max}^+, \rho_-\}$. So, the maximal regularity obtained for \mathbf{v}'_n from (2.2.16) is:

$$\begin{cases} \mathbf{v}'_n \in L^\infty(0,T;(L^2_\#(D_\varepsilon))^3), \\ \mathbf{v}'_n \in L^2(0,T;(H^1_\#(D^-))^3). \end{cases} \quad (2.2.17)$$

From (2.2.11), (2.2.16), the definition of the weakly-* convergence and the Banach-Alaoglu theorem [61] it follows that

$$\begin{cases} \mathbf{v}_{n_k} \rightarrow \mathbf{v}_*, \mathbf{v}'_{n_k} \rightarrow \mathbf{v}'_* \text{ weakly-* in } L^\infty(0,T;(L^2_\#(D_\varepsilon))^3), \\ \sum_{j=1}^3 A_{3j} \frac{\partial \int_0^t \mathbf{v}_{n_k} dt}{\partial x_j} \rightarrow \sum_{j=1}^3 A_{3j} \frac{\partial \int_0^t \mathbf{v}_* dt}{\partial x_j} \text{ weakly-* in } L^\infty(0,T;(L^2_\#(D_\varepsilon^+))^3), \\ D(\mathbf{v}_{n_k}) \rightarrow D(\mathbf{v}_*) \text{ weakly in } L^2(0,T;(L^2_\#(D^-))^9). \end{cases} \quad (2.2.18)$$

We need to show that the limit $\mathbf{v}_* \in H_v$ is solution for (2.1.12).

For passing to the limit in (2.2.1), written for the subsequences n_k , we take $\varphi = \varphi_k$ in (2.2.1)₁, we consider an arbitrary function $\eta \in L^2(0,T)$ and we compute

$$\int_0^T \sum_{k=1}^n a_k (2.2.1)_1 \cdot \eta dt, \text{ which gives}$$

$$\begin{aligned} \int_0^T \int_{D_\varepsilon} \rho_\pm \frac{\partial \mathbf{v}_n}{\partial t} \cdot \varphi \eta + \varepsilon^{-3} \int_0^T \int_{D_\varepsilon^+} \sum_{i,j=1}^3 A_{ij} \frac{\partial}{\partial x_j} \left(\int_0^t \mathbf{v}_n(s) ds \right) \frac{\partial \varphi}{\partial x_i} \eta \\ + 2\tilde{\nu} \int_0^T \int_{D^-} D(\mathbf{v}_n) : D(\varphi) \eta = \int_0^T \int_{D_\varepsilon} \mathbf{F}_\pm \cdot \varphi \eta, \end{aligned} \quad (2.2.19)$$

with $\varphi = \sum_{k=1}^n a_k \varphi_k$. We use next (2.2.18), which yields

$$\begin{aligned} & \int_0^T \int_{D_\varepsilon} \rho_\pm \frac{\partial \mathbf{v}_*}{\partial t} \cdot \varphi \eta + \varepsilon^{-3} \int_0^T \int_{D_\varepsilon^+} \sum_{i,j=1}^3 A_{ij} \frac{\partial}{\partial x_j} \left(\int_0^t \mathbf{v}_*(s) ds \right) \frac{\partial \varphi}{\partial x_i} \eta \\ & + 2\tilde{\nu} \int_0^T \int_{D^-} D(\mathbf{v}_*) : D(\varphi) \eta = \int_0^T \int_{D_\varepsilon} \mathbf{F}_\pm \cdot \varphi \eta \quad \forall \varphi \in V. \end{aligned} \quad (2.2.20)$$

To get initial condition (2.1.12)₂ we consider in (2.2.19) and (2.2.20) a more regular function $\eta \in C([0, T])$, $\eta(T) = 0$. After integration by parts in time of the first term of (2.2.19) and (2.2.20) we obtain, respectively

$$\begin{aligned} & - \int_0^T \int_{D_\varepsilon} \rho_\pm \mathbf{v}_n \cdot \varphi \eta' + \varepsilon^{-3} \int_0^T \int_{D_\varepsilon^+} \sum_{i,j=1}^3 A_{ij} \frac{\partial}{\partial x_j} \left(\int_0^t \mathbf{v}_n(s) ds \right) \frac{\partial \varphi}{\partial x_i} \eta \\ & + 2\tilde{\nu} \int_0^T \int_{D^-} D(\mathbf{v}_n) : D(\varphi) \eta = \int_0^T \int_{D_\varepsilon} \mathbf{F}_\pm \cdot \varphi \eta \quad \forall \varphi \in V \end{aligned}$$

and

$$\begin{aligned} & - \int_{D_\varepsilon} \rho_\pm \mathbf{v}_*(0) \cdot \varphi \eta(0) - \int_0^T \int_{D_\varepsilon} \rho_\pm \mathbf{v}_* \cdot \varphi \eta' + 2\tilde{\nu} \int_0^T \int_{D^-} D(\mathbf{v}_*) : D(\varphi) \eta \\ & + \varepsilon^{-3} \int_0^T \int_{D_\varepsilon^+} \sum_{i,j=1}^3 A_{ij} \frac{\partial}{\partial x_j} \left(\int_0^t \mathbf{v}_*(s) ds \right) \frac{\partial \varphi}{\partial x_i} \eta = \int_0^T \int_{D_\varepsilon} \mathbf{F}_\pm \cdot \varphi \eta \quad \forall \varphi \in V. \end{aligned}$$

As a consequence of the previous two relations and (2.2.18) we obtain $\mathbf{v}_*(0) = 0$.

In order to show the uniqueness we take $\mathbf{g} = \mathbf{0}$, $\mathbf{f} = \mathbf{0}$ in (2.1.12) and we need to prove the absence of nontrivial solutions for this problem; we take \mathbf{v}_ε as a test function

$$\left\{ \begin{array}{l} \int_{D_\varepsilon} \rho_\pm \frac{\partial \mathbf{v}_\varepsilon}{\partial t} \cdot \mathbf{v}_\varepsilon + \varepsilon^{-3} \int_{D_\varepsilon^+} \sum_{i,j=1}^3 A_{ij} \frac{\partial}{\partial x_j} \left(\int_0^t \mathbf{v}_\varepsilon(s) ds \right) \frac{\partial \mathbf{v}_\varepsilon}{\partial x_i} \cdot \mathbf{v}_\varepsilon \\ \quad + 2\tilde{\nu} \int_{D^-} D(\mathbf{v}_\varepsilon) : D(\mathbf{v}_\varepsilon) = 0 \quad \text{a.e. in } (0, T), \\ \mathbf{v}_\varepsilon(0) = \mathbf{0} \text{ in } D_\varepsilon. \end{array} \right. \quad (2.2.21)$$

A priori estimates for \mathbf{v}_ε are obtained in a similar manner to that described above (see (2.2.11), with \mathbf{v}_n replaced by \mathbf{v}_ε):

$$\begin{aligned} & \frac{c_1}{2} \|\mathbf{v}_\varepsilon\|_{L^\infty(0,T;(L^2(D_\varepsilon))^3)}^2 + 4\tilde{\nu} \|D(\mathbf{v}_\varepsilon)\|_{L^2(0,T;(L^2(D^-))^{3 \times 3})}^2 \\ & + \varepsilon^{-3} \left\| \int_{D_\varepsilon} \sum_{i,j=1}^3 A_{ij} \frac{\partial}{\partial x_j} \left(\int_0^t \mathbf{v}_\varepsilon(s) \, ds \right) \frac{\partial}{\partial x_i} \left(\int_0^t \mathbf{v}_\varepsilon(s) \, ds \right) \right\|_{L^\infty(0,T)} \leq \|\mathbf{f}, \mathbf{g}\|_1, \end{aligned} \quad (2.2.22)$$

where $\|\mathbf{f}, \mathbf{g}\|_1$ is given by (2.2.12). For an *a priori* estimate the term $\varepsilon^{-3} \left\| \int_{D_\varepsilon} \sum_{i,j=1}^3 A_{ij} \frac{\partial}{\partial x_j} \left(\int_0^t \mathbf{v}_\varepsilon(s) \, ds \right) \frac{\partial}{\partial x_i} \left(\int_0^t \mathbf{v}_\varepsilon(s) \, ds \right) \right\|_{L^\infty(0,T)}$ should be estimated below by the second Korn inequality via lower part and the trace as authors did in [62, Th. 1] using Lax-Milgram lemma [63]. In (2.2.22) it is easy to get the lower estimate carrying out a change of variables and unknowns in D_ε^+ , reducing it to the field, independent of epsilon, and using the periodicity in x_1, x_2 with the continuation through the interface Γ^0 .

From estimates (2.2.22) the uniqueness follows when $\mathbf{f} = \mathbf{g} = \mathbf{0}$.

The uniqueness result gives convergences (2.2.18) not only on subsequences, but on the whole sequences.

The pressure gradient can be constructed from the de Rham theorem [24] (as a distribution). \square

2.2.2 Limit problem

Generally the main question is the constructing of the limit problem that will be constructed in the chapter 3. For the asymptotic approach of the problem we need further regularity for the data. We suppose that

(H1) the function \mathbf{g} is independent of x_3 and $\mathbf{g} \in C^\infty([0, T], (C^\infty(\bar{D}))^3)$;

(H2) the function \mathbf{f} is C^∞ D -periodic and $\frac{\partial^l \mathbf{f}}{\partial x_{s_1} \dots \partial x_{s_l}} \in C^\infty([0, T], (L^2(D^-))^3)$,
for any $l \in \mathbb{N}$, $s = (s_1, \dots, s_l)$, $s_j \in \{1, 2\}$, $|s| = l$;

(H3) $\exists \tau_0 < T$ such that $\mathbf{f} = \mathbf{0}$ in $D^- \times [0, \tau_0]$, $\mathbf{g} = \mathbf{0}$ in $D \times [0, \tau_0]$.

Consider the following problem (for $k = 0$)

$$\left\{ \begin{array}{l} \hat{J} \Delta_{\bar{x}}^2 (w_0)_3 - p_0 \Big|_{x_3=0} = g_3 \quad \text{in } D \times (0, T), \\ \rho_- \frac{\partial \hat{\mathbf{v}}_0}{\partial t} - \tilde{\nu} \Delta \hat{\mathbf{v}}_0 + \nabla p_0 = \mathbf{f}, \\ \operatorname{div} \hat{\mathbf{v}}_0 = 0 \quad \text{in } D^- \times (0, T), \\ \hat{\mathbf{v}}_0(\bar{x}, -1, t) = \mathbf{0} \quad \text{in } D \times (0, T), \\ \hat{\mathbf{v}}_0(\bar{x}, 0, t) = \frac{\partial (w_0)_3}{\partial t}(\bar{x}, t) \mathbf{e}_3 \quad \text{in } D \times (0, T), \\ (w_0)_3, \hat{\mathbf{v}}_0, p_0 \text{ } D\text{-periodic,} \\ \hat{\mathbf{v}}_0(x, 0) = \mathbf{0} \text{ in } D^-; (w_0)_3(x, 0) = 0 \text{ in } D \end{array} \right. \quad (2.2.23)$$

with regularity for the data satisfying the hypothesis (H1)–(H3).

Problem (2.2.23) can be rewritten

$$\left\{ \begin{array}{l} \rho_- \frac{\partial \hat{\mathbf{v}}_0}{\partial t} - \tilde{\nu} \Delta \hat{\mathbf{v}}_0 + \nabla p_0 = \mathbf{f}, \\ \operatorname{div} \hat{\mathbf{v}}_0 = 0 \quad \text{in } D^- \times (0, T), \\ \hat{\mathbf{v}}_0(\bar{x}, -1, t) = \mathbf{0} \quad \text{in } D \times (0, T), \\ (\hat{v}_0)_1 = (\hat{v}_0)_2 = 0, \hat{J} \int_0^t \Delta_{\bar{x}}^2 (\hat{v}_0)_3(\bar{x}, 0, s) ds - p_0 \Big|_{\Gamma^0} = g_3 \quad \text{in } D \times (0, T), \\ \hat{\mathbf{v}}_0, p_0 \text{ } D\text{-periodic,} \\ \hat{\mathbf{v}}_0(x, 0) = \mathbf{0} \text{ in } D^-, \end{array} \right. \quad (2.2.24)$$

after using of (2.2.23)_{5,7}.

Differentiate (2.2.24)_{1–4} by t , it yields

$$\left\{ \begin{array}{l} \rho_- \hat{\mathbf{v}}_0'' - \tilde{\nu} \Delta \hat{\mathbf{v}}_0' + \nabla p_0' = \mathbf{f}', \\ \operatorname{div} \hat{\mathbf{v}}_0' = 0 \quad \text{in } D^- \times (0, T), \\ \hat{\mathbf{v}}_0'(\bar{x}, -1, t) = \mathbf{0} \quad \text{in } D \times (0, T), \\ (\hat{v}_0)'_1 = (\hat{v}_0)'_2 = 0, \hat{J} \Delta_{\bar{x}}^2 (\hat{v}_0)_3(\bar{x}, 0, s) - p_0' \Big|_{\Gamma^0} = g_3' \quad \text{in } D \times (0, T), \\ \hat{\mathbf{v}}_0, p_0 \text{ } D\text{-periodic,} \\ \hat{\mathbf{v}}_0(0) = \hat{\mathbf{v}}_0'(0) = \mathbf{0} \text{ in } D^-. \end{array} \right. \quad (2.2.25)$$

We notice that the condition $\hat{\mathbf{v}}'_0(0) = \mathbf{0}$ appears as a consequence of (H3).

Define

$$H = \left\{ \boldsymbol{\omega} \in (H_{\#}^1(D^-))^3 \mid \operatorname{div} \boldsymbol{\omega} = 0, \boldsymbol{\omega} = \mathbf{0} \text{ on } \Gamma^-, \omega_{1,2} = 0 \text{ on } \Gamma^0, \gamma_0 \omega_3 \in H^2(\Gamma^0) \right\}, \quad (2.2.26)$$

where $\gamma : (H^1(D^-))^3 \rightarrow (H^{1/2}(\partial D^-))^3$, $\gamma_0 = \gamma / \Big|_{\Gamma^0}$ is the trace operator. Such spaces [64–66] are called *strengthened Sobolev spaces*. We put

$$H_v = \left\{ \mathbf{v} \in L^2(0, T; H) \mid \mathbf{v}' \in L^2(0, T; (H_{\#}^1(D^-))^3), \mathbf{v}'' \in L^2(0, T; (L_{\#}^2(D^-))^3) \right\}. \quad (2.2.27)$$

The space H is provided with the norm

$$\|\boldsymbol{\omega}\|_H^2 = \|\boldsymbol{\omega}\|_{(H^1(D^-))^3}^2 + \|\Delta_{\bar{x}} \gamma_0 \omega_3\|_{L^2(\Gamma^0)}^2.$$

We compute $\int_{D^-} (2.2.25)_1 \cdot \boldsymbol{\varphi} + \int_{\Gamma^0} (2.2.25)_4 \cdot \gamma_0 \varphi_3$ and after integration by parts we obtain the variational formulation for our problem

$$\left\{ \begin{array}{l} \text{Find } \hat{\mathbf{v}}_0 \in H_v \text{ such that} \\ \rho_- \int_{D^-} \hat{\mathbf{v}}_0''(t) \boldsymbol{\varphi} + \tilde{\nu} \int_{D^-} \nabla \hat{\mathbf{v}}_0'(t) : \nabla \boldsymbol{\varphi} + \hat{J} \int_{\Gamma^0} \Delta_{\bar{x}}(\gamma_0(\hat{v}_0)_3)(t) \Delta_{\bar{x}}(\gamma_0 \varphi_3) \\ \quad = \int_{D^-} \mathbf{f}'(t) \boldsymbol{\varphi} + \int_{\Gamma^0} g_3'(t) \gamma_0 \varphi_3 \quad \text{a.e. in } (0, T), \forall \boldsymbol{\varphi} \in H, \\ \hat{\mathbf{v}}_0(0) = \hat{\mathbf{v}}_0'(0) = \mathbf{0} \text{ in } (L_{\#}^2(D^-))^3. \end{array} \right. \quad (2.2.28)$$

Definition 2.2. Define a weak solution to problem (2.2.25) as a function $\hat{\mathbf{v}}_0 \in H_v$ satisfying variational problem (2.2.28).

Theorem 2.3. *Let \mathbf{f} and g_3 have the regularity given by (H1)–(H3), p. 52. Then problem (2.2.28) has a unique solution, with properties:*

$$\hat{\mathbf{v}}_0' \in W^{1,\infty}(0, T; H), \quad \hat{\mathbf{v}}_0'' \in L^2(0, T; (H_{\#}^1(D^-))^3). \quad (2.2.29)$$

Proof. The space H being a separable Hilbert space with respect to $\|\cdot\|_H$ we shall apply the Galerkin's method. For this purpose we consider an orthogonal basis $\{\boldsymbol{\varphi}_j\}_{j \in \mathbb{N}}$ of the space H and we define the approximate functions $\hat{\mathbf{v}}_{0n}(x, t) =$

$\sum_{j=1}^n c_j(t) \boldsymbol{\varphi}_j(x)$. with the coefficients $c_j(t) : [0, T] \rightarrow \mathbb{R}$ uniquely determined from

$$\begin{cases} \rho_- \int_{D^-} \hat{\mathbf{v}}''_{0n} \boldsymbol{\varphi}_j + \tilde{\nu} \int_{D^-} \nabla \hat{\mathbf{v}}'_{0n} \nabla \boldsymbol{\varphi}_j + \hat{J} \int_{\Gamma^0} \Delta_{\bar{x}}(\gamma_0(\hat{v}_{0n})_3) \Delta_{\bar{x}}(\gamma_0 \boldsymbol{\varphi}_{j3}) \\ = \int_{D^-} \mathbf{f}' \boldsymbol{\varphi}_j + \int_{\Gamma^0} g'_3 \gamma_0 \boldsymbol{\varphi}_{j3} \quad \forall j = 1, \dots, n \text{ a.e. in } (0, T), \\ \hat{\mathbf{v}}_{0n}(0) = \hat{\mathbf{v}}'_{0n}(0) = \mathbf{0} \text{ in } (L^2_{\#}(D^-))^3. \end{cases} \quad (2.2.30)$$

Next we multiply (2.2.30)₁ by c'_j and sum from 1 to n . We get

$$\begin{cases} \rho_- \int_{D^-} \hat{\mathbf{v}}''_{0n} \hat{\mathbf{v}}'_{0n} + \int_{D^-} \tilde{\nu} \nabla \hat{\mathbf{v}}'_{0n} \nabla \hat{\mathbf{v}}'_{0n} + \int_{\Gamma^0} \hat{J} \Delta_{\bar{x}}(\gamma_0(\hat{v}_{0n})_3) \Delta_{\bar{x}}(\gamma_0(\hat{v}'_{0n})_3) \\ = \int_{D^-} \mathbf{f}' \hat{\mathbf{v}}'_{0n} + \int_{\Gamma^0} g'_3 \gamma_0(\hat{v}'_{0n})_3 \quad \text{a.e. in } (0, T), \forall \boldsymbol{\varphi} \in H, \\ \hat{\mathbf{v}}_{0n}(0) = \hat{\mathbf{v}}'_{0n}(0) = \mathbf{0} \text{ in } (L^2_{\#}(D^-))^3 \end{cases} \quad (2.2.31)$$

knowing that $\sum_{j=1}^n c'_j \boldsymbol{\varphi}_j = \hat{\mathbf{v}}'_{0n}$, $\sum_{j=1}^n c'_j (\boldsymbol{\varphi}_j)_3 = \gamma_0(\hat{v}'_{0n})_3$.

We majorate the right-hand side as follows

$$\begin{aligned} & \rho_- \frac{d}{dt} \int_{D^-} (\hat{\mathbf{v}}'_{0n})^2 + 2\tilde{\nu} \int_{D^-} (\nabla \hat{\mathbf{v}}'_{0n})^2 + \hat{J} \frac{d}{dt} \int_{\Gamma^0} (\Delta_{\bar{x}}(\gamma_0(\hat{v}_{0n})_3))^2 \\ & \leq 2 \|\mathbf{f}'\|_{(L^2(D^-))^3} \|\hat{\mathbf{v}}'_{0n}\|_{(L^2(D^-))^3} + 2 \|g'_3\|_{L^2(\Gamma^0)} \|\gamma_0(\hat{v}'_{0n})_3\|_{L^2(\Gamma^0)} \\ & \leq 2c_1 \|\mathbf{f}'\|_{(L^2(D^-))^3} \|\nabla \hat{\mathbf{v}}'_{0n}\|_{L^2(D^-)} + 2 \|g'_3\|_{L^2(\Gamma^0)} \|\gamma_0(\hat{v}'_{0n})_3\|_{L^2(\Gamma^0)}, \end{aligned}$$

with a constant c_1 independent of ε given by Poincaré's inequality.

Integrating in time the previous inequality and using initial conditions (2.2.31)₂ we get

$$\begin{aligned} & \rho_- \int_{D^-} (\hat{\mathbf{v}}'_{0n})^2(t) + 2\tilde{\nu} \int_0^t \int_{D^-} (\nabla \hat{\mathbf{v}}'_{0n})^2 + \hat{J} \int_{\Gamma^0} (\Delta_{\bar{x}}(\gamma_0(\hat{v}_{0n})_3))^2(t) \\ & \leq 2c_1 \int_0^t \|\mathbf{f}'\|_{(L^2(D^-))^3} \|\nabla \hat{\mathbf{v}}'_{0n}\|_{(L^2(D^-))^3} + 2 \int_0^t \|g'_3\|_{L^2(\Gamma^0)} \|\gamma_0(\hat{v}'_{0n})_3\|_{L^2(\Gamma^0)} \\ & \leq 2c_1 \int_0^t \|\mathbf{f}'\|_{(L^2(D^-))^3} \|\nabla \hat{\mathbf{v}}'_{0n}\|_{(L^2(D^-))^{3 \times 3}} + 2c_2 \int_0^t \|g'_3\|_{L^2(\Gamma^0)} \|\nabla \hat{\mathbf{v}}'_{0n}\|_{(L^2(D^-))^{3 \times 3}} \\ & \leq c_3 \left(\|\mathbf{f}'\|_{L^2(0,T;(L^2(D^-))^3)}^2 + \|g'_3\|_{L^2(0,T;L^2(\Gamma^0))}^2 \right) + \tilde{\nu} \int_0^t \int_{D^-} (\nabla \hat{\mathbf{v}}'_{0n})^2, \end{aligned}$$

using $\|\gamma_0(\hat{v}'_{0n})_3\|_{L^2(\Gamma^0)} \leq c_2 \|\nabla \hat{\mathbf{v}}'_{0n}\|_{(L^2(D^-))^{3 \times 3}}$.

So we obtain the first estimates as below

$$\max\{\rho_-^{1/2}\|\hat{\mathbf{v}}'_{0n}\|_{L^\infty(0,T;(L^2(D^-))^3)}, \tilde{\nu}^{1/2}\|\nabla\hat{\mathbf{v}}'_{0n}\|_{L^2(0,T;(L^2(D^-))^{3 \times 3})}, \hat{J}^{1/2}\|\Delta_{\bar{x}}(\gamma_0(\hat{v}_{0n})_3)\|_{L^\infty(0,T;L^2(\Gamma^0))}\} \leq \|\mathbf{f}', g'_3\|_2, \quad (2.2.32)$$

with $\|\mathbf{f}', g'_3\|_2 = (2c_3)^{1/2} (\|\mathbf{f}'\|_{L^2(0,T;(L^2(D^-))^3)} + \|g'_3\|_{L^2(0,T;L^2(\Gamma_0))})$.

Taking into account (H3) we obtain from (2.2.32) the second estimates

$$\max\{\rho_-^{1/2}\|\hat{\mathbf{v}}''_{0n}\|_{L^\infty(0,T;(L^2(D^-))^3)}, \tilde{\nu}^{1/2}\|\nabla\hat{\mathbf{v}}''_{0n}\|_{L^2(0,T;(L^2(D^-))^{3 \times 3})}, \hat{J}^{1/2}\|\Delta_{\bar{x}}(\gamma_0(\hat{v}'_{0n})_3)\|_{L^\infty(0,T;L^2(\Gamma^0))}\} \leq \|\mathbf{f}'', g''_3\|_2, \quad (2.2.33)$$

With these estimates we have the following convergences on subsequences

$$\begin{cases} \hat{\mathbf{v}}_{0n_k} \rightharpoonup \hat{\mathbf{v}}_{0*}, \hat{\mathbf{v}}'_{0n_k} \rightharpoonup \hat{\mathbf{v}}'_{0*}, \hat{\mathbf{v}}''_{0n_k} \rightharpoonup \hat{\mathbf{v}}''_{0*} \text{ weakly in } L^2(0, T; (L^2_{\#}(D^-))^3), \\ \nabla\hat{\mathbf{v}}'_{0n_k} \rightharpoonup \nabla\hat{\mathbf{v}}'_{0*} \text{ weakly in } L^2(0, T; (L^2_{\#}(D^-))^{3 \times 3}), \\ \Delta_{\bar{x}}(\gamma_0(\hat{v}_{0n_k})_3) \rightharpoonup \Delta_{\bar{x}}(\gamma_0(\hat{v}_{0*})_3) \text{ weakly} - * \text{ in } L^2(0, T; L^2_{\#}(\Gamma_0)) \end{cases} \quad (2.2.34)$$

for $k \rightarrow \infty$.

We need to show that the limit $\hat{\mathbf{v}}_{0*} \in H_v$ is the weak solution of (2.2.28).

For passing to the limit in (2.2.30), written for the subsequences n_k , we consider arbitrary functions $\eta \in L^2(0, T)$ and $\boldsymbol{\varphi} = \sum_{j=1}^n c_j \boldsymbol{\varphi}_j \in H$ and we compute $\int_0^T \sum_{j=1}^n c_j (2.2.30)_1 \cdot \eta \, dt$, which gives

$$\begin{aligned} & \rho_- \int_0^T \int_{D^-} \hat{\mathbf{v}}''_{0n} \boldsymbol{\varphi} \eta + \tilde{\nu} \int_0^T \int_{D^-} \nabla \hat{\mathbf{v}}'_{0n} \nabla \boldsymbol{\varphi} \eta + \hat{J} \int_0^T \int_{\Gamma^0} \Delta_{\bar{x}}(\gamma_0(\hat{v}_{0n})_3) \Delta_{\bar{x}}(\gamma_0 \boldsymbol{\varphi}_3) \eta \\ & = \int_0^T \int_{D^-} \mathbf{f}' \boldsymbol{\varphi} \eta + \int_0^T \int_{\Gamma^0} g'_3 \gamma_0 \boldsymbol{\varphi}_3 \eta. \end{aligned} \quad (2.2.35)$$

We use next (2.2.34), which yields

$$\begin{aligned} & \rho_- \int_{D^-} \hat{\mathbf{v}}''_{0*} \boldsymbol{\varphi} + \tilde{\nu} \int_{D^-} \nabla \hat{\mathbf{v}}'_{0*} \nabla \boldsymbol{\varphi} + \hat{J} \int_{\Gamma^0} \Delta_{\bar{x}}(\gamma_0(\hat{v}_{0*})_3) \Delta_{\bar{x}}(\gamma_0 \boldsymbol{\varphi}_3) \\ & = \int_{D^-} \mathbf{f}' \boldsymbol{\varphi} + \int_{\Gamma^0} g'_3 \gamma_0 \boldsymbol{\varphi}_3 \quad \text{a.e. in } (0, T), \forall \boldsymbol{\varphi} \in H. \end{aligned} \quad (2.2.36)$$

To get initial conditions (2.2.28)₂ we introduce the space

$$Y = \{\mathbf{v} \in L^2(0, T; (H^1_{\#}(D^-))^3), \mathbf{v}' \in L^2(0, T; (L^2_{\#}(D^-))^3)\},$$

we use the fact [24] that $Y \subset L^2(0, T; (L^2_{\#}(D^-))^3)$ is compact owing to the compactness of $(H^1_{\#}(D^-))^3 \subset (L^2_{\#}(D^-))^3$. Then applying the Poincaré's inequality, estimates (2.2.32), (2.2.33) and using the hypothesis (H3) we get the following relations

$$\begin{aligned} \|\hat{\mathbf{v}}'_{0n}\|_{L^2(0, T; (H^1_{\#}(D^-))^3)} &\leq C_1 \|\|\mathbf{f}', g'_3\|_2\|_{L^2(0, T)}, \\ \|\hat{\mathbf{v}}''_{0n}\|_{L^2(0, T; (L^2_{\#}(D^-))^3)} &\leq C_2 \|\|\mathbf{f}'', g''_3\|_2\|_{L^2(0, T)}. \end{aligned} \quad (2.2.37)$$

It signifies belonging of $\hat{\mathbf{v}}_{0n}, \hat{\mathbf{v}}'_{0n}$ to $C([0, T]; (L^2_{\#}(D^-))^3)$. The compactness of the embedding $H^1(0, T; (H^1_{\#}(D^-))^3) \subset C([0, T]; (L^2_{\#}(D^-))^3)$, initial conditions (2.2.30) give the strong convergences $\hat{\mathbf{v}}_{0n} \rightarrow \hat{\mathbf{v}}_0$ and $\hat{\mathbf{v}}'_{0n} \rightarrow \hat{\mathbf{v}}'_0$ in $C([0, T]; (L^2_{\#}(D^-))^3)$ from the weak convergences $\hat{\mathbf{v}}_{0n} \rightharpoonup \hat{\mathbf{v}}_0$ and $\hat{\mathbf{v}}'_{0n} \rightharpoonup \hat{\mathbf{v}}'_0$ in $L^2(0, T; (H^1_{\#}(D^-))^3)$. The limits $\hat{\mathbf{v}}_0, \hat{\mathbf{v}}'_0$ are also found in $C([0, T]; (L^2_{\#}(D^-))^3)$. Then the convergences $\hat{\mathbf{v}}_{0n} \rightarrow \hat{\mathbf{v}}_0$ and $\hat{\mathbf{v}}'_{0n} \rightarrow \hat{\mathbf{v}}'_0$ in $C([0, T]; (L^2_{\#}(D^-))^3)$ lead to $\hat{\mathbf{v}}_{0n}(0) \rightarrow \hat{\mathbf{v}}_0(0)$ in $(L^2_{\#}(D^-))^3$ and $\hat{\mathbf{v}}'_{0n}(0) \rightarrow \hat{\mathbf{v}}'_0(0)$ in $(L^2_{\#}(D^-))^3$ whence we have initial conditions (2.2.28)₂.

All the assertions of the theorem are obtained following the steps of the corresponding proof of [1, 2].

□

Uniqueness of $\hat{\mathbf{v}}_{0*}$. Multiply the integral identity by $\hat{\mathbf{v}}'_{0*}$. We use the energetic estimates for the difference $\hat{\mathbf{v}}_{0*}^1 - \hat{\mathbf{v}}_{0*}^2$ with right-hand side = 0.

2.3 Regularity results

2.3.1 Main problem

Improving the regularity [67], [60] is a very important question for the existence of the pressure trace on the interaction boundary Γ^0 and the further asymptotic analysis. We have already got the existence and uniqueness results for initial problem (2.1.12) in the weak sense (with the minimal regularity) by means of Galerkin's method with *a priori* estimates (2.2.22) (without pressure). We improve the data regularity for carrying out of the regularity study as follows: $\mathbf{g} \in H^2([0, T], (H^1_{\#}(D^+_{\varepsilon}))^3)$, $\mathbf{f} \in H^2([0, T], (H^1_{\#}(D^-))^3)$. We introduce new domains $D_{\varepsilon h_i}, D^+_{\varepsilon h_i}, D^-_{\varepsilon h_i}$, that are obtained from $D_{\varepsilon}, D^+_{\varepsilon}, D^-_{\varepsilon}$, respectively, with a shift in

x_i at h_i , $i = 1, 2$:

$$D_{h_1} = (h_1, 1 + h_1) \times (0, 1), \quad D_{h_2} = (0, 1) \times (h_2, 1 + h_2),$$

$$D_{\varepsilon h_i} = D_{h_i} \times (-1, \varepsilon), \quad D_{\varepsilon h_i}^+ = D_{h_i} \times (0, \varepsilon), \quad D_{h_i}^- = D_{h_i} \times (-1, 0),$$

for small h_1 and h_2 . We consider next the variables x_1 , x_2 and t consecutively. For example, we start with x_1 : to improve the regularity in x_1 we consider problem (2.1.12) with x_1 replaced by $x_1 + h_1$

$$\left\{ \begin{array}{l} \frac{d}{dt} \int_{D_{\varepsilon h_1}} \rho_{\pm} \mathbf{v}_{\varepsilon}(x_1 + h_1) \cdot \boldsymbol{\varphi} + \varepsilon^{-3} \int_{D_{\varepsilon h_1}^+} \sum_{i,j=1}^3 A_{ij} \frac{\partial}{\partial x_j} \left(\int_0^t \mathbf{v}_{\varepsilon}(x_1 + h_1) \, ds \right) \cdot \frac{\partial \boldsymbol{\varphi}}{\partial x_i} \\ + 2\tilde{\nu} \int_{D_{h_1}^-} D(\mathbf{v}_{\varepsilon}(x_1 + h_1)) : D(\boldsymbol{\varphi}) = \int_{D_{\varepsilon h_1}} \mathbf{F}_{\pm}(x_1 + h_1) \cdot \boldsymbol{\varphi} \quad \forall \boldsymbol{\varphi} \in V \text{ a.e. in } (0, T), \\ \mathbf{v}_{\varepsilon}(0) = \mathbf{0} \text{ in } D_{\varepsilon}, \end{array} \right. \quad (2.3.1)$$

and the problem corresponding to the right-hand side $\frac{\partial \mathbf{F}_{\pm}}{\partial x_1}$:

$$\left\{ \begin{array}{l} \frac{d}{dt} \int_{D_{\varepsilon}} \rho_{\pm} \mathbf{v}_{\varepsilon}^* \cdot \boldsymbol{\varphi} + \varepsilon^{-3} \int_{D_{\varepsilon}^+} \sum_{i,j=1}^3 A_{ij} \frac{\partial}{\partial x_j} \left(\int_0^t \mathbf{v}_{\varepsilon}^* \, ds \right) \cdot \frac{\partial \boldsymbol{\varphi}}{\partial x_i} \\ + 2\tilde{\nu} \int_{D^-} D(\mathbf{v}_{\varepsilon}^*) : D(\boldsymbol{\varphi}) = \int_{D_{\varepsilon}} \frac{\partial \mathbf{F}_{\pm}}{\partial x_1} \cdot \boldsymbol{\varphi} \quad \forall \boldsymbol{\varphi} \in V \text{ a.e. in } (0, T), \\ \mathbf{v}_{\varepsilon}^*(0) = \mathbf{0} \text{ in } D_{\varepsilon}. \end{array} \right. \quad (2.3.2)$$

We remark that the test function $\boldsymbol{\varphi}$ in (2.3.1) would have to be equal to $\boldsymbol{\varphi}(x_1 + h_1)$, but (2.3.1)₁ remains true for all $\boldsymbol{\varphi} \in V$. So, it can be taken $\boldsymbol{\varphi}(x_1)$. In this case problem (2.3.1) is equivalent to variational problem (2.1.12) on the score of the D-periodicity. Convergence of the finite difference $\frac{\mathbf{v}_{\varepsilon}(x_1 + h_1, x_2, x_3, t) - \mathbf{v}_{\varepsilon}(x, t)}{h_1}$ to the solution $\mathbf{v}_{\varepsilon}^*(x, t)$ of (2.3.2) can be proved as follows. Evidently, the difference $\frac{\mathbf{v}_{\varepsilon}(x_1 + h_1, x_2, x_3, t) - \mathbf{v}_{\varepsilon}(x, t)}{h_1} - \mathbf{v}_{\varepsilon}^*(x, t)$ satisfies the problem with the right-hand side $\frac{\mathbf{F}_{\pm}(x_1 + h_1, x_2, x_3, t) - \mathbf{F}_{\pm}(x, t)}{h_1} - \frac{\partial \mathbf{F}_{\pm}}{\partial x_1}(x, t)$. We apply *a priori* estimates

(2.2.22):

$$\begin{aligned}
 & \frac{c_1}{2} \left\| \frac{\mathbf{v}_\varepsilon(x_1 + h_1) - \mathbf{v}_\varepsilon(x_1)}{h_1} - \mathbf{v}_\varepsilon^* \right\|_{L^\infty(0,T;(L^2(D_\varepsilon^-))^3)}^2 \\
 & + 4\tilde{\nu} \left\| D \left(\frac{\mathbf{v}_\varepsilon(x_1 + h_1) - \mathbf{v}_\varepsilon(x_1)}{h_1} - \mathbf{v}_\varepsilon^* \right) \right\|_{L^2(0,T;(L^2(D^-))^{3 \times 3})}^2 \\
 & + \varepsilon^{-3} \left\| \int_{D_\varepsilon} \sum_{i,j=1}^3 A_{ij} \frac{\partial}{\partial x_j} \left(\int_0^t \frac{\mathbf{v}_\varepsilon(x_1 + h_1) - \mathbf{v}_\varepsilon(x_1)}{h_1} - \mathbf{v}_\varepsilon^* ds \right) \right. \\
 & \quad \left. \cdot \frac{\partial}{\partial x_i} \left(\int_0^t \frac{\mathbf{v}_\varepsilon(x_1 + h_1) - \mathbf{v}_\varepsilon(x_1)}{h_1} - \mathbf{v}_\varepsilon^* ds \right) \right\|_{L^\infty(0,T)} \\
 & \leq \left\| \frac{\mathbf{f}(x_1 + h_1) - \mathbf{f}(x_1)}{h_1} - \frac{\partial \mathbf{f}}{\partial x_1}, \frac{\mathbf{g}(x_1 + h_1) - \mathbf{g}(x_1)}{h_1} - \frac{\partial \mathbf{g}}{\partial x_1} \right\|_1.
 \end{aligned} \tag{2.3.3}$$

Due to the improved regularity of \mathbf{f} and \mathbf{g} , the right-hand side of (2.3.3) goes to zero when $h_1 \rightarrow 0$, so $\frac{\mathbf{v}_\varepsilon(x_1 + h_1, x_2, x_3, t) - \mathbf{v}_\varepsilon(x, t)}{h_1}$ tends to $\mathbf{v}_\varepsilon^*(x, t)$, when $h_1 \rightarrow 0$. From the convergence of $\frac{\mathbf{v}_\varepsilon(x_1 + h_1, x_2, x_3, t) - \mathbf{v}_\varepsilon(x, t)}{h_1}$ to $\mathbf{v}_\varepsilon^*(x, t)$ we deduce that \mathbf{v}_ε is differentiable in x_1 and, within the meaning of the generalized derivative defined by Sobolev, that the derivative $\frac{\partial \mathbf{v}_\varepsilon}{\partial x_1}$ is exactly the function \mathbf{v}_ε^* . With the same ideas, the previous result holds also for the variables x_2 and t .

We consider now the following problem

$$\left\{ \begin{array}{l}
 \rho_+ \frac{\partial^2 \mathbf{u}_\varepsilon}{\partial t^2} - \varepsilon^{-3} \sum_{i,j=1}^3 \frac{\partial}{\partial x_i} \left(A_{ij} \frac{\partial \mathbf{u}_\varepsilon}{\partial x_j} \right) = \varepsilon^{-1} \mathbf{g} \text{ in } D_\varepsilon^+ \times (0, T), \\
 \sum_{j=1}^3 A_{3j} \frac{\partial \mathbf{u}_\varepsilon}{\partial x_j} = \mathbf{0} \text{ on } \Gamma_\varepsilon^+ \times (0, T), \\
 \mathbf{u}_\varepsilon = \left(\int_0^t \mathbf{v}_\varepsilon(s) ds \right) \Big|_{\Gamma^0} \text{ on } \Gamma^0 \times (0, T), \\
 \mathbf{u}_\varepsilon \text{ } D\text{-periodic}, \\
 \mathbf{u}_\varepsilon(0) = \mathbf{u}'_\varepsilon(0) = \mathbf{0} \text{ in } D_\varepsilon^+.
 \end{array} \right. \tag{2.3.4}$$

Repeating the same arguments as above we obtain the regularity $\frac{\partial \mathbf{u}_\varepsilon}{\partial x_i}(t) \in (H^1(D_\varepsilon^+))^3, i = 1, 2$, and $\frac{\partial^2 \mathbf{u}_\varepsilon}{\partial t^2}(t) \in (L^2(D_\varepsilon^+))^3$. As the coefficients of A_{ij} are piecewise smooth functions on $[0, 1]$ as stated on p. 39, then relation (2.3.4)₁ gives

$\frac{\partial^2 \mathbf{u}_\varepsilon}{\partial x_3^2}(t) \in (L^2(D_\varepsilon^+))^3$. It means that $\mathbf{u}_\varepsilon(t) \in H^2$ in a neighborhood of Γ^0 and $(\mathbf{u}_\varepsilon)_{/\Gamma^0}(t) \in H^{3/2}(\Gamma^0)$.

Next, we consider the problem

$$\left\{ \begin{array}{l} \rho_- \frac{\partial \mathbf{v}_\varepsilon}{\partial t} - 2\tilde{\nu} \operatorname{div}(D(\mathbf{v}_\varepsilon)) + \nabla p_\varepsilon = \mathbf{f} \quad \text{in } D^- \times (0, T), \\ \operatorname{div} \mathbf{v}_\varepsilon = 0 \quad \text{in } D^- \times (0, T), \\ \mathbf{v}_\varepsilon = \mathbf{0} \text{ on } \Gamma^- \times (0, T), \\ \mathbf{v}_\varepsilon = \frac{\partial \mathbf{u}_\varepsilon}{\partial t} \Big|_{\Gamma^0} \text{ on } \Gamma^0 \times (0, T), \\ \mathbf{v}_\varepsilon, p_\varepsilon \quad D\text{-periodic}, \\ \mathbf{v}_\varepsilon(0) = \mathbf{0} \text{ in } D^-. \end{array} \right. \quad (2.3.5)$$

From (2.3.5)₄ we get $\mathbf{v}_\varepsilon \in (H^{3/2}(\partial D^-))^3$. Using the regularity previously obtained for the derivatives in x_1 , x_2 and t for \mathbf{v}_ε , we obtain from equation (2.3.5)₁ the condition $\nabla p_\varepsilon(t) \in (H_{\#}^1(D^-))^3$. The ADN-estimates [24] give the following regularity $\mathbf{v}_\varepsilon(t) \in (H^2(D^-))^3$, $p_\varepsilon(t) \in H^1(D^-)$. Consequently, the trace $p_\varepsilon|_{\Gamma^0}$ has the regularity $H^{1/2}$.

2.3.2 Limit problem

The regularity question is very important in the asymptotic analysis because there are the higher-order derivatives taken with respect to t and x_1 , x_2 from the unknowns $(w_0)_3$, $\hat{\mathbf{v}}_0$, p_0 (obtained in solving the limit problem) in the asymptotics construction.

Let us consider variational problem (2.2.28) at the moment $t + \Delta t \in (0, T)$ (Δt is small)

$$\left\{ \begin{array}{l} \rho_- \int_{D^-} \hat{\mathbf{v}}_0''(t + \Delta t) \boldsymbol{\varphi}_j + \tilde{\nu} \int_{D^-} \nabla \hat{\mathbf{v}}_0'(t + \Delta t) \nabla \boldsymbol{\varphi}_j + \hat{J} \int_{\Gamma^0} \Delta_{\bar{x}} \gamma_0(\hat{v}_0)_3(t + \Delta t) \Delta_{\bar{x}} \gamma_0 \boldsymbol{\varphi}_{j3} \\ = \int_{D^-} \mathbf{f}'(t + \Delta t) \boldsymbol{\varphi}_j + \int_{\Gamma^0} g_3'(t + \Delta t) \gamma_0 \boldsymbol{\varphi}_{j3}, j = 1, \dots, n, \\ \hat{\mathbf{v}}_0(0) = \hat{\mathbf{v}}_0'(0) = \mathbf{0} \text{ in } (L_{\#}^2(D^-))^3, \end{array} \right. \quad (2.3.6)$$

and problem (2.2.30) replacing \mathbf{f}' and g'_3 in the right-hand side by its derivatives

$$\left\{ \begin{array}{l} \rho_- \int_{D^-} \hat{\mathbf{v}}''_{0*} \boldsymbol{\varphi}_j + \tilde{\nu} \int_{D^-} \nabla \hat{\mathbf{v}}'_{0*} \nabla \boldsymbol{\varphi}_j + \hat{J} \int_{\Gamma^0} \Delta_{\bar{x}}(\gamma_0(\hat{\mathbf{v}}_{0*})_3) \Delta_{\bar{x}}(\gamma_0 \boldsymbol{\varphi}_{j3}) \\ = \int_{D^-} \mathbf{f}'' \boldsymbol{\varphi}_j + \int_{\Gamma^0} g''_3 \gamma_0 \boldsymbol{\varphi}_{j3} \quad \text{a.e. in } (0, T), j = 1, \dots, n, \\ \hat{\mathbf{v}}_{0*}(0) = \hat{\mathbf{v}}'_{0*}(0) = \mathbf{0} \text{ in } (L^2_{\#}(D^-))^3. \end{array} \right. \quad (2.3.7)$$

Remark. The initial condition $\hat{\mathbf{v}}'_{0*}(0) = \mathbf{0}$ is obtained automatically from the fourth hypothesis for \mathbf{f} and g_3 (see asymptotic analysis).

We consider the difference between $\frac{(2.3.6)_1 - (2.2.30)_1}{\Delta t}$ and (2.3.7)₁:

$$\begin{aligned} & \rho_- \int_{D^-} \left(\frac{\hat{\mathbf{v}}''_0(t + \Delta t) - \hat{\mathbf{v}}''_0(t)}{\Delta t} - \hat{\mathbf{v}}''_{0*}(t) \right) \boldsymbol{\varphi}_j \\ & + \tilde{\nu} \int_{D^-} \left(\frac{\nabla \hat{\mathbf{v}}'_0(t + \Delta t) - \nabla \hat{\mathbf{v}}'_0(t)}{\Delta t} - \nabla \hat{\mathbf{v}}'_{0*}(t) \right) \nabla \boldsymbol{\varphi}_j \\ & + \hat{J} \int_{\Gamma^0} \left(\frac{\Delta_{\bar{x}} \gamma_0(\hat{v}_0)_3(t + \Delta t) - \Delta_{\bar{x}} \gamma_0(\hat{v}_0)_3(t)}{\Delta t} - \Delta_{\bar{x}} \gamma_0(\hat{\mathbf{v}}_{0*})_3(t) \right) \Delta_{\bar{x}} \gamma_0 \boldsymbol{\varphi}_{j3} \\ & = \int_{D^-} \left(\frac{\mathbf{f}'(t + \Delta t) - \mathbf{f}'(t)}{\Delta t} - \mathbf{f}''(t) \right) \boldsymbol{\varphi}_j \\ & + \int_{\Gamma^0} \left(\frac{g'_3(t + \Delta t) - g'_3(t)}{\Delta t} - g''_3(t) \right) \gamma_0 \boldsymbol{\varphi}_{j3}, j = 1, \dots, n, \end{aligned} \quad (2.3.8)$$

We obtain the estimates

$$\begin{aligned} & \left\| \frac{\hat{\mathbf{v}}'_0(t + \Delta t) - \hat{\mathbf{v}}'_0(t)}{\Delta t} - \hat{\mathbf{v}}'_{0*}(t) \right\|_{C([0, T]; (L^2(D^-))^3)} \\ & + \left\| \frac{\nabla \hat{\mathbf{v}}'_0(t + \Delta t) - \nabla \hat{\mathbf{v}}'_0(t)}{\Delta t} - \nabla \hat{\mathbf{v}}'_{0*}(t) \right\|_{L^2(0, T; (L^2(D^-))^3)} \\ & + \left\| \frac{\Delta_{\bar{x}} \gamma_0(\hat{v}_0)_3(t + \Delta t) - \Delta_{\bar{x}} \gamma_0(\hat{v}_0)_3(t)}{\Delta t} - \Delta_{\bar{x}} \gamma_0(\hat{\mathbf{v}}_{0*})_3(t) \right\|_{L^\infty(0, T; L^2(\Gamma^0))} \\ & \leq C \left\| \mathbf{c} \left(\frac{\mathbf{f}'(t + \Delta t) - \mathbf{f}'(t)}{\Delta t} - \mathbf{f}''(t), \frac{g'_3(t + \Delta t) - g'_3(t)}{\Delta t} - g''_3(t) \right) \right\|_{L^2(0, T)}. \end{aligned} \quad (2.3.9)$$

Knowing, that

$$\mathbf{f}''(t) = \lim_{\Delta t \rightarrow 0} \frac{\mathbf{f}'(t + \Delta t) - \mathbf{f}'(t)}{\Delta t}, \quad g''_3(t) = \lim_{\Delta t \rightarrow 0} \frac{g'_3(t + \Delta t) - g'_3(t)}{\Delta t}$$

we obtain the following convergences

$$\begin{aligned} \frac{\hat{\mathbf{v}}'_0(t + \Delta t) - \hat{\mathbf{v}}'_0(t)}{\Delta t} &\rightarrow \hat{\mathbf{v}}'_{0*}(t), \quad \Delta t \rightarrow 0, \\ \frac{\nabla \hat{\mathbf{v}}'_0(t + \Delta t) - \nabla \hat{\mathbf{v}}'_0(t)}{\Delta t} &\rightarrow \nabla \hat{\mathbf{v}}'_{0*}(t), \quad \Delta t \rightarrow 0, \\ \frac{\Delta_{\bar{x}} \gamma_0(\hat{v}_0)_3(t + \Delta t) - \Delta_{\bar{x}} \gamma_0(\hat{v}_0)_3(t)}{\Delta t} &\rightarrow \Delta_{\bar{x}} \gamma_0(\hat{\mathbf{v}}_{0*})_3(t), \quad \Delta t \rightarrow 0. \end{aligned}$$

The limit of $\frac{\hat{\mathbf{v}}'_0(t+\Delta t) - \hat{\mathbf{v}}'_0(t)}{\Delta t}$ will be the function in H_v because $\frac{\hat{\mathbf{v}}'_0(t+\Delta t) - \hat{\mathbf{v}}'_0(t)}{\Delta t} \in H_v$ which is the closed Hilbert space and contains its limit points. In plus, $\hat{\mathbf{v}}'_{0*}$ will be the second derivative $\hat{\mathbf{v}}''_0(t)$. In fact, if our sequence converges weakly, we can choose a convergent subsequence in the classical sense in L^2 and its limit will be needed derivative.

Analogically it is possible to get all derivatives in time of $\hat{\mathbf{v}}_0$ by induction.

Next, we do the same to the derivatives with respect to the space variables x_1 and x_2 . This gives the estimates (for $i = 1, 2$)

$$\begin{aligned} &\left\| \frac{\hat{\mathbf{v}}'_0(x_i + \Delta x_i) - \hat{\mathbf{v}}'_0(x_i)}{\Delta x_i} - \frac{\partial \hat{\mathbf{v}}'_0}{\partial x_i} \right\|_{C([0,T];(L^2(D^-))^3)} \\ &+ \left\| \frac{\nabla \hat{\mathbf{v}}'_0(x_i + \Delta x_i) - \nabla \hat{\mathbf{v}}'_0(x_i)}{\Delta x_i} - \frac{\partial \nabla \hat{\mathbf{v}}'_0}{\partial x_i} \right\|_{L^2(0,T;(L^2(D^-))^3)} \\ &+ \left\| \frac{\Delta_{\bar{x}} \gamma_0(\hat{v}_0)_3(x_i + \Delta x_i) - \Delta_{\bar{x}} \gamma_0(\hat{v}_0)_3(x_i)}{\Delta x_i} - \frac{\partial \Delta_{\bar{x}} \gamma_0(\hat{v}_0)_3}{\partial x_i} \right\|_{L^\infty(0,T;L^2(\Gamma^0))} \\ &\leq C \left\| \mathbf{c} \left(\frac{\mathbf{f}'(x_i + \Delta x_i) - \mathbf{f}'(x_i)}{\Delta x_i} - \frac{\partial \mathbf{f}'}{\partial x_i}, \frac{g'_3(x_i + \Delta x_i) - g'_3(x_i)}{\Delta x_i} - \frac{\partial g'_3}{\partial x_i} \right) \right\|_{L^2(0,T)}. \end{aligned} \tag{2.3.10}$$

It means the convergences

$$\begin{aligned} \frac{\hat{\mathbf{v}}'_0(x_i + \Delta x_i) - \hat{\mathbf{v}}'_0(x_i)}{\Delta x_i} &\rightarrow \frac{\partial \hat{\mathbf{v}}'_0}{\partial x_i}, \quad \Delta x_i \rightarrow 0, \\ \frac{\nabla \hat{\mathbf{v}}'_0(x_i + \Delta x_i) - \nabla \hat{\mathbf{v}}'_0(x_i)}{\Delta x_i} &\rightarrow \frac{\partial \nabla \hat{\mathbf{v}}'_0}{\partial x_i}, \quad \Delta x_i \rightarrow 0, \\ \frac{\Delta_{\bar{x}} \gamma_0(\hat{v}_0)_3(x_i + \Delta x_i) - \Delta_{\bar{x}} \gamma_0(\hat{v}_0)_3(x_i)}{\Delta x_i} &\rightarrow \frac{\partial \Delta_{\bar{x}} \gamma_0(\hat{v}_0)_3}{\partial x_i}, \quad \Delta x_i \rightarrow 0. \end{aligned}$$

The derivative $\frac{\partial \hat{\mathbf{v}}'_0}{\partial x_i}$, $i \in \{1, 2\}$ will be in the our space too (remark, that 1-periodicity is saved) and we obtain other derivatives of bigger order by induction.

In order to get the derivatives $\frac{\partial^k \hat{\mathbf{v}}'_0}{\partial x_3^k}$, $k \geq 1$ we replace the initial problem by the Dirichlet problem and we apply for it the ADN-estimates [24].

As stated above, there exist the unique solution to problem (2.2.23), but there is no information for the reverse transition from the variational problem (without pressure) to a physical problem (with pressure).

Remark. The formal differentiations in (2.2.23), (2.2.24), (2.2.25) become informal with the results of applying the smoothness increasing method.

In order to improve the regularity of the unknowns as stated in Theorem 3.5, for any $q, l \in \mathbb{N}$ we consider the problem

$$\left\{ \begin{array}{l} \hat{J} \Delta_{\bar{x}}^2 (w_{q,l})_3 - p_{q,l}/_{x_3=0} = \frac{\partial^{q+l} g_3}{\partial t^q \partial x_{s_1} \dots \partial x_{s_l}} \quad \text{in } D \times (0, T), \\ \rho_- \frac{\partial \hat{\mathbf{v}}_{q,l}}{\partial t} - \tilde{\nu} \Delta \hat{\mathbf{v}}_{q,l} + \nabla p_{q,l} = \frac{\partial^{q+l} \mathbf{f}}{\partial t^q \partial x_{s_1} \dots \partial x_{s_l}} \quad \text{in } D^- \times (0, T), \\ \operatorname{div} \hat{\mathbf{v}}_{q,l} = 0 \\ \hat{\mathbf{v}}_{q,l}(\bar{x}, -1, t) = \mathbf{0} \quad \text{in } D \times (0, T), \\ \hat{\mathbf{v}}_{q,l}(\bar{x}, 0, t) = \frac{\partial (w_{q,l})_3}{\partial t}(\bar{x}, t) \mathbf{e}_3 \quad \text{in } D \times (0, T), \\ (w_{q,l})_3, \hat{\mathbf{v}}_0, p_0 \quad D\text{-periodic}, \\ \hat{\mathbf{v}}_{q,l}(x, 0) = \mathbf{0} \text{ in } D^-; (w_{q,l})_3(\bar{x}, 0) = \frac{\partial (w_{q,l})_3}{\partial t}(\bar{x}, 0) = 0 \text{ in } D. \end{array} \right. \quad (2.3.11)$$

Taking into account the assumptions (H1) and (H2) we obtain for the unknowns of (2.3.11) the same regularity as that for $(w_0)_3, \hat{\mathbf{v}}_0, p_0$.

We extend next problem (2.2.23) from the bounded domain D^- to the layer

corresponding to $\bar{x} \in \mathbb{R}^2$:

$$\left\{ \begin{array}{l} \hat{J} \Delta_{\bar{x}}^2 (w_0)_3 - p_{0/x_3=0} = g_3 \quad \text{in } \mathbb{R}^2 \times (0, T), \\ \rho_- \frac{\partial \hat{\mathbf{v}}_0}{\partial t} - \tilde{\nu} \Delta \hat{\mathbf{v}}_0 + \nabla p_0 = \mathbf{f} \quad \text{in } \mathbb{R}^2 \times (-1, 0) \times (0, T), \\ \operatorname{div} \hat{\mathbf{v}}_0 = 0 \\ \hat{\mathbf{v}}_0(\bar{x}, -1, t) = \mathbf{0} \quad \text{in } \mathbb{R}^2 \times (0, T), \\ \hat{\mathbf{v}}_0(\bar{x}, 0, t) = \frac{\partial (w_0)_3}{\partial t}(\bar{x}, t) \mathbf{e}_3 \quad \text{in } \mathbb{R}^2 \times (0, T), \\ \hat{\mathbf{v}}_0(x, 0) = \mathbf{0} \text{ in } \mathbb{R}^2 \times (-1, 0); (w_0)_3(\bar{x}, 0) = \frac{\partial (w_0)_3}{\partial t}(\bar{x}, 0) = 0 \text{ in } \mathbb{R}^2. \end{array} \right. \quad (2.3.12)$$

□

2.4 Conclusion

We have proved the existence and uniqueness of solution to the viscous fluid-thin elastic plate interaction problem, assuming the interface continuity of velocity and normal stresses. Variational analysis of the weak formulation is effectuated. The higher regularity of the solution is obtained. The existence of pressure follows from De Rham's theorem and its regularity. The same arguments and conclusions are right for the limit problem.

Chapter 3

Asymptotic analysis of a viscous fluid-thin plate interaction problem

3.1 Introduction

In order to construct an asymptotic expansion the existence, uniqueness and regularity of solution to the elasticity problem coupled with Stokes equations are required. We will construct the asymptotic expansion solution compared to the small parameter ε and prove estimates for the difference of the exact solution and the partial sums of the asymptotic expansion. The principal question is to find the zero approximation (satisfying the existence, uniqueness and regularity results from Chapter 2). This problem generalizes the result in two-dimensional case obtained in [1, 2]. Admittedly, the 3D model is more adequate, because in the mentioned articles it was assumed that the density of the plate is of order ε^{-1} while in the thesis densities of the plate and the fluid are of the same order, which is more realistic for applications. In section 3.2 an asymptotic solution of order J is constructed and the limit problem is obtained. This limit problem differs from that of [2], due to the change of the density order. The asymptotic expansion is completely justified in section 3.3, where the error between the exact and the asymptotic solutions is evaluated.

In this chapter we deal with the equations with rapidly oscillating coefficients [55, 68–72]. Heterogeneous composite materials consist of a plurality of other substantially smaller (*microscale*) materials with different thermomechanical properties. But usually it is very important to know how composite will behave on the whole (*macroscale*) rather than each of its components separately:

for engineers the main criteria are the stability of the material to loads, the melting point of the composite as a homogeneous material and other (chapter 1). For example, the coefficients of thermal conductivity in the system of equations of elasticity theory (stationary), which describes the temperature distribution in the material are rapidly oscillating functions that depend on the “fast variable $\xi = \frac{x}{\varepsilon}$. The variable x is then called “slow. And they are considered to be independent. This is the basis of the method twoscale (and multiscale) expansions [73, 74] with homogenisation [75, 76]. Typically, the solution of the problem is sought in the form of an asymptotic series (Ansatz). The main issue is to construct the limit problem when $\varepsilon \rightarrow 0$ with constant coefficients (as averaging), it characterizes the general properties of the composite material as a uniform.

The method of partial asymptotic decomposition of the domain (see [71]) allows to reduce the dimension in some part of a thin domain and to glue the models of different dimension at the interface. The idea of coupling models of different dimension or different scales ([77–81]) is an important trend in the domain decomposition approach. It is applied in the blood circulation modelling (see e.g. [82, 83]) and in engineering [71].

3.2 Construction of an asymptotic expansion of the solution to the problem

As it was suggested in the chapter 2 for the asymptotic approach of the problem we need regularity for the data given by four hypothesis (H1)-(H3), p. 52.

We look for an asymptotic solution of order J for (2.1.1) in the form

$$\begin{aligned}
\mathbf{u}_\varepsilon^{(J)}(x, t) &= \sum_{q+l=0}^J \varepsilon^{q+l} \sum_{\substack{s:|s|=l \\ s_j \in \{1,2\}}} N_{q, s_1 \dots s_l}(\xi_3) \frac{\partial^{q+l} \mathbf{w}_\varepsilon^{(J)}(\bar{x}, t)}{\partial t^q \partial x_{s_1} \dots \partial x_{s_l}} \\
&+ \sum_{q+l=0}^J \varepsilon^{q+l+2} \sum_{\substack{s:|s|=l \\ s_j \in \{1,2\}}} M_{q, s_1 \dots s_l}(\xi_3) \frac{\partial^{q+l} \boldsymbol{\psi}_\varepsilon^{(J)}(\bar{x}, t)}{\partial t^q \partial x_{s_1} \dots \partial x_{s_l}}, \\
&\hspace{20em} (x, t) \in D_\varepsilon^+ \times (0, T), \\
\left\{ \begin{array}{l} \mathbf{v}_\varepsilon^{(J)}(x, t) = \sum_{k=0}^J \varepsilon^k \mathbf{v}_k(x, t), \\ p_\varepsilon^{(J)}(x, t) = \sum_{k=0}^J \varepsilon^k p_k(x, t), \end{array} \right. &\hspace{10em} (x, t) \in D^- \times (0, T), \\
\boldsymbol{\psi}_\varepsilon^{(J)}(\bar{x}, t) &= 2\tilde{\nu} D(\mathbf{v}_\varepsilon^{(J)}(\bar{x}, 0, t)) \mathbf{e}_3 - p_\varepsilon^{(J)}(\bar{x}, 0, t) \mathbf{e}_3, \\
&\hspace{20em} (\bar{x}, t) \in D \times (0, T), \\
\mathbf{w}_\varepsilon^{(J)}(\bar{x}, t) &= \sum_{k=0}^J \varepsilon^k \mathbf{w}_k(\bar{x}, t), \quad (\bar{x}, t) \in D \times (0, T),
\end{aligned} \tag{3.2.1}$$

with \mathbf{w}_k , \mathbf{v}_k , p_k D -periodic, for any $k \in \{0, 1, \dots, J\}$ and ξ_3 is introduced in (2.1.2).

Remark. For any fixed value of J the required smoothness of the data \mathbf{f} and \mathbf{g} may be reduced to the class $C^{\alpha(J)}$ with respect to x_1 , x_2 and t variables, where $\alpha(J)$ is some finite number depending on J , chosen in such a way that all the derivatives of $\mathbf{w}_\varepsilon^{(J)}$ and $\boldsymbol{\psi}_\varepsilon^{(J)}$ in (3.2.2) exist and belong to C^2 . However, we consider in what follows the regularity given by (H1) and (H2), in order to ensure the necessary smoothness for an asymptotic solution of any arbitrary order.

To determine the asymptotic solution means to determine the matrices $N_{q, s_1 \dots s_l} = N_{q, s_1 \dots s_l}(\xi_3)$, $M_{q, s_1 \dots s_l} = M_{q, s_1 \dots s_l}(\xi_3)$, $N_{q, s_1 \dots s_l}$, $M_{q, s_1 \dots s_l} \in \mathcal{M}_{3,3}$ and the functions $\mathbf{v}_k = \mathbf{v}_k(x, t)$, $p_k = p_k(x, t)$, $\mathbf{w}_k = \mathbf{w}_k(\bar{x}, t)$. All these functions depend on ε but we omit the subscript ε .

We introduce the following notation for the left hand side of (2.1.1)₁

$$P_\varepsilon \mathbf{u}_\varepsilon = \rho_+(\xi_3) \frac{\partial^2 \mathbf{u}_\varepsilon}{\partial t^2} - \varepsilon^{-3} \sum_{i,j=1}^3 \frac{\partial}{\partial x_i} \left(A_{ij}(\xi_3) \frac{\partial \mathbf{u}_\varepsilon}{\partial x_j} \right). \tag{3.2.2}$$

Let us replace in (3.2.2) \mathbf{u}_ε with its asymptotic expansion (3.2.1)₁.

Applying the chain rule, producing index changing, identifying some indexes we obtain for $J > 4$

$$\begin{aligned} P_\varepsilon \mathbf{u}_\varepsilon^{(J)} &= \sum_{q+l=0}^J \varepsilon^{q+l-5} \sum_{s:|s|=l} H_{q, s_1 \dots s_l}^N(\xi_3) \frac{\partial^{q+l} \mathbf{w}_\varepsilon^{(J)}(\bar{x}, t)}{\partial t^q \partial x_{s_1} \dots \partial x_{s_l}} \\ &+ \sum_{q+l=0}^J \varepsilon^{q+l-3} \sum_{s:|s|=l} H_{q, s_1 \dots s_l}^M(\xi_3) \frac{\partial^{q+l} \boldsymbol{\psi}_\varepsilon^{(J)}(\bar{x}, t)}{\partial t^q \partial x_{s_1} \dots \partial x_{s_l}} + \mathbf{r}_\varepsilon^{(J),1}, \end{aligned} \quad (3.2.3)$$

where a.e. in $[0, 1]$

$$\left\{ \begin{aligned} H_{q, s_1 \dots s_l}^N(\xi_3) &= \varepsilon^3 \rho_+(\xi_3) N_{q-2, s_1 \dots s_l}(\xi_3) - \left((A_{33}(\xi_3) N'_{q, s_1 \dots s_l}(\xi_3))' \right. \\ &\quad \left. + (A_{3s_1}(\xi_3) N_{q, s_2 \dots s_l}(\xi_3))' + A_{s_1 3}(\xi_3) N'_{q, s_2 \dots s_l}(\xi_3) + A_{s_1 s_2}(\xi_3) N_{q, s_3 \dots s_l}(\xi_3) \right), \\ H_{q, s_1 \dots s_l}^M(\xi_3) &= \varepsilon^3 \rho_+(\xi_3) M_{q-2, s_1 \dots s_l}(\xi_3) - \left((A_{33}(\xi_3) M'_{q, s_1 \dots s_l}(\xi_3))' \right. \\ &\quad \left. + (A_{3s_1}(\xi_3) M_{q, s_2 \dots s_l}(\xi_3))' + A_{s_1 3}(\xi_3) M'_{q, s_2 \dots s_l}(\xi_3) + A_{s_1 s_2}(\xi_3) M_{q, s_3 \dots s_l}(\xi_3) \right) \end{aligned} \right. \quad (3.2.4)$$

and

$$\left\{ \begin{aligned} \mathbf{r}_\varepsilon^{(J),1}(\bar{x}, \xi_3, t) &= \varepsilon^{J-4} \sum_{q+l=J+1}^{J+1} \left(\varepsilon^3 \rho_+(\xi_3) N_{q-2, s_1 \dots s_l}(\xi_3) - \left((A_{3s_1}(\xi_3) N_{q, s_2 \dots s_l}(\xi_3))' \right. \right. \\ &\quad \left. \left. + A_{s_1 3}(\xi_3) N'_{q, s_2 \dots s_l}(\xi_3) + A_{s_1 s_2}(\xi_3) N_{q, s_3 \dots s_l}(\xi_3) \right) \right) \frac{\partial^{q+l} \mathbf{w}_\varepsilon^{(J)}(\bar{x}, t)}{\partial t^q \partial x_{s_1} \dots \partial x_{s_l}} \\ &+ \varepsilon^{J-3} \sum_{q+l=J+2}^{J+2} \left(\varepsilon^3 \rho_+(\xi_3) N_{q-2, s_1 \dots s_l}(\xi_3) - A_{s_1 s_2}(\xi_3) N_{q, s_3 \dots s_l}(\xi_3) \right) \frac{\partial^{q+l} \mathbf{w}_\varepsilon^{(J)}(\bar{x}, t)}{\partial t^q \partial x_{s_1} \dots \partial x_{s_l}} \\ &+ \varepsilon^{J-2} \sum_{q+l=J+1}^{J+1} \left(\varepsilon^3 \rho_+(\xi_3) M_{q-2, s_1 \dots s_l}(\xi_3) - \left((A_{3s_1}(\xi_3) M_{q, s_2 \dots s_l}(\xi_3))' \right. \right. \\ &\quad \left. \left. + A_{s_1 3}(\xi_3) M'_{q, s_2 \dots s_l}(\xi_3) + A_{s_1 s_2}(\xi_3) M_{q, s_3 \dots s_l}(\xi_3) \right) \right) \frac{\partial^{q+l} \boldsymbol{\psi}_\varepsilon^{(J)}(\bar{x}, t)}{\partial t^q \partial x_{s_1} \dots \partial x_{s_l}} \\ &+ \varepsilon^{J-1} \sum_{q+l=J+2}^{J+2} \left(\varepsilon^3 \rho_+(\xi_3) M_{q-2, s_1 \dots s_l}(\xi_3) - A_{s_1 s_2}(\xi_3) M_{q, s_3 \dots s_l}(\xi_3) \right) \frac{\partial^{q+l} \boldsymbol{\psi}_\varepsilon^{(J)}(\bar{x}, t)}{\partial t^q \partial x_{s_1} \dots \partial x_{s_l}}, \end{aligned} \right. \quad (3.2.5)$$

with $s_j \in \{1, 2\}$.

Since $P_\varepsilon \mathbf{u}_\varepsilon^{(J)}$ should be equal to $\varepsilon^{-1} \mathbf{g}(\bar{x}, t)$, we seek the matrices $N_{q, s_1 \dots s_l}$ and

$M_{q, s_1 \dots s_l}$ such that $H_{q, s_1 \dots s_l}^N$ and $H_{q, s_1 \dots s_l}^M$ have constant matrix values. In this way we obtain the equations for determining the matrices $N_{q, s_1 \dots s_l}$, $M_{q, s_1 \dots s_l}$ as follows

$$\begin{cases} H_{q, s_1 \dots s_l}^N(\xi_3) = -h_{q, s_1 \dots s_l}^N, \\ H_{q, s_1 \dots s_l}^M(\xi_3) = -h_{q, s_1 \dots s_l}^M, \end{cases} \quad (3.2.6)$$

where $h_{q, s_1 \dots s_l}^N$ and $h_{q, s_1 \dots s_l}^M$ are constant matrices.

The left hand side of (2.1.1)₄ written for $\mathbf{u}_\varepsilon^{(J)}$ has the expression

$$\begin{aligned} & \sum_{j=1}^3 A_{3j}(1) \frac{\partial \mathbf{u}_\varepsilon^{(J)}}{\partial x_j}(\bar{x}, \varepsilon, t) \\ &= \sum_{j=1}^3 A_{3j}(1) \frac{\partial \mathbf{u}_\varepsilon^{(J)}}{\partial x_j}(\bar{x}, \varepsilon, t) + \varepsilon^{-1} \sum_{j=1}^3 A_{3j}(1) \frac{\partial \mathbf{u}_\varepsilon^{(J)}}{\partial \xi_j}(\bar{x}, \varepsilon, t) \\ &= \sum_{q+l=0}^J \varepsilon^{q+l} \sum_{j=1}^3 \sum_{s:|s|=l} A_{3j}(1) N_{q, s_1 \dots s_l}(1) \frac{\partial^{q+l+1} \mathbf{w}_\varepsilon^{(J)}(\bar{x}, t)}{\partial t^q \partial x_j \partial x_{s_1} \dots \partial x_{s_l}} \\ &+ \sum_{q+l=0}^J \varepsilon^{q+l+2} \sum_{j=1}^3 \sum_{s:|s|=l} A_{3j}(1) M_{q, s_1 \dots s_l}(1) \frac{\partial^{q+l+1} \boldsymbol{\psi}_\varepsilon^{(J)}(\bar{x}, t)}{\partial t^q \partial x_j \partial x_{s_1} \dots \partial x_{s_l}} \\ &+ \sum_{q+l=0}^J \varepsilon^{q+l-1} \sum_{s:|s|=l} A_{33}(1) \frac{\partial N_{q, s_1 \dots s_l}}{\partial \xi_3}(1) \frac{\partial^{q+l} \mathbf{w}_\varepsilon^{(J)}(\bar{x}, t)}{\partial t^q \partial x_{s_1} \dots \partial x_{s_l}} \\ &+ \sum_{q+l=0}^J \varepsilon^{q+l+1} \sum_{s:|s|=l} A_{33}(1) \frac{\partial M_{q, s_1 \dots s_l}}{\partial \xi_3}(1) \frac{\partial^{q+l} \boldsymbol{\psi}_\varepsilon^{(J)}(\bar{x}, t)}{\partial t^q \partial x_{s_1} \dots \partial x_{s_l}}. \end{aligned}$$

After index changing $l_1 = l + 1$, $s_1 = j$ and grouping terms of the same order

$$\begin{aligned} & \sum_{j=1}^3 A_{3j}(1) \frac{\partial \mathbf{u}_\varepsilon^{(J)}}{\partial x_j}(\bar{x}, \varepsilon, t) \\ &= \sum_{q+l=0}^J \varepsilon^{q+l-1} \sum_{s:|s|=l} (A_{3s_1}(1) N_{q, s_2 \dots s_l}(1) + A_{33}(1) N'_{q, s_1 \dots s_l}(1)) \frac{\partial^{q+l} \mathbf{w}_\varepsilon^{(J)}(\bar{x}, t)}{\partial t^q \partial x_{s_1} \dots \partial x_{s_l}} \\ &+ \sum_{q+l=0}^J \varepsilon^{q+l+1} \sum_{s:|s|=l} (A_{3s_1}(1) M_{q, s_2 \dots s_l}(1) + A_{33}(1) M'_{q, s_1 \dots s_l}(1)) \frac{\partial^{q+l} \boldsymbol{\psi}_\varepsilon^{(J)}(\bar{x}, t)}{\partial t^q \partial x_{s_1} \dots \partial x_{s_l}} \\ &+ \mathbf{r}_\varepsilon^{(J),4}(\bar{x}, t), \end{aligned} \quad (3.2.7)$$

where

$$\begin{aligned} \mathbf{r}_\varepsilon^{(J),4}(\bar{x}, t) &= \varepsilon^J \sum_{q+l=J+1}^{J+1} \sum_{s:|s|=l} A_{3s_1}(1) N_{q, s_2 \dots s_l}(1) \frac{\partial^{J+1} \mathbf{w}_\varepsilon^{(J)}(\bar{x}, t)}{\partial t^q \partial x_{s_1} \dots \partial x_{s_l}} \\ &+ \varepsilon^{J+2} \sum_{q+l=J+1}^{J+1} \sum_{s:|s|=l} A_{3s_1}(1) M_{q, s_2 \dots s_l}(1) \frac{\partial^{J+1} \boldsymbol{\psi}_\varepsilon^{(J)}(\bar{x}, t)}{\partial t^q \partial x_{s_1} \dots \partial x_{s_l}}. \end{aligned} \quad (3.2.8)$$

Satisfying boundary condition (2.1.1)₄ with the residual of order ε^J we get

$$\begin{cases} A_{33}(1) N'_{q, s_1 \dots s_l}(1) + A_{3s_1}(1) N_{q, s_2 \dots s_l}(1) = O_3, \\ A_{33}(1) M'_{q, s_1 \dots s_l}(1) + A_{3s_1}(1) M_{q, s_2 \dots s_l}(1) = O_3, \end{cases} \quad s_j \in \{1, 2\}. \quad (3.2.9)$$

Introducing expansion (3.2.1)₁ in the right hand side of (2.1.1)₇ and using (3.2.1)₄ we obtain, as before

$$\begin{aligned} &-p_\varepsilon^{(J)}(\bar{x}, 0, t) \mathbf{e}_3 + 2\tilde{\nu} D(\mathbf{v}_\varepsilon^{(J)}(\bar{x}, 0, t)) \mathbf{e}_3 - \varepsilon^{-3} \sum_{j=1}^3 A_{3j}(0) \frac{\partial \mathbf{u}_\varepsilon^{(J)}}{\partial x_j}(\bar{x}, 0, t) \\ &= \boldsymbol{\psi}_\varepsilon^{(J)}(\bar{x}, t) - \varepsilon^{-3} \left(\sum_{q+l=0}^J \varepsilon^{q+l} \sum_{j=1}^3 \sum_{s:|s|=l} A_{3j}(0) N_{q, s_1 \dots s_l}(0) \frac{\partial^{q+l+1} \mathbf{w}_\varepsilon^{(J)}(\bar{x}, t)}{\partial t^q \partial x_j \partial x_{s_1} \dots \partial x_{s_l}} \right. \\ &\quad + \sum_{q+l=0}^J \varepsilon^{q+l+2} \sum_{j=1}^3 \sum_{s:|s|=l} A_{3j}(0) M_{q, s_1 \dots s_l}(0) \frac{\partial^{q+l+1} \boldsymbol{\psi}_\varepsilon^{(J)}(\bar{x}, t)}{\partial t^q \partial x_j \partial x_{s_1} \dots \partial x_{s_l}} \\ &\quad + \sum_{q+l=0}^J \varepsilon^{q+l-1} \sum_{s:|s|=l} A_{33}(0) \frac{\partial N_{q, s_1 \dots s_l}}{\partial \xi_3}(0) \frac{\partial^{q+l} \mathbf{w}_\varepsilon^{(J)}(\bar{x}, t)}{\partial t^q \partial x_{s_1} \dots \partial x_{s_l}} \\ &\quad \left. + \sum_{q+l=0}^J \varepsilon^{q+l+1} \sum_{s:|s|=l} A_{33}(0) \frac{\partial M_{q, s_1 \dots s_l}}{\partial \xi_3}(0) \frac{\partial^{q+l} \boldsymbol{\psi}_\varepsilon^{(J)}(\bar{x}, t)}{\partial t^q \partial x_{s_1} \dots \partial x_{s_l}} \right), \end{aligned}$$

wherefrom it follows that

$$\begin{aligned} &-p_\varepsilon^{(J)}(\bar{x}, 0, t) \mathbf{e}_3 + 2\tilde{\nu} D(\mathbf{v}_\varepsilon^{(J)}(\bar{x}, 0, t)) \mathbf{e}_3 - \varepsilon^{-3} \sum_{j=1}^3 A_{3j}(0) \frac{\partial \mathbf{u}_\varepsilon^{(J)}}{\partial x_j}(\bar{x}, 0, t) \\ &= \boldsymbol{\psi}_\varepsilon^{(J)}(\bar{x}, t) - \sum_{q+l=0}^J \varepsilon^{q+l-4} \sum_{s:|s|=l} (A_{3s_1}(0) N_{q, s_2 \dots s_l}(0) + A_{33}(0) N'_{q, s_1 \dots s_l}(0)) \frac{\partial^{q+l} \mathbf{w}_\varepsilon^{(J)}(\bar{x}, t)}{\partial t^q \partial x_{s_1} \dots \partial x_{s_l}} \\ &\quad - \sum_{q+l=0}^J \varepsilon^{q+l-2} \sum_{s:|s|=l} (A_{3s_1}(0) M_{q, s_2 \dots s_l}(0) + A_{33}(0) M'_{q, s_1 \dots s_l}(0)) \frac{\partial^{q+l} \boldsymbol{\psi}_\varepsilon^{(J)}(\bar{x}, t)}{\partial t^q \partial x_{s_1} \dots \partial x_{s_l}} - \mathbf{r}_\varepsilon^{(J),7}(\bar{x}, t), \end{aligned}$$

with

$$\begin{aligned} \mathbf{r}_\varepsilon^{(J),7}(\bar{x}, t) &= \varepsilon^{J-3} \sum_{q+l=J+1}^{J+1} \sum_{s:|s|=l} A_{3s_1}(0) N_{q, s_2 \dots s_l}(0) \frac{\partial^{J+1} \mathbf{w}_\varepsilon^{(J)}(\bar{x}, t)}{\partial t^q \partial x_{s_1} \dots \partial x_{s_l}} \\ &+ \varepsilon^{J-1} \sum_{q+l=J+1}^{J+1} \sum_{s:|s|=l} A_{3s_1}(0) M_{q, s_2 \dots s_l}(0) \frac{\partial^{J+1} \boldsymbol{\psi}_\varepsilon^{(J)}(\bar{x}, t)}{\partial t^q \partial x_{s_1} \dots \partial x_{s_l}}, \end{aligned} \quad (3.2.10)$$

and relation (2.1.1)₇ is satisfied with a small residual if

$$\begin{cases} A_{33}(0) N'_{q, s_1 \dots s_l}(0) + A_{3s_1}(0) N_{q, s_2 \dots s_l}(0) = O_3, \\ \varepsilon^{-2} (A_{33}(0) M'_{q, s_1 \dots s_l}(0) + A_{3s_1}(0) M_{q, s_2 \dots s_l}(0)) = I_3 \delta_{q0} \delta_{l0}, \end{cases} \quad s_j \in \{1, 2\}. \quad (3.2.11)$$

In what follows we shall use the notations

$$\begin{cases} \langle F \rangle = \int_0^1 F(s) ds, \\ \bar{F}(x) = x \langle F \rangle - \int_0^x F(s) ds, \\ \underline{F}(x) = \left\langle \int_0^\theta F(s) ds \right\rangle - \int_0^x F(s) ds, \end{cases} \quad (3.2.12)$$

where $F : [0, 1] \mapsto \mathbb{R}$ is an integrable function. The notation $\langle \cdot \rangle$ will be used as well for functions of several variables and in this case it concerns the variable x_1 :

$$\langle F(x_1, t) \rangle = \int_0^1 F(s, t) ds.$$

Using equations (3.2.6) and conditions (3.2.9), (3.2.11) we obtain next the problems for $N_{q, s_1 \dots s_l}$ and $M_{q, s_1 \dots s_l}$.

From (3.2.4)₁, (3.2.6)₁, (3.2.9)₁, (3.2.11)₁ with the additional conditions

$$\begin{cases} \langle N_{q, s_1 \dots s_l} \rangle = O_3 \quad \forall q + l > 0, \\ N_{0, \emptyset} = I_3 \end{cases} \quad (3.2.13)$$

we get for $N_{q, s_1 \dots s_l}$, $\forall q + l > 0$ the second order differential problem

$$\left\{ \begin{array}{l} (A_{33}N'_{q, s_1 \dots s_l} + A_{3s_1}N_{q, s_2 \dots s_l})' = -A_{s_1 3}N'_{q, s_2 \dots s_l} - A_{s_1 s_2}N_{q, s_3 \dots s_l} \\ \quad + \varepsilon^3 \rho_+ N_{q-2, s_1 \dots s_l} + h_{q, s_1 \dots s_l}^N, \\ h_{q, s_1 \dots s_l}^N = \langle A_{s_1 3}N'_{q, s_2 \dots s_l} + A_{s_1 s_2}N_{q, s_3 \dots s_l} - \varepsilon^3 \rho_+ N_{q-2, s_1 \dots s_l} \rangle, \\ A_{33}(0)N'_{q, s_1 \dots s_l}(0) = -A_{3s_1}(0)N_{q, s_2 \dots s_l}(0), \\ \langle N_{q, s_1 \dots s_l} \rangle = O_3. \end{array} \right. \quad (3.2.14)$$

In the same way, from (3.2.4)₂, (3.2.6)₂, (3.2.9)₂, (3.2.11)₂, with the additional condition

$$M_{q, s_1 \dots s_l}(0) = O_3 \quad \forall q + l \geq 0 \quad (3.2.15)$$

we obtain for $M_{q, s_1 \dots s_l}$ the problem

$$\left\{ \begin{array}{l} (A_{33}M'_{q, s_1 \dots s_l} + A_{3s_1}M_{q, s_2 \dots s_l})' = -A_{s_1 3}M'_{q, s_2 \dots s_l} - A_{s_1 s_2}M_{q, s_3 \dots s_l} \\ \quad + \varepsilon^3 \rho_+ M_{q-2, s_1 \dots s_l} + h_{q, s_1 \dots s_l}^M, \\ h_{q, s_1 \dots s_l}^M = \langle A_{s_1 3}M'_{q, s_2 \dots s_l} + A_{s_1 s_2}M_{q, s_3 \dots s_l} - \varepsilon^3 \rho_+ M_{q-2, s_1 \dots s_l} \rangle - \varepsilon^2 I_3 \delta_{q0} \delta_{l0}, \\ A_{33}(0)M'_{q, s_1 \dots s_l}(0) = \varepsilon^2 I_3 \delta_{q0} \delta_{l0}, \\ M_{q, s_1 \dots s_l}(0) = O_3. \end{array} \right. \quad (3.2.16)$$

Remark. Equation (3.2.14)₁ is interpreted in the sense of the variational formulation in H^1 . It means that it is satisfied everywhere except for the points $\zeta_1, \dots, \zeta_{p-1}$ in the classical sense and in each point $\zeta_\alpha, \alpha = 1, \dots, p-1$ two junction conditions are satisfied: $[N_{q, s_1 \dots s_l}] = O_3$, $[A_{33}N'_{q, s_1 \dots s_l} + A_{3s_1}N_{q, s_2 \dots s_l}] = O_3$, where $[R(\xi_3)] = \lim_{\xi_3 \rightarrow \zeta_\alpha + 0} R(\xi_3) - \lim_{\xi_3 \rightarrow \zeta_\alpha - 0} R(\xi_3)$.

The same remark holds for (3.2.16)₁. These junction conditions, together with the smoothness of $\mathbf{w}_\varepsilon^{(J)}$ and $\boldsymbol{\psi}_\varepsilon^{(J)}$ imply the corresponding junction conditions for the function $\mathbf{u}_\varepsilon^{(J)}$ and for the normal stress $\sum_{j=1}^3 A_{3j} \frac{\partial \mathbf{u}_\varepsilon^{(J)}}{\partial x_j}$.

Solving recursively problems (3.2.14) and (3.2.16) we compute the matrices $N_{q, s_1 \dots s_l}$, $h_{q, s_1 \dots s_l}^N$ and $M_{q, s_1 \dots s_l}$, $h_{q, s_1 \dots s_l}^M$, respectively. Concerning $h_{q, s_1 \dots s_l}^N$, we are interested to know explicitly $h_{q, s_1 \dots s_l}^N$, $q + l \leq 4$. Using expression (3.2.14)₂ and

the formula for $N_{q, s_1 \dots s_l}$, easily obtained by integrating of relation (3.2.14)₁

$$(A_{33}N'_{q, s_1 \dots s_l} + A_{3s_1}N_{q, s_2 \dots s_l})' = -A_{s_1 3}N'_{q, s_2 \dots s_l} - A_{s_1 s_2}N_{q, s_3 \dots s_l} + \varepsilon^3 \rho_+ N_{q-2, s_1 \dots s_l} + h_{q, s_1 \dots s_l}^N,$$

$$A_{33}N'_{q, s_1 \dots s_l} + A_{3s_1}N_{q, s_2 \dots s_l} = - \int_0^{\xi_3} \left(A_{s_1 3}N'_{q, s_2 \dots s_l} + A_{s_1 s_2}N_{q, s_3 \dots s_l} - \varepsilon^3 \rho_+ N_{q-2, s_1 \dots s_l} \right) ds \\ + h_{q, s_1 \dots s_l}^N \xi_3 = \overline{A_{s_1 3}N'_{q, s_2 \dots s_l} + A_{s_1 s_2}N_{q, s_3 \dots s_l} - \varepsilon^3 \rho_+ N_{q-2, s_1 \dots s_l}},$$

$$N'_{q, s_1 \dots s_l} = A_{33}^{-1} \left(-A_{3s_1}N_{q, s_2 \dots s_l} + \overline{A_{s_1 3}N'_{q, s_2 \dots s_l} + A_{s_1 s_2}N_{q, s_3 \dots s_l} - \varepsilon^3 \rho_+ N_{q-2, s_1 \dots s_l}} \right),$$

$$N_{q, s_1 \dots s_l} = \overline{A_{33}^{-1} \left(A_{3s_1}N_{q, s_2 \dots s_l} - \overline{A_{s_1 3}N'_{q, s_2 \dots s_l} + A_{s_1 s_2}N_{q, s_3 \dots s_l} - \varepsilon^3 \rho_+ N_{q-2, s_1 \dots s_l}} \right)}$$

we can find consecutively

$$1) h_{0, \emptyset}^N = O_3, N_{0, \emptyset} = I_3,$$

$$2) h_{0, s_1}^N = O_3, N_{0, 1} = \underline{A_{33}^{-1} A_{3s_1} N_{0, \emptyset}},$$

2.1) $s_1 = 1$:

$$N'_{0, 1}(\xi_3) = -A_{33}^{-1}(\xi_3)A_{31}(\xi_3) \\ = - \begin{pmatrix} \frac{2(1+\nu)}{E} & 0 & 0 \\ 0 & \frac{2(1+\nu)}{E} & 0 \\ 0 & 0 & \frac{(1+\nu)(1-2\nu)}{E(1-\nu)} \end{pmatrix} \cdot \begin{pmatrix} 0 & 0 & \frac{E}{2(1+\nu)} \\ 0 & 0 & 0 \\ \frac{E\nu}{(1+\nu)(1-2\nu)} & 0 & 0 \end{pmatrix} \\ = \begin{pmatrix} 0 & 0 & -1 \\ 0 & 0 & 0 \\ -\frac{\nu}{1-\nu} & 0 & 0 \end{pmatrix}, \\ N_{0, 1}(\xi_3) = \begin{pmatrix} 0 & 0 & \frac{1}{2} - \xi_3 \\ 0 & 0 & 0 \\ \frac{\nu}{1-\nu} & 0 & 0 \end{pmatrix},$$

2.2) $s_1 = 2$:

$$\begin{aligned}
N'_{0,2} &= -A_{33}^{-1}(\xi_3)A_{32}(\xi_3) \\
&= - \begin{pmatrix} \frac{2(1+\nu)}{E} & 0 & 0 \\ 0 & \frac{2(1+\nu)}{E} & 0 \\ 0 & 0 & \frac{(1+\nu)(1-2\nu)}{E(1-\nu)} \end{pmatrix} \cdot \begin{pmatrix} 0 & 0 & 0 \\ 0 & 0 & \frac{E}{2(1+\nu)} \\ 0 & \frac{E\nu}{(1+\nu)(1-2\nu)} & 0 \end{pmatrix} \\
&= \begin{pmatrix} 0 & 0 & 0 \\ 0 & 0 & -1 \\ 0 & -\frac{\nu}{1-\nu} & 0 \end{pmatrix}, \\
N_{0,2} &= \begin{pmatrix} 0 & 0 & 0 \\ 0 & 0 & \frac{1}{2} - \xi_3 \\ 0 & \frac{\nu}{1-\nu} & 0 \end{pmatrix},
\end{aligned}$$

3) $h_{0,s_1s_2}^N = \langle A_{s_13}N'_{0,s_2} + A_{s_1s_2} \rangle$,

$$\begin{aligned}
N'_{0,s_1s_2} &= A_{33}^{-1} \left(-A_{3s_1}N_{0,s_2} + \overline{A_{s_13}N'_{0,s_2} + A_{s_1s_2}} \right), \\
N_{0,s_1s_2} &= \overline{A_{33}^{-1} \left(A_{3s_1}N_{0,s_2} - \overline{A_{s_13}N'_{0,s_2} + A_{s_1s_2}} \right)},
\end{aligned}$$

3.1) $s_1 = 1, s_2 = 1$:

$$\begin{aligned}
h_{0,11}^N &= \begin{pmatrix} \langle \frac{E}{1-\nu^2} \rangle & 0 & 0 \\ 0 & \langle \frac{E}{2(1+\nu)} \rangle & 0 \\ 0 & 0 & 0 \end{pmatrix}, \\
N_{0,11} &= \begin{pmatrix} \frac{\nu}{1-\nu} - \frac{2(1+\nu)\overline{E}}{E(1-\nu^2)} & 0 & 0 \\ 0 & -\frac{1+\nu}{E} \frac{\overline{E}}{1+\nu} & 0 \\ 0 & 0 & \frac{\nu(\frac{1}{2}-\xi_3)}{1-\nu} \end{pmatrix},
\end{aligned}$$

3.2) $s_1 = 1, s_2 = 2$:

$$h_{0,12}^N = \begin{pmatrix} 0 & \left\langle \frac{E\nu}{1-\nu^2} \right\rangle & 0 \\ \left\langle \frac{E}{2(1+\nu)} \right\rangle & 0 & 0 \\ 0 & 0 & 0 \end{pmatrix},$$

$$N_{0,12} = \begin{pmatrix} 0 & \frac{\nu}{1-\nu} - \frac{2(1+\nu)\overline{E\nu}}{E(1-\nu^2)} & 0 \\ -\frac{1+\nu}{E} \frac{\overline{E}}{1+\nu} & 0 & 0 \\ 0 & 0 & 0 \end{pmatrix},$$

3.3) $s_1 = 2, s_2 = 1$:

$$h_{0,21}^N = \begin{pmatrix} 0 & \left\langle \frac{E}{2(1+\nu)} \right\rangle & 0 \\ \left\langle \frac{E\nu}{1-\nu^2} \right\rangle & 0 & 0 \\ 0 & 0 & 0 \end{pmatrix},$$

$$N_{0,21} = \begin{pmatrix} 0 & -\frac{1+\nu}{E} \frac{\overline{E}}{1+\nu} & 0 \\ \frac{\nu}{1-\nu} - \frac{2(1+\nu)\overline{E\nu}}{E(1-\nu^2)} & 0 & 0 \\ 0 & 0 & 0 \end{pmatrix},$$

3.4) $s_1 = 2, s_2 = 2$:

$$h_{0,22}^N = \begin{pmatrix} \left\langle \frac{E}{2(1+\nu)} \right\rangle & 0 & 0 \\ 0 & \left\langle \frac{E}{1-\nu^2} \right\rangle & 0 \\ 0 & 0 & 0 \end{pmatrix},$$

$$N_{0,22} = \begin{pmatrix} -\frac{1+\nu}{E} \frac{\overline{E}}{1+\nu} & 0 & 0 \\ 0 & \frac{\nu}{1-\nu} - \frac{2(1+\nu)\overline{E}}{E(1-\nu^2)} & 0 \\ 0 & 0 & \frac{\nu(\frac{1}{2}-\xi_3)}{1-\nu} \end{pmatrix},$$

so

$$h_{0,1,1}^N = h_{0,12}^N + h_{0,21}^N = \begin{pmatrix} 0 & \left\langle \frac{E}{2(1-\nu)} \right\rangle & 0 \\ \left\langle \frac{E}{2(1-\nu)} \right\rangle & 0 & 0 \\ 0 & 0 & 0 \end{pmatrix},$$

where the coefficient at $\frac{\partial^{q+r+p} \mathbf{w}_\varepsilon^{(J)}(\bar{x}, t)}{\partial t^q \partial x_1^r \partial x_2^p}$ in the first sum of (3.2.3) is de-

noted by $h_{q,r,p}^N$ (here and below),

$$4) \ h_{0,s_1s_2s_3}^N = \langle A_{s_13}N'_{0,s_2s_3} + A_{s_1s_2}N_{0,s_3} \rangle,$$

$$N'_{0,s_1s_2s_3} = A_{33}^{-1} \left(-A_{3s_1}N_{0,s_2} + \overline{A_{s_13}N'_{0,s_2s_3} + A_{s_1s_2}N_{0,s_3}} \right),$$

$$N_{0,s_1s_2s_3} = \overline{A_{33}^{-1} \left(A_{3s_1}N_{0,s_2} - \overline{A_{s_13}N'_{0,s_2s_3} + A_{s_1s_2}N_{0,s_3}} \right)},$$

4.1) $s_1 = 1, s_2 = 1, s_3 = 1$:

$$h_{0,111}^N = \begin{pmatrix} 0 & 0 & \left\langle \frac{E(\frac{1}{2}-\xi_3)}{1-\nu^2} \right\rangle \\ 0 & 0 & 0 \\ \left\langle \frac{E}{1-\nu^2} \right\rangle & 0 & 0 \end{pmatrix},$$

$$N_{0,111} = \begin{pmatrix} 0 & 0 & \frac{\nu(\frac{1}{2}-\xi_3)}{1-\nu} - \frac{2(1+\nu)}{E} \frac{\overline{E(\frac{1}{2}-\xi_3)}}{1-\nu^2} \\ 0 & 0 & 0 \\ \frac{\nu}{1-\nu} \frac{\nu}{1-\nu} - \frac{2(1+\nu)}{E} \frac{\overline{E}}{1-\nu^2} - \frac{(1+\nu)(1-2\nu)}{E(1-\nu)} \frac{\overline{\overline{E}}}{1-\nu^2} & 0 & 0 \end{pmatrix},$$

4.2) $s_1 = 1, s_2 = 1, s_3 = 2$:

$$h_{0,112}^N = \begin{pmatrix} 0 & 0 & 0 \\ 0 & 0 & \left\langle \frac{E(\frac{1}{2}-\xi_3)}{2(1+\nu)} \right\rangle \\ 0 & \left\langle \frac{E\nu}{1-\nu^2} \right\rangle & 0 \end{pmatrix},$$

$$N_{0,112} = \begin{pmatrix} 0 & 0 & 0 \\ 0 & 0 & \frac{-1+\nu}{E} \frac{\overline{E(\frac{1}{2}-\xi_3)}}{1+\nu} \\ 0 & \frac{\nu}{1-\nu} \frac{\nu}{1-\nu} - \frac{2(1+\nu)}{E} \frac{\overline{E\nu}}{1-\nu^2} - \frac{(1+\nu)(1-2\nu)}{E(1-\nu)} \frac{\overline{\overline{E\nu}}}{1-\nu^2} & 0 \end{pmatrix},$$

4.3) $s_1 = 1, s_2 = 2, s_3 = 1$:

$$h_{0,121}^N = \begin{pmatrix} 0 & 0 & 0 \\ 0 & 0 & \left\langle \frac{E(\frac{1}{2}-\xi_3)}{2(1+\nu)} \right\rangle \\ 0 & \left\langle \frac{E}{2(1+\nu)} \right\rangle & 0 \end{pmatrix},$$

$$N_{0,121} = \begin{pmatrix} 0 & 0 & 0 \\ 0 & 0 & -\frac{1+\nu}{E} \frac{E(\frac{1}{2}-\xi_3)}{1+\nu} \\ 0 & -\frac{\nu}{1-\nu} \frac{1+\nu}{E} \frac{E}{1+\nu} - \frac{(1+\nu)(1-2\nu)}{E(1-\nu)} \frac{E}{2(1+\nu)} & 0 \end{pmatrix},$$

4.4) $s_1 = 1, s_2 = 2, s_3 = 2$:

$$h_{0,122}^N = \begin{pmatrix} 0 & 0 & \left\langle \frac{E\nu(\frac{1}{2}-\xi_3)}{1-\nu^2} \right\rangle \\ 0 & 0 & 0 \\ \left\langle \frac{E}{2(1+\nu)} \right\rangle & 0 & 0 \end{pmatrix},$$

$$N_{0,122} = \begin{pmatrix} 0 & 0 & 0 \\ 0 & 0 & 0 \\ -\frac{\nu}{1-\nu} \frac{1+\nu}{E} \frac{E}{1+\nu} - \frac{(1+\nu)(1-2\nu)}{E(1-\nu)} \frac{E}{2(1+\nu)} & 0 & 0 \end{pmatrix},$$

$$\begin{pmatrix} 0 & \frac{\nu(\frac{1}{2}-\xi_3)}{1-\nu} - \frac{2(1+\nu)}{E} \frac{E\nu(\frac{1}{2}-\xi_3)}{1-\nu^2} \\ 0 & 0 \\ 0 & 0 \end{pmatrix},$$

4.5) $s_1 = 2, s_2 = 1, s_3 = 1$:

$$h_{0,211}^N = \begin{pmatrix} 0 & 0 & 0 \\ 0 & 0 & \left\langle \frac{E\nu(\frac{1}{2}-\xi_3)}{1-\nu^2} \right\rangle \\ 0 & \left\langle \frac{E}{2(1+\nu)} \right\rangle & 0 \end{pmatrix},$$

$$N_{0,211} = \begin{pmatrix} 0 & 0 & 0 \\ 0 & 0 & \frac{\nu(\frac{1}{2}-\xi_3)}{1-\nu} - \frac{2(1+\nu)}{E} \frac{E\nu(\frac{1}{2}-\xi_3)}{1-\nu^2} \\ 0 & -\frac{\nu}{1-\nu} \frac{1+\nu}{E} \frac{E}{1+\nu} - \frac{(1+\nu)(1-2\nu)}{E(1-\nu)} \frac{E}{2(1+\nu)} & 0 \end{pmatrix},$$

4.6) $s_1 = 2, s_2 = 1, s_3 = 2$:

$$h_{0,212}^N = \begin{pmatrix} 0 & 0 & \left\langle \frac{E(\frac{1}{2}-\xi_3)}{2(1+\nu)} \right\rangle \\ 0 & 0 & 0 \\ \left\langle \frac{E}{2(1+\nu)} \right\rangle & 0 & 0 \end{pmatrix},$$

$$N_{0,212} = \begin{pmatrix} 0 & 0 & -\frac{1+\nu}{E} \frac{\overline{E(\frac{1}{2}-\xi_3)}}{1+\nu} \\ 0 & 0 & 0 \\ -\frac{\nu}{1-\nu} \frac{1+\nu}{E} \frac{\overline{E}}{1+\nu} - \frac{(1+\nu)(1-2\nu)}{E(1-\nu)} \frac{\overline{\overline{E}}}{2(1+\nu)} & 0 & 0 \end{pmatrix},$$

4.7) $s_1 = 2, s_2 = 2, s_3 = 1$:

$$h_{0,221}^N = \begin{pmatrix} 0 & 0 & \left\langle \frac{E(\frac{1}{2}-\xi_3)}{2(1+\nu)} \right\rangle \\ 0 & 0 & 0 \\ \left\langle \frac{E\nu}{1-\nu^2} \right\rangle & 0 & 0 \end{pmatrix},$$

$$N_{0,221} = \begin{pmatrix} 0 & 0 & -\frac{1+\nu}{E} \frac{\overline{E(\frac{1}{2}-\xi_3)}}{1+\nu} \\ 0 & 0 & 0 \\ \frac{\nu}{1-\nu} \frac{\nu}{1-\nu} - \frac{2(1+\nu)}{E} \frac{\overline{E\nu}}{1-\nu^2} - \frac{(1+\nu)(1-2\nu)}{E(1-\nu)} \frac{\overline{\overline{E\nu}}}{1-\nu^2} & 0 & 0 \end{pmatrix},$$

4.8) $s_1 = 2, s_2 = 2, s_3 = 2$:

$$h_{0,222}^N = \begin{pmatrix} 0 & 0 & 0 \\ 0 & 0 & \left\langle \frac{E(\frac{1}{2}-\xi_3)}{1-\nu^2} \right\rangle \\ 0 & \left\langle \frac{E}{1-\nu^2} \right\rangle & 0 \end{pmatrix},$$

$$N_{0,222} = \begin{pmatrix} 0 & 0 & 0 \\ 0 & 0 & \frac{\nu(\frac{1}{2}-\xi_3)}{1-\nu} - \frac{2(1+\nu)}{E} \frac{\overline{E(\frac{1}{2}-\xi_3)}}{1-\nu^2} \\ 0 & \frac{\nu}{1-\nu} \frac{\nu}{1-\nu} - \frac{2(1+\nu)}{E} \frac{\overline{E}}{1-\nu^2} - \frac{(1+\nu)(1-2\nu)}{E(1-\nu)} \frac{\overline{\overline{E}}}{1-\nu^2} & 0 \end{pmatrix},$$

so

$$h_{0,2,1}^N = h_{0,112}^N + h_{0,121}^N + h_{0,211}^N = \begin{pmatrix} 0 & 0 & 0 \\ 0 & 0 & \left\langle \frac{E(\frac{1}{2}-\xi_3)}{1-\nu^2} \right\rangle \\ 0 & \left\langle \frac{E}{1-\nu^2} \right\rangle & 0 \end{pmatrix},$$

$$N_{0,2,1} = \begin{pmatrix} 0 & 0 & 0 \\ 0 & 0 & \frac{\nu(\frac{1}{2}-\xi_3)}{1-\nu} - \frac{2(1+\nu)}{E} \frac{E(\frac{1}{2}-\xi_3)}{1-\nu^2} \\ 0 & \frac{\nu}{1-\nu} \frac{\nu}{1-\nu} - \frac{2(1+\nu)}{E} \frac{E}{1-\nu^2} - \frac{(1+\nu)(1-2\nu)}{E(1-\nu)} \frac{E}{1-\nu^2} & 0 \end{pmatrix},$$

$$h_{0,1,2}^N = h_{0,122}^N + h_{0,212}^N + h_{0,221}^N = \begin{pmatrix} 0 & 0 & \left\langle \frac{E(\frac{1}{2}-\xi_3)}{1-\nu^2} \right\rangle \\ 0 & 0 & 0 \\ \left\langle \frac{E}{1-\nu^2} \right\rangle & 0 & 0 \end{pmatrix},$$

$$N_{0,1,2} = \begin{pmatrix} 0 & 0 & \frac{\nu(\frac{1}{2}-\xi_3)}{1-\nu} - \frac{2(1+\nu)}{E} \frac{E(\frac{1}{2}-\xi_3)}{1-\nu^2} \\ 0 & 0 & 0 \\ \frac{\nu}{1-\nu} \frac{\nu}{1-\nu} - \frac{2(1+\nu)}{E} \frac{E}{1-\nu^2} - \frac{(1+\nu)(1-2\nu)}{E(1-\nu)} \frac{E}{1-\nu^2} & 0 & 0 \end{pmatrix},$$

5)

$$h_{0,1111}^N = \begin{pmatrix} * & 0 & 0 \\ 0 & * & 0 \\ 0 & 0 & \left\langle \frac{E(\frac{1}{2}-\xi_3)}{1-\nu^2} \right\rangle \end{pmatrix}, h_{0,2222}^N = \begin{pmatrix} * & 0 & 0 \\ 0 & * & 0 \\ 0 & 0 & \left\langle \frac{E(\frac{1}{2}-\xi_3)}{1-\nu^2} \right\rangle \end{pmatrix},$$

$$h_{0,3,1}^N = \begin{pmatrix} 0 & * & 0 \\ * & 0 & 0 \\ 0 & 0 & 0 \end{pmatrix}, h_{0,2,2}^N = \begin{pmatrix} * & 0 & 0 \\ 0 & * & 0 \\ 0 & 0 & \left\langle \frac{E(1-2\xi_3)}{1-\nu^2} \right\rangle \end{pmatrix}, h_{0,1,3}^N = \begin{pmatrix} 0 & * & 0 \\ * & 0 & 0 \\ 0 & 0 & 0 \end{pmatrix},$$

6) $h_{1,\emptyset}^N = O_3, N_{1,\emptyset} = O_3,$

7) $h_{1,s_1}^N = O_3, N_{1,s_1} = O_3,$

8) $h_{1,s_1s_2}^N = O_3, N_{1,s_1s_2} = O_3,$

9) $h_{1,s_1s_2s_3}^N = O_3, N_{1,s_1s_2s_3} = O_3,$

$$10) h_{2,\emptyset}^N = -\varepsilon^3 \langle \rho_+ \rangle I_3,$$

$$N_{2,\emptyset} = \varepsilon^3 \begin{pmatrix} \frac{2(1+\nu)\overline{\rho_+}}{E} & 0 & 0 \\ 0 & \frac{2(1+\nu)\overline{\rho_+}}{E} & 0 \\ 0 & 0 & \frac{(1+\nu)(1-2\nu)\overline{\rho_+}}{E(1-\nu)} \end{pmatrix},$$

$$11) h_{2,s_1}^N = \left\langle A_{s_1 3} N'_{2,\emptyset} - \varepsilon^3 \rho_+ N_{0,s_1} \right\rangle,$$

$$11.1) s_1 = 1:$$

$$h_{2,1}^N = \begin{pmatrix} 0 & 0 & -\varepsilon^3 \left\langle \overline{\rho_+} \frac{\nu}{1-\nu} + \rho_+ \left(\frac{1}{2} - \xi_3 \right) \right\rangle \\ 0 & 0 & 0 \\ -\varepsilon^3 \left\langle \overline{\rho_+} + \rho_+ \frac{\nu}{1-\nu} \right\rangle & 0 & 0 \end{pmatrix},$$

$$11.2) s_1 = 2:$$

$$h_{2,2}^N = \begin{pmatrix} 0 & 0 & 0 \\ 0 & 0 & -\varepsilon^3 \left\langle \overline{\rho_+} \frac{\nu}{1-\nu} + \rho_+ \left(\frac{1}{2} - \xi_3 \right) \right\rangle \\ 0 & -\varepsilon^3 \left\langle \overline{\rho_+} + \rho_+ \frac{\nu}{1-\nu} \right\rangle & 0 \end{pmatrix},$$

$$12) h_{3,\emptyset}^N = O_3, N_{3,\emptyset} = O_3,$$

$$13) h_{3,s_1}^N = O_3, N_{3,s_1} = O_3.$$

We didn't write above the matrices $h_{2,s_1 s_2}^N$ and $h_{4,\emptyset}^N$ since they are of the form $h_{2,s_1 s_2}^N = \mathcal{O}(\varepsilon^3)$, $h_{4,\emptyset}^N = \mathcal{O}(\varepsilon^6)$.

Concerning problems (3.2.16) we prove next the following result

Proposition 3.1. $M_{q,s_1 \dots s_l} = \varepsilon^2 \tilde{M}_{q,s_1 \dots s_l}$, $h_{q,s_1 \dots s_l}^M = \varepsilon^2 \tilde{h}_{q,s_1 \dots s_l}^M \quad \forall q + l \geq 0$, where $\tilde{M}_{q,s_1 \dots s_l} = \mathcal{O}(\varepsilon^m)$, $\tilde{h}_{q,s_1 \dots s_l}^M = \mathcal{O}(\varepsilon^k)$, $m, k \geq 0$.

Proof. We obtain this result by induction. Taking $q = l = 0$ in (3.2.16) we get $M_{0,\emptyset} = \varepsilon^2 \tilde{M}_{0,\emptyset}$, $h_{0,\emptyset}^M = -\varepsilon^2 I_3$, with $\tilde{M}_{0,\emptyset} = \mathcal{O}(1)$; hence, the previous assertion holds for $q + l = 0$.

We suppose that $\forall q, l$ with $q + l < p$ the assertion of the proposition is true and we prove it for $q + l = p$. This result is obtained directly from (3.2.16), by using the property for all the terms containing a matrix $M_{k,j}$ with $k + j < p$. \square

To determine the asymptotic solution it remains to obtain the functions $\mathbf{w}_k, \mathbf{v}_k, p_k$. For this purpose we define the new function

$$\begin{aligned} \bar{\mathbf{w}}_\varepsilon^{(J)}(\bar{x}, t) &= \varepsilon^{-1} \left(\mathbf{w}_\varepsilon^{(J)}(\bar{x}, t) \cdot \mathbf{e}_1 \right) \mathbf{e}_1 \\ &+ \varepsilon^{-1} \left(\mathbf{w}_\varepsilon^{(J)}(\bar{x}, t) \cdot \mathbf{e}_2 \right) \mathbf{e}_2 + \left(\mathbf{w}_\varepsilon^{(J)}(\bar{x}, t) \cdot \mathbf{e}_3 \right) \mathbf{e}_3 \end{aligned} \quad (3.2.17)$$

and we introduce the notations

$$\begin{cases} \hat{E}_1 = \left\langle \frac{E}{1-\nu^2} \right\rangle, \hat{E}_2 = \left\langle \frac{E}{2(1+\nu)} \right\rangle, \hat{E}_3 = \left\langle \frac{E}{2(1-\nu)} \right\rangle, \\ \hat{\hat{E}}_1 = \left\langle \frac{E}{1-\nu^2} \left(\frac{1}{2} - \xi_3 \right) \right\rangle, \hat{\hat{E}}_2 = \left\langle \frac{E}{1-\nu^2} \right\rangle, \\ \hat{J} = \left\langle \left(\frac{E}{1-\nu^2} \left(\frac{1}{2} - \xi_3 \right) \right) \right\rangle. \end{cases} \quad (3.2.18)$$

Using the expressions previously obtained for $h_{q, s_1 \dots s_l}^N$, $q+l \leq 4$, applying Proposition 3.1 for $h_{q, s_1 \dots s_l}^M$, replacing $\mathbf{w}_\varepsilon^{(J)}$ by the new function defined in (3.2.17) and using (3.2.18)

$$\begin{aligned} (P_\varepsilon \mathbf{u}_\varepsilon^{(J)})_1 &= -\varepsilon^{-2} \left\{ \hat{E}_1 \frac{\partial^2 (\bar{w}_\varepsilon^{(J)})_1}{\partial x_1^2} + \hat{E}_3 \frac{\partial^2 (\bar{w}_\varepsilon^{(J)})_2}{\partial x_1 \partial x_2} + \hat{E}_2 \frac{\partial^2 (\bar{w}_\varepsilon^{(J)})_1}{\partial x_2^2} \right. \\ &\quad \left. + \hat{\hat{E}}_1 \frac{\partial}{\partial x_1} \left(\Delta (w_\varepsilon^{(J)})_3 \right) \right\} + \mathbf{R}_\varepsilon^{(J)} \cdot \mathbf{e}_1, \\ (P_\varepsilon \mathbf{u}_\varepsilon^{(J)})_2 &= -\varepsilon^{-2} \left\{ \hat{E}_2 \frac{\partial^2 (\bar{w}_\varepsilon^{(J)})_2}{\partial x_1^2} + \hat{E}_3 \frac{\partial^2 (\bar{w}_\varepsilon^{(J)})_1}{\partial x_1 \partial x_2} + \hat{E}_1 \frac{\partial^2 (\bar{w}_\varepsilon^{(J)})_2}{\partial x_2^2} \right. \\ &\quad \left. + \hat{\hat{E}}_1 \frac{\partial}{\partial x_2} \left(\Delta (w_\varepsilon^{(J)})_3 \right) \right\} + \mathbf{R}_\varepsilon^{(J)} \cdot \mathbf{e}_2, \\ (P_\varepsilon \mathbf{u}_\varepsilon^{(J)})_3 &= -\varepsilon^{-1} \left\{ \hat{\hat{E}}_2 \left(\frac{\partial}{\partial x_1} \left(\Delta (\bar{w}_\varepsilon^{(J)})_1 \right) + \frac{\partial}{\partial x_2} \left(\Delta (\bar{w}_\varepsilon^{(J)})_2 \right) \right) \right. \\ &\quad \left. + \hat{J} \Delta \left(\Delta (w_\varepsilon^{(J)})_3 \right) - \left(\boldsymbol{\psi}_\varepsilon^{(J)} \right)_3 \right\} + \mathbf{R}_\varepsilon^{(J)} \cdot \mathbf{e}_3, \end{aligned} \quad (3.2.19)$$

where the three components of $\mathbf{R}_\varepsilon^{(J)}$ are

$$\begin{aligned}
\mathbf{R}_\varepsilon^{(J)} \mathbf{e}_1 &= \varepsilon^{-1} (\boldsymbol{\psi}_\varepsilon^{(J)})_1 + \varepsilon^0 \left(- (h_{0,1111}^N)_{11} \frac{\partial^4 (\bar{w}_\varepsilon^{(J)})_1}{\partial x_1^4} - (h_{0,3,1}^N)_{12} \frac{\partial^4 (\bar{w}_\varepsilon^{(J)})_2}{\partial x_1^3 \partial x_2} \right. \\
&\quad - (h_{0,2,2}^N)_{11} \frac{\partial^4 (\bar{w}_\varepsilon^{(J)})_1}{\partial x_1^2 \partial x_2^2} - (h_{0,1,3}^N)_{12} \frac{\partial^4 (\bar{w}_\varepsilon^{(J)})_2}{\partial x_1 \partial x_2^3} - (h_{0,2222}^N)_{11} \frac{\partial^4 (\bar{w}_\varepsilon^{(J)})_1}{\partial x_2^4} \Big) \\
&\quad + \varepsilon \left(\langle \rho_+ \rangle \frac{\partial^2 (\bar{w}_\varepsilon^{(J)})_1}{\partial t^2} + \left\langle \bar{\rho}_+ \frac{\nu}{1-\nu} + \rho_+ \left(\frac{1}{2} - \xi_3 \right) \right\rangle \frac{\partial^3 (w_\varepsilon^{(J)})_3}{\partial t^2 \partial x_1} \right) \\
&\quad + \varepsilon^3 \left(\sum_{i_1=1}^2 (\tilde{h}_{2,s_1 s_1}^N)_{11} \frac{\partial^4 (\bar{w}_\varepsilon^{(J)})_1}{\partial t^2 \partial x_{s_1}^2} + (\tilde{h}_{2,1,1}^N)_{12} \frac{\partial^4 (\bar{w}_\varepsilon^{(J)})_2}{\partial t^2 \partial x_1 \partial x_2} \right) + \varepsilon^6 (\tilde{h}_{4,\emptyset}^N)_{11} \frac{\partial^4 (\bar{w}_\varepsilon^{(J)})_1}{\partial t^4} \\
&\quad - \sum_{q+l=5}^J \varepsilon^{q+l-5} \sum_{s:|s|=l} \left(h_{q,s_1 \dots s_l}^N \frac{\partial^{q+l} \left(\varepsilon (\bar{w}_\varepsilon^{(J)})_1 \mathbf{e}_1 + \varepsilon (\bar{w}_\varepsilon^{(J)})_2 \mathbf{e}_2 + (w_\varepsilon^{(J)})_3 \mathbf{e}_3 \right)}{\partial t^q \partial x_{s_1} \dots \partial x_{s_l}} \right)_1 \\
&\quad - \sum_{q+l=1}^J \varepsilon^{q+l-1} \sum_{s:|s|=l} \left(\tilde{h}_{q,s_1 \dots s_l}^M \frac{\partial^{q+l} \boldsymbol{\psi}_\varepsilon^{(J)}}{\partial t^q \partial x_{s_1} \dots \partial x_{s_l}} \right)_1 + \mathbf{r}_\varepsilon^{(J),1} \cdot \mathbf{e}_1,
\end{aligned}$$

$$\begin{aligned}
\mathbf{R}_\varepsilon^{(J)} \mathbf{e}_2 &= \varepsilon^{-1} (\boldsymbol{\psi}_\varepsilon^{(J)})_2 + \varepsilon^0 \left(- (h_{0,1111}^N)_{22} \frac{\partial^4 (\bar{w}_\varepsilon^{(J)})_2}{\partial x_1^4} - (h_{0,3,1}^N)_{21} \frac{\partial^4 (\bar{w}_\varepsilon^{(J)})_1}{\partial x_1^3 \partial x_2} \right. \\
&\quad - (h_{0,2,2}^N)_{22} \frac{\partial^4 (\bar{w}_\varepsilon^{(J)})_2}{\partial x_1^2 \partial x_2^2} - (h_{0,1,3}^N)_{21} \frac{\partial^4 (\bar{w}_\varepsilon^{(J)})_1}{\partial x_1 \partial x_2^3} - (h_{0,2222}^N)_{22} \frac{\partial^4 (\bar{w}_\varepsilon^{(J)})_2}{\partial x_2^4} \Big) \\
&\quad + \varepsilon \left(\langle \rho_+ \rangle \frac{\partial^2 (\bar{w}_\varepsilon^{(J)})_2}{\partial t^2} + \left\langle \bar{\rho}_+ \frac{\nu}{1-\nu} + \rho_+ \left(\frac{1}{2} - \xi_3 \right) \right\rangle \frac{\partial^3 (w_\varepsilon^{(J)})_3}{\partial t^2 \partial x_2} \right) \\
&\quad + \varepsilon^3 \left(\sum_{i_1=1}^2 (\tilde{h}_{2,s_1 s_1}^N)_{22} \frac{\partial^4 (\bar{w}_\varepsilon^{(J)})_2}{\partial t^2 \partial x_{s_1}^2} + (\tilde{h}_{2,1,1}^N)_{21} \frac{\partial^4 (\bar{w}_\varepsilon^{(J)})_1}{\partial t^2 \partial x_1 \partial x_2} \right) + \varepsilon^6 (\tilde{h}_{4,\emptyset}^N)_{22} \frac{\partial^4 (\bar{w}_\varepsilon^{(J)})_2}{\partial t^4} \\
&\quad - \sum_{q+l=5}^J \varepsilon^{q+l-5} \sum_{s:|s|=l} \left(h_{q,s_1 \dots s_l}^N \frac{\partial^{q+l} \left(\varepsilon (\bar{w}_\varepsilon^{(J)})_1 \mathbf{e}_1 + \varepsilon (\bar{w}_\varepsilon^{(J)})_2 \mathbf{e}_2 + (w_\varepsilon^{(J)})_3 \mathbf{e}_3 \right)}{\partial t^q \partial x_{s_1} \dots \partial x_{s_l}} \right)_2 \\
&\quad - \sum_{q+l=1}^J \varepsilon^{q+l-1} \sum_{s:|s|=l} \left(\tilde{h}_{q,s_1 \dots s_l}^M \frac{\partial^{q+l} \boldsymbol{\psi}_\varepsilon^{(J)}}{\partial t^q \partial x_{s_1} \dots \partial x_{s_l}} \right)_2 + \mathbf{r}_\varepsilon^{(J),1} \cdot \mathbf{e}_2,
\end{aligned}$$

(3.2.20)

$$\begin{aligned}
\mathbf{R}_\varepsilon^{(J)} \mathbf{e}_3 &= \varepsilon^0 \langle \rho_+ \rangle \frac{\partial^2 (w_\varepsilon^{(J)})_3}{\partial t^2} \\
&+ \varepsilon^2 \left(\sum_{j=1}^2 \left\langle \bar{\rho}_+ + \rho_+ \frac{\nu}{1-\nu} \right\rangle \frac{\partial^3 (\bar{w}_\varepsilon^{(J)})_j}{\partial t^2 \partial x_j} + \sum_{i_1=1}^2 (\tilde{h}_{2, s_1 s_1}^N)_{33} \frac{\partial^4 (w_\varepsilon^{(J)})_3}{\partial t^2 \partial x_{s_1}^2} \right) \\
&+ \varepsilon^5 (\tilde{h}_{4, \emptyset}^N)_{33} \frac{\partial^4 (w_\varepsilon^{(J)})_3}{\partial t^4} \\
&- \sum_{q+l=5}^J \varepsilon^{q+l-5} \sum_{s:|s|=l} \left(h_{q, s_1 \dots s_l}^N \frac{\partial^{q+l} \left(\varepsilon (\bar{w}_\varepsilon^{(J)})_1 \mathbf{e}_1 + \varepsilon (\bar{w}_\varepsilon^{(J)})_2 \mathbf{e}_2 + (w_\varepsilon^{(J)})_3 \mathbf{e}_3 \right)}{\partial t^q \partial x_{s_1} \dots \partial x_{s_l}} \right)_3 \\
&- \sum_{q+l=1}^J \varepsilon^{q+l-1} \sum_{s:|s|=l} \left(\tilde{h}_{q, s_1 \dots s_l}^M \frac{\partial^{q+l} \psi_\varepsilon^{(J)}}{\partial t^q \partial x_{s_1} \dots \partial x_{s_l}} \right)_3 + \mathbf{r}_\varepsilon^{(J),1} \cdot \mathbf{e}_3.
\end{aligned}$$

with $h_{q, s_1 \dots s_l}^{N,M} = \varepsilon^2 \tilde{h}_{q, s_1 \dots s_l}^{N,M}$.

We consider

$$\bar{\mathbf{w}}_\varepsilon^{(J)} = \sum_{k=-1}^J \varepsilon^k \bar{\mathbf{w}}_k(\bar{x}, t), \quad (3.2.21)$$

so that, together with (3.2.17) and (3.2.1)₅, it gives

$$\begin{cases} (w_k)_1 = (\bar{w}_{k-1})_1, \\ (w_k)_2 = (\bar{w}_{k-1})_2, \\ (w_k)_3 = (\bar{w}_k)_3 \quad \forall k \geq 0. \end{cases} \quad (3.2.22)$$

Analyzing the order of the terms of (3.2) we can write

$$\begin{cases} \mathbf{R}_\varepsilon^{(J)} \cdot \mathbf{e}_1 - \mathbf{r}_\varepsilon^{(J),1} \cdot \mathbf{e}_1 = \sum_{k=0}^{J+r_1} \varepsilon^{k-1} \mathbf{R}_k \cdot \mathbf{e}_1, \\ \mathbf{R}_\varepsilon^{(J)} \cdot \mathbf{e}_2 - \mathbf{r}_\varepsilon^{(J),1} \cdot \mathbf{e}_2 = \sum_{k=0}^{J+r_2} \varepsilon^{k-1} \mathbf{R}_k \cdot \mathbf{e}_2, \\ \mathbf{R}_\varepsilon^{(J)} \cdot \mathbf{e}_3 - \mathbf{r}_\varepsilon^{(J),1} \cdot \mathbf{e}_3 = \sum_{k=0}^{J+r_3} \varepsilon^k \mathbf{R}_k \cdot \mathbf{e}_3, \end{cases} \quad (3.2.23)$$

with $r_1, r_2, r_3 > 0$ and \mathbf{R}_k independent of ξ_3 and bounded by a constant independent of ε . In order to obtain the expressions of $\mathbf{R}_k \cdot \mathbf{e}_1$, $\mathbf{R}_k \cdot \mathbf{e}_2$ and $\mathbf{R}_k \cdot \mathbf{e}_3$ necessary in what follows, we establish the following result:

Lemma 3.2. a) For any $q \in \mathbb{N}^*$ the matrices $h_{q,\emptyset}^N$, $N_{q,\emptyset}$ have the form

$$h_{q,\emptyset}^N = \begin{pmatrix} \alpha_q & 0 & 0 \\ 0 & \beta_q & 0 \\ 0 & 0 & \gamma_q \end{pmatrix}, \quad N_{q,\emptyset}(\xi_3) = \begin{pmatrix} \sigma_q(\xi_3) & 0 & 0 \\ 0 & \delta_q(\xi_3) & 0 \\ 0 & 0 & \varphi_q(\xi_3) \end{pmatrix}. \quad (3.2.24)$$

The same result holds for $h_{q,\emptyset}^M$, $M_{q,\emptyset}$, with the elements denoted by $\alpha_q^M, \beta_q^M, \gamma_q^M$ and $\sigma_q^M, \delta_q^M, \varphi_q^M$, respectively.

b) For any $q, j_{1,2} \in \mathbb{N}^*$ we have

$$\begin{aligned} h_{q,r,p}^N &= \begin{pmatrix} \alpha_{q,r,p} & 0 & 0 \\ 0 & \beta_{q,r,p} & 0 \\ 0 & 0 & \gamma_{q,r,p} \end{pmatrix}, \quad \text{if } r = 2j_1, p = 2j_2, \\ h_{q,r,p}^N &= \begin{pmatrix} 0 & 0 & 0 \\ 0 & 0 & \beta_{q,2j_1,2j_2+1} \\ 0 & \gamma_{q,2j_1,2j_2+1} & 0 \end{pmatrix}, \quad \text{if } r = 2j_1, p = 2j_2 + 1, \\ h_{q,r,p}^N &= \begin{pmatrix} 0 & 0 & \alpha_{q,2j_1+1,2j_2} \\ 0 & 0 & 0 \\ \gamma_{q,2j_1+1,2j_2} & 0 & 0 \end{pmatrix}, \quad \text{if } r = 2j_1 + 1, p = 2j_2, \\ h_{q,r,p}^N &= \begin{pmatrix} 0 & \alpha_{q,2j_1+1,2j_2+1} & 0 \\ \beta_{q,2j_1+1,2j_2+1} & 0 & 0 \\ 0 & 0 & 0 \end{pmatrix}, \quad \text{if } r = 2j_1 + 1, p = 2j_2 + 1 \end{aligned} \quad (3.2.25)$$

and the matrices $N_{q,r,p}, h_{q,r,p}^M, M_{q,r,p}$ have the same form as $h_{q,r,p}^N$, where

$$h_{q,r,p}^{N,M} = \sum_{\substack{s:|s|=r+p, \\ |\{s_j=1\}|=r, \\ |\{s_j=2\}|=p}} h_{q,s_1\dots s_{r+p}}^{N,M}.$$

Proof. The result is obtained by induction using the relations of (3.2.14) for $h_{q,s_1\dots s_l}^N, N_{q,s_1\dots s_l}$ and the relations of (3.2.16) for $h_{q,s_1\dots s_l}^M, M_{q,s_1\dots s_l}$. \square

Denoting by

$$\psi_k(\bar{x}, t) = 2\tilde{\nu}D(\mathbf{v}_k(\bar{x}, 0, t))\mathbf{e}_3 - p_k(\bar{x}, 0, t)\mathbf{e}_3 \quad (3.2.26)$$

and using (3.2), (3.2.23) and (3.2.24) we obtain for any $k \geq 0$

$$\begin{aligned}
\mathbf{R}_k \cdot \mathbf{e}_1 &= (\psi_k)_1 + \langle \rho_+ \rangle \frac{\partial^2(\bar{w}_{k-2})_1}{\partial t^2} + (\tilde{h}_{4,\emptyset}^N)_{11} \frac{\partial^4(\bar{w}_{k-7})_1}{\partial t^4} \\
&\quad - \sum_{q=5}^J \alpha_q \frac{\partial^q(\bar{w}_{k+3-q})_1}{\partial t^q} - \sum_{q=1}^J \alpha_q^M \frac{\partial^q(\psi_{k-q})_1}{\partial t^q} + \tilde{\mathbf{R}}_k \cdot \mathbf{e}_1, \\
\mathbf{R}_k \cdot \mathbf{e}_2 &= (\psi_k)_2 + \langle \rho_+ \rangle \frac{\partial^2(\bar{w}_{k-2})_2}{\partial t^2} + (\tilde{h}_{4,\emptyset}^N)_{22} \frac{\partial^4(\bar{w}_{k-7})_2}{\partial t^4} \\
&\quad - \sum_{q=5}^J \beta_q \frac{\partial^q(\bar{w}_{k+3-q})_2}{\partial t^q} - \sum_{q=1}^J \beta_q^M \frac{\partial^q(\psi_{k-q})_2}{\partial t^q} + \tilde{\mathbf{R}}_k \cdot \mathbf{e}_2, \\
\mathbf{R}_k \cdot \mathbf{e}_3 &= \langle \rho_+ \rangle \frac{\partial^2(w_k)_3}{\partial t^2} + (\tilde{h}_{4,\emptyset}^N)_{33} \frac{\partial^4(w_{k-5})_3}{\partial t^4} \\
&\quad - \sum_{q=5}^J \gamma_q \frac{\partial^q(w_{k+5-q})_3}{\partial t^q} - \sum_{q=1}^J \gamma_q^M \frac{\partial^q(\psi_{k-q+1})_3}{\partial t^q} + \tilde{\mathbf{R}}_k \cdot \mathbf{e}_3,
\end{aligned} \tag{3.2.27}$$

where $\tilde{\mathbf{R}}_k$ are functions defined by $(\bar{w}_{k''})_1$, $(\bar{w}_{k''})_2$, $(w_{k'})_3$, $\mathbf{v}_{k'}$, $p_{k'}$, with $k'' \leq k-2$, $k' \leq k-1$ and they have the mean value with respect to x_1, x_2 equal to zero.

Introducing expansions (3.2.21), (3.2.23) and (3.2.1)_{4,2,3} in (3.2.19), neglecting the residuals, using (2.1.1)₁ and collecting together the terms of the same order with respect to the small parameter ε we obtain

$$\left\{ \begin{aligned}
& -\hat{E}_1 \frac{\partial^2(\bar{w}_k)_1}{\partial x_1^2} - \hat{E}_3 \frac{\partial^2(\bar{w}_k)_2}{\partial x_1 \partial x_2} - \hat{E}_2 \frac{\partial^2(\bar{w}_k)_1}{\partial x_2^2} - \hat{E}_1 \left(\frac{\partial^3(w_k)_3}{\partial x_1^3} + \frac{\partial^3(w_k)_3}{\partial x_1 \partial x_2^2} \right) \\
& \quad = g_1 \delta_{k1} - \mathbf{R}_{k-1} \cdot \mathbf{e}_1, \\
& -\hat{E}_2 \frac{\partial^2(\bar{w}_k)_2}{\partial x_1^2} - \hat{E}_3 \frac{\partial^2(\bar{w}_k)_1}{\partial x_1 \partial x_2} - \hat{E}_1 \frac{\partial^2(\bar{w}_k)_2}{\partial x_2^2} - \hat{E}_1 \left(\frac{\partial^3(w_k)_3}{\partial x_1^2 \partial x_2} + \frac{\partial^3(w_k)_3}{\partial x_2^3} \right) \\
& \quad = g_2 \delta_{k1} - \mathbf{R}_{k-1} \cdot \mathbf{e}_2, \\
& -\hat{E}_2 \left(\frac{\partial^3(\bar{w}_k)_1}{\partial x_1^3} + \frac{\partial^3(\bar{w}_k)_2}{\partial x_1^2 \partial x_2} + \frac{\partial^3(\bar{w}_k)_1}{\partial x_1 \partial x_2^2} + \frac{\partial^3(\bar{w}_k)_2}{\partial x_2^3} \right) - \hat{J} \left(\frac{\partial^4(w_k)_3}{\partial x_1^4} + \frac{\partial^4(w_k)_3}{\partial x_1^2 \partial x_2^2} \right. \\
& \quad \left. + \frac{\partial^4(w_k)_3}{\partial x_2^4} \right) + \left(2\tilde{\nu} \frac{\partial(v_k)_3}{\partial x_3} - p_k \right) \Big|_{x_3=0} = g_3 \delta_{k0} - \mathbf{R}_{k-1} \cdot \mathbf{e}_3.
\end{aligned} \right. \tag{3.2.28}$$

Computing $-\hat{E}_2 \cdot \left(\frac{\partial}{\partial x_1} (3.2.28)_1 + \frac{\partial}{\partial x_2} (3.2.28)_2 \right) + \hat{E}_1 \cdot (3.2.28)_3$ we get

$$\begin{aligned} & \hat{E}_1^{-1} (\hat{E}_1 \cdot \hat{E}_2 - \hat{E}_1 \cdot \hat{J}) \Delta(\Delta(w_k)_3) + \left(2\tilde{\nu} \frac{\partial (v_k)_3}{\partial x_3} - p_k \right) \Big|_{x_3=0} \\ &= g_3 \delta_{k0} - \mathbf{R}_{k-1} \cdot \mathbf{e}_3 - \hat{E}_1^{-1} \cdot \hat{E}_2 \left(\frac{\partial g_1}{\partial x_1} \delta_{k1} - \frac{\partial \mathbf{R}_{k-1}}{\partial x_1} \cdot \mathbf{e}_1 + \frac{\partial g_2}{\partial x_2} \delta_{k1} - \frac{\partial \mathbf{R}_{k-1}}{\partial x_2} \cdot \mathbf{e}_2 \right). \end{aligned} \quad (3.2.29)$$

We introduce the notation

$$\hat{J} = \hat{E}_1^{-1} (\hat{E}_1 \cdot \hat{E}_2 - \hat{E}_1 \cdot \hat{J}) \quad (3.2.30)$$

and prove that

Proposition 3.3. *The constant \hat{J} is strictly positive.*

Proof. Let us denote $a(s) = \frac{E(s)}{1 - \nu^2(s)}$. Using this notation, (3.2.18) obviously gives

$$\begin{aligned} \hat{E}_1 &= \langle a \rangle, \quad \hat{E}_1^{-1} = \frac{1}{2} \langle a \rangle - \langle sa \rangle, \quad \hat{E}_2 = \frac{1}{2} \langle a \rangle - \left\langle \int_0^\theta a(s) ds \right\rangle, \\ \hat{J} &= \frac{1}{4} \langle a \rangle - \frac{1}{2} \langle sa \rangle - \frac{1}{2} \left\langle \int_0^\theta a(s) ds \right\rangle + \left\langle \int_0^\theta sa(s) ds \right\rangle. \end{aligned}$$

Hence $\hat{E}_1 \cdot \hat{E}_2 - \hat{E}_1 \cdot \hat{J} = \langle sa \rangle \left\langle \int_0^\theta a(s) ds \right\rangle - \langle a \rangle \left\langle \int_0^\theta sa(s) ds \right\rangle$. We define the function $F : [0, 1] \mapsto \mathbb{R}$, $F(\tau) = \left(\int_0^\tau s a(s) ds \right) \left(\int_0^\tau \left(\int_0^\theta a(s) ds \right) d\theta \right) - \left(\int_0^\tau a(s) ds \right) \left(\int_0^\tau \left(\int_0^\theta s a(s) ds \right) d\theta \right)$. It is obvious that $F(0) = 0$ and $F(1) = \hat{E}_1 \cdot \hat{E}_2 - \hat{E}_1 \cdot \hat{J}$; moreover,

$$F'(\tau) = a(\tau) \left(\tau \int_0^\tau \left(\int_0^\theta a(s) ds \right) d\theta - \int_0^\tau \left(\int_0^\theta s a(s) ds \right) d\theta \right) \geq 0,$$

and it is > 0 for $\tau > 0$. From these properties we obtain the assertion of the proposition. \square

Introducing next expansions (3.2.1)_{2,3} in (2.1.1)_{2,3,5} we obtain (without residual)

$$\begin{cases} \rho_- \frac{\partial \mathbf{v}_k}{\partial t} - 2\tilde{\nu} \operatorname{div}(D(\mathbf{v}_k)) + \nabla p_k = \mathbf{f} \delta_{k0}, \\ \operatorname{div} \mathbf{v}_k = 0 \\ \mathbf{v}_k(\bar{x}, -1, t) = \mathbf{0}. \end{cases} \quad \text{in } D^- \times (0, T), \quad (3.2.31)$$

It remains to analyze junction condition (2.1.1)₆. Introducing expansions (3.2.2)_{1,2} in (2.1.1)₆ one can see that

$$\begin{aligned} \mathbf{v}_\varepsilon^{(J)}(\bar{x}, 0, t) - \frac{\partial \mathbf{u}_\varepsilon^{(J)}}{\partial t}(\bar{x}, 0, t) &= \sum_{k=0}^J \varepsilon^k \left(\mathbf{v}_k(\bar{x}, 0, t) \right. \\ &\left. - \sum_{q+l=0}^J \sum_{s:|s|=l} N_{q, s_1 \dots s_l}(0) \frac{\partial^{q+l+1} \mathbf{w}_{k-(q+l)}(\bar{x}, t)}{\partial t^{q+1} \partial x_{s_1} \dots \partial x_{s_l}} \right) - \mathbf{r}_\varepsilon^{(J),6}(\bar{x}, t), \end{aligned} \quad (3.2.32)$$

where

$$\mathbf{r}_\varepsilon^{(J),6}(\bar{x}, t) = \sum_{k=J+1}^{J+q+l} \varepsilon^k \left(\sum_{q+l=1}^J \sum_{s:|s|=l} N_{q, s_1 \dots s_l}(0) \frac{\partial^{q+l+1} \mathbf{w}_{k-(q+l)}(\bar{x}, t)}{\partial t^{q+1} \partial x_{s_1} \dots \partial x_{s_l}} \right). \quad (3.2.33)$$

So,

$$\mathbf{v}_k(\bar{x}, 0, t) = \frac{\partial}{\partial t} \left((\bar{w}_{k-1})_1 \mathbf{e}_1 + (\bar{w}_{k-1})_2 \mathbf{e}_2 + (w_k)_3 \mathbf{e}_3 \right) (\bar{x}, t) + \boldsymbol{\alpha}_{k-1}(\bar{x}, t), \quad (3.2.34)$$

with

$$\begin{aligned} \boldsymbol{\alpha}_{k-1}(\bar{x}, t) &= \sum_{q+l=1}^J \sum_{s:|s|=l} N_{q, s_1 \dots s_l}(0) \\ &\cdot \frac{\partial^{q+l+1} \left((\bar{w}_{k-(q+l)-1})_1 \mathbf{e}_1 + (\bar{w}_{k-(q+l)-1})_2 \mathbf{e}_2 + (w_{k-(q+l)})_3 \mathbf{e}_3 \right)}{\partial t^{q+1} \partial x_{s_1} \dots \partial x_{s_l}}, \end{aligned} \quad (3.2.35)$$

where $\boldsymbol{\alpha}_{k-1}$ contains only $(\bar{w}_{k'-1})_1$, $(\bar{w}_{k'-1})_2$ and $(w_{k'})_3$, with $k' \leq k-1$.

In addition to the previous relations, we consider the periodicity, the initial conditions and the property

$$\langle (w_k)_3 \rangle = 0, \quad \forall k \geq 0. \quad (3.2.36)$$

In this way, for every $k \geq -1$ we obtain the following two problems:

$$\left\{ \begin{array}{l} \hat{J} \Delta_{\bar{x}}^2 (w_k)_3 + \left(2\tilde{\nu} \frac{\partial (v_k)_3}{\partial x_3} - p_k \right) \Big|_{x_3=0} = g_3 \delta_{k0} - \mathbf{R}_{k-1} \cdot \mathbf{e}_3 \\ - \hat{E}_1^{-1} \cdot \hat{E}_2 \left(\frac{\partial g_1}{\partial x_1} \delta_{k1} - \frac{\partial \mathbf{R}_{k-1}}{\partial x_1} \cdot \mathbf{e}_1 + \frac{\partial g_2}{\partial x_2} \delta_{k1} - \frac{\partial \mathbf{R}_{k-1}}{\partial x_2} \cdot \mathbf{e}_2 \right) \text{ in } D \times (0, T), \\ \rho_- \frac{\partial \mathbf{v}_k}{\partial t} - 2\tilde{\nu} \operatorname{div}(D(\mathbf{v}_k)) + \nabla p_k = \mathbf{f} \delta_{k0}, \\ \operatorname{div} \mathbf{v}_k = 0 \quad \text{in } D^- \times (0, T), \\ \mathbf{v}_k(\bar{x}, -1, t) = \mathbf{0} \quad \text{in } D \times (0, T), \\ (v_k)_1(\bar{x}, 0, t) = \frac{\partial((\bar{w}_{k-1})_1)}{\partial t}(\bar{x}, t) + \boldsymbol{\alpha}_{k-1} \cdot \mathbf{e}_1 \quad \text{in } D \times (0, T), \\ (v_k)_2(\bar{x}, 0, t) = \frac{\partial((\bar{w}_{k-1})_2)}{\partial t}(\bar{x}, t) + \boldsymbol{\alpha}_{k-1} \cdot \mathbf{e}_2 \quad \text{in } D \times (0, T), \\ (v_k)_3(\bar{x}, 0, t) = \frac{\partial(w_k)_3}{\partial t}(\bar{x}, t) + \boldsymbol{\alpha}_{k-1} \cdot \mathbf{e}_3 \quad \text{in } D \times (0, T), \\ (w_k)_3, \mathbf{v}_k, p_k \text{ } D\text{-periodic,} \\ \mathbf{v}_k(x, 0) = \mathbf{0} \quad \text{in } D^-, \\ (w_k)_3(\bar{x}, 0) = 0 \quad \text{in } D, \quad k \geq 0 \end{array} \right. \quad (3.2.37)$$

and

$$\left\{ \begin{array}{l} \hat{E}_1 \frac{\partial^2 (\bar{w}_k)_1}{\partial x_1^2} + \hat{E}_3 \frac{\partial^2 (\bar{w}_k)_2}{\partial x_1 \partial x_2} + \hat{E}_2 \frac{\partial^2 (\bar{w}_k)_1}{\partial x_2^2} = -(y_k)_1, \\ \hat{E}_2 \frac{\partial^2 (\bar{w}_k)_2}{\partial x_1^2} + \hat{E}_3 \frac{\partial^2 (\bar{w}_k)_1}{\partial x_1 \partial x_2} + \hat{E}_1 \frac{\partial^2 (\bar{w}_k)_2}{\partial x_2^2} = -(y_k)_2, \\ \mathbf{y}_k = \hat{E}_1 \nabla_{\bar{x}} (\Delta_{\bar{x}} (w_k)_3) + \mathbf{g} \delta_{k1} - \mathbf{R}_{k-1}, \\ \bar{\mathbf{w}}_k \text{ } D\text{-periodic, } k \geq -1, \end{array} \right. \quad (3.2.38)$$

where the terms \mathbf{R}_{k-1} , $\boldsymbol{\alpha}_{k-1}$ depend on the functions $(\bar{w}_{k'-1})_1$, $(\bar{w}_{k'-1})_2$, $(w_{k'})_3$, $\mathbf{v}_{k'}$, $p_{k'}$ and their derivatives, with $k' \leq k-1$. From the smoothness and periodicity properties of the functions $(\bar{w}_k)_1$, $(\bar{w}_k)_2$ and $(w_k)_3$, it follows that problem (3.2.38) has a solution if and only if the following solvability condition is satisfied:

$$\langle \mathbf{R}_{k-1} \rangle \cdot \mathbf{e}_1 = \langle g_1 \rangle \delta_{k,1}, \quad \langle \mathbf{R}_{k-1} \rangle \cdot \mathbf{e}_2 = \langle g_2 \rangle \delta_{k,1} \quad \forall k \geq 0. \quad (3.2.39)$$

Denote by

$$\mathbf{c}_k(t) = \langle \bar{\mathbf{w}}_k \rangle \quad \forall k \geq -1, \quad (3.2.40)$$

and put

$$\hat{\mathbf{w}}_k = \bar{\mathbf{w}}_k - \mathbf{c}_k(t), \quad \langle \hat{\mathbf{w}}_k \rangle = 0, \quad k \geq -1. \quad (3.2.41)$$

Then from (3.2.38), (3.2.40), (3.2.41) we obtain for $\hat{\mathbf{w}}_k$ the following problem:

$$\begin{cases} \hat{E}_1 \frac{\partial^2(\hat{w}_k)_1}{\partial x_1^2} + \hat{E}_3 \frac{\partial^2(\hat{w}_k)_2}{\partial x_1 \partial x_2} + \hat{E}_2 \frac{\partial^2(\hat{w}_k)_1}{\partial x_2^2} = -(y_k)_1, \\ \hat{E}_2 \frac{\partial^2(\hat{w}_k)_2}{\partial x_1^2} + \hat{E}_3 \frac{\partial^2(\hat{w}_k)_1}{\partial x_1 \partial x_2} + \hat{E}_1 \frac{\partial^2(\hat{w}_k)_2}{\partial x_2^2} = -(y_k)_2, \\ \hat{\mathbf{w}}_k \text{ } D\text{-periodic, } k \geq -1, \end{cases} \quad (3.2.42)$$

where \mathbf{y}_k is defined by (3.2.38)₃.

The main result of this section consists in the construction of some smooth functions $(w_k)_3, \mathbf{v}_k, p_k, c_{k-1}$ that satisfy (3.2.37) and

$$\langle \mathbf{R}_k \rangle \cdot \mathbf{e}_1 = \langle g_1 \rangle \delta_{k,0}, \quad \langle \mathbf{R}_k \rangle \cdot \mathbf{e}_2 = \langle g_2 \rangle \delta_{k,0} \quad \forall k \geq 0. \quad (3.2.39')$$

This result is obtained below.

Theorem 3.4. *For any $k \geq 0$ there exist a triplet of functions $((w_k)_3, \mathbf{v}_k, p_k)$ and a function depending only on t , c_{k-1} , which satisfy problems (3.2.37) and (3.2.39'). Moreover, the regularity of these functions is given by $(w_k)_3 \in C^\infty([0, T]; C^\infty_{\#}(\bar{D}))$, $\mathbf{v}_k \in C^\infty([0, T]; (C^\infty_{\#}(\bar{D}) \cap H^2(D^-))^3)$, $p_k \in C^\infty([0, T]; C^\infty_{\#}(\bar{D}) \cap H^1(D^-))$ and $c_{k-1} \in C^\infty([0, T])$.*

Proof. The proof of the announced result is technical and will be obtained recursively, in several steps.

Step 1. This step is devoted to the presentation of two auxiliary problems. We study these problems and we determine their solutions which are used for the construction of the functions \mathbf{v}_k, c_{k-1} that solve, together with $(w_k)_3, p_k$ problems (3.2.37), (3.2.39'). The first auxiliary problem is: Find the functions $(w_k)_3, \hat{\mathbf{v}}_k, p_k,$

$k \geq 0$, which satisfy

$$\left\{ \begin{array}{l} \hat{J} \Delta_{\bar{x}}^2 (w_k)_3 + \left(2\tilde{\nu} \frac{\partial(\hat{v}_k)_3}{\partial x_3} - p_k \right) \Big|_{x_3=0} = g_3 \delta_{k0} - \mathbf{R}_{k-1} \cdot \mathbf{e}_3 \\ - \hat{E}_1^{-1} \cdot \hat{E}_2 \left(\frac{\partial g_1}{\partial x_1} \delta_{k1} - \frac{\partial \mathbf{R}_{k-1}}{\partial x_1} \cdot \mathbf{e}_1 + \frac{\partial g_2}{\partial x_2} \delta_{k1} - \frac{\partial \mathbf{R}_{k-1}}{\partial x_2} \cdot \mathbf{e}_2 \right) \text{ in } D \times (0, T), \\ \rho_- \frac{\partial \hat{\mathbf{v}}_k}{\partial t} - 2\tilde{\nu} \operatorname{div}(D(\hat{\mathbf{v}}_k)) + \nabla p_k = \mathbf{f} \delta_{k0}, \\ \operatorname{div} \hat{\mathbf{v}}_k = 0 \quad \text{in } D^- \times (0, T), \\ \hat{\mathbf{v}}_k(\bar{x}, -1, t) = \mathbf{0} \quad \text{in } D \times (0, T), \\ (\hat{v}_k)_1(\bar{x}, 0, t) = \frac{\partial((\hat{w}_{k-1})_1)}{\partial t}(\bar{x}, t) + \boldsymbol{\alpha}_{k-1} \cdot \mathbf{e}_1 \quad \text{in } D \times (0, T), \\ (\hat{v}_k)_2(\bar{x}, 0, t) = \frac{\partial((\hat{w}_{k-1})_2)}{\partial t}(\bar{x}, t) + \boldsymbol{\alpha}_{k-1} \cdot \mathbf{e}_2 \quad \text{in } D \times (0, T), \\ (\hat{v}_k)_3(\bar{x}, 0, t) = \frac{\partial(w_k)_3}{\partial t}(\bar{x}, t) + \boldsymbol{\alpha}_{k-1} \cdot \mathbf{e}_3 \quad \text{in } D \times (0, T), \\ (w_k)_3, \hat{\mathbf{v}}_k, p_k \text{ } D\text{-periodic}, \\ \hat{\mathbf{v}}_k(x, 0) = \mathbf{0} \quad \text{in } D^-, \\ (w_k)_3(\bar{x}, 0) = 0 \quad \text{in } D, \quad k \geq 0. \end{array} \right. \quad (3.2.43)$$

We give below the second auxiliary problem. For any $k \geq 0$, find $\mathbf{V}_k : [-1, 0] \times [0, T] \mapsto \mathbb{R}^2$ solution for

$$\left\{ \begin{array}{l} \rho_- \frac{\partial \mathbf{V}_k}{\partial t} - \tilde{\nu} \frac{\partial^2 \mathbf{V}_k}{\partial x_3^2} = \mathbf{0} \text{ in } (-1, 0) \times (0, T), \\ \tilde{\nu} \frac{\partial \mathbf{V}_k}{\partial x_3} = \boldsymbol{\gamma}_{k-1} \text{ on } \{x_3 = 0\} \times (0, T), \\ \mathbf{V}_k = \mathbf{0} \text{ on } \{x_3 = -1\} \times (0, T), \\ \mathbf{V}_k(0) = \mathbf{0} \text{ in } (-1, 0) \end{array} \right. \quad (3.2.44)$$

with

$$\begin{aligned} (\gamma_{k-1})_i(t) &= \langle \mathbf{g} \mathbf{e}_i \rangle \delta_{k+1,1} - \langle \rho_+ \rangle (c_{k-2}'')_i - \tilde{\nu} \left\langle \frac{\partial(\hat{v}_k)_i}{\partial x_3} \Big|_{x_3=0} \right\rangle \\ &\quad - (h_{4,0})_{11} \frac{d^4(c_{k-7})_i}{dt^4} + \sum_{q=5}^J \alpha_q \frac{d^q(c_{k+q-3})_i}{dt^q} + \sum_{q=1}^J \alpha_q^M \frac{d^q}{dt^q} \langle (\psi_{k-q})_i \rangle, \quad i = 1, 2. \end{aligned} \quad (3.2.45)$$

Notice that the right hand side of (3.2.44) contains one of the unknowns of (3.2.43); after solving (3.2.43), the right hand side of (3.2.44) becomes a known function.

We announce next the results that we shall obtain concerning (3.2.43) and (3.2.44).

Theorem 3.5. *For any $k \geq 0$ problem (3.2.43) has a unique solution $((w_k)_3, \hat{\mathbf{v}}_k, p_k)$ with the regularity $(w_k)_3 \in C^\infty([0, T]; C^\infty_{\#}(\bar{D}))$, $\hat{\mathbf{v}}_k \in C^\infty([0, T]; (H^2(D^-))^3)$, $\frac{\partial^j \hat{\mathbf{v}}_k}{\partial x_i^j} \in C^\infty([0, T]; (L^2(D^-))^3)$, $p_k \in C^\infty([0, T]; (H^2(D^-))^3)$, $\frac{\partial^j p_k}{\partial x_i^j} \in C^\infty([0, T]; L^2(D^-))$, $i = 1, 2, j \in \mathbb{N}$.*

Theorem 3.6. *For any $k \geq 0$ problem (3.2.44) has a unique solution \mathbf{V}_k with the regularity $\mathbf{V}_k \in C^\infty([0, T]; (H^3(-1, 0))^2)$.*

Step 2. This step contains the proofs of the previous two theorems for $k = 0$. We mention that, even if problems (3.2.43) and (3.2.44) are not coupled, we must solve them together since, for determining the functions of the k approximation, we need the induction assumption concerning all the functions from the previous approximations.

Proof of Theorem 3.5 for $k=0$ is given above in section 2.2.2.

Proof of Theorem 3.6 for $k=0$. For $k = 0$ (3.2.44) becomes

$$\begin{cases} \rho_- \frac{\partial \mathbf{V}_0}{\partial t} - \tilde{\nu} \frac{\partial^2 \mathbf{V}_0}{\partial x_3^2} = \mathbf{0} \text{ in } (-1, 0) \times (0, T), \\ \tilde{\nu} \frac{\partial \mathbf{V}_0}{\partial x_3} = \gamma_{-1} \text{ on } \{x_3 = 0\} \times (0, T), \\ \mathbf{V}_0 = 0 \text{ on } \{x_3 = -1\} \times (0, T), \\ \mathbf{V}_0(0) = 0 \text{ in } (-1, 0) \end{cases} \quad (3.2.46)$$

with

$$(\gamma_{-1})_i(t) = \langle \mathbf{g} \mathbf{e}_i \rangle - \tilde{\nu} \left\langle \frac{\partial(\hat{v}_0)_i}{\partial x_3} \Big|_{x_3=0} \right\rangle, \quad i = 1, 2. \quad (3.2.47)$$

This problem is known in geophysics as the heat equation with heat transfer boundary condition. We introduce the space $\tilde{H} = \{\varphi \in (H^1(-1, 0))^2 / \varphi(-1) = \mathbf{0}\}$ and by means of the variational formulation we obtain, using the Galerkin's

method, the existence of $\mathbf{V}_0 \in H^1(0, T; \tilde{H})$, the unique solution for (3.2.46). From (3.2.46)₁ it follows that $\mathbf{V}_0 \in H^1(0, T; (H^{-3}(-1, 0))^2)$; finally, the C^∞ -regularity in t is a consequence of (H2) and of the regularity of $\hat{\mathbf{v}}_0$, via (3.2.47), which achieves the proof. \square

We mention that, in addition to the properties previously obtained, all the functions determined at this step are zero for $t \in [0, \tau_0)$, due to the assumption (H3), p. 52.

Step 3. The induction assumption is that all the properties obtained in Step 2. for $k = 0$ hold for any $k', k' < k$. This step is devoted to prove these properties for k .

Proof of Theorem 3.5 for $k \geq 1$. Unlike the case $k = 0$, for $k \geq 1$ problem (3.2.43) has nonhomogeneous boundary conditions. In order to replace (3.2.43) with a homogeneous boundary problem we consider, for any $t \in [0, T]$, $k \geq 1$, the auxiliary problem

$$\begin{cases} \operatorname{div} \boldsymbol{\zeta}_k(t) = 0 & \text{in } \mathbb{R}^2 \times (-1, 0), \\ \boldsymbol{\zeta}_k(t) = \mathbf{0} & \text{on } \mathbb{R}^2 \times \{x_3 = -1\}, \\ \boldsymbol{\zeta}_k(t) = \mathbf{a}(t) & \text{on } \mathbb{R} \times \{x_3 = 0\}, \\ \boldsymbol{\zeta}_k(t) \text{ } D\text{-periodic,} \end{cases} \quad (3.2.48)$$

with $a_1(\bar{x}, t) = \frac{\partial((\hat{w}_{k-1})_1)}{\partial t}(\bar{x}, t) + \boldsymbol{\alpha}_{k-1}(\bar{x}, t) \cdot \mathbf{e}_1$, $a_2(\bar{x}, t) = \frac{\partial((\hat{w}_{k-1})_2)}{\partial t}(\bar{x}, t) + \boldsymbol{\alpha}_{k-1}(\bar{x}, t) \cdot \mathbf{e}_2$, $a_3(\bar{x}, t) = \boldsymbol{\alpha}_{k-1}(\bar{x}, t) \cdot \mathbf{e}_3$. Notice that, due to properties (3.2.24) and (3.2.36) we have $\langle \boldsymbol{\alpha}_{k-1} \rangle \cdot \mathbf{e}_3 = 0$, which represents the solvability condition for (3.2.48). We define the Fourier coefficients associated to the function \mathbf{a} as follows

$$\begin{cases} \mathbf{a}_0(t) = \langle \mathbf{a} \rangle(t), \\ \mathbf{a}_{\mathbf{m}}(t) = 2 \langle \mathbf{a} \cos 2\pi \mathbf{m} \bar{x} \rangle(t), \\ \mathbf{b}_{\mathbf{m}}(t) = 2 \langle \mathbf{a} \cos 2\pi \mathbf{m} \bar{x} \rangle(t) \end{cases} \quad |\mathbf{m}| \geq 1,$$

where $\mathbf{m} = (m_1, m_2)$ is a multi-index, $\bar{x} = (x_1, x_2)$ and $\mathbf{m}\bar{x} = m_1 x_1 + m_2 x_2$. It

can be proved by direct computation that the function

$$\begin{aligned}
\zeta_k(x, t) &= (x_3 + 1)(3x_3 + 1)(a_0)_1(t)\mathbf{e}_1 + (x_3 + 1)(3x_3 + 1)(a_0)_2(t)\mathbf{e}_2 \\
&- (x_3 + 1) \left(\sum_{m_1, m_2=1}^{\infty} \left((-3x_3 - 1)(a_{\mathbf{m}})_1(t) + \frac{3}{2\pi m_1} x_3 (b_{\mathbf{m}})_3(t) \right) \cos 2\pi \mathbf{m} \bar{x} \right. \\
&\quad \left. + \left((-3x_3 - 1)(b_{\mathbf{m}})_1(t) - \frac{3}{2\pi m_1} x_3 (a_{\mathbf{m}})_3(t) \right) \sin 2\pi \mathbf{m} \bar{x} \right) \mathbf{e}_1 \\
&- (x_3 + 1) \left(\sum_{m_1, m_2=1}^{\infty} \left((-3x_3 - 1)(a_{\mathbf{m}})_2(t) + \frac{3}{2\pi m_2} x_3 (b_{\mathbf{m}})_3(t) \right) \cos 2\pi \mathbf{m} \bar{x} \right. \\
&\quad \left. + \left((-3x_3 - 1)(b_{\mathbf{m}})_2(t) - \frac{3}{2\pi m_2} x_3 (a_{\mathbf{m}})_3(t) \right) \sin 2\pi \mathbf{m} \bar{x} \right) \mathbf{e}_2 \\
&- (x_3 + 1) \left(\sum_{m_1, m_2=1}^{\infty} \left(2\pi m_1 x_3 (x_3 + 1)(b_{\mathbf{m}})_1(t) + 2\pi m_2 x_3 (x_3 + 1)(b_{\mathbf{m}})_2(t) \right. \right. \\
&\quad \left. \left. + (2x_3^2 + x_3 - 1)(a_{\mathbf{m}})_3(t) \right) \cos 2\pi \mathbf{m} \bar{x} + \left(-2\pi m_1 x_3 (x_3 + 1)(a_{\mathbf{m}})_1(t) \right. \right. \\
&\quad \left. \left. - 2\pi m_2 x_3 (x_3 + 1)(a_{\mathbf{m}})_2(t) + (2x_3^2 + x_3 - 1)(b_{\mathbf{m}})_3(t) \right) \sin 2\pi \mathbf{m} \bar{x} \right) \mathbf{e}_3
\end{aligned} \tag{3.2.49}$$

is a solution for (3.2.48). Moreover, the function ζ_k has the additional properties

$$\begin{aligned}
\zeta_k &\in C^\infty([0, T]; (C^\infty_{\#}(\bar{D}^-))^3), \\
\zeta_k &= 0 \quad \text{in } \bar{D}^- \times [0, \tau_0).
\end{aligned} \tag{3.2.50}$$

The regularity of ζ_k with respect to t and x_1 , stated in (3.2.50)₁, is a consequence of C^∞ -regularity of the function \mathbf{a} given by the induction assumption; relation (3.2.50)₂ is satisfied due to the hypothesis (H3), p. 52. and to the induction assumption.

We define next the function $\omega_k : \bar{D}^- \times [0, T] \mapsto \mathbb{R}^3$, given by

$$\omega_k(x, t) = \hat{\mathbf{v}}_k(x, t) - \zeta_k(x, t), \quad \forall k \geq 0. \tag{3.2.51}$$

Replacing in (3.2.43) the unknown $\hat{\mathbf{v}}_k$ by the new unknown ω_k , using the incompressibility condition and the assumption (H3), p. 52. we obtain for $((\omega_k)_3, \omega_k, p_k)$

the following problem

$$\left\{ \begin{array}{l} \hat{J} \Delta_{\bar{x}}^2 (\hat{w}_k)_3 - \hat{p}_k \Big|_{x_3=0} = G_k(\bar{x}, t) \text{ in } D \times (0, T), \\ \rho_- \frac{\partial \boldsymbol{\omega}_k}{\partial t} - \tilde{\nu} \Delta \boldsymbol{\omega}_k + \nabla \hat{p}_k = \mathbf{F}_k, \\ \operatorname{div} \boldsymbol{\omega}_k = 0 \quad \text{in } D^- \times (0, T), \\ \boldsymbol{\omega}_k(\bar{x}, -1, t) = \mathbf{0} \quad \text{in } D \times (0, T), \\ \boldsymbol{\omega}_k(\bar{x}, 0, t) = \frac{\partial (w_k)_3}{\partial t}(\bar{x}, t) \cdot \mathbf{e}_3 \quad \text{in } D \times (0, T), \\ (w_k)_3, \boldsymbol{\omega}_k, p_k \text{ } D\text{-periodic,} \\ \boldsymbol{\omega}_k(x, 0) = \mathbf{0} \quad \text{in } D^-, \\ (w_k)_3(\bar{x}, 0) = 0 \quad \text{in } D, \ k \geq 0. \end{array} \right. \quad (3.2.52)$$

with

$$\left\{ \begin{array}{l} G_k(\bar{x}, t) = g_3 \delta_{k0} - \mathbf{R}_{k-1} \cdot \mathbf{e}_3 - \hat{E}_1^{-1} \cdot \hat{E}_2 \left(\frac{\partial g_1}{\partial x_1} \delta_{k1} - \frac{\partial \mathbf{R}_{k-1}}{\partial x_1} \cdot \mathbf{e}_1 \right. \\ \quad \left. + \frac{\partial g_2}{\partial x_2} \delta_{k1} - \frac{\partial \mathbf{R}_{k-1}}{\partial x_2} \cdot \mathbf{e}_2 \right) + 2\tilde{\nu} \left(\frac{\partial a_1}{\partial x_1} + \frac{\partial a_2}{\partial x_2} \right), \\ \mathbf{F}_k(x, t) = \mathbf{f}(x, t) \delta_{k0} - \rho_- \frac{\partial \boldsymbol{\zeta}_k}{\partial t}(x, t) + \tilde{\nu} \Delta \boldsymbol{\zeta}_k(x, t). \end{array} \right.$$

Compare now problem (3.2.52) with (2.2.23). We notice that all the equations, initial and boundary conditions are the same; moreover, the known right hand sides of (3.2.52), G_k, \mathbf{F}_k , have the same regularity as g_3, \mathbf{f} , respectively, regularity given by (H1) and (H2), via the induction assumption. Hence, the remaining part of the proof of the proof for an arbitrary value of k , $k \geq 1$, is the same as the one for $k = 0$. The regularity of $\boldsymbol{\omega}_k$ corresponds to the regularity for $\hat{\mathbf{v}}_0$ in Step 2. and $\hat{\mathbf{v}}_k$ has the same regularity as $\boldsymbol{\omega}_k$, due to (3.2.50)₁, which achieves the proof for $k \geq 1$. \square

Proof of Theorem 3.6 for $k \geq 1$. The problem for \mathbf{V}_k , (3.2.44), has the same form for any value of k . Noticing that the regularity of $\boldsymbol{\gamma}_{k-1}$ is $(C^\infty([0, T]))^2$ due to the induction assumption, all the results obtained in Step 2. for \mathbf{V}_0 are still true for \mathbf{V}_k . \square

Step 4. The last step is devoted to the construction of some smooth functions

\mathbf{v}_k and \mathbf{c}_{k-1} that satisfy, together with $(w_k)_3, p_k$ already obtained in Theorem 3.5, problems (3.2.37) and (3.2.39'). Let us define for any $k \geq 0$

$$\begin{cases} \mathbf{v}_k(x, t) = \hat{\mathbf{v}}_k(x, t) + \mathbf{V}_k(x_3, t), \\ \mathbf{c}_{k-1}(t) = \int_0^t \mathbf{V}_k(0, \tau) d\tau. \end{cases} \quad (3.2.53)$$

We prove next that the functions $(w_k)_3, \mathbf{v}_k, p_k, \mathbf{c}_{k-1}$ satisfy all the assertions of Theorem 3.4. The regularity of the functions $\mathbf{v}_k, (w_k)_3, p_k, \mathbf{c}_{k-1}$ is an immediate consequence of the regularity results provided by Theorem 3.5 and Theorem 3.6. Let us show that $\mathbf{v}_k, (w_k)_3, p_k, \mathbf{c}_{k-1}$ satisfy (3.2.37). Notice that \mathbf{c}_{k-1} appears in (3.2.37)_{5,6} being contained in $(\bar{\mathbf{w}}_{k-1})$. Relation (3.2.37)₁ is obtained from (3.2.43)₁ and (3.2.53)₁. Equations (3.2.37)_{2,3} follow from (3.2.43)_{2,3} and (3.2.44)₁. Boundary condition (3.2.37)₄ is a consequence of (3.2.43)₄ and (3.2.44)₃, and (3.2.43)₆ gives (3.2.37)₆. Finally, using (3.2.53), (3.2.43)₅ and (3.2.41) corresponding to $k - 1$, we obtain (3.2.37)₅. It remains to prove that (3.2.39') is fulfilled. Using (3.2.27)₁, (3.2.26), the periodicity of $\frac{\partial(v_k)_3}{\partial x_1}, \frac{\partial(v_k)_3}{\partial x_2}$ and (3.2.53), (3.2.39') can be rewritten in the following form

$$\tilde{\nu} \frac{\partial \mathbf{V}_k}{\partial x_3} \Big|_{x_3=0} (t) = \gamma_{k-1}(t) \quad \forall k \geq 0, \quad (3.2.54)$$

which represents exactly (3.2.44)₂. □

We use next expression (3.2.53)₂ corresponding to $k - 1$ to obtain $(\bar{w}_{k-1})_i, i = 1, 2$. Note that at the k -th approximation, $k \geq 0$ we determine the functions $(w_k)_3, \mathbf{v}_k, p_k$ and $(\bar{w}_{k-1})_i, i = 1, 2$.

We present next the leading term of asymptotic solution (3.2.2). For $k = -1$ (3.2.41) becomes

$$\bar{\mathbf{w}}_{-1}(\bar{x}, t) = \mathbf{c}_{-1}(t), \quad (3.2.55)$$

while $((w_0)_3, \mathbf{v}_0, p_0)$ is the unique solution for

$$\left\{ \begin{array}{l} \hat{J} \Delta_x^2 (w_0)_3 - p_0 \Big|_{x_3=0} = g_3 \quad \text{in } D \times (0, T), \\ \rho_- \frac{\partial \mathbf{v}_0}{\partial t} - \tilde{\nu} \Delta \mathbf{v}_0 + \nabla p_0 = \mathbf{f}, \\ \operatorname{div} \mathbf{v}_0 = 0 \quad \text{in } D^- \times (0, T), \\ \mathbf{v}_0(\bar{x}, -1, t) = \mathbf{0} \quad \text{in } D \times (0, T), \\ \mathbf{v}_0(\bar{x}, 0, t) = (c'_{-1})_1(t) \mathbf{e}_1 + (c'_{-1})_2(t) \mathbf{e}_2 + \frac{\partial (w_0)_3}{\partial t}(\bar{x}, t) \mathbf{e}_3 \quad \text{in } D \times (0, T), \\ (w_0)_3, \mathbf{v}_0, p_0 \text{ } D\text{-periodic}, \\ \mathbf{v}_0(x, 0) = \mathbf{0} \text{ in } D^-; (w_0)_3(x, 0) = 0 \text{ in } D. \end{array} \right. \quad (3.2.56)$$

Taking into account (3.2.22), coupling condition (3.2.56)₅ can be written as

$$\mathbf{v}_0 = \frac{\partial \mathbf{w}_0}{\partial t} \quad \text{on } \Gamma_0. \quad (3.2.57)$$

3.3 Justification of asymptotics and error estimation

In this section we will obtain the error estimates which generally demonstrate the small difference between the real solution and the constructed solution to the main problem. From the previous section we obtain the problem for the

asymptotic solution of order J in the form

$$\left\{ \begin{array}{l} \rho_+ \left(\frac{x_3}{\varepsilon} \right) \frac{\partial^2 \mathbf{u}_\varepsilon^{(J)}}{\partial t^2} - \varepsilon^{-3} \sum_{i,j=1}^3 \frac{\partial}{\partial x_i} \left(A_{ij} \left(\frac{x_3}{\varepsilon} \right) \frac{\partial \mathbf{u}_\varepsilon^{(J)}}{\partial x_j} \right) = \varepsilon^{-1} \mathbf{g} - \tilde{\mathbf{r}}_\varepsilon^{(J),1} \text{ in } D_\varepsilon^+ \times (0, T), \\ \rho_- \frac{\partial \mathbf{v}_\varepsilon^{(J)}}{\partial t} - 2\tilde{\nu} \operatorname{div} \left(D(\mathbf{v}_\varepsilon^{(J)}) \right) + \nabla p_\varepsilon^{(J)} = \mathbf{f} \text{ in } D^- \times (0, T), \\ \operatorname{div} \mathbf{v}_\varepsilon^{(J)} = 0 \text{ in } D^- \times (0, T), \\ \sum_{j=1}^3 A_{3j}(1) \frac{\partial \mathbf{u}_\varepsilon^{(J)}}{\partial x_j} = \mathbf{r}_\varepsilon^{(J),4} \text{ on } \Gamma_\varepsilon^+ \times (0, T), \\ \mathbf{v}_\varepsilon^{(J)} = \mathbf{0} \text{ on } \Gamma^- \times (0, T), \\ \mathbf{v}_\varepsilon^{(J)} - \frac{\partial \mathbf{u}_\varepsilon^{(J)}}{\partial t} = -\mathbf{r}_\varepsilon^{(J),6} \text{ on } \Gamma^0 \times (0, T), \\ -p_\varepsilon^{(J)} \mathbf{e}_3 + 2\tilde{\nu} D(\mathbf{v}_\varepsilon^{(J)}) \mathbf{e}_3 = \varepsilon^{-3} \sum_{j=1}^3 A_{3j}(0) \frac{\partial \mathbf{u}_\varepsilon^{(J)}}{\partial x_j} - \mathbf{r}_\varepsilon^{(J),7} \text{ on } \Gamma^0 \times (0, T), \\ \mathbf{u}_\varepsilon^{(J)}, \mathbf{v}_\varepsilon^{(J)}, p_\varepsilon^{(J)} \quad D\text{-periodic}, \\ \mathbf{u}_\varepsilon^{(J)}(0) = \frac{\partial \mathbf{u}_\varepsilon^{(J)}}{\partial t}(0) = \mathbf{0} \text{ in } D_\varepsilon^+, \\ \mathbf{v}_\varepsilon^{(J)}(0) = \mathbf{0} \text{ in } D^-, \end{array} \right. \quad (3.3.1)$$

where $\mathbf{r}_\varepsilon^{(J),4}$, $\mathbf{r}_\varepsilon^{(J),6}$, $\mathbf{r}_\varepsilon^{(J),7}$ are the residuals defined by (3.2.8), (3.2.33), (3.2.10) and $\tilde{\mathbf{r}}_\varepsilon^{(J),1} = \mathbf{r}_\varepsilon^{(J),1} + \sum_{j=1}^2 \sum_{k=J+1}^{J+r_j} \varepsilon^{k-1} (R_k)_j \mathbf{e}_j + \sum_{k=J+1}^{J+r_3} \varepsilon^k (R_k)_3 \mathbf{e}_3$, $\mathbf{r}_\varepsilon^{(J),1}$ given by (3.2.5).

In order to replace the previous system with another one with homogeneous boundary conditions instead of (3.3.1)_{4,7} we prove the following result

Proposition 3.7. *The problem*

$$\left\{ \begin{array}{l} \text{Find } \varphi_\varepsilon^{(J)} : \bar{D}_\varepsilon^+ \times [0, T] \mapsto \mathbb{R}^3 \text{ such that} \\ \varphi_\varepsilon^{(J)} \text{ } D\text{-periodic}, \\ \sum_{j=1}^3 A_{3j}(1) \frac{\partial \varphi_\varepsilon^{(J)}}{\partial x_j}(\bar{x}, \varepsilon, t) = \mathbf{r}_\varepsilon^{(J),4}(\bar{x}, t) \text{ in } \bar{D} \times [0, T], \\ \sum_{j=1}^3 A_{3j}(0) \frac{\partial \varphi_\varepsilon^{(J)}}{\partial x_j}(\bar{x}, 0, t) = \varepsilon^3 \mathbf{r}_\varepsilon^{(J),7}(\bar{x}, t) \text{ in } \bar{D} \times [0, T] \end{array} \right. \quad (3.3.2)$$

has at least a solution.

Proof. It can be easily verified that the function

$$\begin{aligned} \varphi_\varepsilon^{(J)}(x, t) = & x_3(x_3 - \varepsilon) \left(\sum_{j=1}^2 \left(\frac{\varepsilon(x_3 - \varepsilon)}{\mu(0)} (r_\varepsilon^{(J),7})_j(\bar{x}, t) + \frac{x_3}{\varepsilon^2 \mu(1)} (r_\varepsilon^{(J),4})_j(\bar{x}, t) \right) \mathbf{e}_j \right. \\ & \left. + \left(\frac{\varepsilon(x_3 - \varepsilon)}{\lambda(0) + 2\mu(0)} (r_\varepsilon^{(J),7})_3(\bar{x}, t) + \frac{x_3}{\varepsilon^2(\lambda(1) + 2\mu(1))} (r_\varepsilon^{(J),4})_3(\bar{x}, t) \right) \mathbf{e}_3 \right) \end{aligned} \quad (3.3.3)$$

has the properties stated in (3.3.2). \square

We define next

$$\mathbf{U}_\varepsilon^{(J)} = \mathbf{u}_\varepsilon^{(J)} - \varphi_\varepsilon^{(J)} \quad (3.3.4)$$

and $(\hat{\mathbf{U}}_\varepsilon^{(J)}, \hat{\mathbf{v}}_\varepsilon^{(J)}, \hat{p}_\varepsilon^{(J)}) = (\mathbf{u}_\varepsilon, \mathbf{v}_\varepsilon, p_\varepsilon) - (\mathbf{U}_\varepsilon^{(J)}, \mathbf{v}_\varepsilon^{(J)}, p_\varepsilon^{(J)})$ and, from (2.1.1), (3.3.1) and (3.3.2) we obtain

$$\left\{ \begin{array}{l} \rho_+ \left(\frac{x_3}{\varepsilon} \right) \frac{\partial^2 \hat{\mathbf{U}}_\varepsilon^{(J)}}{\partial t^2} - \varepsilon^{-3} \sum_{i,j=1}^3 \frac{\partial}{\partial x_i} \left(A_{ij} \left(\frac{x_3}{\varepsilon} \right) \frac{\partial \hat{\mathbf{U}}_\varepsilon^{(J)}}{\partial x_j} \right) = -\mathbf{g}_\varepsilon^{(J)} \text{ in } D_\varepsilon^+ \times (0, T), \\ \rho_- \frac{\partial \hat{\mathbf{v}}_\varepsilon^{(J)}}{\partial t} - 2\tilde{\nu} \operatorname{div} \left(D(\hat{\mathbf{v}}_\varepsilon^{(J)}) \right) + \nabla \hat{p}_\varepsilon^{(J)} = \mathbf{0} \text{ in } D^- \times (0, T), \\ \operatorname{div} \hat{\mathbf{v}}_\varepsilon^{(J)} = 0 \text{ in } D^- \times (0, T), \\ \sum_{j=1}^3 A_{3j}(1) \frac{\partial \hat{\mathbf{U}}_\varepsilon^{(J)}}{\partial x_j} = \mathbf{0} \text{ on } \Gamma_\varepsilon^+ \times (0, T), \\ \hat{\mathbf{v}}_\varepsilon^{(J)} = \mathbf{0} \text{ on } \Gamma^- \times (0, T), \\ \hat{\mathbf{v}}_\varepsilon^{(J)} - \frac{\partial \hat{\mathbf{U}}_\varepsilon^{(J)}}{\partial t} = \mathbf{r}_\varepsilon^{(J),6} \text{ on } \Gamma^0 \times (0, T), \\ -\hat{p}_\varepsilon^{(J)} \mathbf{e}_3 + 2\tilde{\nu} D(\hat{\mathbf{v}}_\varepsilon^{(J)}) \mathbf{e}_3 = \varepsilon^{-3} \sum_{j=1}^3 A_{3j}(0) \frac{\partial \hat{\mathbf{U}}_\varepsilon^{(J)}}{\partial x_j} \text{ on } \Gamma^0 \times (0, T), \\ \hat{\mathbf{U}}_\varepsilon^{(J)}, \hat{\mathbf{v}}_\varepsilon^{(J)}, \hat{p}_\varepsilon^{(J)} \quad D\text{-periodic}, \\ \hat{\mathbf{U}}_\varepsilon^{(J)}(0) = \frac{\partial \hat{\mathbf{U}}_\varepsilon^{(J)}}{\partial t}(0) = \mathbf{0} \text{ in } D_\varepsilon^+, \\ \hat{\mathbf{v}}_\varepsilon^{(J)}(0) = \mathbf{0} \text{ in } D^-, \end{array} \right. \quad (3.3.5)$$

where

$$\mathbf{g}_\varepsilon^{(J)} = -\tilde{\mathbf{r}}_\varepsilon^{(J),1} - \rho_+ \frac{\partial^2 \boldsymbol{\varphi}_\varepsilon^{(J)}}{\partial t^2} + \varepsilon^{-3} \sum_{i,j=1}^3 \frac{\partial}{\partial x_i} \left(A_{ij} \frac{\partial \boldsymbol{\varphi}_\varepsilon^{(J)}}{\partial x_j} \right). \quad (3.3.6)$$

The first estimates between the exact solution and the asymptotic solution of order J are given by

Theorem 3.8. *Let $(\mathbf{u}_\varepsilon, \mathbf{v}_\varepsilon, p_\varepsilon)$ be the exact solution of (2.1.1) and $(\mathbf{u}_\varepsilon^{(J)}, \mathbf{v}_\varepsilon^{(J)}, p_\varepsilon^{(J)})$ the asymptotic solution of order J , defined by (3.2.1). Then the following estimates hold*

$$\left\{ \begin{array}{l} \left\| \frac{\partial}{\partial t} (\mathbf{u}_\varepsilon - \mathbf{u}_\varepsilon^{(J)}) \right\|_{L^\infty(0,T;(L^2(D_\varepsilon^+))^2)} = \mathcal{O}(\varepsilon^{J-7/2}), \\ \left\| \frac{\partial^2}{\partial t^2} (\mathbf{u}_\varepsilon - \mathbf{u}_\varepsilon^{(J)}) \right\|_{L^\infty(0,T;(L^2(D_\varepsilon^+))^2)} = \mathcal{O}(\varepsilon^{J-7/2}), \\ \left\| \mathcal{E}_x(\mathbf{u}_\varepsilon - \mathbf{u}_\varepsilon^{(J)}) \right\|_{L^\infty(0,T;(L^2(D_\varepsilon^+))^{3 \times 3})} = \mathcal{O}(\varepsilon^{J-2}), \\ \left\| \mathbf{v}_\varepsilon - \mathbf{v}_\varepsilon^{(J)} \right\|_{L^\infty(0,T;(L^2(D^-))^2)} = \mathcal{O}(\varepsilon^{J-7/2}), \\ \left\| \frac{\partial}{\partial t} (\mathbf{v}_\varepsilon - \mathbf{v}_\varepsilon^{(J)}) \right\|_{L^\infty(0,T;(L^2(D^-))^2)} = \mathcal{O}(\varepsilon^{J-7/2}), \\ \left\| D_x(\mathbf{v}_\varepsilon - \mathbf{v}_\varepsilon^{(J)}) \right\|_{L^2(0,T;(L^2(D^-))^{3 \times 3})} = \mathcal{O}(\varepsilon^{J-7/2}), \\ \left\| p_\varepsilon - p_\varepsilon^{(J)} \right\|_{L^2(0,T;L^2(D^-))} = \mathcal{O}(\varepsilon^{J-13/2}). \end{array} \right. \quad (3.3.7)$$

Proof. Computing $\int_{D_\varepsilon^+} (3.3.5)_1 \cdot \left(\frac{\partial \hat{\mathbf{U}}_\varepsilon^{(J)}}{\partial t} + \mathbf{r}_\varepsilon^{(J),6} \right) + \int_{D^-} (3.3.5)_2 \cdot \hat{\mathbf{v}}_\varepsilon^{(J)}$ we obtain in the same way as in [1, 2] estimates (3.3.7)₁₋₆. We notice the difference that appears in (3.3.7)_{1,2} with respect to the corresponding estimates from [1, 2] due to the fact that here the density of the elastic material is of order 1 where in [1, 2] is $\mathcal{O}(\varepsilon^{-1})$. In what follows we establish a more precise estimate for the pressure than in [1, 2].

Let us consider a pair $(\boldsymbol{\varphi}, \boldsymbol{\omega}) \in (H^1(D_\varepsilon^+))^3 \times (H^1(D^-))^3$ with the properties: $\boldsymbol{\varphi} = \mathbf{0}$ on $\partial D_\varepsilon^+ \setminus \Gamma^0$, $\boldsymbol{\omega} = \mathbf{0}$ on $\partial D^- \setminus \Gamma^0$, $\boldsymbol{\varphi} = \boldsymbol{\omega}$ on Γ^0 . Computing $\int_{D_\varepsilon^+} (3.3.5)_1 \cdot \boldsymbol{\varphi} + \int_{D^-} (3.3.5)_2 \cdot \boldsymbol{\omega}$ and using (3.3.5)₇ we get

$$L(\boldsymbol{\varphi}, \boldsymbol{\omega})(t) = \int_{D^-} \hat{p}_\varepsilon^{(J)}(t) \operatorname{div} \boldsymbol{\omega} \quad \text{a.e. in } (0, T), \quad (3.3.8)$$

with

$$\begin{aligned}
L(\boldsymbol{\varphi}, \boldsymbol{\omega})(t) &= \int_{D_\varepsilon^+} \rho_+ \frac{\partial^2 \hat{\mathbf{U}}_\varepsilon^{(J)}(t)}{\partial t^2} \cdot \boldsymbol{\varphi} + \varepsilon^{-3} \int_{D_\varepsilon^+} \sum_{i,j=1}^3 A_{ij} \frac{\partial \hat{\mathbf{U}}_\varepsilon^{(J)}(t)}{\partial x_j} \cdot \frac{\partial \boldsymbol{\varphi}}{\partial x_i} \\
&+ \int_{D_\varepsilon^+} \mathbf{g}_\varepsilon^{(J)}(t) \cdot \boldsymbol{\varphi} + \rho_- \int_{D^-} \frac{\partial \hat{\mathbf{v}}_\varepsilon^{(J)}(t)}{\partial t} \cdot \boldsymbol{\omega} + 2\tilde{\nu} \int_{D^-} D(\hat{\mathbf{v}}_\varepsilon^{(J)}(t)) : D(\boldsymbol{\omega}) \quad \text{a.e. in } (0, T).
\end{aligned} \tag{3.3.9}$$

We introduce the notation

$$\begin{cases} A(\mathbf{u}(t)) = c_1 \left\| \frac{\partial^2 \mathbf{u}}{\partial t^2}(t) \right\|_{(L^2(D_\varepsilon^+))^3} + c_2 \varepsilon^{-3} \left\| \mathcal{E}(\mathbf{u}(t)) \right\|_{(L^2(D_\varepsilon^+))^9} + c_3 \left\| \mathbf{g}_\varepsilon^{(J)}(t) \right\|_{(L^2(D_\varepsilon^+))^3}, \\ B(\mathbf{v}(t)) = c_4 \left\| \frac{\partial \mathbf{v}}{\partial t}(t) \right\|_{(L^2(D^-))^3} + 2\tilde{\nu} \left\| D(\mathbf{v}(t)) \right\|_{(L^2(D^-))^{3 \times 3}}, \end{cases} \tag{3.3.10}$$

where c_1, c_2, c_3, c_4 are positive known constants independent of ε .

Applying Poincaré's inequality and an obvious estimate for the second term of the right-hand side of (5.9) it follows that

$$\begin{cases} |L(\boldsymbol{\varphi}, \boldsymbol{\omega})(t)| \leq A(\hat{\mathbf{U}}_\varepsilon^{(J)}(t)) \left\| \nabla \boldsymbol{\varphi} \right\|_{(L^2(D_\varepsilon^+))^{3 \times 3}} + B(\hat{\mathbf{v}}_\varepsilon^{(J)}(t)) \left\| \nabla \boldsymbol{\omega} \right\|_{(L^2(D^-))^{3 \times 3}} \\ \text{a.e. in } (0, T), (\forall) (\boldsymbol{\varphi}, \boldsymbol{\omega}) \in (H^1(D_\varepsilon^+))^3 \times (H^1(D^-))^3 : \\ \boldsymbol{\varphi} = \mathbf{0} \text{ on } \partial D_\varepsilon^+ \setminus \Gamma^0, \boldsymbol{\omega} = \mathbf{0} \text{ on } \partial D^- \setminus \Gamma^0, \boldsymbol{\varphi} = \boldsymbol{\omega} \text{ on } \Gamma^0. \end{cases} \tag{3.3.11}$$

We choose next some particular functions $\boldsymbol{\omega}$ and $\boldsymbol{\varphi}$ in (3.3.11). We begin with the construction of $\boldsymbol{\omega}$. For this purpose, we consider an arbitrary function $\eta : \bar{D} \rightarrow \mathbb{R}$ with the properties:

$$\begin{cases} \int_D \eta = 1, \\ \eta = 0 \text{ on } \partial D, \\ \eta \in C^{1,1}(\bar{D}) \end{cases} \tag{3.3.12}$$

and the problem:

$$\left\{ \begin{array}{l} \text{Find } \boldsymbol{\omega} \in (H^1(D^-))^3, \text{ such that} \\ \operatorname{div} \boldsymbol{\omega} = \hat{p}_\varepsilon^{(J)}(t) \text{ a.e. in } D^-, \\ \boldsymbol{\omega} = \mathbf{0} \text{ on } \partial D^- \setminus \Gamma^0, \\ \boldsymbol{\omega} = \eta \left(\int_{D^-} \hat{p}_\varepsilon^{(J)}(t) \right) \mathbf{e}_3 \text{ on } \Gamma^0. \end{array} \right. \quad (3.3.13)$$

Applying a result of [84, Chap.III.3] it follows that there exists a function $\boldsymbol{\omega}$ satisfying (3.3.13) and

$$\|\boldsymbol{\omega}\|_{(H^1(D^-))^3} \leq C(D^-) \left(1 + \|\eta\|_{H^{1/2}(D)}\right) \|\hat{p}_\varepsilon^{(J)}(t)\|_{L^2(D^-)}. \quad (3.3.14)$$

We consider next the problem for $\boldsymbol{\varphi}$:

$$\left\{ \begin{array}{l} \text{Find } \boldsymbol{\varphi} \in (H^1(D_\varepsilon^+))^3, \text{ such that} \\ \operatorname{div} \boldsymbol{\varphi} = \varepsilon^{-1} \int_{D^-} \hat{p}_\varepsilon^{(J)}(t) \text{ a.e. in } D_\varepsilon^+, \\ \boldsymbol{\varphi} = \mathbf{0} \text{ on } \partial D_\varepsilon^+ \setminus \Gamma^0, \\ \boldsymbol{\varphi} = \eta \left(\int_{D^-} \hat{p}_\varepsilon^{(J)}(t) \right) \mathbf{e}_3 \text{ on } \Gamma^0. \end{array} \right. \quad (3.3.15)$$

By transforming (3.3.15) into a problem on the domain independent of ε , $D^+ = (0, 1)^3$, with the change of function $\boldsymbol{\psi} : \bar{D}^+ \rightarrow \mathbb{R}^3$,

$$\boldsymbol{\psi}(\bar{x}, \xi_3) = \sum_{j=1}^2 \varphi_j(x) \mathbf{e}_j + \varepsilon^{-1} \varphi_3(x) \mathbf{e}_3 \quad (3.3.16)$$

we obtain as before a solution $\boldsymbol{\varphi}$ for (3.3.15) satisfying the estimate

$$\|\boldsymbol{\varphi}\|_{(H^1(D_\varepsilon^+))^3} \leq \frac{C(D^+)}{\varepsilon^{3/2}} \left(1 + \|\eta\|_{H^{1/2}(D)}\right) \|\hat{p}_\varepsilon^{(J)}(t)\|_{L^2(D^-)}, \quad (3.3.17)$$

with the constant $C(D^+)$ independent of ε .

From (3.3.8), (3.3.9), (3.3.13)₂, (3.3.14) and (3.3.17) we finally obtain

$$\begin{aligned}
& \left\| \hat{p}_\varepsilon^{(J)}(t) \right\|_{L^2(0,T;L^2(D^-))}^2 \leq a_1 \varepsilon^{-3} \left\| \frac{\partial^2 \hat{\mathbf{U}}_\varepsilon^{(J)}}{\partial t^2} \right\|_{L^2(0,T;(L^2(D_\varepsilon^+))^3)}^2 \\
& + a_2 \varepsilon^{-9} \left\| \mathcal{E}(\hat{\mathbf{U}}_\varepsilon^{(J)}) \right\|_{L^2(0,T;(L^2(D_\varepsilon^+))^{3 \times 3})}^2 + a_3 \varepsilon^{-3} \left\| \mathbf{g}_\varepsilon^{(J)} \right\|_{L^2(0,T;(L^2(D_\varepsilon^+))^3)}^2 \\
& + a_4 \left\| \frac{\partial \hat{\mathbf{v}}_\varepsilon^{(J)}}{\partial t} \right\|_{L^2(0,T;(L^2(D^-))^{3 \times 3})} + a_5 \left\| D(\hat{\mathbf{v}}_\varepsilon^{(J)}) \right\|_{L^2(0,T;(L^2(D^-))^{3 \times 3})},
\end{aligned} \tag{3.3.18}$$

with a_1, \dots, a_5 positive constants independent of ε .

Estimate (3.3.7)₇ follows from (3.3.18), (3.3.7)_{2,3,5,6}, which achieves the proof. \square

As one can see, the error between the exact solution and the asymptotic solution of order J is big if $J \leq 6$. The last result of this section is devoted to the improvement of the previous estimates.

Theorem 3.9. *Let $(\mathbf{u}_\varepsilon, \mathbf{v}_\varepsilon, p_\varepsilon)$ be the exact solution of (2.1.1) and $(\mathbf{u}_\varepsilon^{(K)}, \mathbf{v}_\varepsilon^{(K)}, p_\varepsilon^{(K)})$ the asymptotic solution of order K , defined by (3.2.1). Then the error between these two solutions is given by*

$$\left\{ \begin{array}{l} \left\| \frac{\partial}{\partial t} (\mathbf{u}_\varepsilon - \mathbf{u}_\varepsilon^{(K)}) \right\|_{L^\infty(0,T;(L^2(D_\varepsilon^+))^2)} = \mathcal{O}(\varepsilon^{K+3/2}), \\ \left\| \frac{\partial^2}{\partial t^2} (\mathbf{u}_\varepsilon - \mathbf{u}_\varepsilon^{(K)}) \right\|_{L^\infty(0,T;(L^2(D_\varepsilon^+))^2)} = \mathcal{O}(\varepsilon^{K+3/2}), \\ \left\| \mathcal{E}_x(\mathbf{u}_\varepsilon - \mathbf{u}_\varepsilon^{(K)}) \right\|_{L^\infty(0,T;(L^2(D_\varepsilon^+))^{3 \times 3})} = \mathcal{O}(\varepsilon^{K+1/2}), \\ \left\| \mathbf{v}_\varepsilon - \mathbf{v}_\varepsilon^{(K)} \right\|_{L^\infty(0,T;(L^2(D^-))^2)} = \mathcal{O}(\varepsilon^{K+1}), \\ \left\| \frac{\partial}{\partial t} (\mathbf{v}_\varepsilon - \mathbf{v}_\varepsilon^{(K)}) \right\|_{L^\infty(0,T;(L^2(D^-))^2)} = \mathcal{O}(\varepsilon^{K+1}), \\ \left\| D_x(\mathbf{v}_\varepsilon - \mathbf{v}_\varepsilon^{(K)}) \right\|_{L^2(0,T;(L^2(D^-))^{3 \times 3})} = \mathcal{O}(\varepsilon^{K+1}), \\ \left\| p_\varepsilon - p_\varepsilon^{(K)} \right\|_{L^2(0,T;L^2(D^-))} = \mathcal{O}(\varepsilon^{K+1}). \end{array} \right. \tag{3.3.19}$$

Proof. We consider $K \geq 0$ a fixed integer and $J > K + 7$. Let us prove, for instance, (3.3.19)₁. Computing the order of $\frac{\partial}{\partial t} (\mathbf{u}_\varepsilon^{(J)} - \mathbf{u}_\varepsilon^{(K)})$ from (3.2.2)₁ we obtain $\frac{\partial}{\partial t} (\mathbf{u}_\varepsilon^{(J)} - \mathbf{u}_\varepsilon^{(K)}) = \mathcal{O}(\varepsilon^{K+1})$ which gives, together with (3.3.7)₁,

$$\left\| \frac{\partial}{\partial t} \left(\mathbf{u}_\varepsilon - \mathbf{u}_\varepsilon^{(K)} \right) (t) \right\|_{(L^2(D_\varepsilon^+))^2} = \mathcal{O}(\varepsilon^{J-7/2}) + \mathcal{O}(\varepsilon^{K+3/2}).$$
 Since $J > K + 4$, we get (3.3.19)₁. All the other estimates from (3.3.19) are obtained in a same way, from (3.3.7) and (3.2.1), and the proof is completed. \square

3.4 Conclusion

We have constructed the complete asymptotic expansion of the solution. Homogenization is used. The limit problem describes the principal term of the asymptotic expansion.

Conclusion

Le problème d'interaction d'un fluide visqueux avec une structure élastique est considéré. On généralise l'investigation du problème d'interaction du fluide visqueux avec la plaque mince élastique en 2D [1,2] ici en cas 3D. Dans l'analyse variationnelle une nouvelle idée est de considérer la même fonction pour la vitesse du fluide \mathbf{v}_ε et la vitesse dans la zone élastique $\frac{\partial \mathbf{u}_\varepsilon}{\partial t}$. Cela permet de réduire le volume de la preuve en utilisant un ensemble des approximations de Galerkin à la place de deux (pour le milieu liquide et le milieu élastique). La caractéristique distinctive principale du système couplé "flux fluide visqueux – plaque mince élastique" en 3D du cas deux-dimensionnel est dans l'analyse asymptotique : lorsque nous construisons le développement asymptotique nous n'avons plus de termes que nous pouvons déterminer explicitement, nous avons maintenant des systèmes pour eux. Et comme avant, nous avons réussi à la différenciation entre les deux problèmes : pour les parties solides et liquides. Les résultats d'application physique sont suivent : la formation des contraintes résiduelles pendant le traitement des matériaux par laser est étudié utilisant un modèle thermo-élastique. Les résultats des calculs numériques peuvent être utilisés pour évaluer la stabilité thermomécanique des matériaux dans la FSL. La représentation graphique des champs deux-dimensionnels est obtenue numériquement avec une base des données des propriétés thermoélastiques des matériaux métalliques, céramiques et polymères.

Conclusion

Viscous fluid-structure interaction problem is considered. The investigation of the viscous fluid-thin elastic plate interaction in 2D [1, 2] is generalized here to 3D case. In variational analysis a new idea is to consider one function for the fluid velocity \mathbf{v}_ε and the velocity in the elastic area $\frac{\partial \mathbf{u}_\varepsilon}{\partial t}$. This allows to reduce a proof volume using one set of Galerkin approximations in place of two (for the fluid and elastic mediums). The main distinguishing feature of the coupled system “viscous fluid flow-thin elastic plate” in 3D from the 2D-case is in the asymptotic analysis: when we construct the asymptotic expansion we have no more terms that we can determine explicitly, we have now the systems for them. And as before, we succeeded in differentiation between two problems: for the solid and fluid parts. Physical application results are following : the formation of residual stresses during the laser treatment of materials is studied using a thermo-elastic model. Calculation results can be used to evaluate the thermomechanical stability of the materials in the SLM process. The graphical representation of the two-dimensional fields is obtained numerically with a database of thermoelastic properties of metallic, ceramic and polymer materials.

Bibliography

1. G.P. Panasenko and R. Stavre. Asymptotic analysis of a viscous fluid-thin plate interaction: periodic flow. *C.R. Mécanique*, **340**:590–595, 2012.
2. G.P. Panasenko and R. Stavre. Asymptotic analysis of a viscous fluid-thin plate interaction: periodic flow. *Math. Mod. Meth. Appl. Sci.*, **24**:1781–1822, 2014.
3. G.P. Panasenko and R. Stavre. Asymptotic analysis of a non-periodic flow in a thin channel with visco-elastic wall. *Netw. Heterog. Media*, **3**:651–673, 2008.
4. R. Stavre and G.P. Panasenko. Asymptotic analysis of the Stokes flow with variable viscosity in a thin elastic channel. *Netw. Heterog. Media*, **5**:783–812, 2010.
5. C. Grandmont. Existence et unicité de solutions d’un problème de couplage fluide-structure bidimensionnel stationnaire. *Comptes Rendus de l’Académie des Sciences - Series I - Mathematics*, **326**:651–656, March 1998.
6. C. Grandmont and Y. Maday. Existence for an unsteady fluid-structure interaction problem. *ESAIM: Math. Model. Numer. Anal.*, **34**:609–636, 2000.
7. C. Grandmont. Analyse mathématique et numérique de problèmes d’interaction fluide-structure. Application a la modélisation de l’appareil respiratoire., November 2009.
8. F. Flori and P. Orenca. Fluid-structure interaction: analysis of a 3-D compressible model. *Annales de l’Institut Henri Poincaré (C) Non Linear Analysis*, **17**:753–777, 2000.

9. B. Muha and S. Čanić. Existence of a weak solution to a nonlinear fluid-structure interaction problem modeling the flow of an incompressible, viscous fluid in a cylinder with deformable walls. page 64, July 2012.
10. B. Muha and S. Čanić. Existence of a solution to a fluid-multi-layered-structure interaction problem. page 48, May 2013.
11. G.P. Panasenko and R. Stavre. Asymptotic analysis of the Stokes flow in a thin cylindrical elastic tube. *Appl. Anal.*, **91**:1999–2027, 2012.
12. G.P. Panasenko and R. Stavre. Viscous fluid-thin cylindrical elastic layer interaction: asymptotic analysis. *Appl. Anal.*, **93**:2032–2056, 2014.
13. M. Bukač, S. Čanić, R. Glowinski, J. Tambača, and A. Quaini. Fluid-structure interaction in blood flow capturing non-zero longitudinal structure displacement. June 2012.
14. M. Bukač, S. Čanić, R. Glowinski, B. Muha, and A. Quaini. A Modular, Operator Splitting Scheme for Fluid-Structure Interaction Problems with Thick Structures. November 2013.
15. A. Mikelić, G. Guidoboni, and S. Čanić. Fluid-structure interaction in a prestressed tube with thick elastic walls. I. The stationary Stokes problem. *Netw. Heterog. Media*, **2**:397–423, 2007.
16. J. Degroote, A. Souto-Iglesias, W. Van Paepegem, S. Annerel, P. Bruggeman, and J. Vierendeels. Partitioned simulation of the interaction between an elastic structure and free surface flow. *Computer Methods in Applied Mechanics and Engineering*, **199**:2085–2098, 2010.
17. B. Desjardins, M.J. Esteban, C. Grandmont, and P. Le Tallec. Weak solutions for a fluid-elastic structure interaction model. *Revista Matemática Complutense*, **14**:523 – 538, 2001.
18. G.P. Panasenko and R. Stavre. Asymptotic analysis of a periodic flow in a thin channel with visco-elastic wall. *J. Math. Pures Appl.*, **85**:558–579, 2006.
19. S. Čanić and A. Mikelić. Effective Equations Modeling the Flow of a Viscous Incompressible Fluid through a Long Elastic Tube Arising in the Study of

- Blood Flow through Small Arteries. *SIAM Journal on Applied Dynamical Systems*, **2**:431–463, January 2003.
20. S. Čanić, D. Lamponi, A. Mikelić, and J. Tambača. Self-Consistent Effective Equations Modeling Blood Flow in Medium-to-Large Compliant Arteries. *Multiscale Modeling & Simulation*, **3**:559–596, January 2005.
21. S.A. Nazarov, J. Taskinen, and J.H. Videman. Asymptotic behavior of trapped modes in two-layer fluids. *Wave Motion*, **50**:111–126, March 2013.
22. G.P. Panasenko and E. Pérez. Asymptotic partial decomposition of domain for spectral problems in rod structures. *Journal de Mathématiques Pures et Appliquées*, **87**:1–36, January 2007.
23. Landau, L.D. and Lifshitz, E.M. *Theory of Elasticity*. Pergamon Press, 1986.
24. R. Temam. *Navier-Stokes Equations: Theory & Numerical Analysis*. North-Holland, 1984.
25. S. Čanić and A. Mikelić. Effective equations describing the flow of a viscous incompressible fluid through a long elastic tube. *Comptes Rendus Mécanique*, **330**:661–666, 2002.
26. A.V. Gusarov, I.S. Malahova-Zyablova, and A.V. Perestoronina. Raschyot ostatochnih napryazhenii pri selektivnom lazernom plavlenii poroshkov (Calculation of Residual Stresses under Selective Laser Melting of Powders). *Metallfiz. Noveishie Tekhnol.*, **35**:1501–1516, 2013.
27. A.V. Gusarov, I.S. Malakhova-Ziablova, and M.D. Pavlov. Thermoelastic Residual Stresses and Deformations at Laser Treatment. *Physics Procedia*, **41**:896–903, 2013.
28. I.V. Shishkovsky. *Lazernii sintez funktsional'no-gradientnih mezostruktur i ob'yomnih izdelii (Laser Synthesis of Functional Mesostructures and 3D Articles)*. Fizmatlit, Moscow, 2009.
29. I. Yadroitsev. *Selective laser melting: Direct manufacturing of 3D-objects by selective laser melting of metal powders [Paperback]*. Lap Lambert, Saarbrücken, 2009.

30. G.G. Gladush and I. Smurov. *Physics of Laser Materials Processing: theory and experiment*. Springer, Berlin, Heidelberg, 2011.
31. I.Yu. Smurov, I.A. Movchan, I.A. Yadroitsev, A.A. Okun'kova, S.G. Konov, and G.V. Antonenkova. Eksperimental'noe additivnoe pryamoe proizvodstvo s pomosh'yu lazera (Experimental additive direct manufacturing by laser). *Vestnik MGTU STANKIN*, **2 (20)**, 2012.
32. I.Yu. Smurov, I.A. Yadroitsev, I.A. Movchan, A.A. Okun'kova, N.Yu. Cherkasova, and G.V. Antonenkova. Additivnoe proizvodstvo s pomosh'yu lazera. Provedenie eksperimental'nih rabot (Additive manufacturing with a laser. Experimental work). *Vestnik MGTU STANKIN*, **1 (18)**, 2012.
33. A.P. Nazarov and A.A. Okun'kova. Tehnologiya selektivnogo lazernogo spekaniya (Selective laser sintering technology). *Vestnik mashinostroeniya*, **11**, 2012.
34. L. Thijs, F. Verhaeghe, T. Craeghs, J. Van Humbeeck, and J.-P. Kruth. A study of the microstructural evolution during selective laser melting of Ti-6Al-4V. *Acta Materialia*, **58**:3303–3312, 2010.
35. V. Yu. Fominskii, S. N. Grigoriev, A. G. Gnedovets, and R. I. Romanov. Specific features of ion-initiated processes during pulsed laser deposition of MoSe₂ coatings in pulsed electric fields. *Technical Physics Letters*, **38**:683–686, August 2012.
36. S.N. Grigoriev, V.Yu. Fominski, A.G. Gnedovets, and R.I. Romanov. Experimental and numerical study of the chemical composition of WSex thin films obtained by pulsed laser deposition in vacuum and in a buffer gas atmosphere. *Applied Surface Science*, **258**:7000–7007, July 2012.
37. A.V. Gusarov. *Fizicheskie modeli vozdeistviya lazernogo izlucheniya na kondensirovannye veschestva v lazernoi tehnologii polucheniya materialov (Physical models of laser impact on condensed substances in laser technology of production of materials)*. PhD thesis, IMET RAN, 2011.

38. A. V. Gusarov, I. Yadroitsev, Ph. Bertrand, and I. Smurov. Model of Radiation and Heat Transfer in Laser-Powder Interaction Zone at Selective Laser Melting. *Journal of Heat Transfer*, **131**:072101, July 2009.
39. F. Verhaeghe, T. Craeghs, J. Heulens, and L. Pandelaers. A pragmatic model for selective laser melting with evaporation. *Acta Materialia*, **57**:6006–6012, December 2009.
40. I. Yadroitsev, A. Gusarov, I. Yadroitsava, and I. Smurov. Single track formation in selective laser melting of metal powders. *Journal of Materials Processing Technology*, **210**:1624–1631, 2010.
41. A.V. Gusarov and I. Smurov. Modeling the interaction of laser radiation with powder bed at selective laser melting. *Physics Procedia*, **5**:381–394, January 2010.
42. M. Doubenskaia, M. Pavlov, S. Grigoriev, E. Tikhonova, and I. Smurov. Comprehensive Optical Monitoring of Selective Laser Melting. *JLMN-Journal of Laser Micro/Nanoengineering*, **7**:236–243, 2012.
43. I. Smurov, M. Doubenskaia, S. Grigoriev, and A. Nazarov. Optical Monitoring in Laser Cladding of Ti6Al4V. *Journal of Thermal Spray Technology*, **21**:1357–1362, July 2012.
44. S.N. Grigoriev, V.Yu. Fominskii, and A.V. Gusarov. Features of micro- and nanostructures of Au–Ni alloys obtained on nickel due to different modes of pulse laser alloying. *Metal Science and Heat Treatment*, **54**:34–40, May 2012.
45. J.C. Brice. The cracking of Czochralski-grown crystals. *Journal of Crystal Growth*, **42**:427–430, 1977.
46. D. Triantafyllidis, L. Li, and F.H. Stott. Crack-free densification of ceramics by laser surface treatment. *Surface and Coatings Technology*, **201**:3163–3173, December 2006.
47. F.P. Glasser and Xiping Jing. Laser melting of refractory Al₂O₃-ZrO₂ ceramics. *British ceramic. Transactions and journal*, **91**:195–198, 1992.

48. J. Gurauskis, V. Lennikov, G.F. de la Fuente, and R.I. Merino. Laser-assisted, crack-free surface melting of large eutectic ceramic bodies. *Journal of the European Ceramic Society*, **31**:1251–1256, 2011.
49. Y.-C. Hagedorn, J. Wilkes, W. Meiners, K. Wissenbach, and R. Poprawe. Net shaped high performance oxide ceramic parts by selective laser melting. *Physics Procedia*, **5**:587–594, 2010.
50. H. Maruo, I. Miyamoto, Y. Inoue, and Y. Arata. CO₂ Laser Welding of Ceramics (Report 1). *J. Japan Welding Society*, **51**:182–189, 1982.
51. S. Ghosh and J. Choi. Modeling and Experimental Verification of Transient/Residual Stresses and Microstructure Formation in Multi-Layer Laser Aided DMD Process. *Journal of Heat Transfer*, **128**:662–679, July 2006.
52. F. Brückner, D. Lepski, and E. Beyer. Modeling the Influence of Process Parameters and Additional Heat Sources on Residual Stresses in Laser Cladding. *Journal of Thermal Spray Technology*, **16**:355–373, 2007.
53. A.V. Gusarov, M. Pavlov, and I. Smurov. Residual Stresses at Laser Surface Remelting and Additive Manufacturing. *Physics Procedia*, **12**:248–254, 2011.
54. E.V. Ryzhkov, M.D. Pavlov, A.V. Gusarov, Yu.A. Artyomenko, and V.V. Vasil'tsov. Obrazovanie treschin pri selektivnom lazernom spekanii keramiki (Crack formation in ceramics under selective laser sintering). *Fizika I Himiya Obrabotki Materialov*, **1**:77–83, 2011.
55. N. Bakhvalov and G. Panasenko. *Homogenisation: Averaging Processes in Periodic Media* 36volume, **series, Mathematics and its Applications**. Springer Netherlands, Dordrecht, 1989.
56. O.A. Oleinik, A.S. Shamaev, and G.A. Yosifian. *Mathematical Problems in Elasticity and Homogenization* 2volume. Elsevier, 1992.
57. A. N. Kolmogorov and S. V. Fomin. *Elements of the Theory of Functions and Functional Analysis*, **1**. 1999.
58. Zouhair Abdessamad, Ilya Kostin, Grigory Panasenko, and Valery P. Smyshlyaev. Memory Effect In Homogenization Of A Viscoelastic Kelvin-

- Voigt Model With Time-Dependent Coefficients. *Mathematical Models and Methods in Applied Sciences*, **19**:1603–1630, September 2009.
59. R. Stavre, G.P. Panasenko, and Y. Sirakov. Asymptotic and numerical modelling of a flow in a thin channel with visco-elastic wall. *Int. J. Multiscale Comput. Engng.*, **5**:473–482, 2007.
60. O. A. Ladyzhenskaya. *The Boundary Value Problems of Mathematical Physics*. Springer, New York, 1985.
61. L. Alaoglu. Weak topologies of normed linear spaces. *Annals of Mathematics*, **41**:252–267, 1940.
62. G. Geymonat, F. Krasucki, and S. Lenci. Mathematical Analysis of a Bonded Joint with a Soft Thin Adhesive. *Mathematics and Mechanics of Solids*, **4**:201–225, June 1999.
63. H. Brezis. *Functional Analysis, Sobolev Spaces and Partial Differential Equations*. Springer New York, New York, NY, 2010.
64. E. G. D'yakonov. Estimation of the Kolmogorov N-widths for certain compacts in the strengthened Sobolev spaces. *Izv. Vyssh. Uchebn. Zaved. Mat.*, **4**:32–50, 1997.
65. M. R. Timerbaev. Spaces with a graph norm and strengthened Sobolev spaces. I. *Izv. Vyssh. Uchebn. Zaved. Mat.*, **5**:55–65, 2003.
66. M. R. Timerbaev. Spaces with a graph norm and strengthened Sobolev spaces. II. *Izv. Vyssh. Uchebn. Zaved. Mat.*, **9**:46–53, 2003.
67. G. Fichera. *Existence Theorems in Elasticity*. Springer-Verlag, Berlin-Heidelberg-New York, 1972.
68. A.M. Ilin and A.R. Danilin. *Asimptoticheskie metody v analize [Asymptotic methods in analysis]*. Fizmatlit Publ., Moscow, 2009.
69. V. V. Jikov, S. M. Kozlov, and O. A. Oleinik. *Homogenization of Differential Operators and Integral Functionals*. Springer Berlin Heidelberg, Berlin, Heidelberg, 1994.

70. G. Papanicolau, A. Bensoussan, and J.-L. Lions. *Asymptotic Analysis for Periodic Structures* 1978 volume. 1978.
71. G. Panasenko. *Multi-scale Modelling for Structures and Composites*. Springer, 2005.
72. A.G. Kolpakov. *Stressed Composite Structures: Homogenized Models for Thin-Walled Nonhomogeneous Structures with Initial Stresses*. Springer Science & Business Media, 2004.
73. S. A. Nazarov. Asymptotic expansion of the solution of the Dirichlet problem for an equation with rapidly oscillating coefficients in a rectangle. (Russian). *Mat. Sb.*, **182**:692–722, 1991.
74. I. S. Malakhova. Boundary value problem for an elliptic equation with rapidly oscillating coefficients in a rectangle. *Computational Mathematics and Mathematical Physics*, **51**:1360–1368, August 2011.
75. J. Orlik. Two-scale homogenization in transmission problems of elasticity with interface jumps. *Applicable Analysis*, **91**:1299–1319, July 2012.
76. A. Braides and Valeria C. Piat. Remarks on the homogenization of connected media. *Nonlinear Analysis: Theory, Methods & Applications*, **22**:391–407, February 1994.
77. P.J. Blanco, M. Discacciati, and A. Quarteroni. Modeling dimensionally-heterogeneous problems: analysis, approximation and applications. *Numer. Math.*, **119**:299–335, 2011.
78. C. D'Angelo, G. Panasenko, and A. Quarteroni. Asymptotic-numerical derivation of the Robin type coupling conditions for the macroscopic pressure at a reservoir-capillaries interface. *Appl. Anal.*, **92**:158–171, 2013.
79. G.P. Panasenko. Method of asymptotic partial decomposition of domain. *Math. Mod. Meth. Appl. Sci.*, **8**:139–156, 1998.
80. G.P. Panasenko. Partial asymptotic decomposition of domain: Navier-Stokes equation in tube structure. *C. R. Acad. Sci. Paris - Ser. IIB - Mec.-Phys.-Astr.*, **326**:893–898, 1998.

81. G. Panasenko. The partial homogenization: continuous and semi-discretized versions. *Math. Mod. Meth. Appl. Sci.*, **17**:1183–1209, 2007.
82. C. D'Angelo and A. Quarteroni. On the coupling of 1D and 3D diffusion-reaction equations: application to tissue perfusion problems. *Math. Mod. Meth. Appl. Sci.*, **18**:1481–1504, 2008.
83. T. Passerini, M.R. De Luca, L. Formaggia, A. Quarteroni, and A. Veneziani. A 3D/1D geometrical multiscale model of cerebral vasculature. *J. Eng. Math.*, **64**:319–330, 2009.
84. G.P. Galdi. *An introduction to the mathematical theory of the Navier-Stokes equations*. Springer-Verlag, New York, 2011.