



HAL
open science

IMPOSSIBILITY RESULTS: FROM GEOMETRY TO ANALYSIS

Davide Crippa

► **To cite this version:**

Davide Crippa. IMPOSSIBILITY RESULTS: FROM GEOMETRY TO ANALYSIS : A study in early modern conceptions of impossibility. History, Philosophy and Sociology of Sciences. Université Paris Diderot Paris 7, 2014. English. NNT: . tel-01098493

HAL Id: tel-01098493

<https://hal.science/tel-01098493>

Submitted on 25 Dec 2014

HAL is a multi-disciplinary open access archive for the deposit and dissemination of scientific research documents, whether they are published or not. The documents may come from teaching and research institutions in France or abroad, or from public or private research centers.

L'archive ouverte pluridisciplinaire **HAL**, est destinée au dépôt et à la diffusion de documents scientifiques de niveau recherche, publiés ou non, émanant des établissements d'enseignement et de recherche français ou étrangers, des laboratoires publics ou privés.

UNIVERSITE PARIS DIDEROT (PARIS 7)
SORBONNE PARIS CITE

ECOLE DOCTORALE: Savoirs Scientifiques, Epistémologie, Histoire des Sciences et
Didactique des disciplines

DOCTORAT: Epistémologie et Histoire des Sciences

DAVIDE CRIPPA

**IMPOSSIBILITY RESULTS: FROM GEOMETRY TO
ANALYSIS**

A study in early modern conceptions of impossibility

**RESULTATS D'IMPOSSIBILITE: DE LA GEOMETRIE A
L'ANALYSE**

Une étude de résultats classiques d'impossibilité

Thèse dirigée par: Marco PANZA

Soutenue le: 14 Octobre 2014

Jury:

Andrew Arana

Abel Lassalle Casanave

Jesper Lützen (rapporteur)

David Rabouin

Vincenzo de Risi (rapporteur)

Jean-Jacques Szczeciniarz

Alla memoria di mio padre. A mia madre.

Contents

Preface	9
1 General introduction	14
1.1 The theme of my study	14
1.2 A difficult context	16
1.3 Types of impossibility arguments	20
1.3.1 An ancient example	20
1.3.2 Impossibility in the theory versus impossibility in the meta-theory	21
1.4 Impossibility statements as meta-statements	26
1.4.1 The unsettled nature of the circle-squaring problem	30
1.5 Impossibility results in early modern geometry	39
2 Problem solving techniques in Ancient geometry	44
2.1 Introduction	44
2.2 Pappus' division of problems into three kinds	52
2.2.1 A conjecture about the origin of Pappus' classification of problems	57
2.2.2 Normative aspects in Pappus' classification	60
2.3 Curves and problems of the third kind	66
2.3.1 The conchoid	66
2.3.2 The Quadratrix	68
2.3.3 The Archimedean spiral	73
2.3.4 The Apollonian helix	75
2.4 Problems from the third kind of geometry	78
2.4.1 General Angle Division (<i>Collection</i> , IV, proposition 35)	78
2.4.2 Problems related to the general angle division	82
2.5 The rectification problem	82

2.5.1	The rectification of the circumference via quadratrix (Pappus, <i>Collection</i> , IV, proposition 27)	83
2.5.2	The converse problem: to construct a circumference equal to a given segment	88
2.5.3	Rectification through the spiral (Archimedes, <i>On Spiral lines</i> , prop. XVIII)	89
2.6	On the quadrature of the circle	95
3	The geometry of René Descartes	100
3.0.1	Descartes' geometry and its methodological presuppositions	100
3.0.2	Descartes' early methodology of problem solving	103
3.1	Analysis and Synthesis in Descartes' geometry	113
3.1.1	Cartesian analysis as transconfigurational analysis	113
3.1.2	The constitution of the algebra of segments	126
3.1.3	The construction of the 'four figures'	131
3.2	Descartes' construal of geometricity in 1637	133
3.2.1	Euclidean restrictions reconsidered	133
3.2.2	Early instances of geometrical linkages	146
3.2.3	The determinative character of cartesian algebra	148
4	Simplicity in Descartes' geometry	155
4.1	Introduction	155
4.2	Simplicity in early modern geometry	157
4.3	Classifications of curves and problems	160
4.3.1	Ancient and modern classifications	160
4.3.2	A classification of curves	161
4.3.3	A Classification of problems	167
4.4	Construction of third and fourth degree equations	173
4.4.1	Construction of a cubic equation	175
4.4.2	The insertion of two mean proportionals	179
4.5	Easiness versus simplicity	183
4.5.1	Two solutions compared	183
4.5.2	Easiness, simplicity and the algebraic ordering of curves	186
4.6	Impossibility and the interpretation of Pappus' norm	203
4.6.1	Impossibility arguments in <i>La Géométrie</i>	203
4.6.2	A case for unrigorous reasoning	209

4.6.3	Impossibility results as metastatements	214
4.6.4	The legacy of the cartesian programme: simplicity at stake	215
5	Mechanical curves in Descartes' geometry	221
5.1	Mechanical curves in Descartes' geometry	221
5.2	On Geometrical and Mechanical constructions	227
5.2.1	Constructions by means of twisted lines or strings	229
5.2.2	Construction of the spiral (Schwenter, Huygens)	231
5.2.3	Pointwise construction of mechanical curves	234
5.3	Descartes' appraisal of string-based mechanisms and pointwise constructions	247
5.4	Specification by genesis and specification by property: the case of mechanical curves	255
6	Impossible problems in cartesian geometry	266
6.1	On the cartesian distinction between possible and impossible problems	266
6.2	Impossibility claims as a meta-statements	272
6.3	On the significance of early rectifications for Descartes' meta-statement	276
6.4	Problems of quadratures and the problem of area	288
7	James Gregory's Vera Circuli Quadratura	296
7.1	Introduction: the quadrature of the circle	296
7.2	The controversy between James Gregory and Christiaan Huygens	303
7.3	Analyzing the quadrature of the circle	307
7.3.1	The aims of analysis	307
7.3.2	Introducing convergent sequences	314
7.3.3	The convergence of the double sequence	321
7.3.4	Computing the <i>terminatio</i>	329
7.4	An argument of impossibility	334
7.5	Reception and criticism of Gregory's impossibility argument	342
7.6	Conclusions	354
7.6.1	Bibliographical note	365
8	The arithmetical quadrature of the circle	367
8.1	Introduction	367
8.1.1	The manuscript of the <i>De quadratura arithmetica</i>	368
8.1.2	Leibniz's acquaintance and study of Gregory's works	370
8.2	The arithmetical quadrature of the circle, its main results	373

8.2.1	Looking backward onto Leibniz's quadrature of the central conic sections	373
8.2.2	Towards the arithmetical quadrature of the circle: the transmutation theorem	376
8.2.3	Towards the arithmetical quadrature of the circle: the generation of the 'anonymous' curve	381
8.3	A digression: Mercator-Wallis technique for the quadrature of the hyperbola	385
8.4	Leibniz's arithmetical quadrature of 1674-'75	396
8.4.1	Extending Wallis-Mercator technique	396
8.4.2	The rectification of a circular arc	401
8.4.3	Leibniz's fictionalist stance	403
8.5	The quadrature of the circle in numbers	406
8.5.1	Leibniz's alternate series for $\frac{\pi}{4}$	406
8.5.2	Oldenburg's objections and the classification of quadratures	414
8.6	The impossibility of giving a universal quadrature of the circle	422
8.6.1	Leibniz's criticism of Gregory's arguments	422
8.7	An impossibility argument	428
8.7.1	Universal and particular quadratures	428
8.7.2	The impossibility of the universal quadrature	430
8.7.3	The impossibility of finding a general quadrature of the hyperbola	438
8.8	Underdeveloped parts in Leibniz's impossibility argument	440
8.9	The transcendental nature of curves	445
8.10	Conclusions	450
8.10.1	On the limits of cartesian geometry	450
8.10.2	The constitution of transcendental mathematics and Leibniz's new calculus	459
8.10.3	Appendix: primary sources	464
9	Epilogue	466
9.1	A survey of early-modern impossibility results	466
9.2	The structure of early modern impossibility results	470
9.2.1	The role of algebra in XVIIth century	470
9.2.2	Algebraic proofs of impossibility theorems	474
9.2.3	Early modern constructions and constructibility	476
9.2.4	From the constructive paradigm to the conceptual paradigm	479
9.3	Impossibility arguments as answers to metatheoretical questions	483

Preface: capturing the unicorn

... *the fence inside which we hope to have enclosed what may appear as a possible, living creature.*
O. Neugebauer, *The Exact Sciences in Antiquity*, p. 177.

Otto Neugebauer once recalled, in his masterpiece *The exact Sciences in Antiquity*, that his endeavour in restoring the mathematics of the past had a simile in the tale of the unicorn, which ended with the miraculous animal captured in a fence and gracefully resigned to his fate.

In this dissertation, I have also erected, out of pieces of evidence, conjectures and indirect testimonies, an enclosure in order to capture an elusive but (I think) living subject of research. This subject is provided by the theme of impossibility results in classical and early modern mathematics.

I started the inquiry which led to this dissertation out of the following, perhaps naive observation: all the famous impossibility results in geometry (namely, the impossibility of duplicating the cube, trisecting an angle or squaring the circle by ruler and compass) are proved by appealing to a rather sophisticated algebraic machinery. Why mathematicians had turned to algebra in order to prove geometric impossibility results, and what makes algebra such a powerful resource that it could prove the impossibility of solving certain problems in geometry, apparently unprovable by geometric means only?

My original questioning was as much interesting to me as it was broad, and perhaps unfit for a discussion within a single dissertation. I then decided to develop my inquiry mainly from a historical viewpoint, and turned to what I considered one of the first examples of algebraic thinking in geometry, namely, Descartes' epoch-making *La Géométrie*. I read this text wondering whether it might contain any deliberation on impossibility.

I found out that Descartes was concerned with the type of impossibilities I was looking for, although his arguments were at first sight of difficult understanding. In order to enlighten Descartes' ideas on impossibility, I enlarged my interest to XVIIth century geometry, and explored whether considerations about impossibility emerged elsewhere too.

The results of this study are contained in this dissertation. This dissertation is composed of two main parts. The first part (chapters 1 - 5) spans from antiquity to Descartes' *Géométrie* (1637) but it is mainly focused on the latter work. The aim of this part is to explore, in a critical manner, the historical setting in which early modern impossibility results were formulated, with a particular attention for certain salient and problematic episodes for the historian of mathematics (for instance, the problem of understanding which rational criterion guided Descartes in order to distinguish geometrical from mechanical curves, and to choose the simplest solution for a problem at hand). These episodes are related to the main focus of this dissertation, namely, impossibility results.

The second part of this study (chapters 6 - 9) covers two salient historical cases during the second half of XVIIth century geometry, namely James Gregory's and G. W. Leibniz's attempts to prove the impossibility of squaring the central conic sections. The connection between the two parts is given by the legacy of *La Géométrie*. In particular, this text offered a model in order to formulate, and tentatively prove impossibility results in geometry.

In pursuing the theme of impossibility in early modern geometry, I left aside other possible contexts in which impossibility in mathematics might have emerged, as in connection with irrational, negative and impossible numbers. This dissertation is not about these issues. This choice has obviously influenced the mathematical results examined in this dissertation, the context investigated and the conclusions drawn.

On the other hand, this dissertation is neither about a reconstruction of the historical setting in which early modern impossibility results emerged. However, in studying impossibility results I was guided by a specific concern for mathematical practices. I was indeed interested in what motivated the formulation of certain impossibility results, in the techniques mathematicians had employed in order to argue for the impossibility of solving a certain problem, and how did these impossibility results differ from actual impossibility theorems, both from the point of view of the arguments adopted and from the point of view of their role and importance in their respective theories.

In order to explore these themes, a study of certain mathematical theories and achievements in their own terms seemed to me unavoidable. For this reason, I devoted large sections of this work to present and discuss in more general terms some of the mathematical advances brought about by Descartes, James Gregory and Leibniz, among others, as far as I judged them important for the theme of my research.

I consider my research on impossibility by no means finished. In order to have a more complete description and a more satisfying understanding of early modern impossibility results, the issues discussed in this dissertation should be deepened. An inquiry about how other prominent XVIIth century mathematicians, besides those I have discussed in this study, conceived and treated impossibilities in geometry (Newton and Wallis, for instance), and how new impossibilities emerged in the second half of XVIIth century and in XVIIIth century with the onset of Euler's analysis are among possible, future investigations.

Salvador de Bahia, 20 August 2014.

Acknowledgments

I would like to thank, in the first stance, my advisor, Marco Panza. Under his guidance and help I could write this dissertation. Even when (alas!) I departed from the original plans and took untrodden paths, unsure whether they might lead somewhere, he closely followed my exploration, encouraged me to pursue my own ideas and corrected my technical and methodological mistakes. Most importantly, Marco taught me a style of doing research in the field of history and philosophy of mathematics, that I have suited to my own sensibility and interests. This study is the result of his teaching.

I would also like to thank Vincenzo de Risi. Working in his group at *Max Planck Institut für Wissenschaftsgeschichte* was a great opportunity both for my personal growth and for the direction taken by my research. In particular, Vincenzo gave me helpful and attentive comments on previous drafts of this dissertation. Together with Marco, Vincenzo also taught me a style of doing research that I have interpreted and suited to my own investigations. I also acknowledge, among my colleagues at Max Planck: Angela Axworthy, Jacqueline Feke, Eduardo Giovannini, Tal Glazer, Tzuchien Tho, Henry Zepeda.

I did my Phd in Paris, at SPHERE (Univ. Paris 7). Thanks to the activities of the *laboratoire*, I could take advantage of fruitful conversations with Carlos Alvarez, Andy Arana, Karine Chemla, Mic Detlefsen, Massimo Galuzzi, Sébastien Gandon, Elias Fuentes Guillén, Niccoló Guicciardini, Paolo Mancosu, Kenneth Manders, Sébastien Maronne, John Mumma, Alberto Naibo, Mattia Petrolo, David Rabouin, Ken Saito, Jean-Jacques Szczeciniarz, Sean Walsh. I thank all of them for many insights and ideas, that I have presented and developed in this work.

I would like to thank, in particular, Karine Chemla, David Rabouin and Marie-José Durand Richard. I co-organized with them several workshops, and had the opportunity to invite several outstanding scholars. In particular, I could invite Jesper Lützen, whose work on impossibility has represented a model for my own work. Together with Jesper Lützen, I would like to thank Leo Corry and Henrik Sørensen.

While in Berlin, I had the opportunity to work under the guidance of prof. Eberhardt Knobloch, at the *Akademie der Wissenschaften*. Thanks to his patience and scholarship I could venture into the labyrinth of Leibniz's manuscripts. This was a veritable intellectual adventure, that I continued, on few occasions, in Hannover, at the *Leibniz Archiv*, where Siegmund Probst shared his discoveries with me, with sympathy and generosity, and helped me finding my way into the meanders of Leibniz's mathematics. I also thank dr. Michael Kempe for his assistance and availability.

Exchanges with Michael Otte, both by email and by conversation, levelled many philosophical questions to which I tried to answer in this dissertation.

Logically delightful was my visit to the department of Mathematics of Bristol University, where I discussed with Andrey Bovykin. Philosophically delightful was also my stay

in the department of Philosophy at the university of York, where I had some useful discussions with Michael Beaney and Bob Clark.

For several, both personal and academic reasons, parts of this dissertation were written in Brazil. I especially acknowledge Walter Carnielli, his colleagues and students for their warm welcoming at the CLE (UNICAMP) and for the insightful exchanges. I acknowledge Eduardo Barra, for my stay in Curitiba (UFPR), and Luiz Carlos Pereira, in Rio de Janeiro (PUC-UFRJ).

This dissertation was also concluded in Brazil, at the Federal University of Salvador de Bahia (UFBA), where I spent two months, in the cadre of a project on "Preuve, démonstration et représentation", funded by the CAPES-COFECUB. I would like to thank Abel Lassalle Casanave, with whom I have been working through the final steps of my dissertation.

I thank Daniel Nethery for having read parts of this dissertation and corrected my too clumsy English.

Finally, I would like to acknowledge my family and all those friends whose love and affection I may have neglected for a flickering and wayward dialogue with men departed so many centuries ago. I hope they can forgive me, my reckless passions, my surrendering to ambitions.

Chapter 1

General introduction

1.1 The theme of my study

In this dissertation, I will discuss impossibility results in early modern geometry.¹ More specifically, I will focus on the period between the beginning of XVIIth century and the second half of the 1670s, and I will examine some of the arguments advanced by geometers in order to justify the impossibility of solving a problem by prescribed methods. I will consider, in particular, the impossibility of solving by certain methods the three ‘classic’ construction problems of antiquity: the quadrature of the circle, the trisection of an angle, and the duplication of the cube (or the problem of inserting two mean proportionals between two given segments, to which the former problem can be reduced).²

It is generally acknowledged that the impossibility of solving those classic construction problems was not rigorously proved until the 19th century. Moreover, it is also taken for granted that the forms ultimately worked out in the end of 19th century, which were transmitted to the present, depended on methods unavailable to early modern geometers, and on an underlying conception of geometry almost foreign to its predecessors.

The impossibility of solving the duplication of the cube and the trisection of a general angle by straightedge and compass were firstly proved by Pierre Wantzel (1814-1848) in

¹The term ‘early modern geometry’ will be employed from now on to designate the collection of texts, but also the results, problems and related solving methods that occupied mathematical research between the renaissance and the enlightenment, from 1550 ca. to 1750 ca.

²For a classical survey of the ancient discussions about these problems, see Heath [1981], Becker [1957] (p. 74ff. and p. 93ff.) and Enriques [1912] (in particular the article by L. Conti contained in this volume).

1837.³ On the other hand, the impossibility of squaring the circle was proved for the first time by Ferdinand Lindemann (1852-1939), in 1882, in a very strong way: in fact he formulated the first proof of the transcendentality of π , which implies the impossibility of squaring the circle with straightedge and compass, and more generally with algebraic curves.⁴

At their ground, all these impossibility proofs rely on the possibility of treating the existence of mathematical objects in an abstract, indirect way. Developments of algebra, indeed, offered an adequate machinery in order to model geometric contexts, and therefore to handle questions about the existence of an object in a theory (for instance, a certain geometric object in elementary Euclid's geometry) without requiring its exhibition through a construction. It is well known that, relying on the same (or very similar) resources employed by the aforementioned mathematicians, one can prove that a regular polygon with 257 sides exists in Euclid's Plane geometry, by proving its constructability through ruler and compass, even if this polygon has not been constructed, i.e., even if its existence has not been proved through an effective construction.⁵

A geometric impossibility theorem can be conceived as the negative counterpart of a theorem of constructability. We might envisage it as a theorem proving that a certain object (namely a problem) does not possess the property of being constructable by prescribed instruments. The property at stake in such a proof is constructability, which is understood and treated as a property on a par with other properties that may be attributed to a mathematical (in this case a geometrical) object.

But mathematicians ruled against the possibility of solving the previously mentioned problems well before their impossibility were actually proved, and within contexts or within mathematical practices where indirect proofs of existence were in general not allowed. Thus Descartes pronounced, as early as 1637, against the possibility of duplicating the cube and trisecting the angle by plane means (i.e. straight-line-and-circle constructions). For what concerns the quadrature of the circle, M. Jacob has convincingly argued in her Jacob [2005] that the problem was declared 'unsolvable' out of 'an authoritarian decision of enlightenment'.

³Wantzel [1837]. *Cf.* in particular the insightful study in Lützen [2009].

⁴See Lindemann [1882]. One year later, in 1893, Hilbert simplified Lindemann's proof (*cf.* Klein [1894], p. 53).

⁵The original proof of constructibility of this polygon is contained in Gauss [1801], § VIII.

As I will discuss in this study, the belief in the unsolvability of one problem by given methods was not only dictated by the authority, nor merely by repeated unsuccesses in trying to solve it. The conviction on the impossibility of squaring the circle, duplicating the cube and trisecting the angle by ruler and compass was in fact grounded on arguments which, although they appeared either flawed or lacking in rigour if examined from our viewpoint, enjoyed some circulation during the second half of XVIIth century, and were studied and discussed. In particular, my examination will consider some of the earliest instances of impossibility results and correlated arguments given by René Descartes (1596-1650) in *La Géométrie* (1637), then an important impossibility result about the quadrature of the circle by algebraic or analytical methods, argued by James Gregory (1638-1675) in his *Vera Circuli et Hyperbolae Quadratura* (1667), and finally, the same impossibility result discussed by G.W. Leibniz (1646-1716), in an unpublished work, which had however a vast resonance among contemporary mathematicians: *De quadratura arithmetica circuli ellipseos et hyperbolae cujus corollarium est trigonometria sine tabulis* (ultimated in 1676).

1.2 A difficult context

My choice to privilege XVIIth century geometry might appear infelicitous. In the early modern period, in fact, geometry was a constructive enterprise, and it is by no means clear which status might be attributed to impossibility results and arguments in such a framework and within early modern mathematical practice.

By stressing the constructive character of early modern geometry, I refer foremost to an aspect of the mathematical practice, which has been defined as the "classical conception of proof and knowledge" in mathematics.⁶

According to this conception, problems and theorems, namely the fundamental types of propositions, or modes of argumentation, in classical and early modern geometry possessed an undeniable constructive component. Let us consider one of the standard and most influential accounts of the distinction between these geometric propositions, namely Proclus' Commentary on the first Book of Euclid's *Elements*:⁷

⁶See Detlefsen [2005].

⁷Proclus' text, written in the fifth century A.D., was available in print since 1533. The latin translation (*Procli Diadochi Lycii in primum Euclidis elementorum librum commentariorum ad universam mathematicam disciplinam principium eruditionis tradentium libri IV*) appeared in 1560, and was made by F. Barozzi (*cf.* Proclus [1948], pp. xxiff.). See also Bowen [1983] for a reconstruction of hellenistic

The propositions that follow from the first principles he [Euclid] divides into problems and theorems, the former including the construction of figures, the division of them into sections, subtractions from and additions to them, and in general the characters that result from such procedures, and the latter concerned with demonstrating inherent properties belonging to each figure.⁸

According to Proclus, who drew his conceptions of problems and theorems on the tradition of Euclid's geometry and on other traditions, not preserved to us,⁹ problems involve the construction of a figure in the plane from some given or known figures, or the performing of some operations on a given configuration of geometric entities, and concern the properties which result thereby, whereas theorems show the intrinsic properties of given geometric figures.

This very idea is developed in another passage of Proclus [1992]:

[geometry] calls 'problems' those propositions whose aim is to produce, bring into view, or construct what in a sense does not exist, and 'theorems' those whose purpose is to see, identify and demonstrate the existence or nonexistence of an attribute. Problems require us to construct a figure, or set it at a place, or apply it to another, or inscribe it or circumscribe it about another, or fit it upon or bring it into contact with another, and the like; theorems endeavor to grasp firmly and bind fast by demonstration the attributes and inherent properties belonging to the objects that are the subject matter of geometry.¹⁰

Hence, problems involve a construction in order to pass from something given to what is sought for in the givens. An undeniable constructive component is also involved, in Proclus' view, in the conception of theorem. Even if Proclus states that most theorems do not require an explicit construction,¹¹ yet they can be characterized as well by something 'given' in an 'enunciation' and something sought for. The given figure or object must be present to our visual inspection (let us recall that the purpose of theorems is to "see,

views on problems and theorems.

⁸Proclus [1992], p. 63.

⁹Proclus surveys several positions in the tradition of Greek mathematics, on the definitions of problems and theorems, that I will not explore here: *cf.* Proclus [1992], p. 65-66.

¹⁰Proclus [1992], p. 157.

¹¹See, for instance, Proclus [1992], p. 159.

identify and demonstrate"), if not as a physical diagram, at least as a representation in the imagination, I surmise.

In another passage of the Commentary, Proclus explains more plainly that the figure of which we want to prove certain attributes should be made present to our contemplation by means of a construction, as it is the case in the ordering of the first proposition of Euclid's *Elements*. In fact, the first theorem of Euclid's *Elements* (namely, *El.*, I, 4) is preceded by three problems, in which the subject matter of the theorem is constructed or exhibited:

The propositions before it have all been problems ... our geometer follows up these problems with this first theorem. ... For unless he had previously shown the existence of triangles and their mode of construction, how could he discourse about their essential properties and the equality of their angles and sides? And how could he have assumed sides equal to sides and straight lines equal to other straight lines unless he had worked these out in the preceding problems and devised a method by which equal lines can be discovered? ... It is to forestall such objections that the author of the *Elements* has given us the construction of triangles. ... These propositions are rightly preliminary to the theorem...¹²

This view about the primacy of constructions was possibly contested in classical antiquity, as it can be gleaned through Proclus Commentary,¹³ but it exerted a tangible influence

¹²Proclus [1992], p. 182-183.

¹³I am referring, in particular, to the dispute, related by Proclus, risen in the Academy, between the followers of Speusippus and those of Maenechmus (See Proclus [1992], p. 63ff.). According to the former (and to his followers), the word 'theorem' is more appropriate than 'problem' in order to denote arguments in geometry, since this science treats of eternal objects, for which it is not appropriate to use the language of construction. According to the school of Speusippus, constructions do not produce geometric objects, but they offer means for knowing such (eternal) geometric objects. On the contrary, Maenechmus, and his school, defended the thesis that all geometric inquiries are problems, which can be further subdivided in two types. On one hand, problems may serve to exhibit a figure by construction; on the other, they may be employed to investigate the properties of a given object. Proclus tries to harmonize this view, remarking that the followers of Speusippus are right in claiming that geometry does not deal (unlike mechanics) with concrete, perceptible objects, which undergo changes and motion, and that the followers of Maenechmus are right too in asserting the constructive aspect of geometric propositions: "in going forth into this matter and shaping it, our ideas are plausibly said to resemble acts of production; for the movement of our thought in projecting its own ideas is a production (...) of the figures in our imagination and of their properties" (Proclus [1992], p. 64). Hence, Proclus insists, geometers are legitimated in talking about construction and dissection of figures, provided they understand that these changes occur in the imagination, whereas the "contents of our understanding" remain immutable, thus granting geometry the status of science (Proclus [1992], p. 64).

over early modern geometers, as it is attested both by the activity of the mathematicians, and by their methodological pronouncements.¹⁴

As an example of the latter, let us consider how Clavius, one of the leading figures of renaissance mathematics, who exerted a long-standing influence over the subsequent century too, interpreted the ancient distinction into problems and theorems in terms of a distinction between types of demonstration: "All demonstrations of mathematicians are divided by ancients into problems and theorems. A demonstration that demands that something be constructed and teaches how to construct it they call a problem (*problema vocant eam demonstrationem, quae iubet an docet aliquid constituere*) . . . but they call the demonstration that examines only some aspects or property of one or several magnitudes at once a theorem (*Theorema aut appellatur eam demonstrationem, quae solum passionem aliquam, proprietatemve unius vel plurium simul quantitatum perscrutatum*)."¹⁵ As an example of theorem, Clavius chooses the following: "in every triangle, the three angles are equal to two right angles", because "it does not prescribe to, not teach how to construct a triangle, or anything else, but contemplates merely this property of a constructed (*constituti*) triangle, namely that its angles [i.e. their sum] are equal to two right angles".¹⁶

The kinship between Clavius' and Proclus' definitions eloquently points towards a direct influence of the latter over Clavius' reflection. It is, moreover, the mark of a deeper influence on the structure of early modern mathematics, since geometers continued to rely on Proclus' account of the distinction between problems and theorems throughout XVIIth century (for more seventeenth century examples, see chapter 6, p. 6.2).

In this setting, which constitutes the background of ancient and early modern geometry, the principal types of inquiry consisted either in the construction of a geometric object (for instance, a figure) from given ones, according to certain clauses, or in proving that a figure thus constructed, or given, possessed some properties. Hence, it is at first sight

¹⁴The constructive character of ancient mathematics was emphasized by Zeuthen, in his famous paper Zeuthen [1896]. Zeuthen's thesis can be briefly resumed: constructions serve, in ancient geometry, as proof of existence of the constructed figures. The historical plausibility of this thesis has been criticized, notably by W. Knorr (Knorr [1983]). I am not endorsing, in this study, the thesis that ancient geometers consciously endorsed a constructivist position towards existential claims, but that in the structure of ancient and early modern geometry existential claims were established by exhibiting geometric objects through constructions, or by assuming them as given, on the ground of intuitive properties of geometric figures, like continuity.

¹⁵*Cf.* Euclid [1589], p. 23, trad. in Jesseph [1999], p. 21.

¹⁶*Cf.* Euclid [1589], p. 24

unclear which logical status might be attributed to negative, impossibility arguments, like those purporting to show that a certain construction cannot be accomplished by selected tools.

1.3 Types of impossibility arguments

1.3.1 An ancient example

It should be pointed out that impossibility proofs were not completely extraneous to the context of ancient and early modern geometry. Indirect proofs, namely proofs using *reductio ad absurdum*, can be in fact considered impossibility proofs, in the following, trivial sense: any theorem p can be proved by proving that its negation is impossible. This viewpoint is contemplated by Proclus, who comments upon *reductio* in these terms:

Every reduction to impossibility takes the contradictory of what it intends to prove and from this as a hypothesis proceeds until it encounters something admitted to be absurd and, by thus destroying its hypothesis, confirms the proposition it set out to establish.¹⁷

Reductio is a standard argumentative pattern in Euclid's *Elements*. In order to understand it through a concrete example, let us consider *El.* 1, proposition 27:

If a straight line falling on two straight lines make the alternate angles equal to each other, the straight lines will be parallel to one another.¹⁸

Euclid claims that given two straight lines AB and CD , and a transversal EF , if EF forms alternate equal angles AEF , EFD , then the straight lines AB and CD are parallel.

Euclid argues indirectly, by supposing that straight lines AB and CD are not parallel. If this is so, then they will concur in a point, lying either on one or the other side with respect to the transversal. It is assumed that they meet, on a given side, in a point G . This point, together with the intersection points E and F can form triangle EFG . But such a triangle will have, by hypothesis, one exterior angle (namely AEF) equal to the opposite interior angle (namely EFD): which is impossible, in virtue of *El.* I, 16: "In any triangle, if one of the sides be produced, the exterior angle is greater than either

¹⁷Proclus [1992], p. 198.

¹⁸I refer to the translation in Heath [1956 (first edition 1908)].

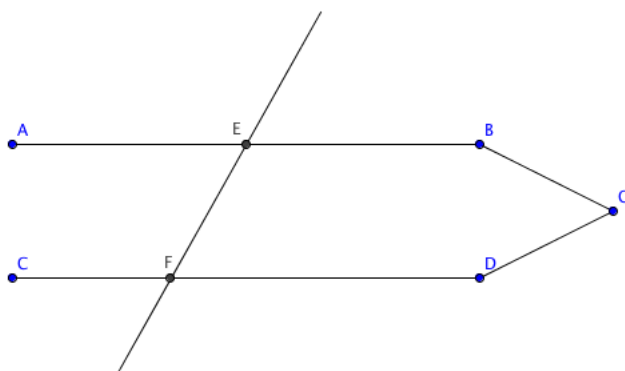
Figure 1.3.1: *Elements*, I, 27.

of the interior and opposite angles".¹⁹ Once discovered this contradiction, Euclid can conclude by denying the thesis that the straight lines will meet. Therefore AB and CD are parallel. According to Euclid's definition, in fact: "parallel straight lines are straight lines which, being in the same place and being produced indefinitely in both directions, do not meet one another in either direction" (*El.*, I, df. 23).

This theorem is proved by assuming an impossible configuration: a triangle in which an external angle is equal to the opposite, internal one. Such a triangle is impossible, in so far it possesses properties which are inconsistent or incompatible with other properties that have been proved to hold true of this figure.

Impossibility arguments like the one deployed in *El.* I, 27, occur in *reductio* modes of argumentation, which are common in pre-modern mathematics. They can be considered 'local' impossibility arguments, at least in the context of Euclid's first six Books of the *Elements*: their aim is to prove theorems about given or constructed figures.

1.3.2 Impossibility in the theory versus impossibility in the meta-theory

Contriving a little Euclid's text, proposition 27 can be interpreted as stating that it is impossible to construct the intersection point between a segment CD produced and a

¹⁹Eng. tr. in Heath [1956 (first edition 1908)].

segment AB produced, such that they form equal alternate angles with respect to a transversal EF . In other words, *El.* I, 27 can be read as an impossibility theorem, or a theorem of non-existence, since it states that an intersection point between straight lines which obey the conditions specified in the protasis does not exist.

Another, well known example of such an impossibility proof is the proof of the incommensurability between the side of a square and its diagonal. Let us recall that, according to Aristotle, mathematicians: "prove that the diagonal of a square is incommensurable with its sides by showing that, if it is assumed to be commensurable, odd numbers will be equal to even" (Szabó [1978], p. 214). Adopting the interpretation advanced by Becker and reported in Szabó's account, on which I refer here, this argument leads from the assumption that the side of a square is commensurable with its diagonal to the conclusion that the side can be associated to a number both even and odd. From this conclusion, a contradiction results (Szabó [1978], p. 215).²⁰

However, an important difference can be singled out between impossibility results occurring in indirect proofs in geometry, like in *El.* I 27 above, and impossibility claims concerning the non constructability of a certain object by prescribed means. Let us consider, for instance, the impossibility of constructing, by ruler and compass, a cube whose volume is double of a given cube. The claim to the unsolvability of this problem does not entail that the object we wish to construct (namely, a cube with volume double of a given cube) involves a contradiction, but that the tools demanded for its construction (in the case at point, the ruler and compass) are insufficient with respect to the task set at the beginning. One could certainly assume, on the ground of an intuition of continuity, the existence of a double cube without contradiction, and employ more 'powerful' methods than the ruler and the compass in order to obtain the required solution (several examples of such methods, available to Greek geometers, will be discussed in the next chapter). We can call this kind of impossibility result 'conditional' impossibility result, because the impossibility depends on the use of particular means to solve the problem.

On the contrary, proving that the intersection point between two straight lines, forming alternate equal angles with the same transversal, cannot be constructed (*El.*, I, 27) implies that such a point cannot be constructed *tout court*, independently from the methods employed, because its existence would imply an impossible configuration. These impossibility results can be called 'absolute impossibilities'.

²⁰See also Gardies [1991], p. 33 in particular.

Did classical geometric reasoning could countenance also the conditional impossibility results that I will address in this study, like the impossibility of solving the problem of trisecting an angle, duplicating the cube or squaring the circle by a given set of instruments, e.g. ruler and compass? In other words, did classical geometry, conceived as a constructive enterprise, possess the resources in order to study constructibility and therefore and prove conditional impossibility results?

In order to venture an answer, let us sharpen, by reverting to a more modern framework, the distinction between absolute impossibility proofs and conditional impossibility proofs. In order to capture the gist of this distinction, I shall expound, on broad strokes, an example of the latter kind of impossibility result, namely the proof that a cube cannot be duplicated by ruler and compass.

Although examples of this impossibility proof are commonplace in modern expository textbooks in algebra, I shall follow the structure of the classical account offered in Smorynski [2007] (p. 87-131) because it relies solely on considerations which do not go beyond the scope of elementary algebra and geometry. Even in this case, I shall take for granted few theorems whose proofs are not requisite for the sake of my argument.

My starting point will be a clarification of the meaning attached to the expressions ‘construction by ruler’, ‘construction by compass’, that I have so far used on an intuitive base. Let us thus call a ‘configuration’ a finite collection \mathcal{C} of points, segments and circles lying in the plane. Let us define a ‘curve’ in \mathcal{C} to be either a segment or a circle. Let us call a ‘construction step’ one of the three following operations:²¹

- (ruler) Given two distinct points A and B belonging to \mathcal{C} , trace the line AB which connects A and B , and add AB to the configuration \mathcal{C} .
- (compass) Given two distinct points A and B belonging to \mathcal{C} , and a distinct point O in \mathcal{C} , trace the circle with center in O and radius equal to AB (namely the line joining A and B), and add the circle to the configuration \mathcal{C} .
- (intersection) Given two distinct curves in \mathcal{C} , pick one point common to both curves, and add it to the configuration \mathcal{C} .

²¹See for instance H. et al. [1974], p. 199.

Next we can state that a point, line or circle is ‘constructible’ by ruler and compass from \mathcal{C} , if it can be obtained from \mathcal{C} after applying a finite number of constructions steps. Let A and B two distinct point in the plane P . The first two operations just defined license to add to the configuration both the line joining A and B , and the circle with center in A and radius AB .

We can now ask the question standing at the core of the cube duplication problem: is it always possible to construct a point C such that the cube built on AC is the double of the cube built on AB ?

An answer can be given by going through two main steps.²² The first step requires to endow our plane with a system of coordinates over the reals. The notion of ruler-and-compass constructability can be then characterized in algebraic terms, by relying on the following:

Lemma A basic configuration $\{A, B\}$ is given in the real cartesian plane, such that $A(0, 0)$, $B(0, 1)$. Then it is possible to construct a point $Q(\alpha, \beta)$ by ruler and compass if and only if α and β can be obtained from A and B by arithmetic operations $(+, -, \div, \cdot)$ and by the solution of a finite number of successive linear and quadratic equations, involving the square roots of positive real numbers.

A number α is called ‘constructible’ if it can be obtained from rational numbers, by a finite sequence of arithmetic operations $(+, -, \div, \cdot)$ and successive extractions of square roots. Consequently, a point is called ‘constructible’ if its coordinates, in a real cartesian plane, are constructible numbers. I point out that the above lemma allows us to characterize constructability, introduced as a purely geometric notion, in algebraic terms.

I will assume the above lemma,²³ and confine myself to remarking that this lemma offers an algebraic criterion to decide the general possibility of a straightedge and compass construction. Hence, in the real cartesian plane, the question whether a point $C(x, 0)$ can be constructed by ruler and compass, in such a way that the cube built on AC is the double of the cube with edge AB , where A has coordinates $(0, 0)$ and B coordinates $(1, 0)$, boils down to inquire whether the abscissa x , satisfying the equation: $x^3 = 2$, is constructible.

²²My presentation is indebted to Laugwitz [1962].

²³The proof is elementary: see Hartshorne [2000] p. 122.

This is the second step of our proof. A negative answer will follow from this other:

Lemma Consider the polynomial of the form: $P(X) = X^3 + aX^2 + bX + c$, with $a, b, c \in \mathbb{Q}$. If the equation $P(x) = 0$ has a constructible solution, then P has a rational solution as well.²⁴

The equation $x^3 - 2 = 0$ is a special case of $P(x) = 0$ (for $a = 0$, $b = 0$ and $c = -2$). It can be proved that the equation: $x^3 - 2 = 0$ has no rational solutions.²⁵ In virtue of the preceding lemma, the equation has no constructible solutions as well, so that point C cannot be constructed by ruler and compass from the original configuration $\{A, B\}$.

Looking at today treatments of impossibility proofs, the translation of a statement in a given theory (i.e plane constructive geometry) into another (i.e. algebra or analysis) seems a requisite condition for proving conditional impossibility claims. Michael Otte correctly and precisely observes in Otte [2003]:

Impossibility proofs (...) are not only indirect proofs but also depend on the choice of a certain representation. In order to prove, for instance, that the doubling of the cube is impossible, one has to represent the constructible numbers to show that the third root of 2 is not a constructible number.²⁶

In the above passage, Otte only recalls the proof of the impossibility of duplicating the cube by ruler-and-compass constructions, but similar examples will hold for the other classical construction problems.

In the context of today mathematical knowledge,²⁷ we thus recognize that ‘the choice of a certain representation’, from which impossibility proofs in geometric problem solving depend, requires the systematic translation of a mathematical theory into another mathematical theory, for example a translation from geometry to algebra or analysis.

²⁴A fully-fledged proof can be found in Smorynski [2007], p. 92.

²⁵Hartshorne [2000], p. 243. Let us suppose that the polynomial: $P(x) = x^3 - 2$ could be factored over \mathbb{Q} . Then it will have at least a linear factor, so it will have a rational root. Let us assume that the polynomial has the root: $\frac{a}{b}$, with a and b both in \mathbb{Z} and relatively prime. Then: $a^3 = 2b^3$, and it follows that a is even. If 2 divides a , then 2^3 divides a^3 . Since $a^3 = 2b^3$, 2^3 will divide $2b^3$, hence 2^2 will divide b . b is therefore even, which contradicts the hypothesis that a and b were relatively prime.

²⁶Otte [2003], p. 183.

²⁷We might say, using a kuhnian terminology, that the picture I have offered holds, in its generality, for today normal science’, for instance, the content of mathematics as it is apprehended in standard textbooks.

This viewpoint is clearly stated in the classical booklet by F. Klein *Famous Problems of Elementary geometry*:

The singular thing is that elementary geometry furnishes no answer to the question. We must fall back upon algebra and the higher analysis. The question then arises: How shall we use the language of these sciences to express the employment of straight edge and compasses? This new method of attack is rendered necessary because elementary geometry possesses no general method, no algorithm, as do the last two sciences.²⁸

According to Klein's views, that have become nowadays current,²⁹ it results that statements about the possibilities of different solving methods were not amenable to investigation unless one could appeal to algebra and analysis, conceived as meta-theories of geometry, in order to translate geometric problems and construction procedures.

In the light of these considerations, the distinction between absolute and conditional impossibility results can be now reformulated as a distinction between two types of impossibility proofs. On one hand, proofs that a construction cannot be obtained within a certain context C if a specific choice of the construction tools is required. Such impossibility proofs are obtained by appealing to another context C' for speaking of C , and can be called 'extra-theoretical'. On the other hand, we also recognize proofs showing that if it were the case that an object obtained in a given context C , something impossible would follow: these proofs do not require another context C' to speak of the context C , and can be called 'intra-theoretical'. Indirect arguments as the one deployed in *El. I*, 27 are, generally, intratheoretical impossibility proofs of this kind.

1.4 Impossibility statements as meta-statements

Scholars agree, when considering examples of extra-theoretical impossibility results, that ancient geometers hardly possessed any argument that could qualify as (or equivalent to) an extra-theoretical impossibility proof in the modern sense.³⁰ Indeed, it is difficult

²⁸Klein [1895], p. 2.

²⁹For instance: Courant and Robbins [1996], p. 120, Smorynski [2007], p. 89.

³⁰The opinions of the scholars is in general concordant on the issue. See for instance Becker's consideration: "It is not known whether they [the ancients] could prove that, for instance, the problem of duplicating the cube is not solvable by ruler and compass alone. We do not even know with certainty whether a method in order to carry out such an impossibility proof obtains, which remains within the territory of Greek mathematics" (Becker [1957], p. 75).

to envisage an analogous impossibility proof framed within the geometric manner of the ancients. It may be conjectured, for instance, that a method able to prove the impossibility of solving a problem (e.g. the duplication of the cube) by prescribed methods (e.g. straight lines and circles only), within the framework of classical analysis and geometry, should be able to survey all possible (plane) constructions and conclude that no one of them can solve the problem. I have not been able to find, however, which methods or arguments, in classical Greek geometry, could attain such a level of generality.³¹

However, evaluating ancient attempts to solve problems like the duplication of the cube, the trisection of the angle and the squaring of the circle, a scholar like Heath states unhesitatingly that: "Greek geometers came very early to the conclusion that the three problems in question were not *plane*, but required for their solution either higher curves than circles, or constructions more mechanical in character than the mere use of the ruler and compass in the sense of Euclid's postulates 1-3".³²

Heath does not delve further into this claim, but surveys in detail the ancient constructive solutions to the classic problems. Of course, solving a problem by higher curves than circles is not sufficient to claim that the problem is not plane: we can thus wonder on which ground Greek geometers could have based their conviction that the classic problems of construction were unsolvable by plane methods.

Occasional deliberations about the impossibility of solving a problem by given means can be found, especially among authors of late antiquity (I will try to explain later on a plausible reason why earlier Greek geometers remained silent). A shining example is the *Mathematical Collection*, a miscellaneous work written by Pappus of Alexandria in early fourth century AD. This is not only an outstanding text in ancient mathematics, but also one of the most influential sources in late XVIth and XVIIth century.³³

³¹Interesting considerations with respect to the scope and limits of ancient methods for problem-solving can be found in Hintikka and Remes [1974], p. 57, and Saito and Sidoli [2010], p. 587. The fact that ancient geometers had not produced, to my knowledge, such a proof, does not imply that this impossibility proof is itself impossible, in the framework of a theory which formalizes relevant aspects of ancient geometric theories. An interesting to raise, with regard to this problem, concerns the conditions that a formal system should comply with in order to derive extra-theoretical impossibility proofs within the theory itself.

³²Heath [1981], p. 219.

³³The *Collection* is a treatise of which most of books II through VIII are extant. These books preserve a wealth of material on the ancient geometric tradition, much of which would otherwise be unknown to us. But as the leading teacher of mathematics and astronomy at Alexandria, Pappus was most influential in his own time for his commentaries on Ptolemy and Euclid (for general information on Pappus' life, his work and mathematical agenda, see Pappus 1986, p. 2-62; Cuomo [2007], and Mansfeld [1998], in partic-

At the beginning of book III of the *Collection*, Pappus criticizes the sketch of an alleged plane solution (that is, a solution appealing to circles and straight lines only, employed according to Euclid's first three postulates) of the problem of finding two mean proportionals in continuous proportion, proposed, so Pappus states, by an "inexperienced geometer".³⁴

The mean proportionals problem is the problem of constructing, given two line segments a and b , two segments x and y such that the following proportion holds: $a : x = x : y = y : b$. It is easy to see that: $ay = x^2$, $bx = y^2$, $xy = ab$, and therefore: $x^3 = a^2b$. Since this is an irreducible equation of third degree, we know that the problem cannot be solved by plane means.³⁵ I observe that if we posit: $b = 2a$, the solution of this problem will solve also the duplication of a cube with side equal to a : the reduction of the duplication problem to the insertion of two mean proportionals was well known to Greek mathematicians.³⁶

The content of Pappus' criticism is not easy to define, because it mingles various arguments, and Pappus' exposition relies on several intricate digressions. At any rate, his objections can be grouped around three main points:³⁷ whereas two of these objections concern certain fallacies allegedly committed by the inexperienced proponent, that I shall not explore here, the third objection will interest more closely my narration. In fact, while scrutinizing, at the outset of Book III of the *Collection*, the flawed solution to this very problem advanced by the "inexperienced geometer", Pappus remarks that the former has taken: "the thing sought for as admitted", and has been deluded by the impossibility of constructing the givens, since the problem of inserting two mean proportionals "is indeed solid by nature".³⁸

ular chapter 2). Concerning the fortune of the text, in XVIIth century, I signal Pappus' latin translation prepared by F. Commandinus, appeared posthumously in 1588 (in bibliography: Commandinus [1588]). The *Mathematical Collection*, however, was also known before, thanks to Greek manuscripts circulating among mathematicians and humanists (see Bos [2001], p. 37, Treewek [1957]).

³⁴Pappus refers to someone who "puts the thing forward in an inexperienced way" ($\pi\omega\tau\ \acute{\alpha}\rho\epsilon\acute{\iota}\rho\omega\tau\ \pi\rho\omicron\beta\acute{\alpha}\lambda\lambda\omega\nu$). Cf. Pappus [1876-1878], vol. I, p. 31, line 16.

³⁵An important catalogue of solutions of the mean proportionals problem (obtained either by mechanical methods or curves higher than plane ones) can be found in Eutocius' Commentary On Archimedes' *The Sphere and the Cylinder* (Archimedes [1881], vol. 3).

³⁶According to Proclus' account, it should be attributed to the mathematicians Hippocrates of Chios: "Reduction is a transition from a problem or a theorem to another one which, if known or constructed, will make the original proposition evident. For example to solve the problem of the duplication of the cube geometers shifted their inquiry to another on which this depends, namely, the finding of two mean proportionals". Proclus [1992], p. 167.

³⁷Cuomo [2007], p. 132.

³⁸Pappus [1876-1878], vol. I, p. 40, 42. See Hintikka and Remes [1974], p. 79.

The core of this criticism lies, so it seems, in the fact that the unskilled geometer has improperly applied straight line-and-circle constructions to a solid problem, namely a problem that can be adequately solved only by higher curves, like conic sections, or by equivalent mechanical methods. I remark that Pappus assumed the unsolvability of the problem of inserting two proportionals by plane method as a matter of principle, and expressed no desire to prove or argue for it.³⁹ In book IV of the *Collection* (Pappus [1876-1878] vol. I, p. 271), we learn that Pappus suggested that the trisection of an angle was unsolvable by planar means. Also in this case, he did not offer any justification for unsolvability of the trisection problem by straight-lines-and-circles constructions.

Pappus did not justify the impossibility of solving the classical problems of cube duplication (and insertion of two mean proportionals) or the trisection of the angle by ruler and compass. We might thus suppose that he grounded his conviction on a tradition of commentary and research on these problems. It should be recalled, in fact, that the cube duplication and the trisection of the angle were topical problems in Greek classical geometry, and could claim a long tradition of research and numerous attempts to their solution.⁴⁰ It is thus possible that mathematicians became convinced that these two problems were ‘plane by nature’.⁴¹ Pappus might refer to such a tradition when he ruled out attempts to solve solid problems by planar means, and thus conclude, on this ground, that embarking in the attempt to construct two mean proportions or trisect an angle by ruler and compass was an investigation into the impossible, which revealed, at most, ignorance about the previous tradition of research on these problems. Conclusively, at least in the context of Pappus’ discussion, and probably among mathematicians of late antiquity too,⁴² conditional impossibility claims had the status of principles regulating the activity of problem-solving, rather than that of mathematical theorems.

Are these deliberations on the nature of certain problems to be found in earlier texts belonging to the Greek corpus? I am not aware of any such case in earlier mathematical literature properly (for instance, Euclid, Archimedes or Apollonius). One reason for thos silence on impossibility claims in mathematical texts is probably due to the fact that methodological considerations about mathematics (which included considerations

³⁹The point is made in Lützen [2010], p. 5-6, to which I am particularly indebted.

⁴⁰For the cube duplication, see in particular Saito [1985], p. 119. For the trisection of the angle, see, in particular: Heath [1981], p. 235.

⁴¹See also Knorr [1986], p. 361.

⁴²A similar judgement about the problem of inserting two means is expressed also in Hero’s mechanics, quoted in Knorr [1989], p. 11.

about legitimate and illegitimate methods) were treated, during the hellenistic period, in philosophical rather than mathematical texts. Such a rigid division of tasks lost its strenght later on, so that for someone like Pappus it would have been admissible to enrich mathematical discussions with methodological and philosophical considerations.⁴³

Consistently with this image of the ancient mathematics, I recall that the earliest surviving claims about the unsolvability of the circle-squaring problem, the third classic problem of antiquity, are to be found not among the considerations of a mathematician, but of philosophers like Aristotle, that I will discuss in the next section.

1.4.1 The unsettled nature of the circle-squaring problem

The circle-squaring problem stood presumably as the most elusive case among the three classic problems of antiquity, since its solution was not successfully settled by the ancients.

I recall that the term ‘quadrature of the circle’ did not concern for ancient, and for a good part of early modern geometers too, the problem of measuring an area, provided a unity of measurement is established in the backdrop. The concepts of length, area and volume, as we understand them today, namely as numerical measures of certain magnitudes (a line, a surface or a body) were extraneous to Greek geometry. Thus we never encounter, in the writings of ancient Greek geometers, a general concept of area (volume or length), nor claim like: "the area of the triangle is the half product of its basis by its height", nor a question like: "what is the area of the circle (by which we mean what is the number which expresses its surface)?" would have been formulated as such.⁴⁴

The meanings of ‘length’ of a segment or ‘area’ of a surface were tacitly understood as known from intuition (see Boyer [1959], p. 32). In the tradition of Greek geometry, the problem of squaring a given figure consisted in the construction of a polygons equal to that figure, or a polygon whose ratio with the figure to be squared could be expressed numerically. In the latter case, moreover, it would be easy to convert the proportion so obtained in an exact construction procedure.⁴⁵

⁴³On the methodological considerations in Pappus’ *Collection*, see Cuomo [2007], p. 170ff.

⁴⁴*Cf.* Boyer [1959], p. 32.

⁴⁵It should not be forgotten, on the other side, that reference to area could occur, in classical mathematics, in the context of the operation of the ‘application of area’: ‘To apply an area to a (straight) line’ meant ‘to construct a parallelogram along that line’. The parallelogram might have the line segment as one of its sides, known as ‘the parabolic application’ of area (*Elements* I. 44), or it may exceed the seg-

The common way of proceeding would require to bound the figure to be squared – generally delimited by a straight line and a curved line, if it was not a closed figure already, like a circle or an ellipse – by a parallelogram, and then determine their ratio. Thus, while we say that ‘the area of a triangle T measures one half of the product of its base by its height’, a classical geometer would have reached an analogous conclusion by writing down a proportion between the triangle T , a rectangle R constructed on the same basis, and a couple of numbers, like: $T : R = 1 : 2$.

In general, squaring a polygon is a problem within the purview of Euclid’s *Elements*: it can be solved, in an elementary way, by constructing a rectangle equal to a given polygon (*El.* I, 45), and then by squaring the rectangle thus obtained (*El.* II, 14).⁴⁶ Greek geometers obtained important results concerning problems of a higher order of difficulty, like the quadratures of some curvilinear surfaces (and volumes): one of the most outstanding was obtained by Archimedes and established that the area of a parabolic segment P (namely the figure bounded by a parabolic arc and having as basis a chord of the parabola) is $\frac{4}{3}$ of the triangle T_0 having same basis and same height as the parabolic segment: $P : T_0 = 4 : 3$.⁴⁷

However, no similar results were found for the case of the squaring of the circle: the reason appears for us obvious, since the ratio between a circle and a suitably chosen rectangle (for instance the square built on the diameter of the circle) cannot be expressed as a ratio of numbers conceivable within the bounds of classical mathematics. Nevertheless, Greek geometers tried to solve the circle-squaring problem, and eventually came up if not with definitive, yet with outstanding results. According to the classical survey given by Tropfke, they pursued three main directions of research. The first one consisted in trying to construct a square equal to a given circle by ruler and compass only. The second method required higher order, mechanical curves, whereas the third method did not consist in finding a construction properly, but an approximate computation of the area of the circle (we should more correctly refer, in this case, to the measurement of the circle).⁴⁸

ment – “the hyperbolical application” (*Elements*, VI. 29), or fall short of it – ‘the elliptical application’ (*El.*, VI. 28).

⁴⁶Cf. Proclus [1992], p. 334-335.

⁴⁷Cf. Archimedes [1881], vol. 2, p. 293ff; for an english translation: Heath [1897], p. 233.

⁴⁸Tropfke [1902], p. 110.

Tropfke also adds, few lines later, that: "only the modern times have brought about the knowledge that the first way is wholly impossible",⁴⁹ so that a solution of the circle-squaring problem could be found either by infinite methods or by special curves. But it should be remarked that claims to the impossibility of effectuating the quadrature of the circle by elementary methods occurred already in antiquity, and exerted a considerable influence on early modern geometers.

Possibly the fundamental and most influential among the ancient contributions to the understanding of the circle-squaring problem came from Archimedes. In particular, Archimedes proved, in the first proposition of the *Dimensio Circuli*, an important theorem stating that the area of any circle is equal to a right-angled triangle, in which one of the sides about the right angle is equal to the radius, and the other to the circumference of the circle. This theorem entails a noteworthy consequence: it is sufficient to construct a straight line equal to the circumference of a given circle in order to construct a triangle equal to the circle, and solve, in this way, the quadrature of the circle.⁵⁰

The Archimedean reduction of the quadrature problem to the rectification of the circumference is based on the rounding off of the circumference by the construction of the sequence $\{p_n\}$ of inscribed regular polygons, and the sequence $\{P_n\}$ of similar circumscribed regular polygons, each polygon of the sequence being obtained by successively halving the sides of the previous one. In order to understand how the rounding off process intervenes in such reduction, one can venture the following reconstruction of the archimedean reasoning underlying the proof of proposition 1 of *Dimensio Circuli*.⁵¹

To establish the result stated in Archimedes' text, one would need to assume the following premisses (implicit in the extant version of the *Dimensio circuli*):

1. The perimeters of every inscribed polygon is smaller than, and the perimeter of every circumscribed polygon is greater than the circumference of the circle.
2. The in-radii of the polygons inscribed and circumscribed to a given circle are respectively less than and equal to the radius of the circle.
3. The area of a regular polygon is equal to the rectangle formed by one-half its perimeter and its in-radius.

⁴⁹See Lindemann [1882].

⁵⁰See Archimedes [1881], vol. I, p. 257ff.; Dijksterhuis and Knorr [1987], p. 222.

⁵¹Archimedes [1881], vol. I, p. 260-262.

On the strength of 1, 2 and 3 one can note that the rectangle formed by one-half the circumference of a circle C and its radius is greater than the area of every regular polygon inscribed in C , and smaller than the area of every regular polygon circumscribed to it. From this, it can be proved, by the method of exhaustion, that the difference between the area of the circle and the rectangle formed by one-half the circumference and the radius can be made less than any preassigned quantity (this last proof is contained in the text of *Dimensio Circuli*).⁵²

It should be pointed out that Archimedes did not solve the circle-squaring problem, but proved its equivalence with the problem of rectifying its circumference.⁵³ This result might have suggested a way to attack the quadrature problem by passing through the rectification of its circumference, but this route was not an easier one: ancient geometers probably encountered deep technical and conceptual difficulties as they sought actually to construct a segment equal to the circumference of a given circle. I will confine myself to discussing two issues concerning the problem of rectifying the circle, which emerged in ancient geometry and exerted a long-standing influence over XVIIth century debates around the possibility or impossibility of solving the quadrature of the circle.⁵⁴

The first issue concerns the constructability of a straight line equal to the circumference of a circle. Ancient and medieval commentators felt bound to supplement the proof of theorem 1 of the *Dimensio Circuli* with a postulate stating that one can produce a straight line equal to a circle.⁵⁵

The reason which urged ancient geometers to explicate this assumption may be traced back to an Aristotelian standpoint, which was highly influential especially on early modern geometers, as mainline historiography of mathematics has often stressed.⁵⁶ In the seventh book of *Physics* (VII, 4, 248 a-b), for instance, Aristotle advanced an argu-

⁵²See Knorr [1986], p. 153-154.

⁵³Incidentally, I observe that this theorem represented a paradigmatic example of the reducibility of quadrature problems to rectification ones, which became a general *desideratum* among geometers in the second half of XVIIth century. We read, for instance, in a letter written by Leibniz to Huygens in the 1690s: "je souhaite de pouvoir tousjours reduire les dimensions des aires ou espaces, aux dimensions des lignes, comme plus simples. Et c'est pour cela qu'Archimede a reduit l'aire du cercle a la circomference" (AIII5, 17, p. 96). On the issue of reducibility of quadratures to rectifications, see Blasjo [2012].

⁵⁴My discussion is particularly indebted to Molland [1991].

⁵⁵The postulate is explicit in Eutocius' Commentary (Cf. Archimedes [1881], vol. 3, p. 267), and in two medieval commentaries, the Cambridge and the Corpus Christi manuscripts of the *Dimensio Circuli* (Clagett [1964], p. 68, 170, 382ff., 414ff.).

⁵⁶See Baron [1969], p. 223-228; Bos [2001], p. 342 Hofmann [2008], p. 101-103.

ment for the ‘non-comparability’ between circular and straight motion. This argument, although tantalizing in its vagueness, can be captured by the following scheme:

- Let us suppose that every movement is comparable (*symbleta*) in speed with every other.
- Hence, straight and circular motions are comparable (*symbleta*).
- Movements of equal speed are those that cover equal distances in equal times (which is admitted).
- There will be curvilinear movements which cover equal distances in equal times with rectilinear movements.
- Therefore, there are curves equal to straight lines.
- Thus, segments and arcs will be comparable, which is absurd.⁵⁷

Aristotle did not directly argue for impossibility of comparing arcs and straight lines, but took this claim for granted in the course of an argument concerning the impossibility of comparing straight and circular motions. On the ground of this example, we might suppose that a belief in the ‘non comparability’ of circles and straight lines was circulating among mathematicians, in Aristotle’s time, namely by the fourth century B.C.

By claiming that arcs and straight lines cannot be compared, Aristotle possibly meant that circles and lines could not be made to coincide with each other, through some licensed geometric construction.⁵⁸ If the possibility of comparing circular and straight segments

⁵⁷The translation of the original passage can be found in Heath [1998]: "The question may be raised whether every motion is comparable with every other or not. If all motions are comparable and things have the same speed when they move an equal amount in an equal time, then we may have a circular arc equal to a straight line, while of course it may be greater or less". Few lines later we can read: "...but once more, if the motions are comparable, we are met by the difficulty aforesaid, namely that we shall have a straight line equal to a circle. But these are not comparable; therefore neither are the motions comparable". Heath [1998], p. 140-141.

⁵⁸A different interpretation is given by Ross: "One would have expected him [Aristotle] to accept as obvious that a curve may be longer or shorter than a straight line, even if he did not admit that it could be equal to one; for this is suggested by very obvious facts of experience. It seems probable that the fact on which he is relying is that a straight line and a curve are οὐ συνβλητά, i.e. that there is no unitary line of which both are multiples, and that from this he wrongly infers that a straight line cannot be either equal to or lesser than a curve" (Aristotle [1936], p. 677-78). Ross’ interpretation tends to read the non compatibility between straight and curved lines in terms of incommensurability, in analogy with the famous incommensurability between the side and diagonal of a square. I am not competent enough, on the exegesis of Aristotle, to question Ross’ interpretation, but I can stress that later interpreters took Aristotle’s passage as a vindication of the belief that circular and straight lines are not comparable. I shall offer examples below.

were denied, one would also lack the conditions under which it could be operationally decided whether, given a circular arc B , a segment A could be constructed such that $A < B$, or $B < A$, or $A = B$. Hence the rectification of the circle, namely the construction of a segment A equal to a given circular arc B , would be in principle impossible. On the contrary, we know from other sources⁵⁹ that Aristotle might allow the solvability in principle of the circle-squaring problem.⁶⁰ Aristotle might not be expressing incoherent views here, as we cannot exclude that he ignored the equivalence between the quadrature of the circle and the rectification of its circumference, proved only later, by Archimedes.⁶¹

However, the aristotelian passage was emphasized in a medieval commentary on the seventh book of the *Physics*, written by Averroes during the twelfth century, and translated into latin during the renaissance. If, on one hand, Averroes stressed, in the footsteps of Aristotle, that there cannot be a straight line equal to a circular arc, on the other he admitted the possibility of comparing, via superposition, straight segments with other segments, and arcs with other arcs on the same circle, since in either of the two cases, they belonged to the same kind.⁶² In Averroes' commentary, in particular, the incomparability between straight and circular lines is explained on the ground that these entities belong to different kinds: this view might have been shared by Aristotle himself, as it probably grew up as a fundamental divide within ancient classifications of curves.⁶³

The Aristotelian standpoint on the impossibility of comparing straight lines and circular arcs, mediated by Averroes' interpretation, exerted a long-range influence onto early

⁵⁹Cf. chapter 7 of Aristotle's *Categories* (Cf. Knorr [1986], p. 361).

⁶⁰Occasionally, we find among Aristotle's writings critical discussions of contemporary or earlier attempts to solve the circle-squaring problem. A survey of Aristotle's opinions on the different quadratures of the circle can be found in Mueller [1982].

⁶¹This hypothesis is advanced, for instance, in Mendell [2008].

⁶²I report Averroes' explanation in the latin translation of 1550-1552, by Bagolinus: "non est proportionalitas secundum veritatem inter lineam rectam et circularem . . . et intendebat per hoc, quod impossibile est de quantitibus esse aequales nisi rectas tantum aut circulares tantum, scilicet quae sunt ejusdem speciei, cum istae sibi superponantur; et ideo dicimus, quod quantitates curvae non aequabuntur nisi sint ejusdem circuli" (in Hofmann [1941/42], p. 6: "there is no proportion between the straight line and the circular, according to the truth . . . and he [Aristotle] meant by this, that it is impossible for these quantities to be equal, unless they are both straight or both circular lines, which are indeed of the same species, since in this case they can superimpose; and in the same way we say that curved quantities cannot be made equal unless they belong to the same circle").

⁶³Aristotle also embraces a fundamental classification of curves into straight and circular in *De Caelo*, I 2, 268 b, 17-20: "But all movement that is in place, all locomotion, as we term it, is either straight or circular or a combination of these two, which are the only simple movements. And the reason of this is that these two, the straight and the circular line, are the only simple magnitudes" (eng. tr. in Aristotle [1922]). Cf. also note 32 in this dissertation.

modern geometry.⁶⁴ It eventually acquired the role of a ‘mathematical dogma’, a precept against the exact solvability of rectification problems, and therefore against the solvability of the quadrature of the circle too, which loomed large in the mathematical community until the half of XVIIth century, as I shall discuss in chapter 6.⁶⁵

Despite the evidence for any definitive conclusion concerning the view about the non-comparability between straight and curvilinear lines is tenuous, a conjecture can be gleaned from the previous discussion. I suggest that the ‘dogma’ of the non-comparability between straight and curved lines, possibly originated in the geometry of Aristotle’s time, and later revived through the circulation of the aristotelian corpus and through its commentaries (Averroes is but one among them), might have exerted a durable, although not uncontested influence on later mathematics, as an example of impossibility ‘in the beginning’. As far as the impossibility of solving the circle-squaring problem was not derived from a mathematical proof, but it was grounded on a belief on the non-comparability between straight and curves, perhaps justified on broad metaphysical reasons (curvilinear and straight lines belong to different kinds), it might have acquired the status of a principle in order to regulate the very activity of problem-solving, rather than a theorem within the corpus of mathematics.

However, this view was contested since antiquity: objections can be found, in particular, in the archimedean tradition. As a start, let us point out that the impossibility of com-

⁶⁴Compare, on this concern, the informed study by J. E. Hofmann in Hofmann [1941/42], and Hofmann [2008], p. 101ff.

⁶⁵Aristotle’s dogma resonates in Descartes’ *Géométrie* as we can read in Descartes [1897-1913], vol. 6, p. 412: "La proportion, qui est entre les droites et les courbes, n’est pas connue, et mesme ie croy ne le pouvant pas estre par les hommes, on ne pourroit rien conclure de là qui fust exact et assuré". See also Baron [1969], p. 223-228; Bos [2001], p. 342. Both the expressions "mathematical dogma" and "axiom" are employed by Hofmann in the already quoted study Hofmann [1941/42], and in Hofmann [2008], p. 101. The latter, in particular, notes: "Er muss aber in kirchlichen Kreisen eine grosse Rolle gespielt, und sich schliesslich, von einem Aristoteles-Kommentars in den andern übernommen, zu einem Art von mathematischem Dogma entwickeln haben. Leider, lässt sich dieser Vorgang im Augenblick nicht näher verfolgen, da von den zahlreichen Traktaten der Spätscholastiker über der Kreisquadratur, nur der kleinste Teil im druck zugänglich und wahrscheinlich viele Interessante für immer verloren ist." (Hofmann [1941/42], p. 16: "It must have played a tangible role in ecclesiastic circles, and finally, it must have turned, transmitted from one commentary of Aristotle to the other, into a kind of mathematical dogma. Unfortunately, this process is no more extant close to our eyes, since of the numerous treatises of late Scholastics on the quadrature of the circle, only the smallest part was printed, and plausibly many interesting ones are forever lost"). Claims to the impossibility of comparing circular arcs and straight lines, or curvilinear arcs and straight lines are advanced, for instance, by numerous scholars from the early XVIIth century, among them, for instance, Viète and Kepler, as the investigation led by Breger shows (Breger [1991], p. 36ff.). I could not ascertain (nor Breger’s analysis carries information on this concern) which was the origin of this tradition, or whether this belief spread from a relevant episode or a main publication.

paring segments and circular arcs is denied by one of the fundamental assumptions in Archimedes' proof of the first theorem of the *Dimensio circuli*, evoked above: the perimeters of every inscribed polygon is smaller than, and the perimeter of every circumscribed polygon is greater than the circumference of the circle. This assumption can be seen as obvious in virtue of two postulates, formulated by Archimedes at the outset of the first book of the *Sphere and the Cylinder*: the shortest distance between two points is the segment joining them, and of two curves with the same extremities and convex in the same direction, the one which contains the other has greater length (the same postulate can be generalized to curved surfaces).⁶⁶

Robust objections against the aristotelian thesis on the non-comparability between straight and circular lines were raised by commentators of Archimede's work. Eutocius, an early VIth century author of influential commentaries on Archimedes and Apollonius, wrote, commenting the first proposition of the *Dimensio circuli*:

For it is somehow clear to everyone that the circumference of the circle is some magnitude, I believe, and this is among those extended in one [sc. dimension] while the straight line is of the same kind. Even if it seemed not yet possible to produce a straight line equal to the circumference of the circle, nevertheless, the fact that there exists some straight line by nature equal to it is deemed by no one to be a matter of investigation.⁶⁷

Eutocius strongly affirms that the existence of a straight line equal 'by nature' to a circumference is a matter beyond doubts, even if its actual construction had not been found out yet. By separating a concern for existence from a concern for constructability, Eutocius possibly intended to rule out the non-comparability in principle between straight and curve magnitudes, and thus establish the problem of rectifying the circumference as a legitimate question, a question still worth investigating.

The medieval *Corpus Christi* version of the *Dimensio Circuli* (Clagett [1964], p. 170ff.) incorporated the claim to the existence of a straight line equal to a circle, and more generally, the concern for the comparability of straight and circular segments, by interpolating the original archimedeia text with three postulates, "known *per se* and recognized by anyone" (*ibid.*):

⁶⁶Archimedes [1881], vol. 1, p. 8-9. These postulates were probably implicit in his *Dimensio circuli*, as suggested in Knorr [1986], p. 155.

⁶⁷Archimedes [1881], vol. 3, p. 266. Eng. tr. in: Knorr [1986], p. 362.

Primum est, quor arcus sit maior corda.⁶⁸

Secundum petitorum est, quod linea curva sit aequalis rectae.⁶⁹

Tercium petitorum tale est: quaelibet linea curva duobus terminis arcus circumferentialis conterminata ex parte convexitatis arcus arcum ambiens maior est illo arcu.⁷⁰

Even when the comparability between straight and curves was conceded, ancient sources recorded some disagreement on what should count as a legitimate solution to the rectification problem: this is the second conceptual issue related to this problem I shall sketch here, and that I shall develop in this study. A simple, almost naive way to go about with the rectification of the circumference would be to wrap a string around a circle and subsequently straighten it, or let a circle roll along a line: both procedures are evoked by the anonymous medieval commentator of Archimedes' *Corpus christi* version, although not as solution to the rectification of the circumference.⁷¹ It can be doubted, in fact, whether such an 'empirical' solution were ever taken as offering any insight into the structure of the problem, and thus whether they ever qualified as geometrical.⁷²

On a higher level of sophistication, ancient geometers defined special curves, like the quadratrix or the spiral, both generated by the composition of two simultaneous motions,

⁶⁸Eng. translation in Clagett [1964], p. 171: "The first of the three postulates is that an arc is greater than [its] chord".

⁶⁹Clagett [1964], p. 171: "The second of the postulates is that a curved line be equal to a straight line."

⁷⁰Clagett [1964], p. 173: "the third of the postulates is as follows: any curved line sharing the two termini or a circumferential arc and including it in the direction of the convexity of the arc, is greater than the arc."

⁷¹In Clagett [1964], p. 171: "For if a hair or silk thread is bent around circumference-wise in a plane surface and then afterwards is extended in a straight line in the same plane, who will doubt - unless he is hare-brained (*cerebrosus*) - that the hair or thread is the same, whether it is bent circumference-wise or extended in a straight line and is just as long as the one time as the other". This example, together with the well-known case of a wheel rolling on a tangent plane surface, is considered in order to justify the admissibility of the second postulate as a truth endowed with great evidence, not as a solution to the rectification problem.

⁷²Still in the second half of XVIIth century, Leibniz went back on the question, and referred to such attempts at rectifying the circumference by chords as "empirical quadratures": "Tamdiu quaesierint Geometrae, quid enim facilius quam rectam circumferentiae aequalem invenire, Circulo materiali filum circumligando, idque postea in rectum extendendo, ac mensurando ..." (AVII6, 19, p. 170: "But for a long time, geometers wondered what could be easier than finding a straight line equal to a circumference, by revolving a thread around a material circle, and afterwards straightening and measuring it."). However, Leibniz aptly recalled: "Verum sciendum est, tale quiddam a Geometris non quaeri" ("But it must be acknowledged that such a solution is not the one desired by the Geometers"). The role of chords in mathematical endeavors will be critically discussed by XVIIth century geometers: On Descartes' contributions to the question, see this study, 5.3.

uniform in time. As I shall discuss in the next chapter (see, in particular, section 2.3.2, 2.3.3) these curves did not obviously fit the bill of geometricity, since they were the target of ancient objections (especially concerning the quadratrix), known and revived by early modern geometers (see below, chapter 5).

These difficulties (as I will have the occasion to expound in the sequel, especially chapter 2, sec. 2.6) reveal that the ancients were divided on the nature of the circle-squaring problem. As a consequence, when XVIth and XVIIth century mathematicians read ancient writings, they could find to no extant arguments and techniques in order to solve the quadrature of the circle.⁷³

On one hand, the aristotelian belief on the non-comparability between straight and circular lines did circulate and exerted a non-negligible influence in the mathematical practice of early XVIIth century, in order to inhibit mathematicians from accepting the rectification of the circumference, and therefore the quadrature of the circle as a problem solvable in geometry. On the other, especially from the end of XVIth century, the diffusion of the latin version of Pappus' *Collection* (1588) instilled the hope that the circle-squaring problem could be overcome, if the geometrical nature of curves like the quadratrix or the spiral could be established on firm grounds.

The question became therefore incumbent on geometers, from the end of XVIth century onwards, to find criteria in order to decide which means should be considered as geometrically reliable as the circle and the straight lines, employed according to Euclid's postulates. These construction means constituted, at the time, the paradigm of exactness in geometry. In the backdrop of these considerations, I am now ready to broach the subject matter of my study.

1.5 Impossibility results in early modern geometry

The main problems and questions I shall address in my study are the following. How did early modern geometers prove (or argued for) the impossibilities of solving construction

⁷³Bos observed, on this concern, that in XVIth century mathematics several attempts to solve the circle-squaring problem by elementary means were discussed, and refuted. Although I cannot establish the motivations behind each of these attempts, I can advance the hypothesis that these attempts might be the consequence of the unclear status about the nature of the circle-squaring problem (*Cf.* Bos [2001], p. 25). One late XVIth century endeavor to provide a flawed solution by ruler and compass is analyzed in Hogendijk [2010].

problems by prescribed means? Can we identify similar structures and similar roles in different instances of these impossibility arguments?

Early modern geometry was deeply imbued with the legacy of ancient mathematics. As I shall argue in this dissertation, such a legacy did not only concern a body of challenging technical questions, with which early modern geometers could test the virtues of their own methods, but also metatheoretical views regarding, for example, classifications of geometric problems and curves.

In the previous sections, I have conjectured that impossibility results might have been conceived by the ancients as metastatements, i.e. norms which fixed the most adequate methods in problem-solving and sanctioned certain conducts as ungeometrical. As a key role in the transmission of such metatheoretical views was exerted by Pappus' *Mathematical Collection*, mediated by its numerous readings and interpretations, I shall start my investigation by inquiring whether early modern geometers inherited the views about impossibility results that I have attributed, on the basis of the texts, to the ancients, or whether they departed from ancient predicaments, or even corrected them in the light of new mathematical advances, represented, for instance, by the incorporation of algebra in geometric pursuits.

As a general methodological remark, I note that we cannot take for granted what a certain problem was, independently from its historical context. We can rather think of the context of a proof as its 'underlying narratives', constituted, for instance, by the earlier assessments and by the historical evolution of this very proof, by its circulation and the subsequent critiques, and more generally, by the philosophical and cultural influences in force at a given time, within a certain community: in brief, what constitutes a historical tradition. My study shall set out to describe the nature of impossibility results within a precise historical setting (from the beginning of XVIIth century and the second half of the 1670s) by selecting and investigating some relevant contexts in which these results were deployed.

In the first part of my dissertation (from chapter 2 to ch. 6), after a general overview of the main results contained in Book IV of Pappus' *Collection*, I shall examine Descartes' content and division of the subject matter of geometry, according to the programme presented in his epoch-making work *La Géométrie*. Broadly speaking, Descartes introduced, on the ground of an explicit criticism to the 'ancients', criteria for acceptable geometric

constructions, and offered a rational classification of the existing domain of problems on the basis of their constructability. My examination of *La Géométrie* will mainly concern the methodological points of this treatise: the foundations of the distinction between geometrical and mechanical curves, and the classification of curves and problems. A general thesis I shall illustrate is that conditional impossibility claims exerted a methodological, or metatheoretical role on two levels. Firstly, they contribute to frame the demarcation between acceptable and non acceptable curves. Secondly, conditional impossibility claims enter in the classification of problems on the ground of the curves which construct them, sketched in the third Book of *La Géométrie* and commented by Van Schooten in his latin editions from 1649 and 1659. The presence of impossibility claims in a treatise, like Descartes' *Géométrie*, dedicated to lay down the fundamentals of a method to solve all problems of geometry, is not surprising, in so far such a method should provide the guidelines in order to solve each problem according to the most adequate means.

An interesting sketch of a classification into possible and impossible problems can be found in Descartes' correspondence with Mersenne. In chapter 6, I will analyze this classification, and inquire about the nature of the circle-squaring problem with respect to the edifice of Descartes' geometry. The circle-squaring problem stood as an intriguing problem in the context of XVIth and XVIIth century research: it was not only a difficult mathematical question, but it had an important metatheoretical role, I surmise. Indeed decisions about its solvability in principle would contribute to frame the subject matter of geometry, by demarcating legitimate from illegitimate solving methods, as in the outstanding attempt led by Descartes in *La Géométrie*.

Furthermore, in the second half of XVIIth century, arguments asserting that the quadrature problem could not be solved by algebraic method would be invoked in order to demarcate finite from infinitesimal analysis (I shall investigate, in chapter 7 and 8, the case of J. Gregory and G. W. Leibniz, respectively).

In chapter 7 and 8, in particular, I shall investigate some fragments of two mathematical works in detail: James Gregory's work *Vera circuli et hyperbolae quadratura* (1667), and G. W. Leibniz's *De quadratura arithmetica circuli ellipseos et hyperbolae cujus corollarium est trigonometria sine tabulis* (1676). In this part of my work, I shall argue the general thesis that impossibility claims concerning the circle-squaring problem acquires a new status in the second half of XVIIth century. In order to defend this claim, I will detail a critical examination of James Gregory's work *Vera circuli et hyperbolae quadratura*. In

this text, in fact, Gregory sets out to search for a way to reduce the problem of squaring any sector of a central conic (the circle, the ellipse and the hyperbola), to an algebraic equation, and comes up with an argument in order to prove that the impossibility of this endeavor. Gregory's argument is faulty and was heavily criticized by his contemporaries, but it shows an uncommon insight, for his time, into impossibility results. Moreover, Gregory's thesis on the impossibility of finding an algebraic quadrature of the central conic sections are historically relevant because they exerted, through a subsequent controversy with Christiaan Huygens, a deep influence on Leibniz's mathematics.

Chapter 8 of my dissertation will be indeed dedicated to Leibniz's lengthy treatise *De quadratura arithmetica circuli ellipseos et hyperbolae*, composed and ultimated during Leibniz's stay in Paris. Although the treatise circulated, under different versions, among Leibniz friends and colleagues mathematicians from 1674, and historical evidence shows that Leibniz had a manuscript ready for publication in the year 1676, this document got lost, and the treatise never saw the publication in Leibniz's lifetime. My interest for the *De quadratura arithmetica* will be mainly directed towards the the concluding proposition LI, considered by Leibniz as the 'crowning' of his treatise: a theorem on the impossibility of squaring the circle, the ellipse and the hyperbola.

Leibniz allegedly proves, by an indirect argument, that there is no quadrature of the central conic sections (namely, the circle, the ellipse and the hyperbola) that is more geometrical than his own. Since the solution presented in the *De quadratura arithmetica* is obtained through an infinite series, the above claim amounts to saying that the solution to the quadrature of the circle, the ellipse and the hyperbola cannot be obtained by a finite algebraic equation. In this chapter I shall examine in detail the influence of the controversy between Gregory and Huygens over the genesis, the conception and certain results presented in Leibniz's *De Quadratura Arithmetica*. I shall then discuss the mathematical and methodological meaning of Leibniz's impossibility result, and I argue that Gregory's *Vera Circuli et hyperbolae quadratura* played a dependable role concerning the function of Leibniz's impossibility argument within the organization of the treatise on the arithmetical quadrature of the circle and the conic sections.

Finally, in a concluding chapter, I shall respond to the questions raised in the beginning of this section by assessing the function of impossibility results in the context of XVIIth century mathematics and, more particularly, with respect to the case studies that will be discussed in this dissertation. On this concern, I shall assess both with respect to today

extrathereotical impossibility theorems, and with respect to the metatheoretical claims of antiquity.

Chapter 2

Problem solving techniques in Ancient geometry

2.1 Introduction

In the context of XVIIth century, geometry was predominantly presented as a problem-oriented activity. Consistently with this, the basic facts of mathematics were not propositions whose truth or falsity was to be judged, but tasks - for instance, geometrical problems - to be performed by means of constructions.

Until well into XVIIth century, many problems and problem-solving methods were in various degrees inspired to ancient Greek sources. As I have already noted, besides basic core concepts and a collection of challenging problems,¹ ancient geometry also exerted a major influence on deliberations about the ordering of problems and the acceptability of solutions in force within a mathematical practice.²

In the context of early modern mathematics, such views were either tacitly assumed or overtly invoked in order both to fix admissible problem-solving procedures and to

¹Among the challenging problems from antiquity, we can quote two outstanding examples: the problem of Pappus (discussed in ch.3), and the so-called ‘problem of Apollonius’, a tangency problem consisting of constructing a sphere, or a circle, tangent to three given spheres or circles (see Boyer and Merzbach [1991], p. 129, for a general presentation, and Bos [2001], p. 111ff. for its early-modern assessments).

²As W. Knorr remarked, such deliberations concerned: "... How the ancients divided the geometric field according to the types of problems and the solving methods; what they viewed the special role of problems to be (...) what conditions they imposed on the techniques admissible for the solution of problems, and whether they judged that satisfactory solutions for the three special problems had actually been found", Knorr [1986], p. 6.

determine admissibility conditions for curves.³

I thus surmise that a survey on the principal methods and techniques in ancient problem-solving is important in order to understand the subsequent elaborations by early modern authors. In the following lines, I will confine myself to presenting three main techniques for solving geometric problems in the plane, following the classification proposed by Henk Bos (namely Bos [1984]), and addressing the interested reader to exhaustive studies on the topic.⁴ As Bos remarks:

The first category consists in constructing by means of a straight line which is shifted in a certain way along the given figure until a position is reached in which two line segments (both, or one of them, determined by the position of the straight line) are equal (...) the second category consists of constructions performed by instruments devised for the purpose of one special construction. The third category consists of constructions by means of the intersection of straight or curved lines, including higher order curves ...⁵

This presentation, albeit succinct, will serve as an introduction for the subsequent section, in which I shall discuss in more detail Pappus' *Mathematical Collection*, and especially its fourth book, which contains the most influential metatheoretical deliberations for early modern geometric practice.

The first category concerns the constructive technique known as *neusis*. The *neusis* can be depicted as operation in which a straight line AB pivots around a fixed point P , until the intercept AB between two given lines m and l , forming a fixed angle, is equal to a given segment δ (see fig. 2.1). At the end of the process, the segment δ can be thought of as being placed between the givens l and m , in such a way that it inclines towards P (this is the literal meaning of *neusis*).⁶

Neusis constructions were pervasive in Greek constructional practice: they were crucially employed, according to the surviving accounts, to solve the classical problems of inserting two mean proportionals and trisecting an arbitrary angle.⁷

³See Bos [2001], in particular chapter 1.

⁴For instance Bos [1984], p. 333; Panza [2011], especially p. 58-73.

⁵Bos [1984], p. 333-334.

⁶Bos [1984], p. 334. A particular example of a solution to a problem employing a *neusis* construction is discussed in Bos [2001], p. 28-29.

⁷Ancient instances are attested, by indirect evidence, already in Hippocrates [Knorr [1986], p. 34].

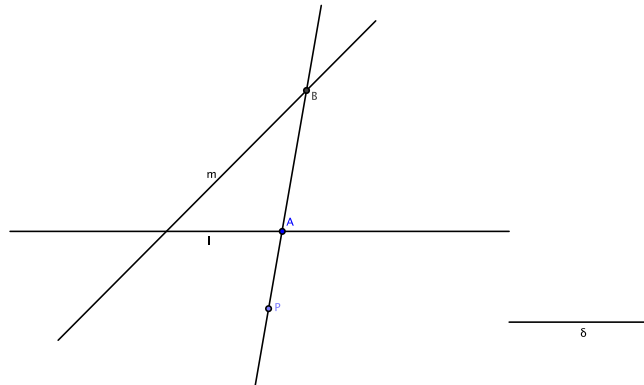

Figure 2.1.1: Neusis.

The use of the *neusis* in the construction of the problem of two mean proportions is described, for instance, in Eutocius' commentary to Archimedes' treatise on the *Sphere and the Cylinder* (Archimedes [1881], vol. III, p. 123-124), and it is attributed to the geometer Hero of Alexandria. A similar construction occurs in Pappus' *Collection* (Book IV, proposition 24).

Neusis is employed, in Pappus' *Collection*, also in relation with the trisection of a given angle (Book IV, proposition 32). In order to trisect the given acute angle $\widehat{CAB} = \varphi$, following Pappus' procedure, let a right angled triangle ABC with $\widehat{CAB} = \varphi$ be constructed (fig. 2.1). Complete the rectangle $ABCM$, call $AC = a$, and construct a line g passing through C and parallel to AB . In order to trisect the angle φ it is sufficient to insert, by *neusis*, a segment of given length $2a$ between lines CB and g . The angle \widehat{DAB} will be in fact the required angle.⁸

As we will examine, a full constructive solution also invoked the elaboration of a protocol in order to exhibit the required *neusis* via intersection of curves.⁹

⁸See, for the easy proof: Bos [2001], p. 54-55; Sefrin-Weis [2010], p. 148-150; Panza [2011], p. 60. The locus classicus of this construction can be found in Pappus' *Mathematical Collection*, Book IV, proposition 32 (Pappus [1876-1878], I, 275-276. Sefrin-Weis [2010], *loc. cit.*, for a modern english translation), a text well known by early modern writers, as I will comment later.

⁹This suggests that solutions obtained via *neusis* might not have been considered fully satisfactory, at least in late antiquity, therefore they required to be supplemented by a construction, either through intersection of curves or by means of a suitable instrument. Interestingly, though, the possibility of

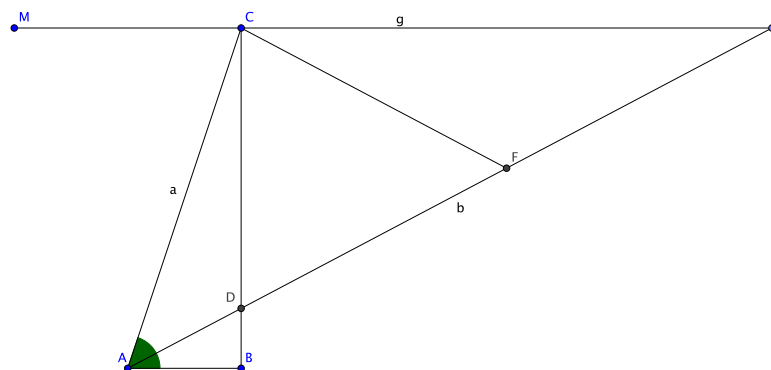

Figure 2.1.2: Neusis for the trisection of the angle.

The second category of construction methods concerns a special use of instruments in problem solving, consisting in making them indicate some points (which are then taken to be obtained) under the condition that some of their components coincide with some given geometrical objects, or meet some other conditions relative to given objects: when instruments are used in this way in order to solve mathematical problems, they are said to be used "in the pointing way".¹⁰

A well-known example in the early modern and in the ancient tradition is offered by an instrument attributed to the ancient mathematician Eratosthenes and called, in the Latin tradition, 'mesolabum'.¹¹

neusis of "any predefined distance" was revived, and given the special status of an additional postulate by François Viète, in his 1593 *Supplementum Geometriae* (see [Bos, 2001], p. 168-169). This possibility was never considered in antiquity and hardly received among Viète's contemporaries.

¹⁰Panza [2011], p. 62.

¹¹The Greek name for this instrument was literally 'taker of means' (Knorr [1986], p. 211). The term 'mesolabum' was originally contained in the latin translation of Eutocius' *Commentaries on Archimedes' "On the sphere and the cylinder"*. This text became available in print from the beginning of XVIth century (first in works of Valla and Werner), and subsequently in the edition of the works of Archimedes, published in 1544 and edited by Th. Geschauff (*Opera ... omnia ... nuncque primum et Graece et Latine in lucem edita ... Eutocii Acalonitae in eosdem Archimedis libros commentaria item graece et Latine ...*), and later in the edition of 1615, edited by D. Rivault (1571-1616): *Archimedis Opera quae extant. Novis demonstrationibus illustrata*.

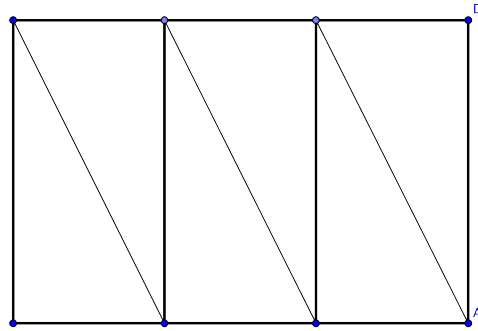
Figure 2.1.3: Eratosthenes' *Mesolabum*.

Eratosthenes' mesolabe is a mechanical device that can be described as formed by three rectangular plates of equal height, set out as in figure 3, which have the property of gliding one under the other.

By virtue of its design, this instrument was employed in order to solve the so-called problem of inserting two mean proportionals between two given segments,¹² namely the problem of constructing, given two line segments a and b , two segments x and y such that the following proportion holds: $a : x = x : y = y : b$. It can be easily shown, moreover, that the same instrument can solve the problem of inserting any number of segments $x_1 \dots x_n$ between given segments a and b , so as to satisfy the proportion: $a : x_1 = x_1 : x_2 = \dots : x_n = x_n : b$.

Let us consider the case of inserting two mean proportionals between a and b (with $a < b$). The plates which form the mesolabe can be so conceived that their height will

¹²An extant solution can be found in Eutocius' Commentary On Archimedes' *The Sphere and the Cylinder* ([Archimedes, 1881], vol. 3, p. 109), another one in Pappus' Book III of the *Collection* (Pappus [1876-1878], vol. I, p. 57). I recall that the solution using the mesolabum was just one among the numerous procedures for constructing, in antiquity and especially in the early modern period, the well-studied problem of the two mean proportionals (see Bos [2001], p. 27-34, Panza [2011], p. 64-70).

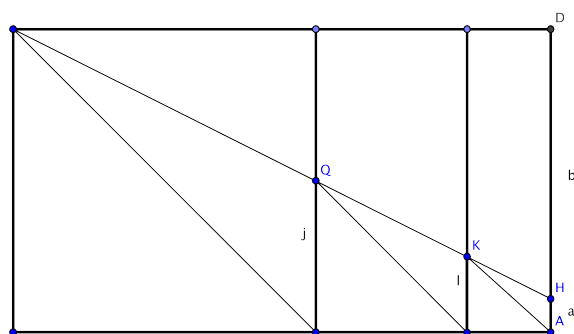

Figure 2.1.4: The insertion of two mean proportionals with the *Mesolabum*.

be equal to b (whereas the width can be arbitrarily chosen), and that on AD , edge of the first plate, a segment AH equal to a shall be marked off (in figure 2.1). Let us move the plates, or imagine them to be moved, and call Q and K the intersection points marked by the diagonals and the occluding edges between the third and second plate, and the second and first plate, respectively, when the plates are both gliding. In order to construct the required mean proportionals, the plates must be slid until points Q and K fall in a line with points D and H . If this configuration is reached (the final configuration, after the motion, is represented in figure 2.1), the segment l , projection of K on the base of the mesolabe, and segment j , projection of Q will be the desired mean proportionals between a and b . The proof can be easily supplemented by considering the similarity of the triangles in the final configuration.¹³

The solution of the problem of inserting two mean proportionals illustrates how Eratosthenes' mesolabe works in the so called 'pointing way': the instrument is not employed

¹³Knorr [1986], p. 211-212. The problem of inserting any number n of mean proportionals can be solved by applying the same protocol, once a suitable number of plates has been added: in particular, if n is the number of mean proportionals to be constructed, the number of plates to be added will be $n + 1$. The possibility of modifying this instrument in order to solve the problem for increasing values of n was certainly known to the ancients, as we can read in Eutocius: " a nobis autem methodus per instrumenta habilis inventa est, qua inter duas lineas datas non modo duas medias sumamus, sed quocumque quis voluerit" (Archimedes [1881], vol. III, p. 107)

for tracing a curve, but directly exhibits the required points (namely Q and K) in order to solve the problem.

As we will see, the mesolabe presents a certain kinship with the compass that Descartes described in his early reflections collected in the *Cogitationes Privatae* (a series of notes written between 1619-21), and subsequently with the instrument described in the second book of *La Géométrie* (see chapter 3 of this dissertation), which can be thought of as an evolution of both Descartes' early instrument and Eratosthenes' one.

Despite the similarity of their design, though, I point out that Descartes did not use his instrument in the pointing way, in his problem-solving techniques. On the contrary, Descartes employed it, as well as other geometrical instruments that he studied, in order to trace curves, which in turn could be used in order to construct problems.¹⁴ The standard method for problem-solving adopted by Descartes fell indeed into a third category described above in Bos [1984], that of solutions obtained by intersection of lines.

As an example of problem solved according to the third category, let us consider once more the procedure, illustrated in the *Collection*, in order to solve the trisection of an arbitrary angle. Pappus described, in proposition 32, how the construction of an angle equal to one third of a given angle could be obtained via a *neusis* (see figure 2.1). In the previous proposition 31, he had described how to construct that *neusis* by an intersection of two curves, a circle and an hyperbola.

Let us consider the second step, as it is dealt with by Pappus (figure 2.1). Given two perpendicular segments a and b intersecting at point A , a point O on the perpendicular to a at point B , and a given segment c , it is required to intercept, on the segment OF , a segment EF , between lines a and b , such that $EF = c$.

1. Complete the rectangle $ABOC$, and extend BO .
2. Describe, through point C , an hyperbola whose asymptotes are the lines BO (prolonged) and BA (prolonged, namely the line labelled as a). Let us recall that a hyperbola can be univocally described, since it is univocally determined if its asymptotes and a point through which it passes are given (*Cf.* Pappus, IV, 33).
3. Draw a circle with center C and radius equal to c . The circle so constructed will intersect the hyperbola in D .

¹⁴Bos [2001], p. 240-243, p. 339-340. Panza [2011], p. 74-78.

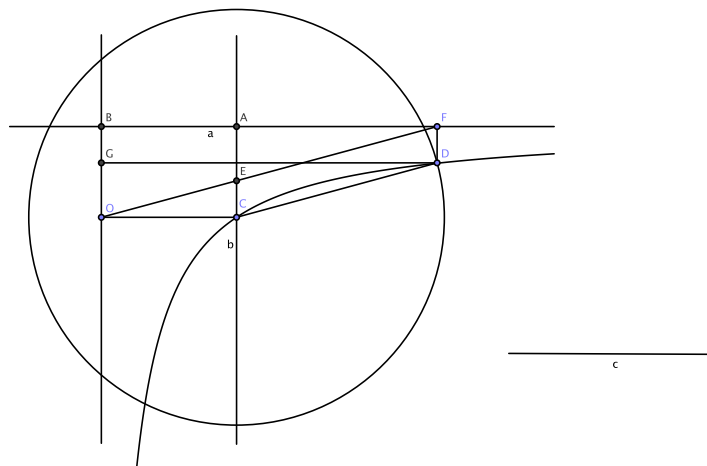

Figure 2.1.5: Pappus, *Collection*, IV, 31.

4. Through D , draw a parallel to AC , call F its intersection point with BA prolonged.
5. Draw segment OF and mark in E its intersection with AC .
6. The problem is thus solved, since $EF = c$.¹⁵

This construction provides a *neusis*, which can be employed to solve the trisection of the angle, as I have explicated above (see in particular, sec. 2.1, fig. 2.1).

The few examples here offered show with sufficient clarity that the three categories listed above did overlap: a problem solved via a *neusis* might be supplemented with a construction of the *neusis* by the intersection of two curves (as in the case of the trisection), or by an instrument used in the pointing way (for instance Erathostenes' mesolabe).

¹⁵An easy proof (Bos [2001], p. 54-55, where the original argument given by Pappus is resumed) consists in showing that $FECD$ is a parallelogram, and therefore that segment $EF = CD = c$. One can reason, as Pappus did, by tracing the parallel to a passing from D , which intersect BO in G . Since point D and C lie on an hyperbola whose asymptotes are the lines BO (prolonged) and BA (prolonged, namely the line labelled as a), the rectangles $FBGD$ and $ABOC$ are equal, because of the fundamental property (symptom) of this curve. From this equality we can derive the following proportion between the sides: $BF : BA = AC : FD$ (*). Considering the similarity between triangles BFO and COE , moreover, we obtain: $BF : BO = CO : CE$, i.e. $BF : CO = BO : CE$. Since $CO = BA$ and $BO = AC$, we have also: $BF : BA = AC : CE$ (**). In virtue of (*) and (**) we get: $AC : FD = AC : CE$, and therefore: $FD = CE$. Since the segments are supposed parallel, the figure $FECD$ is a parallelogram. Q.E.D.

It appears, however, from Books III and IV of the *Collection*, that the solution of problems via intersection of curves played a central methodological role in Pappus' view on the architecture of mathematics, and that such a role had a longstanding influence on the practice of early modern geometers too.

2.2 Pappus' division of problems into three kinds

As historians have shown, Pappus' *Mathematical Collection*, both in Greek and in Latin translation, largely circulated among mathematicians from the end of XVIth century, and had a recognizable role in systematizing aims and methods within the field of geometrical problem solving in early modern geometry.¹⁶

As I have noted in the introduction to this study, the historical importance of this text is not restricted to the fact that it offered a rich insight into the tradition of ancient mathematical problem solving. In fact it spread its influence over broadly methodological concerns. Among them, I will pay special attention, in this chapter, to his attempt to classify geometric problems, and in the next chapter, to one of the few surviving ancient accounts of the method of analysis.

The most extensive presentation of Pappus' classification of problems is contained in Book IV:

When the ancient geometers wished to trisect a given rectilinear angle, they got into difficulties for a reason such as the following. We say that there are three kinds (γένη) of problems in geometry, and that some <of the problems> are called 'plane' (ἐπίπεδα), others 'solid' (στερεά), and yet others 'linear' (γραμμικά). Now, those that can be solved by means of straight line and circle, one might fittingly call 'plane'. For the lines by means of which problems of this sort are found have their genesis in the plane as well. All those problems, however, that are solved when one employs for their invention either a single one or even several of the conic sections, have been called 'solid'. For it is necessary to use the surfaces of solid figures – I mean, however, (surfaces) of cones – in their construction. Finally, as a certain third kind of problems the so-called 'linear' kind is left over. For different lines, besides the ones

¹⁶Bos [2001], chapter 3 in particular. Let us recall that the influence of Pappus' *Collection* spread well into XVIIth century, as it is attested by the case of Newton (*cf.*, on this concern Guicciardini [2009], p. 294*ff.* for instance).

mentioned, are taken for their construction, which have a more varied and forced genesis, because they are generated out of less structured surfaces, and out of twisted motions.¹⁷

Pappus classified problems into ‘genera’ according to the means needed to solve them (a similar passage can be read in Book III). In this context, a ‘genus’ can be taken to qualify a collection of items (namely problems) linked by a relation (‘being solvable’) to certain objects (namely curves) and to one another. For instance, an item a belongs to the genus of plane (respectively solid, linear) problems if and only if it can be solved by straight and circles (respectively straight lines, circles + conic sections, or by any of the previous curves and higher curves).¹⁸

Curves are also sorted out in three genera, according to the mode of their generation.¹⁹ More precisely, Pappus starts his classification by listing plane problems, namely problems solved by means of straight lines and circles. These curves, it is asserted in the *Collection*, have both their genesis in the plane.

Pappus might not be referring, for these definitions, to Euclid’s *Elements*, in which the straight line and the circle are not defined with a direct reference to their ‘genesis in the plane’.²⁰ On the contrary, it is possible that Pappus alluded to other works²¹ in which straight lines and circles were introduced by specifying their generation. A case at point is, for instance, the definition of circle that we encounter in a treatise on geometric definitions that was attributed to Hero of Alexandria (a scholar from III century A. D). According to Hero, indeed, a circle is described by a segment rotating in a plane

¹⁷Pappus [1876-1878] vol. I, p. 271; Sefrin-Weis [2010], p. 144.

¹⁸This characterization of genus might be borrowed from the contemporary philosophical literature. For instance, in Porphyry’s *Isagoge*, an Introduction to Aristotle’s *Categories*, we read: "Thus we call a genus an assembly of certain people who are somehow related to some one item and to one another" (§ 1, 18, see Poprhyry [2003], p. 3).

¹⁹It should be pointed out that, in the philosophical literature, the term ‘genus’ could also be used in order to denote a collection of items having a common origin, or genesis, for instance a collection of individuals grouped by having one and the same precessor (see Poprhyry [2003], p. 3). Therefore, once again, Pappus might have borrowed the term from the contemporary philosophical usage of these terms.

²⁰Euclid defines the line as a "breadthless length" (df. 3) and the straight line as "the line which lies evenly with the points on itself" (df. 4) and the circle as: "a plane figure contained by one line such that all the straight lines falling upon it from one point among those lying within the figure are equal to one another" (df. 15).

²¹The coexistence of several traditions is confirmed by Proclus, who surveys, in his Commentary to the first Book of the *Elements*, several definitions and classifications of line, including the straight line (*cf.* Proclus [1992], p. 84ff.).

around one of its extremes.²² On the other hand, the same author offers the following definition of a straight line: "that line which, when its ends remain fixed, itself remains fixed when it is, as it were, turned round the same plane".²³ Thus Hero does not give a genetic definition of straight line, but characterizes it with a reference to the plane, as he specifies that such a line remains fixed in the same plane, provided its ends remain fixed.

The second genus contains solid problems, solvable by intersection of one or several conic sections, which have their genesis in the cutting of a circular cone or a cylinder by a plane.²⁴ As we know, these curves allow us to solve two of the major problems untreatable by Euclidean means: the trisection of the angle and the insertion of two mean proportionals, which could be solved, for instance by the intersection of a circle, or a parabola and an hyperbola.²⁵

Finally, the third kind of problems does not seem to possess well-defined features, but rather to collect problems which apparently require, for their solution, curves different from circles or conic sections, for which two different modes of genesis are contemplated in Pappus' account: either they are generated either out of "less structured surfaces" than the cone, or out of "twisted motions", as we read in the *Collection*. In the subsequent lines, Pappus mentions some of these curves:

... the line that was also called "the paradox" by Menelaus. And of this same kind <i. e., the linear kind> are also the other spiral lines, the quadratrices and the conchoids and the cissoids.²⁶

On the same subject, we read in Book III that the curves belonging to the third kind of geometry are: "Helices or spirals (...) quadratrices, conchoids or conchiforms, cissoids,

²²Cf. Heath's Commentary in Heath [1956 (first edition 1908)], p. 189.

²³Cf. Heath's Commentary in Heath [1956 (first edition 1908)], p. 168.

²⁴Let us remember that in the first book of the *Conics*, Apollonius introduces our familiar conic sections as curves generated by the intersection of a plane with a double oblique circular cone: a cone with a circle as its base, and with a vertex whose projection on the plane of the circular base does not necessarily coincide with the center of the circle. The name 'solid', therefore, refers to the generation of these curves from the cone, a three dimensional figure. In Pappus' time, the class of solid lines was probably already well-grounded in the tradition (see in particular Cuomo [2007], p. 157; Sefrin-Weis [2010], p. 272)."

²⁵For the trisection of an angle, see chapter 2, p. 106. For what concerns the mean proportionals problem, its construction through a parabola and an hyperbola is attributed to Maenechmus: see, for instance, Eutocius' Commentary to the *Sphere and the Cylinder* (in Archimedes [1881], vol III, p. 93). For a modern commentary, see: Heath [1981], p. 251ff.

²⁶Sefrin-Weis [2010], p. 145. Pappus [1876-1878], vol. I, p. 271.

or curves similar to ivy-leaves ...".²⁷

Pappus mentions several sources where problems of the third kind were studied and solved; but since all these cited works are no longer extant, our reconstructions of the features of problems and curves of the third kind are irremediably conjectural and based on the sole few examples mentioned in the *Collection*. Some of the lines of the third kind mentioned by Pappus are of uncertain identification,²⁸ although the description of other relevant curves of the same genre survived in the work of ancient mathematicians, as in the already mentioned Pappus himself or in Archimedes, and through them, entered pervasively the practice of early modern geometers.

The ordering of curves presented by Pappus may offer a hierarchy based on the complexity of their genesis. Although in the *Collection* there are no references to complexity as a criterion chosen in order to distinguish plane, solid and linear curves, such considerations may not have been extraneous to ancient geometers, and particularly to Pappus himself.

Let us start by considering the straight line and the circle. As it has been observed in the secondary literature, these curves had a privileged status in ancient mathematical practice, presumably on both pedagogical, methodological and philosophical grounds.

As an illustration of these thesis, we may evoke the classical study by H. Hankel, *Zur Geschichte der Mathematik in Altertum und Mittelalter* (1874), in which it is suggested that the straight line and the circle were the only geometric means of construction accepted by ancient geometers, precisely on metaphysical grounds, as a consequence of the influence of Plato's philosophy over ancient mathematical practice. Hankel's thesis, which had a vast resonance among late XIXth and XXth century historians of mathematics, is certainly overrestrictive: later studies²⁹ have established that both pre-euclidean geometers and geometers of the hellenistic period had no qualms in employing higher curves and several methodologies in order to solve problems untreatable by the straight line and circle.

²⁷Pappus [1876-1878], vol. I, p. 55.

²⁸An example quote before is the "paradox" of Menelaus, whose nature is still controversial. Paul Tannery proposed the attractive (but ungrounded) conjecture that the paradoxical curve of Menealus could be Viviani's curve, a three dimensional curve generated by the intersection of two solid surfaces (Tannery [1883], p. 289-291). It does not seem, however, that the reading of Pappus had any role in the discovery of Viviani, which occurred in late XVIIth century.

²⁹*Cf.* in particular the outstanding seminal work Steele [1936].

However, an undeniable preference for the straight line and the circle can be found on the side of philosophers, although it is not clear how far these philosophical views penetrated into the mathematical practice of mathematicians of antiquity or late antiquity. Such a philosophical predilection for the straight line and the circle is still evident in later authors as Proclus, who conceived, in his Commentary to the first Book of the *Elements*, these lines as the "simplest" and "most fundamental" geometric items. Their geometrical primacy was well grounded in Proclus' neo-platonic philosophy: the circle represented, among geometric figures, the metaphysical principle of the "Limited", and the straight line exemplifies the metaphysical principle of the "Unlimited". Eventually, the combination of these fundamental lines generates all the other "mixed" lines.³⁰

In particular, Proclus considered the circle: "the first and simplest and most perfect of the figures (...) superior to all solid figures because its being is of a simpler order, and it surpasses other plane figures by reason of its homogeneity and self-identity".³¹ This opinion is rooted in a classical view, to be found in Plato (summoned by Proclus himself in the *Commentary*), and in Aristotle, according to which the circular shape and motions embody the perfect and primary shapes and motions.³²

But the preference for constructions requiring the straight line and the circle could be justified on purely mathematical or pedagogical grounds too. As Proclus, once again, notices, straight lines and circles can be considered the simplest lines not only on metaphysical grounds, but on epistemic ones, because "most people have a conception [of them] without being taught" (Proclus [1992], p. 96).

Moreover, straight lines and circles might have been considered 'elementary' geometric objects, in the sense that they did only require Euclid's plane geometry, in order to be studied and understood, without the necessity of having recourse to higher theories, like that of conic sections.³³ The elementary aspect of circles and straight lines is stressed by Proclus too, when he remarks that the problem of trisecting an acute angle can be obtained by higher, 'mixed' lines, and it is therefore: "difficult for a beginner to follow".³⁴

³⁰Proclus [1992], p. 84. On the problem of the generation of mixed lines, see below, section 2.3.4.

³¹Proclus [1992], § 147, p. 117.

³²See Proclus [1992], p. 14. Remarks on the circle as the simplest and most perfect shape can be found, in Aristotle's corpus, in *Metaphysics*, 1078a, 10-13 and *De Caelo*, 268b, 15-17.

³³Both points are clearly made in Roque [2012], p. 161. See also Heath [1981], p. 175-176.

³⁴Proclus [1992], p. 212.

In this sense, constructions requiring the sole ruler and compass, namely plane constructions, could have been considered, by mathematicians from late antiquity, simpler than constructions involving higher means, solid or linear curves, that were conceived as composed out of the former, and therefore a subject matter for advanced studies.

2.2.1 A conjecture about the origin of Pappus' classification of problems

A conjecture on the origins of Pappus' classification of problems has been advanced by A. Jones (see Pappus [1986], vol. 2, especially pp. 395-396, and p. 539) and tackled by W. Knorr (in Knorr [1986], p. 344*ff.*). Let us observe, in fact, that Pappus also evoked, in Book VII of the *Collection*, a classification of loci related to the classification of problems and curves expounded in Book IV.

The mathematical concept of 'locus' (τόπος) in Greek geometric practice is of difficult characterization, and Pappus does not provide any definition. He rather presents the following sketchy ordering of 'loci', whose analogy with the classification of problems in Book IV has been duly underlined in the secondary literature:³⁵

The loci about which we are teaching, and generally all that are straight lines or circles, are called 'plane' (επίπεδοι); all those that are sections of cones, parabolas or ellipses or hyperbolas are called 'solid' (στερεοί); and all those loci are called 'curvilinear' (γραμμικοί) that are neither straight lines nor circles nor any of the aforesaid conic sections.³⁶

I remark that the terminology here employed is consistent with the one used, in Book IV of the *Collection*, for the distinction into problems (Jones chooses to render the Greek 'γραμμικοί' with the word 'curvilinear', whereas the translation by Sefrin-Weis has privileged: 'linear'), and is telling of a more substantial analogy between the two classifications.

It is important to point out that the concept of locus in ancient Greek mathematics (or at least, in the geometry of the late antiquity, to which our main sources on this issue belong) differs in an important respect from the modern one.

³⁵See, for instance, Knorr [1986], p. 342.

³⁶Pappus [1986], vol. 1, p. 104.

Our modern understanding of locus is forged by the development of analytic geometry and by the germane concept of equation. It is, at its core, a set, or collection of points satisfying some conditions.³⁷ On the contrary, in ancient mathematics, as Jones clearly explains: "a locus is (...) not the aggregate of all possible points or lines subject to specified conditions, but a definable geometrical object, on which any point or line satisfying the conditions will be found, and such that any point that lies on the object will satisfy the conditions of the problem ... The 'solution' or 'demonstration' of a locus is the construction of that object, and proof that is indeed the locus".³⁸

Hence, a locus-problem may be understood as a proposition asking to construct a geometric object,³⁹ given one or more geometric objects (point or lines), with respect to which any point on the object to be constructed must obey particular conditions; and conversely a locus-theorem can be defined as: "a proposition asserting that all objects of a specific kind (points, straight or curved lines, solids) that satisfy certain given conditions (...) lie on or are part of some determined object, the 'locus'".⁴⁰ An example of solid locus-theorem is evoked by Proclus:

The parallelogram inscribed in the asymptotes and the hyperbola are equal, for the hyperbola is clearly a solid line, since it is a section of the cone.⁴¹

This is proposition 12 of the second book of Apollonius' *Conica*, that I quote here in Heiberg's version (Apollonius [1891-1893]):

Si ab aliquo puncto sectionis duae rectae ad asymptotas ducuntur angulos quoslibet efficientes, iisque parallelae ad aliquo puncto sectionis ducuntur, rectangulum retis parallelis comprehensum aequale erit rectangulo comprehenso rectis, quibus parallelae ductae sunt.⁴²

³⁷In today practice, a locus may be defined as: "Any system of points, lines or curves, which satisfies one or more given conditions" (in Robert [1992]).

³⁸Pappus [1986], vol. 2, p. 395.

³⁹This object could be a curve, a surface or a point: see Pappus [1986], vol. 2, p. 540. I will not enter here this further distinction concerning the nature of the locus, as I will confine myself to curves: another example of locus' problem, namely the problem of Pappus, will be discussed in the sequel, since it will have a pivotal role in the development of cartesian geometry.

⁴⁰Pappus [1986], vol. 2, p. 539.

⁴¹Proclus [1992], p. 311.

⁴²In Heath's paraphrase: "If Q, q be any two points on a hyperbola, and parallel straight lines QH, qh be drawn to meet one asymptote at any angle, and QK, qk also parallel to one another, meet the other asymptote at any angle, then: $HQ \cdot QK = hq \cdot qk$ " (Heath [1896], p. 59).

I note that this proposition was not presented as a locus-theorem by Apollonius, but it was interpreted in these terms by Proclus. In other words, by enunciating that any point on an hyperbola displays the property proved above, this theorem was understood by Proclus as characterizing the hyperbola by means of a condition to which its points obey (I also remark that this condition *is not* the symptom, or fundamental property of the hyperbola). This boils down to characterize the curve as a locus: a solid one, in particular, since the hyperbola is a curve generated by cutting a solid. Constructing the locus, in reverse, would mean to construct the hyperbola whose points satisfy the locus-property enunciated in the theorem above.⁴³

In the light of this explanation, it seems that the classification of loci proposed by Pappus entails an analogous classification of locus-problems too. Accordingly, plane locus-problems will result into the construction of a straight line or a circle, solid-locus problems into the construction of a conic sections, and so on. As observed by Knorr, this is a descriptive classification of problems, since it is based on a classification of curves on the ground of their genesis, and the solution of a locus-problem is always a unique curve.⁴⁴

However, when we pass from a classification of locus-problems to a more general classification of geometric problems, as the one presented by Pappus in Book III and IV of his treatise, logical difficulties emerge. For instance, in the cases of the problem of trisecting a general angle, or of the problem of inserting two mean proportionals it is required, as Pappus' discussion amply shows, to construct one or more segments by the intersection of curves (or by other solving methods). In the context of these problems, curves did not enter as solutions, but as means in order to obtain these solutions. These means should be selected among several, available ones, and a problem solved by curves of a certain kind could be often solved by curves of a different kind. On the contrary, the wrong choice of solving means may lead to no solution at all. These difficulties related to the problem, or metaproblem of establishing the adequate solution to a specific problem might have justified the normative aspect of Pappus' classificatory scheme, that I shall consider in the next section.

⁴³This example of locus-theorem is discussed, in particular, in a conference paper written by S. Unguru and M. Fried, as part of an ongoing project with Michael Fried on Geometrical Loci in Hellenistic Mathematics (see [Unguru and Fried]).

⁴⁴F. Acerbi remarks that questions of unicity and existence are not so easily separable. According to him, ancient accounts about locus-problems, as Pappus' one, took for granted the uniqueness of the locus: the property in terms of which a curve must be constructed always determine a unique solution, if the problem is well formulated. See Euclide [2007], p. 464.

2.2.2 Normative aspects in Pappus' classification

The classification in Book IV is introduced, so Pappus relates, in order to explain the difficulties occurred to the ancients when they tried "to trisect a given rectilinear angle". An analogous classification is tackled in Book III (Pappus [1876-1878], vol. I, p. 55) after a preliminary discussion about a misgiven attempt to solve the problem of inserting two mean proportionals by means of plane methods (see ch. 1, section 1.4).

In Book IV, Pappus addresses the trisection of the angle, in the foreword to his classification of problems, as a problem the ancients could overcome only with difficulty. Later on, Pappus relates in these terms about the 'difficulties' met by the ancients in solving such problem:

... the earlier geometers were not able to find the above mentioned problem on the angle, given that it is by nature solid, and they sought it by means of plane devices. For the conic sections were not yet common knowledge for them, and on account of this they got into difficulties. Later, however, they trisected the angle by means of conic sections.⁴⁵

Failures in solving the trisection problem by means of plane methods are thus related, in the account offered by Pappus, to a misunderstanding about the essence of the problem and to a still imperfect knowledge of conic sections. The problem could be solved - so we read in the *Collection* - once a sufficient knowledge of conic sections was acquired.⁴⁶ More general constraints on the appropriate methods employable in solving mathematical problems are set by Pappus himself, in the course of the same discussion:

Somehow, however, an error of the following sort seems to be not a small one for geometers, <namely> when a plane problem is found by means of conics or of linear devices by someone, and summarily, whenever it is solved from a nonkindred kind, such as is the problem on the parabola in the fifth book of Apollonius' Conics and the neusis of a solid on a circle, which was taken by Archimedes in the <book> about the spiral.⁴⁷

⁴⁵Sefrin-Weis [2010], p. 146; Pappus [1876-1878], vol. I, p. 273.

⁴⁶Of course, it must be recalled that certain trisections are perfectly possible by straight lines and circles: for instance, a right angle can be trisected by plane methods. This case was singled out by the ancients, as proved by Pappus, in prop. 32 (Pappus [1876-1878], vol. 1, p. 276). However, it is disputable whether Pappus (and more generally, ancient geometers) possessed a method in order to single out those angles trisectable by plane means, which is generally done by means of algebra.

⁴⁷In Sefrin-Weis [2010], p. 145; Pappus [1876-1878], vol. I, p. 271. I remark that there is not an analogous requirement in Book III of the *Collection*.

At its face value, this requirement enjoins that a problem solvable by straight lines and circles (namely a plane problem), should not be solved by conics or by linear curves and, more generally, that a problem should not be solved by an improper kind of curves. For this reason, H. Sefrin-Weis refers to Pappus' predicament as an 'homogeneity requirement' (Sefrin-Weis [2010], p. 273).

After having recalled the attempts to solve solid problems by plane means, Pappus cites two examples of problems that were solved "by a nonkindred kind of curve", thus violating the homogeneity requirement. The first one concerns, in Pappus' words: "the problem on the parabola in the fifth book of Apollonius' *Conics*". Scholars agree in identifying this problem with the one, discussed by Apollonius in *Conica*, book V, 51, of constructing the normal ED (in fig. 2.2.2) to a given parabola, with vertex in A and *latus rectum* equal to OB , from a point E outside it.⁴⁸In the extant version in Book V, this problem is solved by intersecting the given parabola with a hyperbola (passing through points E and D in the figure) and thus falls within the category of solid problems, according to Pappus' classification. But the same construction can be also effectuated by employing a circle instead of an hyperbola. Although no ancient sources leave trace of this procedure, we can conjecture that its discovery was in the purview of Greek mathematicians.⁴⁹ If the parabola is supposed given, only a circle is required in order to solve the problem of constructing the normal to a given parabola. Hence the problem should be considered plane, according to Pappus' scheme.⁵⁰

⁴⁸For an english paraphrase, see Heath [1896], p. 182. For the relations between this proposition and Pappus' statement, see, for instance Zeuthen [1886], p. 286, Heath [1896], p. cxxviii, Sefrin-Weis [2010], p. 274. An exception is represented by Hultsch, who relates this passage to the first Book of Apollonius' *Conica* (see Pappus [1876-1878], vol 1, p. 273). I recall that *latus rectum* and *latus transversum* are latin terms for certain line segments entering the defining properties of conic sections. With hindsight, let us suppose that the X -axis coincides with the axis of the conic, and the Y -axis is taken perpendicular to it, while the vertex of the conic section coincides with the intersection point of the axis. The *latus rectum* a and the *latus transversum* b enter in the analytical equations of the conics in this way: $x^2 = ay$ (parabola); $y^2 = ax - \frac{a}{b}x^2$ (ellipse); $y^2 = ax + \frac{a}{b}x^2$ (hyperbola). For the case of the parabola, the *latus rectum* is, in a terminology closer to Apollonius, the segment a such that, if is a point B on the parabola, C the corresponding point on the axis, and A the vertex, the following proportion holds: $AC : CB = CB : a$.

⁴⁹*Cf.* Heath [1896], p. cxxviii-cxxxix.

⁵⁰I note that Huygens seems to be the first who advanced this interpretation of Pappus' passage (Huygens [1888-1950], vol. 3, p. 61, vol. 12, p. 81-82). Huygens' remarks about the construction of the perpendicular to a parabola were not published, but they were known, and mentioned, for instance, by van Schooten in his commentary to Descartes' *Géométrie*: "... we can suggest the problem of Apollonius on the parabola, in the fifth Book of the *Conics*, that Pappus from Alexandria recalls in the *Scholium* of his proposition 30 of the fourth Book of the *Mathematical Collection*." see for instance: Descartes [1659-1661], vol. 1, p. 322-324

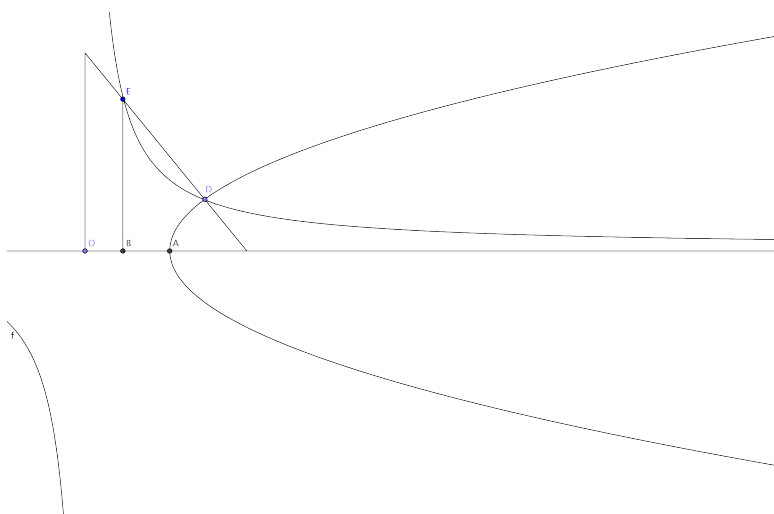

Figure 2.2.1: The normal to a parabola.

In the second example of solutions violating his precept, Pappus evokes a solid *neusis* "taken by Archimedes in the <book> about the spiral". Despite Pappus' remark is poorly informative, it is generally accepted that Pappus was referring here to the problem of determining whether a *neusis* employed in propositions 7, 8 of Archimedes' treatise on *Spirals*, and successively employed in proposition 18 of the same work, was constructable by solid or plane means.⁵¹ I shall not enter into the details of this construction which, contrarily to the case of the normal to the parabola, was not discussed during XVIIth century, but I confine myself to pointing out to the likely analogy between these two examples of erroneous understanding of the kind of a problem. It seems, indeed, that the question at stake, in both the cases cited by Pappus, concerns attempts to demarcate plane from solid problems, by arguing that a problem known to have been by means of conic sections could be indeed solved plane methods, entailing that it was a plane problem, in the end.

I observe that neither solving a plane problem by means of a solid or linear curve, nor solving a solid problem by means of a linear curve constitutes *per se* a technical error, nor it was understood as a technical error by Pappus himself. This fact can be illustrated by an example discussed in the *Collection*: even if it seems that Pappus had no doubts about the solid nature of the problem of inserting two mean proportionals,⁵² he still accepted, probably for reasons of practicality, a solution to this problem based on a

⁵¹Sefrin-Weis [2010], 302ff; Knorr [1986], p. 176-178.

⁵²Pappus [1876-1878], vol. I, p. 55, p. 271.

neusis constructable by means of a linear curve, namely the conchoid (*Collectio*, book IV, proposition 23).

On the other hand, Pappus' requirement can be read as including another sort of error. As I have discussed the introduction of this study, in fact, it was also considered unwise to attempt employing plane means in order to solve a solid problem. Pappus cites examples of such flawed attempts, both in Book III (as we know: see ch. 1, p. 28) and more succinctly in Book IV (with the case of the trisection of an acute angle).

From today perspective, this error stems from a mathematical impossibility. Certainly Pappus might have suspected that solid problems could not be solved by plane means. However, it should be pointed out that Pappus never explicates such a conjecture, but confines himself to declare, without explanation, the solid nature of certain problems. Pappus' requirement can be conceived as a norm, whose rationality was ingrained in the mathematicians' practice and was justified both by a long record of failed attempts, and by a tradition of studies dealing with a certain class of problems, like solid ones. Therefore we could qualify any violation of Pappus' requirement as a 'metatheoretical misbehaviour',⁵³ either in the sense of solving a problem by a more complex curve, or in the opposite sense, of trying to solve a problem by a too simple one.

We can also inquire whether Pappus' classification and requirement were known in the context of Greek mathematics, and whether Pappus possess a general methodology in order to decide whether this requirement had been met, or a method in order to decide the class of a problem as plane, solid or linear.

As for the latter question, scholars tend to limit the influence of Pappus' requirement and of his classification upon ancient Greek mathematics. It seems, in fact, that: "Pappus is the only explicit authority on this mathematical pigeon-holing, and says nothing about how it developed, or when".⁵⁴ On the other hand, it can be ventured the hypothesis that the possibility of associating one solution only to each given problem was still preferred, at least in late antiquity, to the usual situation of a mathematical practice, in which a problem could be tackled and solved by using several methods. For instance, Proclus does not hesitate in judging solutions of problems which "can be effectuated in only one way" more "elegant" than constructions which can be effectuated in finitely many or

⁵³The expression can be found in Høyrup [2001], p. 242.

⁵⁴[Pappus, 1986], vol. II, p. 530. See also Knorr [1986], p. 345, 348.

indefinitely many ways.⁵⁵ If read in this context, Pappus' requirement might have been viewed as a prescription aiming towards a more 'elegant' problem solving practice, where by 'more elegant' one might understand a less time-consuming and more easily cognizable to the intellect.

For what concerns the former issue, namely the question whether methods for deciding the nature of problems had been developed in ancient mathematics, it can be argued that despite Pappus' precept being readable as a strict directive on the adequate or legitimate kind of geometrical constructions for a given problem or a given collection of problems, it seems to be hardly workable in the context of Greek mathematics. Indeed, if it is sufficient to solve a problem by plane means in order to classify it as plane, it is not equally sufficient to solve a problem by solid or linear lines in order to range it into the correspondent category. In order to have a mathematically sound classification, one should be able to find a solution for a problem at hand, and then prove that the problem is not solvable by means belonging to a lower class than the class of lines which actually solve it. However, the methods ultimately worked out in order to classify problems on the ground of their solvability crucially depend on algebraic techniques unavailable to Greek mathematicians.⁵⁶

However, Pappus' classificatory scheme might be interpreted, instead of an abstract classification of types of geometric objects (i. e. problems), according to their solutions, as an attempt to organize and describe the scattered, or only partially ordered material that came down to Pappus from a long tradition of problem-solving. Consistently with this interpretation, the three 'genera' or kinds of problems might be as well envisioned as three distinct traditions in geometry, either pre-existent Pappus' compilative effort, or conceptualized by Pappus himself on the ground of previous material, in order to have a grip on the variety of results consigned by ancient geometers.⁵⁷ According to this historical reading, Pappus was describing a practice evolved in the tradition of problem solving, and the requirement of solving each problem according to its own kind mirrored such a tradition.

⁵⁵Proclus [1992], p. 172-173.

⁵⁶Knorr [1986], p. 347; see also chap. 1, p. 1.4. In the same vein, H. Sefrin Weis remarks that: ". . . Pappus' general homogeneity requirement was not fully developed, or integrated, into geometry, it seems. Pappus' meta-theory claims more than the practice, or the theory, could do".Sefrin-Weis [2010], p. 274-275.

⁵⁷Sefrin-Weis [2010], p. 271-272, and in particular, Cuomo [2007], p. 151ff.

Then how are we to understand Pappus' requirement, in the light of this interpretation? As I have also observed in chapter 1 of this study, geometers from late antiquity shared a tradition of commentary and research on topical problems, like the problems collected in Euclid's plane geometry, or the trisection of the angle and the duplication of the cube (i.e. the insertion of two mean proportionals), considered as solid 'by nature', and therefore outside of the problem-solving technique adopted in the *Elements*. I surmise, in other words, that later geometers, like Pappus, identified the trisection and the cube duplication problems with a veritable tradition of problems, that we can label "solid geometry", characterized by the correlative development of special methods for their solutions, namely conic sections. We can thus conjecture that it would have been sufficient to prove that a certain problem, apparently not related with either the trisection of the angle or the insertion of two mean proportionals, was reducible to either of them, in order to ascribe it to the same tradition, and thus construct it by the methods allowed within this tradition.

Conclusively, any decision about the plane, solid or linear nature of a problem ultimately depended on how the mathematical tradition had treated the problem at hand: this would determine, or contribute to determine, the 'nature' of a problem in the eyes of a late-antiquity thinker as Pappus.

This interpretation may also explain the peculiar characteristic of problems of the 'linear' kind. It is doubtful, indeed, whether linear problems and curves may be said to form a 'kind', in analogy with the other two kinds of problems. Standing to Pappus' account, indeed, these problems and curves seem to be identifiable in no other way than by their otherness: Pappus groups in one class those geometrical problems irreducible either to plane or solid ones, and these curves whose genesis is more complex than straight lines, circles and conic sections.

Moreover, there is little doubt that linear problems and curves constituted a vast (certainly vaster than the examples survived till us) but not-fully understood subject, even in Pappus' time, probably a subject matter of which mathematicians had cognizance, but not complete domain. In the light of this situation, Cuomo [2007] claims that: "... Pappus' main focus [in the *Collection*] is to present the curves as successful problem-solving tools, whose utility is proved by applying them to a number of constructions, and whose homogeneity is underscored by streamlining their definitions and the descriptions

of their main properties".⁵⁸

It is arguable, standing to Cuomo's observations, that one of Pappus' purposes (or even his main purpose) in presenting the third kind of geometry as he did in the *Collection*, might have been that of giving legitimacy to curves thus far considered poorly familiar, or 'exotic' by the mathematical tradition of antiquity and late antiquity, because of their complex descriptions (below, I shall offer some examples of these complex curves) and of their unclear employment in problem-solving.

2.3 Curves and problems of the third kind

When Pappus' *Collection* circulated in latin, by the end of XVIth century, the problem solving practice that Pappus might have direct or indirect endorsed was for the most part lost. Consequently, the question about the applicability of Pappus' classification of problems came utility and to the fore again, with urgency. I will discuss this theme and the developments that it gave rise to in chapters 3 and 5.

As we shall meet problems and curves of the third kind on several occasions in this study, it is worth describing in more detail the definitions and properties of the best known among them, following the account offered in surviving ancient texts, in particular Pappus' *Collection*.

2.3.1 The conchoid

One of the most important curves of the third kind mentioned by Pappus is the conchoid, described in Book IV of the *Mathematical Collection* in connection with the two mean proportionals problem. The conchoid will become, in XVIIth century geometry, a familiar curve to mathematicians, to the point that it will be mentioned twice in Descartes' *Géométrie* as an example of a curve properly geometrical (see chapter 3, p. 3.2.1) contra Pappus, who considered it a linear curve on the ground of its genesis:

Set out a straight line AB , and a <straight line> CDZ at right angles to it, and take a certain point E on CDZ as given. And assume that, while the point E remains in the place where it is, the straight line $CDEZ$ travels along the straight line ADB , dragged via the point E in such a way that D travels on the straight line AB throughout and does not fall outside while

⁵⁸Cuomo [2007], p. 167-168.

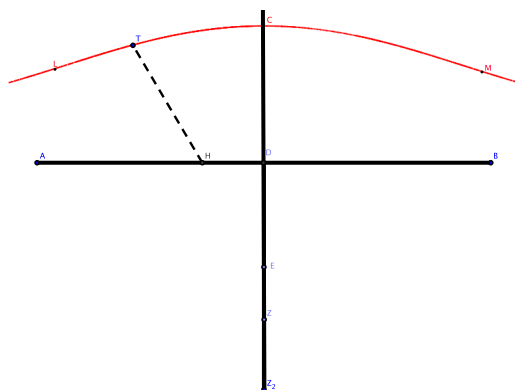

Figure 2.3.1: Conchoid.

$CDEZ$ is dragged via E . Now, when such a motion takes place on both sides, it is obvious that the point C will describe a line such as LCM is, and its symptoma is of such a sort that, whenever some straight line <starting> from the point E toward the line meets it, the <straight line> cut off between the straight line AB and the line LCM is equal to the straight line CD . For, while AB remains in place, and the point E remains in place, when D comes to be upon <a point> H , the straight line CD reaches HT , and the point C will fall onto T . Therefore, CD is equal to HT . Similarly, also, whenever some other line <starting> from the point E toward the line meets <it>, it will make the segment cut off by the line and the straight line AB equal to CD .⁵⁹

As we can read in the above passage, Pappus illustrates the generation of the conchoid starting from a fixed couple of axis CZ and AB , perpendicular one to the other. Then, he marks a point D , intersection point of the axis, and on CZ he marks another point E , that will be maintained fixed during the generation of the curve. Its genesis is in fact obtained by pivoting the straight line $CDEZ$ around point E (“dragged via point E ”, Pappus writes), in such a way that point D is carried along the axis AB and, as Pappus remarks, “does not fall outside” this axis. Point C , which is carried along in this motion, will eventually describe a conchoid, as it is shown in figure 2.3.1.

⁵⁹Sefrin-Weis [2010], p. 126. Pappus [1876-1878], vol. I, p. 243-44.

In the subsequent lines, Pappus recalls that this curve can be traced ‘ $\acute{\omicron}\rho\gamma\alpha\nu\iota\chi\tilde{\omega}\zeta$ ’,⁶⁰ that is, by the aid of an instrument. Eutocius’ commentary on Archimedes’ treatise *On the Sphere and the Cylinder*, offers the description of a suitable device for the tracing of the conchoid: this instrument is conceived simply by converting Pappus’ description into a mechanism forming by two perpendicular fixed rulers, and a third sliding one, as in figure 2.3.1 (the bold lines can be taken to represent the components of the instruments).

The fundamental property of this curve, namely its *symptoma*,⁶¹ can be easily inferred from the description given in the *Collection*. In fact the conchoid is generated in such a way that the distance CD remains fixed during the motion. Therefore, any segment HT intercepted on the pivoting line CDZ between the curve and AB is equal to CD . This property obviously foreshadows the possibility of using the conchoid to mark segments of given length, and therefore to employ this curve, or the compass employed for its tracing, in order to perform a *neusis* construction.⁶²

2.3.2 The Quadratrix

The curve known as ‘quadratrix’⁶³ is described in the fourth book of the *Mathematical Collection* (§ 25-26):

Set out a square $ABCD$ and describe the arc BED of a circle with center A , and assume that AB moves in such a way that while the point A remains in place, <the point> B travels along the arc BED , whereas BC follows along with the traveling point B down the <straight line> BA , remaining parallel to AD throughout, and that in the same time both AB , moving uniformly, completes the angle BAD , i.e.: the point B <completes> the arc BED , and BC passes through the straight line BA , i.e.: the point B travels down BA (...). Now, while a motion of this kind is taking place, the straight lines BC and BA will intersect each other during their traveling in some point that

⁶⁰The word is translated with *instrumentaliter* by Commandinus ([Commandinus, 1588], 56r).

⁶¹The notion of *symptoma* of a curve is thus explained by Sefrin-Weis: "In order to study the mathematical properties of such curves, one has to come to a quantifiable characterization, as a proportion, or an equality that applies to all the points on the curve and only to them. All mathematical properties have to be derived from, or related back to, this original characterizing property. It is called the *symptoma* of the curve", (in Sefrin-Weis [2010], p. 223).

⁶²An example of a *neusis* obtained via a conchoid is explained in prop 23 of book IV (Sefrin-Weis [2010], p. 127-128; Pappus [1876-1878], I, 247-248).

⁶³Its attribution is controversial, as the names of several pre-euclidean geometers (Hippias, Nicomedes, and Dinostratus, for instance) are associated to it by the commentators (see Folkerts, Menso (Munich). "Quadrature of the circle." Brill’s New Pauly. Antiquity volumes edited by: Hubert Cancik and , Helmuth Schneider. Brill Online, 2013).

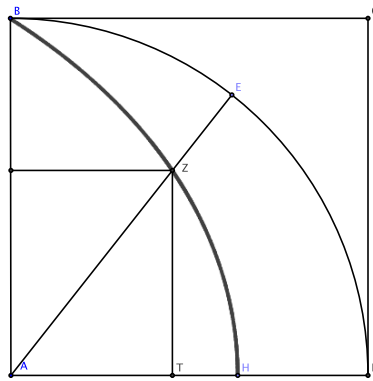

Figure 2.3.2: The quadratrix.

is always changing its position together with them. By this point a certain line such as BZH is described in the space between the straight lines BA and AD and the arc BED , concave in the same direction <as BED >, which appears to be useful, among other things, for finding a square equal to a given circle.⁶⁴

As Pappus explains, the quadratrix BZH (fig. 2.3.2) is traced by the moving point Z , intersection between the segment AE which pivots with uniform velocity around the centre A of the circle and the segment BC , which moves uniformly along the vertical direction BA during the same time-interval. The symptom of the curve, as Pappus relates, is expressed by the following property:

Whichever arbitrary <straight line> is drawn through in the interior toward the arc, such as AZE , the straight line BA will be to the <straight line> ZT as the whole arc < BED is> to the arc ED .⁶⁵

In other words, the quadratrix has the property that for any two points on it, their distances from the given straight line AD are in the same ratio as the angles formed by the lines that join them to the center of rotation of the pivoting radius and AD . As I will discuss in the next session, thanks to this fundamental property the curve can be

⁶⁴Sefrin-Weis [2010], p. 131. Pappus [1876-1878], vol. I, 253.

⁶⁵Sefrin-Weis [2010], p. 132; Pappus [1876-1878], vol. I, 253.

immediately employed to solve the problem of dividing an arbitrary angle into a number n of equal parts.

Moreover, as its very etymology recalls, this curve can be used in order to solve another, more prominent problem: the rectification of the circumference, and therefore the squaring of the circle. Indeed, in the same book IV of the *Collection*, Pappus proves that the length of the pivoting radius AB is the mean proportional between the length of a circular quadrant \widehat{BED} and the limiting length AH , the point H being obtained when the pivoting radius AB and the shifting line BC coincide. Since, in virtue of *Elements*, VI, 11, one can construct a segment X which is the fourth proportional given the segments AH and AB , this line will be equal to \widehat{BED} . In this way, the rectification of the circumference can be solved too.⁶⁶

Already in antiquity, doubts were raised concerning the role of the quadratrix as a construction method, particularly in relation with the circle-squaring problem. For instance, after having illustrated the construction of this curve, Pappus himself related two objections attributed to a commentator named Sporus.⁶⁷

⁶⁶See below for a reconstruction of Pappus' proof. The latin term 'quadratrix' simply translates the greek: 'τετραγωνίζουσα'. The relation between the curve and the circle-squaring problem, besides being evoked by the very name of the curve, is mentioned in Pappus' account: "... For the squaring of the circle a certain line has been taken up by Dinostratus and Nicomedes and some other more recent (mathematicians). It takes its name from the *symptoma* concerning it. For it is called 'quadratrix' by them..." (Sefrin-Weis [2010], p. 131). I note that Pappus' narration appears slightly inconsistent: whereas here he seems to consider as the *symptoma* of the quadratrix the possibility of using it for squaring the circle, in the passage quoted before Pappus attributes a different *symptoma* to the same curve, namely the possibility of cutting arcs into a given proportion. One hypothesis to explain this inconsistency away would be to assume that the two problems were, for the ancient, equivalent under certain relevant aspects. This supposition is however not grounded on any evidence, except the fact that curves known to solve one problem were also known to solve the other, and *vice versa*.

⁶⁷A digression may be useful at this point, since our understanding of Sporus' passage can be sensibly different from the way in which early modern geometers understood it. Indeed Commandinus, the Latin editor and translator of Pappus' text, heavily interpolated the original passage concerning Sporus' critiques, and substituted the name of the mathematician 'Sporus' with the verb 'spero', dramatically changing the meaning of the introductory sentence, which in his version reads as: "this line - I hope - is, rightly and with merit, not satisfying ..." ("Hec autem linea spero iure ac merito non satisfacit propter haec ...", Commandinus [1588], 57v. The meaning of the whole passage resulted consequently changed: readers of Pappus in Commandinus' translation might have considered that such criticism circulated among the ancients, and was not limited to few individuals. This might help understanding, for instance, why Descartes refers generically to the 'ancients' when he relates, in *La Géométrie*, the passage of Pappus' book IV that we are examining here. Before the publication of Descartes' *Géométrie* (1637), Christophorus Clavius, one of the first, and most influential readers of Commandinus' *Collectiones*, discussed the same passage about Sporus in his second edition of his *Commentary* to Euclid's *Elements* and claimed that Pappus (and not Sporus) rejected the quadratrix as useless and not amenable to description ("... a Pappo rejiciatur, tanquam inutilis et quae describi non possit ...", Euclid [1589], p. 894). Thus, early modern readers helped spread the opinion that the view on the mechanical nature of

Sporus' twofold critique was moved against the construction of this curve by composition of motions, the same discussed by Pappus and summarized above. According to the first one, the construction of the quadratrix was inconsistent because it would be based on a circularity; in fact, in order for the moving segments to reach at the same moment the axis, the ratio of their movement had to be known in advance. But the knowledge of this ratio presupposes the knowledge of the ratio between the radius and the arc, and thus, it presupposes to have solved the rectification problem in advance.

The second objection, instead, is related by Pappus with these words:

Consider what is being said, however, with reference to the diagram set forth. For when the <straight lines> CB and BA , traveling, come to a halt simultaneously, they will <both> reach AD , and they will no longer produce an intersection in each other. For the intersecting stops when AD is reached, and this <last> intersection would have taken place as the endpoint of the line, the <point> where it meets the straight line AD . Except if someone were to say that he considers the line to be produced, as we assume straight lines <to be produced>, up to AD . This, however, does not follow from the underlying principles, but <one proceeds> just as if the point H were taken after the ratio of the arc to the straight line had been taken beforehand.⁶⁸

Contrarily to the first one, which can be forestalled, as H. Bos explains,⁶⁹ the second objection remains valid also today.⁷⁰ Therefore, the last point H could not be determined by the generation of the curve by two motions. The tracing of the quadratrix remained therefore incomplete, unless it was supplemented by a different description or one had

the quadratrix was a well accepted fact among the ancients. The opinion is held also by Tannery [1883], p. 285.

⁶⁸Sefrin-Weis [2010], p. 133.

⁶⁹Bos [2001], p. 43, notices that it is not necessary to pre-install a special ratio of velocities to construct the quadratrix. Indeed it is sufficient to start from two given segments AE and AD , and to suppose that the first of the two moves counterclockwise around A , while the second moves upward parallel to itself, both motions being uniform, starting and finishing at the same instants of time. The curve will be thus traced, and it will intersect the perpendicular to AD at A in a point B . We can therefore complete the square, and obtain the same configuration as described by Pappus. Of course, the quadratrix so conceived can be used to square the circle of radius AB , but since the ratio between the radius and the circumference (or between the square built on the radius and the circle) is constant (Euclid, *Elements*, XII, 2), once the quadrature problem is solved for the particular circle with radius AB it will be solved for any other circle.

⁷⁰If we write down the parametric equation for the quadratrix (which can be easily determined from its construction), and call θ the angle $D\hat{A}E$, formed by AD and by the sweeping segment AE , we obtain the following expressions: $x = \frac{2\theta}{\pi \tan \theta}$, $y = 2\frac{\theta}{\pi}$. Thus, the segment AH where the curve meets the horizontal axis AD can only be obtained as the limit of $\frac{2\theta}{\pi \tan \theta}$ when θ tends to zero. Such limit is $\frac{2}{\pi} = AH$.

previously found the ratio of the quadrant to the radius. These considerations induced Sporus to conclude that - so Pappus says:

... Without this ratio being given, however, one must not, trusting in the opinion of the men who invented the line, accept it, since it is rather mechanical.⁷¹

The term employed by Pappus, namely: ‘μηχανικῶς’, should be differentiated from the term ‘ὄργανικῶς’, seen before in connection with the conchoid. In the latter case, the organic character of the curve is related to its concrete tracing by an instrument. The former case is of a less easy understanding, because of the variety of possible and controversial meanings connected with mechanics, in antiquity. For the sake of my argument, I shall point out to two relevant aspects in the classical description of the quadratrix, which may be connected with its ‘rather mechanical’ nature. Firstly, the term mechanical may indicate the fact that this curve, just like the spiral and the cylindrical helix, is generated by a couple of independent motions. But the sole reference to the genesis of the curve by motions does not seem to fully explain Sporus’ intentions, in qualifying the curve as ‘rather mechanical’.

Additional information can be gleaned through from the context in which the quadratrix is judged a mechanical curve, and in particular, from the problematic aspect of its genesis, discussed above. It can be conjectured, on the ground of Sporus’ objections, that the quadratrix is qualified as mechanical, because its genesis, described in the *Collection*, does not offer an exact construction of the curve, but only an approximate one. We have seen, indeed, that the foot of the curve cannot be exhibited by the twin motions which generate it; moreover, it might not have escaped to Pappus that this point could be precisely approximated, for example, by the tracing of a smooth curve passing through the other points of the quadratrix.⁷²

These observations are relevant, particularly for the posterity of this text. Indeed the term ‘mechanical’ would continue to be used in the early modern classifications of curves and, especially with Descartes, came to denote such curves as the quadratrix, the spiral and the cylindrical helix, generated by a couple of independent motions.⁷³

⁷¹Sefrin-Weis [2010], p. 133.

⁷²Cf. Van der Waerden [1961], p. 192. A similar reasoning will be deployed, in the early modern period, in the *Commentary* written by Clavius to Euclid’s *Elements* (see ch. 5, sec. 5.2.3).

⁷³This topic shall be discussed in ch. 5.

2.3.3 The Archimedean spiral

The third curve that I want to examine is the Archimedean spiral. Pappus describes the curve in these terms:

Let there be given a circle with center B and radius BA . Assume that the straight line BA has been set in motion in such a way that, while B remains in its place, A travels uniformly along the circumference of the circle, and together with it <i.e., together with the rotating BA > a certain point, starting from B , is assumed to travel uniformly along it, in the direction of A , and assume that within the same time the point from B passes through BA and A passes through the circumference of the circle. Now, the point moving along BA will describe a line such as $BEZA$ during the rotation, and its starting point will be the point B , while the starting point of the rotation will be BA .⁷⁴

From Pappus' protocol, we gather that the spiral is, like the quadratrix, generated by a couple of motions. Indeed, given a circumference of center B , the curve is generated by a mobile point A which covers the radius BA while the latter rotates, both motions being uniform and starting at the same time. Since in Pappus' construction the circle is given, the generation of this curve falls into the same objection mentioned for the case of the quadratrix: in order to start and terminate at the same time, the motions should be synchronized according to the ratio $2\pi r : r$, and their synchronization requires the knowledge of π .

However, the same argument advanced in order to explain away Sporus' objection in the case of the quadratrix can be invoked in this case too: the knowledge of π (that is, the solution of the rectification problem) is required only when a circle is given, as in the

⁷⁴Sefrin-Weis [2010], p. 119, Ed. Pappus [1876-1878], vol. I, 235. The construction of the spiral can be continued beyond the endpoint A . It is sufficient, in fact, that segment BA makes a second rotation, with uniform velocity, while the point A travels uniformly on the segment BA extended. Since both the rotational movement and the translational one can be indefinitely protracted, we can always construct new branches of the spiral. The portion of the arc of the spiral bounded between consecutive returns of the ray to its initial position is called a "turn." Pappus limits his considerations to the one-turn spiral. Archimedes comments about the possibility of extending the spiral by iterating the same construction (see for instance, the prefatory letter to the treatise *On Spirals*, in Heath [1897], p. 154), therefore it was well known, among ancient mathematicians, that this curve could potentially intersect the straight line on which BA lies in an infinite number of times.

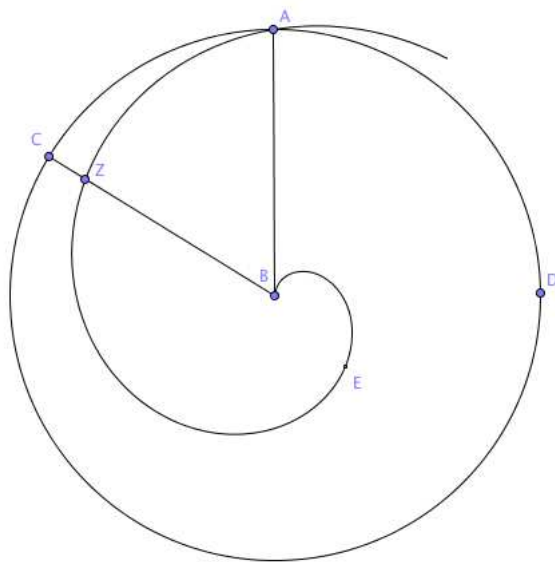

Figure 2.3.3: The Archimedean spiral.

case presented by Pappus, and a specific spiral must be traced. On the other hand, the knowledge of π is not requisite if we start the construction of the curve from a point translating on a radius rotating around one of its extremities.⁷⁵

Also for its symptoma, the spiral can be put on a par with the quadratrix:

And its principal symptoma is of the following sort. Whichever <straight line> is drawn through the interior toward it, such as BZ, and produced <to C>, the straight line AB is to the <straight line> BZ as the whole circumference of the circle is to the arc ADC.⁷⁶

The mode of generation of the spiral allows us to establish a proportion between two segments and two circular arcs (or the corresponding angles), so that the problem of dividing an angle into any given ratio can be easily solved through this curve, as I will detail later on.

2.3.4 The Apollonian helix

I will finally introduced a fourth curve, which is employed in propositions 28 of book IV in order to generate the quadratrix,⁷⁷ but never defined in this book. However, we encounter its description in book VIII of the Collection, in connection with the shape of a machine called *cochlea* ($\kappa\omicron\chi\lambda\acute{\iota}\alpha\tau$), probably employed for moving columns of water upward.⁷⁸

According to Pappus' account, the helix is generated out of the composition of two motions. Given a finite cylindrical section, this curve is traced by a point translating uniformly along a straight line, that rotates uniformly on the surface of the cylinder, in

⁷⁵The second way is followed by Archimedes in his treatise *On Spiral*, Df. 1: "If a straight line drawn in a plane revolves at a uniform rate about one extremity which remains fixed and returns to the position from which it started, and if, at the same time as the line revolves, a point moves at a uniform rate along the straight line beginning from the extremity which remains fixed, the point will describe a spiral in the plane" (Heath [1897], p. 165). As one can evince from this treatise, the spiral was also involved in the solution of the circle-squaring problem, although no explicit discussion on this concern can be found in Pappus' book IV. The connection is examined in Archimedes' treatise instead, as I will discuss in the next section.

⁷⁶Sefrin-Weis [2010], p. 119, Pappus [1876-1878], vol. I, 235.

⁷⁷See Sefrin-Weis [2010], p. 137. Pappus' intention, in generating the quadratrix from the helix, was probably to find an alternative genesis of this curve, that could circumvent the objections advanced by Sporus. In the subsequent proposition 29, in fact, Pappus shows how the quadratrix can be generated out of a complex surface, named "plectoid" (Sefrin-Weis [2010], p. 140). The plectoid here evoked is a *hapax* in ancient mathematical literature.

⁷⁸Tannery [1883], p. 288.

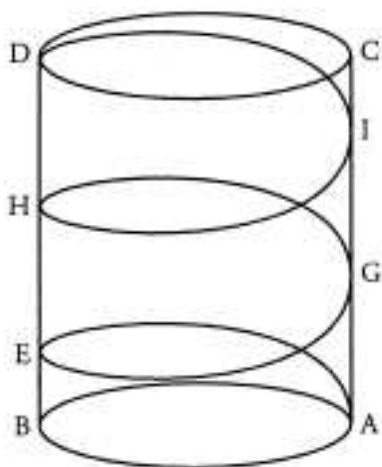

Figure 2.3.4: The Apollonian Helix.

such a way that in the same time the point has traversed the whole segment, the segment has accomplished a full rotation.⁷⁹

The same description by composition of motions can be found in other ancient mathematical texts, as in Hero's *Mechanics*, or in Proclus' *Commentary* in the first book of Euclid's *Elements*. It is worth reporting Proclus' definition, as it was also read during XVIth and XVIIth century, and clearly shows the connection between this curve, Pappus' description of the quadratrix and his description of the spiral:

the cylindrical helix is traced by a point moving uniformly along a straight line that is moving around the surface of a cylinder. This moving point generates a helix any part of which coincides homeomerously with any other, as Apollonius has shown in his treatise *On the Cochlias* (...) the very mode of generating the cylindrical helix shows that it is a mixture of simple lines, for it is produced by the movement of a straight line about the axis of a cylinder and by the movement of a point along this line.⁸⁰

The helix is thus generated by a couple of "dissimilar simple motions". By this expression, as we can understand from the context, Proclus might refer to the uniform rotations and

⁷⁹Pappus [1876-1878], vol. 3, p. 1110-1111.

⁸⁰Proclus [1992], p. 86.

traslations occurring at the same time: the kinship between the helix, the quadratrix and the spiral is thus revealed by the common mode of generation of the three curves.⁸¹

The difficulty of explaining the genesis of complex curves of the third kind in terms of elementary motions is evoked in a subsequent passage of the *Commentary*, when Proclus discusses the nature of the helix as a "mixed line".⁸²

...although a simple line can be produced by a plurality of motions, not every such line is mixed, but only one that arises from dissimilar motions. Imagine a square undergoing two motions of equal velocity, one lengthwise and the other sidewise; a diagonal motion in a straight line will result. But this does not make the line a mixed one, for it is not brought into being by a line different from itself and moving simply, as was the case of the cylindrical helix mentioned.⁸³

Although linear curves did not form a well defined group in late antiquity, we can thus spell out, on the ground of the previous quotations, a generic trait of homogeneity underscoring their characterization. Indeed, even if these curves were described in the plane, their genesis, as provided by Pappus and presented with analogous terms in Proclus, required cymematical elements (uniform rotations and translations occurring at the same time) that ancient mathematicians were not able to reduce to more elementary constructions in the plane itself, hence their 'dissimilarity' noted by Proclus.⁸⁴

⁸¹Proclus mentions the quadratrix in another locus of his commentary, referring to it as a "mixed" line as well (Proclus [1992], p. 212).

⁸²Proclus introduces a classification, ascribed to Geminus, between mixed and simple lines. This ordering of curves is different than Pappus' tripartite one, although it is still based on the mode of generation of curves (Proclus [1992], p. 90-91).

⁸³Proclus [1992], p. 86.

⁸⁴See EUCLIDE [2007], p. 104. I will not discuss here the reference, made by Pappus, to the generation of linear curves out of complex surfaces, since they had a minor role in early modern debates (see the previous footnote 44). As I have suggested, the fundamental motivation behind Pappus' choice to present these spatial constructions might have been connected to the attempts at providing a more geometrical description of curves whose genesis through motions was problematical and criticized, as the case of the quadratrix. By describing this linear curve as an intersection between two solids, in fact, ancient geometers might have tried to offer a complete description of the quadratrix, with its foot included. Pappus' attempts, however, failed to offer the crucial intersection point between the curve and the axis (see Sefrin-Weis [2010], p. 137-139). By constructing linear curves through the intersection of solid surfaces different than the cone, Pappus might have also wanted to stress the irreducibility of the curves of the third kind to the second kind, so that the constitution of a third class of curves beyond the conic sections was fully justified, on the ground that: a) the movements which produced these curves in the plane were not reducible to one rotation (producing the circle) or one translation (producing the straight line), and b) that the surfaces from which these curves could be engendered by projection or by sectioning were more complex than the cone or the cylinder, and there was no known procedure for

A possible exception among linear curves is offered by the conchoid: in the genesis of this curve, in fact, we do not encounter two motions subject to uniformity constraints; there is rather one principal motion (the swinging of the line CDE around point E), the constraint being determined by the segment of fixed pre-assigned length CD [see fig. 2.3.1]. As we know, there are mathematically meaningful reasons which underline the different geometric description of the curve, and that motivate a distinction between the conchoid and the other linear curves described above,⁸⁵ but it is plausible that these reasons passed unnoticed until the advent of Descartes' *Géométrie*, in which they are pointed out explicitly and with a critical intent.⁸⁶

2.4 Problems from the third kind of geometry

The examples of problems from the third kind of geometry treated by Pappus are discussed in propositions 26-30 of book IV of the *Mathematical Collection*, propositions 35-38 and propositions 39-41 of the same book. These three groups of propositions are centered around the following issues: the problem of the rectification of the circumference (propositions 26-30, 39-40) and the problem of the general angle division (propositions 35-39).

2.4.1 General Angle Division (*Collection*, IV, proposition 35)

The problem of the General Angular Section can be stated as follows:

Given an arbitrary angle φ and two natural numbers ρ and ϱ it is required to divide φ in two angles φ_1 and φ_2 such that $\varphi_1 : \varphi_2 = \rho : \varrho$.

This problem can be reduced to that of the division of the angle φ into $\rho + \varrho = \mu$ equal parts. In order to obtain φ_1 it will be sufficient to take a number ρ of the equal parts

obtaining these curves out of the intersection between a plane and a cone.

⁸⁵To this concern, Paul Tannery has remarked: "le rapprochement de la courbe d'Hippias avec la conchoïde, au point de vue géométrique, ne peut, d'autre part, être regardé que comme passablement forcé..." (Tannery [1883], p. 284). In modern parlance, the conchoid is an algebraic curve, that is, a curve described by a finite polynomial equation, while the quadratrix and the spiral are transcendental, that is, the relation between the abscissas and the ordinates are expressed by transcendental functions. A similar reasoning holds for the cissoid, another curve listed by Pappus as 'linear', although it is which is described by an algebraic equation.

⁸⁶"The conchoid of the ancients" is evoked, for example, in Book II of *La Géométrie* (Descartes [1897-1913], vol. 6, p. 395). As I will discuss in the next chapter, Descartes explicitly recognized that the motions which generate, according to Pappus' description, a curve like the conchoid could be reduced to an ordered succession of rotations and translations and, on this ground, the locus of the curve could be described by an algebraic equation.

obtained by the previous division, and in order to obtain φ_2 it will be sufficient to take a number ρ of equal parts.

Since Pappus' book IV represents the only extant source which mentions the problem, it is worth dealing briefly with its role in the treatise and with the methods applied for its solution. As Pappus states:

Now, trisecting a given angle or arc is a solid problem, as has been shown above, whereas dividing a given angle or arc in a given ratio is a linear problem, and while it has been shown by the more recent mathematicians, it will be shown as well in a twofold way by me.⁸⁷

As declared, Pappus gives two solutions of the problem, one through the quadratrix and the other using the archimedean spiral. Both constructions follow similar patterns, as it can be remarked from the protocols detailed below.

Solution via the quadratrix

In virtue of Euclid's *Elements*, III, 27, the problem of dividing an arbitrary angle φ into a given ratio can be reduced to the problem of dividing into the same ratio an arc of circumference, corresponding to an angle at the centre equal to φ . Pappus proceeds indeed by dividing the arc, in the following way:

Protasis: Divide an arc \widehat{LT} into the ratio $a : b$.

1. Construction:

- Complete the quadrant $BKLT$ and inscribe the quadratrix KAC .
- Draw the perpendicular AE onto BC .
- Draw point Z on AE such that $AZ : AE = a : b$.
- Draw ZD parallel to BC .
- Draw segments BD and DH , the latter perpendicular to BT .
- The arc \widehat{LM} is to the arc \widehat{MT} as a is to b .

2. Proof

⁸⁷Sefrin-Weis [2010], p. 155. Pappus [1876-1878], I, 285.

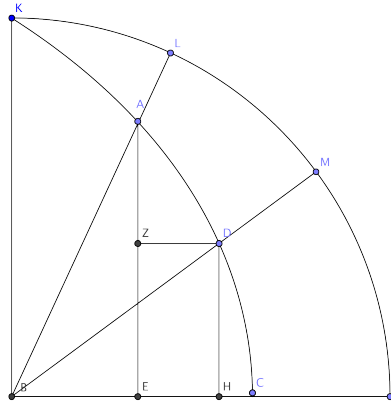

Figure 2.4.1: General angle division by the Quadratrix.

- $\widehat{KT} : \widehat{LT} = KB : AE$, $\widehat{KT} : \widehat{MT} = KB : DH$. These proportions hold, according to Pappus, because they are the "symptoma of the line" namely, the defining properties of the quadratrix mentioned in proposition 26 of Pappus book IV.
- Since $\widehat{LT} : \widehat{MT} = AE : DH$, because of the symptoms of the quadratrix, and $ZE = DH$ (by construction), we shall have: $\widehat{LT} : \widehat{MT} = AE : ZE$.
- By Euclid, *El.* V, 17, the following proportion can be obtained: $(\widehat{LT} - \widehat{MT}) : \widehat{MT} = (AE - ZE) : ZE$, namely: $\widehat{LM} : \widehat{MT} = AZ : ZE$.
- Since $AZ : ZE = a : b$, by construction, then: $\widehat{LM} : \widehat{MT} = a : b$.

Solution via the spiral

It is required to divide an angle φ , or the corresponding circular arc \widehat{AC} (fig. 2.4.1), into the ratio $a : b$. (a, b are natural numbers).

1. Construction

- Draw the radii BA and BC .
- Describe the spiral $BZDC$ inscribed in the circle ACH , with center B .

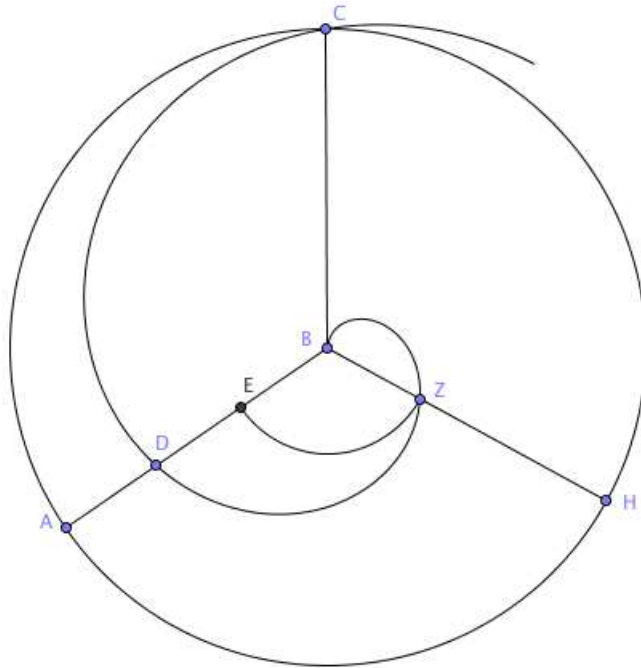

Figure 2.4.2: General angle division with a spiral.

- Trace on DB a point E , such that $DE : EB = a : b$ (this can be done in an elementary way).
- Through E draw EZ , arc of a circle with center B and radius BE , which intersects the spiral in point Z .
- Extend BZ to point H , on the circumference of the circle.
- \widehat{AH} is to \widehat{HC} as the given ratio.

2. Proof

- Calling \widehat{AHC} denotes the circle with radius AB , and center B , we have that: $BC : BD = \widehat{AHC} : \widehat{AC}$; $BC : BZ = \widehat{AHC} : \widehat{HC}$. As for the quadratrix, these proportions hold because they describe the *symptoma* of the spiral.
- $BD : BE = \widehat{AC} : \widehat{HC}$ (Euclid, V, 22).

- $DE : EB = \widehat{AH} : \widehat{HC}$.
- Therefore, $\widehat{AH} : \widehat{HC} = a : b$. (Euclid, V, 17).

2.4.2 Problems related to the general angle division

Pappus adds some problems related to the General Angle division, because they are easily solvable given the solution of the former problem. For instance, we read in proposition 36:

it is possible to cut off equal arcs from unequal circles.⁸⁸

In the subsequent proposition 37:

<Let the task be> to put together an isosceles triangle with both angles at the base possessing a given ratio to the remaining one.⁸⁹

And in proposition 38:

it is obvious that it is possible to inscribe an equilateral and equiangular polygon that has as many sides as anyone might prescribe into a circle.⁹⁰

Together with proposition 41, on the construction of incommensurable angles, these problems conclude the subgroup of propositions directly related to the General Angle Division problem.

2.5 The rectification problem

A second set of problems in Pappus' *Collection* is correlated to the rectification of the circumference, which allows us to solve the circle-squaring problem, the second central issue belonging to the third kind of geometry, according to Pappus's narration. Book IV of the *Collection* contains in fact the best documented record of an ancient technique for solving this problem, which had recourse to the quadratrix.

⁸⁸Sefrin-Weis [2010], p. 157. Pappus [1876-1878], vol. I, 287.

⁸⁹Sefrin-Weis [2010], p. 157.

⁹⁰Sefrin-Weis [2010], p. 158.

Other sources attest solutions of the rectification of the circumference that employed different curves. For instance, the philosopher and commentator Iamblichus remarks:

Archimedes effected it [the rectification of the circumference] by means of the spiral-shaped curve, Nicomedes by means of the curve known by the special name *quadratrix*, Apollonius by means of a certain curve which he himself calls "sister of the cochloid" but which is the same as Nicomedes' curve, and finally Carpus by means of a certain curve which he simply calls (the curve arising) from a double motion.⁹¹

The solutions mentioned in the above passage are not extant for us, except for Archimedes' construction, which can be derived from theorem XVIII of treatise *On Spirals*. In this work, it is proved that the subtangent to a spiral at the endpoint of its first turn is equal to the circumference of the circle, whose radius equals the generating radius of the spiral.

This construction, as well as the one using the quadratrix, will be discussed in the sequel.

2.5.1 The rectification of the circumference via quadratrix (Pappus, *Collection*, IV, proposition 27)

In this section I will present the procedure for rectifying the circumference, and thus solve the circle-squaring problem, relying on the quadratrix, as it is presented by Pappus in the *Collection*.⁹²

Let us construct a quadratrix BFM in a given quadrant BAD , as in the diagram of fig. 2.5.1. The quadratrix possesses the following property which can be successfully employed for rectifying the circumference: the point M at which this curve cuts the horizontal line AD is such that the radius AD is mean proportional between the arc of circle \widehat{BD} and the segment AM , cut by the quadratrix on AD .

In order to prove it, Pappus recurs to an indirect argument not so transparent at a first glance. Reasoning by absurd, he assumes that:

$$\widehat{BD} : AB \neq AB : AM$$

⁹¹See Heath [1981], p. 225.

⁹²The invention of the quadratrix, attributed, in the above quoted passage of Iamblichus, to Nicomedes, is dubious. For a discussion see Tannery [1883], Knorr [1986], p. 84-86.

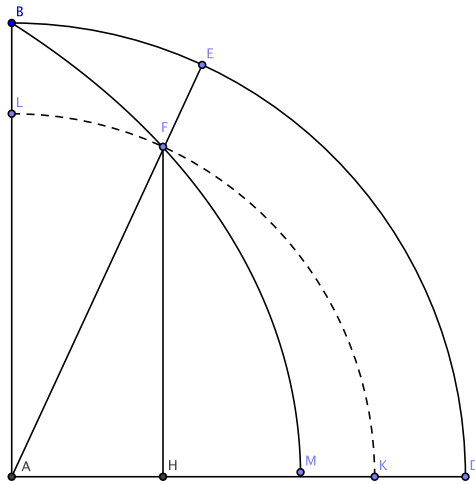

Figure 2.5.1: Rectification of the circumference by a Quadratrix.

Given this disproportion, he is able to write:

$$\widehat{BD} : AB = AB : AK,$$

where the point K is another arbitrary point of the line AD , distinct from M . It follows that K lies on one or on the other side of AD with respect to M . We can discriminate the two situations using the symbol “ $>$ ”:

- The first situation is represented by the expression: $AK > AM$;
- whereas the second by: $AK < AM$.

Assume the first case. With center in A and radius AK , trace the arc KFL , where F is the intersection point between the arc and the quadratrix. Thus, we will have:

$$\widehat{BD} : AB = AB : AK$$

Moreover, Pappus asserts that:

$$\widehat{BD} : AB = \widehat{KFL} : AK$$

as arcs on equal angles are proportional to their radii.

As a consequence:

$$AB = \widehat{KFL}$$

From the definition of the curve, we also have that $\widehat{BD} : \widehat{ED} = AB : FH$, while $\widehat{BD} : \widehat{ED} = \widehat{KFL} : \widehat{FK}$.

Since $AB = \widehat{KFL}$, it follows that $\widehat{FK} = FH$.

For Archimedes' assumption 1 in *The Sphere and the Cylinder*, $FK < \widehat{FK}$,⁹³ while FK is the hypotenuse of the right triangle FHK , therefore, $FH < FK$. As a consequence, $FH < \widehat{FK}$, which contradicts the previous conclusion that: $\widehat{FK} = FH$. Pappus can therefore discard the possibility that point K is situated between A and M .

Let us assume then the second case, and let us suppose a point K given, such that $AK < AM$ (fig. 2.5.1). Let a circular arc \widehat{LK} be described, with center A and radius AK . The reasoning following by Pappus in disproving this case is almost analogous to the previous one, with the exception that the arc \widehat{LK} cannot cut the quadratrix. Let then the perpendicular KF to AD be raised, which intersects the quadratrix in F , and let AF be joined and extended to E (lying on the circumference). We will call C the point of intersection between segment AE and the arc \widehat{LK} , and CH the perpendicular from point C to the segment AD .

By the same reasoning displayed before, Pappus can write: $\widehat{LK} = AB$. As in the previous case, the following proportions will hold, too:

$$\widehat{BED} : \widehat{ED} = \widehat{LK} : \widehat{CK} = BA : CH$$

⁹³"Of all lines that have the same extremities the straight line is the least", Heath [1897], p. 3.

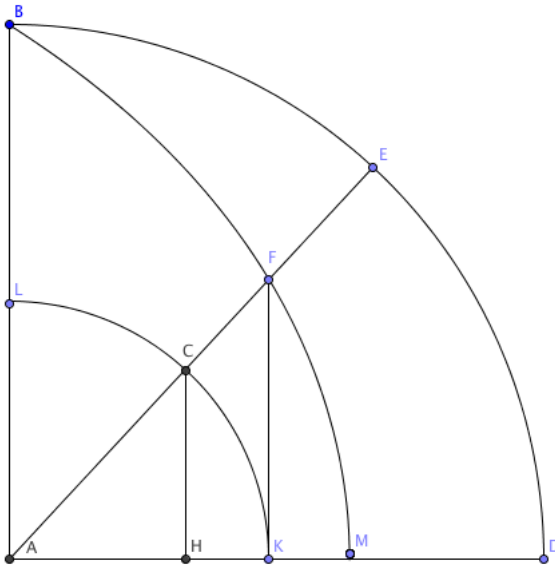

Figure 2.5.2: Rectification of the circumference by a Quadratrix.

This proportion entails: $\widehat{CK} = CH$, which is contradictory, as $\widehat{CK} > CK > CH$, by virtue of Archimedes' first assumption in the *Sphere and the Cylinder*.

Eventually, both cases lead to an absurdity, so that neither $AK > AM$ nor $AK < AM$ hold. Consequently, Pappus can conclude that $AK = AM$, and thus consider the following proportion:

$$\widehat{BD} : AD = AD : AM$$

to be proved.

Given this proportion, the problem of rectifying the arc \widehat{BD} can be easily solved too. Moreover, since the arc corresponds to a quarter of circumference, a segment equal to the whole circumference can be constructed consequently. Finally, thanks to a result given by

Archimedes in *Dimensio circuli*⁹⁴ it is easy to pass from this conclusion, which solves, properly speaking, only the problem of the rectification of the circumference of the circle, to the quadrature of the circle itself.

The rectification of the circumference can be solved through the quadratrix, by applying the construction protocol described above, if point M , foot of this curve, is given or constructed. As we know from Sporus' remarks, the very construction of M was not assured by the generation of the quadratrix curve by a couple of motion. In proposition 36, however, Pappus does not raise any problem in connection with the construction of M , arguably presupposing its existence, at least in the geometric context of this proposition, on the ground of some intuition about the nature of continuous magnitudes.⁹⁵

Conclusively, the construction exposed in Pappus' *Collection* heavily relies on our intuition of continuity, to which the geometer must make appeal in order to assume point M as given. Such a reliance on intuition raised a serious concern from the end of XVIth century, when attempts flourished to ground the existence of point M on explicit constructions. These attempts went together with the efforts made by early modern geometers to circumvent Sporus' second objection to the construction of the quadratrix: indeed, if a method to construct the foot of the quadratrix could be found, the rectification problem would be solved as well.⁹⁶

⁹⁴See this study, p. 32.

⁹⁵Incidentally, this example is chosen by W. Knorr in order to defy Zeuthen's classical interpretation on constructions as existence proofs in ancient geometry (See Zeuthen [1896], and Knorr [1986], Knorr [1983] for the criticism). Indeed, this example could be taken as a counterinstance to Zeuthen's thesis, according to which the solution of problems of construction is intended to establish the existence of the resulting configurations and of the geometric objects thereby denoted. In our case, on the contrary, the existence of point M is simply assumed, although it is clear from the context of Pappus' construction that the point is not obtained via a construction.

⁹⁶The best known case is certainly the one of Clavius, who dedicated important studies to the quadratrix (see Bos [2001], p. 159-165, Mancosu [1999], p. 75-77). The search for alternative descriptions of the curve might not respond only to a strictly mathematical concern, namely, solving the circle-squaring problem, but also to a more general, metatheoretical or broadly philosophical questioning: how is a curve to be represented for the geometer to have knowledge of it? Is motion eliminable from the generation of Pappus' curves of the third kind, or is the complex combination of motions reducible to a simpler generation? As I will show in the next chapters, this complex bundle of questions informed the context in which Descartes' *Géométrie* saw the light.

2.5.2 The converse problem: to construct a circumference equal to a given segment

In proposition 39, Pappus solves the converse problem of the rectification of a circumference, namely:

...How one finds a circle the circumference of which is equal to a given straight line...⁹⁷

The problem can be easily solved if we know how to solve the rectification of the circle; however, Pappus' protocol is instructive, as it offers a partial example of the analytic-synthetic argumentative mode, the synthesis being omitted from his account. Pappus' solution can be reconstructed as it follows.

Analysis

1. Assume that the problem has been solved: a circle a whose circumference is equal to a given segment c has been found.
2. Construct an arbitrary circle b .
3. Construct, by means of the quadratrix, a segment d equal to the circumference of b .
4. If we call r_a the radius of the first circle and r_b the radius of the second one, then the following proportion will hold: $d : c = r_b : r_a$.⁹⁸
5. Since the ratio of d to c is given, so is the ratio of r_b to r_a . Since r_b is given, therefore r_a is given.⁹⁹

⁹⁷Sefrin-Weis [2010], p. 159.

⁹⁸Using modern symbolism, one can observe that, by construction, $d = 2\pi r_b$. Moreover it is known from the starting point of our analysis that: $c = 2\pi r_a$. As a consequence, $d : c = r_b : r_a$. The same proof can be given, in a more extended form, by relying on the fifth book of the *Collection*, proposition XI (Pappus [1876-1878], I, p. 335).

⁹⁹Formulary expressions of the kind "The ratio, however, of d to c <is given.> Therefore, the ratio of the radii to each other <is given>, also" (Sefrin-Weis [2010], p. 160) are commonplace in the ancient technique of analysis. Analysis used in fact a collection of inferential patterns, codified in Euclid's *Data* in order to plot a path from the primary given geometric elements to the ones immediately constructible from them, and so on, until the geometer reached the last step of analysis. In particular, in the analysis of Pappus here reproduced, the inference from the givenness of the ratio of c to d to the givenness of the ratio of r_a to r_b relies on the results contained propositions 1 and 2 of Euclid's *Data*, together with definition 5 of the same treatise.

Synthesis (Commandinus)

Pappus omits the synthesis of the problem, which is given instead by Commandinus in his 1588 edition.¹⁰⁰ Commandinus starts by enunciating the problem:

- Let a given finite straight line c , to find a circle, whose circumference is equal to c .

Commandinus then constructs the problem according to the following protocol:

1. Construct a circle b with radius r_b , and rectify it by means of the quadratrix, so as to obtain a segment d equal to the circumference of b .
2. Construct a segment r_a such that: $r_b : r_a = d : c$.
3. Construct a circle a with radius r_a . The circumference of a equals the segment c .
4. Proof. By construction, we have that: $r_b : r_a = d : c$. The following proportion holds too: $r_a : r_b = b : a$. If we indicate the circumference of circle a with the symbol \widehat{a} , then the following proportion will ensue: $b : a = \widehat{b} : \widehat{a}$. Therefore, we will also have: $d : c = \widehat{b} : \widehat{a}$, and, permutando: $d : \widehat{b} = c : \widehat{a}$. By construction, the circumference of b equals the segment d . Therefore the circumference of a is equal to the segment c .

2.5.3 Rectification through the spiral (Archimedes, On Spiral lines, prop. XVIII)

As I have anticipated, no rectification of the circle requiring the spiral is extant in ancient sources. However, precious indications on how to solve the rectification of the circumference (and thus the quadrature of the circle) by means of the spiral can be collected from Archimedes' treatise *On Spirals*.¹⁰¹ In particular, a theorem is proved by Archimedes, establishing a property of the tangent to the spiral in the endpoint of its first turn, from which a constructive solution of the circle-squaring problem can be promptly deduced.

We read, in fact, in proposition XVIII of the mentioned treatise (I refer to figure 12 below, which reproduces with minor differences the diagram as it can be found in Heiberg's critical edition):

¹⁰⁰Commandinus [1588], 70r.

¹⁰¹Archimedes [1881], vol II, p. 3-140; Heath [1897], pp. 151-188.

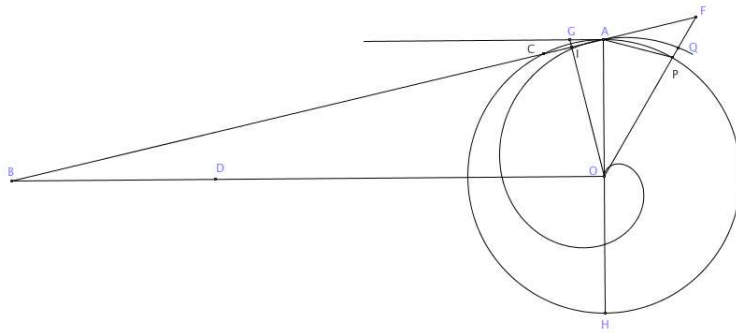

Figure 2.5.3: Rectification property of the spiral.

If OA be the initial line, A the end of the first turn of the spiral, and if the tangent to the spiral at A be drawn, the straight line OB drawn from O perpendicular to OA will meet the said tangent in some point B , and OB will be equal to the circumference of the ‘first circle’. ¹⁰²

In other terms, if the tangent to the spiral at the endpoint of its first revolution (point A in fig. 2.5.3) is extended to meet the perpendicular to the initial position of the radial generator OA of the curve, then the segment cut off this line (namely, the subtangent OB) will be equal to the length of the circumference of the circle with radius equal to the radial generator (namely \widehat{ACH}).

2. Proof (figure 2.5.3)

It is demanded to prove that the segment OB is equal to the circumference \widehat{ACH} .

Let ACH be the circle with radius OA (the generator of the spiral) and center O . Archimedes relies on theorem 16 of the same book as a lemma,¹⁰³ in order to state that the tangent to the spiral at A will cut the circle in a point C (). Moreover, since angle $O\hat{A}C$ is less than one right angle, by Euclid’s fifth postulate the tangent to the spiral

¹⁰²Heath [1897], p. 171. The theorem is contained in proposition XVIII of the treatise (Heiberg, II, 171).

¹⁰³See Heath [1897], p. 169. With respect to fig. 2.5.3 th. 16 can be thus formulated: "If BF is a tangent to the spiral at A , AF being the ‘forward’ part of BF , and if OA be joined, the angle OAF is obtuse, while the angle OAB is acute".

at point A will also cut off a segment OB on the perpendicular from O to the radius OA . Archimedes states, in proposition XVIII, that the segment OB is equal to the circumference \widehat{ACH} .

In order to prove this theorem Archimedes reasons indirectly: he assumes that either $OB > \widehat{ACH}$ or $OB < \widehat{ACH}$, and then derives a contradiction from each of these cases.¹⁰⁴

It will be useful to sketch the first part of this proof. Let us therefore assume:

$$OB > \widehat{ACH}$$

and cut off a segment OD such that: $OB > OD > \widehat{ACH}$ (fig. 2.5.3). Referring to the chord AC and the perpendicular to it OI , we will have therefore the following disproportion:

$$AO : OD > AO : OB$$

A radius OP can be traced, such that if it is extended to meet the tangent AB in F , the following proportion will result:¹⁰⁵

$$FP : PA = AO : OD$$

Since $AO = PO$, and alternating the previous proportion, we will have:

$$FP : PO = PA : OD$$

¹⁰⁴Heath [1897], p. 171.

¹⁰⁵Archimedes' proof depends on the previous proposition 7 of the treatise *On spirals*, which allows this possibility and performs the construction of the line OPF through a *neusis*. Incidentally, this is the *neusis* - construction also evoked by Pappus, in Book IV of the *Collection*, in connection with violations of the homogeneity requirement, that we have examined above. I observe in fact that Archimedes assumed the possibility of the *neusis*, but did not specify how it was to be effected (see Knorr [1986], p. 176-178, and in particular Knorr [1978]).

Since $PA < \widehat{PA}$ (on the ground of Archimedes' first assumption in *On the Sphere and the Cylinder*) and on the assumption that $OD > \widehat{ACH}$, we can deduce:

$$PA : OD < \widehat{PA} : \widehat{ACH}$$

which entails:

$$FP : PO < \widehat{PA} : \widehat{ACH}$$

Componendo the previous proportion, we obtain:

$$(FP + PO) : PO < (\widehat{PA} + \widehat{ACH}) : \widehat{ACH}$$

Since \widehat{ACH} denotes the circumference of the circle, the defining property of the spiral (namely, the arcs and the corresponding radial generators have the same ratio) yields that the right-hand ratio above equals, namely the ratio $OQ : OA$.

From this result, the following disproportion can be derived:

$$FO : PO < OQ : OA$$

From $FO : PO < OQ : OA$, and from the equality between PO and OA (both radii of the same circle), the following inequality can be also derived: $FO < OQ$. But this is impossible, because by construction point Q lies between points P and F . This terminates the *reductio ad absurdum* argument, and leads to the conclusion that segment OB is not greater than \widehat{ACH} .

Subsequently, Archimedes treats the other branch of the alternative, by supposing: $OB < \widehat{ACH}$. Although the argumentative steps differ with respect to the previous case, the general procedure follows a similar *reductio* strategy. I will thus refer to the discussion in

Dijksterhuis and Knorr [1987] for a precise reconstruction,¹⁰⁶ and skip to the conclusion of Archimedes' argument: since OB is neither greater nor smaller than \widehat{ACH} , it must be equal to the circumference.

As I have observed, although no rectification of the circle requiring the spiral is extant in ancient sources, it is not difficult to sketch, from the above theorem, a construction protocol in the following manner:¹⁰⁷

1. Construction

- Let a spiral be constructed, with center O , and radial generator OA .
- Let a circle ACH with center O and radius OA be constructed. Let us call \widehat{ACH} its circumference.
- Let a straight line OE be cut perpendicularly to OA .
- Let the tangent AC to the spiral in point A be traced, and let B be the intersection point between the tangent and the line OE .
- By virtue of theorem 18 of Archimedes' *On Spirals*, segment OB is equal to the circumference \widehat{ACH} . Since the ratio between the circumference of a circle and its diameter is constant, the rectification of the circle ACH allows us to deduce the rectification of any given circle.

Since there are no extant documents containing a solution of the rectification problems by mean of the spiral, we can only conjecture whether such a solution was or would have been accepted as a correct and sound construction of the problem. It is arguable that doubts against the soundness or the feasibility of the above solution were raised, already in antiquity, in connection with the construction of the spiral. The description of this curve required, in fact, to tackle the difficult task of coordinatizing a radial and a circular uniform motion.

¹⁰⁶See Heath [1897], p. 172; Dijksterhuis and Knorr [1987], p. 270.

¹⁰⁷A similar protocol is described, for instance, in F. Viète's *Variorum de rebus mathematicis* (Viète [1593], p. 24).

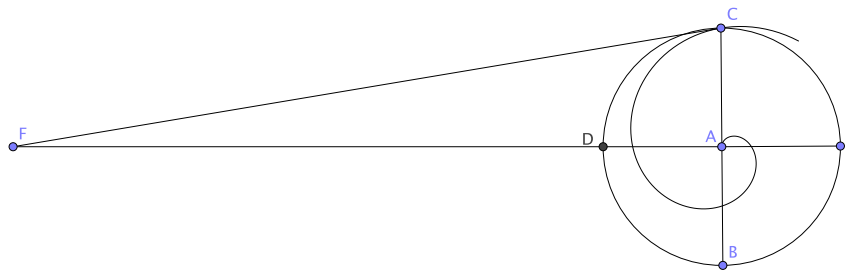

Figure 2.5.4: Rectification property of the spiral.

A second hindrance to the acceptability of this construction could have been represented by the auxiliary construction of the tangent to this curve. Indeed, even if the spiral was the object of intense study since the late middle ages, thanks to the circulation of the first Latin version of Archimedes' works and the connection between the construction of the tangent and the rectification of the circle was noted and discussed by commentators, no one, to my knowledge, had conceded the exact constructibility of the tangent.¹⁰⁸

The riddle about this construction received a definite clarification well into XVIIth century, with the emergence of infinitesimal calculus, and when the tangent to a curve passing from one of its points was finally conceived as the limit of the secants to this curve.

2.6 On the quadrature of the circle

In the structure of the fourth Book of the *Collection*, the problems of rectifying the circumference and squaring the circle are evoked after plane and solid ones, and together with the general angular division, they are instances of 'linear' problems. However, it should be noted that it is not required, in order to solve the problem of the General Angle Division, to construct the (problematic) intersection point between the quadratrix and the axis, but only to assume the quadratrix (or the spiral) as given. On the contrary, the solution of the rectification of the circumference by means of the quadratrix involves the supplementary problem of exhibiting its terminal point.

In the previous section, we have also inquired whether the solution of the rectification problem through the spiral, which, unlike the quadratrix, is not touched by Sporus' objection on the non-constructibility of its points, would have provided a fully-fledged solution of the rectification of the circle. We listed few reasons for doubting that a construction employing the spiral could be accepted by ancient mathematicians as a satisfactory solution to the rectification of the circumference.

The issue of the quadrature of the circle surfaces on several occasions in commentaries to the aristotelian corpus from late antiquity, posterior to Pappus. Although the context is that of commentaries to philosophical works, the commentators themselves did not lack

¹⁰⁸See Clagett [1964-1984], vol. 2 and vol. 5 in particular. Useful information can be found, for instance, in Hofmann [1954]. Hoffman's article also contains the exposition of an early-modern attempt to provide an approximate method for the tracing of the tangent of the spiral, due to Viète.

good mathematical credentials, and the way in which they engaged with the mathematical examples summoned by Aristotle can cast a light on the contemporary knowledge of these themes.

Consistently with what remarked in chapter 1 of this work, we can infer from the testimony of commentators that the circle-squaring problem (and therefore the problem of rectifying the circumference too) was still regarded as an open problem in late antiquity.

A remark¹⁰⁹ at point is, for instance, the one made by Ammonius (ca. 435/445–517/526), a commentator of Aristotle and pupil of Proclus:¹¹⁰

Having erected a square equal to a rectilinear figure, geometers also sought, if possible, to find a square equal to a given circle. Many geometers - included the greatest ones - looked for it, but did not find it. Only the divine Archimedes discovered anything at all close, but so far the exact solution has not been discovered. Indeed it may be impossible. And this is, in fact, why Aristotle says: 'if indeed it is something to be known' [It is perhaps because he produced a straight line not dissimilar to the circumference <that he was in doubt> whether it is or is not something to be known.] He therefore says that if indeed the squaring of the circle is something to be known although the knowledge of it does not yet exist, it follows from this that what is known is prior to knowledge.¹¹¹

Ammonius is commenting, in the passage above, upon a remark on the quadrature of the circle made by Aristotle in the course of a discussion, which occurs in chapter seven of the *Categories*, about knowledge as belonging to the category of 'relative'. In the course of this discussion, Aristotle chose the example of the circle-squaring problem in order to illustrate the relation between knowledge and knowable, and in particular the following thesis: "for if there is not a knowable there is no knowledge - there will no longer be anything for knowledge to be of - but if there is not knowledge there is nothing to prevent there being a knowable".¹¹² The squaring of the circle was indeed a case at point of something that may knowable, although not yet known.

¹⁰⁹I shall follow, in the subsequent lines, the account offered by Knorr (Knorr [1986], p. 361-381).

¹¹⁰Although primarily known for his commentary to Aristotle, Ammonius was a distinguished geometer himself (see David [2012]).

¹¹¹Ammonius [1992], 75, 10. See also Knorr [1986], p. 362.

¹¹²Aristotle [1963], 7b 30-35.

The example of the quadrature of the circle offered to Ammonius the occasion to comment upon the current status of this geometric problem. Ammonius, who probably had some knowledge in mathematics and must therefore be considered reliable, conceded that the question about the solvability of the circle-squaring problem had not been assessed yet. Analogous opinions about the solvability of the circle-squaring problem echo also among contemporary and later commentators too.¹¹³

Let us recall, for instance, Marinus' commentary to Euclid's *Data*, a text written in the fifth century of our era, in which the quadrature of the circle was even representative of a category of problems, called '*aporon*'. As Marinus wrote:

That which we are now able to construct - i.e., to bring to our thought - is *porimon* (...) The opposite is *aporon*. For example, squaring a circle, for this is not yet in our power, even if it can be attained and falls under some science, for the scientific knowledge of it has not yet been grasped.¹¹⁴

In other words, the class of problems labelled by the term '*aporon*' groups all those problems "whose investigation is undecided (*adiakritos*)", under which Marinus ranged the quadrature of the circle. By the term undecided, namely '*adiakritos*', Marinus meant, in particular, arguably problems in want of a satisfactory solution, and for which it is unknown whether a satisfactory solution did actually exist.¹¹⁵

But what might have been a 'satisfactory' solution, in the context of Marinus' considerations? We do not precisely know of constraints on the acceptability of curves and solutions in force within Greek mathematics, although there is evidence that a distinction between acceptable and non acceptable constructions was contemplated, at least among geometers and commentators from the late antiquity. In his commentary on Aristotle's *Categories*, for instance, Simplicius¹¹⁶ referred to the circle-squaring problem

¹¹³See again the survey contained in Knorr [1986], p. 362. We read, for instance, in Simplicius' *Commentary* to the seventh Book of the *Physics* (1083, 1): "[In Aristotle's days], it was still being investigated whether it is possible for a straight line to be equal to a curve, or rather it had been given upon. And hence the squaring of the circle had not yet been discovered either, and, even if it seems to have been discovered now, nevertheless it is accompanied by certain disputed hypothesis. The reason why the squaring of the circle, though not yet discovered, is still being investigated, as well as [the question] whether a straight line is equal to a curved one, is that it has also not been discovered that these things are impossible, as for instance [it has that] the diagonal is incommensurable with the side. This is why the latter is not still being investigated".

¹¹⁴In Euclid [2003], p. 244-245.

¹¹⁵Euclid [2003], p. 245.

¹¹⁶Simplicius was probably born towards the end of V century A. D, and was himself a disciple of Ammonius. As for his teacher, we can find sparse remarks about the circle-squaring problem in Simplicius'

and remarked that geometers had come up, by the time he was writing, only with 'instrumental' ('*organike*') constructions or discoveries instead of providing 'demonstrative' ('*apodeiktike*') ones.

Anyway, the distinction at stake here between 'organical' and 'demonstrative' constructions seems to concern a distinction into geometrically legitimate and illegitimate methods in problem solving. I remark that the term employed by Simplicius is '*organikos*' ('*ὀργανικῶς*'), which refers, as we have seen, to the use of instruments for the generation of curves. Simplicius does not employ the term '*mekanikos*' ('*μηχανικῶς*'), which was used by Sporus in order to qualify the generation of the quadratrix, instead. W. Knorr advances the conjecture that Simplicius might be conflating both terms, treating 'instrumental methods' as a synonym with 'mechanical methods'. An 'organic' construction of the quadrature of the circle would be, therefore, a construction of the problem which makes appeal to curves of the third, linear class, like the quadratrix, or to approximate methods, as it occurred with the classical techniques consisting in approximating the surface of the circle by sequences of inscribed and circumscribed polygons.¹¹⁷

If we confine to the solution of the circle-squaring problem by means of intersection of curves, Pappus' *Collection* represented, among ancient source, the most complete survey into the problem. In Book IV of the *Collection*, in particular, Pappus had offered an insight into a possible way to solve the problem, together with its formal justification. A fully-fledged construction of the quadrature of the circle according to the protocol devised in the *Collection* depended on the condition of defining the quadratrix as a geometrical curve, so as to be able to use it as a reliable means of construction. This implied, moreover, that a method for generating the quadratrix had to be described, such that the foot of this curve could be constructed too.

The positions I have surveyed allow us to conclude that, although it was not excluded by late mathematicians and commentators that the problem of the quadrature of the circle might be impossible, nevertheless it was still considered as a rational, and even plausible endeavor to investigate its construction, possibly by more geometrical method

commentaries to Aristotle. In spite of their non-technical character, these remarks are valuable, as Knorr observes, since: "the commentators often avail themselves of the authorities from the technical literature as well as from the historical and philosophical writings in geometry. Thus, one might expect that they would reflect whatever conclusions had been drawn concerning the status of the circle quadrature among the ancient geometers." (Knorr [1986], p. 361). See also Knorr [1986], p. 364.

¹¹⁷This approximation is described by Archimedes in his *A Measurement of the Circle* (Archimedes [1881], vol. I, p. 257).

than ‘linear’ curves, or curves of the third kind. Conclusively, in spite of its indirect character, the evidence offered by late antiquity commentators represents an important source of information on the status of the circle-squaring problem during that period: this was an ‘open problem’, because it had received thus far no acceptable and fully satisfactory solution. Even if the solutions to the circle-squaring problem which made appeal to ‘linear’ curves were known to mathematicians from late antiquity, they probably have failed to meet proper standards for geometricity in force within those historical settings.

On the aftermath of the publication of the latin translation of the *Collection* (1588), due to Commandinus, mathematicians saw in perfectly clear terms the question at stake: the study of alternative descriptions of the quadratrix with respect to the ones given by Pappus might offer a construction of the foot of this curve, and thus provide a solution for the sought-for circle-squaring problem. Some of these attempts, as well as the ultimate criticism advanced by Descartes on this subject will be examined in the next chapters.

Chapter 3

The geometry of René Descartes

3.0.1 Descartes' geometry and its methodological presuppositions

XVIIth century was a period of profound changes in the image and content of geometry. With the exception of the theory of conic sections, that had reached a high level of sophistication thanks to the work of Apollonius, in particular, ancient Greeks lacked a systematic treatment of more complex curves, although they studied and employed in problem-solving some interesting special curves (I have discussed some of them in the previous chapter). On the contrary, from the 1630s the field of known geometric curves recorded, over a short period of time, a considerable growth with respect to the curves accessible to ancient geometers. In Bos [1981], for instance, three directions of research are individuated through which new curves could enter the mathematical discourse. Curves could be introduced as given objects of study: this is the case of the cycloid, the curve described by the rim of a rolling circle, whose properties as its area, the areas and centres of gravity of its segments and the contents and centres of gravity of solids arising by rotation of its segments were studied in response to a famous challenge proposed by Pascal in 1658 (*cf.* Bos [1981], p. 295-296). Otherwise, curves could be introduced as means for solving problems (one can think, for instance, of the cartesian parabola constructed by Descartes in order to construct the roots of equations in fifth and sixth degree, and illustrated below, at p. 3.2.1). Finally, curves arose as solutions to problems (for example the '*linea proportionum*', a curve nowadays considered as a primitive representation of an exponential function, which arose in connection with the problem of compound interest.¹

¹See Bos [2001], p. 246.

However, this undeniable enrichment in the domain of curves, and consequently in the domain of problem-solving methods, should not adumbrate the fact that classical geometry exerted a pervasive influence on the early-modern period. Not only ancient sources still dictated, until well into XVIIth century, the agenda of problems to be solved and offered a basic repertoire of techniques to be used in this activity, but Greek mathematical texts, which survived and circulated among XVIth and XVIIth century practitioners (it is the case, as I have recalled in the previous chapter, of Pappus' *Mathematical Collection*), also contained important predicaments on the way of framing the global activity of solving problems and organizing the body of mathematical knowledge.

It should be noted that the availability of diverse techniques for problem-solving hardly entailed their overall acceptability in geometry. Early modern geometers were often called to decide, through a tacit or explicit recourse to extramathematical deliberations, which curves and methods could be legitimately used in order to solve a problem at hand, and which ones, on the contrary, were not to be used for the same goal. Thus, several early modern geometers seriously considered the following cluster of questions: 'how curves themselves were to be constructed? Which construction methods satisfied the requisites of exactness that one wishes to attribute to any geometric procedure, and which ones, on the contrary, lacked the exactness of proper geometric thinking?' Answers obviously varied, depending on available technical knowledge, but also on the ideal of exactness that the single geometer might embrace.²

It is admitted that a turning point in this history is represented by Descartes' work in geometry, culminated with the publication of *La Géométrie*, in its french first edition (1637), and successfully in two latin editions, from 1649 and 1659-61.³ Descartes' geom-

²For a book-length discussion of these questions, at least during the period between 1590 and 1650, I refer to the ground-breaking Bos [2001]. Bos gives a general characterization of 'exactness', as the quality of mathematical procedures that, in the opinion of some mathematicians, makes them acceptable as leading to genuine and precise mathematical knowledge. An important clarification on the matter of exactness is offered in the contributions by Panza (see Panza [2011]). Concerning the definition of exactness, Panza explains: "The exactness concern for classical geometry was not a matter of accuracy. Accuracy was certainly a requirement for practical or applied geometry, but the exactness requirement concerned pure geometry, and was quite different: whereas, for the purposes of practical geometry, it was required to perform some (material) procedures with a sufficient degree of precision, in pure geometry it was required to argue in some licensed ways. This is what the exactness concern was about" (Panza [2011], p. 46).

³The second latin edition of Descartes' geometry, published in two volumes in 1659 and 1661, respectively, included some papers from Van Schooten's students and colleagues. These papers contained results of their research on Descartes' geometry. For instance, Jan de Witt (1625-1672) treated conic sections; Jan Hudde (1628-1704) studied in one article the factorization of polynomial equations, and in a second paper, he simplified Descartes' method of normals. Finally, Hendrick Van Heuraet (1634-1660?)

etry exerted a considerable influence over the mathematicians of XVIIIth century, as it framed a new and general method for problem-solving.

A survey of Descartes' method will be the starting point of my inquiry too. In particular, I will probe into the guidelines, or norms, governing the search for solutions to geometrical problems and the criteria for the acceptability of solving-methods deployed by Descartes in his *Géométrie*.

A methodological point I am going to unravel - in chapter 5 of this study - concerns the demarcation between legitimate and illegitimate solving methods, deployed in the second book of Descartes' treatise. Since Descartes relied on the solution of geometric problems by intersection of curves, for him the criteria in order to demarcate the collection of acceptable methods ought to depend on a distinction between acceptable, or "geometrical" curves, and "mechanical" ones, the latter being excluded from the scope of geometry.

In chapter 4, I will examine a second aspect of Descartes' programme instead, namely his classification of curves and the internal constraints imposed on the solvability of problems. The legacy of ancient geometry was significant with respect to this issue. For instance, the "metatheoretical" passage on the classification of problems, in Book IV of Pappus' *Collection*, exerted a palpable influence over the choice of the most adequate solution to a given problem, and it shaped, in this way, Descartes' problem solving strategy.⁴

contributed some material to *Geometria*, addressing the problem of the rectification of curves. In his Phd dissertation, S. Maronne interestingly argues that the *Géométrie* of 1637 is but one among four 'Geometries'. A 'second geometry' consists of the collection of critiques to Descartes' *Géométrie* and of his own replies, mainly consigned to correspondence, A 'third' and a 'fourth geometry' are represented by the two first latin editions mentioned in the main text: the first one from 1649, and the second one from 1659-61. This corpus is certainly rich and varied, and it offers precious evidence of the way in which the key questions and problems brought to the fore by Descartes *Géométrie* of 1637 evolved throughout a period of about thirty years. I observe, nevertheless, that the issues I will discuss in this and the following chapters, namely the demarcation between acceptable and unacceptable curves, and the constraints on the acceptability of curves as legitimate solutions to given geometric problems, were hardly ever discussed, at least until 1667-1668, and when it happened, they were by no means object of criticism.

⁴In Commandinus' translation, Pappus' "homogeneity requirement" sounded even more peremptory than the original, and assumed moralistic tones: "Videtur autem quodammodo peccatum non parum esse apud Geometras, cum problema plano per conica, vel linearia ab aliquo invenitur, et ut summatum (summatim?) dicam, cum ex improprio solvitur genere . . ." (Commandinus [1588], fol. 61r.): "It seems a somehow non small sin, among geometers, when someone solves a problem of plane kind by means of conics, or linear curves, and, to speak generally, when it is solved by a non-kindred kind (*improprio genere*)".

Descartes reinterpreted this precept in the light of the representation of problems and curves via algebraic equations, and incorporated it into his problem-solving practice, to the point of considering any of its violation an error in geometry ("une faute", as written in Descartes [1897-1913], vol. 6, p. 443). In fact, as it is clearly stated in the third Book of *La Géométrie*, Descartes required a solution to a mathematical problem to be not only logically correct and obtained by the intersection of acceptable curves, but also be as simple as possible. Algebra will reveal a fundamental tool in order to measure simplicity, and therefore to assess the nature of a problem by excluding too simple (and therefore impossible) solutions, and too complex ones.

As I will argue, Pappus' homogeneity requirement, reinterpreted by Descartes in the light of algebra, exerted a long-range influence on mathematical practice throughout XVII century. This requirement was not straightforward though, and gave rise to broad disagreement among early-modern geometers.⁵

My examination will take into account what I deem to be the original tension, lying at the basis of this disagreement, between two different constraints on problem-solving set and contrasted by Descartes, that I will call: "dimensional simplicity" and "easiness". The preference for the former, manifested by the author of *La Géométrie*, is counterintuitive under several aspects and was thus perceived by many readers of this work. My goal will be to motivate Descartes' choice for dimensional simplicity in the light of the ancient classification of problems and curves.

3.0.2 Descartes' early methodology of problem solving

Concerns with the proper methodology for problem-solving and with the constraints on the acceptability of curves accompanied Descartes' reflection on mathematics since the earliest sketches of the program he would later develop in 1637.

One of the first broad considerations is committed to a letter from 26th march 1619 addressed by the young Descartes to one of his closest fellows at the time, Isaac Beckmann.⁶

⁵Instances of criticism to the cartesian view on what should count as the proper solution of a problem have been analyzed in Bos [1984], especially p. 358ff.

⁶On the Dutch *savant* Isaac Beeckman, see Sasaki [2003], p. 95-103. The meeting between Descartes and Beeckman occurred in Autumn 1618, and it is worth noting in which terms Descartes recalled to Beeckman the role of the latter on his own scientific maturing: "You are truly the only one who awoke [me] from sloth, recalled erudition which had almost passed away from memory, and bettered my mind which was drifting away from serious occupations" (translation in Sasaki [2003], p. 95).

In this letter, Descartes outlined his mathematical aspirations, whose highest goal consisted in the foundations of a "new science" capable of determining the most adequate means to solve any given geometric problem, such that no problem would finally remain unsolved. Since this programme lay the groundwork for the future inquiries developed in *La Géométrie*, I will reproduce Descartes' account of it in its entirety:

Et certe, ut tibi nude aperiam quod moliar, non Lullij *Artem brevem*, sed scientiam penitus novam tradere cupio, quâ generaliter solvi possint quaestiones omnes, quae in quodlibet genere quantitatis, tam continuae quam discretæ, possunt proponi. Sed unaquæque iuxtam suam naturam: ut enim in Arithmeticâ quaedam quaestiones numeris rationalibus absolvuntur, aliae tantum numeris surdis, aliae denique imaginari quidem possunt, sed non solvi: ita me demonstraturum spero, in quantitate continuâ, quaedam problemata absolvi posse cum solis lineis rectis vel circularibus; alia solvi non posse, nisi cum alijs lineis curvis, sed quae ex unico motu oriuntur, ideoque per novos circinos duci possunt, quos non minus certos existimo & geometricos, quam communis quo ducuntur circuli; alia denique solvi non posse, nisi per lineas curvas ex diversis motibus sibi invicem non subordinatis generatas, quae certe imaginariae tantum sunt: talis est linea quadratrix, satis vulgata. Et nihil imaginari posse existimo, quod saltem per tales lineas solvi non possit; sed spero fore ut demonstrarem quales quaestiones solvi queant hoc vel illo modo et non altero: adeo ut pene nihil in geometria supersit inveniendum; Infinitum quidem opus est, nec unius. Incredibile quam ambitiosum; sed nescio quid luminis per obscurum hujus scientiae chaos aspexi, cujus auxilio densissimas quasque tenerbas discuti posse existimo.⁷

⁷Descartes [1897-1913], vol. 10, pages 154-155: "And to tell you quite openly what I intend to undertake, I do not want to propound a Short Art as that of Lullius, but a completely new science by which all questions in general may be solved that can be proposed about any kind of quantity, continuous as well as discrete. But each according to its own nature. In arithmetic, for instance, some questions can be solved by rational numbers, some by surd numbers only, and others can be imagined but not solved. For continuous quantity I hope to prove that, similarly, certain problems can be solved by using only straight or curved lines, that some problems require other curves for their solution, but still curves which arise from one single motion and which therefore can be traced by the new compasses, which I consider to be no less certain and geometrical than the usual compasses by which circles are traced; and, finally, that other problems can only be solved by curved lines generated by separate motions not subordinate to one another; certainly such curves are imaginary only; the well known quadratrix is of that kind. And in my opinion it is impossible to imagine anything that cannot at least be solved by such lines; but in due time I hope to prove which questions can or cannot be solved in these several ways: so that hardly anything would remain to be found in geometry" (English translation in Bos [2001], p. 232).

The ambitious program presented in this letter concerns continuous and discrete magnitudes, whose paradigmatic sciences are, respectively, geometry and arithmetic. Arithmetic and geometric problems are considered in parallel and classified according to tripartite distinctions. In particular, these disciplines mirror each other, but do not mix: it seems that Descartes excluded, by 1619, the use of arithmetic in geometric problem-solving.

Let us consider more closely the organization of geometry as it shines through Descartes' letter to Beeckman. Geometric problems are classified on the ground of the curves used to solve them. Analogously to what will be done almost twenty years later in *La Géométrie*, curves are distinguished according to the motions intervening in their generation (and, ultimately, according to the instruments employed for their construction): a major divide is made between curves obtained through a single motion (generated by the ordinary compass and by other instruments, called in the letter "new compasses") and curves obtained through several non-subordinate motions. These latter curves are called "imaginary", and among them Descartes mentions the quadratrix.

It cannot be assessed with precision whether by 1619 Descartes had read about the quadratrix in Pappus' latin translation. Another possible source for Descartes' knowledge might have been Clavius' *Geometria practica*, in which the curve is studied (see, Clavius [1604], book VII, p. 320-327), since we know that Beeckman possessed a copy of it, and references to this treatise are extant in his diaries.⁸

Nor can it be assessed with certainty whether Descartes was familiar at all, in 1619, with Pappus' classification of problems and curves. There are, at any rate, evident analogies between Descartes' classification exposed in the letter to Beeckman and the one proposed by Pappus: both admit a class of problems solvable by the intersection of straight lines and circles and a class of problems solvable by lines generated by separate motions, like the quadratrix.

Perhaps the aspect in which Descartes moves away the greatest from the traditional classification of problems based on their curve-solutions concerns the emphasis put on the instrumental generation of curves, evoked above and in other locus of the same letter, like the following:

⁸Sasaki [2003], p. 95-96.

Quatuor enim a tam brevi tempore insignes et plane novas demonstrationes adveni, meorum circinorum adjumento. Prima est celeberrima de dividendo angulo in aequales partes quotlibet. Tres aliae pertinent ad aequationes cubicas, quarum primum genus est inter numerum absolutum, radices et cubos, alterum inter numerum absolutum, quadrata et cubos, tertium denique inter numerum absolutum, radices, quadrata et cubos.⁹

Descartes claimed that he could use compasses ("*meorum circinorum*") in the demonstration of four problems: the first was the classical problem of sectioning an arbitrary angle in equal parts, the latter three problems were algebraic, and related to the construction of three general classes of cubic equations (in modern notation, these are equations of the form: $x^3 = \pm ax^2 \pm c$, $x^3 = \pm bx^2 \pm c$, $x^3 = \pm ax^2 \pm bx \pm c$).¹⁰

These compasses are probably the same instruments discussed in some of Descartes's unpublished notes from 1619-21, known as *Cogitationes Privatae*.¹¹ We find in this manuscript, in fact, the description of a device for solving the problem of sectioning an angle into three and more equal parts (Descartes calls it: "circinus ad angulum in quotlibet partes dividendum", i.e.: "compass to divide an angle into however many equal parts"), and two other instruments applied in the solution of certain cubic equations.

The compass to divide an angle into three equal parts is described by Descartes as follows (Descartes [1897-1913], vol. 10, p. 240). We consider a configuration formed by four segments or rulers AB , AC , AU and AT , such that while the first is kept fixed the other three (namely AC , AU and AT) rotate around point A . On these segments, four points

⁹Descartes [1897-1913], vol. 10, p. 154-155: "In such a small time, in fact, I have found four notable and fully new demonstrations with the help of my compasses. The first is the very famous problem of dividing an angle into any number of equal parts. The other three pertain to cubic equations: of which the first kind between an absolute number, roots and cubes; the second between an absolute number, squares and cubes; the third, finally, between an absolute number, roots, squares and cubes" (english translation in Sasaki [2003], p. 100).

¹⁰See Schuster [1980].

¹¹This is a manuscript presumably written by Descartes in the years 1619-21 which collected the results of his broad scientific activity during the time (*cf.* Descartes [1897-1913], vol 10, p. 234-241; and particularly: Descartes [1897-1913], vol. 10, p. 234-35, p. 238-40). This work came down to us through a somewhat tortuous route. Indeed it was perused and copied by Leibniz in 1676. Leibniz's annotated copy was deposited at Hannover Library, and later published by Fouché de Careil in the first volume of the *Oeuvres inédites de M. Descartes*. Unfortunately, this edition contained notable errors, but remains the only available source of Descartes' *Cogitationes*, since both the original manuscript and Leibniz's copy went lost (the latter, in fact, disappeared after Fouché de Careil could peruse it). Finally, thanks to endeavours of Gustav Eneström, Henri Vogt, and Henri Adam Fouché de Careil's version was thoroughly amended, and published in vol. 10 of Descartes' *Oeuvres*.

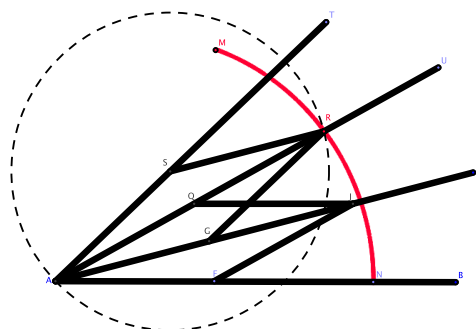

Figure 3.0.1: Trisector compass.

are subsequently marked, such that $AF = AG = AQ = AS$. At points F and Q two segments of equal length (and equal to AF) are thus constructed, joining in a common extremity at J .

The same construction is repeated, so as to obtain two other congruent segments SR and GR , connected at point R on AU (figure 3.0.2). In this way, when the segment AC pivots around A , the trajectory of point R traces a curve, by whose means a given angle, on which the compass so designed is applied, can be trisected.¹²

Descartes remarks that one could dispose of the problem of dividing an angle into 4, 5, 6... and n sections, provided more and more intermediate rulers are added to the original configuration, and corresponding sectrix curves will be traced, corresponding to each instance of the problem of dividing an angle into n equal parts.¹³

It is important to remark that this dispositive does not solve the problem of the general section of an angle, that is, all angular divisions, by tracing *one* curve only. The compass devised by Descartes, in other words, traces infinitely many curves, each apt for the

¹²Descartes [1897-1913], vol. 10, p. 240-241. The full solution is reconstructed in Bos [2001], p. 239. Let us consider the problem of trisecting a given angle $TAB = \theta$. In order to trisect it, the compass must be positioned so that one of its arms coincide with AB (as in the figure), and point R traces the curve NRM (marked in red in the figure), until the trisector is opened with amplitude θ . It is then sufficient to mark off a segment $AS = a$ on AT , and with center in S , trace a circle with radius equal to a . Named R the intersection point between the curve NRM and the circle, the angle TAR is one third of the angle TAB . The proof is immediate from the construction of the segment.

¹³Descartes [1897-1913], vol. 10, p. 241.

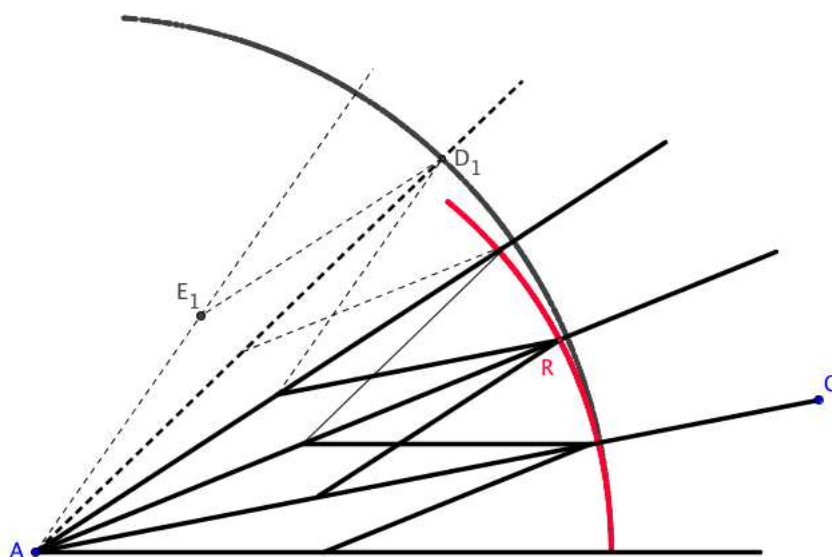

Figure 3.0.2: Generalization of a trisector compass.

solution of a particular instance of the multisection of the angle (therefore, this instrument will trace a trisectrix, a quadrisectrix, . . . an n -sectrix provided an adequate number of rulers is added). In figure 3.0.2, for instance, the compass has been suitably extended in order to perform a division of an angle into five equal parts through the curve traced by the moving point D_1 . As the figure shows, the curve so obtained sensibly differs from the curve traced by the moving point R .

The instruments mentioned in the *Cogitationes* for the solution of cubic equations were adaptations of a more general compass, perfunctorily mentioned in the *Cogitationes* as "mesolabe compass" (*circinus mesolabi*). Even if the description of this compass is unclear from the *Cogitationes*, there is a general agreement among commentators¹⁴ in considering the mesolabe compass as an early exemplification of an instrument later described in *La Géométrie* in order to solve the problem of inserting an arbitrary number of mean proportionals between two given segments (the instrument appear, without a name, in: Descartes [1897-1913], vol. 6, p. 391, p. p. 443).¹⁵

¹⁴See for instance Sasaki [2003], pp. 112ff.; Bos [2001], p. 239ff.; Schuster [1980] *et alii*. I will notice that this similarity was already indicated by Leibniz, in his marginal notes to the *Cogitationes*, at least according to Fouché de Careil's edition (Descartes [1859], p. 38, 41).

¹⁵As it is convincingly argued by Sasaki (Sasaki [2003], p. 120-121), Descartes might have been inspired by ancient examples in devising his mesolabe compass. Because of the similarity of structure (see

As suggested by Bos (Bos [2001] p. 243-244) the universality to which Descartes aspired by the use of both his instruments was legitimated by the configuration of geometric problems at the turning of XVIth century. Indeed, a part from the problems solvable within Euclid's geometry, solid problems, like the insertion of two mean proportions and the trisection of the angle were certainly known and discussed, especially after the publication of Commandinus' translation of Pappus. Among higher problems than the solid, the only known problems concerned the construction of regular polygons and the quadrature of the circle.

By supplementing instruments in order to solve solid problems, together with the problem of dividing the angle into an arbitrary number of equal parts (and therefore to solve the construction of any regular polygon too), and by adding to these instruments an imaginary curve like the quadratrix (Descartes had not excluded it from geometry, as he would do in the subsequent years), Descartes could reasonably admit that: "it is impossible to imagine anything that cannot at least be solved by such lines". In this way, he also deemed to have provided with his programme the guidelines in order to achieve the "infinite task" (*Infinitem Opus*) consisting in solving "any problem, concerning either discrete or continuous quantities, according to its own nature, without leaving unsolvable questions".

Descartes' challenge responds to another well-known passage from Viète's *In Artem Analyticam Isagoge*, in which the author praises his new analytic technique by boasting its capacity to solve the "problem of all problems, which is TO LEAVE NO PROBLEM UNSOLVED".

Descartes [1897-1913], vol. 6, p. 391, and below) Descartes might have studied the design of the mesolabe from the extant passage of Pappus' book III, or from Eutocius' *Commentary* (proving, in the first case, that he could know of Pappus' *Collection* already at the beginning of the 20s). Another possibility is that Descartes had knowledge of the ancient Mesolabe through early modern work in which it appeared, for instance: J. J. Scaliger, *Mesolabium* (Leiden, 1594); Viète, *Variorum de rebus Mathematicis Responsorum Liber VIII* (Tours, 1593); Idem, *Pseudo-Mesolabum* (Paris, 1595). A third plausible, early modern antecedent of Descartes' Mesolabe might be an instrument conceived by Galileo and illustrated in the following manual, published in 1606: *Le operazioni del compasso geometrico e militare*. Galileo's "geometric and militar compass" is a graduated instrument devised for the purpose of executing geometric operations and physical measurements without the recourse to numerical computations (for a survey of the various purposes of Galileo's compass, see Righini [1974], and Sasaki [2003], p. 103-105). The context in which Galileo's compass is studied is that of practical geometry, ballistic, land surveying and astronomy, hence an utterly different context than the one of Descartes' project in geometry. Nevertheless, we can detect a structural similarity between Descartes' mesolabe or proportions compass and Galileo compass: the principle on which both instruments are based is the similarity between triangles popping up in the configuration of the compass (Righini [1974], p. 207).

These ideas may not have come to Descartes directly from Viète.¹⁶ In fact, ambitious declarations like the ones of Viète were not rare among XVIIth century mathematicians, and could even be seen as a consequence of the widespread optimistic turn occurred in connection with the rise of algebraic methods in geometry, which has been called "mathematical utopianism".¹⁷

We can define "mathematical utopianism" as: "... the doctrine that the whole of mathematics can be developed simply, straightforwardly, and seamlessly from a few easily grasped general precepts." I will quote only two outstanding examples of this intellectual posture. In his *An Idea of Mathematics*, for instance, John Pell set out to show:

... how manie Mathematician that will take the pains, may prepare himself, so, as that hee may, though hee bee utterly destitute of Books or Instruments, resolv anie Mathematical Probleme as exactly as if hee had a complete Librarie by him.¹⁸

Later mathematicians were also imbued by similar utopian visions. A well-studied case at point is Leibniz, for instance, who showed this attitude from his early deliberations. Hence, We read in a manuscript of 1673:

I dare say that this has been discovered by me, and that I have opened the sources of the archimedean geometry which, if one follow them, can perform what is boasted by apollonian geometry: to solve a problem, or to show its unsolvability.¹⁹

These considerations must be referred to the specific mathematical context represented by problems of quadratures in Leibniz's mathematical practice. However, they seem inspired more by a general philosophical attitude than by concrete technical achievements.

¹⁶It is noteworthy that in the 1631 edition of Viète's works, edited and commented by Jean de Beau-grand, the formulary expression: "to leave no problem unsolved" appears several times, like a refrain (cf. Sasaki [2003], p. 247). Descartes read Viète's works in this edition, only between 1631 and 1632, and indeed complained with Mersenne about the excessive self-confidence shown by Viète: "... Je vous remercie du liure d'Analyse que m'avez enuoyé; mais entre nous, ie ne vois pas qu'il soit de grande vtilite, ny que personne puisse apprendre en le lisant la façon, ie ne dis pas de *nullum non problema soluere*, mais de soudre aucun probleme, tant puisse-t-il estre facile. Ce n'est pas que ie ne ve'uille bien croire que les auteurs en sont fort scauans, mais ie n'ay pas assez bon esprit pour iuger de ce qui est dans ce livre, non plus que de ce que vous me mandez du probleme de Pappus: car il faut bien aller au dela des sections coniques & des lieux solides, pour Ie resoudre en tout nombre de lignes donnees, ainsi que Ie doit resoudre vn homme qui se vante de *nullum non problema soluere*, et que ie pense l'auoir resolu." (Descartes [1897-1913], vol. 1, p. 245).

¹⁷For more information, see D. Jessep's comments in van Maanen [2006].

¹⁸van Maanen [2006]p. 227.

¹⁹Leibniz, *Fines Geometriae*, in AVII4, 36, p. 595.

I surmise that Descartes' early deliberations, sketched in the letter to Beeckman, can be ascribed to the utopian ideas that we find in Pell and Leibniz. Even if it is a controversial issue whether Descartes' mathematical thought developed without discontinuities in the subsequent years, from the noteworthy but still immature insight from 1619 to its highest mathematical peak reached with *La Géométrie*,²⁰ a kinship can be certainly detected, at least at a programmatic level, between Descartes's earliest programme in geometry and some of the key-points at the core of the mathematical program presented in *La Géométrie*.

Firstly, we can envisage a similarity with respect to the emphasis on the rational classification of problems and techniques and to the requirement to solve each problem according to its own nature. As I will expound in the rest of my chapter, Descartes adhered to these general *desiderata* particularly in *La Géométrie*.

A second motif of continuity between the early programme and the more mature achievements presented in *La Géométrie* concerns the emphasis on the instrumental generation of curves. The invention of new compasses is in fact at the core of Descartes' "new science", in 1619, both because the employment of these devices allowed him to solve, by tracing appropriate curves, many of the questions lying open in the problem-solving configuration of early XVIIth century practice, and because these instruments offered to

²⁰Particularly controversial are the role and significance, for the subsequent development of Descartes' geometric thought, of the *Regulae ad directionem ingenii* (as Bos summarized it: "Descartes' unfinished attempt to formulate rules of reasoning" Bos [2001], p. 261), a text written in latin and dating presumably composed between 1619/20 and 1628 (see Gaukroger [1992b], p. 586), although never published during Descartes's lifetime. The question about what do the *Regulae* tell us concerning Descartes's knowledge of mathematics and his ideal of exactness has been dealt, among others, in Gaukroger [1992a], Bos [2001], in particular chapter 18 (p. 261 ff.), and Rabouin [2010]. Both Bos [2001] and Rabouin [2010] agree upon the fact that one must be very cautious in tracing a continuity between the *Scientia penitus nova* evoked in 1619, the program ventured in the *Regulae*, and the general program expounded in the *Discours de la méthode* and in the *Essais* appended to it. As Rabouin explains: "The general context [of the *Regulae*] is an investigation into what makes possible the unity of mathematics - which is indeed the traditional context of reflection on a possible "general" or "universal" mathematics (...) there is no reason to merge what seem to be different projects (the "entirely new science" of 1619, the *alia disciplina* and the *mathesis universalis* of the *Regulae*, the "general algebra" of 1628) into a single grandiose view culminating in *La Géométrie*" (Rabouin [2010], p. 435). In a sense, Descartes' silence, in the *Regulae*, on some crucial matters bears evidence against the continuity between the project cultivated in 1628 and the later programme developed in *La Géométrie*. To mention few but significant examples, we cannot find any mention, in this text, about the classification of problems based on the classification of curves, nor about the use of algebra as a tool in order to analyze the nature of problems (Rabouin [2010], p. 434, p. 441). Even if it is highly plausible that some of the ideas expounded in the *Regulae* were still considered valid by the later Descartes, yet it is dubious to consider this treatise as an intermediate step between the program for the new science illustrated in 1619 and the programme expounded in *La Géométrie*.

Descartes a rational and expedient means in order to organize geometrical knowledge.

In *La Géométrie*, Descartes circumscribed the curves usable in solving geometric problems to those generated by a well-defined class of devices ("geometrical linkages"), whose paradigmatic example, chosen by Descartes primarily for its illustrative value, was an instrument designed for inserting an arbitrary number of mean proportions (ref.).

As it has been conjectured,²¹ Descartes arguably devised this instrument (or a instrument very similar, for its design and function, to the one depicted in *La Géométrie*) already in 1619-20: it was one of the "new compasses" that he boasted of in the letter to Beeckman. This certainly represents an important link between Descartes' geometry of 1637 and his original project depicted to Beeckman.

Undeniably, though, Descartes deeply reshaped his early program under the urge of methodological and technical acquisitions. In order to show the significance of this reshaping, I will point out two elements of discontinuity between Descartes's geometry of 1637 and his early 1619 program, which constituted fundamental innovations in the development of his mathematical thought.

The first element of discontinuity concerns the exclusion from geometry of certain curves, previously held as fully geometrical. A case at point is the quadratrix, a curve called "imaginary" in 1619, but not explicitly considered, at that time, ungeometrical. Descartes' view about the nature of this curve had changed by 1637, although the quadratrix was still described, in *La Géométrie*, as a curve generated by two independent motions. What change did happen, in Descartes' conception of geometry, that might have led him to consider this curve as illegitimate, and range it among mechanical, or ungeometrical ones?

An answer might be advanced by considering a second element of discontinuity between the earlier programme and its mature development: it concerns the role of algebra, which had become dominant in *La Géométrie*. Not only Descartes devoted a large part of his treatise (especially the third book) to algebraic techniques relating to the solution of equations. Algebra (understood, as I will discuss in more detail below, as a language in order to express proportions in a more compact way) assumed a fundamental method-

²¹ Cf. Bos [2001], p. 240-241.

ological role in establishing a classification of geometrical constructions according to their simplicity, and in permitting a thorough insight into the structure of problems.

3.1 Analysis and Synthesis in Descartes' geometry

3.1.1 Cartesian analysis as transconfigurational analysis

In 1637, Descartes admitted the view, reverberating in his early 1619 deliberations, and common within ancient and early modern mathematics, of geometry as a problem-solving activity. This viewpoint shapes both the surface form of this treatise and the very content of the mathematics dealt with by Descartes.²²

For what concerns the form, it must be observed that *La Géométrie*, without lacking a foundational aim (see previous footnote), does not deploy its content according to an outstanding deductive structure, as the one deployed, for instance in Euclid's *Elements*.

The lack of a clearcut deductive concatenation explains why the order in which the three books appear (namely: "Des problemes qu'on peut construire sans y employer que des cercles & des lignes droites" (book I), "De la nature des lignes courbes (II) and "De la Construction des Probleme solides ou plus que solides" (book III) may not coincide with the order in which they can or should be read: this flexibility in reading had been remarked already by Descartes himself, who, for instance, suggested to Mydorge (one of his early readers) to postpone book II to book III, without any loss in the overall understanding.²³

On the other hand, Descartes did not consider his book as a mere collection of results, but rather he shaped its content according to a method whose core evidently escaped to the ancients' insight:

... ce que je ne crois pas que les anciens aient remarqué, car autrement ils n'eussent pas la peine d'écrire tant de gros livres, ou le seul ordre de

²²It is perhaps too reductive to consider Descartes' treatise merely the display of a method or art of problem solving, as Henk Bos seems to concede: "Descartes wrote his book from a particular view of geometry. He saw geometry as an art of solving geometrical problems". Bos [2001], p. 352. Against this hypothesis, see Panza [2011], where some of the the foundational aspects of Descartes' geometry are discussed.

²³"... on doit aussy lire le troisième livre avant le second, à cause qu'il est beaucoup plus aysé", Descartes [1897-1913], vol. 2, p. 22.

leurs propositions nous fait connaitre qu'ils n'ont point eu la vraye methode pour les trouver toutes, mais qu'ils ont seulement ramassé celles qu'ils ont rencontré.²⁴

We can immediately refer Descartes's criticism to such a treatise as Pappus' *Collection*: a large work, whose structure is however loosely articulated. On the contrary, Descartes placed himself in the opposite position while writing, in the closing lines of this treatise:

Mais mon dessein n'est pas de faire un gros livre, & je tache plutost de comprendre beaucoup en peu de mots: comme on iugera peuestre que j'ay fait, si on considere, qu'ayant reduit a une mesme construction tous les problemes d'un mesme genre, j'ay tout ensemble donné la façon de les reduire à une infinité d'autres diverses; & ainsi de resoudre chacun d'eux en une infinité de façons ...²⁵

It is also interesting to note that Descartes did not essentially develop the results obtained in *La Géométrie*, but rather conceived his program achieved with it. On various occasions, both in *La Géométrie* and in his correspondence, Descartes claimed to have unfolded a general strategy in order to construct any problem of ever higher degree, and thus maintained to have laid the guidelines of an epistemologically accomplished science, in which any question that may be raised could in principle find an answer in virtue of one and the same method.²⁶

Although Descartes admitted that there still remained problems "unsolved", those were either considered "impossible", i.e. problems constitutively outside the boundaries of geometry, or they were judged solvable by applying the method introduced in *La Géométrie*, but only at a cost of greater work.²⁷ This attitude bears a clear resemblance to the intentions expressed in Descartes' 1619 letter to Beeckman, discussed in the previous section.²⁸

²⁴Descartes [1897-1913], vol. 6, p. 376.

²⁵Descartes [1897-1913], vol. 6, p. 413.

²⁶*Cf.*, for instance, Descartes [1897-1913], vol. 6, p. 485, and Descartes [1897-1913], vol. 2, p. 83: "j'en fais la construction - wrote Descartes to Mersenne in a letter from 31 March 1638 - comme les Architectes font les bâtiments, en prescrivant seulement tout ce qu'il faut faire, et laissant le travail de main aux charpentiers et aux masons". Although Descartes is discussing a specific problem, this judgement may hold for any problem which can be treated via the precepts of his method.

²⁷*Cf.* Descartes [1897-1913], vol. 2, p. 90-91.

²⁸Henk Bos has made a similar point, by writing that: "After 1637 Descartes occasionally returned to geometrical matters but he did not essentially develop the results reached in The geometry (...) In the letter to Beeckman of 1619 he had written that he intended to achieve a 'completely new science by which all questions in general may be solved'; this goal he now had reached for geometry, the science which from the beginning inspired his vision of the scientific method" Bos [2001], p. 399.

Therefore, there is room to examine whether and to what extent the cartesian goal for a "new science" is achieved in *La Géométrie*, and his hope about proving "what questions could be solved either in this or that way" is fulfilled by the method applied in this treatise. In order to get a clearer grasp of this position, I will concentrate on book I and II, and successively skip to to book III, in chapter 155 of the present work.

Descartes' principal problem in organizing his treatise is to provide it with structure and limits. *La Géométrie* starts with a clear explanation of how the method for solving any problem in geometry must proceed:

Tous les problemes de Geometrie se peuvent facilement reduire a tels termes, qu'il n'est besoin par après que de connoistre la longueur de quelques lignes droites, pour les construire.²⁹

Descartes' problem-solving strategy, as it is illustrated in the first book of *La Géométrie*, is in fact composed by two parts, which we may call, after the traditional terminology, "analysis" and "synthesis". The analytical part consists in reducing to lines all geometrical objects figuring in a given construction problem, and coding the problem into an equation. In the second part, namely the synthesis, the equation so obtained is solved by constructing a segment by the intersection of adequately chosen geometrical curves, or by finding infinitely many points entertaining with a given configuration of segments certain geometrical relations specified in the equation itself: these points would therefore form a locus described by the equation. In each case, anyway, the geometer can offer a solution to the original problem by solving geometrically the equation obtained from the analysis.³⁰

This description is of course reminiscent of the traditional twin method of analysis and synthesis, known to early modern geometers through ancient mathematical texts and few classical accounts, like the one contained in a famous section of Pappus' Book VII of the *Collection*.³¹

²⁹Descartes [1897-1913], vol. 6, p. 169.

³⁰Descartes [1897-1913], vol. 6, p. 369.

³¹Among the surviving mathematical texts where the argumentative mode of analysis is applied, we can list Book II of Archimedes' *Sphere and Cylinder*, together with Eutocius' commentary on propositions II-1 and II-4, and with Pappus' *Collection*. Also Euclid's *Data* was recognized as a source of theorems applicable in the analysis of plane problems (See Bos [2001], p. 95). The best known exposition of this

This account has been the object, in past and recent years, of an enormous amount of studies to which I am reluctant to add, and it has caught the attention of a larger group of scholars than the sole historians of mathematics;³² hence I will only summarize the main properties of the process of analysis, according to Pappus, and stress some relevant differences with respect to the cartesian model of analysis that shines through *La Géométrie*.

Pappus distinguished, in his account, two kinds of analysis: one called "problematical", and the other one called "theorematical". The case of problematic analysis, to which I will confine myself here, as it seems the most relevant one for Descartes and many early modern geometers, applies to a geometrical problem asking for the construction of a geometric object, satisfying certain spatial conditions relative to other given objects.

This procedure can be thus sketched: the sought-for object of the problem is given at the outset of analysis and represented in a diagram involving the givens too. The initial configuration is eventually extended, via licensed inferences and auxiliary constructions, to another configuration, itself represented in a sub-diagram of the original diagram.

According to Pappus' methodological considerations, analysis does not provide *per se* a solution to the problem at hand, but has to be converted into a synthesis, in which a geometric construction is effectuated. The connection between the analytical and the synthetical part of the method is secured by the fact that analysis is achieved by producing a configuration which shows how the sought-for object can be geometrically related to some of the givens. Hence, the synthesis proceeds by a kind of reversal of the analytical steps: starting from some given objects and data in the configuration with which analysis terminates, it exhibits the sought-for object by licensed constructions,

argumentative strategy is however the one by Pappus'. The seventh book of Pappus collection contains, as the author himself remarked: "Lemmas of the domain of analysis". The book is subdivided into a preface, which contains the well-known exposition of the method of analysis and synthesis, and a list of these books, there follows a series of synopsis of most of these books, and sets of lemma that are deemed necessary for their reading (see Pappus [1986], vol. 1, p. 66ff.).

³²For an annotated biography on analysis, not restricted to mathematics, see Beaney, Michael, "Analysis", The Stanford Encyclopedia of Philosophy (Winter 2012 Edition), Edward N. Zalta (ed.), URL = <<http://plato.stanford.edu/archives/win2012/entries/analysis/>>. Among the works more specifically dedicated to the changes in the method of analysis produced after the incorporation of the algebraic mode of reasoning, we can recall: Hintikka and Remes [1974], Mäenpää [1993] (this work unpublished), Otte and Panza [1997], Bos [2001] and, among the articles specifically dedicated to early modern geometry Panza [2007], Panza [2006], Hintikka [2012].

and thus solves the problem.³³

The form of problematic analysis sketched above is not the only one we encounter in the context of ancient greek geometrical practice. A different type of analysis concerns, for instance, such problems in which a geometric object is sought for, which satisfies purely quantitative conditions, expressible either in the form of proportions between homogeneous geometric objects, or between a pair of homogeneous geometric magnitudes and two numbers, or in the form of equalities between two sums of mutually homogeneous magnitudes.³⁴

As an example of this kind of analysis, let us consider the construction of the problem of inserting two mean proportionals between two given segments related by Eutocius, in his Commentary to the archimedean treatise on the Sphere and the Cylinder, and ascribed by him to Maenechmus.³⁵

The problem goes as follows. Let be two given lines A and E (with $A > E$), it is required to find two mean proportionals B and Γ between them. According to the first step of analysis, let us assume the problem solved. Let a line $O\Delta$ be given in position, and let us trace on it a point N , such that the segment $ON = B$. Let us trace the perpendicular $NP = \Gamma$, as in fig. 3.1.1.

Since we have: $A : B = B : \Gamma$, by hypothesis, we can deduce that the rectangle with sides A, Γ , namely: $R(A, \Gamma)$ is equal to the square with side B , namely: $sq(B)$. Since $NP = \Gamma$ and $ON = B$, we obtain the following equality: $R(A, NP) = sq(ON)$. This equality expresses the symptom of a parabola passing through P , having vertex in O , OM for axis, A for *latus rectum*.

Let us then trace OM and MP equal and parallel to NP and ON , respectively. Since we also have that: $A : B = \Gamma : E$, the rectangle with sides A and E is equal to the rectangle with sides B and Γ . But we have set $B = ON$, so that: $B = MP$, and $\Gamma = NP = OM$. Hence we derive the following equality: $R(A, E) = R(MP, OM)$. This second equality expresses a locus property of an hyperbola which passes through P , with O as center and OM and ON as asymptotes.³⁶

³³The precise logical nature of the process of analysis and synthesis and their mutual relation is still an open problem (See the illuminating studies: Hintikka and Remes [1974], Maenpaa [1997].

³⁴The terminology is due to Panza [2007], p. 116.

³⁵Archimedes [1881], vol III, p. 84-85.

³⁶See also Heath [1981], p. 253-255, and chapter 2, p. 58.

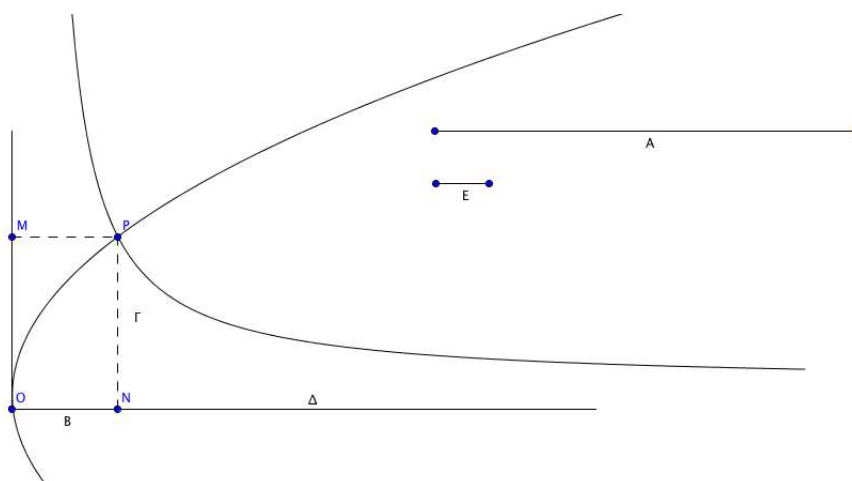

Figure 3.1.1: Insertion of two mean proportionals.

Since the curves are univocally determined in the plane, they can be both constructed in the synthesis, so that their intersection point P can determine the sought for mean proportionals $B(= NP)$ and $\Gamma(= MP)$.

Let us observe that a fundamental step in the analysis of this problem, as reported above, consists in the derivation, from the proportion: $A : B = B : \Gamma = \Gamma : E$, assumed at the beginning of analysis, of the couple of proportions: $A : B = B : \Gamma$ and $A : B = \Gamma : E$, from which the symptoma of the constructing curves can be derived too. The inference leading from the first proportion to the subsequent ones is a non positional one, since it does not depend on the configuration in which the segments A , B , Γ and E appear.

We might thus employ the term: "trans-configurational analysis" in order to refer to this type of transformative analysis, consisting in relying on geometrical non-positional inferences, in order to reduce a geometrical problem which can be formulated in the language of proportions, like the problem of inserting two mean proportionals, into new problem or problems, like that of constructing the curves whose symptoma are expressed by the couple of proportions: $A : B = B : \Gamma$ and $A : B = \Gamma : E$.³⁷

³⁷The term is used in Panza [2006], p. 280, and Panza [2007], p. 121-122.

The cartesian model of analysis may be also conceived as a transconfigurational type of analysis. Descartes sketches his strategy in the following terms:

Ainsi, voulant resoudre quelque problemesme, on doit d'abord le considerer comme deja fait, & donner des noms à toutes les lignes, qui semblent necessaires pour le construire, aussy bien à celles qui sont inconnues, qu'aux autres. Puis, sans considerer aucune difference entre ces lignes connues et inconnues, on doit parcourir la difficulté, selon l'ordre qui montre le plus naturellement de tous en quelle sorte elles dependent mutuellement les unes des autres, jusqu'a ce que'on ait trouvé moyen d'exprimer une mesme quantité en deux facons: ce qui se nomme une Equation, car les termes de l'une de ces deux facons sont esgaux a ceux de l'autre.³⁸

As we read in the passage above, a problem at hand, considered as solved, is reduced via geometrical non-positional inferences not into another geometric problem, but into a finite polynomial equation (namely, "a way to express the same quantity in two manners"), i.e. an algebraic object.³⁹ The equation obtained by "unravelling the problem" (*parcourir la difficulté*) must be then constructed, in order to solve the original geometric question.

³⁸Descartes [1897-1913], vol. 6, p. 300. The general characters of the process of analysis are discussed also in the Rule XVII of the *Regulae ad directionem ingenii*, composed in the late 1620s. Here is how Descartes describes it: "We should make a direct survey of the problem to be solved (*proposita difficultas directè est percurrenda*), disregarding the fact that some of its terms are known (*cogniti*) and some are unknown (*incogniti*), and intuiting, through a train of sound reasonings, the dependence of one term on another (...) the trick here is to treat the unknown ones as if they were known. This may enable us to adopt the easy and direct method of inquiry even in the most complicated of problems. There is no reason why we should not always do this, since from the outset of this part of the treatise our assumption has been that we know that the unknown terms in the problem are so dependent on the known ones that they are wholly determined by them. Accordingly, we shall be carrying out everything this Rule prescribes if, recognizing that the unknown is determined by the known, we reflect on the terms which occur to us first and count the unknown ones among the known, so that by reasoning soundly step by step (*gradatim & per veros discursus*) we may deduce from these all the rest, even the known terms as if they are unknown." (Eng. tr. in Mäenpää P., *From backward reduction to configurational analysis*, in Otte and Panza [1997], p. 207-208).

³⁹I observe that the transformation of a geometrical problem into an algebraic problem abstracts from those particular conditions on the content of the original problem that depend on the relative positions of geometrical objects in a particular configuration: rightly speaking, then, Descartes refers to the transformation of a geometric problem into an algebraic expression by calling it a "reduction". Using a word from logic and computer science, we may say that translation from geometry into algebra is a kind of forgetful translation, namely a translation that removes a specific kind of information. See, for instance Carnielli et al. [2009].

Despite Descartes judged his method "clearer and safer" than the analysis of the ancients and the algebra of the moderns,⁴⁰ the general illustration offered in Book I still contains ambiguous aspects. For instance, it seems that Descartes alludes, by stressing that one must choose "the most natural order" in deriving the equation corresponding to a problem, to the possibility that more than one equation can be obtained from the same problem. But which criterion one must choose in order to avoid equations more complex than necessary? Descartes eschews a direct answer In Book I (this issue will be discussed in book III), and observes, quite mysteriously indeed, that the simplest possible equations corresponding to a problem can be obtained by "making all possible divisions".⁴¹

I will return to this issue in next chapter. In order to illustrate an example of cartesian analysis, let us now consider how he dealt with the classical problem of finding two mean proportionals between given segments a and q , whose solution was known since ancient Greek geometry, and has been discussed also above. The first step is to reduce the problem to an equation:

... si on veut donc suivant cette regle trouver deux moyennes proportionnelles entre les lignes a et q , chacun sait que posant z pour l'une, comme a est à z , ainsi z à $\frac{z^2}{a}$, et $\frac{z^2}{a}$ à $\frac{z^3}{a^2}$, de façon qu'il y a Equation entre q et $\frac{z^3}{a^2}$, c'est à dire $z^3 = a^2q$.⁴²

⁴⁰In his *Discours de la methode*, Descartes observed: "Puis, pour l'analyse des Anciens et l'algebre des modernes, outre qu'elles ne s'estendent qu'a des matieres fort abstraites, & qui ne semblent d'aucun usage, la premiere est toujours si astraite a la consideration des figures, qu'elle ne peut excéder l'entendement sans fatiguer beaucoup l'imagination; et on s'est tellement assueiti, en la derniere, a certaines regles & a certaines chiffres, qu'on en a fait un art confus & obscur, qui embarrasse l'esprit, au lieu d'une science qui le cultive. In particular: " Descartes disparaged the ancients for having concealed their methods of discovery and having proceeded in such an unorderly way in their research, that they wrote too long books: "ou le seul ordre des leurs propositions nous fait connoistre qu'ils n'ont point eu la vraye methode pour les trouver toutes, mais qu'ils sont seulement ramassées celles qu'ils ont rencontrées" (Descartes [1897-1913], vol. 6, p. 376). Although he was not lenient in his criticism of Greek mathematicians, Descartes would also stress a fundamental continuity underscoring his techniques for problem-solving and the techniques of the ancients: "Ils connoissent pas aussy ma Demonstration - Descartes wrote to Mersenne in the already quoted letter from 31 March 1638, referring to his readers - a cause que j'y parle par a b . Ce qui ne la rend toutefois en rien differente de celle des anciens, sinon que par cette façon je puis mettre souvent en une ligne ce dont ils remplissent plusieurs pages, & pour cete cause elle est incomparablement plus claire, plus facile et moins suiète a erreur que la leur" (Descartes [1897-1913], vol. 2, p. 83).

⁴¹Descartes [1897-1913], vol. 6, p. 374: "... pourvû qu'en desmelant ces Equations on ne manque point a se servir de toutes les divisions qui seront possibles, on aura infailliblement les plus simples termes auxquels la question puisse estre reduite".

⁴²Descartes [1897-1913], vol. 6, p. 469.

Descartes' notation is the one we are familiar with, where x, y, z denote unknowns, and letters a, b, c etc. denote known segments. The problem actually asks to solve the problem of inserting two unknown segments denoted by x and z , given two known segments a and q , in such a way that: $a : z = z : x = x : q$. Since the unknown x can be expressed in terms of z and a , so the equation corresponding to the problem will be in one unknown, namely: $z^3 = a^2q$.

This example illustrates how the construction of problems of ancient geometry is amenable to a finite algebraic equation. Descartes claimed that his method of analysis could be extended to problems "not entirely determined",⁴³ namely problems admitting an infinity of solutions, as in Pappus' locus problem. Let us recall that this problem (which includes, in fact, several instances: it constitutes, therefore, a class of problems) is central in Descartes' *Géométrie*: in fact Descartes takes it up as a test-case in order to demonstrate the superiority of his problem-solving strategy with respect to the geometry of the ancients, who lacked a true method in order to discover solutions to problems in an exhaustive and orderly way. In explaining this problem I shall rely on Bos [1981] (p. 299), and Bos [2001] (p. 271ff.). Let a number of lines L_i given in the planes, and let φ_i denote a number of given angles. Let P be a given point, and d_i the line joining P to L_i , and cutting L_i at a fixed angle φ_i (fig. 3.1.1). Let $\alpha : \beta$ be a fixed ratio, and a a given segment. It is required to find points, which satisfy either the following properties:

$$(d_1 \cdot d_2 \dots \cdot d_n) : (d_{n+1} \dots \cdot d_{2n-1} \cdot a) = \alpha : \beta$$

For any given number of odd lines; or the following property:

$$(d_1 \cdot d_2 \dots \cdot d_n) : (d_{n+1} \dots \cdot d_{2n}) = \alpha : \beta$$

For any given number of even lines.

As an example, I will resume, on broad strokes, the statement and analysis of Pappus' problem for four lines (figure 3.1.1).⁴⁴ The problem can be thus related. Given four

⁴³See Descartes [1897-1913], vol. 6, p. 372.

⁴⁴Cf. Bos [2001], p. 272ff., p. 314ff.; Mancosu [1999], p. 69-71; Mancosu [2007], p. 113-114.

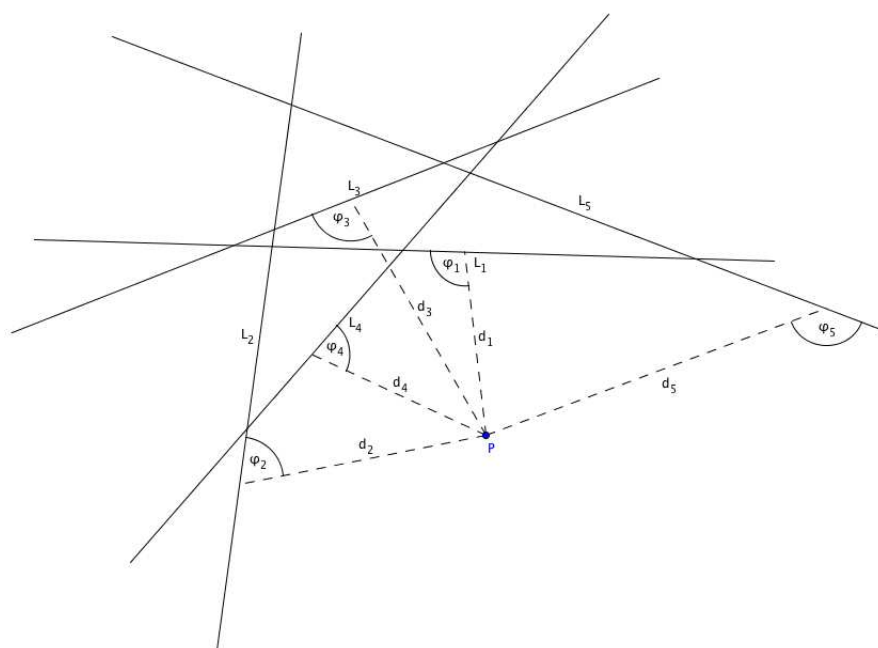

Figure 3.1.2: Pappus' problem in 5 lines.

lines in position (but not in length) AB , AD , EF , GH , and four angles α , β , δ , γ , it is required to find a point C , such that lines CB , CF , CD , CH can be drawn forming angles α , β , δ , γ (as in fig. 3.1.1), and such that the following equality is satisfied:

$$CB.CF = CD.CH$$

This is an instance of 'locus-problem', according to the terminology of the ancients: in fact the problem characterizes a certain relation that a point C possesses, in virtue of its belonging to a special curve. The construction of this curve will eventually solve the problem (in this case a conic section). Descartes, while maintaining the same terminology of the ancients, and while recognizing this problem as a locus problem as well, subtly but thoroughly changed the very concept of 'locus'. As a start, he gave the following definition of locus (*'lieu'*), quite different from the one we can desume from Pappus' or Proclus' accounts:

ces lieux ne sont autre chose que, lorsqu'il ets question de trouver quelque point auquel il manque une condition pour estre entierement determiné (...)

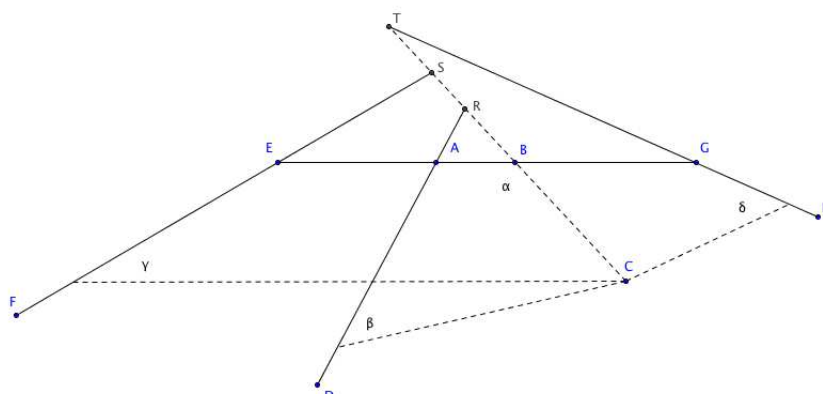

Figure 3.1.3: Pappus' problem in four lines.

tous les points d'un mesme ligne peuvent estre pris pour celuy qui est demandé.⁴⁵

A locus-problem, from Descartes' viewpoint, asks to find points ("trouver quelque point") that obey to specific conditions: more precisely, a locus-problem is an indeterminate problem, and admits infinitely many points as solutions. Proceeding in compliance with the general guidelines of analysis, Descartes starts by supposing: "la chose comme déjà faite", and considers the lines AB and BC as "principal", namely lines in terms of which all the other lines in the configuration are to be expressed. Descartes names segments AB and BC with the letters x and y , and names with other letters (z , b , c , d and so on) the other segments appearing in the configuration of the problem (as depicted in figure). Since the triangle ARB , which pops up in the configuration by a simple elementary auxiliary construction, is such that its angles are known by constructions, the ratio between sides AB and BR is given too. Descartes can thus write down the following proportion: $AB : BR = b : z$. Since $AB = x$, segment BR can be expressed as: $BR = \frac{bx}{z}$. Descartes relies on a chain of similar relations in order to express segments CF , CD and CH in terms of x , y and of the other known segments.

The second step of Descartes' analysis consists in setting the equation $CB \cdot CF = CD \cdot CH$ with the expressions of segments CB , CF , CD and CH obtained in terms of the unknowns x and y . As a result, Descartes obtained an equation in the second degree in

⁴⁵Descartes [1897-1913], vol. 6, p. 407.

x and y . More generally, the analysis of an indeterminate problem, in the context of Descartes' *Géométrie*, yields a polynomial equation of the form: $F(x, y) = 0$.

The synthetic part of the cartesian model in order to solve determinate and indeterminate problems consists in the geometric construction of the equation obtained at the end of analysis. According to the standards in force in early modern geometry, Descartes required to solve the equation through a geometric construction, and not through an algebraic manipulation. The latter solution, which for the problem at hand would amount to express the unknown z as a 'function' of the known terms (for instance: $z = \sqrt[3]{a^2q}$) was judged insufficient and non informative, because it did not tell us how z , corresponding to the real root of the third degree equation, could be constructed, and thus how the original geometric problem could be solved. As I will explain more extensively in the next section, the importance of a geometric solution becomes clearer as we bear in mind that, in the process of translating a construction problem into algebra, letters denoted segments rather than abstract quantities, and equations were primarily shorthand notations for proportions obtaining of segments. Accordingly, in Descartes' synthesis of a determinate problem, the solution to an equation ought to exhibit a geometric magnitude (for instance a segment), that would thus enable to solve the original construction problem.⁴⁶

If we remain to Descartes' general deliberations offered Book I, it seems that once a problem has been reduced to an equation, after having applied all 'possible divisions', its construction could be effected by consequence, in the simplest way.⁴⁷

But Descartes seems to conceal here, with rethorical ability, a real difficulty in the problem-solving practice. For instance, before presenting his solution to the problem of inserting two mean proportionals, by constructing the corresponding equation via the intersection of a circle and a parabola (see chapter 4 for the details of this construction), he warns that solving the same problem by more complex means is configurable as an error in geometry. Yet, as we know from the previous chapter, the mean proportionals

⁴⁶Bos [1984], in particular pp. 339-342. Let us remark that the equation $z^3 = a^2q$ has two solutions in the field of complex quantities (see Stewart [2003], p. 9), whereas we can judge from the examples deployed in *La Géométrie* that Descartes' considerations were confined to the field of real quantities (or on a structure isomorphic to it), where the equations has one solution. The fact that the two imaginary roots of the equation $z = \sqrt[3]{a^2q}$ were not considered in the process of the geometric solution seems to follow from Descartes' emphasis on the geometrical character of the synthesis. What geometric object might correspond to such solutions, in fact?

⁴⁷Descartes even pleads the question as unworthy of being discussed in detail, and leaves it to the student as a delightful and useful exercise (Descartes [1897-1913], vol. 6, p. 374).

problem can be solved, correctly, by several curves: what sort of inference led Descartes to his particular choice, and why did he discard alternative solutions?

Later, in the next chapter, we shall consider this problem more closely. In order to complete my illustration of Descartes' procedures for the construction of problems, I point out that, in the case of an indeterminate problem (reducible, as seen above, to an equation in two unknowns), Descartes' synthesis simply consisted in transforming it into a determinate problem, simply by taking one of the unknowns (generally the one of higher degree) and replacing it by a constant term so as to obtain a new equation in the other unknown. Descartes explained this procedure in book I:

Puis, a cause qu'il y a toujours une infinité de divers points qui peuvent satisfaire à ce qui est ici demandé, il est aussi requis de connoître et de tracer la ligne dans laquelle ils doivent tous se trouver . . . on peut prendre a discretion l'une de deux quantités inconnues x ou y , & chercher l'autre par cete equation (. . .) mesme prenant successivement infinies diverses grandeurs pour la ligne y , on en trouvera aussi infinies pour la ligne x , & ainsi on aura une infinité de divers points (. . .) par les moyens desquels on descriera la ligne courbe demandée.⁴⁸

Iterating this process for arbitrary values of the y , one could obtain a distribution of points on the curve with any required degree of density, namely, a pointwise construction of the curve. It seems, from this procedure, that Descartes might have indulged in a modern conception of locus as an aggregate of points obeying to specific conditions, and which constitute the curve itself. However, other considerations invite to a more cautious interpretation. For instance, on one occasion Descartes clearly reminds to Mersenne that considering a line as the aggregate of all its points *in actu* is mere "phantasy" ("*une imagination toute pure*").⁴⁹ We can conjecture, also in the backdrop of Descartes' way of proceeding in *La Géométrie*, position seems to be that a locus characterized as an aggregate of points, cannot be considered on a par with a curve; curves, in order to enter the number of legitimate geometric objects, must be constructed by a continuous tracing. As I will discuss later, construction of curves will be the central issue discussed in Book II of *La Géométrie*.

⁴⁸Descartes [1897-1913], vol. 6, p. 380, 385.

⁴⁹Descartes [1897-1913], vol. 2, p. 384.

3.1.2 The constitution of the algebra of segments

Descartes grounded the possibility of expressing a problem through an equation (let us think, for instance, of the two mean proportionals problem seen above) on the possibility of employing arithmetical operations in order to denote geometrical constructions. It is important to clarify how Descartes understood the relations between arithmetic and geometry, which, according to him, were grasped only obscurely by the ancients.⁵⁰ Hence we read, in the second paragraph of Descartes' text:

Et comme toute l'Arithmetique n'est composée, que de quatre ou cinq operations, qui sont l'Addition, la Soustraction, la Multiplication, la Division, & l'extraction des racines, qu'on peut prendre pour une espece de division: Ainsi n'at on autre chose a faire en Geometrie touchant les lignes qu'on cherche, pour les preparer a estre connuës, que leur en adjouter d'autres, ou en oster, Oubien en ayant une, que ie nommeray l'unité pour la rapporter d'autant mieux aux nombres, & qui peut ordinairement estre prise a discretion, puis en ayant encore deux autres, en trouver une quatriesme, qui soit à l'une de ces deux, comme l'autre est à l'unité, ce que est le mesme que la multiplication, oubien en trouver une quatrieme, qui soit a l'une de ces deux, comme l'unité est a l'autre, ce qui est le mesme que la Division, ou enn trouver une, ou deux, ou plusieurs moyennes proportionnelles entre l'unité & quelque autre ligne, ce qui est le mesme que tirer la racine quarrée, ou cubique &c.⁵¹

The possibility of equations as meaningful expressions coding relations among segments ultimately rests, for Descartes, on the definitions of specific geometrical operations of sum, product, division, and extraction of square and n roots, which possess the same properties as their arithmetico-algebraic analogues.

In order to do so, Descartes proceeds by stating the necessary and sufficient conditions which any triple x ; a ; b of segments in the plane must satisfy for these operations to hold. Subsequently, he offers geometrical constructions which produce a segment x as the result of, respectively, addition, multiplication, division, or n th root extraction between two given segments a and b .

⁵⁰"Or je vous prie de remarquer, en passant, que le scrupule, que saisoient les anciens d'user des termes de l'Arithmetique en la Geometrie, qui ne pouvoit proceder, que de ce qu'ils ne voyoient pas asses clairement leur rapport, causoit beaucoup d'obscurité, & d'embaras, en la façon dont ils s'expliquoient" (Descartes [1897-1913], vol. 6, p. 378).

⁵¹Descartes [1897-1913], vol. 6, p. 369.

Defining operations of geometrical sum and difference between geometric quantities (like segments or polygons) was not a problem: geometric operations analogous to addition and subtraction can be defined, for instance, by joining two segments AB and CD or by cutting off a segment CD from AB , provided $CD < AB$.⁵²

A fundamental conceptual difficulty from which Descartes had to extricate his geometric algebra occurs with changes in dimensionality introduced by the operations of multiplication and division. Whereas arithmetic quantities are dimensionless, and the product, division (and the extraction of root), in brief, the result of any operatory combination on numbers is itself a number, analogous geometric operations apply to objects of different dimensions: segments, figures in the plane and solids.

In the tradition of geometrical algebra, equations were interpreted geometrically according to the following principle: the unknown x was associated to a segment, x^2 to a square in the plane, and x^3 to a cube in the space. Moreover the multiplication and the division between geometrical magnitudes were not defined so as to preserve homogeneity. For instance, the product of two magnitudes of a given dimension was a magnitude of a higher dimension, and, conversely, the quotient of two magnitudes was not a magnitude of the same dimension of the dividend:

Le produit de deux quantités a et b , respectivement d'ordre m et n est de ce fait identifié à une quantité d'ordre $m + n$; de même, leur quotient est identifié à une quantité d'ordre $m - n$. Ceci conduit naturellement à introduire des restrictions concernant l'addition et la soustraction: deux quantités ne peuvent être additionnées entre elles et l'une d'elles ne peut être soustraite de l'autre qu'à condition qu'elles soient du même ordre.⁵³

In all early XVIIth century attempts at constructing a geometric algebra, which preceded Descartes, the multiplication and division between segments, contrarily to their arithmetic correlates, are not operations preserving homogeneity. It is sufficient to consider the product between two segments, interpreted on the ground of the classical Euclidean canon, in order to see that the result is not a segment anymore, but a surface. Consequently, an expression like $ab + c$, where a, b, c denoted three segments, turned out to be an ill-formed expression in geometry, before the advent of cartesian geometry, as

⁵²These operations rely on Euclid's *El.*, I, 2; *El.*, I, 3.

⁵³See Panza [2005], p. 22. In particular, see Freguglia [1999a], p. 153-155, for an overview of the principle of dimensionality.

it is inconceivable to sum a one-dimensional magnitude with a two-dimensional one. A correct geometric interpretation of the above expression would consist, according to the constraints in homogeneity, in interpreting ‘ a ’ and ‘ b ’ as segments, and ‘ c ’ as a figure in the plane.⁵⁴

The introduction of a unity segment constitutes the crucial step in Descartes’ procedure of encoding geometrical relations into algebraic operations. As it occurs with the ordinary product and quotient between numbers, the product and quotient of two segments, and, more generally, between two arbitrary homogeneous magnitudes, can yield a magnitude homogeneous with the given previous ones, provided a unitary magnitude is introduced. Consequently, even if homogeneity is not abandoned, its fulfilment becomes almost trivial:

Il est aussy a remarquer que toutes les parties d’une mesme ligne, se doivent ordinairement exprimer par autant de dimensions l’une que l’autre, lorsque l’unité n’est point déterminée en la question (...) mais que ce n’est pas de mesme lorsque l’unité est déterminée, a cause qu’elle peut estre soustendue par tout ou il y a trop ou trop peu de dimensions: comme s’il faut tirer la racine cubique de $aabb - b$, il faut penser que la quantité $aabb$ est divisée une fois par l’unité, & que l’autre quantité b est multipliée deux fois par la mesme.⁵⁵

In this context, the role of unity looks more similar to the role of a multiplicative unity within a semi-group, than the one of a number expressing the measure of a length. This role clearly shines through the definitions of product and quotient stated in the beginning of *La Géométrie*. Fundamentally, the necessary and sufficient conditions imposed to a quadruple of magnitudes $(x; a; b; 1)$ for x to be either the product or the quotient of a and b , or the n -th root of either a or b , where 1 is the unity (note that here the symbol ‘1’ is simply a name, that can be substituted by any other letter) boil down to their codability into proportions. More specifically, given three homogeneous magnitudes $a; b; 1$, Descartes defines the product between a and b as a magnitude x satisfying the following proportion:

⁵⁴In slightly anachronistic terms, we could say that, in renaissance and early modern geometry, before 1637, whereas arithmetic was endowed with the structure of a field (with addition and multiplication), geometry had the structure of a group (or semi-group) with respect to addition defined in the domain of segments or polygons, for instance. The product between two segments, on the contrary, was not defined as a segment: the operation of multiplication was not an internal operation in Euclid’s geometry, which cannot be endowed with the structure of a field.

⁵⁵Descartes [1897-1913], vol. 6, p. 299.

$$(ab = x) =_{df} (1 : b = a : x).$$

The quotient between two homogeneous magnitudes a and b can be defined along a similar line:

$$\left(\frac{a}{b} = x\right) =_{df} (x : a = 1 : b).$$

And so can be defined the extraction of the n -root (where n is a natural number) of a magnitude a :

$$(\sqrt[n]{a} = x) =_{df} (1 : x = x : x_1 = x_1 : \dots : x_{n-2} : a).$$

With the above definitions, Descartes confines himself to show that the operation of dividing a magnitude by another, homogeneous magnitude is tantamount to establishing a proportion between these magnitudes, the result of this operation and the unity. A similar case occurs in the case of root extraction: extracting the n -th root of a magnitude a is equivalent to establish a proportion between 1, a and $n - 2$ mean terms.

I observe that, in virtue of these definitions, expressions like: "the magnitude x is the product of the magnitudes a and b " or " x is the cube root of a " remain meaningful, even if it is not known how to exhibit this magnitude through a geometric construction, since, as observed by M. Panza: "lorsqu'une proportion porte sur des quantités d'un genre particulier, elle dit en effet quelque chose de ces quantités; en particulier, elle dit que ces quantités satisfont certaines conditions définies en termes de l'opération d'addition, de la relation d'égalité, et de la relation d'ordre qui sont définies sur elles".⁵⁶ An algebra thus defined can be called, following the suggestion in Panza [2005] (p. 25-26), an *assertive algebra*.⁵⁷

The reason for this terminology is clear if we consider that Descartes construes, at the outset of *La Géométrie*, a formalism which enables him to rewrite polynomial equations as a proportion or a system of proportions, and conversely, to code any proportion or system of proportions into equations.⁵⁸ On this ground, in fact, one can say that an

⁵⁶Panza [2005], p. 25.

⁵⁷The word "assertive" is my rendering of the french term "assertif" employed in Panza [2005]. I surmise that the english term, which the *Oxford Dictionary* supplements with the following definition: "characterized by mere assertion" conveys the original meaning in a fairly acceptable way. Descartes' definitions allow one to specify several special geometric "assertive" algebras, all sharing the same structure.

⁵⁸Panza [2005], p. 25.

expression like $z^3 = a^2q$ asserts something about z as a magnitude of a certain kind (for instance, that the magnitude z appears in a certain proportion, or chain of proportions) even if it is not known how z might be constructed.

I do not exclude that Descartes conceived also a different view of algebra, understood not as a theory of quantities, but as a theory of operations governing these quantities, or the structure common to the several assertive algebras.⁵⁹ Nor I exclude that Descartes took over the study of algebraic objects understood in this sense. On the contrary, in Book III of *La Géométrie* Descartes defined equations independently from their geometrical references, as:

. . . sommes composées de plusieurs termes, partie connus et parties inconnus, dont les uns sont esgaux aux autres, ou, plutost, qui, considérés, sont esgaux a rien.⁶⁰

Such definition emphasizes a formal conception of equation, since it refers only to literal signs and numbers (*termes*) as well as to operations among them. A similar remark holds for those rules of transformation and algebraic reducibility, exposed and commented by Descartes in the same book, which allow one to work on the structure of the equation as an object *per se*.⁶¹

It is beyond my purpose to study here this idea of algebra and Descartes' related achievements. I will rather consider, in the next section, a second fundamental step undertaken by Descartes in the first Book of *La Géométrie*. As I have observed, the definitions just given of product, quotient and root extraction are not constructive, in the sense that they do not contain the instructions for exhibiting the results of the operations defined,

⁵⁹This idea of algebra incorporates certain aspects of what Mahoney characterized as the "algebraic mode of thought": "this mode of thought is characterized by the use of an operative symbolism, that is, a symbolism that not only abbreviates words, but represents the working of the combinatory operations or, in other words, a symbolism with which one operates . . ." (Mahoney [1980], p. 142). According to the suggestion I want to convey, the algebra employed in the study of geometric problems (therefore in the first two books of *La Géométrie*) was not merely a formal theory of operations. In order to make things clearer, we may recur to the useful analogy introduced by J. Macbeth: "whereas Viète's *logistique speciosa* functions as an uninterpreted calculus, one that can be interpreted either geometrically or arithmetically, Descartes' symbolic language is always already interpreted" (Macbeth [2004], p. 99).

⁶⁰Descartes [1897-1913], vol. 6, p. 444. As K. Manders observed, this definition complies with: ". . . the most obvious feature of polynomials, consist quantities and equations (...) as sums or aggregates of terms, and have roots, which are typically sought", Manders [2006], p. 187.

⁶¹Descartes introduced the following degree-general transformations as rules of thumb: the sign of rule (i), its reverse (ii), the substitution of $x + a$ for x (iii), its effects and applications (Descartes [1897-1913], vol. 6, p. 373, 374-378). See also Manders [2006], p. 197ff.

when quantities a or b are quantities of a certain kind, for instance, segments. In Book 1 Descartes proceeds to constructively define the operations of addition, subtraction, multiplication division and extraction of square roots as internal operations within the class of segments. In the successive Book 2 he will show how the extraction of any root of the form $\sqrt[n]{a}$, with n natural number, can be exhibited in geometry too. Descartes obtains in this way a "determinative" algebra of segments, namely an algebra in which it is possible to exhibit, by means of accepted geometric constructions, the result of any operation on given segments, perfectly isomorphic to the arithmetical algebra.⁶²

3.1.3 The construction of the 'four figures'

The second fundamental moment of Descartes' geometry, after the redefinition of the five arithmetical operations between magnitudes, consists in supplementing these definitions with geometrical constructions. In order to do so, Descartes confines himself to the class of segments in the plane. Given two segments in the plane, denoted by a and b , it is easy to define addition and subtraction as geometric operations between them: Descartes interprets the sum $a + b$ as a segment c obtained by juxtaposing segment b to segment a (the operation is licensed by Euclid, *Elements* I, 2).

The geometric interpretations of multiplication, division and square root extraction between two segments rely, on the other hand, on Book VI of Euclid's *Elements*. Thus, given a triple of segments $a, b, 1$, the multiplication between a and b can be defined in the following way. Let two segments $BC = b$ and $BD = a$ be drawn under any angle, as in figure 3.1.3, and let the segment $BA = 1$ be traced. Let the segment CA be traced. From point D , let a segment parallel to CA be traced and let the intersection with the segment BC extended be called E . The product ab will be defined as the segment $BE = x$.

The same configuration allows the geometer to define the division between segments a and b . Indeed, if we set: $BE = b$, $BC = 1$, $BD = a$, the quotient $\frac{a}{b}$ can be interpreted geometrically as the segment $BA = x$.

⁶²Panza [2005], p. 23. By "arithmetical algebra" I am referring to a symbolic language together with a set of rules and techniques for forming and manipulating complex expressions - therefore, what we may call a syntax- in order to deal with problems concerning numerical quantities (a developmental history of this discipline is briefly sketched in Panza [2005], p. 9-12). My choice of "determinative", on the other hand, translates the french "déterminatif" originally employed in Panza [2005]. According to the Oxford Dictionary, determinative is defined as "Serving to limit or fix the extent, or the specific kind or character of anything: said of attributes or marks added with this purpose". I assume that my translation conveys the original meaning with sufficient clarity.

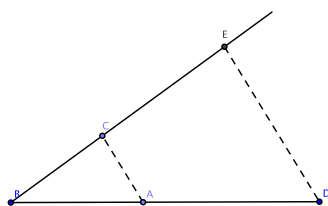

Figure 3.1.4: Descartes' treatment of product and division.

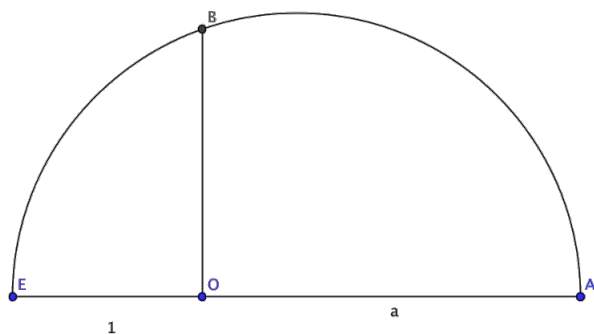

Figure 3.1.5: Square root extraction.

The operation of square root extraction between segments is defined in *La Géométrie* in these terms: let a segment $AO = a$ and an adjacent segment $OE = 1$ be constructed. Let us then trace a circle with diameter AE , and from point O , let the perpendicular to AE be traced, which intersect the circle in B . The segment OB will be the square root of a . Again, the definition of square root extraction rely on a Euclidean construction, exposed in *Elements*, VI, 13.⁶³

After the constructive definition of the operation of square root extraction, given at the beginning of book I, Descartes refrains from supplementing a constructive definition for the operations of extracting the n -th root of a segment:

⁶³Heath [1956 (first edition 1908)], book VI, 13.

...Je ne dis rien icy de la racine cubique ny des autres, a cause que i'en parleray plus commodement cy-aprés.⁶⁴

He will indeed resume the problem in the Third book. Cubic and n -th root extraction (where n is a natural number different than 2^m , for m natural) represents indeed an interesting phenomenon in Descartes' geometry. In the previous paragraphs, I have used the term "constructive definition" in order to refer to the geometric interpretation of the operations of addition, multiplication, division and square-root extraction as operations occurring among segments. For the sake of precision and coherence with my previous terminology, I will rather use, following again Panza [2005], the expression *determinative algebra* in order to denote an algebra where it is possible to exhibit, through standard constructions, the result of any operation between given quantities.

If Descartes' geometry relied solely on the constructions licensed in Euclid's geometry or, to use a pappusian terminology, on 'plane' constructions, the algebra of segments would fail to be a determinative algebra. Indeed, Euclid's plane geometry fails to supplement a constructive definition already for the extraction of the cubic root of a segment, since the problem of inserting 2, 4 and in general $2n$ mean proportions cannot be solved by ruler and compass, employed according to Euclid's constructive clauses.

Descartes was well-aware of this impossibility, already asserted in Pappus' *Mathematical Collection* (see this dissertation, chapter 1, section 1.4, for instance), and for which he even provided an argument in the third book of *La Géométrie*.⁶⁵ Therefore, he tackled, in the second Book of this treatise, the methodological problem of extending the constructive methods admissible in geometry beyond the limits of Euclid's constructive clauses, in order to endow the algebra of segments with its determinative character.

3.2 Descartes' construal of geometricity in 1637

3.2.1 Euclidean restrictions reconsidered

But how to effectuate such extension? Descartes' response depended on the answer to a second question, that he tackled in the second book of *La Géométrie*: 'which curves can be received in geometry?'⁶⁶

⁶⁴Descartes [1897-1913], vol. 6, p. 371.

⁶⁵Descartes [1897-1913], vol. 6, p. 475.

⁶⁶Descartes [1897-1913], vol. 6, p. 388

In asking this question, Descartes was continuing, albeit on a different plane of abstraction and generality, a long debate concerning the role and classification of curves in the solution of problems, that was transmitted to early-modern mathematicians such as Viète, Marino Ghetaldi, Johannes Kepler, and Fermat by way of Pappus.⁶⁷ Descartes directly confronted with Pappus' considerations on the ordering of problems, offered in third and in fourth books of the *Mathematical Collection*. If Descartes praised the pappusian viewpoint of classifying problems on the basis of the curves required for their constructions, he had also few reservations about the traditional views on curves:

Les anciens ont fort bien remarqués, qu'entre les Problemes de Geometrie, les uns sont plans, les autres solides, et les autres lineaires, c'est a dire, que les uns peuvent estre construits, en ne tracant que des droites, et des cercles, au lieu que les autres ne le peuvent estre, qu'on n'y employe pour le moins quelque section conique; ni enfin les autres, qu'on n'y employe quelque autre ligne plus composée. Mais je m'étonne de ce qu'ils n'ont point outre cela distingué divers degrés entre ces lignes plus composées, et je ne saurois comprendre pourquoy ils les ont nommees mechaniques, plustost que Geometriques.⁶⁸

In the above passage, we can distinguish two types of inroads made by Descartes against the "ancients". Firstly, Descartes blamed ancient geometers to lump together curves which should be more properly separated in distinct classes. Secondly, he contested to them the fact of having called "mechanical", and cast out of geometry all those curves "more composed" than straight lines and circles. Few lines later, Descartes suggested that ancient geometers had some compunction also in countenancing the conic sections among geometrical curves.⁶⁹

Descartes did not deny that some curves ought to be excluded from geometry and ranged in Mechanics: he was in fact convinced that the quadratrix, the spiral, and few kindred curves (although never specified in *La Géométrie*) did not fit the bill for geometricity. Nevertheless, Descartes considered overrestrictive and unjustified the traditional restriction to the straight lines and circles as the sole acceptable constructive means.

According to Molland's careful analysis (Molland [1976], in particular p. 35) Descartes committed a blatant error in attributing to the ancients the view that curves more com-

⁶⁷Guicciardini [2009], p. 42.

⁶⁸Descartes [1897-1913], vol. 6, p. 388.

⁶⁹Descartes [1897-1913], vol. 6, p. 389.

plex than circles and straight lines were mechanical rather than geometrical. Confining myself to the *Mathematical Collection*, presumably one of the main sources of Descartes' knowledge about ancient geometry, I notice that Pappus shows few or no explicit qualms about admitting curves like conic sections or linear curves in geometry, although plane means of construction had traditionally enjoyed a theoretical primacy among geometrical method.

However, even if Molland's criticism is correct, on the historiographical level,⁷⁰ it is questionable whether one should speak of an "error" on Descartes' side. In fact, Descartes' assessment of the ancient mathematics of higher curves might be as well rooted in a *communis opinio* of XVIIth century.⁷¹

It may also be possible that the criticism to the "ancients" concealed Descartes' disapproval towards a construal of geometricity adopted by some of his contemporaries instead. This conjecture cannot be easily settled because, as far as it could be ascertained, mathematicians from XVIth and early XVIIth century did not propose positive criteria to assess acceptable geometrical constructions.⁷²

However, some light on this matter can be shed by Descartes' *Géométrie* itself. In fact, after having criticized the view of the ancients, Descartes sets out to carefully debunk, in

⁷⁰ Cf. also Sefrin-Weis [2010], p. 226. An different stance than that endorsed by Molland is held by V. Jullien, who remarks: "Lorsque celui-ci [Descartes] reproche aux anciens de n'avoir pas véritablement reçu les courbes dans leur géométrie, il a raison; mais c'est surtout dans la mesure où un tel programme d'étude (étude intrinsèque des courbes comme objets déterminés) n'était pas, pour eux, à l'ordre du jour" (Jullien [1996], chapter 2, "Critique de la Géométrie classique"). If my understanding of Jullien's viewpoint is correct, the chore of Descartes' criticism to the ancients may be resumed, for him, in these words: the ancients lacked a sufficiently general definition of curve, which could also ensure a systematic classification.

⁷¹ A similar idea was ventured, by the end of XVIth century, by François Viète (1540-1603). Viète remarked, while discussing the problem of cube duplication in his *Variorum de rebus mathematicis responsorum* (1593), that the ancients believed the problem of doubling of the cube to be an irrational (ἄλογον) and an unspeakable (ἄρρητον) problem: "not because it cannot be explicated in numbers, as lines are called irrational, but because its structure is devised not by reason but by an instrument" ("Non quod numeris explicari non possit, ut γραμμαὶ ἄλογοι dicuntur, sed cujus fabrica non ratione, sed instrumento constituatur". Viète [1646], p. 348). The view that ancients restricted geometrical curves to the sole straight lines and circles might go well into XVIIth century and in the XVIIIth. For instance, still in XVIIIth century, Claude Rabuel, in his *Commentaires à la Géométrie de M. Des Cartes* (1730), accepted an analogous view as an alleged historical fact: "Les Anciens Geometres n'ont appelé Geometriques, que ce qui se fait avec la Regle & le Compas; nulle autre operation n'estoit Geometrique; de toutes les lignes, la droite et la circulaire estoient les seules Geometriques. toutes les autres lignes courbes (...) passoient pour mécaniques, & toute Operation, par laquelle on les employoit, estoit aussy appelée mécanique" [Rabuel [1730], p. 97].

⁷² Cf. in particular, Bos [2001], p. 34-36.

the second Book of this treatise, three arguments for the alleged theoretical primacy of constructions by Euclidean means, that might as well have circulated among geometers between XVIth XVIIth century.

Firstly, Descartes attacks against the idea that only the straight line and the circle ought to be considered properly geometrical curves because they can be generated without the appeal to instruments ("machines", in the french text).⁷³ But if one labels a procedure or a construction "mechanical" and excludes it from geometry provided it makes appeal to an instrument - Descartes remarks - then constructions employing circles and straight lines according to Euclidean clauses should be considered mechanical as well, as far as the constructions licensed by Euclid's three constructive postulates can be seen as derived, by way of abstraction, from operations mediated by specific instrument, namely the ruler and the compass.⁷⁴

One may object, Descartes retaliates, that the difference between ruler and compass constructions and constructions by more complex instruments boils down to a matter of precision or accuracy. In order to debunk this claim, Descartes resorts to a conceptual distinction that will indeed turn out to be constitutive of his ideal of geometry:

... Ce n'est pas non plus, a cause que les instruments, qui servent à les tracer [namely, to trace higher curves], estant plus composés que la regle

⁷³Descartes [1897-1913], vol. 6, p. 389. This view might have been shared by at least some of the early modern geometers Descartes could know of. For instance, R. Bombelli (1526-1572) remarks, in his *Algebra* (1572), that contemporary solutions to the problem of inserting two mean proportions had been found only "instrumentally" ("instrumentalmente", in Bombelli [1579], p. 48), and therefore not geometrically. Analogous statements are encountered in the third and fourth book of Stevin's *Problematum Geometricum... libri V* (1583), where Stevin claimed that solid problems were: "... found (...) not by a Geometrical method ..." but by means of instruments, instead (Stevin [1958], vol. 2, p. 301).

⁷⁴I note that neither the ruler nor the compass are mentioned, as instruments devoted to the construction of curves, neither in Euclid's *Elements*, nor in Pappus' discussion of plane geometry, although the first does not eliminate, from the *Elements*, the appeal to mechanical conceptions, like the rotation of plane figures around fixed axes for the generation of solids (*Elements*, XII, Df. 18. See also Apollonius' *Conics*, Book I, Df. 1). As an aside, I observe that I have not been able to find, in the panorama of historical studies, a precise reconstruction of the route through which tracing devices entered mathematical discourse as objects of study - for instance in connection with their constructing power. Certainly Descartes' geometry gave an important contribution to this field of study by associating his criterion for geometricity to the constitution of devices for tracing curves, as I will explore below. Another direction of study, not taken over in this dissertation, but still worthwhile to be investigated, in my conviction, would concern the study of the kinds of problems solvable by different employments or suitable modifications of the Euclidean collapsible compass: what problems are and can be solved, for instance, using the ruler and a compass with a fixed opening? On the other hand, what problems are solvable by restricting the clauses for licesing legitimate constructions to the sole use of the compass for the tracing of circles, thus excluding the ruler and the straight lines as solving means?

et le compas, ne peuvent estre si justes; car il faudroit pour cete raison les reietter des mechaniques, où la justesse des ouvrages qui sortent de la main est désirée; plutost que de la Geometrie, ou c'est seulement la iustesse du raisonnement qu'on recherche.⁷⁵

I have already distinguished, at the beginning of chapter one, a concern for exactness in problem solving from a concern for accuracy or precision. Due to its importance, this conceptual distinction ought to be stressed once more. By considering geometry as an exact discipline, Descartes is not contrasting accurate versus approximate procedures.⁷⁶ geometry - insists in fact Descartes - does not pursue the practical accuracy of a construction ("la justesse des ouvrages qui sortent de la main"), which is the highest attainable virtue in mechanics, but the exactness of reasoning ("la justesse du raisonnement") which must obtain of every geometrical procedure. In the light of this ideal of geometry, it made no sense to exclude a curve because the instrument employed for its tracing could not assure a precise construction as the one granted by the ordinary compass and straightedge.

Thirdly and finally, Descartes suggests that the geometers' restrictions to the straight lines and the circle as the unique means of construction might be rooted in the desire to keep to a minimum the clauses licensing geometrical constructions, and to avoid enriching geometry with more postulates beyond those established in Euclid's *Elements*. However this argument, based on what one might call the 'logical simplicity' of geometry, runs against the very practice of geometers:

... je ne dirai pas aussy, que ce soit a cause qu'ils n'ont pas voulu augmenter le nombre de leurs demandes, & qu'ils se sont contentés qu'on leur accordait, qu'ils pussent joindre deux points donnés par une ligne droite, & descrire un cercle d'un centre donné, qui passait par un point donné, car ils n'ont point fait de scrupule de supposer, outre cela, pour traiter des sections coniques, qu'on pust couper tout cone donné par un plan donné...⁷⁷

⁷⁵Descartes [1897-1913], vol. 6, p. 389. I have not been able to trace, among early-modern geometers before Descartes, any explicit argument that explicitly excluded higher curves because their tracing was imprecise.

⁷⁶I do not fully agree, therefore, with the claim advanced by M. Baron (Baron [1969], p. 163), for whom Descartes was: "... always careful to distinguish between *precision* methods and *approximate* method in mathematics". The turning point in Descartes' conception of mathematics was not, I surmise, the distinction between precise and approximate methods, but between exact and non-exact procedures and objects.

⁷⁷Descartes [1897-1913], vol.6, p. 389. I note that Descartes lists here only the first and the third of

Once demoted these counterarguments, Descartes turned to the *pars construens* of his programme. Firstly, he conceded that the ancient decision (he plausibly had in mind Pappus' book IV of the *Collection*) to exclude from geometry certain curves, like the spiral or the quadratrix, obeyed to a well-grounded rationale, since these curves are imagined as: "describes par deux mouvements séparés & qu' en ont entre eux aucun rapport qu'on puisse mesurer exactement".⁷⁸ On the other hand, curves receivable in geometry are singled out by Descartes on the ground of specific properties of their genesis:

il n'est besoin de rien supposer pour tracer toutes les lignes courbes, que ie pretens icy d'introduire, sinon que deux ou plusieurs lignes puissent estre mües l'une par l'autre, & que leur intersection en marque d'autres (...). Mais il est, ce me semble, très clair, que prenant comme on fait pour Géométrie ce qui est précis et exact, et pour mécanique ce qui ne l'est pas; et considérant la Geometrie comme une science, qui enseigne généralement à connoître la mesure de tous les cors, on n'en doit pas plutot exclure les lignes les plus composées que les plus simples, pourvu qu'on les puisse imaginer estre descriptes par un mouvement continu ou par plusieurs qui s'entresuivent et dont les derniers soient entièrement réglés par ceux qui les précèdent, car par ce moyen on peut toujours avoir une connaissance exacte de leur mesure.⁷⁹

This passage has been given several interpretations,⁸⁰ which contribute to underline its importance for the understanding of Descartes' overall mathematical project. For the sake of my argument, I will limit to depict the standard of geometricity which shines forth through the previous passage.

In Descartes' view, not only straight lines and circles must be included among acceptable solving methods in geometry, but also all the curves that can be constructed on the basis of a definite rule, that we may call 'exactness norm',⁸¹ establishing that "two lines can

the five Euclidean postulates. However uses of the second postulate ("to produce a finite straight line continuously in a straight line") are implicit in the text (for instance, at p. 320, one must concede the possibility of extending straight lines KL and BA continuously into a straight line, in order to enable the tracing of the hyperbola, there at stake). The reference to the sectioning of a cone by a plane is of course to Apollonius' *Conics*, Book I, Df. 1.

⁷⁸Descartes [1897-1913], vol. 6, p. 390.

⁷⁹Descartes [1897-1913], vol. 6, p. 388.

⁸⁰See for instance: Serfati [1993], Serfati [2002] in [Serfati and Bitbol [2002], p. 39-104] Bos [2001], Panza [2005], Panza [2011] (this is a non exhaustive list).

⁸¹I deem, following the enlightening discussion in Panza [2011], that the expression 'exactness norm' should be preferred to 'postulate' (or even to 'axiom', suggested in Boyer and Merzbach [1991], p. 315) because Descartes - unlike Apollonius, whose definition 1 of the *Conics* is evoked above - is not directly

be moved one onto the other, so that their intersections will trace others".

Consider, for instance, the following curve-constructing device, introduced in *La Géométrie* as the first instance of a compass complying with Descartes' exactness norm.⁸² This instrument is never called with a proper name in *La Géométrie*. I will call it hereinafter "proportions compass",⁸³ since it is conceived for the purpose of constructing an arbitrary number of mean proportions between two given segments.⁸⁴

Following the figure reproduced in book II, we can describe the proportions compass as follows. Consider two rulers YZ and YX pivoting around Y . At point B of YX a ruler BC is fixed perpendicularly to YX . A number of sliding rulers CD , EF , GH are inserted along YZ , and similar sliding rulers DE and FG are inserted along YX , perpendicularly to it. When YZ is fixed and the ruler YX rotates around Y , BC is supposed to push DC along YZ , CD then pushes DE along YX , DE pushes FE , in such a way that the angles formed by the rulers with rulers YZ and YX remain constant. Points B , D , F and H are thus supposed to trace in a continuous way a family of curves, each of which is receivable in geometry.⁸⁵

Descartes in fact observes:

... je ne voy pas ce qui peut empêcher, qu'on ne conçoive aussi nettement, et aussi distinctement la description de cette première, que du cercle, ou du moins que de sections coniques, ny ce qui peut empêcher, qu'on ne conçoive la seconde, & la troisième, & toutes les autres, qu'on peut décrire, aussi bien que la première, ny par conséquent qu'on ne les reçoive toutes de même façon, pour servir aux spéculations de Géométries.⁸⁶

establishing which curves should be included in geometry, but fixing a criterion in order to decide the permissible constructions, through which curves are to be described and hence ranged among legitimate geometrical arguments.

⁸²Descartes [1897-1913], vol. 6, p. 391.

⁸³Panza [2011], p. 74.

⁸⁴Descartes [1897-1913], vol. 6, p. 443. A previous version of this compass was probably envisaged by Descartes' manuscript notes now known as *Cogitationes privatae*, dating back to the beginning of the 20s.

⁸⁵Descartes [1897-1913], vol. 6, p. 391.

⁸⁶Descartes [1897-1913], p. 392. I note, on this concern, that these instruments cannot obtain objects in the "pointing way", and consequently cannot enter directly in the problem-solving activity, but only through the mediation of the curves described by them.

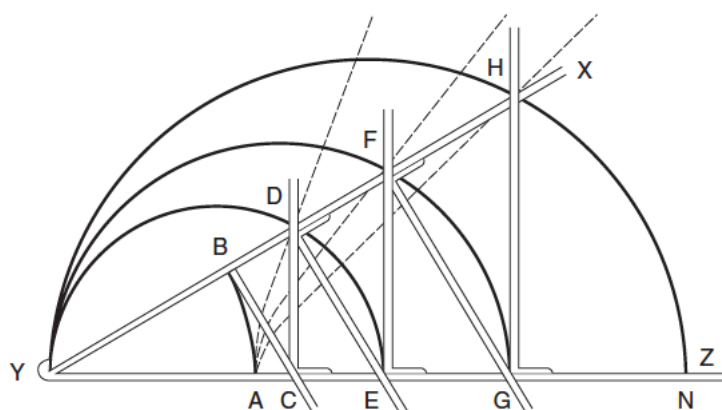

Figure 3.2.1: Descartes [1897-1913], vol. 6, p. 391.

Roughly speaking, Descartes' reasoning can be interpreted as the attempt at taking the clauses stated in Euclid's postulates (licensing ruler and compass constructions) as a basis for iterative constructions describing other curves, different from straight lines and circles, with which, nevertheless, share the same character of exactness.

Indeed, if we grant the acceptability in geometry of the ruler and the compass, employed, according to the clauses established in Euclid's postulates, as instruments for the tracing of straight lines and circles, then the more composite devices ought to be accepted as well, provided they are construed as systems of rulers allowing one degree of freedom movements between the two links that they connect.

For reasons that my discussion has now made obvious, this criterion of acceptability can be called by 'coordinated continuous motion'⁸⁷ or 'by reiterated ruler and compass'.⁸⁸ Moreover, the instruments which realize these criteria can be called 'geometrical linkages'.⁸⁹

⁸⁷This terminology is used by Henk Bos. See Bos [2001], p. 336.

⁸⁸The name has been given by Panza. See Panza [2005], pp. 63, 64.

⁸⁹On the meaning of the term 'linkage' in the mathematical literature, Courant and Robbins write [in Courant and Robbins [1996], p. 155]: "A linkage consists of a set of rigid rods, connected in some manner at movable joints, in such a way that the whole system has just enough freedom to allow a point on it to describe a certain curve". In their discussion, Courant and Robbins do not refer directly to Descartes, but to a discussion occurring much later, well into XIXth century, concerning whether a system of connected rulers could be conceived in order to trace a straight line (Courant and Robbins [1996], p. 156-7). The problem is certainly relevant (see the classical Kempe [1877]), but did not directly concern Descartes' geometry, though, since the constructability of a segment that can be arbitrarily extended is grounded on Euclid's postulates, and it is therefore the basis for more complicated constructions.

The generation by geometrical linkages is not the only way of constructing geometrical curves discussed by Descartes, although it has a clear foundational primacy over other methods.⁹⁰ It is therefore important to understand some of the most noticeable properties of the constructions produced by geometrical linkages.

I observe, as a starting point, that a constructional device as the proportion compass not only assures continuous motions, but assures the tracing of each curve described by the moving points $D, F, H \dots$ according to a *unique* continuous motions. This is due, I surmise, to two relevant conditions which geometrical linkages comply with.

Firstly, these instruments must be so conceived that the local motions of any of their parts are dependent on a principal motion. In the case of the proportion compass, for instance, the principal motion is imparted by the rotation of the ruler YX , which governs the sliding motions of the interconnected rulers.⁹¹

A survey of the other linkages⁹² described in *La Géométrie* allows one to easily identify, for each examined device, a principal motion on which local motions depend. Consider, for instance, the following device introduced by Descartes in order to construct a branch of hyperbola (GCE in fig. 3.2.1). The compass employed is formed by a pivoting joint GL hinged at a segment CL sliding vertically along AB . In Descartes' account, given in Descartes [1897-1913], vol. 6 (p. 393) a principal motion can be easily identified: it is the rotation of the ruler GL , which enables the connected ruler to translate along AB .

⁹⁰Descartes also discussed constructions of curves based on the construction of finitely many points on the curve and constructions based on strings (Cf. especially Bos [1990] and Mancosu [2007]). Some of these constructions will be evoked in the following sections and chapters.

⁹¹As we read in *La Géométrie*: "a mesure qu'on l'ouvre [namely, the linkage depicted in fig. 3.2.1] la reigle BC , qui est jointe a angles droites avec XY pousse vers Z la reigle $CD \dots$ ". It clearly appears from Descartes' description that a principal motion can be singled out, namely the pivoting of XY around Y .

⁹²It must be stressed that one cannot find in *La Géométrie* a catalogue of curves, nor a systematic description of their generation by linkages. Descartes offers only few examples of linkage constructions, and assumes the constructibility of a large class of curves (namely the curves we would nowadays call algebraic). It is likely that, in the author's view, the few examples of tracing devices proposed in the book are sufficiently clear instances of the ideal of geometric constructibility derived from his exactness norm. Descartes even remarks that it is superuous to add the description of other devices: "... Je pourrais mettre ici plusieurs autres moyens, pour tracer et concevoir des lignes courbes qui seraient de plus en plus composées par degrés à l'infini ..."

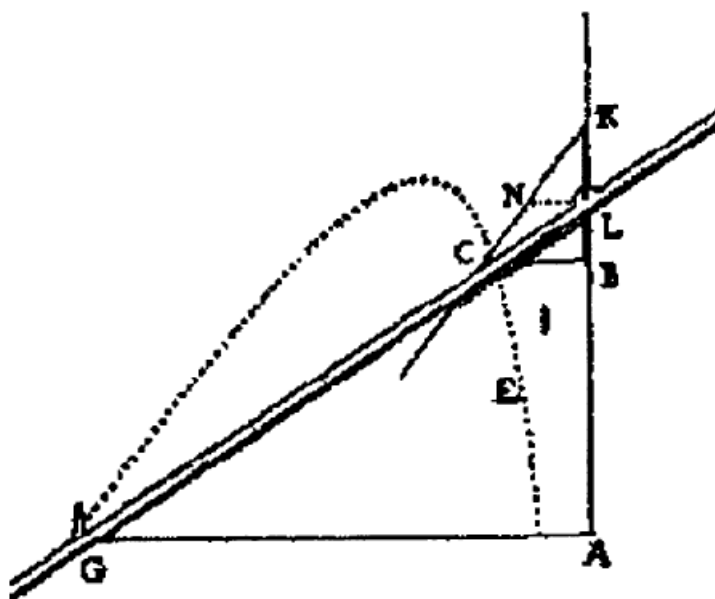

Figure 3.2.2: Descartes [1897-1913], vol. 6, p. 393.

Geometrical linkages, as they are conceived and presented in *La Géométrie*, meet a second condition, derivable from the previous one:⁹³ the compasses are conceived in such a way that, when they move, the trajectories of all their motions are totally constrained. In other words, the motions generated by geometrical linkages obey to purely kinematic movements, and the shape of the curves thus constructed are independent of the mechanical components of the movements, as the speed of the rotating joints and other physical interrelations.

A third property should be added to the previous ones. In order to expound this condition, let us return to the example depicted above, concerning the hyperbola-tracing linkage: after having proved that the curve traced by the device in fig. 3.2.1 is an hyperbola, Descartes described a similar instrument, in which he substituted a circle to the ruler KNC , and claimed that it would generate the "first conchoid of the ancients". This is the name by which it was classically known Nichomedes' conchoid, also described by Pappus in the *Collection* (see Commandinus [1588], fol. 56r.). Descartes does not illustrate the construction of the conchoid with any figure in *La Géométrie*, but one can evince from his verbal description a possible generation, as the one offered in fig. 3.2.1.

⁹³See especially Panza [2011], p. 81.

The curve FKN is generated by a linkage formed by the moving point F , extremity of the radius FE of a circle hinged to the pivoting ruler AE . When AE rotates, E slides along the vertical BD , and the circle of radius EF translates along the same direction. Since EF remains fixed, the curve traced by F will cut on the pivoting segment AE another segment of constant length (namely FE). This property endows the curve traced by F with the traditional symptoma of the conchoid described by Pappus, namely the "first conchoid".

The proof that the first conchoid of the ancients could be traced by a geometrical linkage, and therefore did qualify for geometry, stood as an important achievement in the backdrop of the classification into plane, solid, and linear curves offered by Pappus. By contriving to generate the conchoid through a geometric linkage, in fact, Descartes had managed to show that a curve traditionally ranged with the spiral and the quadratrix (genuinely mechanical, in Descartes' view), ought to be more properly grouped with the family of plane and solid curves. Even if the geometrical linkage devised by Descartes for the tracing of the conchoid embodies the traditional genesis of the curve as described by Pappus and by Eutocius, it brings forth, in virtue of its articulation, a structural similarity with the compass for the hyperbola, described above, and lastly grants that also the conchoid, being generated by reiterated ruler and compass, ought to be accepted as geometrical on a par with the conic sections or the circle.

If then a parabola - a curve that Descartes correctly assumed to be generated by a linkage, without however offering a construction in *La Géométrie* - is taken at the place of the ruler KNC , then the linkage will generate another curve QCD (in fig. 3.2.1. See Descartes [1897-1913], vol. 6, p. 477), more complicated, and unknown to ancient geometers. Even so, this curve will still be acceptable in geometry, since it complies with the exactness norm set by Descartes.

These examples show a peculiar characteristic of geometric linkages: as soon as a curve has been traced by a system of connected joints with one degree of freedom movement, it can become itself a component of the system, and thus trace other new curves, which in their turn can become parts of more articulated devices.

As Descartes suggests, the compositional nature of linkages induces a tower of devices with increasing complexity (the complexity of a device can be measured by the number of subdevices employed for generating each component) at whose basis stand ruler and

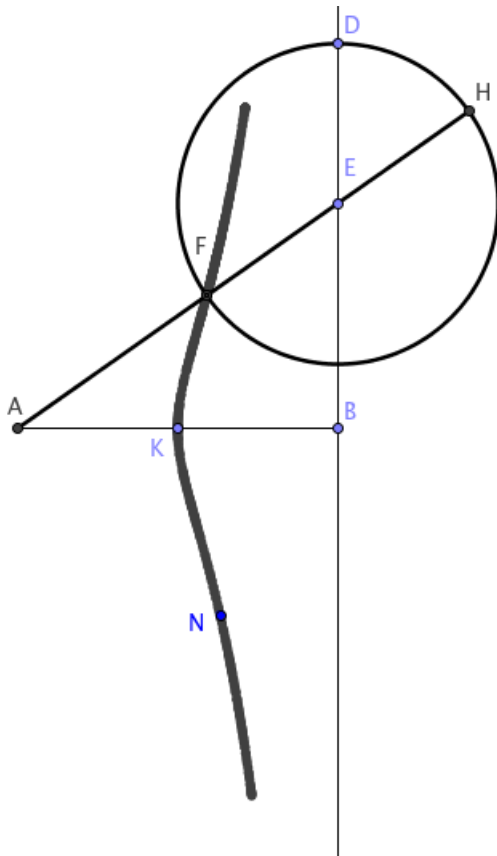

Figure 3.2.3: Descartes' conchoid.

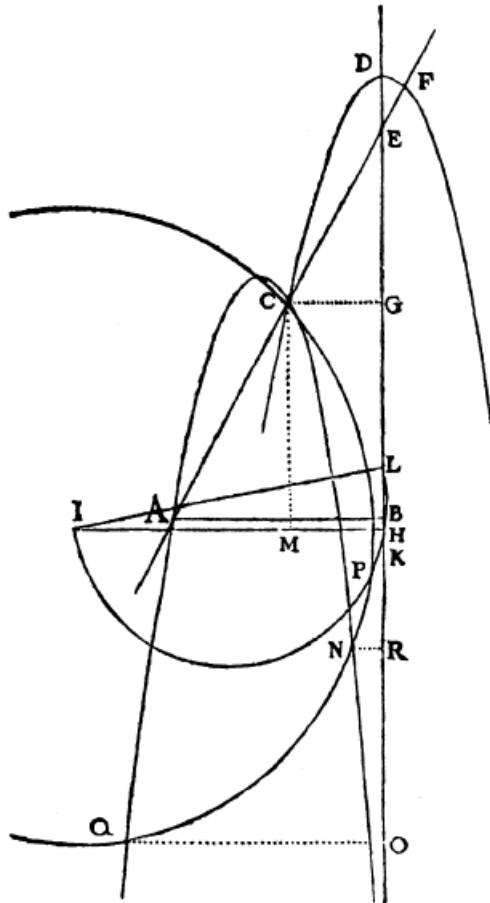

Figure 3.2.4: Descartes [1897-1913], vol. 6, p. 477.

compass, taken as elementary linkages for tracing straight lines and circles, which by iterative constructions can produce all other admissible curves.⁹⁴

By licensing the construction of the class of curve-tracing linkages, endowed with the properties spelled out above, Descartes' exactness norm can extend the clauses of constructibility fixed by Euclid's constructive postulates, in order to enrich the domain of legitimate, geometrical curves. As I will discuss in the next section, this extension warrants the possibility of supplementing any expression in the formalism of the algebra of segments with a construction, thus warranting the determinative character of Descartes' algebra of segments.

3.2.2 Early instances of geometrical linkages

An interesting question to be raised, as an *addendum* to the previous discussion, is whether there is a way to reconstruct the historical development which brought Descartes to the systematic characterization of geometrical curves offered in *La Géométrie*. In the already quoted passage from the 1619 letter to Beekman, we read in fact that Descartes envisaged a class of problems solvable by curves, raising from a unique motion and traceable by "new compasses" (*novos circinos*) as certain and geometrical as the common compass.

By spelling out the property of unicity of motion as early as 1619, in his letter to Beekman, Descartes seems to have insightfully anticipated one of the relevant properties we can ascribed to geometric linkages on the ground of their presentation in *La Géométrie*, namely the property of defining totally constrained trajectories, in which a principal motion can be singled out. We can thus wonder whether the tracing devices discussed in the *Cogitationes* incorporated this constraint, and whether, more generally, these devices can be considered as primitive instances of geometric linkages.

Leaving aside the case of the mesolabe compass, of which we can only have a conjectural, although plausible, reconstruction, I would like to consider the case of the trisector. This instrument, as examined above, is formed by a system of rigid, interconnected rulers, to which new rulers can be added so as to trace more complicated curves. Is this description sufficient in order to consider the trisector a linkage, on a par with the proportions compass and the other instruments presented in *La Géométrie*?

⁹⁴Descartes [1897-1913], vol. 6, p. 394-395.

As remarked by Panza (Panza [2011], p. 86), the trisector can be certainly considered a geometric linkage, provided it is constructed in such a way that the principal motion is identified with the rotation of the arm AC (I refer to fig. 3.0.2 above). This can be done if we can imagine the trisector to be constructed starting from a given segment AB , to which we join at A a segment AC forming with AB an arbitrary angle. Then a segment AF of arbitrary length is marked on AB , and the rest of the construction can be then easily completed, in an elementary way, by multiplying the angle CAB . In this way, the principal motion will be the rotation of the ruler AC around A , and the curve will be traced by point R . On the contrary, this compass cannot be built as a geometric linkage starting from the given segments AT and AB . In this case, in fact, AU and AC would be then constructible provided we already knew how to trisect the angle TAB (which would obviously beg the question), or through a process of adjustment and deformation of the arms, in order to contrive the connecting joints to have equal length in the final configuration. Such a contrivance would introduce a physical component in the functioning of the trisector: through the inclusion of forces, this instrument would thus be reduced to a physical device, and therefore to something remarkably different from a geometric linkage.⁹⁵

In the text of the *Cogitationes*, the principal motion of the ruler AC , a property which crucially characterizes the trisector as a geometrical linkage, is not emphasized. Descartes does not say in fact how the compass is constructed, but tells us only that the rulers are rigidly connected ("but one be unable to be augmented or diminished without the others' being moved") and the instrument can be opened by rotating segment AT (I refer, in particular, to fig. 3.0.2) which drags in its turn the other connected lines AU and AC (ac and ad in the original). Descartes singles out the correct point which generates the curve.⁹⁶ On the ground of this text, it seems that Descartes had understood some of the characteristics he would later attribute to linkages, but it is not clear whether he was aware of all the conditions to be imposed on a trisector, in particular, in order to consider this instrument a geometric linkage, on a par with those discussed in *La Géométrie*, and not as a physical device instead.

In conclusion, even if Descartes had already emphasized, in the early 20s, the importance of the instrumental generation of curves as a means for extending Euclid's constructive

⁹⁵See Panza [2011], p. 86. The distinction between the geometric nature of cartesian linkages versus the physical nature of other devices will be discussed again in the next chapter.

⁹⁶"Elevo lineam ba in partem b , quae secum trahit lineam ac & ad ..." (Descartes [1897-1913], vol. 10, p. 241).

clauses, he probably lacked a precise concept of geometric linkage back then. Only in the subsequent years, his answers to the questions about which family of constructing instruments is admissible beyond ruler and compass, and which relevant properties should such an admissible instrument possess became precise, and eventually reached their definitive form in *La Géométrie*.

3.2.3 The determinative character of cartesian algebra

All curves acceptable in Descartes' geometry can legitimately enter in the synthetic part of the problem solving procedure, allowing the construction of any polynomial equation with finite arbitrary degree. This conclusion rests on one of the groundbreaking insights which *La Géométrie* has brought to mathematicians: the construction of a curve by a geometrical linkage implies the possibility of exhibiting all points of the curve by an algebraic equation in two unknowns of the form: $P(x; y) = 0$. The entailment from constructability to algebraic expressability is conceded by Descartes, as the following passage explains:

... tous les points, de celles [of the curves] qu'on peut nommer geometriques, c'est a dire qui tombent sur quelque mesure précise et exacte, ont necessairement quelque rapport a tous les points d'une ligne droite, qui peut estre exprimé par quelque equation, en tous par une mesme.⁹⁷

As an example, Descartes determines the nature the curve GCE constructed by one of the geometric linkages (*cf.* figure 3.2), by finding the equation satisfied by all the points belonging to the curve. Descartes considers another point A on the straight line AB . From a point C , arbitrarily chosen on the curve, a straight line is drawn to AB at a given angle: the segments CB and BA , both unknown ("quantités indéterminées", Descartes [1897-1913], vol. 6, p. 394), are named by Descartes with the letters y and x . Following the problem-solving strategy deployed in Book I, Descartes names the other relevant magnitudes: $GA = a$, NL , parallel to CB , will be called c and $KL = b$. Working then on the elementary relations between similar triangles KNL and KCB , the relation between segments $CB = y$ and $CA = x$ can be finally expressed as an equation of the form: $F(x, y) = 0$, namely:

$$y^2 - cy + \frac{cx}{b}y - ay + ac = 0 \quad (3.2.1)$$

⁹⁷Descartes [1897-1913], p. 392.

Since point C has been chosen arbitrarily, Descartes can conclude, by generalization, that all the points belonging to the curve constructed with the geometric linkage described above satisfy equation 3.2.1. From this equation - Descartes claims, without explanations - we know that the curve is an hyperbola.⁹⁸

The correctness of Descartes' conclusion can be verified by proving that equation 3.2.1 expresses a geometric property which characterizes univocally an hyperbola. Following the suggestion advanced by Van Schooten in his commentary to *La Géométrie*, it can be shown, in fact, that the equation 3.2.1 implies the following geometric equality:

$$R(IC, BC) = R(DA, EA)$$

Namely, the rectangle with sides IC and BC is equal to the rectangle with sides DA and EA . Relying on proposition 10 of the second Book of Apollonius' *Conica*, we recognize that this equality characterizes indeed the curve GCE as an hyperbola whose asymptotes are FA and FD , which confirms Descartes' claim.⁹⁹

A more detailed proof can be found in Van Schooten's Commentary (see in particular, Descartes [1659-1661], p. 170-171), which I will follow hereinafter. Hence, let us complete Descartes' original construction, as shown in fig. 3.2.3:¹⁰⁰ AG is extended to point D , such that $DG = EA = NL$, and let a parallel to CK be traced from point D , which meets in a point K the segment AB extended.

Having worked out these auxiliary constructions, let us rewrite equation 3.2.1 as:

$$(a + c - \frac{cx}{b} - y)y = ac$$

⁹⁸Descartes [1897-1913], vol. 6, p. 394.

⁹⁹The reference to Apollonius' *Conica* is made by Van Schooten in Descartes [1659-1661], p. 172.

¹⁰⁰The figure reproduces Van Schooten's diagram in his commentary to the latin edition of *La Géométrie* (Descartes [1659-1661], p. 171).

By setting: $AG = DA = a$, $KL = b$, $NL = EA = c$, $DH = AB = x$, $BC = y$, it can be proved that: $a + c - \frac{cx}{b} - y = IC$, and therefore:

$$IC \times BC = DA \times EA$$

Since DF and CK are parallel, angles DFA and CKA are equal. Let us then produce BC , so that it meets DF in a point I , and raise from D the parallel to AF , meeting the line BC extended in a point H . The triangles: DHI , KLN , and FAD are thus similar (indeed it can be easily proved that all their angles are equal), and the following proportion holds:

$$KL : LN = DH : HI$$

As an immediate consequence from the proportion above, we have that: $HI = \frac{cx}{b}$. From fig. 3.2.3, the following equality can be deduced: $HB - HI = IB = DA - HI$. Since $HI = \frac{cx}{b}$, $DA = a + c$, $IB = a + c - \frac{cx}{b}$,¹⁰¹ the segment IC can be eventually determined as: $IC = IB - BC = a + c - \frac{cx}{b} - y$. By consequence, from the equation: $(a + c - \frac{cx}{b} - y)y = ac$ we can infer: $IC \times BC = DA \times EA$.

I point out that Van Schooten refers to a property satisfied by all points lying on an hyperbola, proved by Apollonius in the *Conics*, Book II, prop. 12, and singled out also by Proclus in connection with a discussion about solid loci.¹⁰² This reference may not be casual, but indicative of the fact that an equation was conceived, by Descartes and by his readers, as incorporating not only the symptoms of curves known since Antiquity, but also their properties (and theoretically all the properties) by which a curve can be characterized as a locus. It is therefore understandable why, in order to verify that the curve traced by the linkage in fig. 3.2.1, is an hyperbola, Van Schooten relied on a property asserted by a well-known solid locus theorem.

In an important article on the conceptual origins of cartesian geometry, A. G. Molland has pointed out how Descartes' algebra of segments can enrich the possibilities of denoting

¹⁰¹In fact, we have that: $DA = AG + DG$, and by hypothesis it is also: $DG = NL = c$. Hence $DA = a + c$.

¹⁰²Proclus [1992], p. 311; see 2, sec. 2.2.1.

a curve, by allowing the reference either to its equation, or to its geometrical description via a suitable linkage, and referred to these two modes for describing a curve in terms of "specifications". More precisely, he observed that the construction of a curve by one of the cartesian linkages is an instance of a "specification by genesis", while the way of describing a curve by giving its equation in x and y is a case of 'specification by property': "An equation in terms of x and y - Molland observes - could determine the curve, by specifying a property all its points had to obey (...) this has close similarities to such ancient procedures as Apollonius' establishment of *symptomata*".¹⁰³

The similarity between the meaning and role of *symptomata* in ancient geometry and the role of equations as specifications of curves, in Descartes' geometry, is indeed manifest. I have already remarked (chapter 2, p.68) how the symptoms of a curves can be understood in terms of relations expressing the fundamental properties of the curve under examination. More precisely, for the case of the conic sections: "the symptoma refers to a single arbitrary point on a given curve by relating a single square to a single rectangle (...) Thus, once a conic section is given, the *symptoma* gives an *immediate* criterion for a point to be on that conic section".¹⁰⁴ Analogously, the equation 3.2.1 can be understood as referring to an arbitrary point belonging to the curve drawn by a geometric linkage, by relating its distances from a couple of given segments, and by giving, in this way, a criterion in order to recognize the curve thus drawn as a particular conic section, namely an hyperbola. But, as the example of the hyperbola discussed by Van Schooten shows, an equation associated to a geometric curve incorporates not merely the information on the *symptomata*, but theoretically all information on the properties of a curve. Descartes is explicit on this: "Pour trouver toutes les propriétés des lignes courbes - he subtiles a paragraph of *La Géométrie* - il suffit de sçavoir le rapport qu'ont tous leurs points a ceux des lignes droites", and explains:

Or, de cela seul qu'on sçait le rapport qu'ont tous les poins d'une ligne courbe a tous ceux d'une ligne droite, en la façon que j'ay expliquée, il est aysé de trouver aussy le rapport qu'ils ont a tous les autres poins et lignes données &, en suite, de connoistre les diametres, les assieux, les centres, & autres lignes ou poins a qui chasque ligne courbe aura quelque plus particulier, ou plus simple, qu'aux autres. . .¹⁰⁵

¹⁰³Molland [1976], p. 38.

¹⁰⁴Michael N. Fried [2001], p. 88.

¹⁰⁵Descartes [1897-1913], vol. 6, p. 412-413.

According to Molland, moreover: "Descartes held the possibility of representing a curve by an equation (specification by property)" to be equivalent to its "being constructible in terms of the determinate motion criterion (specification by genesis)".¹⁰⁶ This equivalence is only suggested but not proved by Descartes. If, on one hand, constructability by geometric linkages implies the representability of curves by equations in virtue of the very constitution of the licensed linkages, on the other Descartes seems confident that any algebraic curve can be constructed by a legitimate tracing device, although he does not bother giving a proof of this claim.¹⁰⁷

If this equivalence is uncontrovertible from the mathematical viewpoint (a curve constructed by a geometrical linkage can be specified via an algebraic equation, and conversely, a curve corresponding to a given algebraic equation can be constructed by a suitable geometric linkage) the same may not be said from an epistemic viewpoint. In other words, specification by genesis (in terms of geometric constructions) and specification by property do not seem to stand on a par for Descartes when it comes to secure the knowledge of a geometrical object, in this case a curves.

On the contrary, I surmise that in the context of Descartes' geometry, the specification by genesis of a curve still exerted a primary role in securing epistemic access to it. The first evidence in order to support this claim consists in the plain observation that curves are dealt with, in *La Géométrie*, notwithstanding their algebraic description: for instance, Descartes discussed several curves without giving their equation or barely mentioning them.¹⁰⁸

A second evidence can be retrieved from the arguments given above, concerning the acceptability of curves. Descartes often combined words like "tracer" with "connoistre", "concevoir", in such a way that that legitimate procedures for tracing curves supposedly bear a standing to warrant epistemic access to the produced objects.¹⁰⁹ Van Schooten's later commentary was still more explicit on the point. Thus, in the prefatory words

¹⁰⁶Molland [1976], p. 38.

¹⁰⁷It is held that such a conjecture was proved by Kempe, in a famous paper from 1876 (Kempe [1876]) in which he lay down the important result that any algebraic curve was traceable by a series of interconnected moving joints called "linkages". However: "we may conclude from the intricacy and the late date of Kempe's method that a general tracing method for algebraic curves was not within Descartes' reach, let alone one which satisfied his further criteria" (Bos [2001], p. 405).

¹⁰⁸As it is the case of the description of the optical ovals. See H. Bos. The structure of descartes' geometry, in Belgioioso and Costabel [1990], p. 54.

¹⁰⁹Bos [1981], p. 308.

to the second book he emphasized the role of the construction by geometrical linkages, effectuated in respect of Descartes' exactness norm, as the mode of knowing (*modus cognoscendi*) a curve:

Secundus liber agit de lineis curvis, earumque naturam explicat, docendo, quanam illae sint, quae in geometriam recipere oportet, quaeque geometricae appellandae sunt, itemque quo pacto possint cognosci. Modus autem eas cognoscendi in eo consistit, quod describi possint per motum aliquem continuum, vel per plures eiusmodi motus, quorum posteriores regantur a prioribus.¹¹⁰

Hence, the construction of a curve according to the standards in force within Descartes' geometry, namely, its 'specification by genesis' secured the givenness of the curve itself in geometry, and therefore the very possibility of its knowledge.¹¹¹

Moreover, the representability of curves through equations, stands as the conclusive step in order to endow cartesian algebra of segments with its determinative character. In fact, through the possibility of associating acceptable curves to finite polynomial equations, Descartes managed to work out a procedure in order to construct any (real) root of a given polynomial equation in a finite arbitrary degree, through the intersection of a pair of geometric curves. The specification of curves through algebraic equations played an essential role in constituting a criterion for the ordering of curves, as I will explicate in the following chapter.

¹¹⁰Descartes [1659-1661], p. 167: "The second book [of *La Géométrie*] concerns curve lines, explains their nature, teaching which lines they are, which it necessary to receive in geometry, and which are to be called geometrical, and likewise how they can be known. And the way of knowing them (*modus eas cognoscendi*) consists in this, that they can be described by a continuous motion, or by several motions of this kind, of which the subsequent ones are governed by the preceding ones".

¹¹¹In this sense, we are allowed to talk about Descartes' 'constructivism', as suggested in Serfati and Bitbol [2002].

Chapter 4

Simplicity in Descartes' geometry

4.1 Introduction

As anticipated in chapter 3, Descartes lays down precise methodological guidelines, in *La Géométrie* (1637), in order to solve a problem in the most appropriate way. These rules involve a clearcut restriction in the domain of acceptable curves to those constructible by geometric linkages, with the exclusion of few, 'mechanical' curves.

But the demarcation between mechanical and geometrical curves was not sufficient, from Descartes' viewpoint, in order to solve a problem geometrically. In fact Descartes explicitly recommended to use the 'simplest' solving means for a problem at hand. For the case of problems reducible to quadratic equations, the choice of the simplest means was uncontroversial. Descartes had given, in Book I, a method for the construction of quadratic equations by means of circles and straight lines, therefore it was natural to consider these curves as the simplest available ones. The choice became harder for the case of problems whose analysis had led to higher equations. What were the 'simplest' curves, in these cases?

Although the notion of the maximal simplicity for the solution of a problem had probably been accepted as a *desideratum* since antiquity,¹ Descartes proposed the first attempt (to my knowledge) in order to disambiguate the concept of simplicity in mathematics, more particularly in geometry:

Encore que toutes les lignes courbes, qui peuvent estre descrites par quelque mouvement regulier, doivent estre recües en la Geometrie, ce n'est pas a dire

¹Van der Waerden [1961], p. 263, and chapter 2 of this study, in particular section 2.2.

qu'il soit permis de se servir indifferemment de la premiere qui se rencontre, pour la construction de chaque Probleme: mais il faut avoir soin de choisir toujours la plus simple, par laquelle il soit possible de le resoudre. Et meme il est a remarquer, que par les plus simples on ne doit pas seulement entendre celles, qui peuvent le plus aysement estre descrites, ny celles qui rendent la construction ou la demonstration du Probleme proposé plus facile, mais principalement celles, qui sont du plus simple genres qui puisse servir a determiner la Quantité qui est cherchée.²

I interpret Descartes' passage as offering an accurate distinction into two main types of simplicity:

- Easiness: A curve \mathcal{C} is simpler than a curve \mathcal{D} with respect to a given problem, if both \mathcal{C} and \mathcal{D} solve the problem at hand, but curve \mathcal{C} can be described in a way that is 'easier', namely more transparent to understanding (I will discuss this concept in more detail in the sequel) than the description of \mathcal{D} .
- Dimensional simplicity. A curve \mathcal{C} is simpler than a curve \mathcal{D} if the first curve belongs to a class inferior to the class of the second curve, according to a numerical order of classes established in *La Géométrie*. Since the fact that a curve belongs to a given kind is established by its equation, it can be said that algebraic considerations ultimately guide the choice of the simplest curve in Descartes' practice.

In Descartes' view, only the second type must be taken into account in problem solving. This distinction has a strong normative aspect which constrains so much the problem-solving strategy that any violation is explicitly considered an error in geometry ("une faute", as written in Descartes [1897-1913], vol. 6, p. 443).

More precisely, Descartes imposes, in *La Géométrie*, two constraints in order to avoid such errors in geometry. Firstly, one must refrain from trying to solve a problem by too simple means with respect to the class to which the problem belongs, and secondly, one must also refrain from using too complex methods with respect to the class of the problem.³

²Descartes [1897-1913], vol. 6, p. 370.

³Descartes [1897-1913], vol. 6, p. 444.

However, not only the preference for dimensional simplicity is not justified in *La Géométrie*, but it can also be questioned whether it is the most rational or obvious choice, when it comes to decide the best methods in order to construct a problem. In this chapter, I will provide an argument in order to justify the motivations behind the choice of dimensional simplicity, in the light of Descartes' attempt to find a rational systematization of problems and solving methods which could improve the ancient ones. This justification will also offer the context in which the first attempts to prove some impossibility results of extratheoretical kind (namely, the impossibility of solving solid problems by ruler and compass) occurred.

4.2 Simplicity in early modern geometry

Although the previously quoted passage from Book III of *La Géométrie*, in which Descartes lays down the methodological rules for problem-solving, does not contain any explicit references to Pappus, there is little doubt that the homogeneity requirement explicated in Book III and IV of the *Mathematical Collection* (Cf. Ch. 2.) was envisaged as a direct reference in Descartes' discussion about the simplicity requirement. In his latin commentary of Descartes' *Géométrie*, van Schooten even paraphrased the requirement to solve a problem by the simplest curves, employing a terminology evidently borrowed from Commandinus' latin version of the *Collection*:

Ubi observandum est quod, cum peccatum sit non leve apud Geometras, Problema planum construere per Conica aut Linearia, hoc est, ipsum per improprium solvitur genus, ita quoque sit cavendum, ne in constructionem ejus adhibeamus lineam aliquam curvam, quae magis sit composita, quam ipsius natura admittit.⁴

The closeness to Pappus' statement can be better appreciated considering how Commandinus rendered Pappus' proposition 30 of Book IV:

Videtur autem quodammodo peccatum non parum esse apud Geometras, cum problema plano per conica, vel linearia ab aliquo invenitur, et ut summatum (summatim?) dicam, cum ex improprio solvitur genere . . .⁵

⁴Descartes [1659-1661], 277: "Where it must be observed that, as it is not a small sin by the geometers to construct a plane problem with conics or linear curves, namely, to solve it by a non kindred kind, so it must be paid attention not to employ in its construction a curve which is more composed than conceded by its nature".

⁵Commandinus [1588], fol. 61r: "It seems a somehow non small sin, among geometers, when someone

There is no doubt, therefore, that Descartes's methodological guidelines for solving problems in the 'simplest' way were deeply indebted (or at least were considered so by Descartes' contemporaries and fellows) to what has been called, in the first chapter of this study: "Pappus' homogeneity requirement".

As we can infer from the frequent references in the contemporary literature, Pappus' constraint was often interpreted by early-modern geometers as a constraint on the simplicity of solutions: it was considered an error, or in any case an illegitimate move to solve a problem with means more complicated than necessary.

An example of reading of Pappus' norm in terms of simplicity is offered by Marin Mersenne, in his *Harmonie Universelle* (1636), where curves are classified into plane, solid and linear, probably on the grounds of their constructional simplicity. Indeed, circles and straight lines (plane curves), whose construction - points out Mersenne - is postulated by Euclid at the beginning of the *Elements*, are also the simplest geometrical curves. Conic sections follow plane curves in an ordering of decreasing simplicity, since they are produced by cutting a cone, in its turn generated by the rotation of a straight line around the circumference of a circle. Finally, Mersenne groups those curves traditionally excluded from the other two classes: conchoids, spirals, quadratrices, whose description is barely judged "almost impossible".⁶

Mersenne also reformulated Pappus' requirement, according to the virtue of simplicity:

Il semble raisonnable que tout Probleme qui peut estre resolu par les lieux plans, soit resolu par les lieux plans, et que celuy qui ne pouvant estre resolu par les lieux plans seuls, le peut estre par les lieux solides seuls, ou meslez avec les lieux plans: en fin quand un Probleme est de telle nature qu'il ne peut

solves a problem of plane kind by means of conics, or linear curves, and, to speak generally, when it is solved by a non-kindred kind (*improprio genere*)".

⁶The passage in its entirety is reproduced here: "Or comme les anciens, au rapport de Pappus, avaient estimés que c'était une grande faute de resoudre par les lieux solides ou lineaires, un problème, qui de sa nature pouvoit estre resolu par les seuls lieux plans, j'estime semblablement que la faute n'est pas moindre, de resoudre par des lieux lineaires, ou par des mouvements impliqués, ou par des descriptions è taton, un problème que de sa nature peut estre resolu par des lieux solides. Car puis qu'entre les lieux l'ordre est tel, que ceux que nous appelons plans sont les plus simples, à sçavoir la ligne droite, et la circonférence du cercle, la description desquelles Euclide demande luy estre accordée au commencement de les *Elements*: apres lesquels suivent les lieux solides, qui prennent leur origine de la section d'une superficie conique, engendrée d'une ligne droite et de la circonference d'un cercle (...) qui sont suivis des lieux que l'on appelle lineaires, engendrez le plus souvent par deux mouvement impliquez, comme les Choncoïdes, les Spirales, les Quadratrices et une infinité d'autres, dont la description est pour l'ordinaire presque impossible... *Mersenne [1636]*, vol. 2, p. 407.

estre resolu par les lieux plans ou solides, alors il est permis de le resoudre par les lieux lineaires seuls, ou meslez avec les lieux plans, et solides: de sorte toutefois que l'on se serve le plus que l'on pourra des lieux plans, et le moins que l'on pourra des autres; et qu'une construction soit plus estimée, en laquelle il n'entrera qu'un lieu solide, le reste estant plan, que celle en laquelle entreront deux lieux solides, puis qu'à l'imitation de la nature, nous devons tout faire par les moyens les plus simples.⁷

According to Mersenne, therefore, simplicity is rooted in the way nature operates, so that a violation in the simplicity of the solution would result in a misunderstanding of its nature.

An echo of this thesis is to be found in Fermat's *Dissertatio Tripartita*, written after december 1637:⁸

Puriorem certe Geometriam offendit qui ad solutionem cujusvis problematis curvas compositas nimis et graduum elatiorum assumit, omissis propriis et simplicioribus, quum jam saepe et a Pappo et a recentioribus determinatum sit non leve in Geometria peccatum esse quando problema ex improprio solvitur genere.⁹

Fermat's direct reference was Descartes, who offered a similar view in his *Géométrie* of 1637.

We can therefore conclude that a reading of Pappus' classification of problems presented in Book IV, in terms of the simplicity of their solving curves, was current, or at any rate not new during the first half of the XVIIth century, and that such a reading had influence also Descartes' understanding of Pappus' requirement. Less clear were the directives about how simplicity ought to be interpreted. In this setting, Descartes had certainly the merit to propose a clearcut interpretation of simplicity as a fundamental criterion for the classification of curves, which represented a touchstone for several generations of future geometers.

⁷*ibid.*

⁸Mahoney [1973], p. 130.

⁹"Certainly it is an offense against the more pure geometry if one assumes too complicated curves of higher degree for the solution of some problem, rather than taking the simpler and more proper ones, because, as Pappus, and recent mathematicians as well, have often declared, in geometry it is a considerable error to solve a problem by means that are not proper to it"(in Arana [2003], p. 256).

4.3 Classifications of curves and problems

4.3.1 Ancient and modern classifications

In Descartes' geometry, the concept of dimensional simplicity is directly dependent on a classification of curves into kinds ("*genres*"), articulated in Book II and III of *La Géométrie*, and ultimately on the degree of their associated equations.¹⁰ In this section, I would like to evaluate it with respect to the ancient classificatory scheme proposed by Pappus.

At the beginning of Book II of *La Géométrie*, Descartes praised the ancients for having introduced a distinction between plane, solid and linear problems. I stress that Descartes gave a positive assessment of this distinction, that he presumably had learned from Pappus. This is confirmed by the fact that Descartes did not reject it but incorporated the ancient classification into his own classificatory scheme: as I will explicate more precisely below, problems are sorted out, in *La Géométrie*, into classes on the ground of the nature of curves entering their solution.

Descartes remained however critical towards two aspects of the classifications of the ancients. Firstly, he argued, ancient geometers had allegedly proposed a misgiven distinction between geometrical and mechanical curves; secondly, they lacked a more fine-grained distinction into classes of geometric curves beyond the conic sections.

But Descartes might have perceived another quandary with respect to the ancients' grouping of problems and curves. As I have commented before (in particular, in chapter 2 of this study), in Books III and IV of Pappus' *Collection*, we encounter a classification of construction problems based on the means needed for their solutions. This classification entailed a major logical difficulty: one problem could in principle be solved by methods and curves of different kinds in such a way that, except for certain cases, deciding the appropriate level of a construction problem may turn out to be a complex, and perhaps undoable task in classic geometric reasoning.

I shall thus argue, in what follows, that Descartes' reform of the classifications of the ancients, obtained through the substantial contribution of algebra, could represent an advance over ancient models because it offered a more reliable method in order to establish the nature of a proposed problem.

¹⁰See, for instance: Sasaki [2003] (p. 222ff.) and in Bos [2001], p. 355ff.

4.3.2 A classification of curves

Descartes elaborated in book II of *La Géométrie* a classification of curves into successive classes ("genres") determined by the degree of the associated equations:

... lorsque cette equation ne monte que iusques au rectangle de deux quantités indeterminées, ou bien au carré d'une mesme, la ligne courbe est du premier et plus simple genre, dans lequel il n'y a que le cercle, la parabole, l'hyperbole et l'ellipse qui soient comprises. Mais que, lorsque l'equation monte iusques a la trois ou quatrieme dimension des deux ou de l'une des deux quantités indeterminées: car il en faut deux pour expliquer icy le rapport d'un point a un autre: elle est du second. Et que, lorsque l'equation monte jusqu'a la cinq ou sixiesme dimension, elle est du troisieme: et ainsy des autres a l'infini.¹¹

Descartes explains that a curve is more complex ("composé") than another one when it belongs to a kind higher than the kind of the second curve. This ordering of curves into kinds proceeds, in *La Géométrie*, in a pairwise manner: the first class (genre) includes curves associated with equations in degrees 1 and 2 (the degree of an equation is to be understood in the modern sense, namely, it concerns both unknowns taken together. In this way, the monomial ' xy ' will have degree 2), that is straight lines, circles and the other conic sections; the second class includes curves associated with equations in degrees 3 and 4, like the cartesian parabola introduced in book III of *La Géométrie*;¹² the third class will include curves expressible with equations in degree 5 and 6, and so on, for any couple of equations of degree $2n, 2n - 1$.¹³

The motivations of this pairwise grouping are thus explained:

Au reste je mets les lignes courbes qui font monter cette Equation jusqu'au quarré du quarré au mesme genre que celles qui ne la font monter que iusques au cube. & celles dont l'equation monte au quarré du cube, au mesme genre que celle dont elle ne monte qu'au sursolide, & ainsi des autres. Dont la raison est, qu'il y a reigle generale pour reduire au cube toutes ls difficultés

¹¹Descartes [1897-1913], vol. 6, p. 392-393.

¹²Descartes [1897-1913], vol. 6, p. 481ff.

¹³I remark that Descartes' classification does not take into account the case of degenerate curves of any degree.

qui vont au quarré du quarré, & au sursolide toutes celles qui vont au quarré de cube, de façon qu'on ne les doit point estimer plus composées.¹⁴

Even after this explanation, the rationale of Descartes' pairwise classification is not obvious. It might have been based on purely algebraic concerns, as Bos [2001] suggests. Descartes might have thought, for instance, to import into the structure of his classification of curves two important algebraic facts known and currently applied by the mid XVIIth century: on one hand the fact that equations of 4th degree can be reduced to equations of 3rd degree, and on the other, the fact that third degree equations withstood all attempts to be reduced to quadratic equations.¹⁵ On this ground, it would make sense to range together in the same class problems described by quartic and cubic equations, for instance, and in contrast to range curves described by cubic and quadratic equations in different classes, respectively.

This could have been the starting point taken by Descartes in order to generalize the pairwise classification holding for curves, until the 4th degree, to successive couples of curves, associated to equations of degree $2n$ and $2n - 1$, respectively (with $n > 2$). This interpretation is endorsed by Fermat, for instance, who noted:

Similiter quoque cubocubicam aequationem ad quadratocubicam sive aequationem sexti gradus ad equationem quinti deprimet, licet aliquanto difficilior, Vietaeus aut Cartesianus Analysta. Ex eo autem quod in praedictis casibus, in quibus una tantum ignota quantitas invenitur, aequationes graduum parium ad aequationes graduum imparium proxime minorum deprimuntur, idem omnino contingere in aequationibus in quibus duae ignotae quantitates reperiuntur confidenter pronuntiavit Cartesius pagina 323 Geometriae lingua gallica a ipso conscriptae.¹⁶

¹⁴Descartes [1897-1913], vol. 6, p. 395-396.

¹⁵The notion of reducibility here considered is a technique which obtains of equations of the form $H(x) = U(V(x))$. In order to reduce such equations, it is necessary at first to solve $U(y) = 0$, then, inserting the value for y , to construct $y = V(x)$. Descartes followed this technique in solving quartic equations: at first he transformed a 4th degree equation into a 6th degree one, and subsequently he transformed the latter into a third degree equation in x^2 . See Bos [1984], p. 342-343. 'Reducibility' is, in this context, a technical term employed to denote a particular algebraic process. As I will explain later on, it should be distinguished from another type of reducibility, obtained by factoring a given polynomial.

¹⁶As we read in Mahoney's translation: "In a similar manner, (though with somewhat more difficulty) the Vietian or Cartesian analyst will reduce a cubo-cubic equation to a quadrato-cubic, i.e an equation of the sixth to one of the fifth degree. And, because in the aforesaid cases, in which there is only one unknown quantity, equations of even degree can be reduced to the next lower odd degree, Descartes has confidently asserted on p. 323 of the French version of his geometry that exactly the same thing holds true of equations in which there are two unknown quantities" (Mahoney [1973]p. 134).

However, Descartes' commitment to such a strong and unproved conjecture in order to ground his classification of problems remains stunning, and grounded on outright false premisses. Indeed, his claim about reducibility could be proved only for $n = 2$, as Ferrari's and Viète's rules for solving quartic equations show, but there is no possible reduction of sextics to quintics, and, at any rate, no argument (even flawed) was advanced by Descartes to warrant this fact.¹⁷

Anyhow, Descartes' choice to privilege a criterion of classification based on equations remains a noteworthy fact. Since an equation incorporated, according to Descartes' saying, all information about the properties of a curve, we shall conclude that Descartes' classification into kinds is primarily based on the 'specification of properties' of curves. This is a relevant difference with respect to Pappus' classification of curves, which depends on their genesis, or even from the classification of curves adopted by Descartes himself in his early writings.¹⁸

The ancients were certainly not ignorant of ways of characterizing curves by their properties. For instance, by solving locus-problems or proving locus-theorems, they were possibly able to endow supplementary properties to the curves they could construct and characterize via their symptoms. But I want to stress another point already emerged in this study: while ancient geometers lacked a systematic means in order to express *all* the properties of a curve, Descartes possessed, on the contrary, a compact symbolic notation

¹⁷But, as suggested especially by Freguglia (Freguglia [1999b], p. 173ff.) the mention of a "general rule in order to reduce to the cube all difficulties that go to the quadrato-quadratic (*quarré du quarré*)" might be also read as a reference to the fact that Descartes possessed a technique, detailed in Book III of *La Géométrie*, in order to construct both 4th and 3rd degree equations (in one unknown) by means of the same choice of curves, namely a parabola and a circle (I shall delve into an example in one of the next sections). As I have discussed in the previous chapter, an equation issued from the analysis of an indeterminate problem, thus an equation in the form: $F(x, y) = 0$, can be associated to a curve constructible point by point, according to Descartes' problem-solving protocol, by taking one of the two unknowns, i.e. y , and replace it by a letter denoting a known segment (i.e. the letter a), so that the resulting equation will be: $F(x, a) = 0$. So, if $F(x, y) = 0$ has degree 2, it can be pointwise constructed by ruler and compass; if $F(x, y) = 0$ has degree 3 or 4 (namely, if it is a cubic or a quartic), its points are constructible by intersections of a circle and a parabola, which is indeed the standard procedure adopted by Descartes, in Book III of *La Géométrie*. Likewise, Descartes constructed equations of degree 5 and 6 (in one unknown) by means of the same apparatus, and was confident that this pattern could be extended indefinitely. Might this be the rationale in the backdrop of Descartes' classification into genres of curves? This possibility cannot be ruled out, although it seems problematical. Let us suppose, for a moment, that it were the case. Then we would have a classification scheme for curves grounded on a technique for constructing equations, which in its turn depends on the choice of the simplest curves, as I will explicate in the next section. This amounts to saying that Descartes' technique for constructing equations depends itself on a classification of curves into kinds, so that it cannot ground that very classification.

¹⁸For instance, ch. 3, p. 104.

for this aim, since he could rely on equations.¹⁹

R. Rashed has underlined, in his Rashed [2005], the historical significance of the shift from classifying curves on the ground of their mode of generation to classifying curves on the ground of their properties, remarking:

C'est en effet un événement dans l'histoire des mathématiques lorsque le mode de génération de la courbe et sa formule président conjointement à sa classification. C'est d'abord pour les coniques qu'un tel événement se produit, au X siècle (...) puis pour les courbes algébriques avec Descartes.²⁰

According to Rashed, the criterion of classification adopted by Descartes was the culminating point of an evolution whose seeds can be found already in arabic mathematics. I will not discuss this thesis here, except for observing that Descartes' classification scheme, although being grounded on the 'specification by property' does not rule out the mode of generation of curves as a principle for ordering curves.

On the contrary, Descartes recognized the existence of a layer of complexity of curves not fully captured by the classification of curves into kinds. For instance, conic sections and the circle are all curves of the first class, according to the scheme presented in *La Géométrie*, although Descartes conceded that one could solve more problems using conic sections than by using solely circles and straight lines. Descartes agreed, as a consequence, that his classification into kinds of curves did not fully express, in itself, the 'power' of curves in problem solving. This property is portrayed, perhaps a bit vaguely in *La Géométrie*, with the following words:

mais il est a remarquer qu'entre les lignes de chaque genre, encore que la plupart soient esgalement composées, en sorte qu'elles peuvent servir a déterminer les mesmes points, & construire les mesmes Problemes, il y en a toutefois aussy quelques unes, qui sont plus simples, & qui n'ont pas tant d'estendue en leur puissance, comme entre celles du premier genre (...) le cercle, qui manifestement est plus simple, & entre celles du second genre il y a la Conchoide vulgaire (...) & il y en a encore quelques autres, qui bien

¹⁹See Descartes [1897-1913], vol. 6, p. 412, in particular the title of the paragraph: "Pour trouver toutes les propriétés des lignes courbes il suffit de sçavoir le rapport qu'ont tous leurs points a ceux des lignes droites". Cf. also Sasaki [2003], p. 220ff.

²⁰Rashed [2005]. p, 5.

qu'elles n'ayent pas tant d'estendue que la plus part de celles du mesme genre, ne peuvent toutefois estre mises dans le premier.²¹

With hindsight, we can recognize here a dim intuition of the notion of constructional complexity of curves, worked out in a fully-fledged form only in late XIXth and early XXth century.²² The distinction advanced by Descartes between curves that, within the same kind, have a less or more extended application in problem solving, remains grounded on a mix of qualitative considerations, either concerning the genesis of the curve itself, or the knowledge of its employment in solving problems, derived from the geometers' experience. For instance, Descartes was well conscious that ruler and compass (or, analogously, straight lines and circles) cannot solve problems that are solvable by the use of conic sections instead. On the other hand, Descartes noted that the circle is also generated in a simpler way than the hyperbola, for instance, which is a curve of the same class.²³ Analogously, the conchoid, being generated by a pivoting line that moves a circle will be simpler, from the point of view of its constitution, than a cartesian parabola, generated by a pivoting line and a moving parabola, although both curves belong to the same class (both constructions are analyzed in chapter 3, sec. 3.2.1 and sec. 3.2.1).

²¹Descartes [1897-1913], vol. 6, p. 396.

²²The possibility of associating analytic operations to geometric constructions in order to determine the constructional possibilities of the diverse instruments, or curves, offers also a criterion in order to judge the range of problems a given set of instruments or curves can solve. In this way, it is possible to define, in mathematically precise terms, the "constructional power" of a curve. This issue is discussed by Federigo Enriques in Enriques [1912], vol. 2, p. 583, for instance: "Since we can associate to any instrument (whose mode of employment has been fixed in advance) a body of solvable problems, the power of the instrument can be rightly appreciated with respect to the extension of this field. If two instruments, or groups of instruments, correspond to the same body, they must be regarded as *equivalent* ...". Enriques refers then to the problem of determining the constructional possibilities of several instruments, namely ruler and compass, ruler alone, and compass alone. A companion article, written by Castelnuovo, provides further insight into the question, from the viewpoint of the latest advances in the field of algebra and analytic geometry: "The examination of the problems solvable by ruler and compass, and more generally by other instruments, involves two stages, one concerning analytic geometry, the other concerning algebra or analysis. It must be examined which effects are produced, upon a geometrical figure, by a construction performed through a given instrument. And because, by the means of analytic geometry, any geometric operation corresponds to an analytic operation, one must search for the analytic operation equivalent to a construction performed by some instruments (a ruler, a compass ...)" ((Enriques [1912], vol. 2, p. 314). Underscoring this programme, we find several concepts foreign to the conceptual framework of Descartes' geometry. It is the case, for instance, of the idea of an analytic geometry over the reals, that cannot be found in force within Descartes' geometry, where algebra is but a compact notation for expressing proportions between geometric quantities, as seen in the previous chapter.

²³*Cf.* Descartes [1897-1913], vol. 6, p. 395:.

It can be inferred from the above examples that Descartes did not dismiss, alongside with a classification of curves based on degree, a classification of curves based on the complexity of their generation. Descartes indeed set up, in Book II of *La Géométrie*, a correspondence, never elaborated any further though, between the complexity of the linkages which construct geometric curves and the kinds to which the constructed curves belong. This correspondence can work, in principle, on the ground of the compositional nature of linkages: in brief, the fact that a curve traced by some linkage can enter in the composition of a new linkage makes the latter more complex.

On the ground of this intuition, Descartes observed that if one removes, from the linkage employed in order to construct a curve of the first kind (e.g., an hyperbola), one of its components (for instance, a ruler) and he replaces this ruler with a curve of the first kind (for instance, a parabola) a curve of the next kind can be obtained, like the cartesian parabola described in chapter 3 (p. 143). Descartes extrapolated from this correct example an incorrect generalization it to successive kinds of curves:

Mais si, au lieu d'une de ces lignes courbes du premier genre, c'est en une du second genre qui termine le plan *CNKL* on en décrira, par son moyen, une du troisieme: ou, si c'est une du troisieme, on en décrira une du quatrieme; et ainsi a l'infini, comme il est fort aysé a connoistre par le calcul.²⁴

Calculations themselves fail to come up with Descartes' expectations. In fact, as Fermat will show with a simple but accurate counterexample, if one inserts in the linkage described in the second Book of *La Géométrie* (see Descartes [1897-1913], vol.6, p. 393), following Descartes' instructions, a particular curve of the third class (namely, the cubic: $y^3 = x$), the new geometric linkage will trace a curve of the third class again, and not of the next higher class, as Descartes predicted.²⁵

From this counterexample, we can conclude that the cartesian classificatory scheme of curves based on the degree of their associated equations fails to capture some relevant aspects of the constructional and, more generally, geometrical complexity of curves. I surmise that this failure engenders a tension, in Descartes' ordering of problems and curves, between specification by genesis and specification by property, in the sense that curves constructionally more complex than other ones does not necessary fall into a higher kind. An analogous tension caused by an imperfect mirroring between the complexity of

²⁴Descartes [1897-1913], vol.6, p. 395. See this study, chapter 3, section 3.2.

²⁵*Cf.* Mahoney [1973], p. 136.

the construction of a curve, on one hand, and its algebraic characteristics like the degree, on the other, will emerge also in the opposition between simplicity and easiness, as I will develop in the sequel.

4.3.3 A Classification of problems

Similarly to the case of curves, Descartes sketched a hierarchy of problems by sorting them out into classes according to the degree of their associated equations. This classification does not occupy a dedicated section in the treatise, but it is deployed throughout Book I to Book III of *La Géométrie*.

For instance, the classification of curves articulated in the second Book of *La Géométrie* is applied, few lines after having been introduced, in order to classify the various cases of Pappus' problem, as the following survey made by Descartes reveals:

Or après avoir ainsy reduit toutes les lignes courbes a certains genres, il m'est aysé de poursuivre en la demonstration de la reponse, que j'ay tantost faite a la question de Pappus. Car premierement ayant fait voir cy dessus, que lorsqu'il n'y a que trois ou 4 droites données, l'equation qui sert à déterminer les points cherchés, ne monte que iusqu'au carré; il est evident que la ligne ou se trouvent ces points est necessairement quelque une de celles du premier genre, a cause que cete mesme equation explique le raport, qu'ont tous les points des lignes du premier genre a ceux d'une ligne droite. Et que lorsqu'il n'y a point plus de 8 lignes droites données, cete equation ne monte que iusqu'au quarré du quarré tout au plus, et que par consequent la ligne cherchee ne peut estre que du second genre tout au plus . . .²⁶

Descartes proceeds, in the same Book II, to prove the results stated above, at least for the problem of Pappus in three or four given lines, and shows that one can obtain all conic sections as solutions; then he goes on to examine cases of Pappus' problem in a higher number of lines, and discusses the corresponding curve-solutions. Recently, scholars have investigated in detail both Descartes' exposition of the solution of the problem of Pappus, made in the second Book of *La Géométrie*, and the ancillary discussions raised by the recipients and correspondants within Descartes' circle.²⁷ This section of Descartes' work is therefore well known, and since it is not directly relevant to my present theme, I shall

²⁶Descartes [1897-1913], vol. 6, p. 396.

²⁷In particular: Bos [1981], p. 299-300, 315, 332ff. Bos [2001], chapter 23 in particular; see also: Maronne [2007].

confine myself to schematizing the core of Descartes' classification as it results from the summary offered in the above passage:

- If the locus is in 3 or 4 lines, the equation of the locus is of degree at most 2, the locus is of the first class, on the ground of the previous classification of curves.
- If the locus is in 5, 6, 7 or 8 lines, the equation of the locus is of degree at most 4, the locus is of the second class (even if, in exceptional cases, the locus is of the first class).
- If the number of given lines is between 9 and 12, the equation of the locus is of degree at most 6, so that the locus is of the third class, and of the lower class in exceptional cases.
- *etc.*

But this is not the only classification of the problems of Pappus discussed in Descartes' *Géométrie*. In the final section of Book I, in fact, Descartes sketches another general classification that, in his hopes, ought to encompass all instances of Pappus' problem. As in the previous classification, different cases are singled out into classes according to the degree of the equation (namely $F(x, y) = 0$) obtained as a result of their analysis. Hence, if we call n the number of given lines and k the degree of the equation associated to the problem, the classification deployed by Descartes boils down to the following scheme:²⁸

- For $n = 3, 4$ and $n = 5$, in the case of five non-parallel lines, the degree of the associated equation will be at least $k = 2$, and the points on the locus can be constructed by ruler and compass;
- For 5 parallel lines, $6 \leq n \leq 8$, and $n = 9$, if 9 lines are non parallel, the degree of the associated equation will be $k = 3, 4$: the points on the locus can be constructed by intersection of conic sections;
- For 9 parallel lines, $10 \leq n \leq 12$, and $n = 13$, if the configuration of the problem presents thirteen, non parallel lines, the degree of the associated equation will be $k = 5, 6$. Descartes asserts that the points on the locus cannot be constructed without the employment of curves more complicated than conic sections.

²⁸See Descartes [1897-1913], vol. 6, p. 386-387. For an exhaustive discussion of Pappus' problem, the derivation of the equation for its locus and the constructions, see Bos [2001], especially chapter 23.

The rationale of the classification presented in the first book is subtly different from the one of the second Book, that I have presented before. Indeed, it reflects a hierarchical order among the cases of the problem of Pappus with respect to the pointwise constructability of the curve-solutions: this classification is not grounded on the class of the curve or locus that offers the solution to the problem, but on the means (namely, the curves) that can effectuate its pointwise construction.

As seen in the previous chapters, Descartes set up a uniform methodology in order to treat the constructions of indeterminate and determinate problems alike. Essentially, indeterminate problems are solved once their corresponding equations in two unknowns, i.e. $F(x, y) = 0$ are reduced to equations in one unknown. i.e. $F(x, a) = 0$. The problem of Pappus in 3 and 4 lines, for instance, is reducible to a second degree equation, and can be constructed - so Descartes relates - in the same way as a determinate problem of the same degree, namely by ruler and compass.²⁹

If one wishes to construct the curve-solution of a case of Pappus' problem in higher number of lines, the ruler and the compass soon become inadequate. As Descartes suggests in Book I, the case of Pappus' problem in five lines, four of which are parallel, illustrates well this difficulty: the corresponding equation will be of third degree and - Descartes maintains - cannot be constructed by ruler and compass, but will require conic sections instead. In an analogous way, when the equation to which the problem has been reduced is of degree five or six, then its solution will admit of curves "one degree higher than the conic sections" (Descartes [1897-1913], vol. 6, p. 387).

I point out that Descartes does not explain, in Book I, why a problem of Pappus in more than three or four lines, reducible to an equation of degree higher than 2, is not constructible by ruler and compass. The relation between degree and constructability is further studied in the third book of *La Géométrie*, where Descartes discusses the construction of equations and correlated problems in a more thorough way.

Perhaps not surprisingly, we find, in that book, a classification of problems (both determinate and indeterminate) into classes, which follows the same rationale of the classification

²⁹See Descartes [1897-1913], vol. 6, p. 374, p. 386. In exceptional cases, the equation corresponding to a locus of the problem of Pappus is in one unknown only. This occurs when the given $2n$ and $2n - 1$ lines are all parallel: the result will be an equation in one unknown, of degree at most n , and the locus will consist in a number of straight lines parallel to the given lines (Bos [1981], p. 300).

of locus problems presented in the first Book (and schematized above). Basically, the kind to which a problem belongs is grounded on the degree of the associated equations:

... si la quantité inconnue a 3 ou 4 dimensions, le Probleme pour lequel on le cherche est solide, et si elle en a 5, ou 6, il est d'un degré plus composé, & ainsi des autres (...) ...³⁰

Few lines below Descartes adds:

Or, quand on est assuré que le problème proposé est solide; soit que l'équation par laquelle on le cherche monte jusqu'au quarré du quarré, soit qu'elle monte jusqu'au cube, on peut toujours en trouver la racine par l'une des trois section coniques ...³¹

On one hand, Descartes sketches, in these passages, a pairwise classification of problems based on the degree of their associated curves, and claims that the degree of the equation (provided the equation cannot be factored any further: I will discuss the problem of factorization, in more detail below) on which a problem depends gives information on the required solving means.

Descartes' classification did not end here, at any rate, but was conceived as indefinitely continuing. For instance, problems of higher degree than the five or sixth are mentioned elsewhere, as we can read in a letter to Mersenne dating from 1638:

... de façon que ceux qui ont envie de faire paroistre qu'ils sçavent autant de Geometrie que j'en ay escrit (...) devroient plustost s'exercer (...) a construire tous les Problemes qui montent au quarré du quarré du quarré, ou au cube de cube, comme j'ay construit tous ceux qui montent jusqu'au quarré de cube.³²

Generally speaking, Descartes maintained that a class of level n should contain problems reducible to equations of degree $2n$ and $2n-1$. Starting with $n = 1$, problems reducible to equations of degree 2 or 1 belong to the same class, then problems reducible to equations of degree 4 and 3 ought to be ranged in the same class, different from the previous

³⁰Descartes [1897-1913], vol. 6, p. 464. The term "degré" is here vague. In fact it can be doubted that it refers to the algebraic notion of degree of the equation, for which Descartes generally employed the french term 'dimension'. Descartes might be referred to the level of the problem, in the hierarchy established by the degree of the associated equation.

³¹Descartes [1897-1913], vol. 6, p. 464.

³²Descartes [1897-1913], vol. 1, p. 493.

one, and so on, along the same pattern, for any n . This numerical classification is of a descriptive type: a problem belongs to the first, second . . . n^{th} class because its associated equation has recognizable properties, expressed by its degree.

Let us remark that Descartes also gave concession to the classical, pappusian terminology, as he currently employed adjectives as "plane" and "solid" in order to refer to the nature of problems, together with newly cashed-out terms as "one-level more complex" ("*un degré plus composé*") which stood for geometric questions never or hardly ever addressed by the ancients, or generally ranged among the "linear" ones, according to Pappus' lexicon.³³

The use of such a classical terminology underscores, I surmise, an important connection between Descartes' and Pappus' classifications. Problems reducible to quadratic equations are judged, in fact, 'plane' because they can be solved by the intersection of circles and straight lines. Likewise, problems reducible to third and fourth degree equations are 'solid' as they require the use of at least one conic section for their solution. Hence, the hierarchy of problems classified according to the degree of their associated equations, at least for what concerns the first and the second class, incorporated the classical distinction into solid and plane problems into a larger scheme, extendible in principle to any geometric curve and problem, provided it could be reduced to a finite polynomial equation.

But the pairing between Descartes' numerical classification based on the degree of the associated equation (provided it cannot be further reduced: this point will be touched also later on) and the pappusian classification into plane and solid problems, asserted already in the first Book of *La Géométrie* is not obvious.

If we remain to Descartes' general deliberations offered in Book I, it seems that the construction of a problem, once it had been reduced to an equation, and after having applied all 'possible divisions' in order to see whether its degree can be lowered, would

³³Indeed the only problems unsolvable either by conic sections or plane means known to the Greeks either concerned the rectification of the circumference, or the division of the angle into an arbitrary number of parts. For instance, there are no extant sources attesting that ancient Greeks geometers occupied themselves with the construction of regular polygons non constructible by ruler and compass (these were dealt with in Euclid's Book IV of the Elements) or by solid techniques (the only case, concerning the construction of a regular heptagon, is extant in arabic, but not in Greek sources: see HOGENDIJK [1984]), like the regular polygon with 11 or 13 sides, two examples of polygonal constructions evoked in Descartes' *Géométrie* (Descartes [1897-1913], vol. 6, p. 484) as instances of problems "one-degree more complex" than the solid ones.

follow as an almost obvious consequence.³⁴ We can concede that questions reducible to quadratic equations did not pose any problem for Descartes: as it was sanctioned by a long tradition of studies, the appeal to "la Geometrie ordinaire", namely to by straight lines and circles "tracées sur une superficie plate", represented the most natural choice.³⁵

On the contrary, the choice of the solutions in the case of higher degree problems was not an obvious matter for early modern geometers, nor for Descartes.

As our overview in chapter 2 has shown, problems unsolvable by Euclidean means, like the insertion of two mean proportionals or the trisection of an angle were not treated in a unitary way before the advent of Descartes' problem-solving strategy, but broached by several techniques. These problems were either treated by means of *neusis* constructions (see ch. 2, p. 45), or by employing conic sections (foreexample, an hyperbola and a circle, employed in order to construct the neusis required for the trisection discussed in the *Collection*. See ch. 2, p. 50; or an hyperbola and a parabola, for the well-known case of the insertion of two mean proportionals, handled by Maenechmus. For this last example, see 3, 120 ff.), or linear curves, as in Pappus' construction of two mean proportionals, which demands to trace a conchoid (see ch. 2, sec. 2.3.1).

In these cases, it was not the lack of solving methods, but their excess which might cause troubles for a rational organization of curves and problems. How can one decide, in fact, the most adequate method in order to construct an equation or a problem, when different possibilities are available, and are all technically correct? In order to answer to this question, Descartes introduced the normative requirement which proclaims to solve each problem in the dimensionally simplest manner, that we have examined in the first section of this chapter. On the ground of this principle of simplicity, Descartes could adopt the classical terminology of 'plane', when referring to problems reducible to quadratic equations, and 'solid', when referring to problems reducible to equations in the fourth or third degree.

³⁴Cf. Descartes [1897-1913], vol. 6, p. 374.

³⁵Cf. Descartes [1897-1913], vol. 6, p. 374. On the construction of quadratic equations by ruler and compass, before Descartes, see: Bos [2001], chapter 4. In particular, Descartes states, in the first Book of *La Géométrie*, that if a problem is "plane", then: "... lorsque la derniere equation aura esté entierement démeslée, il n'y restera tout au plus qu'un quarré inconnu, esgal a ce qui se produit de l'Addition, ou soustraction de sa Racine multipliée par quelque quantité connue, et de quelque autre quantité aussy connue" (Descartes [1897-1913], vol. 6, p. 374). As correctly observed in Lützen [2010] (p. 13) this statement is not proved. A proof of the converse claim is given instead: if a problem can be associated to a quadratic equation, at the end of analysis, then it is constructible by the means of ordinary geometry (Descartes [1897-1913], vol. 6, p. 375ff.).

I shall discuss, in the following section, this requirement in the context of a case study, namely the problem of inserting two mean proportionals, and argue that the choice of dimensional simplicity is by no means an obvious strategy to take, especially if we confront it with other possible strategies arisen in the very activity of problem solving.

4.4 Construction of third and fourth degree equations

A core result in the domain of solid problems, obtained by the end of XVIth century, was the following: any problem leading to fourth or a third degree equations could be effected by means of ruler and compass, and by either solving the problem of inserting two mean proportionals or by solving the trisection of an arbitrary angle. This result was stated in the final proposition of François Viète's *Supplementum Geometriae*, published in 1593.³⁶ Certainly aware of Viète result, early modern geometers must have concluded, in the backdrop of their knowledge of Pappus' *Collection*, that any problem leading to fourth or third degree equations could be effectuated by straight lines, circles and by conic sections: it was therefore a solid problem, according to the classification of Pappus.³⁷

Starting from these results, Descartes succeeded in framing into a unitary strategy the different cases of problems leading to cubic (and quartic) equations, based on a unified geometric procedure in order to construct fourth and third degree equations, that he published for the first time in *La Géométrie*.³⁸

Let us recall that in cartesian geometry, all equations code proportions between segments, and are therefore algebraic equations of finite degree. The construction of an equation

³⁶This result is contained in proposition XXV, labelled: "*Consectarium generale*" (Viète [1646], p. 256). For conciseness, we might resume the procedure followed by Viète by observing that it conflates an algebraic and a geometric part. Firstly, Viète relied on a result obtained in another work of him, the *De aequationum recognitione et emendatione tractatus duo* (published only in 1615) in order to state that all fourth degree equations could be reduced, via quadratic equations, to third degree ones, and any equation of third degree could be reduced to the following forms by removing the quadratic term: (i) $x^3 = a^2b$; (ii) $x^3 + a^2x = a^2b$; (iii) $x^3 - a^2x = a^2b$; (iv) $a^2x - x^3 = a^2b$, with $a, b > 0$. Subsequently, Viète argued that the cases of third degree equations just listed not only formed a complete set, in the sense that any cubic equation could be reduced to one of these forms, but they (or their suitable variants) corresponded either to the problem of inserting two mean proportionals, or to the trisection of an angle (for a presentation of this result, see Bos [2001], ch. 10). Hence, any fourth or third degree equation could be solved by straight lines, circles (let us recall, indeed, that quadratic equations are involved in the reduction of a fourth degree equation) and by constructing either the problem of inserting two mean proportionals between given segments or by trisecting an angle.

³⁷I point out, however, that Viète did not rely on the intersection of curves in order to solve solid problems, but on constructions by neusis, that he grounded on a specific postulate, in his *Supplementum geometriae*. See Viète [1646], p. 240.

³⁸Although the discovery of both constructions dates back to the 1620s (See Bos [2001], chapter 17).

was, in Descartes' programme, a technique consisting in exhibiting, through the intersection of a pair chosen curves, as many segments as the number of real positive root(s) of the equation at hand.³⁹ Generally speaking, the aim of Descartes' solving strategy consists in finding, given an algebraic equation in one unknown, like $H(x) = 0$, resulting as the outcome of the analytical stage, two curves F and G of equation, respectively, $F(x; y) = 0$ and $G(x; y) = 0$, such that the roots of $H(x) = 0$ occur among the abscissae of their intersection points.

In more formal terms, this comes down to state that the first member of the equation $H(x) = 0$, that we consider irreducible,⁴⁰ must be a factor of $\mathfrak{R}_{F;G}(x) = 0$, i.e. the equation obtained by eliminating y from $F(x; y) = 0$ and $G(x; y) = 0$.⁴¹

I will refer to Bos [1984] for a general presentation of the technique for constructing equations. Let us consider, in order to offer sketch of its main tenets, the general case of a problem, whose analysis has provided the following equation:

$$H(x) = a_n x^n + a_{n-1} x^{n-1} + a_{n-2} x^{n-2} \dots + a_1 x + a_0 = 0$$

Constructing this equation boils down to exhibit two geometric curves \mathcal{F} and \mathcal{G} of equation, respectively, $F(x; y) = 0$ and $G(x; y) = 0$, such that the roots of $H(x) = 0$ occur among the abscissae of their intersection points. These curves are required to obey to the

³⁹The technique for solving equations geometrically was a subject of research in mathematics and part of current teaching between 1637 (indeed, the first contributions made by Descartes are exposed in Book III of *La Géométrie*) and approximately 1750. The subject is exposed in detail in Bos [1984]. In here, the author does not limit to treat it as a "technique" in geometry, but it goes on to consider it a "mathematical theory" strictly related to the theory of curves and the algebraic theory of equations, and offers a study of the reasons of its rise and subsequent decline during the half of XVIIIth century.

⁴⁰The algebraic structure to which the coefficients of the equations discussed in *La Géométrie* generally belong is the ring $\mathbb{Z}[a, b, c, \dots]$, obtained from the ring of the integers by adding a finite number of independent quantities, that express the given segments of the problem from which the equation to be studied derives. The polynomials considered by Descartes are always monic, namely, they have leading coefficient equal to 1, or are always reducible to monic polynomials. The reason of choosing the special ring $\mathbb{Z}[a, b, c, \dots]$ is well grounded in the text of *La Géométrie*. In fact Descartes gives, in Book III, general rules in order to transform all the rational coefficients appearing in an equation $H(x) = 0$ into integers, and all irrational into rationals, whenever it is possible (Descartes [1897-1913], vol. 6, p. 454). Once performed these transformations, one can obtain an equation in integer coefficients, with leading coefficient equal to 1, while the degree remains unaltered. Descartes illustrated other transformations, which modify the equation still leaving unchanged its degree: he taught how to change all negative roots into positive ones, and how to suppress the term x^{n-1} in a n^{th} -degree equation (Descartes [1897-1913], vol. 6, p. 455-456).

⁴¹On the peculiar notion of reducibility evoked here, see below, section 4.5.2 of this chapter.

following conditions: (i) they both have to be geometrical curves (a condition assured by their expressability through algebraic equations); (ii) the abscissas of their intersection points must be roots of the equation $\mathcal{R}_{F,G}(x) = AH(x) = 0$, where A is a constant, or a polynomial in x . The $\mathcal{R}_{F,G}(x) = 0$ is the equation obtained by eliminating y from $F(x; y) = 0$ and $G(x; y) = 0$;⁴² (iii) the curves \mathcal{F} and \mathcal{G} must belong to the simplest kind which construct the equation.

We do not meet this abstract presentation anywhere in *La Géométrie*, although we find in this treatise noteworthy applications to the construction of particular equations, and to the solution of associated geometric problems.⁴³

Let us now examine how the cartesian technique of the construction of equations works, for the cases associated to special problems discussed in *La Géométrie*, like the problem of finding two mean proportionals between two given segments, offered in Book III of *La Géométrie*.

4.4.1 Construction of a cubic equation

As I have pointed out in chapter 3 (sec. 3.1.1) the geometric analysis of the problem has lead to a cubic equation: $z^3 - a^2q = 0$, with a single real root for any choice of the givens a and q .

Descartes derives the construction of this equation by adapting to this specific case a general procedure for constructing third and fourth degree equations. He discusses several constructions, corresponding to the different cases of the equations: $z^3 = \pm apz \pm a^2q$ and $z^4 = \pm apz^2 \pm a^2qz \pm a^3$,⁴⁴ and obtains, as a general result, that the (real) roots of third and fourth degree equations can be constructed by intersecting a given Parabola with a circle.⁴⁵ Let us consider, for instance, how Descartes' procedure can be applied to the construction of a general third degree equation:⁴⁶

⁴²See Bos [1984], especially p. 342-345 for the technical details; and Bos [2001], chapter 26.

⁴³See, in particular, chapter 2. See also Galuzzi [2010], p. 551.

⁴⁴Descartes [1897-1913], vol. 6, p. 464. Descartes did not use this notation, which is a modern reformulation adopted, for instance, in the English translation by Smith and Latham. In fact we read in the original: " $z^4 = * .apzz. aaqz$ ", and " $z^3 = * .apz. aaq$ ".

⁴⁵Descartes also states, without proof, that the same result can be obtained by substituting to the Parabola an Ellipse or an Hyperbola: see Descartes [1897-1913], vol. 6, p. 464.

⁴⁶Descartes [1897-1913], vol. 6, p. 465. I shall not give here the analysis, which is not offered by Descartes either. An example of analysis can be found in Van Schooten's Commentary: Descartes [1659-1661], vol. 1, p. 324.

$$P(z) = z^3 + pz + q = 0$$

According to the cartesian protocol, a parabola is supposed given, with axis POT , vertex O and *latus rectum* $a = 1$ (see fig. 4.4.1). A segment $OC = \frac{1}{2}$ is then taken on the axis, together with a point P , whose distance from C is $CP = \frac{1}{2}p$ (P must be chosen within the parabola if $p < 1$, and upward if $p > 1$). From point P , Descartes' procedure requires to trace a segment $PR = \frac{1}{2}q$ (I note that PR is traced to the left, since q is positive in the equation $P(x) = 0$. If q is negative, PR must be constructed on the right). With R as center, the circle with radius RO is traced, which intersects the parabola in another point (for the case at hand). Let us call ' S ' the intersection point. ST will be the required (real) root of the equation $P(z) = 0$, which must be taken as negative if S lies on the left of T (positive otherwise).

A justification of the soundness of the above construction can be given, following Descartes' reasoning, by solving this geometric problem:

Problem. Given a parabola with vertex O , axis POT and *latus rectum* equal to 1, and a circle with center R and radius RO , to find the length of ST , intersection between the parabola and the circle, provided segments OC , CP , PR are given (4.4.2).

Following Descartes' analytic strategy, we can name the segments: $ST = -z$, and $OT = y$. Since RO and RS are radii of the same circle of center R , $RO = RS$. Moreover, ROP is a right-angled triangle by construction, hence: $RO^2 = RP^2 + PO^2$. By tracing the perpendicular SM from S to RP , a second right-angled triangle RMS can be constructed, such that: $RS^2 = RM^2 + MS^2$.

Let us consider the latter equality. We have set: $ST = -z$ and $RP = \frac{1}{2}q$. Hence $RM^2 = (RP - ST)^2 = (\frac{1}{2}q + z)^2$. It is clear from the diagram that $MS = PT$, and $PT = PO + OT$, and by setting $OT = \frac{1}{2}p - \frac{1}{2}$, $PT = y + (\frac{1}{2}p - \frac{1}{2})$. Therefore $MS^2 = (y + (\frac{1}{2}p - \frac{1}{2}))^2$. We can write, by consequence:

$$RM^2 + MS^2 = RS^2 = (\frac{1}{2}q + z)^2 + (y + (\frac{1}{2}p - \frac{1}{2}))^2. \quad (4.4.1)$$

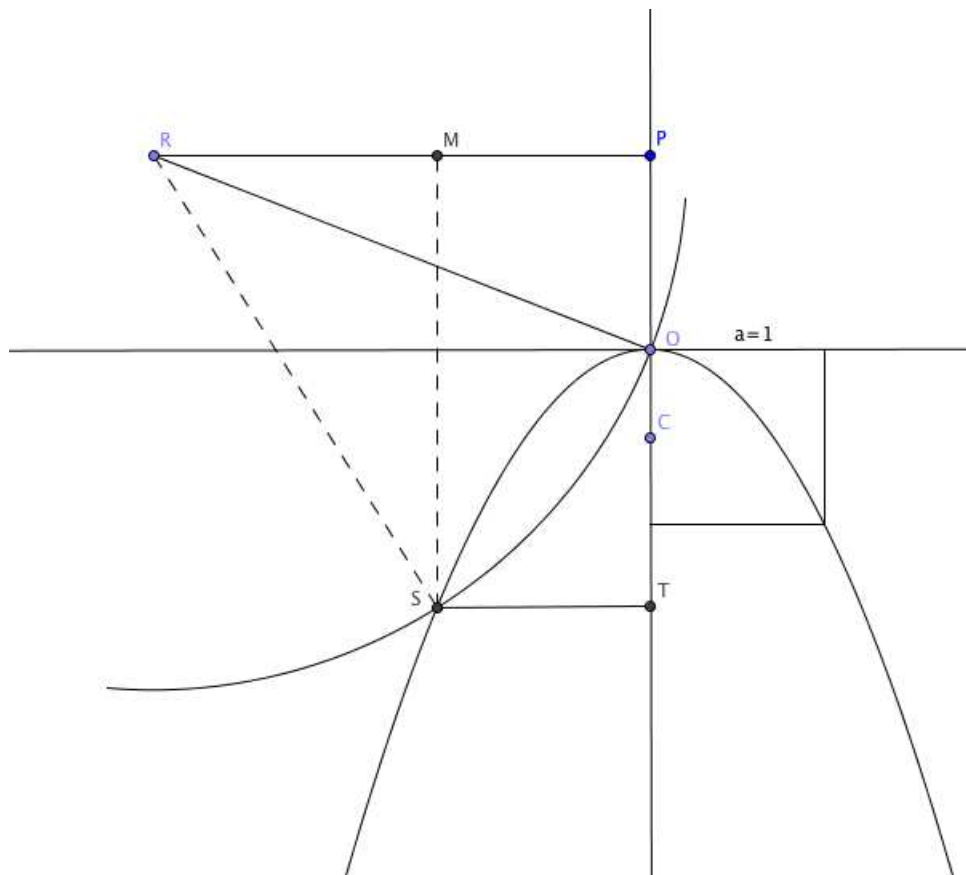

Figure 4.4.1: Construction of a cubic equation.

Let us then consider the equality: $RO^2 = RP^2 + PO^2$. Since $RP = \frac{1}{2}q$ and $PO = (\frac{1}{2}p - \frac{1}{2})$, we infer:

$$RO^2 = \frac{1}{4}q^2 + \left(\frac{1}{2}p - \frac{1}{2}\right)^2. \quad (4.4.2)$$

If we equate the 4.4.1 and the 4.4.2, the equation for the circle with center R and radii RO and RS will be:

$$\left(\frac{1}{2}q + z\right)^2 + \left(y + \left(\frac{1}{2}p - \frac{1}{2}\right)\right)^2 = \frac{1}{4}q^2 + \left(\frac{1}{2}p - \frac{1}{2}\right)^2.$$

Simplifying this expression, we obtain:

$$y^2 + z^2 + qz + (p - 1)z^2 = 0 \quad (4.4.3)$$

If $ST = -z$, then $TO = y = z^2$, since, by the nature of the parabola, we have (let us recall that we have the *latus rectum* equal to 1):

$$TO : ST = ST : \textit{latus}$$

We can substitute z^2 in the 4.4.3, and obtain:

$$z^4 + pz^2 + qz = 0.$$

But this equation can be simplified, since: $z^4 + z^2 + qz + (p - 1)z^2 = z(z^3 + pz + q) = 0$, which is equal to the equation $P(z) = 0$ multiplied by a factor z . If we leave this factor out, the remaining roots of the equation $z^4 + pz^2 + qz = 0$, are the same roots of $P(z) = 0$. Therefore the length of ST can be found by constructing the equation $P(z) = 0$. This conclusion warrants the correctness of the previous procedure for the construction of equation $z^3 + pz + q = 0$.

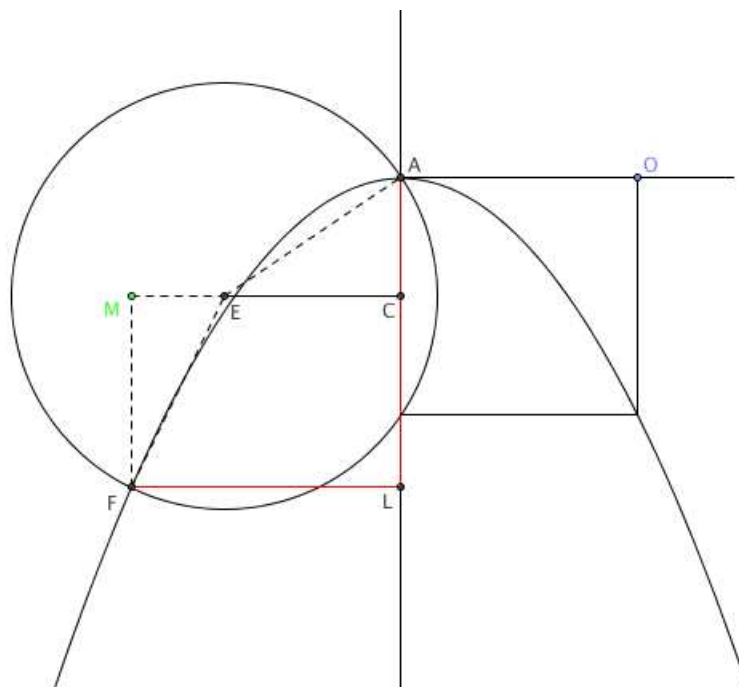

Figure 4.4.2: The insertion of two mean proportionals according to Descartes.

4.4.2 The insertion of two mean proportionals

The problems of inserting two mean proportionals and the problem of trisecting an angle, both reducible to cubic equations, are constructed by Descartes, in Book III of *La Géométrie*, by adapting the above protocol to particular geometric situations.

Let us consider in more detail the case of the problem of inserting two mean proportionals between the given segments a and q . Following Descartes' argument in *La Géométrie*, let us suppose that a parabola \mathcal{P} is given with vertex A (which is its highest point) and with *latus rectum* $AO = a$ (fig. 4.4.2). Let us mark a point C on the axis, such that $AC = \frac{1}{2}a$, and from C raise the perpendicular CE to the axis, such that $EC = \frac{1}{2}q$. A circle \mathcal{C} must then be constructed, with center E , and which cuts the parabola at its vertex A (see 4.4.2). As shown in figure, the circle will cut the parabola at another point F . Segments FL , namely the distance of F from the principal axis of the parabola, and segment AL , cut on the principal axis, will be the sought for solutions for the problem of inserting two mean proportionals between a and q .⁴⁷

⁴⁷Descartes [1897-1913], vol. 6, p. 469.

We can verify that both curves construct the equation $z^3 - a^2q = 0$ according to the general protocol for the construction of equations, and on this ground they can construct the original geometric problem too. Firstly, it is immediate to check that the circle and the parabola are geometrical curves. It is less easy to verify that the resultant $\mathfrak{R}_{\mathcal{P},\mathcal{C}}(x)$, namely the equation obtained by eliminating y from $\mathcal{P}: F(x, y) = 0$ and $\mathcal{C}: G(x, y) = 0$, equals the polynomial equation: $z^3 - a^2q = 0$, in case multiplied by a factor z (condition ii above).

Condition (ii) can be verified in the following way. Let us set: $FL = z$ and $AL = y$. Since F lies on the parabola \mathcal{P} with parameter $OA = a$, we can derive the following equation for \mathcal{P} : $F(x, y) = z^2 - ay = 0$. Let us draw the auxiliary segment FM , perpendicular to EC . By construction, $EC^2 + AC^2 = EA^2$, and $EM^2 + FM^2 = EA^2$. From this we can deduce: $EA^2 = \frac{q^2}{4} + \frac{a^2}{4}$. But we also have by construction: $FM^2 = (AL - AC)^2 = (y - \frac{a}{2})^2$, and $EM^2 = (FL - EC)^2 = (z - \frac{q}{2})^2$. At this point, we can elementarily derive: $EF^2 = EM^2 + FM^2 = (z - \frac{q}{2})^2 + (y - \frac{a}{2})^2 = z^2 + \frac{q^2}{4} - qz + y^2 + \frac{a^2}{4} - ay$. Since $EF = EA$ (they are both radii of the same circle), this equality will follow: $z^2 + \frac{q^2}{4} - qz + y^2 + \frac{a^2}{4} - ay = \frac{q^2}{4} + \frac{a^2}{4}$, which yields the following equation for the circle \mathcal{C} : $G(x, y) = z^2 + y^2 - qz - ay = 0$.

We can now form the system:

$$\begin{cases} F(x, y) = z^2 - a.y = 0 \\ G(x, y) = z^2 + y^2 - qz - ay = 0 \end{cases}$$

And by eliminating y from both equations we obtain $\frac{z^4}{a^2} - zq = z(z^3 - a^2q) = 0$. But this equation yields exactly the equation associated to the problem of inserting two mean proportionals (namely: $z^3 - a^2q$), multiplied by a factor z .⁴⁸

⁴⁸A geometric proof of the correctness of Descartes' construction was provided not by Descartes himself, but by two outstanding mathematicians, Mydorge and Roberval, who also attained the same result, probably independently. I remark that Descartes firstly communicated to Mersenne, during the year 1625-1626, the construction (without proof) of the mean proportional problem, by intersecting a circle with a given parabola. Hence, this solution was discovered well before the writing of *La Géométrie*. Descartes' construction, accompanied by a proof given by Roberval, was published by Mersenne in his *Harmonie Universelle* (1636). Meanwhile, in 1628, Descartes showed his construction to Beekman too, together with a proof (this time the proof had been given by Mydorge), and a general construction for the roots of the third and fourth degree equations, later elaborated in the third Book of *La Géométrie*. Cf. Bos [2001], p. 255. For details on Roberval's proof, see Descartes [1897-1913], vol. X, p. 655-657.

A construction by a parabola and a circle is given by Descartes for the problem of trisecting an angle too.⁴⁹ Hence, Descartes' general procedure for constructing fourth and third degree equations proves that any problem reducible to them is constructable by the same apparatus, formed by a conic section plus the use of ruler and compass: hence, any problem reducible to a fourth or third degree equation will be solid, in the sense of Pappus' classification.

This conclusion, as I have argued in the foregoing, was already well-known by the time the *Géométrie* went into press.⁵⁰ Nevertheless, Descartes made an original contribution to the history of the trisection and mean proportional problems. Indeed, for what concerns the trisection problem, the only construction transmitted in ancient texts contemplated the use of a hyperbola and a circle: it can be found in Pappus' *Collection*, in prop. 31 (*Cf.* ch. 2, p. 45). Descartes probably considered his own achievement, consisting in a solution obtained by means of a parabola and a circle, as a gain in simplicity with respect to the construction provided by the Ancients, as he judged the parabola the simplest conic section.⁵¹

On the other hand, the problem of inserting two mean proportionals had been effectively solved through a parabola and a circle before XVIIth century. However, this solution can be encountered only in the book titled: *Istikmal* ("Perfection"), and written in the Xth century by the Andalusian mathematician Yusuf Al-Mu'taman ibn Hud.⁵² However, it seems unlikely that early modern mathematicians or, at least, those mathematicians acquainted with Descartes, had any knowledge of this work. Therefore a construction of the problem of inserting two mean proportionals, obtained by a parabola and a circle was probably a novelty when Descartes produced it.⁵³

⁴⁹Descartes [1897-1913], vol. 6, p. 473. The idea of simplicity here evoked is certainly not 'dimensional simplicity', because all conic sections are associated to equations in the same degree. However, Descartes did not explain why the parabola should be considered simpler than the other conic sections, like the hyperbola. This judgement might depend on the fact that the parabola, via an opportune choice of the axis, can be endowed with a simpler equation than the one associated to the hyperbola (*Cf.* Descartes [1659-1661], vol. 1, p. 174ff.).

⁵⁰Descartes was certainly aware of the results obtained by Viète, concerning the relation between fourth and third degree equations and solid problems. Indeed the *Supplementum geometriae* was published during Viète's lifetime, and most of Viète's principal works had been published in 1615 by Anderson, and in 1631, by Beaugrand. However, let us recall that Descartes maintained a disparaging attitude towards Viète: Descartes [1897-1913], vol. 1, p. 479-480.

⁵¹Descartes [1897-1913], vol. 6, p. 464.

⁵²*Cf.* Hogendijk [1992].

⁵³This invention was highly valued by Descartes himself, as we can read from Beeckman's testimony: "Mr Descartes values this invention so much that he avows never to have found anything more outstanding, indeed that nothing more outstanding has been found by anybody" (Descartes [1897-1913],

To these remarks, we should add the fact that construction by conic sections were rarely employed by XVIth and XVIIth century geometers, before the publication of *La Géométrie*, so that Descartes' solutions appeared as a novelty, in the backdrop of the constructional tradition of the problems of trisecting an angle and duplicating the cube (or inserting two mean proportionals).⁵⁴

On the top of that, Descartes's protocol for constructing quartic and cubic equations might have represented a valuable contribution towards a rational organization of problems into classes. In fact, despite the solvability of fourth and third degree equations by conic sections and plane means was known to mathematicians before Descartes, no uniform feasible procedure was available in order to construct them.

We can extrapolate from Viète's narration an abstract argument, proving that problems reducible to equations in the fourth and third degree are constructable by conic sections (and by circles). However, we cannot find anywhere, in Viète's work, a unique procedure in order to solve both quartic and cubic equations and the related geometric problems. Indeed, no constructional procedure was available, in Viète's overall problem solving technique (presented, in particular, in the *Supplementum geometriae*), in order to directly construct quartic equations. He rather opted for reducing fourth degree equations to third degree ones, via purely algebraic transformations. The (real) roots of the third degree equation so obtained could be constructed by solving either the problem of inserting two mean proportionals or trisect the angle, via a *neusis* construction (*Cf. Supplementum geometriae*, proposition V, IX, in Viète [1646], p. 240ff.).

But whereas Viète had merely proved the constructibility of fourth degree equations,⁵⁵ Descartes had framed, in *La Géométrie*, a uniform strategy for their construction, together with the construction of cubic ones. In his eyes (as well as in the eyes of his fellow mathematicians) this result might be seen as a felicitous consequence of the choice of relying on the simplicity of curves, measured by algebra, in order to perform the construction of equations and problems.

vol 10, p. 346: "Hanc inventionem tanti facit D. des Chartes, ut fateatur se nihil unquam praestantibus invenisse, imò a nemine unquam praestantiùs quid inventum").

⁵⁴One of the more extensive treatments of solid problems by means of conic sections (and plane means) remained Commandinus' Commentary of Pappus' *Collection*, especially on propositions 31 and 34 (*cf. Commandinus* [1588], fol. 62r, fol. 64r).

⁵⁵Bos [2001], p. 259.

Descartes did not limit his considerations to the organization of conic-constructible problems. In fact he extrapolated, from the construction of plane and solid cases, a general protocol in order to construct higher degree problems. This protocol is resumed in the closing paragraph of the text:

Puis outre cela, qu'ayant construit tous ceux qui sont plans, en coupant d'un cercle une ligne droite, & tous ceux qui sont solides, en coupant aussy d'un cercle une parabole, & enfin tous ceux qui sont d'un degré plus composé, en coupant tout de mesme d'un cercle une ligne qui n'est que d'un degré plus composée que la Parabole, il ne faut que suivre la mesme voye pour construire tous ceux qui sont plus composés à l'infini.⁵⁶

With these final words, the route to follow in order to solve problems of any class was thus traced. Descartes' choice relied on a generalization of the protocol adopted for the construction of equations up to degree four (and their corresponding problems): in fact any higher degree equation should be constructed, according to his scheme, by intersecting a circle with another curve, selected on the basis of dimensional simplicity.⁵⁷

4.5 Easiness versus simplicity

4.5.1 Two solutions compared

Descartes was also aware that the preference for dimensional simplicity, in deciding the most adequate curve for a problem at hand, was not the only available choice.

In fact nothing, in the algebraic procedure which underscores the construction of an equation, constrains to the choice of a certain solution. This underdetermination has a precise mathematical explanation, related in these terms by H. Bos: "algebraically, the problem of constructing equations is an inverse elimination problem. In a direct elimination problem the equations $F(x, y) = 0$ and $G(x, y) = 0$ are given and it is required to eliminate y , that is to determine $\mathfrak{R}_{F;G}$. Here $H(x)$ is, however, given and $F(x, y)$ and $G(x, y)$ have to be found such that $\mathfrak{R}_{F;G}(x) = H(x)$, or $\mathfrak{R}_{F;G}(x)$ has $H(x)$ as a factor".⁵⁸

⁵⁶Descartes [1897-1913], vol. 6, p. 485.

⁵⁷Even if we restrict our freedom in choosing curves to the dimensionally simpler, yet several choices are still available for the same problem (see, on this point, Bos [1984], p. 345). The precept, in this sense, is not too overrestrictive: this fact gave rise to discussions on the best canon to adopt in order to solve problems in any degree (the core of Bos [1984] is dedicated to such discussions).

⁵⁸Bos [1984], p. 344.

Not only the required equations $F(x, y)$ and $G(x, y)$ are more complicated than the one derived from the problem (namely $H(x)$), because they involve two unknowns, but the inverse elimination problem also admits many (even infinitely many) solutions.

Descartes ventured another plausible ways of dealing with simplicity in geometry in reference to curves and their constructions: one might choose curves that yield an easy ("*facile*") solution. The concept of easiness of solutions is illustrated by the following example, in Book III of *La Géométrie*:

Je ne crois pas, qu'il y ait aucune façon plus facile, pour trouver autant de moyennes proportionnelles, qu'on veut, ny dont la demonstration soit plus evidente, que d'y employer les ligne courbes qui se descrivent par l'instrument XYZ . Car, voulant trouver deux moyennes proportionnelles YA et YE , il ne faut que descrire un cercle dont le diametre soit YE : & pource que ce cercle coupe la courbe AD au point D , YD est l'une des moyennes proportionnelles cherchées. Dont la demonstration se voit à l'oeil, par la seule application de cet instrument sur la ligne YD , car, comme YA ou YB qui lui est egale, est a YC , ainsy YC est a YD , et YD a YE (...) Mais pource que la ligne AD est du second genre, et qu'on peut trouver deux moyennes proportionnelles par les sections coniques, qui sont du premier; & aussy pourcequ'on peut trouver quatre ou six moyennes proportionnelles, par des lignes qui ne sont pas de genre si composés que sont AF & AH , ce seroit une faute en Geometrie que de les y employer. ⁵⁹

In this passage, Descartes presents another construction for the problem of inserting two mean proportionals between segments YA and YE , such that $YA < YE$ (see fig. 4.5.1). Let us draw a circle with diameter YE , and let us next apply to point A a proportions compass (ch. 3, fig. 3.2.1), with opening $YA = a$, which will trace the curve AD . Let us call D the point in which the curve intersects the circle with diameter YE , and let us trace the segment YD . Let a new circle with radius YA and centre Y be traced, such that B the intersection between the circle and the line YD . Let the perpendicular from D to the line YE be drawn, and let the intersection be called C . The segments YC and YD are the sought for mean proportionals.

One can prove the correctness of this construction geometrically, by considering triangles YBC , YCD , YDE (fig. 4.5.1), which are similar by construction. From the similarity

⁵⁹Descartes [1897-1913], vol. 6, p. 442-443.

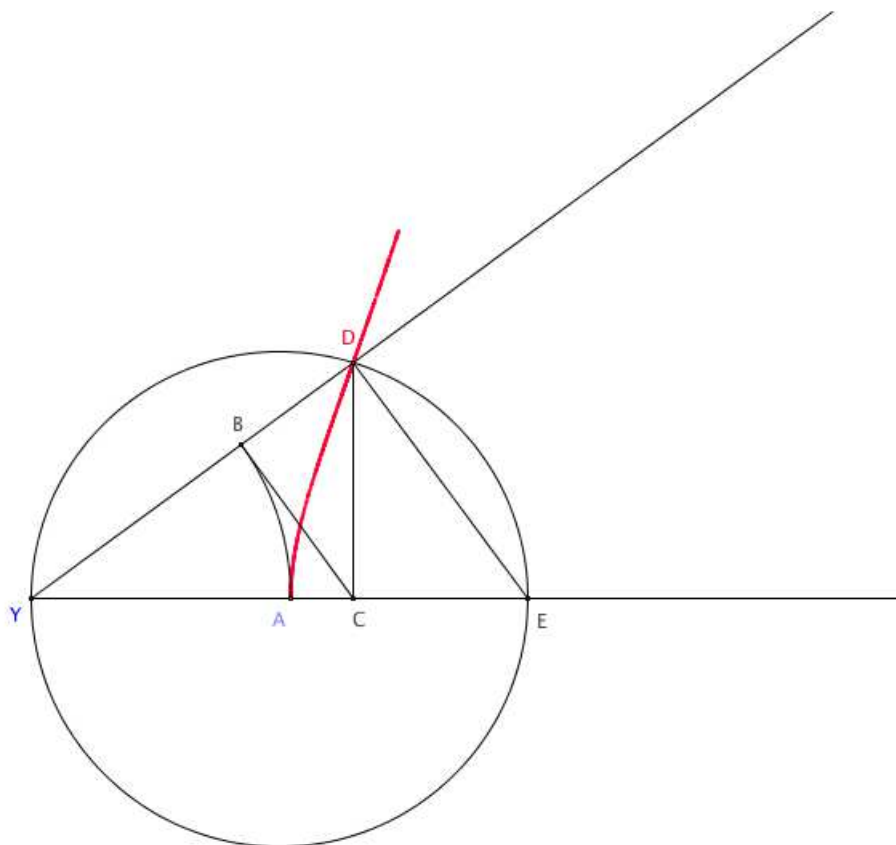

Figure 4.5.1: Insertion of two mean proportionals (easy solution).

of these triangles one can derive the following continuous proportion: $YB : YC = YC : YD = YD : YE$, Since $YB = YA$, segments YC e YD are two sought-for mean proportionals between YA and YE .⁶⁰

The reason why the solution employed by means of a parabola and a circle is considered by Descartes simpler than the solution to the same problem obtained by a curve traced via the proportions compass is obvious, in the light of Descartes' explanations. 'Simplicity', as Descartes disambiguates at the beginning of Book III, is a property that depends on the degree, and consequently on the kind to which a curve belongs. Therefore it is sufficient to compare the curve traced by the proportions compass, on one hand, and the parabola, on the other, in order to decide whether they are of different kinds, and which one among them is simpler. Let us consider, for a start, the curve depicted in fig. 4.5.1. Its equation can be easily determined: if we set angle $BYA = \theta$, $YE = q$, $YA = YB = a$, then $YC = \frac{a}{\cos \theta}$, $YD = \frac{a}{\cos^2 \theta}$, $YE = \frac{a}{\cos^3 \theta} \dots$, point D will lie, by construction, on a curve of polar equation: $a = \rho \cos^2 \theta$ (upon setting $YD = \rho$). This equation can be transformed into a cartesian equation in the unknowns z and y (provided we set: $YC = z$, $DC = y$, and $z^2 + y^2 = \rho^2$), namely: $z^4 = a^2(z^2 + y^2)$. Consequently, the curve traced by point D (in fig. 4.5.1) is a curve of the second kind, hence a curve of higher kind than the conic sections.⁶¹

4.5.2 Easiness, simplicity and the algebraic ordering of curves

The proportions compass is evoked twice in *La Géométrie*. As noted by H. Bos (Bos [2001], p. 358) Descartes' argumentative pattern seems to unfold in a puzzling way for someone who reads *La Géométrie* according to the order of the books. At first, the proportions compass is introduced in book II, in order to offer a paradigmatic instance of a geometric linkage, namely an instrument which contrives the tracing of geometrical curves

⁶⁰Let us recall that Descartes probably devised such a solution, in a purely geometrical way, as early as 1619 (see Bos [2001], p. 239ff.).

⁶¹Let us verify, for the sake of completeness, that the construction of the problem of inserting two mean proportionals by means of the curve traced by a proportions compass complies with the requirement for constructing equations (except, perhaps, for the requirement of simplicity). Let us recall that the problem of inserting two mean proportionals between given segments a and q , is solvable, according to Descartes' protocol, by constructing the corresponding equation: $H(z) = z^3 - a^2q = 0$. It is sufficient to take, for instance, the following couple of equations: $U(z, y) = z^4 - p^2(z^2 + y^2) = 0$, $V(z, y) = z^2 + y^2 - qz = 0$: it is immediate to verify that the original equation $H(z) = 0$ can be found by eliminating the y from both $U(z, y) = z^4 - a^2(z^2 + y^2) = 0$ and $V(z, y) = z^2 + y^2 - qz = 0$. The result, obtained by eliminating y , will then be: $z^4 - a^2qz = z(z^3 - a^2q) = 0$, which proves that the curves associated to equations $U(z, y) = 0$ and $V(z, y) = 0$ can construct the equation. While one recognizes the equation $V(z, y) = 0$ as the equation of a circle, the first equation is satisfied by the curves traced by the proportions compass.

(see chapter 3, section 3.2). Successively, in book III, the same linkage is evoked in order to illustrate the 'easiest' solutions for a (large) class of geometric problems, namely the construction of arbitrarily many means between two given segments. Eventually, though, Descartes subverts the privileged status of the proportions compass, and discards this instrument as an unreliable method to be employed in problem solving, since it introduces a systematic violation of dimensional simplicity.⁶²

Let us observe, firstly, that the use of the proportions compass systematically produces dimensionally too complex (and therefore erroneous) solutions. This phenomenon obtains not only of the problem of inserting two mean proportionals, but of the general problem of inserting an arbitrary number of mean proportionals between given segment: in other words, there is no instance of this problem for which its construction through the application of the proportions compass can trace curves of the lowest possible degree, and thus comply with the requirement of dimensional simplicity.⁶³ Hence, the precise separation between dimensional simplicity and easiness in problem solving reflects into an accurate distinction into two non-overlapping categories of solutions to the generalized problem of inserting n mean proportionals.

However, discarding easy solutions in favour of dimensionally simple ones, at least for what concerns the problem of inserting n mean proportionals, it is not an obviously

⁶²See Bos [2001], p. 358.

⁶³See Descartes [1897-1913], vol. 6, p. 442-443. In Panza [2011], it is proved that: "whatever the positive integer n might be, solving the n mean proportionals problem by relying on a curve traced by a proportions compass does not comply with Descartes's simplicity precept" (Panza [2011], p. 77). For $n > 1$, we distinguish two cases in the problem of inserting n mean proportions between given segments a and q : either n is even, or n is odd. Let us consider the case of inserting an odd number n of mean proportionals (i.e. $n = 2\mu - 1$). For any positive integer μ , the $2\mu - 1$ mean proportionals problem can be reduced to the problem of inserting a single mean proportional and to the problem of inserting $\mu - 1$, and then, by reiteration, either to the single mean proportional problem alone, or to the single mean proportional and to problem of inserting $2m$ mean proportionals, for some positive integer m such that $2m < 2\mu - 1$ (Panza [2011], p. 77). Thus, we need only to consider only the case of $n = 2\mu$ (μ is a positive integer). Let us consider, therefore, the problem of inserting 2μ mean proportionals, whose algebraic analysis yields the equation in the general form: $x^{2\mu+1} = a^{2\mu}q$. The use of the mean proportions compass allows us to construct this equation (and, consequently, the related class of geometric problems) through the intersection of the circle and a curve with equation in the following form: $x^{4\mu} = a^2(x^2 + y^2)^{2\mu-1}$ (the equation of the corresponding curve, for each instance of the problem of inserting an even number of means can be found by relying on the design of the mesolabe). I note that the equation of the solving curve has degree 4μ . On the other hand, it can be proved that for every positive integer μ , there exist curves, with degree less than 4μ , that solve the problem of inserting 2μ mean proportionals. In order to show this, let us consider the equation: $x^{2\mu+1} = a^{2\mu}q$, which expresses the general geometric problem of inserting 2μ mean proportionals. For any positive integer μ , the equation can be obviously constructed by relying on two curves of equations $yx^\mu = a^\mu$ and $a^\mu qy = x^{\mu+1}$, respectively, which clearly belong to a lower class than the curves of equation: $x^{4\mu} = a^2(x^2 + y^2)^{2\mu-1}$, constructed by the proportions compass.

rational choice. Descartes was certainly aware that mathematical procedures leading to easy solutions could possess significant virtues, besides being technically correct. Let us consider, once again, the case of the problem of inserting n mean proportionals. Descartes indulges in praising the curves traced by the proportions compass as offering evident constructions ("*demonstration evidente*"), or constructions that can be seemn 'by the eye' (as we read in *La Géométrie*: "*la demonstration se voit à l'oeil*").⁶⁴

Resuming Descartes' words, I refer to the solutions obtained through the proportions compass as 'perspicuous' solutions. By the quality of 'perspicuity', I refer, for the case of the problem at hand, to the fact that for any number of desired mean proportionals the construction of the corresponding insertion problem can be immediately given, or given in few steps by referring to a single diagram, represented by a certain configuration of the proportions compass (see, for instance fig. 4.5.1 and the corresponding construction in sec. 4.5). Extrapolating from Descartes' account, I can conclude that easiness can be understood as an epistemic or cognitive type of simplicity: a problem solved in an 'easy' way is solved in a way that is transparent to the solver himself, by allowing an immediate grasp of the inferential process leading from the data of the problem to its construction. Hence, there is room to conjecture that Descartes' downplaying of easy solutions to problems, far from being a natural or expected way of proceeding, comes with a cost, since it dismisses evident cognitive and epistemic virtues.

Since easiness should have appeared as a virtue in geometric pursuits, its demise, in favor of a different strategy in problem solving, demands for adequate justification. In contrast, Descartes offered no justification for his choice (as H. Bos recalls, Descartes made "a sudden reversal of direction (...) and ordered, without argument, that nevertheless one should employ curves of lowest possible degree", Bos [2001], p. 358), so that his adamant preference for dimensional simplicity should have appeared puzzling and unjustified to a reader who had followed the linear deployment of the treatise from book I to book III.

But if we consider the developmental history of Descartes' mathematical thought, such a tension between two general strategies in problem solving may conceal a more profound antithesis between two different projects lying behind them, both having to do with the rational ordering of problems and curves in geometry. An interpretation in this direction is prompted by H. Bos (see Bos [2001], p. 359ff.). According to him, the contrast between

⁶⁴Descartes [1897-1913], vol. 6, p. 442-443.

'easiness' and 'simplicity' stages a more fundamental contrast between the standpoint of the "Descartes, author of *La Géométrie*" and of his 'previous self', namely the Descartes 'author' of the letter to Beeckman (1619) and soon later, of the *Cogitationes privatae*. let us recall how Descartes, already in 1619, had sketched the groundwork of a programme in order to solve each problem according to the most adequate solving method (for its illustration, see chapter 3, p. 3.0.2). According to Bos' interpretation, Descartes would have reversed that very programme in *La Géométrie*: whereas he originally structured the edifice of geometry according to a classification of problems on the basis of the type of instrument required for their solutions and their intuitive cogency, in *La Géométrie* he came to privilege algebraic expressions as a means for ordering curves, and, by relying on dimensional simplicity, of ordering problems too.

As Bos suggests, the abandonment of the inchoate project of classifying problems according to the design of the instruments which traced the curve-solutions, like the trisector or the proportions compass, was probably due to the difficulty of generalizing the kinematic approach to problems other than solid ones.⁶⁵ Meanwhile, such abandonment must have involved the retraction of easiness, as the main quality associated to the intuitive cogency of instruments, like the proportions compass, originally developed in the early '20s in order to solve a specific class of problems.

The rationale suggested by Bos can be thus explicated. The preference for dimensional simplicity - and the correlative downplaying of easiness - can be also explained in the backdrop of the programme expounded in the *geometry* of 1637. This was not to be understood, in fact, as a mere catalogue of piecemeal results, but had the aim of classifying problems and curves in a systematical way, imposing strict guidelines on the choice of the solving methods.

Descartes did not fail to grasp that algebra offered clear methodological advantages for the purpose of reaching such a systematical classification. Firstly, he provided unambiguous claims for the preference accorded to the choice of classifying curves on the basis of their degree. We read for instance, in *La Géométrie*:

. . . Je pourrois mettre ici plusieurs moyens pour tracer & concevoir des lignes courbes, qui seroient de plus en plus composées par degré a l'infini, mais pour comprendre ensemble tous celles qui sont en la Nature, & les distinguer par

⁶⁵Bos [1984], p. 359ff.

ordre en certains Genres; je ne sache rien de meilleur que de dire que tous les Poinz, de celles qu'on peut nommer Geometriques (...) ont necessairement quelque rapport a tous les poinz d'une ligne droite, qui peut estre exprimé par quelque equation, et tous par une mesme. . .

Descartes insists, in the passage just quoted, on the conceivability of several methods for tracing the same curve. This theme is repeated elsewhere, in the same work,⁶⁶ underscoring what might have been perceived as a real concern in cartesian geometry, with respect to the problem of classifying curves on the ground of their genesis.

This concern can be explained in a more plain form. Descartes had certainly understood that the compositional nature of geometric linkages allowed one, in principle, to adopt a criterion for ordering curves on purely geometric grounds. For instance, the family of curves traced by a proportions compass can be ordered according to a hierarchy of higher complexity, depending on the number of connected joints which trace a curve, as it is pointed out in *La Géométrie*.⁶⁷

In Descartes' geometry however, and beyond the exemplary case of the proportions compass, it appears difficult to judge the simpler among two competing, although both acceptable constructions of the same curve. This is because several elements can enter the composition of geometric linkages, like already accepted curves (consider, for instance, the circle in the construction of the conchoid, discussed in chapter 3, p. 142 of this study), which increases the difficulty of defining a uniform measure of complexity for them. On the other hand, the determination of the complexity of a curve based on the complexity of linkages would demand to determine the linkage of minimal complexity which can trace it: this is a difficult problem, to my knowledge unsolved.

Hence, I suggest that there is a fundamental reason why an ordering of curves based on the complexity of their genesis might not have been considered a suitable choice in the context of Descartes' geometry. For Descartes, the nature of a curve is determined by its specification by genesis. However, one cannot attribute to a curve, traced according

⁶⁶ Cf., for instance, Descartes [1897-1913], vol. 6, p. 427: "... on pourrait encore trouver une infinité d'autres moyens pour décrire ces mesmes Ouales . . . ".

⁶⁷ Descartes certainly envisaged this possibility, as we can read in Descartes [1897-1913], vol. 6, p. 392: "Or, pendant qu'on ouvre ainsi l'angle XYZ, le point B décrit la ligne AB, qui est un cercle; et les autres points D, F, H, ou sont les intersections des autres regles, décrivent d'autres lignes courbes AD, AF, AH, dont les dernières sont par ordre plus composées que la première, et celleci plus que le cercle". See also ch. 3, sec. 3.2.

to some rule or device, properties that are being predicated of its genesis, if the same curve can be generated through other legitimate procedures, and there are no evident guidelines at disposal in order to limit such a freedom, by preferring one among the various available construction for the same curve.

On the other hand, in the context of cartesian geometry, all points belonging to a geometric curve, or better, their distances (understood as segments) from a fixed axis, are related by one and the same algebraic equation, which describes the curve. And even if one curve may be described by more than one equation (I will present in the following lines two examples of this phenomenon) this situation is by no means analogous to the one occurring about curves and their construction means. Whereas the latter case was characterized by the possibility of associating diverse methods of description to one and the same curve, all the equations that can be associated to one curve share a fundamental property, namely, their degree. We might reformulate this insight by stating that, in cartesian geometry, any curve can be associated to a one degree-invariant family of homogeneous equations in rational, and eventually integer coefficients.

This argument does not rely on obvious premisses, though. Firstly, depending on the choice of the reference axis, different equations may be associated to the same geometric object. This inconvenience can be bypassed by proving (in a slightly anachronistic terminology with respect to the context of *La Géométrie*), that an algebraic equation associated to a curve is degree-invariant under changes of coordinates, namely rotations, translations and changes of the unitary segment. Descartes did not supplement a proof of this statement, or any equivalent proof, but made the following claim: "... encore qu'il y ait beaucoup de choix pour rendre l'équation plus courte, et plus aisée, toutefois, en quelle façon qu'on les prenne, on peut toujours faire que la ligne paraisse de mesme genre, ainsi qu'il est aisé à démontrer" (Descartes [1897-1913], vol. 6, p.), that we may take as an indication that he had foreseen the objection, and did not consider it particularly difficult. Probably Descartes considered that only linear transformations are involved in changes of coordinates, so that invariance of degree may be easily verified.

But Descartes was also aware that the analysis of a problem (either determinate or indeterminate) might result into equations in different degrees, depending on the initial choice of the unknown: in fact he had not set up, in the analysis of a problem, any precise procedure in order to guide the geometer towards the right choice of the unknown. As a significant example in order to illustrate this fact, Descartes evokes a plane *neusis*

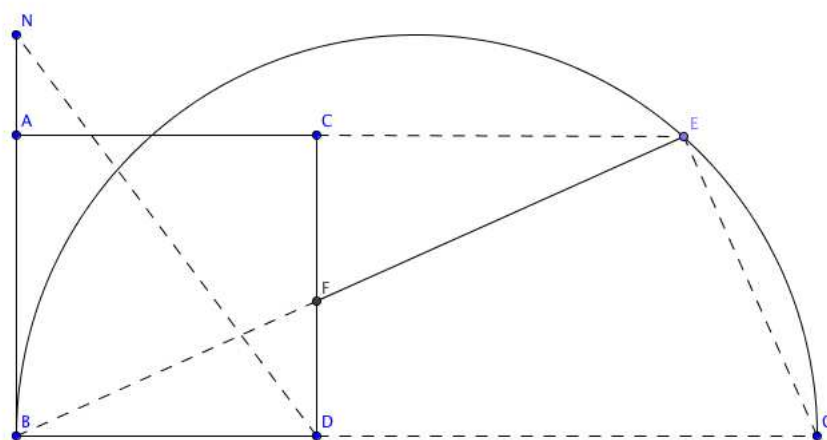

Figure 4.5.2: Heraclides' problem.

problem already solved by Pappus (Descartes [1897-1913], vol. 6, p. 462). This problem can be thus resumed:

Problem (Heraclides). Given a square AD and a line BN , it is required to extend AC to a point E , such that EF , where F is the intersection point between EB and CD is equal to a given segment BN (fig. 4.5.2).

This is - we might say - an 'exemplary example' in Descartes' treatise. Indeed, if we apply the standard cartesian transconfigurational analysis, the most obvious, or natural choice of the unknown will lead to attribute to this problem a solid nature. But this conclusion is false, since the problem at hand is a plane *neusis* problem, as correctly proved by Pappus.⁶⁸

Let us examine in detail Descartes' reasoning. Descartes remarks that the most 'natural' way of proceeding, according to his canon of analysis, is the following:

- Choose segment $DF = x$ as unknown.
- Let then $CD = BD = a$; $EF = c$; $CF = a - x$.

⁶⁸Cf. Pappus [1986], p. 202-205.

- Since $CF : EF = DD : BF$ (triangles CEF and BDF are similar by construction), we will have that $BF = \frac{cx}{a-x}$. Then, by Pythagoras's theorem: $FD^2 + BD^2 = BF^2$, or $a^2 + x^2 = (\frac{cx}{a-x})^2$.
- A little manipulation leads to the following equation in the fourth degree:

$$x^4 - 2ax^3 + (2a^2 - c^2)x^2 - 2a^3x + a^4 = 0 \quad (4.5.1)$$

Other choices of the unknown, for instance when $BF = x$ or $CE = x$, will also lead to equations in the fourth degree, namely: $x^4 + 2cx^3 + x^2(c^2 - 2a^2) - 2a^2cx - a^2c^2 = 0$ or $x^4 + 2ax^3 + 2a^2x^2 - x^2c^2 - 2axc^2 - a^2c^2 = 0$, respectively.⁶⁹

Since the equation obtained is of the fourth degree, the sole application of the canon of construction deployed in Descartes' geometry would prescribe, for this problem, a construction by a parabola and a circle: therefore the problem will be solid.

Descartes was also aware that the problem could be constructed by ruler and compass. Astutely, he reported only the construction by plane means, as given by Pappus in the synthesis of the problem (Descartes [1897-1913], vol. 6, p. 462; Pappus, *Collection*, VII, prop. 72, Pappus [1986], p. 202ff.):

- Let extend segment BD until point G , such that $DG = DN$.⁷⁰
- Let a circle be drawn, with diameter BG .
- Let us extend AC , and mark as E the intersection point between this line and the circle.
- Let us join E and B : we shall have $EF = BN$, therefore the segment EF will solve the problem.

The proof, omitted from *La Géométrie*, is given in Pappus' *Collection*, instead (Pappus, *Collection*, VII, prop. 72; Pappus [1986], p. 202-204. I refer, for a modern paraphrase, to: Bos [2001], p. 394, 395).

⁶⁹See Descartes [1897-1913], vol. 6, p. 462.

⁷⁰I have reported the auxiliary constructions with dotted lines in fig. 4.5.2.

Proof. Since $DG = DN$ by construction, we derive: $sq(DG) = sq(DN) = sq(BN) + sq(BD)$ (*).⁷¹ Let the semicircle built on BG as diameter be traced. The segment DG is greater than DC (indeed: $DH = DN > BD = DC$), therefore point C will fall in the circle with diameter BG . From E , intersection point between AC extended and the semicircumference on BG , let us trace segments EB and EG . Pappus invokes, at this point of the proof, the following lemma, proved in a previous proposition: $sq(CD) + sq(EF) = sq(DG)$ (**).⁷² By equating (*) and (**) we obtain: $sq(BN) + sq(BD) = sq(CD) + sq(EF)$. Since $BD = CD$, $sq(CD) = sq(BD)$, whence: $sq(BN) = sq(EF)$. Since the squares built on BN and EF are equal between them, so segments BN and EF will be equal too.

I point out that Descartes did not seem so much interested in giving a justification of the above construction, but on stressing the difficulty of its discovery. On this concern he remarked: "Pour ceux qui ne sçauroient point cette construction, elle seroit assez difficile à rencontrer, & en la cherchant par la methode icy proposée, ils ne s'aviseroient jamais de prendre DG pour la quantité inconnüe, mais plutost CF ou FD , a cause que ce sont elles qui conduisent plus aysement a l'Equation".⁷³

In fact, starting from the construction offered by Pappus, one can associate to the problem a quadratic equation: it is sufficient to set $CD = BD = a$, $DG = x$, $BN = c$, Descartes remarks, in order to obtain the second-degree equation: $x^2 - a^2 - c^2 = 0$. The problem will be constructable by ruler and compass, the required *neusis* will be therefore plane, as the ancients had correctly stated.⁷⁴

I observe, as a start, that the quadratic equation can be derived in a straightforward way from the configuration described in fig. 4.5.2, in virtue of the equality: $sq(DG) = sq(BN) + sq(BD)$. But even if the problem can be effectively reduced to a quadratic equation, setting $DG = x$ is considered by Descartes a somewhat unnatural choice of the unknown. The segment DG , in fact, is not evoked in the protasis of the problem, nor does it immediately pops up in the resulting configuration. In order to make DG available, in fact, an auxiliary construction is required, which, as Descartes emphasized, "is difficult to find". I point out, moreover, that Descartes omits to report, in his narration, Pappus'

⁷¹The notation: ' $sq(a)$ ' denotes the square built on the segment a .

⁷²Cf. Collection VII, prop. 71. See Pappus [1986], p. 202.

⁷³Descartes [1897-1913], vol. 6, p. 462.

⁷⁴Descartes [1897-1913], vol. 6, p. 463.

analysis of the problem.⁷⁵ In this way, a reader can gain an even stronger impression that the auxiliary construction producing DG appears out of nothing, and that the most obvious way of performing an analysis of the problem will be to reduce it to a quartic equation (like eq. 4.5.1).

Conclusively, the example of Pappus' *neusis* problem can be seen to undermine the cogency of the algebraic ordering of problems and curves: according to Descartes' canon of problem-solving, in fact, a fourth degree equation requires a parabola and a circle, whereas a quadratic equation requires the employment of the ruler and compass only (or a straight line and a circle).

Descartes probably was aware of other occurrences of a similar phenomenon,⁷⁶ but the problem of Heraclides, discussed in *La Géométrie*, was well-known among early modern mathematicians.⁷⁷

How to prevent that a particular choice of the unknown might lead to associate to the same problem equations in different degrees, and ultimately make us attribute the wrong level to a certain problem?

Descartes partially made up to such a freedom connected to the choice of the unknown, by giving clear and exhaustive (in his view) directions in order to check the reducibility of an equation obtained at the end of the process of analysis.⁷⁸

Let us point out that the notion of reducibility here at stake differs from those that I have sketched in note 15. The concept of reducibility I would like to examine in this context concerns in fact the possibility of factoring a polynomial $H(x)$, in one variable, appearing in an equation $H(x) = 0$ associated to a geometric problem, into the product of two factors, $U(x)$ and $V(x)$ that are polynomials of degree at least one, and whose coefficients can be constructed by ruler and compass from the coefficients of the original equation. If such a reduction is possible, then the roots of the equation $H(x) = V(x) \cdot U(x) = 0$

⁷⁵Cf. Pappus [1986], p. 202.

⁷⁶Another instance is discussed in van Schooten's Commentary to the first latin edition of the *Géométrie*, and it is reproduced in the second (Descartes [1659-1661], vol. 1, p. 317).

⁷⁷See Brigaglia and P. [1986].

⁷⁸As Descartes emphatically noted the *neusis* problem was instructive: "pour (...) avertir que, lorsque le Probleme proposé n'est point solide, si en le cherchant par un chemin on vient a une Equation fort composée, on peut ordinairement venir a une plus simple, en le cherchant par un autre" (Descartes [1897-1913], vol. 6, p. 463).

will be roots either of $V(x)$ or of $U(x)$, both of degree less than the degree of $H(x)$, so that it will be sufficient to construct either one of these factors in order to construct the original equation.

Descartes worked out a theory of reducibility of equations in the form of a series of techniques with examples.⁷⁹ Although these rules of reducibility are conceived, in principle, so general that they apply to any polynomial equation,⁸⁰ Descartes discussed in detail only the reducibility for the case of the cubics and quartic polynomial equations in one variable.

Hence, if we are given a cubic equation $H(x) = 0$, in a monic polynomial $H(x)$, and whose coefficients belong to the ring $\mathbb{Z}[a, b, c, \dots]$, Descartes asks to search for an integer divisor a of the constant term of $H(x)$, and then divide $H(x)$ by a linear factor $(x \pm a)$.⁸¹ If the test is successful, then the polynomial $H(x)$ will be divided by a linear factor $(x \pm a)$ with no remainder. We will have therefore: $H(x) = (x \pm a)U(x) = 0$, for some polynomial $U(x)$ in the second degree. The equation $H(x) = 0$ will be constructible by ruler and compass, and the original geometric problem is plane. If, on the contrary, the test is not successful, then the equation will be judged irreducible, and the original geometric problem will be a solid one.⁸²

The same procedure can be applied in the case of a quartic equation, and to the cubic polynomial that may result from a first division. The procedure continues until we obtain an irreducible cubic factor, or a quadratic factor.

In the case of a fourth-degree equation, Descartes devised a more complex method in order to check whether the equation could be decomposed into two quadratic factors. In illustrating Descartes' way of proceeding, I will follow the interpretations offered by Galuzzi and Rovelli [1996], in order to explicate those points (sometimes crucial in order

⁷⁹The following presentation is particularly indebted to Galuzzi and Rovelli [1996].

⁸⁰Descartes was confident that these rules were infallible, and could be applied to higher degree equations: "je pourrais aussy en adiouter d'autres - explains Descartes, referring to rules for the reducibility of equations - pour les equations qui montent jusqu'au sursolide, ou au quarré de cube, ou au delà. . ." (Descartes [1897-1913], vol. 6, p. 463-464).

⁸¹Descartes [1897-1913], vol. 6, p. 454, 455 (continuing from the quotation in the previous note): "... puis, en examinant par ordre toutes les quantités qui peuvent diviser sans fraction le dernier terme, il faut voir si quelqu'une d'elles, jointe a la quantité inconnüe par le signe + ou -, peut composer un binome qui divise toute la Somme". I note that Descartes grounded this procedure on the tacit rule that any rational root of an equation is a factor of the constant term.

⁸²Descartes [1897-1913], vol. 6, p. 456-457.

to understand Descartes' reasoning) left implicit in the text of *La Géométrie*. Briefly speaking, given an equation in the form (with $p, q, r \in \mathbb{Z}[a, b, c \dots]$, and $q \neq 0$):⁸³

$$P(x) = x^4 + px^2 + qx + r = 0$$

in which the second term in degree three is eliminated, thanks to a rule previously specified in Descartes [1897-1913] (vol. 6, p. 449), we can still search for the divisors of the known term. If, for instance, α is such a divisor, then $P(x)$ can be factored in the product: $(x - \alpha)f(x)$, where $f(x)$ is a third degree polynomial. The same procedure can be applied by searching whether $f(x)$ can be factored into the product of a quadratic and a linear factor.

But it can also happen that the polynomial $P(x)$ cannot be factored simply by searching the divisors of the known term. In this case, we can still ask (with Descartes) whether $P(x)$ may be factored in the following way:⁸⁴

$$P(x) = x^4 + px^2 + qx + r = (x^2 + \alpha x + \beta)(x^2 - \alpha x + \gamma) = 0.$$

From the above equality and by comparing the coefficients α , β and γ , left undetermined, the following system can be set up:

$$\begin{cases} \beta + \gamma = p + \alpha^2 \\ \beta - \gamma = -\frac{q}{\alpha} \\ \beta\gamma = r \end{cases}$$

⁸³See also: Vuillemin [1987] (p. 163), Bos [2001] (p. 391-392) and Lützen [2010] (p. 16-17).

⁸⁴The method I will sketch in the subsequent lines corresponds to a plausible pattern of discovery followed by Descartes, which is explicated, however, not in *La Géométrie*, but in van Schooten's Commentary. On the ground of Schooten's and Hudde's explanation it will become current to interpret Descartes' reducibility of a quartic in these terms: "la méthode de Descartes - so Lagrange notes in his *Leçons élémentaires* - qu'on suit communément dans les éléments de l'Algèbre (...) consiste à supposer immédiatement que la proposée soit produite par la multiplication de deux équations du second degré" (in Vuillemin [1987], p. 161).

The first two equations form a linear system in β and γ , so that $\gamma = \frac{1}{2}(\alpha^2 + p\alpha + \frac{q}{\alpha})$, and $\beta = \frac{1}{2}(p + a^2 - \frac{q}{\alpha})$. By taking into account the third equation, $\beta\gamma = r$, we will have:

$$\alpha^6 + 2p\alpha^4 + (p^2 - 4r)\alpha^2 - q^2 = r. \quad (4.5.2)$$

By setting $r = 0$, this equation can be considered, as stressed in Vuillemin [1987] (p. 163), a sixth degree 'resolvent' associated with the original quartic. But substituting with: $\alpha^2 = y$, we obtain a third degree equation instead: $Q(y) = y^3 + 2py^2 + (p^2 - 4r)y - q^2 = 0$. The 4.5.2 can be therefore considered a cubic resolvent of our original equation $P(x) = 0$. In fact, if y_i is a root of the 4.5.2, then $P(x) = 0$ can be factored into the following product:

$$P(x) = (x^2 - y_i x + \frac{1}{2}y_i^2 + \frac{1}{2}p + \frac{q}{2y_i})(x^2 + y_i x + \frac{1}{2}y_i^2 + \frac{1}{2}p - \frac{q}{2y_i}) = 0. \quad (4.5.3)$$

Hence, if the equation $Q(y) = 0$ can be divided by a binomial factor (this factorization can be performed by searching the divisors of the constant term q^2 , following the rules prescribed above), it will have a real root y_i constructable by ruler and compass. In this case, each factor in which $P(x)$ has been divided is a quadratic one, in the unknown x and in the coefficient y_i , constructable by ruler and compass. $P(x) = 0$ will be therefore constructable by ruler and compass too, and the associated problem will be plane. If the cubic resolvent cannot be factorized, on the other hand, the equation will not be decomposable into quadratic ones, and the associated problem will be a solid problem.⁸⁵

Descartes applied these rules precisely to the case of the fourth-degree equation obtained from the analysis of Pappus' *neusis* problem, and succeeded in decomposing that equation into the product of two quadratic factors.⁸⁶ He thus managed to express segment DF (fig. 4.5.2) as:

$$DF = \sqrt{\frac{1}{4}a^2 + \frac{1}{4}c^2} - \sqrt{\frac{1}{4}c^2 - \frac{1}{2}a^2 + \frac{1}{2}a\sqrt{a^2 + c^2}}.$$

⁸⁵Descartes' proof of the reducibility of the fourth degree equation connected with the problem of Heraclides, discussed above, can be interpreted, with the benefit of hindsight, as a strategy for checking the factorization of a polynomial over a field obtained by the adjunction of square roots (see Galuzzi [2010], p. 538).

⁸⁶See Descartes [1897-1913], vol. 6, p. 462-463.

Since this expression contains only square roots, Descartes could conclude that DF would be constructable by ruler and compass, and the corresponding *neusis* problem solvable by plane means, just like the ancients had claimed (it is in fact sufficient to determine point F in order to solve the *neusis* problem).

Virtues and limitations of Descartes' techniques of factorization have been analyzed through the lense of modern mathematics in a number of recent studies.⁸⁷

It is important to underline, with respect to the theme discussed in this chapter, that Descartes' belief that his rules for reducibility was certain and 'infallible' is partially justified in the light of the examples treated in the Book. Indeed, at least for the simplest cases (namely, third and fourth degree equations discussed in Book III of *La Géométrie*) Descartes' reducibility techniques can be envisaged as representing an 'effective method', namely: "a method for computing the answer [to a problem] that, if followed necessary and as far as it may be necessary, is logically bound to give the right answer (and no wrong answers) in a finite number of steps" (in Hunter [1973], p. 14) in order to decide whether a problem leading to fourth or third degree equations with coefficients in $\mathbb{Z}[a, b, c, \dots]$ can be further factored, and therefore whether it corresponds to a solid or a plane problem. On this ground, Descartes prescribed the guidelines of a more general method for reducibility, that could be virtually applied to equations in any degree:

Lorsque on a tasché de les reduire [namely, the equations] a mesme forme que celles, d'autant de dimensions, qui viennent de la multiplication de deux autres qui en ont moins, & qu'ayant denombé tous les moyens par lesquels cette multiplication est possible, la chose n'a pû succeder par aucun, on doit s'assurer qu'elles ne sçaroient estre reduites a de plus simples. En sorte que, si la quantité inconnuë a 3 ou 4 dimensions, le Probleme, pour lequel on la cherche, est solide; et si elle en a 5 ou 6, il est d'un degré plus composé, et ainsy des autres.⁸⁸

⁸⁷Among the numerous studies, I refer in particular to the following ones: Vuillemin [1987], p. 154ff., Galuzzi and Rovelli [1996], Bos [2001] (especially p. 391ff.), Lützen [2010], p. 16-18.

⁸⁸Descartes [1897-1913], vol. 6, p. 464.

The procedure here described can be thus paraphrased: let us suppose that we want to evaluate whether an algebraic equation $P(x) = 0$, of degree higher than 2 is reducible.⁸⁹ Then we must consider all the finitely many integer divisors of the known term (provided this can be done: Descartes takes this point for granted), and check whether it exists a divisor α such that: $P(x) = (x \pm \alpha)Q(x)$, where $Q(x)$ will have degree smaller than the degree of $P(x)$. If the polynomial $Q(x)$ has degree 2, then the procedure terminates here: the equation is a quadratic one, and the corresponding problem will be plane. If $Q(x)$ has degree higher than 2, the same factorization procedure can be applied to this polynomial, until we factor it into the product of an irreducible polynomial of degree higher than 2, or into the product of a quadratic factor, and finitely many linear factors.

I note that Descartes never required that quadratic factors should be decomposed into the product of linear binomials, even when this could be done over the ring $\mathbb{Z}[a, b, c \dots]$. This restriction underscores that the motivations behind the techniques of reducibility expounded in *La Géométrie* remained geometrical: in the context of Book III, Descartes was primarily interested in the reducibility of equations in order to determine whether an apparently solid problem was in fact plane, and thus avoid the error of solving it by overcomplicated methods.

Descartes omitted the details of this general procedure, leaving the task to perform the required demonstrations to the intelligence of the reader. This does not appear as an easy task, but such moves consisting in leaving on the shoulder of the readers the burden of completing the demonstrations are a characteristic of Descartes' style. At any rate, the core of the techniques of reducibility expounded in *La Géométrie* is partially justified, with the benefit of hindsight, in the light of today treatments, which recast and improve Descartes' inchoate procedures with the aid of tools essentially extraneous to cartesian mathematics.⁹⁰

However, Descartes' technique for the decomposition of equations also presents open issues. Let us consider, for instance, the equation 4.5.3: in this case, the polynomial $P(x)$ is factored into two quadratic factors in which the coefficient y_i are constructable by ruler and compass from the coefficients of the original quartic equation. In a slightly anachronistic terminology, we can say that the quartic polynomials considered by Descartes are

⁸⁹Let us recall that $P(x)$ is a monic polynomial, whose coefficients can be generally considered in the ring $\mathbb{Z}[a, b, c, \dots]$, and a, b, c, \dots are finitely many quantities, given of the original problem.

⁹⁰For polynomials in one variable, see Childs [2008], ch. 13.

not factored over the ring $\mathbb{Z}[a, b, c, \dots]$ but over another structure, obtained, in modern parlance, by the adjunction of quadratic irrationals to the field of the rational quantities. But the very possibility of unique factorization of polynomials in this new structure is an open question, though, as underlined in Bos [2001] (p. 391), and in Lützen [2010] (p. 18).

Given this premiss, the meaning of reducibility becomes unclear, at least in the context of the decomposition of quartic polynomials over the field obtained by the adjunction of quadratic irrationals. Therefore, the effectiveness of Descartes' technique of reducibility is also undermined. These considerations alert us against taking Descartes' method of reducibility as an effective method, since, in so far the notion of reducibility is not clearly defined, the method is not logically bound to always give the right answer.

Let us now resume the main tenets of Descartes' interpretation of simplicity in relation with problem solving. In this and the previous chapters I have endeavoured to show that Descartes' long-term program, whose first formulation can be retrieved in the 1619 letter to Beeckman, and whose mature accomplished is to be found in *La Géométrie*, aimed to provide a method by which all problems of geometry could be solved, each by the most adequate means.

A central methodological role in this project was played by Pappus' precept, according to which it is a sin (in Commandinus' translation: "*peccatum*") to solve a problem through an inappropriate genre of curves. In *La Géométrie*, *simplicity* is the key word in order to understand Descartes' interpretation of the Pappusian requirement: geometers should always choose the most appropriate curves for a problem by avoiding committing the errors ("*fautes*") of using too simple and too complex solutions.

Since simplicity is primarily measured by the algebraic equations associated to curves, the latter becomes the key resource in order to secure knowledge about the solution of a problem, or, we may say, about its 'nature'.

Descartes' reliance on equations as a privileged means in order to denote and order curves and, consequently, as a means for choosing the most geometrical solution of problems too, can be motivated on the backdrop of different measures of simplicity, certainly available to Descartes, like the measure dictated by the constitution of the linkages employed for the construction of a curve. As I have related in chapter 3, the compositional nature

of linkages could offered a criterion for ordering curves, according to the complexity of their tracing devices. But the possibility of associating to a certain curve a particular tracing procedure is not sufficient, in the context of *La Géométrie*, in order to exclude that simpler combinations of linkages might be found, for the same curve.

In fact, there was no available method either to Descartes or to his contemporaries, in order to assess the minimal number of linkages necessary and sufficient for tracing a curve.⁹¹ On the contrary, as I have illustrated in the previous section, Descartes' techniques of reducibility offered, in principle, a quasi-algorithmic method (at least in Descartes' mind) in order to associate any curve to one and the same class of degree invariant equations.

The very existence of an effective procedure (at least in Descartes' view) in order to associate any geometric curve to a class of irreducible equations, in the same degree (that is also the lowest possible degree for the curve at hand) probably made, or contributed to make algebraic equations a preferred modality of reference in order to give information on a curve as such, rather than on the mechanisms for its construction.

Reducibility techniques could be also applied to equations associated to problems. Indeed, as I have illustrated in the previous section, equations allowed the geometer to extract information on the nature of problems, namely, information on their constructibility. This point is clearly resumed in Van Schooten's summary of Book III of Descartes' *Géométrie*:

Postquam igitur ea, quae ad aequationum recognitionem ac emendationem pertinent, exposita sunt, et quidem ex aequationum cognitione (...) dependeat quoque problematum cognitio, ac prout aequatio est vel Quadrata, vel Cubica ... Problema, quod ad ipsam reducitur, dicatur vel Planum vel Solidum (...) illudque exinde construi queat vel per rectas lineas et circulos, vel per Sectiones Conicas.⁹²

⁹¹Nor I do know of the existence of such methods, even today.

⁹²Descartes [1659-1661], vol. 1, p. 279: "Hence, after that all that concerns with the understanding and amendment of equations have been expounded, and after it has been expounded that the knowledge of the problems depends on the knowledge of equations too, and accordingly the equation is either Quadratic, or Cubic (...) the Problem, to which it can be reduced, will be said Plane or Solid (...) and it will be constructible thereby either through straight lines and circles, or through conic sections."

As we can evince from Van Schooten's remarks, which paraphrase, in their turn, the programme deployed by Descartes in the central part of Book III, the 'knowledge of a problem', i.e. of its nature, depends on the knowledge of the (irreducible) equation obtained as the end result of its analysis. Descartes judged it would be sufficient, on the ground of the rule of simplicity established by Descartes, to know the degree of the equation associated to a certain problem, in order to choose the simplest solving curves, and therefore determine the plane, solid or linear nature of the former. This dictated a hierarchical organization of geometric problems based on their constructional complexity, although only the plane/solid divide is probed along broad lines in the *La Géométrie*.

4.6 Impossibility and the interpretation of Pappus' norm

4.6.1 Impossibility arguments in *La Géométrie*

A crucial question for the completion of Descartes' programme remains to be answered: on which grounds are we entitled to claim, when the end result of the analysis of a problem is an equation of a certain degree, constructible by prescribed means according to Descartes' protocol, that the same equation cannot be constructed by other, simpler curves?

Descartes did tackle the question explicitly, in the final sections of Book III:

Il est vray que je n'ay pas encore dit sur quelle raison je me fonde, pour oser ainsy assurer si une chose est possible, ou ne l'est pas. Mais, si on prend garde comment, par la methode dont ie me sers, tout ce qui tombe sur la consideration des Geometres, se reduit a un mesme genre de Problemes, qui est de chercher la valeur des racines de quelque Equation, on iugera bien qu'il n'est pas malaysé de faire un denombrement de toutes les voyes par lesquelles on les peut trouver, qui soit suffisant pour demonstrier qu'on a choisi la plus generale et la plus simple.⁹³

And added on these general remarks a fully synthetic impossibility argument, with the purpose of showing why a solid problem cannot be solved by "plane" means, instead:

Et particulierement pour ce qui est des Problemes Solides, que j'ay dit ne pouvoir estre construits sans qu'on y employe quelque ligne plus composée que

⁹³Descartes [1897-1913], vol. 6, p. 475.

la circulaire, c'est chose qu'on peut assez trouver, de ce qu'ils se reduisent à deux constructions; en l'une desquelles il faut avoir tous ensemble deux points, qui determinent deux moyennes proportionnelles entre deux lignes données, & en l'autre les deux points, qui divisent en trois parties esgales un arc donné: Car d'autant que la courbure du cercle ne depend, que d'un simple rapport de toutes ses parties, au point qui en est le centre, on ne peut aussy s'en servir qu' a determiner un seul point entre deux extremes, comme a trouver une moyenne proportionnelle entre deux lignes droites données, ou diviser en deux un arc donné, au lieu que la courbure des sections coniques, dependant toujours de deux diverses choses, peut aussy servir a determiner deux points differents.⁹⁴

Descartes generalized the same argumentative scheme to problems of "one degree higher than solids", "... et qui presupposent l'invention de quatre moyennes proportionnelles, ou la division d'un angle en cinq parties esgales",⁹⁵ in order to prove that these problems cannot be solved by conic sections, but require higher curves, like the cartesian parabola.⁹⁶

Descartes' impossibility argument has been viewed as "the earliest attempt to prove or explain the impossibility of constructing certain problems (such as the trisection of the angle) with certain means (such as straight lines and circles)".⁹⁷ This judgement might be not wholly correct, though. As remarked by J. V. Field: "a very early example of an attempt to prove that a construction is impossible" is represented by Kepler's attempt, in the *Harmonices mundi libri V* (1619) to prove, in a merely geometric way, that a regular heptagon cannot be constructed by ruler and compass.⁹⁸

Nevertheless, Descartes was probably the first to have ventured an argument that the angle cannot be trisected by plane means.⁹⁹ Because of the entanglement between algebraic and geometric reasoning in Descartes' argument, its structure is certainly remarking, and it is worth being examined.

⁹⁴Descartes [1897-1913], vol. 6, p. 475-476.

⁹⁵Descartes [1897-1913], vol. 6, p. 476.

⁹⁶"La ligne courbe qui se décrit par l'intersection d'une Parabole et d'une ligne droite (...) car j'ose assurer qu'il n'y a de plus simple en la nature, qui puisse servir a ce mesme effet", *ibid.*

⁹⁷Bos [2001], p. 380.

⁹⁸Field [1994], p. 226.

⁹⁹As observed by J. V. Field, Kepler probably shared the view of many of his contemporaries, according to which the trisection was an unsolved problem, although it was unknown whether it was an unsolvable one (see Field [1994], p. 226).

As reported in the above passages, Descartes introduced his reflections on impossibility by general considerations concerning the construction of equations: "il n'est pas malaysé de faire un denombrement de toutes les voyes par lesquelles on les peut trouver, qui soit suffisant pour demonstrier qu'on a choisi la plus generale et la plus simple". But when Descartes examined the case of solid problems, he did not seem to follow the approach just sketched, and offered a quite different argument, that can be resumed in three steps:

1. If a problem - Descartes argues - is reducible to a fourth or third degree equation (Descartes employed the expression: "Problesmes Solides" in order to refer, I suppose, to such problems), it can be constructed either by solving the problem of trisecting an angle (plus auxiliary ruler and compass constructions), or by solving the trisection problem (plus auxiliary ruler and compass constructions).
2. The problems of inserting two mean proportionals between two segments and of trisecting an angle are unsolvable by ruler and compass.
3. Therefore, problems reducible to fourth and third degree equations cannot be constructed by ruler and compass only.

The first claim, according to which any solid problem can be reduced either to the problem of inserting two mean proportionals or to the problem of trisecting a given angle, is crucial for the structure of Descartes' impossibility argument, and it is proved, relying on algebra. Indeed, as Descartes observed in Book III, one could show that all solid problems are reducible to the insertion of two mean proportionals between given segments, or to the problem of trisecting an angle (or the corresponding arc), by an algebraic reasoning:

En considerant que leur difficulté peuvent toujours estre comprises en des Equations qui ne montent que iusques au quarré de quarré ou au cube; et que toutes celles qui montent au quarré du quarré se reduisent au quarré, par le moyen de quelques autres qui ne montent que iusques au cube, et enfin qu'on peut oster le second terme de celles cy.¹⁰⁰

This result, let us recall, had been already proved by Viète in the *Supplementum Geometriae* (1593), though. Descartes did not give any credit to his predecessor, and offered a new argument, along the following lines. Since quartic equations can be reduced to quadratic ones by means of cubic resolvents, Descartes could restrict his scope to the

¹⁰⁰Descartes [1897-1913], vol. 6, p. 471.

exam of the sole cubic equations, that he reduced to the following cases by applying standard rules of transformation:¹⁰¹

$$z^3 = px + q;$$

$$z^3 = px - q;$$

$$z^3 = -px + q.$$

For the sake of conciseness, we can set: $|P| = p$ and $|Q| = q$, and conclude that any cubic equation can be written, ultimately, as: $z^3 = Px + Q$.

The exam of the discriminant led Descartes to distinguish two situations: either $(\frac{Q}{2})^2 > (\frac{P}{3})^3$ or $(\frac{Q}{2})^2 < (\frac{P}{3})^3$. In the former case, the unknown could be expressed by a rule "attributed by Cardan to a certain Scipio Ferreus":

$$z = \sqrt[3]{\frac{Q}{2} + \sqrt{(\frac{Q}{2})^2 - (\frac{P}{3})^3}} + \sqrt[3]{\frac{Q}{2} - \sqrt{(\frac{Q}{2})^2 - (\frac{P}{3})^3}}$$

As, by hypothesis, we have that: $(\frac{Q}{2})^2 > (\frac{P}{3})^3$, the unknown z can be found by determining a cubic root, or by constructing two mean proportionals between 1 and the known quantities appearing under the cubic root signs in the formula above.¹⁰²

On the contrary, the case corresponding to: $(\frac{Q}{2})^2 < (\frac{P}{3})^3$ represents the so-called *casus irreducibilis*, because it involves uninterpretable square roots of negative quantities. In this case, Descartes proved, by giving the construction, that the problem could be reduced to the trisection of an angle.¹⁰³

¹⁰¹A fourth case, namely: $z^3 = -px - q$ is not discussed by Descartes. The reason, according to Bos, is that Descartes: "implicitly assumed that at least one solution was positive" (Bos [2001], p. 377).

¹⁰²Descartes [1897-1913], vol. 6, p. 472.

¹⁰³Descartes [1897-1913], vol. 6, p. 474-475.

Ultimately, the examination of the cases in which $(\frac{Q}{2})^2 > (\frac{P}{3})^3$ and in which $(\frac{Q}{2})^2 < (\frac{P}{3})^3$ allowed Descartes to conclude that any solid problem (in this case, any problem reducible to a cubic equation) can be reduced either to the geometric problem of the insertion of two mean proportionals, or to the trisection of an angle. On these grounds, Descartes could infer that it was sufficient to prove that either the problem of inserting two mean proportionals or the trisection problem cannot be constructed by plane means, in order to prove that any problem reducible to quartic or cubic equations is unsolvable that way.

But the argument deployed in *La Géométrie* in order to prove the unsolvability of the trisection and the insertion of two mean proportionals (see above: Descartes [1897-1913], vol. 6, p. 475-476) is not perspicuous. I shall try to disentangle it here, following Descartes' narration as closely as possible:

1. Since the curvature of the circle depends on one 'simple relation' (to be understood as the distance to the center of all the points on the circumference), this curve can be used to construct at most one point between the extremes of a segment or arc. Since the curvature of a conic section (namely a Parabola, an Hyperbola, or an Ellipse) depends on two "things" or relations, it can be employed in order to determine at most two points between two (given) extremities.
2. The problem of bisecting an angle or of finding one mean proportional demands the construction of one point only, whereas the problem of trisecting an angle or of finding two mean proportionals between two given segments requires the determination of two points.
3. Hence, circles alone, or circles and straight lines, cannot be employed to solve either the trisection problem or the problem of inserting two mean proportionals, because in order to construct them it is required to determine at most two points between two given extremities.

The point 1 above can be followed as far as it establishes that the curvature of a circle is constant and depends on the distance of each point on the circumference from the centre. The generalization to conic sections is less evident, though, probably because Descartes' notion of curvature is barely analyzed in *La Géométrie*, and remains treated on a mere intuitive level. At any rate, I will follow H. Bos' suggestion, according to which: "Probably Descartes had focal properties in mind when he wrote about the two 'things' ('*choses*') involved in the curvature of conics as opposed to the single relation (to

the center) involved in the curvature of a circle. One may say that he saw the variability of the curvature as the essential feature that determined the power of curves in solving problems".¹⁰⁴

Even on the ground of this explanation, though, it is difficult to see how this qualitative distinction relates to the possible use of curves in solving the problems of a certain class. Descartes' remark reported in point 2 might be tentatively explained in this way: in order to construct the bisection of a given angle it is sufficient, according to a simple euclidean construction (it can be found proposition I, 9 of the *Elements*), to determine one point only on the bisectrix of the angle. Moreover, in order to insert one mean proportional between two given segments, we can rely on proposition VI, 13 of Euclid's *Elements* (also evoked in Book I of *La Géométrie*), so that it will be sufficient, again to construct one point in order to solve the problem.¹⁰⁵

On the other hand, by claiming that the trisection of an angle or an arc is solved by the finding of two points between two extremes, Descartes was probably referring to one of the previous sections of *La Géométrie*, where he had discussed the trisection problem (in particular to the diagram reproduced in Descartes [1897-1913], vol. 6, p. 470, fig. 4.6.1 below), where points Q and T are inserted between the extremities N and P , so that the angle $N\hat{O}Q$ is one third of the angle $N\hat{O}P$. It is less clear how to understand the reference to the problem of inserting two mean proportionals: Descartes might be referring to the construction of the couple of points O and T (in fig. 4.4.2 above) or points C and D (with respect to the construction by the proportions compass, in fig. 4.5.1).

However, it is by no means clear why, on this ground, the sole circles (or circles and straight lines coupled together) cannot be successfully employed for solving solid problems. Actually, as convincingly pointed out by Lützen (in Lützen [2010], p. 22-23), the employment of the circle and straight lines (or ruler and compass) can solve problems in which the construction of two points between two extremes are required, as in the case of the trisection of a given segment. One can certainly iterate the application of ruler and compass, and obtain the division of an angle in four parts, for instance. On the other hand, in order to solve the problem of trisecting a given angle, it is sufficient to construct

¹⁰⁴Bos [2001], p. 380.

¹⁰⁵For instance, with reference to the fig. 3.1.3, p. 3.1.3, it will be sufficient to construct point B in order to solve the problem of inserting one mean proportional between EO and OA .

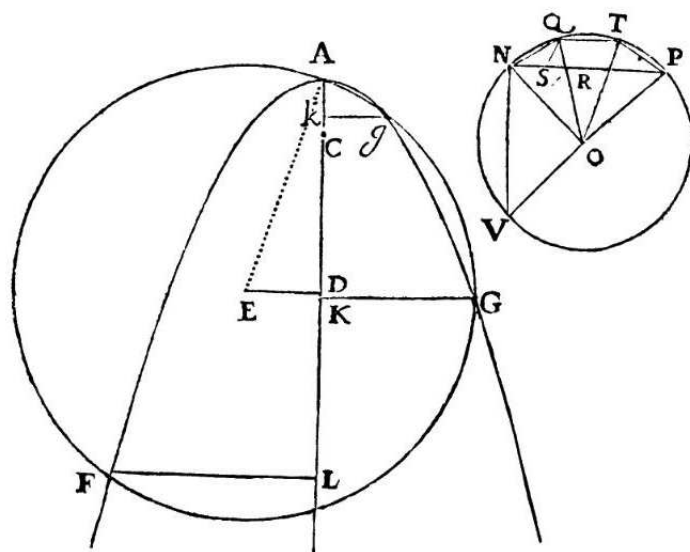

Figure 4.6.1: Descartes [1897-1913], vol. 6, p. 470.

only one point by means of a conic section, corresponding to one third of the given angle (with reference to the figure, it is sufficient to construct point Q , for instance), whereas the other point can be constructed by ruler and compass (it is sufficient to duplicate the angle previously obtained).

Conclusively, it seems that Descartes did not succeed in making sufficiently clear in which sense the notion of ‘curvature’ of the circle and of the conic sections, respectively, is related to the constructional capacities of these curves, and in which sense their constructional power makes the circle unsuitable in order to solve solid problems.

4.6.2 A case for unrigorous reasoning

If we consider the structure of Descartes’ reasoning when dealing with impossibility results, it will probably come as a matter of surprise for us that this argument is grounded, unlike modern impossibility proofs, on sole geometric considerations. Such an emphasis on geometric impossibility proof might be explained on several grounds.

Firstly, it should be pointed out that Descartes’ algebra of segments does not seem to possess the resources in order to recast salient differences in the ‘constructional power’ of

curves, to which I have referred above. Descartes acknowledged, among curves belonging to the same genre, curves having a more or less extended application in problem solving: he admitted, for instance, that the circle could solve less problems than the conic sections (see this chapter, p. 164). But such a difference in constructional power, which enters crucially in the impossibility of solving solid problems by plane means, did not correspond to any salient algebraic property. Indeed the principal characteristic of equations, namely their degree, does not allow one to distinguish between the circle and the conic sections, which are both associated to quadratic equations.

Secondly, I surmise that Descartes could have inquired about whether cubic equations were solvable by means of quadratic equations. He probably lacked the means to offer an answer, yet he should have realized that had he found a negative answer, this answer would correspond to an impossibility theorem cast into an algebraic form. But it was probably not easy to generalize this algebraic-proof structure to other relevant cases. For instance, how could one prove, by reasoning on algebraic equations alone, that the division of the angle into five equal parts cannot be solved by conic sections? The answer was arguably not obvious to Descartes (as it is not obvious for us, either): we might therefore envisage also an intention of generality on Descartes' side, behind his choice of grounding an argument of impossibility on a purely geometric argument.

A third reason concerns the role that algebra played with respect to geometric problems in the early modern mathematical practice. Algebra was generally conceived, during that period, as a method of discovery rather than a method of proof. As the case of Descartes' geometry illustrates too, the algebra of segments constituted, in the views of his author, a powerful method for searching the construction of problems, but it was hardly ever applied as a method for theorem proving. It seems that geometric arguments were invoked when it came to prove a theorem, either in geometry (it goes without saying) but also in algebra: the latter case is testified by Al Kwarizmi's proof for solving quadratic equations, or for Cardanos' proof of the algorithm for solving cubic equations.¹⁰⁶

Impossibility claims, as they are formulated in *La Géométrie*, are closer to theorems than to problems, since they are assertions whose truth is to be proved or disproved, rather than problems which express tasks to be accomplished. Therefore it must have been natural, for Descartes, to prove such impossibility results by means of a synthetic, geometric proof.

¹⁰⁶Both cases are evoked in Lützen [2010], p. 9-10.

In conclusion, Descartes deployed a loosely deductive, and in some points obscure argument in order to claim that solid problems could not be solved by plane means. However, even if this argument could not be recast either into an algebraic form or into a gapless deductive structure, it did not go forgotten, but it was the source for further considerations on impossibility, during the following years. In this sense, Descartes' impossibility argument can be considered an instance of 'unrigorous reasoning', according to the sense specified by P. Kitcher, with respect to those kinds of argument that: "appear to be candidates for adoption within the system of accepted proofs (...) however, there is no known way of recasting them as arguments which accord with the background constraints on proofs".¹⁰⁷

Just like other examples of unrigorous reasonings in a practice,¹⁰⁸ later mathematicians did not discard Descartes' argument on the impossibility of solving a third degree problem by ruler and compass, but tried to recast them into forms which agree with the background constraints on acceptable proofs.

Thus, as the historical analysis in Lützen [2010] shows, Descartes' aforementioned impossibility claims represent the starting point for a discussion on the impossibility of solving the classical problems (duplication of the cube and trisection of the angle) put forward by E. Montucla, in his *Histoire des recherches sur la quadrature du cercle* (1754).

Montucla valued the importance of impossibility arguments for pragmatical reasons, rehearsing motives that we have already seen in force in Descartes' *Géométrie*: by proving that a problem like the trisection was unsolvable by ruler and compass, Montucla argues, one could undermine the aims of "trisectors", by preventing geometers from searching vainly for the solution of solid problems without having examined their nature in advance.¹⁰⁹

Briefly speaking, Montucla envisaged a role for impossibility results similar to that suggested by Descartes in his *Géométrie*: these results should indicate the correct way of finding the solution to problems, by inhibiting impossible attempts. Moreover, the legacy

¹⁰⁷Kitcher [1984], p. 182.

¹⁰⁸Kitcher evokes, as paradigmatic examples of unrigorous argument are those reasonings using infinitesimals, since: "The problem is not simply that we cannot recast the argument as a deduction from accepted premises. As the mathematicians of the seventeenth and eighteenth centuries found, it is hard to present it in any way which does not introduce premises which are obviously false" (Kitcher [1984], p. 182).

¹⁰⁹See Montucla [1754], p. 235.

of cartesian geometry is explicit in Montucla's account of the classical problems, as we can read in his *Histoire*:

Ce n'est qu'à la Geometrie moderne qu'est due leur solution complète. Ce sont en effet seulement les Lumières qu'elle nous fournit, qui nous mettent en état de faire voir qu'ils sont d'une nature à ne pouvoir être généralement résolus par la Géométrie élémentaire, ce qui était un point nécessaire à démontrer avant de cesser ses efforts pour y parvenir par cette voye. Mais l'analyse moderne lève toute doute à cet égard.¹¹⁰

Presumably dissatisfied by Descartes' impossibility argument, Montucla advanced a proof of his own in order to claim that solid problems were not solvable by circles and straight lines. I will not enter into the details of this proof here, since it will bring me far from the historical setting I am investigating, but I shall remark that Montucla recast Descartes' geometrical argument into a more algebraic one. It should be pointed out that this algebraization of the cartesian argument does not yield an impossibility proof analogous to the modern, existing ones, since Montucla still relies on the the fundamental guideline of the theory of the construction of equations, that we have previously discussed in connection with Descartes' solution of solid problems: the gist of his argument lies in the (unproven) claim that a circle and a straight line necessarily cut in two points,¹¹¹ and therefore cannot be employed in order to exhibit the three roots of a cubic equation, to which both the trisection of the angle and the insertion of two mean proportionals can be eventually reduced.

Montucla was not the only one who attempted to reformulate Descartes' impossibility claim in a more algebraic vest. I shall point out, as another remarkable, although concise example, the following considerations expressed by James Gregory in a work from 1668, *Geometriae pars universalis*:

Hic conabor ostendere nullam vel aequationem cubicam posse resolvi ope solius regulae et circini: omnes aequatio cubica habet vel unam solam vel

¹¹⁰Montucla [1754], p. 273.

¹¹¹In Euclid's *Elements* it is proved that two circles meet *at most* in two points (Euclid III, 10), and it can be inferred, from proposition III, 2, for instance, that a straight line and a circle meet at most in two points (Heath [1956 (first edition 1908)], p. 10). Moreover, it is proved that a straight line touches a circle in one point (this condition expresses the fact that a line is tangent to the circle), but I cannot find any proof of the claim that a straight line cuts the circle in two points, or, equivalently, that if a straight line cuts (but does not touch) the circle in one point, it cuts it into another, distinct point.

tres radices reales, quae si invenirentur ope solius regulae et circini, seu intersectione circuli et lineae rectae, linea recta circulum secaret vel in uno solo puncto vel in tribus, quod utrumque est absurdissimum¹¹²

Gregory sketched, in the above passage, an argument in order to prove that no cubic equation could be solved by ruler and compass. Differently than Descartes, he did not make any direct reference to the trisection problem or to the problem of inserting two mean proportionals, but he referred instead to the problem of constructing solid equations (in the same way Montucla would do, after him). Gregory's starting point is the following true fact: every cubic equation has either one or three real roots. In order to construct these roots by a geometric procedure, we should construct either one or three intersection points between two curves. If these curves were the circle and the straight line, then the real roots could be found either by finding one or three intersection points between these curves. But, Gregory concludes, this is "very absurd" (*absurdissimum*) in both cases.

As no explanation is added to this sketch of a *reductio* argument, we can try to reconstruct the missing steps of Gregory's reasoning. As remarked above, it was known from Euclid's *Elements* that a circle and a straight line cannot intersect in more than two points. On the other hand, Gregory assumed that they cannot intersect (*secaret*) either in one point only. He was probably distinguishing, alongside with a classical tradition in geometry, two ways in which a straight line can meet a circle. A meeting between these curves could happen either when the straight line cut the circle (in this case, the straight line would be a secant to the circle) or when the straight line touched it (in this case, the straight line would be a tangent to the circle). Hence, Gregory had probably assumed that if a straight line cuts (but does not touch) the circle in one point, it should cut it in a second point too (see also above, note 111).

This topic is not dealt with any further in the *Geometriae Pars Universalis*, but it was certainly remarked as noteworthy by Gregory's contemporaries. For instance, Gregory's argument on the impossibility of solving cubics is reported almost literally in the review of *Geometriae Pars Universalis*, appeared in the *Philosophical Transactions*, in 1668.¹¹³

¹¹²*Geometriae Pars Universalis*, preface, unnumbered sheet: "I shall try to show here that no cubic equation can be solved by means of the circle and the straight line. Any cubic equation has either three or one real root, so that if it could be found by means of the sole ruler and compass, or by the intersection of a circle and a straight line, the straight line would cut (*secaret*) the circle either in only one, or in three points, but this is very absurd".

¹¹³See account of some Books [1668], p. 686.

Moreover, a perusal of Huygens' marginal notes reveals that the former geometer had meditated upon this very passage of Gregory's Book, writing in margin the following comment:

an non aequè impossibile est circulum secare sectionem conicam in uno vel tribus punctis. Et tamen hujusmodi intersectione aequationes cubicae solvuntur.¹¹⁴

It can be read as a consideration in favour of Gregory's reasoning, since it pointed to the use of a conic section (Descartes employed a parabola) as a legitimate and correct method in order to construct cubic equations.

4.6.3 Impossibility results as metastatements

I shall conclude my survey of Descartes' impossibility results by considering their function in the economy of the geometry. Descartes' assertions on the impossibility of solving problems by prescribed means assume a peculiar form. Firstly, let us remark that their content does not concern properties or configurations of geometric objects, but rather the general conditions under which a problem can be solved.

This point marks an important difference with respect to modern impossibility results. From the second half of XIX century, in fact, impossibility results assume the form of existential theorems, whose proofs requires to show the non-existence of a particular type of solution by an indirect argument: as an example, the modern proof that angles cannot be trisected by ruler and compass constructions starts from the assumption that the resulting third degree equation has roots in a quadratic extensions of the rationals, and from this assumption a contradiction is derived.¹¹⁵

In the context of *La Géométrie*, instead, Descartes employs the same word, '*faute*' (clearly reminiscent of Pappus' norm), in order to denote two different errors from the mathematical viewpoint. They are, on one hand, that of consisting in solving a problem by inadequate means, namely by using too complex curves with respect to the nature of a problem; on the other, the error consisting in trying to solve a problem by too (dimensionally) simple curves, which is an unattainable task. This latter error should be qualified as a practical rather than a mathematical one, in so far trying to construct a problem by

¹¹⁴In Hess [1980], p. 36: "But it is not impossible that a circle cuts a conic section in one or three points. And then, cubic equations are solved by such intersections"

¹¹⁵See ch. 1, sec. 1.3.2.

inadequate means is a 'useless' activity, which may waste energies and efforts but it is in no way an activity that we may qualify as mathematics.¹¹⁶ In Descartes' narration, both errors are methodological faults, because they stem from a common source: indeed they are imputable to the use of 'improper procedures' in problem solving, which ultimately depended on the 'ignorance', shown by the geometer, about the nature of a problem. It seems correct to claim that ignorance can be avoided, according to Descartes, when Pappus' original requirement, reinterpreted in algebraic terms, is respected.

This view of impossibility results complies with the structure of early modern mathematics, which can be considered as a constructive enterprise,¹¹⁷ in which non-existence proofs like the one demanded by modern impossibility results do not seem to fit properly. Assuming this thesis, we may conclude, following J. Lützen's analysis, that an impossibility result cannot stand as: "... a mathematical result (...) but a metareult saying that there is no reason to continue to look for a solution because there is none".¹¹⁸

However, in contrast with ancient meta-statements, as the impossibility claims arguably in force in the mathematics of late antiquity, Descartes justified the impossibility of solving the insertion of two mean proportionals and the trisection of the angle by ruler and compass by a mathematical argument.

4.6.4 The legacy of the cartesian programme: simplicity at stake

It should be noted that Descartes' reading of Pappus' norm in terms of dimensional simplicity left contemporary and later critics dissatisfied. Indeed the interpretation of Pappus' norm in terms of a simplicity requirement, to be set entirely upon algebra, was pointed out as a weakness of Descartes' programme.

Newton, for instance, took an opposite stance with respect to Descartes, considering the construction of solid problems by curves of higher degree than the parabola and the circle (namely conchoids) as a legitimate procedure, on the basis of a criterion of simplicity founded on easiness of geometrical construction, on an ideal similar to the 'easiness', excluded by Descartes as a criterion leading to errors.¹¹⁹ Simplicity remained

¹¹⁶Descartes disqualifies such attempts as "useless": "...se travailler inutilement a vouloir construire quelque problemes par un genre de lignes plus simple que sa Nature ne permet", Descartes [1897-1913], vol. 6, p. 444.

¹¹⁷Lützen [2009], p. 388.

¹¹⁸Lützen [2009], p. 388; see also Lützen [2009], p. 6.

¹¹⁹Bos [1984], p. 359ff.

a virtue in geometry, Newton observed, but algebra could not be the right measure for it. Geometrical simplicity, namely the simplicity of describing a curve, should be the criterion to be used in geometric problem solving.

A suggestive example in order to grasp Newton's adherence to significantly difference principles in problem-solving is the following passage, taken from the *Arithmetica Universalis* (1707), in which Newton invokes the importance of including in geometry mechanical curves like the cycloids, in virtue of the easiness of their description:

Si trochoides in geometriam reciperetur, liceret eius beneficio angulum in data ratione secare. Numquid ergo reprehenderes siquis haec linea ad dividendum angulum in ratione numeri ad numerum uteretur, & contenderes haec lineam per aequationem non definiri, lineas vero quae per aequationes definiuntur, adhibendas esse? Igitur si angulus e.g. in 10001 partes dividendum esset, teneremur curvam lineam aequatione plusquam centum dimensionum definitam in medium afferre, quam tamen nemo mortalium describere, nedum intelligere valeret; et haec anteponeere trochoidi quae linea notissima est, et per motum rotae vel circuli facile describitur.¹²⁰

In this passage, Newton deliberately subverted Descartes' line of thought, refusing the methodological distinction between geometrical and mechanical curves (to be examined in more detail in next chapter), on one hand, and the precept of simplicity, on the other. Similar positions can be encountered elsewhere among XVIIIth century mathematicians, to the point that, on the long run, constructions through mathematical instruments, which could secure the easiness of construction, were considered superior to: "... that usual one so long in vogue, of first obtaining an algebraic equation by means of the given conditions of the problem; and then finding the linear roots of that equation, which in almost all cases is troublesome, unelegant and unnatural, and in many other cases is intolerable, and almost impossible".¹²¹

¹²⁰Newton [1745], p. 238: "If the trochoid were received into geometry, it would be possible by its aid to divide the angle in a given ratio. Then, would you maybe criticize someone if he used this line in order to divide an angle in the ratio of a number to another number, and argue that this line is not defined through an equation, and that only such lines which are defined by an equation should be used? Indeed, if an angle were to be divided in 1001 parts, we would have to employ a curve line defined by an equation of more than one hundred dimensions, which however no mortal would dare describe, and not even understand, and we would have to prefer this line to the trochoid, which is a well known line, and which is described easily by the motion of a wheel or a circle".

¹²¹Stone [1723], p. 324. See also Bos [1984], p. 367.

The use of algebra as a guide for the art of discovery in geometry could be seen as compromising the major virtues of classical geometry. Indeed, Newton stressed once more, at the beginning of the '80s, when algebra is regarded as a criterion and a guideline in geometric problem-solving:

progress has been brought and far-reaching, if your eye is on the profuseness of the output but the advance is less of a blessing if you look at the complexity of its conclusion. For these computations, progressing by means of arithmetical operations alone, very often express in an intolerably roundabout way quantities which in geometry are designated by the drawing of single lines.¹²²

In a similar vein, Jakob Bernoulli's critique contained in his *Notae et animadversiones tumultuariæ in universum opus* (published in 1695 as an appendix to the fourth latin edition of geometry) are instructive to this effect. I will merely quote the core of Bernoulli's criticism, leaving aside the example he produced to illustrate it:

Si sola Dni. Descartes auctoritate standum sit, e pluribus curvis, per quas aliquod Problema construi potest, semper illa eligenda venit, quae generis est simplicissimi, ut maxime constructionem et demonstrationem Problematibus multo impeditiorem reddat, quam alia, quae uno alterove gradu magis composita est. At si asserti rationes desideremus, altum silentium . . . Nam, quamquam curva gradus altioris quiddam forte habeat in natura sua magis compositi, quam alia inferioris, ratiocinium tamen quo id colligimus, in constructione problematis non attenditur, sed tamquam jam antea factum supponitur; et nunc solummodo spectatur curvae descriptio.¹²³

Bernoulli agrees that the dimensional simplicity reflects a property of the nature of curves ("quamquam curva gradus altioris quiddam forte habeat in natura sua magis compositi": I remark that Bernoulli does not mention Descartes' ordering by couples of degrees, but by single degrees), but disagrees upon the choice of the dimensionally simplest curve

¹²²In Guicciardini [2009], p. 77.

¹²³In my translation: "If we had to stay to the sole authority of M. Descartes, among the several curves by which a problem can be constructed, it must be always chosen the one of the simplest kind, so that it makes the construction and demonstration of the Problem much more convoluted, than the other, which is more complex for this or that degree. But if we wish the motivations for such an assertion, then a deep silence . . . Indeed, although the curve of higher degree has maybe something more composite in its nature, than the one of lower degree, the reasoning through which we seize this, is not respected in the construction of the problem, but it is presupposed as already done, and then only the description of the curve is regarded."(in Descartes [1695], p. 444-45).

in problem solving, since when it comes to the construction of a problem, only the description of a curve (a criterion related to 'easiness') should matter.¹²⁴

On the other side, Descartes' requirement of solving a problem by the curve of the simplest kind became an important factor in the shaping of mathematical practice throughout XVIIIth century, in particular with respect to a subject closely connected to geometric problem solving, namely the construction of equations.

Dimensional simplicity was indeed emphasized as an important properties that solutions of problems ought to possess. Many outstanding mathematicians became engaged in this research program almost until the beginning of XVIIIth century. Let us recall that constructing an equation meant to find two curves whose intersection points (or more precisely, the abscissa of the intersection points) offered the geometrical solutions to the equation itself. Since the problem generally admits infinite solutions, it gradually became customary to select, among the possible solutions, the curves of lowest degree, on the ground of Descartes' requirement.¹²⁵

On a related note, Descartes' discussion of simplicity can be considered a common source for the methodological reflections of two authors who shall be examined in the sequel: James Gregory and G. W. Leibniz.

Descartes' criteria for simplicity are evoked, for instance, in a noteworthy unpublished tract written by Leibniz in 1674: *De Constructione*.¹²⁶ This tract is a methodological survey, in which Leibniz considered the role of simplicity in the choice of solving methods,

¹²⁴J. Bernoulli used the word 'ἀγεομετρησία' in order to refer to the flaw of using illegitimate means in the solution of a problem : "nihil prorsum video, quid CARTESIUM hoc in passu ab ἀγεομετρησία vitio, quod ipsemet perstringit saepius, liberare queat ...". In Henk Bos' translation : "I can see nothing that could in this case acquit Descartes from the vice of acting ungeometrically, which he mentions so often" (in Bos [1984], p. 365).

¹²⁵The construction of degree up to four became a standard topic on expository writings on algebra and geometry from the second half of XVIIIth century, among which we may name: F. de Sluse's *Mesolabum, seu duae mediae proportionales inter extremas datas per circulum et ellipsim vel hyperbolam infinitis modis exhibitae* (1659), de la Hire's *Nouveaux elemens des sections coniques, les lieux geometriques, la construction ou effection des équations* Paris 1679, Wallis' *Algebra* (1685, 1693), Sturm's *Mathesis enucleata* (1689, Engl. tr. 1700), Ozanam's *Dictionnaire Mathématique* (1691), and *Nouveaux elements d'Algèbre* (1702), Harris' *Algebra* (1702) and *Lexicon* (1704), Guisnée's *Application de l'algèbre à la géométrie* (1705), L'Hôpital's *Traité analytique des sections coniques et de leur usage pour la résolution des équations dans les problèmes tant déterminez qu'indéterminez* (1707), Newton's *Arithmetica universalis* (1707) and Reyneau's *Analyse démontrée* (1700). See Bos [1984], p. 354ff.

¹²⁶Now published in AV11, 45.

within a more comprehensive discussion on the virtues of the synthetic geometry of the ancients and the analysis of the moderns.

With respect to our theme, it should be pointed out that Leibniz expressed the necessity of adopting general rules (*regulas constructionum elegantium*) in problem solving, in order to avoid to employ useless curves, or avoid not to employ those curves that fall within our power,¹²⁷ and thus perform 'elegant' constructions.

Indeed, according to Leibniz, a geometric construction should not be merely understood as the exhibition of a geometric objects or of a configuration of objects, starting from given ones. This process should also occur in the most 'elegant' way:

Ergo constructio eo censi debet elegantior, quo lineae quas ducere necesse est simpliciores paucioresque sunt. Simpliciores censentur geometricae mechanicis, et inter geometricas eae quae gradus sunt inferioris, superioribus. Si duae sint ejusdem problematis constructiones, quarum altera paucioribus, altera simplicioribus lineis utatur, posterior praeferenda plerumque est.¹²⁸

It can be inferred, from the above passage, that Leibniz's notion of elegance in geometrizing was clearly influenced by the cartesian concept of dimensional simplicity: simplest lines, namely lines of the lowest possible class should be always preferred to solutions recurring to fewer lines.¹²⁹

¹²⁷"ne scilicet inutilibus utamur, aut ne quibusdam utilibus in nostra potestate siti non utamur.", AVII, 45, p. 417.

¹²⁸"Thus, a construction must be considered the more elegant the simpler and fewer are the lines it is necessary to draw. Geometrical lines are thought to be simpler than mechanical, and among the geometrical ones, those which are of lower degree are thought to be simpler than those of higher degree. If there are two constructions of the same problem, one of which employs fewer lines, and the other simpler lines, the latter is to be preferred in general" (in AVII, 45, p. 418).

¹²⁹Cf. *De constructione*, AVII, 45, p. 418: "Hinc patet, non esse utendum linea superiore ad problema inferius, nisi ea linea superior jam tum adsit sive quod data sit in problemate, sive quod alia ex causa describenda fuerit" ("From these things it appears that one should avoid using a higher line for a lower problem, unless this higher line is already available, either because it is given in the problem, or it had to be described for other reasons"). It should be pointed out that Leibniz had to restrict the validity of Descartes' simplicity precept, as a consequence of a problematic asymmetry concerning the correspondence between algebra and geometry, although he recognized the global validity of the norm. The exception indicated here concerns a problem already explored by Schooten and Huygens (cf. for instance Descartes [1659-1661], vol. 1, p. 322ff.), for instance, like the construction of a normal to a given parabola, from a point located outside the curve. The problem can be analyzed and reduced to a cubic equation, which can be constructed, through Descartes' protocol, by a circle and a parabola. But in the problem at hand, the parabola is given, so that, strictly speaking, it is sufficient to construct a circle in order to solve the problem. This caused a serious fracture between geometric and algebraic criteria in judging the proper level of a problem: geometrically, the problem was plane, since it required

the sole construction of a circle, which could intersect the given parabola in the correct points so as to produce the unknowns. Algebraically, the problem yielded an equation of third degree, and was therefore solid, according to the classification of *La Géométrie* (Bos [1984], p. 356-357).

Chapter 5

Mechanical curves in Descartes' geometry

5.1 Mechanical curves in Descartes' geometry

In the second Book of *La Géométrie*, Descartes excludes from geometry and ranges into mechanics the spiral, the quadratrix and other similar but unspecified curves, and motivates his judgement on two grounds. On one hand they are generated by a couple of separate motions, and on the other, these motions do not entertain an exact relation between them.¹

The distinction between geometrical and mechanical curves is a cornerstone in Descartes' program, since it shapes the boundaries of geometry and dictates the legitimate procedures in the synthetic part of problem solving. However, despite the centrality of this issue and Descartes' self confidence about the non-geometrical nature of certain curves, the rationale of his distinction still defies the interpretation of modern scholars.

As I have anticipated above, we can evince from Descartes' considerations that the criteria for excluding a curve from geometry rely on the way in which the curve is generated.

Descartes was acquainted with the genesis of the quadratrix and the spiral from the available traditional sources dealing with linear problems and curves, which included

¹"... la Spirale, la Quadratrice, & semblables (...) n'appartiennent veritablement qu'aux mechaniques, & ne sont point du nombre de celles que ie pense devoir icy estre receues, a cause qu'on les imagine descrites par deux mouvements separés & qu' en ont entre eux aucun rapport qu'on puisse mesurer exactement".Descartes [1897-1913], vol. 6, p. 390.

Pappus' *Collection*, Archimedes' treatise *On Spirals* and indirectly Proclus' *Commentary* on the first book of Euclid's *Elements*.²

Unlike the case of the circle and other curves constructible by geometric linkages, in the construction of the quadratrix or the spiral reported, for instance, by Pappus, two movements are set independently one from another except from certain kynamical parameters, as the speed of the moving segments or points, which is assumed uniform for both of them.

Descartes arguably knew, via ancient and early modern sources, other curves that could be characterized through a similar description. One of them is the cylindrical helix: a curve, let us recall, mentioned in Proclus' *Commentary* and, before it, in Pappus' Book IV of the *Collection* (proposition 28), although its fully-fledged description is set out in book VIII, devoted to mechanics.³

A reader of Pappus *apud* Commandinus could also find, already in Book IV, a substantial anticipation of the description of the cylindrical helix, thanks to the following

²There is evidence that, by 1637, the spiral and the quadratrix were well-known curves to geometers. Several sources can be found dealing with the description of these curves (for a detailed survey, see Ulivi [1990], in particular, pp. 517- 541). Techniques for the construction of the spiral are discussed in J. Besson, *Theatrum instrumentorum et machinarum* (1578); S. Stevin, *Hypomnemata mathematica* (1605-1608), p. 23; (and in Stevin, *Oeuvres*, p. 351), D. Schwenter, *Geometriae practicae novae et auctae* (1625), p. 163; V. Leotaud, *Geometriae practica* (1630), pp. 436-39; S. Marolois, *Géométrie contenant la théorie et pratique d'icelle*, in *Oeuvres mathématiques* (1628), p. 10. The quadratrix started to capture the attention of mathematicians a bit later, after the publication of Pappus' *Collection* in latin, and mostly under the suggestion of Clavius, who dedicated a study to this curve in his second edition of the *Elements* [*Elementa* (1589), p. 894 - 918]. The quadratrix was studied, between 1598 and 1637, by F. Viète, *Variorum de rebus mathematicis responsorum, Liber VIII*, (1593) p. 11, again by Clavius, in his *Geometria Practica* (1604), p. 320-329, by P. Van Lansbergen, *Cyclometriae novae libri duo* (1616), in V. Léotaud, *Elementa . . .*, p. 441-442, T. Bruni, *Dell'Armonia astronomica et geometrica* (1631), p. 37-38, and by B. Sover, *Curvi ac recti proportio (. . .) libri sex*, (1630), p. 388-390. This list may not be exhaustive, but it is indicative, I surmise, of the interest for the spiral and the quadratrix in the 60 years preceding the publication of *La Géométrie*. Most of these works (which Descartes was, in part, acquainted with) involved attempts to offer alternative constructions of the curves under exam, and were deployed in the backdrop of the classical accounts of Pappus (for the spiral and especially the quadratrix) and Archimedes (for the spiral). Extant documents reveal that Descartes was acquainted with the quadratrix since 1619: the curve is in fact mentioned in his letter to Beeckman that I have reproduced above, and it is considered as a geometrical curve. It is possible that Descartes learned about the quadratrix from Beeckman himself (who indeed studied the curve in 1614-15, as we can evince from his diary), but he did not explicitly discard this curve from the number of geometrical ones until 1629 - from the end of this year dates in fact a critique to the construction of this curve presented by Clavius in his commentary to the *Elements*. Concerning the spiral, we can assume that Descartes knew it through the accounts in Pappus' *Collection* and possibly Archimedes (on Descartes' early acquaintance with Archimedes' works, see Sasaki [2003], p. 118-121).

³A second important source for the helix is Proclus' *Commentary* (Proclus [1992], p. 86).

commentary added by the editor:

Describetur autem linea spiralis in dicti cylindri superficie, si intelligatur in linea CM punctum aliquod incipiens a C aequaliter ferri usque ad M , et eodem tempore lineam CM rectam ad planum circuli permeare circumferentiam CDA punctum etenim illud lineam spiralem describet, cujus principale accidens est, ut sumpto quovis puncto in ipsa, quod exempli gratia sit H ductaque HD ad planum perpendiculari, habeat HD ad circumferentiam DC eam proportionem, quam tota CM habeat ad circumferentiam CDA .⁴

The helix is called by Commandinus a "spiral line on the surface of a cylinder", and shares similar properties with the spiral in the plane and with the quadratrix, even if it is a three-dimensional curve. It results in fact from the combination of two motions, a uniform translation of a point along a segment which revolves, at the same time, uniformly around a circumference.

Several studies⁵ allow us to claim that Descartes was acquainted with this curve before 1637. A curve named 'helix' (*ligne hélice*) is in fact summoned by Descartes, in the course of an exchange with Mersenne from autumn 1629, in the context of a discussion about a 'mysterious' problem of dividing circles in 27 and 29 parts. The only mention of this problem is contained in a letter written by Descartes on October 8, 1629:

De diviser les cercles en 27 et 29, ie le croy, mechaniquement, mais non pas en Geometrie. Il est vray qu'il se peut en 27 par le moyen d'un cylindre, encore que peu de gens en puissant trouver le moyen; mais non pas en 29, ny en tous autres, & si on m'en veut envoyer la pratique, l'ose vous promettre de faire voir qu'elle ne'est pas exacte.⁶

According to the interpretation advanced in Bos [2001], this problem can be plausibly identified with that of dividing an angle into an arbitrary number of parts.⁷

⁴Commandinus [1588], fol. 58v: "A spiral line will be described on the surface of the said cylinder, if one conceives that a point is moved uniformly (*aequaliter*) along line CM from C to M , and at the same time the straight line CM , orthogonal to the plane of the circle, revolves around the circumference CDA . In fact the point [C] will describe the spiral line, whose symptom (*principale accidens*) is such that, taken any point in it, for example H , and traced HD perpendicular to the plane, HD has to the arc DC the same proportion that the whole line CM has to the circumference CDA ". This description is summarized also few pages later (fol. 60r).

⁵See in particular: Mancosu [1999], Mancosu [2007] and Mancosu and Arana [2010].

⁶Descartes [1897-1913], vol 1, p. 25-26.

⁷Even so, some reservations can be advanced towards this interpretation. The reference to two circles in the text of the problem (in Descartes' account) is obscure, since one arc (and eventually one circle) is

Descartes returned on the subject one month later, commenting upon an alleged solution due to an unknown Mr. Gaudey, which seems to have made appeal to the curve designated by the name 'helice':

L'invention de Mr Gaudey est tres bonne & tres exacte en pratique; toutesfois affin que vous ne pensiés pas que ie me fusse mespris de vous mander que cela ne pouvoit estre Geometrique, ie vous diray que ce n'est pas le cylindre qui est cause de l'effait, comme vous m'aviés fait entendre, et qu'il n'y fait pas plus que le cercle ou la ligne droite, mais que le tout depend de la ligne helice que vous ne m'aviés point nommee & qui n'est pas une ligne plus receue en Geometrie que celle qu'on appelle quadraticem, pource qu'elle sert a quarrer le cercle & mesme a diviser l'angle en toutes sortes de parties esgales aussy bien que celle cy & a beaucoup d'autres usages que vous pourrés voir dans les elemans d'Euclide commentés par Clavius.⁸

As we can read in the text above, the 'ligne helice' is explicitly treated on a par with the quadratrix of the ancients: one of the reasons on which Descartes grounds their similarity lies on the fact that they are generated out of two independent motions, as he remarks in the sequel of the same letter from 13th November 1629.⁹ Such a description recalls the characterization of mechanical curves in *La Géométrie*. Even without advancing any definitive argument, Mancosu [2007], and especially Mancosu and Arana [2010], argue convincingly that the curve named "hélice" by Descartes, in the aforementioned letter, may be the cylindrical helix whose description can be also found in Pappus' *Collection*.¹⁰

usually invoked in the statement of the problem (see for instance proposition 35 of the Book IV of the *Mathematical Collection*, in Sefrin-Weis [2010], p. 155). Moreover, Descartes claims specifically that only the division in 27 parts can be done by a cylinder (also evoked in the subsequent letter from November 13, 1629), so he might be convinced that the problem of dividing the circles in 27 and 29 parts could be solved by different methodologies. To these puzzles we may add the following one: the division of an angle into 27 parts is a simple case of a reiterated trisection, whereas the division in 29 parts cannot be simplified (being 29 a prime number). Descartes was probably aware of this fact. But if it is the case, we should conclude that Descartes believed that the problem of dividing the circle in 27 parts was not doable in geometry: a conviction in striking opposition with the construal of geometricity presented in *La Géométrie*. Indeed, since the division of a circle in 27 parts is reducible to a solid problem, recognized as fully geometrical, it must be a geometrical problem too.

⁸Descartes [1897-1913], vol 1, p. 70-71.

⁹In the letter to Mersenne from November 13, 1629, Descartes noted several similarities between the helix and the quadratrix, among them the fact that both curves are generated by "deus mouvemans qui ne dependent point l'un de l'autre" (Descartes [1897-1913], vol. 1, p. 70-71). The other analogies highlighted by Descartes (concerning their pointwise construction and their use for the quadrature of the circle) will be examined later.

¹⁰Besides, it should be pointed out that in the mathematical literature of XVIIth century, "la ligne helice" could refer either to the Archimedean plane spiral, or to the cylindrical helix; therefore Descartes'

Conclusively, this interpretation of the 1629 letter, together with the *addenda* of Commandinus version of the *Collection*, add plausibility to the hypothesis that Descartes was acquainted by 1637 with the cylindrical helix, and to the thesis that he considered this curve as mechanical, on a par with the quadratrix and the spiral.

In the commentary to the first (1649) and second (1659) latin edition of Descartes' geometry, Frans Van Schooten enriched the number of mechanical curves discussed in the french 1637 edition by studying the generation and the main properties of the cycloids, those curves traced by any point on the plane of a circle (or, more generally, of a convex figure), which rolls without gliding on a straight line.¹¹ The best known and studied example in XVIIth century was represented by the 'ordinary cycloid' generated by any point on the circumference of the rolling circle, as Van Schooten explains (fig. 5.1):

Ut si super recta linea AE circumvolvatur circulus, rota sive circulus $ABCD$, donec punctum ejus A , in quo dictam lineam tangit, eidem rursus occurrat in E : describet punctum A hoc motu lineam curvam AFE , quae Trochoides sive Cycloides appellatur. Idem intellige de quovis alio puncto, extra vel intra rotam sive circulum assumpto, excepto tantum ejus centro.¹²

mention is ambiguous as such (Mancosu and Arana [2010], p. 408). Bos had preferred the identification of "la ligne helice" with an archimedean spiral (see Bos [2001], p. 345), whereas Mancosu and Arana suggest that nothing goes against interpreting Descartes' helice as a cylindrical helix, since he presumably possessed sufficient knowledge of this curve by the time, and this curve can successfully solve the problem of dividing the angle into equal parts. I point out that one of the sources through which Descartes might have come to know the cylindrical helix was Pappus' Book IV of the *Collection* in the version of Commandinus.

¹¹Descartes [1659-1661], p. 268-269. For the history and the main properties of this curve, one can consult the modern studies contained in (Teixeira [1995], vol. II, pp. 133-150) or (Loria [1930], vol. 2, chapter VIII). The cycloid was studied in depth in the early modern period, although already in XVIIth century its origins were debated (see also Teixeira [1995], pp. 133-134). Incidentally, the history of the curve was investigated systematically for the first time in an informed account given by Wallis, in a letter published in 1695, in the *Philosophical Transactions of the Royal Society* (see Wallis [1695]). Wallis traced the first mentions of this curve back to Mersenne - who supposedly identified it in 1615- and Galileo, who knew this curve since 1590. But Wallis went even farther, boldly stating that neither Mersenne, nor Galileo were the first who discovered this curve. Even before Bovillus, Wallis added, it results that this curve was known to Cusanus. In order to lend credence to this hypothesis, Wallis mentioned a mechanical solution of the rectification of the circumference, presumably due to Cusanus. This solution is simply obtained by the rolling of a circle (interestingly, Wallis copied the original drawings in the manuscripts that he perused); from this, Wallis deduced that Cusanus must know how to describe a cycloid. Despite this bold, and ultimately poorly grounded conjecture, Wallis showed more caution in the end of his letter, remarking that, even if there are elements to date the cycloid back to XVIth century, only during his own century this curve had been studied in depth. Indeed the study of the cycloid of the circle in XVIIth century, pioneered by Roberval, revealed interesting properties, whose study prompted the fruitful development of new methods for the computation of area, tangents and volumes, which were later extended to other curves.

¹²Descartes [1659-1661], p. 265: "And if a circle or a wheel $ABCD$ is revolved over line AE , until

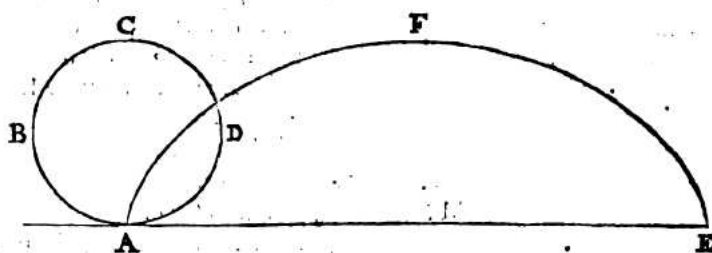

Figure 5.1.1: Descartes [1659-1661], p. 265.

Descartes himself had unhesitatingly excluded cycloids from geometry, as he wrote to Mersenne, on 23rd August 1638:

... Les courbes descrites par des roulettes sont des lignes entierement mechaniques & du nombre de celles que j'ay rejeттées de ma Geometrie ... ¹³

Following Descartes' opinion, Van Schooten ranged cycloid among those lines "quas pro geometricis pari jure habere non licet".¹⁴ The reason is further detailed in these terms:

De supra dicta linea AFE notandum, eam duobus motibus describi, inter se distinctis; recto nempe, quo circulus $ABCD$ defertur ab A ad E , et circulari, quo puncto in ejus circumferentia A (quod Trochoidem describit) rotatur circa centrum, dum movetur per lineam rectam ipsi AE aequalem & parallelam.¹⁵

The same criterion adopted for ruling the spiral and the quadratrix out of geometry is extended in order to exclude cycloids too: these curves are in fact generated by two distinct motions ("*duobus motibus describi, inter se distinctis*").

one of its points A , which touches the said line, returns again to itself in point E ; such a point A will describe, out of this motions, the curve line AFE , which is called Trochoid or Cycloid. Understand the same of any other point, taken outside or inside, or on the wheel or circle, except only for its center".

¹³Descartes [1897-1913], vol. 2, p. 312-313. I remark that Descartes was well familiar with the cycloid of the circle, of which he computed the area in 1638, as we know from the correspondence with Mersenne (for a technical account of Descartes' achievement, see, for instance, Costabel [1985], p. 46-48).

¹⁴Descartes [1659-1661], p. 264: "which is not legitimate to consider to equal right geometrical".

¹⁵Descartes [1659-1661], p. 266: "Concerning the above mentioned line AFE it must be remarked that it is described by two motions, distinct one from the other ; indeed a rectilinear one, by which the circle $ABCD$ is deplaced from A to E , and a circular one, by which the point A on its circumference (which describes the trochoid), rotates around the center, while moving through a straight line equal and parallel to AE ".

5.2 On Geometrical and Mechanical constructions

From our vantage point, the cartesian distinction between geometrical and mechanical curves appears as a forerunner of the distinction between algebraic and transcendental curves. The idea of separating geometrical from mechanical curves on the ground of their expressability through algebraic equations is certainly grounded in Descartes' geometry (as we learn in *La Géométrie*, the possibility of expressing a curve via a finite polynomial equation is posited as an essential property of acceptable curves), and was also adopted by later commentators, as I will remark below, as the fundamental rationale in order to separate acceptable from non-acceptable curves in geometry.¹⁶

However, despite the opinion of some scholars,¹⁷ I surmise that it remains disputable whether Descartes adopted an algebraic criterion as the touchstone for distinguishing geometrical from mechanical curves.

As a start, whilst holding the possibility of associating a curve to an equation as a fundamental achievement of Descartes' *Géométrie*, it should be remarked that Descartes defined a curve as an exact, and therefore geometrical object on the ground of its 'specification by genesis'. Unlike the case of the circle and other curves which are constructible in a canonical way through a suitable geometric linkage, mechanical curves are not constructed, according to Descartes' account, by employing a unique device, but through a system formed by two segments, whose movements are set independently one from another except from certain kynematical parameters, as the speed of the moving axes, which are required to be uniform for both of them. It is true that also geometrical linkages are movable configurations but, in their cases, the kynematic components of the motions (for instance, the velocity) do not enter essentially in determining the shape - and therefore the nature - of the curve traced.¹⁸ The distinction between the genesis of a curve by a geometric linkage and the genesis of a curve in a mechanical way is mathematically clear: only the second kind of genesis involves the appeal to kynematic constraints as an essential component of the construction of such curves, like the quadratrix and the spiral, that are henceforth called "mechanical".

¹⁶Descartes [1897-1913], vol. 6, p. 392.

¹⁷See, for instance, Sasaki [2003], p. 71.

¹⁸This point might be at the origin of the somewhat puzzling remark made by Descartes, who avowed to one of his correspondents, Ciermans, that he had not dealt with motion in *La Géométrie* (the letter is from 23rd March 1638. See Descartes [1897-1913], vol. 2, 70-71).

Such a clearcut distinction is however hindered by two pitfalls, which do not make it a workable criterion in order to separate geometrical from mechanical curves. The first difficulty originates within the early modern history of curve constructions. As I shall argue with more details in the sequel, renaissance and XVIIth century geometers had developed procedures - some of them certainly known to Descartes too - in order to legitimate the construction of the spiral, the quadratrix and the helix, namely those 'mechanical curves' mentioned by Descartes in *La Géométrie*, avoiding a direct appeal to independent motions.¹⁹

I shall discuss two kinds of procedures, elaborated in XVIth and XVIIth century, in order to describe mechanical curves, such as the quadratrix and the spiral, without any direct appeal to twin independent motions. The first alternative procedure consists in contriving the twin motions into a unique mechanism, or a unique apparatus, involving the use of strings or threads, or the possibility of twisting concrete objects in order to adapt them to curvilinear surfaces. The second procedure consists in generating the desired curve by a pointwise construction.²⁰

As a consequence, the problem could be raised of understanding whether, in the light of those new construction procedures, mechanical curves could be judged recevable with respect to the standards in force within cartesian geometry. I shall argue that a reference to both methods can be found in *La Géométrie*. Descartes was presumably aware of this conceptual difficulty, and provided an answer in *La Géométrie* through a detailed distinction between acceptable and unacceptable methods for constructing curves.

The second pitfall can be introduced by the following remark: procedures for the mechanical generation of curves via independent motions can be employed for the description of geometrical curves as well. A simple case at point is that of the parabola: this curve can be described either via the composition of two independent motions, one horizontal and uniform, the other vertical and uniformly accelerated, as in Galileo, *Discorsi e dimostrazioni matematiche*, for instance,²¹ or through a suitable geometric linkage, as it is illustrated in Frans Van Schooten's treatise *De organica conicarum sectionum in plano*

¹⁹Consult, for instance: Bos [2001], in particular chapters 1, 9, 11, 12, 14; Mancosu [1999], chapter 3.

²⁰I do not exclude that other tracing procedures might exist, to the same effect. A promising, still unexplored domain of research (at least to my knowledge) concerns studies in solid geometry in renaissance and early modern period. In fact, as known from ancient examples, curves can be also generated by the intersection of solid figures. In particular, attempts are made, in Pappus' *Collection*, to generate the quadratrix in this way, by an appeal to 'loci in the surface' (see Pappus, *Collectio*, IV, 28-29).

²¹See Galilei [2005], vol II, p. 772-807.

descriptio.²² This example is sufficient to cast doubts on the appropriateness of a criterion based on properties inherent to the procedures for constructing curves, in order to classify curves themselves: nothing impedes, in principle, that a curve which has not been constructed by a geometric linkage is constructible in this way, and is therefore a geometrical curve, according to cartesian standards.²³

This being said, I will search for reasons that may rationally justify Descartes' self-confidence about the mechanical nature of the curves evoked above, namely the spiral, the quadratrix and the cylindrical helix.

5.2.1 Constructions by means of twisted lines or strings

Construction of the cylindrical helix (Guido Ubaldo)

Constructions of mechanical curves that made essential use of the possibility of twisting a segment or a polygon so as to adapt it to a curved surface or line mostly appeared in treatises of practical geometry, architecture or mechanics. In the following lines, I will confine myself to a couple of examples taken indeed from such contexts: on one hand, a construction of the cylindrical helix, included in the treatise written by Guido Ubaldo del Monte (1545-1607), a disciple of Commandinus: *Mechanicorum libri* (1577), and on the other, a construction of the archimedean spiral devised by the german geometer Daniel Schwenter (1585-1636) in his *Geometriae Practicae novae libri* (1625). The latter construction, in particular, presents similarities with a construction devised by Christiaan Huygens, and contained in a manuscript written in 1650.²⁴

The cylindrical helix has a crucial position in Book VIII of the *Mathematical Collection* - a book dedicated indeed to mechanics - because it represents the form assumed by the thread of a screw, one of the fundamental machines in ancient and renaissance mechanics.²⁵

²²See van Schooten [1656-57], p. 356-359.

²³The point has been raised and discussed in Mancosu [1999], Mancosu [2007] and Mancosu and Arana [2010].

²⁴Huygens [1888-1950], vol. 11, p. 216.

²⁵In Commandinus' translation of Pappus' *Collection*, in fact, this machine figured as one of the five simple machines, to which, according to Hero of Alexandria, all complex machines could be reduced (the other ones were (lever, wheel and axle, pulley, wedge). See Laird and Roux [2008], in particular the *Introduction*, p. 4.

Probably because of its essential role played in the realization of fundamental machines, the description of the helix often recurred in early modern treatises of mechanics. A noteworthy example can be found in the treatise *Mechanicorum Libri*. In this momentous work, Guido Ubaldo pioneered the attempts to give a systematic account of mechanical knowledge contained in ancient sources, specifically Pappus and Hero, while taking as a methodological model the deductive architecture of Euclid's and Archimedes' mathematical works.²⁶

In particular, Guido Ubaldo centered the last chapter of his treatise on screws ("*De cochlea*", in Del Monte [1577], p. 120). In the first proposition of this chapter,²⁷ Guido Ubaldo claimed that a wedge, appropriately coiled around an axle, constructs a screw. In order to prove this claim, he exposed a geometric procedure in order to construct a helix revolving around a cylinder of finite height.

Guido Ubaldo constructs a cylindrical helix about a given cylinder of finite height MN (fig.5.2.1, which reproduces the original in Del Monte [1577], p. 121) by wrapping around its surface a right-angled triangle EFG , whose greatest leg GF equals the base of the cylinder, whereas the other leg EF , equal to half of the height of the cylinder, is made to coincide with a generatrix MN of the cylinder itself. In this way, the hypotenuse GE , wrapped around the cylindrical surface, describes the path of an helix, which starts at the base ON of the cylinder and terminates at point P , middle point of MN . In order to construct the remaining part of the helix, Guido Ubaldo places on the cylinder another right-angled triangle, KIH equal to the former, but in such a way that its leg KI is wrapped around base LM of the cylinder, and the leg IH lies on MN . Therefore, the hypotenuse KH of the second triangle, twisted around the cylindrical surface, can extend the path of the helix NQP , until it reaches point M .

Let us observe that the procedure just resumed engenders a helix on the surface of a given finite cylinder without direct appeal to a pair of independent motions;²⁸ it has recourse, instead, to the 'twisting' of a segment (namely, the greatest leg in both triangles in fig.

²⁶Cf. *Becchi et al. [2013]*.

²⁷Del Monte [1577], p. 121.

²⁸An analogous construction can be found in Hero's *Mechanics*, which was not known to renaissance and XVIIth century geometers (see Mancosu and Arana [2010], p. 415). The same construction is given in Pappus' Book VIII (Pappus [1876-1878], III, p. pp. 1109–1111), a likely source of Guido Ubaldo's construction. A third construction of the helix, similar to Hero's and Pappus' one, in so far it is based on the bending of a segment into a around a cylinder, is given by Vitruvius, in the *De Architectura*, X, 6 (Mancosu and Arana [2010], p. 416).

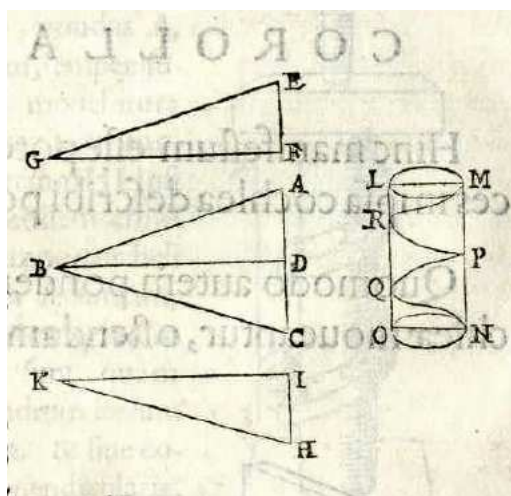

Figure 5.2.1: Del Monte [1577], p. 121.

5.2.1) so as to adapt it to a circumference (I observe that this construction requires that one can rectify the circumference, since sides GF and IK have the same length as the circumferences of diameters ON or LM).

However, it should be pointed out that, even if Guido Ubaldo's discourse is about geometrical figures- he refers, in fact, to "triangles" that are made to coincide with a "cylinder" - he considers, from the beginning of his proposition, that the triangles required for the construction of the helix are obtained from the splitting of a wedge, namely a concrete objects, possibly made of a supple material that can be twisted around a cylindrical shaft.²⁹ It seems, therefore, that the physical properties of the wedge enter essentially in the description of the helix reported in the *Mechanicorum Libri*.

5.2.2 Construction of the spiral (Schwenter, Huygens)

We find, among renaissance and early modern geometers, other techniques for describing mechanical curves based on similar devices to the ones described by Guido Ubaldo. A noteworthy example is represented by the tracing of the archimedean spiral. Following a suggestion made by H. Bos³⁰ one can find an example of such instrument in one of Huygens' notebooks, more precisely in a manuscript of 1650.³¹

²⁹Del Monte [1577], p. 121

³⁰Bos [2001] p. 347-348; Panza [2011], p. 81-82.

³¹Huygens [1888-1950], vol. 11, p. 216.

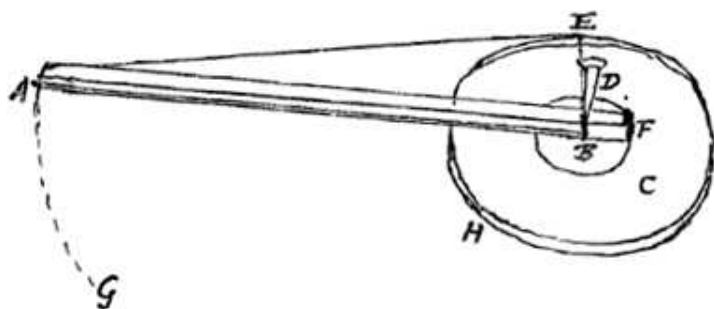

Figure 5.2.2: Huygens [1888-1950], vol. 11, p. 216.

The instrument described by Huygens and depicted in the figure 5.2.2, according to the original drawing, works as follows. It is composed of a flat circular disk (called "cylinder" by Huygens, and denoted by the letter C in the original figure) on which lies a concentric smaller cylinder ("cylindrus minor" in Huygens' parlance). A ruler FA is fixed to the center of its basis, call it B . A string ("chorda") winds around the circumference of the larger cylinder, and is tied to points A and B . At the extremity of the string a tracing pin is attached (BD in the figure). The pin can freely glide along AF (imagine, for example, that the pin can move along a groove dug in the ruler FA), and AF can turn around B , together with the smaller cylinder. Since points A , B and E (an arbitrary point on the basis of the first cylinder) are tightly connected by a string, when FA turns around B , the string unwraps upon the circular basis, and the pin BD is pushed forward in the groove. The spiral is traced by B : in fact, this point is contrived to move uniformly ("aequabili motu" remarks Huygens) along FA , which rotates around B .

Even if this sketch dates from the year of Descartes' death, H. Bos (Bos [2001], p. 348) points out that, being an early mathematical piece by Huygens, it might have been inspired by Descartes himself, who was one of Huygens' early acquaintances.

Since this evidence is tenuous, we wonder whether similar mechanisms were known to practitioners before 1637. The answer is positive: Daniel Schwenter, for instance, in his *Geometriae Practicae novae libri IV* (1625) offers a construction of the spiral by means of a thread, that presents the same functioning of Huygens' device, although its description is not as detailed as the latter. The mechanism described by Schwenter is formed by a thread or string, whose extremity is connected to a tracing pin and the other to a cylinder. As the cylinder turns, the thread, remaining in tension, wraps around the cylinder, and its extremity traces a spiral, because the tracing pin moves uniformly along

a rotating radius.³²

From the descriptions given above, we can single out a similar process at work in the mechanisms for the tracing of the spiral and in the one for the construction of the helix, described in Guido Ubaldo's book on mechanics. In all these cases, the tracing of the desired curve involves the twisting of a concrete object like a thread or a triangular wedge. Hence, the possibility of these constructions can be seen to depend, as a necessary condition, on the physical properties of the objects involved in their genesis: the triangular wedge in Guido Ubaldo's and the threads in Huygens' or Schwenter's mechanisms are to be imagined as composed of a material that can be suitably twisted in order to fit in the construction protocol.³³

But the physical properties of these devices also constrain the very process of construction. For instance, the number of spires that one can trace with Huygens' or Schwenter's device depends on the length of the thread, whereas, in Guido Ubaldo's procedure, the number of twists in the helix depends on the height of the given cylinder. Such insistence on the material aspect of the instruments involved in curve construction is not surprising in the authors discussed in this section: indeed, the constructions I have illustrated in the previous lines belong to treatises of mechanics or practical geometry, where practical elements usually overshadowed any concern over theoretical questions.

Yet I venture to conjecture that the apparatus for the construction of mechanical curves, presented in this section, did not have a mere practical import for early modern authors who promoted and discussed them. For instance, according to the witness of David Rivault, a French literate and mathematician, author of a momentous commented edition of Archimedes' works,³⁴ an instrument called 'helixograph compass' was used in order to construct the archimedean spiral "by a rotation in the manner of a vine leaf" ("*pampini modo circumductio*", Rivault [1615], p. 380), in such a way that:

³²Ulivi [1990], p. 539. Schwenter's mechanism was probably not original. According to E. Ulivi, in fact, constructions of the spiral involving the torsion of strings were known in XVIth century, as a brief remark in Besson's *Theatrum instrumentorum*, a work published in 1578, attests. The latter mentions the existence of constructions obtained "*funiculi circumpliatione*" (Besson [1578], p. 6), without giving examples. Another interesting, although brief remark, can be found in D. Rivault's Commentary to Archimedes' *Spirals* (more on this below).

³³Cf. Panza [2011], p. 81.

³⁴The edition of Archimedes prepared by Rivault was published in 1615 with the title: *Opera quae extant. Novis demonstrationibus Commentariisque illustrata* (see Rivault [1615]). This edition remained influential for the whole XVIIth century. As a sign of its circulation, let us remark that the first german edition of Archimedes' collected works: *Des unvergleichlichen Archimedis Kunst-Bücher oder heutigs Tags befindliche Schriften*, edited by Sturm and published in 1670, was still based on Rivault's edition.

Qui volet defendere Helixographi circini operationem, quae unica revolutione opponet communem διαβήτης materiam etiam constare, manu duci, oculis videi, sensu tangi: nec propterea mechanicas ipsius censi operationes, admitti eas a Geometris: licet propterea mathematicam fidem etiam illi ἐλιξογράφῳ praestare.³⁵

Although this passage is of difficult interpretation, yet we can still glean from Rivault's words the conclusion that a device for constructing the spiral (possibly a model analogous to those devised by Schwenter and by Huygens) was judged, in the opinion of some unspecified practitioners, as geometrical as the common compass. Even if the passage does not tell it overtly, those practitioners might have also grounded, on the alleged geometrical character of their compass, the geometrical nature of the curve traced by its application, like the spiral.³⁶

5.2.3 Pointwise construction of mechanical curves

Rivault's pointwise construction

A second technique, frequently employed in order to describe curves of the third kind (according to Pappus' classification) without appeal to motions, consisted in constructing - by legitimate instruments like the ruler and the compass - a net of points on the curve and, in order to describe it, interpolating these points by the continuous tracing of the pen.

A notable example among the numerous ones which flourished during XVIth and early XVIIth century³⁷ concerns the construction of the archimedean spiral, and it is expounded by the aforementioned David Rivault. It can be found in a commentary to the latin version of Archimedes' treatise *On Spirals* translated by Rivault himself.³⁸

³⁵Rivault [1615], p. 380: "Some would like to defend the operation of the helixograph compass, which by a sole rotation shows that [like] the common compass it is made of matter, guided by the hand, seen by the eyes, touched by the senses; and it does not follow that its operations are judged mechanical, but they are admitted by geometers, in virtue of which we can bestow mathematical reliability upon such helixograph compass".

³⁶I have not been able to find other occurrences of such a 'helixograph compass' in the corpus of XVIth and XVIIth century mathematics, in order to test my conjecture. I envisage to undertake further investigations in this direction in future works.

³⁷This manner of construction became well-known and occasionally criticized between late XVIth and early XVIIth century, as the survey in Bos [2001] (in particular, p. 75, and *sparsim* chapter 9, chapter 11 and 12) confirms.

³⁸See Rivault [1615], p. 339-405.

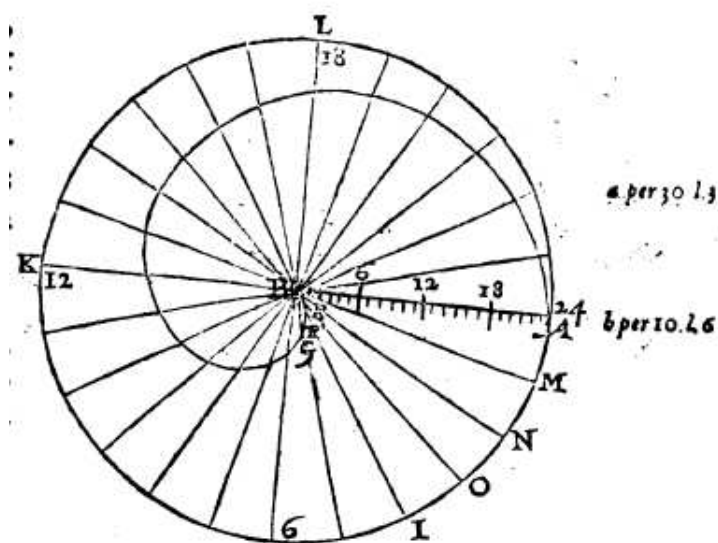

Figure 5.2.3: Rivault [1615], p. 347.

As we recall from chapter 2, section 2.3.3, the spiral (or, more precisely, the first turn of a spiral) is defined at the outset of Archimedes' treatise, as a curve resulting from the motion of a point along a diameter of a given circle, while the said diameter executes one complete revolution. Rivault translates and comments this definition, adding that a similar one can be found in Pappus' *Collection*, Book 4, proposition 19.³⁹

Like Pappus (and unlike Archimedes), Rivault proposes the problem of describing a spiral ("*spiralem describere*") within a given circle, and solve it by a pointwise construction of the curve. Rivault's construction protocol can be thus sketched.⁴⁰

- Trace a circle γ with radius BA (fig. 5.2.3).
- Divide γ into n equal sections ("*multas partes aequales*"). In the diagram that exemplifies Rivault's text, the circle has been divided in 24 parts (see 5.2.3, which reproduces the original, in Rivault [1615], p. 347). Such a choice is plausibly motivated by the fact that a regular polygon of 24 sides is constructible with ruler and compass. Obviously, not all divisions of the circle into equal parts can be done in an elementary way: Rivault probably knew that the division in seven or nine

³⁹Rivault [1615], p. 347.

⁴⁰Rivault [1615], p. 347.

points, for instance, requires higher curves, but no considerations with this respect are to be found in Rivault's commentary.

- As a next step, divide the radius BA into the same number of parts. This operation can be effectuated by ruler and compass, for any number of divisions.
- Name the points thus traced from B to A , by an increasing sequence of numbers: $1, 2, 3, \dots$ (in the diagram, the sequence terminates with point 24).
- With centre B , trace circles with radii: $B1, B2, B3, \dots BA$ (where $A \equiv 24$).
- Starting from BA , and proceeding clockwise, mark the intersection point between the circle with radius $B1$ and the first radius of γ encountered (namely BM). Then proceed in the same way, and mark the intersection point between the circle with radius $B2$ and the second radius BN .

Iterating the same procedure, a net of points can be constructed, which belong to a spiral (as Rivault notices, the more parts the angle is divided, the more precisely the pointwise description of the spiral will approximate its continuous shape). The correctness of Rivault's procedure can be inferred from the the very symptom of the spiral. Indeed, let s_1 and s_2 be the distances traversed, in times t_1 and t_2 , by the translating point from A to B . Then, let \widehat{a}_1 and \widehat{a}_2 be the distances covered, in the same times t_1 and t_2 , by the radius starting its rotation from the initial position BA . Since the twin motions are supposed uniform, the following proportion will ensue: $s_1 : s_2 = \widehat{a}_1 : \widehat{a}_2 = t_1 : t_2$. Hence, any couple of points on the spiral will thus satisfy the proportion: $s_1 : s_2 = \widehat{a}_1 : \widehat{a}_2$, where s_1 and s_2 stand for the distances of the points from the centre, and $\widehat{a}_1, \widehat{a}_2$ represent the angular distances from the points to BA . It can be immediately verified that all the points constructed by Rivault's protocol satisfy this condition. Therefore, these points lie on a spiral traced by a translating point on a segment BA , which pivots around its centre B , both motions occurring uniformly.

Epistemic considerations

I notice that the protocol just illustrated does not give a continuous tracing of the spiral, but only a net of points through which the curve had to pass. I argue that Rivault may have judged his pointwise description of the spiral as a source of legitimation for the continuous construction of the curve, given by Archimedes and Pappus (see chapter 2). Firstly, Rivault's pointwise description of the spiral defines the curve avoiding the

petitio principii, pointed out originally by Sporus (see chapter 2, sec. 2.3.2), consisting in assuming the ratio between the rotational and translational motions, and therefore the rectification of the circle. Moreover, the pointwise construction can be obtained solely by ruler and compass (provided the circle is divided in a number of parts constructible by Euclidean means). Thirdly, and finally, the pointwise description can be performed in a more expedient way than by recourse to motions, since it does not require to impose specific conditions on the velocities, that are difficult to control during the practical tracing of the curve, or during its tracing in the imagination.

I remark that Rivault dedicates interesting considerations to the difficulties inherent to the generation of the spiral by twin motions. In particular, Rivault points to a difference, that we may define of epistemic order, between the genesis of the circle according to Euclidean clauses, that he deems fully geometrical, and the construction of the spiral:

Circulum mens breviter concipit, quae in apprehendenda helica turbatur.
Motus simplex familiaris est, atque hoc circulis constat: mixtus vero seu compositus quo voluta oritur, remotior est a communi conceptu, difficilisque phantasiae inhaeret, eoque facilius in errorem est praeceptus. ⁴¹

The core difference between the construction of the circle and that of the spiral is based, in Rivault's narration, on the different capacity of representing the genesis of each curve to the mind. Rivault takes for granted that, while the action that allows him to trace a circle can be easily cognized, since it consists in one, simple and familiar motion, the construction of the spiral depends on the composition of two motions, namely a rotation and a translation, occurring at the same time and with uniform speed. Hence, Rivault concludes, the process which generates a spiral is not as transparent to the mind as the generation of the circle. On this ground, he states that a curve like the spiral appears somewhat mechanical ("*mechanicum redoleret*").

Even if some may defend the geometrical nature of a spiral on the ground of its generation by instruments, like the "*circinus helixographus*" discussed above,⁴² Rivault maintains

⁴¹Rivault [1615], p. 381: "The mind can quickly (*breviter*) cognize the circle while it is troubled in cognizing the spiral (*helica*). A simple motion is familiar, and the circle consists of this: but the mixed or composed one, from which the spiral is engendered, is distant from the common opinion (*a communi conceptu*), and it remains fixed with difficulty in our imagination, and for this it is more liable to error".

⁴²Rivault [1615], p. 380.

that a curve thus traced does not become more perspicuous to us, because it is still engendered in a complex manner:

At indignum est mathematica certitudine quodcumque primo intuitu non patet vel perspicua rationcinatione non elicitur, vel perplexum est, vel mixtum, vel compositione sua erroneum.⁴³

In conclusion, it is possible that Rivault regarded his own pointwise construction as closer to mathematical certainty, because it eliminates both the reference to uncontrollable motions and the recourse to complex instruments.

Whether the above reflections were developed by Rivault in connection with an original philosophy of mathematics, I am not competent to decide. However, I can still venture the hypothesis that Rivault envisaged the actions of the geometer (in terms of construction of curves and figures) as deploying in the abstract space of the imagination, which might be thought as a sort of mental analogue of the paper on which geometrical constructions and diagrams are drawn. Exact constructions would thus be perspicuous ones (notice: the word '*perspicuus*' is used by Rivault himself in the excerpt reproduced above), namely constructions which appealed to simple and familiar actions (i. e. the case of the circle) and that enjoy, consequently, immediate evidence. Similar views can be encountered in the reflection of other mathematicians writing around the same period,⁴⁴ so that it is not implausible to interpret Rivault's claims within this constellation of ideas.

Clavius' pointwise construction of the quadratrix

The second pointwise construction I want to consider regards another curve discussed in Pappus' *Collection*, namely the quadratrix. The pointwise construction of this curve was elaborated by the Jesuit mathematician Christophorus Clavius around 1589, on the aftermath of the publication of Commandinus' first edition of Pappus' *Collection*. This

⁴³Rivault [1615], p. 381: "But it is not worth of mathematical certainty anything that is not evident at first sight, or is not made manifest through a perspicuous reasoning, or it is intricate, or embroiled, or vague because of its intricacy".

⁴⁴In his Bos [2001], for instance, Henk Bos mentions at least two geometers, Johannes Molther and Willebrod Snellius, who held similar opinions on the mental status of geometrical constructions. As Bos remarks: "Molther stressed that motion was very common within pure geometry; a line was generated by motion of a point; spheres, cones and cylinders were generated by the motions of circles and straight lines (...) constructions still had to be performed in the mind by an inner sense, and this was done by procedures idealized from the actual physical construction procedures" (Bos [2001], p. 200), whereas Snellius: "stated that motion in pure geometry was imaginary in the sense that it was conceived in the mind of the geometer" (*ibid.*).

construction appeared for the first time in an appendix to the second edition of *Euclidis elementorum libri XV* (1589) and in his *Geometria practica* (1606),⁴⁵ and enjoyed a considerable fortune in the subsequent years.⁴⁶

In his Euclid [1589], in particular, Clavius argued that if a truly geometrical construction of the quadratrix were given, it could profitably extend the number of curves fully acceptable in geometry, and thus fulfill the ambitious project of solving geometrically the circle-squaring problem, the general angle division, and the construction of regular polygons of any number of sides, namely the main problems in want of a solution by the time of his writing.⁴⁷ Arguably, one may suppose that in Clavius' view the problem on which mathematicians should focus their effort was not to find a new construction for the squaring of the circle, but to give a description of the quadratrix which may comply with the requirements of mathematical acceptability in force within Clavius' conception of geometry.

Indeed Clavius' fundamental contribution to the study of the quadratrix consisted in offering a way to circumvent the difficulties inherent in Pappus' construction of the curve through movable axes:

Quamquam autem praedicti auctores huiusmodi lineam conentur describere per duos motus imaginarios duarum rectorum, qua in re principium petunt, ut propterea a Pappo rejiciatur, tamquam inutilis, et qua describi non possit, nos tamen eam sine illis motibus Geometrice describemus per inventionem quotius punctorum, per quae duci debeat, quaemadmodum in descriptionibus conicarum sectionum fieri solet.⁴⁸

⁴⁵Clavius' construction can be found in the appendix to Euclid [1589]: "De mirabili Natura lineae cuiusdam inflexae per quam et in circulo figura quotlibet laterum aequalium inscribitur, & circulum quadratur & plura alia scitu iucundissima perficiuntur". The study on the quadratrix, in particular, was incorporated in (Clavius [1604], p. 320-329). Both the *Geometria Practica* and the *Elementorum libri XV* were reprinted in Clavius' mathematical works (1611-1612). See also Bos [2001], p. 160 and Mancosu [1999], p. 74, for an overview of Clavius' discussion on the quadratrix, to which I am especially indebted.

⁴⁶Garibaldi [1996], p. 81.

⁴⁷Euclid [1589], p. 894.

⁴⁸Euclid [1589], p. 894: "But although the said authors [i.e. Hippias and Dinostratus, among the ancients] try to describe a curve of this sort [namely, the quadratrix] via two imaginary motions of two straight lines, which beg the question, so that, henceforth, the curve is refused by Pappus as useless and for this reason impossible to be described, we describe this line geometrically instead, without these motions, by the invention of so many points, through which it can be traced, in the same way as it happens in the description of conic sections".

Clavius wrote these considerations under the spur of the recent publication of Commandinus' translation of the *Collection*, occurred in 1588, and specifically after his attentive reading of book IV. We find indeed resumed, in the above passage, the objections to the generation of the quadratrix that can be traced in Pappus' account too (Book IV, propositions 26). Firstly, Clavius recalls that the quadratrix is described by a couple of motions which 'beg the question'. Clavius revives here the objection originally attributed to Sporus:⁴⁹ a particular quadratrix cannot be described via the appeal to a couple of motions, according to the protocol set out in *Collectio*, IV, 26, unless one knows beforehand the ratio between the velocities of the tracing motions, and ultimately the ratio between diameter and circumference. Clavius maintains that the quadratrix, as described in the *Collection*, is useless, because it presupposes the very problem that it should solve.⁵⁰

But Clavius had clearly in mind also the other objection originally advanced by Sporus, concerning the fact that the foot of the quadratrix cannot be determined, when the curve is described by a couple of motions. Clavius indeed points out to the difficulty concerning the construction of the terminal point of the quadratrix when he underlines that it: "cannot be found geometrically, because all intersections of the lines will at that moment cease".⁵¹

A new description of the quadratrix is thus advanced by Clavius:

Quare nos Geometrice eandem lineam Quadratricem describemus hoc modo. Arcus BD in quotius partes aequales dividatur, & latus utrum AD, BC in totidem aequales partes. Facillima divisio erit, si et arcus DB et utrumque latus AD, BC secetur primum bifariam, deinde utraque semissis iterum bifariam, etc., ita deinceps, quantum libuerit. Quo autem plures existerint divisiones, eo accuratius linea describetur. . .⁵²

⁴⁹Clavius' reading of *Collection*, Book IV, 26 is however vitiated by Commandinus' interpolation of the proper name Sporus with the verb "*spero*", hence there is no mention of the ancient geometer who criticized the generation of the quadratrix.

⁵⁰Similar considerations return one page later, in Euclid [1589], p. 895. I recall that this objection holds only if we want to construct a particular quadratrix, for instance inscribed in a given circle (see chapter 1). To my knowledge, Clavius makes no considerations on this point.

⁵¹Euclid [1589], p. 896: "inveniri Geometrice non potest, cum ibi omnis sectio rectorum cesset".

⁵²Euclid [1589], p. 895: "Thus, we describe geometrically the quadratrix line in this way: Let the arc *BD* be divided in a number of equal parts, and either side *AD* or *BG* be divided in the same number of equal parts. This division will be very easy, if the arc *DB* and one of the two sides *AD*, *BG* are firstly bisected, then any half side will be again divided in two, and so on, as much as we like. The more divisions will be, the more accurately will the line be described. . .".

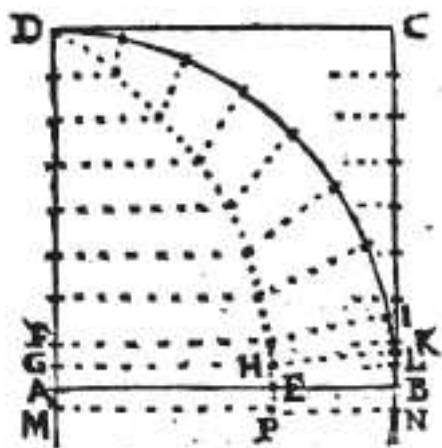

Figure 5.2.4: Euclid [1589], p. 895.

The protocol detailed in the passage can be thus schematized:

- In a given circle with radius AD , divide AD and the arc \widehat{BD} into the same number of equal parts (this operation can be accomplished by ruler and compass).
- From the points of division so obtained on AD and \widehat{BD} , let the parallels to AB and the radii be traced, respectively.
- The intersection points of corresponding segments will lie on the quadratrix.

The proof is immediate, since the quadratrix is the sectrix curve of the arc corresponding to a quarter of the circumference (this property is implicit in the very symptoma of the quadratrix, as reported by Pappus. Cf. chapter 2, section 2.3.2), so that all points constructed in the way explained by Clavius in the above passage lie on that curve.

In this way, Clavius concluded that his pointwise description of the quadratrix was more geometrical than the construction of Dinostratus, as it possessed the advantage of determining the curve without the dubious appeal to a pair of independent motions.⁵³

⁵³As we read in Euclid [1589], p. 897: "esse autem hanc lineam inflexam DE a nobis per puncta descriptam geometricè eandem, quam Dinostratus et Nicomedes per duos illos motus imaginarios describi concipiebat, perspicuum est" ("It is clear that this curve DE , described by us geometrically point by point, is the same that Dinostratus and Nicomedes conceived described by these two imaginary motions").

On the other hand, the pointwise construction of the quadratrix could not secure the continuous tracing of the curve. Clavius was certainly aware of the discrete character of his pointwise description, as he recommended that one should carry out a continuous description of the curve:

Per ea puncta Quadratrix linea congruenter ducenda est, ita ut not sit sinuosa, sed aequabiliter semper progrediatur nullum efficiens gibbum, aut angulum alicubi, qualis est linea inflexa DE , secans semidiametrum AB in E .⁵⁴

According to this passage, the quadratrix should be traced ("*duci*") by connecting all the points constructed by ruler and compass with a smooth continuous line, that does not make bents or angles anywhere. He even recommended to increase the number of divisions in order to obtain a more accurate tracing of this curve.⁵⁵ It is not clear, though, by which means the continuous tracing of the quadratrix should be effectuated. Probably Clavius was confident that the continuity of the quadratrix could be ensured by the classical generation via two motions. Hence, the pointwise construction offered by Clavius would legitimate the soundness of Dinostratus' construction, but it would be no substitute for the latter.

A second difficulty connected with Clavius' pointwise construction of the quadratrix concerns the fact that, even if it could deploy, through continual bisections of the radius and the arc, an infinite collection of points belonging to the quadratrix, it could not construct any point among those on the quadratrix. In particular, it could not construct the intersection point with the horizontal axis (point E in figure 5.2.3). But Clavius trusted that his method offered an accurate way of tracing the whole curve, included point E , and consequently could circumvent the second objection raised by Sporus (or Pappus himself, in Clavius' reading of Commandinus' version).

In order to determine point E , Clavius illustrated the following, special procedure:

- Bisect the arc BD and the segment AD repeatedly, until obtaining a very small ("*perexigua*", in Clavius' words) segment AF and its corresponding arc \widehat{BI} .
- Bisect segments AF , and call G the midpoint of AF .

⁵⁴Euclid [1589], p. 896: "The Quadratrix must be traced through these points in a fitly way, so that it is not wavy (*sinuosa*), but proceeds uniformly (*aequabiliter*), without making any bent (*gibbum*), or angle anywhere, like it is the curved line DE , which cuts the semi-diameter AB in point E ".

⁵⁵See for instance Euclid [1589], p. 895: "Quo autem plures existerint divisiones, eo accuratius linea describetur" ("the more divisions will be made, the more accurately the curve will be described").

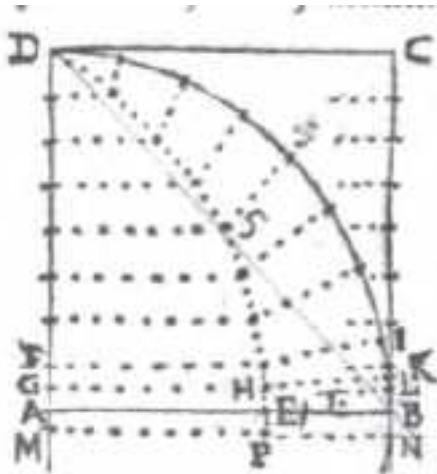

Figure 5.2.5: Euclid [1589], p. 896.

- Construct point M , symmetrical of G with respect to A . On point B , and perpendicular to AB , construct a segment $BL = AG$. Then construct a point N , symmetrical of L with respect to B . Since $GA = MA = BL = BN$ by construction, segments GL and MN will be parallel and equal.
- Bisect the arc \widehat{BJ} , and call K the midpoint of the arc.
- The intersection between segment GL and AK will yield a point H , belonging by construction to the quadratrix.
- Construct point P , symmetric of H with respect to the axis AB (the point will lie on MN) and connect with a continuous tracing all points thus constructed, included point P .

Clavius assumed (implicitly) that the curve joining points H and P , lying on opposite sides with respect to the axis AB , would cut AB in a point which coincides with E , below "a noticeable error, that is, an error that could be perceived by the senses".⁵⁶

With hindsight, we might be tempted to interpret Clavius' construction as suggesting a geometric representation of a limiting process, in the following way.⁵⁷ Consider the

⁵⁶"Sine notabili errore, qui scilicet sub sensum cadat." Euclid [1589], p. 896.

⁵⁷as we can recognize from the model offered in (Becker [1957], p. 97-98) in order to determine the foot of the quadratrix point E as the limit of two converging sequences through an iterative construction

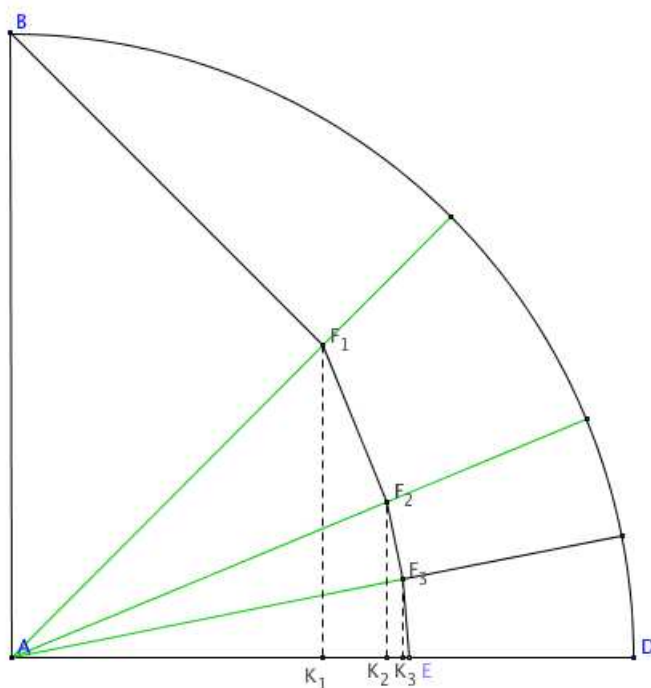

Figure 5.2.6: Clavius' pointwise construction.

quadrant of side AB (fig. 5.2.3), let points $F_1, F_2 \dots F_n \dots$ be constructed according to Clavius' protocol: point F_1 will be obtained by bisecting the angle BAD and the side AB ; the chain of points F_n will be obtained by successive dichotomies of the angle and the side.

Let the perpendiculars $F_1K_1, F_2K_2 \dots F_nK_n \dots$ to the line AD be dropped. As n increases, points F_n get closer and closer to the intersection point E , that we assume to exist by continuity, without 'touching' it. Similarly, as n increases, it is clear from the diagram that also points K_n tend to point E . Thus, two sequences of points (or segments, taking A and B , respectively, as their origins) have been constructed in order to approach E from below and from above. It is therefore implicit, in Clavius' procedure, the determination of point E as a limit of two converging sequences of points.

is studied, for instance, Becker, however, omits to mention Clavius as a predecessor of this technique.

Moreover, it can be easily proved that segments $F_n F_{n+1}$, obtained by joining two successive points constructed by Clavius' method are perpendicular to the corresponding segments AF_{n+1} . Let us take, for instance, the segment $F_1 F_2$ in figure 5.2.3. Let us remark that the triangle $AF_1 F_2$ can be considered the half of an isosceles triangle, having vertex in A , one side AF_1 and the other side lying on AD (in fact the angles DAF_2 and $F_2 AF_1$ are equal, in virtue of Clavius' construction). Therefore AF_2 will bisect the base of the isosceles triangle at point F_2 , and will be perpendicular to $F_1 F_2$. The same result holds, without loss of generality, for successive segments $F_n F_{n+1}$.

On this ground, using trigonometry, and setting $AB = 1$, we will have that: $AF_1 = \cos \frac{\pi}{4}$, $AF_2 = AF_1 \cos \frac{\pi}{8} = \cos \frac{\pi}{4} \cos \frac{\pi}{8}$, $AF_3 = AF_2 \cos \frac{\pi}{16} = \cos \frac{\pi}{4} \cos \frac{\pi}{8} \cos \frac{\pi}{16}$, and so on. After n bisections we will have:

$$AF_n = AF_{n-1} \cos \frac{\pi}{2^{n+1}} = \cos \frac{\pi}{4} \cos \frac{\pi}{8} \cos \frac{\pi}{16} \dots \cos \frac{\pi}{2^{n+1}}.$$

In an analogous way, we can express segments $AK_1, AK_2 \dots, AK_n$ as: $AK_1 = AF_1 \cos \frac{\pi}{4} = \cos^2 \frac{\pi}{4}$, $AK_2 = AK_1 \cos \frac{\pi}{8} = \cos \frac{\pi}{4} \cos^2 \frac{\pi}{8}$, $AK_3 = AF_3 \cos \frac{\pi}{16} = \cos \frac{\pi}{4} \cos \frac{\pi}{8} \cos^2 \frac{\pi}{16}$, and $AK_n = AF_n \cos \frac{\pi}{2^{n+1}} = \cos \frac{\pi}{4} \cos \frac{\pi}{8} \cos \frac{\pi}{16} \dots \cos^2 \frac{\pi}{2^{n+1}}$. Clavius' geometric construction shows that point E is squeezed in the interval $AF_n - AK_n$, namely:⁵⁸

$$AF_n - AK_n = \cos \frac{\pi}{4} \cos \frac{\pi}{8} \dots \cos \frac{\pi}{2^{n+1}} (1 - \cos \frac{\pi}{2^{n+1}}) < 1 - \cos \frac{\pi}{2^{n+1}}.$$

Hence the difference between segments AF_n and AK_n is smaller than the difference $1 - \cos \frac{\pi}{2^{n+1}}$, which tends to zero as n grows. This reconstruction can justify why Clavius was confident that his procedure could determine point E "*sine notabili errore*", the more one proceeds in subdividing the side and the angle. However, it should be pointed out that Clavius did not explicate, in the Commentary to Euclid or in other works, a notion of limit akin to the modern one. In other words, he did not (at least explicitly) define point E as the limit point of two converging sequences of points, in the sense that, for any chosen interval $AF_n - AK_n$, there exists a couple of points (F_{n+1}, K_{n+1}) such that the interval $AF_{n+1} - AK_{n+1}$ is smaller than $AF_n - AK_n$.

⁵⁸Becker [1957], p. 98.

The discussion of the quadratrix contained in the second edition of his Commentary to Euclid's *Elements* raised a long and lively debate, mainly centered around the geometrical character of the construction there proposed, and around the acceptability of the quadratrix as a geometrical curve.

We can remark that the latter claim is not fully and clearly justified by Clavius: if the pointwise description of the quadratrix avoids any appeal to motions, nevertheless it does not warrant the continuous tracing of this curve. Moreover, Clavius' construction of the foot of the quadratrix contains some obscurities too, as some of his early readers, like Van Roomen and Lansbergen did not fail to remark. For instance, Van Roomen wrote to Clavius in 1592, observing that his construction was simply of "no help in calculation",⁵⁹ and Lansbergen, in his *Cyclometriae libri duo* (1616), noticed that Clavius' effort was of "no significance" ("*conatu irrito*"), since the termination of the quadratrix is not exactly captured by his procedure.⁶⁰

As a response to these and other critiques, Clavius later modified his views on the geometrical nature of the quadratrix. Probably aware of the difficulties inherent to the pointwise construction of this curve, in the 1603 edition of his *Elements* he published the appendix on the quadratrix with a small, but significant correction: he stated in fact that his procedure allowed to trace the eponymous curve not "*geometricè*" but "*quodammodo geometricè*", namely "somewhat geometrically". One year later, in 1604, Clavius published the *Geometria practica*. We find, at the end of book VII, dedicated to isoperimetric problems, an appendix: "*De circulo per lineas quadrando*", where Clavius illustrates several methods for solving the circle-squaring problem, and manifests his conviction that the quadratrix constitutes the most accurate way.⁶¹

Conclusively, it seems that Clavius did not abandon his conviction that the quadratrix, redefined according to his own description, could be a curve that we might accept as geometrical, even if it did not possess the same character of exactness of the circle and the straight line. In summary, the pointwise construction of this mechanical curve might represent, in Clavius' viewpoint, a satisfactory compromise between practical accuracy

⁵⁹See Bos [2001], p. 165.

⁶⁰It did not escape to Lansbergen that Clavius was well aware of this flaw: "... Clavius ipse fateri cogitur, ipsius tetragonisouses finis eo modo numquam deprehenditur" (van Lansbergen [1616], p. 107).

⁶¹"Haec via licet ad Geometricè inveniendum punctum quoddam nonnihil in ea desideretur, accuratior tam est omnibus alijs quas hactenus videre potui" (Clavius [1604], p.320). In the subsequent section, Clavius illustrates the pointwise construction of the quadratrix, reproducing the protocol and, almost literally, the text of his 1589 and 1603 editions.

and geometrical exactness. The evolution of Clavius' ideas on the quadratrix, and especially his final deliberations on the quasi-geometrical status of this curve, make Bos' suggestion plausible, according to which Clavius: "took practical precision as guideline for deciding on geometrical exactness" (Bos [2001], p. 166).

5.3 Descartes' appraisal of string-based mechanisms and pointwise constructions

In this section, I will provide evidence that Descartes was not only acquainted with the two modes for constructing mechanical curves presented in the foregoing sections, namely constructions performed by the twisting of a straight line into a circular arc and pointwise construction, but that he critically discussed, compared with analogous constructions for geometrical curves and eventually discarded the methods for describing mechanical curves as methods that ought to be truly ranged among mechanics, where, Descartes glossed, only: "la justesse des oeuvres qui sortent de la main est désirée".⁶²

Acceptable and non-acceptable uses of strings

Let us revert to the construction of the helix presented in Guido Ubaldo's work or the description of the spiral given by Daniel Schwenter. Evidence that Descartes might be acquainted with either of these mechanisms comes from the following controversial passage, taken from a letter, evoked above, written by Descartes to Mersenne in November 1629. As we have seen, the letter mentions a curve called helix ("la ligne hélice"), described:

... par le moyen d'un filet, car tournant un filet de biais autour du cylindre, il décrit justement cete ligne là, mais on peut avec le mesme filet quarrer le cercle si bien que cela ne nous donne rien de nouveau en Geometrie.⁶³

As I have also explained above, scholars are divided on the exact significance of Descartes's description. Arana and Mancosu claim, in Mancosu and Arana [2010], that this passage relates the construction of a cylindrical helix, obtained through "a thread turning obliquely around a cylinder", a procedure that we recognize similar or analogous to the one expounded in the *Mechanicorum* of Guido Ubaldo.

⁶²Descartes [1897-1913], vol. 6, p. 389.

⁶³Descartes [1897-1913], vol. 1, p. 71.

I recall, on the other hand, that the term helix ("hélice", in french, and "helica" in latin) could be used in XVIth and XVIIth to denote either the cylindrical helix, as in the previous interpretation, or the archimedean spiral. On the ground of this attested ambiguity, the line obtained through "a thread turning obliquely around a cylinder" has been interpreted as the archimedean spiral: Descartes' concise description may be immediately referred to Huygens' mechanism (see Bos [2001], p. 348) or more likely, I suggest, to the mechanism presented by Schwenter for the construction of the Archimedean spiral.

It is not my purpose to assess here whether Descartes was referring, in his 1629 letter, to the helix or to the archimedean spiral. I will merely confine myself to remarking the following: the letter suggests that Descartes was acquainted, by 1629, with such mechanisms for the tracing of mechanical curves based on the twisting of strings or threads.⁶⁴

Another indication of such acquaintance shines through the text of *La Géométrie*. In fact Descartes carefully distinguishes, in a section of the second book eloquently titled: "quelles sont aussy celles qu'on décrit avec une corde, qui peuvent y estre receues" ("which are the curves described with a string, that can be received in geometry", Descartes [1897-1913], vol. 6, p. 412), two modes of employing string-like constructions in geometry:

Et on n'en doit pas reietter non plus celles ou l'on se sert d'un fil, ou d'une corde repliée, pour determiner l'egalité ou la différence de deux ou plusieurs

⁶⁴An isolated remark that we find in the *Cogitationes Privatae* (written between 1619 and 1621) confirms this hypothesis, showing that Descartes has some knowledge of the use of strings for tracing curves already by the beginning of the 20s: "Si funis mathematicus admittatur, is erit communis mensura recti et obliqui. Verum dicimus hanc lineam admitti posse, sed a mechanicis tantum: ea scilicet ratione qua uti possumus statera ad aequandam cum pondere, vel nervo ad eandem comparandam cum sono; item spatio in facie horologii contento ad metiendum tempus, et similibus in quibus duo genera conferuntur" ("If a mathematical chord is admitted, there will be a common measure between the straight and the oblique. Indeed, we say that such line can be admitted, although only by practitioners of mechanics: for the very same reason on which we can use a lever to make it [namely a line] equal to a weight, or a string to compare the line with a sound, or the interval on the quadrant of a clock to measure time, and in similar things in which two different kinds are compared"). The expression "*funis mathematica*" (mathematical chord) may indeed refer to the process of adapting a segment onto an arc or a curved surface until the two coincide, the same process we detect in the genesis of the spiral and the helix by strings. Notice that Descartes confines such a process among mechanics ("we say that such line can be admitted, although only by practitioners of mechanics"). The reason, according to what the passage from the *Cogitationes* tells us, is that the operation engendered by a "mathematical chord" would stand on a par with the measuring of physical magnitudes, like the flow of time or the intensity of a sound, by means of geometrical magnitudes, like the line traced on the clock dial or the vibration of a chord, respectively. In all these cases -Descartes affirms - two "kinds" of magnitudes are conflated.

lignes droites qui peuvent estre tirées, de chasque point de la courbe qu'on cherche, a certains autres points, ou sur certaines autres lignes, a certains angles, ainsi que nous avons fait en la Dioptrique, pour expliquer l'Ellipse ou l'hyperbole. Car, encore qu'on n'y puisse recevoir aucunes lignes qui semblent à des cordes, c'est à dire qui deviennent tantost droites et tantost courbes, à cause que la proportion, qui est entre les droites et les courbes, n'est pas connue, et mesme ie croy ne le pouvant pas estre par les hommes, on ne pourroit rien conclure de là qui fust exact et assuré.⁶⁵

Descartes opposes here a legitimate and an illegitimate use of strings in curve construction. In the first case, strings are employed with the sole purpose of determining: "... the equality or difference of two or more straight lines drawn from each point of the required curve to certain other points, or making fixed angles to certain other lines". This use is exemplified by such procedures for the construction of conic sections through the so-called gardener's method, explained, for instance, in Descartes' *Dioptrique*.⁶⁶

Let us consider, for instance, the construction of the ellipse, offered there. Descartes starts by tying a string taut between two pins, coincident for instance with the two foci of the ellipse. Fixing a pencil against the string, it is sufficient to pull the taut string with the pencil, and then move this one in a large arc keeping the string taut.⁶⁷

These constructions can produce geometrical curves, although by means of a procedure different from the ones using geometrical linkages only, and it is judged by Descartes "very coarse and not very exact" ("fort grossière et peu exacte"), but sufficient in order to make the nature of the curve "better known". I note that the procedure presented in the *Dioptrique* respects the constraints on the legitimate use of strings specified in *La*

⁶⁵Descartes [1897-1913], vol. 6, p. 412. In order to better understand this important passage, I will report here the translation proposed by Smith and Latham: "Nor should we reject a method in which a string or loop of thread is used to determine the equality or difference of two or more straight lines drawn from each point of the required curve to certain other points, or making fixed angles to certain other lines. We have used this method in *La Dioptrique* in the discussion of the Ellipse and the Hyperbola. On the other hand, geometry should not include lines that are like strings, in that they are sometimes straight and sometimes curve, since the ratios between straight and curved lines are not known, and I believe cannot be discovered by human minds, and therefore no conclusion based upon such ratios can be accepted as rigorous and exact" (Descartes [1952], p. 91).

⁶⁶Let us recall that the *Discours de la méthode* was published along with three treatises: the *Dioptriques*, the *Météores*, the *Géométrie*. Although they were published together, the *Dioptriques* was probably already completed by 1630 (Descartes [1897-1913], vol. 1, p. 179).

⁶⁷An analogous procedure can be set up in order to construct an hyperbola. See Descartes [1897-1913], vol. 6, p. 166 and p. 176.

Géométrie: indeed, the strings employed for the construction of the ellipse (or the hyperbola) constrain every point on the curve in such a way that the sum (resp., difference, in the case of the hyperbola) of the segments joining it to the two pins is constant. Even if string-constructions of the ellipse and the hyperbola were not considered by Descartes on a par with constructions by geometrical linkages, yet Descartes might have recognized that strings are sometimes useful as heuristic devices, when they suggest how to conceive a geometrical linkage which could be employed for the construction of the curve at hand.⁶⁸

On the contrary, the illegitimate use of strings in geometry concerns those constructions employing cords which become "sometimes straight and sometimes curve". Moreover, Descartes explains that string-like lines are not receivable in geometry because the proportion between curves and straight lines cannot be exactly known.

It is not obvious to grasp how these two claims can go together. In order to venture an interpretation of Descartes' argument, I shall start by remarking that, although no examples of strings which are "sometimes straight and sometimes curve" appear in *La Géométrie*, Descartes might think of certain devices involved in the construction of curves. These could be, for instance, either the instruments tracing of spirals obtained through the devices described by Huygens or Schwenter, or the construction of the helix which, either in Pappus or in Guido Ubaldo, requires the twisting of a string or of a figure in order to trace the desired curve. As we have read in the foregoing section, it is plausible that Descartes was acquainted with these or analogous constructions, elaborated in the course of XVIth century and early XVIIth century, that involved the twisting of strings in order to trace mechanical curves.

I remark, on the ground of the analysis given in Panza [2011], that all these devices with which Descartes might have been familiar, and that involve the twisting of lines in order to construct the desired curves, are concrete instruments, since they are able to function thanks to specific physical properties of their components. The sources I have examined are quite eloquent on this point: both Guido Ubaldo and Huygens, for instance, insist on such physical characteristics of the objects entering their respective constructions, be it the material of which the triangular wedge is made, or the length of the chord wrapping on the cylinder.

⁶⁸Molland [1976], p. 42, Panza [2005] p. 84.

As a consequence, it can be noticed that the instruments or procedures for the tracing of mechanical curves were so designed to work only insofar as some forces are exerted by and upon their components, for instance in order to suitably bend strings and adapt them to curved surface: the constraints imposed to the construction of the spiral or the helix are undoubtedly of a mechanical nature.⁶⁹ These properties suggest an important difference with respect to the procedure involving the use of strings for the construction of conic sections. It is true that also in these cases concrete objects are employed, namely moving strings fixed to some pins. However, these strings can be conceived as instances of purely geometrical systems, in the sense that the only constraints to which the motions of these strings obey in order to trace an ellipse or a hyperbola can be expressed geometrically, as, in the case at hand, in terms of the sum or the difference between each point individuated by the moving strings and two fixed points.

From this discussion, we can venture the conclusion that, in the backdrop of a distinction between admissible and non admissible uses of strings deployed in *La Géométrie*, Descartes succeeded in isolating a certain type of curve constructions involving strings, whose behaviour was judged unacceptable in geometry, because it resulted from obvious mechanical constraints imposed on the traced curve.

However, the ground in order to discriminate between acceptable and unacceptable use of strings for curve-tracing devices does not seem immediately related to the reason explicitly invoked by Descartes, namely, the fact that the exact proportion between straight lines and curvilinear ones is unknown to men (a similar point is made in Panza [2011], p. 82). I suggest that Descartes might be convinced that, had the exact proportion between straight and curvilinear segments been known, the mechanical devices for the construction of the spiral or the helix could be replaced by geometrical linkages, in the same way in which, the construction of the conics by the strings can be easily substituted by constructions obtained via geometrical linkages. Hence, Descartes' peremptory denial that such a ratio could be exactly known would warrant the illegitimate status of those instruments, analyzed in the previous sections, employed for the tracing of the helix and the spiral.

In order to bear more evidence to this conjecture, I shall return later on an more precise interpretation of the expression 'exact proportion', crucial in Descartes' considerations.

⁶⁹Panza [2011], p. 83.

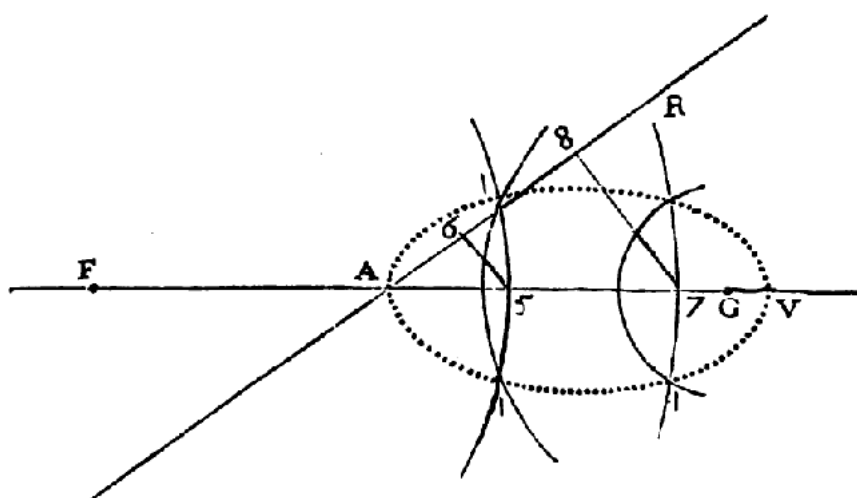

Figure 5.3.1: Descartes [1897-1913], vol. 6, p. 424.

Acceptable and non acceptable pointwise constructions

As explored in chapter 3, pointwise constructions play an important role in Descartes' *Géométrie*, for instance in connection with indeterminate problems, like Pappus' problem discussed in first and second books of the *Géométrie*. But, in Descartes' geometry, we come across pointwise constructions also independently from any occurrence of Pappus' problem: this is case of the ovals,⁷⁰ which are described both by a pointwise construction and by a method involving strings (this one analogous to the gardener's method employed in *La Dioptrique* for the construction of the ellipse and the hyperbola).

In the following lines I will deal only with one pointwise construction offered by Descartes, namely, the first one he presented in the treatise of 1637. Let FG and AR (fig. 5.3, in Descartes [1897-1913], vol. 6, p. 424.) be two lines intersecting at point A (between F and G) with a given angle. Let the ratio $\frac{AF}{AG}$ be given. Let then $AR = AG$. From point 5, arbitrarily taken on AG , let the circle with center F and radius $F5$ be traced. Let the segment 56 be traced, perpendicular to AR . Then, describe the circle with center in G and radius $R6$. The intersection points between circle $F5$ and circle $R6$ belong to the oval. By reiterating the same construction starting from other points arbitrarily

⁷⁰For a discussion of the ovals in Descartes' *Géométrie*, see Maronne [2010].

chosen on AG , we can provide a distribution of points on the same curve,⁷¹ which indeed describes one of the cartesian ovals. Changing a little this method Descartes could obtain, always by a pointwise construction, ovals with different shapes.⁷²

As for the constructions with strings, Descartes posited certain limits to the acceptability of pointwise constructions as legitimate descriptions of curves:

Ayant expliqué la façon de trouver une infinité de poins par ou elles passent, je pense avoir assés donné les moyens de les décrire. Mesme, il est a propos de remarquer qu'il y a grande difference entre cette façon de trouver plusieurs poins pour tracer une ligne courbe, et celle dont on se sert pour la spirale, et ses semblables. car par cete dernière on ne trouve pas indifféremment tous les points de la ligne qu'on cherche, mais seulement ceux qui peuvent être déterminés par quelque mesure plus simple, que celle qui est requise pour la composer, et ainsi a proprement parler, on ne trouve pas un de ses points, c'est à dire pas un de ceux qui luy sont tellement propres qu'ils ne puissent être trouvés que par elle.⁷³

In this passage, Descartes distinguished two types of pointwise constructions. A first type is the one in which any point belonging to a curve can be found. We may call this construction: 'generic pointwise construction'. Descartes also recognizes a second type, through which one can find only some points on a curve. This construction can be called: 'specific pointwise construction'.⁷⁴

The first case is exemplified by those curves which are expressed by finite polynomial equations of the form: $F(x, y) = 0$. In such cases, any point on the curve is in principle constructible geometrically, for instance by solving corresponding equations in one unknown. Also the construction of the ovals can be seen as an instantiation of the 'generic' pointwise construction evoked by Descartes: indeed it allows us to find any point belonging to that curve by following a finite ruler-and-compass stepwise procedure, starting from a point arbitrarily chosen on a straight line: in this sense any point on an oval "may be found at pleasure".

⁷¹In other terms, the curve so constructed is the locus formed by the vertex of a triangle FIG which contains three given collinear points A , B , C , and whose sides FI and FG have fixed length.

⁷²Descartes [1897-1913], vol. 6, p. 424-425.

⁷³Descartes [1897-1913], vol. 6, p. 411-412.

⁷⁴Both terms are employed in Bos [2001], p. 343-345.

Specific pointwise constructions concern, on the other hand, those constructions in which only some points on a curve can be found, determined by a "simpler measure" than the one employed for the construction of the curve. Although examples of specific pointwise constructions cannot be found in *La Géométrie*, our previous discussion on Clavius and Rivault reveals illuminating on this concern.

In particular, several studies agree on the opinion that Descartes, while discussing specific pointwise constructions, had in mind the very construction of the quadratrix offered by Clavius, in the appendix to book VI of his Commentary to Euclid's *Elements*.⁷⁵ In fact, we notice that the pointwise construction of the quadratrix given by Clavius does not yield indifferently any point belonging to the curve, but only those constructible by ruler and compass lying on a bisectrix of the angle $\frac{\pi}{2^n}$.

But we can also venture the hypothesis that Descartes was familiar with Rivault's pointwise description of the spiral, although I have not found any evidence proving a direct connection between the two authors. I point out, though, that similarly to Clavius' pointwise construction of the quadratrix, also Rivault's pointwise generation can be considered an instance of a specific pointwise construction, because it cannot determine any point on the spiral, but only those obtained by a previous division of the angle at the center of the circle into m equal parts. In particular, if $m = 2^n$, the pointwise construction of the spiral can be effectuated by ruler and compass, following exactly the same protocol adopted by Clavius, for the case of the quadratrix.

Descartes claims, in a correct and insightful way, that there is a 'great difference' between generic and specific pointwise constructions, but he does not claim that it is sufficient for a curve to be constructed in a specific pointwise way in order to be excluded from geometry. Whereas he certainly believes that a curve described through a generic pointwise

⁷⁵See in particular: Mancosu [1999], p. 74ff; Mancosu [2007], p. 116. The first piece of evidence proving Descartes' acquaintance with Clavius' study of the quadratrix is indirect: around 1614-1615, I. Beeckman, with whom Descartes would collaborate between 1618 and 1619, made a reference in his journal to Clavius' passage on the quadratrix, with respect to a problem in hydraulic (Beeckman [1939-1953], 1, p. 42-43). Since Descartes worked closely to Beeckman during the following years, it is plausible that he had heard of this construction. Direct evidence that Descartes knew about Clavius' pointwise construction is also given by the letter to Mersenne from 1629, quoted on previous occasions in this chapter. In this letter, Descartes is particularly critical about the pointwise description of the quadratrix and of the curve named "hélice" because, I quote: "encore qu'on puisse trouver une infinité de points par où passe l'hélice et la quadratrice, toutefois on ne peut trouver Geometriquement aucun des points qui sont nécessaires pour les effets desirés tant de l'une que de l'autre" (Descartes [1897-1913], vol. 1, p. 71).

construction is geometrical, such a belief does not obviously entail that if a curve is not described through a generic pointwise construction it is not constructible by geometric linkages, either.

5.4 Specification by genesis and specification by property: the case of mechanical curves

In the light of our previous considerations, Descartes' inquiries about methods for constructing curves, as they appear in *La Géométrie*, can be interpreted as a clear-cut criticism against the attempts to argue for the geometricity of certain curves, like the spiral and the quadratrix, on the ground of their constructibility by points or by means of strings. Acceptable methods, in Descartes' geometry, consisted either in constructions obtained by a geometric linkage, or in constructions obtained by generic pointwise constructions, or in construction effectuated by strings, employed only in order to determine: "... the equality or difference of two or more straight lines drawn from each point of the required curve to certain other points, or making fixed angles to certain other lines".

On the other hand, known procedures for describing the geometric nature of curves like the quadratrix, the spiral and the helix were crucially different from the standard methods just recalled, because they either made an essential appeal to independent motions, or had recourse to tracing devices or procedures which required the application of forces in order to properly function (like in those mechanisms in which strings are bent from straight to curve) or finally, they were based on specific pointwise constructions.

However, whereas Descartes had successfully succeeded in disqualifying attempts to legitimate the geometricity of mechanical curves, he still did not possess, solely on this ground, an effective criterion in order to discern geometrical from non-geometrical curves. Even if it is sufficient to describe a curve through a geometrical linkage in order to accept the curve in geometry, to provide a mechanical construction of a curve is not sufficient to show its mechanical nature. In brief, constructibility by geometric linkages provides necessary and sufficient conditions for accepting a curve as "geometrical", and certain necessary, though not sufficient conditions in order to sort out a curve as non-geometrical. Since identity conditions for curves are extensional, namely, they do not depend on how curves are constructed, we need a kind of impossibility proof unavailable to Descartes, and more generally to the mathematics of XVIIth century, in order to prove that a curve, exhibited

by a mechanical construction, is not receivable in geometry.⁷⁶

In Mancosu [1999], and more specifically in Mancosu [2007], P. Mancosu argues that the classification of several curves as mechanical is motivated by a local criterion, namely a criterion not necessarily shared by all curves that, with hindsight, we may want to rule out from geometry, but only by a subclass, certainly relevant with respect to Descartes' geometry, as it included most of the mechanical curves known to Descartes. On the ground of important textual evidence, this local criterion is identified with the possibility of solving the quadrature of the circle.⁷⁷

According to this suggestion, Descartes' decision of excluding such curves as the quadratrix, the spiral and, possibly, the cylindrical helix from geometry depended on his belief about the impossibility of knowing the exact proportion between straight and curved lines, that I have evoked above:

Car, encore qu'on n'y puisse recevoir aucunes lignes qui semblent à des chordes, c'est à dire qui deviennent tantost droites et tantost courbes, à cause que la proportion, qui est entre les droites et les courbes, n'est pas connue, et mesme ie croy ne le pouvant pas estre par les hommes, on ne pourroit rien conclure de là qui fust exact et assuré.⁷⁸

This belief involved a belief in the impossibility of solving geometrically the rectification of the circle, and therefore its quadrature too.

Since the precise significance of this belief and its role in the economy of the treatise have raised several interpretations in the scholarly literature, it is worth analyzing it

⁷⁶The point is discussed in Mancosu [2007], p. 117, and Mancosu and Arana [2010], p. 404. These objections may not have been unknown to early modern geometers themselves. Proclus, in his Commentary to the the First Book of the Elements of Euclid, reports the following opinion, attributed to Geminus: "Geminus has rightly declared that, although a simple line can be produced by a plurality of motions, not every such line is mixed (...) Imagine a square unfergoing two motions of equal velocity, one lenghtwise and the other sidewise; a diagonal motion in a straight line will result" (Proclus [1992], p. 86). Hence, in Geminus' opinions, even lines we would accept as geometrical can be generated by a plurality of (independent) motions. The puzzle is solved by Proclus (supposedly reporting Geminus' view) by remarking that these motions are rectilinear and simple, contrarily to the motions which produce a linear curve like the helix (see ch. 2, sec. 2.3.4). However Proclus' explanation, which is not fully convincing (also the motions which generate mechanical curves, in fact, result from simple, circular and rectilinear motions) might not have been accepted by later readers.

⁷⁷See Mancosu [1999], p. 77-79, and Mancosu [2007], p. 117-122.

⁷⁸Descartes [1897-1913], vol. 6, p. 412.

with more care. I therefore observe, again with Mancosu (Mancosu [2007], p. 119), that Descartes assumed, in *La Géométrie*, two distinct and equally crucial assertions:

- A. The proportion between straight and curved lines is not known (exactly).
- B. The proportion between straight and curved lines cannot be known (exactly).

Assertion A. reports a piece of knowledge shared by the author and his audience: since, at the time of Descartes' writing no general methods were known and available to early modern geometers in order to solve rectification problems, the proportion between straight and curved lines was not known. Assertion B., instead, reports an utterance, in the form of a propositional attitude report (stressed by the verb "je crois") relating the opinion of the author himself on the unknowability of the proportion between straight and curved lines.

Descartes could infer, on the ground of B., that the proportion between segments and circular arcs could not be exactly known. Hence he could also infer a belief on the impossibility of rectifying the circumference, and thus solving the quadrature of the circle geometrically. This conviction, Mancosu argues, especially in Mancosu [1999] and Mancosu [2007], and not the general belief on the non-rectifiability of curves, could have played an essential role in separating geometrical from mechanical curves in the economy of Descartes' geometry. Indeed, Descartes might have been guided by the following inference, in order to demarcate legitimate from illegitimate curves: if a curve, together with other geometrical curves and constructions, allowed one to solve the quadrature of the circle, then it would be illegitimate in geometry, since the quadrature of the circle is judged by Descartes geometrically impossible. Eventually, the impossibility of solving the circle-squaring problem geometrically, asserted by Descartes on several occasions, both in *La Géométrie* and in his correspondence,⁷⁹ would have endowed him with a sufficient condition in order to exclude from geometry certain curves, like the quadratrix, the helix and, as it was known from Pappus and Archimedes, also the archimedean spiral, on the ground of their effects.⁸⁰

⁷⁹See, for instance, Descartes [1897-1913], vol. 1, p. 70-71; p. 486.

⁸⁰As pointed out in (Mancosu [2007], p. 118), this criterion is local, in so far it does not exclude from geometry all curves that one wants to consider mechanical. An example of a curve that was probably considered mechanical by Descartes, without satisfying this local criterion, is the *linea proportionum*, discussed in the *Cogitationes* (Descartes [1897-1913], vol 10, p. 222-223). Descartes introduced this curve in order to solve problems of compound interest, ie. problems concerning the computation of a debt increasing according to a geometrical rate in equal intervals of time. If we depict the problem geometrically, the *linea proportionum* would relate segments forming an arithmetical sequence (their

Mancosu's thesis is mathematically sound and based on textual evidence.⁸¹ However, I would like to supplement it with another hypothesis, which might contribute to shed more light on Descartes' self-confidence in delineating the boundary between geometrical and mechanical curves.

In order to deploy my argument, I shall recall that the specification of a curve by genesis has a bearing on the specification of its essential properties. In other words, Descartes conceded that all the points on a curve constructed by a geometric linkage, and "which we may call Geometric (...) must bear a definite relation to all the points on a straight line, and that this relation must be expressed by means of a single equation".⁸² As an equation codes a proportion or a system of proportions, we also recognize that an explicit connection is established, in Descartes' geometry, between a geometric curve, namely a curve constructed by one of the acceptable linkages, and the possibility of expressing its symptoms by means of an algebraic equation (chapter 3, section 3.2.3).

Let us consider, on the other hand, the original passage of *La Géométrie* in which Descartes contrasts geometrical and mechanical curves. So far, I have focussed my attention on the kynematical characterization of mechanical curves *qua* curves generated out of independent uniform motions, leaving aside another detail emphasized by Descartes: these motions do not entertain an exactly measurable relation namely: "aucun rapport qu'on puisse mesurer exactement".⁸³

constant difference represents the unit interval of time. If the unit interval is t , then the sequence will be: $t, 2t, 3t, 4t, \dots, nt$) to corresponding segments forming a geometrical sequence with constant ratio (if the ratio is r , the sequence will be: $1, r^1, r^2, r^3, \dots, r^n$), indicating the increase of the interest. The curve thus obtained is an exponential or logarithmic curve. The name "linea proportionum" bears a relation to the fact that the curve can be employed to find n -th mean proportions between two given segments. If we represent the segments $t, 2t, 3t, 4t, \dots, nt$ forming an arithmetical sequence, on a straight line, and the segments increasing according a geometrical sequence on another line perpendicular to the first, it would be sufficient to consider the segment of length $(n+1)t$: all the segments corresponding to $t, 2t, 3t \dots nt$ on the geometrical sequence will form the n mean proportionals between the initial segment of the geometric progression and the segment corresponding to $(n+1)t$. Interestingly, Descartes considered, in the *Cogitationes*, this curve on a par with the quadratrix, since the latter raises from two non subordinate motions, a circular and a rectilinear one (Descartes [1897-1913], vol 10, p. 223). The same cannot be told about the former, though. Even Descartes remains silent on this point, he probably conceived the "linea proportionum" as a line of the same nature of the quadratrix because it arose out of the combination of a uniform motion and an accelerated motion, whose velocities varies proportionally to the corresponding equal interval of time (Bos [2001], p. 248). This curve was probably judged by Descartes on a par with the quadratrix because it was difficult to envisage a geometric compass suitable for its generation. Although the *linea proportionum* is not discussed on other occasions, we can arguably assume that Descartes envisaged it as a mechanical curve, in the light of the partition proposed in *La Géométrie*.

⁸¹ Cf. Mancosu [1999], p. 78-79.

⁸² Descartes [1952], p. 48.

⁸³ Descartes [1897-1913], vol. 6, p. 390. For a discussion of this passage, see Bos [2001], p. 341-342.

Descartes also denies, as I have already reported, the possibility of knowing with exactness what he calls "proportion" between a curve and a straight line ("la proportion qui est entre les droites et les courbes"). Such a belief has been interpreted as the source of Descartes' conviction that it is impossible to measure with exactness the relation (*rapport*) between the rotational and translational motions in the genesis of the quadratrix and of the spiral.⁸⁴ But what did Descartes refer to when he spoke about such a "rapport" between the motions which generate mechanical curves, that we cannot measure exactly?

I remark that the word "rapport" reappears, in *La Géométrie*, few pages later, in order to designate the opposite situation of geometrical curves:

... tous les points, de celles qu'on peut nommer Geometriques, c'est a dire qui tombent sous quelque mesure précise et exacte, ont necessairement quelque *rapport* a tous les points d'une ligne droite, qui peut estre exprimé par quelque equation, et tous par une mesme.⁸⁵

And again few lines later, while studying the hyperbola, Descartes set out to find the *rapport* between the unknowns x and y which characterize every point of the hyperbola. Indeed any point that we may arbitrarily choose on the curve traced by the linkage described by Descartes (I am referring to Descartes [1897-1913], vol. 6, p. 395) is such that its distances from axes GA and AK entertain the same relation, coded by the equation: $ay + cy - \frac{cx}{b}y - y^2 = ac$.⁸⁶

In these cases, the word "rapport" refers to the relation that a point on a curve, constructible by a geometric linkage, entertains with the points on given straight lines: in other words, 'rapport' refers here to a proportion or an equation which characterizes the curve itself.

If we assume that Descartes employed his lexicon univocally, we might also refer the term 'rapport', appearing in the description of mechanical curves, to the relation between the

⁸⁴Bos [2001], p. 341ff.

⁸⁵Descartes [1897-1913], vol. 6, p. . The emphasis is mine.

⁸⁶I share here the suggestion made by (Descartes [2009], p. 716): "le mot rapport ne signifie pas ici *proportion*, ou *raison*, mais *relation numérique*; et bien qu'il soit question d'une seule ligne droite (un axe de coordonnées), et non de deux, il s'agit bien d'une equation avec deux variables x et y ". See also Molland: "Descartes's interpretation of what was meant by an exact knowledge of the measure of a curve may have undergone some development, but in the Geometric he clearly explicates it in terms of equations" (Molland [1976], p. 37).

distances of any point on the curve from given straight lines (or axes of references, in a modern parlance), and therefore to the possibility of coding the fundamental properties of such curves as the quadratrix and the spiral into an algebraic equation.

Descartes was certainly aware that in ancient geometrical thinking, the articulation between the exhibition of a curve through its construction and the subsequent determination of its fundamental properties concerned the study of curves even beyond conic sections. The same opinion can be gathered from a short but informative remark made by Proclus:

This is the way in which other mathematicians also are accustomed to distinguish lines, giving the property of each species. Apollonius, for instance, shows for each of his conic lines what its property is, and Nicomedes likewise for the conchoids, Hippias for the quadratrices, and Perseus for the spiric curves. After a species has been constructed, the apprehension of its inherent and intrinsic property differentiates the thing constructed from all others.⁸⁷

It cannot be overlooked that the quadratrix is mentioned in the previous passage. Its symptoms, together with those of the spiral, are described by Pappus, another source well known to Descartes, in these terms, for the quadratrix:

And its principal symptoma is of the following sort. Whichever arbitrary <straight line> is drawn through in the interior toward the arc, such as AZE , the straight line BA will be to the <straight line> ZT as the whole arc < \widehat{BED} is> to the arc \widehat{ED} .⁸⁸

Whereas for the case of the spiral:

Its principal symptoma is of the following sort. Whichever <straight line> is drawn through the interior toward it, such as BZ , and produced <to C >, the straight line AB is to the <straight line> BZ as the whole circumference of the circle is to the arc \widehat{ADC} . This, however, is rather easy to understand from the genesis <of the spiral>. For in the time in which the point A passes through the whole circumference of the circle, in that time the <point starting> from B <passes through> BA , also, whereas in the time in which A <passes through> the arc \widehat{ADC} , in that time the <point starting> from B <passes through> the straight line BZ , also.⁸⁹

⁸⁷Proclus [1992], p. 277.

⁸⁸Proclus [1992], p. 277.

⁸⁹Proclus [1992], p. 277.

In his commentary, Commandinus also adds an important note about the cylindrical helix:

... cuius principale accidens est, ut sumpto quovis puncto in ipsa, quod exempli gratia sit H , ductaque HD ad planum perpendiculari, habeat HD ad circumferentiam DC eam proportionem, quam tota CM habet ad circumferentiam DCA . illud vero ita esse ex ipso ortu manifestum apparet.⁹⁰

The fundamental properties of the mechanical curves known to Descartes can be thus schematized (*cf.* ch. 2, sec. 2.3.2 and sec. 2.3.3). In the case of the quadratrix, they are expressed by the proportion: $BA : ZT = \widehat{BED} : \widehat{ED}$, (keeping the same letters as in Pappus' passages quoted above), whereas for the spiral the analogous proportion is: $BA : BZ = circ : \widehat{ADC}$, where 'circ' denotes the circumference mentioned in the above passage. Finally, Commandinus' commentary reports the symptom ("accidens") of the cylindrical helix too: if we call HD and CM the two perpendiculars to the base of the cylinder from points H and M , both on the helix, \widehat{DC} the arc cut on the base by the foets of these perpendiculars, and \widehat{DCA} the length of the circular base, we have that: $HD : \widehat{DC} = CM : \widehat{DCA}$.

As a reader of Pappus *apud* Commandinus, Descartes was certainly aware that the symptoms of curves like the quadratrix, the spiral and similar curves involve a proportion between segments and arcs of a circle, derivable from the uniform motions generating these curves. Counter to the case of conic sections and of the other geometric curves, whose symptoms can be expressed by proportions between segments (and ultimately via equations), the symptoms of the quadratrix, the spiral or the cylindrical helix, as they are expounded in Pappus' *Collection*, cannot be expressed in such a form, since Descartes had assumed that the proportion between circular arcs and a straight lines (and more generally, between straight and curves) defied exact knowledge.

Let us recall, moreover, that Descartes admitted the equivalence between curves constructible by linkages, and curves expressible by algebraic equations (chapter 3, section 3.2.3). On this ground, he could immediately infer from the impossibility of expressing the properties of a curve by an algebraic equation, the impossibility of constructing

⁹⁰Commandinus [1588], 58v.: "Whose [i.e. of the cylindrical helix] fundamental property is that, taken any point in it, which for instance is H , ad traced HD , perpendicular to the base, HD has to the arc DC the same proportion, that all CM has to the circumference DCA . But in fact it appears that this is evident from the very genesis."

the curve by a geometric linkage. This conclusion complies with the characterization of mechanical curves as curves constructible solely by separated motions.

Conclusively, the impossibility of representing the fundamental properties of a curve by a system of proportions, and therefore by means of the apparatus offered by algebra, could represent a further reason in order to explain Descartes' self-confidence in excluding certain curves as mechanical, although it remains a sufficient, not a necessary criterion of ungeometricality, just like the criterion studied in Mancosu [1999] and Mancosu [2007], to which it is evidently related: both criteria are in fact ultimately grounded on the incomparability between straight and curvilinear lines.

Certainly, there are curves non expressible by algebraic equations, but whose symptoms do not depend on the proportion between segments and arcs (Mancosu [2007], p. 122). The case of the *linea proportionum*, already mentioned in this dissertation, is an eloquent counterexample with this respect.⁹¹ But we can still maintain that the appeal to the impossibility of finding an exact proportion between straight lines and circular arcs offered a sound justification, when Descartes was preparing *La Géométrie*, in order to exclude from geometry those few special curves, like the spiral, the quadratrix and the cylindrical helix, transmitted by ancient sources, and mostly studied by early modern practitioners.

On this connection, I surmise, Descartes showed, by underlying the inexact character of the pointwise constructions and the constructions by strings of the quadratrix the spiral, and the helix, that all the attempts to exhibit the geometrical nature of these curves (as we have seen, several geometers were engaged in this 'research programme', between late '500 and the following century) had globally failed. Moreover, by excluding such mechanical curves from geometry, perhaps on the ground of their symptoms, and therefore relying on classical considerations (let us recall that the symptoms of the mechanical curves are already described in Pappus' *Collection*) Descartes might want to assert, once

⁹¹See note 80. Descartes became acquainted, after the publication of *La Géométrie*, with other curves like De Beaune's curve (which is a logarithmic curve), or the logarithmic spiral, both explicitly recognized as mechanical, although not in the backdrop of the incomparability between straight and curvilinear segments. For a detailed investigation about Descartes' study of this curve, see Vuillemin [1987], p. 1-25. Descartes judged De Beaune's curve mechanical, on the ground of its generation by two movements: "tellement incommensurables, qu'ils ne peuvent estre réglé exactement l'un par l'autre; et ainsi que cette ligne est du nombre de celles que j'ai rejeitées de ma Geometrie, comme étant Mechanique", Descartes [1897-1913], vol. 2, p. 517. The logarithmic spiral was introduced by Mersenne in his *Harmonie Universelle*, and was the curve represented by a body descending on an equally inclined plane (Descartes [1897-1913], vol. 2, p. 360).

established a clear-cut canon of geometricity, that any investigation aiming at probing the geometrical nature of the quadratrix, the spiral or the helix, was destined to fail.⁹² Such a methodological choice did not imply that mechanical curves had to be abandoned as objects of mathematical interest. Let us recall, indeed, as it has been amply studied in the literature,⁹³ that Descartes dealt with mechanical curves outside geometry.

Conclusively, I would like to stress that the possibility (resp. impossibility) of expressing their symptoms of curves via equations eventually became the usual way of shaping the bounds between geometrical and mechanical, or transcendental curves, when Descartes' method in problem solving became one of the staple of eighteenth century mathematical textbooks.⁹⁴

As an evidence for this claim, I will offer two examples, both taken from expository treatises written during the first half of XVIIIth century. The first example is taken from Guisnée's treatise *Applications de l'algebre a la Geometrie, ou Methode de demonstrier par l'Algebre, les Theorèmes de Geometrie, et d'en resoudre et construire tous les Problèmes* (1733). The last section of this book is dedicated to "mechanical or transcendental curves, their descriptions and the problems one can solve by them". In this chapter of Guisnée's book, mechanical curves are not primarily introduced by a specification of their genesis, as it happens in Descartes' *Géométrie*. On the contrary, Guisnée characterizes them as those curves for which:

... on ne peut point trouver d'équations qui expriment geometriquement la relation de leurs coordonnees; car il y a des courbes mechaniques dont une des coordonnees est une ligne droite, et l'autre une ligne courbe dont la rectification est geometriquement impossible. Il y en a d'autres dont les deux coordonnées sont deux lignes courbes; d'autres dont les appliquées partent toutes d'un même point, et d'autres qui sont figurées de manière que leurs axes les rencontrent en une infinité de points ...⁹⁵

At the root of the distinction between curves whose coordinates can be "expressed geometrically" and curves whose coordinates cannot undergo the same treatment, we can

⁹²The possibility that Descartes was addressing to the practice of curve-construction, still lively in the 1630s is also ventured in Giusti [1999], p. 232.

⁹³For instance: Costabel [1985], Mahoney [1984], Jullien [1996], Jullien [2006], Vuillemin [1987].

⁹⁴An overview of XVIIIth century expository treatises on cartesian geometry can be found in Shabel [2003], p. 70ff.

⁹⁵Guisnée [1733], p. 233.

still find the cartesian characterization of geometrical curves, as those curves such that the distances of any of their points from one given straight line (the first occurrence of what would later be called axis of coordinates) can be expressed by means of a finite algebraic equations. On the other hand, a point on a mechanical curve like the spiral (discussed by Guisnée in the same text few lines later) can be individuated by expressing a proportion combining segments and circular arcs, whose rectification, Guisnée observes above, is held to be "geometrically impossible".

As it was already known to Descartes, not all mechanical curves could be associated to proportions involving segments and circular arcs. The local character of this criterion would become even clearer during XVIIth century and XVIIIth century, when the number of mechanical curves grew considerably, and only a small part turn out to depend on the rectification of arcs. This fact is underlined by Guisnée too, who gives, in the passage we can read above, a brief survey of several types of mechanical curves, each being characterized by a specific property of their coordinates. On the other hand, all these curves have in common the (negative) property of not being relatable to finite algebraic equations.

Along similar lines, Ozanam defines mechanical curves, in his *Dictionnaire des mathématiques* (1696), without reference to the motions which generate them:

La ligne mécanique est une ligne courbe qui n'a point d'Equation propre a exprimer la Relation de tous ses points sur quelque ligne droite. Telle est la *Quadratrice* de *Dinostrate*, et plusieurs autres...⁹⁶

A final significant example is reported by Rabuel, who wrote an extensive commentary on Descartes' geometry, and noted:

Les courbes Géométriques sont celles, dont on peut exprimer et déterminer la nature par le rapport des ordonnées et des abscisses, qui sont les unes et les autres des grandeurs finies. Les Mécaniques sont celles, dont on ne peut ainsi exprimer la Nature, parceque les ordonnées et les abscisses n'ont point de rapport réglé.⁹⁷

Examples might be multiplied, among contemporary treatises on cartesian geometry. This brief survey is however sufficient in order to show that the bound between geometrical and mechanical curves ended up being currently understood and formulated,

⁹⁶Ozanam [1691], p. 94.

⁹⁷Rabuel [1730], p. 99.

from late XVIIth to the beginning of XVIIIth century, as a bound between curves expressible by a finite algebraic equation, and curves which could not be expressed by a finite algebraic equations, thus exploiting a suggestion that, I think, was originally in *La Géométrie*.⁹⁸

⁹⁸On the history of analytic geometry, especially after the publication of *La Géométrie*, see Boyer [1956].

Chapter 6

Impossible problems in cartesian geometry

6.1 On the cartesian distinction between possible and impossible problems

According to my reconstruction, the impossibility of finding an exact proportion between segments and arcs of circles offers a rationale in order to understand the clear-cut separation, in Descartes' geometry, between geometrical and mechanical curves. In particular, the latter curves are not generated according to a legitimate procedure, and their 'symptoms', or fundamental properties, cannot be characterized by a quantifiable relation expressible through a proportion between segment, or through an algebraic equation.

In Descartes' *Géométrie*, though, the claim that segments and circular arcs are incommensurable magnitudes or, at least, magnitudes that stay to each other in an exactly unknowable proportion, does not rely on any proof or argument. Probably on this ground, Bos referred to it (or, more precisely, to its possible generalization) as: "the axiom of incommensurability of the straight and the curved", and traced the axiom back to an aristotelian view on the nature of curves, still influential in the first half of seventeenth century.¹

Can we find any trace, in Descartes' mathematical activity, of attempts to justify this so-called "axiom"? This is the question I have in view in this and the following sections.

¹See Bos [1981], p. 314; Bos [2001], p. 342; Hofmann [2008], p. 101-103.

As a start, I remark that Descartes occasionally discussed, during his mathematical career, the problem of the quadrature of the circle. These discussions might, in principle, be pertinent to our inquiry, since, as Archimedes's *Dimensio circuli* does show, the circle-squaring problem is reducible to the rectification of the circumference. We expect therefore, coherently with Descartes' view about incomparability between straight and curves, that Descartes judged this problem unsolvable in geometry.

On the other hand, Descartes rarely entered into considerations which might offer arguments for the possibility/impossibility of solving the circle-squaring problem by given solving-methods.²

An interesting exception can be found in a letter to Mersenne from 31 March 1638. In a section of this long letter, Descartes comments upon some objections raised by contemporary geometers, in particular Fermat and Roberval, concerning those: "... questions de Geometrie qu'ils ne peuvent soudre et croient ne pouvoir estre resolues par ma methode..." (Descartes [1897-1913], vol. 2, p. 90).

In his response, Descartes did not deal with the specific content of these objections, but proposed a methodological discussion about problems that could or should be proposed as legitimate ways in order to challenge the method proposed in *La Géométrie*:

... car premierement, c'est contre le style des geometres de proposer aux autres des questions qu'ils ne peuvent soudre eux mesmes. Puis il y en a d'impossibles, comme la quadrature du cercle, etc. ; il y en a d'autres qui, bien qu'elles soient possibles, vont toutefois au dela des colonnes que j'ai posees, non a cause qu'il faut d'autres regles ou plus d'esprit, mais a cause qu'il y faut plus de travail. Et de ce genre sont celles dont j'ay parlé dans ma réponse à M. de Fermat sur son escrit *de maximis et minimis*, pour l'avertir que, s'il vouloit aller plus loin que moy, c'estoit par la qu'il devoit passer. Enfin il y en a qui appartiennent a l'Arithmetique et non a la Geometrie, comme celles de Diophante ...³

²Few remarks can be found in Descartes's correspondence, which relate his scornful opinion with respect to alleged solutions to the quadrature of the circle. The first documented situation which saw Descartes's involvement with the squaring of the circle was brought about by a letter from Van Schooten (10th March 1649), Descartes [1897-1913], vol. 5, p. 318-320. On that occasion, Descartes criticized the work of Gregorius of St. Vincent. See also Descartes [1897-1913], vol. 5, p. 343, where Descartes dismisses a flawed solution to the quadrature of the circle by Longomontanus.

³Descartes [1897-1913], vol. 2, p. 90-91.

In the passage quoted above, Descartes mentions the quadrature of the circle as an "impossible problems", and contrasts it with arithmetical problems, on one hand, and on the other, with "possible problems" which, though solvable in principle, still demand an effort ("travail") for their solution.

Correspondence and correspondence networks played indeed a major role, within the community of early-modern mathematicians, for the circulation of theories and methods. Problems often laid at the core of these exchanges: they were in fact proposed in order to challenge a given method, to test its generality or the ability of his proponent in front of difficult cases, and eventually enhance or downplay his rank in the community of mathematicians.⁴

In this general context, Descartes was concerned with the overriding task of regulating the ways in which his method could be legitimately challenged. In the backdrop of this attitude, I propose to interpret the above distinction into different types of problems as an explicit attempt, on Descartes's side, to set norms in order to tailor the development of geometry, and the correlative practice of problem-solving according to the method and the rules set in *La Géométrie*.

At first, it should be noted that Descartes disqualifies as contrary to the style of geometers proposing problems that "they cannot solve themselves. . ." ("questions qu'ils ne peuvent soudre eux memes"). This remark does not aim so much at isolating a category of problems, but rather at deterring geometers from proposing "open" problems, namely problems not only in want of a solution (which is an obvious requirement if a method must be challenged at all), but for which it is not known whether a solution can be found at all, in order to challenge a certain method (and, in the specific context of the letter, his own method).⁵

⁴Compare on this subject the recent studies Goldstein [2009] and Goldstein [2013].

⁵Such a distrust towards open problems is by no means original with Descartes. As an example, let us recall that Fermat did pose open questions, to the effect that his recipients were displeased by this attitude, fearing that behind these questions impossible problems might lurk (Fermat [1891-1896], vol. 2, p. 260-261). On the contrary, Fermat defended the importance of asking open problems and theorems. He was in fact confident of the significance for the development of mathematics; as we read in a letter to Mersenne from August 1643, he remarked: "... il y a beaucoup de problèmes desquels, comme a dit autrefois Archimède, οὐκ εὐμέθοδα τῶ πρώτῳ φανέντα χρόνῳ τήν ἐξεργασίαν λαμβάνονται". *Vid.* Heath [1897], p. 151: "In fact, how many theorems in geometry which had seemed at first impracticable are in time successfully worked out!" (Fermat's quote slightly modifies Archimedes's original, to be found in the treatise *On Spirals*).

Furthermore, Descartes evoked three categories of problems: problems from arithmetic, possible and impossible problems. I surmise that two distinct issues are at play in the backdrop of this tripartite distinction. One issue is of disciplinary nature (I borrow the term ‘disciplinary’ from Goldstein [2013]), since it concerns the distinction between arithmetic and geometry: arithmetical problems are in fact isolated and as extremely laborious, but useless, and therefore not worth of discussion and challenge.⁶

On the other hand, Descartes did not consider all problem concerning geometric entities as suitable cases in order to challenge his method. To this effect, I note that, whereas *La Géométrie* contains explicit criteria for separating acceptable from non-acceptable curves, thus demarcating the ontology of Descartes’ geometry, there are no further distinctions, in this treatise, between acceptable and non-acceptable problems, in analogy with the distinction between permissible, or geometrical, and non permissible, or mechanical curves.

This silence might be explained on the ground of the practice, current among early-modern mathematicians and practitioners, to delegate to epistolary exchanges the task of challenging a method for problem-solving. Correlatively, defining the kind of admissible questions (i.e. problems) would have been considered as an activity (that we might label as ‘meta-theoretical’, since it concerns the setting of rules in order to shape mathematical activity itself) to be more properly performed in correspondence than in a treatise.

⁶Descartes remarks: "... non pas pour ces dernieres [arithmetical questions] qu’elles soient plus difficiles que celles de Geometrie; mais pource qu’elles peuvent quelquefois mieux estre trouvées par un homme laborieux qui examinera opiniastrement la suite des nombres, que par l’adresse du plus grand esprit qui puisse estre, et que d’ailleurs elles sont tres inutiles, je fais profession de ne vouloir pas m’y amuser" (Descartes [1897-1913], vol. 2, p. 91). I point out that by "problems of arithmetic" Descartes probably meant questions concerning the theory of numbers, whose main proponent was, by that time, Pierre de Fermat. Descartes’s disparaging attitude is similar in outlook to the opinions of other geometers who looked favourably to the "new" analysis exemplified by the canon of problem-solving promoted in *La Géométrie*, as De Beaune: "Je vous supplie de me dispenser de la recherche de ceste question - he wrote to Mersenne on March 1639, concerning a problem of arithmetic - pour m’appliquer, aus heures de mon loisir, à de plus sérieuses : ceste question n’estant d’aucun usage et ne tombant point sous la science des rapports, qui les considere universelement aussi bien entre les lignes commensurables et incommensurables si bien que la recherche en seroit extremement laborieuse et de nul proffict, ce qui n’arrive pas en celles de geometrie et celles d’arithmétique qui tombent sous la science des proportions, les autres estant de peu de consideration et n’estant d’aucun usage" (Mersenne [1986], vol. VIII, p. 360). The problem De Beaune wanted to avoid concerned the determination of a class of numbers that are sums of squares: it was therefore a problem concerning integer numbers, at its core, although it was presented in a geometric garb, as a problem about ellipses (Goldstein [2013], p. 266). Even without entering the details of the problem, its presentation is sufficient to show that the distinction between geometrical and arithmetical problems was not so obvious as it may seem.

Indeed, this delimitation is arguably implied by the second distinction, articulated by Descartes in the above letter to Mersenne, between ‘possible’ and ‘impossible’ problems. As we can evince from the general description and from the examples evoked in that letter, ‘possible’ problems are problems which, though solvable in principle, still demand "more effort" ("*plus de travail*") for their solution. Among them, Descartes counts those problems discussed in another letter written to Mersenne, in January 1638.⁷

That letter contains a lengthy response on Fermat’s method for finding the tangent to a given algebraic curve (for example, a parabola).⁸ Descartes refuses to consider Fermat’s achievement as a legitimate challenge to his geometry, and encourages, on the other hand, geometers to turn towards other challenges: to solve the general problems of the composition of the sursolid loci (namely, the problems yielding indeterminate equations in degree 6 or 5) or the construction of all problems of degree 6 or 9, or, eventually, the construction of burning mirrors composed of a sphere and a conoid in order to test their knowledge and understanding of the cartesian method.⁹

These examples clarify that the ‘possible problems’ mentioned in the 1638 letter are, in Descartes’ view, problems for which a solution is envisionable within the canon of his geometry, because they can be reduced to an equation or a system of equations expressing the dependance between segments designated by the unknown(s) and the known terms, according to the protocol expounded at the beginning of *La Géométrie*.

In the backdrop of this characterization of ‘possible problems’, I surmise that ‘impossible’ ones, exemplified by the quadrature of the circle, are purportedly excluded from the scope of *La Géométrie* because they are not problems in the sense countenanced by the opening paragraph of this treatise, namely they are not reducible to equations expressing

⁷Descartes [1897-1913], vol. 1, p. 486.

⁸Here the quotation from Descartes’ letter: "De façon que ceux qui ont envie de faire paroistre qu’il savent autant de Geometrie que j’en ay escrit, ne doivent pas se contenter de chercher ce Probleme par d’autres moyens que j’en ai fait, mais ils devraient s’exercer plutost a composer tous les lieux sursolides, ainsy que j’ai produit tous les solides, et à expliquer la figure des verres brulants, lorsque l’une de ces superficies est une partie de Sphere ou de Conoïde donné", Descartes [1897-1913], vol. 1, p. 492-93. The peculiarity of Fermat’s method (see Stromholm [1969], for a reconstruction) lies in the idea of identifying the tangent to a curve as its secant of maximal length. Descartes dissented about this conception, preferring, in order to solve the problem of tracing a tangent to a given algebraic curve, to develop a method of normals, but he shared the view according to which the general problem of tracing the tangent to a curve (or, in his perspective, tracing a normal) can be considered as a specific example of a problem of *extremum*.

⁹I remark that an example of problem neither plane nor solid is discussed in Descartes [1897-1913], vol. 2, p. 317.

the relations between known and unknown segments, and are obviously unfit in order to test the canon of problem-solving set out in *La Géométrie*.

This conclusion not only confirm Descartes' conviction that the circumference cannot be rectified geometrically. The case of the quadrature of the circle is also telling for another reason. Probably around 1625-1628, in fact, Descartes wrote a brief text which purports to give the best way to solve this problem by means of an approximation argument based on iterated bisections, akin to Archimedes's method for approximating the length of the circumference.¹⁰ Descartes solved the circle-squaring problem by giving a rule in order to produce, through an interactive ruler-and-compass construction, a sequence of points converging towards a limit-point x . This point is determined through an infinite approximation procedure, hence it is by no means 'constructed', according to the meaning of this word in force within Descartes' geometry: in other words, point x is not found by the intersection between geometric curves.

The fragment on the circle-squaring problem is not only an interesting mathematical achievement *per se*, but it indirectly elucidates the meaning of 'impossible' problems, according to Descartes' use made in the letter to Mersenne. It should be noted, indeed, that the cartesian solution of the quadrature of the circle relied on a practice which made

¹⁰See Descartes [1701], p. 6-7, and Descartes [1897-1913], vol. 10, p. 304-305. This piece was published only posthumously, in the *Excerpta ex Mss R. Des-Cartes* (1701), so that the precise occasion which inspired its composition is unknown. The brief text can be reported here in full: "CIRCULI QUADRATIO. Ad quadrandum circulum nihil aptius invenio quam si dato quadrato bf adiungatur rectangulum cg comprehensum sub lineis ac et cb , quod sit aequale quartae parti precedentis; item rectangulum dh , factum ex lineis da , dc aequale quartae parti precedentis; et eodem modo rectangulum ei , atque alia infinita usque ad x ; quae omnia simul aequantur tertiae parti quadrati bf . Et haec linea ax erit diameter circuli, cujus circumferentia aequalis est circumferentiae huius quadrati bf , est autem ac diameter circuli octagono, quadrato bf isoperimetro, inscripti; ad diameter circuli inscripti figurae 16 laterum, ae diameter circuli inscripti figurae 32 laterum, quadrato bf isoperimetrae, et sic in infinitum" ("To square the circle, I find nothing more adequate than that, being given a square bf , to add the rectangle cg delimited by lines ac and cb , equal to the fourth of the preceding figure, and then to add the rectangle dh , formed by the segments da , dc , equal to the fourth of the previous one, and in the same way to add rectangle ei , and other ones, infinitely, until point x is reached. All together, they will make one third of the square bf . On the other side, ac is the diameter of the circle inscribed into the octagone isoperimeter to the square bf , ad the diameter inscribed in the figure of 16 sides, ae the diameter of the circle inscribed in the figure of 32 sides, isoperimeter to the square bf ... and so on infinitely."). The title *Circuli quadratio* was added in Adama-Tannery critical edition, on the basis of an index excerptorum that accompanied Descartes's mathematical fragments collected in Descartes [1701]. The authenticity of this fragment can be hardly put into doubt. The text was indeed known to Huygens, at least since 1654, as it is quoted in the introduction to his *De Circuli Magnitudine Inventa* of the same year. Descartes was himself an acquaintance of Huygens's family, and Christiaan Huygens himself acknowledged, only four years after Descartes's death, that Descartes had written some pieces on the quadrature of the circle (*Vid.* Huygens [1888-1950], vol. 12, p. 119-120). As for a mathematical analysis of the content of this fragment, see Costabel [1985].

appeal to different constraints on solvability and unsolvability of problems than those in force in *La Géométrie*. Hence, the ‘impossibility’ of solving a problem, at least in the context of the 1638 letter, did not entail, for Descartes, its unsolvability *tout court*, but its unsolvability by means of the techniques and the method deployed within cartesian geometry.

On a par with the quadrature of the circle, we recognize other problems, studied and solved by Descartes in his correspondence, that might be ascribed to the same category of "impossible problems". These are, for instance, problems concerning the construction or the properties of objects explicitly recognized as non geometrical, like mechanical curves. Remarkable examples are the problem of determining the tangent to a point on the cycloid, a mechanical curve according to Descartes, discussed by Descartes in a letter to Mersenne from 23rd August 1638 (in Descartes [1897-1913], vol.2, p. 307ff.), the problem of determining the area under a cycloidal arc, discussed by Descartes with Mersenne, in two letters, from May 1638 and July 1638 (see Descartes [1897-1913], vol.2, pp. 135-137 and 257ff.) or the problem of describing the equiangular spiral, defined as the (mechanical) curve making a constant angle with the radius vector at every point (see Descartes [1897-1913], vol.2, p. 360).

I surmise that, consistently with the characterization of "impossible" problems that I have tried to elucidate in this section, all the problems evoked above can fall into this category because, even if they could not be counted within the subject matter of geometry, they could nevertheless be solved by appeal to diverse techniques, well-mastered by Descartes.¹¹

6.2 Impossibility claims as a meta-statements

Even if the meaning of ‘impossible problem’ can be clarified in the light of Descartes’ methodological considerations about problems, yet two questions remain to be answered: on which grounds the quadrature of the circle could be judged impossible? Could the task of proving such an impossibility be considered a legitimate task at all in the mathematical practice of XVIIth century?

Firstly, I point out that even if the impossibility of constructing a certain geometric entity might be posed as a problem in disguise, proving an impossibility boils down to

¹¹Compare, on this concern, the technical analysis in Costabel [1985] and Jullien [1999].

proving a theorem. But the activity of theorem-proving occupied a peripheral role in the network of exchanges between mathematicians Descartes was part of.¹²

Moreover, proving impossible theorems was an activity generally met with disregard by mathematicians of XVIIth century.¹³ One reason can be found in the nature of such propositions: impossible theorems departed from the current view, still inspired by the standard definition found in Proclus' *Commentary*, according to which a theorem establishes a property of a given or constructed figure.¹⁴

A further reason that might have deterred Descartes from attempting to prove the impossibility of squaring the circle geometrically concerns the very structure of impossibility arguments. Even if no one had produced, by the half of XVIIth century, a proof that the circle-squaring problem could not be constructed in a geometrical way, it was envisionable that such a proof ought to rely on a *reductio* argumentation.

Descartes expressed an unmitigated judgement concerning proofs involving indirect arguments, for instance in his critique to the method of Fermat (in Descartes [1897-1913], vol. 1, p. 489-490) which relied on indirect proofs, namely: "... la façon de démonstrer qui réduit à l'impossible (...) la moins estimée et la moins ingénieuse de toutes celles dont on se sert en Mathématique". This criticism was by no means the expression of a personal belief, as it was shared by a large audience and motivated on the ground of a precise philosophical position, as the analysis in Mancosu [1999] has amply illustrated. Arnauld and Nicole, for instance, evoke demonstrations by impossibility as a "defect" in geometry: "demonstrations by impossibility ... while they may convince the mind, they do not enlighten it, which ought to be the chief result of knowledge; for our mind is not

¹²Cf. Goldstein [2013], p. 258-259: "Theorems when mentioned are facts to be used, eventually to be commented, more than results of a necessary demonstrative procedure".

¹³Significant is the example of Fermat who, since the beginning of his mathematical career (cf. Goldstein [2013], p. 270), proposed impossible problems in arithmetic, which failed to raise the interest of his recipients. Moreover the 'bad habit' of proposing impossible problems caused some epistolary relations to cease (Fermat [1891-1896], vol. 2, p. 260) or could raise the irritation of mathematicians (noteworthy is Wallis' reaction, in Fermat [1891-1896], vol. 3, p. 468; cf. Lützen [2010], p. 8).

¹⁴Cf. Introduction of this study. If we consider a work that well represents XVIIth century practice, as the *Dictionnaire mathématique* (1691) by Jacques Ozanam, we can note that Proclus' conception of problems and theorems is fundamentally accepted: "le probleme - wrote Ozanam in the *Dictionnaire* - est une proposition qui tend à la pratique, comme de diviser une ligne terminée en autant de parties égales que l'on voudra ... " (Ozanam [1691], p. 2). On the other hand, Ozanam also agrees with Proclus' characterization of a theorem: "le theoreme est une proposition speculative, qui exprime les proprietés d'une chose. Comme quand on dit que dans un triangle rectiligne la somme des trois angles est égale à deux droits, et que dans un triangle spherique la somme des trois angles est plus grande que deux droits ... " (Ozanam [1691], p. 8).

satisfied until it knows not only that a thing is, but why it is, which cannot be learnt from a demonstration which reduces it to the impossible." (quoted in Mancosu [1999], p. 101).

These considerations suggest that Descartes might not consider the claim that 'the quadrature of the circle is impossible' on a par with usual geometric theorems. In other words, he did not deduce an impossibility from the supposition that the circle could be squared geometrically, as in a *reductio ad absurdum*, but inferred the impossibility of squaring the circle geometrically as a consequence from the 'axiom of incomparability of the straight and the curved'.

Although this axiom or, more precisely, its restriction to the case of segments and arcs of the circle, invested the very activity of problem-solving and contributed to shaping a meaningful separation between geometrical and ungeometrical curves, as I have argued in the previous chapter, it was not justified by Descartes, nor explained any further.

As suggested by Bos or by Hoffman,¹⁵ Descartes' belief on the impossibility of finding an exact proportion between a straight line and a curved line might be traced back to an ancient classification of lines, which echoes in Aristotle's *Physics*, and was later resumed by Averroes. In particular, straight lines and arcs of circles, on one hand, and polygons and circles, on the other, cannot be compared, since they ultimately belonged to different kinds (see ch. 1, sec. 1.4.1). It can be conjectured that Descartes was influenced by this aristotelian-averroistic view on curves at some stages of his career, although the details of such influence (by which mediator, and through which sources was he exposed to this view? and why did he accept it?) are at present unknown, and certainly worthwhile of further investigations in the future.¹⁶

¹⁵See Bos [1981], p. 314; Bos [2001], p. 342; Hofmann [2008], p. 101-103.

¹⁶Descartes was educated according to the 1599 *Ratio Studiorum*, a practical handbook in educational method and college management which established the influential system of jesuitic education. It is well known that the teaching of Aristotle had an extant role in that training, although it is dubious whether a specific teaching on the squaring of the circle were imparted too; on the contrary, the difficulty of the subject made it a topic for research mathematicians rather than for apprentices (See Romano [2000], especially on pp. 255-266, for details about the educational system in Jesuit schools). It is worth mentioning, with respect to the problem of the quadrature of the circle, the jesuit father Antoine Jordin (1562-1636), who was responsible, between 1604 and 1606, for the education of students in philosophy at Collège de la Madeleine, in Bordeaux. As it can be read in the manuscript of his courses, Jordin dedicated an entire section of his geometry class to a discussion of the problem of the squaring of the circle. Although expositions on the quadrature of the circle were by no means the rule, in the jesuitic elementary teaching, Jourdin's exception leaves the possibility open that Descartes might have been acquainted with the problem since his early formation. Among Jordin's sources, we can list Clavius'

Leaving aside the origins and plausibility of the Aristotelian standpoint, we can still inquire about the reason why Descartes did not feel bound to offer any justification for this belief. I surmise that the impossibility of expressing the proportion between segments and arcs of the circle in an exactly knowable way could have assumed the role of a ‘meta-statement’ with respect to Descartes’ geometry and to the canon of problem-solving established in it.¹⁷ If we suppose that Descartes adopted the non-comparability between straight and circular magnitudes as a sort of meta-statement guiding the practice of problem-solving (for instance, by ruling out certain problems from the ambit of those that the geometer should tackle), it is not obvious that such a meta-statement could or should be proved on a par with common theorems. Therefore, it is not surprising either that Descartes did not produce any mathematical justification for the claim that the proportion between straight and curves cannot be known exactly, nor it is astounding that he might have simply relied on a rather ‘metaphysical’ position, as Bos and Hoffman (among others) claim. In this, Descartes was continuing a custom that was proper of ancient mathematicians, or mathematicians of late antiquity, who took for granted the

Geometria Practica (published in 1604) and, more probably, the second edition of his commentaries on Euclid’s *Elements* (from 1589), since both works contained substantial digressions on the quadrature of the circle. It should be pointed out that Clavius was very influential at *La Flèche*, where Descartes took his first training in mathematics. Hence it can be supposed with some likeliness that Descartes knew of Clavius by 1615-16, the years in which he graduated from the school, although we cannot say with certainty that Descartes knew by this time Clavius’ remarks on the quadrature of the circle (See Sasaki [2003], p. 51). I note, in particular, that the passage from Aristotle Book VII of the *Physics*, concerning straight and curved lines, is critically evoked in Clavius’ commentary to the *Elements*, a text certainly perused by Descartes in later years. Clavius’ opinion about Aristotle’s axiom is negative, as we can read: "Hae etenim [namely, straight lines and curves] ita differre inter se videntur, ut Aristoteles liquido affirmarit, unam alteri aequalem esse non posse, quod tamen (pace Aristotelis dictum sit) verum usquequaque non est, cum Archimedes in lib. de lineis spiralibus demonstraverit, quatenam linea recta aequalis possit esse circumferentia cujusvis circuli dati, idemque in quadratura circuli ostenderimus", (Euclid [1589], p. 374). It is not known whether Descartes had read this passage, in particular. On the other hand, Descartes disapproved Clavius’ proposal, also evoked in the quoted passage, to solve the quadrature of the circle by the quadratrix, suitably redefined through a pointwise construction (see Euclid [1589], p. 894ff.). Since Clavius’ inquiry arguably presupposed the possibility of finding an exact proportion between straight and curves, its refusal by Descartes might have been also motivated by his adherence to the opposite conviction. Some interesting notes on this concern can be found in Isaac Beeckman’s *Journal*, at one time Descartes’ mentor: "Quadratura circuli estne possibilis? Respondeo: Si physicè dicas, maximè. Nulla enim res physica infinitè secatur; primordia igitur physica erunt communis mensura circuli et quadrati, ergo aequalis numerus talium mensurarum circulum et quadratum perficiunt. Verùm, quoniam haec eadem primordia physica hnoni infinitè secari possunt, dubitatur mathematicè, quamquam quadratum majus et minus dari possit, aut physicè aequale cogitari possit. Nec mirum. Recta enim rectae, et rectilineum rectilineo, est incommensurabile. Quidni ergo circularis linea ad rectam et circulus ad rectilineum ἀσύμμετρος dici posset?" (Beeckman [1939-1953], Vol. 1, p. 26, written around 1613–1614). It cannot be excluded that Descartes discussed with Beeckman about this issue too during the time spent with him in 1618-1619. This would suggest that Descartes was exposed, since his early mathematical education, to the thesis that rectilinear and circular magnitudes cannot be compared.

¹⁷ Cf. chapter 1, sec. 1.4.

unsolvability of certain problems by prescribed means (see ch. 1, sec. 1.4).

6.3 On the significance of early rectifications for Descartes' meta-statement

The general conviction that arcs of curves could not stand in an exact proportion started to waver soon after 1637.¹⁸ Nearly nine years later, for example, Mersenne pointed out in a letter to Torricelli that the problem of rectifying curvilinear arcs was an unsettled question worth being pursued:

Sexto gratissimum facies, si doceas quid nuper inveneris, quidque mente premas, gauderetque summopere Fermatius, si laborares in spiralibus, aut aliis curvis reperiundis, quae rectis lineis forent aequales, caret enim ejusmodi genio.¹⁹

By mentioning "... other curves equal to straight lines", Mersenne might want to refer to the rectification of algebraic curves too. As a further confirmation of this hypothesis, I recall that in a previous letter from 1645, Mersenne had inquired about the possibility of rectifying a portion of the parabola in a geometrical way (*vid.* Torricelli [1919], p. 269). These exchanges were but a preamble of an intense research started in the fifties - hence soon after Descartes' death - which led to important results concerning the rectification of geometrical curves, and eventually knocked on the head Aristotle's axiom.

One of the first outstanding results concerned the oft-invoked rectification of the parabola. In 1657, in fact, Huygens informed his recipients and associates that he had discovered the equivalence between the problem of rectifying a parabolic arc and the quadrature of a corresponding sector of an equilateral hyperbola. Huygens gave his result as a theorem, but omitted the proof (a sketch of Huygens' reasoning that might have led to the formulation of his theorem can be found in Hofmann [2008], pp. 106-107). Meanwhile, as we learn from Huygens' correspondence,²⁰ the dutch geometer Hendrick van Heuraet (1634-1660?) had reached the same result on the equivalence between the problem of the rectification of the parabola and the squaring of the hyperbola. Van Heuraet's discovery

¹⁸ Cf. Hofmann [2008], in particular chapter 8; Yoder [1988], chapter 7.

¹⁹ "And, sixthly, you will make such a beloved thing if you teach what you have just found, and which occupies your mind, and Fermat would be greatly pleased, if you worked on finding spirals, or other curves equal to straight lines. He lacks indeed of such an insight." (Paris 26th August 1646, in Torricelli [1919], p. 411).

²⁰ Cf., for instance, Huygens [1888-1950], vol. 2, p. 353.

was soon published in the second latin edition of Descartes' geometry (1659), as part of a letter with the title: "*Epistola de transmutatione curvarum linearum in rectas*" ("Letter on the transmutation of curves into straight lines").²¹

The "Letter on the transmutation of curves" contains a lot more than Huygens' result on the rectification of the parabola, as we come to know from the praise-worthy words of Frans Van Schooten, on the eve of its publication:

... he [namely, van Heuraet] has furthermore invented a Method (as he has shown to me by letter) with which he can rectify several curves absolutely perfectly (*perfecte omnino*). This he has explained so lucidly and briefly that he hardly required two pages for the whole work. Moreover, his method was such that what was said about the quadrature of the Hyperbola resulted from it smoothly as if it were a corollary (...) his Method for transforming curves is already in press and will come out one of these days. If God so wishes, along with the first part of Descartes' Geometria.²²

Van Heuraet's *Epistola* contains indeed, beyond the above-mentioned result on the parabola, a general theorem regarding the correspondence between rectifications and quadratures, from which a method for the rectification of algebraic curves could be derived, by reducing the problem of rectifying the arc of a given (algebraic) curve to the problem of the quadrature of a certain figure constructed from the given curve. In the same letter, van Heuraet offered two applications of his method: firstly, he obtained a rectification of an arc of quadrato-cubic parabola (namely, the curve of equation $y^2 = x^3a$),²³ and secondly he derived, as a "corollary" of his Method, to employ Van Schooten's terms, the result concerning the equivalence between the rectification of an arc of a parabola and the quadrature of an hyperbolic sector.

²¹Descartes [1659-1661], vol. 1, p. 517-20. For an English and Dutch translation of van Heuraet's piece see: Grootendorst A. W. [1982]. For an attempt to reconstruction van Heuraet's life and his mathematical achievements, see van Maanen [1984].

²²Huygens [1888-1950], vol. 2, p. 353. English translation in van Maanen [1984], p. 243.

²³Van Heuraet's rectification of the quadrato-cubic parabola was possibly the first published rectification of an geometrical curve, even if it must be recalled that during the same year Wallis gave, in his *Tractatus de cycloide*, an account of the rectification of a higher parabola obtained by the english mathematician William Neil. Fifteen years later, in 1673, a controversy arose between Wallis and Huygens concerning the priority of the first rectifications. The detailed study contained in Yoder [1988] allows me to eschew such questions of priority, and confine myself to evaluating the consequences that the early rectifications of geometrical curves had onto the reception of Descartes' geometry, and in particular on the reception of one of its cornerstones, namely the distinction between geometrical and mechanical curves and the related separation between possible and impossible problems.

The content of the mathematical discoveries deployed in the brief *Letter on the Transmutation of curves* has been explored in few detailed inquiries, reported in bibliography.²⁴ In the following lines, I will summarize the main points of van Heuraet's reasoning in order to understand why the *Epistola*, whose does not deal, apparently, with any of the themes treated by Descartes in his *Géométrie*, was appended as a commentary to this text.

Let us consider, firstly, the theorem stated by Van Heuraet. Let two curves AML and END (as in fig. 6.3), referred to the same axis AH , be given such that, for any point P on this axis, the perpendicular to AH from P meets the curves on two points, M and N , in such a way that:

$$PM : MG = K : PN \quad (6.3.1)$$

(MG being the normal to AML , and K a segment of constant length). If this condition holds, then the surface $BDCA$ equals the rectangle built on a segment K and another segment whose length is equal to the length of the arc \widehat{AML} , taken on the first curve, and corresponding to arc \widehat{CND} on the second.²⁵

In order to prove this theorem, van Heuraet did not rely on any of the algebraic techniques exposed in Descartes' geometry, but on the method of indivisibles and on the geometry of Euclid's *Elements*. In order to reconstruct his argument, let us suppose curves AML and END given (fig. 6.3), such that they comply with the only condition of satisfying proportion 6.3.1, once an arbitrary point M on the first curve has been chosen. I note that van Heuraet does not require these curves to be constructed, they need not be geometrical curves.

In order to complete the proof, let the tangent MF and the normal MG to the curve AML be also given. Being P the foot of the perpendicular from M to AH , let us take two points O and Q on AH , from opposite sides with respect to the perpendicular PM . Let also OU and QV , perpendiculars to AH from O and Q , be drawn. Next, let us suppose that MF cuts these perpendiculars in points I and T , respectively, and that IJ perpendicular to QV is dropped. At this point, Van Heuraet can exploit the fact that

²⁴See, in particular, Panza [2005], p. 119-132; van Maanen [1984]; Edwards [1994], for a rendering of Heuraet's argument with the tools of modern analysis.

²⁵Descartes [1659-1661], vol.1, p. 519.

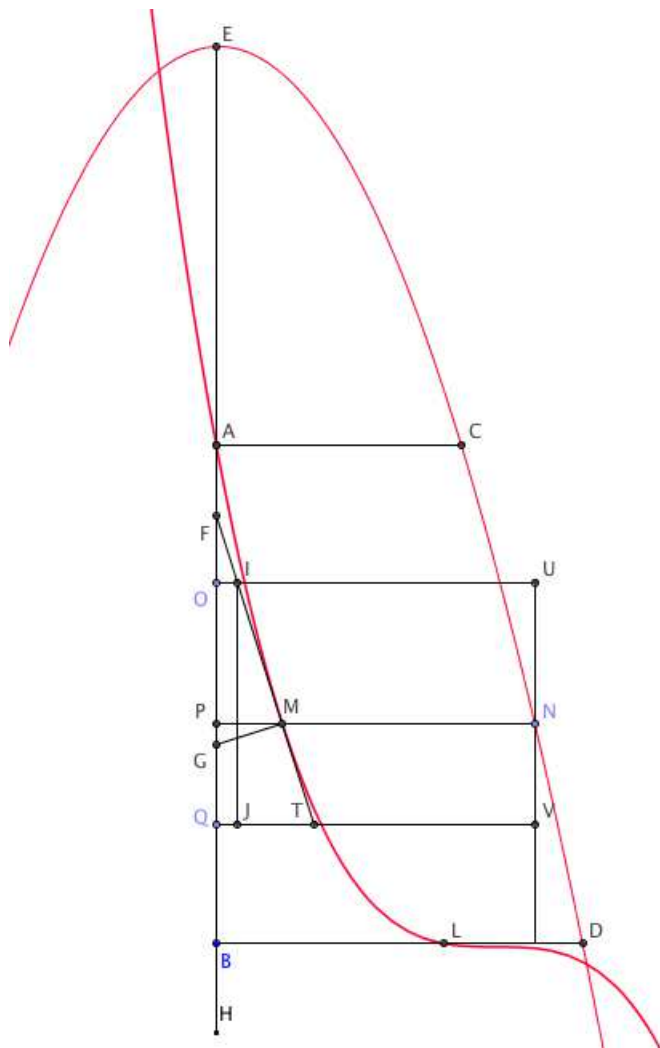

Figure 6.3.1: Van Heuraet's method for the rectification of certain algebraic curves.

two right angle triangles (PMG and IJT) have been constructed, in order to derive the following proportion:

$$PM : MG = IJ : IT.$$

If we compare it with the 6.3.1, we can infer:

$$IJ : IT = K : PN.$$

By applying Euclid VI, 16, it is immediate to conclude from the above proportion that rectangle $r(QV; UV)$, with sides $OQ = IJ$ and $QV = PN$ is equal to the rectangle constructed on IT and K :

$$r(QV; UV) = r(IT; K).$$

Van Heuraet's reasoning rests, so far, on an elementary geometric arguments: a triangle (IJT) is constructed similar to a given one (PMG), and from the comparison of their homologous sides a proportion can be written. This proportion allows van Heuraet, in its turn, to conclude the equality between the two rectangles $r(QV; UO)$ and $r(IT; K)$, stated above.

In order to pass from considerations of rectilinear figures and segments to considerations of curvilinear figures and arcs, and in order to compare them, van Heuraet resorts to a method akin to Cavalieri's method of indivisibles.²⁶

²⁶The basic conception in the backdrop of Cavalieri's method, exposed in the influential treatise *Geometria indivisibilibus continuorum nova quadam ratione promota* (1635. hereinafter: *Geometria indivisibilibus*) was to consider the surface of a plane figure or region (or the volume of a solid body) as the aggregate of all the chords (resp. all the planes) intercepted within the bounds of the figure when we trace infinitely many parallel lines crossing the figure itself. On the ground of this suggestive interpretation, Cavalieri could state a principle, that still bears his name: if two plane surfaces are cut by a system of parallel lines, which intercept corresponding equal chords over each figure, then also their surfaces are equal. If corresponding chords have a constant ratio, then the surfaces entertain the same ratio (for a presentation and discussion of Cavalieri's method, see Andersen [1986], and Giusti [1980]). As I will explain in more detail later, Van Heuraet seems to conceive the curvilinear surface $BNDCA$ as composed by rectangles with infinitely small height, rather than as an aggregate of all the chords. This was a current interpretation of Cavalieri's original ideas by the end of the fifties.

Van Heuraet's argument proceeds as follows: since the distance of O and Q from P has not been fixed, it can be taken arbitrarily small, and certainly sufficiently small that segment IT cannot be distinguished from the corresponding section of the curve AML , and the rectangle $r(QV; UV)$ cannot be distinguished from the corresponding portion of the curvilinear figure $BDCA$.²⁷

If we indicate, slightly anachronistically, with Δs the length of a small hypotenuse IT , tangent to the curve, and with Δx the length of a small leg IJ , then we can state the following proportion:

$$\Delta x : \Delta s = K : PN.$$

From which derives, by elementary geometry:

$$r(\Delta x; QV) = r(\Delta s, K).$$

If the arc of the curve AML between A and L is considered as the sum of all its small tangents (that we may indicate as follows: $\widehat{AML} = \sum \Delta s$), we can conclude from it that the curvilinear figure $BDCA$, equal to the sum of rectangles $r(\Delta x; QV)$ of infinitesimal width, is equal to the rectangle built on K and on a segment of length equal to the length of the arc \widehat{AML} , between points A and L , namely:

$$\sum r(\Delta x; QV) = r(\sum \Delta s; K). \quad (6.3.2)$$

The appeal to indivisibles or infinitesimals (namely rectangles or line-segments of infinitesimal breadth or length) is fundamental, in the proof of van Heuraet's theorem, in order to consider an arc of the curve AML (as the arc \widehat{AML} between points A and L in the example) as the sum of infinitely small sections of its tangents, each drawn to a point on the curve infinitely close to a point previously drawn, and the trapezoid $BNDCA$ as the sum of infinitely small rectangular sections. Only on this ground, in fact, van Heuraet

²⁷This point is made explicit, in particular, in Panza [2005], p. 121.

can establish that the the trapezoid $BDCA$ is equal to a rectangle whose sides are the segment K and a segment equal to \widehat{AML} , and therefore conclude the proof.²⁸

This proof concludes the first part of the *Epistola*. In the second part, van Heuraet expounds his method for rectification by solving few exemplary problems.²⁹ The two moments in which van Heuraet's tract can be divided are obviously related. Not only the theorem of van Heuraet is required in order to solve the first problem discussed in the text, namely the rectification of the quadrato-cubic parabola, but the very method for rectification, that shines through the examples discussed in the *Epistola*, can be envisaged as a synthetic reversal of the inferential path which led from 6.3.1 to the proof of van Heuraet's theorem. As a result of such a synthesis, van Heuraet explicitly conceives his method as a method of rectification, undergoing the following constraint: it does not permit to rectify an arc of any curve, but only arcs of curves associated to given curves, whose quadrature (or the quadrature of corresponding sectors) can be solved or has already been solved.

I observe that the applicability of van Heuraet's method is subject to another important restriction: in order to obtain the rectification of a proposed curve, it is required to solve the auxiliary problem of finding the normal MG for any point M on the curve. Since the example chosen by van Heuraet concerns the rectification of a particular algebraic curve, its normals can be determined with cartesian techniques. The appeal to cartesian geometry certainly facilitates the determination of the normal, but it is not necessary.

Let us then suppose to rectify an arc of the curve AML , expressed by the algebraic equation: $F(x, y) = 0$ with respect to the coordinate system with origin in P ($AP = x$ and $PM = y$). Since AML is an algebraic curve, its normal $MG = s$ can be expressed algebraically, using Descartes' method for tangents, exposed in *La Géométrie* and in few

²⁸In Van Heuraet's words (I point out that the letters used by Van Heuraet differ from the ones I have employed): "Quapropter omnia haec rectangula simul sumpta aequalia erunt rectangulo sub Σ & alia recta aequalia omnibus tangentibus simul sumptis. Unde cum illud verum sit, quotcumque rectangula atque tangentes extiterint, & figura ex parallelogrammis constans, si eorum numerus in infinitum augeatur, definat in superficiem $AGHIKLF$, ac tangentes similiter in lineam curvam $ABCDE$, liquet superficiem $AGHIKLF$ aequalem esse rectangulo sub Σ & recta aequali curvae $ABCDE$. Quod erat demonstrandum" ("Therefore these rectangles taken together will be equal to the rectangle contained by Σ [K in our notation] equal to the curve $ABCDE$ ", in Grootendorst A. W. [1982], p. 519).

²⁹As Heuraet avowed: "*methodum a me inventum, cujus beneficio complures curvae lineae (...) in rectas possunt transmutari*": "the method I have invented, by whose aid several curved lines can be transformed into straight ones", Descartes [1659-1661], vol.1, p. 517. See also Descartes [1659-1661], vol.1, p. 519.

remarks appended by Van Schooten in his commentary to the latin edition.³⁰

If PN is set equal to z , the equation of the second curve END can be obtained from the following system (the second equation figuring in the system is simply derived from 6.3.1):

$$\begin{cases} F(x, y) = 0 \\ zy = Ks \end{cases}$$

and by substituting y in the first equation. The curve END will be finally expressed by an algebraic equation in the unknowns x and z with respect to the same coordinate axes AP , MP : let us call the equation of END : $G(x, z) = 0$.

This result is obtained by the sole application of the cartesian machinery for algebraic manipulations on equations and for the method of tangents. On the other hand, in order to pass from the algebraic expression of the curve to an expression for the area subtended by the curve, namely, the trapezoid $ABCD$, Van Heuraet must suppose that measures of areas can be expressed, in general, in algebraic terms. The same supposition holds for the measure of arcs. Both moves demand, in order to be rigorously justified, an insight into the foundations of the theory of areas, which is lacking or is implicit in Van Heuraet's solution. Nevertheless, in order to work out the content of Van Heuraet's solution, we might proceed as suggested in (Panza [2005], p. 124ff.) and take momentarily for granted the algebraic expressability of areas and arcs.

Since the trapezoid $ABCD$ is conceived as the collection of infinitely small rectangles of ordinate z , varying from point A (with abscissa $x = 0$) and point B (with abscissa $x = \xi$), we can express its surface, according to the suggestion advanced in Panza [2005] (pp. 123-125), by the following symbol: $\sum_0^\xi [z]$. Similarly, the arc bounded by points A and L can be expressed by the symbol: $\Lambda_0^\xi [y]$. The result in 6.3.2 can be suitably reformulated as:

$$\sum_0^\xi [z] = R(K, \Lambda_0^\xi [y]).$$

³⁰See in particular Descartes [1659-1661], vol.1, p. 43-59, p. 246-253.

If $\sum_0^\xi[z]$ is expressed algebraically, for instance by a formula in which only the variable ξ occurs, then also $\Lambda_0^\xi[y]$ can be expressed algebraically, since it can be obtained as the result of the division of $\sum_0^\xi[z]$ by K (K being a constant, the algebraic expression for $\Lambda_0^\xi[y]$ will contain only the variable ξ).

This procedure is firstly applied by Van Heuraet to solve, by an analytical procedure, the particular problem of the rectification of an arc of a cubic parabola, of equation $y^2 = \frac{x^3}{a}$. The first step exposed by Van Heuraet consists in finding the normal MG for a point M of the curve. Van Heuraet reasons on the curve AML drawn within the system of orthogonal axes AH, BD .

If the normal MG to the point M is supposed already drawn in the diagram, its length can be computed applying Descartes' strategy. As prescribed by it, the problem of constructing a normal MG to a curve in one of its points M can be solved by constructing a circle with center G and radius MG , and posing the condition that the circle intersects the given curve AML in a double point.³¹

This geometrical condition can be expressed only analytically. Let us name the segments in the diagram as follows: $PM = y, AP = x, FQ = s, MG = v, PN = z, GP = s - x, GP^2 = s^2 - 2sx + x^2$. Since $GM^2 = y^2 = \frac{x^3}{a}$, applying Pythagoras' theorem one will find: $MG^2 = s^2 - 2sx + x^2 + \frac{x^3}{a} = v^2$.³² This is an algebraic equation (let us call it $\phi(x) = 0$) of the general form $f(x)^2 + (s - x)^2 - v^2 = 0$.

The analytical counterpart of Descartes' geometrical condition for the double point is expressed by the condition that equation $\phi(x) = 0$ possesses a double root. In order to find the (double) root of $s^2 - 2sx + x^2 + \frac{x^3}{a} = v^2$, and thus find $s(= FQ)$ and $v(= MG)$, van Heuraet employs Hudde's method, an algorithm which simplified Descartes' techniques exposed in *La Géométrie*.

Without entering the details of the algorithm,³³ I will limit myself to state the final result obtained for the segment s , namely: $s = FQ = x + \frac{3x^2}{2a}$, and for segment GP , equal to $\frac{3x^2}{2a}$. Another application of Pythagoras' theorem will give us the length of the normal $v = MG = \sqrt{\frac{9x^4}{4a^2} + \frac{x^3}{a}}$.

³¹See Panza [2005], pp. 83-118, and also Giusti [1986], pp. 26-37.

³²Descartes [1659-1661], vol.1, p. 519.

³³An exhaustive explanation can be found in Panza [2005], pp. 104-113. See also Whiteside, *Newton Mathematical Papers*, I, pp. 213-215.

By setting $K = \frac{1}{3}$ (as Van Heuraet remarks, K can assume arbitrary values: "*licet enim pro libitu assumere*"), 6.3.1 will yield:

$$PN(= z) = \sqrt{\frac{1}{4}ax + \frac{1}{9}a^2}.$$

It results that the curve $G(x, z) = 0$ associated to the semi-cubical parabola of equation: $y^2 = \frac{x^3}{a}$ is a parabola with vertex E , such that $EA = \frac{4}{9}a$, and *latus rectum* $\frac{1}{4}a$.³⁴

Without further explanation, van Heuraet concludes that the length of arc \widehat{AML} measures $\sqrt{\frac{\chi^3}{a} - \frac{8}{27}a}$, with $\chi = EB = AB + EA = x + \frac{4}{9}a$.³⁵

Van Heuraet possibly assumes that the region under by the curvilinear figure $ABCD$ is expressed by the algebraic formula: $\sum_0^\xi[z] = \frac{1}{3}(\sqrt{\frac{\chi^3}{a} - \frac{8}{27}a})$ (in this case, $\xi = AB$).³⁶ Consequently, the length of \widehat{AML} can be obtained by dividing the value of the area by $K = \frac{1}{3}$:

$$\Lambda_0^\xi[y] = \frac{\frac{1}{3}(\sqrt{\frac{\chi^3}{a} - \frac{8}{27}a})}{\frac{1}{3}} = \sqrt{\frac{\chi^3}{a} - \frac{8}{27}a}.$$

The second example discussed by Van Heuraet concerns the rectification of a parabolic arc, and had a different, "negative" outcome. Indeed, let the parabola $y = \frac{x^2}{a}$ be given. The subnormal PG , determined by Hudde's rule as in the previous case, is equal to $\frac{2x^3}{a^2}$, whereas the normal PS is equal to $\frac{4x^6}{a^4} + \frac{x^4}{a^2}$. By setting $K = a$, the curve associated to the parabola will be defined by the equation $z = \sqrt{4x^2 + a^2}$, which expresses an hyperbola. Hence, van Heuraet's procedure showed that the rectification of the parabola depended on the quadrature of this figure, an unsolved quadrature at his time. For this reason

³⁴Descartes [1659-1661], vol.1, p. 520.

³⁵Descartes [1659-1661], vol.1, p. 520. Note that van Heuraet employs the symbol ν to denote segment EB .

³⁶Van Maanen and Grootendorst suggest that van Heuraet might have relied on well-known results by Cavalieri, who had given the quadratures for the class of paraboloids of cartesian equation: $y = x^k$, with k a positive natural number (see Grootendorst A. W. [1982], p. 108). Yoder refers directly to Archimedes' result on the quadrature of a parabolic sector, that van Heuraet certainly knew as well. I will sketch below a possible reconstruction of van Heuraet's reasoning based on the archimedean quadrature.

Van Heuraet concluded his letter not by solving the rectification of the parabola, but by merely pointing out the relation between the two problems.³⁷

From the survey of van Heuraet's main contributions to the rectification of curves, it is clear why this inquiry was appended to a translation of Descartes' geometry: it provided in fact an unsuspected application of algebraic techniques, developed by Descartes in order to solve the problem of tangents, into the different problem of rectifications.

Van Heuraet's mathematical results were hailed by his contemporaries as momentous achievements. F. de Sluse (1622-1685), for instance, who entertained in the fifties a rich correspondence with Schooten and Huygens, and was therefore informed on the latest results concerning the rectification problem, thus commented on the recently published letter on the rectification of curves:

Novum autem illud de Parabolicae lineae, et Hyperboles dimensionis mutuo nexu, dici non potest quantum mihi placuerit, praesertim cum Heuratio occasionem dederit inueniendj rem quam inter ἀδύνατα hactenus recensueram. In quo errore et Cartesium et plures alios, vt scis, socios habuj; ideoque maximo desiderio teneor videndj Commentarij Schoteniianj, cuius editionem postremam nondum aspexi . . .³⁸

Sluse evokes, in this passage, the equivalence ("*mutuo nexu*") between the rectification of an arc of the parabola and the quadrature of an hyperbolic sector as a fundamental discovery leading to another one, associated with van Heuraet's name. This result consists, in all likelihood, in the analytical rectification of an arc of a quadrato-cubic parabola, a result that Sluse himself - so we read in the passage reproduced above- together with several other geometers (including Descartes) erroneously ranged "among impossibilities". We can read here a reference to the axiom about the incomparability between straight and curved, against which the application of Heuraet's method provided an astounding counterexample.

³⁷"Quod ipsum docet, longitudinem curvae Parabolicae inveniri non posse, quin simul inveniatur quadratura Hyperbolae, & vicê versa", Descartes [1659-1661], vol.1, p. 520. In van Maanen's and Grootendorst's translation: "and from this exactly we learn that the length of the parabolic curve cannot be found unless at the same time the quadrature of the hyperbola is found, and vice versa." (Grootendorst A. W. [1982], p. 105).

³⁸Huygens [1888-1950], vol. 2, p. 354: "It cannot be said how far I enjoyed this news about the parabola and its mutual relation with the quadrature of the hyperbola, in particular, because it gave to van Heuraet the occasion to discover a thing that I have so far confined among the impossible [ἀδύνατα]. As you know, Descartes and several others were fellows to me in such an error. Thus I am gripped by desire to see the Commentary of Schooten, whose last edition I have not yet looked upon".

Henk Bos suggests, in Bos [1981] and in Bos [2001], that the first rectifications of algebraic curves might have represented more than a refutation of an axiom or a dogma believed for a long time (a conclusion that, as attested by the excerpt reproduced above, was taken also by Sluse). In fact, Bos argues that by refuting the incomparability of straight and curves, the first rectification of geometrical curves would also undermine the fundamental dichotomy, in Descartes' classification of curves, between geometrical and mechanical ones.³⁹

However, Bos' conjecture on the revolutionary character of the first rectifications clashes against an obvious historical fact, stressed in Mancosu [1999] (p. 77-78), and Mancosu [2007] (pp. 119-120): not only van Heuraet's rectification of the semi-cubical parabola was inserted in the second latin edition of Descartes' geometry (1659) as an exemplification of cartesian method, but no one at that time nor during the following years, claimed that this result undermined the foundations of Descartes' geometry.

I think that these objections are sound. But I also point out, with Mancosu,⁴⁰ that it is sufficient to hold, as a 'meta-statement', the non-comparability between straight segments and circular arcs (that is, the impossibility of stating exactly a proportion between the two kinds of quantities) in order to demarcate as ungeometrical curves like the quadratrix, the spiral and the helix, known to Descartes via ancient sources.

Indeed van Heuraet's method for rectification did not succeed in refuting the non-comparability between segments and circular arcs. Only an algebraic rectification of the circle and of its arcs, or equivalently, the algebraic quadrature of the circle, that we know to be impossible, would achieve such a refutation. Hence, the contemporaries of van Heuraet probably realized that the restrictions inherent to the latter's method of rectification (restrictions analyzed above) rendered it unfit in order to tackle the problem of rectifying an arc of the circle, and therefore they also realized that van Heuraet's method could not threaten the foundational edifice of Descartes' geometry.

On the other hand, I surmise, one must be also cautious in excluding that the early rectifications of algebraic curves, like the one obtained by means of van Heuraet's method,

³⁹Compare, in particular, Bos [2001], p. 342: "The central role of the incomparability of straight and curves in Descartes' geometry was the reason why the first rectification of algebraic (i.e. for Descartes: geometrical) curves in the late 1650s were so revolutionary: they undermined a cornerstone of the edifice of Descartes' geometry".

⁴⁰This proposal has been advanced in the work evoked in the previous note.

had any consequences on the reception of Descartes' geometry and on Descartes' belief about solvable and unsolvable problems. It should be pointed out that Descartes plausibly grounded his conviction about the non-comparability between straight segments and circular arcs on a preliminary conviction on the non comparability between straight and curvilinear magnitudes, whose universality, at least, was refuted by van Heuraet.

The following conjecture can be ventured: even if the first algebraic rectifications of algebraic curves did not refute the conviction that the rectification of circular arcs was impossible, and therefore they did not directly undermine the distinction between geometrical and mechanical curves, one of the cornerstones of Descartes' geometry, yet they partly undermined the grounds of this conviction.

Probably as a consequence of such undermining, in 1667, less than ten years after the second latin edition of the geometry was published, James Gregory was still dubious about whether the quadrature of the circle could be solved by cartesian means, and eventually came up with a negative answer, published in his *Vera Circuli et Hyperbolae Quadratura*.

6.4 Problems of quadratures and the problem of area

In my effort to clarify and interpret van Heuraet's solution, I have expressed the length of the arc of quadrato-cubic parabola through the following symbolic notation: ' $\Lambda_0^\xi[y] = \frac{\Sigma_0^\xi[z]}{K}$ '.⁴¹ The expression: ' $\Sigma_0^\xi[z]$ ' represents the area of the section of the parabola delimited by abscissas 0 and ξ , and the expression: ' $\Lambda_0^\xi[y]$ ' represents the length of an arc between the same abscissas.

So far, I have not questioned how a seventeenth century geometer like van Heuraet might have understood the concepts of area and arc-lengths. On this concern, Van Heuraet's account, at least the one published in the *Geometria*, is not illuminating either. In fact, Van Heuraet employs the symbolism of Descartes' algebra of segments in order to express the length of an arc and the area of a figure, without justification. Van Heuraet's reticence on this concern leaves us with crucial questions: was the algebraic formalism employed by van Heuraet in order to express the measure of a surface and a arc the same as Descartes' formalism for the algebra of segments? And which tacit conditions

⁴¹This notation is employed in Panza [2005], p. 122ff.

made such an extension of the cartesian symbolism possible and accepted without any objection?

Problem of quadratures were dealt with, in the period 1630-1660 ca., by a number of mathematicians who tried to constitute a general framework in order to solve the largest possible number of quadratures of special figures, by combining the cavalierian method of indivisibles with arithmetic procedures. On the contrary, the formalism of Descartes' algebra of segments was not employed, in this framework, in order to solve quadrature problems.

The reason was not accidental, but can be found in the difficulty of expressing the result of quadrature and correlatively with rectification problems through the algebra of segments exposed in *La Géométrie*. At least for what concerns quadratures, this difficulty was not related to any explicit methodological *caveat*: whereas Descartes explicitly denied, in *La Géométrie*, that problems of rectifications could be solved in an exact way, he simply eschewed discussing quadrature problems. On the other hand, I surmise that the possibility of extending the algebra of segments in order to obtain an assertive and determinative algebra, capable of treating problems of quadrature and rectification, conflicts with two major conceptual problems. The first one is related with the concept of surface as magnitudes, and the other with a limitation inherent to Descartes' algebra of segments.

Let us consider the first problem. Given a pair of polygons (α, β) it is always possible, relying on Euclid's plane geometry, to constructively determine whether: $\alpha < \beta$, $\alpha = \beta$ or $\beta < \alpha$, and to endow with a geometric meaning the result of the addition $\alpha + \beta$. On the ground of *El.* VI, 25 we can construct two rectangles A and B , having the same height, and being equal to polygons α and β respectively. It will be therefore easy, on the basis of the *Elements*, to compare these rectangles, in order to determine whether $A < B$ or $B < A$, and to construct the rectangle $A + B$.⁴²

Once clarified this point, we can define an assertive 'algebra of polygons' on the model of the algebra of segments (a supplementary problem, on which I will not enter, would be to endow this algebra with a determinative character: in order to do this, we should also be capable of constructing the product and division of two polygons, and offer a geometric interpretation for the operation of extracting its square root, for example).

⁴²Panza [2005], p. 2-6Mueller [2006], p. 122.

On the contrary, the possibility of comparing trapezoids among them and with rectilinear figures (i.e. polygons) cannot be established in an equally general way, either relying on Euclid's plane geometry or in other available theories to early modern geometers. It is true that in ancient mathematical practice, polygons and curvilinear figures could be compared employing a variety of techniques, and certain quadrature problems could be thereby solved in an exact, rigorous way.⁴³ But the very method of exhaustion was classically applied for the quadrature of particular figures, from which one could not extrapolate general conditions that allowed not only to compare rectilinear and curvilinear figures involved in specific problems, but in general, to compare arbitrary curvilinear and rectilinear figures (for instance curvilinear regions, or trapezoids, bounded by geometrical curves). This would represent a noticeable difficulty against the setting up of an assertive algebra holding of figures in general, either curvilinear and rectilinear ones.⁴⁴

The second qualm against the possibility of treating quadrature problems in an algebraic way can be briefly stated: even if we had a criterion in order to compare and add curvilinear figures, a problem would remain concerning how to denote, using Descartes' algebra of segments, a trapezoid as a magnitude. Indeed any operation on segments will always yield, within the cartesian formalism, a segment as a result. How can the algebra of segments be employed in order to express a different magnitude than a segment, for instance a polygon or a curvilinear figure?

Probably aware of the difficulty of explicating and incorporating these conditions within the structure of the cartesian algebra, Descartes accurately avoided to mention quadrature problems in his treatise, and even when he dealt with them, outside of *La Géométrie*, he employed several techniques (included the method of exhaustion) arguably without the intent of constructing a unifying procedure (namely a calculus) analogous to the one developed in *La Géométrie*.

But, as a survey of XVIIth century mathematics will confirm, the silence of van Heuraet on the rationale and motivations of his application of the cartesian formalism to areas and arcs is not surprising. It seems that no argument was explicitly given, in XVIIth or XVIIIth century, in order to ground the extension of algebraic symbolism from segments

⁴³For an overview of ancient examples, see Baron [1969], chapter 1.

⁴⁴On the XVIIth century discussions around the problem of redefining the classical notion of equality, in order to cope with the problem of comparing rectilinear and curvilinear figures, see de Risi [2007], p. 150ff.

to areas: either cartesian algebra was ignored when dealing with problems of area, or the possibility of its extension was tacitly assumed, like Van Heuraet did.⁴⁵

In the absence of any explicit position held by XVIIth century mathematicians, it is still possible to venture a conjecture in order to explain under which conditions the expression ' $\frac{a}{3}(\sqrt{\frac{x^3}{a}} - \frac{8}{27}a)$ ', that would denote a segment, in the framework of cartesian geometry, can tacitly refer to an area, in the context of Van Heuraet's work. The hypothesis I want to propose and endorse here has been advanced by M. Panza, in his Panza [2005] (see, in particular, the discussion at pp. 125-128).

As a first remark, it should be pointed out that no general formal restrictions enjoin geometers from employing symbols, that in the formalism of cartesian algebra denote segments, in order to express magnitudes other than segments.⁴⁶ We might, therefore, envisage to employ symbols belonging to Descartes' algebra of segments in order to measure, within the the domain of segments, other magnitudes, like the surface of a plane bounded region. In order to understand how this process is in principle possible, and how it might have effectively occurred, I will start from a basic example. Formulas for computing the areas of figures are among the basic facts of elementary geometry: for instance, the area of a parallelogram is the product of its base and its height; the area of a triangle is $\frac{1}{2}$ of the product of its base and height. But measuring a surface via the application of these formulas requires several presuppositions.⁴⁷ For instance, such presuppositions may include the availability of a number system endowed with multiplication, and a way of assigning numbers to lines and figures in order to express their lengths and breadth, respectively. Thus, when someone states that: "the area of a parallelogram $ABCD$ is the product of its base α and its height β , namely: $A(ABCD) = \alpha\beta$, he is not using, in this context, the symbols ' α ' and ' β ' as names for two segments, but as measures of these segments, expressed for instance through numbers.⁴⁸

⁴⁵Panza [2005], p. 127.

⁴⁶Cf. ch. 3, p. 120ff.

⁴⁷Cf. also ch. 1, sec. 1.4.1.

⁴⁸According to the interpretation of Descartes' geometry I have endorsed in this study, the formula stating: "the area of a parallelogram is the product of its base and height" works in an utterly different way with respect the formalism of Descartes' algebra of segments: in the latter, symbols denote segments, not the measures of these segments. For a discussion of the modern concept of area, see Moise [1990], chapter 13 and 14.

Taking the lead from this remark, I observe that another way can be envisioned to measure the content of a figure, avoiding the appeal to numbers.⁴⁹ To this effect, let us consider once again the elementary example of the parallelogram. Its base AB and height DH are segments that can be denoted, within the cartesian formalism, with letters, e.g: ‘ a ’ and ‘ b ’. These letters do not express any measure, but denote the segments themselves. Hence, according to the internal multiplication in force within Descartes’ algebra of segments, we can write the product of a and b as: $ab = c$, where ‘ c ’ denotes a segment too, namely the unique segment which satisfies the proportion: $1 : a = b : c$.

But it can also be supposed that c , while denoting the product of segments a and b , expresses the area of the rectangular region whose base and height are, respectively a and b .⁵⁰ More generally, it can be supposed that a segment x can measure, in the domain of segments, a magnitude X different than a segment, provided x behaves with respect of any other segment in the same way that X behaves with respect to the magnitudes of the same kind. In order to refer to the fact that the segment x measures X in the domain of segments, one may adopt the following notation, following (Panza [2005], p. 128-129):

$$s[X] = x.$$

I stress that such a supposition and the consequent correspondence between segments and magnitudes other than segments (for instance, surfaces or volumes) is not made explicit either by Van Heuraet or by any other early-modern geometer. However, it is arguable that the algebraic measure of the parabolic surface obtained by Van Heuraet might be inferred from algebraic expressions denoting segments, by means of procedures that comply with the theory of proportions and with the metrical relations licensed by it.

⁴⁹The possibility of measuring the content of a two-dimensional figure was rigorously proved in David Hilbert’s *Grundlagen der Geometrie*, for the first time. Roughly speaking, Hilbert proved that it is possible to associate to the content of a figure a certain area-function with values in the additive group of segment arithmetic, which is itself isomorphic to the field of the real numbers. If the existence and unicity of this function are proved (as it is done in the *Grundlagen der Geometrie*) then the area of a rectilinear figure can be measured by associating to it a certain value expressed by a member of the field of segment arithmetic. Obviously, the axiomatic treatment provided in Hilbert’s foundational work cannot be found anywhere in XVIIth century mathematical thought, and it would be an anachronism to suppose the contrary.

⁵⁰Moise derives the theorem in a rigorous way, stating that the area of a parallelogram is the product of its base and its height can be derived from the postulates defining an area-function (Moise [1990], p. 185-186).

In order to understand this crucial claim, I will propose a plausible reconstruction of van Heuraet's inferential path leading from the derivation of the algebraic expression for the parabola associated to the curve to be rectified, to the algebraic determination of the arc-length of the semi-cubical parabola.

The most direct way to square geometrically the parabolic sector $ABDC$ (fig. 6.3) would be to consider it as the difference between the parabolic sector $EBDC$ and the sector $ECAE$ (the conclusion is obvious on the ground of the diagram), and then to square sectors $EBDC$ and $ECAE$ by relying on known procedures, like Archimedes' quadrature of the parabola. Since the parabola $z = \sqrt{\frac{1}{4}ax + \frac{1}{9}a^2}$ has EB as axis, vertex in E and *latus rectum* equal to $\frac{1}{4}a$, the following equalities can be immediately derived: $EBDC = \frac{2}{3}R(EB, BD)$, $EACE = \frac{2}{3}R(EA, AC)$.⁵¹ On this ground, each parabolic sector can be squared, according to a classical, euclidean procedure: it is sufficient to construct a rectangle equal to two thirds of the rectangle with sides EB and BD , and transform it into a square. Once the quadratures of the two sectors have been accomplished, the quadrature of the sector $ABDC$ immediately follows: it is sufficient to take the difference between the square equal to the sector $EBDC$ and the square equal to the sector $ECAE$, and transform this difference into a square.

In order to express this solution algebraically, Van Heuraet might have proceeded in the following way. By simplicity, one may choose point E as the origin of the axis, so that the equation of the parabola with respect to the new origin will be: $z = \frac{1}{2}\sqrt{a^2x}$, and: $EACE = \frac{2}{3}R(\frac{4}{9}a, \frac{1}{3}a)$ and $EBDC = \frac{2}{3}R(\chi, \frac{1}{2}\sqrt{a\chi})$, if $\chi = EB = AB + EA = x + \frac{4}{9}a$.

If it is assumed that the surface of a rectangle is measured in the domain of segments by the segment equal to the product of its sides, then the geometric relation between parabolic sectors, namely: $ABDC = EBDC - ECAE$, yields the area $\sum_0^\xi[z]$ of the sector $ABDC$ in algebraic terms (in virtue of the change of the origin, we are now looking for the area of the trapezoid $ABDC$ between the abscissa $x = \frac{4}{9}a$ and the abscissa $x = \frac{4}{9}a + \xi$, but I note that the area can be assumed as an invariant with respect to any transformation

⁵¹Both results can be inferred as corollaries from Archimedes' *Quadrature of the parabola*, proposition 17 (Archimedes [1881], vol. 2, p. 335). In Heath's paraphrase: "the area of any segment of a parabola is four-thirds of the triangle which has the same base as the segment and equal height" (Heath [1897], p. 246).

of the coordinates involving the translation of the origin along one axis):

$$s[\sum_0^\xi [z]] = \frac{2}{3}s[R(\chi, \frac{1}{2}\sqrt{a\chi})] - \frac{2}{3}s[R(\frac{4}{9}a, \frac{1}{3}a)] = \frac{1}{3}a\sqrt{\frac{\chi^3}{a}} - \frac{8}{81}a^2$$

In other words, the segment measuring the surface $ABDC$ in the domain of segments, namely $s[\sum_0^\xi [z]]$ is equal to $\frac{2}{3}$ of the segment equal to the difference between the segments measuring the surfaces of rectangles $EBDC$ and $EACE$, respectively.

The algebraic expression ' $\frac{a}{3}(\sqrt{\frac{\chi^3}{a}} - \frac{8}{27}a)$ ' can therefore denote a segment, in full compliance with the cartesian formalism, and at the same time express the measure of a surface (hence, a magnitude different than a segment).

In virtue of Van Heuraet's theorem, moreover, the surface of the trapezoid $ABCD$ is equal to a rectangle bounded by a segment K and by the arc \widehat{AML} , in symbols: $\sum_0^\xi [z] = R(K, \Lambda_0^\xi [y])$. In order to infer from the measure of the trapezoid the measure of the arc \widehat{AML} , Van Heuraet arguably made two simple, but tacit assumptions. Firstly, an assumption, already in force in the deduction of the algebraic measure of $ABCD$, is required: a rectangle is measured, in the domain of segments, by the product of its sides. Secondly, van Heuraet had to assume the following too: if a magnitude A is measured by segment α , then any magnitude $B = A$ (provided a suitable notion of equality has been given within the class of magnitudes to which A belongs) is measured by the same segment α .

Hence, if the area $\sum_0^\xi [z]$ is measured by segment $\frac{a}{3}(\sqrt{\frac{\chi^3}{a}} - \frac{8}{27}a)$, according to the above conclusion, the area of $R(K, \Lambda_0^\xi [y])$ will be measured by the same segment. Consequently, the length of side $\Lambda_0^\xi [y]$ will be expressed by the quotient: $\frac{\frac{a}{3}(\sqrt{\frac{\chi^3}{a}} - \frac{8}{27}a)}{K}$, in agreement with the result found in van Heuraet's *Epistola*.

On the methodological level, the conclusion reached by van Heuraet contains a simple but deep consequence. In fact, it shows that the scope of the formalism of (determinative) cartesian algebra could be extended to the measuring of curvilinear surfaces bounded by algebraic curves and to arc-lengths of algebraic curves. It should be pointed out, however, that Van Heuraet limited the range of application of his method, and therefore of his

representational innovation too, to the sole case of the parabola, whose quadrature was known since antiquity, and therefore did not present any difficulty) and to the rectification of its associated curve, namely the quadrato-cubic parabola. Despite van Heuraet's confidence that his method for rectification would be applicable to the family of curves with equations $y^{2n} = \frac{x^{2n+1}}{a}$,⁵² it is not clear how the rectification of these higher parabolas might be obtained, since van Heuraet did not possess a procedure in order to square the associated sectors or, at any rate, he did not report such a method in any known text.⁵³

⁵²Descartes [1659-1661], vol. 1, p. 520.

⁵³*Cf.* van Maanen [1984], p. 268; Panza [2005], p. 129.

Chapter 7

James Gregory's *Vera Circuli Quadratura*

7.1 Introduction: the quadrature of the circle

Descartes' *Géométrie* contains explicit criteria for separating acceptable from non acceptable solving methods, thus demarcating the ontology of Descartes' geometry and its strength in problem solving.¹ However, in this treatise there are no further distinctions between acceptable and non acceptable problems, in analogy with the distinction between permissible, or geometrical, and non permissible, or mechanical curves. In particular, I have found, in the context of Descartes' mathematical production, no use of the word "mechanical" with reference to problems.²

A criterion for classifying problems was delineated, as I have discussed before, in a letter to Mersenne from 1638. According to my reading of it, Descartes grounded on the techniques presented in his *Géométrie* a sketchy distinction between possible and impossible problems, according to whether the content of a given problem could be reduced to an equation, and thus the problem admitted a geometrical solution. Probably reminiscent of the traditional view on the non rectifiability of circular arcs in geometry, Descartes denied that such a reduction was possible in principle, for the case of the squaring of the circle.

¹See, for instance Jullien [1999], Panza [2005], Panza [2011].

²It seems that later writers, when commenting upon Descartes' geometry, simply overlooked these terminological restrictions. On this, confront Collins' remarks on Descartes' *Géométrie* (Hofmann [2008], p. 203).

Obviously, proving that a problem can be solved mechanically (as it is the case, for instance, of the squaring of the circle or the rectification of its circumference) is not sufficient to exclude it from geometry: the trisection of the angle, for instance, can be solved either using a mechanical curve like the quadratrix, or an acceptable construction through a couple of geometrical curves. Nothing could have prevented, in principle, a XVIIth century mathematician to conceive that a similar situation would hold also for a problem like the quadrature of the circle, that can be solved, to our knowledge, solely on the basis of mechanical methods.³

Moreover, the circle-squaring problem possesses this further peculiarity: while it could not be allegedly expressed through an algebraic equation, nor solved by intersection of geometrical curves, its content could be understood without appeal to notions extraneous to Euclid's plane geometry.⁴ This might have been one of the reasons why efforts towards a solution by euclidean means were recorded for at least two centuries after the period we are considering, and it might also have been the occasion of more serious reflections on the relationships between cartesian analysis and the non algebraic methods adopted by ancient geometers.

Early modern geometers, and particularly cartesian geometers, were concerned with such considerations, as a tract written by Frans Van Schooten: *De concinnandis demonstrationibus geometricis ex calculo algebraico* might show.⁵ The preface of this text, written by Pieter Van Schooten (Frans' brother), who also published this text, after Frans van Schootens' death, maintains two broad claims that would soon become commonplace opinions concerning algebraic methods in geometry. The first claim is that algebra, understood as an analytic art, has been accurately concealed by ancient mathematicians, who "exhibited only the synthesis, in a vulgar form". Therefore, the analytical method has been forgotten, and its certainty occasionally cast into doubt. In fact, in Pieter Van Schooten's words, his brother:

...neque dubitabat, quin pleraque omnia, quae Veteribus tantum gloriae peperissent, Analyseos beneficio ac ope reperta essent, sed quae illi, ut inventorum maior admiratio foret, dissimulato hoc artificio et suppresso, vulgari

³I recall that the observation is made by Mancosu [2007], p. 117.

⁴One could object that the notion of "circle" as a magnitude is never introduced in Euclid's plane geometry, because Euclid never offers a procedure in order to sum circles. This claim is debatable, though, since a suitable generalization of Pythagora's theorem to semicircles would be sufficient to introduce an operation of addition among circles. Nevertheless, it doesn't seem to me that, even if the circle is never defined as a magnitude in the Elements, the meaning of the problem of squaring the circle remains.

⁵This tract is contained in Descartes [1659-1661], vol. 2.

tantum syntheseos forma exhibuissent. Sed cum Veterum dissimulatione factum videret, hunc Analyticae methodi praestantem usum non modo a multis ignorari ac negligi, sed ipsam ejus certitudinem ac evidentiam a nonnullis suspectam haberi . . .⁶

The second broad claim is that the algebraic method employed in cartesian geometry is able to translate and demonstrate everything that can be expressed in the language of pure geometry and that, conversely, every algebraic inference corresponds to a geometric inference. This correspondence would be sufficient to warrant, in Van Schooten's view, the legitimacy of using algebra in order to solve geometric questions:

Ipsum quoque syntheticum demonstrandi modum in analysi contineri atque ex ea elici posse; ut eo argumento quemvis convinceret, quantum illa et prevaleat, et praeferenda sit.⁷

Nevertheless, the vocation of algebra as a universal language of geometry - this was, at least, the ideal endorsed by Van Schooten - was hindered by two general quandaries. This first one concerned the applicability of the cartesian model of analysis: could all the concepts and operations of geometry be translated into algebraic operations? The second one was the reciprocal problem: could all concepts and operations of algebra be translated into geometry?

The problem of trisecting an angle already constituted a major stumbling block to a mathematician like Ghetaldi, who was skeptical as to whether this problem could fall under algebra, because its formulation concerned a magnitude like an angle, and not line segments.⁸ However, the treatments of Viète and later of Descartes illustrated that the problem of trisection can be easily converted into an equation, namely a proportion between segments. However, reducibility of geometric problems to algebra remained an open question for other problems.

⁶*Geometria*, vol 2, p. 343. "...did not doubt, that most of these achievements, which engendered so much glory for the Ancients, had been obtained with the benefit and aid of Analysis, but that they concealed and suppressed this technique and, in order to increase the wonder for their discoveries, they exhibited them only in the vulgar form of the synthesis. But although this appeared to be caused by the dissimulation of the Ancients, the rewarding use of the analytical method not only was ignored and neglected by many, but its very certainty and evidence was suspected by several people". My understanding of the programmatic aspects of this treatise is particularly indebted to Brigaglia [1995].

⁷Descartes [1659-1661], vol 2, p. 343. "Also, the very synthetical method of proof is contained in analysis, and can be derived from it. Therefore by this argument anyone can be convinced, how much analysis is more fruitful and preferable than synthesis".

⁸See Panza and Roero [1995], p. 225.

The impossibility of solving the circle-squaring problem was occasionally evoked in connection with this issue. In the same spirit of Frans Van Schooten's, the question about the range of problems that may fall under the scope of analysis is explicitly posed in the preface of a work written by François Dulaurens: *Specimina mathematica* (1667).⁹

Here Dulaurens offers a summary or plan of his work, and in the end of it he evokes some theoretical problems arisen with analysis – namely the analysis of the moderns, in which Dulaurens conflated both Viète's *Ars Analytica* and Descartes' algebra of segments. In particular, the author points to a still unachieved or possibly unachievable part of analysis, concerning the reducibility to equations of problems dealing with as quadratures or cubatures:

Restat Analyseos pars altera, quae nonnullas questiones spectat, pro quibus solvendis impossibile, aut admodum difficile est ad aliquam aequationem pervenire, quales sunt fere omnes quae planorum, vel solidorum curvilineorum quadraturas, aut cubationes investigari proponunt.¹⁰

Among such difficult questions we find problems of rectification. Probably Dulaurens was thinking about the rectifications of circular arcs, when he observed that, in cartesian geometry: "... nam in hujusmodi questionibus media desunt, aut saltem difficillime apparent ad instituendam curvi cum recto comparationem ...".¹¹

Indeed Dulaurens mentioned the circle-squaring problem, for which no equation had been produced in order to infer a construction by geometrical means, so that the sole solutions available were still those of the ancients, by means of mechanical curves like the quadratrix.¹²

⁹Dulaurens' book was an elementary treatise in algebra, illustrating the recent advances in the field brought by Descartes, Harriot and Viète. The second part has some interest, though, as Dulaurens studies there the solutions of 5th and 7th degree equations, in connection with the geometric problem of angular sections. He obtained, for these specific cases, a resolute formula, that enabled him to express one root numerically, in terms of the coefficients. The book became however known as a result of a polemic with John Wallis, whose name was mentioned in the *Specimina* in connection with an algebraic problem that he had presumably proposed. Wallis denied furiously that he had any part in this, and attacked Dulaurens and his *Specimina*. Thanks to this attack, the book became known to Collins, and through it, to Gregory as well (See Stedall [2011], p. 59-60).

¹⁰"There remains another part of analysis, which concerns several questions, for whose solution it is impossible or very difficult to obtain an equation, as are almost all those that ask to investigate quadratures of plane or curvilinear solids, or their cubatures" (from the preface, unnumbered sheet).

¹¹"... indeed the means are lacking in questions of this kind, or at any rate they seem to be very difficult [to find], in order to establish a comparison of the curve with the straight." (*pref.*).

¹²"Nulla aequatio elici potest ad propositam circuli quadrationem arguendam ... " ("No equation can be set out in order to solve the proposed quadrature of the circle", *pref.*).

The study of quadratures occupied a central place in the development of mathematics during the second half of XVIIth. Following the publication of Cavalieri's *Geometria Indivisibilium* (1635), several mathematicians strove in order to combine the principles of the method of indivisibles with the algebraic formalism issued from Descartes' geometry, in order to derive a more general analytical method able to encompass a large class of curvilinear figures. One of the principal aims of these inquiries was to collect preparatory results in order to solve the squaring of the circle.

Behind these ideas we can still find the conception, ventured also in Van Schooten's *De concinnandis*, that Descartes' algebra of segments might be a fragment of a general method of analysis, whose principles had been secretly developed by the ancients, and whose applications allowed them to solve problems and present them in the synthetic form in which they were mostly transmitted to us. If duly re-discovered, this method of analysis would lead to new and important results, like solving in a systematic way quadratures and rectifications.¹³

However, as pointed out in Panza [2005], a major conceptual difficulty was inherent to the attempts at applying to quadrature problems the fundamental idea of the cartesian model of analysis, namely, the reduction of a geometrical statement to a symbolic expression in the form of an equation. This difficulty concerned the very expression of the result of a quadrature problem.

It is significant, for instance, that one of the most influential early modern treatises on quadratures, the *Arithmetica infinitorum* (1656) of John Wallis, *Savilian professor of geometry* at Oxford for the whole second half of XVIIth century, was still grounded on a traditional approach to the problem: Given a curvilinear figure delimited by the origin and the abscissa $x = z$, the problem of its quadrature consisted for Wallis in the determination of the ratio between the curvilinear figure and the parallelogram, with side z , constructed around the curve.¹⁴

Squaring the curve would thus come down to determine a proportion which we can express in the following form, denoting by A the figure to be squared and by P the

¹³This theme, which appears in Van Schooten's *De concinnandis*, and before him in Viète, can be found in several writers dealing with quadratures. On this concern, Stedall observes: "Torricelli supposed that Cavalieri's methods were those by which the Greeks had found their results, and that by reintroducing them not only would ancient methods be made clear, but new results might be discovered (exactly the hopes Viète had for his 'analytic art')." Stedall [2002], p. 157.

¹⁴Panza [2005], p. 51-52.

parallelogram:

$$A : P = 1 : z$$

If we read this proportion as the equality between two ratios (an interpretation accepted by Wallis), the determination of the fourth proportional z would boil down to the determination of a number expressing the ratio between the curvilinear figure and the parallelogram. Once this ratio is supposed determined, a square or a parallelogram equal in area to the figure A can be also constructed. Therefore, at least in the *Arithmetica infinitorum*, Wallis did not conceive a quadrature as the operation of calculating an area under a closed figure, applicable to any known curve or portion of curve bounded by a system of axes, but held a rather traditional view, which considered a quadrature problem as the determination of a ratio between a curvilinear and a rectilinear figure, and the subsequent construction of a rectilinear figure equivalent to the given curvilinear one.¹⁵

Two major conceptual aspects of Wallis' work can help understand his approach to quadratures. Firstly, he adopted the indivisibilistic point of view, prompted by Cavalieri and Torricelli, which consisted in thinking a plane region as an aggregate of lines, or a solid figure as an aggregate of planes. Secondly, Wallis' way of proceeding in the *Arithmetica infinitorum* relied on an arithmetical approach,¹⁶ in virtue of which he did not formulate the solution of a quadrature problem, including the quadrature of the circle, within the structure of the cartesian algebra of segments, nor did he associate the problem to an equation, but relied on the apparatus of divergent series and numerical interpolations in order to express the ratio between the figure to be squared (in our case, a circle or one of its rational factors) and a polygon circumscribed to it (for instance, a square circumscribed to the given circle) as a ratio of a number to a number.

Such an arithmetical approach to the circle squaring problem, however, presented Wallis with a thorny question. We know that the ratio between a square and its inscribed circle cannot be expressed but throughout a ratio involving a transcendental number. In the classical framework in which Wallis still operated, all the attempts to provision a positive solution to the problem of the quadrature of the circle had therefore to fail: indeed it

¹⁵Panza [2005], p. 53.

¹⁶The primacy of arithmetic over geometry is discussed and justified by Wallis especially in his *Mathesis universalis* (See the *Dedicatio*, in Wallis [1695, 1693, 1699], vol. 1, especially the fourth unnumbered sheet).

is not possible to express the ratio of a square to an inscribed circle in terms of a ratio between known numbers, either rational or surds.

As it has been analyzed in Panza [2005],¹⁷ Wallis circumvented the problem by hypothesizing the existence of a number ϖ , expressing the fourth proportional:

$$Q : C = 1 : \varpi$$

and observed, about the ratio $\frac{1}{\varpi}$: "I am inclined to believe (what from the beginning I suspected) that this ratio we seek is such that it cannot be forced out in numbers according to any method of notation so far accepted, not even by surds, so that it seems necessary to introduce another method of explaining a ratio of this kind, than by true numbers or even by the accepted means of surds".¹⁸ Hence Wallis conjectured that the hypothetical number ϖ could not be expressed in any number so far known, either rational or surds, although it could be calculated to any degree of accuracy and clearly satisfied all the usual rules of arithmetic: it was therefore a number on a par with the other, commonly accepted, numbers.¹⁹

Wallis' treatise offered important insights on the nature of number π , but his arithmetical approach was of little guidance in settling the question posed above with respect to the cartesian stance: is the squaring of the circle air of any of its sectors an impossible problem, namely a problem not expressible by the language of algebra and subject to the method of cartesian analysis?

In this chapter and the following one, I will consider two historical and conceptual developments related to the XVIIIth century debate about the quadrature of the circle and of other conic sections. The first case I will consider one is offered by James Gregory's *Vera Circuli et hyperbolae Quadratura* (1667) and by the subsequent controversy which

¹⁷In particular, chapter 1. See also Stedall [2002], chapter 6)

¹⁸Wallis [2004], p. 161.

¹⁹Although, with hindsight, we can state that Wallis' negative answer is correct, I stress that it remained on the level of a conjecture (Wallis himself spoke of "*conjectura mea*" when referring to it). The point is stressed, among others, by Yoder: "All these techniques for delimiting π , be they geometrically or algebraically garbed, involved repeated processes that were considered to proceed ad infinitum but were truncated at some arbitrary point for evaluation purpose. Of course, today we know that any method for determining π will inevitably involve an appeal to the infinite, because π is transcendental. However, in the XVIIIth century the question was still open ..." (Yoder [1988], p. 138).

opposed Gregory to Christiaan Huygens as one of his main recipients. The second one, that I will discuss in the next chapter, is offered by Leibniz's treatise *De quadratura arithmetica circuli ellipseos et hyperbolae cujus corollarium est trigonometria sine tabulis*, conceived and written in the years 1674-76, which also contains an argument for the impossibility of reducing the squaring of the circle to an algebraic equation. As I will argue, the argument presented by Leibniz maintains important links with Gregory's argument and with the debate between the scottish mathematician and Huygens.

7.2 The controversy between James Gregory and Christiaan Huygens

James Gregory's work *Vera circuli et hyperbolae quadratura* (hereinafter *VCHQ*) was published in Padua in 1667, and reprinted few months later, in Spring 1668, as an appendix to another treatise, *Geometriae pars universalis* (hereinafter *GPU*).²⁰

The first edition, printed in 150 copies, circulated among Gregory's acquaintances, distinguished mathematicians and learned societies. In particular, a copy was promptly sent to Huygens for a critical appraisal.²¹

However, the Dutch mathematician never responded to Gregory; he chose instead to publish, in the form of a letter to the director of the *Journal des Sçavants* a review in which he pointed out what he considered major flaws of Gregory's work.²² As I will expound in the sequel, if proved correct, Huygens' critique would substantially demolish all the original contributions brought by *VCHQ*.

²⁰See Gregory [1667], Gregory [1668b]. See also Gregory [1939], p. 45; Huygens [1888-1950], vol. 6, p. 154. The book underwent a reprint during Gregory's lifetime, as an appendix to *GPU* (published in Spring 1668), and had only one subsequent edition, as part of XVIIth edition of Huygens' *Opera (Christiani Hugenii Zuilichemii, dum viveret Zelhemii toparchae, opuscula posthuma ... 1728)*. Around 1670, Gregory was probably preparing another, enriched edition of his *VCHQ*, but this never saw the light (a mention of this edition can be found in a letter to Collins, from 23 November 1670. See Gregory [1939], p. 118).

²¹Gregory accompanied the copy of his book for Huygens with a letter in which he vehemently requested his opinion ("... mihiq̄ censuram tuam remittas, quam inprimis expecto et vehementer a te peto ..."), dated from 26th September 1667. Indeed, Huygens could be considered an authority in the field: after having studied quadrature problems by means of the centers of gravity, in 1651 (Huygens [1888-1950], vol. XI, p. 273) he published in 1654 a well known work on the quadrature of the circle, namely *De circuli magnitudine inventa* (see Huygens [1888-1950], vol. XII, p. 93). Both works are evoked by Gregory in his accompanying letter.

²²Letter from Huygens to Gallois, 2nd July 1668, in Huygens [1888-1950], vol 6., p. 228.

This severe review probably probably caught Gregory unprepared, since the *VCHQ* had so far received favourable commentaries,²³ and caused an angry polemic between Gregory and Huygens, starting in the month of July 1668 and lasting for few subsequent months. This polemic was mostly consigned to letters addressed for publication in the two major journals of the time: the already quoted *Journal des Sçavants* and the *Philosophical Transactions*.²⁴

This controversy, which saw the involvement of other leading scientific personalities, as John Wallis, Robert Moray, Henry Oldenburg, Lord Brouncker and John Collins, reached an end, at least for which concerns its public dimension, by 1669.²⁵ The following words, written by Robert Moray to Huygens, on 15th February 1669, can be taken as a final and equitable judgement about the the quarrel which opposed the two mathematicians:

²³See, for instance the review appeared on the *Philosophical Transactions of the Royal Society*, in March 1668 (*Philosophical Transactions*, 3, 1668, p. 640-4): " This tract perused by some very able and judicious Mathematicians, and particularly by the Lord Viscount Brouncker, and the Reverend Dr. John Wallis, receiveth the character of being very ingenuously and very Mathematically written and well worthy the study of men addicted to that Science. . ." (Wallis [1668a], p. 641).

²⁴The first reply by Gregory dates from 23rd of July 1668 (Huygens [1888-1950], vol. 6, p. 240). Soon later, in the introduction to his book *Exercitationes Geometricae* (hereinafter *EG*), which was probably terminated in midsummer 1668 and published soon after, Gregory returned, this time with particularly harsh tones, on Huygens' criticism. Huygens ignored the attack, though, but replied to Gregory's letter from July with another critical paper published in november 1668 on the *Journal des Sçavants* (Huygens [1888-1950], vol. 6, p. 272-276). Gregory's answer, written in the form of a letter to Henry Oldenburg, on 25th December 1668, was eventually printed in the *Philosophical Transactions* on 15th February 1669 (Huygens [1888-1950], vol.6, p. 306-311). Subsequently, Huygens planned a response to Gregory's *Exercitationes*, but never published it (Huygens [1888-1950], vol. 6, p. 321). The main pieces of the controversy are also reproduced in the volume *Christiani Hugenii Zulichemii, Dum viveret Zelemii Toparchae, Opera Varia. Volumen primum. Lugduni Batavorum, 1724*. Under the title *De circuli et hyperbolae quadratura Controversia* the following pieces can be found: *Vera Circuli et hyperbolae Quadratura auctore Jacobo Gregorio* (p. 405-462); *Hugenii Observationes in librum Jacobi Gregorii, De Vera Circuli et hyperbolae quadratura* (pp. 463-466); *Domini Gregorii Responsum ad animadversiones Domini Hugenii, in ejus librum, De Vera Circuli et hyperbolae quadratura* (p. 466-471); *Excerpta ex literis Domini Hugenii de responso ...* (p. 472-474); *Excerpta ex epistola D. Jacobi Gregorii, impressa in vindicationem ...* (p. 476 - 482). See also Dijksterhuis [1939], p. 485.

²⁵After February 1669, echoes of the dispute continue to be found sporadically in private communications, both by Huygens (see for instance, 30 march 1669, p. 397) and Gregory (see for instance, the letter sent to Collins from 6th January 1670, in Gregory [1939], p. 75-77). One of the main reasons which caused the controversy to end concerned the political undertones which accompanied it. Gregory's responses were published on the *Transactions of the Royal Society*, to which Huygens belonged as the most distinguished foreign member. Huygens' influential opinion and Gregory's lack of care for public relations contributed to isolate Gregory within the Royal Society, of which he was also a member. Thus, in the arc of few months, Gregory managed to lose the support of the intellectual world of London, and in particular of Robert Moray, an important political man, and of John Wallis, who had backed him firstly, at least mathematically speaking (See Malet [1989], p. 36). Nevertheless, Hofmann remarks a smoothening of the tension, at least on Huygens' side, towards the year 1671: for instance, Huygens proposed Gregory's name as a future member of the *Académie des Sciences*, and even sent him, as a present, a copy of his *Horologium Oscillatorium* (AIII, 1, p. LV.).

Il n'est pas necessaire que j'entre dans la matiere dont il y a question entre vous. Mais permettez moy de vous dire franchement ce que je pense de laigreur qui en est produite. Monsieur Gregoire est à la verité bien sçavant dans la Mathématique mais le feu de sa jeunesse a besoin d'adoucissement. Je ne scaurois approuver son procedé envers vous quelque iustification qu'il en presente, il a failly contre les regles de la morale en se laissant emporter comme il a fait. Je le blasme donc fort de ce qu'il vous a traitte d'une maniere si rude. Mais d'autre part il ne faut pas que Je vous cele, que de la façon qu'il s'est represente vostre procedé en son endroit, il auroit besoin d'une retenue plus grande qu'il n'a pour ne s'en piquer en quelque façon. Non pas tant de ce qu'au lieu de luy représenter par lettre ce que vous auriez trouvé à redire à ce qu'il avoit publié, comme il avoit désiré, vous l'avez fait imprimer sans luy écrire, comme de ce que d'abord vous le traitez, à ce qu'il luy semble, nettement de plagiaire. Je ne veux pas examiner s'il sy est mépris ou non. Mais Je vous diray que Je scay plusieurs instances ou deux personnes ont inventé une mesme chose sans que lun ait rien pris de l'autre (...) de sorte qu'en telles rencontres on doit se bien garder de traiter quelqu'un de plagiaire sans le pouvoir prouver formellement, veu qu'à mon avis il ne se peut rien dire de plus cuisant à un honeste homme.²⁶

This judgement bore, to quote Moray again, on the "circumstance et maniere d'agir" rather than on the matter of the dispute.²⁷

On the other hand, if we turn to the issues at stake in the controversy, we can note that the structure of the latter escapes the usual argumentative scheme of most of XVIth and XVIIth century disputes over the quadrature of the circle. As the cases of Longomontanus' or Van Roomen's illustrate, early modern controversies generally raised after an alleged solution to the quadrature was proposed; the flawed solution was then followed by negative responses by one or several expert mathematicians, pointing to the errors in the alleged quadrature.²⁸

²⁶Huygens [1888-1950], vol. 6, p. 370.

²⁷See the letter from Meray to Huygens, of 26th April 1669: Huygens [1888-1950], vol. 6, p. 423.

²⁸Many examples from XVIIIth century can be taken from Jacob [2005]: the exchanges between countless "circle-squarers" and the mathematicians of the *Académie des Sciences*, charged to judge, and eventually refuted all faulty attempts, obeyed to the same dynamics.

In the case I am here examining, on the contrary, Gregory did not propose a constructive solution to the problem, but argued that it was impossible to express, by any finite succession of ‘analytic’ operations, that is, operations we would call today ‘algebraic’ (addition, subtraction, multiplication division and extraction of roots of k order, for $k \in \mathbb{N}$) starting from polygonal areas of rational measure, the measure of any Portion of a Circle, Ellipse or Hyperbola.

The problem considered by Gregory is more general than the traditional circle-squaring problem, since it concerned the quadrability of an arbitrary sector of a central conic. Gregory also believed that the impossibility of solving this problem analytically entailed the impossibility of solving analytically the quadrature of the whole circle, that is, the quadrature problem in the traditional sense.

The controversy which opposed James Gregory and Christiaan Huygens developed around three main points of divergence.²⁹ Firstly, Huygens addressed to Gregory an accusation of plagiarism, as he recognized two proposition of *VCHQ* (namely the XX and the XXI) supposedly similar to a couple of propositions formulated in his own work *De Circuli magnitudine inventa* (1654).³⁰ The second point of divergence regards another accusation of plagiarism moved by Huygens, concerning, in this case, a method for calculating logarithms based on the quadrature of the hyperbola, that Gregory had presented in *VCHQ* as original. Huygens objected that Gregory’s method had been already known to him and communicated to the French *Académie des Sciences* and to the *Royal Society*, before the publication of the *VCHQ*.³¹

The third group of objections advanced by Huygens regarded, instead, the soundness of Gregory’s impossibility theorem and the validity of deducing from it the impossibility of an analytical quadrature of the whole circle (this is proposition XI in Gregory’s treatise and in its subsequent corollary). Eventually, as I will discuss later, Huygens denied both the validity of Gregory’s proofs and expressed doubts as to the truth of the impossibility theorems proposed.

Only this point of divergence will interest my narration. In the following sections, I will firstly describe the strategy pursued by Gregory in order to formulate an impossibility claim in the form of a theorem, and I will study the proof he eventually supplemented.

²⁹Dijksterhuis [1939], p. 483.

³⁰Huygens [1888-1950], vol. 6, p. 231.

³¹Huygens [1888-1950], vol. 6, p. 231.

My focus will deal with the attempts, pursued by Gregory, in order to merge the techniques for approximating the circle by polygonal sequences with the structure of cartesian analysis: such attempts, as Dehn and Hellinger resumed it in their survey paper on Gregory's mathematical achievement, led Gregory to transform the archimedean geometric method of approximation into "an algebraic one (...) a sort of calculus", and on this basis to formulate his impossibility claim.³²

My second line of interest will concern the role played by impossibility results, like the ones alleged proved in *VCHQ*, in Gregory's view about the architecture of mathematics and, more particularly, in his view about the delimitations of the boundaries of geometry. Indeed, Gregory expressed the conviction that certain impossibility results might act as a source for legitimating the enrichment of geometry with new entities and operations. I will argue that this view follows two conceptual threads which originated with Descartes' reflection on simplicity in problem solving, on one hand, and with Wallis' considerations about the role of impossibility proofs in mathematics, mostly consigned to his *Arithmetica Infinitorum* (1656), on the other.

7.3 Analyzing the quadrature of the circle

7.3.1 The aims of analysis

The body of the short treatise *VCHQ* is organized in a rather traditional fashion: after the preface, written in the form of a dedicatory letter to a friend, Gregory lists ten definitions and two postulates (*petitiones*), followed by the thirty-five propositions (divided into theorems, problems and scholia) which compose the whole treatise.

My survey of *VCHQ* will be limited to the first eleven propositions (plus the definitions and postulates), which occupy less than half of the whole treatise, but can be seen as forming a unitary body: on one hand, they are somehow preparatory for Gregory's impossibility argument; on the other, the saliency of these propositions is recognized by Gregory himself, who admitted their theoretical import in contrast with the remaining ones, added "for facilitating the practice".³³

³²Gregory [1939], p. 469.

³³This point was made, as a clarificatory remark, from Gregory to Wallis, on 26th March 1668. See Gregory [1939], p. 49. By the expression "facilitating the practice", Gregory might have referred to the new procedures for the approximate measure of the area of the circle and the hyperbola and for the calculation of logarithms, exposed in his treatise, especially in propositions XXIX-XXXIV.

Cartesian geometry, and in particular Descartes' method of analysis are evoked at the outset of the *VCHQ*, where we read, in a prefatory letter to the "friendly reader", the following words:

Mecum alinquando cogitabam, amice lector, num analytica cum suis quinque operationibus esset sufficiens, et generalis methodus investigandi omnes quantitatum proportionales, ut in initio suae Geometriae affirmare videtur Cartesius; si enim ita esset, possibile foret ejus ope toties decantatam circuli quadraturam exhibere: cumque hac mente revolverem, facile percepi ex hactenus repertis circuli proprietatibus nullam posse analysin institui tali structurae inservientem: deinde mihi alias quaerenti incidit in mentem huius secunda, prima enim in circulo vulgo est cognita: ex hisce percepi seriem polygonorum convergentem, cujus terminatio est circuli sector, ubi statim vidi aliquod analysios vestigium. Deinde serierum convergentium naturis non solum in facilioribus quibusdam casibus, sed etiam in genere consideratis, et praedictis circuli proprietatibus ad ellipsim et hyperbolam nullo negotio reductis, infallibilis mihi videbatur omnium sectionum conicarum quadratura . . .³⁴

This dense passage requires some clarifications. Gregory starts his letter resuming the motivations and rationale of his work: Gregory considers the problem of the quadrature of the circle as a test-case in order to question the generality of the cartesian transconfigurational analysis, and immediately concludes that the structure of the circle-squaring problem could not be unfolded by the tools of Descartes' analysis.

For a reader of Descartes, this is certainly not so stunning, since the latter had postulated the non-comparability between straight and curved lines within geometry. However it cannot be established whether Gregory had a first-hand knowledge of *La Géométrie* during his mathematical studies in Padua; it is probable, on the contrary, that he had

³⁴"I have been wondering sometimes, my friendly reader, whether Analysis with its five operations was a sufficient and general method to investigate all proportions between quantities, as Descartes seemed to affirm in the beginning of his geometry; if it was so, it would be possible, by its aid, to exhibit the so illustrious quadrature of the circle: thinking with this idea in mind, I could easily perceive, from the properties of the circle so far discovered, that no analysis could be construed so as to serve such a structure [namely, the structure of the problem]: then it came to my mind a second kind of analysis, while I was searching for others (the first, concerning the circle, was indeed known to the laymen). Through these I understood the convergent series of polygons, whose limit (*terminatio*) is a sector of the circle, where, immediately, I saw some trace of analysis. Then, considered the natures of the convergent series not only in the easier cases, but also in general, and reduced the properties predicted for the circle to the ellipsis and the hyperbola with little trouble, the quadrature of every conic sections seemed infallible to me" (*VCHQ*, p. 4).

had only an indirect acquaintance with Descartes' geometry, during his stay in Italy as a mathematics trainee, through the work and teaching of Italian analysts, like Carlo Renaldini (1615-1698).³⁵

Moreover, by 1667 Descartes' conviction about the impossibility of solving the circle-squaring problem in an exact way had been deeply questioned among mathematicians,³⁶ so that, in this historical setting the question, raised by Gregory, whether the "Analysis with its five operations" was a sufficient and general method to investigate the quadrature of the circle, was a genuine one.

At any rate, after having correctly pointed out the inadequacy of known methods in order to study the circle-squaring problem, Gregory invokes, in the same preface (see the above excerpt) a "second kind of analysis", more apt to study the quadrature of the circle and the other conic sections (at the sequel will make it clear, Gregory will discuss only the central conic sections). The structure of such "second kind analysis" can be tentatively reconstructed both from the elliptic account presented in the preface and from the content of the *Vera circuli et hyperbolae quadratura*.³⁷

To provide a clearer account, I will distinguish two steps constitutive of it. The first one consisted in the elaboration of a geometric approximation method, detailed in the opening lines of *VCHQ*, in order to compute the area of the circle by the successive construction of inscribed and circumscribed polygons. The second step consists in extrapolating an infinite double sequence from the previous geometric process. Gregory

³⁵According to Hofmann [2008], p. 70, Gregory was not yet conversant with cartesian geometry by the late sixties. I note that Descartes' latin edition of the geometry is mentioned in another treatise by Gregory, the *Geometriae Pars Universalis*, published in 1668 (in particular, proposition 70, p. 132), together with the work of Carlo Renaldini, *De resolutione atque compositione mathematica libri duo* (Patauii: typis ac impensis heredum Pauli Frambotti, 1668). The latter, in particular, was teaching in Padua around the same period in which Gregory was there a student. Thus Renaldini was a likely source of Gregory's early knowledge about cartesian geometry.

³⁶*Cf.* ch. 6, sec. 6.3.

³⁷Gregory contrasts his own method with an analytical method for treating the circle-squaring problem "known to the laymen" ("*vulgo . . . cognita*"), although he is not explicit about his sources. He might be envisaging known archimedean-like procedures for approximating the area of the circle: Viète's approximate procedure, contained in *Variorum de rebus mathematicis* (published in 1593 and subsequently in *Francisci Vietae Opera mathematica*, edited by F. van Schooten and published in 1646 - *Francisci Vietae Opera mathematica in unum volumen congesta ac recognita . . .*, 1646, Ex Officina Bonaventurae et Abrahami Elzeviriorum, Leiden) could be one of these. Evidence, though tenuous, for a connection between Gregory's techniques and Viète's achievement is offered by Dehn and Hellinger who note that the formula for area given by Viète (in modern notation: $\frac{2}{\pi} = \cos\frac{\pi}{4}\cos\frac{\pi}{8}\cos\frac{\pi}{16}\dots$) allows one to derive one of the recursive formulas given by Gregory, specifically for the case of the semicircle (Gregory [1939], p. 469).

defined this sequence recursively, by specifying its law of formation, independently from the original geometric model which originated it (compare df. 9, quoted below).

The starting point of Gregory's analysis was the traditional archimedean method for the measurement of the circumference. However, Gregory introduced an important novelty with respect to the tradition, as he conceived only one approximation procedure applicable to any central conic section (i.e. a circle, an ellipse or an hyperbola, showed in fig. 7.3.1 and 7.3.1).³⁸

Gregory's construction is presented in the first proportions of *VCHQ* (p. 11) can be thus summarized according to the following scheme:

1. Let \widehat{APB} be the given sector with center A . Trace the tangents PF and BF , and join points F and A so as to yield points Q , intersection between segments FA and PB , and point I , intersection between FA and the arc delimiting the sector. In the case of a circle or an ellipse, this construction yields a triangle ABP called by Gregory "inscribed" in the sector and a trapezium $ABFP$ circumscribed to it. The same construction can be applied to an hyperbola (fig. 3.2). In this case, though, the triangle will be circumscribed and the trapezium inscribed to the figure.³⁹
2. The same protocol can be applied to sectors \widehat{BAI} and \widehat{IAP} , so as to obtain a second inscribed (resp. circumscribed, in the case of the hyperbola) polygon, namely $ABIP$, and a new circumscribed (resp. inscribed) pentagon $ABDLP$ (or viceversa, in the case of the hyperbola). Moreover, if points D and L are joined with the center A , a couple of new points E and O is obtained on the perimeter of the sector, and the hexagon $ABEIO P$ can be thus traced. Similarly, by tracing a new couple

³⁸The concept of 'center' is defined, for the hyperbola and the ellipse, in Apollonius' *Conica*. For the ellipse, the centre is the midpoint of the principa diamter. For the case of the hyperbola, the center is defined as the midpoint of the segment cut on the principal diameter by the intersection points with the hyperbola and the opposite branch (Cf. Hogendijk [1991], p. 9-10). For the case of the circle, the concept of center is defined in the *Elements*, df. 15 and 16: "A circle is a plane figure contained by one line such that all the straight lines falling upon it from one point among those lying within the figure are equal to one another; and the point is called the centre of the circle". Gregory's general method for the squaring of the central conic sections fits surprisingly with Newton's results obtained in the 1666 treatise *De Methodis*. Newton's achievement concerned the non-algebraic quadrability of a large class of what we call today 'elliptic functions', and may stand as the first step of the modern theory of elliptic functions. However it is excluded, I think, that Gregory could have consulted, in 1667, Newton's treatise of 1666. Hence the two results are independent and also very different, although consistent one with the other. Therefore Gregory's contribution in *VCHQ* can be taken as a parallel starting point of the theory of elliptic functions as Dehn and Hellinger also seem to suggest (Dehn and Hellinger [1943], p. 156).

³⁹*VCHQ*, p. 9

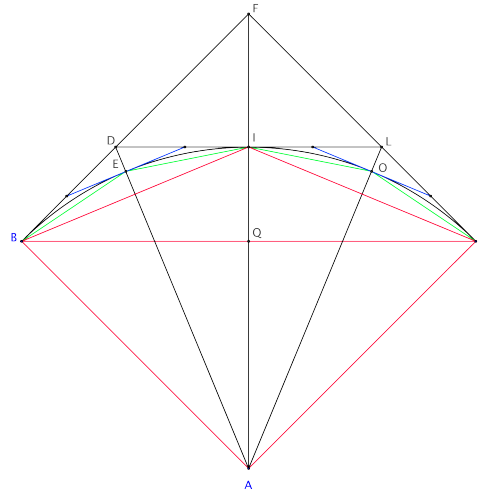

Figure 7.3.1: The quadrature of a circular sector.

of tangents in E and O , a new circumscribed heptagon can be drawn, contained in $ABDLP$, and so on.⁴⁰

Once introduced this protocol for constructing two successions of inscribed and circumscribed polygons to a given sector, Gregory managed to represent them by means of a pair of infinite "convergent"⁴¹ sequences $\{I_n\}$ and $\{C_n\}$, recursively defined as follows:

$$\begin{cases} I_{n+1} = \sqrt{C_n I_n} \\ C_{n+1} = \frac{2C_n I_n}{I_n + \sqrt{C_n I_n}} \end{cases}$$

In this way, through the reduction of a geometric recursive process to a two-term recursion, Gregory also managed to reduce the geometric problem of squaring the sector of a conic to the algebraic problem of computing the common limit Φ (the "terminatio", in Gregory's own words, which expresses the sector itself, or its area) of the sequences $\{I_n\}$ and $\{C_n\}$ associated to the polygonal construction given above.

⁴⁰ *VCHQ*, p. 12, 13.

⁴¹As I will explain later, the term "convergent" is employed by Gregory in an essentially different way than in its modern usage, but slightly closer to our notion of convergent in the sense of Cauchy.

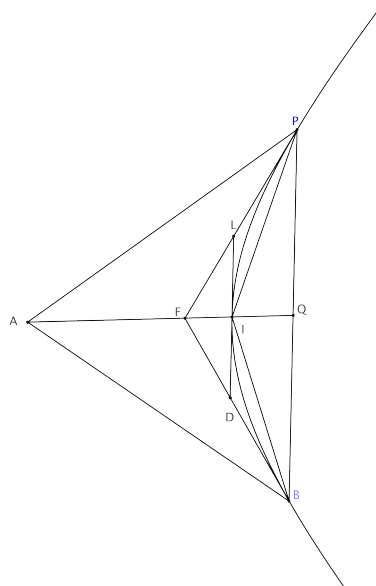

Figure 7.3.2: The quadrature of a hyperbolic sector.

In my reconstruction, this step concludes Gregory's analysis of both the circle (or ellipse) and the hyperbola-squaring problems. As Gregory admitted in the preface of *VCHQ*, he was probably confident, in a first stance, that the limit Φ could be found by means of analytical techniques, involving only the five arithmetical operations introduced by Descartes at the outset of *La Géométrie* (in other words, Gregory might think about the possibility of constructing the magnitude Φ as a root of an algebraic equation) and tried to work out a general method in order to express analytically the limit of a double convergent sequence (some examples discussed by Gregory are illustrated below), which however did not lead to any result for the special case of the sequences approaching Φ .⁴²

Having fallen short in his attempt to find an algebraic, or analytical quadrature, Gregory turned to the core result presented in *VCHQ*, that we may paraphrase as such: the recursive sequences extracted from the geometric successions of inscribed and circumscribed

⁴²As Gregory commented: "deinde serierum convergentium naturis non solum in facilioribus quibusdam casibus, sed etiam in genere consideratis, et praedictis circuli proprietatibus ad ellipsim et hyperbolam nullo negotio reductis, infallibilis mihi videbatur omnium sectionum conicarum quadratura: dum autem me illuc converti ut polygonorum seriem terminarem, insuperabilem difficultatem in ejus terminationem inveniendam post omnes artis et aleae conatus deprehendi" (*VCHQ*, p. 4). In my translation: "Then, considered the natures of the convergent series not only in the easier cases, but also in general, and reduced, without difficulty, the properties predicted of the circle to the ellipsis and the hyperbola, the quadrature of every conic sections seemed infallible to me. However, while I turned myself to terminate the convergent series of polygons, I stumbled on an unsurpassable difficulty in finding its termination, after having tried all methods and chances".

polygons fail to converge to a limit computable by analytic (algebraic) operations.⁴³

Eventually, Gregory acknowledged that this negative outcome of analysis could be stated and proved by a mathematical argument.⁴⁴ Although the idea that the structure of the analytical reasoning could lead to impossibility results had already surfaced in the considerations of early modern mathematicians,⁴⁵ Gregory showed an original insight not only by formulating an impossibility claim in the form of a mathematical theorem, but also by suggesting that other useful and highly admirable results would enrich mathematics, provided one included, among the proper tasks of the mathematician, the systematic search and proof of likewise impossibility results. In brief, this would open a new realm of research, that includes:

... demonstratio, quod mesolabium non posse perfici ope regulae et circini, item quod non semper et quando aequationes affectae possunt reduci ad puras, item quod necessaria fit ad minimum talis generis curva ad mechanicam talium aequationum resolutionem, cum talibus innumeris, quae a praesantioribus geometris impossibilia esse deprehenduntur ex analysi, et a rudioribus quotidie et frustra quaeruntur.⁴⁶

Gregory delineates a veritable program by singling out some of the central mathematical issues that may constitute the new territory of research: firstly, to prove the impossibility of solving by ruler and compass problems solvable through the 'mesolabe', namely solid or higher problems (I recall that the mesolabe is a device elaborated for solving the problem

⁴³In Gregory's words: "dico sectorem circuli, ellipseos vel hyperbolae *ABIP*, non esse compositum analyticè a triangulo *ABP* et trapezio *ABFP*." *VCHQ*, p. 25. "I claim that the sector of the circle, ellipse or hyperbola *ABIP* is not composed analytically from the triangle *ABP* and the trapezoid *ABFP*". See also Dijksterhuis [1939] in Gregory [1939], p. 482.

⁴⁴*VCHQ*, p. 4. In my translation: "... judging with my mind that it was a task of analysis, as well as of common algebra (*animo revolvens analysios esset sicut algebrae communis*), not merely to solve problems, but also to prove their impossibility (if there is the necessity); and since I have found unsayable difficulties in the first, I turned to the second, which was certainly obtained beyond expectations; indeed, I disclose the true and legitimate (*veram et legitimam*) quadrature in its kind of proportions not of the sole circle, which I have proposed to myself from the beginning, but of the whole conic sections, and an integer kind of proportion unknown before to the domain of geometry (*et integram proportionis speciem ante incognitam orbi Geometrico*)".

⁴⁵We find traces in the consideration of other authors, like Descartes. See our discussion in chapter 4.

⁴⁶*VCHQ*, p. 5-6: "... the proof that the mesolabium cannot be superseded by ruler and compass, that composed equations cannot be always reduced to pure ones, and in which cases they can, and which curve of minimal kind is necessary for the mechanical solution of given equations, with countless similar, which are cognized as impossible by the most expert geometers on the ground of analysis, and are daily searched in vain by the less skilled ones". See also the exposition of Dehn and Hellinger, in Gregory [1939], p. 474-475.

of inserting two or more mean proportionals between two given segments: *cf.* chapter 3 of the present study, sec. 3.2), secondly, to prove in which case a given (algebraic) equation cannot be decomposed into factors, and thirdly to assess the curves of minimal kind necessary for the construction of a given problem.

We recognize that the results mentioned above can be all brought back to insights originated in Descartes' *Géométrie* (*cf.* chapter 4 of this study): hence we can venture the hypothesis that Descartes' geometry inspired the main guidelines of Gregory's program concerning the study of impossibilities in mathematics; at the same time, as I shall discuss below, the method of analysis employed in *La Géométrie* constituted a fundamental tool in order to study and prove impossibility results (as Gregory remarks, in fact, impossibility results are discovered "by the most expert geometers on the ground of analysis").

With hindsight, Dehn and Hellinger recognize that: "a modern mathematician will highly admire Gregory's daring attempt of a 'proof of impossibility' even if Gregory could not attain his aim. He will consider it a first step into a new group of mathematical questions which became extremely important in the 19th century".⁴⁷ However, modern (namely, late XIXth century) impossibility results are not only technically more correct than the arguments offered by Gregory (to be examined in what follows), but they are also proved by means of concepts extraneous to the fragment of mathematics we are considering: modern impossibility theorems were in fact recognized as proper mathematical achievements only at the price of a deep conceptual shift in mathematics, which occurred between the end of XIXth century and XXth century.⁴⁸ It is therefore important to inquire to what extent the impossibility claims advanced by Gregory, together with the arguments offered for their proofs, differed in their meaning, scope and aims from the modern (XIXth century onwards) ones.

7.3.2 Introducing convergent sequences

In this section, I will explore in more detail how Gregory accomplished the reduction from the geometric quadrature problem to its algebraic counterpart, which led to the crucial impossibility result expressed in proposition XI of *VCHQ*.

⁴⁷Dehn and Hellinger [1943], p. 160.

⁴⁸Cf. the *Introduction* of this study.

The group of ten definitions which opens Gregory's treatise *VCHQ* may be divided in two parts: whereas the first four definitions concern geometric figures in the plane, and offer an adequate terminology in order to denote the specific configurations of polygons which will be considered during the treatise and their relations in the construction of the sequences (see fig. 7.3.1 and fig. 7.3.1), the content of definition 5 and of the following ones is radically different, since they concern operations between abstract quantities.

Thus, Gregory introduces in df. 5 a general notion of "composition", which holds between quantities considered both as numbers, i.e. arithmetical entities, and magnitudes, ie, geometrical entities, probably on the ground of the correspondence between arithmetical operations and geometrical constructions set up in Descartes' geometry. In Gregory's own words:

quantitatem dicimus a quantitibus esse compositam, cum a quantitatibus additione, subductione, multiplicatione, divisione, radicum extractione, vel quacumque alia imaginabili operatione, sit alia quantitas.⁴⁹

Definition 6, on the other hand, specifies that when we consider only addition, subtraction, multiplication division and the extraction of roots ('*radicum extractio*') the resulting quantities are composed analytically:

Quando quantitas componitur ex quantitatibus additione, subductione, multiplicatione, divisione, radicum extractione; dicimus illam componi analytice.⁵⁰

I surmise that Gregory groups, in this definition, the very operations evoked at the beginning of the *VCHQ*, namely the 'five arithmetical operations' constitutive of the determinative algebra deployed by Descartes at the beginning of *La Géométrie*. Thus

⁴⁹"We say that a quantity is composed by quantities, when another quantity derives from the addition, subtraction, multiplication, division, extraction of roots, or from whatever other imaginable operation of these quantities". *VCHQ*, def. 5, p. 9. I note that the definition of composition proposed here by Gregory resembles the definition of function encountered in later works by Euler, Bernoulli or Lagrange, for instance. It is sufficient to compare it with Euler's proposed one in the *Introductio in analysi infinitorum* (1748): "A function of a variable quantity is an analytical expression composed in any way whatever of this variable quantity and numbers or constant quantities" or with a similar definition to be found in Bernoulli's article *Remarques sur ce qu'on a donné jusqu'ici de solutions des problèmes sur les isoperimètres* (1718): "I call a function of a variable quantity, a quantity composed in whatever way of that variable quantity and constants" (see Ferraro and Panza [2011], p. 105, footnote 17, where Gregory is explicitly mentioned in connection with Euler and Bernoulli).

⁵⁰"When a quantity is composed from the addition, subtraction, multiplication division and extraction of roots; we say that it is composed analytically". *VCHQ*, def. 6, p. 9.

'*radicum extractione*' plausibly refers to the n -th-root extraction (for n natural number), of a quantity.⁵¹

In df. 7, then, Gregory offers a genetic definition of "analytical" quantities, as those quantities obtained from given commensurable ones through the application of finite combination of analytical operations:

Quando quantitates a quantitatibus inter se commensurabilibus analytice componi possint, dicimus illas esse inter se analyticas.⁵²

Df. 7 states that if a and b are given commensurable quantities, their sum is a quantity analytical with them, and so are their difference, product and quotient. Moreover, if a is a quantity, $\sqrt[n]{a}$ is analytical with a as well (for n natural number). Since Gregory considered any finite combination of analytical operations an analytical operation in its turn, it is immediate to conclude that any quantity obtained from given commensurable quantities a and b by any finite combination of the five analytical operations results into an analytical quantity. According to this definition, therefore, analytical quantities include both commensurable and incommensurable ones, the latter obtained by the operation of root extraction applied to commensurables.⁵³

On this ground, an adequate relation of equivalence can be defined, for instance in the following terms:

a quantity a is equivalent to b if a is analytical with b .

Since combinations of analytical operations are also analytical operations, this relation is transitive, whereas symmetry and reflexivity are obvious by definition. Therefore, we can introduce a partition within the set of couples of quantities, and define

⁵¹Descartes [1897-1913], vol. 6, p. 370.

⁵²"When quantities can be composed analytically from quantities commensurable among themselves, we say that they are analytical among them" (*VCHQ*, p. 9).

⁵³The quantities denoted as "analytical" in *VCHQ* can be taken to correspond, at first sight, to the field of real algebraic magnitudes. It must be noted, however, that this reading is in conflict with some of Gregory's assertions made in *VCHQ*. Contrary to what Gregory claimed, for instance, in *VCHQ* (p. 10) real algebraic magnitudes are not closed under algebraic operations, since the roots of a negative quantity do not belong to them. In order to give a mathematically coherent reading of Gregory's idea of analytical quantities, we should consider complex algebraic quantities as analytical too: only in the field of complex algebraic numbers, in fact, the extraction of roots becomes an internal operation. This is not the only point which speaks against a plain identity between 'algebraic' and 'analytic': I will consider a second objection later, with respect to a remark advanced in Scriba [1983], p. 283.

two classes $E_c = \{D/\text{analytical}(D, C)\}$, where C and D are quantities, and $F_c = \{A/\text{non-analytical}(A, C)\}$, where A and C are also quantities.⁵⁴

This result is not explicit in Gregory's narration, but corresponds to what we find stated in a couple of postulates (*petitiones*) following the list of definitions:

Petimus quantitates, a quantitatibus datis inter se analyticis analyticè compositas, esse inter se & cum quantitatibus datis analyticas.⁵⁵

Item quantitates, quae a quantitatibus datis inter se analyticis non possunt analyticè componi, non esse cum quantitatibus datis analyticas.⁵⁶

Despite their unclear axiomatic status,⁵⁷ we note that, through the formulation of these postulates, Gregory strove to characterize analytical quantities by the fact of being closed under a specific collection of operations, namely analytic, or algebraic ones.⁵⁸ This constitutes a fundamental insight laying the grounds for Gregory's impossibility argument, as I will argue later.

The second fundamental insight brought about by Gregory is represented by the definition of 'convergent sequence', presented in *VCHQ*, df. 9, p. 10. In order to understand its meaning and import, I will briefly go back to the polygonal approximation method devised by Gregory and illustrated in figures 7.3.1, and 7.3.1.

Since the construction protocol which generates the succession of inscribed and circumscribed polygons can be indefinitely iterated, two infinite sequences $\{I_n\}$ and $\{C_n\}$ of

⁵⁴See Scriba [1957], p. 14. An analogy can be made with proposition 12 and 13 of Euclid's book X, where the relation "being commensurable" is proved to be an equivalent relation and, on the strength of this result, the domain of quantities can be partitioned into two disjoint sets (See Vitrac's commentary in Euclid [1990], vol. 3, p. 135). However, unlike Euclid did in the *Elements*, Gregory did not prove theorems, but formulated postulates in order to characterize the analytical quantities, as I will explain below.

⁵⁵"We demand that quantities composed analytically from given analytical quantities one with respect to the other, are analytical between them and respect to the given quantities". *VCHQ*, p. 10.

⁵⁶"Similarly, quantities which cannot be composed analytically from given quantities analytical one with respect to the other, are not analytical with the given quantities". *VCHQ*, p. 10.

⁵⁷The characterization of both statements as postulates can be questioned too: they both appear more similar to theorems which require to be proved. It is possible that Gregory perceived this problem, though. As he confessed in a letter to Wallis from October 1668, he judged his two "petitions" too obscure, although he mitigated his judgement considering that the principles of geometry were difficult to set, as the example of Euclid's first Book of the *Elements* reveals to us (in Gregory [1939], p. 52-53).

⁵⁸In the Cambridge Dictionary of philosophy, 'Closure' is so defined: 'A set of objects, O , is said to exhibit closure or to be closed under a given operation, R , provided that for every object, x , if x is a member of O and x is R -related to any object y , then y is a member of O '. See Audi [1999].

inscribed and circumscribed polygons can be constructed, starting from the initial triangle $ABP = I_0$ and from the initial trapezium $ABFP = C_0$. It is clear, from the geometric model, that both sequences converge to the sector \widehat{APB} , that is, they approximate it closer and closer as the number n increases.⁵⁹

It is also clear, from the previous fact, that as n increases, polygons I_n and C_n approach each other more and more. In definition 9, Gregory tried to capture this intuitive geometric fact by the concept of "convergent sequence" (*series convergens*, in the original) defined in the following terms:

Sint duae quantitates A et B, quibus componantur duae aliae quantitates C et D, quarum differentia sit minor differentia quantitatum A et B, et eodem modo quo C componitur a quantitatibus A et B, componatur E a quantitatibus C et D, et eodem modo quo D componatur a quantitatibus A et B, componatur F a quantitatibus C et D, et eodem modo quo E componitur a quantitatibus C et D, vel C a quantitatibus A et B, componatur G a quantitatibus E F, et eodem modo quo F componitur a quantitatibus C D, vel D a quantitatibus A B, componatur H a quantitatibus E F, atque ita continuetur series: appello hanc seriem, seriem convergentem.⁶⁰

The somewhat verbose content of this definition can be resumed as such:

Definition. By a "convergent sequence" (*series convergens*) Gregory actually refers to a couple of successions $\{a_n\}_{0 \leq n < \infty}$ and $\{b_n\}_{0 \leq n < \infty}$ obeying to these conditions:

$$\forall n, \begin{cases} a_{n+1} = S(a_n, b_n) \\ b_{n+1} = S'(a_n, b_n) \end{cases} \quad (7.3.1)$$

⁵⁹Whiteside chose to represent this process according to the formalism of limits: $\lim_{n \rightarrow \infty} \{I_n\} = \lim_{n \rightarrow \infty} \{C_n\} = \widehat{APB}$. This representation is formally correct, and complies with a heuristic definition of limit: in the space of geometrical quantities, the difference between the sector \widehat{APB} and an inscribed polygon I_n , and the difference between a circumscribed polygons C_n can be taken arbitrarily small as n increases.

⁶⁰"Let A and B be two quantities, from which two other quantities C and D are composed, whose difference is less than the difference of quantities A and B, and in the same way in which C is composed from quantities A and B, let E be composed from quantities C and D, and in the same way in which D is composed from quantities A and B, let F be composed from quantities C and D, and in the same way in which E is composed from quantities C and D, or C from A and B, let G be composed from quantities E and F, and in the same way in which F is composed from quantities C and D, or D from quantities A and B, let H be composed from quantities E and F, and thus let the sequence be continued: I call this sequence, convergent sequence". *VCHQ*, definition 9. p. 10.

$$\forall n \mid b_{n+1} - a_{n+1} \mid < \mid b_n - a_n \mid \quad (7.3.2)$$

In the rest of the chapter, I will use, following Gregory, the expression ‘convergent sequence’, in the singular, to denote a couple of successions which obey to property 7.3.1 and 7.3.2, and the expression ‘convergent term’ to denote the couple (a_k, b_k) .⁶¹

Returning to the above definition, let us observe that through condition 7.3.1 Gregory defines convergent sequences recursively: the term a_{k+1} of the succession $\{a_n\}$ is obtained by applying composition S to the couple (a_k, b_k) , and the term b_{k+1} of succession $\{b_n\}$ is obtained by applying another compositions S' to the same couple (a_k, b_k) . Condition 7.3.2, on the other hand, only states that the difference between the second couple is smaller than the difference between the first couple.⁶²

I remark that no concept of limit is explicitly involved in Gregory’s definition of convergent sequence. This point is relevant, since it allows us to advance the hypothesis that Gregory intended to define a notion of ‘convergence’ for the successions a_n and b_n in terms of the following property: as n grows, the differences between b_n and a_n become smaller and smaller. Convergence in this sense should not be confused with the property of approaching a given limit-quantity as n grows: with hindsight, we may here ascribe to Gregory a partial attempt to capture a property analogous to that of being Cauchy sequential.⁶³

⁶¹As the subsequent discussion will clarify, the term ‘convergent’ is employed here in a different sense than the modern one. Therefore, in the following sections, any reference to the modern meaning of convergence will be explicated, when necessary, in order to avoid ambiguities.

⁶²The use of moduli is required here, since from Gregory’s definition it is not specified whether $a_n < b_n$ or $b_n < a_n$, although in the examples made in *VCHQ* the order between the terms will be clearly determined. I also note that in Df. 9 the order relation: $\mid b_{n+1} - a_{n+1} \mid < \mid b_n - a_n \mid$ is explicated only for the first couples (a_0, b_0) , (a_1, b_1) . However, as it appears from sparse considerations made in *VCHQ*, Gregory had in mind the more general condition 7.3.2 when he discussed convergent sequences (a telling remark can be found in Scholium of proposition VI, where Gregory points out that in a convergent sequence one can find a couple of terms whose difference is smaller than any given quantity: “. . . igitur possunt inveniri huius seriei termini convergentes quorum differentia sit omni exhibita quantitate minor”, *Scholium* to proposition VI, *VCHQ*, p.18-19). This evidently entails that the difference between two corresponding terms b_n and a_n strictly decreases as n increases.

⁶³I remind that a sequence $\{p_n\}$ in a given metric space is Cauchy sequential if for every $\varepsilon > 0$ there is an integer N such that $d(p_n, p_m) < \varepsilon$ if $n \geq N$ and $m \geq N$. I also observe, with Scriba [1957], that even if Gregory’s concept of the convergence of the sequences $\{I_n\}$ and $\{C_n\}$ is dependent on the geometric framework from which they are derived, it: “. . . is formulated in such a abstract and neat way, that

It must be pointed out, however, that leaving aside the formal aspects of our own modern treatment of sequences, Gregory's characterization of convergence differs in two substantial aspects from our notion of Cauchy-sequentiality: as we have seen, convergence sequences in Gregory's sense are always considered as pairs of sequences recursively defined, and such that the differences between successive terms $\{a_n, b_n\}$ and $\{a_{n+1}, b_{n+1}\}$ approaches zero as n grows. Therefore, according to the sole conditions explicit in df. 9, even two sequences which do not satisfy the property of being Cauchy can comply with Gregory's definition of convergence, provided their differences can be taken arbitrarily small.⁶⁴

Definition 9 only partially characterizes the examples of convergent sequences presented and discussed in the book, even when they concern abstract quantities. Indeed, all the pairs of sequences considered in *VCHQ* share two fundamental properties besides the 7.3.1 and 7.3.2: firstly, they are composed by a monotonically increasing and a monotonically decreasing sequence, and secondly, each term of the first sequence is smaller than the corresponding term of the second one.

The paradigmatic example of convergent sequences in Gregory's sense is offered by the successions $\{I_n\}$ and $\{C_n\}$ of inscribed and circumscribed polygons constructed according to the protocol specified above. It is thus obvious from the construction that the series $\{I_n\}$ is monotonically increasing, and the series $\{C_n\}$ monotonically decreasing. Moreover, it is also clear that for any n , $a_n < b_n$.

Thus, even if Gregory did not succeed in giving a general and abstract definition of convergence, he provided a recursive definition of sequences $\{I_n\}$ and $\{C_n\}$ (condition 7.3.1) and a proof that the difference between two terms ($b_n - a_n$) can be made arbitrarily small (condition 7.3.2). On the ground of both conditions, Gregory finally proved that the limit of sequences $\{I_n\}$ and $\{C_n\}$ is not expressible in the given domain of analytical quantities.

today we can recognize in it the ε , which may not be absent from any modern criterion of convergence ... " (Scriba [1957], p. 15).

⁶⁴It is sufficient to consider, for instance, two unbounded sequences $\{a_n\}$ and $\{b_n\}$ which can obey the conditions stated by Gregory without being convergent in the sense of Cauchy. Accordingly, Dehn and Hellinger observe that: "this definition (namely, Gregory's definition of convergence) is not sufficient for our notion of convergence" (in Gregory [1939], p. 471).

7.3.3 The convergence of the double sequence

In the first six propositions of *VCHQ* Gregory reaches the following result: the double sequence $\{I_n, C_n\}$ formed by inscribed and circumscribed polygons to an arbitrary sector of the circle, according to the protocol specified above, is convergent in Gregory's sense, ie. complies with the following conditions:

1. $\begin{cases} I_{n+1} = S(I_n, C_n)^* \\ C_{n+1} = S'(I_n, C_n) \end{cases}$
2. $\forall n (C_{n+1} - I_{n+1}) < (C_n - I_n)$.

* I remind that S and S' refer, as in 7.3.1, to two particular compositions, or finite combination of compositions (in this case, both compositions are assumed analytical) that I will explain in the sequel.

Let us start by 1. In order to prove this theorem, Gregory employs the classical theory of proportions. He thus starts by proving, in propositions I and II of *VCHQ*, the following relations holding between the first couple of inscribed and circumscribed polygons, namely ABP and $ABFP$, and the second couple, namely $ABIP$ and $ABDLP$ (see fig. 7.3.1):

- $ABFP : ABIP = ABIP : ABP$
- $(ABFP + ABIP) : 2ABIP = ABFP : ABDLP$
- $(ABP + ABIP) : ABIP = 2ABIP : ABDLP$

In order to prove the first proportion, namely: $ABFP : ABIP = ABIP : ABP$, we will observe with Gregory that triangles ABF , ABI and ABQ lie on the same line and have the same height.

Therefore, by *Elements* VI, 1 they also stand in the same proportion as their basis:

- $ABQ : ABI = AQ : AI$
- $ABI : ABF = AI : AF$

Gregory then claims that AI is the mean proportion between AQ and AF . Since he did not offer any argument to support this claim, we suppose that he might have noted that, by construction, the segment BP is the polar of point P , so that the following relation holds: $AI^2 = AQ \cdot AF$.⁶⁵ Therefore basis AF , AI and AQ are in continuous proportion, which entails:

$$ABQ : ABI = ABI : ABF$$

Since, by construction: $ABF = \frac{ABFP}{2}$, $ABI = \frac{ABIP}{2}$ and $ABQ = \frac{ABP}{2}$, we will have:

$$ABP : ABIP = ABIP : ABFP$$

and, *permutando*:

$$ABFP : ABIP = ABIP : ABP \tag{7.3.3}$$

In order to prove the second proportion above, namely:

$$(ABFP + ABIP) : 2ABIP = ABFP : ABIP$$

let us start by observing that triangles ALF and ALI (see fig. 7.3.1 for instance) are constructed on the same line AF and have equal height IL , which implies, by *El.* VI, 1:

$$ALF : ALI = AF : AI$$

On the ground of the previous proof, we also know that:

$$ABF : ABI = AF : AI$$

⁶⁵See Whiteside [1961], p. 226. The pole-polar property is illustrated in *Coxeter and Greitzer [1996]*, p. 133.

and, multiplying the left members by the factor 2:

$$2ABF : 2ABI = AF : AI$$

This proportion yields:

$$ABFP : ABIP = AF : AI$$

From this and the previous proportion (namely $ALF : ALI = AF : AI$) we thus obtain:

$$ABFP : ABIP = ALF : ALI$$

Componendo, we obtain:

$$(ABFP + ABIP) : ABIP = (ALF + ALI) : ALI$$

and *duplicando*:

$$(ABFP + ABIP) : 2ABIP = AFP : 2ALI$$

By construction, $2ALI = AILP = \frac{ABDLP}{2}$ and $AFP = \frac{ABFP}{2}$ (see figure 7.3.1). This being so, from the previous proportion it can be immediately derived:

$$(ABFP + ABIP) : 2ABIP = ABFP : ABDLP \quad (7.3.4)$$

The third proportion listed above, namely:

$$(ABP + ABIP) : ABIP = 2ABIP : ABDLP$$

can be easily proved from 7.3.4 and 7.3.3. Indeed The latter yields the following proportion, *invertendo*:

$$ABIP : ABFP = ABP : ABIP$$

Componendo, we obtain from it:

$$(ABIP + ABFP) : ABFP = (ABP + ABIP) : ABIP$$

While from 7.3.4 we have, *permutando*:

$$(ABFP + ABIP) : ABFP = 2ABIP : ABDLP$$

From it we can immediately derive:

$$(ABP + ABIP) : ABIP = 2ABIP : ABDLP \tag{7.3.5}$$

Gregory recognized that analogous proportions hold between successive couples of inscribed and circumscribed polygons on the ground of the recursive construction protocol by which they are generated,⁶⁶ and chose to represent this recursive procedure through the symbolism of literal algebra.

⁶⁶In Gregory's words: "atque hinc evidens est has polygonorum analogias ita se habere in infinitum (...) alia et alia polygona intra et extra semper scribendo..." (*VCHQ*, *Scholium* to proposition V, p. 15).

Following Gregory's reasoning, we can set $ABP = I_0$ and $ABFP = C_0$. On the ground of 7.3.3 and 7.3.4, polygons $ABIP (= I_1)$ and $ABDLP (= C_1)$ can be thus expressed in terms of I_0 and C_0 :

$$\begin{cases} I_1 = \sqrt{I_0 C_0} \\ C_1 = \frac{2I_0 C_0}{I_0 + \sqrt{I_0 C_0}} \end{cases}$$

While the first equality is immediate, the second one can be derived by rewriting proportion 7.3.5 according to the symbolism above specified, and by simplifying the expression thus obtained.⁶⁷

Hence, by setting: $ABP = I_0$, $ABIP = I_1$, $ABDLP = C_1$, proportion 7.3.5 can be immediately rewritten as:

$$(I_0 + I_1) : I_1 = 2I_1 : C_1$$

Gregory plausibly derived from this proportion the following equality between ratios:

$$\frac{(I_0 + I_1)}{I_1} = \frac{2I_1}{C_1}$$

from which he obtained:

$$C_1 = \frac{2(I_1)^2}{I_0 + I_1}$$

⁶⁷See *Scholium* to proposition V, p. 15: "si ponatur triangulum $ABP = a$, & trapezium $ABFP = b$...". Instead of the letters 'a' and 'b' I have employed symbols: ' I_0 ', ' C_0 ', and so on. In the process of abstracting a convergent sequence from the corresponding recursive polygonal construction, Gregory presumably used the symbolism of literal algebra, together with arithmetical operations, in order to deal with regions of the plane, like polygons or sectors of a conic. The use of algebra of segments outside of the domain of segments is never undertaken by Descartes; nevertheless, it seems to me that no formal constraints impede such a move. In virtue of the tacit distinction between 'assertive' and 'determinative' algebras in Descartes' geometry, in fact, one can consider expressions like: ' $\sqrt{ab} = c$ ' or ' $\frac{2ab}{a + \sqrt{ab}} = c$ ' as perfectly meaningful even if a , b , c are polygons, and not segments, or if they are segments used in order to measure polygonal surfaces (I have examined this likelihood in the previous chapter, concerning van Heuraet's rectification). These expressions are simply compact formulations of proportions, and this is indeed the way Gregory treats them.

Since $I_1 = \sqrt{I_0 C_0}$ we can rewrite the previous equality as:

$$C_1 = \frac{2I_0 C_0}{I_0 + \sqrt{I_0 C_0}}$$

If we consider the sequences $\{I_n\}$ and $\{C_n\}$, the above relations can be generalized, on geometrical ground, to any couple of successive terms (I_n, C_n) and (I_{n+1}, C_{n+1}) , so that:

$$\begin{cases} I_{n+1} = \sqrt{C_n I_n} \\ C_{n+1} = \frac{2C_n I_n}{I_n + \sqrt{C_n I_n}} \end{cases} \quad (7.3.6)$$

This proves that sequences $\{I_n\}$, $\{C_n\}$ can be recursively defined in terms of two analytical compositions S and S' .

The convergence of the sequence $\{I_n, C_n\}$ is established in *VCHQ* by showing that the differences between the successive terms of the sequences $\{I_n\}$ and $\{C_n\}$, as n increases, approaches 0. Gregory proceeded by giving a direct proof of the following inequality:

$$C_1 - I_1 < \frac{1}{2}(C_0 - I_0) \quad (7.3.7)$$

and then he generalized 7.3.7 to any successive convergent terms, on the strength of the recursive polygonal construction.⁶⁸

In order to obtain this result, Gregory employed the rules of the classical theory of proportions. Thus, consistently with Gregory's way of proceeding, I will call $ABP = I_0$, $ABFP = C_0$, $ABIP = I_1$ and $ABDLP = C_1$.⁶⁹

In this way, proportions 7.3.3 and 7.3.5 can be rewritten as:

In this way, proportions 7.3.3 and 7.3.5 can be rewritten as:

$$(i) \quad I_0 : I_1 = I_1 : C_0$$

⁶⁸*VCHQ*, Prop. VI and in the successive *scholium*, p. 16-18.

⁶⁹In *VCHQ* capitals letters: $A, B, C \dots$ are employed to denote polygons.

$$(ii) (I_0 + I_1) : I_1 = 2I_1 : C_1$$

Gregory's proof of 7.3.7 starts by reducing (i) to:

$$(I_1 - I_0) : I_0 = (C_0 - I_1) : I_1 (\textit{Permutando\&separando})$$

which yields:

$$(I_1 - I_0) : (C_0 - I_1) = I_0 : I_1 (\textit{permutando})$$

and finally, by composition:

$$(iii) (C_0 - I_0) : (C_0 - I_1) = (I_0 + I_1) : I_1$$

(ii) yields instead, by alternation:

$$(I_0 + I_1) : 2I_1 = I_1 : C_1 (\textit{permutando})$$

This proportion can be further reduced:

$$(I_1 - I_0) : 2I_1 = (C_1 - I_1) : C_1 (\textit{permutando\&separando})$$

from which it follows, again by alternation:

$$(iv) (I_1 - I_0) : (C_1 - I_1) = 2I_1 : C_1 (\textit{permutando}).$$

We thus have, from (ii) & (iii):

$$(C_0 - I_0) : (C_0 - I_1) = 2I_1 : C_1$$

and, from this proportion and (iv) we obtain:

$$(v) (C_0 - I_0) : (C_0 - I_1) = (I_1 - I_0) : (C_1 - I_1)$$

We thus have, from (ii) & (iii):

$$(C_0 - I_0) : (C_0 - I_1) = 2I_1 : C_1$$

and, from this proportion and (iv) we obtain:

$$(v) (C_0 - I_0) : (C_0 - I_1) = (I_1 - I_0) : (C_1 - I_1)$$

Since $I_1 > I_0$ holds by construction, Gregory inferred the new inequality:

$$C_0 - I_0 > C_0 - I_1$$

Using (v), Gregory could also conclude:

$$(I_1 - I_0) > (C_1 - I_1)$$

By alternation, (v) yields the following proportion:

$$(C_0 - I_0) : (I_1 - I_0) = (C_0 - I_1) : (C_1 - I_1) \text{ (permutando)}$$

Since $C_0 > I_1$ by construction, we can infer that: $C_0 - I_0 > I_1 - I_0$. Therefore we will have also the following inequality:

$$C_0 - I_1 > C_1 - I_1$$

Since $C_0 - I_0 = (I_1 - I_0) + (C_0 - I_1)$, and both the following inequalities obtain:

$$\begin{cases} (I_1 - I_0) > (C_1 - I_1) \\ (C_0 - I_1) > (C_1 - I_1) \end{cases}$$

We can conclude:

$$C_0 - I_0 > 2(I_1 - C_1)$$

Or, in Gregory's words: "the difference between triangle ABP and trapezoid $ABFP$ is greater than the double of the difference between trapezoid $ABIP$ and the polygon $ABDLP$ ".⁷⁰

⁷⁰VCHQ, p. 16.

7.3.4 Computing the *terminatio*

Gregory takes for granted the existence of a limit ϖ to which the sequence $\{I_n, C_n\}$ approaches. He develops, on the other hand, some valuable considerations on the uniqueness of this limit. Indeed Gregory assumes, in the *scholium* of proposition V, that the sequence $\{I_n\}$ admits, in the space of geometric quantities, a last element (the "last inscribed polygon" as he calls it), and the sequence $\{C_n\}$ has a last element too, called, in this case, "last circumscribed polygon". In a slightly more modern terminology, we may say that Gregory assumes the existence of two polygons ϖ and ϖ' , such that $\sup \{I_n\} = \varpi$ and $\inf \{C_n\} = \varpi'$.

Then, on the ground of the convergence of the sequence $\{I_n, C_n\}$, Gregory argues, in the scholium to proposition VI, that the two corresponding polygons (*polygona complicata*) ϖ and ϖ' are such that their difference is less than any exhibited quantity. Indeed we have, by assumption, that for any n , $I_n < \varpi$ and $\varpi' < C_n$. Since the sequence $\{I_n, C_n\}$ is convergent (in Gregory's sense), we also have that polygons ϖ and ϖ' constitute a convergent term (ϖ, ϖ') , such that the difference $(\varpi' - \varpi) < (C_n - I_n)$ for every n .

Gregory concludes: "by imagining to continue this sequence [namely: $\{I_n, C_n\}$] infinitely, we can imagine the last convergent terms to be equal. We will call these equal terms, limit of the sequence".⁷¹ In other terms, we will have that: $\varpi' - \varpi = 0$, hence $\varpi' = \varpi$. This quantity is called limit or, in the original, '*terminatio*' of the sequence, and it coincides, on the ground of the geometric model of the problem, with the conic sector itself.⁷²

Eventually, the problem became for Gregory whether this quantity was expressible as an analytical composition of the elements of the successions $\{I_n\}$ and $\{C_n\}$ of inscribed and circumscribed polygons:

si igitur praedicta polygonorum series terminari posset, hoc est, si inveniretur ultimum illud polygonum inscriptum (ita loqui licet) aequale ultimo illo polygono circumscripto, daretur infallibiliter circuli et hyperbolae quadratura: sed quoniam difficile est in geometria, omnino fortasse inauditu tales series terminare, praemittendae sunt quaedam propositiones e quibus inveniri possint

⁷¹"... imaginando hanc seriem in infinitum continuari, possumus imaginari ultimos terminos convergentes esse aequales, quos terminos aequales appellamus seriei terminationem." (*VCHQ*, p. 19).

⁷²*VCHQ*, p. 18-19.

huiusmodi aliquot serierum terminationes, et tandem (si fieri possit) generalis methodus inveniendi omnium serierum convergentium terminationes.⁷³

Gregory contrived to formulate a general procedure for searching and exhibiting the 'terminatio' of an arbitrary convergent sequence, possibly with the hope that the most difficult cases, like the one related to the quadrature of the central conic sections, would fall under such a method.⁷⁴

His fundamental idea can be briefly explained. Gregory assumed that it was sufficient, in order to find the limit of an arbitrary convergent sequence of this form:

$$\begin{cases} a_{n+1} = M(a_n, b_n) \\ b_{n+1} = M'(a_n, b_n) \end{cases}$$

where M and M' are (analytical) compositions, to determine an invariant composition S such that: $S(a_n, b_n) = S(a_{n+1}, b_{n+1})$.

Indeed, let us suppose that such a limit exists, and call it z . Since S is, by definition, an invariant composition for any couple (a_n, b_n) , we will have that:

$$S(a_0, b_0) = S(a_1, b_1) = \dots = S(a_n, b_n) = \dots = S(z, z)$$

According to Gregory's understanding of convergent sequences - which, as I have shown, does not fully coincide with his explicit definition, but it is moulded on the geometric models treated in *VCHQ* - $\{a_n\}$ is a bounded monotonically increasing succession, such that: $\lim_{n \rightarrow \infty} \{a_n\} = z$, and $z \in \{a_n\}$ and $\{b_n\}$ a bounded monotonically decreasing one, such that $\lim_{n \rightarrow \infty} \{b_n\} = z'$ and $z' \in \{b_n\}$. Moreover, the difference between the limits ($z' - z$) is strictly inferior than the difference ($b_n - a_n$), for every n , and eventually,

⁷³ *VCHQ*, *Scholium* to proposition V, p. 15: "If then the said sequence of polygons could be terminated, namely, if it were found the last inscribed polygon (if I may say) equal to the last circumscribed polygon, we would have without error the quadrature of the circle and the hyperbola. But since it is difficult in geometry, and perhaps at all incredible to terminate this series, we have to premise some propositions, from which the terminations of likewise series can be found, and finally (if it can be done) a general method for the discovery of the terminations of all convergent series".

⁷⁴ *VCHQ*, p. 19-24. See also Gregory [1939], p. 472 - 473, Scriba [1957], p. 16-17.

these limits coincide: we will have: $z' = z$, so that the last convergent term can be represented as: (z, z) .

In order to find z , it is sufficient to solve the following equation:

$$S(a_0, b_0) = S(z, z) \tag{7.3.8}$$

As a_0, b_0 are known terms, the term z can be computed once the composition S is known: if S is analytical, for instance, z can be determined by solving an algebraic equation with coefficients a_0, b_0 .

The real problem, therefore, according to Gregory's account, would be to find such a composition S . Gregory correctly observes that, since the composition S is invariant for two arbitrary couples $(a_n, b_n), (a_{n+1}, b_{n+1})$ it will satisfy the equation: $S(a_0, b_0) = S(a_1, b_1)$.

Hence, the problem of computing the limit of a convergent sequence is solved if an invariant composition of the first and of the second couple can be found, as we can read in *VCHQ*, proposition X:

Et proinde ad inveniendam cujuscumque seriei convergentis terminationem; opus est solummodo invenire quantitatem eodem modo compositam ex terminis convergentibus primis quo componitur eadem quantitas ex terminis convergentibus secundis.⁷⁵

A better grasp of Gregory's procedure can be given by an example presented by Gregory in his letter published in *Philosophical Transactions* (July 1668), written as a response to critique moved by Huygens.⁷⁶

⁷⁵ *VCHQ*, p. 24: "And, conclusively, in order to find the terminatio of any convergent sequence, one only needs to find a quantity composed in the same way from the first convergent terms, as from the second convergent terms". Dehn and Hellinger (in Gregory [1939]) maintain that Gregory's expression *eodem modo* must be interpreted in the sense of a syntactical identity: $S(a_0, b_0) \equiv S(a_1, b_1)$, as in " $S(a_0, b_0)$ and $S(a_1, b_1)$ are the same variable", that is, the combination of symbols on the left side of \equiv is the same as combination on the right. I surmise that this specification is important in connection with the impossibility argument I will discuss in the next session, and therefore I share Dehn and Hellinger's interpretation, leaving the symbol "=" by commodity and trusting the alertness of the reader.

⁷⁶ In a letter addressed to Gallois from 2nd July 1668, Huygens had claimed that one of the examples of convergent sequences offered in *VCHQ* actually failed to converge, according to the definition of

In this letter, Gregory examines the convergent sequence $\{a_n, b_n\}$ with $0 < a_n < b_n$, defined recursively as it follows:

$$\begin{aligned} a_0 &= a \\ b_0 &= b \end{aligned} \tag{7.3.9}$$

$$\begin{cases} a_{n+1} = \frac{2a_n b_n}{a_n + b_n} \\ b_{n+1} = \frac{a_n + b_n}{2} \end{cases} \tag{7.3.10}$$

Although the convergence of this sequence is not proved by Gregory, a proof can be easily supplemented.⁷⁷ Gregory's aim was rather to show that this sequence had a unique limit, analytical with its terms.

In virtue of the recursive nature of the sequences, an arbitrary couple (a_k, b_k) of terms, $a_k \in \{a_n\}$ and $b_k \in \{b_n\}$, can be written as:

$$\begin{cases} a_k = \frac{2a_{k-1}b_{k-1}}{a_{k-1} + b_{k-1}} \\ b_k = \frac{a_{k-1} + b_{k-1}}{2} \end{cases}$$

From which it appears that the product of a_k and b_k , equals the product of a_{k-1} , b_{k-1} :

$$a_k b_k = \left(\frac{2a_{k-1}b_{k-1}}{a_{k-1} + b_{k-1}} \right) \left(\frac{a_{k-1} + b_{k-1}}{2} \right) = a_{k-1} b_{k-1}$$

convergence given in df. 9 (see Huygens [1888-1950], vol 6, p. 229). The example criticized by Huygens, and discussed in *VCHQ* (prop. X, p. 23) concerns two sequences $\{a_n\}$ and $\{b_n\}$, defined via the following recursive relations: $a_1 = \sqrt{a_0 b_0}$ and $b_1 = \frac{a_0^2}{\sqrt{a_0 b_0}}$. Huygens does not explain why this couple of sequences fails to converge, but the error can be easily detected. Indeed, it is sufficient to remark that, in virtue of the recursive definition of sequence $\{a_n\}$, we have: $a_2 = \sqrt{\sqrt{a_0 b_0} \cdot \frac{a_0^2}{\sqrt{a_0 b_0}}} = a_0$, and: $b_2 = \frac{a_1^2}{\sqrt{a_1 b_1}} = \frac{a_0 b_0}{a_0} = b_0$. Hence, the sequence cannot comply with Gregory's notion of convergence. Gregory acknowledged the correctness of Huygens' criticism and amended to his previous faulty example by proposing another pair of sequences, for which he proved the convergence and, on the top of this, computed the termination.

⁷⁷The condition 7.3.1 and 7.3.2 are satisfied since the following inequalities hold: $\begin{cases} a_n < \frac{2a_n b_n}{a_n + b_n} < b_n \\ a_n < \frac{a_n + b_n}{2} < b_n \end{cases}$.

From it, it is immediate to conclude: $\frac{a_n + b_n}{2} - \frac{2a_n b_n}{a_n + b_n} < b_n - a_n$. Thus, for any n : $b_{n+1} - a_{n+1} < b_n - a_n$.

Hence, as a consequence, if the recursive nature of the successions $\{a_n\}$, $\{b_n\}$, we have that:

$$a_k b_k = a_{k-1} b_{k-1} = \dots = a_1 b_1 = ab$$

The product between terms a_k and b_k is invariant for any choice of the index k . From this, Gregory concluded that for any couple (a_k, b_k) the product of its terms equals the product of the known initial terms a and b :

termini priores inter se multiplicati efficiunt ab , item sequentes inter se multiplicati efficiunt eandem ab , ex his invenienda sit propositae seriei terminatio. Manifestum est, quantitatem ab eodem modo fieri a terminis convergentibus a , b , quo a terminis convergentibus immediate sequentibus $\frac{2ab}{a+b}$, $\frac{a+b}{2}$: & quoniam quantitates a , b , indefinite ponuntur pro quibuslibet totius seriei terminis convergentibus, evidens est, duos quoscunque terminos convergentes propositae seriei inter se multiplicatos idem efficere productum, quod faciunt termini immediate sequentes etiam inter se multiplicati; cumque duo termini convergentes duos terminos convergentes semper immediate sequantur, manifestum est, duos quoscunque terminos convergentes inter se multiplicatos idem semper efficere productum, nempe ab .⁷⁸

Following the reasoning deployed in the letter, we can suppose that sequences $\{a_n\}$ and $\{b_n\}$ tend to limits z and z' , so that the couple (z', z) terminates the *series convergens*. Moreover, because of the convergent character of the sequence, we have that $z' - z = 0$. We can thus write: $z = z'$.

On the other hand, the recursive character of the sequences under examination allows us to establish the following equality:

$$z.z = \dots = a_k b_k = a_{k-1} b_{k-1} = \dots = a_1 b_1 = ab$$

⁷⁸Huygens [1888-1950], vol VI, p. 241, 242. In my translation: "The first terms multiplied one by the other yield ab , then the next ones multiplied one by the other give the same ab , from them the limit of the proposed *series* must be discovered. It is plain that the quantity ab is composed in the same way from the convergent terms a and b as from the convergent terms immediately following, $\frac{2ab}{a+b}$, $\frac{a+b}{2}$; and since quantities a and b can stand for any term of the convergent sequence, indefinitely, it is evident that any two convergent terms of the proposed series multiplied one to another yield the same product, obtained from the immediately following terms multiplied one by the other; and since two convergent terms are always immediately followed by two other convergent terms, it is plain that two arbitrary convergent terms multiplied between them always yield the same product, namely ab ".

From it, Gregory can derive a quadratic equation in z :

$$z.z = z^2 = ab$$

and then solve z in terms of a and b (both assumed positive):

$$z = \sqrt{ab}$$

In conclusion, the termination of this sequence is the geometric mean of the initial terms a , b , and can be therefore computed analytically from the terms themselves.⁷⁹

7.4 An argument of impossibility

The method devised by Gregory in order to compute the limit of an arbitrary convergent sequence can in principle be applied also to compute the limit of the successions $\{I_n\}$ and $\{C_n\}$ of inscribed and circumscribed polygons to a given conic sector. Indeed, if it is possible to find a composition S of I_i and C_i , such that:⁸⁰

$$S(I_n, C_n) = S(I_{n+1}, C_{n+1}),$$

The ‘terminatio’ ϖ , whose existence is warranted on geometrical grounds (it is represented by the sector itself), may be computed, according to the procedure described in 7.3.8, out of an algebraic equation of the form:

$$S(I_0, C_0) = S(\varpi, \varpi)$$

⁷⁹See Gregory [1939], p. 473. Gregory’s conclusion is correct; moreover, it is mathematically interesting. Indeed we can recognize, in the example proposed by Gregory, the arithmetico-harmonic mean iteration, which is known to converge quadratically. Thus, referring to the double succession defined by conditions 7.3.9 and 7.3.10, we will have that: $\lim_{n \rightarrow \infty} a_n = \lim_{n \rightarrow \infty} b_n = \sqrt{a_0 b_0}$ (See Borwein and Borwein [1998], p. 4, for further details, and the considerations made by Dehn and Hellinger, in Gregory [1939], p. 473).

⁸⁰See corollary (*consectarium*) to proposition X. *VCHQ*, p. 24.

Following Gregory's reasoning, if the limit could be expressed analytically in terms of I_0 and C_0 , then it could be expressed by the same analytical composition S in terms of I_1 and C_1 . Therefore, the following identity would hold:

$$S(I_0, C_0) = S(I_1, C_1) = S\left(\sqrt{I_0 C_0}, \frac{2I_0 C_0}{I_0 + \sqrt{I_0 C_0}}\right) \quad (7.4.1)$$

This is, I surmise, the implicit starting point of Gregory's impossibility argument. Thence Gregory argued that (i) no analytical composition satisfying the above identity could be found, and allegedly concluded that the limit ϖ was not analytical with the terms of the sequences (ii):

Dico sectorem circuli, ellipseos vel hyperbolae $ABIP$ non esse compositum analytice a triangulo ABP et trapezio $ABFP$.⁸¹

This implied, he concluded, that the sector of the conic could not be squared geometrically. This conclusion would be vehemently denied by Huygens in the aftermath of the publication of $VCHQ$, on the ground of two major objections.⁸² I observe now, in the light of our discussion, and in accord with one of the criticisms advanced by Huygens (to be analyzed in the next section) that Gregory's method, explicated at proposition X of $VCHQ$, merely offers a sufficient condition of solvability for the problem of computing the termination ϖ of our series, composed by inscribed and circumscribed polygons. Hence, we are entitled to conclude that, if a finite analytic composition satisfying the identity 7.4.1 could be found, ϖ could be expressed by a finite combination of elementary operations from a couple of inscribed and circumscribed polygons. But on the sole ground of this implication, we are not entitled to infer the contrary, namely: if *no* finite analytic composition satisfying the identity 7.4.1 could be found, ϖ could *not* be expressed by a finite combination of elementary operations from a couple of inscribed and circumscribed polygons.

⁸¹ "I claim that the sector of the circle, the ellipse or the hyperbola $ABIP$ cannot be composed analytically from the triangle ABP and the trapezium $ABFP$ ". proposition XI, $VCHQ$, p. 29.

⁸²The same criticism would be later reenacted and expanded by Leibniz. See this study, ch. 8, sec. 8.6.1.

Yet, according to the unanimous opinion of his readers, Gregory proceeded in this way, committing a *non sequitur*. Leaving this flaw aside for the moment, let us streamline Gregory's first stage of his impossibility argument, in which he set out to deny the following claim (proposition XI):

Theorem 1. *There is an analytical composition S , such that for every sector ω of the circle (resp. the hyperbola) and its corresponding inscribed and circumscribed polygons I_0, C_0 , we have that: $S(I_0, C_0) = S(\omega, \omega)$.*

I note that this proposition presents a complex logical structure in which two quantifiers are present: an existential and a universal one. Gregory proceeded by few stages. The first stage is preparatory, and consists in removing the irrationalities contained in 7.3.6 (namely: $\left\{ \begin{array}{l} I_{n+1} = \sqrt{C_n I_n} \\ C_{n+1} = \frac{2C_n I_n}{I_n + \sqrt{C_n I_n}} \end{array} \right.$) by a rational parametric representation in a and b , supposed positive.⁸³ The transformation staged by Gregorie is the following one:

$$ABP = I_0 = a^2(a + b)$$

$$ABFP = C_0 = b^2(a + b)$$

Relying on 7.3.6, the terms of the second couple can be parametrized in a and b too. We have, therefore:

$$ABIP = I_1 = \sqrt{C_0 I_0} = ab(a + b)$$

$$ABDLP = C_1 = \frac{2C_0 I_0}{I_0 + \sqrt{C_0 I_0}} = 2ab^2$$

Gregory thus supposes that an analytical composition S exists, which satisfies the identity:

$$S(a^2(a + b); b^2(a + b)) = S(ab(a + b); 2ab^2) \quad (7.4.2)$$

⁸³VCHQ, proposition XI, p. 25.

and derives a contradiction from this assumption. Hence, he concludes that the limit, or ‘terminatio’, cannot be analytic with the terms of the sequence.⁸⁴

Gregory’s reasoning is based on two arguments which depend on the structure of the expressions $S(a^2(a+b); b^2(a+b))$ and $S(ab(a+b); 2ab^2)$, interpreted as finite non-zero polynomials in either the variable a or b , and supposedly with real algebraic coefficients (although we find, in *VCHQ*, no indication concerning this issue). Firstly, he points out that the terms in the left side of the identity 7.4.2 are inhomogeneous with the terms of the right side (the term a appears, if we expand the expressions which figure as arguments of S , up to the third power, while the right side contains it only up to the second power, and the same occurs for the term b). Secondly, Gregory remarks the right side of the identity contains a monomial term (namely $2ab^2$), while on the left side both terms are binomials. Thence, Gregory concludes that if the same finite succession S of elementary operations is applied to the expression $(a^2(a+b); b^2(a+b))$ and to the expression $(ab(a+b); 2ab^2)$, the resulting polynomial in the left side of the identity 7.4.2 will always exhibit either terms a or b raised to a higher power than the corresponding terms of polynomial in the right side. As for the second argument, concerning monomials, Gregory argues, along similar lines, that under any finite combination of additions, subtractions, multiplications, divisions and root extractions, the polynomial in the left-side of the supposed identity will be composed by more terms than the polynomial in the right side.⁸⁵

On the strength of these arguments, Gregory states that no finite combination S of analytical compositions exists, capable of satisfying the 7.4.2. I observe, together with Dehn and Hellinger (in Gregory [1939], p. 476), and Whiteside (in Whiteside [1961], p. 270), that the attempt to prove the non-analytical squarability of a central conic sector starting from the algebraic parametrization proposed by Gregory, and following his subsequent reasoning, has noticeable technical flaws. I shall sketch in what follows two of these flaws. Firstly, Gregory’s proof is incomplete. Indeed, as we have seen, his alleged proof is ultimately based on two structural differences between the polynomial $S(a^2(a+b); b^2(a+b))$ and the polynomial $S(ab(a+b); 2ab^2)$: according to Gregory, they are non-homogeneous and they are composed by a different number of terms. Gregory could easily conclude that, if S is a linear combination of the first and the second arguments

⁸⁴See Hofmann [2008], p. 65, Dehn&Hellinger, in Gregory [1939], p. 475.

⁸⁵*VCHQ*, p. 27-28.

in 7.4.2, the polynomial in the left side has higher degree than the polynomial in the right side. However, he was not able to prove successfully that the identity 7.4.2 led to contradiction when S is a rational or irrational function of the arguments, thus leaving his proof incomplete.⁸⁶ Secondly, Gregory's argument is undermined by a counterexample, as pointed out in Dehn and Hellinger's commentary (Gregory [1939]) and in Whiteside's reconstruction (Whiteside [1961]).⁸⁷

But, perhaps surprisingly to us, early modern geometers hardly contested these technical inaccuracies. On the contrary, one of the major motives of criticism raised with respect to proposition XI of *VCHQ* concerned the legitimacy of inferring, from the impossibility of finding an analytical composition S , which satisfies equation 7.4.1, the impossibility of the analytical quadrature of the corresponding sector.

This is indeed how Gregory reasons. Once having inferred that no S exists such that: $S(I_0, C_0) = S(\varpi, \varpi)$, he concludes that the limit of the convergent sequence formed by successions $\{I_n\}$, $\{C_n\}$, starting from I_0 and C_0 , and recursively defined as in 7.3.6, is not analytic with the convergent terms. As I have stressed before, the limit exists geometrically: it is the sector \widehat{APB} . On the ground of proposition XI, Gregory claims:

Ex hactenus demonstratis manifestum est sectorem $ABIP$ [\widehat{APB} in my narration] non posse componi ex addicione, subductione, multiplicatione, divisione et radicum extractione trianguli ABP et trapezii $ABFP$. Triangulum ABP et trapezium $ABFP$ supponimus esse quantitates inter se analyticas, et proinde sector $ABIP$ [\widehat{APB} in my narration] illis analytica esse non potest, hoc est ex quantitatibus ipsis ABP $ABFP$ analyticarum addicione, subductione, multiplicatione divisione et radicum extractione componi non potest.⁸⁸

⁸⁶Gregory [1939], p. 475 - 476.

⁸⁷In their account of *VCHQ*, in fact, Dehn and Hellinger prove that: $C_1 \sqrt{\frac{I_1}{C_1 - I_1}} = 2C_0 \left(\sqrt{\frac{I_0}{C_0 - I_0}} \right)$, which shows unequivocally that there is at least one analytic composition S which remains invariant with respect to the couples (I_0, C_0) and (I_1, C_1) , a part from a factor 2. The same result is verified by Whiteside (in Whiteside [1961], p. 269). I note that the case of the quadrature of the hyperbola is analogous. In this case we have in fact: $C_0 < I_0$, therefore we need only to interchange C_0 and I_0 and to replace the tan-function by the inverse of the hyperbolic tangent function. By letting imaginary numbers in our reasoning, we recognize that we obtain a similar same analytic function, since $\tanh ix = i \tan x$.

⁸⁸"It is evident that the sector $ABIP$ [\widehat{APB} in my narration] cannot be composed from the addition, subtraction, division and extraction of roots of the triangle ABP and of the trapezium $ABFP$. We suppose that triangle ABP and trapezium $ABFP$ are quantities analytical between them; hence the sector $ABIP$ [\widehat{APB} in my narration] cannot be analytical with them, that is, it cannot be composed by the addition, subtraction, multiplication, division and root extraction of the analytical quantities ABP and $ABFP$." *VCHQ*, p. 29.

Eventually, Gregory argues that the sector \widehat{APB} is not analytical with the polygons ABP and $ABFP$. It should be pointed out that interpretations diverge on the precise significance of this result in geometry. In his Scriba [1983], for instance, Scriba understands Gregory's claim that the sector \widehat{APB} cannot be analytically composed from polygons ABP and $ABFP$ as implying that the sector cannot be obtained from the convergent polygons by applying rational operations and square-root extractions only. In other words, Scriba advocates a distinction between the notion of 'analytic' employed by Gregory and our notion of 'algebraic'. According to his interpretation, when Gregory states that an arbitrary sector \widehat{APB} of a central conic cannot be "analytical" with the terms of the double sequence $\{I_n, C_n\}$ he intends, firstly, that the area of the sector cannot be expressed as a rational function of these terms and, on the top of this, that it cannot be obtained from them by any combination of the arithmetic operations and the extraction of square roots. When this claim is translated into geometry, it amounts to saying that the sector cannot be constructed by ruler and compass. Scriba motivates his claim on the consideration that the terms of the convergent sequence $\{I_n, C_n\}$ form a set closed under the operations \pm, \times, \div , and the extraction of square roots: in a modern vest, this is equivalent to say that these terms belong to a quadratic extension of \mathbb{Q} , supposing that the initial terms I_0 and C_0 are rational.⁸⁹

However, in my view, the notion of 'analytic composition' ought to be given a less restrictive interpretation. In fact, as I have recalled before too, Gregory gave the following definition of 'analytic composition', probably in accord with Descartes' algebra of segments:

When a quantity is composed from the addition, subtraction, multiplication division and extraction of roots (*radicum extractione*); we say that it is composed analytically.⁹⁰

According to my interpretation, this definition can be understood as including, among analytical compositions, the extraction of roots of arbitrary order k : correspondingly, analytical quantities are, in Gregory's views, those quantities generated from given ones by applying the usual arithmetical operations and the extraction of the k -th root of either one of the given quantities (*cf.* df. 7, *VCHQ*, p. 9). For this reason, I hold that, when Gregory states, in proposition XI, that: "the sector $ABIP$ [\widehat{APB} in my narration] cannot

⁸⁹Scriba [1983], p. 283.

⁹⁰*VCHQ*, df. 6, p. 9.

(...) be composed by the addition, subtraction, multiplication, division and root extraction (*radicum extractione*) of the analytical quantities ABP and $ABFP$ ", he intends that the sector cannot be obtained as the result of a finite concatenation of algebraic operations bearing on given quantities, or, to state the same fact in geometric terms, it cannot be exhibited through a geometric construction, namely a licensed construction in cartesian geometry.

As it appears from the account given in *VCHQ*, Gregory took the inference from the non-existence of S to the impossibility of squaring the sector analytically (i.e. algebraically) for granted. I remark that the sector \widehat{APB} is chosen arbitrarily, and may be thus replaced with any other sector of the circle (resp. the hyperbola), included the whole circle itself. On this ground, Gregory could also infer the impossibility of squaring the whole circle analytically.⁹¹

This conclusion, as I will illustrate in the next section, will be strongly denied by Gregory's recipients: C. Huygens and John Wallis. In more recent times, Dehn and Hellinger agree that: "in Gregory's treatise we find no proof for the impossibility of squaring the circle", and more generally, a given sector of a central conic.⁹²

Dehn and Hellinger argue that the only impossibility result provided by Gregory consists in denying theorem 1 above, for which, the commentators note: "it would be sufficient to give the proof that tan-function is not an algebraic one". This claim is correct: if we call φ the half of the arc delimiting the sector \widehat{APB} (namely: $\frac{\widehat{APB}}{2} = \varphi$), we can derive, on the ground of our geometrical model, the following parametrization for the areas of the polygons $ABP = I_0$ and $ABFP = C_0$ (we take r for the radius):

$$\begin{cases} I_0 = \frac{r^2}{2} \sin 2\varphi \\ C_0 = r^2 \tan \varphi \end{cases}$$

⁹¹In one passage of *VCHQ*, at least, Gregory assumes that his impossibility result concerns the quadrature of the whole circle as well: "Since it is proved that the ratio of the circle to the square if its diameter is not analytical, searching for it will be certainly vain and unseless search for it, as it is an impossible task as such" (*VCHQ*, p. 29). In the preface of *GPU*, on the other hand, Gregory overtly referred to the impossibility of finding an analytical proportion between the circle and the square built on its diameter, thus proving that he intended to cover, by his result on the impossibility of the analytical quadrature, also the traditional circle-squaring problem (*GPU*, p. 6).

⁹²In Gregory [1939], p. 475.

This shows that the areas of the polygons I_0 and C_0 depend solely on the tangent of φ and on the radius (indeed $\sin 2\varphi = \frac{4 \tan \varphi}{1 + \tan^2 \varphi}$). Since the radius is constant, and can be taken equal to 1, it is sufficient to prove that an algebraic equation relating the area A of a sector, that is: $A = 2\varphi r^2$, and the tangent of φ does not exist.⁹³

In order to prove that no analytic, or algebraic composition S can exist, it is sufficient to show that the tan-function (or the corresponding tanh-function, in the case of the hyperbola) is not algebraic either. This conclusion confirms Dehn and Hellinger's remark. One can be easily convinced of this by considering that the equation: $\tan x = y$ remains invariant for the transformation $x' = x + \pi$. Therefore, the graph of tan-function intersects the x-axis in an infinite number of points: this proves that tan-function has an infinite number of zeroes, hence it is transcendental.⁹⁴

The theorem proved by Gregory in proposition XI of *VCHQ* does not concern, strictly speaking, the quadrature of a sector, nor the circle-squaring problem in its traditional sense or, examined under the lense of modern mathematics, the transcendental nature of π . Even if it is impossible to find a unique analytical (or algebraic, as we would say) composition S , which can solve the quadrature of an arbitrary sector of a central conic, an algebraic equation with rational coefficients may still exist, which relates particular sectors to their corresponding inscribed and circumscribed polygons. The reason can be briefly exposed: the fact that the function \tan (or \tanh) is transcendental, and therefore cannot coincide with an algebraic curve, does not exclude that the coordinates of each point of the curve $y = \tan x$ may satisfy a particular algebraic equation with rational coefficients, or that the curve may contain special points, whose coordinates satisfy an algebraic equation.⁹⁵

Within this setting, the question concerning the quadrature of the whole circle amounts to ask whether its area, namely πr^2 , or the area of one of its of its rational submultiple sectors, namely $k \frac{\pi}{n} r^2$, can be expressed as an algebraic function of the corresponding tangents: $\tan(k \frac{\pi}{n})$, in which $k, n \in \mathbb{N}$ ($n \neq 2$). If the circle was algebraically squarable,

⁹³We can adopt a similar parametrization for the case of the hyperbola, using the hyperbolic functions \sinh and \tanh instead of \sin and \tan . If we put $\frac{\widehat{APB}}{2} = \varphi$ and $r = AB$ (or AP), we will have in this case: $I_0 = \frac{r^2}{2} \sinh 2\varphi$ and $C_0 = r \tanh \varphi$. Thence, the question for the case of the quadrature of an hyperbolic segment would be whether we can find an algebraic equation such that: $P(\varphi, \tanh \varphi) = 0$.

⁹⁴Dehn and Hellinger make this point in Gregory [1939], p. 475.

⁹⁵This problem is discussed in B. Calò's essay *Sui problemi trascendenti e in particolare sulla quadratura del circolo*, in Enriques [1912], p. 18, vol 2.

then its rational sectors would be squarable too. Therefore it would be sufficient to inquire whether it exists an algebraic equation holding among a sector $\frac{\pi}{2}r^2$ (its quarter) and the corresponding inscribed and circumscribed polygons, namely $I_0 = \frac{r^2}{2} \sin \frac{\pi}{2} = \frac{r^2}{2}$ and $C_0 = r \tan \frac{\pi}{4} = r$, which are obviously function of the radius r of the circle.

The answer to this problem is negative, as we know, since π is a transcendental number, and cannot be the root of an algebraic equation in rational coefficients. However, neither the transcendence nor the irrationality of π seem to be derivable from Gregory's impossibility claim.⁹⁶

7.5 Reception and criticism of Gregory's impossibility argument

As evoked in section 7.3.2, a bitter controversy ensued between James Gregory and Christiaan Huygens, almost one year after the publication of *VCHQ*, over the contributions allegedly achieved in the treatise. In this section, I will examine Huygens' criticism moved towards Gregory's impossibility result and Gregory's subsequent reactions. Among the outstanding characters who were involved in the controversy, I will consider also the role played by Wallis, who, I surmise, had an active part in evaluating the mathematical import of Gregory's impossibility claims.

Moreover, Wallis had a primary interest in the controversy, since he had himself conjectured, in the *Arithmetica infinitorum*, that the ratio between the circle and the square

⁹⁶B. Calò, in his essay on transcendental problems, distinguishes clearly between the problem of squaring an arbitrary sector of the circle, that concerns, in modern terminology, the theory of algebraic and transcendental functions, from the problem of squaring the whole circle or one of its rational submultiples, a problem which, properly speaking, concerns arithmetic and the theory of numbers. In this second case, in fact, the question concerning the possibility of the quadrature of the circle would depend on the answer to the following crucial questions: are there transcendental numbers, namely numbers which do not satisfy any algebraic equations in rational coefficients? And is π a transcendental or algebraic number? The answers, as known, will be given in the second half of XIXth century with methods extraneous to the context of XVIIth century mathematics. However, even if Gregory's attempt at establishing the impossibility of the analytical quadrature of an arbitrary sector leaves untouched the question about the algebraic or transcendental nature of π , one must take into account that his procedure of polygonal constructions is mathematically fruitful as far as it offers important insights into the computation of π , as shown at length by the study of Scriba [1983] (in particular, p. 279-282). As Scriba discovered, two of the most important representations of π , namely, Viète's infinite product for $\frac{2}{\pi}$ and the arctan series (that will be known as Leibniz's series) are implicit in Gregory's construction, although, in order to make this connection explicit, one should have recourse to tools of XIXth century mathematics, that were obviously unknown to Gregory and to his contemporaries.

built on its diameter, namely π could not be expressed in known numbers.⁹⁷

Huygens formulated two main objections against Gregory's assertion on the impossibility of the analytical quadrature of a central conic section and against the arguments invoked in *VCHQ* to support it.

The first of Huygens' objections is exposed in the letter from 2nd july 1668 that we may also take as the opening act of the controversy:

"... encore que cela soit vray [namely, that the 'terminatio' is analytical with the double sequence] lors que la terminaison est trouvée par la methode qu'il [Gregory] enseigne, on n'en peut pas tirer une conclusion generale; à moins que de supposer qu'on ne peut trouver que par sa methode la terminaison d'une suite de grandeurs, qu'il appelle convergentes, ou que si on la trouve par une autre voye, on la pourra aussi trouver par sa methode; ce qu'il n'a pas démontré.⁹⁸

Huygens held that the impossibility of the analytical quadrature of a central conic could not be deduced merely on the ground of the arguments deployed in proposition X and XI of *VCHQ*, unless one could prove that a convergent sequence tends to an analytical limit *only if* this limit can be found according to the method prescribed by Gregory, or that any method capable of computing the limit was eventually reducible to Gregory's one.⁹⁹

Huygens' criticism casts light on a major general flaw of Gregory's impossibility argument. Indeed, while Gregory tried to characterize abstractly, i. e. independently from the geometric model of reference, the recursive character of his convergent sequences, his overall conception of these entities appears to be still dependent from the geometric problems which engendered them.¹⁰⁰ Gregory's impossibility result too is derived from a special geometric configuration, and because of this reason it might not be enough

⁹⁷Wallis [2004], p. 161.

⁹⁸In Huygens [1888-1950], vol. 6, p. 229.

⁹⁹The gist of Huygens' criticism can be synthetized, following [Dijksterhuis, 1939], with the following words: "Huygens denied the right to assume that the common limit t of the two series $a_1, a_2 \dots$ and $b_1, b_2 \dots$ if it exists, can always be expressed analytically in a_1 and b_1 ". See Dijksterhuis [1939], in Gregory [1939], p. 483.

¹⁰⁰This can be evinced, for instance, from the very definition of convergent sequence: in fact, as explicited in df. 9, Gregory envisages convergent sequences as two-term recursions instead of single successions, betraying their origin from the polygonal double sequences approximating a given sector.

general in order to rule out other possible constructions that might solve the quadrature problem simply appealing to a different procedure.

Gregory's almost immediate reaction to this objection appeared, in the *Philosophical Transactions* n. 37, from 13 July 1668, as a letter to Oldenburg.¹⁰¹ The main point of his response consisted in denying the very legitimacy of Huygens's criticism, by remarking that Huygens had not offered any counterexample - for instance a convergent sequence, whose limit was analytical with its terms and yet not computable through Gregory's method - or, more generically, any further motivation that might give solid ground for doubting ("*solidam dubitandi rationem*") proposition XI and its *Scholium*.¹⁰²

At an initial stage of this controversy, Gregory's response received the approval of mathematicians, like Collins or Wallis, who judged Huygens' criticism misgiven. For example, we can read in a letter sent by Wallis to Oldenburg in August 1668:

Mr Gregories 10th Proposition, as to what it undertakes (if I mistake not his meaning) seems well inough demonstrated; viz. that those converging series, cannot bee so terminated by Analytical operation as he proposeth. But (what Mr Hugens exceptions do oppose) that there can be no other Analytick means of squaring the Circle or Hyperbole; is not (at lest there) affirmed, & therefore was not to bee proved.¹⁰³

However, this judgement was drastically subverted in a short interval of time. For instance Wallis realized, in the light of a more detailed study, to have misinterpreted the intentions of Gregory and the scope of his result. He thus wrote to John Collins, in November 1668, reproaching Gregory's stubborn attitude:

Mr. Gregory is certainly in the wrong, & therefore I am sorry to see him write at that rate he doth.¹⁰⁴

¹⁰¹In Huygens [1888-1950], vol 6, p. 240. The letter dates from 23 July 1668.

¹⁰²As Gregory protested: "I would certainly like that this very Noble Man will assign me a convergent sequence that, together with its limit, will refute our corollary or, if he cannot find it, I wish only a solid ground for doubting". See Huygens [1888-1950], vol. 6, p. 240. The corollary ('*consectarium*') to which Gregory referred to is the following: "And, conclusively, in order to find the *terminatio* of any convergent sequence, one only needs to find a quantity composed in the same way from the first convergent terms, as from the second convergent terms" (*VCHQ*, p. 24). See also footnote 62 of the present work.

¹⁰³Wallis [2005], p. 544.

¹⁰⁴Wallis to Collins, 3/13 November 1668. In Wallis [2012], p. 23.

Wallis was probably referring also to the preface of *EG*, published at the end of summer 1668, in which Gregory had emphasized his criticism to Huygens and had even resorted to direct attack and name-calling. Thus, in a subsequent letter to Brouncker, from November 1668, he remarked, more precisely:

Supposing all to be true which is demonstrated in his [namely, in Gregory's] 11th proposition (where that demonstration is supposed to ly) it proves no more but that it cannot be performed by his methode; nor that it cannot be done at all; unless it be supposed that the termination of a converging series can be no other way found but by his methode; or, at least, that if it may be found any other way, it may be found this way also; which is not (he sayd) demonstrated.¹⁰⁵

Wallis clearly pointed out that, in order to overcome Huygens' objection, Gregory ought to prove also the converse of proposition X of *VCHQ*: namely, that if the termination of a convergent series is analytical with its terms, it exists an invariant composition, with respect to each convergent term. This would certainly endow the subsequent proposition XI with the required generality.

Despite his subsequent efforts, Gregory did not succeed in giving a satisfactory answer to Huygens' particulari criticism, and failed to change the mind, on the long run, not only of Huygens himself, but also of other recipients who, like Wallis, had initially sided for Gregory's position.¹⁰⁶

Gregory's counter-arguments turned out to be unconvincing in the case of the second main criticism which invested his impossibility claim, and concerned, more specifically, the quadrature of the circle. As I have remarked in the previous section, Gregory seemed to believe, both in *VCHQ* and in *GPU*, that the result proved in proposition XI allowed him to infer the unsolvability of the circle-squaring problem in the classical sense. This belief shone through his correspondence as well, but it was explicitly criticized by both Wallis and Huygens. For instance, disagreeing with Gregory's opinion, Wallis maintained, in a letter to Brouncker from November 1668:

¹⁰⁵Wallis [2012], p. 27. Collins had the same reaction, as we can read in his *résumé* of the controversy (Huygens [1888-1950], vol. 6, p. 372).

¹⁰⁶Thus, in a letter from 12 November 1668, published in the *Journal des Sçavants*, Huygens showed his ultimate and irreconcilable dissatisfaction with Gregory's answers, by commenting: "... tant s'en faut, mesme apres le supplement que Monsieur Gregory a donné à ses demonstrations, que cette impossibilité soit bien prouvée ..." (in Huygens [1888-1950], vol. 6, p. 273).

... That his 11th proposition, though ever so well demonstrated, shews onely yt ye Sector indefinitely considered can not be so compounded as is there sayd: Or, (which is equivalent) not every Sector. Notwithstanding which, it might well enough be possible, that some Sector (if not all) might be Analyticall to its Triangle or Trapezium: (And I think he [namely, Gregory] doth allow it so to bee, or even commensurable).¹⁰⁷

This criticism is exemplified through a analogy with the known case of the trisection of an arbitrary arc. Indeed, as Wallis knew from Descartes' *Géométrie* and Van Schooten's *Appendix de cubicarum aequationum resolutione* (the latter author, in particular, is mentioned by Wallis), the trisection problem can be reduced to an irreducible cubic equation, and therefore, according to Descartes' canon of problem solving, cannot be solved by ruler and compass. There are nevertheless such cases (for instance, the problem of trisecting the angle $\alpha = \pi$) in which the trisection can be reduced to a quadratic equation, and the problem can be therefore solved by ruler and compass. By analogy, Wallis argued that such cases might hold also for special sectors of the circle:

Now if but some one Sector (though not all, or ye Sector indefinitely taken) be found Analytical with his Triangle, or Trapezium; there be many ways, (as, by its proportion to ye whole, by its center of gravity, &c.) by ye help of this one, to square ye whole circle".¹⁰⁸

Huygens adopted a similar critical stance, discussing the impossibility of the analytical quadrature of the whole circle in a letter dated from 12 November 1668 and published in the *Journal des Sçavans* in the same month.¹⁰⁹

Like Wallis before him, Huygens maintained that Gregory's impossibility argument did not allow him to derive any conclusion concerning the ratio between circle and the square built on its diameter:

... il demeure encore incertain si le Cercle et le Quarré de son diametre ne sont pas commensurables, c'est à dire à raison de nombre à nombre; et de mesme en ce qui est d'une portion déterminée de l'Hyperbole, et de sa figure rectiligne inscrite. Pour conclure donc que la raison du Cercle au Quarré de son diametre n'est pas analytique, il falloit demontrer non seulement que le

¹⁰⁷Wallis [2012], p. 29. Also in Huygens [1888-1950], vol. 6 p. 283-4.

¹⁰⁸Wallis [2012], p. 30. Also in Huygens [1888-1950], vol. 6, p. 285.

¹⁰⁹Reproduced in Huygens [1888-1950], vol. 6., p. 292.

Secteur de Cercle n'est pas analytique indéfini à sa figure inscrite, quoique cette démonstration ne laisse pas d'avoir sa beauté; mais que cela est vray aussi in omni casu definito.¹¹⁰

Huygens based his objection on a similar motivation to Wallis' one: he suggested that there might be sectors of the circle holding an analytical, or even a rational proportion with the respective inscribed or circumscribed polygons.¹¹¹ Huygens, like Wallis before him, probably realized that the core of Gregory's impossibility argument consisted in denying the existence of a composition S , invariant with respect to couples of inscribed and circumscribed polygons to any conic sector. But they also realized that one could not infer from the previous result the non-existence of analytically squarable sectors, in the circle, the ellipse and the hyperbola. Possible counterexamples can be easily imagined: for instance, we can think of circular sectors, like those corresponding to the arcs $\varphi = \frac{m}{n\pi}$ (with m, n rational), which are commensurable with the square built on the unitary radius. Therefore, since the impossibility of squaring analytically the circle does not hold true for any given sector, one can doubt whether it is true for those special sectors like the rational submultiples of the circle.

With hindsight, I propose to recast the essential distinction between the impossibility of 'indefinite' and 'definite' quadratures of the circle (resp. of the hyperbola or ellipse), sketched in Huygens' letter, into the following scheme:

- *(Impossibility of the indefinite quadrature)* There is not one analytical composition S , such that for every sector ω of the circle (resp. the hyperbola) and its corresponding inscribed and circumscribed polygons I_0, C_0 , we have that: $S(I_0, C_0) = S(\varpi, \varpi)$.
- *(Impossibility of the definite quadrature)* For every sector ω of the circle (resp. the hyperbola) and its corresponding inscribed and circumscribed polygons I_0 and C_0 , there is not one analytical composition S , such that $S(I_0, C_0) = S(\varpi, \varpi)$.

The different logical structures of the first and the second theorem are for us clear, so that one cannot derive the impossibility of the analytical quadrature of a specific sector solely from the impossibility of the indefinite quadrature. But this distinction might not have been fully clear to the mind of a seventeenth century mathematician. Indeed, only

¹¹⁰Huygens [1888-1950], vol. 6, p. 273.

¹¹¹Huygens [1888-1950], vol. 6, p. 273, 274.

an adequate formalization, certainly not in the purview of early modern geometers, can bring to light the different logical structures of the above theorems.¹¹²

On the contrary, Gregory might have ventured the (incorrect) conjecture that the impossibility of the 'indefinite quadrature' of the circle entailed the impossibility of the 'definite' one, deriving from it the (true, but incorrectly proven) conclusion that the quadrature of the whole central conic could not be solved analytically.

The demarcation, introduced in the above passage, between proving the impossibility of the quadrature of a conic "indefinitely" and "in every definite case" may represent a first formulation of the distinction between the inquiry into a general resolutive formula S , which allows one to square any arbitrary sector of a conic section (that we may call, following the example of Huygens and Wallis, 'indefinite' quadrature), and the inquiry for the quadrature of a particular sector (namely, the 'definite' quadrature) which entered into successive mathematical practice and became current from the second half of XVIIth century on.¹¹³

In his response to Huygens, contained in a letter addressed to the *Transactions of the Royal Society* from 25th December 1668 (published in the *Philosophical Transactions* of 15th February 1669 No. 44), Gregory did not recognize the relevance of the distinction into indefinite/definite quadratures, and continued to argue that his impossibility argument held for every "definite case", included the case of the whole circle.¹¹⁴

¹¹²As observed by Pourciau, with respect to an analogous problem concerning the integrability of ovals, in which existential and universal quantifiers appear with the same functions as in the cases examined here: "But in the mathematical work of an earlier era, such as the 17th century, it can be difficult to decide what a given proposition or lemma actually asserts or was intended to assert. The statement may contain words that have unclear definitions, there may be implicit assumptions that do not appear in the statement but which would have been taken for granted by the author, and there may be a vague use of quantifiers leading to an ambiguous logical structure" (Pourciau [2001], p. 481).

¹¹³Thus, a text like Montucla's *Histoire des recherches sur la quadrature du cercle* (1765) presents this distinction as an acquired fact: "Les géomètres distinguent deux manières de carrer les courbes, bien inégales en perfection; ils nomment l'une définie, l'autre indéfinie. En appliquant ceci à l'objet présent, la quadrature définie du cercle serait la mesure de son aire, ou entière, ou seulement de quelque segment déterminé (...) si quelque methode donnait en général la quadrature d'un segment quelconque (...) on aurait la quadrature indéfinie du cercle (...) pour passer de la quadrature définie du cercle à celle de ses parties quelconques, il resterait à résoudre ce problème, plus difficile que le premier: *trouver la raison de deux arcs dont on connaîtrait le sinus ou les tangentes*." Montucla [1831], p. 28.

¹¹⁴"Ne tamen ullus reliquatur cavillationi locus, 11mam nostram *Propositionem* etiam *in definitis* hic demonstrabimus" (Huygens [1888-1950], vol. 6, p. 308, also in Gregory [1939], p. 52, 64-65: "... in order to leave no place for sophistries, we will prove our proposition XI also in definite cases").

However, Gregory's argument in defence of the charge that he had proved solely the impossibility of the 'indefinite' quadrature of the circle is inadequate and "predestined to fail", as pointed out in Dehn and Hellinger [1943].¹¹⁵ Gregory treats, in the letter from February 1669, the case of the (definite) quadrature of the whole circle with the aid of the result obtained for the indefinite case. Thus, he argues, if we assumed that an analytical composition S existed, such that the following algebraic equation held: $S(x, a) = S(\varpi, \varpi)$, in the unknown x (' x ' and ' a ' denote an inscribed and a circumscribed polygon to a given sector, like the quarter of a circle, while ' ϖ ', the termination, denotes the sector itself), then the same algebraic equation must also hold for any couple of inscribed and circumscribed polygons (all expressible in terms of x and a). Therefore, Gregory concludes, the equation: $S(x, a) = S(\varpi, \varpi)$ cannot have a fixed finite degree, which involves a contradiction with the previous suppositions. Independently from its correctness, this argument establishes only that no analytical composition S satisfying the previous conditions exists, but it does not imply that the area of a definite sector (for instance, the quarter of a circle) is not analytical with the inscribed and circumscribed polygons.¹¹⁶

Yet Gregory could have taken the easier step to study those sectors squarable analytically, in order to inquire for their common feature and exclude, on this ground, the rational sectors of the circle (and therefore the circle itself) as lacking such characteristics proper to analytical sectors. This argument may not yield a rigorous proof that the circle cannot be squared analytically, but it could have offered a ground for conjecturing such an impossibility.

If A is the area of a circle with circumference c and radius r , we shall have, in virtue of Archimedes' first proposition of the *Dimensio circuli*: $A = \frac{cr}{2}$. On this ground, we can characterize sectors that are analytical with the square built on the radius: these will be all sectors whose area is a rational multiple of the arc-length $\frac{1}{c}$ (namely $\frac{m}{nc}$, where m and n are rational numbers) and more generally all sectors whose area is an irrational algebraic multiple of $\frac{1}{c}$, namely $\frac{\alpha}{c}$.

Such a characterization of the squarable sectors in a circle calls for the following observations. Firstly, one can remark that these sectors cannot be constructed, unless one

¹¹⁵ [Gregory, 1939], p. 476.

¹¹⁶ Dehn and Hellinger advance an obvious counterexample against Gregory's reasoning. It is in fact sufficient to consider a transcendental function like $\sin \frac{\pi}{2}x$. The equation: $\sin \frac{\pi}{2}x = 1$, indeed, admits infinite solutions (namely $x = 1, 5, 9 \dots$), although they are all 'analytical'.

knows how to construct a sector of area: $\frac{1}{c}$, which depends on the determination of c . Therefore, even if it is true that analytic sectors (with respect to the square built on the radius) exist, one may object that these sectors, at least those we can identify in principle, cannot be exhibited through elementary constructions. This reasoning seems to be within the purview of an early modern mathematician, and might have been employed by Gregory as a reply against Huygens' (and Wallis') claim to the existence of squarable sectors, although I could not find such a critique explicit among Gregory's arguments.

My second remark concerns more properly the core question dealt with by Gregory: the possibility of expressing the area of the circle by a finite combination of arithmetic operations in terms of the inscribed triangle and the circumscribed quadrilateral or, equivalently in terms of the square built on the radius. We have shown above that there exists infinite sectors of the circle analytical with the square on the radius. With hindsight, we recognize that these sectors represent a countable infinity (indeed the set of algebraic numbers is countable). We might venture the following conjecture: among circular sectors, those we can recognize as analytical are very rare, so that the rational sectors of the circle, among which we count the whole circle too, will have a higher probability to fall into the class of sectors that cannot be analytically squared.

This is not an argument for the impossibility of the definite quadrature of the whole circle, but could have offered the ground for conjecturing such impossibility. If a rigorous distinction between countable and uncountable sets was not in Gregory's purview, he might have intuited that analytical sectors are somewhat 'special' sectors within the circle. In order to clarify the meaning of 'special', I underline an analogy with a similar phenomenon, discussed by Descartes: the constructible points on a mechanical curve, like the quadratrix. Let us recall that by means of such procedures as Clavius' ruler-and compass construction of the points on a quadratrix (explored in chapter 5, sec. 5.2.3 of this study) infinitely many points are constructible on the curve, although not any point, arbitrarily chosen, can be constructed by a geometric procedure: in this sense, the quadratrix is constructible, although only in a 'special' way. Analogously, Gregory might have hypothesized that infinitely many squarable sectors could be discovered (these are all the rational multiples of the sector measuring $\frac{1}{\pi}$), but not any sector, arbitrarily chosen, could be squared. However, these remarks shall remain, so far, on the level of conjectures, since no considerations of this kind can be found among Gregory's extant responses.

At any rate, Gregory's reply did not persuade either Huygens or Wallis, who declared themselves dissatisfied with the central points of Gregory's response and, in front of the latter's obstinate defense, abandoned the controversy.¹¹⁷

When the dispute finally closed off by the beginning of 1669, Gregory had not accepted either one of the two main criticisms advanced against his impossibility claim. On the contrary, he persisted in his opinion that proposition XI of *VCHQ* proved the impossibility of the analytical quadrature of an arbitrary sector of a conic and of the whole circle too, without adding new evidence for his claim, and barely concerned by the negative reactions of his correspondents.¹¹⁸

The end of the controversy might have been sanctioned either by political and sociological reasons and by mathematical ones. Concerning the first reasons, Gregory's vehement reactions towards Wallis and especially towards Huygens, who enjoyed a high consideration as a foreign member of the Royal Society, certainly damaged Gregory's reputation and led other members of the Society, included those who had initially supported Gregory, to officially take a stance against him and refuse to concede their main publication, the "Philosophical transactions of the Royal Society", as a resonating chamber for Gregory's and Huygens' controversy.¹¹⁹

However, the controversy had also reached, in the turn of few months, a real mathematical *impasse*. As I have argued, Wallis' and Huygens' objections are mathematically sound:

¹¹⁷This is witnessed, for instance, by Wallis' eloquent letter to Oldenburg, from 7 nov. 1668: "As for Mr. Gregory, I do not mean to trouble myself farther with him. I am onely sorry that I have, upon his importunity, taken so much pains to displease him. Yet, after all his ranting, he is certainly in an error; for what he does pretend to neither is by him demonstrated, nor can it (his way) bee done. But he is not capable of being advised, and therefore must take his course." (in Scriba, vol III, p. 37. See also the same work, p. 23). Huygens' ultimate opinion was on a similar tone. In a letter from March 1669 to Robert Moray, one of Gregory's friends and supporters, had eventually dismissed Gregory's reply: "... la derniere response de Monsieur Gregory sur le sujet de la Quadrature, ou il n'a rien fait qui vaille, et je voudrois bien scavoir s'il y a aucun des geometres par de la qui prenne pour des demonstrations ce qu'il donne pour telles. J'ay de la peine a m'imaginer qu'il le croye luy mesme, et il me paroît plus vraysemblable qu'il s'est voulu sauver dans l'embaras et dans l'obscurité" (in Huygens [1888-1950], vol. 6, p. 396).

¹¹⁸In February 1669, for instance, Gregory even declared to have "nothing to reply" to Wallis' criticism, as he judged it incomprehensible in the light of the principles of geometry and analysis (Gregory [1939], p. 68). Moreover, Gregory continued to express his disagreement with Huygens still in 1670: "I do not know (neither do I desire to know) who calleth (...) Hugenius his animadversions of Nov. 12 1668, judicious, but I would earnestly desire tha he would particularize (if he be not an ignorant) in what my answer, which is contradictory to Hugenius his animadversions, is faulty..." (In Gregory [1939], p. 77).

¹¹⁹The consequences of Gregory's poor diplomatic skills over the conclusion of the controversy, and the abrupt turn taken by his career are examined in Antoni Malet's phd dissertation, especially page 39 and sq.

taken at their face value, neither Gregory's arguments nor its further elucidations seem sufficient in order to prove the impossibility of the analytical quadrature and properly respond to the objections.

On the contrary, it is apparent from Huygens and Wallis' reactions (who were the most outstanding mathematical recipients of Gregory's ideas) that the moves of Gregory had the opposite effect of entangling the discussion instead of clarifying it. This is, at least, what we evince from Huygens' considerations in a letter to Oldenburg, from 30/03/1669: "Il me semble par la response de Monsieur Gregory qu'il s'est trouvé fort embarrassé de mes derniers instances, car au lieu d'y respondre pertinemment, il ne cherche qu'à embrouiller tellement la dispute, et la rendre si obscure que personne n'y comprendra dorenavant rien".¹²⁰

A predictable consequence of this situation was probably a general loss of interest in the controversy, and its eventual abandonment, since no advance or change appeared either on Gregory's side or on the side of his critics, to the effect that the whole debate ought to appear rather sterile to its readers.

The criticism so far examined made it clear that Gregory's reasoning relied on implicit and unjustified assumptions, although it did not imply the falsity of his impossibility claims. Wallis was certainly aware of this, as he detailed it in his account. Indeed, in his letter to Brouncker from 14 November 1668, he qualified his objections to Gregory as 'Objections against his Demonstration' instead of objections against his own 'doctrine'. In other words, Wallis sympathized for Gregory's 'doctrine', that is, for his belief on the impossibility of squaring the circle analytically, "having many years since demonstrated the same (...) though he [namely Gregory] take no notice of it, in my *Arithmetica Infinitorum*, propositio 190 with ye Scholium annexed".¹²¹

¹²⁰In Huygens [1888-1950], vol. 6, p. 391. "La response de M. Gregory" to which Huygens refers to is obviously the last letter published in the *Transactions* in February 1669.

¹²¹Huygens [1888-1950], vol. 6, p. 288. The reference is to the commentary to proposition 190 of *Arithmetica Infinitorum*, where Wallis explained: "And indeed I am inclined to believe (what from the beginning I suspected) that this ratio we seek is such that it cannot be forced out in numbers according to any method of notation so far accepted, not even by surds (...) so that it seems necessary to introduce another method of explaining a ratio of this kind than by true numbers or even by the accepted means of surds" (Wallis [2004], p. 161). The case dealt with by Wallis concerns the quadrature for the definite case of the circle, as it is stressed in the same letter to Brouncker: "...in my *Arithmetica Infinitorum*; proposition 190. with ye Scholium annexed to it. Where it is proved, that what was before demonstrated to be ye true proportion between ye Circle & ye Square of its Diameter or Radius, or between ye Diameter & ye Perimeter; cannot be expressed either by Rational Numbers or Surd Rootes (or, as this Author speaks, is not Analytically)" (Huygens [1888-1950], vol. 6, p. 289).

On the other hand, Huygens entertained a different belief concerning the nature of the circle-squaring problem. Not only he refused to accept the validity of Gregory's argument in order to prove his impossibility claims, but he believed that the circle-squaring problem in its traditional meaning (namely, the problem of constructing a square equal to the whole sector of the circle) was solvable either by ruler and compass, or by one of the acceptable curves in cartesian geometry.

His idea is motivated firstly on pragmatical grounds: "La recherche de la Quadrature du Cercle - he explained in his letter from 12 November 1668 - a fait trouver tant de belles choses aux Geometres, qu'afin qu'ils ne soient pas privez d'un exercice si utile, je suis d'avis de defendre contre Monsieur Gregory la possibilité d'y reüssir" (Huygens [1888-1950], vol. 6, p. 272). Huygens was possibly thinking that the circle-squaring problem was a 'fruitful' problem, in the sense that it had been and would be the source of numerous discoveries. We can suppose that Huygens had in mind his own work *De Circuli Magnitudine Inventa*, in which he improved the Archimedean approximation techniques in order to compute the area of the circle: even if he did not find a geometric quadrature, such an hope might have been one of the leading motives of his research.

We can also recognize, acting as a broad methodological motivation in the backdrop of this critique, a rather traditional refusal to accept a negative outcome of a problem as a meaningful solution at all, which complies with Huygens' style and practice of doing mathematics. As Scriba put it, perhaps in too sharp but fundamentally correct terms: "the Dutch mathematician was a geometer, not an analyst. Huygens mastered the classical methods in a superb way but never really grasped the new analytical methods of the calculus; he was a traditionalist in the best sense of the word, emphasizing the beauty and exactness of the classical methods".¹²²

However, despite his confidence that the ratio between a circle and the square built on its diameter might still be a rational or surd number, Huygens convincingly argued only about the inadequacy of Gregory's impossibility arguments, but did not advance any ultimate objection in order to debunk Gregory's impossibility claim. In particular, when he tried to show its inconsistency, he came up with faulty arguments.¹²³

¹²²[Scriba, 1983], p. 283.

¹²³Huygens' fallacious argument is discussed and dismissed in Dijksterhuis [1939], p. 483, in Scriba [1957], in particular p. 18.

Consequently, when the controversy reached an end, Huygens could not deploy any 'killer' argument to debunk Gregory's impossibility claim. This outcome shows that the main issue of the controversy, concerning the algebraic or analytical quadrability of the circle, remained unsolved by the beginning of 1669. I surmise that this unsatisfactory ending is one of the driving forces which motivate, still three or four years after, the interest shown by Huygens for Leibniz's treatise *De Quadratura arithmetica circuli ellipseos et hyperbolae cujus corollarium est trigonometria sine tabulis*, and the impossibility arguments which can be found in this work.

I will discuss these topics with more detail in the next chapter, in order to argue, against [Dijksterhuis, 1939] in particular, that this controversy did not remain inconclusive, at least from an historical point of view.

7.6 Conclusions

Gregory's statement on the impossibility of finding an analytical solution to the quadrature of the circle or of the other central conic sections entailed a negative answer to the question raised in the preface of *VCHQ*: is Descartes' problem solving strategy, relying on the five arithmetical operations introduced in the first book of *La Géométrie* (analytical operations in the language of *VCHQ*), endowed with sufficient generality in order to express any kind of proportions among quantities?

In the previous chapter, I have argued that a distinction between possible and impossible problems could be made in the framework of Descartes' geometry: the first ones, but not the second, being reducible to a finite algebraic equation. Descartes did not offer a proof, however, that a problem like the squaring of the circle could not be solved: his claims were based on a mixture of opinions transmitted by tradition and of personal convictions.

As we have examined in this chapter, Gregory offered a tentative proof for Descartes' guess by reducing the problem of the quadrature of the circle (generalized to the quadrature of conic sectors) to its analytical counterpart. This reduction could be obtained by employing the symbolism of the algebra of segments to denote areas, which makes also possible the use of convergent series in order to reduce the problem of quadrature to a problem concerning the computation of the limit of a convergent sequence, namely a problem of algebra, as far as the limit *t* (*terminatio*) of a sequence might be found as a

solution of the finite polynomial equation in the form: $f(t, t) = f(a_0, b_0)$, with $\{a_0, b_0\}$ taken as initial term of the sequence.

Gregory assumed that the problem of squaring the central conic sections was solvable by cartesian tools, and turned to a proof of impossibility once he had gained the presumption that the area of the sector was not analytical with given polygonal areas of rational measure.¹²⁴ This approach, I surmise, shaped the structure and the scope of his proof of impossibility: Gregory's argument remained clothed in a geometric vest, so to speak, and, as pointed out by Huygens' critique, it depended on the construction procedure employed for obtaining the polygonal approximations to the sector, lacking therefore the desired generality.

On the other hand, though, I suggest that the impossibility result stated in *VCHQ* has a role that might be called as "metatheoretical", as far as it was seen by Gregory as playing a structural and methodological role for the constitution of algebra and geometry.

In his view, in fact, the impossibility of solving a problem (like the squaring of the circle) by a given established methodology (like the method prescribed by cartesian analysis and synthesis) was not only a result analysis should accomplish, but it had the fundamental consequence of promoting the extension of mathematical entities and thus redesigning the disciplinary boundaries of geometry by adding new constructions, new arithmetical operations and finally new quantities to the already existent ones.

Let us reconsider, for instance, the content of proposition XI of *VCHQ*, largely discussed in the previous sections. One way to understand it would be by saying that the limit of the convergent sequence $\{I_n, C_n\}$ does not exist within the space of analytical quantities, although it denotes a geometric magnitude, namely a magnitude that we can represent by a construction and whose area can be measured.

We may therefore ask whether a new operation can be conceived, that allows us to attain such a geometric, non-analytical quantity starting from given analytical ones. It seems, from the scant remarks offered in *VCHQ*, that Gregory pondered the questions, and suggested that the infinite succession of operations which engendered the sequence itself might stand as a "sixth operation", namely an operation - he explained in the preface of *VCHQ*, anticipating the main result of his work - whose nature is infinite and does not

¹²⁴ *VCHQ*, p. 5.

coincide with any finite combination of the 5 arithmetic operations, although it could be applied to them in order to yield non-analytical quantities.¹²⁵

Gregory argued that the ampliation of known operations with new ones, which appears as a consequence of an impossibility result of the kind proved in the *VCHQ*, was a phenomenon somehow germane to the development of geometry and arithmetic. A case at point is represented by irrational quantities or numbers (namely ‘surd’ quantities, or quantities obtained from rational ones by root extraction). In fact, Gregory saw an analogy between the extension of the commensurable quantities by means of the operation of root extraction to include incommensurable ones, and the extension of analytical quantities by means of a new species of non analytical quantities, obtained by the “sixth operation”. Thus, we read in the preface of *VCHQ*:

Advertendum quoque est sicut numeri fracti nunquam procedunt ex commensurabilium additione, subductione, multiplicatione, divisione, sed tantum ex radicum extractione; ita numeros, vel quantitates non analyticas numquam provenire ex analyticarum additione, subductione, multiplicatione, divisione, radicum extractione, sed ex sexta hac operatione, ita ut haec nostra inventio addat arithmeticae aliam operationem, et geometriae aliam rationis speciem.¹²⁶

Gregory had plausibly in mind the traditional result on incommensurability between the diagonal and the side of the square. It should be pointed out that for XVIIth century mathematicians, the traditional incommensurability proof ought to be interpreted differently than in antiquity. Indeed, the Greeks could not conceive of a number expressing the ratio between the diagonal and the side of a square. As A. Szabó argues, in his Szabó [1978], the proof of incommensurability did not lead ancient mathematicians to derive the existence of such a ratio as a number, but rather to shift the approach to the problem from arithmetic to geometry and eliminate what was regarded as an insoluble question.

On the contrary, Gregory, and presumably his contemporaries too, admitted irrational numbers as arithmetical entities, and recognized that these entities could not be obtained

¹²⁵ *VCHQ*, p. 7.

¹²⁶ "It must be remarked that just like surd numbers are never obtained from the addition, subtraction, multiplication, division of commensurable quantities, but only from the extraction of roots; so numbers or non analytical quantities are never obtained from the addition, subtraction, multiplication, divisions, extraction of root of analytical quantities, but from this sixth operation, so that our invention adds another arithmetical operation, and another kind of ratio", *VCHQ*, p. 5.

from any finite combination of additions, subtractions multiplications or divisions of rational quantities. In analogy with incommensurable quantities and irrational numbers, Gregory held that non-analytical quantities and numbers, like the ratio between the circle and the square built on its diameter, could be expressed solely by extending the known arithmetical operations with a 'sixth' non analytical operation that applied to analytical quantities could yield a non-analytical quantity as a result.

The similarity between the case of root extraction and the one of the sixth operation suggests what role impossibility results might have played in Gregory's view about the architecture of mathematics: an impossibility result would eventually prompt the extension of a given domain in geometry or arithmetics by means of new objects and new operations.

In the preface of *VCHQ*, Gregory deployed a theoretical classification of operations loosely grounded on this view:

ex illis quinque operationibus arithmetis, duae sunt tantum simplices, additio & subtractio, multiplicatio est composita ex additione, & divisio ex subtractione, et extractio radicum, quae in genere nihil aliud est quam inventio proportionis commensurabilis, quae quam proxime accedit ad proportionem analyticam incommensurabilem, componitur ex praecedentis quatuor, & nostra sexta operatio, quae in genere nihil aliud est quam inventio proportionis commensurabilis quam proxime accedentis ad nostram proportionem non analyticam, componitur ex prioribus quinque.¹²⁷

Gregory defined the arithmetical operations genetically, starting from what he considered the simplest ones: addition and subtraction. Multiplication and division were thence conceived as composed from the iteration of the previous operations,¹²⁸ whereas the

¹²⁷*VCHQ*, p. 5. "Out of these five arithmetical operations only two are simple, addition and subtraction; multiplication is composed from addition, and division from subtraction; and the extraction of roots, which, in general, is nothing else than the invention of a commensurable proportion, which approximates the most closely an incommensurable analytical proportion, is composed out of the four previous operations; and our sixth operation, which in general is nothing but the invention of a commensurable proportion, which approximates the most closely our non analytical proportion, is composed out of the previous five operations".

¹²⁸Multiplication might have been interpreted as an iterated addition, in the sense that: $a \times b = a + a + a + \dots b$ times. On the other hand, Gregory might have in mind an algorithm for division between integers similar to Euclid's one (see *Elements*, VII,1). Thus, given two numbers a, b , such that $a > b$: $a \div b = q$ can be read as the repeated subtraction: $a - b - b - b \dots q$ times. The subtraction stops either when it reaches 0, or a number $r < b$. The operation of division can be extended also to the

extraction of roots was characterized as the construction of a rational number sequence, or a sequence of proportions holding among commensurable quantities approximating a given incommensurable one.

The structural role of impossibility results emerges in particular concerning the introduction of irrational and non-analytical quantities, together with their corresponding operations of root-extraction and with the 'sixth non analytical operation'. As we know, in fact, in the same way that a quantity a incommensurable to a given quantity b can be represented by an infinite sequence of commensurable quantities, which tend to a , a quantity ϖ proved to be non analytical with a given quantity e , can be represented as the limit of a sequence of analytical quantities with e .

Eventually, Gregory intended the operation of root extraction as a shorthand for the construction of an infinite sequence of rational numbers or commensurable quantities approximating an irrational number or an incommensurable quantity, and identified his so-called 'sixth operation' with the construction of a convergent sequence of analytical quantities or numbers tending to a non-analytical one.¹²⁹

Echoes of this view resonate in some of Wallis' considerations to be found, for instance, in his *Arithmetica Infinitorum* (1656), on the role played by impossibility results in the extension of mathematics.¹³⁰

In the *Arithmetica infinitorum*, Wallis proposed to apply to geometry, and particularly to the problem of determining the ratio between a circle and the square built on its diameter, the same kind of reasoning that he saw applied in arithmetic, where new entities are introduced "when some impossibility is arrived at, which indeed must be

case $a < b$ via the introduction of rational numbers or fractions, but Gregory does not enter into these details.

¹²⁹ *VCHQ*, p. 29. Dehn and Hellinger propose an original interpretation of this "sixth operation" (Gregory [1939], p. 470), and suppose that Gregory did envisage to prove, in his proposition XI, the existence of a (sixth) non-analytical composition S , such that: $S(I_0, C_0) = S(I_1, C_1) = S(\sqrt{I_0 C_0}, \frac{2I_0 C_0}{I_0 + \sqrt{I_0 C_0}})$. It is true that we can identify S with a non-analytical operation (as we know, Dehn and Hellinger work out one such example) but it is at least debatable whether Gregory intended to prove the existence of a non-analytic function, instead of the more likely claim on the non-existence of analytical compositions which may allow him to compute the limit. Conclusively, since no explicit statement from Gregory's side supports this interpretation and a precise characterization of this sixth non analytical operation is definitely lacking in Gregory's narration, Dehn and Hellinger's interpretation, although suggestive, remains far-fetched.

¹³⁰ Panza [2005], p. 75-78, Stedall [2002], p. 181-183.

assumed to be done, but nevertheless cannot actually be done".¹³¹

In this case, Wallis argues, arithmeticians "consider some method of representing what is assumed to be done, though it may not be done in reality",¹³² for instance by introducing a new symbol standing for the solution of an equation of the form: $a + C = b$ when $a < b$ (for instance when a number x is required, such that $3 + x = 2$), or or by introducing a symbol standing for the solution of an equation of the form: $a \times C = b$ when a is not its perfect divisor of b (for instance, in the case of the solution to the equation: $3x = 2$), or else, in the case of the introduction of irrational numbers, when we look for a number whose square yields a given natural number, which is not a perfect square (for instance, when we want to find a number x such that $x^2 = 12$).¹³³

In Wallis' view, finding the expression of the ratio between a circle and the square constructed on its diameter was a similar problem, which could be solved by a likewise procedure. According to his conjecture, in fact, the number π could not be expressed by a known rational or irrational number. Therefore, it must be expressed by a new kind of number, expressible through a new symbol:

quoties autem hoc contingint, cum illud veris numeris designari non possit (& ne quidem solis radicibus surdis) quaerendus erit modus aliquis id ipsum utcumque exprimendi. Si igitur ut $\sqrt{3 \times 6}$ significat terminum medium inter 3 et 6 in progressionem Geometricam aequabili 3,6,12, &c. (continue multiplicando $3 \times 2 \times 2$ &c.) ita $\mathfrak{M} : 1 \mid \frac{3}{2}$: significet terminum medium inter 1 & $\frac{3}{2}$ progressionem geometricam decrescentem 1, $\frac{3}{2}$, $\frac{15}{8}$, &c. (continue multiplicando $1 \times \frac{3}{2} \times \frac{5}{4}$ &c.) erit $\square = \mathfrak{M} : 1 \mid \frac{3}{2}$: Et propterea circulus est ad quadratum diametri, ut 1 ad $\mathfrak{M} : 1 \mid \frac{3}{2}$. Quae quidem erit vera circuli quadratura in numeris, quatenus ipsa numerorum patitur, explicata.¹³⁴

¹³¹Wallis [2004], p. 162.

¹³²Wallis [2004], p. 162.

¹³³Wallis [2004], p. 162.

¹³⁴Wallis, *Arithmetica Infinitorum*, proposition CLXXXX, scholium 175. "As much, moreover, holds here; since it is not possible to designate that quantity (\square) by a true number (not even by the usual said radicals, or surds), as $\sqrt{3 \times 6}$ signifies *the mean term between 3 and 6 in a regular geometric progression 3, 6, 12, etc.* (from the continued multiplication $3 \times 2 \times 2$ etc.) so $\mathfrak{M}(1 \mid \frac{3}{2})$ signifies the mean term between 1 and $\frac{3}{2}$ in a decreasing hypergeometric progression (from the continued multiplication $1 \times \frac{3}{2} \times \frac{5}{4}$ etc.) which will be $\square = \mathfrak{M}(1 \mid \frac{3}{2})$. And therefore the circle, to the square of its diameter, is as 1 to $\mathfrak{M}(1 \mid \frac{3}{2})$. Which indeed is the true Quadrature of the Circle expressed in numbers, as far as the nature of those numbers may be shown" (translation in Wallis [2004]).

It is not known whether Gregory had knowledge of Wallis' work before 1667, but certainly his own research differed from Wallis', starting from his approach to the circle-squaring problem based on finite approximation techniques rather than infinitesimal ones. It is certain, on the other hand, that Wallis saw the extant similarities between his conception of impossibility results in mathematics and Gregory's ideas.¹³⁵

At their basis, both mathematicians shared similar ideas concerning progress of mathematics, achievable through the introduction of new symbols and operations. In particular, Gregory explicitly connected this research to a critique of cartesian geometry, and in particular of the analytical method there applied.

Concerning the critique of cartesian geometry, explicit in Gregory's treatise, we can ask whether and in which ways the very separation between geometry and mechanics underwent any modifications caused by the enrichment of the domain of mathematical entities after the introduction of non-analytical compositions and quantities. This concern was effectively present to Gregory, as we can read in the last *Scholium* of *VCHQ*:

multa talia problemata possem hic resolvere ope analysisios & nostrae serierum convergentium doctrinae, quae antea impossibilia aestimabantur: sed dicet forte aliquis has resolutiones non esse geometricas; respondeo, si per geometricum intelligatur praxis ope solius regulae & circini peracta, hanc in his non solum esse impossibilem sed etiam in omnibus problematis quae ad aequationem quadraticam reduci non possunt, sicut facile demonstrari posset; & si per geometricum intelligatur reductio problematis ad aequationem analyticam, omnia haec problemata sunt geometricè impossibilia, cum ex hic demonstratis, manifestum sit talem reductionem fieri non posse: si vero per geometricum intelligatur methodus omnium possibilium simplicissima; invenietur fortasse post maturam considerationem omnia praedicta problemata esse geometricissime resoluta.¹³⁶

¹³⁵Huygens [1888-1950], vol. 6, p. 234.

¹³⁶*VCHQ*, p. 58: "By means of the analysis and of our doctrine of convergent series I can solve many of those problems, that before were judged impossible. However, one may perchance object that these solutions are not geometrical. I answer, that if one understands by geometrical the praxis requiring the sole aid of the ruler and compass, not only these problems will be impossible, but even all the other problems which cannot be reduced to quadratic equations, as it could be easily proved. If, by geometrical, one understands the reduction of a problem to an analytical equation, all these problems are geometrically impossible, as it is manifest, from the results proved here, that this reduction cannot be done. However, if by geometrical one understands the simplest of all possible methods; it may discover, after mature consideration, that all the said problems are solved in the most geometrical way".

Gregory was aware that the boundaries of geometry may vary according to the choice of the solving means adopted. Preference for one view or the other could be argued on mathematical grounds, but the decision about what should be considered "mathematically proper" still remained a matter of methodological or meta-theoretical choice.

Therefore, one could adhere to the euclidean norm and identify geometricity with solvability by ruler and compass (a move adopted, in early modern period, by Viète in his *Apollonius Gallus*), or else extend, like Descartes did, geometry to include all problems reducible to analytical equations. To these criteria, Gregory added a third criterion of geometricity: the fact of being geometrical is a property of the solution to a problem, which obtains when the problem has been solved by the simplest method.

This third criterion allows one to identify the content of geometry with a property of solutions - namely simplicity - rather than with a domain of objects (curves or problems). Therefore, provided a method for deciding the simplest solution for a given problem, there would be no sound mathematical question which is in principle excluded from geometry.

These considerations lead me to approach here the second significant role impossibility proofs might play in Gregory's mathematical practice. I argue, indeed, that proving that the quadrature of the circle could not be solved analytically did not imply, for Gregory, that this problem admitted no solution at all in geometry.

This point is made clearer in the preface of the *Geometriae pars universalis* (*GPU*) where the author remarks, responding to some criticism advanced against proposition XI of *VCHQ* (criticism of unknown origin, as far as i could ascertain, as they are discussed several months before Wallis' and Huygens' objections):

primo obiicitur contra titulum, nempe tractatum meum male appellari vera circuli et hyperbolae quadraturam, cum potius sit conatus demonstrandi illam esse impossibilem, respondeo, si esset impossibilis, nulla daretur proportio inter circulum et diametri quadratum, et ideo falsa esset 5 definitio lib. 5 Euclidis. . .¹³⁷

¹³⁷ "At first, they objected against my title, namely that it is wrongly called '*vera circuli et hyperbolae quadratura*', since it is rather attempted to prove that the quadrature is impossible. I answer that, if it were impossible, no proportion would be given between the circle and the square of its diameter, and therefore the fifth definition of Euclid's book V would be false". *GPU*, p. 5.

The criticism mentioned by Gregory seems to point to the very title of his work: *Vera circuli et hyperbolae quadratura*. According to this objection (whose author is not mentioned), we may not admit a 'true' and in the meantime 'impossible' solution to a problem, as Gregory claims right from the title of his work. In his explanation, Gregory makes more precise his understanding of the term 'impossible'. Gregory explains that we should not understand the impossibility of solving the quadrature of the circle as implying that no proportion exists between the circle and the square on its diameter. Indeed, if no such proportion existed, then the fifth definition in Euclid's Book V would be violated.

Gregory is probably referring, in his explanation, to the definition 5 in Clavius' edition of the elements, namely: "rationem habere inter se dicuntur, quae possunt multiplicare sese mutuo superare".¹³⁸ But a circle and the square are obviously quantities that can 'exceed one another'. On this basis, Gregory could assert the existence of a 'true' geometrical quadrature of the circle, "discovered and proved in its own kind of proportion", as the subtitle of *VCHQ* recites, but a quadrature which cannot be tackled by analytical means. Just like Descartes did, with respect to the quadrature of the circle (*cf.* ch. 6), so Gregory stressed that the impossibility of solving the problem of squaring the circle, and the other conic sections did not entail that a solution did not exist, but entailed that a solution could not be reached, by means of analytical methods.¹³⁹

¹³⁸This definition corresponds, in Heath's edition, which follows the text established by Heiberg, to df. 4 of Book V: "Magnitudes are said to have a ratio to one another which are capable, when multiplied, to exceed one another". This definition can be seen to state a condition of homogeneity between two quantities x, y . Hence x will be homogeneous to y iff it exists a number m such that $mx > y$ and it exists a number n such that $ny > x$, where the relation '>' can be read as ' x is greater than y '.

¹³⁹On this concern, we read in the *Geometriae Pars Universalis* that Gregory was persuaded by the very analytical impossibility of the squaring of the central conic sections, argued in the *VCHQ*, to reorganize the disciplinary field of geometry beyond the bounds of Descartes. Gregory indeed claimed, in the preface of the *GPU*, that the weakness of the analytical method (based, in his words, on the "examination of unknown quantities" and on their subsequent reduction to algebraic "equations with known quantities") appears mainly in the "measurement of curvilinear quantities" (*cf.* *GPU*, p. 3). He thus proposed to remedy ("*suppleri*") the deficiencies of cartesian analysis by emphasizing the role of geometrical transformations as an essential tool to deal with quadratures. From Gregory's viewpoint, quadratures could be solved: "Si modo e data cujuscumque figurae proprietate essentiali, daretur methodus eam transmutandi in aliam aequalem cognitae proprietates habentem, et huius in aliam, et sic deinceps, donec tandem transmutatio fiat in aliquam quantitatem cognitam, sic enim exhiberentur quantitatis propositae mensura quaesita, non secus quam in aequationis analyticae resolutione" (In Malet [1996], p. 64: "Provided that, knowing the essential property of any given figure, a method were given to transform (*transmutandi*) the figure in an equal one having known properties, and then [to transform] this latter figure in another, and so forth, until eventually the figure is transformed in some known quantity, in this way the sought-for measure of the given quantity would be found, not differently from what is done in the resolution of analytical equations"). A theorem of transformation established the equality between a figure A and a figure B , once B has been obtained from A through a geometric transformation. I note that the same method adopted by Gregory in order to transform figures in order to facilitate their quadrature, lies at the ground of Leibniz's transmutation theorem that we have discussed in the previous

The third meaning of 'geometrical' introduced in the above passage as "the simplest method among the possible ones" may also characterize, for Gregory, the solutions to a problem like the squaring of a central conic. By assessing that there cannot be any solutions obtained through the construction of finite algebraic equations, Gregory eventually established that there could not be a class of simpler solutions than the ones obtained by sequences approaching non-analytical quantities (and therefore, by approximation methods as the one studied by Gregory himself in *VCHQ*), or by such mechanical curves like the spiral and the quadratrix.¹⁴⁰ Consequently, this kind of solution, being the simplest one according to the impossibility argument given in *VCHQ*, would also be the most geometrical one, according to the third meaning of geometricity detailed above.

Gregory might have conceived an ideal process of development of geometry by adding new methods of solution, parallel to the one that he (and Wallis) saw in the development of arithmetic by new operations. In this sense, a proof or an argument establishing the impossibility of solving a problem by a given set of solving methods¹⁴¹ justified the addition of new solving means, and rendered therefore untenable the identification of geometry with a fixed domain of objects or problems.

chapter, and was probably a source of inspiration for it. Although Gregory's demonstrations offered in the *GPU* are all worked out in a purely geometric garb, Gregory did not perceive algebra and geometry as opposed fields. On the contrary, Gregory recommends the geometer to study the method of cartesian analysis, which offers an insight into the properties of figures themselves: "Huius methodi studiosus ante omnia versatus esse debet in analyse, nam absque illa, cuiusvis ingenii vires superat, propositae cujuscumque figurae proprietates examinare" (*GPU*, fol. IV: "The researcher of this method should be an expert in analysis above all, in fact without it, the examination of the properties of any figure surpasses the intellectual capacities of anyone"). In this context, Descartes' method for problem solving was not denied, but fused into a larger body of techniques, and the appeal to convergent sequences, derived from the geometrical properties of the figures examined, rather than from the algebraic equation expressing their properties, would be the "last recourse" (*ultimum nostrae methodi refugium*) when the quadrature of a figure failed to receive a solution via other purely geometric approaches: "Quod si geometra, post diligentem huius methodi applicationem secundum figurae proprietates, nullum inveniat problematis exitum; recurrendum est ad seriem convergentem, cuius terminatio sit ipsa figura incognita vel alia ad eam in ratione data. . ." (*GPU*, fol. V: "And if the geometer, after the proper application of this method according to the properties of the figure, cannot find any solution, he must resort to convergent series, whose limit is the unknown figure or another one, in a given ratio with this one"). See Malet [1989], p. 226).

¹⁴⁰*GPU*, p. 7: "If someone wishes to square the circle or divide an angle in a given ratio, organically, I can't see how it can be done in a manner simpler than by the vulgar quadratrix line, described in the solid and in the plane, accurately and pointwise". Gregory was probably referring to the generation of the quadratrix from the cutting of solid sections (described in Pappus' *Collection*, book IV, proposition 28, 29) or from a point by point construction (this can be found in Clavius, in book VI of his Commentary to Euclid's Elements, published in 1598).

¹⁴¹We can think, for instance, of the impossibility of solving the angle trisection by ruler and compass, or of the impossibility of solving the circle-squaring problem by algebraic curves as warranting the extension of geometry to higher curves, algebraic or mechanical, respectively.

This is another reason why Gregory may have adopted as a general and encompassing criterion for geometricity the simplest method, that is the simplest curves, that can solve a given problem. The question gets more entangled, though, when we consider simplicity as a criterion for extending the domain of geometric objects, and establish which curves ought to be added to the domain of the given ones.

Let us recall that, from the outset of his work, Descartes interpreted Pappus' norm prescribing to solve each problem according to its nature as a constraint on the choice of the algebraically simplest curves. Therefore, in order to make this requirement effective, a criterion for excluding too simple and too complex curves was required too. The constraint on the choice of the simplest solution - meaning, in this case, the algebraically simplest - constituted a strong normative stance orienting the practice of problem solving in cartesian geometry, with the consequence of imposing, for some cases, too counterintuitive or convoluted solutions. Descartes never adopted the ideal consisting in identifying geometry with the simplicity of solutions, but at most, he elected simplicity as a criterion for choosing among several geometrical solutions the most adequate for the problem at hand.¹⁴²

Interestingly, Gregory also made notable contributions to the field of analytic geometry, moved by the work of Van Schooten, Huygens and Sluse. His correspondence reveals that Gregory was both interested in the general problem of constructing equations and in the solution of geometrical problems by the simplest curves, both issues having their origin in Descartes' *Géométrie*.¹⁴³

Actually, Gregory's manuscripts on analytical geometry date from 1670-71 only, i. e. three years almost after the publication of *VCHQ*, but we cannot exclude that concern for simplicity in mathematical practice might have been transmitted to him through the knowledge and the reception of cartesian geometry. Several clues indicate that Gregory had a knowledge of cartesian geometry while writing *VCHQ*, although the depth of such knowledge cannot be exactly scrutinized.

¹⁴²On the other hand, reactions such as Newton's, Leibniz's or Fermat's ones prove that the cartesian ideal of simplicity (or algebraic simplicity) was not shared, in so far it lacked important epistemic virtues in the construction of problems, such as elegance, easiness and conciseness. See Bos [1984], p. 356ff.

¹⁴³Gregory's extant manuscripts on the theory of equations date from the last months of his life, from May to October 1675 (Gregory [1939], p. 382-389). This study resumes and tries to answer to a question referred in *VCHQ* as an open one: "nam ex his petenda est demonstratio (...) quod non semper et quando aequationes affectae possunt reduci ad puras..." (*VCHQ*, p. 5). On the other hand, his extant contributions to analytical geometry date from the year 1670, as the correspondence and manuscripts reveal (Gregory [1939], p. 435-439).

The recurrent theme of simplicity is a suggestive motive which permits to link Gregory's work to Descartes' geometry, to the point that Gregory's proposal to define a solution 'geometrical' on the ground of simplicity might have been inspired by a direct or indirect knowledge of Descartes' work. As I have already stressed, though, this was not Descartes' view, and interpreting geometry in this way would raise some counterintuitive consequences, as soon as we consider familiar examples.

Indeed, if simplicity, understood as algebraic simplicity, defined the boundaries of geometry and geometrical solutions, one must exclude as ungeometrical the well-known solution of the cube duplication by means of a curve traced with the compass of proportion, or 'mesolabum'. A second problem is related to the extension of our criteria of simplicity, when algebraic simplicity can no longer be employed, as in the case of the circle-squaring problem. How to judge about the simplicity of different solving methods, then? No clues are to be found in Gregory's works that may clarify such issues. At any rate, the connection between the theme of simplicity in Descartes' and in Gregory's approaches to geometry allows us to advance a further general conjecture: the influence cartesian geometry exerted over the development of mathematics during the second half of XVIth century must be measured also in the backdrop of broad methodological questions concerning the interplay between simplicity and impossibility results in geometry.

This conjecture is further confirmed by the role that the very impossibility result treated by Gregory will play in another important work from the second half of XVIIth century, namely the *Quadratura Arithmetica* written by G.W. Leibniz among 1674 and '76. This will be the theme of the next chapter.

7.6.1 Bibliographical note

As Turnbull remarks in the Memorial Volume (Gregory [1939], p. 25): "three sources of Gregory's works exist: his books, his letters and his notes". The edition of Gregory's work I have consulted are the following ones:

- *Vera circuli et hyperbolae quadratura, in sua propria specie inventa* (abbreviated as *VCHQ*), Patavii ex typographia Iacobi de Cadorinis, 1667 (Gregory [1667]).
- *Geometriae pars universalis* (abbreviated as GPU), Patavii Pauli Frambotti, 1668 (Gregory [1668b]).
- *Exercitationes Geometricae* (Abbreviated as EG. see Gregory [1668a]), Giulielmi Godbid, 1668. Later reprinted in N. Mercator, *Logarithmo-technia sive methodus*

construendi logarithmos nova, accurata, & facilis; scripto antehac communicata, anno sc. 1667 ... cui nunc accedit. Vera quadratura hyperbolae & inventio summae ..., Londini, 1668 (Mercator [1668]).

Concerning the corpus of letters and notes, I have fruitfully consulted H.W. Turnbull, *James Gregory Tercentenary Memorial Volume*, listed in bibliography as [Gregory, 1939], and the volume six of the complete works of C. Huygens, listed in the bibliography as Huygens [1888-1950].

Chapter 8

The arithmetical quadrature of the circle

8.1 Introduction

In this chapter, I shall discuss Leibniz's early inquiries on the circle-squaring problem, whose first grand result was the treatise: *De quadratura arithmetica circuli ellipseos et hyperbolae cujus corollarium est trigonometria sine tabulis* (hereinafter *De quadratura arithmetica*), composed and ultimated during Leibniz's stay in Paris (which extended from 1672 to September 1676),¹ but published only in 1993.²

My interest for the *De quadratura arithmetica* will be mainly directed towards the concluding proposition LI, the "crowning" of the treatise, as Leibniz called it.³ This proposition asserts that the problem of the indefinite, or "general", or again "universal" (in Leibniz's terminology) quadrature of the central conic sections cannot be solved by a

¹Leibniz arrived in Paris in Spring 1672, with little knowledge of mathematics and limited awareness of the developments this field underwent during the earlier 35-40 years. By his departure, in September 1676, he had gained insightful knowledge of most of the debated questions and advances at his time, as his manuscript production and his letters show us (Hofmann [2008], p. 12).

²Here and in the following sections, I will use the letter 'A', followed by a roman and an arabic numerals, in order to refer to the edition of Leibniz's collected works published by the *Akademie der Wissenschaften*. Thus, 'AVII6' will refer to the sixth volume of the seventh tome of the Edition of the *Akademie der Wissenschaften*, and 'AVII6, 51' will refer to the text number 51 contained in that volume. In particular, AVII6, 51 contains a new critical edition of the *De quadratura arithmetica*, with some additional passage with respect to the first edition made by E. Knobloch in 1993 (by simplicity, I will use the shorthand 'LKQ' in order to refer to Knobloch's edition). Finally I will use the abbreviation 'LSG' for Gerhardt's historical edition of Leibniz's mathematical works published in seven volumes (1849-1863).

³I am referring to proposition LI, see: AVII6, 51, p. 674; LKQ, p. 134.

better method, or expressed through a more geometrical relation than the ones exhibited in *De quadratura arithmetica*. As I will argue throughout this chapter, Leibniz's result can be thus summarized: the quadrature of an arbitrary sector of circle, the ellipse and the hyperbola cannot be expressed by a finite polynomial equation.

I shall also argue in this chapter that Leibniz's impossibility result, presented in the concluding proposition of the *De quadratura arithmetica*, was the outcome of Leibniz's engaging with the main points at stake in the controversy which opposed Gregory and Huygens on the impossibility of the analytical quadrature of the central conic sections. Let us recall that the quarrel between Gregory and Huygens had come to an end, upon the tacit agreement of both parts, in February 1669. However, as I have argued in the previous chapter, Gregory's belief that no analytical quadrature of the central conic sections was neither proved nor disproved, by then.

Although few or no exchanges occurred between Huygens and Gregory in the subsequent years, they plausibly continued to ponder over the issue of the quadrability of conic sections. Meanwhile, due to his closeness with Huygens during his stay in Paris, Leibniz became acquainted to this issue and to the quarrels raised around it. I surmise that the impossibility result which closes the *De Quadratura Arithmetica* can be viewed as Leibniz's late-ripe attempt to terminate the controversy once for all.

Leibniz's results were only partially successful though. As I shall discuss in the sequel, the problem of the analytic solvability of the quadrature of the circle had not received a definite answer by the end of Leibniz's stay in Paris.

In a preliminary way, I will survey both the complex editorial history of the *De quadratura arithmetica*, and I will examine the scribal evidence which attests Leibniz's critical study of Gregory's mathematical works, between 1672 and 1676.

8.1.1 The manuscript of the *De quadratura arithmetica*

The editorial work on Leibniz's *Nachlass*⁴ has disclosed that Leibniz possessed a manuscript of a treatise on the arithmetical quadrature of the central conics, ready for publication, in September 1676. It can be determined with precision, on the ground of Leibniz's vast epistolary exchanges, that Leibniz had firstly conceived the project to print his treatise in

⁴On the complex editorial history of *De Quadratura Arithmetica* one can consult Knobloch [1989], Probst [2006b], Probst [2008a] and the introduction to the recently published AVII6.

Paris by confiding a copy to his friend Soudry, who remained in that city,⁵ while Leibniz moved firstly to London, for a brief period, and then, from the end of 1676 onwards, settled down in Hannover.

The project of preparing the treatise on the arithmetical quadrature for print, which was continued and perhaps ultimated by Soudry in the next years, was hindered by the loss, around 1680, of Soudry's copy.⁶

Leibniz still possessed the original of his parisian manuscript (this manuscript was published in LKQ and, with some additional passages, in AVII6, 51), and he inquired, in the years subsequent to the loss of Soudry's copy, whether other publishers may be interested in this work.

However, Leibniz finally turned down the opportunities to publish his arithmetical quadrature in its full length. His ultimate motivations, as revealed for instance in a letter to Bernoulli, written in the late nineties, concerned the content of the treatise which, by then, was judged obsolete by Leibniz.⁷

Leibniz rather published, starting from 1682, few articles containing results and material drawn from his parisian manuscript. I mention, in particular, the *De Vera Proportione Circuli ad Quadratum in Numeris Rationalibus Expressa*,⁸ the *De geometria recondita et analysi indivisibilium atque infinitorum* (1686),⁹ and in particular the following three papers:

- a short tract: *Quadratura Arithmetica communis Sectionnum Conicarum quae centrum habent* (1691) published in the *Acta Eruditorum* (See LSG, V, p. 128);
- A *Praefatio opusculi de quadratura arithmetica*, written in 1676, (LSG, V, p. 93-98): this was an introductory piece to a treatise on the arithmetical quadrature of the circle, different than LKQ.
- And a *Compendium quadraturae arithmeticae* (LSG, V, p. 99), written in 1690-91.¹⁰

⁵Cf. AIII2, p. 104, 105, 116, 129, 145; AIII1, p. 482.

⁶The copy was lost in the post, in the route from Paris and Hannover. See Knobloch [1989], p. 132-133 for a detailed account.

⁷See LSG, 3, p. 522, 528, 537.

⁸Leibniz [1682]. Also in LSG, 5, p. 120. See also: Leibniz [1989], p. 77, for a French translation.

⁹Leibniz [1686], also in LSG, 5, pp. 226-233; Leibniz [1989], p. 126.

¹⁰Probst [2008a], p. 171.

According to Leibniz's testimony, the years 1675-76 are presumably the years in which he completed what he considered the final version of this treatise.¹¹ Before reaching a final version, Leibniz composed several drafts of the *De quadratura arithmetica*, starting from 1673, which circulated among his friends and fellow mathematicians (the first known mention of his arithmetical quadrature was made by Leibniz in a letter to Henry Oldenburg, the permanent secretary of the Royal Society, from 15.7.1674.¹²

From fall 1673 to October 1674 Leibniz also composed four Latin treatises (in chronological sequence: AVII4 42; AVII6 1, 3, 8 = AIII1 39.1) and a French treatise (AIII1, 39, sent to Huygens). From late in 1675 two French fragments are extant, destined for La Roque (AIII1, 72) and supposedly for Gallois (AIII1, 73).¹³ The successive manuscripts date from spring to September 1676: AVII6, 14 (fragmentary), 20 + 28, 51. Conclusively, we can say that Leibniz worked on the problem of the quadrature of the circle from 1673 (AVII4, 42) to September 1676, the last month of his stay in Paris.

It should be remarked that proposition LI, in which an impossibility result is enunciated, appears in the 1676 version of the treatise (AVII6, 51), probably ultimated in September 1676, and before it, the same proposition occurred only in the draft AVII, 6 n. 28 (a previous version of the *De quadratura arithmetica*, dating from Summer 1676). Statements analogous to proposition LI can be found in the already quoted *Praefatio* from late spring 1676 (AVII, 6 n. 19, p. 176-177), and, stated as a theorem, but not proved, in the tract AVII6, 18, also composed in spring 1676. The textual evidence suggests therefore that, by Spring 1676, Leibniz had definitely planned to insert an impossibility result in his treatise.

8.1.2 Leibniz's acquaintance and study of Gregory's works

Several manuscripts from Leibniz's vast *Nachlass*, recently published in volumes AVII 3, 5, 6 of Leibniz's mathematical works, have disclosed the details of Leibniz's critical reception both of Gregory's arguments about the impossibility of squaring the central conic sections,¹⁴ and of other notable contribution of Gregory to the foundations of

¹¹Cf. for example "Quadratura Arithmetica communis Sectionum Conicarum", in; LSG, 5, p. 128. In Parmentier's translation: "Dès 1675, j'avais composé un petit ouvrage de quadrature arithmétique..." (Leibniz [1989], p. 176).

¹²AIII1, 120. See Knobloch [1989], p. 128.

¹³Concerning the latter, I point out that, in his *Catalogue Critique* of Leibniz's manuscripts, Rivault mentions Huygens as a recipient.

¹⁴In particular: AVII3, 20, 60; AVII5, 47; AVII6, 18, 19, 28, 41, 49.

calculus and the study of series.

It must be reckoned that Leibniz was informed about Gregory's *Vera Circuli et Hyperbolae Quadratura* already in 1668 by a copy of a letter from Oldenburg to Curtius.¹⁵ cursory remarks, to be found in a letter sent to Jean Gallois in 1672 and in a manuscript from the end of 1672, reveal that Leibniz was aware of Gregory's *VCHQ* (I will keep also in this chapter this abbreviation for: *Vera Circuli et Hyperbolae Quadratura*) or at least knew the geometrical double sequence defined by Gregory in that work, from the beginning of his parisian sojourn.¹⁶

A group of texts published in AVII4 (resp. numbers 3₁, 3₂) offers plausible information concerning the way in which Leibniz came to know and read the *Exercitationes Geometricae*, the third booklet published by Gregory, which contains as well valuable considerations on the impossibility of the analytical quadrature of the circle. It can be determined with certainty that Leibniz acquired this book during his first visit to London, in Spring 1673.¹⁷ It is important to note that, during the same visit, he could buy and later peruse two other mathematical works, subsequently bound together in a unique volume, still kept in Leibniz's library in Hannover: a part from Gregory's *Exercitationes Geometricae*, also Mercator's *Logarithmotechnia sive methodus construendi logarithmos nova, accurata & facilis* (1668) and Michelangelo Ricci's *Geometrica Exercitatio de maximis et minimis* (1668).¹⁸

¹⁵The letter dates from 13. Juli 1668 (See AIII, N. 9 p. 17-18).

¹⁶See AIII, 1 p. 3: "... Archimedes iam olim usus est arithmetica infinitorum atque indivisibilium geometria et inscriptis et circumscriptis in Dimensione Circuli (...) Iac. Gregorius inscripta et circumscripta". Also: "Methodus universalis hactenus usitata est, ea quam primus attulit Archimedes, per circumscripta inscriptaque polygona, quam postea Ludolphus a Colonia, Willebrordus Snellius, Iac. Gregorius Scotus, aliique provexere" ("A universal method is so far very common, the one that Archimedes brought the first, by inscribed and circumscribed polygons, and that later Ludolph of Koln, Willebrod Snellius, James Gregory from Scotland and others improved").

¹⁷As Gerhardt recalls: "Leibniz paid two visits to London from Paris (...) was from January 11 to the beginning of March 1673; the second was made on his way home to Germany, when he stopped in London for about a week, in October, 1676" (in Child [1920], p. 159).

¹⁸See Hannover, *Niedersächs. Landesbibl.* Ms IV 377; AVII4, 3, p. 48; AVII5, 47, p. 332. In a letter to Huygens from 1692, Leibniz returned on Gregory's the *Exercitationes Geometricae*, observing: "J'ai vû autre fois les Exercitations de Jacobus Gregorius, et peut-estre que vous me les aviez monstrées vous même.", but this memories is arguably incorrect, since it appears that Leibniz bought his own copy of the book. I point out that it is also possible that Huygens showed some or all of Gregory's books to Leibniz already in 1672/3 before Leibniz went to London and bought the *Exercitationes*. There are early references to Gregory in AIII,1, 2 and in VII,1 3; but perhaps Leibniz refers to the articles in the *Philosophical Transactions* and the *Journal des Sçavans*.

Later on, I will have occasion to explain how the technique used by Leibniz in *De quadratura arithmetica* in order to derive his series for $\frac{\pi}{4}$ is particularly indebted to Mercator's *Logarithmotechnia*. For the moment, I shall complete my survey of Leibniz's acquisition of the other texts written by Gregory. It is indeed certain that, by the end of 1673, Huygens lent to Leibniz both a copy of his *De circuli magnitudine inventa* and a copy of Gregory's *Vera Circuli et Hyperbolae Quadratura*, as it is recorded in Huygens' notebooks: "1673. 30 dec. prestè a Libnitz mon livre de Circuli magn. et Gregorius de Vera Circuli quadratura".¹⁹

Finally, the *Geometriae Pars Universalis* was the last of Gregory's books perused by Leibniz, in 1675. As Hoffman notes, "Leibniz was immensely interested in this book", although it seems that he did not work through it, but studied only some propositions.²⁰ Leibniz's interest for this work is not directly related to impossibility results, but to the

¹⁹Huygens [1888-1950], vol. 20, p. 388. An early 1674 references to *VCQH* can be found in AVII6, 3. Leibniz critically mentioned Gregory, in relation to the *Vera circuli et hyperbolae quadratura*, also in two letters to Oldenburg from March 1675 (AIII,1, p. 202 and AIII,1 p. 207), and August 1676 (LBG:198). Gregory's achievements were discussed by Leibniz on other occasions too, which occurred however after 1676, and therefore after the temporal bounds of this study. For instance, Leibniz was outspoken in a letter to Tschirnhaus, from 1684 (AIII, 4, p. 174), and in the context of a controversy on Tschirnhaus' alleged method for the integrability of algebraic curves: "Id ipsum scilicet ego objeci, verum hujus precautionis nullum in ejus edito Schediasmate reperitur vestigium, sed quia probaverat non dari quadraturam circuli portionumque ejus indefinitam, quod dudum constabat, sine haesitatione concluderat impossibilitatem quadraturae totius circuli, in quo argumentandi modo et Jac. Gregorius insignis geometra olim lapsus erat, quaemadmodum recte a viro celeberrimo Christiano Hugenio fuit observatum". Other critical references to Gregorie can be found in a letter to Wallis, dated 28 May (or 7 June) 1697, where Leibniz remarked: "Ostendit mihi olim Hugenius Parisiis Jac. Gregorii perbreve libellum in 4 in quo videbatur aliqua contineri promotio serierum convergentium, sed ἀνγματιχῶς quamquam mihi inspicere tantum in transitu non legere vacarit" (AIII, 7, p. 428). Although Leibniz claims here that he only ran through Gregory's book, he probably read the first part, concerning Gregory's impossibility argument, as we can suppose especially in the light of the manuscripts now published as: AVII,6 n. 18, 28. Finally, there is a later manuscript (*Paralogismus Jac. Gregorii cum circuli algebraice quadrari posse negat*, LH 35, XIII, 1, Bl. 118. This piece is also mentioned in Breger [1986], p. 121) which refers to a "paralogism" committed by Gregory. As it can be read in the manuscript, the paralogism concerns Gregory's definition of convergent series, not his impossibility arguments. At any rate, its dating is still uncertain, although it was possibly written during Leibniz's stay in Hannover (it might be well related to the exchanges with Wallis from 1697). Probably around the same period must be dated Leibniz's annotations to Gregorie's copy of *Vera Circuli Hyperbolae Quadratura* (in particular proposition X, XXV), to be found in Hannover's Library (Marg. Ms 98).

²⁰The first mention of this book made by Leibniz occurs in a letter to Oldenburg, from March 1675 (AIII, 46, p. 202). In (Hofmann [2008], p. 75-76), Hofmann argues that Leibniz did not possess a personal copy while in Paris. This conclusion is justified on the basis of the extant collection of books possessed by Leibniz, now in the Library of Hannover. There are in fact two copies of the *Geometriae Pars Universalis*, one came to Leibniz after Huygens' death (I signal that this copy contains Huygens' annotations), occurred in 1695, and the other derived similarly from Martin Knorr's library (Hofmann [2008], p. 76, Mahnke [1925], p. 29). The copy of Knorre (catalogued as Marg. 98) contains also a reissue of the *VCHQ*, annotated by Leibniz. The annotations are obviously later than 1676, and may be dated to the end of XVIIIth century.

research on the quadrature of figures based on a method for transforming a given plane bounded region into an equivalent surface.²¹

Conclusively, important scribal evidence shows that Leibniz became conversant, during the years 1673-1676, with Gregory's attempts to prove the impossibility of squaring the central conic sections analytically, and criticized them by reenacting and deepening Huygens' objections. Moreover, there is room to argue, as I will explicate at length in this chapter, that the structure, the rationale and the content of Leibniz's proposition LI of the *De Quadratura Arithmetica*, which expounds Leibniz's result about the impossibility of squaring the circle analytically, were crucially shaped by his reading of the published pieces which composed the controversy between Gregory and Huygens.

8.2 The arithmetical quadrature of the circle, its main results

8.2.1 Looking backward onto Leibniz's quadrature of the central conic sections

As I said in the beginning of the chapter, the ultimate draft of the *De quadratura arithmetica* ended, according to the evidence in our possession, with the following theorem, considered by Leibniz: "the crowning of his contemplation":²²

Impossibile est meliorem invenire Quadraturam Circuli Ellipseos aut Hyperbolae generalem, sive relationem inter arcum et latera, numerumve et Logarithmum; quae magis geometrica sit, quam haec nostra est.²³

According to my reading, Leibniz introduces, in the above statement, two equivalent impossibility claims (this may be the sense conveyed by the disjunctive particle "sive"), via two comparatives. Firstly, Leibniz states that it is impossible to find a better general quadrature than his own, namely better than the solution he has found and presented in the very treatise concluded by proposition LI. Secondly, Leibniz excludes that one might express a more geometrical relation between arcs and subtending chords (*latera*)

²¹See, in particular, Hofmann [2008], p. 86-89.

²²"Coronis erit contemplationis hujus nostrae" (AVII 6, n. 28, p. 349; 51, p. 674).

²³AVII6, 51, p. 674: "It is impossible to find a better general quadrature of the circle, the ellipse or the hyperbola, or a relation between the arc and its chords, or between the number and its logarithm, which is more geometrical than our own".

or between logarithms and numbers than the ones he discovered and expounded in the *De Quadratura Arithmetica*.

In order to understand the significance of Leibniz's impossibility claim, I deem therefore important to delve into the content of the positive part of the *De quadratura arithmetica*, in which Leibniz offers a solution to the problem of squaring the central conic sections (the circle, the ellipse and the hyperbola).

A survey of the structure of *De quadratura arithmetica* shows that this treatise may be divided in three sections.²⁴ A first part (propositions 1-11) contains Leibniz's attempt to give a rigorous justification to the infinitesimal techniques on which his inquiry on quadratures was based.²⁵ A second part, which spans from proposition 12 to proposition 25, contains a set of preparatory theorems for the quadratures of the circle and the hyperbola, which are offered in the third part (proposition 26-51). Indeed, from proposition 27 to proposition 32, Leibniz presents the arithmetical quadrature of a sector of the circle, obtained by expressing the area of the sector by means of an infinite series, and deduces what can be called, nowadays, the alternate converging series for $\frac{\pi}{4}$, namely: $\frac{\pi}{4} = 1 - \frac{1}{3} + \frac{1}{5} - \dots + \frac{(-1)^n}{2n+1} + \dots$ ²⁶ Then, from proposition 42 to proposition 50, Leibniz deals with the arithmetical quadrature of the hyperbola. Finally, proposition 51, the 'crowning' of Leibniz's treatise, contains his result concerning the impossibility of a more geometrical quadrature of the central conic sections.

As it appears from this survey, Leibniz presented his impossibility result only after having explicated his own method for quadratures, and having exhibited a solution to the quadrature problems. Leibniz operated, therefore, a reversal with respect to the structure of the *VCHQ*. In this work, let us recall, Gregory set out to investigate whether an analytical (i.e. algebraical) method for squaring the central conic sections might be given, before entering the *pars construens* of his inquiry.

²⁴Knobloch [1989], p. 139.

²⁵As remarked in AVII6, p. XXIV, Leibniz occupied himself with this justification from 1675 onwards (see in particular AVII6, 14, dating from early 1676, AVII6, 20, from Spring 1676, and the latest version of the *De Quadratura Arithmetica* AVII51, propositions I-XI. The methodological aspect of Leibniz's research into the arithmetical quadrature was neglected until very recently, with perhaps the sole exception of the pioneering work of L. Scholz. Nowadays, it has been unravelled by several scholarly studies. I will refer in particular to the following essays: Knobloch [1999a], Knobloch [2002] and Knobloch [2008]. See also the recent: Arthur [2013].

²⁶See Child [1920], p. 163; Dutka [1982], p. 117, p. 121.

On the contrary, the order followed by Leibniz is perhaps indicative of the stages through which his research proceeded. Indeed, as the available manuscript evidence can show us today, Leibniz firstly discovered the arithmetical quadrature of a sector of the circle, probably already in 1673,²⁷ then he generalized his method to the hyperbola²⁸ and only in the last stance, he set out to give a foundation of his method and to establish its limits, by arguing the impossibility of attaining a ‘more geometrical’ result, for what concerns the quadrature of a central conic sector.

In what follows, I shall advance a reconstruction of the pattern which led Leibniz to the discovery of the arithmetical quadrature of a circular sector, and on this basis, to the deduction of his series for $\frac{\pi}{4}$. In order to accomplish this reconstruction I will directly rely on Leibniz’s drafts of *De quadratura arithmetica* from 1674 (namely: AIII1, 39, AVII6, 4) and 1675 (AIII1, 72, 73), and only indirectly on the *De quadratura arithmetica* itself. In fact, although most of the results obtained in 1674 and 1675 drafts were later conflated in the final version of the treatise, Leibniz privileged, in *De quadratura arithmetica*, a stricter deductive ordering and a synthetic presentation of his results, which are reformulated in the classical language of Euclid’s theory of proportions. This ‘synthetic style’, possibly chosen in view of a publication, has the disadvantage to conceal the original process of discovery and the possible influences exerted by other mathematicians on Leibniz’s quadrature techniques.

As a general, preliminary remark, let us point out that the technique on which Leibniz relied in order to solve the problem of squaring the central conic sections differs from the one employed by Gregory in the *VCHQ* on one fundamental aspect. Whereas the latter employed an ingenious variant of the Archimedean method of inscribed and circumscribed polygons, avoiding therefore infinitesimal considerations, in order to construe a convergent sequence to the sector,²⁹ the essential background of the method applied by Leibniz

²⁷For the datation of the first fragments, see: Probst [2006b] and Probst [2008a].

²⁸The drafts of the *De quadratura arithmetica* discussed, until 1676, only the case of the circle; subsequently, Leibniz decided to expand his treatise in order to countenance the case of the hyperbola too. This conclusion is supported by the analysis of the relevant drafts. Let us remark, in particular, that the quadrature of the hyperbola is indeed absent from the drafts of the *De quadratura arithmetica* until half 1676 (cf. *Quadraturae circuli Arithmeticae pars secunda*, AVII6, 28).

²⁹It should be pointed out, though, that the Archimedean process consisting in ‘squeezing’ a circle by two sequences of inscribed and circumscribed polygons was a technique relying on infinitesimals, in Leibniz’s opinion. Leibniz wrote, for instance, in his *Accessio ad Arithmetica Infinitorum* (end of 1672): "Archimedes jam olim usus est Arithmetica Infinitorum atque Indivisibilium Geometria, inscriptisque atque circumscriptis in Dimensione Circuli, in de Sphaera et Cylindro, in Quadratura Parabolae: et Geometriam quidem Indivisibilium resuscitavit nostro seculo Cavalerius obstetricante atque probante Galilaeo; Wallisius Arithmetica Infinitorum, Jac. Gregorius inscripta ac circumscripta; et vero nisi

in order to solve the quadrature of the circle was Cavalieri's method of indivisibles.³⁰

8.2.2 Towards the arithmetical quadrature of the circle: the transmutation theorem

Leibniz's path towards the arithmetical quadrature of the circle might be ideally divided in two parts, that we can call 'geometrical reduction' and 'analytical solution'.³¹ The

nova ex indivisibilibus et infinitis Lux affulgeat et ars analyseos provehatur, nulla spes est provehendae magnopere Geometriae", AIII, 109, p. 343.

³⁰Hofmann [2008], p. 51. During the second half of XVIIth century, it was indeed common indeed, as displayed by several examples and discussions in the works of Wallis, Mercator or Pascal, to conceive a surface not as the aggregate of all its ordinates without breadth (according to Cavalieri's ideas), but as being covered by infinitely many small parallelograms. At any rate, the 'correct' way to conceive the concepts of indivisible and infinitesimal was a debated issue at the time (*Cf.* Giusti [1980], Andersen [1986], Malet [1996], among others), and the same mathematician could entertain eclectic opinions on the issue. It is worth mentioning here the case of Wallis, for instance, who adopted a rather tolerant attitude, at least in his *De Sectionibus Conicis Nova Methodo Expositis, Tractatus* (1655) and in his *Arithmetica infinitorum* (1656), by admitting either the cavalierian interpretation consisting in considering the surface of a plane region as an aggregate of parallel lines, or the interpretation consisting in considering a surface as filled with infinitely many parallelograms with small base. Thus he wrote in his treatise on conic sections: "I suppose, from the beginning (after Bonaventura Cavalieri's Geometria Indivisibilium) that any [portion of] plane consists, as it were, of infinitely many parallel [straight] lines, or rather (as I would prefer) of infinitely many parallelograms equally high, the altitude of each of which is $\frac{1}{\infty}$ of the total altitude, that is, an infinitely small aliquot part (for ' ∞ ' denotes an infinite number), so that the altitude of all [such parts] taken together is equal to the altitude of the figure." (tr. Pasini [1993], p. 45-46). Few lines after, Wallis justifies his scarce interest in taking a side with respect to the question about the real nature of the indivisibles, on the ground that both interpretations evoked in the passage above are operationally equivalent (Wallis [1695, 1693, 1699], vol 2, pp 4-5). Also Pascal endorsed, in his *Lettres de A. Dettonville, contenant quelque une de ses inventions de géométrie*, an interpretation of indivisibles as rectangular strips of infinitesimal coarseness, that will influence in particular Leibniz's early views on the subject. Leibniz firstly started to employ the term 'indivisible' according to the pascalian definition and use, that he thus paraphrased and understood in a consideration from early 1673: "Note: in the same way as it is necessary in equations in geometry, when lines are compared with surfaces or surfaces with solids or lines with solids, that a unity is given (whence in numbers equations between dimensions of different degrees are freely admitted), so it is necessary in the geometry of indivisibles, when it is said that the sum of lines is equal to some surface or the sum of surfaces to some solid, that a unity be given, that some line is given, of course, as whose applicates they are understood, or that they are multiplied into one of the infinitely many equal parts of that line each of which denotes the unity, so that infinitely many surfaces are generated, though they are smaller than any given surface" (AVII4, 10, p. 135; english translation by Probst [2008b], p. 102). Hence Leibniz, on the ground of his reading of the *Lettres de Dettonville*, considered himself entitled to employ the expressions: "the sum of lines is equal to a surface" or "the sum of surfaces is equal to some solid", using the word 'sum' (instead of 'aggregate') without violating homogeneity. In fact he understood by 'line' a rectangle with infinitesimal base, whose role was analogous to that of the unity, which suitably multiplied by a given magnitude can re-establish homogeneity between non-homogeneous terms of an equation (*Cf.* also Pasini [1993], pp. 52-53; Mahnke [1925], p. 32; Probst [2008b], especially pp. 100-103).

³¹Such a division does not mirror the organization of the final draft of *De quadratura arithmetica*, but corresponds to a thematic partition present more evidently in the first known couple of manuscripts of this treatise, dating from Autumn 1673 (AVII4, 42₁, 42₂), where, Leibniz had distinguished a "reductio geometrica" - a geometrical reduction (AVII4, 42₁), and a "solutio analytica" (AVII4 42₂), and in the

first part consists in reducing the problem of squaring an arbitrary sector of a central conic, delimited by an arc of the given curve and the chord joining its extremities to the problem of squaring another curvilinear figure, named "figura resectorum" or "figura segmentorum" in the *De quadratura arithmetica*, whose surface is the double of the conic sector.³²

This reduction is effectuated through a purely geometric construction method, called by Leibniz: "transmutatio",³³ which does not hold merely for the conic sections, but for a larger class of curves, although Leibniz originally applied this transmutation to a circular segment,³⁴ i.e., according to Euclid's definition: "the figure contained by a straight line and the circumference of a circle" (*Elements*, df. 6, book III).

The transmutation theorem is a fundamental stage in Leibniz's pattern towards the solution of the circle-squaring problem, as he still acknowledged, almost forty years after its original formulation, in *Historia et Origo Calculi differentialis*.³⁵ Let us then consider the general case, and assume that a 'smooth convex'³⁶ curve η is given (fig. 8.2.1). With vertex in one of its points A , let a right angle BAT be traced as in fig. 8.2.1. The ray AB is called by Leibniz "axis", and AT is called "conjugate axis". Let us then consider a sequence of points C_i arbitrarily chosen on the curve, and draw, from each of these points,

excerpts sent to Huygens, La Roque and Gallois (AIII1, 39, 72, 73).

³²In Leibniz's corpus of manuscripts concerning quadrature problems, an explicit definition of *figura segmentorum* can be encountered, among others, in the following places: AVII6, 4, p. 53, AVII6, 8, p. 94, AVII6, 20, p. 202, AVII6, 51, p. 539. On the other hand, the analogous expression *Figura resectorum* occurs at AVII6 51, p. 535.

³³The term 'transmutatio' (see AVII4, 11, for one of the first uses of the term by Leibniz) was current in the geometrical practice of the second half of XVIIth century, and it was probably borrowed by Leibniz from Van Heuraet's *Epistola de transmutatione curvarum linearum in rectas*, where the word appears in the very title, or from Gregory's *Geometriae Pars Universalis* (Mahnke [1925], p. 10). Let us observe, however, that in Van Heuraet it denoted in particular the transformation of an arc into a straight lines, namely, a rectification. It is not the case in Leibniz, where the term denotes the construction of a curve from a given one.

³⁴On the ground of the extant manuscripts, we can establish that this theorem generalizes to sectors of arbitrary curves a result on the surface of circular segment delimited by an arc and its subtending chord, firstly discovered in 1673 (see AVII4, 42₁; AVII6, 1, p. 5). Generalizations of this theorem appear in the drafts of the *De Quadratura Arithmetica* from 1675 onwards. I refer, in particular, to the version sent to La Roque (see for instance AIII, 72, p. 341; 347), and to the subsequent AVII6, 14, p. 140, VII6, 51, proposition VII, p. 533-534.

³⁵See Child [1920], p. 41ff.

³⁶By this, I refer to a continuous curve, without inflection nor vertical points. The first condition (in other words, the curve should contain no gaps) is indispensable, since Leibniz explicitly requires to take neighboring points on the curve. The second and third conditions are imposed by the construction protocol in order to trace the companion curve, that I will summarize in the text, but they can be easily circumvented by suitably dividing the curve into portions (Knobloch [2002], p. 63).

lines parallel to AT , meeting AB in corresponding points B_i (segments B_iC_i are called by Leibniz "ordinates"). Hence, from each point C_i , let the tangents C_iT_i be produced so as to meet AT in corresponding points T_i . From each T_i , let the perpendicular to AT be dropped so as to meet the corresponding segments C_iB_i in a point D_i .

Leibniz claims that points D_i will form the locus of a new curve γ such that the area of an arbitrary segment $\widehat{AC_iA}$, delimited by an arc of η curve and by its subtending chord, is half of the corresponding *figura segmentorum*, namely the trapezoid AD_iB_iA delimited by the curve γ , by the ordinate B_iD_i and by the axis AB .³⁷

In order to prove that the ratio between the segment $\widehat{AC_iA}$ and the trapezoid AD_iB_iA is $\frac{1}{2}$, Leibniz applies one of the chief principles of the method of indivisibles: if two plane (or space) regions A and B are subdivided into indivisibles, or into an infinite number of small rectangles (or prisms), such that there is a one-to-one correspondence between each infinitesimal element of A and each elements of B , and that corresponding infinitesimals have equal areas (or volumes), then A and B have equal area (or volume).³⁸

Instead of dividing the segment $\widehat{AC_iA}$ into an infinite number of small rectangles, as it was current in early modern geometric practice, Leibniz chooses to divide the figure at hand into an infinite number of curvilinear triangles, having their common vertex in point A , and small arcs of the curve η for basis. In Leibniz's parlance, the basis of these triangles touching the curve would constitute the sides of an inscribed "infinitangular polygon".³⁹

The reason of such a triangular division will become clear in the light of what follows. In fact, let us consider two neighboring points C'_2 and C_2 on a given curve η (in fig. 8.2.2). Let AC'_2C_2 be the triangle with vertex in A and basis C'_2C_2 , and let $B'_2C'_2$ and B_2C_2 be the ordinates passing through C'_2 and C_2 . Let T_2 be the intersection point between AT

³⁷See, in particular, AVII6, 14, p. 140ff. AVII6, 51, pp. 533ff. I notice that whereas in AIII, 1, 72, (p. 342) the right angle BAT is required to have its vertex on the curve, this requirement falls in the subsequent versions of the *De Quadratura Arithmetica* (cf. for instance AVII6, 51, p. 533), so that the right angle can be placed anywhere in the plane. This modification in the text of the theorem does not change its content (as we might say, the relation between a segment and its *figura segmentorum* is invariant by rigid displacement of the referential frame), but it might show that Leibniz was moving towards a conception of an orthonormal referential frame, lying in the plane and fixed before drawing other figures in it.

³⁸Cf. Chisini [1912], p. 106.

³⁹Cf. AIII1, 72, p. 341.

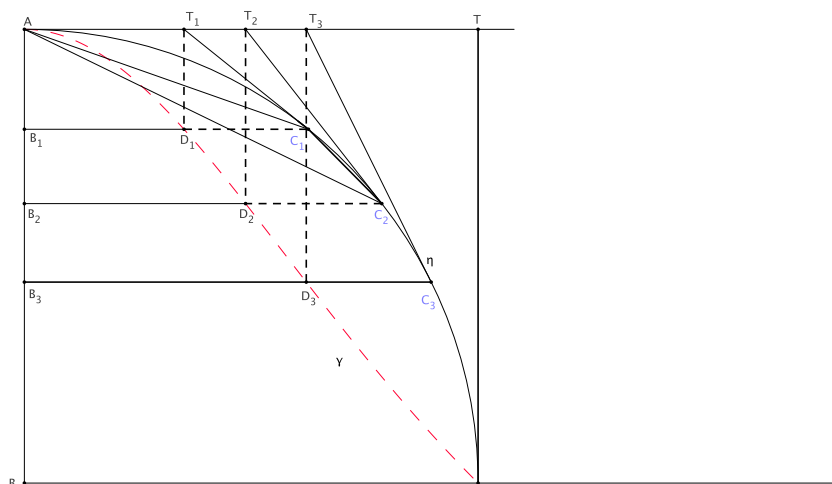

Figure 8.2.1: Construction of a *figura segmentorum*.

and the tangent C'_2C_2 to the curve η .⁴⁰ From T_2 , let the perpendicular to AT be traced, such that it meets $B'_2C'_2$ and B_2C_2 in points D'_2 and D_2 , respectively.

From this construction, it follows that the area of the triangle AC'_2C_2 is half the area of the rectangle with sides B_2D_2 and D'_2D_2 . In order to prove this relation, let a segment AO be drawn, perpendicular to line $C_2C'_2$ extended, and let the right angled triangle C'_2NC_2 be constructed, with C'_2C_2 as hypotenuse, and C'_2N , C_2N as legs (see fig. 8.2.2. Leibniz called this triangle "*triangulum characteristicum*"). In virtue of the similarity of triangles C'_2NC_2 and AOT_2 (both right-angled triangles), the following proportion holds:

$$C'_2N : AO = C'_2C_2 : AT_2.$$

⁴⁰Leibniz requires both points C'_2 and C_2 to lie on the curve, therefore the line passing from C'_2 and C_2 is strictly speaking, a cord lying on a secant to the curve. But since the distance between these two points is taken very small or, as Leibniz would say, "infinitesimal" (see for instance: AIII, 1, 72, p. 341), the cord C'_2C_2 becomes indistinguishable from the tangent to η in C_2 (or C'_2). Leibniz can therefore consider C'_2C_2 as a tangent to the curve, as we read in the draft of the *De Quadratura Arithmetica* sent to La Roque: "... or ces bases ou costez du polygone [namely the infinitangular polygon formed by the chords] prolongez sont les touchantes de la courbe" (AIII, 1, 72, p. 341).

length equal to the subtangents in C_i was:⁴¹

$$\frac{\sum_{i=1}^h T_i}{\sum_{i=1}^h R_i} = \frac{1}{2}. \quad (8.2.1)$$

Since the aggregate of all the triangular strips fills in the surface of the segment $\widehat{AC_iA}$, and the aggregate of all the rectangular strips fills in the surface of the trapezoid AD_iB_iA , namely the *figura segmentorum*, it follows that:

$$\frac{\widehat{AC_iA}}{AD_iB_iA} = \frac{1}{2}.$$

This is the core of the analytic solution to the arithmetical quadrature of the circle, which allows Leibniz to measure the surface of any segment of a circle indirectly, by measuring the area of the trapezoid obtained from it through a suitable application of the method of transmutation.

8.2.3 Towards the arithmetical quadrature of the circle: the generation of the ‘anonymous’ curve

Since the result sketched in the previous section holds for the case of the circle too, Leibniz could rely on it, in order to find the ratio between the area of a segment $\widehat{AC_2A}$ of a circle with center B and radius BA (fig. 8.2.3 below) and its corresponding *figura segmentorum* AD_2B_2A . In this way, the problem of squaring a circular segment was reduced to the squaring of another curvilinear figure.

Apparently, the problem of squaring the latter figure can be equally difficult as that of squaring the former, since the figure to be squared is still bounded by a curve, whose nature is, in principle, unknown. But Leibniz showed, as I will expound below, that that the area of the *figura segmentorum* obtained from a segment of the circle could be easily

⁴¹See Child [1920], p. 39, Mahnke [1925], p. 10-11; Hofmann [2008], p. 54-56. In the expression below, the symbol: ‘ $\sum_{i=1}^h T_i$ ’ indicates the operation of ‘filling’ a certain surface, as a circular segment, with infinitely many triangles (h must be taken as an infinite number) having as basis a an infinitely small part of the arc, or, in the terminology of the theory of indivisibles, it indicates the ‘aggregate of all cords’ filling the surface of the figure.

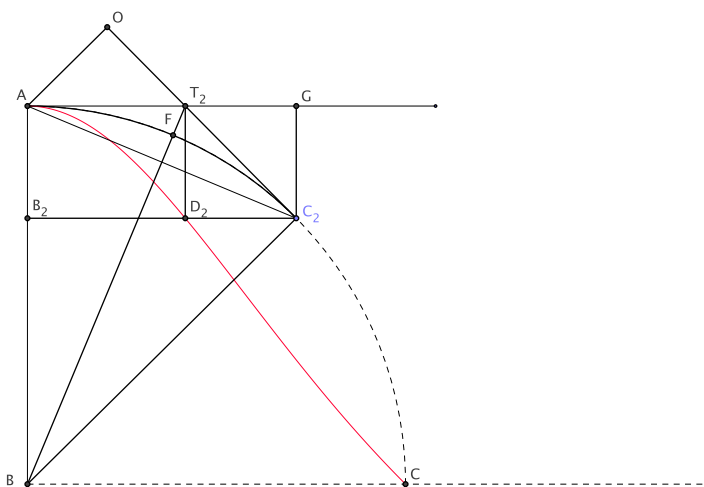

Figure 8.2.3: *Figura segmentorum* associated to the circle.

found by applying a procedure originally developed by Mercator in order to square the hyperbola.

Let us return, by now, to the problem of describing the *figura segmentorum* associated to a circular segment. The first step undertaken by Leibniz, as it clearly shines through the account presented in the drafts to Huygens, for instance, consists in characterizing the curve generated by transmutation from the circle (marked in fig. 8.2.3 below) via its algebraic equation.⁴²

Let us consider the arc of circle \widehat{AC}_2 , whose tangent in C_2 intercepts, in a point T_2 , the tangent in the other extremity A . Leibniz calls AT_2 "tangent of the arc \widehat{AF} ", with F midpoint of \widehat{AC}_2 . The other tangent segment C_2T_2 is then extended to the point O , foot of the perpendicular drawn from A . Obviously AO is parallel to the radius BC_2 .

⁴²See in particular the piece sent to Huygens (and its drafts) from 1674: AIII, 1, 39, p. 142ff.; AVII6, 8, p. 92ff. See also AVII6, 51, pp. 527-528.

Leibniz then goes on to define two other segments: AB_2 , the ‘*sinus versum*’ of the arc \widehat{AC}_2 , according to the current terminology borrowed from classical trigonometry, and segment B_2C_2 , the ‘*sinus rectum*’ of the same arc.⁴³

In virtue of the similitude between triangles BAT_2 and AB_2C_2 , the following proportion ensues: $AT_2 : AB = AB_2 : B_2C_2$. Since AT_2 and B_2C_2 are parallel, and so are AO and BC_2 (this is by construction), triangles AOT_2 and BB_2C_2 are similar, therefore a second proportion ensues: $AO : B_2C_2 = AT_2 : BC_2$. But it can be easily proved that $AO = AB_2$ (in fact triangles C_2GT_2 and AOT_2 are similar: the angles OT_2A and GT_2C_2 are equal because opposite, whereas angles OAT_2 and GC_2T_2 are both complementary of the equal angles OT_2A and $T_2C_2B_2$, and therefore are equal between them). Hence: $AB_2 : B_2C_2 = AT_2 : BC_2$, or $AB_2 : B_2C_2 = AT_2 : AB$.

Leibniz then proceeds according to the canon of cartesian analysis,⁴⁴ and names: $AB_2 = x$, $AB = BC_2 = a$, $AT_2 = y$. From the proportions derived above, he can infer $B_2C_2 = \sqrt{2ax - x^2}$ and, from $AT_2 : AB = AB_2 : B_2C_2$, the following:

$$y = \frac{ax}{\sqrt{2ax - x^2}}$$

In order to eliminate the irrational quantity figuring in the quotient, Leibniz rewrites the above expression so as to obtain: $y(\sqrt{2ax - x^2}) = ax$, then raises both members to the square and derives the following equation:

$$x = \frac{2ay^2}{a^2 + y^2} \tag{8.2.2}$$

Equation 8.2.2 expresses the relations between the distances (here understood not as lengths, but as segments joining the points orthogonally to a straight line) from any point D_i , constructed according to the protocol above, to the tangent AT (extended) and to the radius AB , respectively. Therefore this equation defines a curve, locus of all

⁴³It is easy to translate the ‘*sinus versum*’ and ‘*sinus rectum*’ in a modern terminology. Setting the radius $AB = 1$, we can assume: $\widehat{AC}_2 = \theta$ (θ expresses the measure of the arc \widehat{AC}_2 in radians), and: $AB_2 = 1 - \cos \theta$, $B_2C_2 = \sin \theta$.

⁴⁴He explicitly refers to cartesian calculus, for instance in III, 39, p. 154, 142.

points D_i . Since the equation is algebraic, the curve is geometrical, in cartesian sense, and can be constructed by continuous motion via a suitable geometric linkage.

Leibniz never constructed this curve by continuous motions, at least to my knowledge, although he often represented it, in his diagrams, as a continuously drawn curve, and studied its properties.⁴⁵ This curve was even left without a proper name in the *De Quadratura Arithmetica*, but, as revealed by early occurrences, was initially called "anonymous". We read, for instance, in the draft sent to Huygens in October 1674:

J'ose bien l'appeler Anonyme par excellence, car quoyqu'elle soit sans nom, elle est pourtant une des plus considérables après les Coniques, et beaucoup plus simple que la Cissoeide ou la Conchoeide, n'estant que de troisieme degrez, si les Coniques sont du deuxieszme, et outre cela estant du nombre de celles que j'appelle Rationelles.⁴⁶

The "anonymous curve" is indeed simpler than the conchoid or the cissoid, if we refer, as Leibniz certainly did, to the cartesian idea of the simplicity of a curve, measured by its degree. On the other hand, Leibniz calls the curve "rational": by this, he arguably means that its associated equation, when it is written in the form: $x = f(y)$ or $y = f(x)$, does not contain any irrational expression.⁴⁷

In the 1680s (see for instance LSG5, p. 123), Leibniz called this anonymous curve a "quadratrix" of the circle: this name that does not bear any relation to the quadratrix of the ancients, which was a transcendental curve instead. In Leibniz's later terminology, the word 'quadratrix' refers, in general, to a curve which enhances the quadrature of a figure bounded by another given curve, as it is the case of the quadratrix of the circle. This further stage will be explored in the next sections.

⁴⁵For instance, see AIII, 1, 39, p. 157.

⁴⁶AIII, 39, p. 156, p. 163, . In his reply (*Cf.* AIII, 40, p. 170) Huygens proposed to call thus curve "en luy donnant quelque nom composé des noms de deux lignes dont je trouvois qu'elle estoit produite, qui sont le Cercle et la Cissoide des anciens". Huygens' proposal is clear if we consider the analytical expression of the curve: in fact, each ordinate y can be expressed as: $y = \frac{x^2}{\sqrt{2ax-x^2}} + \sqrt{2ax-x^2} = \frac{ax}{\sqrt{2ax-x^2}}$. With Huygens, we can recognize, in the first term: $\frac{x^2}{\sqrt{2ax-x^2}}$, the expressions of the ordinates of a cyssoide in terms of its abscissae, and in the second one the expressions of the ordinates of the circle.

⁴⁷I interpret in this way Leibniz's definition: "Figuram rationalem voco cujus abscissae sunt rationales ad ordinatas vel ordinatae ad abscissas, id est quae aequatione exprimi possunt in qua unius incognitae valor purus simplexque est" (AIII, 39, p. 142: "I call rational figure, whose abscissae are rational to the ordinates, or the ordinates to the abscissas, i.e., which can be expressed through an equation, in which the value of one of the unknown is pure and simple"). See also AIII, 1 73, p. 359.

8.3 A digression: Mercator-Wallis technique for the quadrature of the hyperbola

The second step of Leibniz's quadrature of the circular segment $\widehat{AC_2A}$ consists in finding the area of the associated *figura segmentorum* by an analytical computation involving infinite series. Once obtained this result, the area of the circular segment can be derived in virtue of the simple proportion relating it to the *figura segmentorum*.

As the exam of the extant manuscripts tells us, Leibniz's process for squaring the *figura segmentorum* essentially depended on the method employed by Mercator in order to solve the quadrature of an hyperbolic sector, in his treatise: *Logarithmotechnia: sive methodus construendi logarithmos nova, accurata, et facilis* ("Logarithmotechnia: or new, accurate, and easy method of constructing logarithms", 1668), and on the account of this book given by Wallis, in two letters from July and August 1668 appeared in the *Philosophical Transactions* (cf. Wallis [1668b]).⁴⁸ In this section, I will go through Mercator's and Wallis' quadrature of the hyperbola, and explain in the next section how Leibniz could apply their methods to the case of the circle too.

Mercator's quadrature of the hyperbola represents one of the principal results of the *Logarithmotechnia*, a treatise dedicated to the properties of logarithms. The connection between logarithms and the surfaces of hyperbolic sectors, namely, the spaces bounded by the hyperbola and individuated by a segment on the abscissa and by the normals to the hyperbola taken from the endpoints of the segment, was made clear during XVIIth century, especially thanks to the works of Gregoire of St. Vincent and Sarasa.⁴⁹

It must be recalled that the term 'logarithm' does not characterize the same notion for us and for early modern geometers. In the context of early modern geometry, instead, logarithms were understood as: "numbers with constant differences matched with numbers in continued proportion".⁵⁰ In other words, logarithms appeared primarily in order to study and evaluate numerically the correspondence between arithmetical and geometrical progressions. Let us consider, for instance, a geometric sequence: $a_1, a_2, a_3,$

⁴⁸Indeed both works have been studied by the young Leibniz. Leibniz's reading of the *Logarithmotechnia* can be dated, from his marginal notes, to 1673 (see VII3, 6, 8). On the other hand, Leibniz quoted Wallis' account already by the end of 1672 (See for instance: AVII3, 6, p. 107). Leibniz recalled the importance of Mercator also in the later work *Historia et Origo* (Child [1920], p. 45).

⁴⁹For a reconstruction of Gregoire's and Sarasa's contribution to the history of logarithms, see Burn [2001].

⁵⁰Burn [2001], p. 4. Burns is citing here Briggs' definition in *Arithmetica logarithmica* (1624).

... and an arithmetical sequence: b_1, b_2, b_3, \dots . The terms of the second sequence were called 'logarithms', while the terms of the first sequence were called: 'numbers', provided: $b_k + b_l = b_m$ whenever $a_k \cdot a_l = a_m$.⁵¹ In a slightly anachronistic terminology, a one-to-one functional correspondence between the two sequences can be described by the functional equation:

$$f(a_k \cdot a_l) = f(a_m) = f(a_k) + f(a_l).$$

As proved by Gregoire of St Vincent and De Sarasa,⁵² given an equilateral hyperbola with asymptotes AE and AN (fig. 8.3) and taken on AN a succession of segments Ir, IK, IL, IO forming a geometric progression, the sectors $Biru, urKP, PKLQ, QLOR$ are equal. This property made the equilateral hyperbola an appealing graphical model of logarithmic relations. In fact, according to the definitions given above, the terms a_k in arithmetical progression (with respect to the hyperbolic model, such terms will be: $Biru, BIKP, BILQ, BIMR$) will be called: 'logarithms' while the terms A_k (with respect to the hyperbolic model, these terms will be: Ir, IK, IL, IO, \dots) are their 'numbers'.

Consequently, a method that allows the geometer to square the hyperbola, for instance by expressing its area as the (numerical) sum of small inscribed rectangles (as it will be done by Mercator), will therefore turn out useful for the numerical computation of the logarithms of given numbers. For this reason, Mercator dedicated the third part of his treatise (propositions XIV-XIX) to the problem of finding the quadrature of an hyperbolic sector.

Mercator's achievement is mentioned in several occasions by Leibniz in the *De quadratura arithmetica* (AVII6, 51, p. 566, 596-597, 616, 641-642), and in two introductory drafts to the treatise (VII6. 41, p. 438, 49, p. 510). This couple of drafts, in particular, cast light on the intellectual influence exerted by Mercator's achievement on Leibniz. For instance, in the middle of a long digression on the history of quadratures, Leibniz praises Mercator's method with these words:

⁵¹See Knobloch [1988], p. 297, and Whiteside [1961], p. 215. The computational advantage introduced by logarithms consisted in replacing the operation of multiplication with that of addition. This was, as Whiteside notes: "A cherished ideal when there were no automatic computing techniques at more than the most elementary level" (Whiteside [1961], p. 216).

⁵²See Burn [2001], for a detailed account.

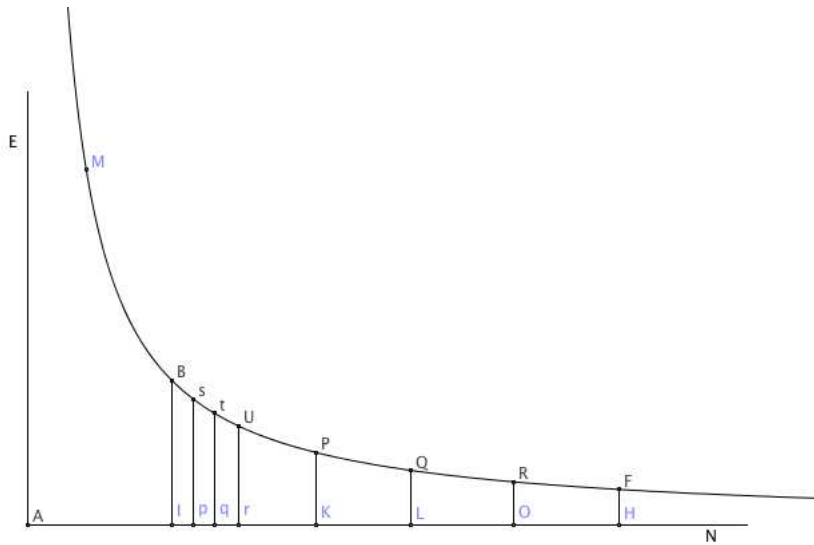

Figure 8.3.1: Hyperbola: logarithmic relation.

Mercator diversa plane ac pereleganti ratione rem longius produxit: consideravit enim numerum fractum exprimi posse serie integrorum infinita, (a) ut $\frac{1}{1+x}$ esse aequale quantitati: $1 - \frac{x}{1+x}$ et $\frac{x}{1+x}$ aequari huic $x - \frac{x^2}{1+x^2}$ et $\frac{x^2}{1+x}$ huic $x^2 - \frac{x^2}{1+x}$ et ita porro, ac proinde omnibus collectis aequari $\frac{1}{1+x}$ seriei $1 - x + x^2 - x^3$ etc. (aa) Jam per arithmetica infinitorum summa omnium 1 est x novissima; et summa omnium x est $\frac{x^2}{2}$ novissima (bb) Sit jam curva cuius abscissa sit x , ordinata $\frac{1}{1+x}$, qualis est Hyperbola erg. | vel $1 - x + x^2 - x^3$ etc. erit summa omnium ordinarum praecedentium seu area figurae, $\frac{x}{1} - \frac{x^2}{2} + \frac{x^3}{3} - \frac{x^4}{4}$ etc ut notum est ex quadraturis parabolaram.⁵³

We can recognize here the well-known expansion of the fraction $\frac{1}{1+x}$ (where $x < 1$ is opportunely assumed, in order to guarantee the convergence of the series) into the infinite

⁵³AVII6, 41, p. 438: "Mercator greatly improved the issue [namely, the problem of quadratures] in an utterly peculiar and very elegant way: he considered that a fractional number can be expressed by an infinite series of integers, such that $\frac{1}{1+x}$ is equal to the quantity: $1 - \frac{x}{1+x}$, and $\frac{x}{1+x}$ is equal to $x - \frac{x^2}{1+x^2}$, and $\frac{x^2}{1+x}$ to $x^2 - \frac{x^2}{1+x}$ and so on, and therefore once all the terms have been collected $\frac{1}{1+x}$ is equal to the series: $1 - x + x^2 - x^3 \dots$ Indeed, in virtue of the arithmetic of the infinites, the sum of all ones is the last abscissa (*novissima*) x ; and the sum of all x is the last abscissa (*novissima*) $\frac{x^2}{2}$. Let indeed a curve, like the hyperbola, whose abscissa is x , and ordinate $\frac{1}{1+x}$, or $1 - x + x^2 - x^3$ etc. the sum of all the previous ordinates or the area of the figure will be $\frac{x}{1} - \frac{x^2}{2} + \frac{x^3}{3} - \frac{x^4}{4}$ etc, as it is known from the quadratures of the parabolaram".

series $1 - x + x^2 - x^3 \dots$, which is effectively done in Mercator's *Logarithmotechnia* (see Mercator [1668], prop. XV, p. 30) and represents a crucial step in order to square an hyperbolic sector (Mercator [1668], prop. XVI, p 31). As we read in the passage above, in order to divide 1 by $1 + x$, Leibniz simply set: $1 - \frac{x}{1+x} = 1 - R$, and found R (in this case, $R = \frac{x}{1+x}$), then set: $R = x + S$, and found S , and so on. Continuing this division *in infinitum*, he obtained the same result obtained by Mercator, namely the power series: $\frac{1}{1+x} = 1 - x + x^2 - x^3 \dots$.⁵⁴

This result is central for Mercator's quadrature method. In order to give an idea of the procedure which led to the quadrature of an hyperbolic sector, I will offer a reconstruction of the technique exposed in propositions XIV-XIX of the *Logarithmotechnia*, on one hand,⁵⁵ and of the interpretation given by Wallis in his account of the book appeared in the *Philosophical Transactions*, on the other.

Mercator's procedure starts from the consideration of an hyperbola FBM (fig. 8.3), such that its *latus rectum* is equals to its *latus transversum*, and with asymptotes AE and AN forming a right angle in A . By setting $AI = BI = 1$, and $IH = a$, Mercator deduces, in a purely geometrical way, that: $FH = \frac{1}{1+a}$.⁵⁶

Mercator then develops the fraction $\frac{1}{1+a}$ according to the method seen above, so as to obtain the equality: $\frac{1}{1+a} = 1 - a + a^2 - a^3 + a^4 \dots$.⁵⁷ Since 1 denotes a segment (Mercator posits: $AI = BI = 1$), also the expressions: " a ", " a^2 " (and so on) figuring in the right-hand member of the previous equality ought to be, by homogeneity, segments. Therefore Mercator can write the following equality down: $FH = 1 - a + a^2 - a^3 + a^4 \dots$.⁵⁸

⁵⁴The same process is resumed, with respect to the case of an arbitrary fraction $\frac{a}{b+c}$, in *De quadratura arithmetica* (AVII6, 51, p. 596).

⁵⁵Mercator's quadrature of the hyperbola has been discussed in Coolidge [1950], in Edwards [1994], p. 162-165 and in Ferraro [2008], p. 19-20.

⁵⁶Mercator [1668], p. 28-29; Wallis [1668b], p. 753. Mercator proves the proportion: $AH : AI = BI : FH$. This proportion holds in virtue of the well-known equivalence of all rectangles having one vertex coincident with the center of the hyperbola, while the opposite vertex lies on the hyperbola, and both sides lie on the asymptotes. Although neither Mercator nor Wallis refer to the hyperbola by means of its equation, it can be evinced from their accounts that the hyperbola has equation $y = \frac{1}{x}$ referred to its asymptotes.

⁵⁷Mercator [1668], prop. XVI, p. 30.

⁵⁸Let us recall that the expansion is valid if $a < 1$, therefore if $IH < AI$ for the case at hand. Mercator omits to state this condition explicitly. However the condition of convergence is explicitly remarked by Wallis (Wallis [1668b], p. 754). I also note that this part of the *Logarithmotechnia* was carefully read by Leibniz, as revealed by his marginal notes, (AVII4, 3, p. 49-50).

In order to square the hyperbolic sector $BIru$, Mercator proceeds by subdividing the sector Ir into numerous thin strips, whose basis are formed by equal segments of length α .⁵⁹ In order to illustrate his procedure, Mercator supposes Ir subdivided in three parts of equal length: $Ip = pq = qr = \alpha$. The sector will be equal to the sum of the three trapezoids: $BIs p$, $spqt$, $tqrU$ ("areolas").⁶⁰ and can be then approximated by the corresponding rectangles $r(Ip, ps)$, $r(pq, qt)$ and $r(qr, ru)$. Since $AI = 1$, we will have: $Ap = 1 + \alpha$. Let ps be the segment parallel to the asymptote AE , with s on the hyperbola: in virtue of the properties of the hyperbola, it will be: $ps = \frac{1}{1+\alpha}$. Accordingly, the rectangle $r(Ip, ps)$ will have its area equal to: $S_1 = \alpha \cdot \frac{1}{1+\alpha}$. If we consider a second thin rectangle $r(pq, qt)$, with t lying on the hyperbola, then its area will be: $S_2 = \alpha \cdot \frac{1}{1+2\alpha}$, and proceeding in a likewise manner, the third rectangle $r(qr, ru)$ will have area equal to: $S_3 = \alpha \cdot \frac{1}{1+3\alpha}$.

Since the hyperbolic sector from I to r is composed by the trapezoids $BIs p$, $spqt$, $tqrU$, its approximate surface may be computed by calculating the sum of the corresponding rectangular strips: $S(BIru) \simeq S_1 + S_2 + S_3 = \alpha(\frac{1}{1+\alpha} + \frac{1}{1+2\alpha} + \frac{1}{1+3\alpha})$. Mercator then employs to the expansion obtained before, in order to develop the terms $\frac{1}{1+\alpha}$, $\frac{1}{1+2\alpha}$, $\frac{1}{1+3\alpha}$

⁵⁹Mercator [1668], proposition XVII, p. 31. The expression employed by Mercator is "aequales partes innumeras", that may be translated as: "equal, innumerable parts". It seems to me that, on the ground of Mercator's way of proceeding, one should understand by this expression that the segment Ir is potentially divisible into infinitely many parts. Mercator, in his examples, divides it into finitely many parts, and finds an approximate quadrature of the hyperbola. Since the number of parts in which the segment can be divided can always be increased, the approximate measure can be improved better and better.

⁶⁰Mercator called α : "pars infinitissima" (Mercator [1668], p. 31), probably a deformation of "pars infinitesima". As Probst notes: "Leibniz seems to have coined the term 'infinitesimal' in late spring 1673 and he uses it most more frequently in the summer of that year (...). However there is an interesting difference in this respect between Mercator and Leibniz: the former does not use the term 'infinitesimal', but instead 'pars infinitissima' and he does so both for numbers and for lines (...). Mercator's expression signifies a minimal quantity and is therefore terminologically still close to Cavalieri's indivisibles, although he in fact employs infinitesimal quantities. By switching to the term 'infinitesima', which effectively paraphrases Wallis' symbolic expression $\frac{1}{\infty}$, Leibniz restores agreement between terminology and usage" (Probst [2008b], p. 103). This conclusion should be revised, though, in the light of the fact that Mercator himself changed his terminology in the immediately subsequent years, and adopted the expression 'pars infinitesima'. For instance, we read in his article: "Some illustrations of the Logarithmotechnia", appeared in the *Philosophical Transactions* n° 38 (1668), pp. 759-764, the following note: "atque ubicunque, Lector offenderit infinitissimam, legat infinitesimam". This was a reaction to the critique by Wallis at the beginning of his review of the book, printed in the same issue of the *Philosophical Transactions*, and already cited above (cf. Wallis [1668b]). We can therefore conclude that Mercator himself opted for the word 'infinitesima', and Leibniz arguably took this term from Mercator's article published in the *Philosophical Transactions*.

into power series:

$$\left\{ \begin{array}{l} \frac{1}{1+\alpha} = 1 - \alpha + \alpha^2 - \alpha^3 + \alpha^4 \dots \\ \frac{1}{1+2\alpha} = 1 - 2\alpha + 4\alpha^2 - 8\alpha^3 + 16\alpha^4 \dots \\ \frac{1}{1+3\alpha} = 1 - 3\alpha + 9\alpha^2 - 27\alpha^3 + 81\alpha^4 \dots \end{array} \right.$$

Subsequently he adds together the terms in the same power, so as to obtain, for the rectangular strips filling $BIRu$: $S_1 + S_2 + S_3 = \alpha(\frac{1}{1+\alpha} + \frac{1}{1+2\alpha} + \frac{1}{1+3\alpha}) = \alpha(3 - 6\alpha + 14\alpha^2 - 36\alpha^3 + 98\alpha^4 \dots)$. This result allows Mercator to compute the area of the sector by approximating it by means of the formula: $A(BIRu) \simeq \alpha(3 - 6\alpha + 14\alpha^2 - 36\alpha^3 + 98\alpha^4 \dots)$.

Provided the numerical measure of α ($\alpha = \frac{Ir}{3}$ in the case at point) is known, the area of the sector can be approximated numerically. This procedure yields better approximations of the sector, the more the number of divisions of Ir increases, and the smaller the parts α are correspondingly taken. By this result Mercator achieves "the squaring of the hyperbola" ("*quadrare hyperbolam*", prop. XVII, Mercator [1668], p. 31-32).

It is immediate for us to conclude, for n tending to infinity:⁶¹

$$A(BIRu) = n\alpha - \alpha^2 \sum_{i=1}^{i=n} i + \alpha^3 \sum_{i=1}^{i=n} i^2 - \dots + \alpha^{k+1} \sum_{i=1}^{i=n} i^k + \dots$$

However this conclusion is not explicit in Mercator's text. This step will be explicated, on the other hand, in Wallis' account of the book, appeared in July 1668 in the *Philosophical Transactions*. Wallis alerts the reader that he has introduced few terminological changes ("*pauca quaedam, Phraseologiam quod spectat, seu loquendi formulas nonnullas*", Wallis [1668b], p. 753) with respect to the *Logarithmotechnia*. However, these changes do not invest the sole terminology employed by Mercator, as I will unravel in the following.

Wallis refers to the same figure in Mercator's treatise, namely an hyperbola FBM , such that its *latus rectum* equals its *latus transversum*, with asymptotes AE and AN forming a right angle in A , and sets $AI = BI = 1$ and with $FH = \frac{1}{1+IH}$ (fig. 8.3). In order to

⁶¹I adopt, hereinafter, a modern notation merely for the purpose of conciseness, when it does not (so it seems to me) disturb the meaning of the original. The symbols " \sum ", with their relative indices and apices are to be encountered nowhere in XVIIth century mathematical text.

solve the problem of squaring the hyperbolic sector $BIru$, Wallis proposes to divide the segment between points I and r in "*aequales partes innumeras*". By this expression, we understand the segment as divided into an actual infinity of equal parts: " $\alpha, 2\alpha, 3\alpha \dots$ *usque ad A*", where ' A ', in this case, represents the length of Ir .⁶² In order to avoid confusions with point A (namely the center of the hyperbola in Mercator's and Wallis' configuration) I will indicate, from now on, the length of Ir with the less ambiguous letter ' X '.

Wallis states, borrowing the terminology of the method of indivisibles, that the ordinates corresponding to the subdivision of segment Ir "fill in" (*complementes*) the hyperbolic space.⁶³

Hence, the area of the hyperbolic sector $BIru$ might be thought of as the aggregate of the segments $ps, qt, \dots ru$, each segment being equal to: $\frac{1}{1+\alpha}, \frac{1}{1+2\alpha}, \frac{1}{1+3\alpha}, \dots, \frac{1}{1+h\alpha}$ (where h is an infinite number) from I to r (such that $Ir = X$). We might also think that segments $ps, qt, \dots ru$ are rectangular strips with heights equal to $\frac{1}{1+\alpha}, \frac{1}{1+2\alpha}, \frac{1}{1+3\alpha}, \dots, \frac{1}{1+h\alpha}$ and base equal to the small segment α , namely:⁶⁴

$$\mathcal{A}(BIru) = \sum_{i=1}^{i=h} \alpha \left(\frac{1}{1+i\alpha} \right)$$

The second step in Wallis' method consists in expanding each fraction: $\frac{1}{1+i\alpha}$ ($i = 1, 2, 3, \dots h$), by means of Mercator's procedure, so as to obtain:

$$\mathcal{A}(BIru) = \alpha \left[\sum_{k=0}^{\infty} (-1)^k \alpha^k \right] + \alpha \left[\sum_{k=0}^{\infty} (-1)^k (2\alpha)^k \right] + \dots + \alpha \left[\sum_{k=0}^{\infty} (-1)^k (h\alpha)^k \right].$$

⁶²Wallis is aware that $Ir < 1$ in order to ensure the convergence of the sum-series, otherwise: "if one queries the quadrature of a sector $BIHF$ (whose side IH is to be understood longer than AI) this procedure will not be successful: because the remedy, as we have said, will not be sufficient to cure the disease. Since, in fact, we must posit: $A > 1$; it is evident that its successive powers will become greater, hence they should not be neglected". Wallis could circumvent this problem, as he described in his Wallis [1668b], by changing the unity and setting: $AH = 1$.

⁶³Wallis [1668b], p. 753.

⁶⁴*Cf.* Edwards [1994], p. 162-163.

Collecting the terms containing equal powers of α , we obtain the following infinite sum for the area of $Biru$:

$$\alpha \sum_{i=1}^{i=h} (i\alpha)^0 - \alpha \sum_{i=1}^{i=h} (i\alpha)^1 + \alpha \sum_{i=1}^{i=h} (i\alpha)^2 + \dots (-1)^k \alpha \sum_{i=1}^{i=h} (i\alpha)^k + \dots \quad (8.3.1)$$

Without further detail, Wallis immediately writes the results of the sums $\sum_{i=1}^{i=h} (i\alpha)^k$ as:

$$\begin{aligned} \sum_{i=1}^{i=h} (i\alpha)^0 &= X \\ \sum_{i=1}^{i=h} (i\alpha)^1 &= \frac{X^2}{2} \\ \sum_{i=1}^{i=h} (i\alpha)^2 &= \frac{X^3}{3} \\ \sum_{i=1}^{i=h} (i\alpha)^3 &= \frac{X^4}{4} \\ &\vdots \end{aligned}$$

And states that the area of the hyperbolic sector $Biru$ is:

$$\mathcal{A}(Biru) = X - \frac{X^2}{2} + \frac{X^3}{3} - \frac{X^4}{4} \dots \quad (8.3.2)$$

given $Ir = X$.⁶⁵

Wallis' underlying reasoning might be reconstructed in the following way.⁶⁶ The formula 8.3.1 can be rewritten as:

$$\mathcal{A}(Biru) = \alpha \sum_{i=1}^{i=h} i^0 - \alpha^2 \sum_{i=1}^{i=h} i^1 + \alpha^3 \sum_{i=1}^{i=h} i^2 + \dots (-1)^k \alpha^{k+1} \sum_{i=1}^{i=h} i^k \dots$$

From which it follows, by setting $\alpha = \frac{X}{h}$ (since $Ir = X$):

$$\mathcal{A}(Biru) = \frac{X}{h} h - \frac{X^2}{h^2} \left(\sum_{i=1}^{i=h} i^1 \right) + \frac{X^3}{h^3} \left(\sum_{i=1}^{i=h} i^2 \right) + \dots (-1)^k \frac{X^{k+1}}{h^{k+1}} \left(\sum_{i=1}^{i=h} i^k \right) \dots$$

⁶⁵Wallis [1668b], p. 754.

⁶⁶I follow here the proposal advanced in Edwards [1994], p. 162ff., to which I am here particularly indebted.

In the *Arithmetica infinitorum*, Wallis had proved, by inductive enumeration from the cases of $k = 2, 3, 4, 5$, and for h equal to an infinite number, that the ratio between the two divergent series $\sum_{i=0}^h i^k$ and $\sum_{i=0}^h h^k$ is:⁶⁷

$$\frac{\sum_{i=0}^h i^k}{\sum_{i=0}^h h^k} = \frac{\sum_{i=0}^h i^k}{h^k(h+1)} = \frac{1}{k+1}.$$

From this, one can derive:

$$\frac{\sum_{i=1}^h i^k}{\sum_{i=1}^h h^k} = \frac{\sum_{i=1}^h i^k}{h^{k+1}} = \frac{1}{k+1}$$

Hence, Wallis plausibly relied on these results, obtained in the *Arithmetica Infinitorum*, in order to conclude:

$$\mathcal{A}(BIru) = X - \frac{X^2}{2} + \frac{X^3}{3} - \dots (-1)^k \frac{X^{k+1}}{k+1} \dots$$

which is nothing but the formula 8.3.2.

According to Whiteside (Whiteside [1961], p. 228), Mercator's power expansion published in the *Logarithmotechnia* inspired Wallis to achieve an 'exact' quadrature of the hyperbolic sector. I substantially endorse this judgement, and stress its historical significance: without compunctions, and perhaps for the first time in a published work, Wallis claims that the area of $BIru$ is equal to the sum-series: $X - \frac{X^2}{2} + \frac{X^3}{3} - \frac{X^4}{4} + \dots$.

Wallis does not delve at all, however, into the nature of the expression: " $X - \frac{X^2}{2} + \frac{X^3}{3} - \frac{X^4}{4} + \dots$ ". On the contrary, he stresses on two occasions the continuity between

⁶⁷Wallis [2004], p. 13-15 and proposition 64 (quoted in Wallis [1668b], p. 758). Cf. Panza [2005], p. 55-56.

Mercator's quadrature and the quadrature of paraboloids found in the *Arithmetica Infinitorum*.⁶⁸ Yet it seems that a fundamental shift in Wallis' mathematical practice has occurred between the *Arithmetica Infinitorum* (1655) and his reading of Mercator (1668), underscored by a change occurred in the very understanding of the solution to a quadrature problem.

In his 1655 work, in fact, Wallis still adhered to the classical idea according to which squaring a curvilinear figure S meant to find a proportion between the figure to be squared, another constructible figure (in general a circumscribed parallelogram or a rectangle) and two other quantities (for instance numbers), so as to derive a rule in order to construct a rectilinear figure equal to S .⁶⁹ On the other hand, it seems that, in 1668, squaring a figure like the trapezoid $Biru$ did not consist, either for Mercator or Wallis, in finding the ratio between the figure to be squared and a second rectilinear figure. In the 1668 account written by Wallis, for example, the quadrature of the sector of an hyperbola is solved by expressing the area of the figure by a series (the 8.3.2 above), namely an algebraic expression whose meaning however is not further explained by Wallis.

Yet an interpretation of the geometric significance series can be ventured, in the light of our previous discussions (See, in particular, chapter 6). Since the expression ' X ' denotes a segment (this was called, in XVIIIth century mathematical practice, "*ultima abscissa*"), it is arguable that also ' $\frac{X^2}{2}$ ', ' $\frac{X^3}{3}$ ', and so on ought, by homogeneity, denote segments. Therefore, their sum-series will denote a segment too. This leads to the following conjecture: in 1668, Wallis might have endorsed the practice, already in force in Van Heuraet's rectification from 1659 (examined in this study, see: ch. 6, sec. 6.3) to employ segments in order to measure magnitudes that are different than segments. On the ground of this hypothesis, the symbols ' X ', ' $\frac{X^2}{2}$ ', ' $\frac{X^3}{3}$ ', ... appearing in the expression of the area of $Biru$, should be understood as denoting segments measuring two-dimensional surfaces. Wallis does not specify which surface is measured, in particular, by ' X ', ' $\frac{X^2}{2}$ ', and so on.

However, a conjecture may be ventured. Let us start by remarking that, on the ground of well-known formulas for computing the areas of a rectangle and a triangle, ' X ' can denote a segment measuring the surface of a rectangle of base X and height equal to 1, whereas ' $\frac{X^2}{2}$ ' measures, in the domain of segments, the surface of a triangle with base

⁶⁸Wallis [1668b], p. 755.

⁶⁹Panza [2005], especially p. 58-60.

X and height X . Once clarified the unproblematic meaning of the first terms: X and $\frac{X^2}{2}$, Wallis could have assumed, on the ground of known results obtained through the method of indivisibles, that the expression ' $\frac{X^3}{3}$ ', denoted, in the domain of segment, the surface of a parabolic sector cut off by the segment Ir under the parabola of equation $y = x^2$, drawn or imagined to be drawn with I as a vertex. On the same ground, he might have taken ' $\frac{X^4}{4}$ ', to denote the surface of a trapezoid cut off by Ir under a cubic parabola of equation $y = x^3$ (traced with its origin in I). A likewise interpretation can be extended to the other terms appearing in the sum-series: $X - \frac{X^2}{2} + \frac{X^3}{3} - \frac{X^4}{4} + \dots$, by associating to each term a corresponding sector delimited by a paraboloid (namely a curve with cartesian equation: $y = x^n$, with n natural number).

As I have discussed in this study (cf. 6, sec. 6.3) it is obvious and natural to postulate that the sum of two or more surfaces measured by segments a and b is measured, in the domain of segments, by the sum-segment $a + b$. On this ground, we can conclude that the sum-segment: $X - \frac{X^2}{2} + \frac{X^3}{3} - \frac{X^4}{4} + \dots$ measures the surface $BIRu$ in the domain of segments, by measuring, in the same domain, the sum of the trapezoids determined by the family of curves with equation: $y = x^m$.

Wallis closes his account by stressing that the quadrature so obtained is so "complete and fast" ("*absoluta est tamque expedita*") that he did not know whether one should expect a better one.⁷⁰ This avowal closely reminds of Leibniz's statement about the impossibility to find better and more geometrical quadratures of the conic sections offered in *De quadratura arithmetica*. Indeed, this similiary may not be adventitious. Indeed Leibniz knew this passage well, since he recalled, in one of his manuscript notes, that: "insignis Geometra, Joh. Wallisius (...) pronuntiaverit (...) eam esse tam absolutam tamque expeditam Hyperbolae quadraturam, ut nescire se profiteatur an melior sperari debeat".⁷¹ Moreover, an attentive examination of the sources will reveal the deep influence of both Mercator's quadrature and, particularly, Wallis' review over the techniques which led to Leibniz's arithmetical quadrature of the circle.

⁷⁰Wallis [1668b], p.756.

⁷¹AVII6, 1, p. 30: "The celebrated geometer, J. Wallis claimed that it was such an absolute and fast quadrature of the hyperbola, that he confessed he did not know whether a better one should be expected".

8.4 Leibniz's arithmetical quadrature of 1674-'75

8.4.1 Extending Wallis-Mercator technique

Is there a way to extend Mercator's and Wallis' procedures for the quadrature of an hyperbolic sector to the quadrature of a circular segment? An answer was far from easy, as Leibniz conceded, since the general applicability of Mercator's technique encountered a major objection:

Caeterum nemo est qui non videat facilem hujus artificii ad Hyperbolam fuisse applicationem (...) At vero Circulum ipsum ita tractari posse, nemo opinor vel sperare ausus est. Ego cum ad commodam Circuli dimensionem illud maxime obstare viderem, quod ordinatae ex curva ejus ad axem alium quemcunque demissae valore per relationem ad abscissas expresso nunquam absolvi possent ab irrationalitate, cum contra in parabola et Hyperbola omnibusque paraboloeidibus et Hyperboloeidibus simplicibus possint. . . ⁷²

Similar remarks are frequent in Leibniz's considerations between 1673 and 1676,⁷³ pointing at an apparently unsurpassable problem: the technique devised by Mercator for the quadrature of the hyperbola could not be immediately applied to the quadrature of any algebraic curve, but only to those having rational ordinates corresponding to rational abscissas, like the hyperbola, the parabola or the higher parabolas (namely those curves with equation: $y = x^m$, with m integer), for instance, whose analytical expression could be developed according to the method of long division, and therefore solved on the basis of the protocol applied by Mercator to the hyperbola.⁷⁴ On the contrary, the circle represents one of the most blatant cases to which Mercator's algorithm of the long divisions failed to be immediately applicable, because an irrational expression emerges as soon as we want to rewrite the equation as $y = f(x)$, or, as we might say in a slightly

⁷²AVII6, 1, p. 31: "However, everyone see that the application of this artifice to the hyperbola was easy (...) But, in fact no one, I think, dared even hope that the circle could be treated this way. This would seem to me to impede the most an easy quadrature of the Circle: the fact that the ordinates, directed from the curve to any of its other axis, will never be free from irrationalities, provided their measure is expressed in relation to the abscissas. On the contrary, they can in the Parabola, and in the hyperbola, and in all the simple paraboloids and hyperboloids".

⁷³AVII4, 36, p. 596, AVII6, 41, p. 438, AVII6, 49₁, p. 510, AVII6, 51, p. 567, 641; AIII1, 39₂, p. 168.

⁷⁴In the *De Quadratura Arithmetica*, Leibniz invented for such curves the special name of "analytically simple". See, for instance, AVII6, 1, p. 31, n. 41, p. 438, and in particular AVII6, 51, p. 561: "*Curvam Analyticam simplicem* voco, in qua relatio inter ordinatas et portiones ex axe aliquo abscissas, aequatione duorum tantum terminorum explicari potest; sive in qua ordinatae earumve potentiae, sunt in multiplicata, aut submultiplicata directa, aut reciproca ratione; abscissarum, potentiarumve ab ipsis, vel contra" (the emphasis is in the original).

anachronistic terminology, to express the ordinates of a circle in terms of their respective abscissas.

By the end of 1673, Leibniz found out the means to circumvent the problem.⁷⁵ His solution, later expounded in *De quadratura arithmetica*, consisted in reducing the problem of squaring a circular segment delimited by an arc and the subtending chord to the quadrature of an associated "*figura segmentorum*", delimited by an algebraic curve of equation: $x = \frac{2ay^2}{a^2+y^2}$ (where a denotes the radius).

Leibniz's procedure, at least in the first drafts of the *De Quadratura Arithmetica*, closely follows Wallis' account of the *Logarithmotechnia*. Indeed, Leibniz started by setting: $\frac{x}{2} = \frac{ay^2}{a^2+y^2}$, and proceeded by setting $a = 1$ and by multiplying the numerator and the denominator by the same quantity, namely: ' $1 - y^2$ ', so as to obtain: $\frac{y^2}{1+y^2} = \frac{y^2}{1+y^2} \cdot \frac{1-y^2}{1-y^2}$. From this expression, he derived:

$$\frac{y^2}{1+y^2} = \frac{y^2 - y^4}{1 - y^4} = \frac{y^2}{1 - y^4} - \frac{y^4}{1 - y^4}$$

Then Leibniz expanded both the term $\frac{y^2}{1-y^4}$ and $\frac{y^4}{1-y^4}$ by employing Mercator's method of long divisions, and obtained:

$$\frac{y^2}{1 - y^4} = y^2 + y^6 + y^{10} \dots$$

$$\frac{y^4}{1 - y^4} = y^4 + y^8 + y^{12} \dots$$

⁷⁵AVIII, 27, p. 493. See also Mahnke [1925], p. 41.

Finally, he combined the above series so as to obtain the following power-series:⁷⁶

$$\frac{y^2}{1+y^2} = y^2 - y^4 + y^6 \dots \quad (8.4.1)$$

By means of this expansion,⁷⁷ Leibniz could then find the quadrature of half the trapezoid $\frac{AT_2D_2A}{2}$ (fig. 8.4.1), which, I note, is not the *figura segmentorum*, but the half of its complement.

⁷⁶Cf. AVII4, 42₂, p. 79; AIII1, 39, p. 160-161; AIII, 1, 72, p. 353; AVII6, 4, p. 58; AVII6, 51, p. 596ff. The condition of convergence (which, for the above fraction, corresponds to: $y^2 < 1$), is stated, as far as I could ascertain, in AIII, 39, p. 164; and *sparsim*, in the various drafts of *De Quadratura Arithmetica*, so that Leibniz was certainly aware of it. On this concern, I observe that in *De quadratura arithmetica* Leibniz offered a general exemplification of the method of long divisions by applying it to the arbitrary quantity: $\frac{a}{b+c}$. He started by the equality: $\frac{a}{b+c} = \frac{a}{b} - \frac{ac}{b^2+bc}$. Then, by replacing ac , b^2 , bc by a_1 , b_1 and c_1 , he got: $\frac{a_1}{b_1+c_1} = \frac{a_1}{b_1} - \frac{a_1c_1}{b_1^2+b_1c_1}$, and therefore: $\frac{a}{b+c} = \frac{a}{b} - \frac{ac}{b^2} + \frac{a_1c_1}{b_1^2+b_1c_1}$. Leibniz thus proceeded in a similar way, so as obtain: $\frac{a}{b+c} = \frac{a}{b} - \frac{ac}{b^2} + \frac{ac^2}{b^3} - \frac{a_2c_2}{b_2^2+b_2c_2}$, and stated (without proof) that the remainders of each division would continually decreased. Therefore, he concluded that, by iterating the same procedure, the ratio $a : (b+c)$ could be expanded into an infinite series: $\frac{a}{b} - \frac{ac}{b^2} + \frac{ac^2}{b^3} \dots$ (see Ferraro [2008], p. 37). It is important to remark, with Ferraro [2008], that Leibniz's approach presents peculiar differences with respect to the modern technique for the expansion of the function $f(c) = \frac{a}{b+c}$. In contemporary practice, given a function one can distinguish from the start constants, dependent and independent variables. If we consider the real function $f(c) = \frac{a}{b+c}$, we know by looking at its symbolic representation that c is an independent variable, while a and b are constant, and that $f(c)$ can be expanded into $\frac{a}{b} - \frac{ac}{b^2} + \frac{ac^2}{b^3} \dots$ under the condition of convergence that $|c| < b$. If we exchange b with c we will obtain a different function: $f(b) = \frac{a}{c+b}$, which can be developed under different conditions, namely only if $|b| < c$, and which gives rise to a different expansion. Leibniz, on the other hand, could associate *a priori* two possible expansions to the quantity denoted by the expression $\frac{a}{b+c}$. The first expansion occurs under the hypothesis that $c < b$, the second under the hypothesis that $b < c$ (quantities a , b , c were always supposed positive). The choice between the two was made *a posteriori*, once the algebraic expression was interpreted geometrically: in the case treated in the *De Quadratura Arithmetica*, for instance, the geometric configuration of the problem determines the condition of convergence, namely: $c < b$. According to Ferraro (Ferraro [2008], p. 37) this aspect of Leibniz's practice can be understood once we consider that Leibniz's fundamental insights, in the *De Quadratura Arithmetica*, were essentially of a geometrical nature: "Leibniz's analysis was not based upon the notion of function in the modern sense, but upon curves (...) given a figure F, Leibniz had some geometric quantities connected to the figure F and, according to specific circumstances, chose what were to be considered as variables and what were to be considered as constants" (*ibid.*). Thus, even when Leibniz derived the infinite expansion for the fraction: $\frac{y^2}{1+y^2}$, by applying what we may judge as purely formal or combinatorial rules, the result of the operation was still contingent on the conditions determined by the geometric configuration of the problem to be solved.

⁷⁷One of the first occurrences of this expansion, in which Mercator's name is also mentioned, is the already quoted AVII4, 27, p. 493. Leibniz explicitly refers to Mercator's method in a draft of the *De quadratura arithmetica* from 1675 (AIII1, 72, p. 344), for instance ("Il s'ensuit par la belle methode de Nic. Mercator..."); then also in AVII6, 4, p. 58, and on several occasions in the other preparatory drafts for the *De Quadratura Arithmetica*, as we have also seen above. Finally, Mercator's expansion is discussed in the *De quadratura arithmetica* too (AVII6, 51, p. 596). See also Mahnke [1925], p. 12, Hofmann [2008], p. 60.

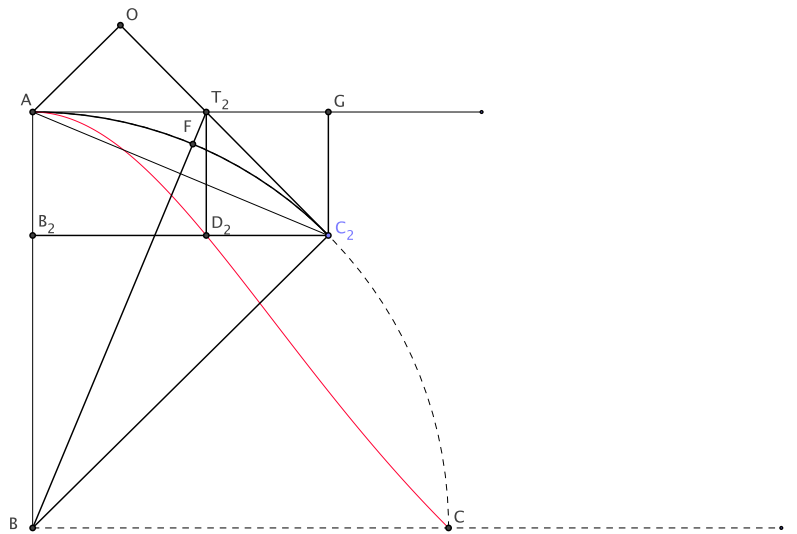

Figure 8.4.1: Leibniz's *figura segmentorum* relative to the circle.

The filiation of the method of quadrature here illustrated from Mercator's and Wallis' techniques is further confirmed by the letters Leibniz sent to Huygens and to La Roque.⁷⁸ In both accounts, Leibniz divides the segment AT_2 (namely the tangent of \widehat{AF} , in his parlance) into an infinite number of equal parts, each of infinitesimal length β ,⁷⁹ and finds the area of the trapezoid AT_2D_2A in the same way it is effectuated in Wallis' *Account* with respect to the sector of the hyperbola.⁸⁰

In brief, after having set the tangent $AT_2 = b$, Leibniz could compute the area of AT_2D_2A following Mercator-Wallis technique, and on the ground of the expansion obtained in 8.4.1, he obtained: ⁸¹

$$\mathcal{A}(AT_2D_2A) = 2\left(\frac{b^3}{3} - \frac{b^5}{5} + \frac{b^7}{7} \dots\right) \tag{8.4.2}$$

Once obtained the expression of the area of $\frac{AT_2D_2A}{2}$ in terms of the tangent b , the area of the segment $\widehat{AC_2}A$, delimited by the arc $\widehat{AC_2}$ and by its subtending chord AC_2 (fig. 8.4.1), as well as the area of the circular sector ABC_2A , delimited by the same arc $\widehat{AC_2}$ and by radii BA and BC_2 (fig. 8.4.1) can be easily inferred.

Leibniz could rely on the transmutation theorem in order to derive the expression of the surface of the segment $\widehat{AC_2}A$ (let us recall that $\widehat{AC_2}A$ is half of the curvilinear figure AD_2B_2A , in virtue of the 8.2.1 above). Then, posited: $R(AT_2, AB_2)$ as the area of the rectangle delimited by the segments $AT_2 = b$ and $AB_2 = x$, the area of the circular segment $\widehat{AC_2}A$ can be derived in what follows:

$$\mathcal{A}(\widehat{AC_2}A) = \frac{1}{2}(\mathcal{A}(R(AT_2, B_2A)) - \mathcal{A}(AT_2D_2A)) = \frac{xb}{2} - \left(\frac{b^3}{3} - \frac{b^5}{5} + \frac{b^7}{7} \dots\right) \tag{8.4.3}$$

⁷⁸I am referring to the letters published, respectively, as: AIII1, 39, and AIII1, 72.

⁷⁹Leibniz defines β as "infinitesimal part of the radius" (AIII1, 72, p. 344). In AVII6, 1, p. 16, he explicitly refers to Wallis' notation, by indicating the small β as: $\frac{1}{inf.}$ (assuming $AT_2 = 1$).

⁸⁰Cf. AIII,1 72, p. 344, where Wallis' procedure explained in the above section is followed almost step by step; and AVII6, 1, p. 24.

⁸¹I note that Leibniz's procedure in order to obtain this result is equivalent, from our viewpoint, to the term-wise integration of the integral: $\int_0^b \frac{y^2}{1+y^2} dy$ (provided $AT_2 = b$), obtained by developing the fraction $\frac{y^2}{1+y^2}$ according to the power expansion illustrated in 8.4.1.

On the ground of 8.4.3, Leibniz then computes elementarily the area of the sector ABC_2A included between the arc \widehat{AC}_2 and the radii $AB, BC_2 = 1$, obtaining:⁸²

$$\mathcal{A}(ABC_2A) = b - \frac{b^3}{3} + \frac{b^5}{5} - \frac{b^7}{7} \dots \quad (8.4.4)$$

8.4.2 The rectification of a circular arc

From the quadrature of an arbitrary sector of the circle, Leibniz could derive the rectification of the corresponding arc, by means of "ordinary geometry", as he pointed out.⁸³ If the radius of the given circle has been set equal to 1, we can obtain from 8.4.4 the length of the arc \widehat{AC}_2 (that we can symbolize as: $s[\widehat{AC}_2]$) in terms of an infinite series:⁸⁴

$$s[\widehat{AC}_2] = 2\left(b - \frac{b^3}{3} + \frac{b^5}{5} - \frac{b^7}{7} \dots\right) \quad (8.4.5)$$

This result is also expounded in proposition XXXI of the *De quadratura arithmetica*. In the *Scholium* to this proposition, Leibniz adds the following commentary:

Itaque si quis veram relationem analyticam generalem quaerit quae inter arcum et tangentem intercedit, is quidem in hac propositione habet, quicquid

⁸²AIII, 1, 39, p. 163-164. From fig. 8.4.1, $ABC_2A = ABC_2 + \widehat{AC}_2A$, where ABC_2 is the triangle with side AB and height B_2C_2 . By setting: $BA = 1$, $AB_2 = x$, $AT_2 = b = \frac{x}{\sqrt{2x-x^2}}$, $B_2C_2 = \sqrt{2x-x^2}$, and the area of ABC_2 will be equal to: $\mathcal{A}(ABC_2) = \frac{\sqrt{2x-x^2}}{2}$. On the ground of this result, and of the result of 8.4.3, one can derive the area of the sector ABC_2A as: $\mathcal{A}(ABC_2A) = \frac{\sqrt{2x-x^2}}{2} + \frac{xb}{2} - \left(\frac{b^3}{3} - \frac{b^5}{5} + \frac{b^7}{7} \dots\right)$. Let us then consider, with Leibniz, the sum: $\frac{\sqrt{2x-x^2}}{2} + \frac{xb}{2}$ (AIII1, 39, p. 164). Since $AT_2 = b = \frac{x}{\sqrt{2x-x^2}}$, we will have: $\frac{\sqrt{2x-x^2}}{2} + \frac{x}{2} \left(\frac{x}{\sqrt{2x-x^2}}\right) = \frac{\sqrt{2x-x^2}}{2} + \frac{x^2}{2\sqrt{2x-x^2}} = \frac{x}{\sqrt{2x-x^2}}$. But it has been posited that: $\frac{x}{\sqrt{2x-x^2}} = b$, hence: $\frac{\sqrt{2x-x^2}}{2} + \frac{xb}{2} = b$. Leibniz then concludes: $\mathcal{A}(ABC_2A) = b - \frac{b^3}{3} + \frac{b^5}{5} - \frac{b^7}{7} \dots$ (see 8.4.4 in the main next). As I will argue below, Leibniz's manipulation of the analytic symbols in order to compute surfaces can be explained in the light of a current (but probably tacit) interpretation of cartesian algebra of segments.

⁸³AIII1, 72, p. 350, AVII6, 51, p. 599. In the *Metrica*, Hero quotes the following theorem as a corollary of Archimedes' first proposition of the *Dimensio circuli*: every sector is half of the rectangle bounded by the periphery of the sector and the radius. The same theorem is evoked in Pappus' Commentary on Ptolemy's Book VI of the *Almagest* (cf. Knorr [1989], p. 377, p. 384). Obviously a formula in order to express the relation between an arc and its tangent cannot be derived, in the same elementary way, for an arc of hyperbola or ellipse.

⁸⁴See AVII4, 42, p. 752; AIII1, 72, p. 345; see also AVII6, 51, proposition XXXI.

ab homine fieri potest ut infra demonstrabo. Habet enim aequationem simplicissimi generis quae incognitae quantitatis magnitudinem exprimit cum hactenus apud geometras appropinquationes tantum, non vero aequationes pro arcu circuli demonstratae extent (...) Quare nunc primum hujus aequationis ope arcus circulares, et anguli instar linearum rectarum analytico calculo tractari possunt.⁸⁵

Two thesis can be singled out from the above passage, which illustrate the meaning of Leibniz's result about the rectification of a circular arc. Firstly, Leibniz states that a circular arc and its tangent are related by an equation (in formula 8.4.5 above) "... which expresses the magnitude of the unknown (*incognitae quantitatis magnitudinem exprimit*)", and therefore enables to treat quadrature and rectification problems by means of an "analytical calculus". Secondly, Leibniz claims that his result is the most exact that humans can attain, and adds that he has a proof for this claim: Presumably, Leibniz refers here to the impossibility argument presented in proposition LI, that I will analyze below.

Concerning the first claim, I point out that the leibnizian terminology reveals striking similarities with the cartesian one, in *La Géométrie*.⁸⁶ As seen in chapter 3, an equation of the form: $F(x, y) = 0$ has, in the context of cartesian geometry, an immediate geometric meaning, since it can be conceived as a shorthand for a proportion or a system of proportions. The possibility of coding proportions makes an equation in two unknowns as a suitable symbolic notation in order to represents a curve, in a classical way, by specifying its properties or symptoma. In particular, in the latin edition of *La Géométrie*, the one studied by Leibniz, we can read:

puncta omnia illarum, quae Geometricae appellari possunt, hoc est, quae sub mensuram aliquam certam et exactam cadunt, necessario ad puncta omnia lineae rectae, certam quandam relationem habent, quae per aequationem aliquam, omnia puncta respicientem, exprimi possit.⁸⁷

⁸⁵AVII6, 51, p. 600: "Hence, if one asks for a true analytical and general relation which intervenes between the arc and the tangent, he can find in this proposition everything that can be done by man, as I will prove below. He can find an equation of very simple kind, which expresses the magnitude of the unknown while geometers have only offered approximations so far, not equations which can express an arc of the circle. Therefore now we can for the first time treat, by means of such equation, circular arcs and angles as straight lines, by means of an analytical calculus".

⁸⁶The similarities between leibnizian and cartesian style are also discussed in Knobloch [2006], especially p. 120.

⁸⁷Descartes [1659-1661], p. 21.

The term "*relatio*" that occurs in the passage above is also employed by Leibniz, when he speaks of a "true analytical and general relation (*relatio*) which intervenes between the arc and the tangent".

In Leibniz's understanding, however, this relation is not an equation coding a proportion or a system of proportions, but the expression of a correspondence between an unknown segment, measuring a sector of the circle, or the arc bounding it, and another segment, namely the tangent of the arc (or its half). Hence the infinite sum: $b - \frac{b^3}{3} + \frac{b^5}{5} - \frac{b^7}{7} \dots$, in which each term is represented by the variable segment $\frac{b^n}{n}$, can be taken to measure, in the domain of segments, the surface of an arbitrary circular sector or the length of its corresponding arc.

I maintain that by referring to formulas like the ones expressed in equations 8.4.4 and 8.4.5 by the terms: "*relatio*" or "*aequatio*", Leibniz was still relying on the tradition of Descartes' geometry. Let us observe, in fact, that as far as an equation in two unknowns could be employed to denote a curve, it could be also interpreted as establishing a relation between the unknowns x and y , understood as variables quantities, and conceived as coordinates expressing the distances of a succession of point on the curve from two given lines. Descartes precisely exploited this possibility when he described the pointwise construction of curves solution to the Pappus problem in n lines (See ch. 3, and ch. 4).

In his Freudenthal [1977], Freudenthal distinguishes three possible meanings we can associate to the word "equation": that of "formal identity", that of "conditional equality involving unknowns to be made known", and finally that of "conditional equality involving variables".⁸⁸ We can say, on the ground of the analysis deployed in the previous chapters, that the three meanings coexist both in Descartes' geometry and in Leibniz's *De quadratura arithmetica*. But when the latter wrote that his solution to the problems of squaring a sector of the circle consisted in the discovery of "an equation (...) which expresses the quantity of the unknown" he was no more thinking of equations as encoding proportions between segments or, at least, he had de-emphasized this aspect, that was certainly prominent in cartesian geometry.

8.4.3 Leibniz's fictionalist stance

In praising the importance of his discoveries about the quadrature of the circle, Leibniz notes that for the first time he has managed to: "treat (...) circular arcs and angles as

⁸⁸Freudenthal [1977], p. 194.

straight lines by means of an analytical calculus" (AVII6, 51, p. 600). This achievement, on which he would often insist, since it marked in his view the overcoming of Descartes' restriction to problems concerning segments alone, is grounded on a redefinition of the concept of curve in terms of an infinitangular polygon with infinitely small sides.

The assumption that a curve is identical with an infinitangular polygons, or 'principle of the linearization of curves' was common among early modern mathematicians,⁸⁹ and was adopted by Leibniz since his early mathematical considerations. Thus, already in Summer 1673, Leibniz conceived curves as: "... consisting of infinitely many straight lines or sides, which are like portions of the tangents joining two proximal points applied on the curve (or two points separated by a distance infinitely small between them)".⁹⁰

But this principle had a key role in the study of quadratures and rectification problems, since it allowed Leibniz to assert, in general, the homogeneity between a curvilinear and a rectilinear segment.

Leibniz took up on this issue in contemporary papers of a more philosophical tone, in which he discussed examples from the mathematical practice too. The tract *De infinitis parvis*, for instance, from March 1676, is particular instructive in order to understand Leibniz's foundational concern with considering a curve as an infinite-sided polygon. In these notes, Leibniz inquired the following problem: "One must examine if it is possible to prove, in problems of quadratures, that the difference [between the polygons inscribed to a curvilinear figure, ie a circle, and the figure itself] is not only infinitely small, but actually nothing".⁹¹ In fact, if a curve is approximated by a sequence of polygons with n sides of length s , whose vertices lie all on the curve, so that the length L of the curve is

⁸⁹Cf. Knobloch [1999b], p. 216.

⁹⁰AVII4, 40, p. 657: "... intelligi poterit constare ex infinitis lineis rectis velut lateribus, quae scilicet portiones sint tangentium, duas applicatas proximas (seu distantia infinite parva a se invicem remotas) iungentium". Leibniz maintained this very conception of a curve as an infinitangular polygon throughout his research on calculus, and expressed this idea with the terms of 'aequipollentia' or 'aequivalentia'. The term 'aequivalentia' appeared in the *Nova methodus*, published in *Acta Eruditorum* of october 1684; and the term 'aequipollentia' occurs, for instance, in *Additio ad schedam de dimensionibus figurarum inveniendis*, appeared in *Acta Eruditorum*, December 1684 (for a french translation, see Leibniz [1989], pp. 94, 111). As for other occurrences of Leibniz's lexicon, the term is polysemic: Leibniz employs it to denote a curve which bounds a figure (or the figure itself), which has area equal ("à un facteur multiplicatif près") to a given figure. In this sense, he also said that a circular segment is *aequipollens* to its corresponding *figura segmentorum* (for instance: AVII51, p. 567). See more references in AVII6 p. XXX.

⁹¹"Videndum exacte an demonstrari possit in quadraturis, quod differentia non tamen sit infinite parva, sed omnino nulla" (AVI3, 52, p. 434).

computed, by approximations, by the sum of the lengths of the n sides of the inscribed polygons, it can always be found an integer n such that the error $L - ns$ will be less than s . From this premiss, Leibniz concludes that if n goes to infinity, the difference $L - ns$ will be less than any assignable quantity, and the lengths s of the polygonal sides will be eventually nothing. How can a curve be considered as an infinite-sided polygon, and how its length can be computed, if each side forming the polygon ultimately reduced to 'nothing'?

We have already encountered a similar conceptual difficulty with Gregory. In fact, in the *VCHQ*, Gregory imagined (he employed the very word: '*imaginare*'. See *VCHQ*, p. 19) the sector of a conic, to which the sequences of inscribed and circumscribed polygons approach, identical with the couple of the last inscribed and circumscribed polygon. But he also warned that defining the sector as the last polygon was a *façon de parler* (I stress the use of the expression: '*ita loqui licet*', in *VCHQ*, p. 15), in order to describe a couple of polygons such that their difference can be taken less than any exhibited quantity.

Leibniz was particularly concerned with this problem, and further developed his insight in April 1676, in a tract titled *Numeri Infiniti* (I stress the temporal vicinity of these reflections with the writing of the *De quadratura arithmetica*, completed in September 1676, and with the reading of Gregory, which occurred during the same year):

Circulus aliaque id genus, Entia ficta sunt; ut polygonum, quolibet assignabilis maius, quasi hoc esset possibile. Itaque, cum aliquid de Circulo dicitur (...) intelligimus id verum esse de quolibet polygono, ita, ut aliquod sit polygonum, in quo error minor sit quovis assignato a , et aliud polygonum in quo error minor alio quolibet certo assignato b . Non vero erit polygonum, in quo is sit minor omnibus simul assignabilibus, a et b , etsi dici possit, ad tale ens quodammodo accedere polygona ordine.⁹²

The special example of the circle offers the clue in order to understand Leibniz's solution (or at least, the solution he gave in 1676) to the philosophical puzzle that arises from the

⁹²Tr. by R. Arthur: "The circle - as a polygon greater than any assignable, as if that were possible - is a fictive entity, and so are other things of that kind. So when something is said about the circle (...) we understand it to be true of any polygon such that there is some polygon in which the error is less than any assigned amount a , and another polygon in which the error is less than any other definite assigned amount b . However, there is no polygon in which the error is less than all assignable amounts a and b at the same time, even if it can be said that polygons somehow approach such an entity in order" (Leibniz [2001], p. 88-89).

‘principle of linearization of curves’. In the passage above, in fact, Leibniz is discussing the classical rounding-off method in order to approximate the circle by two sequences of inscribed and circumscribed polygons, that come nearly and nearly to the circle as the number of their sides increases. Leibniz’s position can be thus paraphrased: anything which may be predicated, *qua* magnitude,⁹³ of a circle C , holds for two polygons P and P' which satisfy, for any couples of quantities a and b , the following inequalities: $C - P < a$ and $P' - C < b$. In other words, a circle is conceivable as the ideal limit of a double increasing sequence of polygons inscribed and circumscribed to it. Such a ‘fictional’ limit, continues Leibniz, does not exist “in the nature of things”, because it would be equal to a polygon with null sides but, at the same time, “we can give expression to it” (“ferri tamen eius expressio potest”). In particular, as I will deal in the next section, geometers can meaningfully say that the unit circle has an area of π provided we understand, by this, that one can find approximations of π within any prescribed degree of accuracy.⁹⁴

8.5 The quadrature of the circle in numbers

8.5.1 Leibniz’s alternate series for $\frac{\pi}{4}$

Leibniz stressed, in *De quadratura arithmetica*, how the understanding of a curve as an infinitesimal polygon with infinitely small sides would open up a field for inventions (*inveniendi campus*) in the domain of quadratures and rectifications.⁹⁵ One of the outstanding example in the ‘new field of inventions’ in which Leibniz saw himself as a pioneer, was indeed the arithmetical quadrature of the circle and the rectification of the circumference by means of an infinite series of numbers.

Considering the formulas 8.4.4 and 8.4.5 of the previous section, Leibniz could immediately infer, for a circle with radius $BA = 1$, circumference \widehat{C} , and by setting $b = \frac{1}{2}$

⁹³Leibniz is not concerned, in this context, with circles (or with any other curve) as means of construction, but as magnitudes.

⁹⁴See in particular Leibniz [2011], p. lvi.

⁹⁵AVII6, 51, p. 586: “Sed malim id lectores suo potius experimento discere quam meis verbis, sentient autem quantus inveniendi campus pateat, ubi hoc unum recte perceperint, figuram curvilineam omnem nihil aliud quam polygonum laterum numero infinitorum, magnitudine infinite parvorum esse. Quod, si Cavalierius, imo ipse Cartesius satis considerassent, majora dedissent aut sperassent” (“But I’d rather that my readers learned it through their own essays than by my words, they will sense how vast a field of discovery will be open, when they had understood just this: that every curvilinear figure is nothing but a polygon of infinite sides in number, of infinitely small magnitude. If only Cavalieri, or Descartes himself had considered it enough, they would have achieved or hoped for greatest results”).

and $\widehat{AC}_2 = \frac{\pi}{2}$, the following proportion:⁹⁶

$$BA : \widehat{C} = 1 : \frac{4}{1} - \frac{4}{3} + \frac{4}{5} - \frac{4}{7} + \frac{4}{9} - \frac{4}{11} \dots \quad (8.5.1)$$

If we consider the square Q built on the unitary diameter of a circle C instead, we will have:⁹⁷

$$Q : C = 1 : \frac{1}{1} - \frac{1}{3} + \frac{1}{5} - \frac{1}{7} + \frac{1}{9} - \frac{1}{11} \dots \quad (8.5.2)$$

Leibniz obtained these results already in Autumn 1673,⁹⁸ and communicated them to Huygens in the course of the subsequent year. The series for the area of the circle was firstly enunciated in the manuscript now published as VII,6 N. 4 (p. 74), and later on expounded in a more elaborated form, in the french draft of the *De Quadratura Arithmetica* sent to Huygens in Autumn 1674.

In July 1674, Leibniz described his discovery in a letter to Oldenburg too, observing:

Alia mihi theoremata sunt, momenti non paulo majoris. Ex quibus illud inprimis mirabile est, cujus ope Area Circuli, vel sectoris ejus dati, exacte exprimi potest per Seriem quendam Numerorum rationalium continue productam in infinitum.⁹⁹

Few months later, Leibniz thus illustrated his arithmetical quadrature to Oldenburg again, remarking:

Nemo tamen dedit progressionem numerorum rationalium, cujus in infinitum continuatae summa sit exacte aequalis Circulo. Id vero mihi tandem feliciter successit, inveni enim Seriem Numerorum rationalium valde simplicem cujus Summa exacte aequantur Circumferentiae Circuli; posito Diametrum esse Unitatem (...) Ratio Diametri ad Circumferentiam, exacte a me exhiberi

⁹⁶Cf. for instance: AIII1, 39, p. 165; AVII6, 4, p. 74; 7, p. 89.

⁹⁷Cf. AIII1, 72, p. 339; 72, p. 345; 73, p. 356; AVII6, 51, p. 602.

⁹⁸See S. Probst, *Neues über Leibniz' Abhandlung zur Kreisquadratur*, in Hecht et al. [2008], p. 172.

⁹⁹LSG, I, p. 53: "I have other theorems, of much greater importance. One of them is admirable in the first stance, by whose aid the area of the circle, or of a given sector of it can be exactly expressed by an infinite series of rational numbers, continually produced to infinity".

potest per rationem, non quidem Numeri ad Numerum (id foret absolute invenisse); sed per rationem Numeri ad totam quamdam Seriem numerorum Rationalium...¹⁰⁰

As we can read above, Leibniz highly praised his own result, consisting in expressing the area of the circle (or the length of its circumference) with unitary diameter in an exact way, by an infinite series of rational numbers.

However, it was problematic, in Leibniz's eyes at least, to understand under which conditions the assertion that a certain infinite series is exactly equal to a finite quantity (like the area of a surface or the length of an arc) can be qualified as true. Probably since his inchoate studies in quadratures, started in 1673,¹⁰¹ Leibniz was led to inquire about the meaning of the equality between an infinite series, like the alternating series $1 - \frac{1}{3} + \frac{1}{5} - \frac{1}{7} \dots$ and a finite quantity, like the finite area of the circle. He gave voice to the same quandary in *De quadratura arithmetica* and, in a more outspoken tone, in the tract *Numeri infiniti* (April 1676). We read in the latter, in fact:

Executiendum adhuc, an et quatenus vera est, v.g. quadratum est ad circulum ut 1 ad $\frac{1}{1} - \frac{1}{3} + \frac{1}{5} - \frac{1}{7} + \frac{1}{9} - \frac{1}{11}$ etc. Nam cum dicitur etc. *in infinitum* intelligitur ultimus numerus non esse quidem numerorum maximus, is enim nullus, sed esse tamen infinitus. Sed quoniam non determinatur quomodo? Adijciendum enim aliquid, etiamsi numerus infinitus sumatur, ideo dicendum id non esse rigorose verum.¹⁰²

In order to understand Leibniz's concern with the ontological status of the last term ("*ultimus numerus*") of a series, evoked in the above passage, it should be mentioned the fact that, in *De quadratura arithmetica* (prop. 49), Leibniz had sketched a general

¹⁰⁰LSG, I, p. 55: "But no one has given a progression of rational numbers, whose sum, continued to infinity is exactly equal to the circle. It eventually occurred to me: in fact I found a very simple series of rational numbers, whose sum equals exactly the circumference of the circle; set the diameter equal to the unity (...) the proportion of the diameter to the circumference can be exactly exhibited by me via a ratio, not of a number to a number (this would mean to find it absolutely); but by a ratio of a number to a whole series of rational numbers".

¹⁰¹See Arthur [2006], p. 4.

¹⁰²"We must still investigate whether, and to what extent, the following is true, namely that the square is to the circle as 1 to $\frac{1}{1} - \frac{1}{3} + \frac{1}{5} - \frac{1}{7} + \frac{1}{9} - \frac{1}{11}$ etc. For when we say 'etc.' or 'to infinity', the last number is not really understood to be the greatest number, for there isn't one, but it is still understood to be infinite. But as the series is not bounded, how can this be the case? For something must be added, even if it is assumed to be an infinite number, so that it must be said that this (equation) is not rigorously true" AVI3, 69, p. 502.

convergence criterion¹⁰³ for alternate series, that would be later developed in the test known as ‘alternating series test’.

The core of Leibniz’s argument consists in showing that in a series $s = a_1 - a_2 + a_3 \pm \dots$ such that the terms a_i become smaller than any given quantity (reverting to a modern terminology, we would say that the sequence: $a_1, a_2, a_3 \dots$ is monotonically decreasing), the partial sums with odd numbers of terms (namely: $S_{2m+1} = \sum_{n=1}^{n=2m+1} (-1)^{n-1} a_n$) and the partial sums with even numbers (namely: $S_{2m} = \sum_{n=0}^{n=2m} (-1)^{n-1} a_n$) tend to the same finite quantity, as n increases.

This criterion of convergence is explicitly applied to the series: $1 - \frac{1}{3} + \frac{1}{5} - \frac{1}{7} \dots$ in an article appeared in 1682, *De Vera Proportione Circuli*, where Leibniz published for the first time his series for the quadrature of the circle (it is plausible, however, that Leibniz had known or conjectured this result from his parisian years). In the *De Vera Proportione Circuli*, Leibniz deployed an argument in order to show that the series $1 - \frac{1}{3} + \frac{1}{5} - \frac{1}{7} \dots$ was equal to a certain finite quantity, that I have named \wp and can be identified with the measure of the surface of a circle with unitary diameter.

Leibniz justified this claim by observing that if we take the first term of the series, then \wp will be approximated with an error less than $\frac{1}{3}$; if we take the first two terms, then the limit-sum is approximated with an error less than $\frac{1}{5}$; if we take the first three term, then it is approximated with an error less than $\frac{1}{7}$, and so on. If the series is continued, one can obtain, after n terms, a partial sum $s_n = \sum_{k=1}^{k=n} (-1)^{k+1} a_k$ which offers a rational approximation to \wp , such that the remainder (in absolute value) is always smaller than the last term of the partial sum. Hence, the more terms we take the less the error becomes.¹⁰⁴

Let us point out, with..., that Leibniz envisaged a convergent series as an ordered sequence of terms. Thus, in the finite series: $1 - \frac{1}{3} + \frac{1}{5}$, 1 is the first term, $\frac{1}{3}$ the second, $\frac{1}{5}$ the third and last one. But, if we extrapolate from the situation of finite series to that of infinite ones (like: $\frac{1}{1} - \frac{1}{3} + \frac{1}{5} - \frac{1}{7} + \frac{1}{9} - \frac{1}{11}$ etc.), saying that the series is infinite and

¹⁰³Knobloch [2006], p. 125, Ferraro and Panza [2003], p. 21. By ‘convergence’, I understand here the property of a series which offers a close approximation of a certain quantity, when a convenient number of their terms is considered. This idea of convergent series, at least in Leibniz’s case, was probably moulded on the archimedean model of polygons squeezing the circle in the space of geometrical magnitudes.

¹⁰⁴Leibniz [1682], also in LSG5, p. 120. See also: Leibniz [1989], p. 77.

yet ‘bounded’, is tantamount to saying, in Leibniz’s view, that the series possesses an ‘infinieth last’ (“*numerorum maximus*”) number.¹⁰⁵

As I will expound later on, the postulation of a last term of an infinite (convergent) series was crucial in Leibniz’s way of handling series. However, such a postulation contradicts the fact that a convergent series always admits a smaller remainder (in absolute value) than the last term. Hence, in order to justify the truth of the assertion: ‘the (sum of the) infinite series $1 - \frac{1}{3} + \frac{1}{5} - \frac{1}{7} + \dots$ is equal to the finite quantity \wp ’, Leibniz explains that the expression: ‘sum of an infinite series’ should be paraphrased in this way:

Quandocumque dicitur seriei cuiusdam infinitae numerorum dari summam, nihil aliud dici arbitror, quam seriei finitae cuiuslibet eadem regula summam dari, and semper decrescere errorem, crescente serie, ut fiat tam parvus quam velimus.¹⁰⁶

Leibniz follows the same line of reasoning adopted in his considerations about the identity between curves and infinite-sided polygonal lines: a finite quantity l is *exactly* equal to the sum of an infinite series $\sum_{n=0}^{n=\infty} a_n$ when the difference between l and any finite series obtained by truncating the infinite expression: $a_1 + a_2 + a_3 \dots$, at an arbitrary position, can be made as small as we please.¹⁰⁷ Analogously, the series: $1 - \frac{1}{3} + \frac{1}{5} - \frac{1}{7} \dots$ is exactly equal to a finite quantity, namely the area of a circle with unitary diameter because the error becomes less than any given quantity. In this way, the whole series contains all approximations and expresses the exact value of the area of the circle.¹⁰⁸

¹⁰⁵Leibniz qualifies, in the above passage, the last term as: “*numerorum maximus*”, without reference to the magnitude, since the last term would be infinitesimal (the sequence of the terms being monotonically decreasing in absolute value), but referring to the ordinal position in the series: in other words, Leibniz is considering here the ‘infinieth’ term of the series. See in particular Levey [1998], p. 72ff, and Leibniz [2001], p. lvi.

¹⁰⁶AVI3, p. 503: “Whenever it is said that a certain infinite series of numbers has a sum I am of the opinion that all that is being said is that any finite series with the same rule has a sum, and that the error always diminishes as the series increases, so that it becomes as small as we would like”.

¹⁰⁷I point out that Leibniz’s argument contains two fundamental ideas which anticipate the modern concept of the sum of a series, understood as the limit to which the sequence $\{s_1, s_2, s_3 \dots\}$ of its partial sums ($s_1 = a_1$, $s_2 = a_1 + a_2$, $s_3 = a_1 + a_2 + a_3$, and so on) converges. Firstly, the partial sums constitute better approximations of the limit-term l as we increase the number of terms, without ever reaching the limit nor surpassing it; secondly, the difference between the limit and the successive terms in the sequence becomes smaller than any rational number one may mention: in other words, “the error always diminishes as the series increases” (See Levey [1998], p. 81). The same article contains an insightful discussion (not in my purview here) about the philosophical implications of Leibniz’s consideration on the ‘syncategorematic’ infinity involved in his discussion about series. I understand, for a sequence of terms to be ‘syncategorematically’ infinite, the fact that there are ‘more terms than one can specify’ (see also Arthur [2006], p. 4).

¹⁰⁸Cf. also Leibniz [1682], or LSG5, p. 120.

As we can read in a draft version of his treatise on the arithmetical quadrature of the circle, written in 1675 and intended for Gallois, Leibniz was aware the infinite series can be taken to express the area of the circle, in the same way as the sum of the series:

$$1 + \frac{1}{2} - \frac{1}{4 \cdot 3} - \frac{1}{8 \cdot 3 \cdot 17} \dots$$

could be taken to express the number $\sqrt{2}$.¹⁰⁹ In both the cases above and the one related to the quadrature of the circle, the relative series do not merely express numerical approximations to given geometric magnitudes, like the area of the circle or the diagonal of the square, but they define these magnitudes by means of rational numbers only.¹¹⁰

Yet, a difference remains between the series which expresses the diagonal of the square and the series which expresses the area of the circle. In the former case, the limit of the series is equal to a known number, it is in fact the irrational number $\sqrt{2}$.

On the contrary, Leibniz, as well as his contemporaries, ignored whether the limit of the series: $1 - \frac{1}{3} + \frac{1}{5} - \frac{1}{7} \dots$ were a rational number (thus belonging to the space of the series), a number expressible from given number by means of a finite sequence of algebraic operations or still a number non expressible in any known way (as it effectively is). As Leibniz remarked in a tract from October 1674:

Nescio an detur aut dari possit numerus aequalis seriei infinitae \oint [i.e. the series for $\frac{\pi}{4}$]. Interim scio aream circuli aequalem esse huic seriei infinitae.¹¹¹

¹⁰⁹AIII1, 73, p. 357: "Car effectivement il n'y a que les nombres entiers qui ne soient effectivement traitables par le calcul, et sans le secours des lignes, on ne saurait entendre ce que c'est un nombre irrationnel, qu'en trouvant qu'il est égale à un nombre infini de nombres rationaux. De sorte qu'on peut dire, que la raison en nombres du Diametre à la Circonférence est a present aussy connue a notre esprit que la Raison en nombres de $\sqrt{2}$ a 1, c'est à dire de la diagonale au costé du quarré". J. E. Hofmann remarks that the special series for $\sqrt{2}$ mentioned above was obtained by Leibniz in 1674 (it can be found in VII, 3, 38₁₅, p. 519-520), by applying an approximate step-by step determination of square roots which: "has been traced back, for special cases, to the Babylonians; it is given in Hero's *Metrica* 1:8; the cossists of the sixteenth century took it over from Islamic sources who themselves may have been in the chain of tradition by way of India and Greece, or may well have re-invented the method independently" (Hofmann [2008], p. 130).

¹¹⁰Hofmann [2008], p. 197.

¹¹¹AVII6, 11 p. 111. "I ignore whether it will be given or it can be given a number equal to the infinite series \oint . In the meantime, I know that the area of the circle is equal to this infinite series".

In fact, Leibniz had no elements to exclude that the sum of the series $1 - \frac{1}{3} + \frac{1}{5} - \frac{1}{7} \dots$ could be equal to a rational or a known algebraic number (for instance, a surd number).

This possibility was ventured by Huygens, for instance, who favorably commented upon Leibniz's arithmetical quadrature, in November 1674:

Je vous renvoie, Monsieur, Vostre escrit touchant la Quadrature Arithmetique, que je trouve fort belle et fort heureuse. Et ce n'est pas peu à mon avis d'avoir decouvert, dans un Probleme qui a exercè tant d'esprits, une voye nouvelle qui semble donner quelque esperance de parvenir a sa veritable solution. Car le Cercle, suivant vostre invention estant a son quarrè circonscrit comme la suite infinie de fractions $\frac{1}{1} - \frac{1}{3} + \frac{1}{5} - \frac{1}{7} + \frac{1}{9} - \frac{1}{11}$ etc. à l'unitè, il ne paroitra pas impossible de donner la somme de cette progression ni par consequent la quadrature du cercle, apres que vous aurez fait voir que vous avez determinè les sommes de plusieurs autres progressions qui semblent de mesme nature. Mais quand mesme l'impossibilitè seroit insurmontable dans celle dont il s'agit, vous ne laisserez pas d'avoir trouvé une proprietè du cercle tres remarquable, ce qui sera celebre a jamais parmi les geometres.¹¹²

Huygens judged Leibniz's arithmetical quadrature of the circle as "a new way for the true solution of the problem". It is likely, as suggested by Hoffman (Hofmann [2008], p. 82), that Huygens envisaged the concrete possibility of working on Leibniz's series in order to find the "true quadrature of the circle",¹¹³ namely the value of the area of the circle in terms of a rational or irrational algebraic number, which would demote Gregory's opposite conviction that the quadrature could not be solved analytically.

Leibniz had no elements to deny that the limit was analytical with the terms of the series, and for some time he probably shared Huygens' opinion. Indeed manuscript evidence shows that in the years 1673-74 Leibniz tried to extrapolate, from his studies on diverse numerical progressions, methods in order to calculate the sum of the converging series:

¹¹²Huygens [1888-1950], 7, p. 393-394.

¹¹³The expression "true quadrature" of the circle returns in the correspondence between C.A. Walter and Leibniz (cf. the letter from 22 September 1676, AIII1, 93, p. 603). The former observes: "la proportion du cercle par un nombre radical [namely the ratio between a circle and the squared built on its unitary radius, or diameter, expressed by a finite chain of algebraic operations on known rational or irrational numbers], comme on fait dans les lignes incommensurables (...) ce seroit la vraye cadrature du cercle" (AIII1, p. 604).

$1 - \frac{1}{3} + \frac{1}{5} - \frac{1}{7} \dots$. Leibniz's inchoate studies on summation of series¹¹⁴ concerned very special cases, namely successions (either finite or infinite) whose terms can be recognized as differences between successive terms of other sequences. An exemplary case studied by Leibniz is the finite series: $a_1, a_2, a_3 \dots a_n$, such that: $a_1 = b_1 - b_2$, $a_2 = b_2 - b_3$, $a_n = b_n - b_{n+1}$, where b_1, \dots, b_{n+1} are the terms of a second series, monotonically decreasing).¹¹⁵ Leibniz proved that, for any finite sequence $a_1, a_2, a_3 \dots a_n$, to which we can associate a finite sequence $b_1, b_2 \dots b_{n+1}$ ($a_1 = b_1 - b_2, a_2 = b_2 - b_3, a_n = b_n - b_{n+1}$), the following result holds:

$$a_1 + a_2 + \dots a_n = b_1 - b_{n+1}.$$

This elementary theorem states that the sum of the consecutive terms in a 'difference sequence' $a_1, a_2, a_3 \dots a_n$ is equal to the difference of the first and last term of the 'base sequence' $b_1, b_2 \dots b_{n+1}$. This result was extrapolated to the case of infinite sequences: this move eventually led Leibniz to find, in 1672, the series of the reciprocal of triangular numbers, namely: $\sum_{n=1}^{\infty} \frac{2}{n(n+1)} = 2$, as well to treat other series in likewise manner.¹¹⁶

Leibniz was probably convinced, on the aftermath of his discovery of the series for the arithmetical quadrature of the circle, that this series, or a series extrapolated for it might represent a 'difference sequence' of a still unknown base sequence, so that the limit of $\sum_{n=0}^{\infty} \frac{(-1)^n}{2n+1}$ might be obtained by applying the general theorem on difference series (or

¹¹⁴Most of his first results on the topic (see note 116 below, for an example) were incorporated in the tract *Accessio ad arithmetica infinitorum*, prepared for Jean Gallois, at the end of 1672, for an eventual publication on the *Journal des Sçavants*, whose editor was Gallois himself. The publication never occurred, so that the *Accessio* remained unpublished during Leibniz's lifetime (AIII1, 2, p. 2ff.). In order to give an idea of the extent and fecundity of Leibniz's study on progressions and series, which went hand in hand with his research into the quadrature of the circle, I will address to the rich collection of manuscripts published in volume AVII3, containing Leibniz's studies on series in the period 1672-76. Finally, the early studies on series are considered in Costabel [1978], and further discussed, in the light of new manuscript evidence, in Probst [2006a] and in Arthur [2006]. A general overview can be found also in Ferraro [2008], the chapter 2 in particular.

¹¹⁵See Hofmann [2008], chapter 2.

¹¹⁶*Cf.* Hofmann [2008], chapter 2, p. 18 in particular. I point out that the problem of calculating the sum of the series $\sum_{n=1}^{\infty} \frac{2}{n(n+1)}$, suggested by Huygens to Leibniz, had been solved by Huygens since the 60s (Huygens [1888-1950], vol. 14, p. 50-91). Therefore, it might have been proposed by Huygens as a test in order to assess the ability of the young mathematician. Leibniz found that the reciprocal of the triangular numbers, namely: $\frac{2}{i(i+1)}$ satisfy the following equality: $\frac{2}{i(i+1)} = \frac{2}{i} - \frac{2}{i+1}$, so that, applying the theorem on difference sequences he found: $1 + \frac{1}{3} + \frac{1}{6} + \dots + \frac{2}{n(n+1)} = 2 - \frac{2}{n+1}$, and derived, the sum of the infinite series of triangular numbers, namely: $1 + \frac{1}{3} + \frac{1}{6} + \dots = 2$. Leibniz's manipulation of series often led to true results, even if their deduction may not always carry conviction to us, because of his somewhat loose handling of divergent series, and the problematic ontological status of the last term in an infinite series (Hofmann [2008], p. 18).

sequences) stated above. I shall not insist on Leibniz's inquiries into the sum of the series for the quadrature of the circle, since they were soon abandoned.¹¹⁷ It is worth noticing though, that despite the failed attempts to calculate the area of the circle with unitary diameter, Leibniz maintained the confidence that his series for the quadrature of the circle was the 'royal highway' towards a finite solution of the circle squaring problem.¹¹⁸

8.5.2 Oldenburg's objections and the classification of quadratures

Counter to Huygens' encouraging response, Oldenburg answered to Leibniz's letters announcing the discovery of a series for the arithmetical quadrature of the circle in a less forthcoming way. Indeed Oldenburg suggested that Leibniz should consider more carefully whether he had achieved an 'exact' quadrature, alerting him with these words:

De eo quidem tibi gratulor, sed adjungam oportet, quod nuper a viro de rebus his sollicito accepi: Supradictum, nempe Gregorium, in eo jam esse, ut scripto probet exactitudinem illam obtineri non posse. Quod tamen minime a me dictum velim, ut ingenium studiumque Tuum sufflaminem, sed pro meo in Te affectu cautum reddam, ut talia scil. probe Tecum volvas revolvisque priusquam praelo divulges.¹¹⁹

The reference to Gregory was perhaps inspired by the circumstance that the latter was then preparing an improved version of the *VCHQ* (which has not come down to us, unfortunately); therefore Oldenburg might have fresh knowledge about Gregory's result contained in *VCHQ*.

One of the main points at stake in the exchange between Oldenburg and Leibniz concerns the meaning of 'exact', with respect to problems of quadratures. In a subsequent letter

¹¹⁷Examples can be found in AVII3, 15, p. 180; AVII3, 38₁₀.

¹¹⁸AVII6, 7, p. 91: "Je crois que ceux qui entendent la matiere demeureront d'accord que c'est peut estre le premier Moyen, qu'on ait donné pour arriver à la Quadrature Geometrique du Cercle; et que même la moitié du chemin estant faite, il y a grande apparence, si elle se trouvera jamais, que ce sera par cette voye." See also the *Scholium* (AIII, 1, 39, p. 165ff.) of the draft for La Roque: "S'il y a lieu d'esperer qu'on pourra jamais arriver à une raison analytique; exprimée en termes finis, du Diamètre à la Circonference, je croys que ce sera par cette voye. Car quoyque les expressions soyent infinies, nous ne laissons pas quelque fois d'en trouver les sommes" (AIII, 1, 72, p. 351).

¹¹⁹This letter dates from 18th December 1674. LSG, I, p. 57: "I need to add what I have recently learned from a man well-versed in these subjects: the latter, namely Gregory, had already stumbled upon this question, so that he proved that such exactness cannot be obtained [i.e. an exact quadrature of the circle cannot be obtained]. But I wish you may take my words not in order to impede you, but as an invitation, out of my affection for you, for your talent and study to proceed with care, so that you may ponder these matters well within yourself, before divulging them for publication".

to Oldenburg, from March 1675,¹²⁰ Leibniz pointed out that Gregory's impossibility result, even if correct, did not entail the impossibility of finding an exact quadrature of the circle. Let us recall, in fact, that Leibniz held that the sum of the infinite series $\frac{1}{1} - \frac{1}{3} + \frac{1}{5} - \frac{1}{7} + \frac{1}{9} - \frac{1}{11} \dots$ was *exactly* equal to the area of the circle if and only if the error between such a supposed magnitude and any finite subseries can be made smaller than any given number. On the contrary, Gregory's assertion about the analytical (defined by Leibniz: "exacta penitus et geometrica") impossibility of the quadrature of the circle implied that the area of the circle could not be expressed as a number obtained by applying algebraic operations on known numbers, as Leibniz neatly pointed out:

Gregorius enim non hujus quidem quadraturae generis, quod arithmeticum appellare soleo, per series numerorum rationalium infinitas, sed exacti penitus et geometrici per unum quendam numerum aut finitam numerorum seriem, sive illi rationales, sive irrationales sint, impossibilitatem a se demonstratam putavit, quod meo invento nihil adversatur.¹²¹

Leibniz was particularly concerned with the problem of clarifying the meaning of exactness in the context of the circle-squaring problem, as revealed by one of the drafts of the letter prepared for Oldenburg, but never sent nor completed.¹²²

Possibly as a reaction to Oldenburg's misgiven objection, in fact, Leibniz set out to deploy a general hierarchy in order to countenance several "*gradus*" (levels) of quadratures, ranged from the least to the most exact one.¹²³

Leibniz ranged, at the lowest level, what he called 'approximate quadratures', namely quadratures solved by approximation processes, either numerical or geometrical. Among the approximate 'numerical' quadratures, Leibniz mentioned the classical Archimedean

¹²⁰The letter is now extant in three versions (see AIII, 46, n. 1, 2 and 3, p. 201ff.). Only the version n. 3 was sent to Oldenburg.

¹²¹LSG, I, p. 59: "Indeed, Gregory reckoned to have proved the impossibility not of this kind of quadrature, that I am used to calling arithmetical, obtained by an infinite series of rational numbers, but of the fully exact and geometrical one, by one number, or a finite series of numbers, rational or irrational, which is not against my discovery.". See also Hofmann [2008], p. 116, 127.

¹²²See AIII46, n. 2.

¹²³An analogous classification of quadratures is discussed also in the tract, written in 1676, *Praefatio opusculi de Quadratura Circuli Arithmetica* (AVII6 19, p. 176-177), written one year later. Leibniz probably intended to present in the 1676 work the achievement of a series of methodological considerations on quadratures that he had been elaborating for the previous two years. Leibniz resumed a classification of quadratures also in the *De Vera Proportionione Circuli ad Quadratum in Numeris Rationalibus Expressa*, published in 1682 (Leibniz [1682], also in LSG5, p. 120).

technique of approximation, Ludolph van Ceulen's *Fundamenta arithmetica et geometrica* (1615), and, finally John Wallis' *Arithmetica Infinitorum* (1656), among early modern representatives of approximate quadratures.¹²⁴ 'Linear' quadratures consist of approximated constructions obtained by ruler and compass: Leibniz evokes on this concern Willebrod Snell's *Cyclometria* (1621) and Christiaan Huygens' *De circuli magnitudine inventa* (1654).¹²⁵

After the class of approximate and linear quadratures, Leibniz introduces 'mechanical' ones in these terms:

Proxima est mechanica, quae exacta esse potest, sed perficitur ope curvarum quarundam materialium mensurae cuidam applicatarum, ut per evolutione filii; curvae materiali circumplecti, aut provolutione curvae materialis in plano, aut applicatione regulae ad curvam materialem inveniendae tangentis causa; talis est dimensio circuli aut arcus circularis per cycloidem, aut per tangentem spiralis Archimedaeae.¹²⁶

Leibniz stresses that mechanical quadratures are those ones solvable via curves generated out of special motions and explicitly ruled out by Descartes, like the spiral and the cycloid, or else, curves traced by revolving a string around some material objects.¹²⁷

¹²⁴Leibniz maintained that Wallis's "expression" was good for approximations, "but cannot be considered as an exact expression, taken as a whole" ("sed non pro exacta expressione per infinitam seriem considerata semel in universum", *De serie Wallisiana*, 1676, AVII, 3, p. 824). Generally speaking, Leibniz expresses doubts about the convergence of Wallis' sequence (Probst [2004], p. 192), on one hand, and on the other he disapproves of Wallis' inductive procedure, which relies, according to Leibniz, too heavily on intuition. Generally speaking, Leibniz characterized Wallis' method of quadratures as being still dependent on intuition and on a classical approach: "Mr Wallis, in order to make his investigations easier, gives us by means of induction the sums of certain rows of numbers, whereas the new analysis of infinites considers neither figures nor numbers but quantities in general, as does ordinary algebra" (This excerpt, translated by P. Beeley, comes from a later text of 1692, *De la Chaînette*. Similar opinions are extant in earlier texts, dating from the parisian period. Cf. for instance: *De progressionibus et de arithmetica infinitorum*, A VII3, p. 102).

¹²⁵Huygens [1888-1950], vol. 12, p. 131.

¹²⁶AIII, 46, p. 203: "The subsequent class is the mechanical one, which can be exact, but it is effected by means of material curves applied to a length, as through the evolution of a chord, wrapped around a material curve, or through the rolling of a material curve in the plane, or applying a rule in order to find the tangent to a material curve. This is the rectification of the circle or of a circular arc by the cycloid, or by the tangent to the archimedean spiral".

¹²⁷Leibniz was arguably thinking of the theory of evolutes which he had come to know through the third book of Huygens' *Horologium Oscillatorium* (Leibniz's annotations to Huygen's *Horologium* dated back to Spring 1673, as shown in AVII4, n. 2). The dual notions of evolute and involute were introduced by Huygens by describing the following physical device. Huygens demands to consider a smooth curve without cusps or changes in its concavity, and to imagine a taut string wrapping a part of the curve or the whole curve, while it is constrained at one extremity. If the string is then tightly unwrapped

Such ‘mechanical’ quadratures, Leibniz insists, can be considered ‘exact’. Leibniz was possibly suggesting that these quadratures were obtained by ‘exact’ curves, certainly on the ground of a different ideal than the one in force in Cartesian geometry, which rejected mechanical curves. It is by no means evident here, though, to understand the criterion arguably adopted by Leibniz in order to consider exact, and therefore geometrical, curves like the spiral, the cycloid and the evolutes, generated by physical devices. The context of Leibniz’s exploration in the theory of curves may help us here, though. Later on, in section 8.9, I shall come back on this theme, in order to venture some hypothesis on the exact and geometrical nature of certain non-cartesian curves.

The standard of exactness Leibniz has here in mind is not clearly specified in the letter. Certainly, it is sufficient to consider that Leibniz is discussing quadratures obtained through mechanical curves, in order to exclude that he is referring to the exactness as conceived by Descartes, in his geometry.

starting from the free extremity, this motion will trace another curve, called "involute" of the given curve, or, in Huygens’ terminology, the curve described by evolution. The curve around which the chord is wrapped is called, on the other hand, "evolute" (this corresponds to the fourth definition contained in the *Horologium Oscillatorium*). It is implicit in this procedure that a given evolute can be associated to an infinite number of involutes, since Huygens assumes that the string has an arbitrary length, and its extremity can coincide with any point on the initial curve (Huygens [1888-1950], vol. XVIII, p. 189). The very construction of the involute reveals a property of the curve which is rigorously proved in the *Horologium*: the tangents to any point of an evolute are by construction normals to the involute. Hence, the evolute can be defined as the envelope of all the normals to an involute. This property offered to Huygens the ground for the determination of the evolute, as a locus which could be described analytically if the involute was a geometrical curve itself. Hence, in order to construct a point on the evolute, Huygens considered on the given involute two points at infinitely close distance, and, having traced their normals, he marked their intersection point (the normals intersect provided the original curve is not a straight line). Proceeding in this way for an arbitrary number of points, a locus could be pointwise constructed, which is the evolute of the given curve (this is the construction called "artificial" by Leibniz, in the above passage, probably because it could not be supplied by a continuous tracing through an instrument). A second property studied by Huygens was crucial to Leibniz’s argument: the generation of the evolute from a given curve provides also its rectification. This property is intuitive if we consider the generation of the involute by means of a string: since the string is supposed tightly adhering to the curve, as a part of the string unwraps, a part of the curve (namely the evolute) on which the string was lying is rectified. Therefore, if an evolute is given, the construction of one of its involute rectifies also the evolute or part of the evolute itself. However, Leibniz saw an obvious inconvenient to the use of the related couple evolute/involute in order to solve the general problem of the rectification of curves. Indeed, the construction of the evolute from a given curve solved, via a construction, also the problem of its own rectification, but not the rectification of the companion curve. Huygens’ work on the evolutes failed to provide a reverse analytical technique for finding the equation of the involute given its evolute. The case of the circle is salient on this concern, since its involute could be described by Huygens only "qualitatively", let us say, as the result of a geometrical construction, but not analytically via an equation (See Yoder [1988], p. 93).

'Arithmetical' quadratures come next in Leibniz's classificatory scheme. Leibniz does recall that Mercator has obtained an arithmetical quadrature of the hyperbola, but insists in claiming for himself the priority in the discovery of the quadrature of any circular sector, and of the circle too. The arithmetical quadrature of the circle, Leibniz stresses, is somehow the apex of possible quadratures discovered thus far, as it: "exhibits not a number, but an infinite series of numbers exactly equal to the sought-for magnitude ...".¹²⁸

The arithmetical quadrature of the circle, Leibniz emphasized, in the draft of another letter from 1675, probably intended for Gallois (AIII1, 73), consisted of a result fundamentally different than a geometrical quadrature, since it did not directly come up with a rule in order to exhibit, by a geometric construction in a finite number of steps, a square equal to a given circle.¹²⁹

However, even without knowing whether the limit of the infinite series: $\sum_{n=0}^{\infty} \frac{(-1)^n}{2n+1}$ could be expressed by a known, algebraic number, Leibniz was convinced that the series itself offered, uniquely in virtue of its law of formation, an epistemic access to the nature of the ratio between a circle and the square built on its diameter. Thus, Leibniz judged his arithmetical quadrature as the "true quadrature of the circle in numbers", remarking:

... qua nescio an simplicior dari possit, quaeque mentem aciat magis. Hactenus appropinquationes tantum proditae sunt, verus autem valor nemini quod sciam visus nec a quoquam aequatione exacta comprehensus est, quam hoc loco damus, licet infinitam, satis tamen cognitam, quoniam simplicissima progressionem constantem uno velut ictu mens.¹³⁰

This suggestive passage relates the simplicity of the alternating series for the quadrature of the circle to the immediacy through which its unique law of formation can be seized and represented through an adequate symbolism (*uno ictu mens*). The possibility of expressing such a law of formation, by means of a description involving only a finite

¹²⁸"Sequitur quadratura arithmetica, qui exhibetur magnitudini quaesitae exacte aequalis non numerus quidem, sed series numerorum infinita ...", AIII1, 46, p. 203.

¹²⁹"Quadrature arithmetique (...) n'est pas geometrique, car je ne pretends pas decrire un quarré egale à un cercle", AIII1, 73, p. 356.

¹³⁰AVII6, 51 p. 601: "I do not know if it is possible to give a simpler one [i.e simpler than the series: $\sum_{n=0}^{\infty} \frac{(-1)^n}{2n+1}$], and one which impresses more the mind. So far, only approximations have been given, but no one seems, to my knowledge, to have seen and understood its true value by means of an exact equation, which i give here, although infinite, nevertheless sufficiently known, since the mind pervades it all, as if through a single stroke, thanks to the extremely simple progression".

number of words, grounds our intellectual grasp of an infinite object, like the series under examination, and consequently our intellectual grasp of the nature of the ratio between the circle and the square constructed on its diameter, in modern terms, our understanding of π .¹³¹

Arithmetical quadratures ought be distinguished not only from geometrical ones, but also from ‘analytical’ quadratures. An ‘analytical quadrature’ of the whole circle, or of one of its sectors, obtains when one can express the ratio between the circle (resp. a sector) and an inscribed or circumscribed polygon through a number, rational or surd: Leibniz probably intended a number obtained by composing positive numbers by the known algebraic operations.

But Leibniz also pointed out, in the 1675 draft for Oldenburg, to another kind of analytical quadratures, whose result is exhibited: "through an expression of the kind of those that I call transcendental" ("per expressionem quandam ex earum genere, quas ego appello transcendentas").¹³²

This last remark, which is not further developed in the draft to Oldenburg,¹³³ is certainly worth of a commentary. It seems, at a first reading, that Leibniz might want to venture the idea that equations of a different kind than those promoted by Viète and Descartes could possibly express the relation between circular and rectilinear magnitudes. But which kind of equations?

The consideration of contemporary texts reveals that the term ‘transcendental’, at least in Leibniz’s early mathematical production, generally denoted problems and curves irreducible to algebraic equations.¹³⁴ However, Leibniz also gave a positive characterization

¹³¹Cf. Granger [1981], p. 17ff. See also Debuiche [2013], p. 422ff. Leibniz, who probably examined several series discovered up to his time in order to determine π , as his catalogues of quadrature reveal (one example is contained in the draft of the letter to Oldenburg, examined above), did not find in any among the known results the virtues of his series. This conclusion may seem to us excessively severe. Without entering into the study of the methods for the computation of π , it is sufficient to think of Wallis’ series presented in the *Arithmetica infinitorum* as an infinite series of rational numbers which defines, just like Leibniz’s series, the ratio between the circle and the square built on the diameter, and can be understood in virtue of its law of formation. However, as discussed before, Leibniz saw a crucial difference in method between his investigation and Wallis’ arithmetical quadrature.

¹³²AIII1, 46 p. 203-204.

¹³³Leibniz probably decided to drop these allusions to ‘transcendental’ equations in the copy of the letter eventually sent to Oldenburg, possibly fearing that his remark was not sufficiently developed, and therefore may result obscure (see Breger [1986], p. 122).

¹³⁴More precisely, in his 1674-76 production, Leibniz employed the expressions: "*Figura transcendens*", "*curva transcendens*", "*problema transcendens*". The term ‘transcendental’ was employed by Leibniz

of transcendental equations. For instance, we can read in a draft of *De quadratura arithmetica*, written in 1676:

ope aequationis (transcendentis licet sive infinitae) calculi analytici institui possunt circa magnitudines, quae hactenus creditae sunt Calculo non subiectae.¹³⁵

In this passage, Leibniz refers to a new calculus performed by means of "transcendental equations" or "infinite equations". 'Infinite' equations presumably represented those relations between geometric objects, like a circular arc and its corresponding tangent, expressible by a (infinite) series. But what kind of objects did "transcendental equations" or "transcendental expressions" might have denoted?

Another excerpt from a letter to Oldenburg written in October 1676,¹³⁶ is perhaps useful in order to elucidate Leibniz's reference to "transcendental expressions" and "transcendental equations". In this letter, Leibniz attempts to derive an equation for the cycloid, and obtains the following "analytical expression" for a transcendental curve:

$$2v - 1 = \sqrt[\frac{\omega}{2}]{\pm \frac{b}{2} + \sqrt{\frac{b^2}{4} - 1}} + \sqrt[\frac{2\omega}{z}]{\pm \frac{b}{2} - \sqrt{\frac{b^2}{4} - 1}}$$

This equation relates the abscissa z and the ordinate v of a cycloid, generated by a rolling circle of radius 1, such that ω is a given arc, and b the corresponding chord.¹³⁷ I shall not explore here how Leibniz obtained this equation, but point out to the fact that this equation constitutes a new symbolic expression with respect to those treated by Descartes in *La Géométrie*. We can notice, indeed, that it contains the unknown z appearing at the index of the root.

from 1673 onwards, in order to denote curves, figures and problems non expressible by finite polynomial equations, like the logarithmic curve (see AVII3, *Introduction*, in particular p. XXIV, and *cf.* an early occurrence such as: AVII3, 23, p. 267.). The dating suggested by Parmentier in Leibniz [1989] (p. 65), who fixed the first use of the term to the draft of the letter to Oldenburg that we are examining, is therefore corrected.

¹³⁵AVII6, 28, p. 331: "By means of this equation (transcendental or infinite) analytical calculi can be effected about quantities that so far have been thought not subject to the calculus".

¹³⁶The letter is published in AIII1, 96.

¹³⁷AIII1, 96, p. 649.

Leibniz returned on similar considerations in the article: *De vera proportione circuli...* (1682). This paper was published much later than the period we are examining, but it is thematically close to the research led by Leibniz in the mid seventies. Moreover, it presents a classification of quadratures too. In connection with the issue here at stake, we read in the *De vera proportione circuli*: "An analytical transcendental is one of the quadratures obtained by an equation of indefinite degree, so far considered by noone, as when we let: $x^x + x = 30$, and x is searched, the result will be 3, because $3^3 + 3 = 27 + 3 = 30$: I will give such equations for the circle in due time)".¹³⁸ Leibniz was thus inquiring, in the 1682 article, whether an "analytical, transcendental quadrature" of the circle could be obtained by means of an 'indefinite equation', which was an open question, by that time (*Cf.* Leibniz [1989], p. 75).

These remarks, together with the example of the cycloid, may offer the ground for the conjecture that, by the words "transcendental expression", Leibniz was referring, already in his 1675-76 drafts to Oldenburg, to a finite equation of indefinite degree, in which the unknown appears as the index of a root, or as an exponent. Such an equation would be obviously different from a polynomial equation of the kind treated by Descartes, but it would be also different from an infinite equation, as the one expressing the arithmetical quadrature of the circle, since it would not be constituted by an actually infinite expression or equation, like the ones associated with the arithmetical quadrature of a circular sector. Hence, Leibniz might have introduced, in the draft of a letter to Oldenburg, a distinction into two kinds of 'analytical' expressions: one referring to algebraic expressions and equations, the other referring to transcendental expressions and equations. When referred to the outcome of a quadrature, analytical quadratures are distinct from an arithmetical one, since they consist of finite symbolic expressions. Meanwhile, while algebraic equations coincide with Descartes' and Viète's algebra, transcendental equations represent symbolic expressions of a new kind, a veritable "supplement of algebra", as Leibniz would later define it.¹³⁹

Let us return to the text of the draft to Oldenburg. A 'geometrical quadrature', Leibniz eventually points out, is the 'apex' of all quadratures, and it is obtained by a ruler and compass, or by a suitable composition of these instruments, namely: "regulis aut circinis

¹³⁸"Analytica transcendens, inter alia habetur per aequationes gradus indefiniti, hactenus a nemine consideratas, ut si sit $x^x + x$ aequal. 30, & quaeratur x , reperietur esse 3, quia $3^3 + 3$ est $27 + 3$ sive 30: quales aequationes pro circulo dabimus suo loco" (in Leibniz [2011], p. 9).

¹³⁹*Cf.*, for instance, LSG, V, p. 232.

inter se compositis seque compellentibus aut ducentibus".¹⁴⁰ We can read here a clear reference to geometric linkages, so that a 'geometrical quadrature' will be a quadrature solvable by curves acceptable in cartesian geometry. Analytical (algebraic) and geometrical quadrature are therefore closely connected, since if the algebraic quadrature of the circle could be discovered, then a geometrical quadrature could be obtained as well. Conversely, Leibniz ought to admit that if a quadrature could be solved geometrically, by constructing a square equal to a given circle through the intersection of curves traced by cartesian linkages, then the constructed square (or its side) would be the root of a finite polynomial equation too. The equivalence between algebraic and geometrical quadratures demands, as a necessary condition, to assume that curves constructable by geometric linkages can be always associated to finite algebraic equations, and *vice versa*, that algebraic equations can be associated to curves generated by legitimate linkages. As examined in chapter 3, this equivalence was assumed by Descartes as valid, and Leibniz did not contest it.

Even if the repertoire of quadratures sketched by Leibniz is not definitely distinguished and elaborated,¹⁴¹ arithmetical quadratures are clearly discriminated from analytical ones, and among the latter, quadratures reducible to finite polynomial equations (we may call them 'algebraic' quadratures in order to avoid ambiguities, although Leibniz does not employ, at least in his 1675-76 works, this term) are further distinguished from quadratures reducible to transcendental expressions. An arithmetical quadrature of the circle can be judged exact, according to Leibniz, and if the impossibility of the algebraic quadrature of the circle were eventually proved, the arithmetical quadrature of the circle should be considered the most exact quadrature attainable.

8.6 The impossibility of giving a universal quadrature of the circle

8.6.1 Leibniz's criticism of Gregory's arguments

In the drafts of his letters to Oldenburg from March 1675, Leibniz did not exclude that an algebraic quadrature of the whole circle might be found, against Oldenburg's own convictions. On this occasion, Leibniz unravels his dissatisfaction for Gregory's impossibility claims, expounded and argued in the *Vera Quadratura* and in the *Exercitationes*

¹⁴⁰AIII1, 46, p. 204: "...rulers and compasses intertwined and pushing and guiding each other".

¹⁴¹Hofmann [2008], p. 129.

Geometricae, mentioning how ‘new’ objections could be added to those already discussed by Huygens in the *Journal des Sçavans*.¹⁴²

These objections are not explicated in the draft from 1675, though. Some light on what Leibniz could have in mind might be thrown by examining few manuscripts written in 1676, which contain critical remarks towards Gregory’s arguments on the impossibility of giving an analytical (i.e. algebraic) quadrature of the central conic sections. The most prominent tracts, for our theme, are the following: *Quadraturae Circuli Arithmeticae Pars Secunda* (AVII6, n. 28, dated June or July 1676); *Series convergentes seu substitutrices* (AVII3, 60, from June 1676); *Series convergentes duae* (AVII3, 64, June 1676).

Let us observe that the tracts AVII6, 28, AVII3, 60 and 64 were also written while Leibniz was presumably elaborating his ultimate version of the *De Quadratura arithmetica*, the one including proposition LI. It can be supposed, therefore, that Leibniz’s work on the impossibility result later added as the last proposition of his treatise, occurred in the backdrop of an intense study of Gregory’s arguments for the impossibility of giving an indefinite and a definite quadrature of the circle.

A further confirmation of this hypothesis comes from the tract AVII6, 28, ‘*Quadraturae Circuli Arithmeticae Pars Secunda*’. As remarked in the introduction, this draft is closed by a proposition on the impossibility of giving a more geometrical quadrature of the central conic sections, which looks almost identical to proposition LI (AVII6, 51, p. 348-349), except for its conclusion. In fact Leibniz appended to the last proposition of AVII6, 28 a long critical *Scholium* occupied by a discussion about the impossibility results contained in the *Vera circuli et Hyperbolae Quadratura*. It is arguable that Leibniz intended to enrich the impossibility argument expounded in AVII6, 28 with additional

¹⁴²AIII1, 46, p. 204: "... praeter objectiones ab illustri Hugenio factas, quibus nondum est satisfactum universis, habeo et ego peculiare, unde satis judicari potest, nondum geometras ab hac inquisitione desistere debere" ("Besides the objections made by the celebrated Huygens, which do not yet satisfy everyone, I have peculiar objections too, from which one can adequately conclude that the geometers must not give this research up"). In another draft of the same letter, Leibniz invokes Huygens’ critiques (*rationes Hugenio intactae*) to Gregory - he presumably refers to the objections advanced by Huygens in the *Journal des Sçavans*, discussed in the previous chapter of this study - in order to endorse them. Finally, in a subsequent letter to Oldenburg, dating from 27 August 1676, Leibniz maintained his conviction that Gregory’s proofs of impossibility is imperfect and not fully rigorous, although the rationale behind this opinion is still left implicit ("Ceterum ejus demonstrationi editae de impossibilitate quadraturae absolutae circuli et hyperbolae multa haud dubie desunt", AIII1, 89, p. 580. In my translation: "Moreover, many things are without doubt lacking in his published proof of the impossibility of the absolute quadrature of the circle and the hyperbola").

critical remarks towards Gregory's impossibility claims. Hence, the discussion contained in AVII6 28 provides further evidence in order to claim for a link between Leibniz's impossibility arguments, developed firstly in AVII28 and later in AVII, 51, and his ongoing criticism to Gregory's claim to the impossibility of solving analytically the quadrature of central conic sections.

Let us consider in more detail Leibniz's examination of Gregory's arguments. Leibniz's examination begins by expounding Gregory's definition of convergent series and the strategy ("*vis argumenti*") deployed in *VCHQ* in order to prove the analytical impossibility of squaring a sector of the circle, once this problem has been reduced to the problem of finding the limit, or *terminatio*, of a certain succession.¹⁴³

Successively, Leibniz enters the *pars destruens* of his considerations. The first of Leibniz's criticisms concerns the claim that a sector of a central conic, freely chosen, is composed analytically from the inscribed and circumscribed polygons (*VCHQ*, XI, p. 27; and *Scholium* to proposition XI, p. 28). Leibniz acknowledged the correctness and ingeniousness of Gregorie's procedure for handling series ("*haec omnia pulcherrima sunt*"), but pointed out an alleged logical flaw ("*quodammodo in ratiocinandi forma peccasse*") in Gregory's reasoning leading to the impossibility of the analytical quadrature of an arbitrary sector.

Leibniz's objection moves from the examination of the concluding remarks of proposition X of the *Vera circuli et hyperbolae quadratura* (*VCHQ*, p. 23). In order to find the *terminatio* of a convergent series - Gregory argues there - it is sufficient ("*opus est solummodo*") Leibniz reports, quoting the original: see *VCHQ*, X, p. 24) to exhibit an invariant analytical composition with respect to the terms of the series and its *terminatio*. Leibniz concedes the correctness of this claim, but contests that Gregory has unjustifiedly concluded the reciprocal. So Leibniz remarks:

Si non possit dari hujusmodi formula analytica, non posse dari terminationem Seriei convergentis. Id tamen facit ille ...ponit ergo tacite, si non detur hujusmodi formula, non posse dari terminationem. Et hinc, inquit evidens est quod sector non componatur analytice ex triangulo inscripto et trapezio circumscripto. At consequentiam istam probare ne conatur quidem, usque

¹⁴³"Quadratura ergo Sectoris huc redit, ut inveniatur seriei convergentis terminatio."AVII6, n. 28, p. 350-351.

adeo claram creditit.¹⁴⁴

Leibniz interprets Gregory's proposition X as a sufficient condition in order to find the limit of a converging sequence to a conic sector (if one can find an invariant analytical composition of the convergent terms, then he can find the limit of the sequence), and objects that Gregory took this condition as necessary too, by tacitly assuming that: "if an invariant analytical composition of the first and second couple cannot be found, then the *terminatio* is not analytical with the terms of the convergent series", which is the reciprocal of the conclusion stated in proposition X.

In summary, Leibniz contests that Gregory grounded the analytical impossibility of the quadrature of an arbitrary sector of the circle, of the ellipse and of the hyperbola, on the following assumption: a convergent sequence tends to an analytical limit *only if* this limit can be found according to the method prescribed by Gregory (or that any method capable of computing the limit was eventually reducible to Gregory's procedure).

But this assumption, Leibniz objects against Gregory's tacit belief, is by no means evident, and requires a proof: Gregory's argument is therefore not fully justified.¹⁴⁵ I remark that this objection develops a critical note made by Huygens, in a letter from 2nd July 1668 (see previous chapter, for Gregory's replies), according to which the impossibility of the analytical quadrature of a central conic could not be deduced merely on the ground of the arguments deployed in proposition X and XI of *VCHQ*, unless one could add the 'only if' condition evoked above.

In the same tract AVII6, 28 and in the contemporary tract AVII3, 60 (p. 757), Leibniz discusses a second objection against Gregory's impossibility claims. Indeed, he observes, with reference to proposition XI of *VCHQ*:

Imo vero inquiet, demonstratum est, quoniam ostendimus non posse dari formulam analyticam ex a . et b . formatam, eodem modo quo ex $\sqrt{ab} \cdot \frac{2ab}{a+\sqrt{ab}}$.
Concedo. Si ergo non datur talis formula analytice composita; non datur

¹⁴⁴AVII6, 28, p. 353: "But Gregory must not derive the reciprocal: if such an analytical formula could not be given, then the limit of the convergent series cannot be exhibited. However, he does this... he tacitly assumed, if a formula of this kind is not given, then the limit cannot be given. But he does not even try to prove this consequence, that so far he believes to be clear".

¹⁴⁵Leibniz remarks that Gregory: "Does not even attempt to prove this conclusion, to the point that he believes it is clear" ("consequentiam istam probare ne conatur quidem, usque adeo claram creditit"), AVII6, 28, p. 354).

quantitas analytica per hanc formulam significata. Potest enim fieri ut quantitas sit analytica et nota, verbi gratia numerus; formula autem secundum quam illa eodem modo componitur ex terminis duobus primis quo ex duobus secundis poterit esse ignota et non analytica.¹⁴⁶

This objection may be related to the criticism raised by Wallis, and echoed by Huygens too, in two letters from 1668, that have been discussed in the previous chapter (*cf.* ch. 7, sec.7.5). I recall that, according to Wallis, Gregory's impossibility argument, even if sound, would not entail the impossibility of giving an analytical quadrature of the whole circle, or of one of its rational sectors. In fact, Gregory's proof concerned the impossibility of finding a (unique) analytical formula in order to square any given sector of a central conic. By analogy, the impossibility of trisecting an angle, argued Wallis, did not mean that no angle is trisectable by ruler and compass (as it was known since antiquity, there are angles perfectly trisectable by ruler and compass, like the right angle), but it meant that there is no a (unique) ruler and compass construction that allows one to trisect any given angle (or to trisect an angle, without information on its measure). In order to distinguish the impossibility of finding an analytic composition, in order to square any given sector of a circle (or of a central conic) from the impossibility of squaring a particular sector, Huygens coined the expressions: "indefinite quadrature" and "definite quadrature".

I suggest that this conceptual distinction and the reasoning lying in its backdrop can be also considered the gist of Leibniz's criticism expounded in the passage quoted above. In another, related tract, Leibniz remarked that Gregory's ungrounded claim to the impossibility of the analytical quadrature of the whole circle lies on a conceptual confusion between 'formulas' and 'quantities'.¹⁴⁷

¹⁴⁶"He [namely Gregory] will say that this is proved [i.e. that the sector is not analytical with the sequence of inscribed and circumscribed polygons] since an analytical formula formed by a and b , in the same way as from \sqrt{ab} and $\frac{2ab}{a+\sqrt{ab}}$ cannot be given. I concede this. But if such a formula, analytically composed, is not given, then an analytical quantity expressed by this formula is not given. It can be that the quantity is analytical and known, for instance a number; but the formula through which it is composed in the same way from the first couple and from the second couple of terms may be unknown and non analytical".

¹⁴⁷"One thing is to speak of quantities, another thing is to speak of formulas" ("Aliud est enim de quantitibus aliud de formulis loqui"), AVII3, 60, p. 759.

It seems to me that Leibniz stresses a distinction already noticed by Wallis and Huygens. Although it is not mentioned,¹⁴⁸ the case of the trisection problem comes immediately to the mind, as an exemplification of Leibniz's demarcation between 'formulas' and 'quantities': the impossibility of trisecting an angle boils down to the impossibility of finding a 'formula', namely a ruler-and-compass protocol, in order to solve the trisection for any angle. This result, on the contrary, does not claim the impossibility of trisecting any angle: in fact there are trisectable angles. Therefore, on the ground of this impossibility result only, we would not be able to decide, in principle, whether an angle α , having a certain measure, is trisectable or not.

Generalizing from this example, we can get to Leibniz's very conclusion: since there are non-analytical formulas or operations, which may yield analytical quantities as a result, when applied to analytical quantities, the impossibility of finding an analytic formula for the quadrature of any sector of a central conic, does not entail the non squarability of particular sectors, like the whole circle.

The manuscript AVII6, 28 provides sufficient evidence in order to conclude that Leibniz studied with particular care, in the year 1676, Gregory's arguments about the impossibility of squaring the central conic sections. I surmise that these studies might contribute to explicate the elliptic remarks to be found in Leibniz's letters to Oldenburg - dating from March 1675 - according to which Leibniz not only endorsed Huygens' criticism to Gregory, but also possessed 'new' objections (see: AIII1, 46, p. 204, quoted above). Leibniz's objections were certainly not new, if considered in the backdrop of Huygens' and Wallis' discussions, but we must take into account also the fact that Leibniz himself had not a full knowledge of the contributions of his predecessors, and therefore he could have been legitimately thinking that his own contribution was valuable, as it shed light on arguments merely sketched in Huygens' letters (in particular, the conceptual distinction between "formulas" and "quantities").

¹⁴⁸In order to exemplify the distinction just evoked between 'formulas' and 'quantities', Leibniz confines himself to (vague) numerical examples instead: he remarks in fact that given the numbers 3, 4, 6, 9 and 13 one might find a non-analytic or transcendental operation that, applied to numbers 4 and 6 can yield the number 3, and such that, applied to numbers 9 and 13, they yield the number 6. AVII3, 60, p. 759: "... Verbi gratia possibile est fortasse aliquam reperiri operationem, per quam eodem modo proveniat numerus 3 ex 4 et 6 quo ex 9 et 13, sed quis illam divinabit". (for instance it is perhaps possible to find an operation, through which the number 3 is computed, in the same way from 4 and 6, as the number 6 is composed from 9 and 13, but someone will find it). Compare the analogous example in AVII6, 28, p. 355.

Moreover, the arguments examined in this section explain why Leibniz was dissatisfied with Gregory's arguments, and why he finally opted for a new argument establishing that there is not a unique analytical formula which gives the quadrature of an arbitrary sector of the circle and the hyperbola.

8.7 An impossibility argument

8.7.1 Universal and particular quadratures

In order to understand precisely the significance of Leibniz's impossibility argument, let us turn to another discussion related to Gregory, in a note from 1676 (written between April and June 1676), and titled *Impossibilitas quadraturae circuli universalis*. In this tract, Leibniz introduced the following distinction:

*Quadratura duplex est, universalis et particularis: Universalis, quae regulam exhibet cujus ope quaelibet Circuli portio possit mensurari, seu cujus ope ex data tangente (vel sinu) possit inveniri arcus sive angulus. Particularis, quae certam circumferentiae portionem, (: et eas, quarum ad hanc portionem nota est ratio:) exhibet. Unde et si quis totum circulum totamve circumferentiam exhiberet, non vero nisi eas partes, quarum ad circumferentiam nota jam tum est ratio, is quadraturam, qualis desideratur, Universalem non dedisset.*¹⁴⁹

Leibniz's considerations, in the excerpt reproduced above, are confined to the quadrature of the circle. A distinction between two types of quadratures is introduced, which reminds of another distinction formulated by Huygens, in a letter from 12th November 1668, between 'definite' and 'indefinite' quadrature of the circle.¹⁵⁰ On one hand, Leibniz defines the 'universal quadrature' of the circle, namely the problem of finding a general formula, or a rule in order to determine an arbitrary sector of the circle or an arbitrary arc; and on the other he defines the problem of the 'particular quadrature' (also called "*specialis*" in another passage of the same text), namely the problem of finding the length of a given arc or the area of a sector, or the whole circle (the classical problem of the

¹⁴⁹AVII6, n. 18, p. 165: "There are two quadratures, universal and particular. The universal quadrature exhibits a rule, by whose aid any portion of the circle can be measured, or by whose aid, from a given tangent (or sine) the arc or the angle can be found. And then there is the particular quadrature, which exhibits a certain part of the circumference (and these, whose ratio with that part is known). Hence, if one exhibited the whole circle or the whole circumference, and nothing but these sectors, whose ratio with the circumference is already known, he would not give the desired universal quadrature".

¹⁵⁰*Cf.* this study, ch. 7, sec. 7.5.

quadrature of the circle, discussed in Archimedes' *Dimensio Circuli*, falls evidently under such category).

Leibniz had probably reached, upon the reading of the controversy between Gregory and of Huygens, and in the light of the criticism discussed in the previous section, a firm conviction that the problems of universal and particular quadratures ought to be distinguished as two conceptually different endeavors. One the motivations for this distinction was plausibly the criticism moved to Gregory, according to which the impossibility of finding an algebraic universal quadrature (namely an algebraic formula relating each sector with its inscribed and circumscribed polygons) does not necessarily entail the impossibility of the particular quadrature of the circle.

Leibniz was arguably influenced by his mentor Huygens, and maintained that the impossibility of the universal quadrature of the circle, even if correctly proved, did not have a bearing on the impossibility of the particular quadrature, namely on the problem of whether the circle might be analytical, or even commensurable with the square constructed on its diameter.¹⁵¹

This belief, which shines through the draft of the letter to Oldenburg from March 1675, was maintained also in the *De Quadratura Arithmetica*, where Leibniz gave, on one hand, an argument for the impossibility of the universal quadrature and, on the other, kept a cautious attitude towards the possibility of finding the sum of his series for $\frac{\pi}{4}$.

As the evidence in manuscripts shows, we can conclude that Leibniz had not yet discarded, by 1676, the possibility that the expression of the area of the circle through an infinite series could be effectively computed so as to obtain a rational or an irrational algebraic number. Leibniz must have conceived the problem of the 'particular' quadrature of the circle, by the end of his parisian stay, still as an open problem. Unfortunately, his mathematical work in the period 1676-1684 is still unknown for the most part,¹⁵² so that precise reconstructions of the evolution of Leibniz's ideas about the problem of the particular quadrature of the circle between 1674-76 and 1684 cannot be given here, and

¹⁵¹ Cf. in particular: AIII1, 46, p. 210. In AVII18 (p. 166-167), Leibniz affirmed: "Certas autem partes - Leibniz claimed in AVII6, 18- vel etiam totum Circulum (: sed non quamlibet ejus portionem:) analytice inveniri posse, nondum despero" ("I have not lost the hope yet that precise parts ("*certas autem partes*") or even the whole circle (but not any of its portion) can be found out analytically").

¹⁵² A survey of Leibniz's mathematical work during this period is given in Hess [1991].

requires further work on unpublished manuscripts.¹⁵³

8.7.2 The impossibility of the universal quadrature

The impossibility claim formulated in proposition LI of the *De Quadratura Arithmetica* refers to the universal quadrature of the central conic sections. Leibniz enunciated this impossibility result, with minor variations, in various texts from 1676 (Cf. AVII6, 18, p. 166, AVII6, 19, p. 176, AVII6, 28 p. 350ff, AVII6, 51, p. 675), among which I will consider the one belonging to the *De quadratura arithmetica*, namely proposition LI of AVII6, 51, since it presumably corresponded to Leibniz's ultimate viewpoint on this issue, before leaving Paris in September 1676.

Leibniz claimed the impossibility of the universal quadrature of the central conic sections by way of a peculiar grammatical construction, recurring to a couple of comparatives: it is impossible - Leibniz wrote - to find a better solution to the quadrature of the circle and the hyperbola, the ("*melio rem quadraturam*"), or a more geometrical relation ("*relationem quae magis geometrica sit*") than the one presented in the treatise (resumed, in this study, in equations 8.4.4 and 8.4.5).

But in which sense a solution of a quadrature problem might be better than another one? An answer can be sketched in the light of Leibniz's contemporary mathematical manuscripts examined in the previous sections, starting from the 1675 draft of a letter to Oldenburg, in which Leibniz had sketched a taxonomy of the various solutions offered to the circle-squaring problem, ordered from the least to the most exact one. An improved version of this classification was proposed again in a tract from Spring 1676, titled: *Praefatio opusculi de Quadratura Circuli Arithmetica* (AVII6, 19),¹⁵⁴ so that Leibniz had possibly this scheme in mind when he stated his impossibility result.

¹⁵³Sparse indications that Leibniz could believe the quadrature of the circle to be impossible, in all its occurrences, can be found too. Thus in the already evoked tract *Numeri Infiniti* (April 1676, in AVII1, 69), Leibniz inclined towards the belief about the impossibility of expressing the ratio between the area of the whole circle as an algebraic number, in agreement with an opinion he would reveal, several years later, in the published article *De vera proportione circuli*. We read in fact in the *De Vera proportione circuli*: "et licet uno numero summa ejus seriei [namely, of the infinite series for $\frac{\pi}{4}$] exprimi non possit, et series in infinitum producat. . ." (p. 120). A similar judgement can be found in a letter to Clüver from 1686 (A III, 4, N. 148, p. 286-287).

¹⁵⁴I recall that Leibniz did not mean to preface, by this tract, the *De Quadratura Arithmetica*, but another essay (that might be either the AVII6, 15, 20 or 28, all written before Summer 1676), which was nevertheless temporally and thematically close to the *De Quadratura* (Cf. Knobloch Knobloch [1989], p. 129-130).

Let us recall that in the classification of quadratures contained in the letter to Oldenburg, the ‘highest’ level was attained by the ‘geometrical quadrature’. This type of quadrature would be achieved if the problem of squaring the circle, or one of its sectors, could be solved by expressing the relation between an arc and its chord, or tangent (or between a sector and an inscribed or circumscribed polygon) by an equation of finite degree, and by constructing such an equation by means of curves admissible in cartesian geometry.¹⁵⁵ The geometrical quadrature of the circle was included by Leibniz, for instance in the *Praefatio* (AVII6, 19), among ‘perfect quadratures’.

By excluding, in the *De quadratura arithmetica*, the possibility of a ‘better’ quadrature of the circle or the hyperbola than the one obtained in his work, Leibniz was plausibly referring to the impossibility of obtaining a perfect quadrature of either of these curves.

In a similar way, a ‘more geometrical’ relation between an arc and its tangent would consist of a relation expressed through a finite polynomial equation (in this context, the term ‘geometrical’ employed by Leibniz follows Descartes’ terminology). Analogously, in virtue of the known relation between the surfaces of the hyperbolic sectors and their bases, a ‘better’ quadrature of the hyperbola would boil down to the finding of an algebraic relation between a logarithm and its number.

This elucidation leads us to the core of Leibniz’s impossibility argument expounded in *De Quadratura Arithmetica*. Strictly speaking, proposition LI of *De Quadratura Arithmetica* contains two distinct impossibility results, one concerning the circle, the other concerning the hyperbola, whose argumentative structures however mirror each other.¹⁵⁶

For the sake of simplicity, let us consider in more detail the case of the circle.¹⁵⁷ According to our previous discussion, theorem LI of *De Quadratura Arithmetica* can be thus paraphrased:

¹⁵⁵"Relationem arcus ad sinum, in universum certa aequatione determinati gradus exprimi" (AVII6, 19, p. 176: "to explicit the general relation of the arc with respect to the sine by an equation of finite dimension"). If such an equation could be found, the problem could also be solved by geometrical curves, in the cartesian sense: "Perfecta autem Quadratura quae lineis aequabilibus, ad certarum dimensionum aequationes revocabilibus, construatur" (AVII6, 19, p. 175: "The perfect quadrature, constructed by algebraic curves, reducible to equations in a finite degree").

¹⁵⁶I point out that one can consider the circle as a special case of the ellipse, so if there were a solution for the ellipse, there were also one for the circle, and in the other direction no solution for the circle implies no solution for the ellipse.

¹⁵⁷The theorem is also discussed in Knobloch [2006], p. 129.

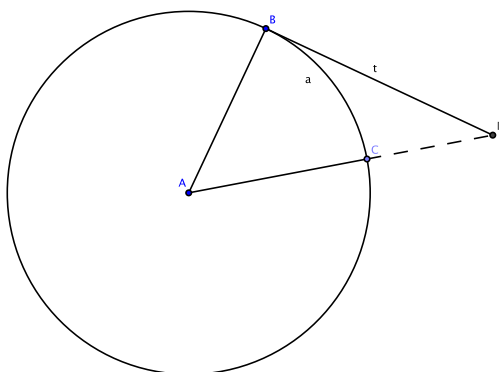

Figure 8.7.1: A circular arc and its tangent.

Given a circle with center A and radius AB ($= 1$), and an arbitrary arc $BC = \widehat{a}$ on its circumference (less than a quarter of the circumference itself), there is no algebraic relation between the arc and its corresponding tangent $BD = t$ (fig. 4.1).

Leibniz's proof proceeds by a *reductio* argument. Hence, Leibniz supposes that the relation ("relatio") between the arc \widehat{a} and its tangent t can be expressed by a cartesian equation in a fixed, finite degree n , independently from the chosen arc,¹⁵⁸ and advances the following hypothesis:

Sit t tangens, a arcus, radius 1 et aequatio relationem inter arcum et tangentem exprimens sit I. $ct + ma$ aequ. b . vel II. $ct + dt^2 + eta + n^2a + ma$ aequ. b . vel III. $ct + dt^2 + eta + ft^3 + gt^2a + hta^2 + pa^3 + na^2 + ma$ aequ. b . et ita porro.¹⁵⁹

¹⁵⁸AVII6, 51, p. 674: "Quaedam inter arcum et tangentem inventa esse magis geometrica quam nostra sit, id est quae finita quadam formula constet; utique illa relatio includi poterit in aequationem" ("Let us suppose, if it can be done, that a relation between an arc and its tangent has been found, more geometrical than our own, i.e. which consists of a finite formula, so that this relation can be included into an equation").

¹⁵⁹AVII6, 51, p. 674: "Let t be a tangent, a the arc, 1 the radius, and the equation expressing the

In other words, Leibniz assumes that the supposedly algebraic relation between an arc and its tangent can be expressed through "general formulas" ("*formulae generales*"), namely a polynomial equations of degree n in the unknowns a and t and in the undetermined coefficients c, m, b, d, \dots

Leibniz proposes three examples of such general formulas:

$$\begin{aligned} ct + ma &= b \\ ct + dt^2 + eta + n^2a + ma &= b \\ ct + dt^2 + eta + ft^3 + gt^2a + hta^2 + pa^3 + na^2 + ma &= b \\ &\vdots \end{aligned}$$

This list may be indefinitely extended by constructing higher and higher general algebraic equations in the same unknowns a and t .

Presumably, Leibniz relied on the cartesian technique of undetermined coefficients in order to express a polynomial equation of arbitrary degree in a sufficiently general form for the purpose of his proof.¹⁶⁰ Leibniz remarks in fact, few lines later:

Scilicet in quolibet gradu formula generalis exhibeatur, ad quam speciales semper poterunt reduci, literas b. c. d. e. f. etc. pro numeris aequationis specialis propositae sumendo, cum suis signis, aut aliquas harum literarum, quarum termini scilicet absunt, nihilo aequales ponendo.¹⁶¹

relation between an arc and its tangent be: I. $ct + ma = b$ or II. $ct + dt^2 + eta + n^2a + ma = b$ or III. $ct + dt^2 + eta + ft^3 + gt^2a + hta^2 + pa^3 + na^2 + ma = b$, and so on".

¹⁶⁰The method of undetermined coefficients is defined, according to the *Encyclopédie*, in these terms: "La méthode des coefficients indéterminés est une des plus importantes découvertes que l'on doive à Descartes. Cette méthode très en usage dans la théorie des équations, dans le calcul intégral, & en général dans un très - grand nombre de problèmes mathématiques, consiste à supposer l'inconnue égale à une quantité dans laquelle il entre des coefficients qu'on suppose connus, & qu'on désigne par des lettres; on substitue ensuite cette valeur de l'inconnue dans l'équation; & mettant les uns sous les autres les termes homogenes, on fait chaque coefficient= 0, & on détermine par ce moyen les coefficients indéterminés". The method presented and employed by Van Schooten can be found, for instance, in his commentary to Descartes' geometry (Descartes [1659-1661], p. 324), and it is applied in order to determine the solution of a cubic equation by the intersection of a circle and a parabola or, as seen in chapter 4 of this study, in order to reduce quartic equations. Leibniz himself applied this method, after 1676, in the analysis of quadrature problems, so that the use in *De quadratura arithmetica* might be one of the first instances of such a practice, as it is suggested by Parmentier in Leibniz [2004], p. 357. It is unclear, however, where Leibniz derived the formulas I, II, and III (in his text) from, and for which reason did he believe that they could represent general forms of quadratic equations, cubic equations, and so on.

¹⁶¹AVII6, 51, p. 674: "Indeed, a general formula in whatever degree may be exhibited, to which special

For instance, it can be shown that a particular equation ("*specialis formula*") like: $3t + 4t^2 - 6t^3 - t^2a + 5a = 10$ can be reduced to one of the equations above of corresponding degree (namely the third) simply by setting: $c = 3, d = 4, e = 0, f = -6, g = -1, h = 0, n = 0, p = 0, m = 5, b = 10$.

One may proceed in a similar way for any other special equations, by comparing homogeneous terms and setting the undetermined coefficients equal to particular numerical values.

In a second stage of the proof, Leibniz chooses one among the formulas given in the previous passage above, namely the third one:

$$ct + dt^2 + eta + ft^3 + gt^2a + hta^2 + pa^3 + na^2 + ma = b \quad (8.7.1)$$

and supposes that it expresses the general relation between an arc (less than a quadrant) and its corresponding tangent. This is an equation of third degree in the variables a and t , since the equation 8.7.1 generalizes all particular instances of cubic equations. Leibniz's choice of a cubic equation does not imply, at any rate, any loss of generality in the proof: one may choose another general equation in a fixed arbitrary degree n (for n natural number), and likewise assume that it expresses the relation between an arc and its tangent, without altering the structure of the argument.¹⁶²

Let us then consider, following Leibniz's reasoning, the problem of dividing a given arbitrary arc \widehat{a} into an arbitrary number of equal parts. Leibniz starts by discussing, without loss of generality, the case for $n = 11$. Solving the problem of the division of the arc \widehat{a} into 11 equal parts will boil down to construct the arc $\widehat{\theta} = \frac{a}{11}$, whose corresponding tangent will be, for example, t' (fig. 8.7.2).

Since the 8.7.1 has been assumed to express the relation between any given arc and its tangent, it will also express the relation between $\widehat{\theta}$ and t' . Hence Leibniz replaces, in

formulas may always be reduced, by taking the letters: b, c, d, e, f , or any of the other letters for the numerical coefficients (with their signs) of the special proposed equation, or by setting equal to zero the remaining letters, whose corresponding numerical coefficients are indeed lacking".

¹⁶²The point is stressed in Knobloch [2006], p. 128.

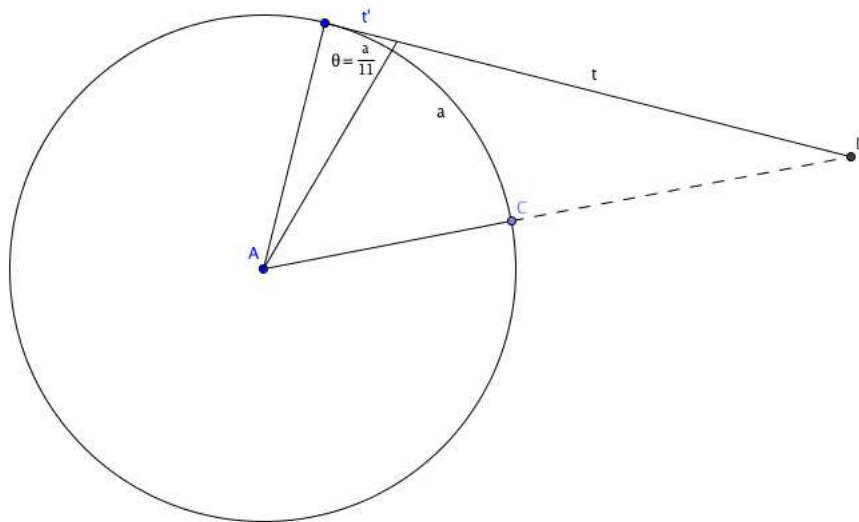

Figure 8.7.2: Division of the arc.

8.7.1, a by $\frac{a}{11}$ and t by t' , thus obtaining the following equation:

$$ct' + dt'^2 + et'(\frac{a}{11}) + ft'^3 + gt'^2(\frac{a}{11}) + ht(\frac{a}{11})^2 + p(\frac{a}{11})^3 + n(\frac{a}{11})^2 + m\frac{a}{11} = b$$

Assuming the arc \widehat{a} as given, the tangent t' (and consequently the corresponding arc $\widehat{\theta} = \frac{a}{11}$) can be found by constructing the above equation. Since t' occurs only up to the third power, Leibniz concludes that the problem of dividing an arc into 11 parts is a solid problem.

Leibniz crucially observes that any substitution of the form: $a \rightarrow \frac{a}{n}$ in the equation **8.7.1** leaves the degree of the equation unchanged: the problem of the n -section of an arc \widehat{a} can be always solved by a family of equations of third degree, or, more generally (let us remember that the restriction to degree 3 was arbitrarily chosen), by a family of equations of fixed, finite degree.

But this conclusion contradicts a well-known result on the theory of angular sections, given in a posthumous work by François Viète, *Ad angularium sectionum analyticen*

*theoremata Καθολικωτερα:*¹⁶³

Quod est absurdum, constat enim ex Vietae sectionibus angularibus pro anguli in partes sectione secundum numeros primos semper altiore atque altiore opus esse aequatione Anguli bisectionem esse problema planum, anguli trisectionem esse problema solidum sive cubicum, anguli quinquesectionem esse problema sursolidum, et ita porro in infinitum: absurdum est ergo generalem anguli sectionem esse problema cubicum. Eodem modo impossibile est generalem anguli sectionem esse problema ullius gradus determinati finiti; cum ut dixi aliud semper aliudque sit, pro alio atque alio partium in quas secundus est angulus, numero.¹⁶⁴

As precisely resumed by Leibniz, we can find in Viète's treatise the very reduction of the problem of the arc (or angle) division into 3, 5, and 7 parts to their corresponding algebraic equations. If we agree to call c the cord subtending the arc of a given angle φ inscribed in a circle with radius = 1, and to call x the cords subtending the arcs of the given angle φ , of its third, of its fifth, its seventh, and so on, the resulting equations can be derived (in modern notation):

$$c = x$$

For the division in "one part" (actually, no division occurs);

$$c = 3x - x^3$$

for the trisection of an arbitrary angle; then:

$$c = 5x - 5x^3 + x^5$$

¹⁶³The treatise was published only posthumously by A. Anderson in 1615. The text was known to Leibniz through Van Schooten's edition of Viète's *Opera* (1646). Several tracts written between 1674 and 1676 bear evidence to Leibniz's interest for the problem of the angular section: AVIII, 13, AVIII, 27 (April 1676), AVIII, 24 (May 1676), AVIII, 29 (May 1676), and AVII6, 27, (29 June 1676).

¹⁶⁴"... Which is absurd. It results in fact from the angular sections of Viète that we need an equation of ever higher degree for the section of the angle in equal parts according to prime numbers. The bisection is a plane problem, the trisection is a solid or cubic problem, the division of the angle in five parts is a sursolid problem, and so on, to the infinite. Hence it is absurd that the general section of the angle is a cubic problem. In the same way, it is impossible that the general section of the angle is a problem of any finite determined degree; as I said, it is always varying, according to the varying number of parts in which the angle must be divided" (VII6, n. 51, p. 675).

for the division into five equal parts; and:

$$c = 7x - 14x^3 + 7x^5 - x^7$$

for the division into seven equal parts.¹⁶⁵

Viète did not confine himself to finding the equations corresponding to these problems, but tabulated in a schema the coefficients of the equations corresponding to successive (odd and even) divisions of an arc of an arbitrary angle φ , up to 21 parts. His schema of coefficients (*Canon*) is constructed according to a recursive rule, which enables one to extrapolate the equations corresponding to the division of the angle into any number n of parts (where n is an integer). In this way Viète claimed to have given the analytical translation of the more general problem of finding: "one angle to another as one number is to another", namely the general section of the angle, a problem already discussed in Pappus' *Collection*.¹⁶⁶

As an interesting consequence of the analytic treatment of the problem of the n -th section of an angle, Leibniz remarked a correspondence between the number of angular divisions and the degree of the corresponding equation: namely, for every n , the n -th-section of an arbitrary angle is associated to an equation of n -th degree.¹⁶⁷

On the top of this, he conjectured that "we need an equation of ever higher degree for the section of the angle in equal parts according to prime numbers". This statement

¹⁶⁵Viète [1983], p. 301-303. See also Bos [2001], p. 215. In the treatise, Viète derives several equations corresponding to the same instances of the problem according to different choices of the unknown, namely, several equations corresponding to the trisection problem, several equations corresponding to the division into five parts, and so on. Nevertheless, all equations corresponding to a division of the angle into, say, n parts, have degree n : for the sake of our argument, the above choice is then sufficient.

¹⁶⁶Viète [1983], p. 443; Viète [1646], p. 300. I note that the problem is not solved by giving a single solution for any n (where n is the number of division), but by giving a method in order to determine, for any given n , the corresponding equation (which changes according to the number of divisions). In this way, Viète could survey a problem admitting an infinite instance of cases. In the same way, he derived other tables for coefficients, corresponding to equations resulting from different choices of the unknowns.

¹⁶⁷Leibniz could have derived this result as an immediate corollary from his study of Viète's tables Viète [1983], p. 434; Viète [1646], p. 295, for instance), although it is never explicitly remarked by Viète, to my knowledge.

involves the impossibility of reducing the problem of the general angular division to one polynomial equation of finite degree, a result which contradicts Leibniz's initial assumption, that the relation between an arc and its tangent, and therefore the angular division problem, could be expressed by a cartesian equation in a finite fixed degree.

In the light of this conclusion, Leibniz denies that the relation between an arbitrary arc of the circle and its corresponding arc could be reduced to an algebraic equation, and concludes that a "more geometrical" solution to this problem than the one obtained in the *De Quadratura Arithmetica* - which relied on an infinite formula, as we have seen - cannot be found.

8.7.3 The impossibility of finding a general quadrature of the hyperbola

An analogous *reductio* proof holds for the the hyperbola, Leibniz argued in the final section of proposition LI:

... nam, quemadmodum generali relatione inter arcum et latera inventa posset haberi sectio anguli universalis, per unam aequationem certi gradus; ita generali inventa quadratura hyperbolae sive relatione inter numerum et logarithmum, possent inveniri quocunque mediae proportionales ope unius aequationis certi gradus, quod etiam absurdum esse, analyticis constat (...)
 Impossibilis est ergo quadratura generalis sive constructio serviens pro data qualibet parte Hyperbolae aut Circuli adeoque et Ellipseos, quae magis geometrica sit, quam nostra est.¹⁶⁸

As for the case of the circle, Leibniz excluded that the quadrature of an arbitrary sector of hyperbola could be expressed by a finite algebraic equation. He grounded his argument on the fact that the hyperbola-area offers a geometrical model in order to interpret the concept of logarithm. Hence, the possibility of an algebraic quadrature of any sector of

¹⁶⁸AVII6, n. 51, p. 674. "Indeed, just like a general relation between arcs and cords will offer a general section of the angle through one equation of determinate degree, so finding a general quadrature of the hyperbola, namely a relation between a number and its logarithm, would allow us to find as many mean proportions through one equation of determinate degree; which is absurd, as mathematicians know (...) hence it is impossible to find a general quadrature, or a construction applying to any given sector of the hyperbola, or of the circle and the ellipse, which is more geometrical than our own". See also Knobloch [2006], p. 129.

the hyperbola would involve the possibility of expressing the relation between a number and its logarithm by a finite algebraic equation too, which is absurd.

In order to understand Leibniz's argument, let us remark that the problem of finding n mean proportionals between two segments a and b ($a < b$), or equivalently, the problem of dividing the ratio $\frac{a}{b}$ into $n + 1$ terms¹⁶⁹ is the problem of finding a sequence of segments: $x_1, x_2, x_3 \dots x_n$ such that the ratio of any two consecutive segments in the sequence: $a, x_1, x_2, x_3 \dots x_n, b$ is constant. Since the terms of this sequence have a constant ratio, they will form a geometric progression. By setting $a = 1$ for simplicity, the progression can be also represented in these terms: $x_1^0 = 1, x_1^1, x_1^2, x_1^3 \dots x_1^n, x_1^{n+1} = b$.

A pairing can be built between the geometric progression: $x_1^0, x_1^1, x_1^2, x_1^3 \dots$ and an arithmetic progression formed by the exponents of the previous progression: $0, 1, 2, 3 \dots$. In this way the product of two terms in the geometric progression (for instance: $x_1^l \cdot x_1^k$) is equal to a term (namely: x_1^m) whose exponent is equal to the sum of the corresponding terms on the arithmetic progression (namely: $m = l+k$). If we indicate by the symbol: ' f ' such a pairing between the geometric progression of the x_1^i and the arithmetic progression of their exponents i , the following equality is satisfied: $f(x_1^l \cdot x_1^k) = f(x_1^l) + f(x_1^k) = x_1^{l+k}$.

If the relation between a number and its logarithm, denoted above by the symbol ' f ', were algebraic, then the problem of inserting an arbitrary number of mean proportionals between segment 1 and segment b (which amounts to the construction of a term in the progression of numbers, whose corresponding logarithm is known) could be expressed by an algebraic equations in a fixed finite degree, namely: $m+1 = f(b)$, for any number m of desired mean proportionals. However it is known from Book III of Descartes' *Géométrie*

¹⁶⁹The expression 'division of a ratio' ("*sectio rationis*") is thus explained by Leibniz: "Sectionem autem rationis sive Logarithmi idem esse constat, quod inventionem mediarum proportionalium, est enim trisectio rationis, idem quod inventio duarum mediarum, et sectio rationis in quinque partes aequales est inventio mediarum quatuor. Et bisectio rationis est inventio unius mediae, seu extractio radicis quadraticae quemadmodum contra duplicata ratio est ratio quadratorum, et triplicata cuborum, ex veterum loquendi more, qui plane cum hodiernis per Logarithmos operationibus consentit, duplicatio enim logarithmi quadratum dabit, et triplicatio cubum, et compositio rationum fiet additione Logarithmorum" (AVII6, 51, p. 555-556): "It is clear that the section of the ratio or of the logarithm amounts to the same as the finding of mean proportionals. Indeed, the trisection of the ratio it is the same as the finding of two means, and the section of the ratio in five equal parts coincides with the finding of four means. And the bisection of the ratio is the finding of one mean, or the extraction of a square root, in the same way in which, conversely, the doubling of the ratio is the ratio of the squares, and the tripling is the ratio of cubes, according to the language of the ancients, which plainly corresponds with the modern operations with logarithms. In fact the duplication of a logarithm will yield a square, and the triplication a cube, and the composition of ratios will be obtain by the addition of logarithms".

that the problem of inserting an arbitrary number n of mean proportionals between two given segments a and b can be expressed by an equation in the form: $(x_1)^n = ab^{n+1}$, with n ever increasing according to the number of inserted means.

Probably relying on Descartes' considerations contained in *La Géométrie*, Leibniz discussed the nature of the relation between the logarithms and their numbers along similar lines to the case of the relation between an arc and its tangent. He could thus state that the degree of the equations associated to every instance of the problem of inserting a prime number m of mean proportionals increases according to m so that, contrary to our presuppositions, the general problem of inserting m mean proportionals between given segments cannot be expressed, for any m , through an algebraic equation of fixed degree.¹⁷⁰ Such considerations will lead to the following conclusion, which closes the *De Quadratura Arithmetica*:

Impossibilis est ergo quadratura generalis sive constructio serviens pro data qualibet parte Hyperbolae aut Circuli adeoque et Ellipseos, quas magis geometrica sit, quam nostra est. Q. E. D.¹⁷¹

8.8 Underdeveloped parts in Leibniz's impossibility argument

Leibniz's proof of theorem LI is flawed, or at most incomplete, although the missing arguments were not generally recognized by his contemporary readers. I will confine myself to the case of the circle, since the same structural weakness holds for the 'dual' case of the hyperbola. A major missing point of his proof concerns the reducibility of the equations associated to the angular sections. In fact, even if Leibniz could associate, on the basis of Viète's *Angular Sections*, any instance of the angular section problem to a finite polynomial equation, he did not supplement a method to check whether the connected equation could be factored, and therefore lowered in degree. This remains a dependable point to be clarified, since the possibility of associating equations of higher and higher degree to corresponding higher and higher angular divisions depends on the absence of this phenomenon, otherwise this correspondence might collapse, as well as the whole proof of proposition LI.

¹⁷⁰AVII6, 51, p. p. 556.

¹⁷¹AVII6, 51, p. 676: "It is thus impossible a general quadrature, namely a construction fit for any given part of the hyperbola, the circle and the Ellipse, which is more geometrical than our own".

In the context of Viète's treatise, the problem is not raised. This is not surprising though, if we consider the historical context: indeed, up to Descartes' *Géométrie* (1637), the relation between the geometrical constructibility of a problem and the degree of the corresponding equation was not fully understood.¹⁷²

Of course, it was well known that the problem of dividing an angle into $4, 8 \dots$ and generally into 2^n parts could be conceived as the result of successive bisections and it was therefore a plane problem, despite it could be associated to an equation of higher degree than two, as it was well known that the problem of constructing an heptagon was a solid one, although it could yield an equation higher than a cubic. Similar considerations occurred for the division of an angle into a number m of sections, where m could be decomposed into prime factors. Nevertheless, either these cases were not studied systematically, or mathematicians solved them geometrically, through the reduction of a geometric problem into easier problems, rather than through the algebraic study of the reducibility of the correlated equations.¹⁷³

Leibniz was certainly aware of these cases, since in the proof of theorem *LI* he considered only angle divisions into a prime number of parts, and, in this way, he countenanced the eventuality that a certain problem could be reduced to easier instances.¹⁷⁴

However, he never addressed, in the *De Quadratura Arithmetica*, a concern about the possible factorization of the associated equations. We can suppose either that he ignored this problematics, or that he did not judge it relevant for the problem of the angular division. The first eventuality must be excluded, as there are manuscripts proving that Leibniz studied the problem of lowering the degree of an equation, before 1676, even

¹⁷²See also Bos [2001], p. 214, and p. 393-397.

¹⁷³As Viète himself showed in his *Ad problema quod omnibus mathematicis totius orbis construendum proposuit Adrianus Romanus Responsum* (1595), reproduced in in Viète [1646], p. 305, the problem of dividing an angle into 45 parts was indeed reducible to the successive solution of a quinquisection and two successive trisections. Another example treating the subject of angular divisions, with a particular emphasis on the reduction of problems, was a tract written by van Schooten, which Leibniz might have consulted during his parisian years: *Aequationes ad dividendum angulum seu arcum, in partes aequales, numero impari*. The tract is contained in the work *Exercitationum mathematicarum libri quinque*, published in 1656 (see van Schooten [1656-57], book V).

¹⁷⁴We stress, on this concern, a slight but significant difference between the argument offered in AVII6, 51, *LI* and the argument offered in the alleged preface to this text, namely, AVII6, 19. In this text, Leibniz does not refer to the division of the angle into a prime number of parts, but only to the division into an odd number of parts: "constat enim tot esse varios gradus problematum, quot sunt numeri (saltem impares) sectionum". Maybe Leibniz had overlooked the detail that sections must be not only an odd, but also a prime number.

without reaching a conclusion.¹⁷⁵

I therefore turn to the second eventuality. In *La Géométrie*, Descartes stressed as a requisite of the analysis of a problem that the chosen end-equation must be of the lowest possible degree. This requirement was dictated by his method of construction of geometric problem, since the degree of an equation associated to a problem indicated its class, and therefore gave also indication on the curves one must employ for its construction.

With such an aim in mind, Descartes presented in book III of *La Géométrie* several rules in order to manipulate polynomial equations and eventually check whether it could be transformed into an equation of lower degree. The algebraic transformations which changed the degree of an equation $P(x) = 0$ were basically of two kinds. The first one concerned the factorization of the polynomial $P(x)$, namely the possibility of rewriting it as the product two other polynomials $Q(x)$ and $R(x)$, so that the equation could be also rewritten as: $P(x) = Q(x)R(x) = 0$. In this case, the coefficients of Q and R could be constructed by plane means (ruler and compass) from the coefficients of P . If such a reduction was possible, and both $Q(x)$ and $R(x)$ were not reducible any further, then the equation $P(x) = 0$ could be solved either by solving $Q(x) = 0$ or $R(x) = 0$, where polynomials $Q(x)$ and $R(x)$ had lower degree than the $P(x)$. The second kind of transformation, known by Descartes too, occurred when the equation $P(x) = 0$ could be rewritten as $Q(R(x)) = 0$. In this case, the reduction obtains through two steps: at first, the equation $Q(y) = 0$ is constructed, and then the equation $y = R(x)$ too.

The rule studied by Descartes in book three of *La Géométrie* applied in particular to the first kind of reducibility. However, despite the importance of reducibility for the adequate construction of a problem was well remarked by Descartes, this concept remained somewhat "fluid" in the context of cartesian geometry, probably also because the required notions for its rigorous definition in the modern sense were either lacking or stated ambiguously. Moreover, when applied to the problem of the angular division, the question of reducibility was not merely grounded on a fluid concept, but became extremely convoluted, since it required a survey of an infinity of cases.

¹⁷⁵ Cf. AVIII, 109, titled: *Aequationum depressiones*, p. 667: "Toutes ces méthodes [different methods for decomposing equations, that Leibniz had illustrated in the previous lines] ne sont point assurées. Et je ne voys point de moyen encore de demonstrier geometriquement ou analytiquement qu'une equation donnee est indeprimable". Moreover, the second volume of Leibniz's mathematical writings contains numerous manuscripts, written between 1675 and 1676, dedicated to the topic of reducibility of equations (I refer, in particular, to: AVII2, 3, 51, 20).

Nevertheless, even if Leibniz was unable to solve the problem of reducibility, or to give it a clear formulation, it seems that he could have mentioned it as a possible difficulty. The only hints to be found in the available documents seem to indicate that Leibniz considered the analytical treatment of angular sections as a well known fact to mathematicians, which therefore did not need to be surveyed in detail:

et notum est analyticis, pro anguli in partes sectione secundum numeros primos semper altiore magis magisque opus esse aequatione ut Anguli bisectionem esse problema planum, anguli trisectionem esse problema solidum sive cubicum, anguli quinquesectionem esse problema sursolidum; et ita porro in infinitum (...) Hanc propositionem ejusque demonstrationem analyticis claram esse confido. Aliis ne scripta quidem esto. Nam si in lineis exhibenda esset ejus demonstratio ingenti apparatu opus foret.¹⁷⁶

Leibniz's impossibility argument was probably known by the end of XVIIth century, since it circulated in an unpublished and later in a published form, although considerably shortened with respect to the version found in the *De quadratura arithmetica*.¹⁷⁷ However, his readers did not raise any objections, probably agreeing with Leibniz's opinion that the correspondence between equations in ever higher degree and ever higher number of angular sections was a well-known fact to mathematicians. Hence, we can conclude on the basis of the previous remarks that Leibniz's omission is not surprising in the backdrop of mathematical context of his time, and probably was not perceived as such by other practitioners.¹⁷⁸

This opinion seemed to persist up to the middle of XVIIIth century. For instance, in his book *Histoire des recherches sur la Quadrature du cercle* (1758), J.E. Montucla presented

¹⁷⁶AVII6, 28, p. 350: "It is known to the analysts, that one needs higher and higher degree equations in order to divide the angle in equal parts, according to the prime numbers, so that the bisection of the angle is a plane problem, the trisection is a solid or cubic one, the quinquesection is a supra-solid problem, and so on *in infinitum* (...) I trust that this proposition and its proof is clear to the analysts. I will not write anything else. Indeed, if one must exhibit it with curves, its proof would require a vast apparatus."

¹⁷⁷See for instance: Leibniz [1686], also in LSG, 5, pp. 226-233; for a french modern translation, in particular: Leibniz [1989], p. 134.

¹⁷⁸See LSG5, p. 226-233, and also Leibniz [1989], p. 126-143. When the problem of the angular division was touched by other authors, however, considerations on reducibility do not seem to have been raised either. Thus, in his *Traité Analytique sur les Sections Coniques* (1707), L'Hôpital introduced the problem of the angle divisions within a discussion about the construction of regular polygons, and explicitly remarked that the equations derived by Viète for each instance of the general angular division problem were: "les plus simples qu'il est possible, lorsque le nombre des parties égales est un nombre premier" (*Traité*, p. 418).

an argument analogous to the one given by Leibniz (without mentioning him, though) in a discussion on the unsolvability of the circle squaring problem.

After having introduced the distinction between the indefinite and the definite quadrature of the circle (which follows the same lines as Huygens' and Leibniz's distinctions), and having discussed several arguments for the impossibility of the universal quadrature of the circle, which although not fully satisfying, might add to the impossibility of the indefinite (or universal) quadrature of the circle "une probabilité qui approche beaucoup de la certitude", Montucla proposes his own argument, which turns out to be equivalent to the one read in theorem LI of the *De Quadratura Arithmetica*.

In fact, at the core of Montucla's reasoning we find the following claim: if the relation between an arc and its tangent were expressed by a finite polynomial equation, we would obtain a contradiction with the analytical treatment of the problem of the angle division. Concerning this latter problem, the conclusion reached by Montucla agrees with the one reached by Leibniz:

Quel que soit le nombre n , il ne peut donc être fini et déterminé, puisqu'il doit répondre à tous les cas imaginables des sections angulaires, et qu'il y en a une infinité qui conduisent à des équations d'un degré infini.¹⁷⁹

As a concluding remark, we observe that the second edition of the *Histoire* contains an interesting *addendum* to this argument made by the editor S. F. Lacroix. Lacroix confines himself to observe that Montucla's reasoning cannot be taken as a proof yet. Since this note was added for the second edition of 1831, it might be taken to show that by this time Montucla's, and *a fortiori* Leibniz's arguments were viewed as problematical. Unfortunately, the editor does not specify why these impossibility proofs are incorrect, but in the light of our previous remarks, it does not seem too far fetched to conjecture that he might point to the problem of the reducibility of equations, which would soon acquire a different meaning thanks to Galois theory.¹⁸⁰

¹⁷⁹Montucla [1831], p. 107-110.

¹⁸⁰Whereas early modern geometers tried to establish the proper level of each instance of the general angular section problem with respect to the cartesian classification of problem into classes, the modern approach to the problem of angular division considers rather the construction of regular polygons, understood as a particular case of the general angle division. One of the most significant results obtained on this concern was made by Gauss few years earlier than the second edition of Montucla's book, in 1801: Gauss proved that the construction of all regular n -gons for n of the form $2^\alpha p_1 p_2 \dots p_n$, where the p_i 's are different Fermat primes, namely, primes of the form $2^{2^k} + 1$ ($\alpha, k \in \mathbb{N}$), and claimed, without giving the proof, that one cannot construct any other regular n -gon with any number of sides (Lützen

8.9 The transcendental nature of curves

It is now evident, in the light of the previous arguments, that Leibniz's impossibility proof advanced in the last proposition of the *De Quadratura Arithmetica*, concerns the "universal" quadrature of the circle and the hyperbola. With hindsight, we may say that Leibniz's result concerns the impossibility of expressing the tangent-function (or its inverse) and the logarithmic (or exponential) function in terms of a finite composition of algebraic operations. As I have already observed with respect to Gregory's impossibility theorem, a knowledge of the transcendental nature of some functions might be obtained in a more straightforward way than through the complex arguments deployed by Leibniz, and by Gregory, simply by proving the periodicity of the curves which describe these functions.

An insight into this property could have been reached by early modern geometers, for instance by showing that certain curves intersect a given straight line in infinitely many points. This argument can hold for several transcendental curves and relations, like trigonometric ones, which are involved in the indefinite quadrature of the circle, although it does not hold, at first sight, for the logarithmic or exponential: this might have been one of the reasons why this graphical argument was considered as lacking sufficient generality.¹⁸¹

It was probably evident to Leibniz that the correspondence established between the operations of multiplication and addition, or between a geometric and an arithmetic progression, which stand at the root of the concept of logarithms, could not be interpreted, in the framework of XVI and XVII century geometric algebra, without violating homogeneity. A similar phenomenon occurred in the case of trigonometric relations, which had

[2009], p. 387). Gauss' result corresponds to the if-part of the following "classical" theorem nowadays: "A regular n -sided polygon is constructible by straight-edge and compass alone if and only if n is of the form $2^\alpha p_1 p_2 \dots p_n$ for an integer α and distinct primes p_i of the form $2^{2^k} + 1$ " (see for instance its proof in Hartshorne [2000], p. 258), whose proof can be found for the first time in Wantzel. This result is crucial in order to solve the following problem, also related to the general angle division, and to our previous discussion: for which natural numbers $n > 2$, does it exist a geometric construction in a finite number of steps to divide an arbitrary angle into n equal parts, using straightedge and compasses alone? In this perspective, it becomes relevant to characterize the set of such numbers n , which we can call T . On the ground of Gauss' result, and on the elementary facts that (1) if $n \in T$ and $k|n$, then $k \in T$ and (2) if $n \in T$, then $n^2 \in T$, one can prove that the set T contains only the powers of 2. In other words, an arbitrary angle can be divided into n parts by ruler and compass if and only if $n = 2^k$ (with $k \in \mathbb{N}$). A proof of this result is given, for instance, in Buckley and Machale [1985].

¹⁸¹As we know, the exponential function is a periodic function too (in fact, it is periodic with imaginary period: $2\pi i$, and can be written as: $e^{ai+b} = e^a(\cos b + i \sin b)$) but this could not have been guessed by the methods available to early-modern geometers.

appeared in the form of numerical tables, and they could not be translated in the language of geometry, unless one accepted the homogeneity between circular and rectilinear magnitudes.¹⁸²

Trigonometric and logarithmic relations could be expressed, in XVI and XVIIth century by tabulating their numerical instances or, graphically, by generating curves through pointwise constructions. It was for instance common in XVIIth century to represent the logarithmic correspondence between an arithmetic progression and a geometric progression in a graphical form, namely as a curve constructed in a pointwise way.¹⁸³

Leibniz reproduced these discoveries on the logarithmic curve and discussed them in several manuscripts from his parisian period. Also in *De Quadratura Arithmetica* there are discussions about the pointwise construction of this curve.¹⁸⁴ The known constructions which engendered the logarithmic or exponential curve were ‘specific’ pointwise constructions (see this study, ch. 5 sec. 5.3) since they were obtained by interpolating the points individuated through the pairing of the respective terms of a geometric and an arithmetic progression could be constructed geometrically (namely by algebraic curves). It is certainly possible to construct as many points on the logarithmic curve as one wishes: it is sufficient to insert a higher number of mean proportionals between two given segments: this can be done, as we know, using algebraic curves, and by forming a dense net of points belonging to the curve. However it is not possible, with the sole tools of cartesian geometry, to exhibit any arbitrary point on the logarithmic or exponential curve. On this ground, and on the ground of the lack of known methods for producing the logarithmic through a linkage, Leibniz called, especially in his studies from 1673-1674, the logarithmic curve ‘mechanical’, thus endorsing a cartesian standpoint.¹⁸⁵

¹⁸²See Giusti, in Belgioioso and Costabel [1990], p. 429.

¹⁸³I have already discussed in this dissertation the case of the logarithmic (or exponential) curve, described as early as 1619 in the *Cogitationes Privatae* by Descartes (the curve was known by Descartes as ‘linea proportionum’). Leibniz did studied the *Cogitationes* in 1676, but he could certainly have learned about this curve from many other sources. For instance, the logarithmic curve is thus described by G. Pardies, one of Leibniz’s sources on this subject (cf. AVII3, 38₁₂, p. 484), by graphically representing the correspondence between two sequences: " ... Soit la ligne droite *AE* divisée par parties égales *AB, BC, CD, DE*, etc. Par les points *A, B, C* soient imaginées les lignes droites *Aa, Bb, Cc* parallèles entre elles, qui soient en progression géométrique (...) nous aurons deux progressions de lignes, l’une arithmetique, l’autre geometrique ..." (Pardies [1671], p. 89).

¹⁸⁴Cf. proposition XLIII (AVII6, 51, p. 618).

¹⁸⁵Cf. for instance the following words sent by Leibniz to Oldenburg: "Pardies dabit dissertationem de linea logarithmica ejusque usu in solvendis problematis graduum omnis generis: eam lineam attigit in suis Elementis geometriae. Sed ea linea describi non nisi per puncta, ni fallor, potest, id est geometrica non est..." (Leibniz to Oldenburg, March 1673, AIII1, 9. p. 43: Pardies will give a disseration on the logarithmic curve and its use in solving problems of any kind of degree. He explicates this curve in his

However his position changed in the course of the two successive years. In the already quoted *Praefatio* from Spring 1676, Leibniz introduced a second curve analogous to the logarithmic, while discussing an argument for impossibility of expressing the relation between an arc and its sine through an equation of fixed, finite dimension. This argument, although related to the one presented in the closing proposition of the *De Quadratura Arithmetica*, relies on a slightly different reasoning. We read in fact in Leibniz's words:

Sed relationem arcus ad sinum in universum aequatione certae dimensionis explicari impossibile est. Quod facile sic demonstratur. Esto aequatio illa inventa, gradus cujuscunque certi, verbi gratia, cubica, quadrato-quadratica, surdesolida seu gradus quinti, gradus sexti, et ita porro, ita scilicet ut maxima aliqua sit aequationis inventae dimensio, exponentem habens numerum finitum. Hoc posito linea curva ejusdem gradus delineari poterit, ita ut abscissa exprimente sinus, ordinata exprimat arcus, vel contra. Hujus ergo lineae ope poterit arcus, vel angulus in data ratione secari, sive arcus, qui ad datum rationem habeat datam, inveniri sinus; ergo problema sectionis anguli universalis certi erit gradus, solidum scilicet, aut sursolidum, aut alterius gradus altioris, quem scilicet natura vel aequatio hujus lineae. dictae ostendet. Sed hoc absurdum est; constat enim tot esse varios gradus problematum, quot sunt numeri (saltem impares) sectionum; nam bisectio anguli est problema planum, trisectio problema solidum sive Conicum, quinquesectio est problema surdesolidum, et ita porro in infinitum, altius fit problema prout major est numerus partium aequalium, in quas dividendus est angulus; quod apud Analyticos in confesso est, et facile probari posset universaliter, si locus pateretur. Impossibile est ergo relationem arcus ad sinum, in universum certa aequatione determinati gradus exprimi.¹⁸⁶

Elements of geometry. But that line can be described only by points, if I am not wrong, that is it is not geometrical"). By observing that the logarithmic could be described: "per puncta", Leibniz arguably referred to the procedure of pointwise description of the quadratrix, for instance (see ch. 5, sec. 5.2.3) which cannot be supplemented by a continuous construction by linkages.

¹⁸⁶AVII6, p. 176. "But it is impossible to unravel the relation of the arc to the sine, universally, through an equation of a certain dimension. This is easily proved in this way. Let an equation of a certain degree whatsoever be invented; for instance, a cubic, a quadrato-quadratic, a supersolid or an equation of fifth degree, or of sixth, and so on, in such a way that the invented equation is in a certain highest degree, since it has a finite number as exponent. Once this is conceded, a curve of the same degree can be described, so that while the abscissa expresses the sines, its ordinate will express the arcs, or viceversa. Thus, by means of this line, the angle or the arc can be divided in a given ratio, or the sine having a given ratio to the given arc can be found. Thus, the problem of the universal section of the angle will be of finite degree, either solid, or supersolid, or of another higher degree, which the nature or the equation of this curve will show. But this is absurd: it is well known indeed that there are as many degrees of problems as many are the numbers of the odd sections, at least. Indeed, the bisection

This passage might be considered a primitive version of the impossibility argument expounded in proposition LI, and analyzed before in this chapter. Leibniz describes here the curve, later called "*figura sinuum*" or "*linea sinuum*",¹⁸⁷ whose abscissas (understood as the segment-distances from each point lying on the curve to a couple of straight lines intersecting at right angles, as it is currently assumed in *De Quadratura Arithmetica*) express the sines of the arcs described in a circle with given radius, and whose ordinates express the corresponding arc-lengths (i.e. the measure of the length of the arcs in the domain of segments). Although Leibniz remains silent about the method for constructing this curve, the *figura* or *linea sinuum* can be traced pointwise by plotting an arbitrary number of points whose abscissas correspond to successive sines in a given quarter of circle, for instance, and whose ordinates express the corresponding arc-lengths.

The curve so imagined is a sectrix curve by definition, since it will allow us to construct the n -th part of any arc by exhibiting its corresponding sine. On this ground, Leibniz presents, in the passage from the *Praefatio* reproduced above, an argument analogous to the one we read in proposition LI, in order to exclude that the *linea sinuum* can be associated to a finite degree polynomial equation, and therefore in order to exclude this curve from geometrical curves, in the cartesian sense. Reasoning by *absurdum*, Leibniz associates to the curve a finite algebraic equation with a fixed degree, and derives immediately a contradiction, since the curve of the sines can solve the problem of the general section of the angle and thus construct algebraic equations of ever-higher degree (each corresponding to a division into a prime number of sections). Since the *linea sinuum* has been constructed following the rule of associating to each arc its corresponding sine, one shall conclude that this very rule is not grounded on any algebraic relation, so that the curve at stake is not a geometrical one, in the cartesian sense. From this, Leibniz could also conclude: "it is impossible to express the relation between arc and sine universally, with a single equation of determinate degree".

of the angle is a plane problem, the trisection a solid or conic problem, the quinquisection a supersolid problem, and so on infinitely. The problem becomes of higher degree accordingly, as the number of equal parts in which the angle must be divided increases. That it is admitted by Analytics, and it could be proved universally, if we had space. Thus, it is impossible to express the relation between arc and sine universally, with a single equation of determinate degree."

¹⁸⁷ Cf. for instance in a letter to Huygens from 1694: "Voicy un Exemple aisé pour les differences secondes pro linea sinuum, c'est-à-dire lors que les arcs de cercle étendus en ligne droite estant les ordonnées, les sinus sont les abscisses", Huygens [1888-1950], vol. 10, p. 677. G. Loria (Loria [1930]p. 179) identifies this curve with a sinusoid, but since in the setting of *XVIIth* century geometry one coordinate was not preferred to another, the curve might be identified with the graph of the arcsin function.

Leibniz decided to replace this argument with the one presented in theorem LI of the *De Quadratura Arithmetica*, probably because the reference to the ‘curve of the sines’ is not necessary for the proof to reach its goal, and can be therefore eliminated from its structure.

However, Leibniz did not completely dismiss the *figura* or *linea sinuum* in *De Quadratura Arithmetica*, since he evoked in the course of the treatise (but not in the last proposition, where an impossibility proof is at stake), and pointed out its similarities with the logarithmic curve with respect to their mode of construction, and to their expressability through non-algebraic, i.e. transcendental equations.¹⁸⁸

In fact, both the logarithmic and the curve of the sines should be considered mechanical, according to the cartesian demarcation. In the period between 1673 and 1675, Leibniz gradually substituted the word ‘mechanical’ with the new word ‘transcendental’, in order to denote those curves which, contrarily to ‘algebraic’ ones, could not be associated to polynomial equations.¹⁸⁹

The terms ‘algebraic’ and ‘transcendental’ were introduced, with respect to curves as part of a broad attempt, conducted by Leibniz, to reconceptualize the ontology of geometry as it was framed by Descartes in his geometry: I remark that the dichotomy algebraic/transcendental was not a simple renaming of the cartesian demarcation between geometrical and mechanical curves, since Leibniz’s research was accompanied and subtended by an intense critique of the cartesian construal of geometricity.¹⁹⁰

As a result of this critique, Leibniz modified the cartesian canon of exactness for curves and for constructions (we have already seen, in section 8.5.2, how Leibniz had defined quadratures obtained by mechanical curves as “exact”). It can be ventured the hypothesis that Leibniz admitted, by the end of his stay in Paris, the possibility that a curve might be exact, and therefore geometrical, provided it could be described according to a precise rule (“*describendi ratione*”), even if this rule could not be expressed by an algebraic equation, but by a transcendental one.¹⁹¹ By referring to a *ratio describendi*,

¹⁸⁸Cf. for instance: AVII6, 51, p. 636.

¹⁸⁹See this chapter, sec. 8.5.2 for a study of the notion of ‘transcendental’ with respect to the quadrature of the circle. One can also compare a tract from autumn 1673, in which the logarithmic is explicitly ranked as a ‘transcendental’ curve (AVII3, 23, p. 265-266).

¹⁹⁰Cf. Knobloch [2006], Breger [1986], p. 122-123.

¹⁹¹As Leibniz remarks: “. . . potest etiam fieri, ut quae lineae nobis geometricae non sunt, ut logarithmica fiant aliquando, reperta eas describendi ratione” (AVII3, 38₁₂, p. 486: “it can happen, that

Leibniz ventured the possibility of extending the number of legitimate methods of characterizing curves, either with respect to their constructions or to their properties. The case of the logarithmic curve is noteworthy from this respect: in a tract from 1675 (*De detrimento motus contemplatio geometrica quae mirabili naturae ingenio repraesentat logarithmos*, published only in 1689 with the title: *Schediasma de resistantia medii et motu projectorum gravium in medio resistente*. In *Acta Eruditorum*, January, 38–47), in fact, Leibniz generated it by recurring to a continuous motion ensured by a physical mechanism "which cannot be exactly constructed by the common geometry" (where, I surmise, a curve constructed by "common geometry" should be interpreted as an algebraic curve).¹⁹²

We can suppose that the physical mechanism involved in the continuous generation of the logarithmic curve constituted an acceptable way of describing the curve, a "ratio describendi". Nevertheless Leibniz never specified, in a definite and univocal way, how the extension of geometricity beyond cartesian limits should be effectuated. The redefinition of the cartesian construal of geometricity enhanced by Leibniz is a complex phenomenon, only partially known due the paucity of available documents (mostly confined to his parisian sojourn, from 1672 to 1676), and which certainly requires a supplementary examination into Leibniz's unpublished documents. For this reason I cannot enter this issue here, but leave it to further developments.

8.10 Conclusions

8.10.1 On the limits of cartesian geometry

Let us now resume our analysis of Leibniz's impossibility argument, concerning the quadrature of the central conic sections, and presented in the *De Quadratura arithmetica*.

As I have tried to clarify in my examination, this result can be envisaged as stemming from Leibniz's attempts, conducted between 1675 and 1676, in order to assess the controversy between Gregory and Huygens on the impossibility of squaring the central conic sections analytically.

lines which are not geometrical for us, like the logarithmic, sometimes will become geometrical, once the means for describing them are discovered". See also Knobloch [2006], p. 118).

¹⁹²The motion which generates a logarithmic curve is obtained when a body undergoes a uniform motion, retarded in proportion to the distance traversed. Cf. Knobloch [2006], p. 118-119.

One, or perhaps the main source of inspiration for Leibniz's research on the quadrature of the circle was Huygens himself, who probably encouraged Leibniz to embark in a deeper study of Gregory's *Exercitationes Geometricae* and *Vera Circuli et Hyperbolae Quadratura*, with the aim of answering, eventually, the question whether the circle could be squared geometrically.¹⁹³ I have argued, in chapter 7 of this dissertation, that the controversy between Huygens and Gregory came to an end substantially without any 'winner'. It is not implausible, therefore, that Huygens still cultivated, almost six years later, the hope that Gregory's beliefs on the impossibility of the definite and indefinite quadratures could be refuted, and found Leibniz's inquiry on the arithmetical quadrature promising in order to solve this issue.

Leibniz's examination partly endorsed Huygens' conviction that the arguments advanced in the *Vera Quadratura* and in the *Exercitationes Geometricae* were flawed. Fundamentally, Leibniz reenacted two main objections originally advanced by his mentor Huygens. Firstly, Leibniz judged Gregory's argument presented in proposition XI of the *VCHQ* insufficiently general in order to conclude that no analytical composition could be exhibited, relating a conic sector to the inscribed and circumscribed polygons, constructed according to the protocol specified by Gregory (*VCHQ*, p. 11). Moreover, Leibniz argued that even if no analytical formula could be expressed, that may relate the area of a particular conic sector to the terms of the convergent series of its inscribed and circumscribed polygons, yet the area of the sector could be a quantity analytical with the terms of the series. On this ground, Leibniz introduced and clarified a distinction between the 'universal' quadrature and the 'particular' quadrature of the circle. Although Gregory was right in claiming that an analytical formula relating each circular (or hyperbolic) sector and its inscribed and circumscribed polygons could not be exhibited, he committed an error - argued Leibniz - in deducing from the universal impossibility the impossibility of squaring the whole circle too.

Leibniz's impossibility claim formulated in proposition LI of the *De Quadratura Arithmetica* refers only to the universal quadrature of the circle and the hyperbola, leaving untouched the problem whether the area of the whole circle could be expressed analytically (algebraically) with respect to the radius, or to a square built on it.

¹⁹³Cf. Hofmann [2008], p. LV. See also Hofmann [2008], p. 63, and Probst [2008a], p. 817.

As we are entitled to conclude from the extant documents,¹⁹⁴ by the end of his stay in Paris (namely, September 1676), Leibniz endorsed Huygens' critiques to Gregory's impossibility argument, but diverged from Huygens' position concerning the possibility that the quadrature of the whole circle (namely the definite or "particular" quadrature, in Leibniz's terminology) might be solved by a geometrical construction. Leibniz conjectured, on the contrary, the impossibility of the particular, or definite quadrature of the circle too (in other words, he ventured the hypothesis that the ratio between a circle and a square constructed on its diameter could not be expressed by a rational or an irrational algebraic number), but did not provide, at least by 1676, any argument capable of convincing himself and his fellow geometers.

At any rate, the material presented in this chapter allows us to conclude that the critical evaluation made by Dijksterhuis,¹⁹⁵ according to whom the controversy between Gregory and Huygens remained substantially inconclusive, "... and was doubtless forgotten by most of the participants as were many harsh disputes of the century" should be essentially reconsidered. The evidence deployed in the preceding sections shows that the controversy between Gregory and Huygens was not forgotten and, up to 1676, was still a lively question, since it inspired to Leibniz the impossibility result that he judged as a 'crowning' of his inquiry into the quadrature of the central conic sections.

I also point out that the arguments on the impossibility of the circle-squaring and the hyperbola-squaring problems played a significant role in framing Leibniz's deliberations towards Descartes' view on the extent and limits of geometry.

Although it is difficult to give a unitary description of Leibniz's views about the subject matter and boundaries of geometry, as they underwent several and even dramatic reformulations even in the space of few years,¹⁹⁶ an enduring feature of Leibniz's methodological considerations is the criticism of Descartes' geometry and of his analytical method based on the algebra of segments.¹⁹⁷

As Breger has argued,¹⁹⁸ Leibniz's criticism to Descartes' geometry touches, broadly speaking, two methodological points. The first point of Leibniz's criticism concerned the

¹⁹⁴ Cf., for instance, Hofmann [2008], p. 127, and Knobloch [1999b], p. 220.

¹⁹⁵ Dijksterhuis' opinion can be found in Gregory [1939], p. 480.

¹⁹⁶ An overview of Leibniz's early and rapidly changing views on mathematics is given in Knobloch [2006].

¹⁹⁷ See Breger [1986], the already quoted Knobloch [2006] and Probst [2012].

¹⁹⁸ Breger [1986], p. 123.

type of problems that fell within the scope of cartesian geometry. According to Leibniz, Descartes had restricted the content of geometry to the sole problems reducible to finite polynomial equations, whereas Leibniz believed that the subject matter of geometry ought to include a vaster range of problems and methodologies (the discussion in this chapter has offered us some noteworthy examples).¹⁹⁹

The second, connected critical stance concerns the restriction of Descartes' geometry to problems which demand to find one or more an unknown segments from a given configuration of segments in the plane. In other words, Leibniz considered cartesian geometry as a geometry in which unknown and known quantities of a problem can only be segments.²⁰⁰

In an early unpublished manuscript, titled *Fines Geometriae* ("on the limits, or territories of geometry", from 1673), we encounter a systematic discussion on the meaning of geometry which contains, presumably for the first time, elements of the two lines of criticism just presented. According to Leibniz, geometry could be divided in three realms, on the ground of the domains of problems investigated and the methods involved:

Horum porro omnium rursus tres sunt gradus, est enim geometria vel Euclidea, vel Apolloniana (quam Vieta et Cartesius resuscitavere), vel Archimedeana, cui Guldinus, Cavalerius, alique incubuere.²⁰¹

¹⁹⁹Breger [1986], p. 123. In addressing this criticism, Leibniz had in mind a precise passage of Descartes' geometry, that he read in book III: of Van Schooten's translation: "... per methodum qua utor, id omne, quod sub geometricam contemplationem cadit, ad unum idemque genus problematorum reducuntur, quod est, ut quaeratur valor radicum alicujus aequationis, satis judicabitur, non difficile esse ita enumerare viae omnes, quibus inveniri possunt" (Descartes [1659-1661], vol. I, p. 96). In the original French: "par la méthode dont je me sers, tout ce qui tombe sous la consideration des Geometres se reduit a un mesme genre de Problemes, qui est de chercher la valeur de racines de quelques Equation, on iugera bien qu'il n'est pas malaysé de faire un denombrement de toutes les voyes par lesquelles on les peut trouver, qui soit suffisant pour demonstrier qu'on a choisi la plus generale et la plus simple" (Descartes [1897-1913], vol. 6, p. 475). The passage is even quoted by Leibniz in AVII6, 49₁. See also AVII6, 41, p. 437.

²⁰⁰These methodological remarks were developed since the first acquaintance of Leibniz with Descartes' geometry. They are clearly resumed, for instance, in the following passage, taken from a letter to Mariotte (1674): "Monsieur Descartes a travaillé après Viète, à reduire les questions de Geometrie, aux resolutions de Equations, dont le calcul est entierement Arithmetique. Mais ny luy ny Viète n'ont touché qu'aux Questions Rectilignes, c'est a dire dans les quelle son ne cherche ny suppose que la grandeur de quelques lignes droites, ou figures rectilignes, à quoy se resuident en effet tous les problemes plans, solides, sursolides, etc." (AIII, 1, p. 139).

²⁰¹"Indeed, of all these there are three levels: the Euclidean geometry, the Apollonian (which Viète and Descartes rebuilt), the Archimedean, which Guldinus, Cavalieri and others dealt with.", AVII4, p. 594.

Whereas Euclidean geometry "traces and measures rectilinear figures and finds rectilinear figures of the desired quantity" by use of ruler and compass, "sometimes rectilinear objects of a desired quantity cannot be found but once having described certain other curves, or so-called *loca*. Apollonius illustriously embellished that territory, Viète, Descartes and Sluse widened it".²⁰²

Hence, cartesian geometry was considered by Leibniz as part of a larger field,²⁰³ that Leibniz called "Apollonian geometry", and which included problems requiring the construction of segments by the intersection of "geometrical" curves in Descartes' sense, or problems whose solution was represented by a geometrical curve itself (namely, locus problems). Evidently, Apollonian geometry increases the resolutive capacity of the Euclidean one, as it extends the number of permissible solving methods by allowing the solution of problems expressible in the language of Euclidean geometry (for instance, the trisection of the angle), and the solution of new problems, not expressible in the language of Euclid's geometry (for instance, the construction of the tangent to a parabola).

Nevertheless, Leibniz acknowledged that some of the properties of the very objects belonging to Apollonian and Euclidean geometry, like the measure of arcs or surfaces cut by curves belonging to Apollonian geometry, were not studied with the methods developed within these geometries. As we read in the 1673 tract *Fines Geometriae*, such problems rather belonged to the third type of geometry, that he called "Archimedean".

In 1674 Leibniz returned on his systematic speculation on the nature and division of geometry in similar terms, noting that:

La Geometrie qui passe les Elements se peut diviser commodement, en deux Especies, scavoir celle d'Apollonius, et celle d'Archimede, dont l'une a este resuscitee par Viete et des Cartes, l'autre par Guldin, Cavalieri, et le Pere Gregoire de S. Vincent. Celle d'Apollonius traite des Problemes rectilignes, en donnant la determination de quelques lignes droites demandees par l'intersection des courbes ou lieux appropriez, ce qui se connoist par le moyen des Equations rendues aussi simples que faire se peut. Mais quoyque elle ait besoin

²⁰²*Ibid.*

²⁰³See also AII, 138, p. 481. I provisionally use the term "field" in the sense specified by E. Grosholz: "... a branch of mathematical inquiry with its own distinctive items, constitutive problems, techniques and methods, expectations concerning how classes of problems are to be solved, and sometimes, but not always, formal theories" (Grosholz [1980], p. 167).

de la description des Courbes, elle n'en cherche ny suppose pourtant pas la dimension . . .²⁰⁴

The subdivision proposed by Leibniz were probably directly influenced by his acquaintance with the development of mathematics between the 50s and the early 70s. Indeed new problems, derived from the development in physics or within mathematics itself, had promoted a significant shift in what could be considered the relevant and the peripheral questions in geometry. In particular, the traditional construction problems which acted as the main driving force behind the conception and the genesis of Descartes' geometry lost their impact and became rather peripheral in the mathematical practice of the second half of XVIIth century.

Descartes' geometry did not cover problems of quadratures, its method of tangents was applicable to the sole geometric curves, and it was of little use with respect to the problem of determining a curve, given its tangents (the inverse tangent problem), basically, with respect to the problems forming the 'Archimedean geometry', which gradually became the main issues studied by geometers during the second half of the century. Concomitantly, just like new mathematical problems had made fundamentally obsolete the role of Descartes' geometry in problem-solving activity, so the discovery of new curves, either as objects of study or tools in problem solving, enriched the landscape of mathematical objects, to the effect of making soon overrestrictive the cartesian limitation to geometrical curves (namely, curves constructible by geometric linkages) as the only legitimate ones.²⁰⁵

Eventually, Leibniz criticized the exclusive focus of Descartes' geometry on 'rectilinear' problems reducible to finite polynomial equations as an untenable constraint in the light of the contemporary mathematical advances. Indeed, in Leibniz's view, Descartes had assumed that:

Methodo sua geometriam ad perfectionem perductam esse, quanta ab homine optari possit; nullum esse problema, cuius non aut solutionem aut solvendi impossibilitatem monstret. Certas sibi rationes esse praescribendi limites intellectui, deniendique quicquid aliquando inveniri possit. Sed quantopere in eo negotio lapsus sit, vir caetera utique magnus, docuit eventus. Crediderat

²⁰⁴AVII6, 7, p. 88.

²⁰⁵Bos [2001], p. 424; Knobloch [2006], p. 118.

enim arte humana curvam rectae aequalem inveniri non posse quod in Geometria diserte satis expressit, forte quod ex ea quam sequebatur geometriae methodo, cui nihil addi posse putabat aditus et ad hanc speculationem nullus aperiretur. At Wrennus certe ac Heuradius ac novissime Hugenus praeclaris speciminibus, spem intellectui humano reddidere.²⁰⁶

Leibniz was certainly inspired in this criticism by Descartes' claim on the non-comparability between straight and curved lines, that he must have perceived as an excess of self-confidence on Descartes' side.²⁰⁷ Indeed, a major limit of cartesian mathematics was, in Leibniz's view, that of having artificially and unjustifiably restricted geometry to a domain in which all questions about solvability of problems could be answered. By doing so, Descartes would have wrongly believed to have offered with his *Géométrie* a solution to Viète's problem - or 'meta-problem' as we may call it - of "leaving "no problem unsolved".

This presumption, Leibniz emphatically claimed in the above passage, entailed also the relevant epistemic consequence of imposing undue limitations to the power of our intellect: the concern for the constitution of a closed domain, in which any problem could be ranged into a class and solved accordingly (Leibniz had probably also in mind the closing lines of *La Géométrie*) overcame the concern for adapting our mathematical knowledge in order to meet the demands posed by new unsolved problems.

Hendrick van Heuraet is mentioned by Leibniz, together with Wre and Huygens, as a mathematician whose results contributed to give confidence back to the human intellectual endeavors constrained by Descartes.²⁰⁸ One can find clear and evident reasons:

²⁰⁶AVII,4, p. 594-595: "By his method geometry had been led to perfection, so much as can be wished by men : there is no problem, whose solution or impossibility to solve he will not show. [Descartes also claimed] that he had the methods to prescribe certain limits to the intellect and to define anything that could be discovered some time. But the event taught how much a man so great in all other things erred in this task. In fact he had thought that no curve equal to a straight line could be found by human art, a view which he expressed in the geometry clearly enough, maybe because by means of this geometrical method that he followed, to which he believed nothing could be added, no approach could be opened to that speculation. But surely Wren, and Heuraet, and most recently Huygens gave hope back to human intellect with noteworthy examples".

²⁰⁷See, for instance, also: A III, 1 p. 139; VII6, n. 7, p. 88.

²⁰⁸The mention is not casual, as Van Heuraet is often named by Leibniz in connection with the discovery of rectifications. Heuraet, together with Huygens' and Wren's, was in fact involved in the debate about the discovery of the rectification of an algebraic curve : I remind that Van Heuraet's letter was written in 1658 and published in 1659. The same results had already been obtained by W. Neil, in 1657, although they were exposed by Wallis only in 1659, in his treatise on the Cycloid, probably as a reaction against the primacy of Van Heuraet's discovery. Particular instances of Van Heuraet's theorem had been proved

solving for the first time the problem of rectifying a geometrical curve constituted a momentous achievement in the history of early modern mathematics, and Leibniz, writing about fifteen years after these facts, was prompt to recognize their historical value, especially when confronted with Descartes' own skepticism. In the years after 1673, while adhering to the main tenets of his criticism to Descartes' geometry, Leibniz further articulated it and examined, among 1674-76, the technique of rectifications explained in Van Heuraet's letter.²⁰⁹

Leibniz was not the only one who hailed Van Heuraet's result with the intent of criticizing Descartes' own views. Let us recall, for instance, Sluse's opinion, evoked in ch. 6, about how Van Heuraet's result uncovered the "error made by Descartes".²¹⁰

It should be pointed out that, by mentioning van Heuraet, Leibniz possibly wanted to criticize Descartes' own opinion on the extent and limits of geometry, not the opinion of the mathematicians who promoted cartesian mathematics. Indeed, especially in the light of van Heuraet's result, they were not always prompt to accept Descartes' presupposition on the non-comparability between straight and curve lines.²¹¹

by Fermat (1660) and Huygens in 1657.

²⁰⁹Leibniz referred to: "the method of Heuraet" or "the calculus of Heuraet" in AVII5, 30 (in the tract titled: '*Curvae mensurabiles heuratianae*'), and AVII5, 52. See also III,1 67, where Leibniz wondered whether one could extend this method so as to give the rectification of the hyperbola, a still unsolved problem by then (III,1 67, p. 307).

²¹⁰See Ch. 6, sec. 6.3.

²¹¹It must be pointed out that Descartes' *Géométrie* was far from being perceived as a clear, consistent and well structured text by his contemporaries. Van Schooten's editorial work can be indeed conceived as the project of giving a more consistent and gapless structure to the *Géométrie*, in order to make it suitable as an instructional text. It is perhaps significant that Van Schooten did not comment about Descartes' claim that straight and curve lines cannot be set into an exact proportion: by promoting Van Heuraet's result, he might have wanted to downplay and conceal Descartes' claim and stress how the method of geometry could be profitably employed for solving certain rectification problems, instead. The defense of cartesianism promoted by the mathematician and Leibniz's friend E.W. Tschirnhaus (relevant exchanges between this mathematician and Leibniz are contained in vol AIII1, and AIII2 of Leibniz's mathematical correspondence) can be possibly read as a consequence of this attitude. While Tschirnhaus admitted, in the course of his 1675-1676 correspondence with Leibniz and other mathematicians, the possibility of solving certain rectification problems algebraically, and therefore geometrically (he was likely thinking of the rectification of the quadrato-cubic parabola) he excluded that problems like the quadrature of the circle could be given other solutions but mechanical ones. It seems, therefore, that he restricted the validity of Descartes' belief about the non-comparability between straight lines and curves only to circular arcs, which merely entailed the impossibility of rectifying the circumference and any of its arcs. It must be recalled, on the other hand, that Leibniz was not alone in mentioning van Heuraet's name with the intent to criticize Descartes' geometry. A similar attitude was taken, around the same years, by the English mathematician John Collins. In an important exchange with Tschirnhaus, which took place in 1676, Collins disparagingly listed several flaws which could be found in Descartes' *Géométrie*, and on this ground he argued that this text was outdated. Among the relevant errors, Collins mentioned Descartes' opinion that curves and straight lines were not amenable to comparison, and listed

But even if van Heuraet's result could refute Descartes' belief on the non comparability between the straight and the curve, it remained a special contribution, and on its ground a general analytical treatment of rectifications and quadratures based on Descartes' algebra of segments could not be grounded. This conclusion is an immediate consequence of the impossibility of giving an algebraic quadrature of the conic sections, known by Leibniz through Gregory's books, as we have seen, and reproved in a way judged more rigorous by the former.

One of the meta-theoretical consequence of this impossibility result was to cut short any hope to discover a general method of rectifications based on Descartes' algebra of segments. This impossibility claim might have exerted, I surmise, a dependable role in persuading Leibniz to maintain the distinction between the apollonian and the archimedean domains of geometry, and to consider these domains separate on the ground of the methods of analysis that could be specifically employed in each one of them.

Our previous exposition allows to establish that Leibniz's concrete efforts in proving the impossibility of giving a general quadrature of the circle in algebraic terms started around the beginning of 1676, but also that Leibniz had matured a belief in such impossibility since the previous years. For instance, this very idea surfaces in a letter probably sent to Gallois, from december 1675, and connected with a version of *De quadratura arithmetica* Leibniz had terminated during that month. We read, in Leibniz's words:

Il est constant que la meilleur voye de rendre les problemes de Geometrie traitables, est celle de les rapporter aux nombres. Ce que Viète et Des Cartes ont fait dans les problemes rectilignes, en les reduisant aux Equations d'Algebre, comme si on cherchoit que des Nombres. Mais dans les problemes curvilignes, lors qu'il s'agit de trouver les centres de gravité et la dimension des lignes courbes, des figures, des surfaces et des solides, on ne peut pas encore renfermer l'inconnue qu'on cherche dans une equation; et les trop grandes promesses de Mons. Des Cartes, qui parle dans sa geometrie, comme si tous les problemes se reduisoient aux equations, se trouvent courtes.²¹²

Van Heuraet as one of the mathematicians who contributed to show the falsity of this belief. Finally, the view that van Heuraet's rectification acted as a refutation of Descartes' belief might have become a *communis opinio* in the subsequent years. Still at the end of the century we find this opinion voiced, for instance, by Jakob Bernoulli in his annotations to the 1695 latin edition of the *Géométrie*. In fact Bernoulli explicitly mentioned van Heuraet in connection with the criticism to the belief that curves and straight lines were not amenable to comparison (see Descartes [1695], 1695, p. 436).

²¹²AIII1, 73, p. 358.

A similar point is made, few months later, in AVII6 41, a text which Leibniz intended to use as preface to the *De quadratura arithmetica*, and later discarded:

...cum curvilineae quantitates, et quae ex his pendent anguli, logarithmi, centra gravitatum, calculum ingrediuntur; cessat Algebra, quae hactenus publice nota est. Talia autem problemata ad aequationem non revocantur; nec dici potest cujus sit gradus quadratura circuli, planumque an solidum locum desideret, cum dici possit gradus esse nullius nisi forte infinitesimi.²¹³

In the above passages, Leibniz clearly connects an impossibility claim (briefly speaking, the claim that we cannot express ‘curvilinear problems’ by finite polynomial equations) to the critique on the limits of Descartes’s and Viète’s analytic method.

In the backdrop of these passages, the argument on the impossibility of squaring the central conic sections can be interpreted as implying that the class of ‘curvilinear problems’ concerning the quadrature of figures or the rectification of arcs cannot be reduced to finite algebraic equations, and consequently, cannot fall into the scope of the class of problems and methods that Leibniz had baptized "apollonian geometry".

Consequently, not even van Heuraet’s method, despite its applicability to the rectification of a class of curves, can be configured as a general method of rectification, since even the quadrature of geometrical curves like the conic sections cannot be reduced to finite algebraic equations, and therefore solved geometrically.

Leibniz’s pseudo-impossibility theorem, enunciated in the closing proposition of *De quadratura arithmetica*, proved that the boundary between Apollonian and Archimedean geometry, conceived as separate domains of geometry, was rationally grounded.

8.10.2 The constitution of transcendental mathematics and Leibniz’s new calculus

It is clear from the foregoing considerations that the boundary between the separate domains of Apollonian and Archimedean geometry was dictated by the limitation of the resolutive capacity of Descartes’ method.

²¹³AVII6, 41, p. 437: "As soon as the curvilinear quantities, and those which depend on the angles, logarithms, centers of gravity, enter the calculus, the algebra which is commonly known comes to a stop. Such problems, actually, are not reducible to an equation, nor it can be said which is the degree of the quadrature of the circle, whether it requires a plane or solid locus, since we can say it is of no degree, or maybe infinitesimal".

We have already discussed about the appearance of the term ‘transcendental’ (*transcendens*) in Leibniz’s mathematics, in order to refer to curves and problems which trespassed the constructional possibilities of cartesian geometry, or could not be reduced to Descartes’ algebra of segments.

Let us recall that a ‘transcendental problem’ was originally characterized negatively by Leibniz, as a problem irreducible to a finite algebraic equation. as pointed out in Breger [1986] (p. 125), Leibniz should have presumably ranged, among transcendental problems, the universal squaring of the central conic sections, together with the general angular section and the problem of dividing a ratio into an arbitrary number of parts (both are discussed, let us recall, in the last proposition of *De quadratura arithmetica*, and are considered irreducible to a unique algebraic equation).

We have also hinted to the fact that Leibniz accompanied this negative characterization with a positive one. Consistently with his general attitude in mathematical and scientific investigations, Leibniz did not merely see the territory of Archimedean geometry as a collection of diverse problems untreatable by finite cartesian analysis, but envisaged the possibility of setting up a ‘universal’ method of problem-solving, which, as he wrote in a text of 1674, *De la méthode de l’universalité*:

nous enseigne de trouver par une seule opération des formules analytiques et des constructions géométriques générales pour des sujets ou cas différens.²¹⁴

Early modern mathematicians had certainly framed general methods, either geometrical (like in Cavalieri, Torricelli and also in Gregory, at least in the context of the *GPU*) or algebraic (as in Wallis’s or Mercator’s quadrature of the hyperbola) in order to find the areas of the greatest number of curvilinear figures and solids, by replacing the classical appeal to the method of exhaustion with routine calculations or geometric transformations between figures.

What was lacking, though, at least from Leibniz’s perspective, was a calculus, namely a symbolism together with rules in order to operate on these symbols, which could solve the problems of squaring an arbitrary figure or rectify an arbitrary arc, or the problem of finding an (arbitrary) curve given its tangents.

²¹⁴Couturat [1903], p. 97. See also Mahnke [1925], p. 60.

In the light of the pseudo-impossibility theorems proved in the *De quadratura arithmetica*, Descartes' algebra of segments did not seem to offer an adequate model for such a universal method. Also in the backdrop of the inadequacy of the cartesian calculus, Leibniz often invoked, as an alternative method of discovery within the territory of Archimedean geometry, a "new calculus", endowed with "equations of a new kind", "new constructions" and even a "new kinds of curves":

Neque aequationes neque curvae Cartesianae nos expedire possunt; opusque est novi plane generis aequationibus, constructionibus curvisque novis; denique et calculo novo, nondum a quoquam tradito, cujus si nihil aliud saltem specimina quaedam, mira satis, jam nunc dare possem. Sed quid Cartesium in errorem duxerit, iudicatu facile est, versatior erat in Apollonio quam Archimede; et in Vieta quam Galilaeo; unde nondum illi occurrerat via ac ratio perveniendi ad dimensiones curvilinearum: cumque nimia forte sui [fi?]ducia, eosdem methodi suae et cognitionis humanae limites esse putaret, oblitus solitae circumspectionis, relationem inter rectas curvasque negavit libro Geometriae secundo ab hominibus cognosci posse. Quae postea eventus refutavit. Haec ideo monui, ut intelligant homines, esse quasdam in Geometria inveniendi artes, quas in Cartesio frustra quaerant.²¹⁵

These *desiderata* did not remain hollow phrases. In fact, Leibniz's study of series applied to investigating problems of quadratures (a noteworthy example was the quadrature of a sector of the circle, examined in the previous sections) and of tangent-determination would lead, from 1675 onwards, to forge the programme later known as 'Leibnizian calculus'.²¹⁶

The apparatus of Leibniz's calculus appeared in print in 1684, in the famous article: 'Nova methodus pro maximis et minimis, itemque tangentibus, quae nec fractas, nec irrationales quantitates moratur, et singulare pro illis calculi genus', *Acta Eruditorum*, (1684), (467–473+ Tab. xii. October issue), but were devised by Leibniz since October 1675.²¹⁷

²¹⁵AVII6, 49₁, p. 504: "Neither cartesian equations nor cartesian curves can help us, we need equations of a plainly new kind, constructions and new curves. Indeed we need a new calculus, not yet transmitted by anyone, of which I may now at least give wonderful examples. It is easy to judge what led Descartes to error: he was more expert in Apollonius than Archimedes, and in Viète than Galileo, but the path and the method to obtain, from there, the measurement of curves had not come to him yet."

²¹⁶I will address, for an exhaustive account of Leibniz's calculus, to the so far unsurpassed Bos [1974].

²¹⁷AVII5, 38, 40, 44. See also: Scriba [1963], p. 114.

Moreover, as we have seen, Leibniz referred to symbolic, "transcendental" expressions already from 1675 (and occasionally before), in order to represent "mechanical" curves and to treat problems. In a letter from 1679, Leibniz explained to Huygens that he had enhanced algebra so much beyond the limits of Descartes and Viète, as these ones advanced over ancient geometers. Leibniz was confident, in fact, that he had found out a method of discovery in order to solve in a systematical and terse way the 'most important problems' of geometry, where Descartes could only proceed, so to speak, *à tâton*:

Je pretends donc qu'il y a encor une toute autre analyse en Geometrie que celles de Viète et de des Cartes: qui ne sauroient aller assés avant, puisque les problemes les plus importans ne dependent point des equations, aux quelles se reduit toute la Geometrie de M. Des Cartes. Luy même non obstant ce qu'il avoit avancé un peu trop hardiment dans sa Geometrie (sçavoir que tous les problemes se reduisoient à ses equations et à ses lignes courbes) a esté contraint de reconnoistre ce defect dans une de ses lettres, car M. de Beaune luy ayant proposé un de ces estranges mais importans problemes *Methodi Tangentium inversae*, il avoua qu'il n'y voyoit pas encor assés clair. Et j'ay trouvé par bonheur que ce même probleme pourra estre resolu en trois lignes par l'analyse nouvelle dont je me sers. Mais j'irois trop avant si je voulois entrer dans le détail, et il suffit de dire que la Geometrie enrichie de ces nouveaux moyens peut devancer celle de Viète et de des Cartes autant et plus sans comparaison que ces Messieurs n'ont surpassé les anciens. Et cela non pas en curiosités seulement, mais en problemes importans pour la mecanique.²¹⁸

This 'new analysis' represented, in Leibniz's views, not only as an enrichment of Viète and Descartes' methods, but as the refutation of the belief, attributed by Leibniz to Descartes, that several problems in geometry, labelled by the latter as "curiosités",²¹⁹ could not be subsumed under an appropriate and general method of analysis.

A bright example of the ease and progress brought into problem-solving techniques by Leibniz's calculus was de Beaune's problem, an instance of inverse tangent problem, namely the problem of finding a curve given the properties of its tangents.²²⁰ In Leibniz's

²¹⁸ AII2, p. 662.

²¹⁹ Cf. Mahoney [1984], in particular, p. 419.

²²⁰ The case of De Beaune's problem is discussed by Leibniz, in particular, in AVII5, 90, from July 1676. See also the commentary by Belaval in Belaval [1960], p. 311-312. The modern equivalent of this class of problems is the solution of a first-order differential equations.

view, his *analyse nouvelle* could solve in an expedient way ("ce même probleme pourra estre resolu en trois lignes") and by means of an optimal symbolic notation a whole class of transcendental problems, namely quadrature and inverse tangent problems, which represented a crucible for the cartesian paradigm in problem solving, since they often involved non-algebraic solutions.

Further considerations on the organization of transcendental mathematics can be found in the published article *De Geometria Recondita* (1686), a late article with respect to the temporal band I am considering, which can be read, nevertheless, in continuity, for its content and argumentative style, with Leibniz's mathematical research started during the Paris period.

In this article, Leibniz ordered transcendental problems, namely problems of "no definite degree" ("nullius sunt certi gradus") into two classes: the first kind derived from the section of the angle, the second kind derived from the general section of a ratio (namely, the insertion of an arbitrary number of mean proportions between given segments). The transcendental nature of both classes of problems can be justified in the backdrop of the impossibility of giving an algebraic quadrature of a circular sector or arc, and the quadrature of an hyperbolic sector, respectively. Indeed the problem of the general section of the angle corresponds, in analytical terms, to the problem of computing such expressions as $\sin(nv)$ or $\cos(nv)$, where v is a given angle, whereas the problem of the general section of a ratio corresponds to the problem of studying the associated logarithmic function.

On the ground of this broad classification, Leibniz envisaged the possibility of classifying unknown quadratures by reducing them, through the symbolic manipulations enhanced by the differential and integral calculus, either to the problem of the universal quadrature of the circle or of the quadrature of the hyperbola. I have not been able to ascertain, though, how far this view fit within the common views of the practitioners by the end of XVIIth century, nor whether Leibniz envisioned further classes of transcendental problems, beyond the two discussed so far.²²¹

However, it is worth noting that in presenting such ideals of classification, Leibniz explicitly referred to Descartes' and Pappus' views on geometricity. In the *Geometria recondita*,

²²¹Concerning Leibniz's assessment of transcendental mathematics and the reception of his late XVIIth century contemporaries, see: Bos [1988].

for instance, Leibniz evoked the criticism moved by Descartes to Pappus' alleged restriction of geometry to the sole plane and solid problems (or curves), and turned this very criticism to the separation between geometrical and ungeometrical (or mechanical) curves introduced by Descartes in *La Géométrie*.²²²

The attempt to remodel the scope and limits of cartesian mathematics, according to a similar project to the one undertaken by Descartes, when he remodeled the organization of mathematics in Pappus' *Collection*, shows that Leibniz did not conceive Descartes' programme, aims, and underlying organization as inconsistent or flawed. Leibniz's criticism was rather directed, as we have seen, to challenge the limits of cartesian analysis.

This implies that the principles and methodologies around which cartesian geometry is organized or that were brought to the fore by cartesian geometry, for instance the classification of problems and curves according to their degree, or the procedure for the construction of equations, might be still taken as a useful model in order to organize the new field of transcendental mathematics. Of course, it makes no sense to apply criteria based on finite equations in order to study problems irreducible to finite polynomial equations, but it makes sense to query whether, in the domain of transcendental equations, curves and problems, there were similar structural constraints as those set up by Descartes within his geometry. Can we single out requirements exerting, in the domain of transcendental mathematics, a prescriptive role analogous to the one exerted by the constraint on simplicity (cf. ch. 4) in the organization of problems and solving method in cartesian geometry? Did the problems of the quadrature of the central conic sections (particularly, the quadratures of the circle and the hyperbola) played, according to Leibniz, a central role in the organization of the subject matter of transcendental mathematics, analogous to that of Pappus' problem in cartesian ordering of problems and curves? Answering these questions requires to explore a mathematical practice that lies beyond the chronological interval we have set for our study, although it takes, as a starting point, the very results explored in this chapter.

8.10.3 Appendix: primary sources

Gottfried Wilhelm Leibniz: *Sämtliche Schriften und Briefe*. Ed. Akademie der Wissenschaften zu Göttingen and Berlin-Brandenburgische Akademie der Wissenschaften: Akademie-Verlag, 1923- :

²²² Cf. for instance: LSG, V, p. 226, p. 228.

- AIII1: 1663-1685. *Sämtliche Schriften und Briefe Zweite Reihe: Philosophischer Briefwechsel* (Leibniz [1926]).
- AIII1: 1672-1676. *Mathematischer, naturwissenschaftlicher und technischer Briefwechsel*, published in 1976. Editor: Joseph Ehrenfried Hofmann (Leibniz [1976]).
- AIII2: 1676-1679. *Sämtliche Schriften und Briefe. Dritte Reihe: Mathematischer, naturwissenschaftlicher und technischer Briefwechsel* (Leibniz [1995a]).
- AIII3: 1680-1683. *Sämtliche Schriften und Briefe. Dritte Reihe: Mathematischer, naturwissenschaftlicher und technischer Briefwechsel* (Leibniz [1995b]).
- AIII4: 1684-1687. *Sämtliche Schriften und Briefe. Dritte Reihe: Mathematischer, naturwissenschaftlicher und technischer Briefwechsel*. (Leibniz [1995c]).
- AVI2: 1663-1672. *Sämtliche Schriften und Briefe Sechste Reihe: Philosophische Schriften Bd. 2:* (Leibniz [1966]).
- AVII1: 1672-1676. *Mathematische Schriften: Geometrie - Zahlentheorie - Algebra* (Leibniz [1990]).
- AVII3: 1672-1676. *Mathematische Schriften: Differenzen, Folgen, Reihen* (Leibniz [2003]).
- AVII4 1670-1673. *Infinitesimalmathematik* (Leibniz [2008a]).
- AVII5 1674-1676. *Infinitesimalmathematik* (Leibniz [2008b]).
- AVII6 1673-1676. *Arithmetische Kreisquadratur* (Leibniz [2012]).

Leibniz' Mathematische Schriften. Ed. C. I. Gerhardt. 7 vols. Berlin, 1849-63:

- LSG3 (2 vols) Correspondence with Jacob Bernoulli, Johann Bernoulli, Nicolaus Bernoulli, 1855, 1856 (Leibniz [1849-63a]).
- LSG5 *Dissertatio de arte combinatoria; De quadratura arithmetica circuli, ellipseos et hyperbolae ; Characteristica geometrica. Analysis geometrica propria. Calculus situs ; Analysis infinitorum*, 1858 (Leibniz [1849-63b]).

Chapter 9

Epilogue

9.1 A survey of early-modern impossibility results

In this study, I have undertaken the task of exploring XVIIth century geometry, especially concerned with the impossibility of constructing the problems of trisecting an angle, inserting two mean proportionals and solving the quadrature of a sector of the circle or the hyperbola, with respect to their outlook, their inner structure and their roles in the contemporary mathematical practice.

My inquiry into XVIIth century impossibility results has started with an investigation of some methodological aspects of Descartes' *La Géométrie*, where we can also find the first known proofs that solid problems (i.e. the trisection of the angle and the insertion of two mean proportionals) cannot be solved by ruler and compass.

As I have argued in chapters 3 and 4, one of Descartes' driving aims in composing this treatise was to offer guidelines in order to undertake the ambitious programme of solving all geometric problems, each according to its most adequate means. In order to realize this programme, Descartes elaborated a method of analysis, that should be applicable, in principle, to all problems in geometry, and was based on the reduction of any problem to an finite polynomial equation. Moreover, he introduced clearcut criteria for selecting the most adequate solution for any problem. In brief, in Descartes' view, a problem should always be solved by the 'simplest' curves, according to a dimensional, or algebraic notion of simplicity.

Two tasks became therefore crucial for the completion of the cartesian programme: firstly to circumscribe the number of acceptable curves in geometric problem solving; and secondly, to determine which curves are most appropriate in order to solve a given problem.

The impossibility results expounded in Descartes' geometry emerged in connection with both tasks. In the context of Descartes' canon of problem solving, deliberations about the impossibility of solving a geometric problem by certain means (I have investigated them thoroughly in chapter 4), can be interpreted as establishing which curves are inappropriate, because too simple, for a problem at hand: a paradigmatic case at point is the impossibility of solving problems reducible to cubic or quartic equations by straight lines and circles, discussed in Book III of *La Géométrie*.

My investigation about the criteria in order to separate acceptable from non acceptable curves has also shown that an impossibility claim entered into Descartes' articulate answer to this methodological question. In my view, argued in chapter 5 and 6 of this study, the impossibility of knowing with exactness the proportion between curvilinear arcs and segments of a straight line exerts a foundational role in the economy of Descartes' geometry, since it contributes to exclude certain curves (like the spiral and the quadratrix) from the number of acceptable ones.¹

Descartes did not mean, when he termed the circle-squaring problem an 'impossible problem', that this problem could not be solved in any manner whatsoever.² The quadrature of the circle was 'impossible', in the sense that it was unsolvable within Cartesian geometry, in which the exact proportion between straight and curvilinear segments was denied. Even if no justification for the exact unknowability between curvilinear arcs and segments is advanced by Descartes, this unjustified assertion may be explained in the light of the conviction, of Aristotelian origin, that curves (and in particular arcs of the circle) and straight lines cannot be compared. I have argued for this thesis in chapter 6, on the basis of a shared opinion among scholars.³

During XVIIth century, the very tradition on whose grounds Descartes had probably stated the illegitimacy of the circle-squaring problem was "knocked down on the head".⁴

¹My reading is particularly indebted to Mancosu [1999], and Mancosu [2007].

²*Cf.* chapter 6, p. 271, *sparsim*.

³*Cf.* the following works, often cited in this study: Bos [2001], Baron [1969], Mancosu [1999], Mancosu [2007].

⁴Hofmann [2008], p. 101.

Let us recall that the belief in the exact unknowability of the proportion between straight and curvilinear arcs involved, in virtue of Archimedes' theorem 1 of the *Dimensio Circuli*, the impossibility of solving, in an exact and geometrical way, the circle-squaring problem.⁵ As I have illustrated in this study (chapter 7), the impossibility of solving in an exact way the quadrature of the circle was precisely the conclusion questioned by James Gregory, in the *Vera Circuli et Hyperbolae Quadratura* (1667, hereinafter *VCHQ*).

In this work, Gregory chose the problem of the quadrature of the central conic sections as the theme of his investigation. A variant of the classical Archimedean squeezing procedure is applied in order to perform an analysis of the problems of squaring a sector of a central conic, arbitrarily chosen. It is then inquired, in the same book, whether a finite algebraic equation, relating the circular or hyperbolic sectors to the converging series of inscribed and circumscribed polygons might be obtained as the end result of this analysis. Gregory's conclusions, as we know, is a negative one: he claimed and allegedly proved that there is no finite algebraic relation between a given sector of a central conic section and the terms of the double sequence formed by the inscribed and circumscribed polygons to the sector itself.

In order to argue for this impossibility result, Gregory relied on the cartesian algebra of segments, but also on two innovations that cannot be found in Descartes' geometry. Firstly, I surmise, he tacitly assumed the possibility of employing the algebra of segments in order to measure surfaces of figures. Secondly, he elaborated a 'new analysis' in order to reduce problems of quadrature to analytical expressions (namely, convergent sequences).

By establishing that no simpler, nor more geometrical solution to the problem of squaring a sector of a central conic could be given, Gregory's impossibility result did not entail that this problem had not solutions at all.

On the contrary, Gregory solved this problem by means of certain 'non-analytical operations', i.e. operations which involved the use of infinite converging sequences in order to express the area of the sought-for sectors. Gregory's impossibility result eventually legitimated the geometrical nature of the solutions obtained by infinite series, because it showed that no simplest solutions were in fact available (i.e. there is no algebraic or

⁵See, on this concern, Descartes' letter to Mersenne, from 31 March 1638. See Descartes [1897-1913], vol. 2, p. 90-91.

analytical formula expressing the area of a sector of a central conic). But if one can argue that no simpler method exists, in order to treat the quadrature of a central conic sector, than methods relying on infinite sequences and series, then such methods should be admitted as legitimate, provided one intended to warrant the solvability of problems of quadratures too.

The boundary between legitimate and illegitimate problems was questioned along similar lines in Leibniz's *De Quadratura Arithmetica*.⁶ Indeed, Leibniz exhibited a solution, in the 'positive' part of this treatise, consisting in expressing the relation between the length of a circular arc and its corresponding tangent through an infinite series. This solution did not comply with the standards of exactness in force of *La Géométrie*, since it was not recast into a finite algebraic equations, nor it showed a geometric constructional procedure (at most, it showed an approximate, or mechanical construction), but it was nevertheless judged an 'exact' one, certainly in the backdrop of a different ideal of exactness and geometricity than the one in force in cartesian geometry.⁷

Of course, one might still desire a 'perfect' solution to quadrature problems, namely a simpler solution obtained by a finite, algebraic formula or through a geometric construction, in the cartesian sense. However, the impossibility argument discussed in the *De Quadratura Arithmetica* made it obvious that searching for such a solution for the problem of squaring any sector of a central conic would be a loss of time and energy, in the same way as any attempt to solve the problem of trisecting an angle, or duplicating the cube by ruler and compass.⁸

Leibniz broadened the methods and language of mathematics, and castigated what he considered the restricted views of his predecessors, and among them, principally the views of Descartes (*cf.* ch. 8, in particular section 8.10, p. 450 *ff.*). The ambitious aim of solving all problems of geometry was still one of Leibniz's *desiderata*, but in a different sense than the one presumably intended by Descartes. The latter had in fact restricted the scope of the quantifier 'all': 'all' problems did not take into account such problems in

⁶I have discussed Leibniz's reception of James Gregory in ch. 8, section 8.6.1 of this dissertation.

⁷Even if the meaning of 'exact' in the ambit of Leibniz's practice differed from the meaning of the same word in cartesian geometry, it was nevertheless well defined, as we can evince from this study, ch. 8, sec. 8.5.2.

⁸On a related note, concerning the quadrature of the whole circle, we can recall that Leibniz wrote to Conring that his own solution to the circle-squaring problem is not what mathematicians commonly desire, for instance a geometrical construction, but it is what they *should* desire, namely the exhibition of π through a series (Leibniz to Conring, 19.3.1678, AII, 1, p. 402).

which the comparison between straight and curvilinear segments were involved, at least. On the contrary Leibniz considered these kinds of problems as part of geometry, together with the methods applicable to their solution (See ch. 8, sec. 8.10).

In summary, my study has brought to the fore the importance of impossibility results in early modern geometry on two levels: these results constituted relevant mathematical advances *per se*, because they represented novel achievements in the landscape of early XVIIth century mathematics, but they also had a prominent methodological role, because they framed the range of possible solving methods and contributed to the erosion of existing restrictive methodologies. For example, the impossibility of trisecting an angle by ruler and compass had the practical consequence of dissuading any effort towards the search for plane solution and, concomitantly, it could be seen as warranting the acceptance into geometry of other solving methods beyond the ruler and the compass.⁹

This function of early modern impossibility results is also evident in the case of the circle-squaring problem, that I have examined in Gregory's and Leibniz's accounts. The impossibility of solving this problem by algebraic methods acted as a sort of 'backward legitimation' in order to alter the bounds of geometry and of the methods considered exact.

It should be pointed out that even if these impossibility results warranted the inclusion in geometry of new curves and new solving methods, they were not the sole nor the primary forces acting in this process of extending the bounds of geometry. Gregory's and Leibniz's investigations, for instance, developed in the backdrop of different conceptions of exactness than the one in force within Cartesian geometry. These conceptions were prompted by changes in the practice (for instance, changes in the kinds of problems which attracted most efforts and attention in a certain period of time) and often, these shifts in the conceptions of exactness represented a necessary condition for legitimation of new curves and new methods in geometry.

9.2 The structure of early modern impossibility results

9.2.1 The role of algebra in XVIIth century

The early modern period brought about an outstanding development and diversification of algebraic techniques, together with their incorporation into geometric pursuits, in

⁹The point is raised by J. Gregory, in *GPU*, *preface*, fol. 10.

particular into the analysis of geometric and arithmetical problems. According to a well-known historiographical hypothesis, algebraic reasoning allowed the geometer to reformulate and solve arithmetic or geometric problems in a systematical and effective way: it allowed to apply the same type of constructions to a vast range of problems (let us think, for instance, of the technique for the construction of equations), and it possesses algorithmic, or quasi-algorithmic character (let us think, for example, of the techniques of reducibility. In this way, the use of algebra could amplify the resolatory capacity of classical geometric techniques or, in the views of some, restore the methods of discovery concealed by the ancients.¹⁰

But efficiency and systematicity in problem-solving may not be the only contributions that algebra had to offer to geometry. I have argued at length (in ch. 4), that algebra represented the most adequate means, in Descartes's views, in order to reformulate Pappus' classification, because it allowed to associate to geometric objects (curves) that can be generated in a multiplicity of ways, an invariant like the degree of the associated equations.

This reformulation also involved a new understanding of the constraints to which the solutions of a problem should undergo: on one hand, one should not employ curves of too high a degree in order to solve a certain problem, and on the other, one should not try to solve a problem by curves of too low a degree. Since Descartes was confident that algebraic manipulations of equations could offer a method in order to decide the equation in the lowest possible degree associated to a problem or to a curve, namely, to decide

¹⁰Baron [1969], p. 5; Boyer [1959], p. 98. The conviction that analytical methods, integrated with algebraic symbolism, could improve and replace the ancients methods of analysis, which in contrast allowed one to come to the solutions of problems only in a haphazard way, was also an ingrained view among early modern authors. *Cf.*, for instance, a passage from Descartes' correspondence, already quoted in this study (chapter 3, p. 114) where it is remarked how the "analysis of the moderns" is "clearer, easier and less liable to errors" than that of the ancients (Descartes [1897-1913], vol. 2, p. 83). Also in *La Géométrie*, Descartes lamented the prolixity and unorderliness of ancients mathematicians, who filled their treatises with the solutions to problems encountered by chance (Descartes [1897-1913], vol. 6, p. 376). In a similar vein, Barrow explained, in his latin translation of Archimedes' works, that one was entitled to translate the analytical method of Archimedes into the language of algebra, because, besides leaving unchanged the geometric content of the original, algebra either unravelled the true method of discovery adopted by the ancients, or offered a systematic way of deducing the same conclusions reached by them, apparently only by chance (I will quote, for conciseness, the english translation to be found in Whiteside [1961], p. 192): "This [the language of algebra] is the exact equivalent of the proportion deduced by Archimedes (and, to insert a general remark, it reveals sufficiently the sort of analysis he used; for that he arrived at the result through application of these various compositions, divisions, alternations and inversions he produces is almost beyond belief: and if he did so, it must be supposed by chance rather than by any design that he came on the true solution, and that this happened time after time can scarcely be believed)".

of their natures, he must have also thought to possess a method in order to avoid those errors issued from the violations of the requirement of Pappus, duly reinterpreted as a requirement of simplicity.

I surmise that such a reformulation of Pappus' requirement by means of algebraic considerations could have opened up the possibility of stating and justifying certain conditional impossibility claims in the form of mathematical results, namely theorems, or 'pseudo-theorems' (I shall discuss this term in the sequel) of impossibility. This consequence is not fully brought to the fore in Descartes' geometry, since the argument he advanced in order to justify that problems reducible to quartic or cubic equations cannot be solved by ruler and compass is based on a mixture of algebraic and geometric reasons (ch. 4, sec. 4.6.1), but it would be perfectly clear to his successors, like Gregory and in particular Montucla, who relied on the technique for the construction of equations in order to assess Descartes' impossibility results (ch. 4, section 4.6.2).

The systematicity and efficiency of algebraic techniques paved the way in order to apply these techniques to the proof of other impossibility statements, like those related to the indefinite, or universal quadrature of the circle.

I can only level here the question whether ancient, classical geometry did possess analogous resources, through which Greek geometers, for instance, could configure impossibility arguments analogous to the early modern ones. On the other hand, I shall turn now to sketching, in the light of the case studies examined in this dissertation, an answer to the following question: in which sense the employment of algebra in early modern impossibility results differed from the employment of algebra in actual impossibility extra-theoretical theorems?

With hindsight, I have called the impossibility of solving the problems of duplicating the cube, trisecting the angle and squaring the circle by ruler and compass "extratheoretical impossibilities".¹¹ From our vantage point, in order to prove that a construction by prescribed means is impossible in a certain theory C (like Euclid's plane geometry), a theory C' is required in order to model the former theory and thus give a mathematical proof of impossibility.¹² Our setting C' might be then represented by the coordinate

¹¹See chapter 1, section 1.3.2.

¹²We may take the following definition of theory: "A piece of mathematics characterized by the domain of objects which it is about, that is (...) a mathematical theory is identified if and only if a certain domain of objects is so, and - if this is the case - I say that this theory is about these objects" (Panza

geometry over the field \mathbb{R} of real numbers. In this case, statements concerning geometrical entities belonging to C are translated into statements of C' , concerning algebraic or analytical objects, and the very impossibility of solving a problem by certain means of construction can be formulated, in the logical framework of the real cartesian plane, as a theorem stating that a certain element in the cartesian plane, corresponding to the abscissas and the ordinates of the points, or to the lengths of the segments to be constructed, does not belong to the field associated to the geometrical constructions in respect of which the impossibility at stake is formulated. In the end, algebra and analytic geometry offer a 'lens' in order to examine and interpret the impossibility of solving the problems of duplicating the cube, trisecting the angle and squaring the circle.

A received view among mathematicians even projected back onto Descartes the creation of analytic geometry as we conceive it today. This is the same view presupposed by Hilbert, when he wrote in his lecture on Projective geometry that:

Da war es *Descartes* - der Begründer der neueren Philosophie - welches ein *neues allgemeines Princip in die Geometrie* (1637) einführte. Einführung der Koordinaten in die Geometrie (. . .) Dieser Gedanke macht mit *einem Schlage* jedes *geometrische Problem der Analysis zugänglich*. So wurde *Descartes der Schöpfer der analytischen Geometrie*.¹³

However, the investigation led in the previous chapters has brought to light some of the peculiarities of early-modern analysis and algebra, which make the hypothesis of Descartes as an originator of modern analytic geometry historically untenable.

In a famous article on the meaning and origins of algebra, Hans Freudenthal noted that there is "no Supreme Court" to decide what algebra is.¹⁴ On the ground of this admission, he recognized that certain procedures and techniques of the past have the same right to be considered part of the algebraic thinking as techniques that we now recognize, without qualms, as belonging to algebra, and thus he felt justified in applying modern algebra in order to understand ancient examples.

[2007], p. 94).

¹³Hilbert [2000a], p. 24: "Then came Descartes - the founder of modern philosophy - who brought a new general principle in geometry (1637). The introduction of the coordinates in geometry (. . .) This thought made, with one blow, all geometrical problems available to analysis. So Descartes became the originator of analytic geometry".

¹⁴Freudenthal [1977], p. 193.

I do not want to contest this viewpoint, which has turned out fruitful in the past,¹⁵ but I suggest that Freudenthal's remark on the absence of a last authoritative word about the essence of algebra, opens up for the possibility that the word 'algebra' might have had different meanings in different historical contexts. In particular, it might have a different meaning in today mathematical practice with respect to the practice of XVIIth century geometers (an analogous reasoning might holds for the word 'analysis').

9.2.2 Algebraic proofs of impossibility theorems

In the ambit of Descartes' mathematics, algebra constituted a system of symbols (letters and arithmetical symbols) together with a set of operations (addition, multiplication, division and root extraction) and relations (the only relation denoted in the system is that of equality. Other relations, like the relation of order, usually belong to the metalanguage, while relations of proportionality are subsumed under equations), that could be applied either to arithmetic or geometric quantities.¹⁶ Hence early modern geometers could deal with several algebras, according to the particular kind of quantities of which they obtained. These particular algebras are to be considered "assertive", according to the terminology employed in chapter 3, and used originally in Panza [2005].

Moreover, in so far formal or structural properties of algebraic expressions could be referred either to geometric or arithmetical objects, they could be studied independently from either of these disciplines. As I have examined in chapter 3 (p. 120ff.) there is also room to speak of "algebra", in the context of early modern geometrical practice, in order to indicate the formalism shared by several assertive algebras, and those properties which depend solely on this formalism: Descartes, for instance, relied on this notion of algebra when he devoted an important section of Book III of *La Géométrie* in order to illustrate the techniques for the transformation of equations, and the connected study of their properties, such as reducibility.¹⁷

¹⁵Moreover, this critical task has been duly taken over by S. Unguru, for example in his famous: Unguru [1975].

¹⁶See also Panza [2005], p. 35.

¹⁷Among the cases discussed in this dissertation, it is also illuminative to mention Gregory's definition of 'analytic composition' as a finite composition of arithmetic operations applied to unspecified 'quantities' (see df. 6, p. 9 of his *VCHQ*). In this context, quantities can be either arithmetic or geometric, but their nature is not declared. This silence is perfectly justified on the ground that the operations here defined, which can hold both of geometric and arithmetical quantities, are structurally identical.

The employment of formal properties of algebraic expressions, like equations, and on their rules of transformation is particularly evident in the cases of impossibility results examined in this dissertation. For instance, the reasoning deployed in proposition XI of James Gregory's *Vera circuli et hyperbolae quadratura* (discussed in this study, ch. 7, section 7.4) relies on considerations inherent to the degree and the structure of the polynomials obtained as the end result of the analysis of the circle (and hyperbola) - squaring problem; such properties are independent of the nature of the quantities these polynomials design.¹⁸ Even Leibniz's argument, expounded in the last proposition of the *De quadratura arithmetica*, makes appeal to such formal properties of equations: as we have discussed in chapter 8 (particularly in section 8.6), in order to argue indirectly that no finite degree polynomial equation can express the relation between an arbitrary arc and its tangent, he employed the method of undetermined coefficients, and utilized the irreducibility of certain equations associated to angular divisions: in both cases, Leibniz dealt primarily with the structure of equations rather than the objects these equations denote.

But I stress that equations, at least in the contexts I have examined (that is from the beginning of XVIIth century to 1675-1676), may not to be understood as algebraic objects belonging to a theory autonomous with respect to geometry and arithmetic.¹⁹ On the contrary, these algebraic expressions always depend, for their meaning and justification, on geometry or arithmetic. This interpretation complies with the considerations, somewhat common among early modern geometers, of algebra as an 'art', or an instrument subservient to both the aforementioned disciplines: geometry or arithmetic.²⁰

¹⁸Incidentally, I remark that Gregory himself acknowledged the algebraic nature of his proof, and hoped for a clearer geometric argument in order to ground the impossibility of effectuating the squaring of a central conic sector. See, for instance, *VCHQ*, p. 5: "It is certainly true that I have not reduced the whole of my demonstration to the language of geometry, indeed, in order to do this, one would need a non small volume on the mutual relations and on the incommensurability between analytical quantities, in a kind that I am surprised that noone has ever written about". Gregory's later studies on the theory of proportions and on book V of Euclid's *Elements* may be related to the same desideratum. Unfortunately, these studies, of which there is a record in the catalogue of Gregory's writing conserved in Edinburgh's library (See Gregory [1939], p. 40-42), are no longer extant.

¹⁹According to the definition of theory I have endorsed above, in note 12. It cannot be excluded that, under different understandings of what a theory is, algebra might be considered a theory as well (*cf.* Freguglia [1999b]).

²⁰As we have discussed in chapter 7 (see, specifically p. 297) this thesis was emphasized in the treatise *De concinnandis demonstrationibus geometricis ex calculo algebraico*, written by Frans van Schooten and published posthumously by his brother Peter (Descartes [1659-1661], vol. 2. See also Brigaglia [1995], p. 231). In this final work, Frans van Schooten shared in fact the conviction that algebra was, at least in the context of Descartes' geometry, a language which coded geometric information, and consequently, algebraic expressions could always be 'decoded' and interpreted in terms of the language of classical geometry. At its core, the project he presented in *De concinnandis* aimed to convince his

I therefore surmise that, when formal properties of equations were singled out and studied *per se*, in the context of XVIIth century geometry, they did not concern equations properly, but schemes of equations, namely metalinguistic expressions that stand for an infinity of equations and could refer, in their turn, either to geometric or arithmetic quantities.²¹

This interpretation warns us against projecting back to XVIIth century mathematics our own disciplinary and theoretical distinctions: even if, in the historical setting of XVIIth century geometry, a correspondence between geometric constructions and arithmetical operations is explicit and well justified on some occasions (as our examination of the *Géométrie* has brought to the fore), algebra did not frame an autonomous theory C' , which could describe facts about a different theory C (C might be Euclid's geometry, or one of its suitable extensions in order to include conic sections and other curves constructible via linkages).

9.2.3 Early modern constructions and constructibility

Another aspect of today impossibility theorems is the possibility of mirroring successive geometric constructions into a succession of algebraic operations, by means of cartesian coordinate geometry, so as to associate to different curves different ranges of problems solvable via these curves.²² For instance, any finite succession of constructive steps, which involves the sole use of ruler and compass, employed according to Euclid's clauses fixed in the *Elements*, can be associated to a finite succession of operations yielding rational and quadratic irrational quantities only. The employment of the ruler and the compass can be then distinguished from constructions employing higher degree curves, by considering the succession of algebraic operations associated with the latter curves,

readers that any algebraic manipulation (rewriting) of a finite polynomial equation, based on defined syntactical rules, could be systematically interpreted in terms of operations among proportions, or in terms of constructions and results expressible in the language of classical geometry. But perhaps, one of the first formulations of the thesis that algebra did not have its own objects, but dealt with either geometry or arithmetic was not given by an early modern geometer. Indeed, this thesis is explicit in the work of the Persian mathematician Omar Khayyam. As he wrote in a treatise named *Algebra*: "Whoever thinks algebra is a trick in obtaining unknowns has thought in vain. No attention should be paid to the fact that algebra and geometry are different in appearance. Algebras are geometric facts which are proved" (quoted in Michael N. Fried [2001], p. 26). In other words, algebra was a suitable language for expressing geometric facts proved geometrically.

²¹The term 'schema' is employed, in the context of cartesian algebra, in Panza [2005], p. 43.

²²Cf. Coolidge [1940], p. 53: "It is clearly impossible to make an adequate discussion of the possibilities of various geometrical instruments without the aid of analytic geometry. I do not know who first grasped this idea, but it seems evident enough to-day".

and the quantities which can be constructed thereby.²³

In order to decide whether a given construction problem in the plane is solvable by the employment of a certain type of curves, it is sufficient to consider whether the equation associated to the problem can be solved²⁴ by applying, to the lengths of the given segments of the problem, a finite succession of those (and only those) algebraic operations associated to the allowable geometric constructions.

In virtue of this twofold algebraic characterization of problems and constructive procedures, obtained through the use of analytic geometry, each construction instrument or curve can be associated to a range of solvable problems. A logical characterization of the ‘constructive power’ of various instrument can be thus obtained, in principle, in the following way. Broadly speaking, if the same range of problems corresponds to two different constructing instruments, then these instruments can be regarded as equivalent. On the other hand, if the range of problems solvable by one instrument includes the range of problems solvable by the second one, then the constructive capacity of the former will be greater than the constructive capacity of the latter.²⁵

In contrast, even if Descartes’ algebra of segments could offer a correct analytical reduction of several geometric problems into algebraic equations, and could thus recast the property of being constructible by certain means (for instance, ruler and compass) into the property of being relatable to an equation in a certain degree (in the case of plane problems, these are reducible to quadratic equation), it did not as well set up an explicit translation into algebra of the stepwise procedures involved in the construction of a geometric problem.

As I have argued at length in this study, Descartes’ canon of construction, which became paradigmatic during XVIIth and part of XVIIIth century, is composed by an analytical part, in which a certain construction problem is reduced to an algebraic equation, and by a synthesis, in which this equation is constructed through the intersection of a couple of curves. Consequently, proving that the use of certain lines cannot solve a problem at

²³*Cf.* the elementary exposition by G. Castelnuovo, in Enriques [1912], vol. 1, p. 315.

²⁴In this context, ‘solving an equation’ has a sensibly different meaning than in the context of early modern geometry. A solution is obtained, in the former case, when the unknown can be expressed as an algebraic function of the coefficients of the equation: no geometric construction by the intersection of curves is needed anymore.

²⁵I am indebted on the exposition contained in Enriques [1912], vol. 2, p. 583.

hand boils down to proving that the algebraic equation associated to the latter cannot be constructed by intersecting a pair of lines among those admissible.

Fundamentally, what seems to be missing from this technique was an explicit study of the successive structure of the auxiliary construction involved into the solution of a problem.²⁶ In fact, even if Descartes did not completely overlook this aspect, at least for what concerns special constructive tools²⁷ he certainly downplayed it, and restricted his considerations on the construction of a problem to the sole construction of the equation obtained as the end result of the analysis of the latter.

As a result of this missing connection between geometric constructions and algebraic operations, it seems that differences in the constructional power of curves were justified, at least in cartesian geometry, only on the basis of qualitatively geometrical considerations.²⁸ It is the case, for instance, of the constructive power of the circle, on one hand, and of the conic sections, on the other: Descartes acknowledged that the range of problems solvable by the former was more restricted than the range of problems solvable by the latter, but could not express such a difference in algebraic terms. Both curves belonged in fact to the same class, as far as we consider their algebraic characterization given in *La Géométrie*, because they can be associated to quadratic equations. The only explanation ventured by Descartes on the reason why the sole use of the circle (plus the straight line) did not allow one to construct certain problems, solvable by conic sections (or by a circle and a conic section) instead, concerned the different curvature of these curves. I have stressed elsewhere the unrigorous character of Descartes' argument (see chapter 4, p. 164).

A possible exception, in the context of XVIIth century geometry, might be represented by Gregory's characterization of analytical quantities, offered in the introductory part of

²⁶See Lützen [2010], p. 31.

²⁷For instance, Descartes mentioned, although in passing, that auxiliary constructions should be accomplished by adding all the lines that seemed necessary for the construction of a problem. Moreover Descartes assumed, but without delving into this issue, a correspondence between stepwise constructions by circles and straight lines and successive algebraic reductions involving quadratic equations, for instance when he considered the factorization of cubic equations into quadratic ones.

²⁸This being said, the successive structure of constructions was not completely overlooked in Cartesian geometry, though. For instance, Descartes briefly mentioned, in illustrating the guidelines of his problem-solving methodology, that auxiliary constructions might be accomplished by adding all the lines that seemed necessary for the construction of a problem (Descartes [1897-1913], vol. 6, p. 372). Moreover, he assumed (without delving into the issue, though) a correspondence between stepwise constructions by circles and straight lines and successive algebraic reductions involving quadratic equations, involved, for example, in the algebraic reduction of a cubic equation to a quadratic one (when this was possible).

VCHQ. Starting from definition 5, for example, Gregory managed to clarify the meaning of ‘analytical composition’ and ‘analytical quantity’ in terms of a finite succession of algebraic operations, and conversely, he characterized non geometrical constructions in terms of the non analytical nature of the quantities and the operations exhibited.²⁹ However, it is difficult to evaluate Gregory’s influence over the successive generations, and in particular over the gradual emergence of analytic geometry, during XVIIIth century. It can be observed, at any rate, that not even the algebraization of Descartes’ impossibility result, later obtained by Montucla (ch. 155, sec.4.6.2), did introduce a correct and transparent algebraic characterization of the employment of the diverse constructing instruments, but kept the same structure of Descartes’ argument, and did not really succeed in shifting its focus from the attempt to prove that a certain equation associated to a problem could not be constructed through a pair of selected curves, to the proof that the roots of this equation could not be expressed as the result of a sequence of algebraic operations, associated to a finite sequence of constructions obtained through allowable tools (for instance, ruler and compass), and applied to some given objects.³⁰

In conclusion, my study had revealed that the very idea of ‘extratheoretical impossibility’, as I have characterized it in the foregoing discussion, had not yet pierced its way through the considerations of early modern geometers. In order to sweep away conceptual and terminological confusions, one should more properly talk about ‘pseudo-theorems’ and ‘arguments’ of impossibility, in order to speak about those claims, together with their correlated justificatory packages, formulated in the historical setting of XVIIth century mathematics. With this clarification in mind, I want to suggest that pseudo-impossibility theorems and arguments are not merely ill-formed theorems and proofs, or statements which we could accept in our modern mathematical practice, provided adequate additions and revisions were supplemented. In the light of our previous considerations, it seems plausible to conclude that the shift from pseudo-impossibility to impossibility theorems required a deep conceptual change in mathematics in the backdrop, instead of a mere refinement of the techniques available at a certain time and within a certain community.

9.2.4 From the constructive paradigm to the conceptual paradigm

Further investigations are certainly welcome, in order to integrate the already existing research and to cast light on the transition from pseudo-theorems to extratheoretical theorems of impossibility.

²⁹See chapter 7, section 7.3.2.

³⁰See also Lützen [2010], p. 31.

As it has been convincingly argued in recent publications (for instance Otte [2003], Lützen [2009] and Sørensen [2009]), extra-theoretical impossibility theorems became an integrated part of mathematics in the backdrop of a change in the image and structure of mathematics itself, initiated in the first half of XIXth century, and definitely assessed at the turn of XXth century. Impossibility theorems stood as an exemplary instance of such a change, to the point that they might be considered the "birth certificate of pure modern mathematics".³¹

This shift can be understood in terms of a passage from a 'constructive paradigm', predominant in XVII and XVIII century geometry, to a 'conceptual paradigm'. The emergence of the latter paradigm was envisioned in these terms by the mathematician N. Abel, in his tract *Sur la résolution algébrique des équations* (1839):

Un des problèmes les plus intéressantes de l'algèbre est celui de la résolution algébrique des équations (...) mais malgré tous les efforts de Lagrange et d'autres géomètres distingués, on ne put parvenir au but proposé. Cela fit présumer que la résolution des équations générales était impossible algébriquement; mais c'est sur quoi on ne pouvait pas décider, attendu que la méthode adoptée n'aurait pu conduire à des conclusions certaines que dans le cas où les équations étaient résolubles. En effet, on se proposa de résoudre les équations, sans savoir si cela était possible (...) pour parvenir infailliblement à quelque chose dans cette matière, il faut donc prendre une autre route. On doit donner au problème une telle forme qu'il soit toujours possible de le résoudre (...) au lieu de demander une relation dont on ne sait pas si elle existe ou non, il faut demander si une telle relation est en effet possible.³²

In the passage above, Abel sketches what he considers a 'new road' in order to tackle the problem of solving the quintic equation. Instead of directly searching for a solution in a haphazard way ("à l'aide d'une espèce de tâtonnement et de divination", Abel [1839], vol. 2, p. 24), Abel recommended that a mathematician should reformulate the problem of searching for a solution to the quintic expressible through a closed algebraic formula in terms of the coefficients of the equation, in order to transform it into the question about whether such a solution by radicals is possible. Abel noted that the change from a question about the existence of a solution to a question about its possibility contained the 'germ of its solution' already in its enunciation. Two possible answers are in fact

³¹Otte [2003], p. 182. See also Lützen [2009], p. 389-390.

³²Abel [1839], vol 2., p. 185. See also Otte [2003], p. 181, for an English translation.

admissible once we ask about the possibility of the solution to a problem: either ‘yes’, and the problem is solvable, or ‘no’, and the problem cannot be solved. If this answer is negative, a theorem of impossibility will ensue, like the one proved by Abel himself in his *Mémoire*, considered a a solution to the original problem by all means.³³

Abel insightfully anticipated a passage from the mere search for constructive solutions to problems, as the unique ground in order to establish their existence, to an interest for questions about the possibility of solutions. I could not ascertain whether he explicitly discussed the possibility of submitting other problems (as those constructive problems of geometry the duplication of the cube, the trisection of the angle or the squaring of the circle) to a similar shift or whether, more probably, he inspired other mathematicians. Let us recall, indeed, that the first proofs of the impossibility of trisecting the angle and duplicating the cube were obtained by P. Wantzel few years after Abel’s *Mémoire*, in the article *Recherches sur les moyens de reconnaître si un Problème de Géométrie peut se résoudre avec la règle et le compas*, published in *Liouville Journal des mathématiques pures et appliquées* (1837).³⁴

Around the same years, Joseph Liouville (1809-1882) proved another outstanding impossibility result: a certain class of integrals cannot be expressed in closed forms,³⁵ and Niels Henrik Abel (1802-1829) also proved that quintic equations cannot admit solutions by radicals in his *Mémoire sur les équations algébriques où on démontre l’impossibilité de la résolution de l’équation générale du cinquième degré* (1824).³⁶ Wantzel and Liouville, whose impossibility theorems were published within few years one from the other, were probably herald of Abel’s change of perspective.

³³Cf. Lützen [2009], p. 389.

³⁴The main theorem proved by Wantzel in this article can be reformulated, according to J. Lützen as it follows: "the irreducible polynomial (with rational known coefficients) having a constructible line segment x_n^0 as its root must have a degree that is a power of 2" (Lützen [2009], p. 378). In a first step, Wantzel translates the geometric problem of constructing a segment by ruler and compass into an algebraic problem (i). He then shows that (ruler-and-compass) constructable problems lead to equations of degree 2^n ($n \in \mathbb{N}$) (ii). Subsequently, he sets out to prove that, under certain assumptions, the equations so obtained are irreducible over $\mathbb{Q}[x]$ (iii). Wantzel then translates the problems of trisecting an angle and duplicating the cube into algebraic equations, and claims (without proof) that these equations are irreducible (over $\mathbb{Q}[x]$) (iv). Wantzel’s proof is defective: its major gap can be located at step (ii), as it is stressed in Lützen [2009], p. 378ff. A correct proof of the impossibility of solving the trisection of the angle and the duplication of the cube in the style and spirit of Wantzel’s original proof is offered in the classical study by F. Klein (Klein [1895]), who works out the results obtained by Julius Petersen.

³⁵Cf. Lützen [1990], chapter IX.

³⁶For Abel, in particular see: Sørensen [2004] and Sørensen [2009].

Only quite later, in 1882, F. Lindemann published the rigorous proof that the number π is ‘transcendental’ (namely, it satisfies no algebraic equation with integer coefficients), and therefore the circle-squaring problem cannot be solved algebraically.³⁷

This result was obtained in the same vein of the previous impossibility theorems, but as the examination contained in the already quoted Lützen [2009] has shown, a *décalage* occurred systematically between the first published proofs of geometric impossibility theorems and their acceptance and circulation in the community of mathematicians. It seems, in fact, that it was only in the last part of the century that their value became known and appreciated, and they acquired a legitimate standing in mathematics on a par with positive solutions to problems.

Echoes of the recognized importance of impossibility theorems can be found among David Hilbert’s considerations, expounded in the epoch-making paper on *The Problems of Mathematics* (1900):

In recent mathematics (*der neueren Mathematik*) - Hilbert wrote- the question as to the impossibility of certain solutions plays a pre-eminent part, and we perceive in this way that old and difficult problems, such as the proof of the axiom of parallels, the squaring of the circle, or the solution of equations of the fifth degree by radicals have finally found fully satisfactory and rigorous solutions, although in another sense than that originally intended.³⁸

Whereas Abel may have intuited such a change of perspective, when he spoke, in the passage reported above, about taking another route in problem-solving, Hilbert was fully conscious that such a new route had been traced and become mainstream towards the end of XIXth century.

In this setting, the concept of ‘geometric problem’ acquired a new meaning, since it went from an inquiry about the existence of a solution to an inquiry about its possibility. The new sense in which problems could be understood and treated can be gleaned through the case of the quadrature of the circle, one of the paradigmatic examples mentioned by Hilbert in the above passage. In the formal framework of XIXth century, in fact, algebra and analysis offered a method for deciding an answer to the question about whether it was possible to solve this problem by certain means (for instance, the ruler and the

³⁷See Fritsch [1984].

³⁸Hilbert [1901], eng. tr. in Hilbert [2000b], p. 409. Cf. Mancosu [2011], p. 199.

compass), and eventually allowed mathematicians to prove the negative answer in the form of an extra-theoretical impossibility theorem.

In this ‘conceptual paradigm’, the solution of a geometric construction problem did not necessarily coincide with the exhibition of a construction. This phenomenon was salient in the case of elementary problems in geometry, to which the classical construction problems belong. For those cases, a method was available, to Hilbert and his contemporaries, in order to decide whether a problem can be solved by prescribed means. Hence, according to the new meaning of ‘problem’, a proof that the circle cannot be squared by ruler and compass would count as a proper solution to the quadrature problems. Likewise, we can prove that a regular polygon of 17 or 257 sides is constructible by ruler and compass, without giving the effective construction. In the end, mathematicians could deal with constructibility as if it were a property of mathematical objects, namely problems, on a par with other properties, and for this reason the role of effective constructions of the classical construction problems became subsidiary to the proofs of their constructability (or non constructability).

On the contrary, in a classical, constructive setting, in which we can situate the historical episodes discussed in this dissertation, questions about the feasibility of a certain problem by prescribed means could be certainly addressed, but they were not preceded by the crucial question about the possibility of solving the problem at hand, and their answer stood by no means as a solution to the problem. Concomitantly, mathematicians lacked a fully-fledged, systematic method in order to decide whether a problem was constructible by prescribed means. As Abel brilliantly resumed it, when a ‘classical’ geometer set out to solve a problem, he started by searching for an adequate solution, even if it should be pointed out that, contrarily to Abel’s views, this search might not always have been led *à tâton*.

9.3 Impossibility arguments as answers to metatheoretical questions

It should be noted that early modern geometers criticized the procedures of the ancients as based on discoveries met by chance, without a proper method. Consequently, attempts to find the ‘most adequate’ methods in order to tackle a given problem can be seen as responses to this concern.

In particular, the cases discussed in this dissertation have brought to the fore that one of the salient roles of impossibility results within the constructive paradigm of early modern geometry was methodological, and consisted in contributing to the finding of the most adequate solutions for a problem at hand, by excluding inadequate, or ‘simpler’ types of solutions.

I suggest that the methodological role of impossibility results, in XVIIth century geometry, can be deepened in the light of a useful conceptual distinction, originally introduced by Leo Corry, in Corry [2008]. According to Corry, two sorts of questions related to a mathematical discipline can be distinguished and discussed. The first sort of questions concerns the subject matter of a discipline, while the second sort of questions concerns the discipline *qua* discipline.³⁹

For instance, the solution of the angle trisection deployed in Pappus’ Book IV of the *Collection* (Cf. ch. 2, p. 50), Descartes’ solution of the angle trisection or insertion of two mean proportionals contained in Book III of *La Géométrie* (cf. ch. 3, p. 173) and Leibniz’s solution to the circle-squaring problem exhibited by means of the convergent alternating arctangent series (ch. 8, sec. 8.2) respond to a question related to the subject matter or "body" of a discipline. These are, as Corry calls them, answers to ‘first-order’ questions or problems (namely: ‘to find a third of a given angle’, or ‘to exhibit the area of a circle, or of the fourth of a circle, with unitary diameter’).

On the other hand, Pappus’ division of problems into classes and his criterion in order to decide the most adequate solution to a problem, that we have discussed in chapter 2, or the distinctive criterion in order to separate geometrical and mechanical curves introduced by Descartes in *La Géométrie* (discussed, in this study, in chapter 5) shape the image of knowledge, as they concern geometry *qua* geometry, not particular problems formulated within the discipline itself. Likewise, Descartes’ criterion for choosing the best one among several, equally sound solutions to a given problem does not offer a solution to a particular problem, but prescribes how we must proceed, in general, when solving problems in geometry. All claims which concern a discipline *qua* discipline can be called ‘metatheoretical claims’. Metatheoretical claims and guiding principles of a discipline form a layer of questions, and answers to those questions, which arise from the body of knowledge, but cannot in general be answered within this body. We may call this second layer: ‘the image of knowledge’.

³⁹Corry [2008], p. 411.

I surmise that, in the context of ancient mathematics, claims that a problem cannot be solved by certain means (for instance the unsolvability of solid problems by ruler and compass) belong to the image of mathematics: impossibility statements had rather the methodological role of principles regulating the practice of problem solving than a proper mathematical theorem.⁴⁰ Possibly for this reason, no proof of this impossibility claim was advanced in the context of Greek mathematics: the justification of such a claim depended on arguments derived from the tradition of a practice.

Impossibility claims had the same role in early modern geometry: they belonged to the image of mathematics, rather than to its body. For instance, as discussed at length in this study, we can ascribe to impossibility statements the role of expressing the limits of applicability of a method, and the corresponding role of setting the boundaries of a theory. Let us consider Descartes' claim that solid problems cannot be solved by plane means or, more generally, that a problem cannot be solved by too simple methods with respect to its class. Our study of the third book of *La Géométrie* makes it clear that role of such impossibility statements is to restrict the choice of the adequate means in order to solve a certain problem, and therefore to offer some guidelines for the search of correct solutions.⁴¹

In the context of Gregory's inquiries into the quadrature of conic sections, as well as in Leibniz's *De Quadratura Arithmetica* too, impossibility results concerned the image of mathematics, because they answered, negatively, to a question about the resolutive capacity of cartesian geometry, pointing towards its limits, and warranting the necessity of extending the accepted problem-solving methodologies, if one wanted to square any sector of a central conic.

Generally speaking, the impossibility statements I have studied in this dissertation, both in antiquity and in the early modern period, did concern the activity of problem solving rather than particular problems. They were, therefore part of the image of mathematics. But my research into early modern impossibility results has shown another important novelty with respect to the mathematics of antiquity: in the setting of early modern geometry, impossibility claims were justified mathematically, albeit in an informal way. In other words, they can be considered as theorems or, according to the terminology I have introduced above, 'pseudo-theorems'.

⁴⁰See chapter 1, p. 26

⁴¹*Cf.* ch. 4, sec. 4.6.1.

I can thus conclude by observing that XVIIth century impossibility results are distinct from the normal activity of problem-solving and theorem-proving, on one hand, and on the other from philosophical or methodological considerations on mathematics, which do not rely on the inferential machinery characteristic of mathematical thinking (as the recourse to codified inferential steps and deductive structures, symbolization, apparatus of calculus).

Whereas the latter activity was common since ancient mathematics (it is sufficient, for example, to think of Pappus' classification of problem or of his description of the analysis and synthesis), the impossibility results presented and argued by Descartes, and subsequently, by Gregory in the *VCHQ* and by Leibniz in the *De Quadratura arithmetica* might represent the first attempts to answer questions concerning the image of mathematics (what are the limits of a certain method of discovery? Which tool can best effectuate the analysis of a given problem, like the quadrature of the circle?) by mathematical means: namely, by means of algebra (and in particular by means of Descartes' algebra of segments).

As noted by Corry (in Corry [2008]) a distinctive feature of mathematics with respect to other disciplines concerns the possibility of treating mathematics itself as its own subject matter; in other words, the possibility of 'transferring' the image of a discipline into the body of the discipline itself: this is what we may call the "reflexive activity of mathematics".⁴² We might venture the conjecture that the pseudo-theorems of impossibility discussed in this study constituted salient examples of a practice that might be characterized as "reflexive knowledge", namely a thinking about mathematics that is carried out by means of mathematical resources.

The programme sketched by Gregory in the preface of the *Vera circuli et hyperbolae quadratura*, in which the systematic treatment of impossibility results (let us recall that Gregory evoked, among these impossibility results, the impossibility of solving solid problems by ruler and compass, the impossibility to prove in which case a given, algebraic, equation cannot be decomposed into factors, and thirdly the connected problem to assess the curves of minimal complexity necessary for the construction of a given problem) is

⁴²Corry [2008], p. 413. This possibility is concretized, today, in what we call 'metamathematics'. For instance, it belongs to metamathematics the study of formal systems and their properties, like logical strength (how much can be done using given mathematical methods) unprovability (insufficiency of given methods to answer certain mathematical questions), and finally, the study of existence and non-existence of algorithms (I am particularly indebted, for these distinctions, to A. Bovykin).

emphasized as a "new field" of research, is exemplary of an awareness for mathematics as an enterprise that could inquire, by mathematical means, about his own methods.⁴³

The very fact that impossibility results should and could be proved by mathematical means can be considered as an outstanding advance in the mathematical practice of XVIIth century. This was part of a tacit legacy that cartesian Geometry left to later mathematicians. Descartes did present unrigorous mathematical arguments in order to prove certain impossibility claims, although he did not emphasize this achievement in *La Géométrie*. I surmise that mathematicians like Gregory or Leibniz were nevertheless persuaded by the examples contained in *La Géométrie* in order to inquire about the possibility of extending Descartes' algebra of segments to the squaring an arbitrary sector of a central conic, and came out with a negative answer. The impossibility of squaring analytically the central conic sections can therefore be considered part of the cartesian legacy to subsequent XVIIth century geometers.

The research undertaken in this dissertation confirms that the legacy of Descartes' geometry did not merely concern the level of mathematical discoveries and techniques, but it also concerned ways of shaping the mathematical practice. I am thinking, for instance, of the attempts to dispose, by appealing to mathematical arguments, of certain questions about the image of mathematics: which are the adequate means in order to solve a given problem? Which are the limits of a given method? As we have seen, pseudo-theorems of impossibility had an essential role in answering these questions.

Descartes' influence in shaping the mathematical practice did not confine itself to the episodes analyzed in this study, namely to Gregory's and Leibniz's mathematics. With respect to the issue of impossibility in geometry, this influence might be widespread and concern numerous mathematicians, both 'major' and 'minor' characters in the history of the period, who might have reflected upon the issue of impossibility (let us think, for example, of Wallis, Newton, but also of Sluse, Van Schooten, often quoted in this study, and Carlo Renaldini, who influenced Gregory's reception of cartesian geometry). Moreover, a 'mathematical thinking' about the image of mathematics might be also found

⁴³It is not clear, though, how far Gregory views (certainly far-fetched for the time) received audience and circulated: let us recall, once more, that Gregory's influence on the development of mathematics is skewed and difficult to trace, due to his scarce production and his peripheral position in the mathematical community of his time, which contrasted with the circulation of his mathematical ideas among the contemporaries, as recent studies have shown, and as my contribution has, I hope, helped to reveal as well.

among XVIIth and XVIIIth century mathematicians, beyond the chronological limit I have set to this study (I am thinking, specifically, of Tschirnhaus, Leibniz himself, Euler and Jacob Bernoulli).

These directions, together with many other ones, can be explored in future research. After all, the study of ‘reflexive activity of mathematics’ in early modern geometry, which includes the study of impossibility as one of its main chapters, represents a new and living subject matter, which my dissertation, I hope, has pioneeristically contributed to unfold.

Bibliography

Niels H. Abel. *Oeuvres complètes de N. H. Abel, mathématiciens, avec des notes et développements, rédigées par ordre du Roi, par B. Holmboe*. Christiania, 1839.

An account of some Books. *Philosophical Transactions of the Royal Society*, 3:685–688, 1668.

Ammonius. *On Aristotle's Categories*. Cornell University Press, 1992.

Kirsti Andersen. The Method of Indivisibles: Changing Understandings. *Studia Leibniana (special issue)*, 14:14–35, 1986.

Apollonius. *Opera (2 vol.)*. Leibniz, Teubner, 1891-1893.

Andrew P. Arana. *phd Dissertation*. 2003.

Archimedes. *Archimedis Opera Omnia cum commentariis Eutociis*. Teubner, 1881.

Aristotle. *On the heavens*. Oxford, Clarendon Press, 1922.

Aristotle. *Aristotle's Physics*. Clarendon Press, 1936.

Aristotle. *Categories, De interpretatione*. Clarendon, Oxford, 1963.

R. Arthur. Leibniz's syncategorematic infinitesimals. *Archive for History of Exact Sciences*, 67(5):553–593, September 2013.

Richard Arthur. The remarkable fecundity of Leibniz's work on infinite series. *Annals of Science*, 63/2:221–255, 2006.

Robert Audi. *The Cambridge Dictionary of Philosophy*. Cambridge University Press, 2 edition, September 1999.

Margaret Baron. *The Origins of infinitesimal calculus*. Dover, 1969.

- Antonio Becchi, Domenico Bertoloni Meli, and Enrico Gamba. Guidobaldo del Monte (1545-1607). May 2013.
- Oskar Becker. *Das mathematische Denken der Antike*. Vandenhoeck and Ruprecht, 1957.
- Isaac Beeckman. *Journal tenu par Isaac Beeckman de 1604 à 1634. Publié avec une introduction et des notes, par C. de Waard. 4 vols.* M. Nijhoff, La Haye, 1939-1953.
- Yvon Belaval. *Leibniz critique de Descartes*. Gallimard, 1960.
- Giulia Belgioioso and Pierre Costabel. *Descartes: il metodo e i saggi. Atti del convegno per il 350 anniversario della pubblicazione del Discours de la méthode e degli Essays*. Istituto della enciclopedia italiana, 1990.
- J. Besson. *Theatrum instrumentorum et machinarum [...] Cum Franc. Bernaldi figurarum declaratione demonstrativa*. Lugduni, apud Barth. Vincentium, 1578.
- Viktor Blasjo. The rectification of quadratures as a central foundational problem for the early Leibnizian calculus. *Historia Mathematica*, 39(4):405–431, November 2012.
- Raphael Bombelli. *L'algebra*. Giovanni Rossi (Bologna), 1579.
- Jonathan M. Borwein and Peter B. Borwein. *π and the AGM: A Study in Analytic Number Theory and Computational Complexity*. Wiley-Interscience, July 1998.
- Henk J. Bos. Differentials, higher-order differentials and the derivative in the Leibnizian calculus. *Archive for History of Exact Sciences*, 14:1–90, 1974.
- Henk J. Bos. On the representation of curves in Descartes' Géométrie. *Archive for the History of Exact Sciences*, 24:295–338, 1981.
- Henk J. Bos. Arguments on Motivation in the Rise and Decline of a Mathematical Theory; the "Construction of Equations", 1637 - ca 1750. *Archive for the History of Exact Sciences*, 30:331–380, 1984.
- Henk J. Bos. Tractional motion and the legitimation of transcendental curves. *Centaurus*, 31:9–32, 1988.
- Henk J. Bos. The Structure of Descartes' Géométrie. In *Descartes, il metodo e i saggi*. Istituto della enciclopedia italiana, 1990.
- Henk J. Bos. *Redefining Geometrical Exactness*. Springer-Verlag, New York, Berlin, Heidelberg, 2001.

- A. Bowen. Maenechmus versus the Platonists: two Theories of Science in the early Academy. *Ancient Philosophy*, 3:12–29, 1983.
- C. B. Boyer. *History of analytic geometry*. Scripta mathematica, 1956.
- Carl B. Boyer. *The History of the Calculus and Its Conceptual Development*. Dover Publications, June 1959.
- Carl B. Boyer and Uta C. Merzbach. *A history of mathematics*. Wiley, New York, 1991.
- Hebert Breger. Leibniz' Einführung des Transzendenten. *Studia Leibnitiana*, 14:119–132, 1986.
- Herbert Breger. Der mechanistische Denkstil in der Mathematik des 17. Jahrhunderts. In *Gottfried Wilhelm Leibniz im philosophische Diskurs über Geometrie und Erfahrung* (H. Hecht editor). Akademie-Verlag, 1991.
- A. Brigaglia and Nastasi P. Le ricostruzioni Apolloniane in Viète e in Ghetaldi. *Bollettino di storia delle scienze matematiche*, VI, fasc. 1:83–133, 1986.
- Aldo Brigaglia. La riscoperta dell'analisi e i problemi apolloniani. In *Geometria, flussioni e differenziali*. La città del sole, 1995.
- Stephen Buckley and Desmond Machale. Dividing an angle into equal parts. *The Mathematical Gazette*, Vol. 69, No. 447:pp. 9–12, 1985.
- R.P. Burn. Alphonse Antonio de Sarasa and Logarithms. *Historia Mathematica*, 28(1): 1–17, February 2001.
- Walter A. Carnielli, Marcelo E. Coniglio, and Itala M. L. D'Ottaviano. New Dimensions on Translations Between Logics. *Logica Universalis*, 3(1):1–18, April 2009.
- J. M. Child. *The early mathematical manuscripts of Leibniz*. The Open Court Publishing Company, 1920.
- Lindsay N. Childs. *A Concrete Introduction to Higher Algebra*. Springer, New York, 3rd edition edition, December 2008.
- O. Chisini. Aree, lunghezze e volumi nella Geometria elementare. In *Questioni riguardanti le matematiche elementari*. Zanichelli, 1912.
- Marshall Clagett. *Archimedes in the Middle Ages. Vol 1: The Arabo-Latin Tradition*. The University of Wisconsin Press, first edition edition edition, 1964.

- Marshall Clagett. *Archimedes in the Middle Ages. Five Volumes*. American Philosophical Society, 1964-1984.
- C. Clavius. *Christophori Clavii Bambergensise Societate Iesv Geometria Practica*. eg Typographeo IOANNIS Albini., 1604.
- Federicus Commandinus. *Pappi Alexandrini mathematicae collectiones a Federico Commandino Urbinate in latinum conversae at commentariis illustratae*. Pesaro, Pisauri, 1588.
- J. L. Coolidge. *A History of Geometrical Methods*. Clarendon Press, Oxford, 1940.
- J. L. Coolidge. The Number e . *The American Mathematical Monthly*, 57(9):591, November 1950.
- Leo Corry. Linearity and Reflexivity in the Growth of Mathematical Knowledge. *Science in Context*, 3(02):409–440, September 2008.
- P. Costabel. Leibniz et les séries numériques. In *Leibniz à Paris (1672-76)*. Wiesband-Steiner and Verlag, 1978.
- Pierre Costabel. Descartes et les Mathématiques de l'Infini. *Historia Scientiarum*, 29: 37–49, 1985.
- Richard Courant and Herbert Robbins. *What is mathematics? An elementary approach to ideas and methods*. Oxford University Press, New York, 1996.
- L. Couturat. *Opuscles et fragments inédits: extraits des manuscrits de la Bibliothèque Royale de Hanovre par Louis Couturat*. Alcan, Paris, 1903.
- H. S. M. Coxeter and Samuel L. Greitzer. *Geometry Revisited*. MAA, September 1996.
- S Cuomo. *Pappus of Alexandria and the mathematics of late antiquity*. Cambridge University Press, Cambridge, 2007.
- Blank David. Ammonius. In *The Stanford Encyclopedia of Philosophy*. <http://plato.stanford.edu/archives/win2012/entries/ammonius/>, 2012.
- V. de Risi. *Geometry and Monadology: Leibniz's Analysis Situs and Philosophy of Space*. Science Networks. Historical Studies. Springer, 2007.
- Valérie Debuiche. L'expression leibnizienne et ses modèles mathématiques. *Journal of the History of Philosophy*, 51(3):409–439, 2013.

- M. Dehn and DE Hellinger. Certain mathematical achievements of James Gregory. *The American Mathematical Monthly*, 50(3):149–163, 1943.
- Guidobaldo Del Monte. *Mechanicorum Libri*. Hieronymum Concordiam, 1577.
- R. Descartes. *Renati Descartes Geometria*. F. Knoch, 1695.
- René Descartes. *Geometria, à Renato des Cartes anno 1637 Gallice edita: postea autem una cum notis Florimondi de Beaune, ... in linguam latinam versa et commentariis illustrata opera atque studio Francisci à Schooten*. apud Ludovicum et Danielem Elzevirios, Amstelaedami, 1659-1661.
- René Descartes. *R. Des-Cartes Opuscula posthuma physica et mathematica*. apud Janssonio-Waesbergios, Boom et Goethals (Amstelodami), 1701.
- René Descartes. *Oeuvres inédites de Descartes, précédées d'une introduction sur la Méthode*. A. Durand, 1859.
- René Descartes. *Oeuvres de Descartes, 12 vol.* Paris Cerf, Paris, 1897-1913.
- René Descartes. *The Geometry of René Descartes*, ed. D. E. Smith and M. L. Latham. Open Court, La Salle, 1952.
- René Descartes. *Oeuvres Complètes. III. Discours de la Méthode et Essais*. Gallimard, Paris, 2009.
- Michael Detlefsen. Formalism. In Stewart Shapiro, editor, *The Oxford handbook of Philosophy of Mathematics and Logic*. Oxford University Press, 2005.
- E. J. Dijksterhuis. James Gregory and Christiaan Huygens. In *The James Gregory Tercentenary Memorial Volume*. London, 1939.
- E. J. Dijksterhuis and Wilbur R. Knorr. *Archimedes, with a new bibliographic essay*. Princeton University Press, October 1987.
- Jacques Dutka. Wallis's product, Brouncker's continued fraction, and Leibniz's series. *Archive for History of Exact Sciences*, 26(2):115–126, 1982.
- C.H.Jr. Edwards. *The Historical Development of the Calculus*. Springer, June 1994.
- Federigo Enriques. *Questioni riguardanti le matematiche elementari*. N. Zanichelli, 1912.
- Euclid. *Euclidis elementorum lib. XV*. Rome, 1589.

- Euclid. *Les Eléments, traduction, commentaires et notes de Bernard Vitrac*. Presses Universitaires de France (PUF), December 1990.
- Euclid. *Dedomena: Euclid's Data, or The importance of being given*. Museum Tusulanum Press, Copenhagen, 2003.
- Euclide. *Tutte le opere: testo greco a fronte*. Bompiani, Milano, 2007.
- Pierre de Fermat. *Oeuvres de Fermat / publiées par les soins de MM. Paul Tannery et Charles Henry sous les auspices du Ministère de l'instruction publique*. Gauthier-Villars, 1891-1896.
- G. Ferraro. *The rise and development of the theory of series up to the early 1820s*. Springer Verlag, 2008.
- G. Ferraro and M. Panza. Developing into series and returning from series: A note on the foundations of eighteenth-century analysis. *Historia mathematica*, 30(1):17–46, 2003.
- Giovanni Ferraro and Marco Panza. Lagrange's theory of analytical functions and his ideal of purity of method. *Archive for History of Exact Sciences*, 66(2):95–197, December 2011.
- J. V. Field. The relation between geometry and algebra: Cardano and Kepler on the regular heptagon. In E. Kessler, editor, *Girolamo Cardano: Philosoph, Naturforscher, Artz*. Wiesbaden: Harrassowitz Verlag, 1994.
- P. Freguglia. Sul principio di omogeneità dimensionale tra Cinquecento e Seicento. *Boll. Unione Mat. Ital. B.*, 8:143–160, 1999a.
- Paolo Freguglia. *La geometria fra tradizione e innovazione: temi e metodi geometrici nell'eta della rivoluzione scientifica, 1550-1650*. Bollati Boringhieri, 1999b.
- H. Freudenthal. What is Algebra and What has it been in History? *Archive for history of exact sciences*, 16(3):189–200, 1977.
- Rudolf Fritsch. The transcendence of π has been known for about a century-but who was the man who discovered it? *Results in Mathematics*, 7:164–184, 1984.
- Galileo Galilei. *Opere*. UTET, 2005.

- M. Galuzzi and D. Rovelli. Storia della geometria e didattica: qualche osservazione. In *L'insegnamento della Geometria*. Quaderni Ministero della pubblica istruzione, 1996.
- Massimo Galuzzi. Newton attempt to construct a unitary view of mathematics. *Historia Mathematica*, 37:552–562, 2010.
- J.-L. Gardies. *Le raisonnement par l'absurde*. Puf, 1991.
- A.C. Garibaldi. Il problema della quadratrice nella matematica dei Gesuiti da Clavius alla metà del secolo XVII. In *Cristoph Clavius e l'attività scientifica dei Gesuiti nell'eta di Galileo*. Bulzoni, Chieti, 1996.
- S. Gaukroger. The nature of abstract reasoning: philosophical aspects of Descartes' work in algebra. In *The Cambridge companion to Descartes*. Cambridge University press, 1992a.
- Stephen Gaukroger. Descartes's Early Doctrine of Clear and Distinct Ideas. *Journal of the History of Ideas*, 53(4):585, October 1992b.
- C.F. Gauss. *Disquisitiones mathematicae*. Braunschweig, 1801.
- E. Giusti. La Geometrie e i matematici contemporanei. In Vinti C. Armogathe J.-R., Belgioioso G., editor, *La biografia intellettuale di René Descartes attraverso la Correspondance*. Vivarium, Napoli, 1999.
- Enrico Giusti. *Bonaventura Cavalieri and the Theory of Indivisibles*. Ed. Cremonese, 1980.
- Enrico Giusti. le problème des tangentes de Descartes à Newton. *Studia Leibnitiana*, 14: 26–37, 1986.
- Catherine Goldstein. L'arithmétique de Pierre Fermat dans le contexte de la correspondance de Mersenne : une approche microsociale. *Annales de la faculté des sciences de Toulouse*, 6, 18 S2:p. 25–57, 2009.
- Catherine Goldstein. Routine controverses : Mathematical challenges in Mersenne's correspondence. *Revue d'histoire des sciences*, 66(2):249, 2013.
- G. G. Granger. Philosophie et mathématique leibniziennes. *Revue de métaphysique et de morale*, 86:1:1–37, 1981.

- J. Gregory. *Exercitationes geometricae*. Giulielmi Godbid, 1668a.
- J. Gregory. *Geometriae pars universalis inserviens quantitatum curvarum transmutationi et mensurae*. Frambotti, 1668b.
- James Gregory. *Vera circuli et hyperbolae quadratura in propria sua proportionis specie, inuenta, & demonstrata*. ex typographia Iacobii de Cadorinis, Patavii, 1667.
- James Gregory. *The James Gregory Tercentenary Memorial Volume*. London, 1939.
- J. A. Grootendorst A. W., van Maanen. Van Heuraet's letter (1659) on the rectification of curves. Text, translation (English, Dutch), commentary. *Nieuw Archief voor Wiskunde*, 30:95–113, 1982.
- Emily Grosholz. Descartes' unification of algebra and geometry. In S. Gaukroger, editor, *Descartes: Philosophy, Mathematics and Physics*. Brighton, Harvester Press, 1980.
- Niccolo' Guicciardini. *Isaac Newton on Mathematical Certainty and Method*. MIT Press, Cambridge, Mass., 2009.
- M Guisnée. *Applications de l'algebre a la Geometrie, ou Methode de demonstrier par l'Algebre, les Theorèmes de Geometrie, et d'en resoudre et construire tous les Problèmes*. Paris, chez Quillau, 1733.
- Behnke H., Bachmann F., Fladt K., and Kunle H., editors. *Fundamentals of mathematics - Volume II- Geometry*. Mit Press, 1974.
- Robin Hartshorne. *Geometry: Euclid and Beyond*. Springer-Verlag, New York, Berlin, Heidelberg, 2000.
- T. Heath. *Apollonius of Perga treatise on conic sections (edited in modern notation)*. Cambridge University press, 1896.
- T. Heath. *Thirteen books of Euclid's Elements (volume 1)*. Dover, 1956 (first edition 1908)a.
- T. Heath. *Thirteen books of Euclid's Elements (volume 2)*. Dover, 1956 (first edition 1908)b.
- Thomas Heath. *The Works of Archimedes*. Cambridge University Press, 1897.
- Thomas Heath. *A History of Greek Mathematics, Vol. 1: From Thales to Euclid*. Dover Publications, May 1981.

- Thomas Heath. *Mathematics in Aristotle*. St. Augustine's Press, August 1998.
- Hartmut Hecht, Regina Mikosch, Ingo Schwarz, Harald Siebert, and Romy Werther. *Kosmos und Zahl: Beiträge zur Mathematik- und Astronomiegeschichte, zu Alexander von Humboldt und Leibniz*. Steiner (Franz), 1 edition, December 2008.
- H.J. Hess. Bücher aus dem Besitz von Christiaan Huygens (1629-1695) in der Niedersächsischen Landesbibliothek Hannover. *Studia Leibnitiana*, 12(1):1–51, 1980.
- H.J. Hess. Maturing in Retirement. The unknown period of the Leibnizian Calculus between Paris and publication (1676-1684). In *Giornate di Storia della Matematica, Cetraro (Cosenza)*, 1991.
- D. Hilbert. Mathematische Probleme. *Archiv für Mathematik und Physik*, 3, 1:44–63, 213–237, 1901.
- D. Hilbert. *David Hilbert's Lectures on the Foundations of Geometry, 1891-1902*. Springer-Verlag, Berlin Heidelberg New York, 2000a.
- David Hilbert. Mathematical Problems. *Bulletin of the American Mathematical Society*, 37, 4:407–436, 2000b.
- Jaakko Hintikka. Method of Analysis: A Paradigm of Mathematical Reasoning? *History and Philosophy of Logic*, 33(1):49–67, February 2012.
- Jaakko Hintikka and Unto Remes. *The method of analysis: its geometrical origin and its general significance*. Springer, 1974.
- J. E. Hofmann. Die Quellen der cusanischen Mathematik I: Ramon Lulls Kreisquadratur. *Sitzungsberichte der Heidelberger Akademie der Wissenschaften Philosophisch-historische Klasse*, 4:1–38, 1941/42.
- J.E. Hofmann. François Viète und die Archimedische Spirale. *Archiv der Mathematik*, 5 (1):138–147, 1954.
- Joseph H. Hofmann. *Leibniz in Paris 1672-1676: His Growth to Mathematical Maturity*. Cambridge University Press, September 2008.
- J. Hogendijk. Greek and Arabic constructions of the regular heptagon. *Archive for History of Exact Sciences*, 30, issue 3-4:197–330, 1984.
- J. Hogendijk. Desargues' 'Brouillon Projet' and the Conics of Apollonius. *Centaurus*, 34:1–43, 1991.

- J. Hogendijk. Four constructions of two mean proportionals between two given lines in the Book of Perfection Istikmal of Al Mu'taman Ibn Hud. *Journal for the History of Arabic Science*, 10:13–29, 1992.
- Jan Hogendijk. The scholar and the fencing master: The exchanges between Joseph Justus Scaliger and Ludolph van Ceulen on the circle quadrature (1594-1596). *Historia Mathematica*, 37(3):345–375, 2010.
- Geoffrey Hunter. *Metalogic: An Introduction to the Metatheory of Standard First Order Logic*. University of California Press, 1973.
- Christiaan Huygens. *Oeuvres complètes publiées par la Société hollandaise des sciences. 22 vol.* The Hague, M. Nijhoff, 1888-1950.
- Jens Høyrup. Serafina Cuomo, Pappus of Alexandria and the Mathematics of Late Antiquity. Cambridge (Cambridge Classical Studies, Cambridge University Press) 2000. pp. ix + 234, including 22 pp. bibliography, 4 pp. general index and 7 pp. index locorum. *British Journal for the History of Science*, 34:240–242, 2001.
- Marie Jacob. *La quadrature du cercle : Un problème à la mesure des Lumières*. Fayard, May 2005.
- Douglas M. Jesseph. *Squaring the Circle. The war between Hobbes and Wallis*. The University of Chicago Press, Chicago, 1999.
- Vincent Jullien. *Descartes, la "Géométrie" de 1637*. Presses Universitaires de France - PUF, puf edition, 1996.
- Vincent Jullien. Les Frontières dans les Mathématiques Cartésiennes. *Historia Scientiarum*, 8, n. 3, 1999.
- Vincent Jullien. *Philosophie naturelle et géométrie au XVIIe siècle*. Champion, 2006.
- A. B. Kempe. *How to Draw a Straight Line*. Macmillan and Co., 1877.
- A.B. Kempe. On a general method of describing plane curves of the nth degree by linkwork. *Proceedings of the London mathematical society*, 7:213–216, 1876.
- Philip Kitcher. *The Nature of Mathematical Knowledge*. Oxford University Press, New York, Oxford, 1984.
- F. C. Klein. *The Evanston Colloquium. Lectures on Mathematics*. Macmillan and Co., 1894.

- Felix. C. Klein. *Vorträge über ausgewählte Fragen der Elementargeometrie*. Teubner, Leipzig, 1895.
- E. Knobloch. Leibniz and Euler: problems and solutions concerning infinitesimal geometry and calculus. In *Giornate di storia della matematica (Cetraro)*, 1988.
- E. Knobloch. Leibniz et son manuscrit inédit sur la quadrature des sections coniques. In *The Leibniz Renaissance, International Workshop (Florence 2-5, 1986)*, 1989.
- E. Knobloch. Galileo and Leibniz: Different approaches to infinity. *Archive for history of exact sciences*, 54(2):87–99, 1999a.
- E. Knobloch. Leibniz's rigorous foundation of infinitesimal geometry by means of Riemannian sums. *Synthese*, 133(1):59–73, 2002.
- E. Knobloch. Generality and Infinitely Small Quantities in Leibniz's Mathematics: The Case of his Quadrature of Conic Sections and Related Curves. In *Infinitesimal Differences: Controversies between Leibniz and his Contemporaries*. W. de Gruyter, 2008.
- Eberhard Knobloch. Im freiesten Streifzug des Geistes (Liberrimo mentis discursu): Zu den Zielen und Methoden Leibnizscher Mathematik. In Kurt, editor, *Wissenschaft und Weltgestaltung: Internationales Symposium zum 350. Geburtstag von Gottfried Wilhelm Leibniz*, pages 211–229. Olms, 1999b.
- Eberhard Knobloch. Beyond Cartesian limits: Leibniz's passage from algebraic to transcendental mathematics. *Historia Mathematica*, 33:113–131, 2006.
- W. R. Knorr. Archimedes' Neusis-Constructions in Spiral Lines. *Centaurus*, 22(2):77–98, 1978.
- W. R. Knorr. Construction as Existence Proof in Ancient Geometry:. *Ancient Philosophy*, 3(2):125–148, 1983.
- Wilbur R. Knorr. *The Ancient Tradition of Geometric Problem Solving*. Birkhauser, Boston, 1986.
- Wilbur Richard Knorr. *Textual Studies in Ancient and Medieval Geometry*. Springer, 1989.
- Walter Roy Laird and Sophie Roux. *Mechanics and Natural Philosophy before the Scientific Revolution*. Springer, January 2008.

- Detlef Laugwitz. Eine elementare Methode für Unmöglichkeitbeweise bei Konstruktionen mit Zirkel und Lineal. *Elemente der Mathematik*, 17:54–58, 1962.
- G. W. Leibniz. De Vera Proportione Circuli ad Quadratum in Numeris Rationalibus Expressa. *Acta Eruditorum*, 1:41–46, 1682.
- G. W. Leibniz. De geometria recondita et analysi indivisibilium atque infinitorum. *Acta Eruditorum*, 1686.
- G. W. Leibniz. *Mathematische Schriften. Vol. III (LSG3)*. Berlin, 1849-63a.
- G. W. Leibniz. *Mathematische Schriften, vol. V (LSG5)*. Berlin, 1849-63b.
- G. W. Leibniz. *Sämtliche Schriften und Briefe Zweite Reihe: Philosophischer Briefwechsel Bd. 1: 1663-1685 (AIII)*. Akademie-Verlag, 1926.
- G. W. Leibniz. *Sämtliche Schriften und Briefe Sechste Reihe: Philosophische Schriften Bd. 2: 1663-1672 (AVI, 2)*. Akademie-Verlag, 1966.
- G. W. Leibniz. *Sämtliche Schriften und Briefe. Dritte Reihe: Mathematischer, naturwissenschaftlicher und technischer Briefwechsel. Bd. 1, 1672-1676 (AIII, 1)*. Akademie-Verlag, 1976.
- G. W. Leibniz. *La naissance du calcul différentiel. Introduction, traductions et notes par Marc Parmentier*. Vrin, 1989.
- G. W. Leibniz. *Sämtliche Schriften und Briefe Siebente Reihe: Mathematische Schriften, Bd. 1: 1672-1676. Geometrie - Zahlentheorie - Algebra (AVIII)*. Akademie-Verlag, 1990.
- G. W. Leibniz. *Sämtliche Schriften und Briefe. Dritte Reihe: Mathematischer, naturwissenschaftlicher und technischer Briefwechsel. Bd. 2, 1676-1679 (AIII,2)*. Akademie-Verlag, 1995a.
- G. W. Leibniz. *Sämtliche Schriften und Briefe. Dritte Reihe: Mathematischer, naturwissenschaftlicher und technischer Briefwechsel. Bd. 3, 1680-1683 (AIII3)*. Akademie-Verlag, 1995b.
- G. W. Leibniz. *Sämtliche Schriften und Briefe. Dritte Reihe: Mathematischer, naturwissenschaftlicher und technischer Briefwechsel. Bd. 4, 1684-1687 (AIII,4)*. Akademie-Verlag, 1995c.

- G. W. Leibniz. *The labyrinth of the continuum. Writings on the continuum problem (1672-1686)*. Yale University Press, 2001.
- G. W. Leibniz. *Sämtliche Schriften und Briefe. Siebente Reihe: Mathematische Schriften. Band 3, 1672-1676. Differenzen, Folgen, Reihen (AVII, 3)*. Akademie-Verlag, 2003.
- G. W. Leibniz. *Quadrature arithmétique du cercle, de l'ellipse et de l'hyperbole et la trigonométrie sans tables qui en est le corollaire*. Vrin, 2004.
- G. W. Leibniz. *Sämtliche Schriften und Briefe Siebente Reihe: Mathematische Schriften. Bd. 4: 1670-1673. Infinitesimalmathematik (AVII, 4)*. Akademie-Verlag, 2008a.
- G. W. Leibniz. *Sämtliche Schriften und Briefe Siebente Reihe: Mathematische Schriften, Bd. 5: 1674-1676. Infinitesimalmathematik (AVII, 5)*. Akademie-Verlag, 2008b.
- G. W. Leibniz. *Gottfried Wilhelm Leibniz: Die mathematischen Zeitschriftenartikel (Mit einer CD: Die originalsprachlichen Fassungen)*. Olms, 2011.
- G. W. Leibniz. *Sämtliche Schriften und Briefe Siebente Reihe: Mathematische Schriften, Bd. 7: 1673-1676. Arithmetische Kreisquadratur (AVII6)*. Akademie-Verlag, 2012.
- Samuel Levey. Leibniz on Mathematics and the Actually Infinite Division of Matter. *The Philosophical Review*, 107(1):49–96, 1998.
- F. Lindemann. Ueber die Zahl π . *Mathematische Annalen*, 20(2):213–225, June 1882.
- G. Loria. *Curve piane speciali, algebriche e trascendenti*. Hoepli, 1930.
- J. Lützen. *Joseph Liouville 1809-1882. Master of Pure and Applied Mathematics*. Springer, 1990.
- Jesper Lützen. Why was Wantzel overlooked for a century? The changing Importance of an Impossibility Result. *Historia Mathematica*, 36:pp. 374–394, 2009.
- Jesper Lützen. The Algebra of Geometric Impossibilities: Descartes and Montucla on the Impossibility of the Duplication of the Cube and the Trisection of the Angle. *Centaurus*, 52:4–37, 2010.
- Danielle Macbeth. Viète, Descartes, and the emergence of modern mathematics. *Graduate Faculty philosophy journal*, 25:87–118, 2004.

- Petri Maenpaa. From backward reduction to configurational analysis. In Michael Otte and Marco Panza, editors, *Analysis and synthesis in mathematics: history and philosophy*. Springer, 1997.
- Dietrich Mahnke. Neue Einblicke in die Entdeckungsgeschichte der höheren Analyse. *Abhandlungen der Preussische Akademie der Wissenschaften*, Phys-math Klass, 1: 1–71, 1925.
- M. Mahoney. The beginnings of algebraic thought in the seventeenth century. In *Descartes: philosophy, mathematics and physics*. The Harvester Press, 1980.
- Michael Mahoney. *The Mathematical Career of Pierre de Fermat*. Princeton University Press, Princeton, New Jersey, 1973.
- M.S. Mahoney. Changing canons of mathematical and physical intelligibility in the later 17th century. *Historia Mathematica*, 11(4):417–423, 1984.
- A. Malet. *Studies on James Gregorie*. PhD thesis, Princeton University, 1989.
- Antoni Malet. *From Indivisibles to Infinitesimals: Studies on Seventeenth-Century Mathematizations of Infinitely Small Quantities*. Universitat Autònoma de Barcelona, 1996.
- Paolo Mancosu. *Philosophy of Mathematics and Mathematical Practice in XVII Century*. Oxford University Press, 1999.
- Paolo Mancosu. Descartes and mathematics. In John Carriero Janet Broughton, editor, *A Companion to Descartes*. Blackwell, 2007.
- Paolo Mancosu. *The philosophy of mathematical practice*. Oxford University Press, Oxford; New York, 2011.
- Paolo Mancosu and Andrew Arana. Descartes and the cylindrical helix. *Historia Mathematica*, 37(3):403–427, 2010. Contexts, emergence and issues of Cartesian geometry: In honour of Henk Bos's 70th birthday.
- Kenneth Manders. Algebra in Roth, Faulhaber, and Descartes. *Historia Mathematica*, 33:184–209, 2006.
- Jaap Mansfeld. *Prolegomena Mathematica: From Apollonius of Perga to Late Neoplatonism : With an Appendix on Pappus and the History of Platonism*. Brill, 1998.

- S. Maronne. *La théorie des courbes et des équations dans la Géométrie cartésienne : 1637-1661*. PhD thesis, Université Paris 7-Denis Diderot, 2007.
- Sébastien Maronne. The ovals in the Excerpta Mathematica and the origins of Descartes' method of normals. *Historia Mathematica*, 37(3):460–484, August 2010.
- Henry Mendell. Aristotle and Mathematics. In Edward N. Zalta, editor, *The Stanford Encyclopedia of Philosophy*. <http://plato.stanford.edu/archives/win2008/entries/aristotle-mathematics/>, winter 2008 edition, 2008.
- N. Mercator. *Logarithmotechnia, sive methodus construendi logarithmos nova, accurata et facilis*. Guilielmi Godbid, 1668.
- M. Mersenne. *Harmonie Universelle contenant la théorie de la pratique de la musique*. Paris, 1636.
- Marin Mersenne. *Correspondance du P. Marin Mersenne: religieux minime*. Editions du Centre national de la recherche scientifique, 1986.
- Sabetai Unguru Michael N. Fried. *Apollonius of Pergas' Conica. Text, Context, Subtext*. Brill, Leiden, Boston, Köln, 2001.
- Edwin E Moise. *Elementary geometry from an advanced standpoint*. Addison-Wesley, Reading, Mass., 1990.
- A. G. Molland. Shifting the Foundations: Descartes' Transformation of Ancient Geometry. *Historia Mathematica*, 3:21–49, 1976.
- A. G. Molland. Implicit versus explicit geometrical methodologies. In *Mathématiques et philosophie de l'antiquité à l'âge classique*. Paris, 1991.
- J. E. Montucla. *Histoire des recherches sur la quadrature du cercle: avec une addition concernant les problèmes de la duplication du cube et de la trisection de l'angle*. Paris: Jombert, 1754.
- Jean Etienne Montucla. *Histoire des recherches sur la quadrature du cercle*. Bachelier père et fils, 1831.
- I. Mueller. Aristotle and the Quarature of the Circle. In *Infinity and continuity in ancient and medieval thought*. Cornell University Press, 1982.

- Ian Mueller. *Philosophy of Mathematics and Deductive Structure in Euclid's Elements*. Dover Publications, November 2006.
- P. Mäenpää. *The Art of Analysis: Logic and History of Problem Solving*. PhD thesis, University of Helsinki, 1993.
- Isaac Newton. *Arithmetica universalis, sive de compositione et resolutione arithmetica*. Amsterdam, 1745.
- M. Otte. Does mathematics have objects? In what sense? *Synthese*, 134(1):181–216, 2003.
- Michael Otte and Marco Panza. *Analysis and synthesis in mathematics: history and philosophy*. Springer, 1997.
- J. Ozanam. *Dictionnaire mathématique ou idée générale des mathématiques*. Amsterdam, Huguetan, 1691.
- M. Panza. François Viète: between analysis and cryptanalysis. *Studies in History and Philosophy of Science Part A*, 37(2):269–289, June 2006.
- M. Panza. What is new and what is old in Viète's analysis restituta and algebra nova, and where do they come from? Some reflections on the relations between algebra and analysis before Viète. *Revue d'Histoire des Mathématiques*, 13:83–153, 2007.
- M. Panza. Rethinking Geometrical Exactness. *Historia Mathematica*, 38:42–95, 2011.
- Marco Panza. *Newton et les Origines de l'Analyse*. Editions Albert Blanchard, Paris, 2005.
- Marco Panza and Clara Silvia Roero. *Geometria, flussioni e differenziali*. La Città Del Sole, 1995.
- Pappus. *Collectionis quae supersung*. Berlin, Weidman, 1876-1878.
- Pappus. *Book 7 of the Collection*. Springer, 1986.
- Gaston Pardies. *Elements de Geometrie*. Chez Adrien Moetjens, marchand libraire pres la cours, Librairie française, 1671.
- Enrico Pasini. *Il reale e l'immaginario. La fondazione del calcolo infinitesimale nel pensiero di Leibniz*. Sonda, 1993.

- Poprhyry. *Introduction*. Oxford University Press, 2003.
- B. Pourciau. The integrability of ovals: Newton's Lemma 28 and its counterexamples. *Archive for history of exact sciences*, 55(5):479–499, 2001.
- S. Probst. Leibniz und Wallis (1672-1676). In *Mathematik im Fluss der Zeit*. Algorismus, 2004.
- S. Probst. Zur Datierung von Leibniz' Entdeckung der Kreisreihe. In *Einheit in der Vielheit. VIII. Internationaler Leibniz-Kongress*. Hannover: Gottfried-Wilhelm-Leibniz-Gesellschaft, 2006a.
- S. Probst. Differenzen, Folgen und Reihen bei Leibniz (1672-1676). In *Wanderschaft in der Mathematik*. Augsburg, 2006b.
- S. Probst. Neues über Leibniz' Abhandlung zur Kreisquadratur. In *Kosmos und Zahl*. Stuttgart: Franz Steiner Verlag, 2008a.
- S. Probst. Leibniz und die cartesische Geometrie (1673-1676). In S Fischer, H. Deschauer, editor, *Zeitläufte der Mathematik*, pages 149–158. Augsburg, 2012.
- Siegmund Probst. Indivisibles and Infinitesimals in Early Mathematical Texts of Leibniz. In *Infinitesimal differences: Controversies between Leibniz and his Contemporaries*. Walter de Gruyter, 2008b.
- Proclus. *Les commentaires sur le premier livres des Eléments d'Euclide*. Bruges, 1948.
- Proclus. *A Commentary on the First Book of Euclid's Elements*. Princeton University Press, 1992.
- D. Rabouin. What Descartes knew of mathematics in 1628. *Historia Mathematica*, 37: 428–459, 2010.
- Claude Rabuel. *Commentaires sur la Géométrie de M. Descartes*. Marcellin Duplain, Lyon, 1730.
- R. Rashed. Les premières classifications des courbes. *Physis, Rivista internazionale di storia della scienza*, XLII:1–64, 2005.
- Guglielmo Righini. Sulla costruzione del compasso geometrico e militare di Galileo. *Physis, Rivista internazionale di storia della scienza*, XVI,3:201–222, 1974.
- D. Rivault. *Archimedis Opera quae extant*. Paris, Claude Morel, 1615.

- James Robert. *Mathematics Dictionary (fifth edition)*. Chapman and Hall, 1992.
- A. Romano. *La Contre-Réforme mathématique*. Ecole française de Rome, 2000.
- T. Roque. *História da matemática*. Zahar, November 2012.
- K. Saito. Doubling the cube: a new interpretation and its significance for early modern geometry. *Historia Mathematica*, 22:119–137, 1985.
- K. Saito and N. Sidoli. The function of diorism in ancient Greek analysis. *Historia Mathematica*, 37(4):579–614, 2010.
- C. Sasaki. *Descartes's mathematical thought*. Springer, 2003.
- J. A. Schuster. Descartes' Mathesis Universalis: 1619-28. In *Descartes: Philosophy, Mathematics and Physics*. Harvester Press, 1980.
- C. J. Scriba. *James Gregory's frühe Schriften zur Infinitesimalrechnung*. Selbstverlag des Mathematischen Seminars, 1957.
- C. J. Scriba. The inverse method of tangents: A dialogue between Leibniz and Newton (1675-1677). *Archive for history of exact sciences*, 2(2):113–137, 1963.
- C. J. Scriba. Gregory's converging double Sequence. A New look at the controversy between Huygens and Gregory over the "analytica" Quadrature of the circle. *Historia Mathematica*, 10:274–285, 1983.
- H. Sefrin-Weis. *Pappus of Alexandria. Book IV of The Collection*. Springer-Verlag, 2010.
- M. Serfati. Les compas cartésiens. *Archives de philosophie*, 56-2, 1993.
- M. Serfati. Le développement de la pensée mathématique du jeune Descartes. In *De la méthode*. PUC, 2002.
- M. Serfati and M. Bitbol. *De la méthode: recherches en histoire et philosophie des mathématiques*. Presses Univ. Franche-Comté, 2002.
- L. Shabel. *Mathematics in Kant's critical philosophy. Studies in philosophy: outstanding dissertation series*. Routledge, 2003.
- C. Smorynski. *History of Mathematics: A Supplement*. Springer, 1 edition, December 2007.

- J. A. Stedall. *A Discourse Concerning Algebra: English Algebra to 1685*. Oxford University Press, 2002.
- Jacqueline A. Stedall. *From Cardano's Great Art to Lagrange's Reflections: Filling a Gap in the History of Algebra*. European Mathematical Society, January 2011.
- Daniel Steele. Über die Rolle von Zirkel und Lineal in der Griechischen Mathematik. *Quellen und Studien zur Geschichte der Mathematik*, 3:288–369, 1936.
- S. Stevin. *The Principal Works of Simon Stevin*. Amsterdam, 1958.
- I. Stewart. *Galois Theory. Third Edition*. Chapman and Hall/CRC, London, 2003.
- Edmund Stone. *The construction and principal use of mathematical instruments, translated from the French, of M. Bion, Chief Instrument-Maker to the French King*. London, 1723.
- P. Stromholm. Fermat's methods of maxima and minima and of tangents. A reconstruction. *Archive for History of Exact Sciences*, 1:47–69, 1969.
- A. Szabó. *The Beginnings of Greek Mathematics*. Springer, November 1978.
- H. K. Sørensen. *The mathematics of Niels Henrik Abel*. PhD thesis, History of Science Department, University of Aarhus, 2004.
- H. K. Sørensen. Representations as Means and Ends: Representability and Habituation in Mathematical Analysis During the First Part of the Nineteenth Century. In *New perspectives on mathematical practice*, 2009.
- P. Tannery. Pour l'histoire des lignes et surfaces courbes dans l'Antiquité. *Bulletin des sciences mathématiques et astronomiques, 2 série*, tome 7, n.1:278–291, 1883.
- F. G. Teixeira. *Traité des courbes spéciales remarquables planes et gauches*. Paris Gabay, 1995.
- E. Torricelli. *Opere di Evangelista Torricelli, edite da Gino Loria e Giuseppe Vassura. Tomo III*. Fenza, G. Montanari, 1919.
- A. P. Treewek. Pappus of Alexandria The manuscript tradition of the "Collectio Mathematica". *Scriptorium*, 11:195–233, 1957.
- J. Tropfke. *Geschichte der Elementar-Mathematik in systematischer Darstellung*. Leipzig, Verlag von Veit, 1902.

- E. Ulivi. Il tracciamento delle curve prima di Descartes. In *Descartes: il metodo e i saggi. Atti del convegno per il 350 anniversario della pubblicazione del Discours de la méthode e degli Essays*. Istituto della enciclopedia italiana, 1990.
- S. Unguru. On the Need of Rewriting the History of Mathematics. *Archives for History of Exact Sciences*, 15, n. 1:67–114, 1975.
- S. Unguru and M. Fried. The Three-and Four-Lines Locus in Apollonius's Conica: Geometry and Algebra. Conference Paper presented at the workshop: "mathematical understanding", Université Paris 7, 9-13 June 2008.
- Bartel L. Van der Waerden. *Science awakening (english translation by Arnold Dresden)*. Oxford University Press, 1961.
- Philippus van Lansbergen. *Triangulorum geometriae libri quatuor. Cyclometriae novae libri duo*. Middelburg, 1616.
- J. van Maanen. Review Symposium: John Pell (1611-1685): Mathematical Utopian. *Metascience*, 15:217–249, 2006.
- Jan A. van Maanen. Hendrick van Heuraet (1634-1660?): His Life and Mathematical Work. *Centaurus*, vol. 27, n. 3-4:218–279, 1984.
- F. van Schooten. *Exercitationum mathematicarum libri quinque*. Lugd. Batav. : ex officina Johannis Elsevirii, 1656-57.
- F. Viète. *Variorum de rebus mathematicis responsorum liber VIII*. Mettayer, 1593.
- F. Viète. *The Analytic Art: Nine Studies in Algebra, Geometry and Trigonometry from the Opus restitutae Mathematicae Analyseos, seu Algebrâ Novâ*. Dover, Mineola, New York, 1983.
- François Viète. *Francisci Vietae opera mathematica*. Lugd. Batav. : ex officina Johannis Elsevirii, 1646.
- Jules Vuillemin. *Mathématiques et métaphysique chez Descartes*. Presses universitaires de France, 1987.
- J. Wallis. Philosophical Transactions of the Royal Society: An account of two books. *Philosophical Transactions of the Royal Society*, 3:640–644, 1668a.
- J. Wallis. An Account of Two Books-Logarithmotechnia Nicolai Mercatoris. *Philosophical Transactions of the Royal Society of London*, 3(33-44):750–764, January 1668b.

- J. Wallis. An extract from a letter of Dr. Wallis, of May 1697, concerning the cycloid known to Cardinal Cusanus, about the year 1450, and to Carolus Bovillus, about the year 1500. *Philosophical Transactions of the Royal Society*, 1:561–566, 1695.
- J. Wallis. *Opera mathematica (3 vols)*. Oxford, 1695, 1693, 1699.
- J. Wallis. *The Arithmetic of Infinitesimals: John Wallis 1656*. Springer, 1 edition, August 2004.
- J. Wallis. *Correspondence of John Wallis (1668-1671). Volume III*. Oxford University Press, Oxford, 2012.
- John Wallis. *The Correspondence of John Wallis (1616-1703): Volume II (1660 - September 1668)*. OUP Oxford, January 2005.
- Pierre L. Wantzel. Recherches sur les moyens de reconnaître si un Problème de Géométrie peut se résoudre avec la Règle et le Compas. *Journal des mathématiques pures et appliquées*, 2:366–372, 1837.
- Derek T. Whiteside. Patterns of mathematical thought in later 17th century mathematics. *Archive for the History of Exact Sciences*, 1:1–210, 1961.
- Joella G. Yoder. *Unrolling time: Christiaan Huygens and the mathematization of nature*. Cambridge University Press, 1988.
- H. G. Zeuthen. *Die Lehre von den Kegelschnitten im Altertum / von Dr. H. G. Zeuthen, ... ; Deutsche Ausgabe unter Mitwirkung des Verfassers besorgt von Dr. R. v. Fischer-Benzon*. A. F. Höst und Sohn (Kopenhagen), 1886.
- H. G. Zeuthen. Die geometrische Construction als Existenzbeweis in der antiken Geometrie. *Mathematische Annalen*, 47(2):222–228, 1896.