



HAL
open science

In-plane X-ray diffraction from monolayers of perfluorinated fatty acids: evidence for azimuthal ordering in the condensed phase

M. Goldmann, Pierre Nassoy, Francis Rondelez, Anne Renault, Seokmin Shin,
Stuart Rice

► **To cite this version:**

M. Goldmann, Pierre Nassoy, Francis Rondelez, Anne Renault, Seokmin Shin, et al.. In-plane X-ray diffraction from monolayers of perfluorinated fatty acids: evidence for azimuthal ordering in the condensed phase. *Journal de Physique II*, 1994, 4 (5), pp.773-785. 10.1051/jp2:1994164. jpa-00248000

HAL Id: jpa-00248000

<https://hal.science/jpa-00248000>

Submitted on 4 Feb 2008

HAL is a multi-disciplinary open access archive for the deposit and dissemination of scientific research documents, whether they are published or not. The documents may come from teaching and research institutions in France or abroad, or from public or private research centers.

L'archive ouverte pluridisciplinaire **HAL**, est destinée au dépôt et à la diffusion de documents scientifiques de niveau recherche, publiés ou non, émanant des établissements d'enseignement et de recherche français ou étrangers, des laboratoires publics ou privés.

Classification

Physics Abstracts

68.00 — 68.17 — 61.10F

In-plane X-ray diffraction from monolayers of perfluorinated fatty acids : evidence for azimuthal ordering in the condensed phase

Michel Goldmann ⁽¹⁾, Pierre Nassoy ⁽¹⁾, Francis Rondelez ⁽¹⁾, Anne Renault ⁽²⁾, Seokmin Shin ⁽³⁾ and Stuart A. Rice ⁽³⁾

⁽¹⁾ Laboratoire de Physico-Chimie des Surfaces et Interfaces, Institut Curie, 75231 Paris, France

⁽²⁾ Laboratoire de Spectrométrie Physique, Université Joseph Fourier, BP. 87, 38402 St Martin d'Hères, France

⁽³⁾ Department of Chemistry and The James Franck Institute, The University of Chicago, Chicago, IL 60637 U.S.A.

(Received 27 August 1993, revised 23 December 1993, accepted 9 February 1994)

Abstract. — We report the results of new grazing incidence X-ray diffraction studies of Langmuir monolayers of $F(CF_2)_{11}COOH$ and $F(CF_2)_{10}CH_2COOH$ supported on water ; in each case the locations and intensities of the first three diffraction peaks ((1, 0), (1, 1) and (2, 0)) have been measured. These new data are consistent with earlier ones in that both monolayers have simple hexagonal packing of molecules with their long axes nearly perpendicular to the water surface at maximum surface densities. By comparing the ratios of the intensities of the several diffraction peaks observed in each case, one can conclude that at least one of the molecules is not in a free rotator phase. These ratios are used, together with a fit to the Debye-Waller factor, to discriminate between different models of the azimuthal ordering in the monolayer. A model of close packed monolayer with freely rotating molecules is inconsistent with the integrated diffraction intensities for $F(CF_2)_{11}COOH$. Much better agreement is obtained when an orientational ordering of the long axes of the amphiphilic molecules is assumed in the monolayer. On the other hand, in the case of $F(CF_2)_{10}CH_2COOH$, either of the two models, free rotating or azimuthal ordering, appears to be equally consistent with the diffraction data.

1. Introduction.

The existence of crystalline order in a two-dimensional system has been a subject of controversy for many years. In principle, a true two-dimensional crystal, as characterized by infinitely long range translational order, cannot exist since in such a system this long-range order is destroyed by a phonon induced divergence of the mean square atomic displacement from a reference lattice site (Peierls theorem [1]). However, because this divergence is only logarithmic in the size of the system, a two-dimensional array of atoms can have crystalline order in domains of finite size and can generate resolution-limited diffraction peaks.

The ideal system for investigating the properties of ordered two-dimensional arrays is a free-standing atomic monolayer, i.e. one without any interactions in the directions perpendicular to the plane of the monolayer. Since such a system is purely hypothetical, other systems, e.g. smectic liquid crystal films and monolayers supported on solid substrates [2], have been used as surrogates. The drawback in using such surrogates is that, contrary to the free standing atomic layer, the structure of the substrate can induce ordering in the overlayer. For this reason a Langmuir film [3] consisting of self-assembled long chain amphiphiles supported on liquid water is likely to be a better approximation to the ideal monolayer. This inference follows from the observation that a liquid subphase has no effect on the long-range order of the deposited monolayer. Moreover, a Langmuir monolayer is known to exhibit many phases and mesophases, and transitions between these are readily observed. Of the many possible molecules forming Langmuir monolayers, long chain fatty acids supported on water have been of popular use [4] since their linear alkyl chain structure, with a COOH head group and a CH₃ terminal group, yields relatively simple intermolecular and intramolecular interactions. The phase diagram of such a monolayer displays, in different regions, a gas phase and several different condensed phases [5], some of which being probably hexatic phases [6].

At present there is still very little information available concerning long-range order in Langmuir monolayers and Langmuir-Blodgett films. For instance, Garoff *et al.* [7] have shown, using electron diffraction, that a Langmuir-Blodgett film of a long chain amphiphile can have orientational coherence over a spatial range of a few microns, suggesting the existence of a hexatic phase. However, the influence on the structure of the monolayer of the solid substrate, and of the forces that act during the transfer from the original liquid substrate to the solid substrate, are not known. Therefore the *in situ* fluorescence microscopy observations of McConnell *et al.* [8] on water-supported monolayers, showing that there can be long-range orientational order in a phase which does not have long-range positional order [9] are of great importance. Grazing incidence X-ray diffraction has also been used by several investigators [10] to study the microscopic structure of water-supported monolayers of long-chain amphiphile molecules. To date, the structures inferred have usually, but not always, been based on the measurement of the first order diffraction peaks (1, 0) and (0, 1), and on the assumption that the projected unit cell in the plane of the monolayer is hexagonal or centered rectangular (distorted hexagonal). The correlation length for translational ordering is difficult to measure accurately in these diffraction experiments. Generally, the peak widths are found to be resolution-limited, which only allows a minimum value of roughly 400 Å to be set for the correlation length. The last result should certainly not be taken as direct evidence for crystalline order in the classical sense, which requires a long-range lattice for the positions of the centres of mass plus a long-range correlation of azimuthal rotations around the chain molecular axis. The best approach is to make a comparison with the molecular packing in lamellar crystals of long chain alkanes. Within one lamella, the ordering is akin to that in a water-supported monolayer of long-chain amphiphiles. In addition to having an orthorhombic phase in which the planar backbones of the all trans chains are azimuthally ordered, the long-chain alkane crystals also have so called rotator phases at higher temperatures. In the rotator I phase the projection of the unit cell in two dimensions is pseudohexagonal and the azimuthal orientations of the molecules are correlated, whereas in the rotator II phase the projection of the unit cell in two dimensions is hexagonal and the azimuthal orientations are completely uncorrelated (random). Shih *et al.* have attempted to distinguish between azimuthally ordered and disordered rotator phases of a hydrocarbon monolayer by measuring the distortion of the hexagonal projection of the unit cell in the plane of the interface and/or the variation of the width of the diffraction peak [11]. However, if diffraction peak of high order can be detected, a more precise way of detecting azimuthal ordering is to compare the observed peak intensity distributions to the calculated structure factors of models of the monolayer with and without

this ordering. Unfortunately, for the systems studied by Shih *et al.* the data were insufficient to carry out such a structure factor analysis.

Perfluorinated amphiphiles have properties which are of value for the study of molecular packing in monolayers. Indeed, the *trans-cis* energy gap in these molecules is considerably larger than in the corresponding hydrocarbon chains, thereby strongly suppressing the concentration of *gauche* defects in the chains. Moreover, the repulsion between the fluorine atoms imposes a superhelical twist on the chain, introducing a cylindrical symmetry which is absent in the planar, all *trans*, hydrocarbon chains. Because these chains are stiff and the concentration of *gauche* defects negligibly small, the relaxation to equilibrium following a change in surface pressure is very rapid. This explains why the isotherms of perfluorinated amphiphile monolayers display good reversibility and long term stability even in the density range where the molecules are close-packed. Our previous studies have shown that monolayers of $F(CF_2)_{11}COOH$ and $F(CF_2)_{10}CH_2COOH$ support only two phases in the temperature range 2-30 °C ; a gas phase at low surface coverage and an ordered condensed phase at high surface coverage, with an intermediate two-phase coexistence region. In the ordered phase, the measured first order X-ray diffraction peaks and rod scans are consistent with a structure in which the molecules are sensibly vertical and the projection of the unit cell in the monolayer-water is hexagonal [12, 13]. Recent molecular dynamics simulations also lead to the same conclusion [14].

In this paper we report new measurements of the (1, 0), (1, 1) and (2, 0) peaks in the grazing incidence X-ray diffraction pattern of monolayers of $F(CF_2)_{11}COOH$ and $F(CF_2)_{10}CH_2COOH$ supported on water. With these data we test the model structure functions. Although the signal-to-noise ratio for the highest order peaks which we have studied is poor, it is still possible to use the data to make a meaningful comparison of the intensity ratios of the peaks and thereby infer that in a monolayer of $F(CF_2)_{11}COOH$ there is azimuthal ordering of the close packed molecules. On the other hand, the results of the corresponding analysis for a monolayer of close packed $F(CF_2)_{10}CH_2COOH$ molecules do not distinguish between structures with and without azimuthal ordering.

2. Experimental details.

The grazing incidence X-ray diffraction measurements reported in this paper were carried out on the D24 line at the LURE synchrotron source (Orsay, France). Figure 1 displays a sketch of

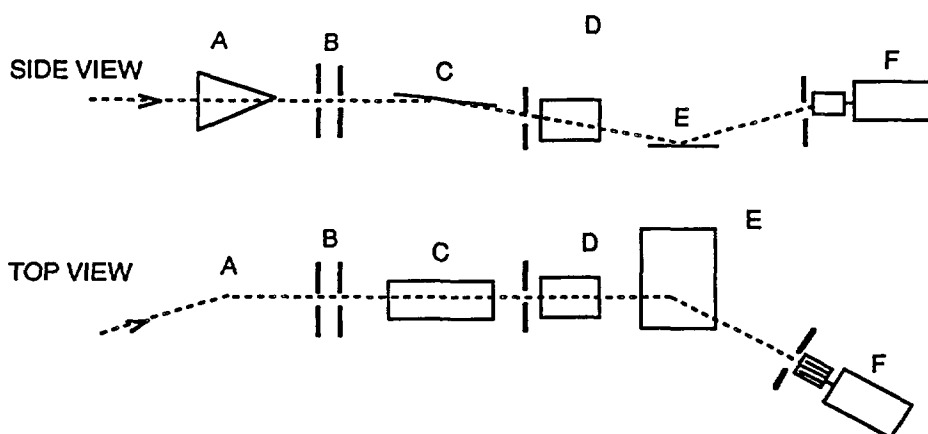

Fig. 1. — Schematic of the experimental set up for grazing incidence X-ray diffraction. (A) bent Ge(111) monochromator ; (B) slits ; (C) mirror ; (D) ionization chamber ; (E) Langmuir trough ; (F) NaI detector.

the experimental set-up. A bent Ge (111) monochromator was used to select the X-ray wavelength ($\lambda = 1.49 \text{ \AA}$) and an uncoated glass mirror was used to deflect the X-ray beam down onto the sample. The angle of incidence was 1.42 mrad, which is below the critical angle θ_c for total external reflection of X-rays. The incident beam intensity was monitored with an ionisation chamber and the diffracted beam intensity measured with a NaI detector equipped with Soller slits that had an acceptance angle of 0.15° . With this arrangement the in-plane resolution was 0.0075 \AA^{-1} .

Since the X-rays from the synchrotron are strongly polarised in the plane of the monolayer-water interface, the scattered X-ray intensity falls off rapidly with increasing scattering angle. Moreover, the CF_2 structure function has a minimum value near zero at 1.75 \AA^{-1} and increases only slowly thereafter. These effects limit both the angular range over which diffraction from the monolayer can be observed and the signal-to-noise ratio achievable in measurements of the intensities of the higher order diffraction peaks. To reduce parasitic scattering the incident X-ray beam was conducted through evacuated or helium-filled tubes wherever possible, and lead tape was used to shield all windows. We did not carry out rod scans of the (1, 0) diffraction peak since previous studies [12, 13] have shown that in the dense close packed phase of these amphiphiles, the molecules are normal to the water surface to within 5° . Instead, when collecting in-plane diffraction data the vertical component of the scattering vector, Q_z , was integrated from 0 to 3 \AA^{-1} , in order to collect all the scattered X-ray intensity. To obtain adequate signal-to-noise in the data it was necessary to count for at least one minute per point when traversing the (1, 0) peak and much longer per point when traversing the higher order peaks. The usual corrections for Compton scattering, polarisation, geometry of viewing the sample, etc. were applied to the data [15].

The monolayer isotherms (surface pressure *versus* area per molecule) were measured in a thermostated Teflon trough. The subphase was Millipore quality water with the pH adjusted to 2 using hydrochloric acid; the temperature of the trough was controlled to $\pm 0.5^\circ\text{C}$. The monolayer was prepared by spreading small aliquots of a dilute solution of the amphiphile in a 9 : 1 mixture of hexane and ethanol. After evaporation of the organic solvent the surface density of the amphiphiles was adjusted to the desired value by compression with a Teflon barrier. Both monolayers were studied at a surface density of one molecule per 30 \AA^2 . This is very near to the densest monolayer state but well below the monolayer collapse. The surface tension was measured by the Wilhelmy method using a platinum plate. At one molecule per 29 \AA^2 , the surface pressure of monolayers of $\text{F}(\text{CF}_2)_{10}\text{CH}_2\text{COOH}$ was 2.5 dyne/cm; this surface pressure was constant to better than 0.2 dyne/cm over the duration of the X-ray scattering experiment (several hours). Correspondingly, at a surface density of one molecule per 29 \AA^2 , the surface pressure of monolayers of $\text{F}(\text{CF}_2)_{11}\text{COOH}$ was 27 dyne/cm; this surface pressure was also constant to better than 2 dyne/cm over the duration of the X-ray scattering experiment.

3. Experimental results.

Figure 2 shows that monolayers of the two amphiphiles studied have very similar isotherms in the πA plane. Since these isotherms are discussed in more detail elsewhere [12, 13], we mention only a few pertinent points. We interpret the interval from the largest area per molecule for which there is a measured surface pressure to about 35 \AA^2 per molecule as the coexistence region between a disordered gaseous phase and the ordered condensed phase. Reduction of the area per molecule to values less than about 35 \AA^2 generates a rapid increase in the surface pressure indicating that the monolayer is now in its ordered condensed phase characterized by a low compressibility. We find that as long as the surface pressure is less than

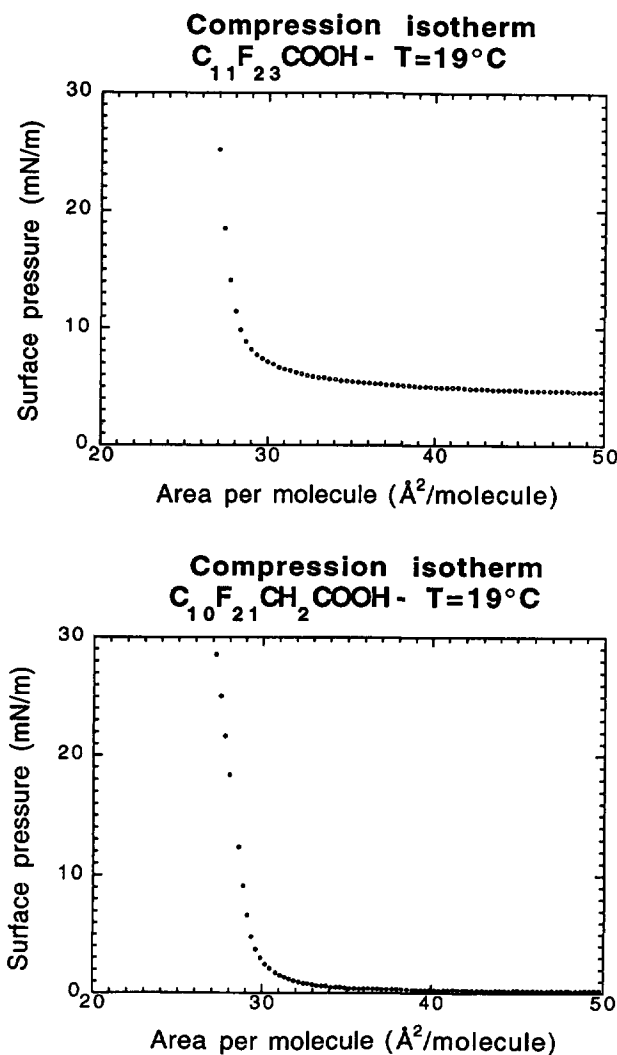

Fig. 2. — Surface pressure-area per molecule isotherms at 19 °C for monolayers of C₁₀F₂₁CH₂COOH and C₁₁F₂₃COOH.

about 5-7 dyne/cm, the system is stable in the dual sense that the surface pressure at any given area per molecule is independent of time and that the isotherm is reversible upon re-expansion to larger area per molecule. The principal difference between the isotherms of the monolayers of the two amphiphiles is the surface pressure in the coexistence region which, at 17 °C, is 0.3 dyne/cm for F(CF₂)₁₀CH₂COOH and 5 dyne/cm for F(CF₂)₁₁COOH. Our interpretation of this difference in surface pressure is discussed in reference [13].

Figure 3 is an illustration for both monolayers of the X-ray diffraction peaks observed under grazing incidence at 18 °C and 30 Å² per molecule ; the surface pressures were 2.5 dyne/cm and 27 dyne/cm for F(CF₂)₁₀CH₂COOH and F(CF₂)₁₁COOH respectively. To our knowledge, this is the first time that diffraction peaks at such high Q value have been observed in Langmuir monolayers. In each case, three diffraction peaks were observed with scattering vectors related by $Q_2 = \sqrt{3} Q_1$ and $Q_3 = 2 Q_1$. These scattering vectors can be indexed as (1, 0), (1, 1) and

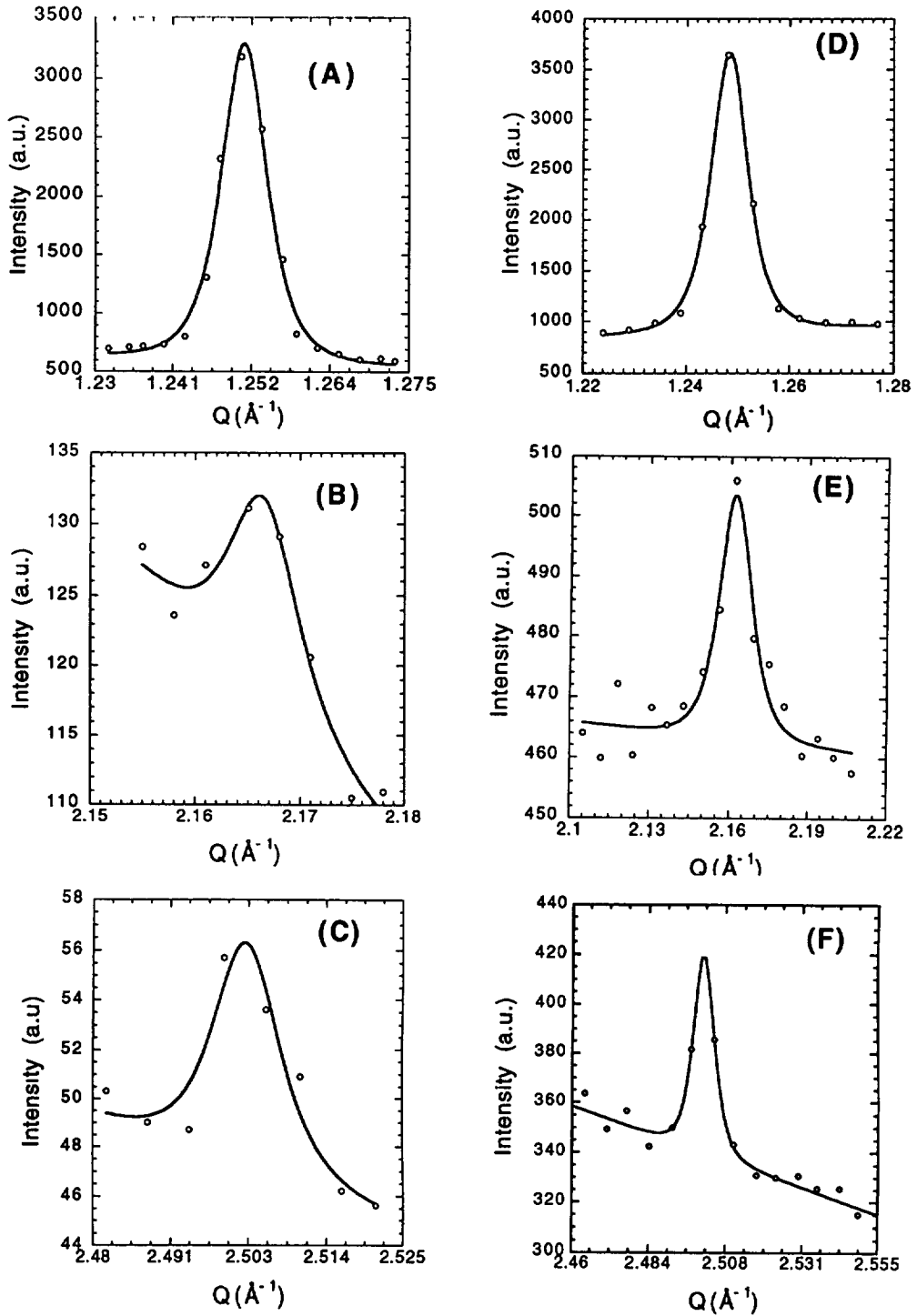

Fig. 3. — Typical diffraction data : (A), (B) and (C) are respectively the (1, 0), (1, 1) and (2, 0) diffraction peaks from monolayer of $\text{F}(\text{CF}_2)_{10}\text{CH}_2\text{COOH}$ at 18°C ; (D), (E) and (F) are respectively the (1, 0), (1, 1) and (2, 0) peaks of $\text{F}(\text{CF}_2)_{11}\text{COOH}$. The solid lines are Gaussian fits (plus a sloping background) to experimental data.

(2, 0) in a two-dimensional hexagonal lattice. For both systems, we have checked that the intensity of the (1, 0) peak was independent of the rotation of the trough. This confirms that the monolayer can be considered as a two-dimensional powder for the purpose of interpreting the X-ray diffraction data. The signal-to-background ratio in the experiments reported is greater than 2.5 for the (1, 0) peak and decreases to 0.1 for the (2, 0) peak. The major part of the background scattered X-ray intensity arises from the substrate. Despite the unfavourable signal-to-background ratio of the intensity of the (2, 0) peak it is still possible to use the data obtained in an analysis of the structure functions of models of the packing in the monolayer.

We have fitted the X-ray diffraction data to a superposition of a standard line shape function and a background function determined by fitting the data on each side of a peak and extrapolating across the base of the peak. Gaussian and Lorentzian line shape functions are found to fit the experimental data equally well. Therefore we will only present the results obtained from fits to a Gaussian line shape (Tab. I). For almost all of the peaks studied we find that the widths of the diffraction peaks are resolution-limited by our instrumental set-up, which implies that the translational coherence length in these monolayers is greater than 300 Å. We believe that the apparent larger widths of the (2, 0) peak of the $F(CF_2)_{10}CH_2COOH$ monolayer and of the (1, 1) peak of the $F(CF_2)_{11}COOH$ monolayer are due to the poor signal-to-noise ratio (see Fig. 3) [15]. We note that for both monolayers studied the intensity of the (1, 1) peak is almost the same as that of the (2, 0) peak, even though the former is observed at smaller momentum transfer Q . This is a consequence of the Q -dependence of the structure factor of the CF_2 group, which goes through a minimum which almost vanishes at 1.75 \AA^{-1} and increases only slowly as Q increases further. On the other hand, the ratio of the intensity of the (1, 1) peak to that of the (1, 0) peak is significantly smaller for $F(CF_2)_{10}CH_2COOH$ than for $F(CF_2)_{11}COOH$ (Tab. II).

Table I. — *Intensity, Position and Full Width at Half Maximum (FWHM) of the diffracted peaks resulting from a Gaussian fit. The peaks have been indexed (1, 0), (1, 1) and (2, 0) according to a hexagonal structure.*

Molecule	Peak	I (u.a.)	Q (Å ⁻¹)	FWHM
C ₁₀ F ₂₁ CH ₂ COOH	(1, 0)	23.7±0.2	1.251±0.001	0.0074
	(1, 1)	0.1±0.07	2.167±0.001	0.0076
	(2, 0)	0.1±0.08	2.503±0.0025	0.0113
C ₁₁ F ₂₃ COOH	(1, 0)	28.5±0.3	1.249±0.001	0.0077
	(1, 1)	0.54±0.16	2.162±0.003	0.0177
	(2, 0)	0.59±0.11	2.501±0.007	0.0081

4. Discussion.

The relative locations of the observed diffraction peaks for both monolayers studied, and the absence of splitting imply that the unit cells in the monolayer-water interface are hexagonal. The unit cell areas are slightly greater than 29 Å² which is in good agreement with the so-called limiting areas derived from the monolayer isotherms and which are found to be 29.8 Å². The values of the lattice parameters, deduced from the fits of the diffraction peaks are 5.82 Å for $F(CF_2)_{11}COOH$ and 5.79 Å for $F(CF_2)_{10}CH_2COOH$. The tendency of a smaller lattice

Table II. — *Peak Intensity ratios calculated for several models without Debye-Waller correction : free rotator model (rotator) and azimuthally ordered model. The experimental intensity ratios between the (h, k) and (1, 0) peaks have also been indicated for both molecules.*

Molecule	Peak	I/I(10) exp.	Azimuthally ordered	rotator
C ₁₀ F ₂₁ CH ₂ COOH	(1, 0)	1	1	1
	(1, 1)	0.0041±73%	0.055	0.0142
	(2, 0)	0.0043±79%	0.118	0.0343
C ₁₁ F ₂₃ COOH	(1, 0)	1	1	1
	(1, 1)	0.019±9%	0.086	0.0245
	(2, 0)	0.021±18%	0.159	0.0505

parameter observed for the F(CF₂)₁₀CH₂COOH is interesting. We interpret this difference as a manifestation of the change in potential energy that accompanies the substitution of a CH₂ for a CF₂ near the head group of the molecule. As shown in the Appendix, conventional values for the CH₂ and CF₂ group interactions are adequate to account for the observed difference in the lattice parameters. It is also interesting to compare the cross-sectional areas measured in monolayers with those reported in the bulk phases of perfluoroalkane crystals. If the amphiphile molecules were perfect cylinders and the monolayer were to be represented as an array of hexagonally packed vertical cylinders in contact, our data imply that each molecule would have a cross sectional area of 26.5 Å², since the coverage of the plane by close-packed discs is 91 %. By comparison, the cross sectional area per molecule is 25.5 Å² in 3D perfluoroalkane crystals, which have a lamellar structure [16]. The small difference between the monolayer and bulk crystal cross sectional areas per molecule is consistent with the expected higher density generated by the extra interlamellar interactions in the bulk crystal.

We now attempt to determine if the studied monolayers are better described as crystals of translationally and azimuthally ordered molecules or as plastic crystals with azimuthally disordered molecules. In the latter case the molecules are either randomly oriented or freely rotating about their long axes (free rotator phase). At first sight it seems that this issue is settled by the observation of hexagonal packing of the molecules in the monolayer, since this packing is usually considered as characteristic of the rotator II phase [11]. However, this observation is not sufficient to unambiguously identify this phase. A complete identification of the rotator II phase (or any other azimuthally disordered phase) requires in principle a quantitative comparison of the relative intensities of the various diffraction peaks with the calculated structure function assuming the absence of azimuthal ordering of the molecules. In the present experiments, a qualitative examination of the peak intensities is nevertheless already sufficient to assert that at least one of the monolayers studied here is not in a free rotator phase but presents some azimuthal order. Indeed, the two amphiphile molecules under consideration have very similar intramolecular structure factors, since they differ only by the replacement of one of eleven CF₂'s by a CH₂. As in a rotator II phase, this intramolecular structure factor is cylindrical (suppressing any azimuthal orientation correlation), we expect that the X-ray scattering cross sections of the two molecules should be nearly the same. Moreover, since the lattice spacing and symmetries of the two monolayers are identical one should find that the ratios of intensities of peaks in the diffraction patterns of the two monolayers are the same. The

data displayed in table II show that this is the case for the ratio I_{11}/I_{20} , but not for I_{11}/I_{10} or I_{20}/I_{10} . This discrepancy between expectation and observation suggests that both monolayers cannot be in the rotator phase. Note that we can make only this qualitative interpretation since the first three peaks of the highly symmetric hexagonal structure have been observed with both molecules. Indeed, a difference in the intensity ratio observed with only two diffraction peaks could be interpreted as a change in the Debye-Waller factor which leads to various dumping at high scattering vectors.

In an attempt to provide a quantitative basis for the inference we have just reached, we have calculated the structure functions for two models of the monolayer. One in which we assume a free rotation of the amphiphiles about their long axes, the other in which there is azimuthal ordering of the amphiphiles about their long axes. We first consider models in which all thermal motion is suppressed. In the azimuthally ordered phase the amphiphile molecules have fixed orientation of the molecular axis and fixed location in the space lattice. The structure factor for this phase is

$$F(\mathbf{Q}) = \sum_i f_i(\mathbf{Q}) \exp(i\mathbf{Q} \cdot \mathbf{r}_i) \quad (1)$$

where the sum is taken over all the atoms of the molecule. We use for the \mathbf{r}_i the coordinates given in reference [16]. The bisector of the CF_2 group adjacent to the head group has been aligned with the \mathbf{a} axis (we have checked that this relative orientation has little influence on the calculated intensities). In the rotator phase the molecular axes are located at the points of a hexagonal space lattice but the molecules are uniformly distributed in azimuthal angle. For this model the structure factor simplifies to [17]

$$F(\mathbf{Q}) = \sum_i f_i(\mathbf{Q}) J_0(i\mathbf{Q} \cdot \mathbf{r}_i) \quad (2)$$

where J_0 is the Bessel function of zero order.

The calculated structure functions for both the rotator and the non rotator model are displayed in table II. We note that different intensity ratios I_{11}/I_{10} and I_{20}/I_{10} are obtained but that in none of the models they agree with the experimental values (which are lower for high order peaks).

Better agreement with experiment can be achieved by including a Debye-Waller factor in the calculation of the structure factor. For this, a very simple model for the thermal motion of the molecules in the monolayer was selected. Specifically, we neglect the effect of thermal excitation of molecular tilting and of motion perpendicular to the monolayer-water interface, i.e. we restrict all of the vibrations of interest to be parallel to the monolayer-water interface. Furthermore, we assume that it is sufficiently accurate to treat the in-plane vibrations of the rigid amphiphile molecules as isotropic, whereupon the Debye-Waller factor takes the simple form $\exp(-\alpha Q^2)$. As the shape of the diffraction peaks remains Gaussian in the limit of our experimental resolution, this last assumption is reasonable. The values of α for the rotator and azimuthally ordered structures were determined by a least squares fit of the theoretical diffraction peak intensity ratios to the observed diffraction peak intensity ratios. The results of these calculations are displayed in figure 4.

For $\text{F}(\text{CF}_2)_{10}\text{CH}_2\text{COOH}$, we obtain $\alpha = 0.41$ ($\chi^2 = 0.00098$) for the rotator model corresponding [2] to a mean square displacement of the center of mass with respect to the lattice site $\langle u^2 \rangle = 0.8 \text{ \AA}^2$, and $\alpha = 0.86$ ($\chi^2 = 0.00016$) for the azimuthally ordered model corresponding to $\langle u^2 \rangle = 1.7 \text{ \AA}^2$. Both of these α values are coherent with what is typically measured ($\alpha = 0.001$ to 0.5) in the bulk phase of molecular crystals. Therefore it appears that both the rotator and the azimuthally ordered models can satisfactorily describe our diffraction data.

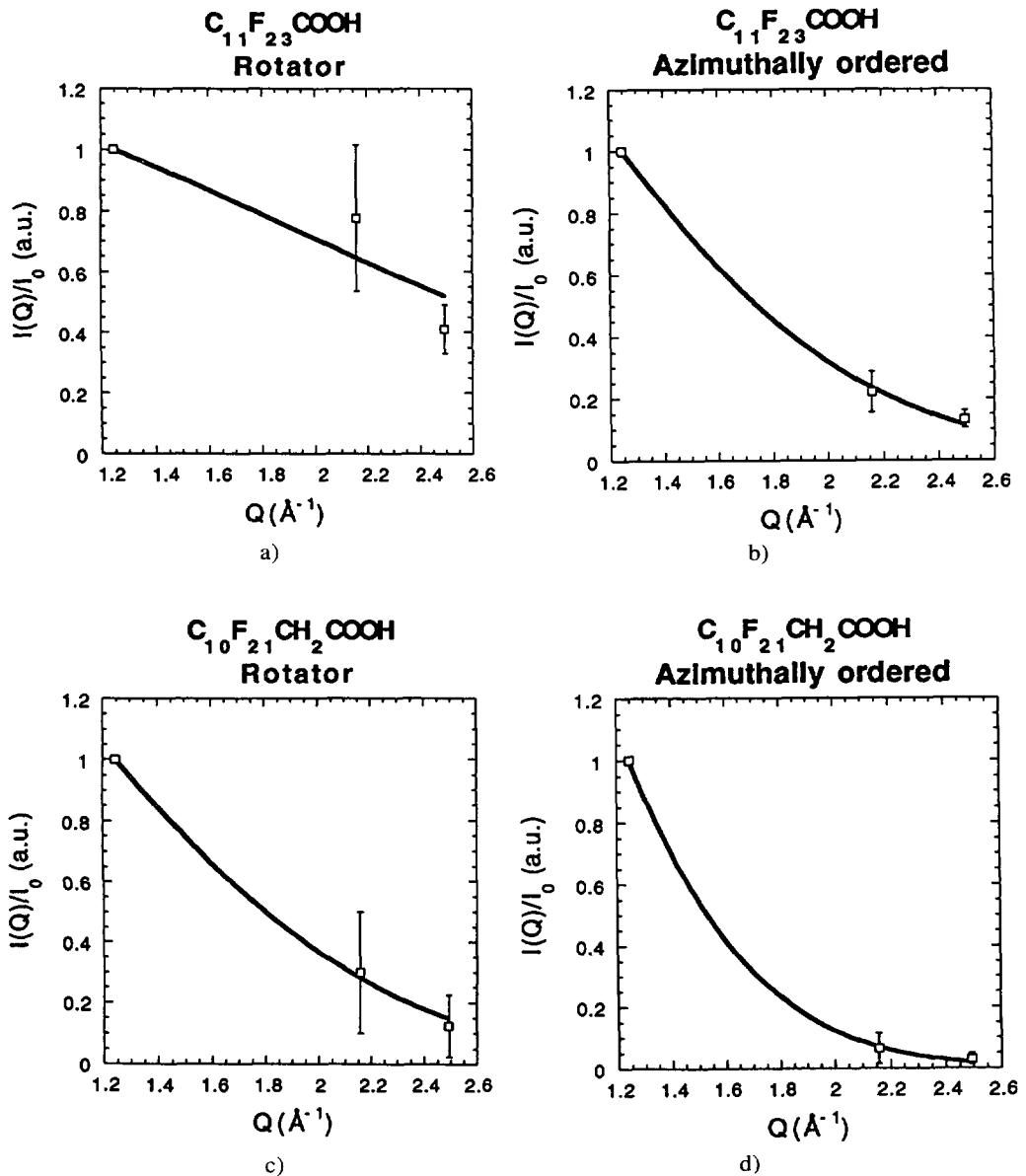

Fig. 4. — The ratio of the intensity $I(Q)$ over incident intensity I_0 as a function of Q^2 . Panels (a) and (b) are for $F(CF_2)_{11}COOH$ and panels (c) and (d) for $F(CF_2)_{10}CH_2COOH$. The experimental intensities have been normalized by setting $\frac{I_{hk}^{exp}/I_{10}^{exp}}{I_{hk}^{mod}/I_{10}^{mod}} = e^{-\alpha(Q_{hk}^2 - Q_{10}^2)}$. The solid line is the least square fit of this function to the experimental data using α as the adjustable parameter.

For the $F(CF_2)_{11}COOH$ monolayer, it is striking that no satisfactory agreement between the predicted and observed diffraction peak intensity ratios can be achieved with the rotator model for any value of the Debye-Waller factor. The best least square fit yields $\alpha = 0.14$ ($\chi^2 = 0.0285$) but figure 4 shows that the calculated curve is unable to pass through the

experimental data points. Moreover the χ^2 value is 0.0285, about 3 orders of magnitude larger than in the case of $F(CF_2)_{10}CH_2COOH$. Increasing α to 0.17 would allow the calculated intensities to fall within those error bars but then the χ^2 reaches an even larger value of 0.0362 (note that these error bars are larger by using a maximum entropy algorithm for the peak fitting than with a least square fit). By contrast, an extremely good agreement is found for the azimuthally ordered model when $\alpha = 0.45$ ($\chi^2 = 0.00047$), which corresponds to $\langle u^2 \rangle = 0.9 \text{ \AA}^2$. Considering these results plus our former qualitative discussion, we thus conclude that $F(CF_2)_{11}COOH$ molecules at high surface density are not in a rotator phase but exhibit some degree of azimuthal ordering. This sets a case example showing that the observation of an in-plane hexagonal structure does not necessarily mean a free rotator phase, especially when the molecule cross section appears circular.

Because of the similarities in the intramolecular structures, it is tempting to infer that the close packed monolayer of the $F(CF_2)_{10}CH_2COOH$ molecules also has azimuthal ordering. However, our present evidence is indirect and has yet to be substantiated. If this were indeed true, the difference experimentally observed in the mean square amplitude of positional fluctuations in our model of azimuthally ordered $F(CF_2)_{10}CH_2COOH$, 1.7 \AA^2 , and $F(CF_2)_{11}COOH$, 0.9 \AA^2 could be easily rationalized. First the size of the CH_2 groups is much smaller than for CF_2 groups. Second, the diffraction data were collected at different surface pressures (2.5 and 27 dyne/cm, respectively) : a higher pressure is expected quite normally to dump out the amplitude of thermal fluctuations.

The preceding conclusions indicate that the structure of a monolayer of a perfluorinated amphiphile is subtly different from that of the corresponding hydrocarbon amphiphile. Perhaps the almost total absence of gauche defects in the fluorocarbon amphiphile and the helical superstructure of the rigid molecule gives greater susceptibility of the overall molecular structure to small perturbation terms in the interaction molecular potential, which favours more organized arrangements. In the other case, the effects of these small terms in the intermolecular interactions may be masked by the flexibility of the chain and introduces disorder.

Acknowledgements.

We are grateful to I. R. Peterson and B. Croset for many helpful discussions and remarks and to P. Vachette and C. Bourgeaux for beam time. This research was supported by the Direction des Etudes et Recherches Techniques under contract DRET 901527, the Société Nationale Elf Aquitaine (Direction de la Recherche, du Développement et de l'Innovation) and by the National Science Foundation. The Laboratoire de Physico-Chimie des Surfaces et Interfaces is associated to the C.N.R.S. (URA 1379) and to the Université Pierre et Marie Curie (Paris VI).

Appendix.

To help interpret the observed difference between the lattice spacing in monolayers of $F(CF_2)_{11}COOH$ and $F(CF_2)_{10}CH_2COOH$ we have calculated the lattice spacing at $T = 0 \text{ K}$ for each of these monolayers using the same pseudoatom model as employed in the molecular dynamics simulations of Shin, Collazo and Rice [14]. Since we wish to understand the origin of the difference in the lattice spacings that accompanies replacement of one CF_2 by one CH_2 , the substitution of a minimization of the lattice energy for a minimization of the lattice free energy is not expected to alter the qualitative aspects of the analysis. The amphiphile molecules were assumed to have zero collective tilt and to be packed in a hexagonal lattice. The model of the amphiphile chain we used represents the CF_2 , CH_2 and $COOH$ groups as spherical pseudoatoms, and includes the fixed C-C bond length and C-C-C bond angles as well

as the superhelical twist imposed by the F-F repulsion along the chain ; a detailed description of this model can be found in reference [14].

The energy of the monolayer depends on the orientations of the amphiphile molecules. We have considered five cases with different values for the angle between the bisector of the FCF bond angle (or the HCH bond angle) of the group adjacent to the COOH group and the **a**-axis of the unit cell in the monolayer/water interface : (i) all of the amphiphile molecules have the FCF bisector pointing towards the nearest neighbour lattice site ; (ii) all of the amphiphile molecules have the FCF bisector pointing towards the next nearest neighbor lattice site ; (iii) the bisector of the FCF group is randomly oriented in the interval 0° - 30° relative to the **a**-axis of the unit cell ; (iv) the bisector of the FCF group is randomly oriented in the interval 0° - 90° relative to the **a**-axis of the unit cell ; (v) the bisector of the FCF group is randomly oriented in the complete interval 0° - 360° relative to the **a**-axis of the unit cell. In every case we find that the lattice spacing in a monolayer of $F(CF_2)_{11}COOH$ is greater than in a monolayer of $F(CF_2)_{10}CH_2COOH$, as shown below.

Calculated lattice spacings ($T = 0$ K) for monolayers of fluorinated amphiphiles.

Orientation of FCF bisector	$C_{11}F_{23}COOH$ a (Å)	$C_{10}F_{21}CH_2COOH$ a (Å)	Δ δa (Å)
NN	5.645	5.585	0.055
NNN	5.645	5.585	0.055
$\Delta\theta = 30^\circ$	5.660	5.590	0.070
$\Delta\theta = 90^\circ$	5.708	5.560	0.068
$\Delta\theta = 360^\circ$	5.895	5.834	0.061

It is clear that the calculated difference between the lattice spacings of the two monolayers is consistent with the observed value or, put in another way, that the substitution of a CH_2 group for a CF_2 group in the twelve carbon amphiphile molecule is the source of the observed lattice contraction. The absolute magnitudes of the calculated lattice spacings are slightly smaller than the observed values, which is likely due both to inaccuracies in the potential parameters used and to the neglect of thermal expansion in the model calculation. To the extent that the trends in the lattice spacing with extent of azimuthal ordering are accurately reproduced by the model calculation, comparison of the calculated and observed lattice spacings favors a model with some degree of azimuthal ordering.

References

- [1] Peierls R. E., *An. Inst. Henri Poincaré* **5** (1935) 177 ;
Landau L. D., *Z. Phys. Sowjet.* **11** (1937) 545.
- [2] Phase Transition in Surface Films, J. G. Dash and J. Ruvalds Eds. (Plenum, New York, 1980) ;
Ordering in Two Dimensions, S. K. Sinha Ed. (North Holland, Amsterdam, 1980) ;
Two-Dimensional crystals, I. Lyuksytov, A. G. Naumovets and V. Pokrovsky Eds. (Academic Press, San Diego, 1992).
- [3] Möhwald H., *Annu. Rev. Phys. Chem.* **41** (1990) 441 ;
McConnell H., *Annu. Rev. Phys. Chem.* **42** (1991) 171.

- [4] Langmuir I., *J. Am. Chem. Soc.* **39** (1917) 1848.
- [5] Insoluble Monolayers at Gas-Liquid Interfaces, G. L. Gaines, Jr Ed. (Interscience, New York, 1965);
Bibo A. M. and Peterson I. R., *Adv. Mater.* **2** (1990) 309 ;
Knobler C. M. and Desai R. C., *Annu. Rev. Phys. Chem.* **43** (1991).
- [6] Qui X., Ruiz-Garcia J., Stine K., Knobler C. M. and Selinger J. V., *Phys. Rev. Lett.* **67** (1991) 703.
- [7] Garoff S., Deckman H. W., Dunsmuir J. H., Alvarez M. S. and Bloch J. M., *J. Phys. France* **47** (1986) 701.
- [8] Moy V. T., Keller D., Gaub H. E. and McConnel H. M., *J. Phys. Chem.* **90** (1986) 3198.
- [9] Kenn R. M., Böhm C., Bibo A. M., Peterson I. R., Möhwald H., Kjaer K. and Als Nielsen J., *J. Phys. Chem.* **95** (1991) 2092.
- [10] Kjaer K., Als-Nielsen J., Helm C. A., Laxbauer L. A. and Möhwald H., *Phys. Rev. Lett.* **58** (1987) 2224 ;
Dutta P., Peng J. B., Lin B., Ketterson J. B., Prakash M., Georgopoulos P. and Ehrlich S., *Phys. Rev. Lett.* **58** (1987) 2228 ;
Helm C. A., Möhwald H., Kjaer K. and Als-Nielsen J., *Biophys. J.* **52** (1987) 381 ;
Barton S. W., Thomas B. N., Flom E. B., Rice S. A., Lin B., Peng J. B., Ketterson J. B. and Dutta P., *J. Chem. Phys.* **89** (1988) 2257 ;
Lin B., Shih M. C., Bohanon T. M., Ice G. E. and Dutta P., *Phys. Rev. Lett.* **65** (1990) 191 ;
Kenn R. M., Böhm C., Bibo A. M., Peterson I. R., Möhwald H., Als-Nielsen J. and Kjaer K., *J. Phys. Chem.* **95** (1991) 2456.
- [11] Shih M. C., Bohanon T. M., Mikrut J. M., Zschack P. and Dutta P., *Phys. Rev. A* **45** (1992) 5734.
- [12] Barton S., Goudot A., Bouloussa O., Rondelez F., Lin B., Novak F., Acero A. and Rice S., *J. Chem. Phys.* **96** (1992) 1343.
- [13] Acero A., Li M., Lin B., Rice S. A., Goldmann M., Ben Azouz I., Goudot A. and Rondelez F., *J. Chem. Phys.* **99** (1993) 7214.
- [14] Shin S., Collazo N. and Rice S. A., *J. Chem. Phys.* **96** (1992) 1353.
- [15] Kjaer K., Als-Nielsen J., Helm C. A., Tippman-Krayer P. and Möhwald H., *J. Phys. Chem.* **93** (1989) 3200 ;
The Optical Principles of the Diffraction of X-rays ; R. W. James Ed. (Ox Bow, Woodbridge, 1982) ;
X-rays in Theory and Experiment, A. H. Compton and S. K. Allison Eds. (Van Nostrand, New York, 1948).
- [16] Schwickert H., Strobl G. and Kimmig M., *J. Chem. Phys.* **95** (1991) 2800.
- [17] Oster G. and Riley D. P., *Acta Crystallogr.* **5** (1952) 272.