



HAL
open science

New ways to measure the work function difference in MOS structures

S.K. Krawczyk, H.M. Przewlocki, A. Jakubowski

► **To cite this version:**

S.K. Krawczyk, H.M. Przewlocki, A. Jakubowski. New ways to measure the work function difference in MOS structures. *Revue de Physique Appliquée*, 1982, 17 (8), pp.473-480. 10.1051/rphysap:01982001708047300 . jpa-00245024

HAL Id: jpa-00245024

<https://hal.science/jpa-00245024>

Submitted on 4 Feb 2008

HAL is a multi-disciplinary open access archive for the deposit and dissemination of scientific research documents, whether they are published or not. The documents may come from teaching and research institutions in France or abroad, or from public or private research centers.

L'archive ouverte pluridisciplinaire **HAL**, est destinée au dépôt et à la diffusion de documents scientifiques de niveau recherche, publiés ou non, émanant des établissements d'enseignement et de recherche français ou étrangers, des laboratoires publics ou privés.

Classification
 Physics Abstracts
 73.40Q

New ways to measure the work function difference in MOS structures (*)

S. K. Krawczyk (**) (+), H. M. Przewłocki (***) and A. Jakubowski (**)

(**) Institute of Electron Technology, Technical University of Warsaw, Koszykowa 75, 00-662 Warsaw, Poland

(***) Institute of Electron Technology, Al. Lotników 32/46, 02-668 Warsaw, Poland

(Reçu le 22 septembre 1981, révisé les 29 mars et 4 mai 1982, accepté le 6 mai 1982)

Résumé. — On a élaboré deux nouvelles méthodes de détermination du potentiel de contact dans les structures MOS. On a mis ces méthodes en pratique et les valeurs de ϕ_{MS} obtenues par elles ainsi que celles d'autres auteurs s'accordent bien. Les méthodes sont simples et plus faciles à appliquer que celles généralement utilisées dans la détermination de ϕ_{MS} .

Abstract. — Two new techniques for contact potential difference determination in MOS structures have been developed. These techniques were applied in practice yielding ϕ_{MS} values remaining in close agreement with each other, and within the range of ϕ_{MS} values obtained by other authors. These techniques are simple and much easier in application than the commonly used methods of ϕ_{MS} determination.

1. Introduction. — The work function difference (WFD) in MOS structures is the difference of the energy required to raise an electron from the Fermi level in the semiconductor to the conduction band of the insulator ($q\phi_{Si}$), and the energy ($q\phi_m$) required to raise an electron from the Fermi level in the gate material to the conduction band in the insulator.

The contact potential difference (CPD) in MOS structures ϕ_{MS} is correspondingly defined here, for the flat band situation, as :

$$\phi_{MS} = \phi_m - \phi_{Si} \tag{1}$$

where ϕ_m and ϕ_{Si} are potential barrier heights at the gate material-insulator, and semiconductor insulator interfaces, as shown in figure 1, in which other potentials used in this work are also indicated. Both ϕ_m and ϕ_{Si} are considered here to be positive values, in accordance with the sign convention commonly used in the literature of the subject [1-10] ⁽¹⁾.

The value of ϕ_{MS} is an important parameter of any MOS device. Basic electrical characteristics of MOS

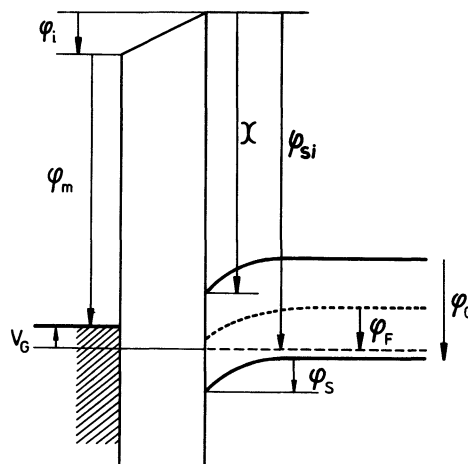

Fig. 1. — The band diagram of the MOS structure. The potentials used in this work are indicated.

integrated circuits and transistors depend on the value of ϕ_{MS} . In particular, the threshold voltage V_T , which is a fundamental parameter of these devices, may often be expressed by the following formula ⁽²⁾ :

$$V_T = \phi_{MS} - \frac{Q_{eff}}{C_i} + 2\phi_F - \frac{Q_B}{C_i} \tag{2}$$

⁽²⁾ In case of more sophisticated MOS transistor designs, more involved formulae are used, but the dependence of V_T on ϕ_{MS} remains essentially the same.

(*) Communication présentée à l'ESSDERC 1981.
 (+) Currently with Laboratoire d'Electronique, Automatique et Mesures Electriques, Ecole Centrale de Lyon, 36, av. G. de Collongue, 69130 Ecully, France.
 (1) This sign convention is different from the one used in our previous papers [14, 15].

where Q_{eff} and Q_B are respectively, the effective charge of the insulating layer ⁽³⁾, and depletion layer charge at the onset of strong inversion (per unit area), C_i is the insulator capacitance (per unit area), and ϕ_F is the electrostatic potential in the semiconductor bulk (see Fig. 1). The first two factors in this expression for V_T , yield the value of the flat band voltage V_{FB} , which is a gate voltage at which the energy bands in the semiconductor substrate are flat up to the semiconductor-insulator interface. Namely :

$$V_{\text{FB}} = \phi_{\text{MS}} - \frac{Q_{\text{eff}}}{C_i}. \quad (3)$$

In connection with equation (3) it is worthwhile to note that in the early days of MOS devices (in the sixties), the main contribution to the flat band voltage was due to the fixed oxide charge Q_f (and sometimes to other oxide and interface charges either), as illustrated schematically in figure 2. This situation stimulated many scientific programs and numerous research works, aimed at better understanding and better control of the oxide charges. The scale of this worldwide research effort is clearly illustrated by the bibliography of this, and related subjects, compiled by

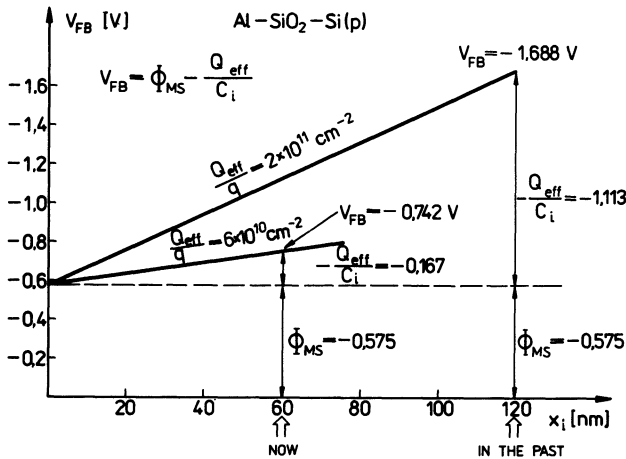

Fig. 2. — Schematic illustration of the contributions of ϕ_{MS} and Q_{eff}/C_i to the value of V_{FB} , in the past, and at present.

⁽³⁾ The effective charge of the insulating layer is defined by the following formula [16] :

$$Q_{\text{eff}} = Q_f + Q_{\text{it}} + \frac{1}{x_i} \int_0^{x_i} x \rho_{\text{ot}}(x) dx + \frac{1}{x_i} \int_0^{x_i} x \rho_m(x) dx$$

in which Q_f , Q_{it} are the surface densities of the fixed insulator charge, and interface trapped charge, ρ_{ov} , ρ_m are the volume densities of insulator trapped charge and mobile ionic charge [11], x is the coordinate perpendicular to the gate-insulator and insulator-semiconductor interfaces ($x = 0$ at gate-insulator, and $x = x_i$ at insulator-semiconductor interfaces). Usually, in MOS structures applied in practice, the fixed oxide charge Q_f is a dominating factor in the total Q_{eff} value.

Agajanian [12], while the current understanding of these phenomena was summarized by Deal [13]. Resulting from this effort, is a much better control of oxide charges, and lower values of Q_{eff} typically obtained in manufacturing of MOS devices. Much less attention has been paid till now to the CPD contribution to the flat band voltage since ϕ_{MS} was usually treated as a fundamental property of the gate and substrate materials used.

Lower Q_f values, together with higher insulator capacitances usually obtained in modern « scaled down » MOS devices, have led to the situation — often observed in nowadays MOS products — in which ϕ_{MS} becomes the dominating factor in the value of the flat band voltage, as shown in figure 2.

This fact, and the differences in ϕ_{MS} values obtained by various authors (as discussed below), indicate the need for better understanding of the CPD behaviour in MOS structures.

2. Measurement results and measurement techniques reported in the literature. —

In modern MOS circuits, the absolute values of threshold voltages are often lower than 1 V, in which case there is a strong influence of ϕ_{MS} on the value of V_T . In such cases it is particularly important to know the exact value of the CPD between the semiconductor substrate and the gate material. In spite of that, ϕ_{MS} values given in the literature [5-10] differ considerably. This fact is illustrated in figure 3, for the Al-SiO₂-Si system, to which the experimental part of this work is limited.

As can be seen in figure 3, the values obtained by Werner [6] for the Al-SiO₂-Si (n-type) system are more than 0.4 V higher than the values obtained by Kar [7]. Moreover, according to [6] the values of ϕ_{MS} are positive in this case (for the range of substrate doping applied in practice), while other authors claim it is negative [5, 7]. Various reasons have been proposed to explain the differences in ϕ_{MS} values obtained by the above mentioned authors. Haberle and Fröschle [8] found the CPD to depend on the silicon substrate orientation in such a way, that ϕ_{MS} becomes more positive in case of $\langle 100 \rangle$ orientation, than in the case of $\langle 111 \rangle$ orientation of the silicon substrate. Gaid and Kasprzak [9] explain the differences in ϕ_{MS} values reported in the literature, by the differences in MOS structure processing conditions, on the basis of atomic hydrogen chemisorption at the Si-SiO₂ interface. The dependence of ϕ_{MS} on MOS system processing conditions was supported by our results reported in [14] and [15]. Hickmott [10] discussed the influence of the dipole layers that exist at the Si-SiO₂, and metal-SiO₂ interfaces, or the dipole layers in the oxide, on the effective value of CPD. He pointed out at the complex phenomena that can take place at the metal-SiO₂ interface, which may influence the effective ϕ_{MS} values. In the literature available to the authors of this work no mention however was found concerning the changes in the effective ϕ_{MS} value resulting

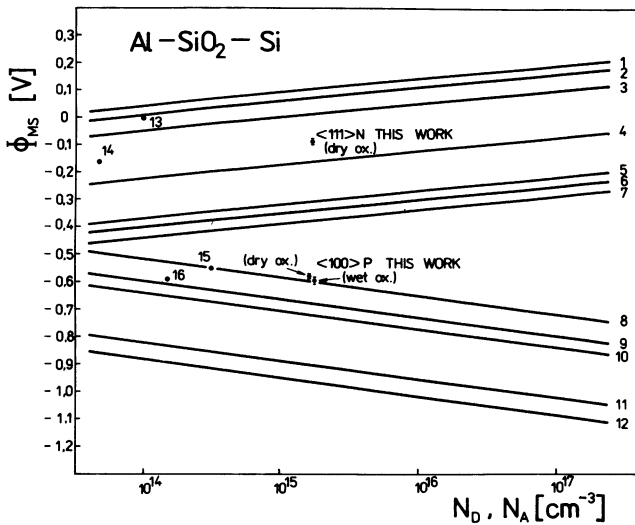

Fig. 3. — Results of ϕ_{MS} measurements obtained by various authors for differently processed Al-SiO₂-Si structures. Results of earlier works are shown as ϕ_{MS} vs. substrate doping (N_D or N_A) lines. Results obtained recently by Hickmott [10] and the results obtained in this work are shown by circles indicating the average values, while vertical bars indicate standard deviations of results obtained for one group of identically processed samples. (1) reference [8], substrate orientation $\langle 100 \rangle$, Si (n-type); (2) [6], $\langle 100 \rangle$, Si(n); (3) [9], $\langle 100 \rangle$, Si(n); (4) [9], $\langle 100 \rangle$, Si(n); (5) [5], $\langle 100 \rangle$, $\langle 111 \rangle$, Si(n); (6) [8], $\langle 111 \rangle$, Si(n); (7) [7], $\langle 100 \rangle$, Si(n); (8) [6], $\langle 100 \rangle$, Si(p); (9) [9], $\langle 100 \rangle$, Si(p); (10) [9], $\langle 111 \rangle$, Si(p); (11) [5], $\langle 100 \rangle$, $\langle 111 \rangle$, Si(p); (12) [7], $\langle 100 \rangle$, Si(p); (13) [10], $\langle 100 \rangle$, Si(n); (14) [10], $\langle 111 \rangle$, Si(n); (15) [10], $\langle 100 \rangle$, Si(p); (16) [10], $\langle 111 \rangle$, Si(p); ((13), (14), (15), (16) — samples annealed in forming gas, 400 °C).

from carrier trapping in the oxide layer, as described below. Nearly all the results of ϕ_{MS} measurements mentioned above, and shown in figure 3, were obtained using various forms of the classical method of flat band voltage determination for MOS capacitors with varying thickness of the dielectric layer [3, 4]. This method is based on equation (3). Which (if we assume that $Q_{eff} \approx Q_f$) may be rewritten in the following form :

$$V_{FB} = \phi_{MS} - \frac{Q_f}{\epsilon_i} x_i \quad (4)$$

where x_i , and ϵ_i are the insulating layer thickness, and permittivity of the insulator, respectively. The values of V_{FB} are measured for a series of MOS capacitors differing only in the thickness x_i of the oxide layer (otherwise the capacitors are assumed to be identical), and plotted against the x_i value for each capacitor, yielding a straight line, as given by (4). The extrapolation of this line to $x_i = 0$, gives :

$$V_{FB} = \phi_{MS} \quad (\text{for } x_i = 0) \quad (5)$$

allowing ϕ_{MS} determination for the measured series of MOS capacitors. The advantages and limitations of this measurement technique are discussed in detail in [3, 4] and [6-10]. In our opinion, the main limitations of this method are :

- the amount of preparatory work required to obtain one measurement result (one ϕ_{MS} value),
- the requirement that the MOS capacitors of one series (usually 5... 8 capacitors were used), differ only in the thickness of the dielectric layer x_i , being otherwise identical.

In their pioneering work on ϕ_{MS} determination [5], Deal *et al.* used photoelectric measurement of barrier heights at both Si-SiO₂ and metal-SiO₂ interfaces. From the difference of these heights they determined CPD for six groups of MOS structures with gates made of six different metals. Also, using the so obtained Al-SiO₂ barrier height, they determined ϕ_{MS} values and barrier heights for MOS structures with gates made of other metals. This was done by comparing the $C(V)$ characteristics of MOS structures which were assumed to differ only in the gate material. In this case the displacement between the $C(V)$ characteristic of a given MOS structure and the $C(V)$ characteristic of the Al-SiO₂-Si structure is due to the difference in metal-SiO₂ barrier heights, which can be so determined. Measurements reported in [5] were made on samples with p and n silicon substrates of $\langle 100 \rangle$, and $\langle 111 \rangle$ orientations. No differences in barrier heights, which might be attributed to silicon orientation were observed, and the barrier height values were reproducible to 0.1 V. The application of methods used in [5] for ϕ_{MS} determination is limited since the photoelectric method is not accurate enough to compensate for the difficulties involved in its application. The comparative method of $C(V)$ characteristics, on the other hand, is based on the assumption that the gate material constitutes the only difference between capacitors whose characteristics are compared, and very often, this is not the case.

3. New contact potential difference determination methods. — 3.1 THE PRINCIPLE OF THE PROPOSED METHODS. — Trying to explain the difference in ϕ_{MS} values found in the literature, new CPD measurement methods have been suggested recently [14, 15], and are further developed in this work.

The balance of potentials in the MOS structure is given by :

$$V_G - \phi_m = \phi_i - \chi - E_G/2q - \phi_F + \phi_s \quad (6)$$

where the various potentials used are defined in figure 1.

The contact potential difference ϕ_{MS} can be expressed in the following way :

$$\phi_{MS} = \phi_m - \chi - E_G/2q - \phi_F. \quad (7)$$

Combining equations (6) and (7), yields the following relation :

$$V_G = \varphi_i + \varphi_s + \phi_{MS}. \quad (8)$$

The idea of the proposed methods of ϕ_{MS} determination is based on the fact that if we find the gate voltage V_{GO} at which the potential drop across the insulating layer equals zero ($V_{GO} = V_G(\varphi_i = 0)$), and the surface potential $\varphi_{so} = \varphi_s(\varphi_i = 0)$, corresponding to V_{GO} , then, the CPD can be easily obtained as :

$$\phi_{MS} = V_{GO} - \varphi_{so}. \quad (9)$$

The proposed methods offer additionally as it is shown later, the possibility of separate determination of the Q_{eff} value.

In this work two methods of separate determination of ϕ_{MS} and Q_{eff} values are described. The common step in both of them is the determination of the V_{GO} value by photoelectric method (see section 3.2). The proposed methods differ in the procedure of φ_{so} determination. In one of them (method I) the ϕ_{MS} and Q_{eff} values are obtained from the measured V_{GO} and V_{FB} values. In the second one (method II) these values are calculated from measured V_{GO} and $C(V_{GO})$ values.

Since V_{GO} and φ_{so} are determined under illumination conditions, the effect of light induced generation on the properties of semiconductor surface region should be taken into account, in calculation of φ_{so} and Q_{eff} from the $C(V)$ data. This problem is discussed in section 3.3.

3.2 THE TECHNIQUE OF V_{GO} DETERMINATION. — The value of V_{GO} can be measured using a photoelectric method of Viswanathan and Ogura [17], illustrated in figure 4, in which a current-voltage $I_G(V_G)$ characteristic of UV illuminated MOS capacitor is monitored. The illumination is such that gate current consists of electrons excited from the gate material or from the semiconductor into the conduction band of the dielectric. This current changes sign for $\varphi_i = 0$ (which happens for $V_G = V_{GO}$), allowing determination of the V_{GO} value.

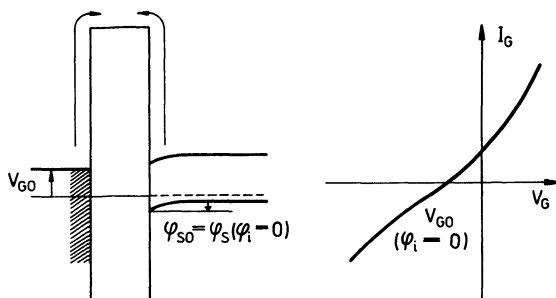

Fig. 4. — Illustration of the photoelectric method used to measure the gate voltage V_{GO} , at which potential drop across the insulating layer equals zero ($\varphi_i = 0$).

3.3 SEMICONDUCTOR SURFACE REGION UNDER ILLUMINATION CONDITIONS. — The influence of illumination on electrical properties of a MOS structure has already been analysed in a number of works [e.g. 18-23]. In [22, 23] it was shown, that phenomena occurring in a MOS structure under illumination can be described in a similar way as for the same structure in the dark, provided the Fermi potential $u_F = \varphi_F q/kT$ is replaced by effective Fermi potential $u_F^* = \varphi_F^* q/kT$ and the intrinsic concentration n_i , by effective intrinsic concentration n_i^* . The u_F^* and n_i^* are defined by equations (10) and (11), respectively :

$$u_F^* = \frac{1}{2} \ln \left[\frac{\xi + e^{u_F}}{\xi + e^{-u_F}} \right] \quad (10)$$

$$n_i^* = n_i [(\xi + e^{u_F})(\xi + e^{-u_F})]^{1/2} \quad (11)$$

where ξ is the effective level of light-induced generation defined as :

$$\xi = \frac{\Delta n}{n_i} = \frac{\Delta p}{n_i} \quad (12)$$

and where Δn , Δp are the concentrations of excess carriers assumed to be equal to each other and constant in the semiconductor surface region. Such conditions occur when minority carrier diffusion length is greater than space charge region width and when quasi-Fermi levels are flat in the semiconductor surface region, i.e. when quasi-equilibrium conditions prevail in MOS structure under illumination. If this can be assumed the values of u_F^* and n_i^* do not depend on the band curvature, and they can be considered as parameters describing properties of semiconductor surface region under given illumination conditions. The assumptions adopted in this theory were formulated and verified in [22, 23]. All these assumptions are fulfilled in the conditions under consideration.

The value of u_F^* can be calculated from the MOS capacitance C_{min} under illumination in the strong inversion conditions (per unit area), by solving the following equation [22, 23] :

$$\frac{1}{C_{min}} = \frac{1}{C_i} + \frac{1}{\epsilon_s} \sqrt{\frac{4 \epsilon_s kT |u_F^*|}{q^2 N}} \quad (13)$$

where ϵ_s is the semiconductor permittivity, q is the electronic charge and N stands for the dopant concentration.

Having found u_F^* , the effective level of light-induced generation ξ can be evaluated from equation (10). Inserting the value of ξ into equation (11) the effective intrinsic concentration n_i^* can be calculated.

Thus, for the illuminated MOS capacitor, the total charge Q_s^* in the semiconductor surface region may be calculated from the following equation :

$$Q_s^* = 2 q n_i^* L_D^* F_s(u_s, u_F^*) \quad (14)$$

where L_D^* is the intrinsic Debye length under illumination conditions

$$L_D^* = \sqrt{\frac{kT \epsilon_s}{2 q^2 n_i^*}} \quad (15)$$

where k is Boltzmann constant, T is temperature, and the Kingston function F_s is given by (4) :

$$F_s = - \frac{u_s}{|u_s|} [e^{-u_F^*}(e^{u_s} - u_s - 1) + e^{u_F^*}(e^{-u_s} + u_s - 1)]^{1/2} \quad (16)$$

where

$$u_s = \frac{q\phi_s}{kT} \quad \text{and} \quad u_F^* = \frac{q}{kT} \phi_F^*$$

3.4 DETERMINATION OF ϕ_{MS} FROM THE V_{GO} AND V_{FB} VALUES. — Two situations, illustrated in figure 5 will be considered now. The first situation (Fig. 5a) is the flat band situation in the semiconductor, meaning that $\phi_s = 0$, in which case

$$V_G = V_{FB} = \phi_{i0} + \phi_{MS} \quad (17)$$

where $\phi_{i0} = \phi_i(\phi_s = 0)$.

The value of ϕ_{i0} may be expressed as :

$$\phi_{i0} = - \frac{Q_{eff}}{C_i} \quad (18)$$

Substituting equation (18) into equation (17), yields the expression for the flat band voltage V_{FB} , given by equation (3).

The second situation of interest (Fig. 5b) takes place when the potential drop across the insulating layer equals zero ($\phi_i = 0$). In this case :

$$V_G = V_{GO} = \phi_{s0} + \phi_{MS} \quad (19)$$

where $\phi_{s0} = \phi_s(\phi_i = 0)$.

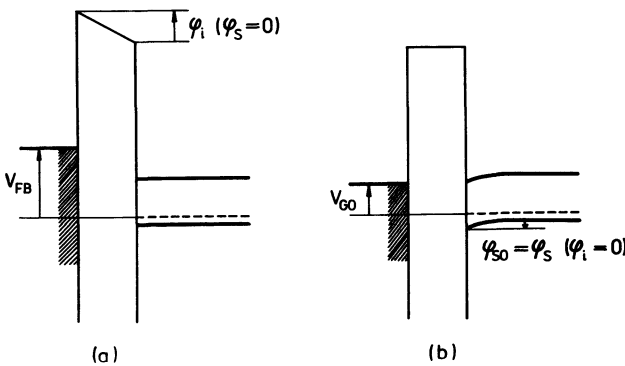

Fig. 5. — The energy band diagrams of the MOS structure at two different gate voltages : a) $V_G = V_{FB}$ (i.e. $\phi_s = 0$); b) $V_G = V_{GO}$ (i.e. $\phi_i = 0$).

(4) The quantities $\phi_F, u_F, n_i, L_D, Q_s$ for illumination conditions are denoted here by symbols with asterisks.

In this situation, the total charge in the semiconductor surface region $Q_s^*(\phi_{s0})$ exactly balances the effective charge of the insulating layer Q_{eff} :

$$Q_{eff} = - Q_s^*(\phi_{s0}) \quad (20)$$

and is given by Kingston formula, for the illumination conditions given by equation (14).

The difference between equation (19) and equation (3) is given by :

$$V_{GO} - V_{FB} = \phi_{s0} + \frac{Q_{eff}}{C_i} \quad (21)$$

or keeping in mind that $Q_{eff} = - Q_s^*(\phi_{s0})$ by the following equation

$$V_{GO} - V_{FB} = \phi_{s0} - \frac{Q_s^*(\phi_{s0})}{C_i} \quad (22)$$

It is interesting to note, that the value of $V_{GO} - V_{FB}$ difference depends on the value of Q_{eff} , but does not depend on ϕ_{MS} .

Substituting equations (14-16) into equation (22) the value of ϕ_{s0} can be calculated provided that V_{GO}, V_{FB} (5) and also u_F^* and n_i^* have been previously determined. Having found ϕ_{s0} the value of ϕ_{MS} can be calculated from equation (9), and the value of Q_{eff} from equations (14-16) and (20) (6).

3.5 DETERMINATION OF ϕ_{MS} FROM V_{GO} AND $C(V_{GO})$ VALUES. — The value of ϕ_{s0} can be found by measuring the capacitance of the MOS structure at V_{GO} gate voltage and using the well known relation between surface potential and capacitance of the semiconductor surface region [3, 4]. In this case u_F^* instead of u_F and n_i^* instead of n_i should be inserted into the expression for the Kingston function as given by equation (16).

In the majority of cases, however, significant simplification of the calculations can be made.

In some structures (e.g. typical Al-SiO₂-Si (p-type) system) V_{GO} lies in the depletion or inversion range, and in such cases the following simplified relation can usually be applied [22, 23] :

$$\phi_{s0} = \frac{\epsilon_s q N}{2[C_s(V_{GO})]^2} \quad (23)$$

where $C_s(V_{GO})$ is the capacitance of the semiconductor surface region (per unit area).

When the value of V_{GO} lies in the accumulation range (e.g. for typical Al-SiO₂-Si (n-type) system),

(5) The simplest and most reliable way to measure V_{FB} is the standard method of $C(V)$ characteristics [3, 4], although other methods [24, 25] can also be used.

(6) Simple programs have been developed for hand-held programmable calculators allowing calculation of ϕ_{s0}, Q_{eff} and ϕ_{MS} for MOS systems of known values of V_{GO} and V_{FB} , substrate doping, and dielectric capacitance.

the simplified relation between $C_s(V_{GO})$ and u_{so} is given by :

$$C_s(V_{GO}) = \sqrt{\frac{\epsilon_s q^2 N}{2 kT}} \frac{e^{u_{so}} - 1}{(e^{u_{so}} - u_{so} - 1)^{1/2}} \quad (24)$$

This equation can be solved numerically for u_{so} .

The capacitance of the semiconductor surface region $C_s(V_{GO})$ can be obtained from the high-frequency $C(V)$ characteristics of MOS capacitor under consideration, using the formula :

$$C_s(V_{GO}) = \frac{C_i \cdot C(V_{GO})}{C_i - C(V_{GO})} \quad (25)$$

where $C(V_{GO})$ is the MIS capacitance at V_{GO} , per unit area.

Following ϕ_{so} calculation, the value of ϕ_{MS} can be calculated using equation (9) and the value of Q_{eff} can be calculated from equations (14-16) and (20).

4. Experimental. — In our experiments, the measurements consisted usually of the following steps :

1. Measurement of the insulating layer thickness x_i , by ellipsometric methods.

2. Taking of the « primary », dark, high-frequency $C(V)$ characteristic of the measured MOS structure, from strong accumulation to strong inversion, and taking of the same characteristic in expanded scales to get more precision in reading the V_{FB} value.

3. Measurement of the MOS capacitance in strong inversion under UV illumination (the wavelength $\lambda = 260$ nm was used).

4. Determination of the $V_G = V_{GO}$ value, under UV illumination, at which the gate-substrate current goes through zero, and measurement (at the same gate voltage) of the capacitance $C(V_{GO})$ of the illuminated MOS.

5. Taking of the « secondary », dark, high-frequency $C(V)$ characteristic in expanded scales in order to determine the V_{FB} value.

Processing of the measurement results, and calculation of the ϕ_{MS} value was usually pursued in following steps :

1. From the $C(V)$ characteristics (taken in step 2 above) the MOS capacitances C_{max} (in strong accumulation) and C_{min} (in strong inversion) are read, from which the doping density N , the dielectric capacitance C_i , and the flat band capacitance C_{FB} are calculated by standard methods [3, 4], using the previously determined value of the dielectric thickness x_i (step 1 above).

2. The value of MOS capacitance in strong inversion under UV illumination (obtained in step 3 above) is used to calculate the values of ϕ_F^* , and n_i^* (see section 3.3).

3. The values of V_{GO} (obtained in step 4 above), and V_{FB} read from the « secondary » $C(V)$ characteristic (taken in step 5 above), and also the values of u_F^*

and n_i^* are used to calculate ϕ_{so} from equation (22). This allows further calculation of Q_{eff} , and ϕ_{MS} using equations (14-16), and (9). This procedure of ϕ_{MS} determination is called « Method I », and the results are labelled accordingly.

4. The value of $C(V_{GO})$ (obtained in step 4 above) is used to calculate $C_s(V_{GO})$ from equation (25), and ϕ_{so} from (23) or (24) as discussed in section 3.5. This again allows calculation of Q_{eff} , and ϕ_{MS} using equations (14-16) and (9). This procedure of ϕ_{MS} determination is called « Method II » and the results are labelled accordingly.

The values of ϕ_{MS} have been measured for three groups of different Al-SiO₂-Si samples :

— Group VX 28 consisted of MOS samples manufactured using p-type 8.3 Ω .cm resistivity silicon substrates of $\langle 100 \rangle$ orientation, which were oxidized in a « wet » oxidation atmosphere (O₂ + H₂O) (7) at temperature $T = 1000$ °C, to obtain SiO₂ layers of thickness $x_i = 193$ nm.

— Group VX 25 consisted of MOS samples made on the same type and orientation of the substrates, which were oxidized in « dry » ambient (O₂), at temperature $T = 1100$ °C, to obtain $x_i = 198$ nm.

— Group VX 13 consisted of MOS samples made on n-type, 4.8 Ω .cm resistivity silicon substrates of $\langle 111 \rangle$ orientation, oxidized in dry O₂ atmosphere at $T = 1100$ °C, to obtain $x_i = 207$ nm.

Formation of Al gate electrodes for all groups of samples, was made by two step EB blanket evaporation, and standard photolithographic techniques. In the first step, small (0.5 mm \times 0.5 mm) and thick ($x_{Al} = 1$ μ m) Al contact pads are formed, while in the second step larger (1.5 mm \times 1.5 mm) semi-transparent ($x_{Al} = 10$ nm) aluminum gates (covering the previously made contact pads) are formed. The remaining processes used in preparation of these groups of samples were made according to the standard procedures used in manufacturing of MOS integrated circuits. Special measures were taken to assure that these processes are identically conducted for all the groups of samples. All the three groups of samples received 15 min. final anneal in pure nitrogen atmosphere at 500 °C.

Between 20 and 40 samples were measured for each group. The measurement results are summarized in table I where average values, and standard deviations are given for the parameters determined by both methods described above.

5. Discussion. — The dispersion of ϕ_{MS} and Q_{eff} values obtained for one run of identically processed MOS structures is small as seen from the values of standard deviations (see Table I).

The differences between the average values of ϕ_{MS}

(7) No Cl containing agents have been added to the oxidation atmospheres used in these experiments.

Table I. — Summary of measurement results and calculations performed using Method I and Method II. Average values, and standard deviations are given for the surface potential ϕ_{so} , effective charge of insulating layer Q_{eff}/q and contact potential difference ϕ_{MS} .

		VX 28 p-Si < 100 > wet oxide $\phi_F = 0.301$ V		VX 25 p-Si < 100 > dry oxide $\phi_F = 0.301$ V		VX 13 n-Si < 111 > dry oxide $\phi_F = -0.290$ V	
		Average value	Std. dev.	Average value	Std. dev.	Average value	Std. dev.
Method I	ϕ_{so} (V)	0.134	0.019	0.065	0.006	0.114	0.002
	Q_{eff}/q (cm^{-2})	4.88×10^{10}	4.30×10^9	2.92×10^{10}	2.00×10^9	1.66×10^{11}	3.53×10^9
	ϕ_{MS} (V)	-0.555	0.026	-0.542	0.012	-0.105	0.019
Method II	ϕ_{so} (V)	0.114	0.017	0.060	0.006	0.118	0.002
	Q_{eff}/q (cm^{-2})	4.40×10^{10}	4.19×10^9	2.81×10^{10}	2.03×10^9	1.79×10^{11}	1.04×10^{10}
	ϕ_{MS} (V)	-0.536	0.029	-0.537	0.013	-0.108	0.021

obtained by Method I and Method II, are small, and are due to the differences in ϕ_{so} values obtained by both methods.

The obtained values of ϕ_{MS} seem to be « reasonable » when compared with the values given by other authors, as shown in figure 3. The values of Q_{eff}/q follow the well known dependences on substrate orientation and oxidation conditions (see e.g. [13]), which is an additional proof that both methods yield correct results. It is worthwhile to note that the difference between the average values of ϕ_{MS} obtained (with both methods) for VX 28 samples (wet oxidation) and VX 25 samples (dry oxidation) is statistically insignificant, at a significance level of 5 %, which suggests that the « wetness » of the oxidation atmosphere does not significantly affect ϕ_{MS} values of the samples. It should however be noticed that the dispersion of measurement results is significantly higher for VX 28 samples (wet oxidation) than for the VX 25 samples (dry oxidation).

One of the more important observations made in the course of these measurements is that the value of ϕ_{MS} of a given MOS sample is changed slightly ($\Delta\phi_{MS} = 20$ mV-50 mV) by the measurement procedure itself. This means, that for several consecutive measurements made on the same sample, one gets higher and higher values of ϕ_{MS} (or less and less

negative values of ϕ_{MS}), which is not accompanied by significant changes in Q_f values. This effect was proved to be due to the UV illumination used for V_{GO} measurement, and we attribute it to trapping of electrons excited into the SiO_2 conduction band. The observed trend of ϕ_{MS} changes and small values of the observed changes of Q_{eff} suggest that electron trapping in the neighbourhood of the Al- SiO_2 interface predominates — increasing thus the potential barrier height at the Al- SiO_2 interface. This was confirmed by an independent measurement of Al- SiO_2 , and Si- SiO_2 barrier height changes introduced by UV illumination [26] (The Powell-Berglund method of barrier height determination was used [27, 28]).

Preliminary results of experiments with heat treatment of the previously UV illuminated MOS structures show that electrons trapped in SiO_2 , may be released in a low temperature heat treatment, such as the final anneal applied in preparation of our samples (see section 4). Thus, it seems that using different combinations of processes which promote trapping or detrapping (or more generally introduction or extraction) of charges in the neighbourhood of Al- SiO_2 , and/or Si- SiO_2 interfaces, a wide range of ϕ_{MS} values may be obtained. This, was probably the main reason for the differences in ϕ_{MS} values obtained by various authors (see Fig. 3). Further work is necessary to fully explain the influence of charge trapping on the values of ϕ_{MS} , and the values of various charges in SiO_2 .

Assuming that the UV illumination influences ϕ_{MS} and does not influence Q_{eff} , the values of ϕ_{MS} obtained in this work (and given in table I), should be corrected for the shift caused by UV illumination. Since in our case the average value of V_{FB} shift was $\Delta V_{FB} = 0.035$ V, the values of ϕ_{MS} of the original samples (before the measurement) used in our experiments, should be 0.035 V lower (more negative) than the values given for them in table I. The results of our measurements shown in figure 3 are corrected accordingly.

6. **Conclusions.** — 1. Two new techniques for CPD determination in MOS structures have been developed. These techniques were applied in practice yielding ϕ_{MS} values remaining in close agreement with each other, and within the range of ϕ_{MS} values obtained by other authors.

2. These techniques are simple and much easier in application than the commonly used methods of ϕ_{MS} determination. In particular, only one MOS capacitor is required for measurement of one ϕ_{MS} value (as opposed to a series of MOS capacitors with different thicknesses of the dielectric layer required for the application of the classical method).

3. The dispersion of ϕ_{MS} and Q_{eff} values obtained for one run of identically processed MOS structures is small.

4. The accuracy of ϕ_{MS} determination seems to be good in spite of the fact that the measurement tech-

nique itself introduces a slight change in the ϕ_{MS} value.

5. Changes of the value of CPD in Al-SiO₂-Si structures were observed to occur as a result of charge trapping and detrapping in SiO₂. In particular, trapping of electrons in the neighbourhood of the Al-SiO₂

interface, caused by UV illumination of the sample was shown to change the value of ϕ_{MS} .

Further work is needed for better understanding of these phenomena, and their importance for the MOS technology.

References

- [1] HERRING, C., NICHOLS, M. H., *Thermionic emission. Rev. Mod. Phys.* **21** (1949) 185.
- [2] HÖLTZL, J., SCHULTE, F. K., *Work function of metals. In : Solid Surface Physics* (Springer Tracts in Modern Physics) Vol. **85**, Berlin (1979).
- [3] GROVE, A. S., *Physics and Technology of Semiconductor Devices* (J. Wiley and Sons, New York) 1967.
- [4] SZE, S. M., *Physics of Semiconductor Devices* (J. Wiley and Sons, New York) 1969.
- [5] DEAL, B. E., SNOW, E. H., MEAD, C. A., Barrier energies in metal-silicon dioxide-silicon structures. *J. Phys. Chem. Solids* **27** (1966) 1873.
- [6] WERNER, W. M., The work function difference of the MOS system with aluminium field plates and polycrystalline silicon field plates. *Solid-State Electron.* **17** (1974) 769.
- [7] KAR, S., Determination of Si-Metal work function differences by MOS capacitance technique. *Solid-State Electron.* **18** (1975) 169.
- [8] HABERLE, K., FRÖSCHLE, E., On the work function difference in the Al-SiO₂-Si system with reactively sputtered SiO₂. *J. Electrochem. Soc.* **126** (1979) 878.
- [9] GAIND, A. K., KASPRZAK, L. A., Determination of distributed fixed charge in CVD oxide and its virtual elimination by use of HCl. *Solid-State Electron.* **22** (1979) 303.
- [10] HICKMOTT, T. W., Dipole layers at the metal-SiO₂ interfaces. *J. Appl. Phys.* **51** (1980) 4269.
- [11] DEAL, B. E., Standardized terminology for oxide charges associated with thermally oxidized silicon. *J. Electrochem. Soc.* **127** (1980) 979.
- [12] AGAJANIAN, A. H., A bibliography on silicon dioxide films. SCP and *Solid State Technol.* **20** (1977) 36.
- [13] DEAL, B. E., Charge effects and other properties of the Si-SiO₂ interface. The current understanding. Proc. of the III International Symposium on Silicon Materials Science and Technology. Philadelphia Pa. May 8-13, 1977.
- [14] PRZEWŁOCKI, H. M., KRAWCZYK, S., JAKUBOWSKI, A. A new technique for accurate determination of work function difference in MOS structures. 10th European Solid State Device Research Conference and 5th Symposium on Solid State Device Technology. York, England, September 1980.
- [15] PRZEWŁOCKI, H. M., KRAWCZYK, S., JAKUBOWSKI, A. A simple technique of work function difference determination in MOS structures. *Phys. Status Solidi (a)* **65** (1981) 253.
- [16] PRZEWŁOCKI, H. M., Investigation of the influence of technology on Si-SiO₂ system and MOS structure electrical properties. *Electron Technology* **3** (1970) 103.
- [17] VISWANATHAN, C. R., OGURA, S., Direct measurement of built in voltage in MOS structures. *J. Appl. Phys.* **42** (1971) 5865.
- [18] GROSVALET, J., Influence of illumination on MIS capacitance in the strong inversion region. *IEEE Trans. Electron. Devices* **ED-14** (1967) 777.
- [19] PIERRET, R. H., SAH, C. T., Quantitative analysis of the effects of steady state illumination on the MOS capacitor-theory. *Solid-State Electron.* **13** (1970) 269.
- [20] PIERRET, R. H. and SAH, C. T., Quantitative analysis of the effects of steady state illumination on the MOS capacitor-experiment. *Solid-State Electron.* **13** (1970) 289.
- [21] TEMPLE, V. and SCHEWCHUN, J., Exact frequency dependent complex admittance of the MOS diode including surface states, SRH impurity effects and low-temperature dopant impurity response. *Solid-State Electron.* **16** (1973) 93.
- [22] JAKUBOWSKI, A. and KRAWCZYK, S., Electrical properties of MIS capacitor under illumination. *Electron Technology* **11** (1978) 3.
- [23] KRAWCZYK, S., Analysis of photoelectric properties of a metal-insulator-semiconductor (MIS) capacitor, Ph. D. Thesis, Dept. of Electronics, Technical University of Warsaw (1980).
- [24] YUN, B. H., Direct measurement of flat-band voltage in MOS by infrared excitation. *Appl. Phys. Lett.* **21** (1972) 194.
- [25] JAKUBOWSKI, A., KRAWCZYK, S., Photoelectric method of the MIS flat band voltage determination. *Electron Technology* **11** (1978) 23.
- [26] LIBERADZKA, M., GRABSKI, J., private communication.
- [27] POWELL, R. J., Interface barrier energy determination from voltage dependence of photoinjected currents. *J. Appl. Phys.* **41** (1970) 2424.
- [28] BERGLUND, C. N., POWELL, R. J., Photoinjection into SiO₂ : Electron scattering in the image force potential well. *J. Appl. Phys.* **42** (1971) 573.