



HAL
open science

NUCLEATION AND CRYSTAL GROWTH IN SOFT-SPHERE SYSTEMS

G. Bushnell-Wye, J. Finney

► **To cite this version:**

G. Bushnell-Wye, J. Finney. NUCLEATION AND CRYSTAL GROWTH IN SOFT-SPHERE SYSTEMS. Journal de Physique Colloques, 1985, 46 (C3), pp.C3-311-C3-321. 10.1051/jphyscol:1985325 . jpa-00224642

HAL Id: jpa-00224642

<https://hal.science/jpa-00224642>

Submitted on 4 Feb 2008

HAL is a multi-disciplinary open access archive for the deposit and dissemination of scientific research documents, whether they are published or not. The documents may come from teaching and research institutions in France or abroad, or from public or private research centers.

L'archive ouverte pluridisciplinaire **HAL**, est destinée au dépôt et à la diffusion de documents scientifiques de niveau recherche, publiés ou non, émanant des établissements d'enseignement et de recherche français ou étrangers, des laboratoires publics ou privés.

NUCLEATION AND CRYSTAL GROWTH IN SOFT-SPHERE SYSTEMS

G. Bushnell-Wye and J.L. Finney

*Department of Crystallography, Birkbeck College, Malet Street,
London WC1E 7HX, U.K.*

Résumé - Partant d'une configuration amorphe modélisée, de 4000 "sphères-molles", une méthode de dynamique moléculaire permet d'illustrer la germination spontanée. L'analyse du processus de cristallisation, à trois étapes de la simulation, à l'aide des indices des polyèdres de Voronoï montre que des germes bcc et fcc continuent à croître. Des ambiguïtés dans la structure, apparaissant pour certains types d'indices, peuvent être levées en utilisant des méthodes graphiques numériques. Certaines de ces figures donnent l'impression d'un changement de phase localisé d'une structure bcc en fcc, ceci demandant à être confirmé expérimentalement.

Abstract - Spontaneous homogeneous nucleation can be demonstrated in a model of 4000 soft-spheres annealed from an amorphous starting configuration via a molecular dynamics method. Analysis of the crystallisation process at three stages of the simulation using Voronoi polyhedra indices shows that both bcc and fcc nuclei continue to grow. Methods of delineating the nuclei and the effects on their resulting shape and size are discussed, and it is shown how ambiguities in structure which arise both for particular index types and local arrangements can be resolved using computer graphics techniques. Some of the drawings displayed give the impression of localised phase change from bcc to fcc structure though these events have yet to be confirmed.

1. INTRODUCTION

In computer simulation of supercooled liquids it is relatively easy to ensure that foreign bodies are excluded and (using suitable periodic boundary conditions) that there are no container walls, thereby providing an environment conducive to homogeneous nucleation rather than heterogeneous nucleation which is more probable in nature. Even so, it will not occur without further ensuring that the temperature and density of the ensemble present no barriers to nucleation. In the absence of heterogeneous substrates, local inhomogeneities occur by chance fluctuations in structure and these can form the bases of nucleation. In the small systems first studied, crystalline structures formed only under the influence of boundary conditions. More recently it has been demonstrated that the phenomenon of spontaneous homogeneous nucleation can occur in a supercooled Lennard-Jones liquid provided there are no barriers to nucleation (Mandell, McTague and Rahman (1976)). Molecular dynamics calculations on a system of 4000 soft-spheres (Cape,

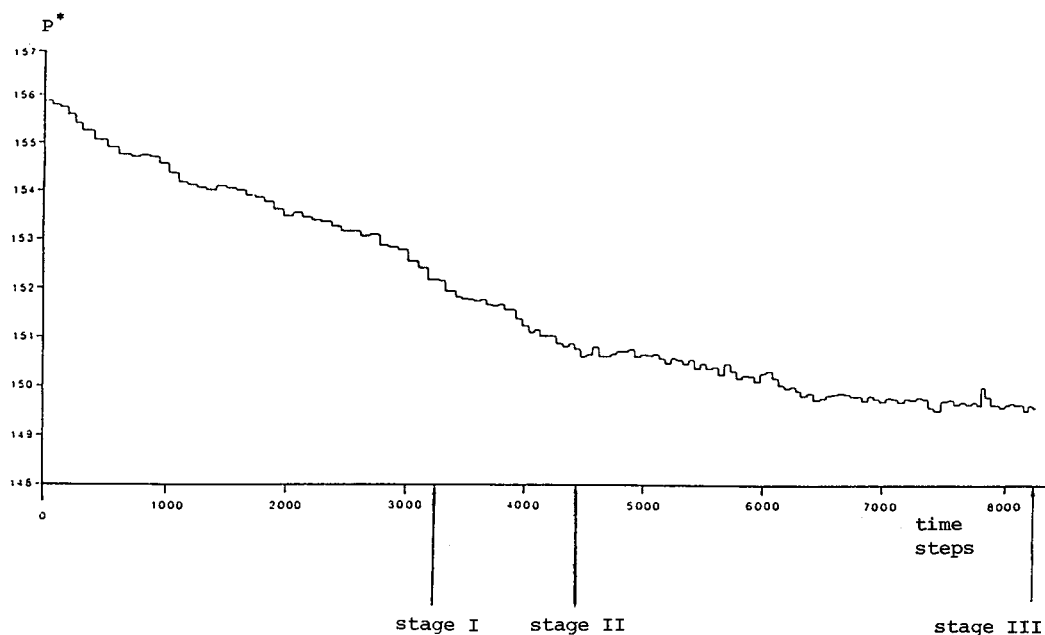

Figure 1. The variation of the reduced pressure, P^* during the course of the molecular dynamics simulation. The average values for each 50 time steps are plotted.

2. STRUCTURE CHARACTERISATION

The problem of identifying order within the system is essentially to locate nuclei within a fluid of much the same density, which is difficult unless a nucleus is large and well defined. It can be done by calculating a structure factor for specific lattice vectors (see for example Mandell et al (1976)) but the results can be misleading and may not distinguish between bcc and fcc structure (Hsu and Rahman (1979)). The method adopted in these investigations was that employing the 'indices' of the Voronoi polyhedra which can be constructed to enclose all space closest to each atom within the system providing a complete statistical characterisation (Finney (1970)). Each index $(n_3, n_4, n_5, n_6, \dots)$ lists the number of faces, n_j having a total of j edges, ('trailing zeros being suppressed after $j = 6$), thus a perfect bcc structure would generate indices of (0 6 0 8) only (figure 2).

A fundamental difficulty arises, however, when attempting to uncover the presence of crystalline close-packed structures. Under ideal conditions, having no thermal fluctuations, these would give rise to indices (0 12 0 0) for both bcc and hcp arrangements (see figure 2). With even the slightest disturbance the degenerate vertices formed at the intersections of four edges in these polyhedra (so called because any three of the four edges define the vertex - figure 2) separate into two or more vertices at junctions of three edges and additional faces may arise. Consequently the indices are easily distorted and confusion results.

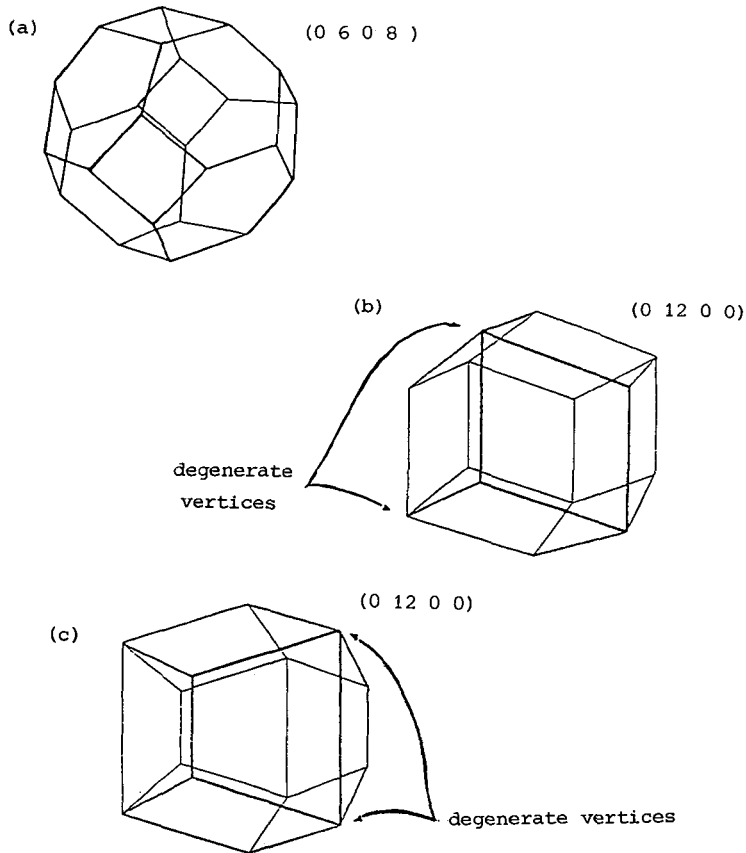

Figure 2. Polyhedra for perfect (a) bcc, (b) fcc, and (c) hcp structures. Some degenerate vertices (intersections of four edges) are indicated in (b) and (c).

The use of time averaged coordinates (averaged over 100 time steps) does not improve the situation (Cape(1979)). It is possible to reveal the underlying close-packed crystal structure by merging vertices closer than a distance ζ (i.e. removing short edges) so creating the ideal polyhedra from the distorted versions. For this procedure to be useful a value of ζ is chosen to be commensurate with the thermal fluctuation η and the inter-neighbour distance d . Hsu and Rahmann (1979) have demonstrated the effectiveness of this method for Lennard-Jones systems and models of supercooled metals. A similar estimation of the parameters appropriate for this soft-sphere system gave $\eta/d = 0.09$, suggesting $\zeta/\eta = 3$ should be used when modifying the polyhedra to indicate the present of fcc (or hcp) nuclei. ($d \sim 0.077\lambda$; η is estimated from the mean square displacement of the

atoms and is $\sim 0.007\lambda$, giving $\zeta = 0.02\lambda$ where $\lambda = \sqrt[3]{V/N}$). This was in agreement with a series of tests to determine the value of ζ empirically for a region at stage I previously identified as being the largest fcc nucleus (Cape et al (1981)). These tests indicated maximum resolution of fcc structure occurred for $\zeta = 0.025\lambda$. It was apparent that some polyhedra for atoms in a bcc nucleus were also modi-

fied to become (0 12 0 0) - type when using this procedure. This emphasized at an early stage that ambiguities could arise owing to minor differences between distorted bcc and distorted fcc polyhedra, and that it would be necessary to draw some of the polyhedra to resolve the problem.

The central region of the model, some 2200 atoms, was investigated at each of the stages defined above using both modified and unmodified indices. The proportions of bcc and fcc polyhedra at each stage are shown in table 2. It appears that the number of local bcc arrangements increases but remains the same between stages II and III whereas the fcc (and/or hcp) clusters increases throughout the simulation.

Table 2 : Percentage of (0 6 0 8) polyhedra found before modification and the percentage of (0 12 0 0) polyhedra found after modification (expressed as a percentage of the total number of polyhedra)

Stage	% (0 6 0 8)	% (0 12 0 0)
	unmodified polyhedra	modified polyhedra
I	7.4	15.6
II	11.6	22.5
III	11.6	27.1

3. DELINEATING THE NUCLEI

It is possible to investigate the extent (and perfection) of bcc nuclei by listing all unmodified polyhedra of type (0 6 0 8) and checking which of these have neighbours at or about the right distance and in the right directions to form bcc aggregates (Cape et al (1981)), though this can be a laborious task. Similarly, the four interpenetrating simple cubic lattices of fcc crystallites could be mapped using the modified polyhedra of type (0 12 0 0) as a guide. However, since a computer can access all the data required, it is a less arduous job to write computer programs to do this: neighbouring polyhedra of similar type, irrespective of distance and direction criteria, can be readily tabulated and then lists can be compiled of those forming separate groups or nuclei (Bushnell-Wye (1983)). It is important to recognise that some atoms on the surface of the nuclei may well be in exact register with the nucleus but, because of their disorganised neighbours away from the nucleus, they will not have the requisite indices (even when modified). Such atoms should be included in the description of the extent of the nuclei but not to connect neighbouring nuclei, otherwise the nuclei become very dendritic.

Using distance and direction criteria to specify nucleus size limits nuclei to the nearly perfectly crystalline regions and probably underestimates their size though their shapes tend to be fairly globular. Disregarding such criteria results in larger nuclei (in general) which have ramifications into less perfectly organised regions of the model.

4. RESULTS

Tables 3 and 4 show the sizes of the larger nuclei found at each of the stages analysed and emphasize how the assigned size is influenced by

Table 3. The sizes of the larger bcc nuclei identified at each stage both with and without surface contributions.

	Stage I		Stage II		Stage III	
	(0 6 0 8)	(0 6 0 8) + surface atoms	(0 6 0 8)	(0 6 0 8) + surface atoms	(0 6 0 8)	(0 6 0 8) + surface atoms
Number of atoms in nuclei of 10 or more atoms						
nucleus 1	19	97	45	239	43	216
2	14	81	41	192	34	195
3	11	61	35	180	30	138
4			28	141	17	97
5					11	76
6					11	66
7					11	61

Table 4. The sizes of the larger fcc nuclei identified at each stage both with and without surface contributions.

	Stage I		Stage II		Stage III	
	(0 12 0 0)	(0 12 0 0) + surface atoms	(0 12 0 0)	(0 12 0 0) + surface atoms	(0 12 0 0)	(0 12 0 0) + surface atoms
Number of atoms in nuclei of 10 or more atoms						
nucleus 1	151	598	324	1227	405	1519
2	32	139	61	280	121	469
3	30	171	22	104		
4	10	59				
5	10	56				

the inclusion of surface atoms. The true size almost certainly lies somewhere between the two totals given for each nucleus. Comparing the totals for each stage suggests that the bcc nuclei grow to begin with but then remain much the same size whereas the fcc clusters continuously increase in size perhaps by merging with neighbouring clusters. It is obvious that some ambiguities arise in defining both local symmetry and the extent of ordered groups, and that the only way to resolve the problem is to examine some groups in detail. An interactive computer graphics system has been used to draw both individuals and small clusters of polyhedra; some drawings are presented here to demonstrate the results of the analysis so far. Figure 3 shows polyhedra for two (0 6 0 8) atoms before and after modification to remove short edges. Clearly, some (0 6 0 8) environments are very close to being ideal fcc structures while others are not which suggests incorrect assignments could be made using unmodified polyhedra indices alone. Extended regions of bcc and fcc character also exist as depicted in the clusters of figure 4. Highlighted in figure 5 is the type of feature which can occur both in real structures and in this soft-sphere model. These can only be allowed to exist in the latter if strict distance and direction criteria are not used in defining the extent of crystalline close-packed regions: stacking faults introduce lattice translations and therefore form a boundary to a nucleus if it is only

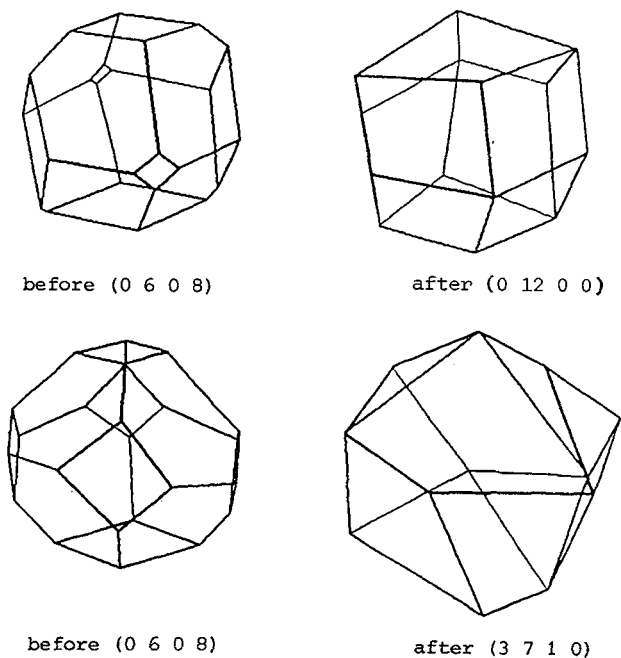

Figure 3. Two polyhedra having unmodified index (0 6 0 8) but clearly different environments. (a) The modified index (0 12 0 0) shows that the symmetry of the atoms' neighbours is very nearly fcc. (b) The modified polyhedron index (3 7 1 0) does not express a high symmetry whereas the drawing of the unmodified form has distinct bcc symmetry.

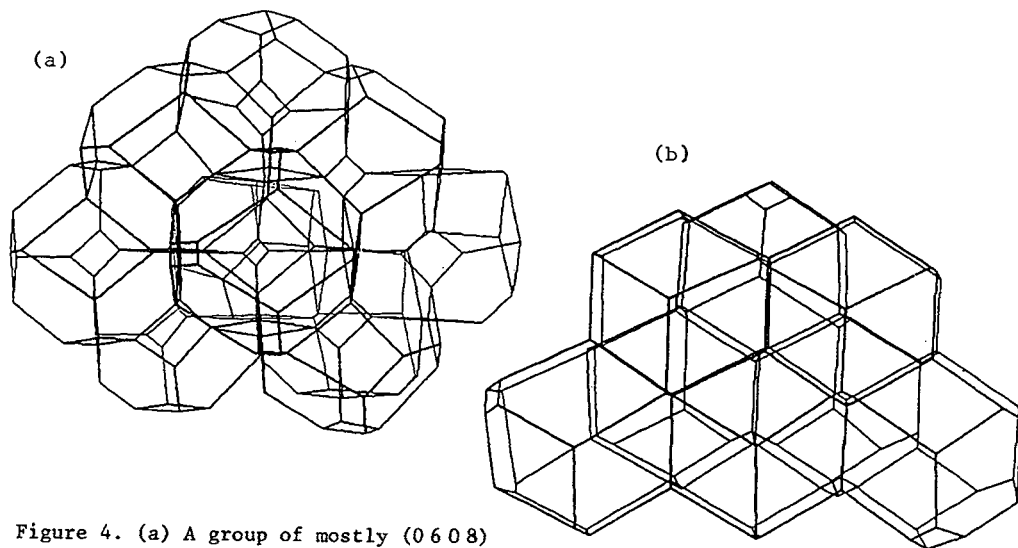

Figure 4. (a) A group of mostly (0 6 0 8) polyhedra with strong bcc character. (b) A group containing some (0 6 0 8) polyhedra having strong fcc character.

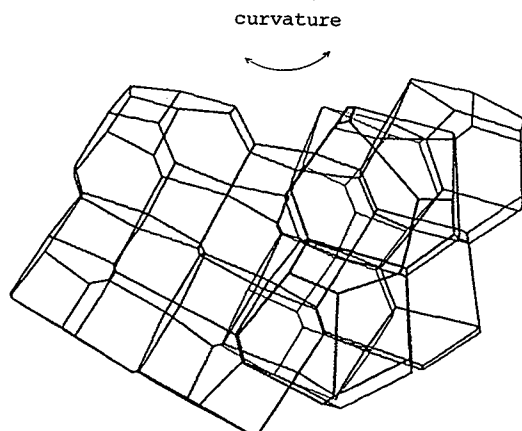

Figure 5. A stacking fault within a fairly well ordered part of the model. The polyhedra can be compared with those of the perfect fcc and hcp structures.

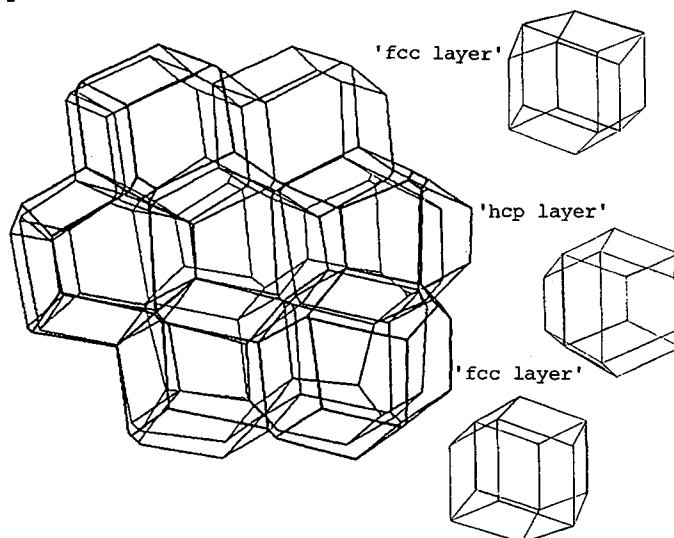

Figure 6. An arrangement of polyhedra suggesting plane curvature. The sense of curvature is indicated. An alternative interpretation is that a grain boundary is being observed.

allowed to have (by definition of the technique used) near perfect structure. Similarly, gross plane curvature, figure 6, and grain boundaries, figure 7, can also be identified in this model.

5. PHASE TRANSFORMATION

When drawing polyhedra, as described above, to examine the structure associated with particular indices there were often polyhedra which exhibited both fcc and bcc character. Sometimes this was due to the small size of the six quadrilateral faces of a (0 6 0 8) polyhedron and in other cases one 'half' of the polyhedron could be recognised as

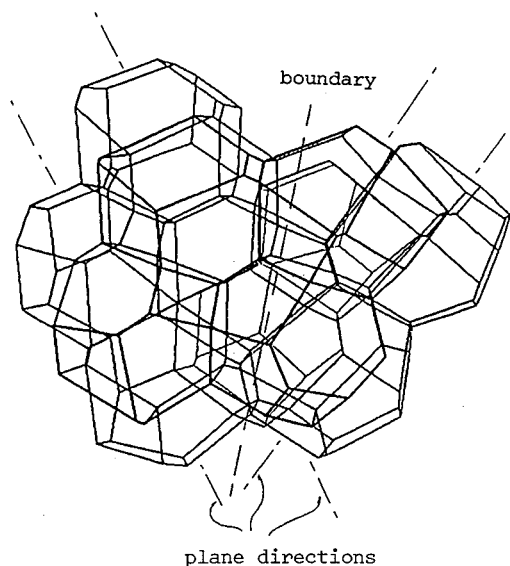

Figure 7. An arrangement of polyhedra suggesting the existence of a grain boundary.

having strong bcc characteristics and the other was very nearly perfect fcc-type. Once again, these features could not be identified from indices alone, making the use of the graphics essential. The overall impression suggested a change of phase from bcc to fcc was occurring. Reference to table 2 and maps detailing the distribution of index types throughout the system (not shown here) at each of the three stages analysed does not support this however, but rather suggests that nuclei grow by expanding into regions having indistinct crystalline character. Further analysis at different stages in the simulation must be undertaken to ascertain exactly what transformations are taking place within the ensemble.

It is possible to construct hypothetical intermediate stages of transformation from a polyhedron of type $(0\ 6\ 0\ 8)$ to one of type $(0\ 12\ 0\ 0)$, and some of the features of the intermediate stages could be seen in polyhedra displayed using the graphics programs. An example of this is the unmodified $(0\ 4\ 4\ 4)$ polyhedron in figure 8. Even though only slight movement of neighbours would be required to make this into a $(0\ 12\ 0\ 0)$ -type polyhedron, it is easy to see that large cooperative movements would be required to effect such a transformation over a large number of neighbours: the cooperative movements shown in fig.8 could not possibly occur owing to the constraints of the periodic boundary conditions. This type of transformation could therefore only take place with different orientations throughout the model and extensive grain boundaries would result. Further organisation might proceed under thermal fluctuations to allow some grains to grow.

6. CONCLUSIONS

Suitable conditions have been provided for the annealing process in the soft-sphere system to permit spontaneous homogeneous nucleation of both bcc and crystalline close-packed structures. The nuclei grow in the

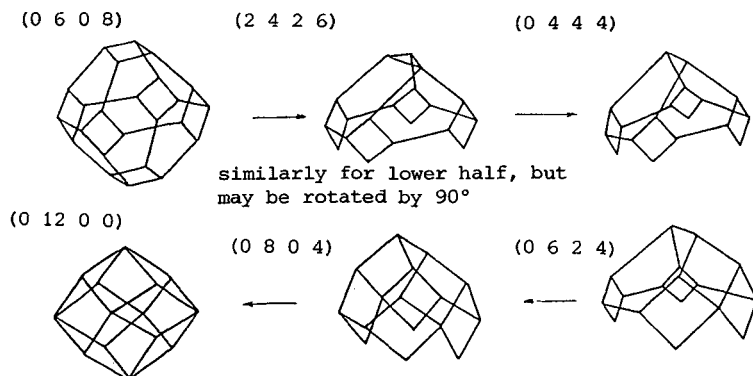

- (a) Successive alterations can be made to transform a polyhedron of index (0 6 0 8) to one of the (0 12 0 0)-type.

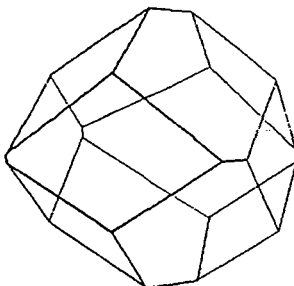

- (b) An unmodified (0 4 4 4) polyhedron taken from the model. Some features of this polyhedron can be seen in the structures in (a). Only minor rearrangements of neighbours would be required to form a fcc polyhedron.

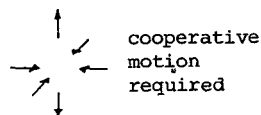
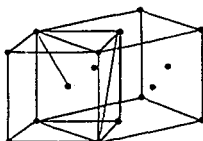

- (c) The relationship between the bcc and fcc lattices is shown together with an indication of the cooperative movements necessary to effect a phase change. A widespread motion of this nature is denied by the periodic boundaries.

Figure 8. The geometry of the bcc to fcc phase transformation.

continued simulation as judged by an increased number of Voronoi polyhedra having indices typical of a crystalline environment. However, the technique used has limitations and it is essential to be aware of the ambiguities which arise. These difficulties can best be sorted out with the aid of computer graphics.

The (0 6 0 8) index can represent strong bcc character but additionally may indicate a distortion of crystalline close-packed symmetry. Modified indices of type (0 12 0 0) occur for either fcc or hcp stacking sequences and can only be distinguished by resorting to geometrical considerations or by drawing the polyhedron concerned. The technique used to delineate the nuclei curtails their size if geometrical constraints are specified; if not, the nuclei can be more nebulous and features such as stacking faults and grain boundaries can

be included in the crystallites. The latter approach seems reasonable because these features would be expected when crystallising rapidly from undercooled liquids. Once again, the uncertainties related to the extent of individual nuclei can only be resolved quickly with the aid of computer graphics.

It is possible that a phase change from bcc to fcc is occurring locally in the model though insufficient evidence has been found to support this. It would not be possible for the whole system to undergo a phase change in the same sense owing to the constraints of the periodic boundaries. Further analysis is required (of small regions of the model) over shorter time intervals to investigate the hypothesis.

REFERENCES

- J. N. Cape, J. L. Finney and L. V. Woodcock (1981), *J.Chem.Phys.*75, 2366
J. N. Cape and L. V. Woodcock (1980), *J. Chem.Phys.*72, 976
J. L. Finney (1970), *Proc.Roy.Soc. London*, A319, 479
J. N. Cape (1979), PhD Thesis, University of Cambridge
C. S. Hsu and A. Rahman (1979), *J. Chem.Phys.* 72, 4974
M. J. Mandell, J. P. McTague and A. Rahman (1976), *J.Chem.Phys.*64, 3699
G. Bushnell-Wye (1983), PhD Thesis, University of London.