



HAL
open science

NEGATIVE ION PRODUCTION IN SURFACE-PLASMA SOURCES WITH UNCLOSED ELECTRON DRIFT DISCHARGES

Yu. Bel'Chenko, V. Dudnikov

► **To cite this version:**

Yu. Bel'Chenko, V. Dudnikov. NEGATIVE ION PRODUCTION IN SURFACE-PLASMA SOURCES WITH UNCLOSED ELECTRON DRIFT DISCHARGES. Journal de Physique Colloques, 1979, 40 (C7), pp.C7-501-C7-502. 10.1051/jphyscol:19797243 . jpa-00219227

HAL Id: jpa-00219227

<https://hal.science/jpa-00219227>

Submitted on 4 Feb 2008

HAL is a multi-disciplinary open access archive for the deposit and dissemination of scientific research documents, whether they are published or not. The documents may come from teaching and research institutions in France or abroad, or from public or private research centers.

L'archive ouverte pluridisciplinaire **HAL**, est destinée au dépôt et à la diffusion de documents scientifiques de niveau recherche, publiés ou non, émanant des établissements d'enseignement et de recherche français ou étrangers, des laboratoires publics ou privés.

NEGATIVE ION PRODUCTION IN SURFACE-PLASMA SOURCES WITH UNCLOSED ELECTRON DRIFT DISCHARGES

Yu. I. Bel'chenko, V.G. Dudnikov.

Institute of Nuclear Physics, Novosibirsk, U.S.S.R.

1. In developed variants of surface-plasma sources /2,3/ the minimum energy necessary for H^- generation is about 10^4 eV/ion. The further increase in efficiency of negative ion generation is desirable for construction of long term operation sources. The most evident way to increase the energy efficiency is the more complete utilization of negative ions emitted from electrodes /2/. In experiments presented here, more complete extraction of generated negative ions was provided with localization of the discharge near the emission slit and with geometrical focusing of negative ions emitted by a half-cylindrical cathode surface to the emission slit.

2. The diagram of the source with discharge location near the emission slit (so-called semiplanotron - SP) is shown in Fig.1.

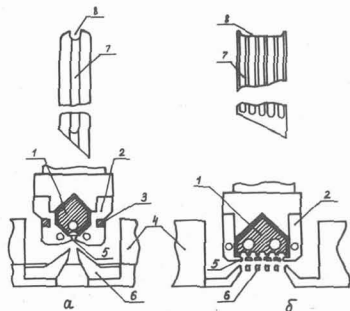

Fig.1 Semiplanotron diagram:

a - with one groove, b - with five grooves; 1 - cathode, 2 - anode, 3 - magnetic inserts, 4 - poles of magnet, 5 - emission slit, 6 - extractor, 7 - cathode groove, 8 - end cathode hollow.

Similar to the planotron /2/, the discharge takes place in a thin gap between the long cathode 1 and anode 2, which embraces the cathode. For the effective

plasma utilization, SP discharge is maintained only in a region near the emission slit. In this place the magnetic field lines are specially bent with magnetic inserts 3. The magnetic field lines two times cross the half-cylindrical cathode surface without crossing the anode, providing conditions for confinement of fast electrons emitted by cathode. These electrons oscillate in the cathode groove and drift along the emission slit sawed perpendicular to magnetic field lines. The deeper hollow 8 is made at one of the cathode end for better discharge triggering. Electromagnetic valve and heated container provide this hollow with hydrogen portions and cesium vapour. For preventing discharge in other parts of the cathode-anode gap, SP electrodes have the special shape preventing electron oscillations in these regions. Electrons in the side gaps fall quickly to the anode along the magnetic field lines. A half-cylindrical shape of the cathode operation surface provides geometrical focusing of negative ions emitted by the surface to emission slit. Extraction voltage of up to 35 kV is applied to discharge chamber, extractor 6 is under ground potential. The pulse mode of such sources was under study. An amplitude of the discharge current pulse was up to 0.2 kA, duration 1 mS, repetition rate up to 10 Hz.

3. The characteristics of high current glow discharge in SP, their dependencies on magnetic field, hydrogen and cesium density, discharge current were similar to those of planotron discharge /2/. The dependencies of extracted H^- and D^- current on discharge current are

given in Fig.2.

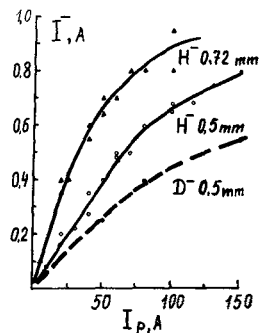

Fig.2 Current of H^- and D^- (crossed) beams as a function of discharge current. Figures near the curves - width of the emission slit. The emission slit length is 40 mm.

Maximum H^- emission density up to $3-4A/cm^2$ was achieved with discharge current density at cathode $50 A/cm^2$. At linear plot of dependence emission H^- current density mounts to 17% of the cathode discharge current density and energy expenditure on H^- generation was ~ 5 keV/ion. It is explained by more effective plasma utilization in SP and by geometrical focusing of negative ions to emission slit. Negative ions focusing also is confirmed by intense sputtering of anode parts located opposite to the half-cylindrical cathode surface of the groove. Sputtering trace looks like a canal of 0.8 mm width.

Under the same conditions H^- current was two times less than D^- current. Because of the larger deuterium mass the leaving times are increased both for discharge positive ions and negative ions moving from cathode to emission slit. These effects can visibly intensify the D^- destruction in plasma /2/. Also, due to lower energy of bombarding deuterium particles /4/ the reduction of secondary D^- emission coefficient may play a certain role.

The five-grooves SP with multiple-aperture extraction system was tested (Fig.1b). Quite a uniform glow discharge was achieved at all the cathodes grooves with cathode current density up to $30 A/cm^2$. With large sizes of emission slit some difficulties arise for providing necessary den-

sity of hydrogen in discharge grooves. The hydrogen density gradient along the groove resulted in non-uniform discharge and brought to visible reduction of negative ions along the emission slit.

In the described versions of SP the problem of electrodecooling is quite simply solved. To this end, the channels for cooling liquid are drilled close to working parts of the cathode, anode and extractor. Note, that SP with one groove of $\sim 3 \times 15$ mm² is effective as compact dc source of negative ions. With discharge current ~ 5 A and average power at cathode ~ 1 kW/cm² it is really to obtain dc H^- current of 0.1 A.

References:

- /1/ "Proc. Symp. on Production and Neutralization of Negative Hydrogen Ions and Beams, 1977", BNL, 50 727, N.Y.
- /2/ Yu.I.Belchenko, G.I.Dimov, V.G.Dudnikov, in /1/, p.79.
- /3/ K.Prelec, in /1/, p.111.
- /4/ P.J.Schneider, K.H.Berkner, W.G.Graham et al., in /1/, p.63.