



HAL
open science

FERMI SURFACE TOPOLOGY BY THE TWO DIMENSIONAL ANGULAR CORRELATION OF ANNIHILATION RADIATION: COPPER, A TEST CASE

A.A. Manuel, S. Samoilov, Ø. Fischer, M. Peter, A. Jeavons

► **To cite this version:**

A.A. Manuel, S. Samoilov, Ø. Fischer, M. Peter, A. Jeavons. FERMISURFACE TOPOLOGY BY THE TWO DIMENSIONAL ANGULAR CORRELATION OF ANNIHILATION RADIATION: COPPER, A TEST CASE. *Journal de Physique Colloques*, 1978, 39 (C6), pp.C6-1084-C6-1085. 10.1051/jphyscol:19786480 . jpa-00217962

HAL Id: jpa-00217962

<https://hal.science/jpa-00217962>

Submitted on 4 Feb 2008

HAL is a multi-disciplinary open access archive for the deposit and dissemination of scientific research documents, whether they are published or not. The documents may come from teaching and research institutions in France or abroad, or from public or private research centers.

L'archive ouverte pluridisciplinaire **HAL**, est destinée au dépôt et à la diffusion de documents scientifiques de niveau recherche, publiés ou non, émanant des établissements d'enseignement et de recherche français ou étrangers, des laboratoires publics ou privés.

FERMI SURFACE TOPOLOGY BY THE TWO DIMENSIONAL ANGULAR CORRELATION
OF ANNIHILATION RADIATION : COPPER, A TEST CASE

A.A. Manuel, S.Samoilov, Ø. Fischer, M. Peter and A.P. Jeavons⁺

Département de Physique de la Matière Condensée, Université de Genève,
32, Bd d'Yvoy-1211 Genève 4, Suisse

⁺ C E R N, DD-Division, 1211 Genève 23, Suisse

Résumé.- La surface de Fermi du cuivre, qui est bien connue, est utilisée pour examiner les performances d'un système de détection bi-dimensionnel de corrélations angulaires de la radiation d'annihilation du positron. Les structures attendues apparaissent dans nos résultats qui soulignent l'intérêt de cette technique pour l'étude des propriétés électroniques des métaux et de leurs alliages.

Abstract.- The well known Fermi surface of copper is used to test a newly conceived two dimensional angular correlation of positron annihilation radiation apparatus. The results reveal the expected structure and outline the potential interest of this technique to study the electronic properties of metals and alloys.

The positron annihilation technique is commonly used to study Fermi Surface(FS) topologies in metals and alloys/1/. In the last few years the tendency is to build machines with a two dimensional resolution/2/. We wish to present results for copper single crystals in different crystalline orientations obtained with a newly conceived two dimensional angular correlation detection system.

The novelty in our set-up is the position detection of the 511 keV γ annihilation radiation by means of wire chambers mounted with high density converters/3/. Two components (p_x, p_y) of the momentum distribution of the annihilated pair are determined via the two angles ($\theta_x = p_x/mc$; $\theta_y = p_y/mc$) with a resolution of 0.65 mrad \times 0.55 mrad. Thus the measured coincidence rate is :

$$N(p_x, p_y) \div \int \rho(\vec{p}) dp_z$$

The experimental set-up is described in /4/ and in the references quoted therein. When a coincidence is detected the position of the incident γ -ray in each detector is determined and the relative angular coordinates θ_x and θ_y of the annihilation are computed and used to build a two dimensional histogram of the angular annihilation rate. This histogram is corrected from the variation of the angular efficiency due to the finite size of the detectors.

Copper is an appropriate metallic system for a test measurement. It has two advantages : its FS has been extensively studied ; the necks in the $[111]$ directions provide a good tool for testing the results. Figure 1 shows the experimental angular correlation distribution when the crystalline

axes $[111]$ and $[1\bar{1}0]$ are along θ_x and θ_y respectively.

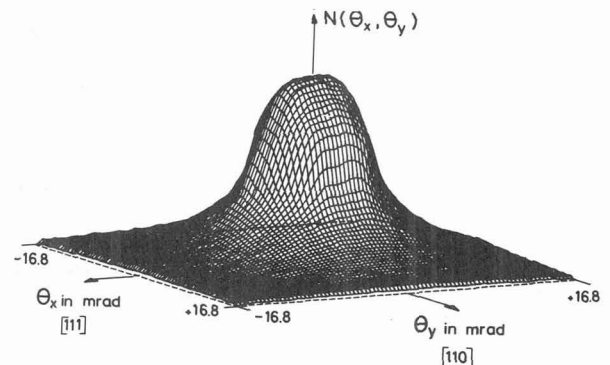

Fig. 1 : Two dimensional angular correlation of annihilation radiation in Copper single crystal oriented as shown in the figure.

Figure 2 shows the theoretical expectation on the basis of the dHVA measurements done by Halse/5/, convoluted with our experimental resolution and superimposed on a broad Gaussian distribution representing the annihilations with core electrons. This theoretical approach neglects the following contributions : high momentum components ; various many body effects ; thermal momentum, effective mass and wavefunction of the positron. Nevertheless a comparison between figure 1 and figure 2 shows that the FS topology is well reproduced in our mea-

surements.

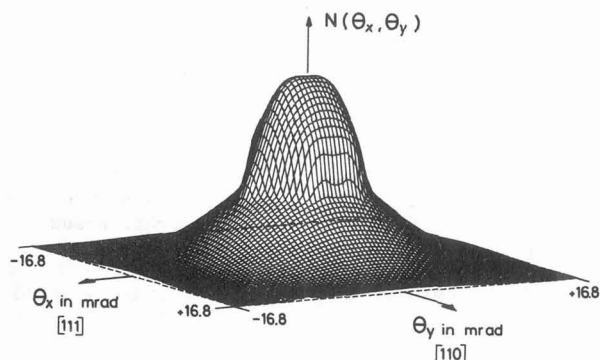

Fig. 2 : Theoretical expectation on the basis of dHvA measurements.

Figure 3 shows iso-density contour lines of this experimental result.

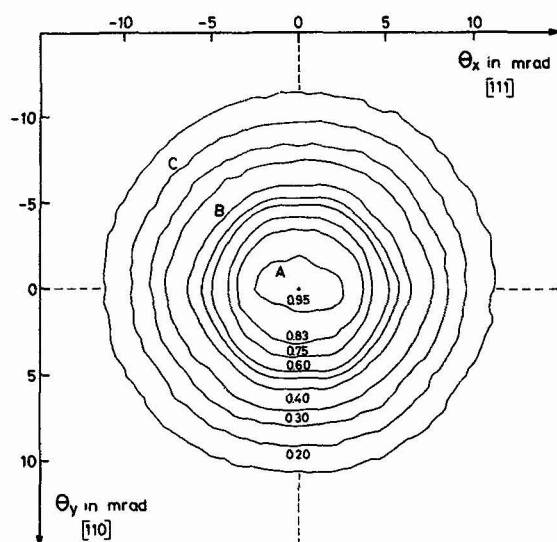

Fig. 3 : Iso-density contour lines for copper in the same configuration as figure 1.

The eight necks appear clearly : near $|\theta| = 0$ two necks give rise to the elliptical contour line (A) ; for $4 \text{ mrad} \leq |\theta| \leq 5.5 \text{ mrad}$ the six remaining necks give rise to this "6 fold symmetry" exhibited by contour line (B) ; finally at even larger angles the main contribution comes from annihilations with core electrons resulting in the quite circular contour line (C).

A second measurement was performed with the

$[11\bar{1}]$ direction pointing along the p_z axis. Figure 4 shows the experimental results.

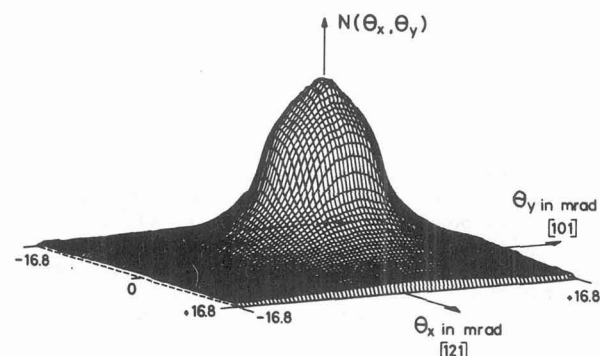

Fig. 4 : Two dimensional angular correlation of annihilation radiation in a copper single crystal oriented as shown in the figure.

The two necks present in this direction increase the annihilation rate near $|\theta| = 0$ and give rise to the bump clearly exhibited in figure 4.

References

- /1/ Berko, S. and Mader, J., Appl. Phys. 5 (1975) 287 ; West, R.N., Adv. in Phys. 22 (1973) 263
- /2/ Berko, S., Haghgooie, M. and Mader, J., Phys. Lett. 65A (1977) 355
- /3/ Jeavons, A.P., Townsend, D.W., Ford, N.L., Kull, K., Manuel, A.A., Fischer, Ø. and Peter, M., to be published in IEEE Trans. Nucl. Sc.
- /4/ Manuel, A.A., Fischer, Ø., Peter, M. and Jeavons, A.P., presented at the Wire Chamber Conference Vienna, February 1978, proceeding to be published in Nuclear Instrument and Method
- /5/ Halse, M.R., Phil. Trans. Roy. Soc. A265 (1969) 507