



HAL
open science

**III. EXPÉRIENCES PASSÉES ET FUTURES / III.
PAST AND FUTURE
EXPERIMENTSPREPARATION FOR STORAGE
RING EXPERIMENTS AT DESY**

P. Waloschek

► **To cite this version:**

P. Waloschek. III. EXPÉRIENCES PASSÉES ET FUTURES / III. PAST AND FUTURE EXPERIMENTSPREPARATION FOR STORAGE RING EXPERIMENTS AT DESY. Journal de Physique Colloques, 1974, 35 (C2), pp.C2-35-C2-44. 10.1051/jphyscol:1974206 . jpa-00215516

HAL Id: jpa-00215516

<https://hal.science/jpa-00215516v1>

Submitted on 4 Feb 2008

HAL is a multi-disciplinary open access archive for the deposit and dissemination of scientific research documents, whether they are published or not. The documents may come from teaching and research institutions in France or abroad, or from public or private research centers.

L'archive ouverte pluridisciplinaire **HAL**, est destinée au dépôt et à la diffusion de documents scientifiques de niveau recherche, publiés ou non, émanant des établissements d'enseignement et de recherche français ou étrangers, des laboratoires publics ou privés.

PREPARATION FOR STORAGE RING EXPERIMENTS AT DESY

P. WALOSCHEK,

DESY, Hamburg, Germany

Résumé. — Nous analysons brièvement la situation présente en ce qui concerne la construction du double anneau de stockage DORIS ; nous donnons également quelques informations sur deux dispositifs expérimentaux qui sont en préparation pour 1974. L'utilisation et les limitations d'un système de « tagging » sont également discutées.

Abstract. — The present state of the construction of the double storage ring DORIS is briefly reviewed, including some data from two experimental devices which are being prepared for 1974. The use and limitation of a tagging system installed along the SR-beams is discussed.

1. **Introduction.** — The present is a condensed review of the experimental facilities which should be available during 1974 for storage ring experiments at DESY. In particular, the problems involved in the detection of photon-photon interactions are described in connection with a tagging-windows system installed at the storage ring.

2. **The double storage ring (DORIS).** — We shall first recapitulate briefly the most relevant characteristics of the double storage ring (DORIS) and give an idea about its present state. Figure 1 shows a simple diagram of the beam systems, including the linac and

particles change over from the upper to the lower ring in one intersection point and vice versa in the other.

The crossing angle of the two beams is normally 12 mrad and can be reduced to 6 mrad if this may be found convenient. The beams are « focalized » on the intersection point (low beta sections) and have a divergence which is of several mrad in the horizontal plane and about 1 mrad in the vertical plane. Up to 480 bunches can be stored. The time between two bunch crossings is 2 ns. The interaction region is only a few tenths of a mm wide (radially), even smaller in height and one or two cm long.

Some improvement was obtained in the last year studying the optical parameters of the machine. A new distribution of sextupoles provides a better compensation of the chromaticity. Earlier difficulties with the accuracy of the bending magnets were removed so that now the energy should be easily varied between

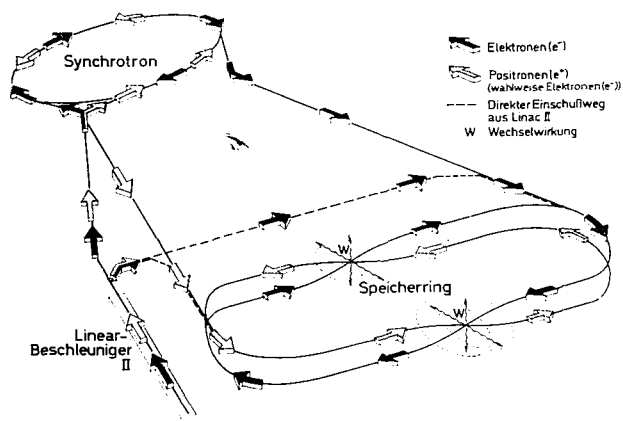

FIG. 1. — Beam transport system between DESY, DORIS and Linac.

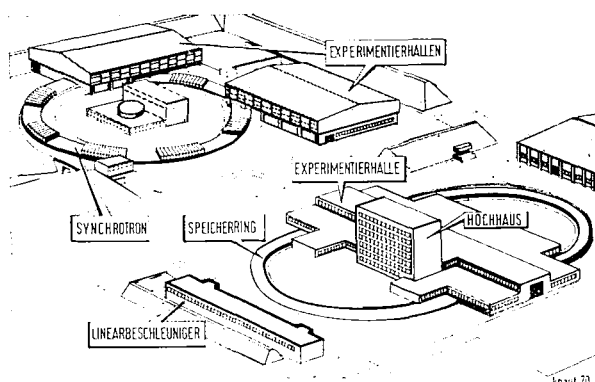

FIG. 2. — Artist view of Synchrotron, DORIS and Linac (1970).

the synchrotron as injectors. There are two superposed oval storage rings which cross at two points ; the

about 0.5 up to 3.5 GeV per beam. The maximum design luminosity is still obtained at about 2 GeV and can arrive to several times $10^{32}/s.cm^2$. At lower energies the machine should be filled with the maximum number of bunches (480), while at higher energies filling with less bunches (down to one every 8) provides the best design luminosity.

Both rings can store either electrons or positrons by inverting the magnetic field (the sense of rotation must

be kept the same due to synchrotron radiation and high-frequency problems). Therefore the machine is ready to operate for electron-positron or electron-electron collisions. The change-over takes a few days. The luminosity may be smaller by a factor 5 to 10 in the electron-electron case. However, this mode is particularly interesting for the study of photon-photon collisions.

Operation with electrons in one ring and protons



FIG. 3. — Aerial view of the installation (spring 1973).



FIG. 4. — A bending-magnet installed in the DORIS-tunnel.

in the other seems quite feasible and will be prepared during the next two years. The aim is to gain experience in this new field and to test whether a luminosity near to $10^{31}/s.cm^2$ can be achieved.

Figure 2 shows an artist view of the DESY installations made 4 years ago. All buildings are finished now and figure 3 is a photograph taken a few months ago. Figure 4 shows that also the installations are being mounted according to schedule.

The assembly of the storage ring should be completed at the end of 1973 and the first injection tests may take place early in 1974. Four of the six high-frequency transmitters will be available at that time. Once the full HF power is delivered it will be sufficient for running the storage rings up to 4 GeV. Additional power supplies for the magnets have been ordered ;

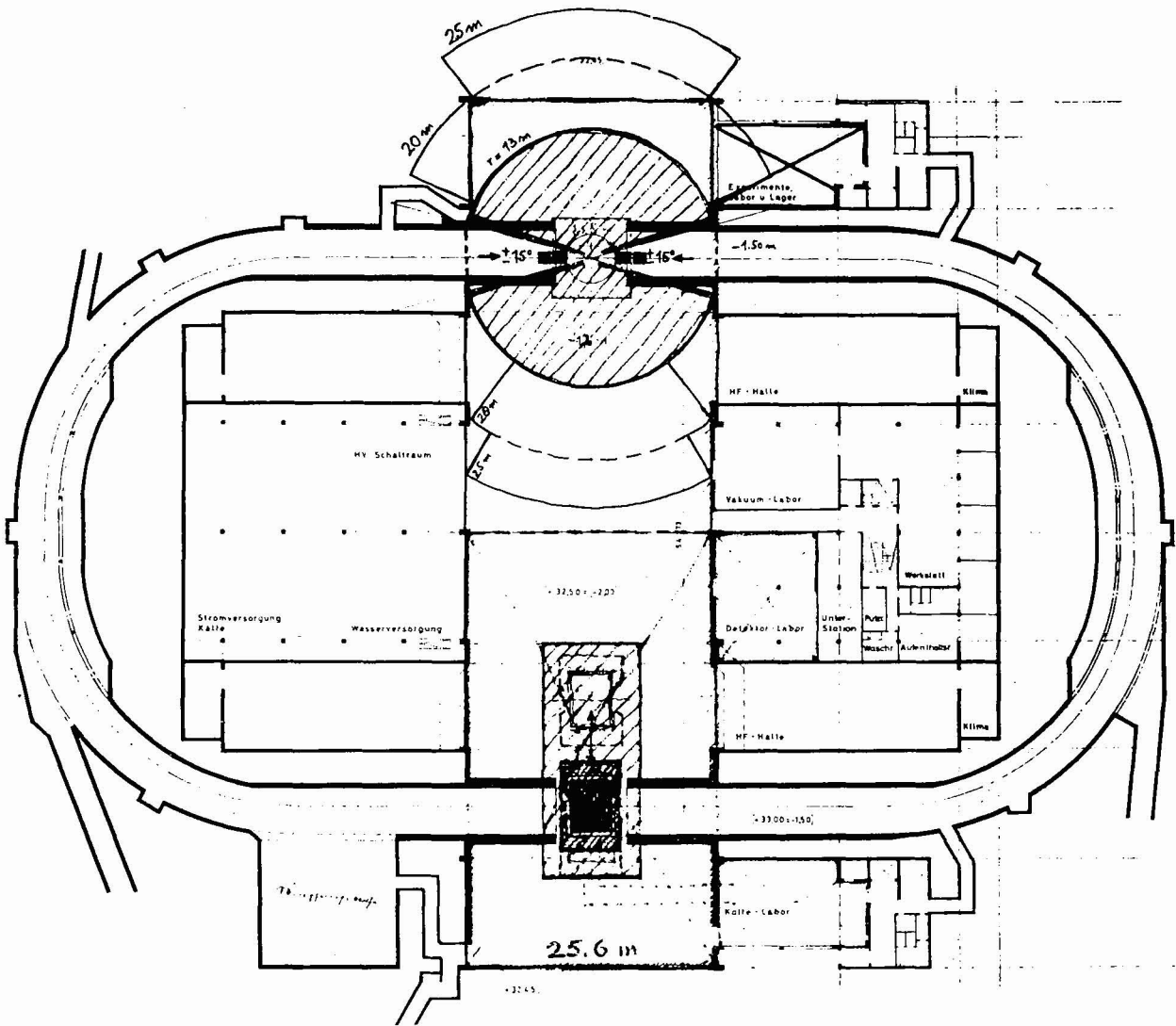

FIG. 5. — Sketch of the experimental hall and its possible use.

they would allow an operation at even higher energies (4.5 GeV). The limit for the magnets itself is near to 5.2 GeV.

Figure 5 shows the experimental hall and the possible use of the regions around the two intersection points : one is prepared for a big (4π) detector and the other one is more indicated for experiments extending in the horizontal plane. Figure 6 is a photograph of this hall in its present state. Equipment for experiments can already be installed.

Two experimental devices are being prepared at present : One is a detector with big solid angle using a solenoid type magnet (PLUTO) and the other one consists of a non-magnetic detector (also covering a big solid angle) and two lateral magnetic spectrometers of high accuracy (DASP). Both set-ups should start tests in Summer 1974.

In addition to the PLUTO and DASP detectors

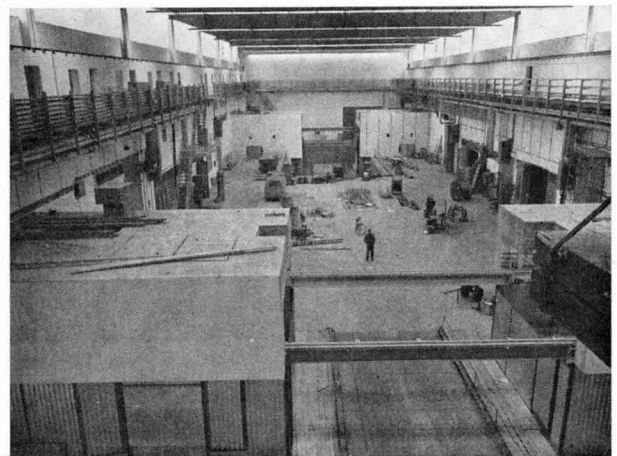

Fig. 6. — View of the experimental hall of DORIS (spring 1973).

other experiments are being studied, in particular one using NaI crystal detectors and one using neutron counters. They will not be described in this report.

3. The magnetic detector (PLUTO). — Two sections of the PLUTO-detector are shown in figures 7 and 8. The beams go along the axis of the cylinder. The space available inside the (superconducting) coils is 1.4 m in diameter and 1.15 m long. Up to 16 cylindrical Chrapak-chambers are used to trigger the system and measure the trajectories of particles. Lead cylinders of different diameter can be introduced for the conversion of γ -rays. For the identification of μ -mesons the iron-return is used. Proportional chambers are introduced for this in the gaps of the yoke. The magnetic field in the inner space is 20 kG and quite homogeneous. Two additional coils placed on each side

(along the beam) compensate the effect of the magnetic field on the stored beams. Figure 9 shows these coils as well as a second solution, the « shielding-coil », which leaves a region with no field on the SR beams. The latter has been built for the eventuality that the « compensation-coils » disturb the SR.

The PLUTO-detector covers a solid angle of 94 % of 4π (20° to the beam) and measures momenta with $\sim 5\%$ accuracy (at 1 GeV) over about 65 % of 4π .

The problem of triggering the PLUTO-detector and reducing the number of events to be recorded (PDP-11/45 connected to the DESY-IBM system) has been particularly investigated. A hardware system which selects events (within $30\ \mu\text{s}$) in a way similar to a « filter »-programme, has been developed and is being tested at the ADONE-Storage Ring with a small non-magnetic detector covering 92 % of 4π .

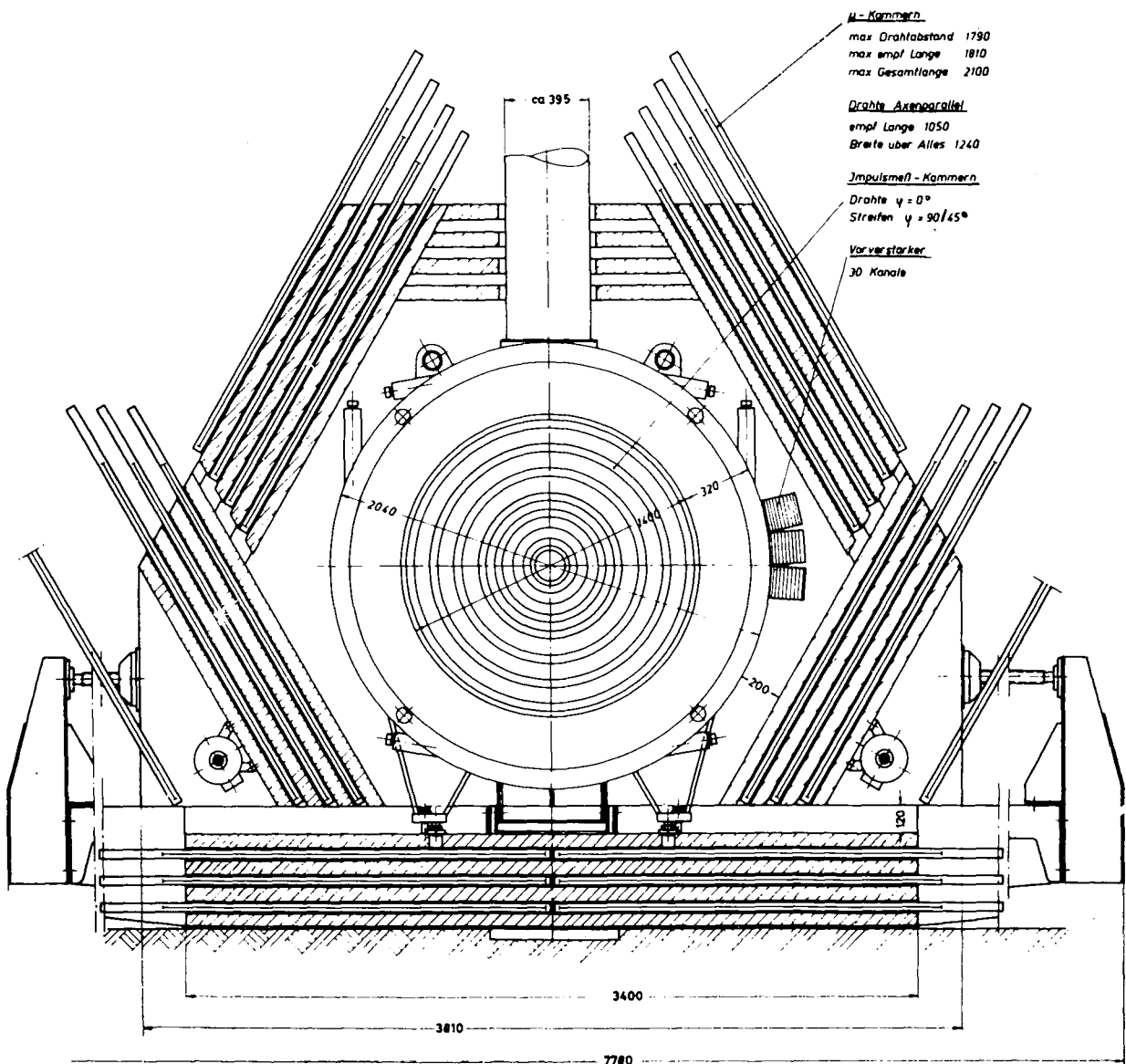

FIG. 7. — Section of the PLUTO magnetic-detector (normal to the beam).

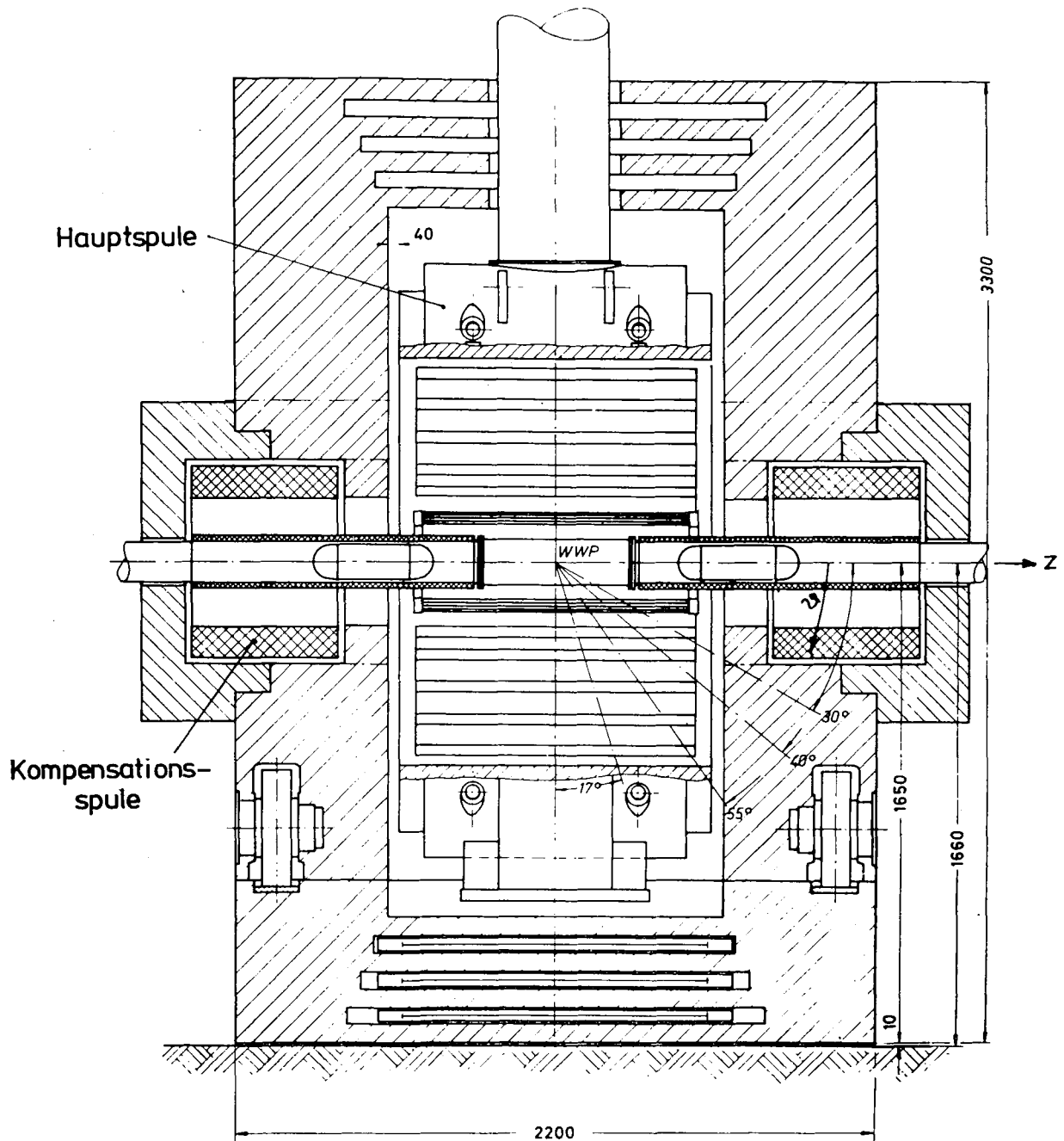
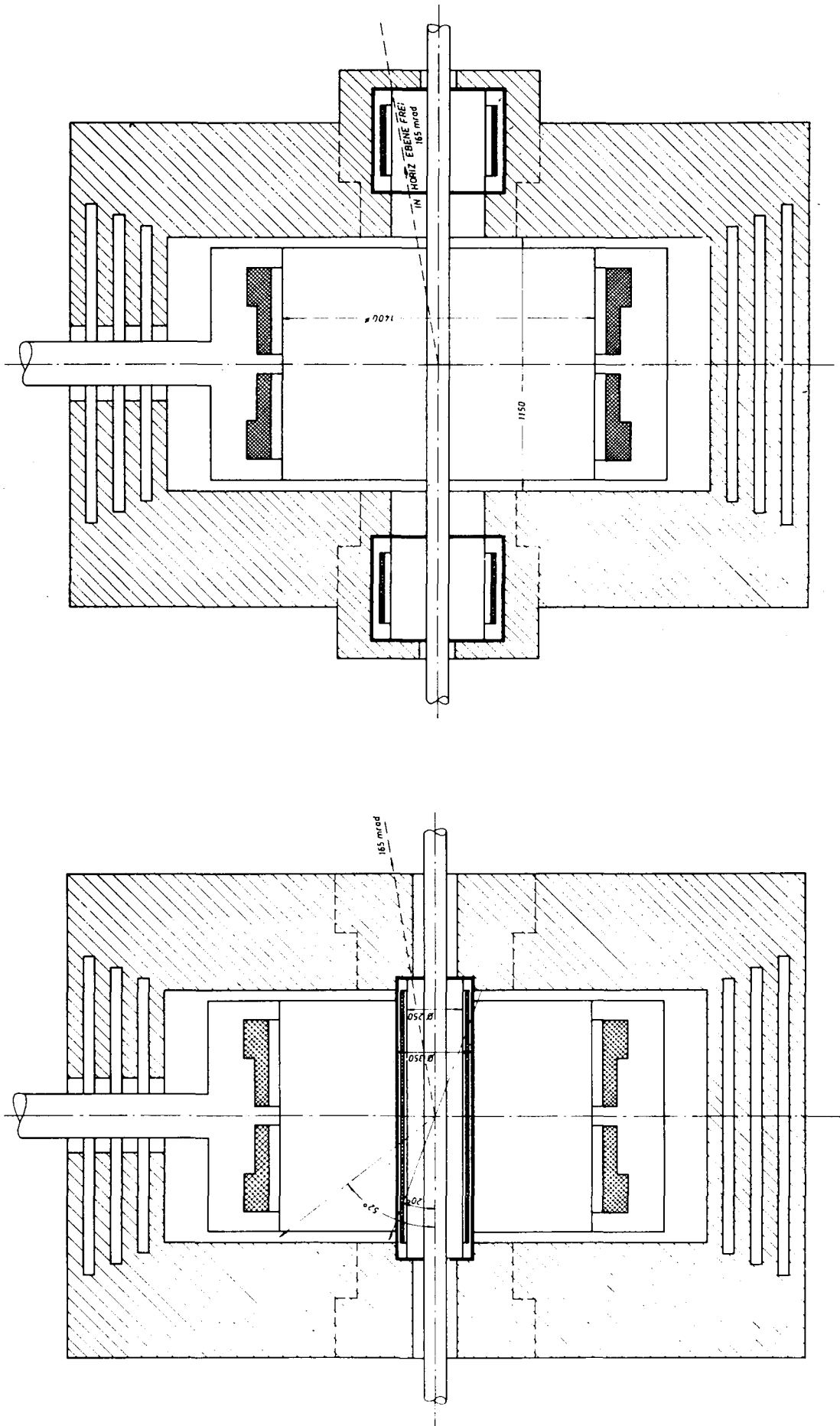

FIG. 8. — Section of PLUTO containing the beam.

The luminosity will be monitored by counter telescopes outside the PLUTO-magnet. In addition to the usual scintillators and shower counters a system of proportional chambers will be used to check the obtained data.

4. **The double-arm spectrometer (DASP).** — Figures 10 and 11 show two sections of the DASP-detector. The inner part, in one of its possible configurations ($3 \times 3 \times 1.5 \text{ m}^3$) is shown in figures 12 and 13. A solid angle of 87 % of 4π is covered with plastic scintillators and proportional chambers to determine the directions of charged particles. Part of the chambers

are separated by lead plates for the localization of converted photons. Shower-counters (lead-sandwich type) surround most of this inner part. In two lateral windows (~ 0.45 sterad each) the amount of material is minimized. Particles emerging through these windows reach the external part of the detector after passing about 18 kGm of magnetic field. Spark chambers (magnetostriction type $5.6 \times 1.8 \text{ m}^2$) are used to determine the trajectories; plastic scintillators for time of flight, shower counters and two 90 cm iron absorber complete the set-up. The momentum resolution at 2 GeV/e will be better than 0.5 %. In the configuration shown the angle to the beam covered



Prinzipskizze der Abschirmspule (I)

(a)

Prinzipskizze der Kompensationsspulen (II)

(b)

Fig. 9. — The shielding coil (left) and the compensation coils (right) of the PLUTO magnet.

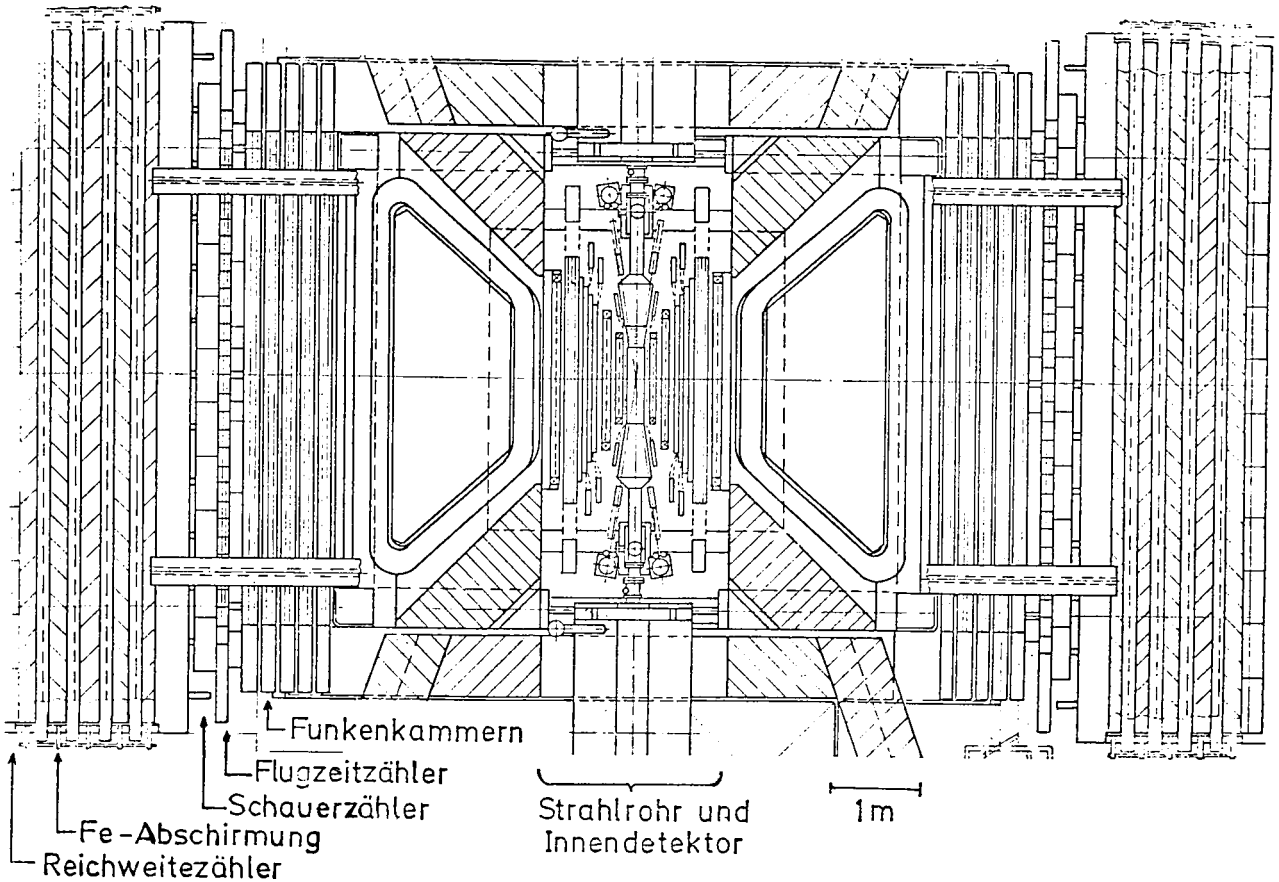

FIG. 10. — Horizontal section of the DASP-detector system.

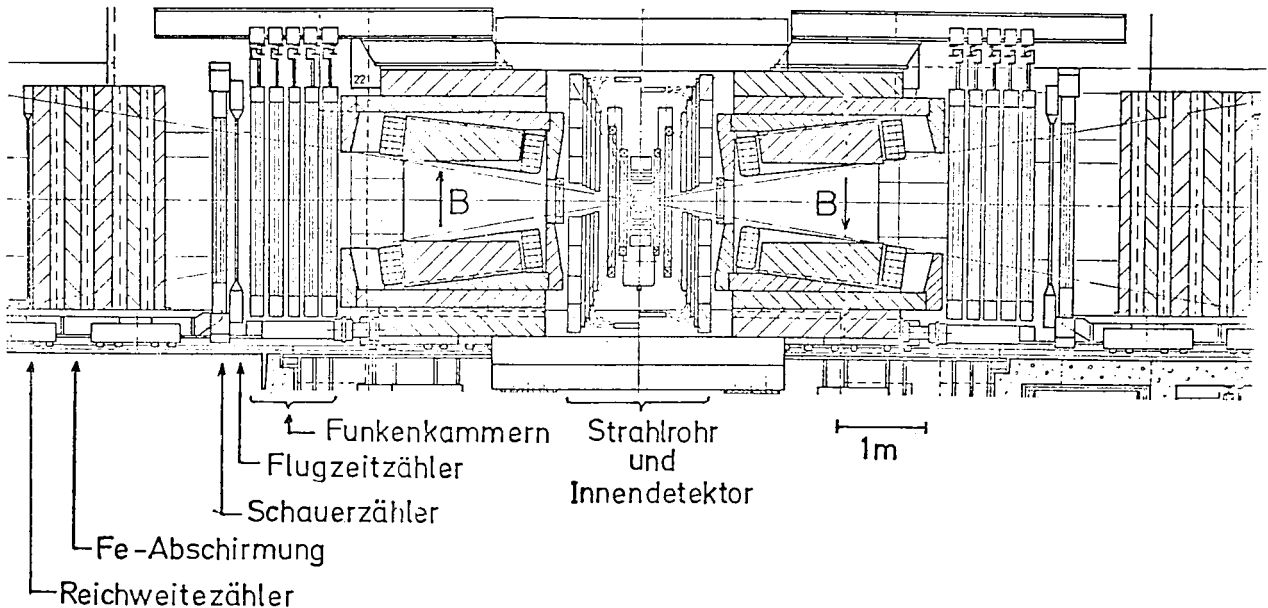

FIG. 11. — Vertical section of the DASP-detector.

by the spectrometers is 48° to 132° and the azimuth $\pm 10^\circ$.

The information obtained for each event : amplitudes, time of flight, coordinates, etc., is recorded in a PDP-11/45 connected to the central IBM system. Out

of the high accuracy in the momentum-measurement, emphasis is placed on particle-identification.

The small-angle-ee luminosity-monitor used is also shown in figures 12 and 13 in the inner part of the DASP-detector. It consists of plastic scintillators and

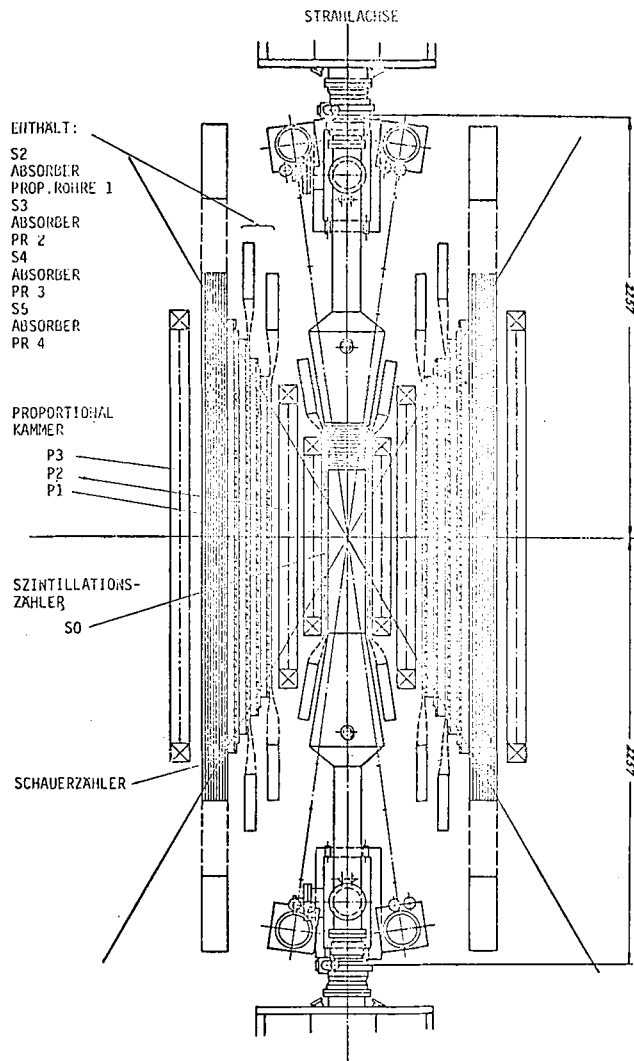

FIG. 12. — Inner part of the DASP-detector (section containing the beam).

shower counters. The particular shape of the vacuum-tube in this region makes it possible to install additional detectors for particles emerging at angles between 6° and 10° to the beam. These may be useful for the identification of photon-photon interactions.

5. The tagging system. — The possibilities of using electron-electron collisions for the study of photon-photon interactions has been pointed out to us by P. Kessler during the Liverpool Conference in 1969. Since then we have tried to include in the DORIS project some adequate means for detecting secondary electrons emitted at very small angles. Some windows along the vacuum pipe had already been planned for beam and luminosity monitoring. They were improved as much as possible and their final position is shown in figure 14, together with particle trajectories in a deformed scale. The bending power of several magnets (quadrupoles included) is used to separate particles which have less momentum than the beam. Their trajectories are included in figure 14. Only at four

positions on each side of the interaction point, useful « tagging » counter systems can be mounted.

At each of the four « stations », particles are observed as coincidences between two small hodoscopes covering up to a maximum area $\Delta x \cdot \Delta y$ given in table I. The mean momentum (respect to the beam) accepted by each station is included. It was calculated for particular optic parameters of the storage ring and should not be considered as definitive. The single bremsstrahlung (SB) cross-section seen by each of the stations is shown in the last column of the table.

TABLE I

Station	Distance from IP	Area $\Delta x \cdot \Delta y$	Momentum p/p_0	SB
1	4 m	$10 \times 6 \text{ cm}^2$	$(23 \pm 4.5) \%$	3.7 mb
2	6 m	$10 \times 3 \text{ cm}^2$	$(36 \pm 1.5) \%$	0.7 mb
3	12 m	$10 \times 7 \text{ cm}^2$	$(81 \pm 5.5) \%$	26 mb
4	18 m	$10 \times 3 \text{ cm}^2$	$(92 \pm 2.7) \%$	53 mb

Due to the high background rates expected, the time information of the tagging counters can only be recorded (to $\pm 1 \text{ ns}$) when a candidate-event has been found in any detector placed around the interaction point. The signals can then be correlated to the exact bunch crossing time at which the event was generated. For a luminosity of $10^{32}/\text{cm}^2 \cdot \text{s}$ the probability of finding a SB-event within the same bunch crossing time is about 1.5 % on each side. This is a serious limitation of the system : the tagging information is useful mainly for events which by their own kinematics are already good candidates for photon-photon interactions.

If one assumes that by kinematics and timing the tagged photon-photon events are clearly identified, it still remains a complicated problem at DORIS to calculate the real efficiency (acceptance) of the system. The momentum-band accepted by each window depends on the crossing angle and divergency of the SR beams and on the optical parameters of the rings. Furthermore there is a correlation between the angle of emission (in space) and the momentum of the tagged particles. In particular, there is no isotropy in azimuth, which complicates the interpretation and comparison with theory.

During the first operational period of DORIS the tagging-windows will be equipped with counters for luminosity monitoring. It should be learned whether the background conditions allow any further work with them. The DASP and PLUTO groups will try to identify photon-photon interactions without using (at the beginning) the tagging system. A particular advantage can be obtained if an early operation with $e^- e^-$ happens to be feasible.

Acknowledgments. — I am very grateful to Drs. H. C. Dehne, K. Steffen and G. Wolf for providing me data for this report.

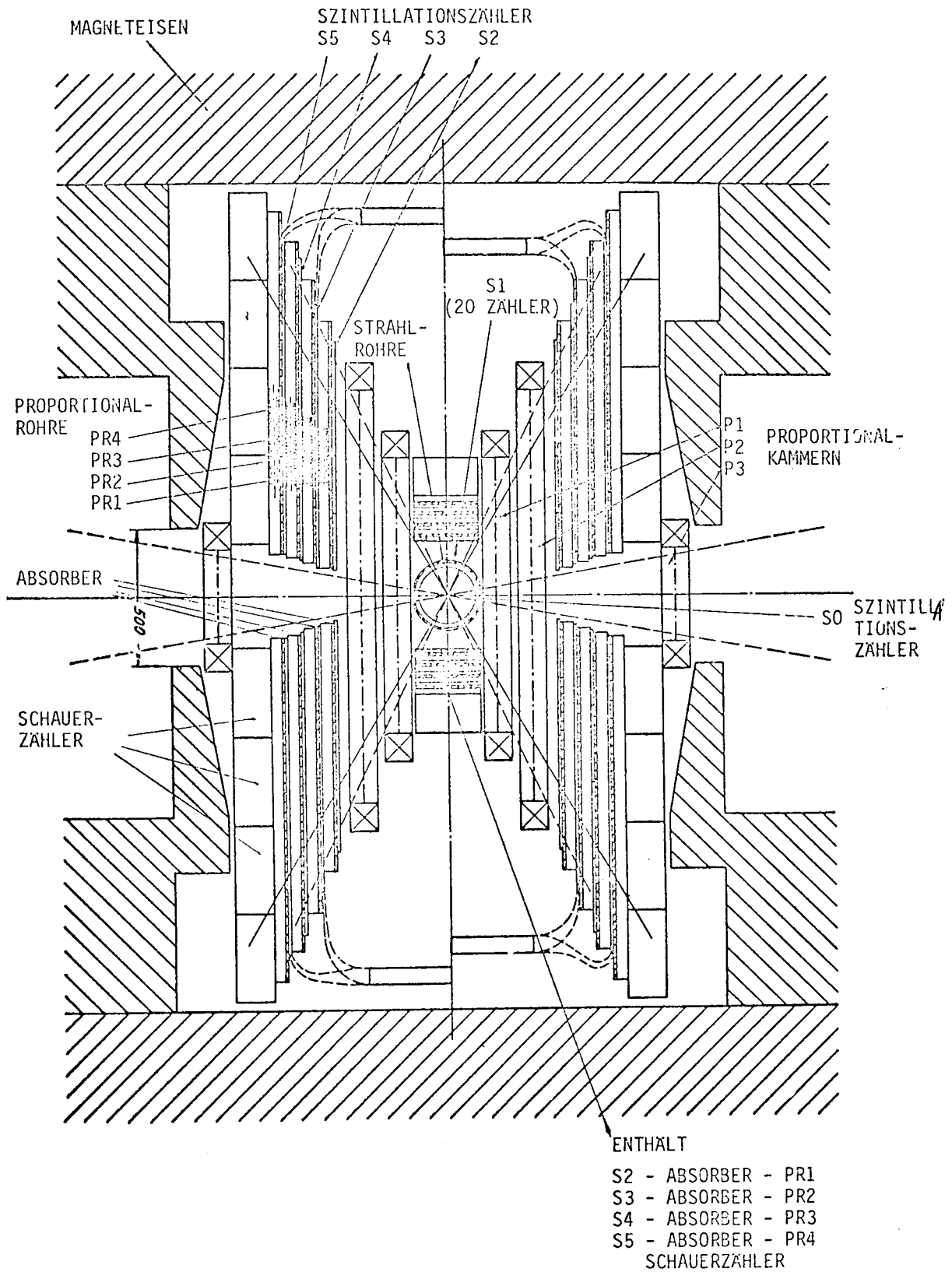

FIG. 13. — Section of the inner part of DASP (normal to the beam).

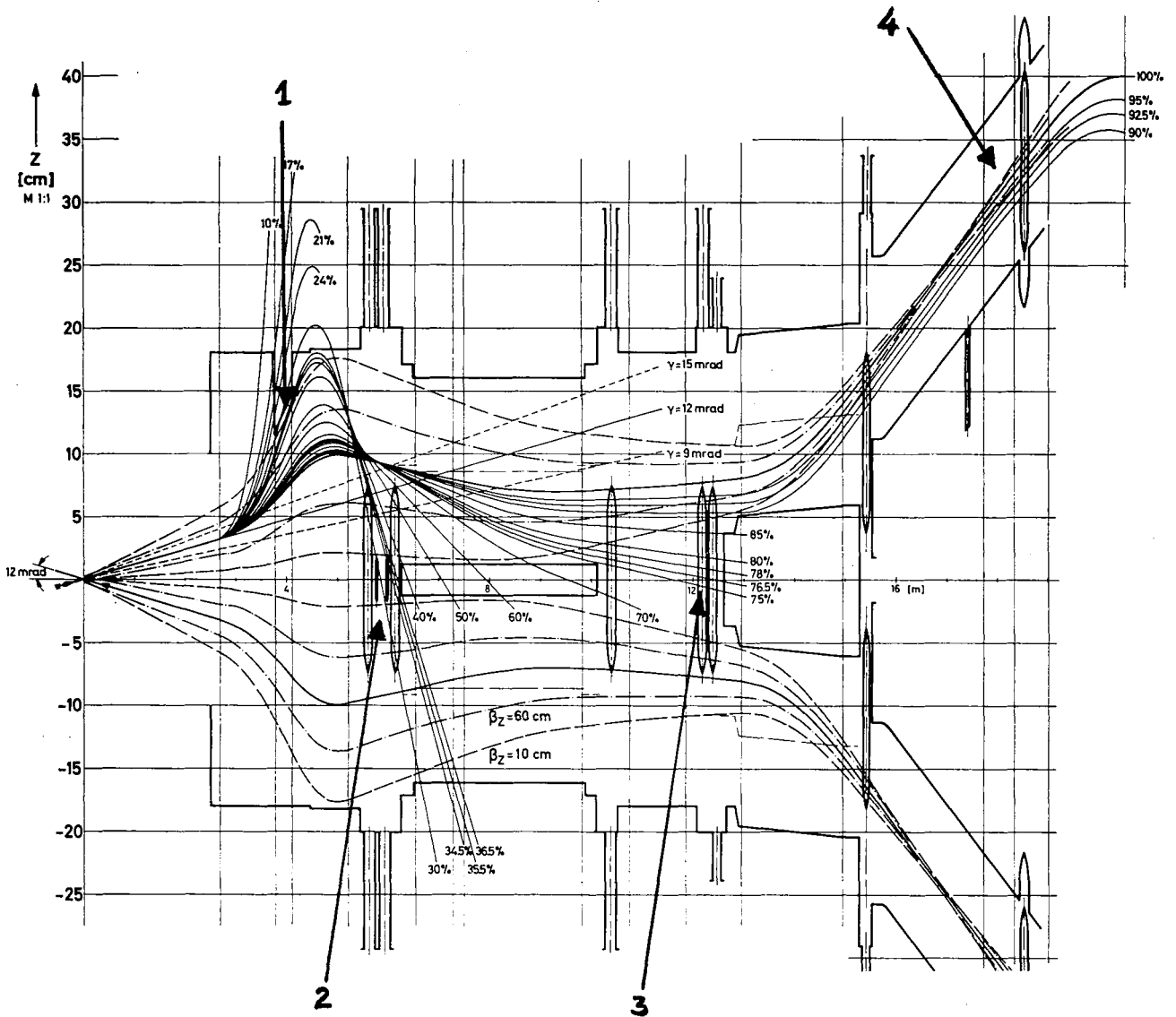

FIG. 14. — Beam orbits in DORIS (first 19 m from interaction point). The arrows show the positions of the tagging windows

DISCUSSION

H. TERAZAWA. — Is it not possible to put small tagging counters inside of the inner counters' system of the DASP, for instance ?

P. WALOSCHEK. — In principle, one can go very close to the beam (perhaps down to 20 mrad) with small counters. In practice, there are problems with the vacuum pipes, cooling for synchrotron radiation and excessive background.

G. BARBIELLINI. — May I make a comment on the background problem ? The angular distribution of the quasi-forward emitted electron in beam-beam bremsstrahlung on the one hand, and in photon-photon

collisions on the other hand, is substantially different. (Whereas $\bar{\theta} \approx m/E$ in bremsstrahlung, $\theta \approx \sqrt{m/E}$ in the two-photon process.) This fact can be used to improve the background conditions in the tagging counters.

C. BERNARDINI. — Cannot tagging be avoided in the case of electron-electron collisions ?

P. KESSLER. — I am not so sure of that, since even in electron-electron collisions you still have the « theoretical background », i. e. the contribution of the other diagrams of the same order in QED.