



HAL
open science

NONCUBIC CENTERS IN CUBIC CRYSTALS AND THEIR SPECTRA IN EXTERNAL FIELDS

A. Kaplyanskii

► **To cite this version:**

A. Kaplyanskii. NONCUBIC CENTERS IN CUBIC CRYSTALS AND THEIR SPECTRA IN EXTERNAL FIELDS. Journal de Physique Colloques, 1967, 28 (C4), pp.C4-39-C4-48. 10.1051/jphyscol:1967406 . jpa-00213293

HAL Id: jpa-00213293

<https://hal.science/jpa-00213293>

Submitted on 4 Feb 2008

HAL is a multi-disciplinary open access archive for the deposit and dissemination of scientific research documents, whether they are published or not. The documents may come from teaching and research institutions in France or abroad, or from public or private research centers.

L'archive ouverte pluridisciplinaire **HAL**, est destinée au dépôt et à la diffusion de documents scientifiques de niveau recherche, publiés ou non, émanant des établissements d'enseignement et de recherche français ou étrangers, des laboratoires publics ou privés.

NONCUBIC CENTERS IN CUBIC CRYSTALS AND THEIR SPECTRA IN EXTERNAL FIELDS

A. A. KAPLYANSKII

A. F. Ioffe Physical Technical Institute, Academy of Sciences of U. S. S. R., Leningrad K-21, U. S. S. R.

Résumé. — Après une revue sommaire des propriétés générales de centres locaux dans le réseau cubique, possédant leur propre symétrie ponctuelle, non cubique, les points suivants sont traités : 1) classification des centres non cubiques (CN) en sept catégories d'après la classe de leur symétrie et orientation dans le réseau ; 2) nombre de positions énergétiquement équivalentes de CN à orientations différentes dans le cristal (« dégénération d'orientation ») ; 3) modèles en oscillateur pour les transitions optiques aux CN et anisotropie optique « latente » des cristaux cubiques renfermant des CN. Le principe général de l'étude des CN est discuté, qui consiste à faire usage d'une action anisotrope sur le cristal, intéressant sélectivement certains groupes de centres. Les propriétés caractéristiques de la fission des raies du spectre des CN sont examinées, sous l'action sur le cristal : 1) de la déformation élastique uniaxe (« effet piézo-spectroscopique ») ; 2) du champ électrique extérieur (effet linéaire de Stark pour des centres dépourvus d'inversion) ; 3) du champ magnétique extérieur. Il est rendu compte de l'information sur les propriétés des centres et des transitions optiques, obtenue en examinant les spectres sous l'influence des effets extérieurs. Des exemples sont donnés de l'étude expérimentale de la fission associée à la déformation et de l'effet linéaire de Stark pour une série de raies sans phonon dans les spectres du fluorure de lithium coloré.

Abstract. — A short review is given of the general properties of local centers in a cubic lattice which possess an inherent noncubic point symmetry. The subjects considered are : (1) classification of noncubic centers into 7 types in accordance with the class of their symmetry and orientation in the lattice ; (2) the number of energetically-equivalent positions of noncubic centers differing in orientation in the crystal (« orientational » degeneracy) ; (3) oscillator models for optical transitions in noncubic centers and « latent » optical anisotropy of cubic crystals with noncubic centers. A general approach to the study of noncubic centers is discussed consisting in applying an anisotropic perturbation to a crystal which would act selectively on individual groups of centers. Also considered are characteristic properties of the splitting pattern of spectral lines of noncubic centers with the following perturbations applied to the crystal : (1) elastic uniaxial strain (a « piezo-spectroscopic » effect) ; (2) external electric field (a linear Stark effect for centers which do not possess inversion) ; (3) External magnetic field. Information concerning the properties of centers and of optical transitions obtained in the study of spectra under application of external perturbations is reviewed. Examples are given of an experimental investigation of the strain-induced splitting and of the linear Stark effect for a number of zero-phonon lines in the spectra of colored lithium fluoride.

1. **Introduction.** — A fairly large part of various impurity and defect centers in cubic crystals possess an inherent point symmetry corresponding to lower, namely noncubic symmetry groups [1]. In particular, most of the types of color centers are noncubic. Figure 1 shows schematically some well known noncubic centers in the lattice of alkali halide crystals :

1. M is a color center consisting of two F -centers and possessing rhombic symmetry ;
2. An association of two impurity ions (ion pairs) ;
3. An association consisting of a divalent impurity ion and a cation vacancy. Such associations of an impurity ion with another charged defect occur frequently in the case of heterovalent activation where

the defect charge produces a local compensation of the excess impurity charge ;

4. An imbedded molecule or radical which retain their characteristic features in the crystal lattice ;
5. A single impurity ion or Frenkel defect located at a point with a noncubic local symmetry of the crystal field ;
6. An impurity ion located at a point with the cubic symmetry destroyed through a displacement of surrounding atoms, for instance, as a result of the Jahn-Teller effect ;
7. A self-trapped hole (a V_k -center).

These examples which could be made more numerous illustrate the diversity in the physical nature of

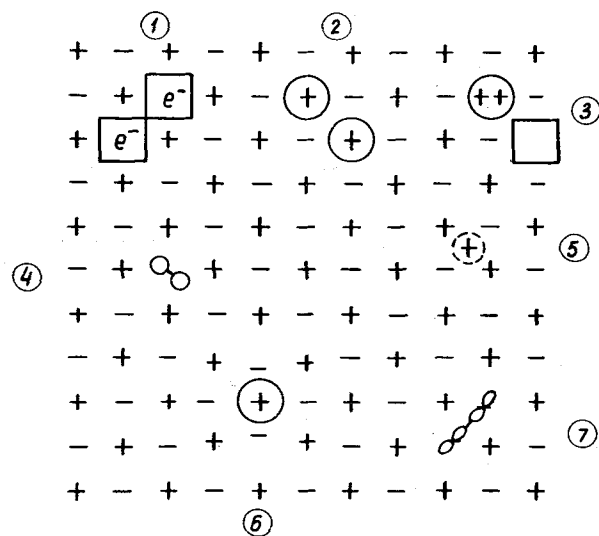

FIG. 1. — Noncubic centers in the lattice of alkali halide crystals.

«non-cubicity» and the prevalence of this type of centers.

The presence in a high symmetry cubic lattice of noncubic centers with strongly anisotropic physical properties brings about specific changes in various physical phenomena observed in crystals with such centers, as well as some completely new phenomena. The study of these phenomena yields information on the properties of noncubic centers.

Many important properties of noncubic centers and the associated phenomena are determined exclusively by the symmetry of the centers and do not

depend on their physical nature. It is these most general properties of noncubic centers determined by their symmetry which represent the subject of the present review report. In many cases these properties can be derived on the basis of simple symmetry considerations, elementary group theory methods and phenomenological perturbation theory. Thus in its major part this report will deal with noncubic centers of any physical nature.

2. General Properties of Noncubic Centers [2].

CENTER SYMMETRY. — The point symmetry group of a center belongs to crystallographic groups representing subgroups of the crystal point group. We shall consider here crystals of the class O_h which include many crystals of interest for the solid state physics, among them alkali halide crystals.

Table 1 shows O_h subgroups divided into crystallo-

TABLEAU 1

1. Tetragonal	$D_{4h}, D_4, C_{4v}, D_{2d}$ C_{4h}, C_4, S_4
2. Trigonal	D_{3d}, D_3, C_{3v} C_{3i}, C_3
3. Rhombic	D_{2h}, D_2, C_{2v}
4. Monoclinic	C_{2h}, C_2, C_s
5. Triclinic	C_i, C_1

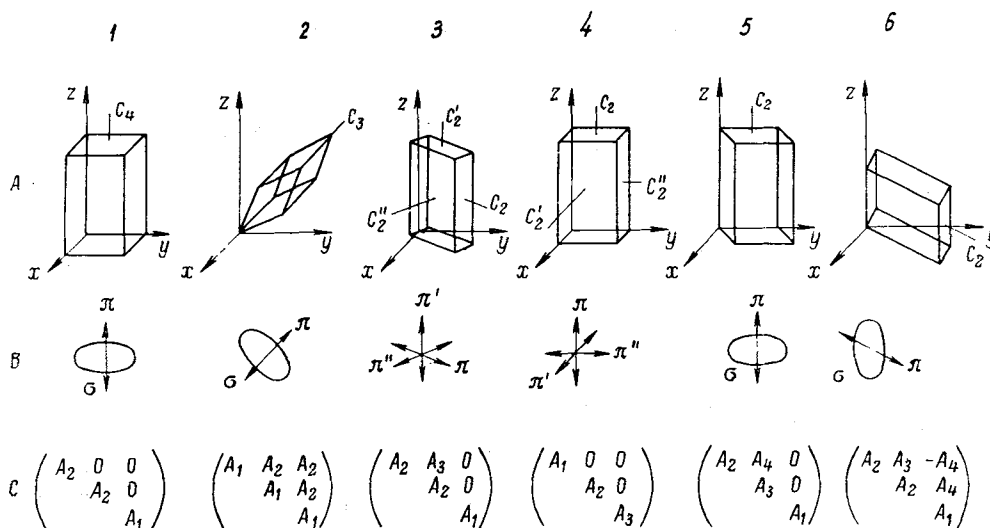

FIG. 2. — Noncubic centers in a cubic lattice.

A : polyhedra characterizing the symmetry of centers ; B : dipole oscillators of centers ; C : piezospectroscopic tensor for centers.

graphic classes. It can be seen that there can exist in a O_h -crystal centers belonging to the tetragonal, trigonal, monoclinic and triclinic symmetry classes. It should be noted that the above symmetry groups are realizable in principle, however in practice some of them are apparently not realized in crystals. Hexagonal centers cannot exist in cubic crystals.

The axes and planes of symmetry of the centers are oriented in the lattice in accordance with definite crystallographic directions. Figure 2A shows a possible arrangement in the cubic lattice of centers of the five abovementioned symmetry classes. The centers are conventionally denoted by polyhedra corresponding to the highest symmetry of a given class. Rectangular coordinates x, y, z are directed along the three cube axes. It turns out that only seven types of noncubic centers can exist in a cubic crystal, which will differ in the symmetry class and orientation in the lattice, namely :

1. Tetragonal centers with a fourfold axis directed along the $\langle 100 \rangle$ axis of the crystallographic cube.
2. Trigonal centers with a threefold axis oriented along the $\langle 111 \rangle$ spatial diagonal of the cube.
3. Rhombic centers I with orthogonal twofold axes (or normals to the symmetry planes) oriented along the $\langle 110 \rangle, \langle \bar{1}\bar{1}0 \rangle, \langle 001 \rangle$ directions.
4. Rhombic centers II with three orthogonal twofold axes oriented along the three cubic axes.
5. Monoclinic centers II with a twofold axis (or a normal to the symmetry plane) coinciding with the $\langle 100 \rangle$ direction.
6. Monoclinic centers I with a twofold axis (or a normal to the symmetry plane) coinciding with the $\langle 110 \rangle$ direction.
7. Triclinic centers whose orientation in the lattice is not restricted by any conditions.

ORIENTATIONAL DEGENERACY OF CENTERS. — The most important feature of noncubic centers consists in that the centers occupy in the cubic lattice several energetically equivalent positions with different orientation. This is illustrated by figure 3 showing several positions of a particular type of centers which, as is seen, are oriented along several $\langle 110 \rangle$ directions. The number of such orientations or, in other words, the multiplicity of the orientational degeneracy of centers R is equal to the ratio of the orders of the crystal symmetry groups G and of the center

$$g (R = G/g).$$

TABLE 2

D_{4h}	3
D_{3d}	4
$C_{4v}, D_{2d}, D_4, C_{4h}, D_{2h}$	6
S_6, C_{3v}, D_3	8
$C_4, S_4, C_{2v}, D_2, C_{2h}$	12
C_3	16
C_2, C_s, C_i	24
C_1	48

Table 2 shows the multiplicity of orientational degeneracy for centers of different symmetry in O_h crystals for which $G = 48$. It is seen that the less symmetrical the centers are, the larger is the number of ways in which they can arrange in the lattice.

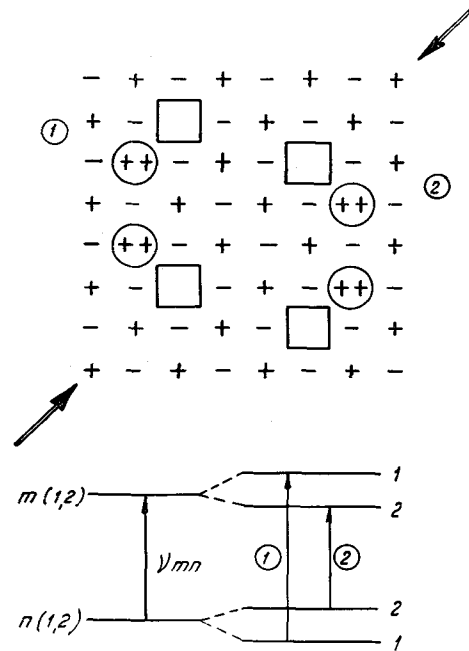

FIG. 3. — Diagram of orientational degeneracy of centers and of its lifting as a result of uniaxial compression.

Under ordinary conditions all possible positions are populated with equal probability. The centers form in a crystal R differently oriented groups with statistically the same number of centers in each group. The existence of several groups of noncubic centers in a crystal together with the anisotropy of physical properties of individual centers determine the specific properties of cubic crystals with noncubic centers.

OPTICAL PROPERTIES OF CENTERS. — The properties of optical transitions between electron levels of a center are determined by matrix elements of the electric

or magnetic dipole moment for the electric and magnetic transitions, respectively. Nonzero elements for transitions between different levels are given by group-theoretical selection rules.

The optical properties of centers can be conveniently described using the analogy between the probability of a quantum mechanical transition and the emission of a classical dipole oscillator. A transition with one nonzero component of the electric dipole moment can be considered as the case of a linear Hertz oscillator. As is well known, the spatial distribution of emission of such a dipole is strongly anisotropic in character. There is no completely polarized emission in the direction of dipole vibration, and it is maximal in the equatorial plane. Following this analogy, one can consider each transition in the center as due to an oscillator with a definite shape and orientation in the center.

Figure 2B shows elementary oscillators describing transitions in centers of different symmetry which were obtained by means of the group — theoretical analysis. In tetragonal and trigonal centers are possible linear π -oscillators along the center axis and plane circular σ -oscillators normal to it. In rhombic centers we can have π -oscillators oriented along the three center axes. In monoclinic centers there are possible linear π -oscillators oriented along the axis, or plane elliptical oscillators at right angles to it. For each center combinations of these oscillators are also possible. Therefore absorption or emission of light by individual centers is characterized, as a rule, by a strong anisotropy in spatial distribution.

The oscillator orientations are rigidly fixed with respect to the crystallographic axes in accordance with the actual center positions shown in figure 2. It is essential that the orientation of the dipole oscillators in the lattice is in some cases not uniquely connected with the center symmetry. Indeed, $\langle 100 \rangle$ linear oscillators can exist with four types of centers — tetragonal, rhombic I, rhombic II and monoclinic II. This should be taken into consideration in the determination of the geometrical center symmetry from the properties of dipole transitions in the centers.

The anisotropy of optical properties of individual noncubic centers results in an anisotropic absorption and emission of light by each group of « parallel » centers of a definite orientation in a crystal. However the optical anisotropy of centers becomes completely averaged out owing to the existence in a lattice of several possible orientations for noncubic centers and to a statistically uniform distribution of centers with respect to these orientations. As a result, a cubic

crystal with noncubic centers is optically isotropic throughout the spectral region. Feofilov has termed this effect a « latent » optical anisotropy of noncubic centers [3].

3. Spectra of Noncubic Centers in External Fields. — To reveal and to study the latent anisotropy of noncubic centers in cubic crystals, one should subject the crystal of interest to some anisotropic external action which would selectively affect individual groups of centers [1]. Since the physical properties of centers are strongly anisotropic, the effect of a directional perturbation, and hence the response of centers to this perturbation will be different for centers of different orientation with respect to the direction of outer action. Studying the response of centers to a differently oriented perturbation, which may reveal itself in various physical phenomena, one can gain information on noncubic centers in the lattice.

To exert directional action, one can use :

1. Polarized (or nonpolarized) light beams ;
2. Uniaxial elastic compression (or tension) ;
3. External electric field ϵ ;
4. External magnetic field H .

All the existing methods of study of the noncubic centers in cubic crystals are based on the use of the above actions or their combinations.

Indeed, polarized light as a means of selective excitation of individual center groups is employed in two well known techniques which have found wide use in the study of color centers in crystals : *a*) anisotropic bleaching of crystals with centers (Nikitine [4], Ueta [5], Feofilov [6]) ; *b*) polarized luminescence (Feofilov [7]). The study of these phenomena yields the « optical structure » of the centers, i. e. the orientation in the lattice of oscillators describing the corresponding transitions, which permits to infer data on the geometric symmetry of the centers. It would be of interest to extend the available calculations of bleaching and polarized luminescence to all abovementioned oscillator combinations which can exist in noncubic centers of different symmetry.

The effect of the other three actions — strain, electric and magnetic fields — on noncubic centers can be studied in a number of physical phenomena. We shall dwell here on the corresponding effects in optical spectra of crystals. The role of these spectroscopic methods in the investigation of color centers has considerably increased due to the discovery in the spectra of many color centers of a discrete vibronic structure

including sharp zero-phonon lines of purely electronic transitions (see, for example, [8-11]).

EFFECT OF ELASTIC STRAIN ON THE SPECTRA OF NONCUBIC CENTERS. — A « piezospectroscopic » method has been proposed and used in 1959 [12] in the study of noncubic centers in cubic crystals. It is based on the investigation of the splitting of spectral lines of centers in uniaxially stressed crystals. Consider a crystal with noncubic centers occupying several energetically equivalent positions 1, 2, ... (Fig. 3). Assume transitions between any two nondegenerate levels of the centers *m, n* to give in the spectrum a line of frequency ν_{mn} which in a free crystal is the same for all centers 1, 2, ... Now subject the crystal to uniaxial compression along the P-axis. The strain will obviously act differently on centers 1, 2, ... which have different orientations with respect to the compression axis. These centers become now energetically nonequivalent (the lifting of orientational degeneracy), and the optical transition frequencies ν_{mn} in the centers become different because of a different shift of the corresponding levels. Thus strain should result in a splitting of a single spectral line into several components, each of them associated with transitions in the groups of centers with a definite orientation relative to the axis of compression.

As is seen, this splitting is not connected with any real energy level splitting of individual centers but is due only to a different shift of levels in the centers oriented differently with respect to the compression axis. It should be noted that this splitting should in principle occur always, with any transitions in any centers of noncubic symmetry.

The three principal characteristics of splitting observed experimentally — the number, the shifts, the intensity and polarization of the strain splitting components — are closely connected with the most important microcharacteristics of noncubic centers.

Table 3 shows the number of splitting components

TABLEAU 3

Centres \ Stress	< 100 >	< 111 >	< 110 >
Tetragonal	2	1	2
Trigonal	1	2	2
Rhombic I	2	2	3
Rhombic II	3	1	3
Monoclinic I	2	3	4
Monoclinic II	3	2	4
Triclinic	3	4	6

in a crystal compressed along the < 100 >, < 111 > and < 110 > directions for centers of the above seven possible types of noncubic centers. It is seen that the number of components depends uniquely on the actual type of center.

The transition frequency shift for a center can be written in the following form

$$\Delta\nu = \sum_{i,k=x,y,z} A_{ik} \sigma_{ik}$$

where σ_{ik} are stresses in the lattice, and A_{ik} some coefficients which form, as do the stresses, a second-rank symmetric tensor. The number of independent parameters of this « piezospectroscopic » tensor is two for tetragonal and trigonal, three for rhombic, four for monoclinic and six for triclinic centers (see Fig. 2C). The shifts of the splitted spectral line components are expressed through these parameters.

The components of a strain-splitting spectral line are generally strongly polarized. The obvious reason for this lies in the fact that these components are connected with transitions in individual groups of the centers which absorb and emit light anisotropically. Calculations show that the polarization of components depends uniquely on the multipolarity of transition and on the shape and orientation of the optical oscillator in the center (see Fig. 4).

Thus an investigation of the strain splitting in the spectra permits to determine the following properties of noncubic centers :

1. The actual type to which the center of interest belongs, i. e. the class of symmetry and the orientation of the center in the lattice. This characteristic is directly connected with the geometric structure of the center and provides a reliable criterion in the selection of physical models of centers.

2. The piezo-spectroscopic tensor for the spectral line which characterizes quantitatively the effect of elastic strain in the lattice on the center levels, as well as permits to predict the line shift at hydrostatic pressure.

3. The multipolarity of transition for the spectral line and the equivalent oscillator characterizing nonzero matrix elements of the dipole moment for the transition. These data are essential for the knowledge of the symmetry properties and of the nature of electron levels in a center.

We have considered here line splitting due to different shift of center levels and to the strain-induced lifting of the orientational degeneracy. The pattern can become still more complicated due to the splitting of orbitally — degenerate electron levels of individual

Component polarization	Orientation of polarization	Tetragonal				Trigonal				Rhombic I				Rhombic II		Monoclinic I				Monoclinic II				
		π_e	σ_e	π_m	σ_m	π_e	σ_e	π_m	σ_m	$\pi_e^{<110>}$	$\sigma_e^{<110>}$	$\pi_m^{<110>}$	$\sigma_m^{<110>}$	π_e	π_m	π_e	σ_e	π_m	σ_m	π_e	σ_e	π_m	σ_m	
$\langle 100 \rangle$	$E \parallel P$																							
	$E \perp P$																							
$\langle 111 \rangle$	$E \parallel P$																							
	$E \perp P$																							
$[110]$	$E \parallel [110]$																							
	$E \perp P$																							
	$E \parallel [1\bar{1}0]$																							
	$E \perp P$																							

FIG. 4. — Intensity and polarization of components of the noncubic center line-splitting resulting from the strain-induced lifting of orientational degeneracy.

centers as a result of a further lowering of the center symmetry caused by strain. Such doubly-degenerate levels (*E*) exist in tetragonal and trigonal centers. The strain-induced line splitting for transitions involving these levels was considered theoretically by Runciman [13] who took into account the splitting of these levels.

A large number of papers have been devoted to an experimental study of the strain-induced line splitting in the spectra of noncubic centers [13-29]. In our group we studied mainly activated crystals (fluorite containing rare-earths [12, 20], alkali fluorides with uranyl [19]) and colored lithium fluoride [12, 22]. The research on color centers where the piezospectroscopic method proved to be very useful [12, 21-29] is reviewed at this Conference in a special report by Dr. Hughes. I shall restrict myself here only to one work carried out by Moskvina and myself [22].

We studied a nonidentified zero-phonon luminescence line at 5 240 Å of colored lithium fluoride which has also a resonance analog in absorption. In figure 5 is shown the line splitting under compression along the $\langle 100 \rangle$, $\langle 111 \rangle$, $\langle 110 \rangle$ directions in the light with polarizations $E \parallel P$ and $E \perp P$. As is seen, the line yields polarized triplets under compression along $\langle 100 \rangle$ and $\langle 110 \rangle$, and is not splitted under compression along $\langle 111 \rangle$. The splitting pattern agrees completely with the predictions for rhombic centers II where all axes are parallel to the cube axes. If we assume the line to belong to an *F*-aggregate center, then the simplest model will be a center based on three nearest anion vacancies forming an isosceles rectangular triangle in the cube plane with the C_{2v} symmetry. All the other models satisfying the

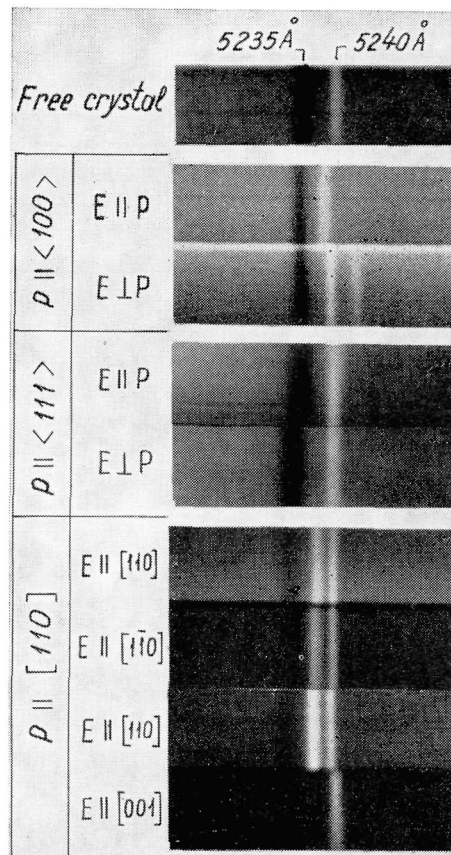

FIG. 5. — Strain-induced splitting of zero-phonon luminescence line of colored LiF at 5 240 Å [22].

symmetry obtained appear much more complicated and artificial. The stability and the conditions for formation of the λ 5 240-center have not been studied

in detail, and it is unknown to what extent they agree with the above model.

LINEAR STARK EFFECT IN NONCUBIC CENTER SPECTRA. — The action of an external electric field on the electron levels of noncubic centers depends, in the first place, on the inversion center symmetry. If the point symmetry group of a center contains an inversion, then the matrix elements of the «odd» perturbation which in this case is the external electric field ϵ , will vanish for the individual electron levels of the center possessing a definite parity. The field can thus reveal itself only in the second order of the perturbation theory, yielding a quadratic shift or level splitting. At the same time, if the center symmetry does not contain inversion, the external field can produce a linear Stark effect on center levels.

The first to draw attention to a possibility of a linear Stark effect in the optical spectra of inversionless centers were apparently Overhauser and R  chardt [31] in 1958. They studied the effect of an electric field

on broad bands of *M*- and *R*-color centers in KCl and NaCl in order to shed light on the inversion center symmetry. Recently the linear Stark effect was observed experimentally in the spectra of a number of uniaxial crystals including ruby [32, 33].

Many essential properties of the linear Stark effect in the spectra of inversionless noncubic centers in cubic crystals are determined solely by the symmetry of the centers and of their electron levels. These properties have been studied in my recent work carried out together with Dr. Medvedev [35] using group-theoretical methods and the phenomenological perturbation theory.

Consider at first the effect of the field on the levels of individual centers. In table 4 there are listed all noncubic inversionless centers which can exist in O_h crystals, as well as their levels characterized by irreducible representations of center groups. Column 3 contains expressions for the linear shift and level splitting in electric field for all levels. In groups with

TABLE 4

Center	Levels	Linear Stark Effect
C_1	A, E'	$A_x \epsilon_x + A_y \epsilon_y + A_z \epsilon_z$
C_s	A', A'', E'	$A_x \epsilon_x + A_y \epsilon_y$
C_2	A, B, E'	$A\epsilon_{ }$
C_3	A, E'_1, E'_2 E	$A\epsilon_{ }$ $A\epsilon_{ } \pm B\epsilon_{\perp}$
C_{3v}	A_1, A_2, E'_1, E'_2 E	$A\epsilon_{ }$ $A\epsilon_{ } \pm B\epsilon_{\perp}$
D_3	A_1, A_2, E'_1, E'_2 E	0 $\pm B\epsilon_{\perp}$
C_{2v}	A_1, A_2, B_1, B_2, E'	$A\epsilon_{ }$
D_2	A_1, B_1, B_2, B_3, E'	0
C_4	A, B, E, E'_1, E'_2	$A\epsilon_{ }$
S_4	A, B, E'_1, E'_2 E	0 $\pm B\epsilon_{ }$
C_{4v}	$A_1, A_2, B_1, B_2, E, E'_1, E'_2$	$A\epsilon_{ }$
D_4	$A_1, A_2, B_1, B_2, E, E'_1, E'_2$	0
D_{2d}	$A_1, A_2, B_1, B_2, E'_1, E'_2$ E	0 $\pm B\epsilon_{\perp}$

one selected symmetry axis the electric field components ε_{\parallel} and ε_{\perp} are taken with respect to this axis. The phenomenological parameters determining the magnitude of the effect are denoted by A for the shift and by B for the line splitting. Zero indicates absence of the linear effect for levels.

As seen, there is no linear effect at all for some inversionless centers (D_2 , D_4) and for many levels of other centers (D_3 , S_4 , D_{2d}). In the case of centers with a selected rotational symmetry axis (C_2 , C_{2v} , C_3 , C_{3v} , C_4 , C_{4v}) the linear level shift is caused only by the projection of the field on the axis of the centers. The splitting of the doubly-degenerate E -level in trigonal centers is determined by the projection of the field on the plane normal to the axis of the centers. The splitting of the doubly-degenerate E -level in tetragonal centers occurs only in the case of centers with mirror-rotational axis (S_4 , D_{2d}) and is determined by the projection of the field on this axis. Thus the action of electric field on the levels of noncubic centers is strongly anisotropic.

When considering the effect of electric field on crystal spectra, one should take into account the orientational degeneracy of centers. The axes of centers belonging to different groups make different angles with the external field, and hence they experience different action from the field. Similar to the case of strain-induced splitting, there can occur here a splitting of spectral lines due only to a lifting of the orientational degeneracy of centers in the field and to a different shift of levels and of transition frequencies for centers with different orientation (the so-called « pseudostark » splitting [32]). There can occur also an additional line splitting caused by a real field-induced splitting of doubly-degenerate electron levels in trigonal and tetragonal centers. All these cases have been considered in reference [35] containing calculations of the number of the splitting components, of their polarization and relative intensity, as well as of the relative shifts of components with the field acting parallel to the $\langle 100 \rangle$, $\langle 111 \rangle$ and $\langle 110 \rangle$ directions in a crystal.

A number of characteristic general features of the linear Stark effect are seen on spectrograms showing field-induced pseudostark splitting of the lines of trivalent cerium embedded in the fluorite lattice. As shown earlier by the piezospectroscopic technique [20], the ions are situated in local fields of different-tetragonal and trigonal-symmetry which are due to the presence of compensating defects near cerium ions (Fig. 6). These experiments in which linear Stark splitting in the spectra of cubic crystals was apparently

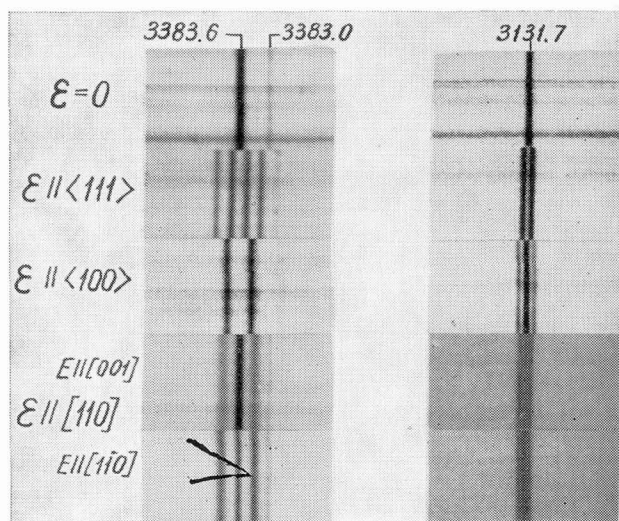

FIG. 6. — Linear pseudo-Stark splitting of $f-d$ absorption lines in $\text{CaF}_2 - \text{Ce}^{3+}$.

observed for the first time [34, 35] have yielded valuable information on rare-earth centers. In figure 6 one can easily see a strong dependence of the splitting pattern on the center symmetry and on field orientation in the crystal. One can also see that the components are polarized.

Note that the pattern of linear splitting turns out to be symmetric in all cases with respect to the position of the spectral line in a free crystal. This indicates that the pattern does not depend on the sign of the field despite the linear character of splitting. This independence is only natural for a O_h centrosymmetric crystal and is due to the fact that for each orientation of the center there always exists another orientation, differing in inversion, for which the action of external field will be just opposite in sign.

A study of the linear Stark effect permits, in the first place, to obtain information concerning the properties of the inversion symmetry of centers which cannot be gained by optical means which do not make use of electric field. However the class of symmetry and the orientation of centers in the lattice quite often cannot be determined here just as unambiguously as in piezospectroscopic investigations. It is only natural since the strain-induced splitting is determined by a second-rank tensor (ellipsoid) which is more « sensitive » to symmetry properties, whereas the pseudostark splitting is determined by the vector of the dipole moment which can be oriented in the same way with centers of different symmetry. From the polarization properties of the Stark splitting one can derive also the multipolarity of optical transitions,

and in some cases also optical oscillators for the lines.

Recently we together with Medvedev have succeeded in observing linear Stark effect on zero-phonon lines of color centers in lithium fluoride [30]. The spectrogram of figure 7 shows a small polarized splitting of

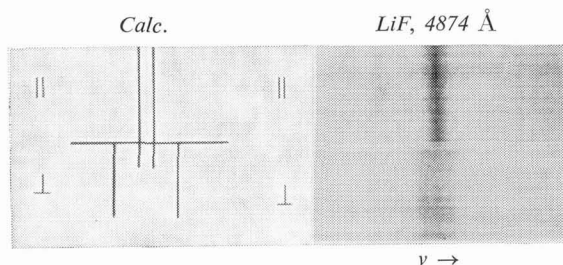

FIG. 7. — Polarized splitting of λ 4 874 zero-phonon absorption line of colored LiF in an electric field $\parallel < 100 >$.

the λ 4 874 absorption line with an electric field along $< 100 >$. The magnitude of splitting constitutes about 1.8 cm^{-1} at 100 kV/cm. According to various publications [25, 36] including piezospectroscopic studies, this line belongs to a transition $A \rightarrow E$ between the ground nondegenerate and upper doubly-degenerate levels in an ionized F_3 -center. The trigonal symmetry of the center (C_{3v}) does not contain inversion, so that application of a field can result in a linear level shift and splitting of the upper degenerate level. Because of an orientational degeneracy of centers in the field $\epsilon_{\parallel} < 100 >$, one should observe a polarized quartet shown in the figure. The observed pattern of triplet splitting agrees with calculations if one assumes the middle component of the triplet to be an unresolved double line.

One could also establish a very weak field-induced broadening of the R_2 -line at 391 nm belonging to inversionless R -centers. The field does not affect in any way the λ 5 234 line of N_1 -centers which, generally speaking, can be considered as evidence for the inversionless models of centers.

A large Stark effect was observed on one of nonidentified long wavelength zero-phonon absorption lines of colored lithium fluoride at 6 955 Å. Figure 8 shows the line splitting caused by application of strain and by electric field along $< 100 >$. It is seen that the number of the pseudostark splitting components (a triplet) exceeds that of the strain-induced components (a doublet). This usual situation is due to the additional effect of the field which makes nonequivalent those centers whose orientation differs only in inversion and which experience the same perturbation under strain and yield one component in the stress-spectrum. The magnitude of the pseudostark splitting constitutes about 4 cm^{-1} at

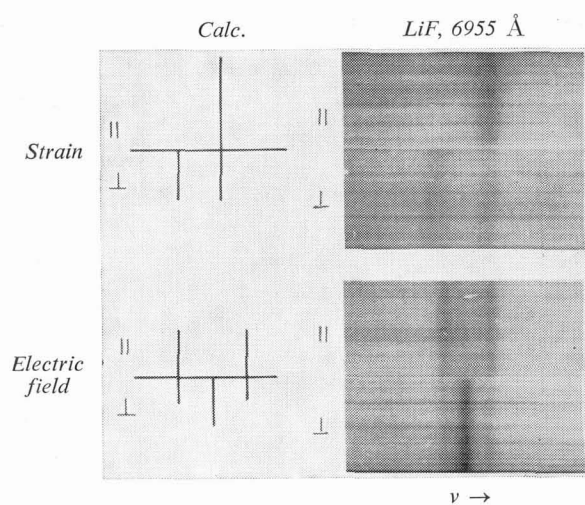

FIG. 8. — Polarized splitting of λ 6 955 absorption line of colored LiF under strain and in external electric field applied along $< 100 >$.

100 kV/cm. These patterns of the strain-induced and pseudostark splittings indicate that the corresponding inversionless centers have rhombic I or monoclinic I symmetry. The actual model of the center can apparently be considered after a further study of the properties of the nonidentified line at 6 955 Å whose description we have not been able to find in publications on lithium fluoride.

ZEEMAN-SPLITTING IN THE SPECTRA OF CENTERS. —

The anisotropy in the g -factors of the levels of noncubic centers results apparently in the spectrum of centers in a magnetic field representing a superposition of the spectra of centers with different orientation relative to the field. Arkhangelskaya and Feofilov [37] have calculated the Zeeman splitting for a number of simple cases. An analysis of the Zeeman pattern permits in principle to determine the symmetry of centers and of their levels as well as the multipolarity of transitions. It should be noted that in contrast to the strain — and electric field — induced splittings, the line splitting in a magnetic field is always connected with the splitting of levels of individual centers. Therefore the Zeeman technique is applicable only to the study of noncubic centers with degenerate levels. It cannot be used, for instance, for the investigation of noncubic centers with rhombic, monoclinic and triclinic symmetry which possess an even number of electrons, since the levels of such centers are always nondegenerate. Experimental observations of the Zeeman splitting in the spectra of noncubic centers are scarce and they concern mainly activated crystals [18, 37, 38]. The effect of magnetic field on zero-phonon lines of complex color centers was studied by several

authors [25, 39, 40], however, as far as we know, no line splitting has been observed up to now.

Now a concluding remark. In the above consideration of the spectroscopic effects of external fields there was made an assumption that the distribution of centers in all possible orientations remains uniform in external fields just as in the case of a free crystal, which holds for many centers. All groups of centers are in this case represented in the optical spectrum by their components. However in a number of cases the physical structure of a noncubic center permits its relatively easy reorientation. An external action renders different orientations of centers energetically nonequivalent, and as a result the centers assume preferential orientation corresponding to the lowest energy possible, in accordance with the Boltzmann distribution. The reorientation of centers results in a number of very interesting phenomena which have been studied in detail under application of both stress and electric field by Watkins, Känzig, Corbett, Luty and other authors [41]. As a result of such preferential orientation of centers, only those components which correspond to energetically advantageous orientations remain in the spectrum. Dichroism is usually observed here because of polarization of components. It should be noted that dichroism appears also in the case of splitting of individual center levels from which the transition takes place, where Boltzmann distribution over the sublevels is always realized. Dichroism often can be used to derive the character of splitting in the spectrum which is essential in cases where direct observation of the splitting cannot be readily carried out, for instance, because of a large width of the lines.

References

- [1] See, for example, FEOFILOV (P. P.) and KAPLYANSKII (A. A.), *Uspekhi fiz. Nauk*, 1962, **76**, 201.
- [2] KAPLYANSKII (A. A.), *Optika i Spektrosk.*, 1964, **16**, 602 (*Optics and Spectroscopy*, 1964, **16**, 329).
- [3] FEOFILOV (P. P.), Physical Basic of Polarized Emission, Cons. Bureau, N. Y., 1961.
- [4] NIKITINE (S.), *C. R. Acad. Sci.*, 1943, **213**, 32 ; 1943, **216**, 730, 758.
- [5] UETA (M.), *J. Phys. Soc. Japan*, 1952, **7**, 107.
- [6] FEOFILOV (P. P.), *Dokl. Akad. Nauk SSSR*, 1954, **98**, 949.
- [7] FEOFILOV (P. P.), *Dokl. Akad. Nauk SSSR*, 1953, **92**, 545, 743 ; *Zh. eksper. teor. Fiz.*, 1954, **26**, 609.
- [8] DELBECQ (C. J.), PRINGSHEIM (P.), *J. Chem. Phys.*, 1953, **21**, 794. PRINGSHEIM (P.), *Z. Physik*, 1954, **136**, 573.
- [9] KAPLYANSKII (A. A.), *Optika i Spektrosk.*, 1959, **6**, 424 (*Optics and spectroscopy* 1959, **6**, 267).
- [10] OSTEN (W. von der) and WAIDELICH (W.), *Naturwiss.*, 1962, **49**, 342.
- [11] FITCHEN (D. B.), SILSBEE (R. H.), FULTON (T. A.), WOLF (E. L.), *Phys. Rev. Letters*, 1963, **11**, 275.
- [12] KAPLYANSKII (A. A.), *Optika i Spektrosk.*, 1959, **7**, 677, 683 (*Optics and spectroscopy* 1959, **7**, 406, 409).
- [13] RUNCIMAN (W. A.), *Proc. Phys. Soc.*, 1965, **86**, 629.
- [14] SCHAWLOW (A. L.), *J. Appl. Phys. Suppl.*, 1962, **33**, 395.
- [15] RUNCIMAN (W. A.), STAGER (C. V.), CROZIER (M. H.), *Phys. Rev. Lett.*, 1963, **11**, 204.
- [16] LUDLOW (I. K.), RUNCIMAN (W. A.), *Proc. Phys. Soc.*, 1965, **86**, 1081.
- [17] SHATAS (R. A.), TANTON (G. A.), STETTLER (J. D.), *Phys. Letters*, 1966, **23**, 70.
- [18] CROZIER (M. H.), *Phys. Rev.*, 1965, **137**, A 1781.
- [19] KAPLYANSKII (A. A.) and MOSKVIN (N. A.), *Optika i Spektrosk.*, 1962, **13**, 542 ; 1963, **14**, 676. *Dokl. Akad. Nauk SSSR*, 1963, **148**, 558.
- [20] KAPLYANSKII (A. A.), MEDVEDEV (V. N.), *Optika i Spektrosk.*, 1965, **18**, 803.
- [21] KAPLYANSKII (A. A.), MOSKVIN (N. A.), PRZHEVUSKII (A. K.), *Optika i Spektrosk.*, 1961, **10**, 368 (*Optics and spectroscopy*, 1961, **10**, 185).
- [22] KAPLYANSKII (A. A.) and MOSKVIN (N. A.), *Optika i Spektrosk.*, 1965, **18**, 882.
- [23] LANZL (F.) and OSTEN (W. von der), *Phys. Letters*, 1965, **15**, 208.
- [24] SILSBEE (R. H.), *Phys. Rev.*, 1965, **138**, A 180.
- [25] HUGHES (A. E.) and RUNCIMAN (W. A.), *Proc. Phys. Soc.*, 1965, **86**, 615.
- [26] JOHANNSSON (G.), LANZL (F.), OSTEN (W. von der), WAIDELICH (W.), *Phys. Letters*, 1965, **15**, 110. BAUMANN (G.), OSTEN (W. von der) and WAIDELICH (W.), *Phys. Letters*, 1966, **20**, 579.
- [27] HUGHES (A. E.), *Proc. Phys. Soc.*, 1966, **87**, 535.
- [28] STILES (L. F.), FITCHEN (D. B.), *Phys. Rev. Letters*, 1966, **17**, 689.
- [29] HUGHES (A. E.), *Sol. State Comm.*, 1966, **4**, 337.
- [30] KAPLYANSKII (A. A.) and MEDVEDEV (V. N.), *Zh. eksper. teor. Fiz.*, Pisma, in press.
- [31] OVERHAUSER (A. W.), RUCHARDT (H.), *Phys. Rev.*, 1958, **112**, 722.
- [32] KAISER (W.), SUGANO (S.) and WOOD (D. L.), *Phys. Rev., Letters*, 1961, **6**, 605.
- [33] COHEN (M. G.) and BLOEMBERGEN (N.), *Phys. Rev.*, 1964, **135**, A 950.
- [34] KAPLYANSKII (A. A.) and MEDVEDEV (V. N.), *Optika i Spektrosk.*, in press.
- [35] KAPLYANSKII (A. A.) and MEDVEDEV (V. N.), *Zh. eksper. teor. Fiz.*, Pisma, 1965, **2**, 209.
- [36] FARGE (Y.), TOULOUSE (G.) and LAMBERT (M.), *J. Physique*, 1966, **27**, 287.
- [37] ARKHANGELSKAYA (V. A.) and FEOLIFOV (P. P.), *Optika i Spektrosk.*, 1958, **4**, 602.
- [38] ZAKHARTCHENYA (B. P.), RUSANOV (I. B.) and TACHISTOVA (I. I.), *Fiz. Tverdogo Tela.*, 1966, **8**, 3602.
- [39] JOOS (G.) and RITZ (H.), *Verh. dtsh. phys. Ges.*, 1956, **7**, 101.
- [40] CROZIER (M. H.), *J. Chem. Phys.*, 1964, **41**, 1510.
- [41] See, for example, CORBETT (J. W.) and WATKINS (G. D.), *J. Phys. Chem. Solids*, 1961, **20**, 319 ; KÄNZIG (W.), *J. Phys. Chem. Solids*, 1962, **23**, 479 ; KUHN (V.) and LÜTY (F.), *Sol. St. Comm.*, 1964, **2**, 281.