



HAL
open science

An application of the optical microscopy to the determination of the curvature elastic modulus of biological and model membranes

I. Bivas, P. Hanusse, P. Bothorel, J. Lalanne, O. Aguerre-Chariol

► **To cite this version:**

I. Bivas, P. Hanusse, P. Bothorel, J. Lalanne, O. Aguerre-Chariol. An application of the optical microscopy to the determination of the curvature elastic modulus of biological and model membranes. *Journal de Physique*, 1987, 48 (5), pp.855-867. 10.1051/jphys:01987004805085500 . jpa-00210505

HAL Id: jpa-00210505

<https://hal.science/jpa-00210505v1>

Submitted on 4 Feb 2008

HAL is a multi-disciplinary open access archive for the deposit and dissemination of scientific research documents, whether they are published or not. The documents may come from teaching and research institutions in France or abroad, or from public or private research centers.

L'archive ouverte pluridisciplinaire **HAL**, est destinée au dépôt et à la diffusion de documents scientifiques de niveau recherche, publiés ou non, émanant des établissements d'enseignement et de recherche français ou étrangers, des laboratoires publics ou privés.

Classification
 Physics Abstracts
 82.70

An application of the optical microscopy to the determination of the curvature elastic modulus of biological and model membranes

I. Bivas ⁽¹⁾, P. Hanusse, P. Bothorel ⁽²⁾, J. Lalanne and O. Aguerre-Chariol

Centre de Recherche Paul Pascal (C.N.R.S.), Domaine Universitaire, 33405 Talence Cedex, France

(Reçu le 5 mai 1986, révisé le 12 décembre, accepté le 22 décembre 1986)

Résumé. — On présente une nouvelle méthode permettant de mesurer le module d'élasticité de courbure de la membrane à partir des fluctuations thermiques de la forme d'une vésicule sphérique. Des liposomes ont été observés sous microscope travaillant au régime de contraste de l'interférence différentielle de Nomarski. Nous montrons que la valeur ainsi mesurée de k_c est celle du flip-flop libre.

Abstract. — A new method is proposed to measure the curvature elastic modulus k_c of a membrane, by observing the thermal induced fluctuations of the shape of a spherical vesicle. Observations of the liposomes were carried out under a microscope working in the regime of Nomarski differential interference contrast. We show that the value of k_c thus measured is the curvature elastic modulus of free flip-flop.

1. Introduction.

Nowadays the liquid crystal approach is considered as one of the most powerful to explain the properties of biological and model lipid membranes. In its earliest form this approach was proposed by Bothorel and Lussan [1-3], Ambrose *et al.* [4] and Ferguson and Brown [5]. Later on it was developed and completed by Singer and Nicolson [6], Sackmann [7], Chapman and Wallach [8] and by many others (for review on this problem see [9]). The liquid crystal approach considers the long-range order in the positions of the hydrophilic and hydrophobic groups of the amphiphilic molecules building up the membranes. A biological membrane is described as a two-dimensional liquid composed of lipids, in which integral proteins are embedded. This concept naturally supposes that the mechanical properties of membranes can be treated in the same way as those of liquid crystals. Energy is required to change their surface area and their curvature. Helfrich [10, 11] considers the membrane as an infinitely thin layer which can be characterized by its surface area S and by the principal curvatures c_1 and c_2 in each point.

The free energy density of curvature g_c per unit area of the layer is proposed by him in the form :

$$g_c = \frac{1}{2} k_c (c_1 + c_2 - c_0)^2 + \bar{k}_c c_1 c_2 \quad (1)$$

where k_c and \bar{k}_c are the curvature elastic modulus and the saddle splay curvature elastic modulus, and c_0 is the spontaneous curvature, which is different from zero when the two sides of the membrane are not equivalent. These moduli correspond to the moduli K_{11} and K_{24} in Frank's theory of elasticity of nematic liquid crystals down to a length which is here the membrane thickness. Historically the first evaluations of k_c were obtained by using the moduli of nematics. In fact, this modulus is more closely related to those of smectics. There has been a number of attempts to evaluate them on the basis of molecular models (for a review of recent results see [9]). The experiments concerning this problem have been designed to measure these moduli directly. The analogy with liquid crystals is evident. One of the first experimental determinations of the elastic moduli of nematic liquid crystals consisted in the measurement of the light scattering properties due to local fluctuations of the director of the liquid crystal [12]. The amplitude of these fluctuations is connected with the elastic moduli of the crystal. The situation is similar with membranes : they undergo

⁽¹⁾ On leave from the Institute of Solid State Physics, Bulgarian Academy of Sciences, Liquid Crystal Group, 72 Lenin Blvd, Sofia 1184, Bulgaria.

⁽²⁾ To whom all correspondence should be addressed.

out-of-plane thermal fluctuations whose amplitude depends on their curvature elastic modulus. This phenomenon was discovered about 100 years ago [13] in erythrocytes and is known as a flicker phenomenon. Brochard and Lennon [14] proposed a theoretical model for determining the curvature elastic modulus of the erythrocyte membrane by measuring the time and space correlation functions of the flicker intensities at different points of the cell surface. The value of k_c they found is $\approx (1.3-3) \times 10^{-13}$ erg for the human erythrocyte. The same method was used by Fricke and Sackmann [15], their aim being not particularly to measure k_c but rather to determine the form of the correlation function (i.e. to verify the bases of the theory proposed in [14]). The same objective (curvature elastic modulus of red blood cell membrane) was aimed at by Evans [16]. In his experiment the erythrocyte was aspirated in a micropipette and the critical pressure of aspiration, when buckling instability appears, was measured. The theoretical treatment shows that in this experiment only the curvature elasticity (and not the shear elasticity) is responsible for the onset of instability. The value of k_c obtained by Evans is considerably higher: 1.8×10^{-12} erg. Servus *et al.* [17] were the first to examine the curvature elastic modulus of a bilayer of egg-yolk lecithin (all the data cited later on in the introduction concern the unilamellar bilayer lipid membrane). They observed under microscope the fluctuations of tube-like vesicles consider as one-dimensional objects whose curvature elastic modulus is expressed *via* the curvature elastic modulus of the membrane and the radius of the tube. Only tubes which are planar (lying entirely in the plane of observation of the microscope) were recorded. The measured value was $k_c = (2.3 \pm 0.3) \times 10^{-12}$ erg. Using the same method, Beblík *et al.* [18] measured k_c for some synthetic lecithins: DMPC (2.4×10^{-12} erg, $T = 26.0$ °C), DPPC (2.0×10^{-12} erg, $T = 44$ °C), DSPC (1.8×10^{-12} erg, $T = 56.5$ °C) and egg-lecithin (2.0×10^{-12} erg, $T = 24.0$ °C). Sakurai and Kawamura [19], slightly modifying this technique (the myelinic figures [18] of the lecithin, among which the tube like vesicles were chosen, were obtained in the lecithin/water system under magnetic field) measured a value of k_c of 4×10^{-13} erg. Schneider *et al.* [20] also studied tube like vesicles. They investigated the correlation function of the displacement of the middle point of the tube with respect to the middle point of the segment, connecting the ends of the tube. Their value of k_c was $(1-2) \times 10^{-12}$ erg. Recently Schneider *et al.* [21] measured the correlation function in the fluctuations of the shape of large quasispherical vesicles of egg-yolk lecithin. The result of their study gave $k_c = (1.5 \pm 0.5) \times 10^{-12}$ erg. Using the theoretical treatment of [21], Engelhart *et al.* [22] proceed from the mean square

amplitudes of the circular harmonics of the equatorial cross-section of the vesicle. Although the result is not the same for all harmonics, then conclude that the significant values for k_c (for the lowest harmonics) are grouped around $(3-6) \times 10^{-13}$ erg for the liposomes of DMPC, and the mixtures DMPC + cholesterol and DMPC/DPPC.

This short review of the experimental results concerning the curvature elastic modulus k_c shows that up to now this quantity is known with little precision even for objects as typical as lipid bilayers and erythrocyte membrane. The situation is still more undetermined with respect to the saddle splay curvature elastic modulus \bar{k}_c (when even its sign is not determined unequivocally) and the spontaneous curvature c_0 .

The aim of the present work is to propose an additional method, based on optical microscopy, for the measurement of the quantity k_c , using the thermal fluctuations of giant (of the order of $10 \mu\text{m}$) quasi-spherical vesicles. We have observed these fluctuations under a microscope working in the regime of Nomarski Differential Interference Contrast. This regime has a very high resolution, but it introduces optical deformations and it shows only part of the object under observation. Having in mind both the possibilities and limitations of the apparatus available, we have analysed the fluctuations of the shape of the vesicle by application of a theoretical model which is presented below.

2. Theory.

Our theoretical approach is based on the considerations of Schneider *et al.* [21] and Engelhart *et al.* [22]. The membrane is considered as a two-dimensional liquid, characterized by its curvature elastic moduli k_c , \bar{k}_c and c_0 . The vesicle is characterized by its volume V . The number of amphiphilic molecules building up the membrane of the vesicle is such that the chemical potential per molecule is minimized (this corresponds to the situation when the lateral tension of the membrane is zero). We note that in the chemical potential, the energy of curvature must also be included, as it is necessary for the formation of the closed two-dimensional surface of the membrane (the surface surrounding the volume V) as well as for the determination of the mean energy of thermal curvature fluctuations. Let us consider a hypothetical state of the vesicle, with temperature $T = 0$ K, and in which the curvature elastic moduli and the surface area do not change (later on, when stating that $T = 0$, we shall be referring to this state). When $T = 0$, the equilibrium form of the vesicle is not always spherical [23-25]. This is the case when the spontaneous curvature c_0 is different from zero (e.g. the ghost red blood cell membrane) and/or the hydrostatic pressure inside

and outside the membrane are different, the difference between them being larger than some threshold. In what follows we shall only consider symmetrical membranes (i.e. with $c_0 = 0$) with equal hydrostatic pressures, inside and outside the vesicle. Under these conditions, when $T = 0$, the vesicle will be spherical. At non zero temperature the membrane fluctuates. We suppose that the temperature is low enough so that the fluctuations are quite small. This is why our method can only measure a high enough curvature elastic modulus (the quantitative expression of this condition will be given later). We could consider fluctuations as perturbations of the spherical form of the volume V . For given values of the temperature and k_c , this volume is such that the pressure difference across the membrane vanishes. The dependence of V on T and k_c will be discussed later. The condition that V remains constant corresponds to the very realistic assumption that the liquid inside the vesicle is incompressible and that there is no exchange of the liquid between the interior and exterior. We also suppose that, after the vesicle attains its equilibrium, there is no exchange of amphiphilic molecules between the membrane and the solvent.

We introduce a reference frame XYZ , whose origin O coincides with the centre of mass of the volume V . Let us consider the direction characterized by the polar angles (θ, ψ) . In what follows we shall suppose that never more than one point of the membrane $M(\theta, \psi)$ can be found in this direction. We denote the distance between O and M by $\rho(\theta, \psi)$, and define the quantity $u(\theta, \psi, t)$, where t is time, as :

$$u(\theta, \psi, t) = \rho(\theta, \psi, t) - R \tag{2}$$

where R is the radius of the sphere with volume V . It will be shown that the mean square value of $u(\theta, \psi, t)$ depends on k_c . We suppose that k_c is large enough so that the inequality

$$u(\theta, \psi, t) \ll R \tag{3}$$

is practically always valid.

The curvature at each point of the deformed vesicle can be expressed in terms of the quantity $u(\theta, \psi, t)$. If

$$c(\theta, \psi, t) = c_1(\theta, \psi, t) + c_2(\theta, \psi, t),$$

where c_1 and c_2 are defined in expression (1), the relation between $c(\theta, \psi, t)$ and $u(\theta, \psi, t)$ is (Schneider *et al.* [22]) :

$$c(\theta, \psi, t) = -\frac{2}{R} + 2\frac{u(\theta, \psi, t)}{R} + \nabla^2 u(\theta, \psi, t) \tag{4}$$

where ∇^2 is the polar part of the Laplacian. In order to keep the notation used in [21], we assume that the curvature is negative, when the centre of the vesicle

and the centre of the curvature are on the same side of the membrane. The quantity $u(\theta, \psi)$ can be decomposed into spherical harmonics $Y_m^n(\theta, \psi)$ [21] :

$$u(\theta, \psi, t) = \sum_{\substack{n=2,3,\dots,n_{\max} \\ m=0,\pm 1,\pm 2,\dots,\pm n}} u_m^n(t) Y_m^n(\theta, \psi) \tag{5}$$

$$Y_m^n(\theta, \psi) = \frac{1}{\sqrt{2\pi}} e^{-im\psi} P_m^n(\theta) \tag{6}$$

$$n_{\max} \approx \frac{\pi R}{s_0^{1/2}} \tag{7}$$

where $P_m^n(\theta)$ are the normalized Legendre polynomials and s_0 is the mean surface area per molecule in the membrane.

The sum over n begins at $n = 2$, and not $n = 0$, because if the mode $n = 0$ were different from zero, the volume V would not be conserved, and if the mode $n = 1$ were different from zero, the centre O of the frame XYZ would not coincide with the centre of mass of the volume V .

Assuming as in [21] that all modes are independent, we can express the mean values $\langle |u_m^n(t)|^2 \rangle$ in terms of the temperature, the curvature elastic modulus and the radius of the vesicle. Angle brackets stand for time average.

The final result is [21] :

$$\langle |u_m^n(t)|^2 \rangle = \frac{kTR^2}{k_c(n-1)^2(n+2)^2} \tag{8}$$

where k is the Boltzmann constant.

Let us consider the equatorial cross-section of the vesicle with plane XY . It represents a deformed circle, which would have radius R if not perturbed. The amplitudes of fluctuations of this contour in the plane XY can be characterized by $u(\pi/2, \psi, t)$, where $u(\theta, \psi, t)$ is given in (5). We denote :

$$v(\psi, t) = u(\pi/2, \psi, t). \tag{9}$$

Following Engelhart *et al.* [22] we present $v(\psi, t)$ in the form :

$$v(\psi, t) = \sum_{q=-q_{\max}}^{q_{\max}} v_q(t) e^{-iq\psi};$$

$$v_q(t) = 1/2 \pi \int_0^{2\pi} v(\psi, t) e^{iq\psi} d\psi \tag{10}$$

$$q_{\max} \approx n_{\max} = \frac{\pi R}{s_0^{1/2}}.$$

After some algebra :

$$v_q(t) = 1/2 \pi \sum_{\substack{m=0,\pm 1,\dots,\pm n \\ n=1,2,\dots,n_{\max}}} u_m^n(t) \times \int_0^{2\pi} Y_m^n(\pi/2, \psi) e^{iq\psi} d\psi. \tag{11}$$

But within the framework of the approximations that we use, it follows that there is no correlation between the amplitudes of the spherical harmonics :

$$\langle u_m^n(t) x | u_{m'}^{n'}(t) |^* \rangle = \delta_{mm'} \delta_{nn'} \langle |u_m^n(t)|^2 \rangle. \quad (12)$$

From (11) and (12) :

$$\begin{aligned} \langle |v_q(t)|^2 \rangle &= \frac{1}{(2\pi)^2} \sum_{\substack{n=2,3,\dots,n_{\max} \\ m=0,\pm 1,\dots,\pm n}} \langle |u_m^n(t)|^2 \rangle_2 \times \\ &\times \left[\int Y_m^n \left(\frac{\pi}{2}, \psi \right) e^{-iq\psi} d\psi \right] \\ &\times \left[\int Y_m^n \left(\frac{\pi}{2}, \psi' \right) e^{iq\psi'} d\psi' \right] \\ &= \frac{k^2 TR}{2\pi k_c} \sum_{n=\max(2, |q|)}^{n_{\max}} \frac{\left[P_q^n \left(\frac{\pi}{2} \right) \right]^2}{(n-1)^2 (n+2)^2} \end{aligned} \quad (13)$$

where $q = 0, \pm 1, \dots, \pm n_{\max}$.

Let us define A_q as :

$$A_q = \sum_{n=\max(2, |q|)}^{n_{\max}} \frac{\left[P_q^n \left(\frac{\pi}{2} \right) \right]^2}{(n-1)^2 (n+2)^2}. \quad (14)$$

The values of A_q can be calculated numerically. The results for $|q| \leq 10$, with $n_{\max} = 16$, are given in table I. A_q converges very rapidly with n_{\max} , and the series (13) converges with q very rapidly. This is why in the numerical calculation, the precision obtained with these values of q_{\max} and n_{\max} is sufficient, and much higher than the experimental accuracy of our measurements.

As was mentioned in the introduction, our experimental set up shows only one part of the contour (two arcs, each one representing about 40 % of the contour). For this reason we cannot determine the values of the quantities $|v_q|^2$ for each contour. To overcome this difficulty, we use the fact that all points of the contour are equivalent. Let $f(\psi, t)$ be a function of the polar angle ψ connected with the fluctuations of the contour points. We denote :

$$\overline{f(\psi, t)} = \frac{1}{2\pi} \int_0^{2\pi} f(\psi, t) d\psi. \quad (15)$$

Because of the equivalence of contour points we have

$$\langle f(\psi, t) \rangle = \left\langle \frac{1}{\alpha - \beta} \int_{\alpha}^{\beta} f(\psi, t) d\psi \right\rangle \quad (16)$$

where α and β are arbitrary fixed angles (the result does not depend on α and β).

We choose to measure the function $\xi(\gamma)$ experimentally

$$\begin{aligned} \xi(\gamma) &= 1/R^2 \langle |v(\psi, t) + v(\psi + \pi, t)| \times \\ &\times |v(\psi + \gamma, t) + v(\psi + \gamma + \pi, t)| \rangle \end{aligned} \quad (17)$$

In the experiment only those contours were used, whose two arcs cover the intervals $[-\pi/4, \pi/4]$ and $[3\pi/4, 5\pi/4]$ entirely.

Table I. — Values of the coefficient A_q from (17) for $|q| \leq 10; n_{\max} = 16$.

$ q $	$A_q \times 10^4$
0	66.34
1	12.38
2	97.82
3	19.60
4	7.28
5	3.51
6	1.97
7	1.21
8	0.80
9	0.55
10	0.39

Because of property (16), $\xi(\gamma)$, for $\gamma < \pi/2$ can be represented as :

$$\begin{aligned} \xi(\gamma) &= \frac{1}{R^2} \times \\ &\times \left\langle \frac{1}{\pi/2 - \gamma} \int_{-\pi/4}^{\pi/4 - \gamma} [v(\psi, t) + v(\psi + \pi, t)] \right. \\ &\times [v(\psi + \gamma, t) + v(\psi + \gamma + \pi, t)] d\psi \left. \right\rangle. \end{aligned} \quad (18)$$

Expression (18) shows that $\xi(\gamma)$ can be experimentally measured. To this aim, having a large enough number of contours with arc amplitudes larger than intervals mentioned above, it is sufficient to calculate the integral between brackets in the right hand side of (18), and to average it over all contours. But from (17) and (13) $\xi(\gamma)$ can be calculated as :

$$\xi(\gamma) = \frac{kT}{2\pi k_c} \times \left\{ \sum_{n=2}^{n_{\max}} \sum_{m=n}^n \frac{2|1 + (-1)^m| \cos(m\gamma)}{(n-1)^2(n+2)^2} [P_m^n(\pi/2)]^2 \right\} = \frac{kT}{2\pi k_c} \left\{ \sum_{\substack{q=0 \\ q \text{ even}}}^{q_{\max}} \cos(q\gamma) \sum_{n=\max(2,q)}^{n_{\max}} \frac{4(1 - \delta_{0q}/2)}{(n-1)^2(n+2)^2} \times [(P_q^n(\pi/2))^2 + (P_{-q}^n(\pi/2))^2] \right\} \quad (19)$$

where δ is the Dirac symbol.

The numerical factor between braces in (19), with $n_{\max} = 16$ and $q_{\max} = 10$, is represented in figure 1. The same function with $q_{\max} = 2$ is given in the same figure, with dotted lines, the contribution of the modes $q = 0$ and $q = 2$ is much greater than that of the sum of all the other q -modes.

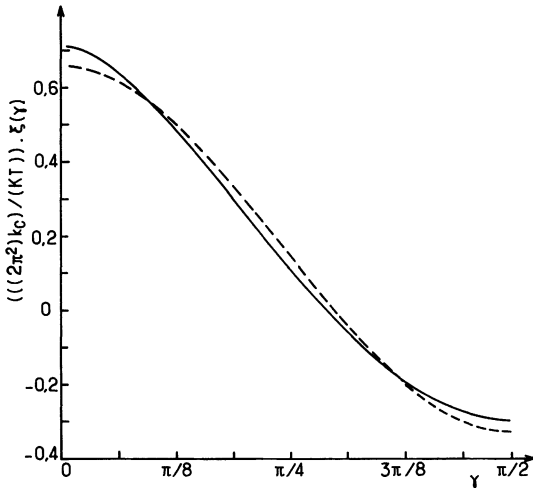

Fig. 1. — Numerical factor in the braces of the right hand side of formula (19) — multiplied by 2π —, calculated with $q_{\max} = 10$ (continuous line) and $q_{\max} = 2$ (dotted line); in both cases $n_{\max} = 16$.

The exact function $\xi(\gamma)$ can be expressed as a power series in the quantity kT/k_c . The first term of this series is given by (19). This justifies equation (4), which is in fact an approximation. Higher order terms $(k_m T/k_c)^m$, $m \geq 2$ could be added to expression (19).

According to the approximations used in [21], the amplitudes $u_m^n(\theta, \psi, t)$ are independent (12). Strictly speaking, this is entirely correct when the stretching elastic modulus k_s of the membrane is low enough. This is not the real situation. k_s has very high values and in the course of the fluctuation process the total surface area S of the vesicle membrane is kept practically constant. As a consequence, some correlation between the amplitudes of different modes

exists. We shall now that this correlation is always rather low.

Let us consider an imaginary flat membrane, having a surface area S and a very low stretching elastic modulus k_s , all other properties being those of a real membrane. Let V_1 be the volume of a vesicle formed with this membrane when the hydrostatic pressures inside and outside of the vesicle are equal. Let S_0 be the surface area of a sphere with volume V_1 . Let $S_1(t)$ be the time dependent surface area of the membrane corresponding to spherical harmonics with amplitudes $u_m^n(t)$. The difference $\Delta S = \langle S_1(t) \rangle - S_0$ can be calculated. Similar calculations have been carried out in [9] p. 455 for a slightly different geometry (flat tension free membrane with periodic boundary conditions, when the membrane sustains out-of-plane fluctuations). The result for ΔS in [9]:

$$\Delta S = \frac{kTS}{32\pi k_s} \ln \left[\left(\frac{1}{4} \frac{S}{s_0} \right)^{1/2} \right] \quad (20)$$

where s_0 is the mean area per molecule. For the imaginary vesicle ΔS must be the same, possibly corrected by a numerical factor of the order of unity. For the case when k_s is high enough (a real vesicle), we assume that $V = V_1$; consequently the surface of the sphere with volume V will be $S - \Delta S$ with ΔS from (20). For all fluctuation modes an excess surface ΔS is available (i.e. the vesicle is flaccid [22]). A given fluctuation mode should be practically uncorrelated with the others if the mean area of the « free » fluctuation of this mode (i.e. when k_s is low enough) is much less than ΔS . For the geometry used in [9] this mean area has been obtained as (Eq. (4.37a) in [9]):

$$\langle \Delta S_p \rangle = \frac{1}{2} \frac{kT}{k_c p^2} \quad (21)$$

where p is the wavelength of the p -mode. $\langle \Delta S_p \rangle$ is maximum for $p_{\min} = 2\pi/S^{1/2}$, that is

$$\langle \Delta S_{p \min} \rangle = \frac{kT}{8\pi^2 k_c} S. \quad (22)$$

Then:

$$\frac{\langle \Delta S_{p \min} \rangle}{\Delta S} = \frac{4}{\pi} \frac{1}{\ln \left[\left(\frac{1}{4} \frac{S}{s_0} \right)^{1/2} \right]}. \quad (23)$$

Note again that this result is obtained for the geometry defined in [9]. We assume that in the case of the spherical vesicle the ratio of the mean area for the lowest harmonics u_0^2 (whose surface area fluctuation is the greatest) to ΔS is practically the same. The value of this « worst case » ratio is 0.14, so that the approximation that the spherical harmonics are uncorrelated seems to be quite reasonable.

We shall now give a justification for the particular choice of the function $\xi(\gamma)$ that we measure.

Up to now, we always assumed that the centre of mass of the volume surrounded by the membrane is known, and that all measurements are made from this centre. But if only the cross-section with one plane is known, it is not possible to determine it. At best it is possible to determine the centre O_1 (properly defined) of the cross-section contour of the vesicle in that plane. A very exaggerated deformation illustrating the difference between these two centres is given in figure 2. If the centre O is fixed,

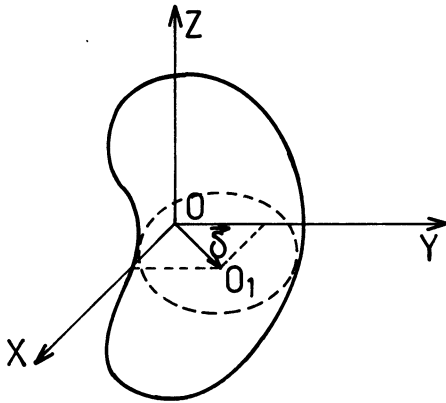

Fig. 2. — A very exaggerated deformed state of the vesicle. Point O is the centre of mass of the vesicle, and point O_1 is the centre of the contour of the cross-section of the vesicle with plane XY . $OO_1 = \delta$.

the average position of O_1 in time will coincide with O . But the vesicle as a whole undergoes a Brownian motion. If the liposome is considered as a solid, the mean value of displacement « b » due to this motion is :

$$\langle b^2 \rangle^{1/2} = \sqrt{\frac{2kT}{6\pi\eta R}} \sqrt{t} \quad (24)$$

where η is the viscosity of the medium ($\approx 0.01 p$ for water) and R the radius of the vesicle ($\approx 5 \mu m$). This means that the centre O changes considerably its position (about $1 \mu m$ after the first second). For the time of observation ($\approx 100 s$) the displacement of the centre is larger than the amplitude of fluctuations. Let δ be the vector connecting the centre of mass of the vesicle with some point O' with respect to which the radii $\rho(\psi)$ (see formula (21)) are measured. If $O' \equiv O_1$ (Fig. 2), $\langle |\delta(t)|^2 \rangle$ is of the order of the amplitude $\langle |v_1(t)|^2 \rangle$ from (16), i.e. of the order of kT/k_c . Consequently if the amplitudes $\langle |v_q(t)|^2 \rangle$, $q = 0, 1, 2 \dots q_{max}$ are measured using O_1 as a centre, corrections must be introduced, these corrections being greater than the fluctuations for $q > 2$.

We have calculated the relationship between

$\langle |\delta(t)|^2 \rangle$ and $\langle |v_q(t)|^2 \rangle$ when O' lies in the plane XY and $\langle |\delta(t)|^2 \rangle$ does not vanish, as :

$$\begin{aligned} \langle |v'_q(t)|^2 \rangle &= \langle |v_q(t)|^2 \rangle + \frac{\langle |\delta(t)|^2 \rangle}{R^2} \times \\ &\times \left[\frac{(q+1)}{4} \langle |v_{q+1}(t)|^2 \rangle + \frac{(q-1)^2}{4} \right. \\ &\times \left. \langle |v_{q-1}(t)|^2 \rangle + \left(q^2 - \frac{1}{4} \right) \langle |v_q(t)|^2 \rangle \right] \quad (25) \end{aligned}$$

where $|v_q(t)|$ are the true amplitudes, when $\langle |\delta(t)|^2 \rangle = 0$, and $|v'_q(t)|$ are the measured amplitudes when this equality does not hold.

Equation (13) allows us to calculate the value of k_c by measuring the quantities $\langle |v_q(t)|^2 \rangle$, and theoretically the result cannot depend on q . But because of the uncertainty in the centre position (which is expressed by $\langle |\delta(t)|^2 \rangle \neq 0$), for obtaining the real $|v_q|$, the system of infinite number of equations (25) must be solved. If relation (13) is applied directly using v'_q instead of v_q , from (25) it follows that the value of k_c obtained is not exact and should depend on q . This is the case with the data of Engelhart *et al.* [23]. When O' is fixed, because of the Brownian motion, $|\delta(t)|$ increases in time, the quantity $\langle |\delta(t)|^2 \rangle$ cannot be properly defined, and thus the measured values of k_c should depend on time t . Such an approach should be allowed only if the observations are made on a time scale during which the displacement due to the Brownian motion is much smaller than the fluctuation amplitude. This is not possible if the dimensions of the vesicle are of the order of $10 \mu m$.

To avoid most of these difficulties we work with the diameters of the contour instead of the radii (the quantities, taking part in (17) are fluctuations of the diameters). As can be seen from figure 3, the length

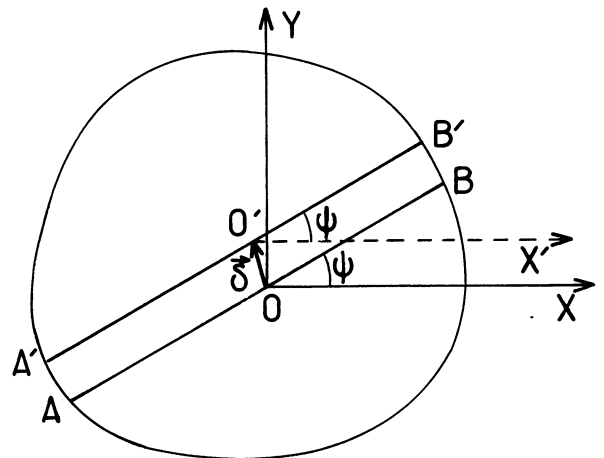

Fig. 3. — Cross-section of the vesicle in the plane XY . O — the centre of the vesicle, O' — the point with respect to which the radii are measured, $OO' = \delta$,

$$A'B' - AB = O \left| |\delta|^2 / R^2 \right|, \quad O'B' - OB = O \left| |\delta| / R \right|$$

A'B' (a diameter making angle ψ with the axis X) depends on the second and higher powers of $|\delta|/R$, while the radius $O'B'$, on the first power of this quantity. If we choose O' as the centre of the contour (i.e. $O' = O_1$ where O_1 is defined before equation (24)), $\langle |\delta(t)|^2 \rangle$ will be of the order of $R^2 kT/k_c$ (the fact that only one part of the contour is known does not change this order in $\langle |\delta(t)|^2 \rangle$). The corrections to $\xi(\gamma)$ due to the uncertainty in the centre position are of the order of $|(kT/k_c)^2|$, and they are negligible when k_c is high enough. Up to now we have implicitly assumed that $\delta(t)$ is not correlated with the fluctuations. Having the two arcs, which represent parts of the contour, we determine the circumference which best fits both arcs. Let us now define O_1 as the centre of the contour lying in the plane XY and having a radius R_1 . Let M be a point of the contour, and let the angle between O_1M and the axis x be ψ . We denote $O_1M = \rho_1(\psi)$, and choose O_1 and R_1 so that the quantity :

$$F = \int_{\text{two arcs}} (\rho_1(\psi) - R_1)^2 d\psi \quad (26)$$

is minimum with respect to the position of O_1 and the value of R_1 . This choice ensures that the vector $\delta = OO_1$ is not correlated with even modes v_q , but with odd modes (because the contour is not entirely known). In the calculation of $\xi(\gamma)$ only even q -modes take part (see expression (13)). So, the form of $\xi(\gamma)$ and the choice of the centre O_1 with respect to which the fluctuations are measured, ensures that all the corrections due to the incompleteness of the contour and the uncertainty in the centre position of the vesicle are negligible (of higher order with respect to kT/k_c).

Let us call D_0 the mean value of the contour diameter observed under the microscope. Due to the optical method and the treatments applied for the determination of the contours (see below), the mean diameter of the vesicle D_0 depends on the angle ψ with respect to the axis X : $D_0 = D_0(\psi)$. This means that when the vesicle does not fluctuate, the arcs representing the contour will be parts of an ellipse or a more complicated figure (this does not mean that when $T = 0$ the cross-section of the vesicle in plane XY is elliptical, but that the contour representing the cross-section is elliptical). Let $D_{\max} = \max |D_0(\psi)|$ and $D_{\min} = \min |D_0(\psi)|$. We denote :

$$\nu = \frac{D_{\max} - D_{\min}}{D_0} \quad (27)$$

In our experiment we have $\nu \approx 0.05$. With a precision of the order of ν , the fluctuation $v(\psi, t) + v(\psi + \pi, t)$ can be obtained as :

$$v(\psi, t) + v(\psi + \pi, t) = D(\psi, t) - D_0(\psi) \quad (28)$$

There is one more factor which could influence the final results, namely, the noise. As can be seen in the next section, the origin of the noise is the discretization of the contour (its representation as an ensemble of a finite number of points) and the electrical noise of the apparatus (camera and video-recorder). Let the contour be represented by n approximately equidistant points. We denote $\psi_{\min} = 2\pi/n$. Our assumption is that if the amplitude of the noise, denoted by $v_{\text{noise}}(\psi, t)$, which depends on the polar angle ψ and on time t , obeys the following relation :

$$\langle v_{\text{noise}}(\psi, t) \times v_{\text{noise}}(\psi + \gamma, t) \rangle = 0 \quad (29)$$

when

$$\gamma > \psi_{\min}.$$

In other words, the contribution of the noise to the function $\xi(\gamma)$ will be a δ -like function at $\gamma = 0$. More precisely, this contribution will have a Gaussian shape with half-width of the order of ψ_{\min} .

The measured amplitudes $\langle |v_q(t)|^2 \rangle$ contain a noise contribution. Making the reasonable assumption of a white noise (this condition is stronger than condition (29)), a constant value will have to be subtracted from $\langle |v_q(t)|^2 \rangle$ for each value of q .

3. Experiment.

In the experiments we have used egg-yolk lecithin prepared in the laboratory. The method applied for the extraction of the phosphatidylcholine was that of Singleton *et al.* [26]. Egg-yolk was precipitated in acetone. The residue was passed through ethanol, in which the lecithine was dissolved. A purification of the product was achieved *via* dissolution in petroleic ether and precipitation in acetone. A second chromatographic purification over a column of aluminium separated the phosphatidylcholine from the fatty acids and other phospholipids. The final product (chromatographically pure) was lyophilized and kept under vacuum.

To obtain giant vesicles we used a procedure described in [21, 22]. 5 mg of the lecithin were dissolved in 0.5 ml of the solvent 2:1 v:v chloroform-methanol. The solution was placed in a 10 ml flask, and the solvent was evaporated under vacuum for about 10 min. During evaporation the flask was inclined at 45° and gently turned. By this method the lecithin deposited on the periphery of the bottom of the flask. The recipient was filled with deionized water which was deaired by nitrogen bubbling. Two samples were prepared and maintained at room temperature, for the lecithin swell. Observations were carried out after three days on the first sample and after 6 days on the second. Probes were taken at different distances from the bottom, without disturb-

ing the solution. Vesicles were selectively searched for which were isolated and which had a membrane free of visible defects under the microscope (we will call them « perfect » vesicles). After 3 days « perfect » vesicles were found with a diameter smaller than $10\ \mu\text{m}$. After 6 days vesicles up to $20\ \mu\text{m}$ were found, but never perfect (they had always one or more little vesicles of the order of $1\ \mu\text{m}$ stuck either in or out of the membrane). These results were confirmed in experiments performed later [27]. After observation, the water was evaporated from the flask in order to concentrate the solution. On the so-concentrated solution, thin-layered chromatography was carried out to verify the decomposition of the phosphatidylcholine molecules. Plastic sheets pre-coated with silica-gel 60 (Merck) were used. The eluant was a chlorophorme : methanol : water solution (65 : 25 : 4 v/v/v). Spots containing $\approx 100\ \mu\text{g}$ of the lecithin were deposited on the sheets. The chromatograms were revealed with iodine and the visualisation techniques of Dittmer. With this amount of lecithin in the initial spot the method permits the detection of quantities of lysolecithin (product of the decomposition of the lecithin) of more than 5%.

The sample from the third day did not reveal the spot corresponding to the lysolecithin. Above the spot of lecithin, a spot of admixture molecule was observed, which was interpreted as traces of fatty acids. The sample from the 6th day revealed a spot of a lysolecithin. The results of the control can be summarized as follows : after the third day the decomposition of lecithin is less than 5%, and after the 6th day above this limit.

The optical observations were carried out under the inverted microscope IM 35 (Carl Zeiss, Oberkochen, BRD) working in the regime of the Nomarski Differential Interference Contrast. The principle of the method is described in detail in [28]. Its main properties are briefly described here. The beam of incident light is split into two spatially separated beams with a distance slightly superior to the resolution of the microscope ($\approx 0.15\ \mu\text{m}$). The contrast of the resulting image increases proportionally to the optical path difference introduced by the specimen in the two separated beams. Let the direction of the incident light beam be that of the axis Z of the XYZ frame in which we observe the vesicle. The plane XY is taken as the object plane of the microscope. Let the plane passing through the two split beams be parallel to the ZY plane. Due to proper polarisations of the beams and their interference, the microscope offers the following possibilities when the objective $\times 100$ is used : the practical resolution of the microscope is smaller than the theoretical limit of $0.2\ \mu\text{m}$; the depth of field is $\approx 2\ \mu\text{m}$. When a gradient of refractive index in the Y direction exists, it is visualized. If the gradient is parallel to the axis

X , the corresponding region is not visualized. In the intermediate cases, the smaller the angle between the gradient and the X axis, the better the contrast.

The method provides the possibility of detecting the cross-section of the vesicle membrane with the object plane, despite its very little thickness. Because of the particularity of the method, the real circular contour will be observed as two arcs (the parts of the contour parallel to the axis X are not visualized). The two arcs represent approximately 80% of the contour.

The cells, used in the optical observation, are illustrated in figure 4.

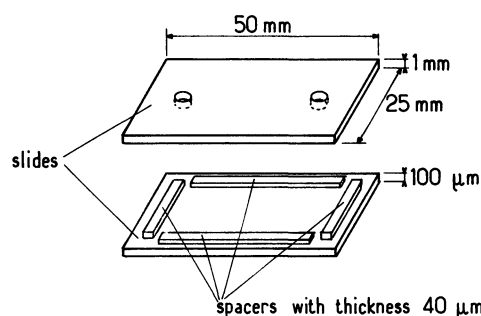

Fig. 4. — Cell used for the optical observation. Material of the slide-glass. Thickness of the slides : upper 1 mm, lower $100\ \mu\text{m}$. The spacers, disposed as shown in the figure, had a thickness $40\ \mu\text{m}$. They were coated with araldite. The same adhesive filled up the empty spaces in the periphery of the cell. The thickness of the cell, after it was stacked up, was $\approx 60\ \mu\text{m}$. The upper slide had two holes, through which the cell was filled with the vesicle suspension. After the filling the holes were sealed in order for the cell to be hermetic, to avoid flows within the cell.

The vesicles revealed a tendency to sedimentate with time. Only « perfect » vesicles were studied, which were far enough from the surfaces of the cell, and which were not in contact with other vesicles. These requirements diminished drastically the ensemble of vesicles used. We made a comparison between images of the same sample, observed under the microscope in the regime of phase contrast and that of Nomarski Differential Interference Contrast. The number of details (little vesicles, threads, tube like vesicles, etc.) revealed by the second method is much larger. We found objects consisting of two or more concentric vesicles. Onion like structures were observed, where the different layers were well distinguishable. The question arises whether the « perfect » vesicles that we found were unilamellar. We believe that the answer is yes. Indeed, let us assume that a multilamellar vesicle is formed. The time of swelling being three days (or 6 days) water penetrates between the layers. If this happens for multilamellar structures (with more than 100 layers)

as we have observed, it must be also the case for liposomes consisting of 2, 3 or more layers, and because the layers in the onionlike structures are well distinguishable when using our optical setup, it is reasonable to accept that the layers would be distinguishable as well in multilamellar liposomes subjected to the same treatment.

The main advantage of the optical method that we used is its greater resolution. This method permits the identification of « perfect » vesicles which are probably unilamellar.

Once a « perfect » vesicle has been detected, it is recorded by a videotaperecorder during 2 minutes. The camera can be a standard video camera or a high sensitivity camera. Using a standard camera, the signal level may be rather low, inducing high camera noise. After recording, the sequence is digitized and analysed on a image analysis system ⁽¹⁾. First a spatial filtering is performed to eliminate noise from the camera and more generally to smooth out high frequency random noise. Next, a horizontal scanning of the picture is performed to detect the vesicle contour, whose intensity profile is given in figure 5.

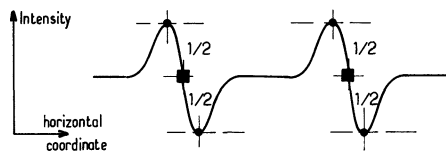

Fig. 5. — Contour detection: extrema (●) are first located, then the contour point (■) is defined at half height position.

This treatment gives a « raw » contour. It is then analyzed to determine the two largest arcs. A distance criterion is defined, typically 5 pixels for a vesicle with a diameter of ≈ 100 pixels, to determine whether two successive contour points belong to the same arc. This procedure is designed to eliminate short noisy pieces of contour near angles $\pi/2$ and $-\pi/2$ where the optical set-up is unable to visualize the contour. This gives two long arcs near 0 and π .

We then determine the centre of the contour according to the procedure described above (see the discussion before and after Eq. (26)). From this centre is defined the effective contour. We keep only those contours which cover both intervals $[-\pi/4, \pi/4]$ (right side) and $[3\pi/4, 5\pi/4]$ (left side). Only the points of the contour belonging to

these intervals were used to calculate the diameter correlation function $\xi(\gamma)$ defined in equation (17).

In figure 6, we show images of the vesicle before and after smoothing, as well as the profile of the intensity of the signal along one horizontal line.

We found four vesicles which seemed to be perfect. About 300 contours, taken on a time interval of the order of 120 s, were analysed for each vesicle. The time between two successive records was ≈ 0.5 s (not exactly constant). After the treatment, smoothing of the image and obtaining the two arcs of the contour, only $\approx 15\%$ of the contours satisfied the condition that their two arcs cover entirely the intervals of polar angles: $[-\pi/4, \pi/4]$ and $[3\pi/4, 5\pi/4]$. These « correct » contours were virtually random samples among the initial ≈ 300 contours. An analysis of fluctuations was made only for those contours with large enough arcs (i.e. about 40-60 contours for each vesicle).

If at all times the centre of the vesicles were located on plane XY , the quantity $D_0(\psi)$ defined in (28) could be represented as $\langle D(\psi, t) \rangle$, where $D(\psi, t)$ is the diameter of the contour making angle ψ with axis X at time t . But because of the Brownian motion the vesicle changes its position, not only in the plane XY , but in the Z direction of the reference frame as well. If the centre O of the liposome is out of the mid-plane of the slab where the objects are visible, the cross-section of the vesicle will not correspond to the equatorial one. As a consequence the mean diameter of the vesicle will diminish. In the process of recording we continuously focused the object, trying to obtain the maximal area of the cross-section observed on the video monitor. Inevitably the centre O fluctuates around the mid-plane (even if we compensate part of this fluctuation). Let us denote by $\varepsilon(t)$ the distance between the centre O and the mid-plane of the slab at time t . We assume that $\varepsilon \ll R$. The mean diameter $\langle D(\psi, \tau) \rangle$ can then be expressed as :

$$\langle D(\psi, t) \rangle = D_0(\psi) \left\{ 1 - A_1 \frac{\langle |\varepsilon(t)|^2 \rangle}{R^2} + O \left(\left[\frac{\langle |\varepsilon(t)|^2 \rangle}{R^2} \right]^2 \right) \right\}. \quad (30)$$

To obtain this quantity we used the fact that, when $\langle |\varepsilon(t)|^2 \rangle = 0$, $\langle D(\psi, t) \rangle$ must be maximal. A_1 is a positive constant of the order of unity, $\langle |\varepsilon(t)|^2 \rangle$ depends on the speed of correction for refocusing the vesicle. The values $v(\psi, t) + v(\psi + \pi, t)$ also depend on $\varepsilon(t)$, but because of the assumption that $\varepsilon(t)/R \ll 1$, we disregard this correction ($\varepsilon(t)$ should give as a result that $\xi(\gamma)$ from (16) must be multiplied by a factor of the kind

$$|1 + \alpha (\langle |\varepsilon(t)|^2 \rangle / R^2)^2|,$$

where $\alpha \approx 1$).

⁽¹⁾ We use U-Matic standard tape recorder. Digitization and image analysis is performed on a Pericolor 2000 system from Numelec Company; digital pictures have 512×512 8 bits pixels.

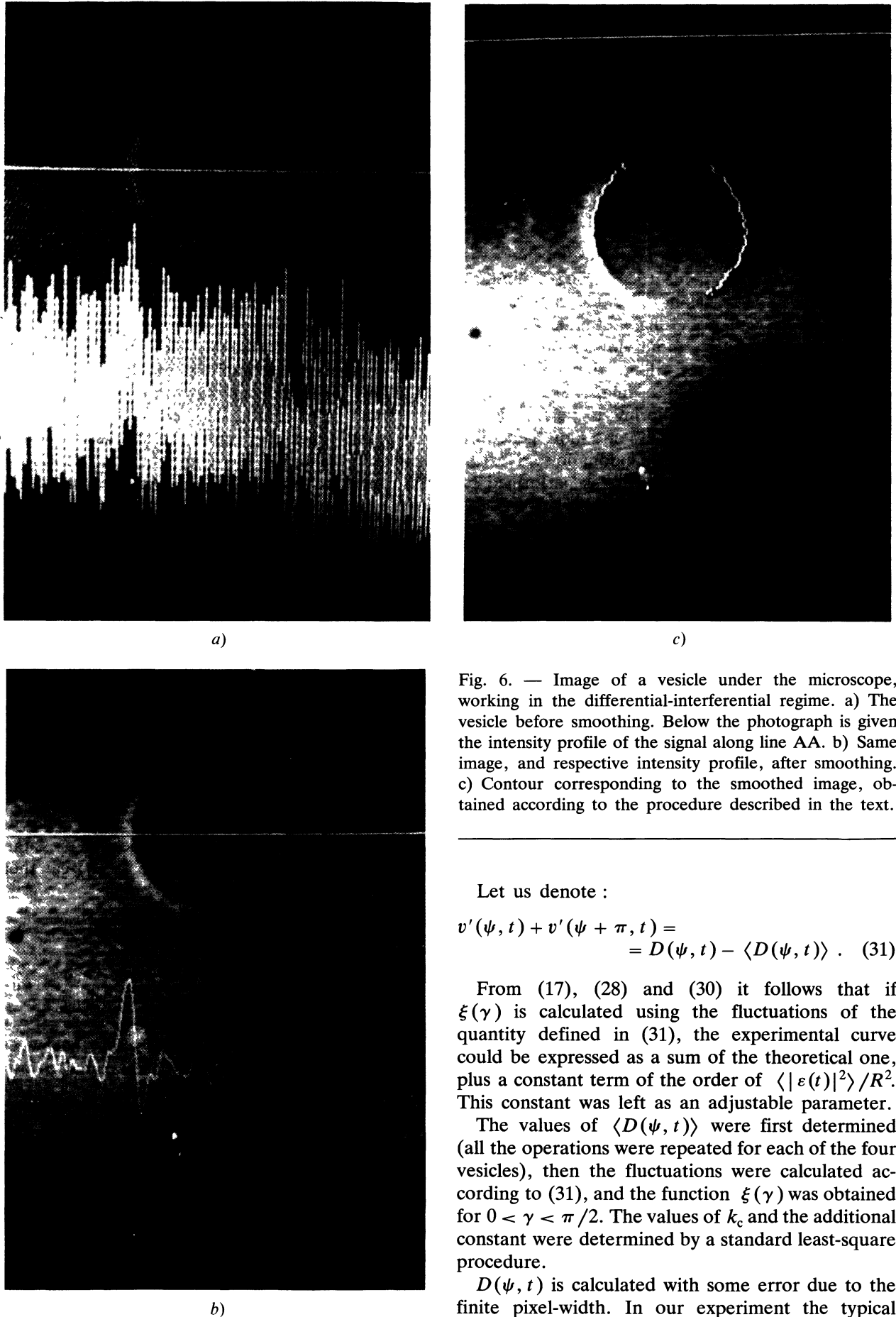

Fig. 6. — Image of a vesicle under the microscope, working in the differential-interferential regime. a) The vesicle before smoothing. Below the photograph is given the intensity profile of the signal along line AA. b) Same image, and respective intensity profile, after smoothing. c) Contour corresponding to the smoothed image, obtained according to the procedure described in the text.

Let us denote :

$$v'(\psi, t) + v'(\psi + \pi, t) = D(\psi, t) - \langle D(\psi, t) \rangle. \quad (31)$$

From (17), (28) and (30) it follows that if $\xi(\gamma)$ is calculated using the fluctuations of the quantity defined in (31), the experimental curve could be expressed as a sum of the theoretical one, plus a constant term of the order of $\langle |\varepsilon(t)|^2 \rangle / R^2$. This constant was left as an adjustable parameter.

The values of $\langle D(\psi, t) \rangle$ were first determined (all the operations were repeated for each of the four vesicles), then the fluctuations were calculated according to (31), and the function $\xi(\gamma)$ was obtained for $0 < \gamma < \pi/2$. The values of k_c and the additional constant were determined by a standard least-square procedure.

$D(\psi, t)$ is calculated with some error due to the finite pixel-width. In our experiment the typical

value of D , measured in pixels was ≈ 100 with an accuracy of the order of 1 pixel. For the quantity $\langle D(\psi, t) \rangle$ the error is of the order of $1/\sqrt{N}$ (in pixels) where N is the number of contours taken into account. With $N \approx 50$, the error in $\langle D(\psi, t) \rangle$ appears to be of the order of 0.15 pixels. Consequently for the difference $D(\psi, t) - \langle D(\psi, t) \rangle$ the error δ_p in a single measurement is of the order of 1.15 pixels. For a given angular displacement γ , the minimal number of contour points $j(\gamma)$ for which $\xi(\gamma)$ is calculated, and for which the errors are not correlated because of the finite pixel width, is :

$$j(\gamma) \approx \frac{\gamma}{\frac{\pi}{2}/100} \quad (32)$$

(the arcs contain approximately 100 pixels). The measured value of $\xi(\gamma)$ is of the order of 10^{-3} (see Fig. 7). Then, the error $\Delta\xi(\gamma)$ in $\xi(\gamma)$ should then be :

$$\Delta\xi(\gamma) = \frac{4[\xi(0)]^{1/2} \delta_p}{\sqrt{j(\gamma)} \sqrt{N} D}. \quad (33)$$

A numerical estimate using the above mentioned values of ξ , N and D is :

$$\frac{\Delta\xi(\gamma)}{\xi(\gamma)} \approx \frac{0.2}{\sqrt{j(\gamma)}}. \quad (34)$$

Because $j(\gamma)$ varies between 1 and 100 $\Delta\xi(\gamma)/\xi(\gamma)$ varies between 20 % for $\gamma \approx \pi/2$ and 2 % for $\gamma \approx 0$.

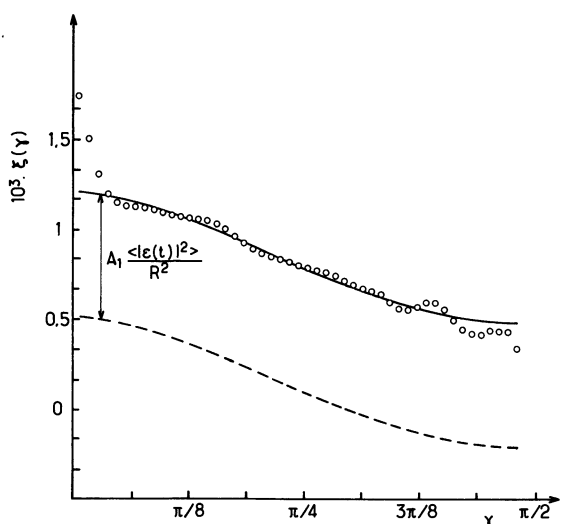

Fig. 7. — Experimental data for $\xi(\gamma)$ (circles), the fitted theoretical curve with parameters k_c and $A_1(\langle |\epsilon(t)|^2 \rangle / R^2)$ (continuous line) and the corresponding theoretical curve when $\langle |\epsilon(t)|^2 \rangle$ should be equal to zero (dotted line). Diameter of the vesicle : 7.1 μm . The deviations around $\gamma = 0$ are the contributions of the noise (for details see the text).

One could wish to evaluate the minimal number N of contours necessary for calculating $\langle D(\psi, t) \rangle$ and $\xi(\gamma)$. We think it is the time interval on which the images are taken which is more crucial. This time interval must be much greater than the characteristic time of relaxation of a given fluctuation (which is of the order of 5 s [21]). The vesicle sustains rotational diffusion motion as well. But this will only decrease the necessary minimal time interval mentioned above. When it is long enough, the error in $\langle D(\psi, t) \rangle$ is of the order of $\xi(0)^{-1/2} D/2\sqrt{N}$ (supposing that there is no error in the measurement of $D(\psi, t)$). The error $\Delta_1\xi(\gamma)$ due to the finite number of contours is :

$$\Delta_1\xi(\gamma) = \frac{o(0)}{\sqrt{N} \cdot j(\gamma)} \left(1 + \frac{1}{\sqrt{N}} \right). \quad (35)$$

This formula allows us to determine the number N of contours necessary to obtain a given precision. In our experiment with $N \approx 50$ and $\xi(0)/\xi(\gamma) \approx 1/2$ for $\gamma > \pi/25$, the relative error is :

$$\frac{\Delta_1\xi(\gamma)}{\xi(\gamma)} \approx \frac{0.3}{\sqrt{j(\gamma)}}. \quad (36)$$

This error is between 30 % for $\gamma \approx \pi/2$ and 3 % for $\gamma \approx 0$. These estimates show that the fit between the theoretical curve and the experimental data is expected to be worse for the larger values of γ , which is indeed the case as shown in figure 7.

A typical curve is given in figure 7. Around $\gamma = 0$ a displacement of the experimental data from the fitted curve can be noted. According to our interpretation, this is the result of the preliminary smoothing of the image, which changes the spectrum of the noise. As a consequence the δ -function (more precisely the Gaussian function with halfwidth $\approx \psi_{\text{min}}$), representing the contribution of the noise, changes in a Gaussian curve with a larger halfwidth. Performing double smoothing gives a still greater increase of the halfwidth of this part of the curve, which confirms our interpretation.

The values of k_c calculated for the four vesicles studied are presented in table II. The values for the 1st, 2nd and 4th vesicle are very similar. The value for the third vesicle deviates by about 30 %. For this

Table II. — Values of k_c , obtained after best fit of the experimental data with the theoretical curve.

Diameter of the vesicle (μm)	9.0	7.1	5.6	4.7
$10^{12} \times k_c$ (erg)	1.28	1.40	0.94	1.48

same vesicle the constant, proportional to $\langle |\varepsilon(t)|^2 \rangle$, is much smaller (but still positive) in comparison with the other three. An explanation could be that this vesicle is not free. It could be attached to the surface of the cell by filaments, which are too thin to be visualized under the microscope.

The fact that for the four liposomes the values of k_c are almost identical is added evidence that, when the vesicle seems to be « perfect » under the microscope (after some days of swelling), it is probably unilamellar.

The average value of k_c for the four vesicles is :

$$k_c = (1.28 \pm 0.25) \cdot 10^{-12} \text{ erg} . \quad (37)$$

4. Discussion.

We would like to begin by discussing the nature of the modulus k_c , as measured by this experimental method, and by other similar experiments. It is well known that two curvature elastic moduli exist [11] at free flip-flop, k_c^{fr} , and at blocked flip-flop, k_c^{bl} . When the flip-flop is free, the chemical potential of the molecules from the two sides of the bilayer are equal because the exchange of molecules between the monolayers is permitted. In the other case the equality of the chemical potential is no longer valid. According to theoretical estimate [11], k_c^{fr} is one order of magnitude less than k_c^{bl} . The characteristic time of the flip-flop is very long (of the order of days) for the pure lecithin. But there is one more mechanism for the redistribution of molecules within the bilayer, namely, the lateral displacement (Fig. 8). Let us consider the vesicle at $T = 0$. After a sufficient time it will attain its equilibrium state in which the number n^o of the molecules per unit area of the membrane in the « outer » monolayer is

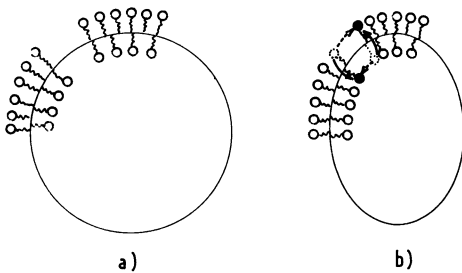

Fig. 8. — Schematic distribution of the molecules in the two monolayers of the vesicle. a) Without fluctuation. b) With fluctuation. Two mechanisms can contribute to the relaxation towards equilibrium, after the creation of the deformation: the molecules can pass from the one monolayer to the other by free flip-flop (solid arrow), or they can be redistributed by lateral displacement without going out of their monolayer (dashed arrow). The latter is a much faster process.

slightly greater than this number n^i in the « inner » monolayer. A coefficient of flip-flop l^f can be defined [10] :

$$l^f = \frac{n^o - n^i}{n^o + n^i} \cdot \frac{R}{2}$$

i.e.

$$n^o = (n^o + n^i)(1 + 2/Rl^f)$$

$$n^i = (n^o + n^i)(1 - 2/Rl^f)$$

$$n^i + n^o = n^{\text{tot}} = \text{Const.} \quad (38)$$

Let a slightly deformed state, characterized by the function $u(\theta, \psi)$, occur (see Eq. (2)). If the flip-flop is free, the total number of molecules in the inner (N^i) and outer (N^o) monolayers will be :

$$\begin{aligned} N^o &= l^f \int_{\text{surface of the vesicle}} [1 + c(\theta, \psi)] n^{\text{tot}} ds \\ &\approx l^f R^2 \int [1 + c(\theta, \psi)] n^{\text{tot}} \sin \theta d\theta d\psi \\ &\approx l^f R^2 n^{\text{tot}} \left(1 + \frac{1}{R}\right) 4\pi \end{aligned} \quad (39)$$

$$\begin{aligned} N^i &= l^f \int_{\text{surface of the vesicle}} [1 - c(\theta, \psi)] n^{\text{tot}} ds \\ &\approx l^f R^2 \int [1 - c(\theta, \psi)] n^{\text{tot}} \sin \theta d\theta d\psi \\ &\approx l^f R^2 n^{\text{tot}} \left(1 - \frac{1}{R}\right) 4\pi \end{aligned}$$

with $c(\theta, \psi)$ from (4). Within the scope of these approximations N^o and N^i do not depend on the form of $u(\theta, \psi)$. When a fluctuation $u(\theta, \psi, t)$ appears, changes in the equilibrium local densities of both monolayers appear as well. Consequently if the densities are kept, as in the case without fluctuation, the so obtained state can be considered as a state with density fluctuations in both monolayers. An energy of stretching of both monolayers is accumulated and the vesicle will tend to relax to the state, when this energy is zero. This can be done *via* the exchange of molecules between the monolayers (flip-flop, very slow process). But our considerations show that the same equilibrium state can be attained *via* a translational displacement of the molecules in the same monolayer (a process which is much more rapid). The estimation of the relaxation time τ will be carried out. For simplicity, again the situation with a flat membrane with periodic boundary conditions will be considered. τ can be expressed *via* the stretching elasticity modulus k_s , the effective surface viscosity α , and the length « p » of the wave vector :

$$\tau = \frac{\alpha}{k_s p^2} . \quad (40)$$

τ will be longer for the mode with minimal p ;
 $p_{\min} = 2 \pi / \sqrt{s}$:

$$\tau_{\min} = \frac{\alpha s}{k_s 4 \pi^2} . \quad (41)$$

The main contribution in α is due to the friction between the two monolayers (relaxing, the corresponding points of the two monolayers have opposite velocities). We assume that this friction can be taken into account by means of one effective viscosity α' :

$$\alpha' = \frac{\alpha_0}{\Omega} \quad (42)$$

where α_0 is the viscosity of the hydrocarbon chains (similar to the viscosity of the hydrocarbons) and Ω is the thickness of the layer where the hydrophobic chains of both monolayers interpenetrate. With $\alpha \approx 1 p$, $\eta \approx \eta_0$, $\Omega \approx 10 \text{ \AA}$, $k_s \approx 100 \text{ dyn/cm}$, $s \approx 2 \times 10^{-6} \text{ cm}^2$:

$$\tau_{\min} \approx 1 \text{ ms} . \quad (43)$$

This value of τ_{\min} is much less than the time of observation of the vesicle in our experiment, so that really the curvature elasticity modulus of free flip-flop is measured.

The exact effective curvature elastic modulus k_c^{eff} can be expressed as :

$$k_c^{\text{eff}} = k_c^{\text{fr}} \left(1 + \frac{k_c^{\text{bl}}}{k_c^{\text{fr}}} \text{O} \left(\frac{kT}{k_c^{\text{fr}}} \right) \right) . \quad (44)$$

Actually, with $k_c^{\text{fr}} \approx 10^{-12} \text{ erg}$, the approximation $k_c^{\text{eff}} \approx k_c^{\text{fr}}$ is good enough, if $k_c^{\text{fr}} \geq 0.1 k_c^{\text{bl}}$.

Finally we would like to discuss the influence of small vesicles attached to the membranes of larger vesicles (we normally discard these vesicles as non perfect). The modulus measured in that case, is one order of magnitude smaller. The reason for this is that the little defect changes locally the curvature of the membrane of the giant vesicle. Its mean form (when $T = 0$) should no longer be spherical but egg-like (with the little vesicle at one of the poles). Because of the rotation of this « egg », great fluctuations in the form of the cross-section appear, which are interpreted as thermal fluctuations, corresponding to a very low value of k_c .

Acknowledgments.

We would like to express our gratitude to our colleagues who helped us in various ways during the course of this work, by enlightening discussions, manuscript typing and checking, and technical support, in particular MM. Faucon, Desmazes, Schumaker, Dufourc and Moineau, and Ms. Abarretegui and Guineau.

References

- [1] BOTHOREL, P., LUSSAN, C., *C. R. Heb. Séan. Acad. Sci.* **266** (1968) 2492.
- [2] LUSSAN, C., BOTHOREL, P., *C. R. Heb. Séan. Acad. Sci.* **268** (1969) 1118.
- [3] BOTHOREL, P., LUSSAN, C., *C. R. Heb. Séan. Acad. Sci.* **271** (1970) 680.
- [4] AMBROSE, E. J., OSBORN, J. M., STUART, P. P., in *Liquid Crystals and Ordered Fluids*, Eds. J. F. Johnson and R. S. Porter (Plenum Press, N.Y.) 1970, p. 83.
- [5] FERGASON, J. F., BROWN, G. H., *J. Am. Oil Chem. Soc.* **45** (1968), 120.
- [6] SINGER, S. J., NICOLSON, G. L., *Science*, **175** (1972), 720.
- [7] SACKMANN, E., *Ber. Bunsenges. Phys. Chem.*, **82** (1978), 891.
- [8] CHAPMAN, D., WALLACH, D. F. H., in *Biological Membranes*, D. Chapman Ed. (Academic Press, London and New York) 1968, p. 125.
- [9] PETROV, A. G., BIVAS, I., *Progr. in Surface Sci.* **16**, n° 4 (1984), 389.
- [10] HELFRICH, W., *Z. Naturforsch.* **28c** (1973), 693.
- [11] HELFRICH, W., *Z. Naturforsch.* **29c** (1974), 510.
- [12] Groupe d'Etudes des Cristaux Liquides, *J. Chem. Phys.*, **51** (1969), 816.
- [13] BROWICZ, F., *Zbl. Med. Wiss.*, **28** (1890), 625.
- [14] BROCHARD, F., LENNON, J. F., *J. Physique* **36** (1975) 1035.
- [15] FRICKE, K., SACKMANN, E., *Biochim. Biophys. Acta* **803** (1984), 145.
- [16] EVANS, E. A., *Biophys. J.* **43** (1983), 27.
- [17] SERVUSS, R. M., HARBICH, W., HELFRICH, W., *Biochim. Biophys. Acta* **436** (1976), 900.
- [18] BEBLIK, G., SERVUSS, R. M., HELFRICH, W., *J. Physique* **46** (1985), 1773.
- [19] SAKURAI, I., KAWAMURA, Y., *Biochim. Biophys. Acta* **735** (1983), 189.
- [20] SCHNEIDER, M. B., JENKINS, J. T., WEBB, W. W., *Biophys. J.* **45** (1984), 891.
- [21] SCHNEIDER, M. B., JENKINS, J. T., WEBB, W. W., *J. Physique* **45** (1985) 1457.
- [22] ENGELHARD, H., DUWE, H. P., SACKMANN, E., *J. Physique Lett.* **46** (1985) L-395.
- [23] DEULING, H. J., HELFRICH, W., *J. Physique* **37** (1976) 1335.
- [24] JENKINS, J. T., *J. Math. Biol.* **4** (1977), 149.
- [25] JENKINS, J. T., *SIAM J. Appl. Math.* **32**, n° 4 (1977), 755.
- [26] SINGLETON, W. S., GRAY, M. S., BLOWN, M. L., WHITE, J. L., *J.A. Oil Chem. Soc.* **42** (1965), 53.
- [27] LANG, W., Collection of four articles from Zeiss Information, Carl Zeiss, D-7082 Oberkochen, RFG.
- [28] DERZKO, Z., JACOBSON, K., *Biochem.* **19** (1980) 6050.