



HAL
open science

Laboratory performance assessment of low-cost water level sensor for field monitoring in the tropics

Ning Ding, Qingchuan Zhu, Frederic Cherqui, Nicolas Walcker, Jean-Luc Bertrand-Krajewski, Perrine Hamel

► **To cite this version:**

Ning Ding, Qingchuan Zhu, Frederic Cherqui, Nicolas Walcker, Jean-Luc Bertrand-Krajewski, et al.. Laboratory performance assessment of low-cost water level sensor for field monitoring in the tropics. Water Research X, 2025, 27, pp.100298. 10.1016/j.wroa.2024.100298 . hal-04860041

HAL Id: hal-04860041

<https://hal.science/hal-04860041v1>

Submitted on 31 Dec 2024

HAL is a multi-disciplinary open access archive for the deposit and dissemination of scientific research documents, whether they are published or not. The documents may come from teaching and research institutions in France or abroad, or from public or private research centers.

L'archive ouverte pluridisciplinaire **HAL**, est destinée au dépôt et à la diffusion de documents scientifiques de niveau recherche, publiés ou non, émanant des établissements d'enseignement et de recherche français ou étrangers, des laboratoires publics ou privés.



Distributed under a Creative Commons Attribution - NonCommercial 4.0 International License

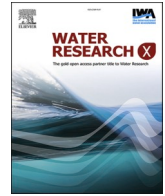

Laboratory performance assessment of low-cost water level sensor for field monitoring in the tropics

Ning Ding^{a,*}, Qingchuan Zhu^b, Frederic Cherqui^{b,c}, Nicolas Walcker^b, Jean-Luc Bertrand-Krajewski^b, Perrine Hamel^a

^a Asian School of the Environment and Earth Observatory of Singapore, Nanyang Technological University, Singapore

^b INSA Lyon, DEEP EA 7429, F-69621, Villeurbanne cedex, France

^c WERG, SAFES, The University of Melbourne, Burnley, VIC 3121, Australia

ARTICLE INFO

Keywords:

Low-cost sensor
Measurement performance
Monitoring
Pressure transducer
Water level

ABSTRACT

As Water Sensitive Urban Design (WSUD) is a key strategy in integrated urban water management worldwide, there is a need for robust monitoring of WSUD systems. Being economical and flexible for operation and communication, low-cost sensor systems show great potential to mainstream digital water management. Yet, such systems are insufficiently tested, casting doubt on the reliability of their measurements. Here, we document a robust testing approach for a pressure transducer water level low-cost sensor (KIT0139) and a traditional sensor (OTT PLS) in both laboratory and field conditions. We tested six different devices under three temperatures relevant to tropical climate: 25, 30, 35 °C and proposed a field calibration approach. Results reveal that the low-cost sensors were robust as the six individual devices performed consistently under different testing conditions. After calibration, low-cost sensors provided sufficient accuracy (± 10 mm) and precision for water levels more than 0.05m. While varying water flow direction did not significantly influence the performance, we showed that calibration should be done for individual devices. In addition, large (>5 °C) variations in water temperature and varying wet/dry conditions may also influence the performance of the low-cost sensors. The field calibration approach was validated in a 3-month experiment, confirming that this model of low-cost sensor can effectively replace traditional sensors in the field in tropical climates. Our study confirms that systematic and thorough testing is needed for low-cost sensors systems to realize their full potential for scientific-grade applications. We provide practical recommendations to conduct such testing from the laboratory to the field.

1. Introduction

Urban hydrological processes have been considerably altered by rapid urbanization, which has resulted in the increase of water-related problems including floods and water pollution (Reu Junqueira et al., 2021). Flood risk has significantly increased in urban areas due to the combination of intensifying stormwater events brought on by climate change (Chang et al., 2021; Rangari et al., 2021), highlighting the significance of Sustainable Urban Water Management principles in urban planning (Kuller et al., 2017). As a complementary approach to traditional engineered and centralized drainage systems, Water Sensitive Urban Design (WSUD) relies on natural and semi-natural systems that are able to retain and purify runoff water (Gleason and Casiano Flores, 2021). WSUD integrates water cycle management with the built environment by retaining, filtering, storing, and utilizing runoff water

resources in the urban area (Gleason and Casiano Flores, 2021). In addition to or in place of the conventional infrastructure, WSUD offers multi-functional landscapes (e.g., wetlands, bioretention basins, rain gardens, cleaning biotopes, green roofs) with numerous benefits (e.g., flood control, water purification, heat mitigation, carbon sequestration), making it the essential long-term strategy in integrated and sustainable urban water management (Keesstra et al., 2018; Tzoulas et al., 2007).

To further understand the role of WSUD in sustainable urban water management, the effectiveness of WSUD has been extensively studied at watershed and sub-watershed scales (Bellezoni et al., 2021; Gunnell et al., 2019; Yau et al., 2017). However, such studies often ignore the field performance of WSUD at the site scale, lacking sufficient empirical data from field monitoring for the model calibration and validation (Hamel and Tan, 2021; Yin et al., 2021). The absence of field monitoring of WSUD is mainly due to the constrained budgets, especially in the

* Corresponding author.

E-mail address: DING0141@e.ntu.edu.sg (N. Ding).

<https://doi.org/10.1016/j.wroa.2024.100298>

Received 26 August 2024; Received in revised form 12 December 2024; Accepted 23 December 2024

Available online 26 December 2024

2589-9147/© 2024 The Author(s). Published by Elsevier Ltd. This is an open access article under the CC BY-NC license (<http://creativecommons.org/licenses/by-nc/4.0/>).

developing areas such as Global South and most countries in Southeast Asia (Hamel and Tan, 2021). Since traditional monitoring systems can be costly and time-consuming, relatively few attempts were made for monitoring the medium to long-term performance of WSUD systems in the Tropics (Bertrand-Krajewski et al., 2021; Hamel and Tan, 2021). The limited monitoring efforts restrict the ability of public agencies and private developers to provide adequate maintenance for existing WSUD systems and to optimize the design of new systems (Kuller et al., 2019).

Compared to traditional monitoring equipment, a low-cost sensor (LCS) presents great economic advantages by providing useful data at a considerably lower expense (Hamel et al., 2024). In addition, low-cost sensors often work on open-source platforms (e.g., Arduino), hence they are more flexible in operation and communication (Cherqui et al., 2020; Mao et al., 2020). LCS technology has been emerging in many fields and shows reliable results (Mao et al., 2019), including for air quality assessment (Ali et al., 2016; Levy Zamora et al., 2019; Morawska et al., 2018), air temperature measurement (Sun et al., 2019), water quality monitoring (Alam et al., 2021; Shi et al., 2021), and agriculture (Valente et al., 2020). Yet, there is insufficient evidence of the performance of off-the-shelf LCS for hydrology, including for water level – an essential parameter for monitoring the performance of WSUD systems. Zhu et al., (2023) reviewed commercially available LCSs for monitoring stormwater and related meteorological variables, including five commercial low-cost water level sensors, and concluded that their performance and associated uncertainties require further testing and evaluation for better quantification.

There are two main types of water level sensors: contact and non-contact sensors, including pressure transducer, ultrasonic sensor, radar sensor, laser sensor, capacitive devices, etc (Loizou and Koutroulis, 2016; Segovia-Cardozo et al., 2021; Tabada et al., 2020). All types of sensors offer distinct advantages and disadvantages in field applications. Contact sensors, such as pressure transducers, are not affected by meteorological conditions like rainfall and wind, and environmental conditions including human and animal activities. However, they are prone to interference from sediment accumulation inside the water since they are typically submerged. On the other hand, non-contact sensors, including ultrasonic, radar, and laser sensors, can be conveniently installed above the water without entering the waterway. Nonetheless, they are more susceptible to environmental disturbances, such as air temperature, wind, rainfall, and obstacles between the sensor and the water. These obstacles may include presence of vegetation, wildlife activity, birds, insects, spiders, or even human vandalism (Catsamas et al., 2023; Intharasombat and Khoenkaw, 2015; Zhang et al., 2019), which can reduce the performance of the sensor in practice. Uneven concrete walls in stormwater manholes and debris in drains can also reduce the performance of ultrasonic and radar sensors due to their wide detection angles (Shi et al., 2021). Thus, submersible pressure transducers are often considered more reliable options for field applications in natural environments with unpredictable human and animal activity (Zhu et al., 2023).

Cherqui et al., (2020) tested and assessed the performance of three types of low-cost water level sensors in the lab platform, confirming the reliability of the pressure transducer. However, the influence of temperature was not systematically evaluated, particularly for low-cost sensors that, in theory, integrate temperature compensation. This may be problematic in the Tropics where higher temperatures are reached in the environment. Although some low-cost sensors already incorporate built-in temperature compensation technology, it remains unclear whether this technology performs as effectively as that in traditional sensors, especially in the Tropics. This gap is common in the literature with the majority of studies ignoring field temperature conditions (e.g., Andang et al., 2019; Dswilan et al., 2021; Gonzaga et al., 2020; Kalyanapu et al., 2023; Kombo et al., 2021; Koshoeva et al., 2021; Nasution et al., 2018; Patil et al., 2020; Shrenika et al., 2017; Zhang et al., 2019). While these studies have tested ultrasonic, laser and pressure water level sensors, none have thoroughly examined the potential impact of

temperature on sensor performance. In addition, studies commonly evaluate one device (e.g., Andang et al., 2019; Espinoza Ortiz et al., 2023; Intharasombat and Khoenkaw, 2015; Nasution et al., 2018; Parra et al., 2017; Paul et al., 2020; Segovia-Cardozo et al., 2021), assuming it is representative of a model or manufacturer's quality. However, lower quality control standards in the low-cost sensor industry may lead to different levels of performance from different devices (Hamel et al., 2024). Therefore, at least three duplicates for the LCS should be tested simultaneously to further confirm the reliability of the LCS.

In this study, we document a testing approach for the off-the-shelf LCS used for affordable and flexible monitoring of WSUD systems, demonstrating that the tested LCS devices can be used for scientific-grade measurements after calibration and under limited temperature variations. The specific objectives are to: 1) Compare LCSs with a traditional sensor (TS) in the laboratory using a range of performance metrics; 2) Assess the change in performance of the sensors in laboratory conditions controlled for water flow direction in the column (up or down) and temperature (tested for tropical temperatures ranging from 25 °C to 35 °C); 3) Propose a field calibration approach for the LCS and evaluate its performance in tropical field conditions.

We selected the OTT PLS model, a commonly used traditional water level sensor. The model of low-cost water level sensor, KIT0139, was chosen for the following reasons: first, it is an off-the-shelf sensor, making it more accessible than sensors still under development in the laboratory, and it can be readily purchased from various local distributors. Second, like the TS, it features a stainless-steel protective casing, which shields the pressure transducer and offers protection for harsh environments. The pressure sensor MS5803–01BA, by contrast, experienced a drift issue in water due to moisture absorption by its white protective layer, requiring re-calibration every two weeks to maintain an accuracy of $\pm 10\text{mm}$ (Shi et al., 2021). Additionally, to prevent corrosion that could compromise the performance of electronic components, using a stainless-steel base instead of iron has been recommended (Pearce et al., 2024). Therefore, KIT0139, with its waterproof stainless-steel housing, is worth testing. Third, it includes a vented tube to compensate for atmospheric pressure, a feature absent in other off-the-shelf pressure sensors like the MS5803 model, commonly used in previous studies (Chan et al., 2021; Cherqui et al., 2020; Kombo et al., 2021; Shi et al., 2021). Using a vented tube could eliminate the need for an additional sensor exposed to the air for measuring atmospheric pressure, which in natural environments could be impacted by wildlife, insects, spiders, or even human vandalism as aforementioned. Also, a vented tube enables immediate, accurate water depth readings in the field without post-deployment processing or applying proximate pressure corrections (Pearce et al., 2024). Finally, this low-cost sensor, similar to the TL231 model mentioned in (Zhu et al., 2023), has not yet been extensively investigated in scientific papers and requires testing to provide valuable insights for broader user applications. Both traditional and low-cost sensors are pressure transducers (Table S-1), which measure the water depth by converting the pressures at different depths of liquid into corresponding current or digital signals. However, the traditional sensor (~1000 USD) is approximately 20 times more expensive than the low-cost sensor (~50 USD). Detailed specifications can be found in the Supplementary Material (Table S-1).

Our study comprises two parts. The main component is a laboratory experiment where we tested six LCS devices in columns filled then emptied with water, at temperatures 25 °C, 30 °C, and 35 °C (Fig. 5). We computed the measurement errors for each sensor with reference to the water level measured with a graduated ruler (1mm mark) and conducted calibration and validation using an ordinary least squares (OLS) method. To identify whether there is a universal calibration line for the LCS, statistical analyses including F test and T test were done to compare the calibration lines generated from each individual LCS under each water flow direction and each water temperature. In addition to computing the laboratory performance metrics for both types of sensors, we also present the performance of the LCS several months later both in the

laboratory and in the field.

2. Results

2.1. Sensor calibration and validation

All unitless digital readings from the six LCS exhibited a strong linear correlation with the reference water level, with R^2 values approaching 1. Calibration lines generated for six LCS (KIT1-KIT6) are shown in Fig. S-10. The results of the statistical analyses indicated that no two calibration lines can be regarded as identical, i.e. that in theory, a given sensor should be calibrated individually, and for a given flow direction or temperature range. To further evaluate whether using different calibration lines — generated via the OLS method for individual LCS devices or for different temperatures — would significantly affect the accuracy of the LCS, errors introduced by applying calibration lines from other temperatures and sensors were compared to those from the original calibration line. The errors generated by using calibration lines under different water temperatures did increase the error range compared to using the original calibration line (Figs. 1, S-5 and S-6), but remained within an acceptable range (MAE less than 50mm) compared to the errors introduced by using calibration lines from different LCS, which were consistently high (MAE more than 100mm). Thus, our results suggest that the calibration should be done for each individual sensor, with sensitivity to temperature further investigated in Section 2.4.

Three-point calibration was assessed to simplify the calibration process of the LCS and to provide guidance for the future field sensor calibration. For two devices, twenty combinations of three points from the reference water levels (0.1m, 0.2m, 0.3m, 0.4m, 0.5m, 0.6m) were used to generate the three-point calibration lines (Figs. 2 and S-18). The errors of the validated measurements by the LCS compared to the

reference water levels are shown in Figs. 2 and S-18, indicating a similar error range with the whole range calibration (0~1.7m). This confirms the feasibility of conducting three-point calibration of the LCS in a field implementation.

2.2. Sensor accuracy assessment

Post-calibration, errors for each of the six LCS were within the range of [-15, 15]mm (Fig. 3). The largest errors generally occurred for water levels of [0, 0.1] m. After additional measurements were conducted within that range, we found that below 0.05m, errors exhibited a random pattern, and were generally higher than for other water levels, indicating that the LCS is more reliable above 0.05m water level. Overall, the mean errors of the six LCS were within [-10, 10]mm, and the mean errors of the TS were less than 0.5mm over the measuring range (Fig. 4). According to the accuracy indicators MAE and RMSE shown in Table 1, the MAE and RMSE values of the six LCS seemed consistent under different water flow direction (Water Up and Water Down) and varying water temperature from 25 °C to 35 °C, indicating that the water flow direction and water temperature do not have a significant impact on the accuracy of the calibrated LCS measurements. A similar conclusion was reached for the TS as well. Compared to the accuracy given by the manufacturer (Table 1), which indicated a theoretical MAE of 4.4mm for the LCS and 0.44mm for the TS over our testing range of 0~1.7m, the LCS exceeded this value on three occasions, and the TS slightly exceeded it on one occasion, confirming the overall reliability of the tested sensors.

2.3. Sensor precision assessment

Numerical values of precision indicators (SD and CV) calculated for

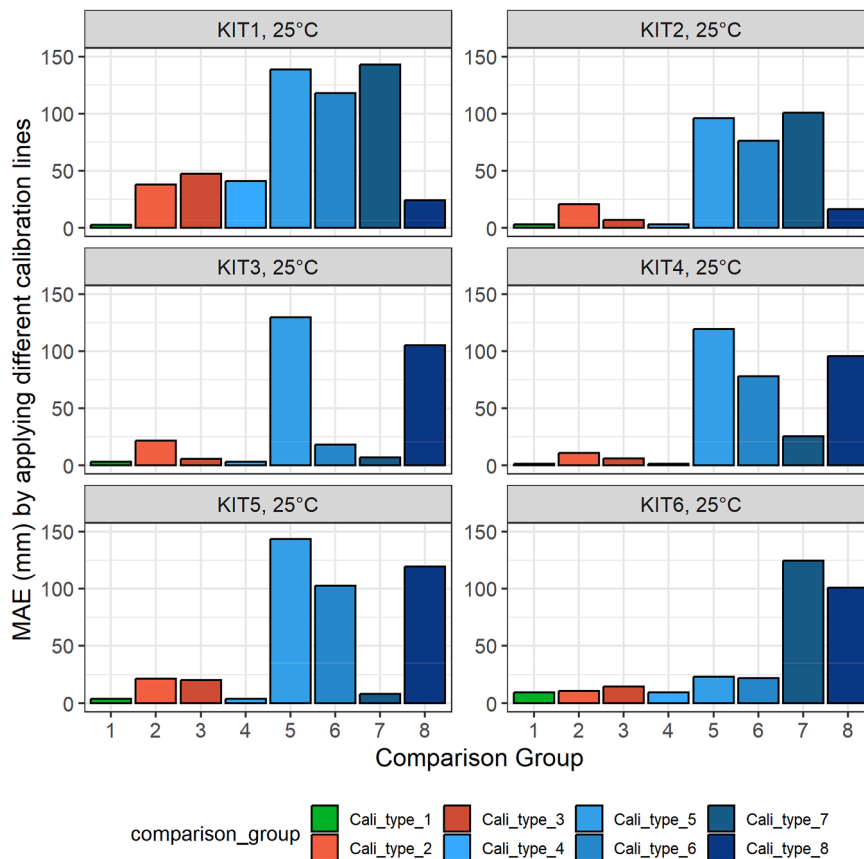

Fig. 1. MAE (mm) after calibration (Cali_type_1, in green) when applying calibration lines from different individual low-cost sensor at 25 °C (KIT1/KIT2/KIT3/KIT4/KIT5/KIT6) (Cali_type_4 - Cali_type_8, shown in blue in the figure) and different water temperatures (30 °C/35 °C) (Cali-type_2/Cali_type_3, shown in red).

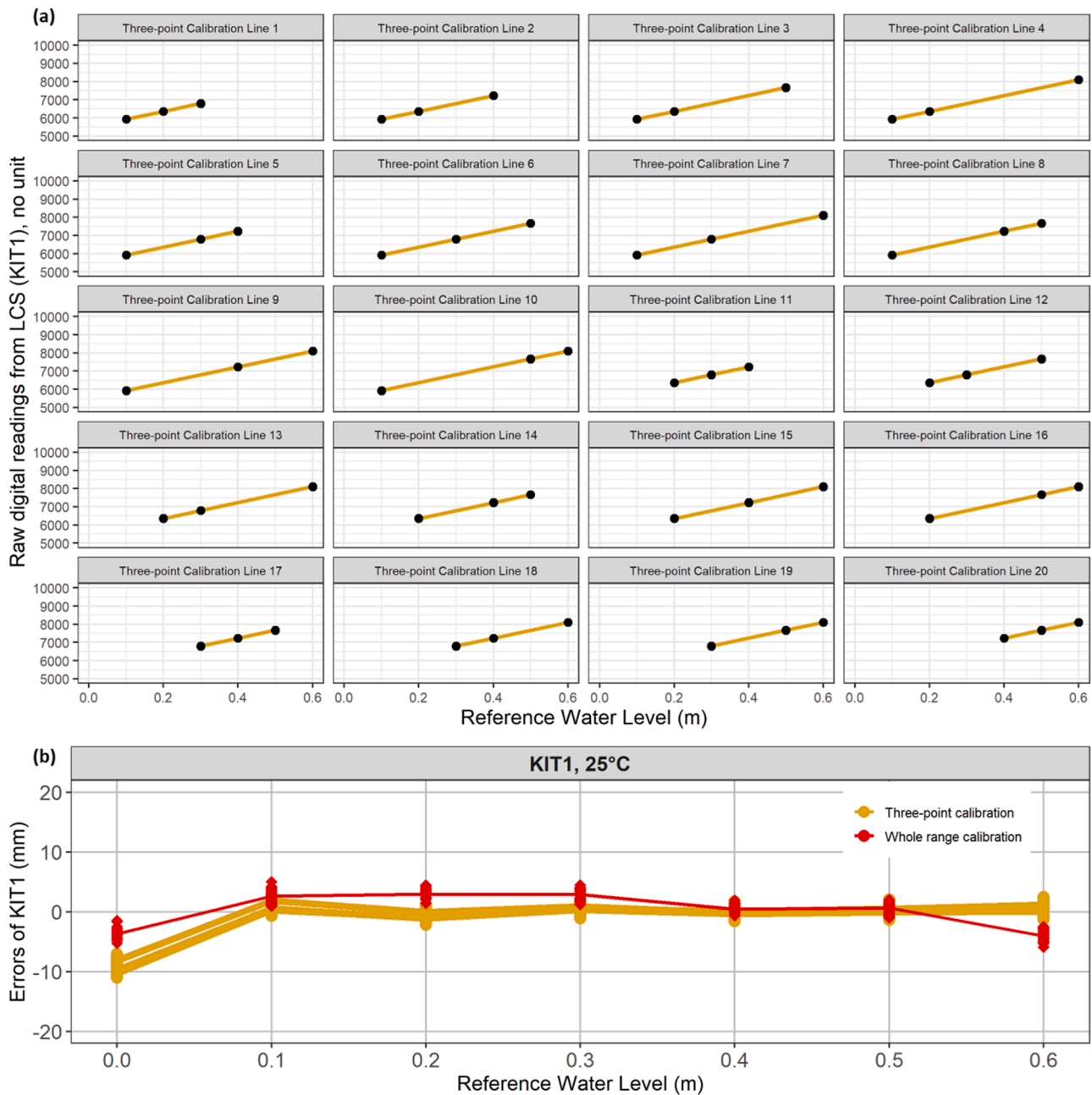

Fig. 2. Twenty three-point calibration lines and the associated errors of the validated measurements for LCS KIT1, compared to the error range of the whole-range calibration at 25 °C. Panel (a) displays the 20 three-point calibration lines for KIT1, while panel (b) illustrates the error range when applying these calibration lines, compared to the error range using the whole-range calibration.

the validated measurements from the sensors are shown in Table 2. Overall, the SD values and CV values for the six LCS and TS were small, indicating that the precision of both LCS and TS are good. Also, the SD and CV values of each sensor showed very little variation under the different testing conditions (varying water flow direction and water temperature), which confirmed that different testing conditions do not significantly influence the precision of LCS and TS tested. To further observe the variability of the LCS over the measuring range, the error between each measurement from the LCS with the reference value at each water level was compared and shown in the boxplot (Fig. S-3). The variability of measures by the LCS showed most of the measurements at each reference water level varied within 5mm at two water flow directions and three water temperature degrees. No trend of variability changing either for the different water flow directions or the water temperatures was found for the six LCS. For different individual LCS, the

boxplot showed that the low-cost sensors tested in group A (KIT1, KIT2, KIT3) have larger variabilities than the sensors tested in group B (KIT4, KIT5, KIT6), indicating a potential influence of varying dry and wet conditions on the LCS's variability. This observation is further supported by the standard deviation (SD) and coefficient of variation (CV) values for the two groups of LCS. The SD values for the LCS in Group B (KIT4, KIT5, KIT6) were generally lower than those in Group A (KIT1, KIT2, KIT3). A similar trend was observed for the CV values, with Group B exhibiting lower CV values compared to Group A.

2.4. Sensitivity to water temperature

Overall, based on the variations in accuracy (MAE and RMSE) and precision (SD and CV) under different water temperature conditions, water temperature did not show a significant impact on the performance

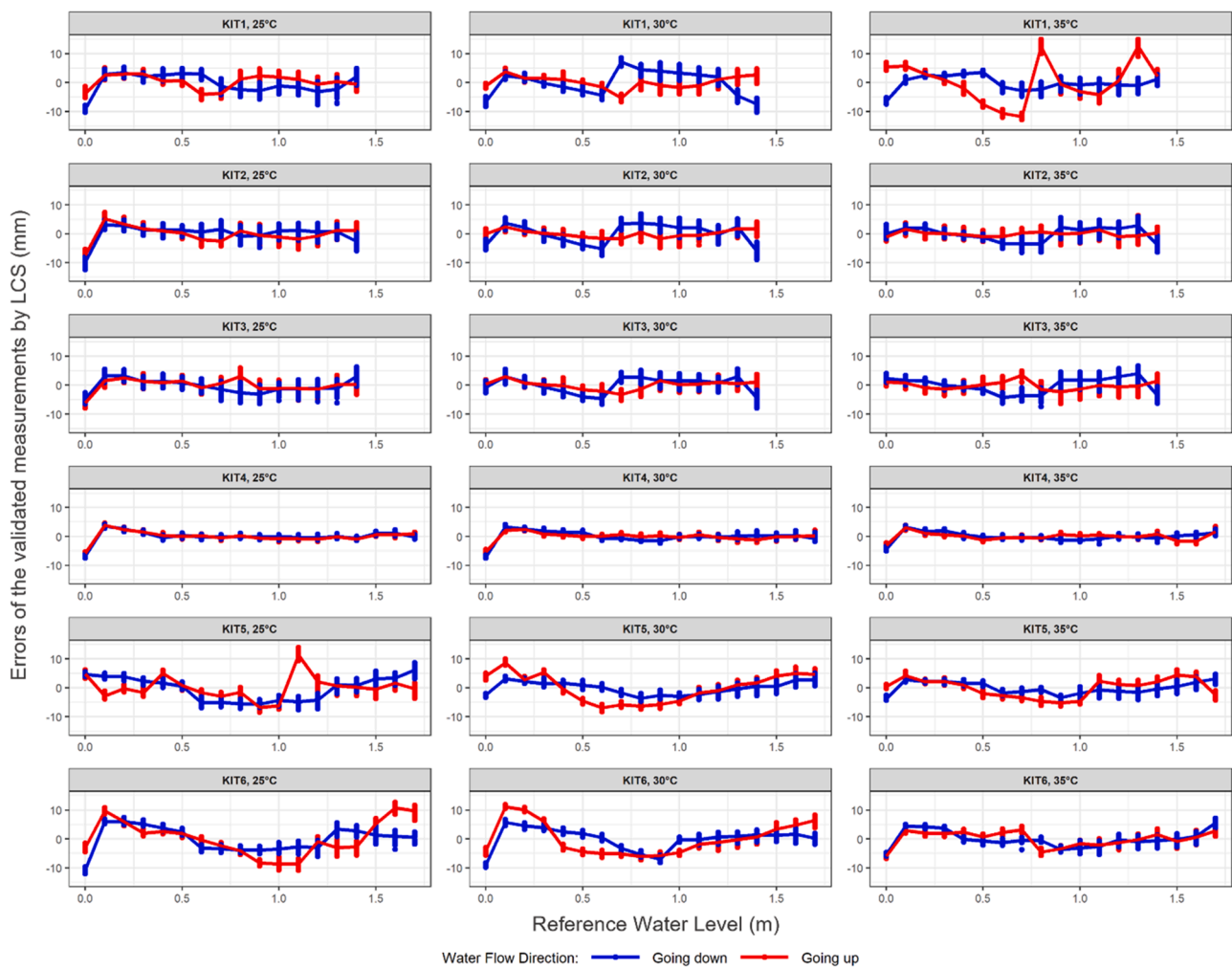

Fig. 3. Errors introduced by the validated measurements of LCS (KIT1-KIT6) at three water temperatures over the measuring range. Red points represent the errors of measurements at the water going up flow direction, while blue points represent the errors of measurements at the water going down flow direction.

of the six LCS devices after calibration. For instance, the MAE variation remained below 0.073mm for a temperature range of 25–30 °C, below 0.35mm for a range of 25–35 °C, and below 0.76mm for a range of 30–35 °C. To further explore whether there is an influence of water temperature on the sensor calibration, a comparison of the calibration lines (focusing on the values of slopes and intercepts) under different water temperature degrees was conducted. The results indicated a minimal influence of water temperature on the calibration lines of the sensors, and there was no trend among the six sensors found between the slope and intercept values of the calibration lines under varying water temperatures of 25 °C to 35 °C (Fig. S-7).

Fig. 1 shows the MAE (mm) resulting from the application of different calibration lines to individual low-cost sensors at 25 °C. The results showed that using calibration lines derived from different temperatures (30 °C or 35 °C) increased the MAE range up to approximately 50mm for one of the six devices (KIT1), and up to about 25mm for the other five devices (KIT2, KIT3, KIT4, KIT5, KIT6). Figs. S-5 and S-6 show similar results for other temperatures. While these errors are greater than those obtained for a constant temperature (Table 1), they remain acceptable for small temperature variations in the field. For example, the temperature data collected during the three-month field experiment (Fig. S-17) shows that temperatures mostly remained within a 3 °C range. Therefore, the measurement errors in the field, under varying temperature conditions, are expected to be lower.

2.5. Long-term reliability, stability of the low-cost sensor

The three-point calibration experiment was conducted eight months after the main experiment. Of the three sensors from Group A (KIT1, KIT2 and KIT3) used for this experiment, one of them (KIT2) malfunctioned due to a presumed damage of the ground wire inside the sensor cable. The other two sensors showed stable performance compared to the main experiment, with the error range after the three-point calibration remaining generally consistent with that observed during the main experiment (Figs. 2 and S-18).

The performance of the LCS was also observed with the TS in a field experiment conducted from July to October 2023. The three-point calibration line and the corresponding errors of the validated measurements are illustrated in Fig. S-15. The raw measurements from the LCS (represented as digital values without units) exhibited a strong linear correlation with the reference measurements from the TS. After applying the three-point calibration, most errors fell within the range of [-10, 10] mm, with a few outliers in July showing larger errors up to 20mm. Notably, errors exceeding 10mm accounted for just about 0.05% of the total 85,920 measurements shown in Fig. S-15. This performance was generally consistent with the main lab experiment, confirming the reliability of the LCS under field conditions and suggesting positive potential for long-term reliability and stability.

To evaluate the applicability of one-point calibration using an offset value for quick field adjustments, a comparison was conducted between three-point calibration and one-point calibration. The results (Fig. S-16)

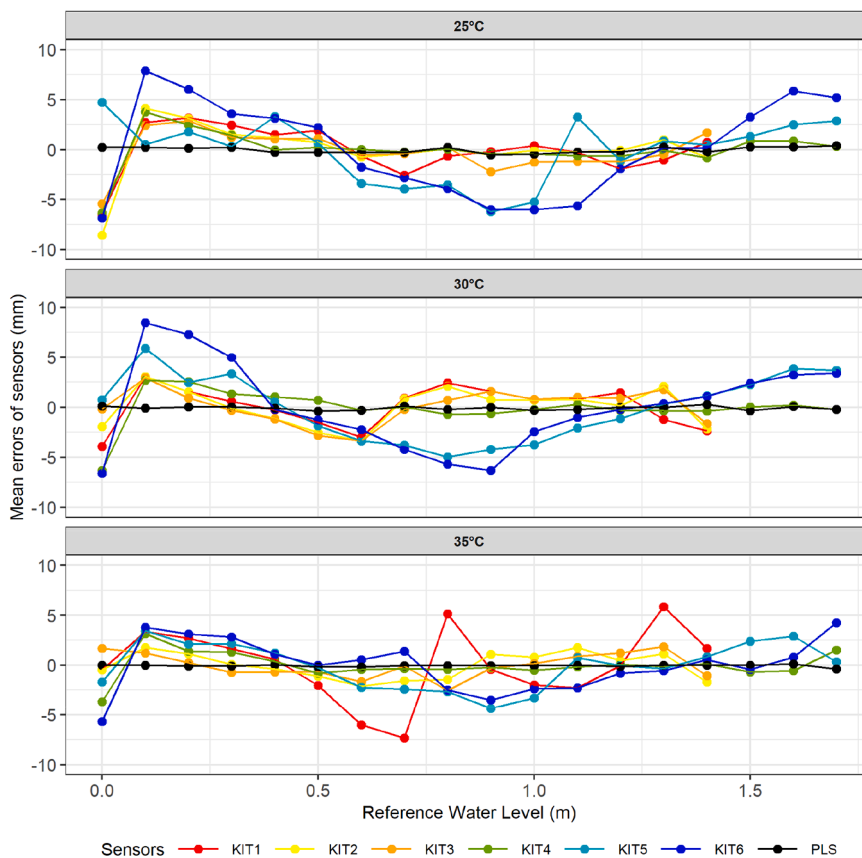

Fig. 4. Mean errors (mm) introduced by the validated measurements of LCS (KIT1-KIT6) compared to the TS (OTT PLS) at three water temperature degrees over the measuring range.

Table 1

Numerical values of accuracy (MAE and RMSE) are shown in this table.

| Type of sensor | | | LCS (Low-cost sensors) | | | | | | TS (Traditional sensor) |
|---------------------------------|----------|------------|-------------------------------|------|------|------|------|------|--------------------------------|
| Sensor names | | | KIT1 | KIT2 | KIT3 | KIT4 | KIT5 | KIT6 | OTT PLS |
| Mean Absolute Error (MAE) | 25 °C | Water Up | 2.14 | 2.33 | 1.89 | 1.23 | 3.05 | 4.99 | 0.52 |
| | | Water Down | 2.93 | 2.34 | 2.19 | 1.22 | 3.74 | 3.81 | 0.06 |
| Unit: mm | 30 °C | Water Up | 1.84 | 1.35 | 1.53 | 1.00 | 4.19 | 4.75 | 0.19 |
| | | Water Down | 3.70 | 3.07 | 2.42 | 1.44 | 2.00 | 2.98 | 0.17 |
| 35 °C | Water Up | Water Up | 5.64 | 1.23 | 1.51 | 1.04 | 2.81 | 2.35 | 0.10 |
| | | Water Down | 2.15 | 2.16 | 2.42 | 1.14 | 1.91 | 2.33 | 0.12 |
| Root Mean Square Error (RMSE) | 25 °C | Water Up | 2.35 | 2.59 | 2.17 | 1.28 | 3.19 | 5.10 | 0.53 |
| | | Water Down | 3.21 | 2.57 | 2.52 | 1.28 | 3.85 | 3.92 | 0.08 |
| Unit: mm | 30 °C | Water Up | 2.04 | 1.60 | 1.72 | 1.07 | 4.30 | 4.83 | 0.27 |
| | | Water Down | 3.84 | 3.27 | 2.63 | 1.50 | 2.14 | 3.08 | 0.25 |
| 35 °C | Water Up | Water Up | 5.78 | 1.50 | 1.80 | 1.10 | 2.91 | 2.49 | 0.14 |
| | | Water Down | 2.34 | 2.38 | 2.65 | 1.21 | 2.06 | 2.47 | 0.17 |
| Accuracy given by Manufacturers | | | 4.4mm of testing range 0~1.7m | | | | | | 0.44mm of testing range 0~1.7m |

showed that the errors associated with the monthly three-point calibration (blue points) are tightly distributed around zero, with an MAE of 1.13mm over the reference water level range for August 2023 and 1.17mm for September 2023, demonstrating the high accuracy of this method. In comparison, the one-point offset calibration (red points), applied after the three-point calibration from July 2023, produces a slightly wider but still comparable error range, with an MAE of 1.29mm for August 2023 and 2.46mm for September 2023. Additionally, the errors for the one-point calibration remained within a smaller range (less than 6mm) compared to the errors (Fig. S-15) associated with using only the three-point calibration line from July 2023 for data in August and September (less than 9mm).

3. Discussion

3.1. Assessment of the performance of the sensors

During the main laboratory experiments, there were around 10,800 measurements from each of the LCS and 1080 measurements from traditional sensor recorded by the Arduino board, over a range of water levels under two water flow directions and at three different water temperatures. The traditional sensor has high reliability with about 0.5mm accuracy compared to the reference water level, confirming that laboratory testing might not be needed for this sensor. No obvious difference of the accuracy and precision was found from the six LCS, but sensor-specific calibration is needed for each individual sensor according to the comparison of calibration lines. As illustrated in Section 2.1,

Table 2

Numerical values of precision (SD and CV) are shown in this table.

| Type of sensor | | | LCS (Low-cost sensors) | | | | | | TS (Traditional sensor) |
|----------------------------------|-------|------------|------------------------|------|------|------|------|------|-------------------------|
| | | | KIT1 | KIT2 | KIT3 | KIT4 | KIT5 | KIT6 | OTT PLS |
| Standard Deviation (SD) Unit: mm | 25 °C | Water Up | 1.05 | 1.26 | 1.30 | 0.33 | 0.90 | 0.83 | 0.06 |
| | | Water Down | 1.23 | 1.31 | 1.37 | 0.37 | 0.90 | 0.87 | 0.06 |
| | 30 °C | Water Up | 0.92 | 1.11 | 1.09 | 0.39 | 0.77 | 0.74 | 0.21 |
| | | Water Down | 0.94 | 1.14 | 1.10 | 0.38 | 0.80 | 0.75 | 0.20 |
| | 35 °C | Water Up | 0.99 | 1.26 | 1.25 | 0.36 | 0.78 | 0.78 | 0.10 |
| | | Water Down | 0.89 | 1.10 | 1.15 | 0.38 | 0.77 | 0.77 | 0.13 |
| Coefficient of Variation (CV), % | 25 °C | Water Up | 0.21 | 0.26 | 0.26 | 0.06 | 0.15 | 0.13 | 0.02 |
| | | Water Down | 0.23 | 0.24 | 0.26 | 0.07 | 0.14 | 0.12 | 0.01 |
| | 30 °C | Water Up | 0.17 | 0.22 | 0.22 | 0.07 | 0.11 | 0.10 | 0.05 |
| | | Water Down | 0.18 | 0.24 | 0.24 | 0.07 | 0.12 | 0.12 | 0.02 |
| | 35 °C | Water Up | 0.18 | 0.28 | 0.28 | 0.07 | 0.13 | 0.12 | 0.02 |
| | | Water Down | 0.15 | 0.20 | 0.22 | 0.07 | 0.11 | 0.11 | 0.03 |

using the calibration line derived from another LCS device could lead to very large errors (MAE more than 100mm). In addition, minimal influence of the water temperature and water flow direction was found for the six low-cost sensors according to the relatively consistent accuracy and precision at two water flow directions (up and down) and three water temperatures (25 °C, 30 °C, 35 °C). The exchangeable calibration lines also indicated that the variation of the water temperature within a limited range (<5 °C) and water flow direction in the field will not be a concern for this low-cost water level sensor monitoring system.

Another main finding from the lab experiments is that the performance of the LCS in measuring water level may be affected by the water level in the field. Specifically, it may give a larger bias when the water depth of the WSUD system is relatively low (under 0.05m) as illustrated in Section 2.2, and manual check found that the current signal from the low-cost sensor became less sensitive when the water pressure became relatively low. This may lead to potential underestimation or overestimation of the water quantity variation of the WSUD system in the field implementation. In addition, the change of wet/dry condition could also slightly affect the performance of the low-cost sensor, as reflected in the increased variability of measurements from sensors in group A (KIT1, KIT2, KIT3) compared to group B (KIT4, KIT5, KIT6), as detailed in Section 2.3. This should be considered in field applications.

There are also other off-the-shelf low-cost water level sensors that have been tested or used in previous studies, including the ultrasonic sensors JSN-SR04T, HC-SR04, MB7092, pressure sensor MS5803-01BA, laser-ranging sensor VL53L0X, etc. (Andang et al., 2019; Cherqui et al., 2020; Nasution et al., 2018). Among them, MS5803-01BA and JSN-SR04T were the best performing sensors in the laboratory: MS5803-01BA presented an accuracy of ± 5 mm for water level up to 2m, and JSN-SR04T showed an accuracy of ± 7 mm in the range 0.225~1.9m. Since the temperature conditions for these two sensors is in [21~25] °C, they can be comparable to the performance of KIT0139 at 25 °C water temperature in our lab testing experiment. KIT0139 has similar accuracy (mean errors within ± 10 mm) for the water level range of 0~1.7m. Overall, the low-cost water level sensor KIT0139 tested in this study has a similar good performance as the two best performing sensors in the previous studies. However, the advantages of the KIT0139 sensor, including its protective casing and vented tube for automatic atmospheric pressure compensation, make it a more promising replacement for traditional sensors in field applications. To our knowledge, our study is the first to test the LCS in high temperatures representative of Tropical climates both in the laboratory and field conditions, which provides confidence in the reliability of the sensors for field implementation in the Tropics. Additionally, our DIY real-time field monitoring system with the low-cost sensor model and its signal processing protocol with fully shareable codes, can be easily adopted and replicated by other practitioners for implementation in tropical regions.

3.2. Practical recommendations of low-cost sensor monitoring system

Considering that the expected accuracy of field application is around ± 20 mm (Cherqui et al., 2020), our results indicate a great potential of the low-cost water level sensor KIT0139 in water quantity monitoring of WSUD systems in the field. We recommend, however, to carefully consider the depth at which the sensor is installed: a minimum depth of 50mm of water will allow continuous immersion of the sensor and avoid measurements in the 0–0.05m range, which seems less reliable. The result from the lab experiments also suggested that limited water temperature variations (<5 °C) would not be a concern in the calibration of the low-cost water level sensor KIT0139, but the calibration for each individual sensor is required for the field implementation. The three-point calibration method has been evaluated and confirmed to be useful for this low-cost water level monitoring system in the field. In practice, a three-point calibration is recommended during the initial installation, which can be performed similarly to the field experiment in this study. However, instead of using the TS to measure reference water levels, manual measurements or a bucket on site can be used. Section 2.5 and Supplementary Material S6 demonstrate that while the regular use of three-point calibration (e.g., on a monthly basis) remains the more precise method, applying one-point calibration as a subsequent adjustment after an initial three-point calibration offers a promising approach to simplify the calibration process in field applications. Nevertheless, the long-term effectiveness of both calibration methods needs to be further investigated.

The results from the main experiment, the three-point calibration experiment and the field experiment demonstrated the good stability of the LCS (KIT0139), as detailed in Section 2.5. These findings suggest positive long-term reliability for the LCS in field implementations. Since the water used for the laboratory experiments was tap water, the water quality in the field may differ, potentially containing more sediments and debris. This could lead to drift in sensor measurements and necessitate manual maintenance of the sensors in the field. In our field experiment, the water indeed contained some sediments and leaf debris, and animal activity was observed in the sump where the sensors were installed, including lizards, frogs, and snakes. However, the sensors were well protected by the stainless-steel casing, and the field maintenance for both the LCS and TS during the experiment was minimal. Nevertheless, the exact long-term reliability and stability of the LCS in field conditions require exploration through extended field applications, and longer-term observations are necessary to fully assess the cost-effectiveness of the LCS compared to the TS. While purchasing price is an important factor, long-term reliability, stability, lifespan, and maintenance costs should also be considered when evaluating the LCS as a replacement for traditional sensors in long-term field applications.

4. Conclusion

This study explored the potential of low-cost sensors in monitoring the performance of Water Sensitive Urban Design systems for urban stormwater management. The performance of a selected low-cost water level sensor (KIT0139) was evaluated alongside a traditional water level sensor (OTT PLS) in laboratory and field experiments. Key indicators of accuracy, including MAE and RMSE, as well as precision indicators such as SD and CV, were assessed under various testing conditions. These conditions included two water flow directions (up and down) and three water temperatures (25 °C, 30 °C, and 35 °C).

The results indicated that the traditional sensor exhibited high reliability and does not require further calibration (though it is always recommended to calibrate sensors during field deployment). This traditional sensor could serve as the reference for field observations of the low-cost sensors. Our laboratory experiment demonstrated that all six low-cost sensors achieved good accuracy and precision, and their performance was not significantly affected by varying water flow directions. However, varying wet and dry conditions slightly influenced the variability of the LCS measurements. Calibration is necessary for each low-cost sensor device during field deployment. Limited water temperature variations (<5 °C) would not be a concern in the calibration of LCS in the field. Our field experiment further confirmed the applicability of three-point calibration and reliability of the LCS in the field conditions. In conclusion, with sufficient accuracy and precision, along with market availability, durability with protective casing, and significant cost advantages compared to traditional sensors, the low-cost sensor device tested in this study is recommended to be used in the WSUD monitoring that requires to be widely promoted with no more strict restriction of accuracy.

For future work, alternative low-cost sensors, including pressure, ultrasonic, laser, and radar sensors with promising advantages, should be identified and tested in both laboratory and field settings for various WSUD designs that require different measuring ranges and accuracy restrictions. Additionally, the long-term reliability, stability, lifespan, and maintenance costs of low-cost sensors should be further explored in field applications.

5. Methodology

5.1. Laboratory experimental setup

The lab testing platform (Fig. 5) mainly consists of the following key

components: an acrylic water column, water level sensors, a microcontroller (Arduino MKR1310 board), a water temperature controller (PolyScience Heated Circulators machine Heated Circulators 2024), a water tank, pumps and an online control platform (Arduino IDE software). The water used was tap water. The water level testing range was designed to be 0~1.7m since our application of water level monitoring mainly focuses on WSUD systems where the water depth is normally less than 1.5m. The sensors were tested for a measuring range of 0~1.7m, under three water temperatures (25 °C, 30 °C, 35 °C). Each experiment included one complete cycle (two water flow directions) of filling the water column to the maximum height of 1.7m (upper limit) with an increment of 0.1m, followed by emptying to the minimum height of 0m (lower limit) with a decrement of 0.1m. After reaching each water level, there was a 10-second stabilization time before recording readings from the LCS and TS sensors. The reference water level was measured visually with a graduated ruler (1mm mark). In addition, the water temperature was recorded by the traditional sensor (OTT PLS) during the water level measurements.

5.1.1. Preliminary lab experiment

From March 28 to 29, 2022, a preliminary experiment was conducted to evaluate the performance of one LCS (KIT0139, referred to as KIT0) alongside the TS (OTT PLS) using the experimental setup described earlier. During this preliminary test, 20 measurements were recorded from both the LCS and TS at each water level. The circuit schematic for the electrical design of the low-cost and traditional water level sensors used in the preliminary lab experiment is illustrated in Fig. S-1. The Arduino Mega 2560 board served as the microcontroller to communicate with the sensors. The SDI-12 output from the TS was directly read by the Arduino board through its digital pin. However, the 4~20mA analog current output from the LCS could not be directly read by the Arduino. To address this, an analog current-to-voltage converter (SEN0262) with 120Ω termination resistor, which is the default converter in the KIT0139 measurement kit, was used. This converter transformed the 4~20mA current signal from the LCS into a 0.48~2.4V voltage signal, making it compatible with the Arduino board.

5.1.2. Main lab experiment

On March 31, 2023, six LCS (KIT0139, labelled KIT1 through KIT6) and one TS (OTT PLS), were tested in the laboratory following the procedure described in the first paragraph of Section 5.1. To assess the impact of varying wetting and drying conditions – common in flashy stormwater catchments – on sensor performance, the LCS devices were

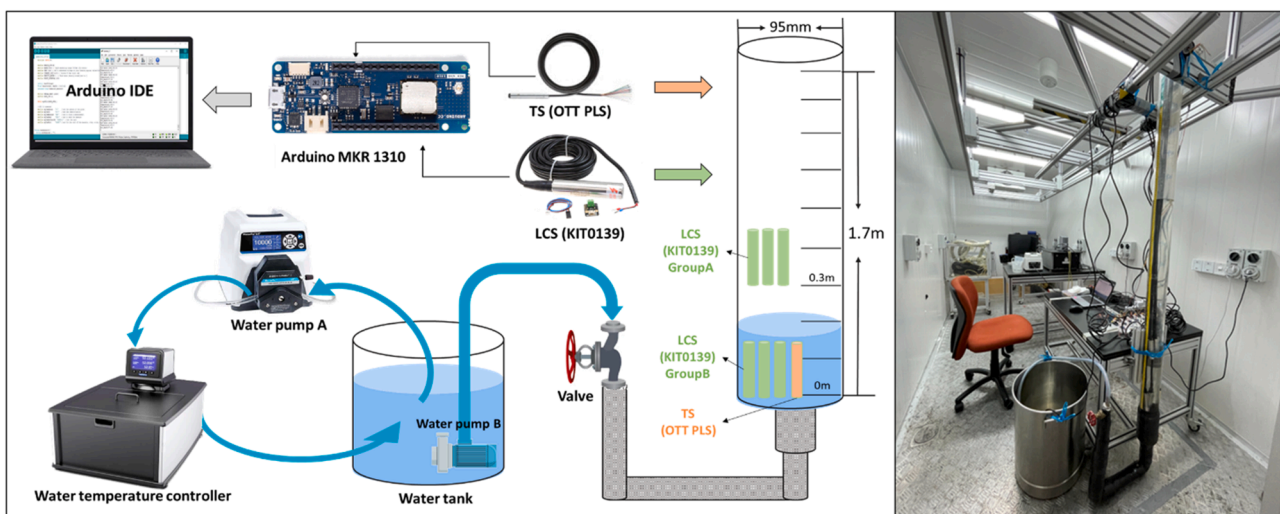

Fig. 5. Experimental setup for the main lab experiment. Six LCS and one TS were tested in a water column over a range of 0~1.7m, with three LCS at 0m water level and the other three LCS at 0.3m. Group A corresponds to LCS sensors KIT1, KIT2 and KIT3, while group B corresponds to LCS sensors KIT4, KIT5 and KIT6.

divided into two groups, each containing three sensors. As shown in Fig. 5, group B (KIT4, KIT5, KIT6) of LCS was positioned at the 0m level (always submerged in water), while group A (KIT1, KIT2, KIT3) was placed at 0.3m level with a variety of dry and wet conditions. The total testing time for each cycle (involving two water flow directions at one water temperature) was approximately 72 minutes, and the exposure time for group A was about 8 minutes under dry conditions between the two testing cycles. Additionally, testing three LCS from each group at the same time aimed to check if there is a distinct difference between the individual LCS device.

At each water level, 100 readings were recorded from the LCS and 10 from the TS. The reason for recording one TS measurement for every 10 LCS measurements was that it took approximately 30 seconds for the Arduino to gather 100 readings from the LCS (KIT0139), whereas it required around 60 seconds to obtain 10 readings from the TS (OTT PLS). This approach allowed for more LCS readings to provide better information on precision assessment, while fewer readings from the TS – whose precision had already been confirmed in the preliminary experiment – helped reduce overall testing time and minimized potential drift or temperature fluctuations during each cycle.

The electrical design for the main lab experiment was optimized based on insights from the preliminary experiment, with the updated circuit schematic shown in Fig. 6. The major optimization was upgrading the signal processing protocol for the LCS (KIT0139). Since the precision of the LCS (KIT0139) tested in the preliminary experiment was unsatisfactory (Fig. S-2), the signal measurement was optimized with new components in the main lab experiment. Specifically, the analog current-to-voltage converter (SEN0262) used in the preliminary experiment was replaced with a system offering a better resolution and accuracy. A 250-ohm (R1) high-precision resistor was used to convert the 4~20mA current into a 1~5V voltage, enabling more precise measurement of the LCS output. Additionally, an analog-to-digital converter DFR0553 based on the ADS1115 chip (U2) was used to read out the voltage and convert the signal to a 16-bit resolution digital signal (better than the Arduino board's 10-bit resolution) to communicate with the Arduino board. The TS (OTT PLS) continued to use the SDI-12 signal output to directly communicate with Arduino board, as in the preliminary experiment. Another improvement was preparing the system for field deployment. This was achieved by replacing the Arduino Mega

2560 board with the Arduino MKR 1310 board (U1), which supports real-time data transmission for future field implementation. Both the OTT PLS sensor (U6) and the KIT0139 sensor (U5) were powered using a 24V power supply, enabled by the Arduino's 5V output and the MT3608 voltage converter modules (U3, U4). This setup allowed for all electrical connections to be integrated onto a DIY PCB board, making the system easier to deploy and maintain in the field. It was important to connect both OTT PLS sensor and KIT0139 sensor to the same power supply for the process of comparing measurement performance, to the detriment of studying the consumption of the low-cost sensor. The Arduino MKR 1310 board was directly connected to the computer via USB port, and data was recorded through the Arduino Integrated Development Environment (IDE) software. To determine the correlation between the recorded signal from the low-cost sensor (KIT0139) and the water level, a calibration function is needed (see Section S5 in Supplementary Material).

5.1.3. Three-point calibration lab experiment

On December 15, 2023, a new experiment was conducted to gather data for a three-point calibration. This experiment focused solely on the LCS sensors in Group A (Fig. 5) and tested within a range of 0 to 0.6 m, with water levels increasing in 0.1-meter increments under a constant water temperature of 25 °C. During the experiment, it was observed that the LCS KIT2 sensor appeared to be malfunctioning after being left on the testing platform for approximately eight months. The likely cause of the malfunction was a damage of the ground wire inside the sensor cable.

Finally, we also tested a one-point calibration approach using data from August and September 2023 collected during the field experiment under two scenarios: (1) applying three-point calibration in July 2023, followed by one-point calibration using an offset value calculated from the first data point of each month to adjust LCS measurements for August and September 2023; and (2) directly applying three-point calibration to the LCS measurements on a monthly basis for August and September 2023.

5.1.4. Three-month field experiment

A real-time monitoring station was established at the outlet sump of a Rain Garden in Singapore to assess sensor performance under field

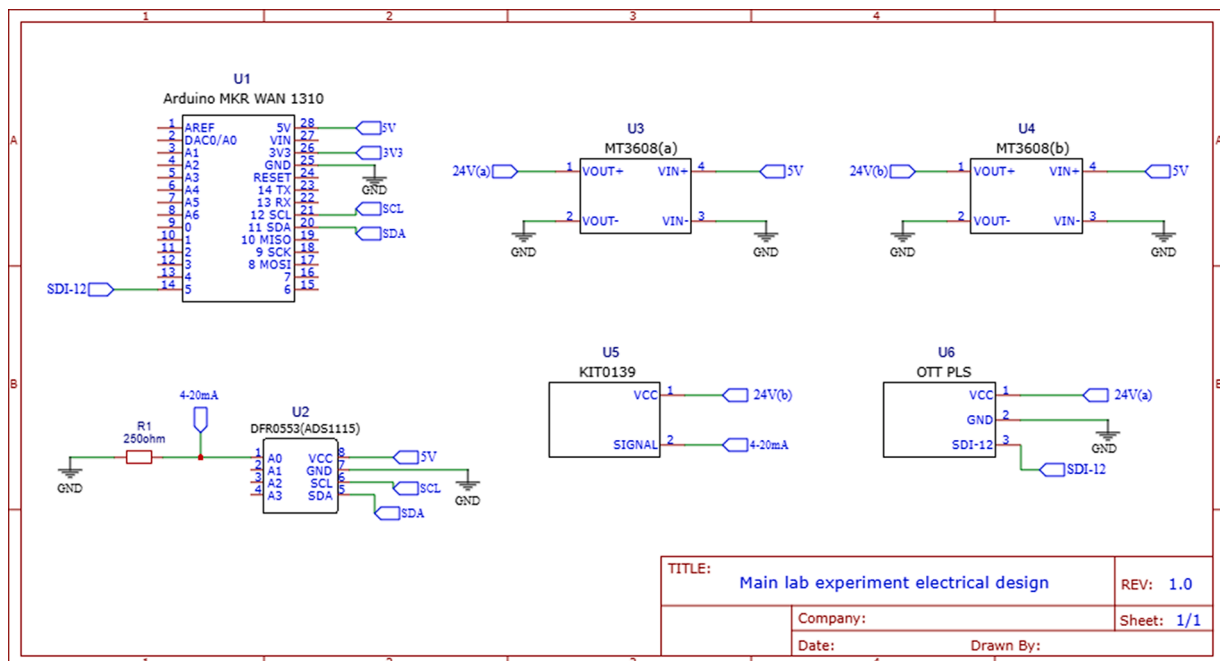

Fig. 6. Circuit schematic for the electrical design for the low-cost and traditional water level sensors in the main lab experiment.

conditions from July to October 2023. The station consisted of an Arduino MKR1310 microcontroller board, an Arduino MKR Mem Shield, an SD card, a Lilygo ESP32 LoRa module, two antennas, two MT3608 voltage converters, a low-cost water level sensor (KIT0139), a traditional water level sensor (OTT PLS), an ADS1115 module, a 250-ohm resistor, a digital temperature sensor (DS18B20) with a 4.7k resistor, and a real-time clock module (DS3231). These components were integrated into a DIY PCB board housed in a waterproof enclosure (Fig. S-14) to ensure durability in outdoor conditions. Power for the station was supplied by a nearby solar panel. A V-notch weir (Fig. S-14) was installed at the outlet pipe to maintain water levels above 0.05 m, enhancing the reliability of measurements from the LCS, as discussed in Section 2.2. During the experiment, the monitoring station recorded 10 measurements from the LCS, one measurement from the TS and one measurement from the temperature sensor every 5 minutes, with data stored locally on an SD card and transmitted in real time to an online Google Sheet for storage and further analysis. Details of the monitoring station’s design protocol are illustrated in Fig. S-11, and additional information is provided in Section S6 of the Supplementary Material.

Real-time data transmission was facilitated through communication between the Arduino MKR1310 board and the Lilygo ESP32 LoRa module. The Lilygo receiver, positioned in a laboratory approximately 200m from the Rain Garden, and connected to the internet via a Wi-Fi router in the same lab (Fig. S-12). The data received by the Lilygo receiver was sent to an online Google Sheet via the IFTTT (If This Then That) platform, which created an applet enabling the Lilygo module to transmit the data using HTTP and JSON. The applet then forwarded the data to Google Sheets. The transmitted data was also displayed in real time on the Opendataeau platform (<https://opendataeau.org/>). To ensure data integrity, the Lilygo receiver sent the received data back to the Arduino board for verification, confirming consistency between transmitted and received data packages (Fig. S-13). Further details of the transmission and verification process are provided in Section S6 of the

Supplementary Material.

With the design of V-notch weir, only water levels measured by the TS above 0.042m (including a 1.5cm offset due to the height of the protective cap) were considered for the calibration and assessment of LCS. This threshold accounts for the 0.008m difference in ground level between the two sensors in the field setup. Three random points were generated from the following ranges of water levels: [0.042, 0.062]m, [0.062, 0.082]m, and [0.082, 0.102]m in the field data collected in July 2023. These points were used to create the three-point calibration line, which in turn validated the observed field measurements from the LCS.

5.2. Sensor calibration and performance assessment

Fig. 7 shows the methodology used for the sensor calibration and performance assessment in this study. The following sections describe the methods for the performance assessment of the sensors, including the accuracy, precision, and sensitivity to the water temperature. To identify whether there is a universal calibration function for the low-cost sensor model tested in this study, and with the aim to simplify the sensor calibration process, the calibration lines for the six LCS were compared under each testing condition, and the potential of three-point calibration was explored.

5.2.1. Sensor calibration and validation

The first order ordinary least squares regression (OLS) method was used for the calibration of the sensors tested in this study, based on the consideration of goodness of fit and appropriate complexity. The calibration line was generated by using the reference water level measured visually with a graduated ruler (1mm mark) as X-axis and the raw measurements by the sensors as Y-axis. The calibration line for the LCS and TS, under each water flow direction and water temperature, can be presented by Eq. 1. Then the validation of the sensor measurements can be represented by Eq. 2. The calibration lines were generated, and the

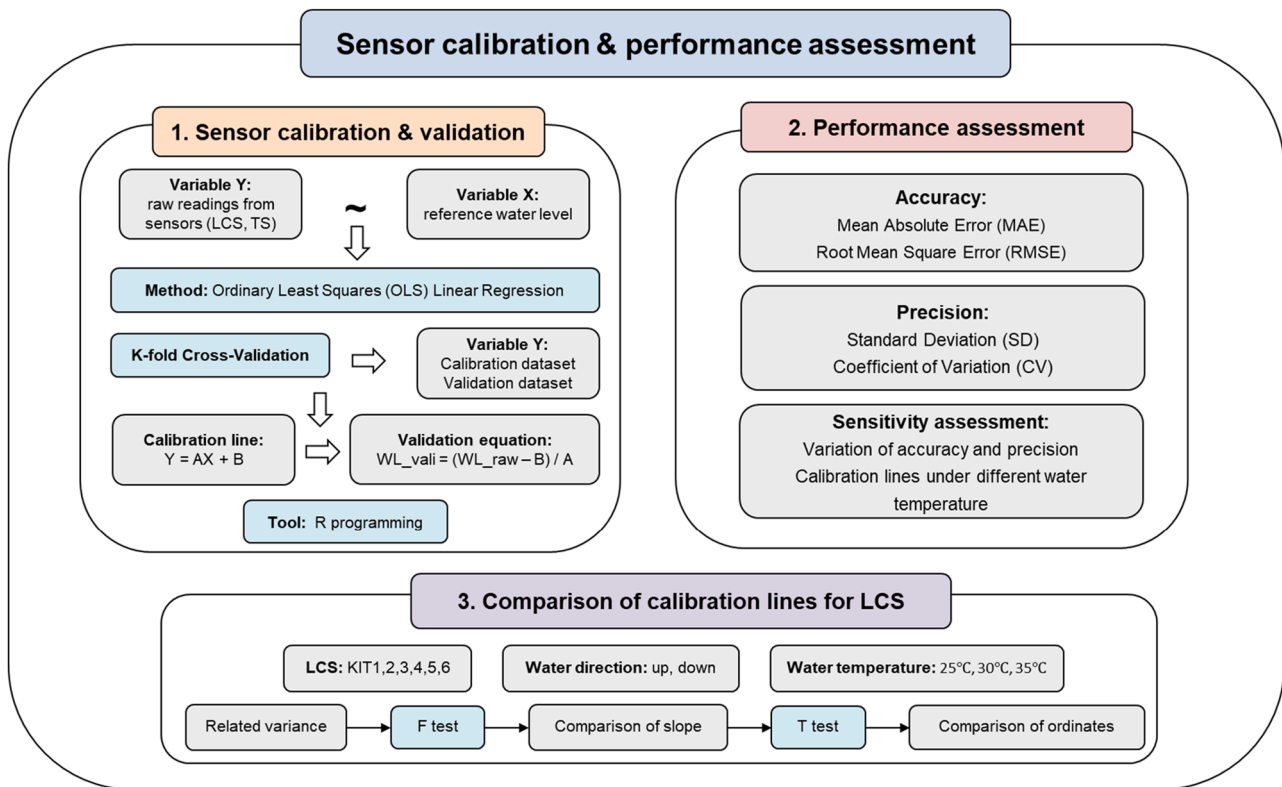

Fig. 7. Framework for evaluating the performance of LCS and TS in lab testing experiments. The performance of the LCS and TS was assessed by their accuracy, precision, and sensitivity to water temperature.

validation was done in R (v4.3.1). To identify whether there is a universal calibration line for the LCS, statistical analyses including F test and T test were done to compare the calibration lines from each individual LCS, each water flow direction, and each water temperature.

To divide the calibration and validation dataset, k-fold cross validation method was used to determine the proportion of calibration and validation to the original dataset from the sensor measurements. According to the Mean Absolute Error (MAE) from the k-fold cross validation, the 100 measurements from the LCS (KIT0139) taken at each water level were divided into two equal datasets: one dataset including 50 measurements at each water level was used for generating the calibration lines, while the other dataset including the other 50 measurements at each water level was used for the validation to obtain the validated water level measurements and assess the performance of the LCS. Similarly, 10 measurements by TS (OTT PLS) recorded at each water level were divided into two datasets, each including 5 measurements at each water level.

$$Y_{ij} = AX_i + B \quad (1)$$

Where:

- X_i represents the 18 reference water level values measured with the graduated ruler over the testing ranging of 0~1.7m, where $i = 1, 2, \dots, 18$.
- For each X_i , there are 50 corresponding LCS measurements used to generate the calibration line, denoted as Y_{ij} , where $j = 1, 2, \dots, 50$. For the TS, there are 5 measurements, represented as Y_{ij} , where $j = 1, 2, \dots, 5$.
- A is the slope of the line, representing the change in LCS or TS measurement per unit change in water level.
- B is the intercept, representing the LCS or TS measurement when the water level is zero.

$$WL_{valij} = \frac{(WL_{rawij} - B)}{A} \quad (2)$$

Where:

- WL_{rawij} refers to the raw measurements from the LCS or TS over the measuring range of 0~1.7m. Where i represents the 18 reference water levels, with $i = 1, 2, \dots, 18$. And j is the corresponding 50 LCS measurements ($j = 1, 2, \dots, 50$) or 5 TS measurements ($j = 1, 2, \dots, 5$) used for validation.
- WL_{valij} represents the validated measurements from the LCS or TS corresponding to the WL_{rawij} values.

5.2.2. Assessment of reliability, accuracy, and precision

We assessed accuracy, represented by the commonly used parameters including Mean Absolute Error (MAE) and Root Mean Square Error (RMSE) (Zhu et al., 2023), the calculations for these two statistics are shown in Eq. 3 and Eq. 4. Precision, defined here as the variance of measurements over the measuring range, and was quantified based on Standard Deviation (SD) and Coefficient of Variation (CV) (Levy Zamora et al., 2019), which are represented in Eq. 5 and Eq. 6. These indicators were calculated for each water level and then averaged over the whole testing range (0~1.7m).

$$MAE = \frac{1}{n \times m} \sum_{i=1}^n \sum_{j=1}^m |WL_{valij} - X_i| \quad (3)$$

$$RMSE = \sqrt{\frac{1}{n \times m} \sum_{i=1}^n \sum_{j=1}^m (WL_{valij} - X_i)^2} \quad (4)$$

Where:

- $n = 18$ represents the total number of reference water levels.
- m represents the total number of validated measurements from the sensor at each reference water level ($m = 50$ for LCS, and $m = 5$ for TS).
- WL_{valij} is the validated measurement from either the LCS or TS for reference water level X_i .
- X_i is the reference water level values, with $i = 1, 2, \dots, 18$.
- j represents the number of validated measurements for each water level. ($j = 1, 2, \dots, 50$ for LCS, and $j = 1, 2, \dots, 5$ for TS).

$$SD = \sqrt{\frac{1}{n \times m} \sum_{i=1}^n \sum_{j=1}^m (WL_{valij} - \overline{WL_{val}})^2} \quad (5)$$

Where:

- $n = 18$ represents the total number of reference water levels.
- m represents the total number of validated measurements from the sensor at each reference water level ($m = 50$ for LCS, and $m = 5$ for TS).
- WL_{valij} is the validated measurement from either the LCS or TS for reference water level X_i .
- X_i is the reference water level values, with $i = 1, 2, \dots, 18$.
- $\overline{WL_{val}}$ is the mean of the validated measurements calculated as:

$$\overline{WL_{val}} = \frac{1}{n \times m} \sum_{i=1}^n \sum_{j=1}^m WL_{valij} \quad (6)$$

$$CV = \frac{SD}{\overline{WL_{val}}} \times 100$$

Where:

- SD is the standard deviation of the validated measurements over the measuring range except for 0m.
- $\overline{WL_{val}}$ is the mean of the validated measurements over the measuring range except for 0m.

To assess the potential differences between the individual LCS devices and the performance varying over time, which we term here as reliability, we systematically performed the analyses on each sensor's data and compared the calibration and performance assessment.

5.2.3. Sensitivity to water temperature

The manufacturer states that the LCS (KIT0139) features built-in temperature compensation technology, which means that its signal output should be compensated for the effects of temperature on water density. However, there was no information provided on the temperature correction, unlike for the TS (OTT PLS) that has real-time temperature measurements. Therefore, it is important to test and evaluate whether temperature compensation technology of the LCS performs as effectively as that of the TS. In this study, the sensitivity of the LCS to water temperature was assessed based on the variation of sensors' accuracy (MAE and RMSE) and precision (SD and CV) with the temperature varying from 25 to 35 °. Additionally, the impact of water temperature on the calibration of the LCS was examined by comparing calibration lines at different temperatures.

CRedit authorship contribution statement

Ning Ding: Writing – review & editing, Writing – original draft, Visualization, Software, Methodology, Investigation, Formal analysis, Data curation, Conceptualization. **Qingchuan Zhu:** Writing – review & editing, Methodology, Conceptualization. **Frederic Cherqui:** Writing – review & editing, Writing – original draft, Supervision, Resources, Funding acquisition, Conceptualization. **Nicolas Walcker:** Writing – review & editing, Conceptualization. **Jean-Luc Bertrand-Krajewski:** Writing – review & editing, Conceptualization. **Perrine Hamel:** Writing – review & editing, Writing – original draft, Supervision, Resources, Funding acquisition, Conceptualization.

Declaration of competing interest

The authors declare the following financial interests/personal relationships which may be considered as potential competing interests:

Perrine Hamel and Frederic Cherqui reports financial support was provided by MERLION (French embassy in Singapore and Nanyang Technological University). Perrine Hamel reports financial support was provided by Singapore National Research Foundation. Frederic Cherqui and Jean-Luc Bertrand-Krajewski reports financial support was provided by Rhône-Méditerranée-Corse Water Agency. If there are other authors, they declare that they have no known competing financial interests or personal relationships that could have appeared to influence the work reported in this paper.

Acknowledgment

ND, PH, QZ, FC, NW, and JLBK acknowledge the support from Nanyang Technological University and the French Ministry of Foreign Affairs through a MERLION grant. QZ, FC, NW and JLBK also acknowledge the Co-UDlabs Project (GA 101008626) and the support from the Rhône-Méditerranée-Corse Water Agency, Lyon, France. In France, this research was performed within the framework of the OTHU (www.othu.org) and the Graduate School H2O'Lyon (ANR-17-EURE-0018). PH acknowledges the support of the Singapore National Research Foundation, Prime Minister's Office (NRF-NRFF12-2020-0009). QZ acknowledges the support of the China Scholarship Council (PhD grant contract 201806560056). We also thank Dr Benoit Taisne for the laboratory space, and Dr Ji-Jon Sit, Encillo Jeffrey Avila, and Quek Kah Hou, Darren for their help with field implementation.

Supplementary materials

Supplementary material associated with this article can be found, in the online version, at [doi:10.1016/j.wroa.2024.100298](https://doi.org/10.1016/j.wroa.2024.100298).

Data availability

Data will be made available on request

References

- Alam, A.U., Clyne, D., Deen, M.J., 2021. A low-cost multi-parameter water quality monitoring system. *Sensors* 21 (11), 3775. <https://doi.org/10.3390/s21113775>.
- Ali, A.S., Zanzinger, Z., Debose, D., Stephens, B., 2016. Open Source Building Science Sensors (OSBSS): A low-cost Arduino-based platform for long-term indoor environmental data collection. *Build. Environ.* 100, 114–126. <https://doi.org/10.1016/j.buildenv.2016.02.010>.
- Andang, A., Hiron, N., Chobir, A., Busaeri, N., 2019. Investigation of ultrasonic sensor type JSN-SRT04 performance as flood elevation detection. In: *IOP Conference Series: Materials Science and Engineering*, 550, 012018. <https://doi.org/10.1088/1757-899X/550/1/012018>.
- Bellezoni, R.A., Meng, F., He, P., Seto, K.C., 2021. Understanding and conceptualizing how urban green and blue infrastructure affects the food, water, and energy nexus: A synthesis of the literature. *J. Clean. Product.* 289, 125825. <https://doi.org/10.1016/j.jclepro.2021.125825>.

- Bertrand-Krajewski, J.-L., Clemens-Meyer, F., Lepot, M. (Eds.), 2021. *Metrology in Urban Drainage and Stormwater Management: Plug and Pray*. IWA Publishing.
- Catsamas, S., Shi, B., Wang, M., Xiao, J., Kolotelo, P., McCarthy, D., 2023. A low-cost radar-based IoT sensor for noncontact measurements of water surface velocity and depth. *Sensors* 23 (14), 6314. <https://doi.org/10.3390/s23146314>.
- Chan, K., Schillereff, D.N., Baas, A.C., Chadwick, M.A., Main, B., Mulligan, M., O'Shea, F. T., Pearce, R., Smith, T.E., Van Soesbergen, A., Tebbs, E., Thompson, J., 2021. Low-cost electronic sensors for environmental research: Pitfalls and opportunities. *Progr. Phys. Geogr.: Earth Environ.* 45 (3), 305–338. <https://doi.org/10.1177/0309133320956567>.
- Chang, H., Pallathadka, A., Sauer, J., Grimm, N.B., Zimmerman, R., Cheng, C., Iwaniec, D.M., Kim, Y., Lloyd, R., McPhearson, T., Rosenzweig, B., Troxler, T., Wely, C., Brenner, R., Herrerros-Cantis, P., 2021. Assessment of urban flood vulnerability using the social-ecological-technological systems framework in six US cities. *Sustain. Citi. Soc.* 68, 102786. <https://doi.org/10.1016/j.scs.2021.102786>.
- Cherqui, F., James, R., Poelsma, P., Burns, M.J., Szota, C., Fletcher, T., Bertrand-Krajewski, J.-L., 2020. A platform and protocol to standardise the test and selection low-cost sensors for water level monitoring. *H2Open J.* 3 (1), 437–456. <https://doi.org/10.2166/h2oj.2020.050>.
- Dswilan, S., Harmadi, Marzuki, 2021. Flood monitoring system using ultrasonic sensor SN-SR04T and SIM 900A. *J. Phys.: Conferen. Ser.* 1876 (1), 012003. <https://doi.org/10.1088/1742-6596/1876/1/012003>.
- Espinoza Ortiz, M., Apún Molina, J.P., Belmonte Jiménez, S.I., Herrera Barrientos, J., Peinado Guevara, H.J., Santamaria Miranda, A., 2023. Development of low-cost IoT system for monitoring piezometric level and temperature of groundwater. *Sensors* 23 (23), 9364. <https://doi.org/10.3390/s23239364>.
- Gleason, J.A., Casiano Flores, C., 2021. Challenges of water sensitive cities in Mexico: the case of the metropolitan area of Guadalajara. *Water* 13 (5), 601. <https://doi.org/10.3390/w13050601>.
- Gonzaga, B.A., Alves, D.L., Albuquerque, M.D.G., Espinoza, J.M.D.A., Almeida, L.P., Weschenfelder, J., 2020. Development of a low-cost ultrasonic sensor for groundwater monitoring in coastal environments: validation using field and laboratory observations. *J. Coast. Res.* 95 (sp1), 1001. <https://doi.org/10.2112/S195-195.1>.
- Gunnell, K., Mulligan, M., Francis, R.A., Hole, D.G., 2019. Evaluating natural infrastructure for flood management within the watersheds of selected global cities. *Sci. Tot. Environ.* 670, 411–424. <https://doi.org/10.1016/j.scitotenv.2019.03.212>.
- Hamel, P., Ding, N., Cherqui, F., Zhu, Q., Walcker, N., Bertrand-Krajewski, J.-L., Champrasert, P., Fletcher, T.D., McCarthy, D.T., Navratil, O., Shi, B., 2024. Low-cost monitoring systems for urban water management: Lessons from the field. *Water Res.* X 22, 100212. <https://doi.org/10.1016/j.wroa.2024.100212>.
- Hamel, P., Tan, L., 2021. Blue-green infrastructure for flood and water quality management in Southeast Asia: evidence and knowledge gaps. *Environ. Manage.* 69 (4), 699–718. <https://doi.org/10.1007/s00267-021-01467-w>.
- Heated Circulators | *PolyScience*. (n.d.). Retrieved December 10, 2024, from <https://www.polyscience.com/products/circulating-baths/heated-circulators>.
- Intharasombat, O., Khoenkaw, P., 2015. A low-cost flash flood monitoring system. In: *2015 7th International Conference on Information Technology and Electrical Engineering (ICITEE)*, pp. 476–479. <https://doi.org/10.1109/ICITEED.2015.7408993>.
- Kalyanapu, A., Owusu, C., Wright, T., Datta, T., 2023. Low-cost real-time water level monitoring network for falling water river watershed: a case study. *Geosciences* 13 (3), 65. <https://doi.org/10.3390/geosciences13030065>.
- Keesstra, S., Nunes, J., Novara, A., Finger, D., Avelar, D., Kalantari, Z., Cerdà, A., 2018. The superior effect of nature based solutions in land management for enhancing ecosystem services. *Sci. Tot. Environ.* 610–611, 997–1009. <https://doi.org/10.1016/j.scitotenv.2017.08.077>.
- Kombo, O.H., Kumaran, S., Bovim, A., 2021. Design and application of a low-cost, low-power, LoRa-GSM, IoT enabled system for monitoring of groundwater resources with energy harvesting integration. *IEEE Access* 9, 128417–128433. <https://doi.org/10.1109/ACCESS.2021.3112519>.
- Koshoeva, B.B., Mikheeva, N.I., Mikheev, D.I., Bakalova, A.T., 2021. Arduino-based automated system for determining water flow consumption in open flow. *J. Phys.: Conferen. Ser.* 2142 (1), 012009. <https://doi.org/10.1088/1742-6596/2142/1/012009>.
- Kuller, M., Bach, P.M., Ramirez-Lovering, D., Deletic, A., 2017. Framing water sensitive urban design as part of the urban form: A critical review of tools for best planning practice. *Environ. Modell. Softw.* 96, 265–282. <https://doi.org/10.1016/j.envsoft.2017.07.003>.
- Kuller, M., Bach, P.M., Roberts, S., Browne, D., Deletic, A., 2019. A planning-support tool for spatial suitability assessment of green urban stormwater infrastructure. *Sci. Tot. Environ.* 686, 856–868. <https://doi.org/10.1016/j.scitotenv.2019.06.051>.
- Levy Zamora, M., Xiong, F., Gentner, D., Kerkez, B., Kohrman-Glaser, J., Koehler, K., 2019. Field and laboratory evaluations of the low-cost plantower particulate matter sensor. *Environ. Sci. Technol.* 53 (2), 838–849. <https://doi.org/10.1021/acs.est.8b05174>.
- Loizou, K., Koutroulis, E., 2016. Water level sensing: State of the art review and performance evaluation of a low-cost measurement system. *Measurement* 89, 204–214. <https://doi.org/10.1016/j.measurement.2016.04.019>.
- Mao, F., Khamis, K., Clark, J., Krause, S., Buytaert, W., Ochoa-Tocachi, B.F., Hannah, D. M., 2020. Moving beyond the Technology: A Socio-technical Roadmap for Low-Cost Water Sensor Network Applications. *Environ. Sci. Technol.* 54 (15), 9145–9158. <https://doi.org/10.1021/acs.est.9b07125>.
- Mao, F., Khamis, K., Krause, S., Clark, J., Hannah, D.M., 2019. Low-cost environmental sensor networks: recent advances and future directions. *Front. Earth Sci.* 7, 221. <https://doi.org/10.3389/feart.2019.00221>.

- Morawska, L., Thai, P.K., Liu, X., Asumadu-Sakyi, A., Ayoko, G., Bartonova, A., Bedini, A., Chai, F., Christensen, B., Dunbabin, M., Gao, J., Hagler, G.S.W., Jayaratne, R., Kumar, P., Lau, A.K.H., Louie, P.K.K., Mazaheri, M., Ning, Z., Motta, N., Williams, R., 2018. Applications of low-cost sensing technologies for air quality monitoring and exposure assessment: How far have they gone? *Environ. Int.* 116, 286–299. <https://doi.org/10.1016/j.envint.2018.04.018>.
- Nasution, T.H., Siagian, E.C., Tanjung, K., Soeharwinto, 2018. Design of river height and speed monitoring system by using Arduino. *IOP Conferen. Ser.: Mater. Sci. Eng.* 308, 012031. <https://doi.org/10.1088/1757-899X/308/1/012031>.
- Parra, L., Sendra, S., Lloret, J., Rodrigues, J.J.P.C., 2017. Design and deployment of a smart system for data gathering in aquaculture tanks using wireless sensor networks. *Int. J. Commun. Syst.* 30 (16), e3335. <https://doi.org/10.1002/dac.3335>.
- Patil, P.S., Kaggate, P.D., Rathour, S.B., Mawale, N.P., & Khope, R.G. (2020). *Water Level Monitoring and Leakage Detection System using Long Range Module (LoRa)*. 12(2).
- Paul, J.D., Buytaert, W., Sah, N., 2020. A Technical Evaluation of Lidar-Based Measurement of River Water Levels. *Water Resour. Res.* 56 (4), e2019WR026810. <https://doi.org/10.1029/2019WR026810>.
- Pearce, R.H., Chadwick, M.A., Main, B., Chan, K., Sayer, C.D., Patmore, I.R., 2024. Low-cost approach to an instream water depth sensor construction using differential pressure sensors and arduino microcontrollers. *Sensors* 24 (8), 2488. <https://doi.org/10.3390/s24082488>.
- Rangari, V.A., Umamahesh, N.V., Patel, A.K., 2021. Flood-hazard risk classification and mapping for urban catchment under different climate change scenarios: A case study of Hyderabad city. *Urban Clim.* 36, 100793. <https://doi.org/10.1016/j.uclim.2021.100793>.
- Reu Junqueira, J., Serrao-Neumann, S., White, I., 2021. A systematic review of approaches for modelling current and future impacts of extreme rainfall events using green infrastructure. *J. Clean. Product.* 290, 125173. <https://doi.org/10.1016/j.jclepro.2020.125173>.
- Segovia-Cardozo, D.A., Rodríguez-Sinobas, L., Canales-Ide, F., Zubezcu, S., 2021. Design and Field Implementation of a Low-Cost, Open-Hardware Platform for Hydrological Monitoring. *Water* 13 (21), 3099. <https://doi.org/10.3390/w13213099>.
- Shi, B., Catsamas, S., Kolotelo, P., Wang, M., Lintern, A., Jovanovic, D., Bach, P.M., Deletic, A., McCarthy, D.T., 2021. A low-cost water depth and electrical conductivity sensor for detecting inputs into urban stormwater networks. *Sensors* 21 (9), 3056. <https://doi.org/10.3390/s21093056>.
- Shrenika, R.M., Chikmath, S.S., Kumar, A.V.R., Divyashree, Y.V., Swamy, R.K., 2017. Non-contact water level monitoring system implemented using LabVIEW and Arduino. In: 2017 International Conference on Recent Advances in Electronics and Communication Technology (ICRAECT), pp. 306–309. <https://doi.org/10.1109/ICRAECT.2017.51>.
- Sun, C.-Y., Kato, S., Gou, Z., 2019. Application of low-cost sensors for urban heat island assessment: a case study in Taiwan. *Sustainability* 11 (10), 2759. <https://doi.org/10.3390/su11102759>.
- Tabada, M.T., Loretero, M.E., Lasta, F.F., 2020. Investigation on the performance of a multi-wire water level detection system using contact sensing for river water monitoring. *SN Appl. Sci.* 2 (1), 77. <https://doi.org/10.1007/s42452-019-1887-0>.
- Tzoulas, K., Korpela, K., Venn, S., Yli-Pelkonen, V., Kazmierczak, A., Niemela, J., James, P., 2007. Promoting ecosystem and human health in urban areas using Green Infrastructure: A literature review. *Landsc. Urban Plann.* 81 (3), 167–178. <https://doi.org/10.1016/j.landurbplan.2007.02.001>.
- Valente, A., Silva, S., Duarte, D., Cabral Pinto, F., Soares, S., 2020. Low-Cost LoRaWAN Node for Agro-Intelligence IoT. *Electronics* 9 (6), 987. <https://doi.org/10.3390/electronics9060987>.
- Yau, W., Radhakrishnan, M., Liong, S.-Y., Zevenbergen, C., Pathirana, A., 2017. Effectiveness of ABC waters design features for runoff quantity control in urban Singapore. *Water* 9 (8), 577. <https://doi.org/10.3390/w9080577>.
- Yin, D., Chen, Y., Jia, H., Wang, Q., Chen, Z., Xu, C., Li, Q., Wang, W., Yang, Y., Fu, G., Chen, A.S., 2021. Sponge city practice in China: a review of construction, assessment, operational and maintenance. *J. Clean. Product.* 280, 124963. <https://doi.org/10.1016/j.jclepro.2020.124963>.
- Zhang, D., Heery, B., O'Neil, M., Little, S., O'Connor, N.E., Regan, F., 2019. A low-cost smart sensor network for catchment monitoring. *Sensors* 19 (10), 2278. <https://doi.org/10.3390/s19102278>.
- Zhu, Q., Cherqui, F., Bertrand-Krajewski, J.-L., 2023. End-user perspective of low-cost sensors for urban stormwater monitoring: a review. *Water Sci. Technol.*, wst2023142. <https://doi.org/10.2166/wst.2023.142>.