



HAL
open science

KLR and Schur algebras for curves and semi-cuspidal representations

Ruslan Maksimau, Alexandre Minets

► **To cite this version:**

Ruslan Maksimau, Alexandre Minets. KLR and Schur algebras for curves and semi-cuspidal representations. *International Mathematics Research Notices*, 2023, 2023 (8), pp.6976-7052. 10.1093/imrn/rnac055 . hal-04843133

HAL Id: hal-04843133

<https://hal.science/hal-04843133v1>

Submitted on 17 Dec 2024

HAL is a multi-disciplinary open access archive for the deposit and dissemination of scientific research documents, whether they are published or not. The documents may come from teaching and research institutions in France or abroad, or from public or private research centers.

L'archive ouverte pluridisciplinaire **HAL**, est destinée au dépôt et à la diffusion de documents scientifiques de niveau recherche, publiés ou non, émanant des établissements d'enseignement et de recherche français ou étrangers, des laboratoires publics ou privés.

KLR AND SCHUR ALGEBRAS FOR CURVES AND SEMI-CUSPIDAL REPRESENTATIONS

RUSLAN MAKSIMAU AND ALEXANDRE MINETS

ABSTRACT. Given a smooth curve C , we define and study analogues of KLR algebras and quiver Schur algebras, where quiver representations are replaced by torsion sheaves on C . In particular, they provide a geometric realization for certain affinized symmetric algebras. When $C = \mathbb{P}^1$, a version of curve Schur algebra turns out to be Morita equivalent to the imaginary semi-cuspidal category of the Kronecker quiver in any characteristic. As a consequence, we argue that one should not expect to have a reasonable theory of parity sheaves for affine quivers.

CONTENTS

0. Introduction	1
1. Localization of convolution algebras	3
2. Torsion sheaves on curves	7
3. Schur algebra of a smooth curve	11
4. KLR algebra of a smooth curve	19
5. Integral version for \mathbb{P}^1	22
6. KLR algebras of quivers	25
7. Semi-cuspidal category of the Kronecker quiver	30
Appendix A. Several parity questions	41
References	43

0. INTRODUCTION

0.1. Motivation. KLR algebras were introduced by Khovanov and Lauda [KL09] and Rouquier [Rou08] as a tool for categorification of quantum groups. The geometric construction of this algebras was given by Varagnolo and Vasserot [VV11] and Rouquier [Rou12]. The positive characteristic version of this construction was done in [Mak15].

Let us recall this geometric construction. Let Γ be a quiver without loops and let α be the dimension vector. To this data we can associate a complex variety Z_α . Its points are parameterized by triples, consisting of a representation of Γ having dimension α together with two full flags of subrepresentations on it. Then the algebra $R(\alpha)$ is isomorphic to the equivariant Borel-Moore homology $H_*^{G_\alpha}(Z_\alpha)$, where G_α is a certain group of gauge transformations. The union of categories of (graded, projective, finitely generated) $R(\alpha)$ -modules can be then equipped with induction and restriction functors. These functors categorify product and coproduct in the quantum group $U_q^-(\mathfrak{g}_\Gamma)$, where \mathfrak{g}_Γ is the Kac-Moody Lie algebra associated to Γ .

One of our motivations was to generalize this construction to other objects. Namely, recall that by a theorem of Ringel-Green [Rin90, Gre95] the quantum group $U_q^-(\mathfrak{g}_\Gamma)$ can be also realized as the spherical Hall algebra of the category of representations of Γ . Another class of categories whose Hall algebras were actively considered is categories $\text{Coh } C$ of coherent sheaves over smooth curves, see [Sch12] for an overview. In particular, starting with an elliptic curve, we get the elliptic Hall algebra, which was extensively studied under many different guises [MS17, BS12, Neg14, SV13]. Proceeding by analogy with quivers, we expect that KLR-like algebras associated to the category $\text{Coh } C$ will provide an interesting categorification of the Hall algebra of C .

Date: December 16, 2024.

2010 Mathematics Subject Classification. Primary 20G43, secondary 14D23, 20C08.

In the present paper, we are making first steps in this direction. Namely, given a smooth curve C we consider the moduli stack $\mathcal{T}_C = \text{Tor } C$, which parameterizes torsion sheaves on C . Repeating the construction of KLR algebras, we consider the moduli of triples, consisting of a torsion sheaf of length n together with two full flags of subsheaves. Its Borel-Moore homology gets equipped with a convolution product, and we call the resulting algebra \mathcal{R}_n^C the *curve KLR algebra*.¹ Further, replacing full flags by partial flags, we define and study the *curve Schur algebras* \mathcal{S}_n^C . We obtain the following explicit description of \mathcal{S}_n^C , see Section 2 for notations.

Theorem A (Theorem 3.15). *Let $P_n = \bigoplus_{\lambda \in \text{Comp}(n)} \mathbf{P}_n^{\mathfrak{S}_\lambda}$. The algebra \mathcal{S}_n^C can be identified with the subalgebra of $\text{End}(P_n)$, generated by multiplication operators $P_n \subset \text{End}(P_n)$, inclusions of invariants $\mathcal{S}_\lambda^{\lambda'} : \mathbf{P}_n^{\mathfrak{S}_\lambda} \hookrightarrow \mathbf{P}_n^{\mathfrak{S}_{\lambda'}}$ (split), and the merge operators*

$$M_{\lambda'}^\lambda : \mathbf{P}_n^{\mathfrak{S}_{\lambda'}} \rightarrow \mathbf{P}_n^{\mathfrak{S}_\lambda}, \quad M_{\lambda'}^\lambda(P) = \sum_{a \in \mathfrak{S}_\lambda / \mathfrak{S}_{\lambda'}} \left(y \prod_{i=1}^{\lambda_k} \prod_{j=1}^{\lambda_{k+1}} \left(1 + \frac{\Delta_{\tilde{\lambda}_{k-1+i}, \tilde{\lambda}_{k+j}}}{x_{\tilde{\lambda}_{k+j}} - x_{\tilde{\lambda}_{k-1+i}}} \right) \right)^a,$$

where $\lambda' = (\lambda_1, \dots, \lambda_r)$ is a composition of n , $\tilde{\lambda}_k = \sum_{1 \leq i \leq k} \lambda_i$, and $\lambda = (\lambda_1, \dots, \lambda_{k-1}, \lambda_k + \lambda_{k+1}, \lambda_{k+2}, \dots, \lambda_r)$.

We also provide an explicit basis and a diagrammatic presentation for \mathcal{S}_n^C , see Theorem 3.10. It turns out that the integral version of \mathcal{S}_n^C for $C = \mathbb{P}^1$ is intimately related to the representation theory of KLR algebras in type $\widehat{\mathfrak{sl}}_2$.

0.2. Semi-cuspidal categories. Let Γ be a quiver of affine type. It is known [McN17b, KM17b] (under some conditions on the characteristic of the base field) that the KLR algebra $R(\alpha)$ is properly stratified, see [Kle15] for the definition of this property. Informally speaking, this means that one can slice the category of $R(\alpha)$ -modules into a collection of categories $C(n\xi)\text{-mod}$, where ξ is a positive root. The category $C(n\xi)\text{-mod}$ is the category of semi-cuspidal $R(n\xi)$ -modules. It is easy to describe if ξ is a real root, but becomes much more complicated when $\xi = \delta$ is the imaginary root. In the present paper, we shed some light on this problem by finding an explicit diagrammatic algebra, which is Morita equivalent to $C(n\delta)$ in any characteristic.

When working over \mathbb{k} a field of characteristic zero, this was already done in [KM19]. In this case $C(n\delta)$ can be shown to be Morita equivalent to $e_0 C(n\delta) e_0$ for some simple and explicit idempotent e_0 . For any $\mathbb{Z}_{\geq 0}$ -graded symmetric algebra F , Kleshchev and Muth introduce the affinized symmetric algebra $\mathfrak{W}_n(F)$ of rank n , and then prove an isomorphism $e_0 C(n\delta) e_0 \simeq \mathfrak{W}_n(F)$ for a specific choice of F . In particular, in type $\widehat{\mathfrak{sl}}_2$ one has $F = \mathbb{k}[c]/(c^2)$.

In positive characteristic, the algebras $C(n\delta)$ and $e_0 C(n\delta) e_0$ are not Morita equivalent any more. It is possible to find a more complicated idempotent e such that the algebras $C(n\delta)$ and $eC(n\delta)e$ are Morita equivalent. However, no explicit description of $eC(n\delta)e$ is known in general.

The starting point of our contribution is the following observation:

Theorem B (Theorem 4.15, Section 5.3). *We have an isomorphism of algebras $\mathcal{R}_n^C \simeq \mathfrak{W}_n(H^*(C, \mathbb{Q}))$. When $C = \mathbb{P}^1$, this isomorphism holds over any field \mathbb{k} .*

This suggests that the curve Schur algebras \mathcal{S}_n^C can be related to the imaginary semi-cuspidal categories. Indeed, let Γ be the Kronecker quiver, and $C = \mathbb{P}^1$. Using the well-known derived equivalence between coherent sheaves on \mathbb{P}^1 and representations of Γ , we produce a homomorphism $\Phi_n : eC(n\delta)e \rightarrow \mathcal{S}_n^{\mathbb{P}^1}$. It is constructed in a geometric fashion, and is defined over any field, as well as over $\mathbb{k} = \mathbb{Z}$. It turns out that Φ_n is bijective if \mathbb{k} is a field of characteristic zero and is injective for $\mathbb{k} = \mathbb{Z}$, with the image $\widetilde{\mathcal{S}}_n^{\mathbb{P}^1} := \text{Im } \Phi_n$ being a sublattice of full rank in $\mathcal{S}_n^{\mathbb{P}^1}$. Note that Φ_n is not an isomorphism; this discrepancy is related to the fact that the integral cohomology groups of the stack \mathcal{T}_C are not generated by tautological classes, see Example 5.7 and Proposition 7.37. In conclusion, we get the following result:

Theorem C (Theorem 7.39). *Let Γ be the Kronecker quiver, and let δ be the imaginary simple root. Denote $\widetilde{\mathcal{S}}_n^{\mathbb{F}_p} = \widetilde{\mathcal{S}}_n^{\mathbb{P}^1} \otimes_{\mathbb{Z}} \mathbb{F}_p$. For any $n > 0$ and p prime, we have an isomorphism $eC_{\mathbb{F}_p}(n\delta)e \simeq \widetilde{\mathcal{S}}_n^{\mathbb{F}_p}$.*

¹KLR algebras are often called “quiver Hecke algebras”, so we could call \mathcal{R}_n^C “curve Hecke algebra”. We opted to not use this terminology, since Hecke algebras already appear in too many different contexts

Note that $H^*(\mathbb{P}^1, \mathbb{k}) \simeq \mathbb{k}[c]/(c^2)$, so as a byproduct we obtain a new geometric proof of the isomorphism of Kleshchev-Muth in type $\widehat{\mathfrak{sl}}_2$.

The sublattice $\widetilde{\mathcal{S}}_n^{\mathbb{P}^1}$ can be described in terms of Theorem A. Namely, we give a certain explicit sublattice $\widetilde{P}_n \subset P_n$ which is preserved under the action of $\widetilde{\mathcal{S}}_n^{\mathbb{P}^1}$. The algebra $\widetilde{\mathcal{S}}_n^{\mathbb{P}^1}$ is then generated by multiplication operators in \widetilde{P}_n , together with split and merge operators $S_\lambda^{\lambda'}$, $M_\lambda^{\lambda'}$. This allows us to obtain a diagrammatic description, an explicit basis and a polynomial representation $\widetilde{P}_n \otimes_{\mathbb{Z}} \mathbb{F}_p$ for $\widetilde{\mathcal{S}}_n^{\mathbb{F}_p}$. We conjecture that this representation is faithful, see Conjecture 7.40.

In Appendix A we discuss a consequence of the fact that the map Φ_n is not surjective over \mathbb{F}_p . We show that for the Kronecker quiver the fibers of the flag version of Springer resolution have even cohomology groups over \mathbb{Z} . For a quiver of Dynkin type, this would be enough to exhibit a nice theory of parity sheaves on the quiver variety [Mak15]. However, the existence of such a theory for the Kronecker quiver would imply surjectivity of Φ_n .

0.3. Future work. We expect that applying our approach to curves with orbifold points will shed light on the semi-cuspidal category $C(n\delta)\text{-mod}$ in other types. It would be also interesting to deduce some combinatorics of $C(n\delta)\text{-mod}$ from our explicit description of $eC(n\delta)e$.

Concerning the categorification questions, the next logical steps would be to consider Schur algebras for the whole category $\text{Coh } C$, including sheaves of positive rank. We plan to investigate this in the future. For $C = \mathbb{P}^1$, partial results in this direction were obtained in [SVV19]. For $C = E$ an elliptic curve, we hope to obtain a categorification of the elliptic Hall algebra, compatible with the action of the braid group B_3 on $D^b(\text{Coh } E)$.

0.4. Organization of paper. We start by recalling the theory of convolution algebras and their localization in Section 1. Next, we introduce the moduli stack of (flags of) torsion sheaves on a smooth curve and prove some of its properties in Section 2. In Section 3 we introduce curve Schur algebras \mathcal{S}_n^C , and construct a basis and a faithful representation for them. A certain simple subalgebra of \mathcal{S}_n^C is described by generators and relations in Section 4. In Section 5, we discuss in detail the integral version of \mathcal{S}_n^C for $C = \mathbb{P}^1$. In Section 6, we recall some properties of KLR algebras and their divided power version. In Section 7, we provide a description of the semi-cuspidal category of the Kronecker quiver in positive characteristic in terms of \mathcal{S}_n^C . Finally, these results are used in Appendix A to show that there is no satisfactory theory of parity sheaves for the Kronecker quiver.

Acknowledgments. A crucial role in the development of this paper was played by Alexander Kleshchev. We thank him for numerous fruitful discussions, for sharing his insight into semi-cuspidal representations of KLR algebras and particularly for pointing out to us that the map Φ_n should not be surjective over \mathbb{Z} . The authors would also like to thank Anton Mellit, Olivier Schiffmann, Éric Vasserot for stimulating discussions, and anonymous referees for valuable feedback. This collaboration between the two authors started from a conversation at the workshop “Geometric representation theory and low-dimensional topology” at ICMS, Edinburgh, and was in parts conducted during the thematic trimester on representation theory at IHP, Paris.

Notations. All varieties we consider are defined over \mathbb{C} , and $\dim(-)$ always means the complex dimension. The coefficient ring of H_* is denoted by \mathbb{k} . We always assume either that \mathbb{k} is a field, or $\mathbb{k} = \mathbb{Z}$. In Sections 3 and 4 we additionally assume that \mathbb{k} is a field of characteristic zero. We will almost always drop the coefficient ring from the notation.

For any G -variety X we define $H_G^*(X) := H_{2\dim X - *}^G(X)$ by abuse of notation. When X is smooth, we recover the usual cohomology groups, while for general X this is usually not true. We introduce this notation solely for the purpose of getting correct gradings later on, and will avoid it whenever possible. We will *never* consider usual cohomology groups for singular varieties.

1. LOCALIZATION OF CONVOLUTION ALGEBRAS

1.1. Borel-Moore homology and refined pullbacks. Recall that for an algebraic variety X , its Borel-Moore homology is defined as relative homology with respect to some compactification of X . In what follows, we will drop the superscript and write $H_*(X) = H_*^{BM}(X)$. For any proper map $f : X \rightarrow Y$, we

have the direct image $f_* : H_*(X) \rightarrow H_*(Y)$. For any lci² morphism $g : X \rightarrow Y$, we have the pullback map $g^* : H_*(Y) \rightarrow H_{*+2d}(X)$, where d is the relative dimension of g . Further, let $h : Y' \rightarrow Y$ be an arbitrary morphism. Form a cartesian square

$$(1) \quad \begin{array}{ccc} Y' \times_Y X & \xrightarrow{g'} & Y' \\ \downarrow h' & & \downarrow h \\ X & \xrightarrow{g} & Y \end{array}$$

Then one can define the *refined pullback* $(g')_g^! : H_*(Y') \rightarrow H_{*+2d}(Y' \times_Y X)$. In particular, if $X, Y' \subset Y$ are closed subvarieties, and both X and Y are smooth, we get a restriction map $H_*(Y') \rightarrow H_{*-2\text{codim}_Y X}(Y' \cap X)$.

Remark 1.1. As notation suggests, $(g')_g^!$ depends on the whole cartesian square (1), and not just the map g' . However, we will often drop the subscript, when the choice of cartesian square is clear.

For a closed embedding of smooth varieties $X \subset Y$, we denote its normal bundle by $N_X Y$. We say that a diagram is a fiber diagram if all squares in it are cartesian.

Proposition 1.2. (a) For any fiber diagram

$$\begin{array}{ccccc} Y' \times_Y X_2 & \xrightarrow{g'_2} & Y' \times_Y X_1 & \xrightarrow{g'_1} & Y' \\ \downarrow & & \downarrow & & \downarrow \\ X_2 & \xrightarrow{g_2} & X_1 & \xrightarrow{g_1} & Y \end{array}$$

we have $(g'_1 \circ g'_2)_{g'_1 \circ g'_2}^! = (g'_2)_{g_2}^! \circ (g'_1)_{g_1}^!$, provided that g_1 and g_2 are lci;

(b) consider a fiber diagram

$$\begin{array}{ccc} X'' & \xrightarrow{g''} & Y'' \\ \downarrow f' & & \downarrow f \\ X' & \xrightarrow{g'} & Y' \\ \downarrow h' & & \downarrow h \\ X & \xrightarrow{g} & Y \end{array}$$

with both g and g' regular embeddings. Then $(g'')_g^! = e(h^*(N_X Y)/N_{X'} Y') \cdot (g'')_{g'}^!$;

(c) consider a fiber diagram as in (b). If f is proper, then $(g'')_g^! \circ f_* = f'_* \circ (g'')_{g'}^!$;

(d) consider a fiber diagram

$$\begin{array}{ccccc} X'' & \xrightarrow{g''} & Y'' & \longrightarrow & Z' \\ \downarrow h'' & & \downarrow h' & & \downarrow h \\ X' & \xrightarrow{g'} & Y' & \longrightarrow & Z \\ \downarrow & & \downarrow & & \\ X & \xrightarrow{g} & Y & & \end{array}$$

with g and h lci morphisms. Then $(g'')_g^! \circ (h')^! = (h'')^! \circ (g')^!$;

(e) suppose g in (1) is a closed embedding. Then $(g')_g^! \circ (g')_*(-) = e((h')^* N_X Y) \cdot -$.

Proof. For (a-d), see [FM81] and [Ful98, Chapter 6]. The part (e) follows by setting $Y'' = X'$ in (c), and further $Y' = Y'' = X'$ in (b). \square

²that is, a composition of a regular embedding and a smooth map

1.2. Localization theorem. Let $T \subset G$ be a reductive group together with a fixed maximal torus, and denote by W the corresponding Weyl group. In this paper, we will be chiefly considering equivariant Borel-Moore homology groups. Proposition 1.2 extends to the equivariant case by the argument in [AHR15, Appendix B.9]. For brevity, we will always denote the G -equivariant cohomology of a point $H_G^*(pt)$ by H_G .

Proposition 1.3 ([Hsi75, III.§1]). *Let X be a G -variety, and \mathbb{k} a field of characteristic 0. Then $H_*^G(X, \mathbb{k}) \simeq H_*^T(X, \mathbb{k})^W$.*

Let X be a T -variety. The homology group $H_*^T(X)$ is naturally an H_T -module; we will write $H_*^T(X)_{\text{loc}}$ for its localization $H_*^T(X) \otimes_{H_T} \text{Frac}(H_T)$.

Let X^T be the subvariety of points in X fixed by T , and the inclusion $i_X : X^T \hookrightarrow X$ the natural embedding.

Proposition 1.4 (Localization theorem). *Let T be an algebraic torus, and X a T -variety. Suppose that X^T is not empty. Then the $\text{Frac}(H_T)$ -linear map $i_{X^*} : H_*^T(X^T)_{\text{loc}} \rightarrow H_*^T(X)_{\text{loc}}$ is an isomorphism. Moreover, assume that \mathbb{k} is a torsion-free \mathbb{Z} -module. Then for any T -equivariant closed embedding $X \hookrightarrow Y$ into a smooth T -variety Y , the map $(i_X)_! : H_*^T(X)_{\text{loc}} \rightarrow H_*^T(X^T)_{\text{loc}}$ is an isomorphism as well.*

Proof. The first claim is proved in [Hsi75, III.§1]. The second claim is obtained by applying Proposition 1.2.(e). \square

Remark 1.5. Note that we only need the assumption on \mathbb{k} to assure that the Euler class in Proposition 1.2.(e) is not a zero divisor. Thus the proposition will hold for other \mathbb{k} , if we can check this condition separately.

Applying Proposition 1.2.(e), we get a useful corollary.

Lemma 1.6. *Let $f : X' \rightarrow Y'$ be a projective morphism of smooth T -varieties, $Y \subset Y'$ is a closed T -stable subvariety, and $X = Y \times_{Y'} X'$. Assume that fixed point sets X^T, Y^T are non-empty, and let $f_T : X^T \rightarrow Y^T$ be the restriction of f . Then we have a base change formula in localized homology groups:*

$$i_Y^! f_*(-) = e(N_{(Y^T)^T} Y^T) \cdot f_{T*} (e(N_{(X^T)^T} X^T)^{-1} \cdot i_X^!(-)).$$

Corollary 1.7. *Let X be a G -variety. Assume that $H_*^G(X)$ is a torsion-free H_G -module. Then the composition*

$$H_*^G(X) \subset H_*^T(X) \rightarrow H_*^T(X)_{\text{loc}} \simeq H_*^T(X^T)_{\text{loc}}$$

is injective.

Proof. It's enough to check that for any $a \in H_*^G(X)$, its annihilator inside the H_T -module $H_*^T(X)$ is trivial. Since $H_*^G(X)$ is torsion free, we have $\text{Ann}(a) \cap H_G = 0$. If $pa = 0$ for $p \in H_T$, then $\prod_{\sigma \in W} \sigma(p)$ lies in the above intersection. Since H_T is integral, we conclude that $p = 0$. \square

Note that for a G -variety X , its homology $H_*^T(X^T)$ acquires a W -action, induced diagonally from the actions on X^T and T . We therefore obtain an embedding $H_*^G(X) \subset (H_*^T(X^T)_{\text{loc}})^W$.

1.3. Convolution algebras. Let $\pi : Y \rightarrow X$ be a proper morphism between smooth varieties. For any $k \geq 1$, define

$$Z^{(k)} = \underbrace{Y \times_X \dots \times_X Y}_{k+1 \text{ terms}}$$

and let $j_k : Z^{(k)} \hookrightarrow Y^{k+1}$ be the natural embedding. We will write $Z = Z^{(1)}$, $Z^{(0)} = Y$, and $j = j_1$.

For any finite set of indices $I = \{i_1 < i_2 < \dots < i_k\}$, where $i_k \leq n$, consider the natural projections $p_I = p_{i_1 \dots i_k} : Y^n \rightarrow Y^k$ onto the coordinates contained in I . We will denote the corresponding restrictions $Z^{(n-1)} \rightarrow Z^{(k-1)}$ by the same letter. In particular, for any $1 \leq i \leq k+1$, we have a map $p_i : Z^{(k)} \rightarrow Y$. Since Y is smooth, the embedding $(p_i, \text{id}_Z) : Z^{(k)} \hookrightarrow Y \times Z^{(k)}$ is regular, so that the pullback along it provides us with an $H^*(Y)$ -module structure on $H_*(Z^{(k)})$. We will denote this action by $\gamma \cdot x$, where $\gamma \in H^*(Y)$, $x \in H_*(Z^{(k)})$.

Consider the following diagram with cartesian square:

$$\begin{array}{ccccc} Z \times Z & \xleftarrow{(p_{12}, p_{23})} & Z^{(2)} & \xrightarrow{p_{13}} & Z \\ \downarrow & & \downarrow & & \\ Y^2 \times Y^2 & \xleftarrow{\quad} & Y^3 & & \end{array}$$

For each $\gamma \in H^*(Y)$, we have the following convolution product on $H_*(Z)$:

$$\begin{aligned} *_{\gamma} : H_*(Z) \otimes H_*(Z) &\rightarrow H_{*-2 \dim Y - \deg \gamma}(Z), \\ a \otimes b &\mapsto (p_{13})_* (\gamma \cdot_2 (p_{12}, p_{23})^! (a \otimes b)), \end{aligned}$$

where the refined pullback $(p_{12}, p_{23})^!$ is defined with respect to the regular embedding $Y^3 \hookrightarrow Y^2 \times Y^2$. In the same fashion, we have a map

$$(2) \quad \begin{aligned} H_*(Z) \otimes H_*(Y) &\rightarrow H_{* - \deg \gamma}(Y), \\ a \otimes x &\mapsto (p_1)_* ((\gamma x) \cdot_2 a). \end{aligned}$$

Proposition 1.8. $\mathcal{A}_{\gamma} = \mathcal{A}_{\gamma}(\pi) = (H_*(Z), *_{\gamma})$ is an associative algebra. The map (2) defines an \mathcal{A}_{γ} -module structure on $H_*(Y)$.

Proof. For $\gamma = 1 \in H^0(Y)$ this is Corollary 2.7.41, 2.7.42 in [CG10]. For general γ , the proof is analogous. \square

Notation. In what follows, we will call γ the *twist*, and drop the subscript if $\gamma = 1 \in H^0(Y)$.

Example 1.9. Consider the identity map $Y \rightarrow Y$. The associated convolution algebra is simply $H_*(Y)$ together with intersection product. Moreover, the closed embedding $Y \simeq Y \times_Y Y \hookrightarrow Y \times_X Y = Z$ defines a homomorphism of algebras $H_*(Y) \rightarrow \mathcal{A}$, and restriction of the action in Proposition 1.8 to $H_*(Y)$ coincides with the left action of $H_*(Y)$ on itself.

Suppose now that T is an algebraic torus, X and Y are T -varieties, and π is T -equivariant. Note that $Z^T = Y^T \times_{X^T} Y^T$. Let us further assume that $\pi_{Y^T} : Y^T \rightarrow X^T$ is a submersion, so that $Z^{(k)T}$ is smooth for any $k \geq 1$. Therefore, Proposition 1.8 produces algebra structures on $H_*^T(Z)$ and $H_*^T(Z^T)_{\text{loc}}$. Let us call these algebras \mathcal{A} and \mathcal{A}^T respectively, where subscripts stand for the twist.

Let $e(Y) \in H_T^*(Y^T)$ denote the equivariant Euler class of the normal bundle $N_{Y^T Y}$.

Proposition 1.10. The localization map $i_Z^!$ induces an algebra homomorphism $\mathcal{A} \rightarrow \mathcal{A}_{e(Y)^{-1}}^T$.

Proof. Consider the localization diagram:

$$\begin{array}{ccccc} Z \times Z & \xleftarrow{p_{12} \times p_{23}} & Z^{(2)} & \xrightarrow{p_{13}} & Z \\ i_Z \times i_Z \uparrow & & i_{Z^{(2)}} \uparrow & & i_Z \uparrow \\ Z^T \times Z^T & \xleftarrow{p^T} & Z^{(2)T} & \xrightarrow{q^T} & Z^T \end{array}$$

Note that the left square is cartesian, while the one on the right is only commutative. By Proposition 1.2.(d), we have $(i_{Z^{(2)}}^!)_{i_{Y^4}} \circ (p_{12} \times p_{23})^! = (p^T)_{p_{12} \times p_{23}}^! \circ (i_{Z \times Z})_{i_{Y^4}}^!$. On the other hand, by Lemma 1.6 we have

$$\begin{aligned} i_Z^! p_{13*}(-) &= q_{T*} (e(N_{Y^4 T} Y^4)^{-1} f_T^* (e(N_{Y^2 T} Y^2))) \cdot (i_{Z^{(2)}}^!)_{i_{Y^4}}(-) \\ &= q_{T*} \left(e(Y)^{-2} \cdot_2 (i_{Z^{(2)}}^!)_{i_{Y^4}}(-) \right) \end{aligned}$$

Finally, Proposition 1.2.(b) shows that $(p^T)_{p_{12} \times p_{23}}^! = e(Y) \cdot_2 p_T^*$. Putting everything together, we get

$$\begin{aligned} i_Z^! p_{13*} \circ (p_{12} \circ p_{23})^!(-) &= q_{T*} \left(e(Y)^{-2} \cdot_2 (i_{Z^{(2)}}^!)_{i_{Y^4}} \circ (p_{12} \circ p_{23})^!(-) \right) \\ &= q_{T*} \left(e(Y)^{-2} \cdot_2 (p^T)_{p_{12} \times p_{23}}^! \circ i_{Z^2}^!(-) \right) = q_{T*} \left(e(Y)^{-1} \cdot_2 p_T^* \circ i_{Z^2}^!(-) \right), \end{aligned}$$

which proves that $i_Z^!$ commutes with multiplication. \square

Proposition 1.11. *We have a commutative square*

$$\begin{array}{ccc} \mathcal{A} \otimes H_*(Y) & \longrightarrow & H_*(Y) \\ \downarrow i_Z^* \times i_Y^* & & \downarrow i_Y^* \\ \mathcal{A}_{e(Y)^{-1}}^T \otimes H_*^T(Y^T)_{\text{loc}} & \longrightarrow & H_*^T(Y^T)_{\text{loc}} \end{array}$$

where the horizontal maps are defined by (2).

Proof. Analogous to Proposition 1.10. \square

1.4. Convolution from finite group action. Let us conclude this section with an easy example, which will become useful later. Namely, let Γ be a finite group acting on a smooth variety X , and set $Y = \Gamma \times X$, with $\pi : Y \rightarrow X$ being the projection. We clearly have $Z = \Gamma^2 \times X$, and

$$(3) \quad H_*(Y) \simeq \mathbb{k}[\Gamma] \otimes H_*(X), \quad H_*(Z) \simeq \mathbb{k}[\Gamma]^{\otimes 2} \otimes H_*(X).$$

Fix a class $\gamma \in H^*(X)$, and let $\gamma^\circ = \sum_{g \in \Gamma} g \otimes \gamma^g \in H_*(Y)$, where x^g denotes the image of $x \in H_*(X)$ under the action of $g \in \Gamma$. Consider the algebra $\mathcal{A}_{\gamma^\circ}$. As a vector space, it is isomorphic to $H_*(Z)$, while the product is given by

$$(4) \quad (g_1 \otimes g_2 \otimes x) * (h_1 \otimes h_2 \otimes y) = \delta_{g_2, h_1} (g_1 \otimes h_2 \otimes x y \gamma^{g_2}),$$

where δ_{g_2, h_1} is the Kronecker delta. Note that if we equip $Y = \Gamma \times X$ with the diagonal Γ -action, π becomes Γ -equivariant. Moreover, $\gamma^\circ \in H_*(Y)$ is a Γ -invariant class. Therefore, Γ acts on $\mathcal{A}_{\gamma^\circ}$ via algebra automorphisms; under the isomorphism (3), it gets identified with the diagonal action on $\mathbb{k}[\Gamma]^{\otimes 2} \otimes H_*(X)$. Consider the Γ -invariant subalgebra $\mathcal{A}_{\gamma^\circ}^\Gamma \subset \mathcal{A}_{\gamma^\circ}$. Its basis is given by elements

$$\xi_{(g,x)} = \sum_{h \in \Gamma} h \otimes h g \otimes x^h.$$

Using the formula (4), we get

$$(5) \quad \xi_{(g,x)} * \xi_{(h,y)} = \sum_{f \in \Gamma} f \otimes f g h \otimes x^f (y \gamma)^{f g} = \xi_{(gh, x(y \gamma)^g)}$$

In particular, assume that γ is invertible and of even degree. Denote $\tilde{\xi}_{(g,x)} = \xi_{(g, x \gamma^{-1})}$. Then $\tilde{\xi}_{(g,x)} * \tilde{\xi}_{(h,y)} = \tilde{\xi}_{(gh, x y^g)}$, so that $\mathcal{A}_{\pi^* \gamma}^\Gamma$ is isomorphic to the semi-direct tensor product $H_*(X) \rtimes \mathbb{C}[\Gamma]$.

In the same way, $H_*(Y)^\Gamma$ is an $\mathcal{A}_{\gamma^\circ}^\Gamma$ -module. We have

$$H_*(X) = H_*(Y)^\Gamma \hookrightarrow H_*(Y), \quad x \mapsto x^\circ.$$

Under this identification, the action is given by $\xi_{(g,x)} \cdot y = x (y \gamma)^g$, or equivalently $\tilde{\xi}_{(g,x)} \cdot y = x y^g \frac{\gamma^g}{\gamma}$. Setting $\tilde{\psi}_y = y \gamma^{-1}$, we get $\tilde{\xi}_{(g,x)} \cdot \tilde{\psi}_y = \tilde{\psi}_{x y^g}$.

Remark 1.12. The action map $a : Y = \Gamma \times X \rightarrow X$ is Γ -equivariant, where Γ acts by multiplication on the first coordinate of Y . It is easy to check that the map $Y \rightarrow Y$, $(g, x) \mapsto (g, g \cdot x)$ induces an isomorphism of algebras $\mathcal{A}_{\pi^* \gamma}^\Gamma(a) \simeq \mathcal{A}_{\gamma^\circ}^\Gamma(\pi)$.

2. TORSION SHEAVES ON CURVES

2.1. Flag varieties. In this subsection, we recall some standard facts about flag varieties.

For each n , consider \mathbb{C}^n together with its standard basis e_1, \dots, e_n , and let $V_k = \bigoplus_{i=1}^k \mathbb{C} e_i$ for any $1 \leq k \leq n$. Let $G_n = GL(\mathbb{C}^n)$, \mathfrak{S}_n the symmetric group on n symbols, and let $T_n \subset B_n \subset G_n$ be the maximal torus and the Borel subgroup, associated to the basis above. We call a tuple of positive integers $\lambda = (\lambda_1, \dots, \lambda_k)$ a *composition* of n , if $\sum_i \lambda_i = n$ (the length k is not fixed), and denote by $\text{Comp}(n)$ the set thereof. We also set $\tilde{\lambda}_i = \lambda_1 + \dots + \lambda_i$. We introduce the following index subsets of \mathbb{Z}^2 :

$$N_\lambda = \bigcup_{0 \leq i < j \leq r-1} [\tilde{\lambda}_i + 1, \tilde{\lambda}_{i+1}] \times [\tilde{\lambda}_j + 1, \tilde{\lambda}_{j+1}], \quad I_\lambda = N_\lambda \cup \left(\bigcup_i [\tilde{\lambda}_i + 1, \tilde{\lambda}_{i+1}]^2 \right) \setminus \{(i, i) : 1 \leq i \leq n\}.$$

For each $\lambda \in \text{Comp}(n)$, denote $\mathfrak{S}_\lambda = \mathfrak{S}_{\lambda_1} \times \dots \times \mathfrak{S}_{\lambda_k} \subset \mathfrak{S}_n$, $G_\lambda = G_{\lambda_1} \times \dots \times G_{\lambda_k} \subset G_n$, and $P_\lambda = G_\lambda B_n$. The partial flag variety G_n/P_λ will be denoted by \mathcal{F}_λ ; we will also write $\mathcal{F}_n := \mathcal{F}_{1^n}$ for the complete flag variety.

One can identify $\mathfrak{S}_n/\mathfrak{S}_\lambda$ with the set of minimal length coset representatives, which we denote by \mathfrak{S}^λ :

$$\mathfrak{S}^\lambda = \left\{ \sigma \in \mathfrak{S}_n \mid \sigma(i) < \sigma(j) \text{ if } \tilde{\lambda}_k < i < j \leq \tilde{\lambda}_{k+1} \text{ for some } k \right\}.$$

We have analogous identifications for right and double cosets:

$$\mathfrak{S}_\lambda \backslash \mathfrak{S}_n \simeq {}^\lambda \mathfrak{S} := (\mathfrak{S}^\lambda)^{-1} = \{ \sigma^{-1} \mid \sigma \in \mathfrak{S}^\lambda \}, \quad \mathfrak{S}_\mu \backslash \mathfrak{S}_n / \mathfrak{S}_\lambda \simeq {}^\mu \mathfrak{S}^\lambda := {}^\mu \mathfrak{S} \cap \mathfrak{S}^\lambda.$$

For any $w \in \mathfrak{S}_n$, let $F_w \in \mathcal{F}_\lambda$ be the flag $w.V_{\lambda_1} \subset w.V_{\lambda_1+\lambda_2} \subset \dots \subset \mathbb{C}^n$. Note that F_w depends only on $w\mathfrak{S}_\lambda$. The flags F_w are precisely the T_n -fixed points in \mathcal{F}_λ . Moreover, they are in one-to-one correspondence with left B_n -orbits in \mathcal{F}_λ :

$$\mathcal{F}_\lambda = \bigsqcup_{w \in \mathfrak{S}^\lambda} B_n.F_w.$$

Let us denote $O_w^\lambda = B_n.F_w \subset \mathcal{F}_\lambda$; we will omit the superscript when the choice of parabolic subgroup is clear. Each of these strata is an affine space.

The Bruhat order on \mathfrak{S}_n induces a partial order on \mathfrak{S}^λ . It coincides with the orbit closure order on \mathcal{F}_λ :

$$\forall w_1, w_2 \in \mathfrak{S}^\lambda, \quad [w_1] \leq [w_2] \Leftrightarrow O_{w_1} \subseteq \overline{O_{w_2}}.$$

For any two compositions $\lambda, \mu \in \text{Comp}(n)$, the orbits in $\mathcal{F}_\mu \times \mathcal{F}_\lambda$ with respect to the diagonal action of G_n are parametrized by double cosets. Moreover, we have a G_n -equivariant stratification

$$(6) \quad \mathcal{F}_\mu \times \mathcal{F}_\lambda = \bigsqcup_{w \in {}^\mu \mathfrak{S}^\lambda} \Omega_w$$

where $\Omega_w = G_n.(F_e, F_w)$. For later use, we denote $P_{\mu\lambda}^w := P_\mu \cap w.P_\lambda = \text{Stab}_{G_n}(F_e, F_w)$. It is clear that $P_{\mu\lambda}^w$ retracts to the reductive group $G_{\mu\lambda}^w := G_\mu \cap w.G_\lambda$, whose Weyl group is given by $\mathfrak{S}_\mu \cap w.\mathfrak{S}_\lambda$.

We will write $H_{T_n}^*(pt) = \mathbb{k}[x_1, \dots, x_n]$, where x_i is the first T_n -equivariant Chern class of the line bundle $\mathbb{C}e_i$, equipped with the T_n -linearization by the action of the i -th diagonal element, and $\deg x_i = 2$. We will use x_i and $\mathbb{C}e_i$ interchangeably. In accordance with Proposition 1.3, we have

$$H_{G_n}^*(pt) = \mathbb{k}[x_1, \dots, x_n]^{\mathfrak{S}_n}, \quad H_{G_n}^*(\mathcal{F}_\lambda) = H_{P_\lambda}^*(pt) = \mathbb{k}[x_1, \dots, x_n]^{\mathfrak{S}^\lambda}.$$

The Euler classes of tangent spaces at T_n -fixed points are expressed by the following formulae:

$$e(T_{F_w} \mathcal{F}_\lambda) = \prod_{(i,j) \in wN_\lambda} (x_j - x_i), \quad e(T_{(F_{w_1}, F_{w_2})} G_n.(F_{w_1}, F_{w_2})) = \prod_{(i,j) \in w_1 N_\mu \cup w_2 N_\lambda} (x_j - x_i).$$

2.2. Torsion sheaves on a smooth curve. Let C be a smooth projective curve over \mathbb{C} , and denote by $\mathcal{O} = \mathcal{O}_C$ its structure sheaf. Let $\mathcal{T} = \text{Tor } C$ be the moduli stack of torsion sheaves on C . It has a decomposition into connected components $\mathcal{T} = \bigsqcup_{n \in \mathbb{Z}_{\geq 0}} \mathcal{T}_n$, where \mathcal{T}_n stands for the moduli stack of torsion sheaves of degree n .

The stack \mathcal{T}_n possesses an explicit presentation as a quotient. Namely, let $\text{Quot}_n(\mathbb{C}^n \otimes \mathcal{O})$ be the Quot -scheme for constant Hilbert polynomial $P_\mathcal{E} = n$. Recall (see [LP97] for details) that its \mathbb{C} -points are given by quotients $\varphi : \mathbb{C}^n \otimes \mathcal{O} \rightarrow \mathcal{E}$, where \mathcal{E} is a torsion sheaf of degree n . This Quot -scheme is smooth, and its tangent space at φ is

$$(7) \quad T_\varphi \text{Quot}_n(\mathbb{C}^n \otimes \mathcal{O}) \simeq \text{Hom}(\text{Ker } \varphi, \mathcal{E}).$$

Moreover, the Quot -scheme has a natural G_n -action by automorphisms of $\mathbb{C}^n \otimes \mathcal{O}$. Define Q_n as its open subscheme, consisting of quotients which induce an isomorphism on global sections:

$$Q_n = \{ \varphi : \mathbb{C}^n \otimes \mathcal{O} \rightarrow \mathcal{E} \mid H^0(\varphi) \text{ is an isomorphism} \} \subset \text{Quot}_n(\mathbb{C}^n \otimes \mathcal{O}).$$

Note that Q_n inherits G_n -action.

Lemma 2.1 ([LP97]). *We have an isomorphism of stacks $[Q_n/G_n] \simeq \mathcal{T}_n$.*

In particular, each \mathcal{T}_n is smooth, since the lemma above provides it with a smooth atlas.

When $n = 1$, we have isomorphisms $Quot_1(\mathcal{O}) \simeq Q_1 \simeq C$, and the action of $G_1 \simeq \mathbb{G}_m$ is trivial. In view of this, denote by $p_{ij} : Q_1 \times Q_1 \times C \simeq C \times C \times C \rightarrow C \times C$ the natural projections (as in Section 1.3).

Lemma 2.2 ([Min20, Lemma 3.2]). *Let $\mathcal{K}, \mathcal{E} \in \text{Coh}(Q_1 \times C) \simeq \text{Coh}(C \times C)$ be the universal families of kernels and images of quotients $\mathcal{O} \rightarrow \mathcal{E}$ respectively. Then*

$$p_{12*} \mathcal{H}om(p_{13}^* \mathcal{K}, p_{23}^* \mathcal{E}) \simeq \frac{x_2}{x_1} \mathcal{O}_{C \times C}(\Delta),$$

where $\Delta \subset C \times C$ is the diagonal.

Notation. When working with Q_1^n , we will write $\mathcal{K}_i = p_{i,n+1}^* \mathcal{K}$, $\mathcal{E}_i = p_{i,n+1}^* \mathcal{E}$, and further denote the sheaf $p_{1\dots n*} \mathcal{H}om(\mathcal{K}_i, \mathcal{E}_j)$ of global sections along C by $\text{Hom}(\mathcal{K}_i, \mathcal{E}_j)$.

By [Min20, Lemma 3.1], we have an identification $Q_n^T = (Q_1)^n = C^n$. The normal bundle to the fixed point set $N_{Q_1^n} Q_n$ is given by the following formula:

$$(8) \quad N_{Q_1^n} Q_n = (TQ_n)|_{Q_1^n} / TQ_1^n = \bigoplus_{i \neq j} \text{Hom}(\mathcal{K}_i, \mathcal{E}_j) = \bigoplus_{i \neq j} \frac{x_j}{x_i} \mathcal{O}(\Delta_{ij}),$$

where $\Delta_{ij} \subset C^n$ is the preimage of Δ under the natural projection $p_{ij} : C^n \rightarrow C^2$.

For any $I \subset [1, n]$, write $V_I = \bigoplus_{i \in I} \mathbb{C} e_i$. Let $S \in 2^{[1, n]}$ be a collection of subsets of $[1, n]$. Let $\bar{S} \in 2^{[1, n]}$ be the smallest collection which contains S and is stable under taking intersections and complements. It gives rise to a disjoint union $[1, n] = \bigsqcup_j I_j$, with subsets I_j being subsets in \bar{S} , which are minimal under inclusion. Consider the subset $\tilde{Q}_S \subset Q_n$ consisting of quotients $\varphi : C^n \rightarrow \mathcal{E}$, such that

$$(9) \quad H^0(\varphi)|_{V_I \otimes \mathcal{O}} : V_I \rightarrow H^0(\text{Im } \varphi|_{V_I \otimes \mathcal{O}})$$

is an isomorphism for any $I \in S$. Further, we denote $Q_S := \prod_j Q_{V_j \otimes \mathcal{O}}$, where $Q_{V_j \otimes \mathcal{O}}$ is defined in the same way as $Q_{\dim V_j}$, with $\mathbb{C}^{\dim V_j}$ replaced by V_j .

Lemma 2.3. *\tilde{Q}_S is a smooth closed subvariety of Q_n . More specifically, \tilde{Q}_S is a vector bundle over Q_S .*

Proof. If $S = \{I\}$ consists of one subset, then \tilde{Q}_S is closed in Q_n by [Min20, Proposition 1.8]. For general S , \tilde{Q}_S is closed as an intersection of closed subvarieties.

Let $I \subset [1, n]$, and J its complement. Consider an action of \mathbb{C}^* on C^n , which has weight 1 on V_I and is trivial on V_J . This induces an action a_I of \mathbb{C}^* on Q_n . Moreover, analogously to [Min20, Lemma 3.1] we have $(Q_n)^{\mathbb{C}^*} = Q_{V_I \otimes \mathcal{O}} \times Q_{V_J \otimes \mathcal{O}}$, and the corresponding attracting set is $\tilde{Q}_{\{I\}}$.

For a general S , consider an action of the torus $T_S = \prod_{I \in S} (\mathbb{G}_m)_I$ on Q_n , where for each I the action of $(\mathbb{G}_m)_I$ is given by a_I . Taking intersections, we see that the fixed point set of this action is Q_S , and the attracting set is \tilde{Q}_S . Białyński-Birula's theorem [Bia73] then implies that \tilde{Q}_S is a Zariski locally trivial fibration over Q_S , whose fiber is an affine space. In particular, it is smooth. \square

Let $\lambda = (\lambda_1, \dots, \lambda_k)$ be a composition of n . Consider the stack of flags of torsion sheaves of type λ :

$$\mathcal{F}_\lambda = \{0 = \mathcal{E}_0 \subset \mathcal{E}_1 \subset \dots \subset \mathcal{E}_k : \deg(\mathcal{E}_i / \mathcal{E}_{i-1}) = \lambda_i\}.$$

Analogously to Lemma 2.1, the stack \mathcal{F}_λ has a quotient presentation $\mathcal{F}_\lambda \simeq [\tilde{Q}_\lambda / P_\lambda]$. Here, $\tilde{Q}_\lambda = \tilde{Q}_S$ for $S = \{[1, \tilde{\lambda}_i]\}_{i=1}^k$; we will also call this collection of intervals λ by abuse of notation. Analogously to (8), we have

$$(10) \quad N_{Q_1^n} \tilde{Q}_\lambda = (T\tilde{Q}_\lambda)|_{Q_1^n} / TQ_1^n = \bigoplus_{\substack{(i,j) \in [1,n]^2 \setminus N_\lambda \\ i \neq j}} \text{Hom}(\mathcal{K}_i, \mathcal{E}_j) = \bigoplus_{(i,j) \in I_\lambda} \frac{x_i}{x_j} \mathcal{O}(\Delta_{ij}).$$

We have maps

$$\begin{array}{ccc} & \mathcal{F}_\lambda & \\ q_\lambda \swarrow & & \searrow p_\lambda \\ \mathcal{T}_\lambda & & \mathcal{T}_d \end{array} \quad \begin{aligned} q_\lambda(\mathcal{E}_1 \subset \mathcal{E}_2 \subset \dots \subset \mathcal{E}_k) &= (\mathcal{E}_1, \mathcal{E}_2 / \mathcal{E}_1, \dots, \mathcal{E}_k / \mathcal{E}_{k-1}), \\ p_\lambda(\mathcal{E}_1 \subset \mathcal{E}_2 \subset \dots \subset \mathcal{E}_k) &= \mathcal{E}_k, \end{aligned}$$

where $\mathcal{T}_\lambda := \mathcal{T}_{\lambda_1} \times \dots \times \mathcal{T}_{\lambda_k}$. Note that the map q_λ is not representable, since it is not faithful on automorphism groups of points. However, it is a stack vector bundle, that is it comes from a two-term complex of vector bundles on the base, see [GPHS14, Corollary 3.2]. For instance, when $k = 2$, this complex is $R\mathrm{Hom}_C(\mathcal{E}_1, \mathcal{E}_2)[1]$, where \mathcal{E}_i is the universal sheaf on $\mathcal{T}_{\lambda_i} \times C$. In particular, pulling back along q_λ induces an isomorphism $H^*(\mathcal{F}_\lambda) \simeq H^*(\mathcal{T}_\lambda)$.

On the other hand, p_λ is induced by the embedding $\tilde{Q}_\lambda \hookrightarrow Q_n$:

$$p_\lambda : \mathcal{F}_\lambda \simeq [\tilde{Q}_\lambda/P_\lambda] \simeq [G_n \times_{P_\lambda} \tilde{Q}_\lambda/G_n] \rightarrow [Q_n/G_n] \simeq \mathcal{T}_n.$$

In particular, it is a projective morphism.

Denote $Y_\lambda = G_n \times_{P_\lambda} \tilde{Q}_\lambda$. Then $(Y_\lambda)^{T_n} = \mathfrak{S}_n/\mathfrak{S}_\lambda \times C^n$, and the projection $(Y_\lambda)^{T_n} \rightarrow Q_n^{T_n}$ gets identified with the projection $\mathfrak{S}_n/\mathfrak{S}_\lambda \times C^n \rightarrow C^n$.

Let us denote $\mathbf{P}_n = \mathbf{P}_n(C) = H^*(C^n)[x_1, \dots, x_n]$, where $\deg x_i = 2$.

Proposition 2.4 ([Hei12, Theorem 1]). *We have $H^*(\mathcal{T}_n) \simeq \mathbf{P}_n^{\mathfrak{S}_n}$.*

Since q_λ is a stack vector bundle, we also have

$$(11) \quad H^*(\mathcal{F}_\lambda) \simeq H^*(\mathcal{T}_\lambda) \simeq \bigotimes_i \mathbf{P}_{\lambda_i}^{\mathfrak{S}_{\lambda_i}} = \mathbf{P}_n^{\mathfrak{S}_\lambda}.$$

Lemma 2.5. *Let co be the composition $H^*(\mathcal{T}_n) \simeq H_{G_n}^*(Q_n) \hookrightarrow H_{T_n}^*(Q_n) \xrightarrow{i_{Q_n}^*} H_{T_n}^*(C^n) \simeq H^*(\mathcal{T}_1^n)$. Then the following square commutes:*

$$\begin{array}{ccc} H^*(\mathcal{T}_n) & \xrightarrow{\sim} & \mathbf{P}_n^{\mathfrak{S}_n} \\ \downarrow co & & \downarrow \\ H^*(\mathcal{T}_1^n) & \xlongequal{\quad} & \mathbf{P}_n \end{array}$$

Proof. Consider the following diagram, where the vertical arrows are given by restriction to T_n -fixed points, and $a : \mathfrak{S}_n \times C^n \rightarrow C^n$ is the natural action:

$$\begin{array}{ccccccc} H_{G_n}^*(Q_n) & \longrightarrow & H_{G_n}^*(Y_1^n) & \longleftarrow \sim & H_{B_n}^*(\tilde{Q}_1^n) & \xrightarrow{\sim} & H_{T_n}^*(Q_1^n) \\ \downarrow co & & \downarrow & & \downarrow & & \parallel \\ H_{T_n}^*(C^n) & \xrightarrow{a^*} & H_{T_n}^*(\mathfrak{S}_n \times C^n) & \longleftarrow a^* & H_{T_n}^*(C^n) & \xlongequal{\quad} & H_{T_n}^*(C^n) \end{array}$$

All squares above are obviously commutative, except for the second one, which commutes by [Min20, Lemma A.17]. The proof of Proposition 2.4 in [Hei12] shows that the composition of upper horizontal maps coincides with the inclusion $H^*(\mathcal{T}_n) \simeq \mathbf{P}_n^{\mathfrak{S}_n} \subset \mathbf{P}_n$. On the other hand, the lower horizontal row can be replaced with the identity map without breaking commutativity. This concludes the proof. \square

Corollary 2.6. *Let $\lambda \in \mathrm{Comp}(n)$. The following square commutes:*

$$\begin{array}{ccc} H^*(\mathcal{F}_\lambda) & \longleftarrow \sim & H^*(\mathcal{T}_\lambda) \\ \downarrow co & & \downarrow \\ H_{T_n}^*(\mathfrak{S}_n/\mathfrak{S}_\lambda \times C^n) & \longleftarrow a^* & H_{T_n}^*(C^n) \end{array}$$

where $a : \mathfrak{S}_n/\mathfrak{S}_\lambda \times C^n = \mathfrak{S}^\lambda \times C^n \rightarrow C^n$ is the natural action.

Proof. Consider the following diagram:

$$\begin{array}{ccccccc} H_{G_n}^*(Y_\lambda) & \longleftarrow \sim & H_{P_\lambda}^*(\tilde{Q}_\lambda) & \xrightarrow{\sim} & H_{G_\lambda}^*(Q_\lambda) & \xrightarrow{\sim} & \mathbf{P}_n^{\mathfrak{S}_\lambda} \\ \downarrow & & \downarrow & & \downarrow co & & \downarrow \\ H_{T_n}^*(\mathfrak{S}_n/\mathfrak{S}_\lambda \times C^n) & \longleftarrow a^* & H_{T_n}^*(C^n) & \xlongequal{\quad} & H_{T_n}^*(C^n) & \xrightarrow{\sim} & \mathbf{P}_n \end{array}$$

The first square commutes by [Min20, Lemma A.17], and the last one does by Lemma 2.5. We are done. \square

Remark 2.7. Recall that $\mathcal{T}_1^n \simeq C^n \times BT_n$. In particular, its cohomology has pure weight filtration, and therefore so do $H^*(\mathcal{T}_n)$ and $H^*(\mathcal{F}_\lambda)$.

2.3. Steinberg varieties.

Definition 2.8. Let $\lambda, \mu \in \text{Comp}(n)$. The fiber product

$$Z_{\mu,\lambda} := Y_\mu \times_{Q_n} Y_\lambda \subset Y_\mu \times Y_\lambda$$

is called the *partial Steinberg variety* of type (μ, λ) .

For each $\lambda \in \text{Comp}(n)$, there is a natural map

$$Y_\lambda = G_n \times_{P_\lambda} \tilde{Q}_\lambda \rightarrow \mathcal{F}_\lambda = G_n/P_\lambda, \quad (g, q) \mapsto gP_\lambda.$$

Then the ambient variety $Y_\mu \times Y_\lambda$ comes equipped with a projection to the product of partial flag varieties $f_{\mu,\lambda} : Y_\mu \times Y_\lambda \rightarrow \mathcal{F}_\mu \times \mathcal{F}_\lambda$. The stratification (6) induces the following stratification on $Z_{\mu,\lambda}$:

$$Z_{\mu,\lambda} = \bigsqcup_{w \in {}^\mu\mathfrak{S}^\lambda} Z_{\mu,\lambda}^w := \bigsqcup_{w \in {}^\mu\mathfrak{S}^\lambda} f_{\mu,\lambda}^{-1}(\Omega_w).$$

Let us compute the fiber $f^{-1}(F_e, F_w)$. By definition, we have $f^{-1}(F_e, F_w) = \tilde{Q}_\mu \cap w.\tilde{Q}_\lambda \subset Q_n$, where elements of \mathfrak{S}_d are identified with permutation matrices in G_n . This subvariety is smooth by Lemma 2.3; therefore, each stratum $Z_{\mu,\lambda}^w$ is smooth as well.

Lemma 2.9. Let \mathbb{k} be a field of characteristic 0. The homology groups $H_*^{G_n}(Z_{\mu,\lambda}, \mathbb{k})$ are torsion-free as H_{G_n} -modules.

Proof. Without loss of generality, we can assume that $\mathbb{k} = \mathbb{Q}$. For each stratum $Z_{\mu,\lambda}^w$, we have

$$H_*^{G_n}(Z_{\mu,\lambda}^w) = H_*^{G_n} \left(G_n \times_{P_{\mu\lambda}^w} (\tilde{Q}_\mu \cap w.\tilde{Q}_\lambda) \right) = H_*^{P_{\mu\lambda}^w} (\tilde{Q}_\mu \cap w.\tilde{Q}_\lambda) = H_*^{G_{\mu\cup w,\lambda}}(Q_{\mu\cup w,\lambda}) = H_*(\mathcal{T}_{\mu\cup w,\lambda}).$$

Here, we have used Lemma 2.3. The homology $H_*(\mathcal{T}_S)$ sits inside \mathbf{P}_n by Proposition 2.4, and is therefore a torsion-free H_{G_n} -module. Moreover, it has pure weight filtration by Remark 2.7.

Let us choose a total order $<$ on ${}^\mu\mathfrak{S}^\lambda$ compatible with the orbit closure order, and define

$$Z_{\mu,\lambda}^{<w} = \bigsqcup_{w' < w} Z_{\mu,\lambda}^{w'}, \quad Z_{\mu,\lambda}^{\leq w} = Z_{\mu,\lambda}^{<w} \sqcup Z_{\mu,\lambda}^w.$$

Since each stratum $Z_{\mu,\lambda}^w$ has pure Borel-Moore homology, the associated open-closed long exact sequences split into short exact sequences:

$$0 \rightarrow H_*^{G_n}(Z_{\mu,\lambda}^{<w}) \rightarrow H_*^{G_n}(Z_{\mu,\lambda}^{\leq w}) \rightarrow H_*^{G_n}(Z_{\mu,\lambda}^w) \rightarrow 0,$$

see e.g. [Min20, Lemma 4.9]. In particular, $H_*^{G_n}(Z_{\mu,\lambda})$ has a filtration with associated graded $\bigoplus_w H_*^{G_n}(Z_{\mu,\lambda}^w)$. Since $H_*^{G_n}(Z_{\mu,\lambda}^w)$ is a torsion-free H_{G_n} -module for all w , the same holds for $H_*^{G_n}(Z_{\mu,\lambda})$. \square

3. SCHUR ALGEBRA OF A SMOOTH CURVE

In this section, as well as Section 4, we assume that \mathbb{k} is a field of characteristic 0.

3.1. Schur algebras of curves. Let $Y_n = \bigsqcup_{\lambda \in \text{Comp}(n)} Y_\lambda$, and consider the projection $\pi : Y_n \rightarrow Q_n$. Denote $Z_n = Y_n \times_{Q_n} Y_n$; we have a decomposition into connected components $Z_n = \bigsqcup_{\mu,\lambda} Z_{\mu,\lambda}$. Let us apply the general construction from Section 1 to π .

Definition 3.1. The (torsion) Schur algebra of C , denoted by $\mathcal{S}_n = \mathcal{S}_n^C$, is the convolution algebra $\mathcal{A}(\pi) = H_{G_n}^*(Z_n)$.

One can easily check that the map π is small, so that $\dim Z_{\mu,\lambda} = \dim Y_\lambda = \dim Q_n = n^2$ for any λ, μ . Thanks to our conventions in Section 2.1, \mathcal{S}_n^C is a graded algebra.

Remark 3.2. Since we're only concerned with torsion sheaves in this article, we will omit the qualifier "torsion" from now on. We still mention it in the definition, because one would like to eventually consider a similar algebra for coherent sheaves of positive rank.

We denote $\mathcal{S}_{\mu,\lambda} = H_{G_n}^*(Z_{\mu,\lambda})$. By definition $\mathcal{S}_n = \bigoplus_{\mu,\lambda} \mathcal{S}_{\mu,\lambda}$, and the product in \mathcal{S}_n decomposes into a direct sum of maps $\mathcal{S}_{\nu,\mu} \otimes \mathcal{S}_{\mu,\lambda} \rightarrow \mathcal{S}_{\nu,\lambda}$. Moreover, \mathcal{S}_n acts on the space

$$(12) \quad P_n = \bigoplus_{\lambda} H_{G_n}^*(Y_\lambda) = \bigoplus_{\lambda} \mathbf{P}_n^{\mathfrak{S}_\lambda}$$

by Proposition 1.8. We call P_n the *polynomial representation* of \mathcal{S}_n . This action decomposes into a direct sum of maps $\mathcal{S}_{\mu,\lambda} \otimes H_{G_n}^*(Y_\lambda) \rightarrow H_{G_n}^*(Y_\mu)$.

3.2. Localized Schur algebra. Let us apply equivariant localization to the algebra \mathcal{S}_n . Under the identifications in Section 2, the restriction of π to T_n -fixed points $(Y_\lambda)^{T_n} \rightarrow (Q_n)^{T_n}$ equals to the projection $\mathfrak{S}_n/\mathfrak{S}_\lambda \times C^n \rightarrow C^n$; denote it π_T . Let us also denote by $a_\lambda : \mathfrak{S}_n/\mathfrak{S}_\lambda \times C^n = \mathfrak{S}^\lambda \times C^n \rightarrow C^n$ the natural map induced by action. We also have

$$(Z_n)^{T_n} = \bigsqcup_{\mu,\lambda} (Z_{\mu,\lambda})^{T_n} = \bigsqcup_{\mu,\lambda} \mathfrak{S}_n/\mathfrak{S}_\mu \times \mathfrak{S}_n/\mathfrak{S}_\lambda \times C^n.$$

For each connected component of $(Y_\lambda)^{T_n}$, its normal bundle splits into the direct sum of $N_{C^n} \tilde{Q}_\lambda$ and the tangent space to \mathcal{F}_λ . We identify $(Y_\lambda)^{T_n} \simeq \prod_{w \in \mathfrak{S}_n/\mathfrak{S}_\lambda} \{w\} \times C^n$ as above. Denote by $\gamma_\lambda \in H_{T_n}^*(C^n)$ the Euler class of the normal bundle to $\{\text{Id}\} \times C^n \subset Y_\lambda$.

The formula (10) implies that $e(N_{C^n} \tilde{Q}_\lambda) = \prod_{(i,j) \in I_\lambda} (x_i - x_j + \Delta_{ij})$. Therefore,

$$(13) \quad \gamma_\lambda = e(N_{C^n} \tilde{Q}_\lambda) e(T_{\text{Fid}} \mathcal{F}_\lambda) = \prod_{(i,j) \in I_\lambda} (x_i - x_j + \Delta_{ij}) \prod_{(i,j) \in N_\lambda} (x_j - x_i).$$

Proposition 1.10 provides us with an algebra homomorphism

$$\Xi_n : \mathcal{S}_n \rightarrow (\mathcal{A}_{\gamma^{-1}}^{T_n})^{\mathfrak{S}_n} =: \mathcal{S}_n^{\text{loc}},$$

where $\gamma = \bigoplus_{\lambda} a_\lambda^*(\gamma_\lambda)$. Furthermore, Ξ_n is injective by Lemma 2.9. As a vector space, $\mathcal{S}_n^{\text{loc}}$ is isomorphic to

$$\mathcal{S}_n^{\text{loc}} = \bigoplus_{\mu,\lambda} \mathcal{S}_{\mu,\lambda}^{\text{loc}} = \bigoplus_{\mu,\lambda} (\mathbb{k}[\mathfrak{S}_n/\mathfrak{S}_\mu] \otimes \mathbb{k}[\mathfrak{S}_n/\mathfrak{S}_\lambda] \otimes (H^*(C^n)[x_1, \dots, x_n])_{\text{loc}})^{\mathfrak{S}_n}.$$

Let us describe the multiplication in $\mathcal{S}_n^{\text{loc}}$ explicitly. Pulling back along the quotient map $r_{\mu\lambda} : \mathfrak{S}_n^2 \rightarrow \mathfrak{S}_n/\mathfrak{S}_\mu \times \mathfrak{S}_n/\mathfrak{S}_\lambda$, we obtain the natural inclusion

$$(14) \quad \mathcal{S}_{\mu,\lambda}^{\text{loc}} \subset (\mathbb{k}[\mathfrak{S}_n]^{\otimes 2} \otimes (H^*(C^n)[x_1, \dots, x_n])_{\text{loc}})^{\mathfrak{S}_n}.$$

We use the notations from Section 1.4 with $X = C^n$ and $\Gamma = \mathfrak{S}_n$ for the right-hand side. The image of the inclusion above can be obtained by partial symmetrization. Namely, for any $g \in \mathfrak{S}_n$ consider the element $(\mathfrak{S}_\mu, g\mathfrak{S}_\lambda) \in \mathfrak{S}_n/\mathfrak{S}_\mu \times \mathfrak{S}_n/\mathfrak{S}_\lambda$. Denote its stabilizer under the diagonal \mathfrak{S}_n -action by $\Gamma_g^{\mu\lambda} := \mathfrak{S}_\mu \cap g\mathfrak{S}_\lambda g^{-1}$. Note that $\Gamma_g^{\mu\lambda} \simeq \mathfrak{S}_\nu$ for some $\nu \in \text{Comp}(n)$, and depends only on the image of g in $\mathfrak{S}_\mu \backslash \mathfrak{S}_n/\mathfrak{S}_\lambda$. We have an inclusion $\Gamma_g^{\mu\lambda} \hookrightarrow \mathfrak{S}_\mu \times \mathfrak{S}_\lambda$, which sends f to $(f, g^{-1}fg)$.

The algebra $\mathcal{S}_{\mu,\lambda}^{\text{loc}}$ is spanned by the elements

$$\xi_{(g,x)}^{\mu\lambda} = \sum_{h \in \mathfrak{S}_n/\Gamma_g^{\mu\lambda}} h\mathfrak{S}_\mu \otimes hg\mathfrak{S}_\lambda \otimes x^h,$$

where $g \in \mathfrak{S}_n$ and $x \in (H^*(C^n)[x_1, \dots, x_n])_{\text{loc}}^{\Gamma_g^{\mu\lambda}}$. Moreover, it is clear that $\xi_{(gg',x)}^{\mu\lambda} = \xi_{(g,x)}^{\mu\lambda}$ for $g' \in \mathfrak{S}_\lambda$ and $\xi_{(g'g,xg')}^{\mu\lambda} = \xi_{(g,x)}^{\mu\lambda}$ for $g' \in \mathfrak{S}_\mu$. Thus it is enough to consider $\xi_{(g,x)}^{\mu\lambda}$ with $g \in {}^\mu\mathfrak{S}^\lambda$. Let us compute its image under the inclusion (14):

$$\begin{aligned} \xi_{(g,x)}^{\mu\lambda} &= \sum_{h \in \mathfrak{S}_n/\Gamma_g^{\mu\lambda}} h\mathfrak{S}_\mu \otimes hg\mathfrak{S}_\lambda \otimes x^h \mapsto \frac{1}{|\Gamma_g^{\mu\lambda}|} \sum_{(h_1, h_2) \in \mathfrak{S}_n \times \mathfrak{S}_\mu \times \mathfrak{S}_\lambda} hh_1 \otimes hgh_2 \otimes x^h \\ &= \frac{1}{|\Gamma_g^{\mu\lambda}|} \sum_{(h_1, h_2) \in \mathfrak{S}_\mu \times \mathfrak{S}_\lambda} \xi_{(h_1^{-1}gh_2, x^{h_1^{-1}})} = \sum_{(h_1, h_2) \in (\mathfrak{S}_\mu \times \mathfrak{S}_\lambda)/\Gamma_g^{\mu\lambda}} \xi_{(h_1gh_2, x^{h_1})}. \end{aligned}$$

In what follows, we will abuse the notations and identify $\xi_{(g,x)}^{\lambda\mu}$ with its image under (14).

Consider the following commutative diagram:

$$\begin{array}{ccc} \mathfrak{S}_n^2 \times \mathfrak{S}_n^2 & \xleftarrow{p} & \mathfrak{S}_n^3 \xrightarrow{q} \mathfrak{S}_n^2 \\ \downarrow r & & \downarrow r \quad \downarrow r \\ (\mathfrak{S}_n/\mathfrak{S}_\lambda \times \mathfrak{S}_n/\mathfrak{S}_\mu) \times (\mathfrak{S}_n/\mathfrak{S}_\mu \times \mathfrak{S}_n/\mathfrak{S}_\nu) & \xleftarrow{p} & \mathfrak{S}_n/\mathfrak{S}_\lambda \times \mathfrak{S}_n/\mathfrak{S}_\mu \times \mathfrak{S}_n/\mathfrak{S}_\nu \xrightarrow{q} \mathfrak{S}_n/\mathfrak{S}_\lambda \times \mathfrak{S}_n/\mathfrak{S}_\nu \end{array}$$

where q is the projection along the second factor, and p is the diagonal embedding of the second factor. We have $p^*r^* = r^*p^*$, and $q_*r^* = |\mathfrak{S}_\mu|r^*q_*$. Therefore, up to the factor $|\mathfrak{S}_\mu|$, pullbacks along $r_{\lambda\mu}$ fit in the following commutative square, where horizontal maps are given by multiplication in the corresponding algebra:

$$\begin{array}{ccc} \mathfrak{S}_{\lambda,\mu}^{\text{loc}} \otimes \mathfrak{S}_{\mu,\nu}^{\text{loc}} & \longrightarrow & \mathfrak{S}_{\lambda,\nu}^{\text{loc}} \\ \downarrow r_{\lambda\mu} \otimes r_{\mu\nu} & & \downarrow r_{\lambda\nu} \\ \mathcal{A}_{(Y_\mu^{-1})^\circ}^{\mathfrak{S}_n} \otimes \mathcal{A}_{(Y_\mu^{-1})^\circ}^{\mathfrak{S}_n} & \longrightarrow & \mathcal{A}_{(Y_\mu^{-1})^\circ}^{\mathfrak{S}_n} \end{array}$$

In particular, using (5) we see that

$$(15) \quad \begin{aligned} |\Gamma_g^{\lambda\mu}| |\Gamma_h^{\mu\nu}| \zeta_{(g,x)}^{\lambda\mu} * \zeta_{(h,y)}^{\mu\nu} &= \frac{1}{|\mathfrak{S}_\mu|} \left(\sum_{(a_1, a_2) \in \mathfrak{S}_\lambda \times \mathfrak{S}_\mu} \zeta_{(a_1 g a_2, x^{a_1})} \right) * \left(\sum_{(b_1, b_2) \in \mathfrak{S}_\mu \times \mathfrak{S}_\nu} \zeta_{(b_1 h b_2, y^{b_1})} \right) \\ &= \sum_{(a,b,c) \in \mathfrak{S}_\lambda \times \mathfrak{S}_\mu \times \mathfrak{S}_\nu} \zeta_{(agbhc, x^a (y_{Y_\mu^{-1}})^{agb})} = \sum_{b \in \mathfrak{S}_\mu} |\Gamma_{gbh}^{\lambda\nu}| \zeta_{(gbh, x (y^b_{Y_\mu^{-1}})^g)}. \end{aligned}$$

3.3. Generators. Let us introduce some elements in \mathfrak{S}_n , and compute their images under localization.

Polynomials. Let $\lambda \in \text{Comp}(n)$. Example 1.9 provides us with a homomorphism of algebras $\delta_\lambda : H_{G_n}^*(Y_\lambda) \rightarrow \mathfrak{S}_{\lambda,\lambda} \subset \mathfrak{S}_n$. For any $P \in \mathbf{P}_n^{\mathfrak{S}_\lambda} \simeq H_{G_n}^*(Y_\lambda)$, we will identify P with its image under δ_λ by abuse of notation.

Lemma 3.3. *For any $P \in \mathbf{P}_n^{\mathfrak{S}_\lambda}$, we have $\Xi_n(P) = \xi_{(1, Y_\lambda P)}^{\lambda\lambda}$.*

Proof. We have inclusions of fixed point sets:

$$\begin{array}{ccc} \mathfrak{S}_n/\mathfrak{S}_\lambda \times C^n & \xleftarrow{\Delta} & (\mathfrak{S}_n/\mathfrak{S}_\lambda)^2 \times C^n \\ \downarrow i_{Y_\lambda} & & \downarrow i_{Z_{\lambda,\lambda}} \\ Y_\lambda & \xleftarrow{\quad} & Z_{\lambda,\lambda} \end{array}$$

where the upper horizontal arrow is given by the diagonal embedding $\mathfrak{S}_n/\mathfrak{S}_\lambda \rightarrow (\mathfrak{S}_n/\mathfrak{S}_\lambda)^2$. Let $p_1, p_2 : (\mathfrak{S}_n/\mathfrak{S}_\lambda)^2 \times C^n \rightarrow \mathfrak{S}_n/\mathfrak{S}_\lambda \times C^n$ be the two natural projections. Applying Lemma 1.6, we get:

$$\Xi_n(P) = (p_1^* a_\lambda^*(Y_\lambda) \cdot p_2^* a_\lambda^*(Y_\lambda)) \cdot \Delta_* (a_\lambda^*(Y_\lambda)^{-1} \cdot i_{Y_\lambda}^*(P)) = \Delta_* (a_\lambda^*(Y_\lambda) \cdot a_\lambda^*(P)) = \xi_{(1, Y_\lambda P)}^{\lambda\lambda},$$

where we have used Corollary 2.6 to replace $i_{Y_\lambda}^*$ by a_λ^* . \square

Splits and merges. For $\lambda, \lambda' \in \text{Comp}(n)$, we say that λ' *subdivides* λ if $\mathfrak{S}_{\lambda'} \subset \mathfrak{S}_\lambda$, and write $\lambda' \subset \lambda$. In other words, λ' is obtained from λ by replacing each λ_i with $\lambda_i^{(1)}, \dots, \lambda_i^{(k_i)}$, which sum to λ_i . For such a pair of compositions, the closed embedding $\tilde{Q}_{\lambda'} \subset \tilde{Q}_\lambda$ induces a proper map $Y_{\lambda'} \rightarrow Y_\lambda$. We therefore have closed embeddings

$$\varepsilon_{\lambda',\lambda} : Y_{\lambda'} = Y_{\lambda'} \times_{Y_\lambda} Y_\lambda \hookrightarrow Y_{\lambda'} \times_{Q_n} Y_\lambda = Z_{\lambda',\lambda}, \quad \varepsilon_{\lambda,\lambda'} : Y_{\lambda'} = Y_\lambda \times_{Y_\lambda} Y_{\lambda'} \hookrightarrow Y_\lambda \times_{Q_n} Y_{\lambda'} = Z_{\lambda,\lambda'}.$$

In particular, let us define $S_{\lambda'}^\lambda = (\varepsilon_{\lambda',\lambda})_* [Y_{\lambda'}] \in \mathfrak{S}_{\lambda',\lambda}$, $M_{\lambda'}^\lambda = (\varepsilon_{\lambda,\lambda'})_* [Y_{\lambda'}] \in \mathfrak{S}_{\lambda,\lambda'}$.

Definition 3.4. We call $S_{\lambda'}^\lambda$ a *split*, and $M_{\lambda'}^\lambda$ a *merge*.

Lemma 3.5. *The images of splits and merges under localization are given by*

$$\Xi_n(S_{\lambda'}^\lambda) = \xi_{(1, Y_\lambda)}^{\lambda'\lambda}, \quad \Xi_n(M_{\lambda'}^\lambda) = \xi_{(1, Y_\lambda)}^{\lambda\lambda'}.$$

Proof. Consider the inclusions of fixed points sets:

$$\begin{array}{ccc} \mathfrak{S}_n/\mathfrak{S}_{\lambda'} \times C^n & \xleftarrow{\Delta} & \mathfrak{S}_n/\mathfrak{S}_{\lambda'} \times \mathfrak{S}_n/\mathfrak{S}_{\lambda} \times C^n \\ \downarrow i_{Y_{\lambda'}} & & \downarrow i_{Z_{\lambda',\lambda}} \\ Y_{\lambda'} & \xrightarrow{\varepsilon_{\lambda',\lambda}} & Z_{\lambda',\lambda} \end{array}$$

where the upper horizontal arrow sends $(g\mathfrak{S}_{\lambda'}, x)$ to $(g\mathfrak{S}_{\lambda'}, g\mathfrak{S}_{\lambda}, x)$. Let $p_{\natural} : \mathfrak{S}_n/\mathfrak{S}_{\lambda'} \times \mathfrak{S}_n/\mathfrak{S}_{\lambda} \times C^n \rightarrow \mathfrak{S}_n/\mathfrak{S}_{\natural} \times C^n$, $\natural \in \{\lambda, \lambda'\}$ be the two natural projections. Applying Lemma 1.6, we get:

$$\Xi_n(S_{\lambda}^{\lambda'}) = (p_{\lambda'}^* a_{\lambda'}^*(Y_{\lambda'}) \cdot p_{\lambda}^* a_{\lambda}^*(Y_{\lambda})) \cdot \Delta_* \left(a_{\lambda'}^*(Y_{\lambda'})^{-1} \cdot i_{Y_{\lambda'}}^*[Y_{\lambda'}] \right) = \Delta_* \left(a_{\lambda'}^*(Y_{\lambda'}) \cdot a_{\lambda'}^*[Y_{\lambda'}] \right) = \xi_{(1, Y_{\lambda})}^{\lambda' \lambda},$$

where we have used Corollary 2.6 to replace $i_{Y_{\lambda'}}^*$ by $a_{\lambda'}^*$. The expression for $\Xi_n(M_{\lambda'}^{\lambda})$ is obtained in an analogous fashion. \square

Lemma 3.6. *Let $\lambda, \lambda', \lambda'' \in \text{Comp}(n)$ such that $\lambda'' \subset \lambda' \subset \lambda$. Then $S_{\lambda'}^{\lambda''} S_{\lambda}^{\lambda'} = S_{\lambda}^{\lambda''}$, $M_{\lambda'}^{\lambda} M_{\lambda''}^{\lambda'} = M_{\lambda''}^{\lambda}$.*

Proof. We will only prove the first equality, the second being completely analogous. Consider the following commutative diagram:

$$\begin{array}{ccccc} Y_{\lambda''} \times Y_{\lambda'} & \xleftarrow{\Delta} & Y_{\lambda''} & \xlongequal{\quad} & Y_{\lambda''} \\ \downarrow \varepsilon \times \varepsilon & & \downarrow \varepsilon & & \downarrow \varepsilon \\ (Y_{\lambda''} \times_{Q_n} Y_{\lambda'}) \times (Y_{\lambda'} \times_{Q_n} Y_{\lambda}) & \xleftarrow{p'} & Y_{\lambda''} \times_{Q_n} Y_{\lambda'} \times_{Q_n} Y_{\lambda} & \xrightarrow{q} & Y_{\lambda''} \times_{Q_n} Y_{\lambda} \\ \downarrow & & \downarrow & & \downarrow \\ Y_{\lambda''} \times Y_{\lambda'} \times Y_{\lambda'} \times Y_{\lambda} & \xleftarrow{p} & Y_{\lambda''} \times Y_{\lambda'} \times Y_{\lambda} & & \end{array}$$

Here, q is the projection along the second factor, p and p' are the diagonal embeddings of the second factor, and the vertical maps ε are as in the definition of split and merge. We have $\Delta^* = \Delta_p^!$ by Proposition 1.2.(b), and $\varepsilon_* \Delta_p^! = (p')_p^! (\varepsilon \times \varepsilon)_*$ by Proposition 1.2.(c). As a consequence,

$$S_{\lambda'}^{\lambda''} S_{\lambda}^{\lambda'} = q_* (p')_p^! (\varepsilon \times \varepsilon)_* ([Y_{\lambda''}] \boxtimes [Y_{\lambda'}]) = \varepsilon_* \Delta^* ([Y_{\lambda''}] \boxtimes [Y_{\lambda'}]) = \varepsilon_* [Y_{\lambda''}] = S_{\lambda}^{\lambda''},$$

and we may conclude. \square

3.4. Diagrammatic presentation of \mathcal{S}_n . Let us identify compositions of the operators defined above with certain cord diagrams. Our strands are allowed to have multiplicities (i.e. non-negative integer labels), and we always read diagrams from bottom to top.

Polynomials. We depict the polynomial operators as boxes on strands. Namely, let $P = P_{(1)} \otimes \dots \otimes P_{(r)}$ be an element of $\mathbf{P}_n^{\mathfrak{S}_{\lambda}} = \bigotimes_i \mathbf{P}_{\lambda_i}^{\mathfrak{S}_{\lambda_i}}$. Then we draw P in one of the two following ways:

$$P = \begin{array}{c} \lambda_1 \\ | \\ \boxed{P_{(1)}} \\ | \\ \lambda_1 \end{array} \quad \dots \quad \begin{array}{c} \lambda_r \\ | \\ \boxed{P_{(r)}} \\ | \\ \lambda_r \end{array} = \begin{array}{c} \lambda_1 \quad \dots \quad \lambda_r \\ | \quad \dots \quad | \\ \boxed{P} \\ | \quad \dots \quad | \\ \lambda_1 \quad \dots \quad \lambda_r \end{array}.$$

When P is not a pure tensor, we have a similar equality between two box notations, but the left hand side becomes a sum over monomials in P .

Splits and merges. Take $\lambda = (\lambda_1, \dots, \lambda_r) \in \text{Comp}(n)$, and let $\lambda' = (\lambda_1, \dots, \lambda_{k-1}, \lambda_k^{(1)}, \lambda_k^{(2)}, \lambda_{k+1}, \dots, \lambda_r)$ for some $1 \leq k \leq r$, where $\lambda_k^{(1)} + \lambda_k^{(2)} = \lambda_k$. For such pair of compositions, we draw the corresponding split and merge as follows:

$$(16) \quad S_{\lambda}^{\lambda'} = \begin{array}{c} \lambda_1 \\ | \\ \dots \\ \lambda_1 \end{array} \quad \dots \quad \begin{array}{c} \lambda_k^{(1)} \quad \lambda_k^{(2)} \\ \diagdown \quad \diagup \\ \lambda_k \end{array} \quad \dots \quad \begin{array}{c} \lambda_r \\ | \\ \lambda_r \end{array}, \quad M_{\lambda'}^{\lambda} = \begin{array}{c} \lambda_1 \\ | \\ \dots \\ \lambda_1 \end{array} \quad \dots \quad \begin{array}{c} \lambda_k \\ \diagup \quad \diagdown \\ \lambda_k^{(1)} \quad \lambda_k^{(2)} \end{array} \quad \dots \quad \begin{array}{c} \lambda_r \\ | \\ \lambda_r \end{array}.$$

We call such splits and merges *elementary*. Lemma 3.6 tells us that splits and merges are associative:

Moreover, for any $\mu \subset \lambda$ the corresponding split S_μ^λ and merge M_μ^λ can be written as a product of elementary ones.

Crossings. Let λ, λ' be as above, and let $\lambda'' = (\lambda_1, \dots, \lambda_{k-1}, \lambda_k^{(2)}, \lambda_k^{(1)}, \lambda_{k+1}, \dots, \lambda_r)$ be obtained from λ' by permuting $\lambda_k^{(1)}$ with $\lambda_k^{(2)}$. Consider the element $R_{\lambda'}^{\lambda''} := S_{\lambda'}^{\lambda''} \cdot M_{\lambda'}^\lambda \in \mathfrak{S}_{\lambda', \lambda''}$, which we will call an *elementary permutation*. Diagrammatically, we will depict it as a crossing:

More generally, let $\lambda, \mu \in \text{Comp}(n)$, and assume that μ can be obtained from λ by a permutation of components. Let us pick such an element $w \in \mathfrak{S}_r$, where r is the number of components in λ ; note that it is not necessarily unique. Fix a presentation $w = s_{i_1} \dots s_{i_l}$, where $s_i \in \mathfrak{S}_r$ are transpositions, and l is the length of w . We then define $R_\lambda^\mu(w)$ as the corresponding product of elementary permutations.

Remark 3.7. Note that braid relations do not hold for elementary permutations $R_{\lambda'}^{\lambda''}$. In particular, the general definition of $R_\lambda^\mu(w)$ heavily depends on the choice of presentation of w . One could define these elements in a more canonical way using twisted bialgebra relations, but we do not need this for our purposes. However, this can be easily done for strands of multiplicity 1, see Theorem 4.15. There, the elements τ_r of $\mathfrak{W}_n(H^*(C))$ are the ‘‘canonical crossings’’, which differ from the naive split-merge crossings above by a constant.

3.5. Basis of \mathfrak{S}_n . Let $\lambda, \mu \in \text{Comp}(n)$, and consider $\mathfrak{S}_{\mu, \lambda} = H_*^{G_n}(Z_{\mu, \lambda})$. Recall from the proof of Lemma 2.9 that we have a stratification $Z_{\mu, \lambda} = \bigsqcup_{w \in \mu \mathfrak{S}_\lambda} Z_{\mu, \lambda}^w$, which induces a filtration $\{S_{\mu, \lambda}^w\}$ on $\mathfrak{S}_{\mu, \lambda}$ with associated graded $\bigoplus_w H_*^{G_n}(Z_{\mu, \lambda}^w)$. We have $H_*^{G_n}(Z_{\mu, \lambda}^w) = \mathbf{P}_n^{\mathfrak{S}_{\lambda'}}$, where $\lambda' \in \text{Comp}(n)$ is such that $w \mathfrak{S}_{\lambda'} w^{-1} = \Gamma_w^{\mu, \lambda}$. Since $Z_{\mu, \lambda}^w \cong G_n \times_{P_{\mu, \lambda}^w} (\tilde{Q}_\mu \cap w \tilde{Q}_\lambda)$, the T_n -fixed points $(Z_{\mu, \lambda}^w)^{T_n}$ are given by $\mathfrak{S}_n / \mathfrak{S}_{\mu'} \times C^n$. Note that

$$e(N_{\{1\} \times C^n} Z_{\mu, \lambda}^w) = e(T_{(F_e, F_w)} \Omega_w) e(N_{C^n}(\tilde{Q}_\mu \cap w \tilde{Q}_\lambda)) = \prod_{(i, j) \in N_\mu \cup g N_\lambda} (x_j - x_i) \prod_{(i, j) \in I_\mu \cap g I_\lambda} (x_i - x_j + \Delta_{ij}).$$

Let us denote $\beta_w = e(N_{\{1\} \times C^n} Z_{\mu, \lambda}^w)^{-1} \gamma_\lambda^w \gamma_\mu$. Furthermore, for each $\lambda \in \text{Comp}(n)$ pick a basis B_λ of $\mathbf{P}_n^{\mathfrak{S}_\lambda}$.

Lemma 3.8. *Let $\{b_{w, P} : w \in \mu \mathfrak{S}_\lambda, P \in B_{\lambda'}\}$ be a collection of elements in $\mathfrak{S}_{\mu, \lambda}$. Assume that*

$$\Xi_n(b_{w, P}) = \xi_{(w, \beta_w P)}^{\mu, \lambda} + \sum_{w' < w} \xi_{(w', a_{w'})}$$

for all w, P . Then $\{b_{w, P}\}$ is a \mathbb{k} -basis of $\mathfrak{S}_{\mu, \lambda}$.

Proof. It is enough to show that these elements form a basis after passing to the associated graded $\bigoplus_w H_*^{G_n}(Z_{\mu, \lambda}^w)$. An argument analogous to Lemma 2.5 shows that the composition $H_*^{G_n}(Z_{\mu, \lambda}^w) \rightarrow H_*^{T_n}((Z_{\mu, \lambda}^w)^{T_n}) \subset \mathfrak{S}_{\mu, \lambda}^{\text{loc}}$ is given by $P \mapsto \xi_{(w, P)}^{\mu, \lambda}$. The assumption on $b_{w, P}$ then implies that it is contained in $H_*^{G_n}(\overline{Z_{\mu, \lambda}^w})$. Consider the following diagram:

$$\begin{array}{ccccc} H_*^{G_n}(Z_{\mu, \lambda}^w) & \xleftarrow{j^*} & H_*^{G_n}(\overline{Z_{\mu, \lambda}^w}) & \xrightarrow{i_*} & H_*^{G_n}(Z_{\mu, \lambda}) \\ \downarrow \Xi_n^w & & \downarrow \Xi_n^w & & \downarrow \Xi_n \\ H_*^{T_n}((Z_{\mu, \lambda}^w)^{T_n})_{\text{loc}} & \xleftarrow{h} & H_*^{T_n}((\overline{Z_{\mu, \lambda}^w})^{T_n})_{\text{loc}} & \xrightarrow{\quad} & \mathfrak{S}_{\mu, \lambda}^{\text{loc}} \end{array}$$

We have $b_{w,P} = i_* b'$ for some $b' \in H_*^{G_n}(\overline{Z_{\mu,\lambda}^w})$, and the image of $b_{w,P}$ in the associated graded is given by $j^*(b')$. On the other hand, the left square in the diagram above commutes, and by Lemma 1.6 the right square commutes up to an Euler class, which equals precisely to $\xi_{1,\beta_w^{-1}}^{\mu\lambda}$. In fact, the closed embedding Ξ_n^w contributes $e(N_{\{1\} \times C^n} Z_{\mu,\lambda}^w)$, while Ξ_n contributes $e(N_{\{1\} \times C^n} Y_\mu)^{-1} e(N_{\{w\} \times C^n} Y_\lambda)^{-1} = (\gamma_\mu \gamma_\lambda^w)^{-1}$. Thus

$$\Xi_n^w \circ j^*(b') = h \circ \Xi_n^{\prec w}(b') = \xi_{1,\beta_w^{-1}}^{\mu\lambda} h \circ \Xi_n \circ i_*(b') = \xi_{(w,\beta_w^{-1}\beta_w P)}^{\mu\lambda} = \xi_{(w,P)}^{\mu\lambda}.$$

Since the localization map Ξ_n is injective, we conclude that the image of $b_{w,P}$ in the associated graded is P . Running over all $w \in {}^\mu\mathfrak{S}^\lambda$, $P \in B_{\lambda'}$ we obtain a basis of $\mathcal{S}_{\mu,\lambda}$. \square

Let $g \in {}^\mu\mathfrak{S}^\lambda$. As before, let $\mu' \in \text{Comp}(n)$ be such that $\Gamma_g^{\mu\lambda} \simeq \mathfrak{S}_{\mu'}$, and let λ' be such that $\mathfrak{S}_{\lambda'} = g^{-1}\mathfrak{S}_{\mu'}g = \mathfrak{S}_\lambda \cap g\mathfrak{S}_\mu g^{-1}$. Note that g induces a permutation w on the set of components of λ' , which transforms λ' into μ' . Pick $P \in \mathbf{P}_n^{\mathfrak{S}_{\lambda'}}$. For each such pair (g, P) , we construct the following elements of $\mathcal{S}_{\mu,\lambda}$:

$$(17) \quad \Psi_g^P = M_{\mu'}^\mu R_{\lambda'}^{\mu'}(w) P S_\lambda^{\lambda'}, \quad \Psi_g = \Psi_g^1 = M_{\mu'}^\mu R_{\lambda'}^{\mu'}(w) S_\lambda^{\lambda'}.$$

Example 3.9. Let $\lambda = (3, 1)$, $\mu = (2, 2)$, $g = (1, 3, 4, 2)$, and $P = x_1^2 x_2 x_3$. Then $\lambda' = (1, 2, 1)$, $\mu' = (1, 1, 2)$, $w = (1, 3, 2)$, and we have

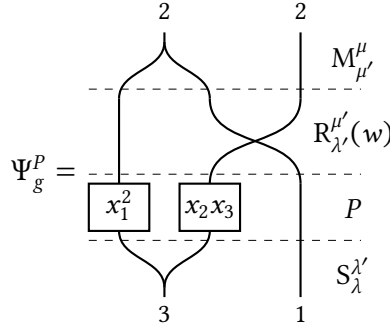

Theorem 3.10. *The following set is a basis for $\mathcal{S}_{\mu,\lambda}$:*

$$\{ \Psi_g^P : g \in {}^\mu\mathfrak{S}^\lambda, P \in B_{\lambda'} \}.$$

Remark 3.11. Note that when $\mu = (n)$ is the trivial composition, we have $Z = Y_\lambda$, and this statement follows from the isomorphism (11).

Proof. In order to simplify the notation, we will write $Z = Z_{\mu,\lambda}$ throughout the proof. In light of Lemma 3.8, we need to compute highest terms of $\Xi_n(\Psi_g^P)$. From now on, we will denote the presence of lower terms by ellipsis.

We begin by computing elementary permutations. Let ν, λ', λ'' be as in the definition of $R_{\lambda'}^{\lambda''}$; we write ν instead of λ to avoid conflict of notation. Note that the longest element in $\mathfrak{S}_{\lambda''} \setminus \mathfrak{S}_\nu / \mathfrak{S}_{\lambda'} \subset \lambda'' \mathfrak{S}^{\lambda'}$ is the permutation that exchanges the components $\nu_k^{(1)}$ and $\nu_k^{(2)}$; denote it by s . Using formula (15) and Lemma 3.5, we obtain:

$$\begin{aligned} R_{\lambda'}^{\lambda''} &= S_\nu^{\lambda''} \cdot M_{\lambda'}^\nu = \xi_{(1,\gamma_\nu)}^{\lambda''\nu} * \xi_{(1,\gamma_\nu)}^{\nu\lambda'} = \frac{1}{|\mathfrak{S}_{\lambda''}||\mathfrak{S}_{\lambda'}|} \sum_{b \in \mathfrak{S}_\nu} |\Gamma_b^{\lambda''\lambda'}| \xi_{(b,\gamma_\nu)}^{\lambda''\lambda'} = \frac{|\Gamma_s^{\lambda''\lambda'}|}{|\mathfrak{S}_{\lambda''}||\mathfrak{S}_{\lambda'}|} \left(\sum_{b \in \mathfrak{S}_{\lambda'}} \xi_{(sb,\gamma_\nu)}^{\lambda''\lambda'} \right) + \dots \\ &= \xi_{(s,\gamma_\nu)}^{\lambda''\lambda'} + \dots \end{aligned}$$

Next, consider general permutations. Let $w \in \mathfrak{S}_r$ be the permutation of components of λ' defined by g , and fix a reduced presentation $w = s_l \dots s_1$ ³. We write $w_i := s_i \dots s_1 \in \mathfrak{S}_r$. Let $\lambda^i = w_i(\lambda')$, and ν^i the intermediate composition between λ^{i-1} and λ^i , i.e. ν^i is such that we have $R_{\lambda^{i-1}}^{\lambda^i} = S_{\nu^i}^{\lambda^i} \cdot M_{\lambda^{i-1}}^{\nu^i}$. Note that $\lambda^l = \mu'$. Let us write $M_j^i = [\tilde{\lambda}_{j-1}^i + 1, \tilde{\lambda}_j^i]$, and $M_{jk}^i = M_j^i \times M_k^i$. We also denote by s_i the corresponding longest element in $\mathfrak{S}_{\lambda^i} \setminus \mathfrak{S}_{\nu^i} / \mathfrak{S}_{\lambda^{i-1}}$ as before.

³here, s_i does not stand for the transposition $(i, i+1)$, but rather for some simple transposition $(j, j+1)$, $1 \leq j \leq r-1$

Lemma 3.12. *Assume $s'_l b_{l-1} s'_{l-1} \dots b_1 s'_1 \in \mathfrak{S}_{\mu'} g \mathfrak{S}_{\lambda'}$, where $s'_i \in \mathfrak{S}_{\lambda^i} \setminus \mathfrak{S}_{\nu^i} / \mathfrak{S}_{\lambda^{i-1}}$, and $b_i \in \mathfrak{S}_{\lambda^i}$. Then $s'_i = s_i$ for all i .*

In particular, the highest term of $R_{\lambda'}^{\mu'}(w)$ must be contained in the product of highest terms of elementary permutations. By definition, conjugation by s_i sends $\mathfrak{S}_{\lambda^{i-1}}$ to \mathfrak{S}_{λ^i} . As a consequence $s_{i+1} b s_i$ defines the same class in $\mathfrak{S}_{\lambda^{i+1}} \setminus \mathfrak{S}_n / \mathfrak{S}_{\lambda^{i-1}}$ for any $b \in \mathfrak{S}_{\lambda^i}$. Moreover, we have $|\Gamma_{s_{i+1}}^{\lambda^{i+1} \lambda^i}| = |\Gamma_{s_{i+1} b s_i}^{\lambda^{i+1} \lambda^{i-1}}| = |\mathfrak{S}_{\lambda^{i+1}}|$, so that all coefficients in (15) cancel out. We get

$$R_{\lambda'}^{\mu'}(w) = R_{\lambda^{l-1}}^{\mu'} \dots R_{\lambda^1}^{\mu'} = \xi_{(s_l, \gamma_{\nu^l})}^{\mu' \lambda^{l-1}} * \dots * \xi_{(s_1, \gamma_{\nu^1})}^{\lambda^1 \lambda'} + \dots = \xi_{(g, E)}^{\mu' \lambda'} + \dots;$$

$$E = \gamma_{\nu^l} (\gamma_{\nu^{l-1}} \gamma_{\lambda^{l-1}}^{-1})^{s_l} \dots (\gamma_{\nu^1} \gamma_{\lambda^1}^{-1})^{s_1 \dots s_2}.$$

Denote $\zeta_0 = \gamma_{\lambda'}$, and $\zeta_i = (\gamma_{\nu^i}^{-1} \gamma_{\lambda^i}) \zeta_{i-1}^{s_i}$ for $i > 0$. Recall that r is the number of components in μ' and let A_μ be the subset of $[1, r]^2$ such that we have $N_\mu = \bigsqcup_{(j,k) \in A_\mu} M_{jk}^l$. By analogy, we define $N_{\mu,i} = \bigsqcup_{(j,k) \in A_\mu} M_{jk}^i$, and $I_{\mu,i} = N_{\mu,i} \cup (\bigsqcup_j M_{jj}^i \setminus \{(j, j) : 1 \leq j \leq n\})$.

Lemma 3.13. *Let $g_i = s_i \dots s_1 \in \mathfrak{S}_n$. We have*

$$\zeta_i = \prod_{(p,q) \in g_i N_\lambda \cup N_{\mu,i}} (x_q - x_p) \prod_{(p,q) \in g_i I_\lambda \cap I_{\mu,i}} (x_p - x_q + \Delta_{pq}).$$

An immediate consequence of the lemma above is that $\gamma_{\mu'}^{-1} E (\gamma_{\lambda'}^{-1})^g = \zeta_l^{-1} = \beta_g (\gamma_\lambda \gamma_\mu)^{-1}$. This formula allows us to compute the highest term of Ψ_g^P :

$$\begin{aligned} \Xi_n(\Psi_g^P) &= \Xi_n(M_{\mu'}^\mu R_{\lambda'}^{\mu'}(w) P S_\lambda^{\lambda'}) = \xi_{(1, \gamma_\mu)}^{\mu \mu'} * (\xi_{(g, E)}^{\mu' \lambda'} + \dots) * \xi_{(1, P \gamma_\lambda)}^{\lambda' \lambda} \\ &= \xi_{(1, \gamma_\mu)}^{\mu \mu'} * \left(\frac{|\Gamma_g^{\mu' \lambda}| |\mathfrak{S}_{\lambda'}|}{|\Gamma_1^{\lambda' \lambda}| |\Gamma_g^{\mu' \lambda'}|} \xi_{(g, E(P \gamma_\lambda \gamma_{\lambda'}^{-1})^g)}^{\mu' \lambda} + \dots \right) = \frac{|\Gamma_g^{\mu \lambda}| |\mathfrak{S}_{\mu'}|}{|\Gamma_1^{\mu \mu'}| |\Gamma_g^{\mu' \lambda}|} \xi_{(g, P^g \gamma_\mu \gamma_{\mu'}^{-1} E (\gamma_\lambda \gamma_{\lambda'}^{-1})^g)}^{\mu \lambda} + \dots \\ &= \xi_{(g, P^g \beta_g)}^{\mu \lambda} + \dots \end{aligned}$$

Substituting $P \rightsquigarrow P^g$, we may conclude by Lemma 3.8. \square

Corollary 3.14. *The Schur algebra \mathcal{S}_n is generated by polynomials and elementary splits and merges.*

Proof of Lemma 3.12. The condition on s'_i 's can be rewritten as $g = b_l s'_l \dots b_1 s'_1$. Suppose the equality $s'_i = s_i$ does not always hold. Let $i \in [1, r]$ be the minimal index such that for some k we have $w_k(i) \neq w_{k-1}(i)$ and $s_k \neq s'_k$. Consider the smallest such k for this i . Pick $p_0 \in M_i^0 = [\tilde{\lambda}_{i-1} + 1, \tilde{\lambda}'_i]$ such that $s'_k b_{k-1} s'_{k-1} \dots b_1 s'_1(p_0)$ lies in $M_{w_{k-1}(i)}^k$, and consider the sequence $p_j = b_j s'_j(p_{j-1})$. Let a_j be such that $p_j \in M_{w_j(a_j)}^j$; note that $a_0 = i$.

Pictorially, we draw the presentation $w = s_l \dots s_1$ as a diagram on r strands, going from bottom to top and numbered 1 to r :

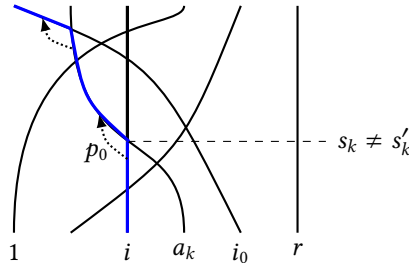

Since this presentation is reduced, each pair of strands intersects at most once. Then a_j is the number of strand, on which the image of p_0 is located after applying the j -th crossing. Depending on s'_j , at each crossing we either swap the strand or not. The condition $g = b_l s'_l \dots b_1 s'_1$ tells us that as p_0 traverses the diagram from bottom to top, it comes back to the i -th strand. The minimality of i implies that we can only swap the strand on intersections with strands number i, \dots, r . However, for $i_0 > i$ the i_0 -th strand has to intersect the i -th strand first before intersecting the a_k -th strand. Therefore even if we swap strands, the new strand cannot intersect the i -th strand again, so that $g(p_0) = p_l \notin g(M_i^0)$. We have arrived at a contradiction. \square

Proof of Lemma 3.13. For $i = 0$, the claim follows from the definition of $\gamma_{\lambda'}$. Let $i > 0$ and proceed by induction. Suppose $s_i = (t, t + 1)$; then we have $I_{\nu^i} = I_{\lambda^i} \sqcup M_{t+1,t}^i$, $N_{\lambda^i} = N_{\nu^i} \sqcup M_{t,t+1}^i$. Looking at the formula for ζ_i , we thus need to prove the following equalities between subsets in $[1, n] \times [1, n]$:

$$\begin{aligned} g_i I_{\lambda} \cap s_i I_{\mu, i-1} &= (g_i I_{\lambda} \cap I_{\mu, i}) \sqcup M_{t+1,t}^i, \\ g_i N_{\lambda} \cup N_{\mu, i} &= (g_i N_{\lambda} \cup s_i N_{\mu, i-1}) \sqcup M_{t,t+1}^i. \end{aligned}$$

We will only prove the second identity; the first one can be obtained analogously by passing to complementary index sets and substituting $(i, j) \mapsto (j, i)$.

It is easy to check that $N_{\mu, i} \setminus s_i N_{\mu, i-1} = M_{t,t+1}^i$, and conversely $s_i N_{\mu, i-1} \setminus N_{\mu, i} = M_{t+1,t}^i$. Therefore

$$(18) \quad g_i N_{\lambda} \cup N_{\mu, i} = g_i N_{\lambda} \cup \left((s_i N_{\mu, i-1} \setminus M_{t+1,t}^i) \sqcup M_{t,t+1}^i \right).$$

Assume that $t = g_{i-1}(k_1)$, $t + 1 = g_{i-1}(k_2)$; note that we automatically have $k_1 < k_2$. We cannot have crossings between the strands which split off the same thick strand. Thus k_1 and k_2 lie in different components of λ , and $N_{\lambda} \supset M_{k_1, k_2}^0$, $N_{\lambda} \cap M_{k_2, k_1}^0 = \emptyset$ by definition of N_{λ} . Applying g_i , we get $M_{t+1,t}^i \subset g_i N_{\lambda}$ and $M_{t,t+1}^i \cap g_i N_{\lambda} = \emptyset$, which together with (18) implies the desired identity. \square

3.6. Polynomial representation. The localized Schur algebra $\mathcal{S}_n^{\text{loc}}$ admits an action on

$$P_n^{\text{loc}} := \bigoplus_{\lambda} \left(H^*(C)^{\otimes n}(x_1, \dots, x_n) \right)^{\mathfrak{S}_{\lambda}}$$

by Proposition 1.8. Similarly to (15), one shows that

$$(19) \quad \xi_{(g,x)}^{\mu\lambda} \cdot y = \frac{1}{|\Gamma_g^{\mu\lambda}|} \sum_{a \in \mathfrak{S}_{\mu}} \left(x(y\gamma_{\lambda}^{-1})^g \right)^a.$$

By Proposition 1.11, we have a commutative square

$$(20) \quad \begin{array}{ccc} \mathcal{S}_n & \longrightarrow & \text{End } P_n \\ \downarrow & & \downarrow \\ \mathcal{S}_n^{\text{loc}} & \longrightarrow & \text{End } P_n^{\text{loc}} \end{array}$$

Theorem 3.15. *Let λ, λ' be as in the definition of elementary splits and merges. The algebra \mathcal{S}_n has a faithful representation on P_n such that*

- polynomials $P \in \mathbf{P}_n^{\mathfrak{S}_{\lambda}}$ act by multiplication on $H_{G_n}^*(Y_{\lambda}) \simeq \mathbf{P}_n^{\mathfrak{S}_{\lambda}}$,
- the split \mathcal{S}_{λ}' acts by the natural inclusion of rings $\mathbf{P}_n^{\mathfrak{S}_{\lambda}} \rightarrow \mathbf{P}_n^{\mathfrak{S}_{\lambda}'}$,
- the merge \mathcal{M}_{λ}' acts by the following operator:

$$P \mapsto \sum_{a \in \mathfrak{S}_{\lambda}/\mathfrak{S}_{\lambda'}} \left(y \prod_{(i,j) \in N_{\lambda}^a} \left(1 + \frac{\Delta_{ij}}{x_j - x_i} \right) \right)^a, \quad N_{\lambda'}^{\lambda} = [\tilde{\lambda}_{k-1} + 1, \tilde{\lambda}_{k-1} + \lambda_k^{(1)}] \times [\tilde{\lambda}_{k-1} + \lambda_k^{(1)} + 1, \tilde{\lambda}_k].$$

Proof. The vertical maps in diagram (20) are injective by Lemma 2.9 and Thom isomorphism. Moreover, the restriction of $\mathcal{S}_n^{\text{loc}} \rightarrow \text{End } P_n^{\text{loc}}$ to $\mathcal{S}_{\lambda, \mu}^{\text{loc}}$ is nothing else than the pullback $r_{\lambda, \mu}^*$, and is therefore injective as well. The faithfulness of the polynomial representation $\mathcal{S}_n \rightarrow \text{End } P_n$ follows.

Let us compute the action of generators by applying Ξ_n , and using formula (19):

$$\begin{aligned} P \cdot y &= \xi_{(1, P\gamma_{\lambda})}^{\lambda\lambda} \cdot y = \frac{1}{|\mathfrak{S}_{\lambda}|} \sum_{a \in \mathfrak{S}_{\lambda}} (P\gamma_{\lambda} y \gamma_{\lambda}^{-1})^a = P y; \\ \mathcal{S}_{\lambda}' \cdot y &= \xi_{(1, \gamma_{\lambda})}^{\lambda'\lambda} \cdot y = \frac{1}{|\mathfrak{S}_{\lambda'}|} \sum_{a \in \mathfrak{S}_{\lambda'}} (\gamma_{\lambda} y \gamma_{\lambda}^{-1})^a = y; \\ \mathcal{M}_{\lambda'}^{\lambda} \cdot y &= \xi_{(1, \gamma_{\lambda})}^{\lambda\lambda'} \cdot y = \frac{1}{|\mathfrak{S}_{\lambda'}|} \sum_{a \in \mathfrak{S}_{\lambda}} (\gamma_{\lambda} y \gamma_{\lambda}^{-1})^a = \sum_{a \in \mathfrak{S}_{\lambda}/\mathfrak{S}_{\lambda'}} \left(\frac{\prod_{(i,j) \in I_{\lambda} \setminus I_{\lambda'}} (x_i - x_j + \Delta_{ij})}{\prod_{(i,j) \in N_{\lambda'} \setminus N_{\lambda}} (x_j - x_i)} \cdot y \right)^a. \end{aligned}$$

We conclude by observing that $N_{\lambda'} \setminus N_{\lambda} = N_{\lambda'}^{\lambda}$, and $(i, j) \in I_{\lambda} \setminus I_{\lambda'}$ if and only if $(j, i) \in N_{\lambda'}^{\lambda}$. \square

Remark 3.16. As in [Prz19], this polynomial representation can be realized inside a tensor power of cohomological Hall algebra of torsion sheaves on C . We do not pursue this point of view here.

Example 3.17. Consider the case $n = 2$. Denote the inclusion $\mathbf{P}_2^{\mathfrak{S}_2} \subset \mathbf{P}_2$ by f_2 . We have only one possible split and merge respectively; we write $S = S_2^{(1,1)}$, $M = M_{(1,1)}^2$, and omit labels on strands. Using Theorem 3.10, one can check that \mathcal{S}_2 is generated by S , M and the polynomial subalgebras $\mathbf{P}_2^{\mathfrak{S}_2}$, \mathbf{P}_2 , subject to the following relations:

$$\begin{array}{c} \text{Diagram: a box labeled } Q \text{ with a loop above and below} \end{array} = \begin{array}{c} \text{Diagram: a box labeled } Q + s_1(Q) - \frac{\Delta_{12}(Q - s_1(Q))}{x_1 - x_2} \end{array}, \quad \begin{array}{c} \text{Diagram: a split (Y-shape) with a box labeled } P \text{ below} \end{array} = \begin{array}{c} \text{Diagram: a merge (inverted Y-shape) with a box labeled } f_2(P) \text{ above} \end{array}, \quad \begin{array}{c} \text{Diagram: a box labeled } P \text{ with a split above} \end{array} = \begin{array}{c} \text{Diagram: a merge (inverted Y-shape) with a box labeled } f_2(P) \text{ below} \end{array}, \quad P \in \mathbf{P}_2^{\mathfrak{S}_2}, Q \in \mathbf{P}_2.$$

Remark 3.18. When $C = \mathbb{P}^1$, we have $\mathbf{P}_n = \mathbb{k}[x_1, \dots, x_n, c_1, \dots, c_n]/(c_1^2, \dots, c_n^2)$ and $\Delta_{ij} = c_i + c_j$. For instance, $M \in \mathcal{S}_2^{\mathbb{P}^1}$ acts on the polynomial representation by $(1 + s_1) - \frac{(c_1 + c_2)(1 - s_1)}{x_1 - x_2}$.

4. KLR ALGEBRA OF A SMOOTH CURVE

In this section we study a subalgebra of \mathcal{S}_n , which admits a simpler description.

4.1. Demazure operators. Let us recall the definition and basic properties of Demazure operators [Dem73].

Definition 4.1. For $r \in [1, n - 1]$, denote by ∂_r the *Demazure operator*

$$\partial_r : \mathbb{k}[x_1, \dots, x_n] \rightarrow \mathbb{k}[x_1, \dots, x_n], \quad P \mapsto (P - s_r(P))/(x_r - x_{r+1}).$$

Note that we have $\partial_r(P) = 0$ if and only if $s_r(P) = P$. In particular, a polynomial P is symmetric if and only if it is annihilated by all ∂_r for $r \in [1, n - 1]$.

The following relations are well-known.

Lemma 4.2. *We have*

$$\begin{aligned} \partial_r^2 &= 0 && \text{for } r \in [1, n - 1], \\ \partial_r \partial_t &= \partial_t \partial_r && \text{for } r, t \in [1, n - 1], |r - t| > 1, \\ \partial_r \partial_{r+1} \partial_r &= \partial_{r+1} \partial_r \partial_{r+1} && \text{for } r \in [1, n - 2]. \end{aligned}$$

For each $w \in \mathfrak{S}_n$, fix a reduced expression $w = s_{k_1} \dots s_{k_r}$ and define $\partial_w = \partial_{k_1} \dots \partial_{k_r}$. Since Demazure operators satisfy braid relations, this definition is independent of the choice of a reduced expression. Moreover, the square-zero relation implies that we have $\partial_{k_1} \dots \partial_{k_r} = 0$ if $s_{k_1} \dots s_{k_r}$ is not a reduced expression.

Let $w_{0,n}$ be the longest element in \mathfrak{S}_n .

Lemma 4.3. *For any $P \in \mathbb{k}[x_1, \dots, x_n]$, the polynomial $\partial_{w_{0,n}}(P)$ is symmetric.*

Proof. Since we have $\ell(s_r w_{0,n}) < \ell(w_{0,n})$ for each $r \in [1, n - 1]$, we get $\partial_r \partial_{w_{0,n}} = 0$. Then the polynomial $\partial_{w_{0,n}}(P)$ is symmetric because for each $r \in [1, n - 1]$ we have $\partial_r(\partial_{w_{0,n}}(P)) = 0$. \square

Definition 4.4. For positive integers a, b with $a + b = n$ consider the permutation $w_{0,a,b} \in \mathfrak{S}_n$ given by

$$w_{0,a,b}(i) = \begin{cases} i + b & \text{if } 1 \leq i \leq a, \\ i - a & \text{if } a < i \leq n. \end{cases}$$

Lemma 4.5. *For any $P \in \mathbb{k}[x_1, \dots, x_n]^{\mathfrak{S}_a \times \mathfrak{S}_b}$, we have*

$$\partial_{w_{0,a,b}}(P) = \sum_{w \in \mathfrak{S}_n / (\mathfrak{S}_a \times \mathfrak{S}_b)} w \left(\frac{P}{\prod_{1 \leq i \leq a} \prod_{a+1 \leq j \leq n} (x_i - x_j)} \right)$$

Proof. Analogous to [Ful97, Lemma 12]. \square

Corollary 4.6. *For any $P \in \mathbb{k}[x_1, \dots, x_n]^{\mathfrak{S}_a \times \mathfrak{S}_b}$, we have $\partial_{w_{0,a,b}}(P) \in \mathbb{k}[x_1, \dots, x_n]^{\mathfrak{S}_n}$.*

Remark 4.7. Applying Lemma 4.5, we can rewrite the action of merge operator $M_{\lambda'}^\lambda \in \mathfrak{S}_n$ on the polynomial representation (see Theorem 3.15) as follows:

$$P \mapsto \partial_{w_{0,a,b}} \left(P \prod_{(i,j) \in N_{\lambda'}^\lambda} (x_i - x_j - \Delta_{ij}) \right),$$

where $a = \lambda_k^{(1)}$, $b = \lambda_k^{(2)}$ and the Demazure operator $\partial_{w_{0,a,b}}$ is applied to the variables in positions $\lambda_{k-1} + 1, \lambda_{k-1} + 2, \dots, \lambda_k$.

4.2. Affinized symmetric algebras. Let $F = \bigoplus_i F_i$ be a $\mathbb{Z}_{\geq 0}$ -graded unital finite dimensional \mathbb{k} -algebra. Further, let $\sigma : F \otimes F \rightarrow \mathbb{k}$ be a non-degenerate graded pairing, such that $\sigma(fg, h) = \sigma(f, gh)$ and $\sigma(f, g) = \sigma(g, f)$ for any $f, g, h \in F$. This makes (F, σ) into a symmetric Frobenius algebra. An example of such algebra is given by the cohomology ring $H^*(X, \mathbb{k})$ of any smooth projective variety X .

Let $m : F \otimes F \rightarrow F$ be the product in F , and $\Delta : F \rightarrow F \otimes F$ be its dual with respect to σ . The tensor product $F^{\otimes n}$ has a natural \mathfrak{S}_n -action. For any $1 \leq i < j \leq n$, consider the \mathbb{k} -linear map

$$i_{i,j} : F^{\otimes 2} \rightarrow F^{\otimes n}, \quad f \otimes g \mapsto 1 \otimes \dots \otimes 1 \otimes f \otimes 1 \otimes \dots \otimes 1 \otimes g \otimes 1 \otimes \dots \otimes 1,$$

where f and g appear at the i -th and j -th position respectively. Set $\Delta_{i,j} := i_{i,j}(\Delta(1)) \in F^{\otimes n}$.

Let $s_i = (i, i+1)$, $1 \leq i < n$ be the elementary transpositions in \mathfrak{S}_n . We will denote the image of s_i in the group algebra $\mathbb{k}\mathfrak{S}_n$ by τ_i , and more generally for any $w \in \mathfrak{S}_n$ we denote its image by τ_w . The following algebra is defined in [KM19, Definition 3.2] (see also [Sav18, Definition 3.1] for a version with non-symmetric F).

Definition 4.8. The *affinized symmetric algebra* $\mathfrak{W}_n = \mathfrak{W}_n(F)$ of rank n is the quotient of the free product $\mathbb{k}[x_1, \dots, x_n] \star F^{\otimes n} \star \mathbb{k}\mathfrak{S}_n$ by the following relations:

$$\begin{aligned} x_i f &= f x_i, & \tau_i f &= s_i(f) \tau_i \quad \text{for all } f \in F^{\otimes n}, \\ \tau_i x_j &= x_{s_i(j)} \tau_i - (\delta_{i,j} - \delta_{i+1,j}) \Delta_{i,i+1}, \end{aligned}$$

where $\delta_{i,j}$ is the Kronecker symbol.

Remark 4.9. The algebra in the definition above differs from the algebra in [KM19, Definition 3.2] by the sign in the last relation. However, we could eliminate this difference if we replace x_i by $-x_i$.

For any $f \in F$ and $1 \leq r \leq n$, denote by f_r the image of $1^{\otimes r-1} \otimes f \otimes 1^{\otimes n-r} \in F^{\otimes n}$ in \mathfrak{W}_n . While it is not obvious that the natural map $F^{\otimes n} \rightarrow \mathfrak{W}_n$ is injective, this follows from the lemma below.

Lemma 4.10 ([KM19, Theorem 3.8]). *Let B_F be a basis of F . The affinized symmetric algebra \mathfrak{W}_n has the following basis:*

$$\left\{ \tau_w x_1^{a_1} x_2^{a_2} \dots x_n^{a_n} (f^{(1)})_1 (f^{(2)})_2 \dots (f^{(n)})_n : w \in \mathfrak{S}_n, a_r \in \mathbb{N}, f^{(i)} \in B_F \right\}.$$

Let us introduce a grading on \mathfrak{W}_n by setting $\deg \tau = 0$, $\deg x_i = 2$, $\deg f = \deg_F f$. This makes \mathfrak{W}_n into a graded algebra. We write $\mathfrak{W}_n = \bigoplus_i \mathfrak{W}_n[i]$, where $\mathfrak{W}_n[i]$ is the subspace of degree i .

Corollary 4.11. *We have the following formula for the graded dimension of \mathfrak{W}_n :*

$$\sum_i t^i \dim \mathfrak{W}_n[i] = n! \left(\frac{P_t(F)}{1-t^2} \right)^n,$$

where $P_t(F) = \sum_i t^i \dim F_i$ is the graded dimension of F .

Let us describe a faithful representation of \mathfrak{W}_n . The vector space $\mathbf{P}_n(F) := \mathbb{k}[x_1, \dots, x_n] \otimes F^{\otimes n}$ admits several natural \mathfrak{S}_n -actions. First, there is an action permuting x_i 's and leaving $F^{\otimes n}$ intact; denote the operators on $\mathbf{P}_n(F)$ induced by the elementary transpositions by s_1^X, \dots, s_{n-1}^X . Conversely, there is an action permuting components of $F^{\otimes n}$ without touching x 's; denote the operators on $\mathbf{P}_n(F)$ induced by the elementary transpositions by s_1^f, \dots, s_{n-1}^f . Set also $s_k = s_k^X s_k^f$, the operators s_1, \dots, s_{n-1} correspond to the diagonal \mathfrak{S}_n -action, exchanging simultaneously the x_i 's and the components of $F^{\otimes n}$.

Lemma 4.12. *The algebra \mathfrak{W}_n has a faithful representation in $\mathbf{P}_n(F)$ such that*

- x_i acts by multiplication by $x_i \in \mathbf{P}_n(F)$;

- $f \in F^{\otimes n}$ acts by multiplication by $f \in \mathbf{P}_n(F)$;
- τ_i acts by $s_i - \Delta_{i,i+1} \partial_i^X$, where $\partial_i^X := \frac{1-s_i^X}{x_i-x_{i+1}}$ is the Demazure operator on $\mathbb{k}[x_1, \dots, x_n]$.

Proof. The formulas above yield a representation of \mathfrak{W}_n by [KM19, Lemma 3.7]. The faithfulness follows from the proof of [KM19, Theorem 3.8]. Indeed, it is shown there that the basis elements of \mathfrak{W}_n in Lemma 4.10 act on $\mathbf{P}_n(F)$ by linearly independent operators. \square

4.3. KLR algebras of curves. Let $n \in \mathbb{N}_+$, and let 1^n be the partition of n into 1's. Then $\mathcal{S}_{1^n, 1^n} \subset \mathcal{S}_n$ is a subalgebra; we denote it by $\mathcal{R}_n = \mathcal{R}_n^C$ and refer to it as the (torsion) KLR algebra of C of degree n . More explicitly, \mathcal{R}_n is the convolution algebra $\mathcal{A}(\pi') = H_{G_n}^*(Z_n)$, where $\pi' : Y_{1^n} \rightarrow Q_n$ is the restriction of π (see Section 3) to Y_{1^n} .

Notation. In order to unclutter the notation, we will write Z_n instead of $Z_{1^n, 1^n}$ for the correspondence $Y_{1^n} \times_{Q_n} Y_{1^n}$ throughout this section.

For any $1 \leq i \leq n-1$, let us consider the ordered partition σ_i of n with i -th term equal to 2, and other terms equal to 1:

$$\sigma_i = (1, \dots, \underbrace{2}_{i\text{-th}}, \dots, 1).$$

We have a natural map $Y_{1^n} \rightarrow Y_{\sigma_i}$, induced by the B_n -equivariant embedding $\tilde{Q}_{1^n} \subset \tilde{Q}_{\sigma_i}$. Consider the following correspondences:

$$Z_n^i := Y_{1^n} \times_{Y_{\sigma_i}} Y_{1^n}, \quad Z_n^{\sigma_i} := \overline{Z_n^i \setminus Y_{1^n}} \subset Z_n.$$

Let us denote $\tau_i := [Z_n^{\sigma_i}] \in \mathcal{R}_n^C$. Unlike for the full Schur algebra, we can use the notations from Section 1.4 without any adjustments for \mathcal{R}_n . We set $X = C^n$, $\Gamma = \mathfrak{S}_n$, and $\gamma = \gamma_{1^n}$. Lemma 3.3 then implies that $\Xi_n(P) = \tilde{\xi}_{(1,P)}$ for any $P \in \mathbf{P}_n \simeq H_{G_n}^*(Y_{1^n})$.

Proposition 4.13. *We have $\Xi_n(\tau_i) = \tilde{\xi}_{1, \frac{\Delta_{i,i+1}}{x_{i+1}-x_i}} + \tilde{\xi}_{s_i, 1 + \frac{\Delta_{i,i+1}}{x_{i+1}-x_i}}$.*

Proof. By definition of $Z_n^{\sigma_i}$, we have $Z_n^i = Y_{1^n} \cup Z_n^{\sigma_i}$. Since $Z_n^i = Y_{1^n} \times_{Y_{\sigma_i}} Y_{1^n}$, we have $[Z_n^i] = S_{\sigma_i}^{1^n} M_{1^n}^{\sigma_i}$ inside \mathcal{S}_n . Using Lemma 3.5 and formula (15), we obtain

$$\begin{aligned} \Xi_n(\tau_i) &= \Xi_n([Z_n^i]) - \Xi_n([Y_{1^n}]) = \xi_{(1, \gamma_{\sigma_i})}^{1^n, \sigma_i} * \xi_{(1, \gamma_{\sigma_i})}^{\sigma_i, 1^n} - \tilde{\xi}_{(1,1)} \\ &= \tilde{\xi}_{(1, \gamma_{\sigma_i}/\gamma_{1^n}-1)} + \tilde{\xi}_{(s_i, \gamma_{\sigma_i}/\gamma_{1^n})} = \tilde{\xi}_{1, \frac{\Delta_{i,i+1}}{x_{i+1}-x_i}} + \tilde{\xi}_{s_i, 1 + \frac{\Delta_{i,i+1}}{x_{i+1}-x_i}}, \end{aligned}$$

where we have used the fact that $\gamma_{\sigma_i}/\gamma_{1^n} = (x_{i+1} - x_i + \Delta_{i,i+1})/(x_{i+1} - x_i)$ in the last equality. \square

Remark 4.14. It is possible to make this computation directly, without appealing to the results of Section 3. For this, one can first show that $Z_n^{\sigma_i}$ is smooth (in fact, it is isomorphic to a certain blowup of Y_{1^n}), and then use Lemma 1.6.

The algebra \mathcal{R}_n acts on $\mathbf{P}_n = H_{\mathbb{A}^1}^G(Y_{1^n})$ by Proposition 1.8. This is a subrepresentation of $\mathcal{S}_n \curvearrowright \mathbf{P}_n$, restricted to $\mathcal{R}_n \subset \mathcal{S}_n$. \mathbf{P}_n can be identified with a subspace in $(\mathbf{P}_n)_{\text{loc}}$, on which $\mathcal{R}_n^{\text{loc}}$ acts as in Section 1.4. Under this identification, we have

$$\begin{aligned} \Xi_n(P).h &= \tilde{\xi}_{(1,P)}.h = Ph\gamma/\gamma = Ph; \\ \Xi_n(\tau_i).h &= \left(\tilde{\xi}_{1, \frac{\Delta_{i,i+1}}{x_{i+1}-x_i}} + \tilde{\xi}_{s_i, 1 + \frac{\Delta_{i,i+1}}{x_{i+1}-x_i}} \right).h = \frac{\Delta_{i,i+1}}{x_{i+1}-x_i} h + \left(1 + \frac{\Delta_{i,i+1}}{x_{i+1}-x_i} \right) h^{s_i} \left(\frac{x_i - x_{i+1} + \Delta_{i,i+1}}{x_i - x_{i+1} - \Delta_{i,i+1}} \right) \\ &= h^{s_i} + \frac{\Delta_{i,i+1}}{x_{i+1}-x_i} (h - h^{s_i}) = (s_i - \Delta_{i,i+1} \partial_i)h. \end{aligned}$$

Theorem 4.15. *We have an isomorphism of algebras $\mathcal{R}_n^C \simeq \mathfrak{W}_n(H^*(C))$.*

Proof. It follows from the proof of Proposition 4.13 that $\tau_i = R_{1^n}^1(s_i) - 1$ in notations of Section 3.4. In particular, Theorem 3.10 implies that the algebra \mathcal{R}_n is generated by polynomial operators together with τ_i , $1 \leq i \leq n-1$. Both \mathcal{R}_n^C and $\mathfrak{W}_n(H^*(C))$ act on $\mathbf{P}_n(F)$, and the action of polynomial operators and τ_i 's is given by the same formulas. Since the polynomial representation $\mathbf{P}_n(F)$ is faithful for both algebras by Lemma 4.12 and Theorem 3.15, we deduce the desired isomorphism. \square

4.4. Affine zigzag algebra. Let us write out \mathcal{R}_n^C for $C = \mathbb{P}^1$. In this case $H^*(C) \simeq \mathbb{k}[c]/c^2$, and $\Delta_{i,j} = c_i + c_j$.

Definition 4.16. The *affine zigzag algebra* \mathfrak{Z}_n is the \mathbb{k} -algebra generated by elements $x_r, c_r, 1 \leq r \leq n$ and $\tau_k, 1 \leq k < n$ modulo the following relations:

$$\begin{aligned} x_r x_t &= x_t x_r, & x_r c_t &= c_t x_r, & c_r c_t &= c_t c_r, & c_r^2 &= 0; \\ \tau_k^2 &= 1, & \tau_k \tau_{k+1} \tau_k &= \tau_{k+1} \tau_k \tau_{k+1}, & \tau_k \tau_l &= \tau_l \tau_k \text{ if } |l - k| > 1; \\ \tau_k c_k &= c_{k+1} \tau_k, & \tau_k c_r &= c_r \tau_k \text{ if } r \neq k, k + 1; \\ \tau_k x_k - x_{k+1} \tau_k &= -c_k - c_{k+1} = x_k \tau_k - \tau_k x_{k+1}, & \tau_k x_r &= x_r \tau_k \text{ if } r \neq k, k + 1. \end{aligned}$$

Corollary 4.17. We have an isomorphism of algebras $\mathcal{R}_n^{\mathbb{P}^1} \simeq \mathfrak{Z}_n$.

Consider the following truncated polynomial ring:

$$\mathbf{P}_n = \mathbb{k}[x_1, \dots, x_n, c_1, \dots, c_n]/(c_1^2, \dots, c_n^2).$$

The following lemma is a special case of Lemmas 4.10 and 4.12.

Lemma 4.18. The affine zigzag algebra \mathfrak{Z}_n has the following basis:

$$\left\{ \tau_w x_1^{a_1} x_2^{a_2} \dots x_n^{a_n} c_1^{b_1} c_2^{b_2} \dots c_n^{b_n}; w \in \mathfrak{S}_n, a_r \in \mathbb{N}, b_r \in \{0, 1\} \right\}.$$

Furthermore, the algebra \mathfrak{Z}_n has a faithful representation in \mathbf{P}_n such that

- $x_r \in \mathfrak{Z}_n$ acts by multiplication by $x_r \in \mathbf{P}_n$,
- $c_r \in \mathfrak{Z}_n$ acts by multiplication by $c_r \in \mathbf{P}_n$,
- τ_k acts by $s_k - (c_k + c_{k+1})\partial_k$, where $\partial_k := \frac{1-s_k}{x_k - x_{k+1}}$ in notations of Lemma 4.12.

Remark 4.19. While the operator ∂_k is not well-defined on \mathbf{P}_n , the operator $(c_k + c_{k+1})\partial_k$ is. We could also write ∂_k^X instead of ∂_k as in Lemma 4.12.

4.5. Other examples. For $C = \mathbb{C}$ or \mathbb{C}^* , we have $Q_n \simeq \mathfrak{gl}_n$ and $Q_n \simeq GL_n$ respectively, equipped with the adjoint action of GL_n . We therefore recover Grothendieck-Springer resolution and its multiplicative version. Furthermore, let $C = E$ be an elliptic curve, and $\text{Bun}_{GL_n}^{0,ss}$ the stack of semistable GL_n -bundles of degree 0 on E . We have an equivalence of stacks $\mathcal{T}_n \simeq \text{Bun}_{GL_n}^{0,ss}$ essentially due to Atiyah [Ati57, FMW98]. Since it is compatible with embeddings of sheaves⁴, our map $\mathcal{F}_n \rightarrow \mathcal{T}_n$ produces the same Steinberg variety that appears in the context of elliptic Springer theory [BN15] (for $G = GL_n$).

5. INTEGRAL VERSION FOR \mathbb{P}^1

In this section we adapt some of the considerations above to homology with integral coefficients, when $C = \mathbb{P}^1$ is the projective line.

5.1. Integral homology of $\mathcal{T}_n(\mathbb{P}^1)$. The following analogue of Proposition 1.3 holds for cohomology with integer coefficients.

Proposition 5.1 ([HS09, Theorem 2.10]). *Let $G = GL_n$, $T \subset G$ a maximal torus and X a G -variety. If $H_T^*(X, \mathbb{Z})$ is torsion-free as an H_T -module, then we have an isomorphism $H_G^*(X, \mathbb{Z}) \simeq H_T^*(X, \mathbb{Z})^{\mathfrak{S}_n}$.*

In particular, we have $H_G^*(pt) = \mathbb{Z}[x_1, \dots, x_n]^{\mathfrak{S}_n}$. As for localization, Proposition 1.4 holds over any coefficient ring \mathbb{k} without \mathbb{Z} -torsion, in particular for $\mathbb{k} = \mathbb{Z}$.

The proof of Proposition 2.4 uses the decomposition theorem for perverse sheaves in an essential way, therefore only works for cohomology with coefficients in \mathbb{Q} . We expect that it remains true if we replace \mathbb{Q} by \mathbb{Z} . Here, we prove an analogous claim for the projective line. Let us denote the base curve of \mathcal{T}_n by superscript; thus, here we study $\mathcal{T}_n^{\mathbb{P}^1}$. We also denote by $\mathcal{T}_n^x \subset \mathcal{T}_n^C$ the substack of sheaves supported on $x \in C$. Note that we have

$$\mathcal{T}_n^C \simeq [\mathfrak{gl}_n/GL_n], \quad \mathcal{T}_n^x \simeq [\mathcal{N}_n/GL_n],$$

where $\mathcal{N}_n \subset GL_n$ is the nilpotent cone.

⁴that is, it is an equivalence of stacks, and not just of associated (algebraic) stacks in groupoids

Proposition 5.2. *Let $C = \mathbb{P}^1$. We have*

$$H^*(\mathcal{T}_n, \mathbb{Z}) \simeq \text{Sym}^n (H^*(\mathbb{P}^1, \mathbb{Z})[x]) = (\mathbb{Z}[x_1, \dots, x_n, c_1, \dots, c_n]/(c_1^2, \dots, c_n^2))^{\mathfrak{S}_n},$$

where $\deg x_i = \deg c_i = 2$.

Proof. We will drop the coefficient ring from notations, and write $H^*(-) = H^*(-, \mathbb{Z})$ throughout the proof for brevity. Let us decompose $\mathbb{P}^1 = \mathbb{C} \sqcup \{\infty\}$, where $\infty \in \mathbb{P}^1$ is the point at infinity (or any other point). This induces a stratification $S^n \mathbb{P}^1 = \bigsqcup S_i$, where $S_i \simeq S^{n-i} \mathbb{C}$ is the locally closed subvariety, consisting of tuples with exactly i occurrences of ∞ . Taking preimages under the support map, we get

$$(21) \quad \mathcal{T}_n = \bigsqcup_i \mathcal{T}_n^{i\infty}, \quad \mathcal{T}_n^{i\infty} = \text{supp}^{-1}(S_i).$$

Note that we have isomorphisms of moduli stacks $\mathcal{T}_n^{i\infty} \simeq \mathcal{T}_i^\infty \times \mathcal{T}_{n-i}^\mathbb{C}$. In particular, $\mathcal{T}_n^{i\infty} \simeq [(\mathcal{N}_i \times \mathfrak{gl}_{n-i})/G_n^{(i)}] \simeq [Q_n^{(i)}/G_n]$, where $G_n^{(i)} = GL_i \times GL_{n-i} \subset G_n$, and $Q_n^{(i)}$ can be seen either as $G_n \times_{G_n^{(i)}} (\mathcal{N}_i \times \mathfrak{gl}_{n-i})$, or a locally closed subvariety of Q_n with prescribed supports.

Recall that $Q_n^{T_n} = (\mathbb{P}^1)^n$. We have $Q_n^{T_n} \cap Q_n^{(i)} = \mathfrak{S}_n \times_{\mathfrak{S}_{(i, n-i)}} (\{\infty\}^i \times \mathbb{C}^{n-i})$, where \mathfrak{S}_n acts on $(\mathbb{P}^1)^n$ by permuting the factors. Note that $\mathcal{N}_i \times \mathfrak{gl}_{n-i}$ retracts to $\{\infty\}^i \times \mathbb{C}^{n-i}$. Since equivariant cohomology is homotopy invariant, the pullback map $H_{T_n}^*(\mathcal{N}_i \times \mathfrak{gl}_{n-i}) \rightarrow H_{T_n}^*(\{\infty\}^i \times \mathbb{C}^{n-i})$ is an isomorphism. In particular, we see that $H^*(\mathcal{T}_n^{i\infty}) = H_{G_n}^*(Q_n^{(i)}) = H_{G_n^{(i)}}^*(\mathcal{N}_i \times \mathfrak{gl}_{n-i})$ is even. Therefore the stratification (21) defines a filtration on $H_{G_n}^*(Q_n)$ with associated graded $\bigoplus_i H_{G_n}^*(Q_n^{(i)})$; the same holds if we replace G_n by T_n .

Let us introduce an auxiliary grading $\mathbf{P}_n = \bigoplus_k \mathbf{P}_n^{(k)}$ by the degree of polynomials in c_i 's. Since $c_i^2 = 0$ for any i , we see that $\mathbf{P}_n^{(k)} = 0$ for $k > n$. Moreover, it is clear that

$$\mathbf{P}_n^{(k)} = \bigoplus_{1 \leq i_1 < \dots < i_k \leq n} \mathbb{Z}[x_1, \dots, x_n] c_{i_1} \dots c_{i_k}.$$

We write $\mathbf{P}_n^{\leq k} = \bigoplus_{i=1}^k \mathbf{P}_n^{(i)}$; in particular, $\mathbf{P}_n^{\leq n} = \mathbf{P}_n$.

Consider the intersection $X_i = Q_n^{T_n} \cap Q_n^{(i)}$. By the computations above, we have $X_i = \mathfrak{S}_n \times_{\mathfrak{S}_{(k, n-k)}} (\{\infty\}^k \times \mathbb{C}^{n-k})$ and $\overline{X}_i = \bigcup_{\sigma \in \mathfrak{S}_n} \sigma(\{\infty\}^k \times (\mathbb{P}^1)^{n-k})$. Therefore $H_{T_n}^*(\overline{X}_k) = \mathbf{P}_n^{\leq k}$ for any k , and an easy induction argument identifies the short exact sequence $H_{T_n}^*(\overline{X}_{k-1}) \rightarrow H_{T_n}^*(\overline{X}_k) \rightarrow H_{T_n}^*(X_k)$ with $\mathbf{P}_n^{\leq k-1} \rightarrow \mathbf{P}_n^{\leq k} \rightarrow \mathbf{P}_n^{(k)}$. With this substitution, localization to T_n -fixed points gives us the following commutative diagrams:

$$\begin{array}{ccccc} H_{T_n}^*(\overline{Q_n^{(k-1)}}) & \hookrightarrow & H_{T_n}^*(\overline{Q_n^{(k)}}) & \twoheadrightarrow & H_{T_n}^*(Q_n^{(k)}) \\ \downarrow & & \downarrow & & \parallel \\ \mathbf{P}_n^{\leq k-1} & \hookrightarrow & \mathbf{P}_n^{\leq k} & \twoheadrightarrow & \mathbf{P}_n^{(k)} \end{array}$$

By an iterated application of 5-lemma for k descending from n to 1, pullback along the inclusion $(\mathbb{P}^1)^n \hookrightarrow Q_n$ induces an identification

$$H_{T_n}^*(Q_n) = \mathbf{P}_n = \mathbb{Z}[x_1, \dots, x_n, c_1, \dots, c_n]/(c_1^2, \dots, c_n^2).$$

Applying Proposition 1.3, we get $H^*(\mathcal{T}_n) = H_{T_n}^*(Q_n)^{\mathfrak{S}_n}$, and so we may conclude. \square

Remark 5.3. Note that the retractions in the proof above do not come from the global G_m -action on \mathbb{P}^1 , since for any such action either 0 or $\infty \in \mathbb{P}^1$ is a repellent point.

Applying universal coefficients, we obtain the following corollary.

Corollary 5.4. *For any ring \mathbb{k} , we have*

$$H^*(\mathcal{T}_n, \mathbb{k}) \simeq (\mathbb{k}[x_1, \dots, x_n, c_1, \dots, c_n])^{\mathfrak{S}_n},$$

where \mathfrak{S}_n acts by simultaneous permutation of the x_i 's and the c_i 's.

Let $\lambda \in \text{Comp}(n)$. Since $\mathcal{F}_\lambda \rightarrow \mathcal{T}_\lambda$ is a stack vector bundle, formula (11) shows that

$$H^*(\mathcal{F}_\lambda, \mathbb{Z}) \simeq (\mathbb{Z}[x_1, \dots, x_n, c_1, \dots, c_n]/(c_1^2, \dots, c_n^2))^{\mathfrak{S}_\lambda}.$$

Consider the composition

$$[(\mathbb{P}^1)^n/T_n] \rightarrow [Q_n/T_n] \rightarrow [Q_n/G_n],$$

where the first map is obtained from closed embedding $(\mathbb{P}^1)^n \hookrightarrow Q_n$, and the second map is given by restricting G_n -action on Q_n to T_n . This composition can be identified with the direct sum map

$$\bigoplus : (\mathcal{T}_1)^n \rightarrow \mathcal{T}_n, \quad (\mathcal{F}_1, \dots, \mathcal{F}_n) \mapsto \mathcal{F}_1 \oplus \dots \oplus \mathcal{F}_n.$$

Therefore, the isomorphism in Proposition 5.2 can be regarded as being induced from pullback along \bigoplus .

5.2. Tautological subring. Recall that we have the universal sheaf \mathcal{E} over $\mathcal{T}_n \times \mathbb{P}^1$. Applying Künneth decomposition to the Chern classes of \mathcal{E} , we write $c_i(\mathcal{E}) = c_{i,0} \otimes 1 + c_{i,1} \otimes p$, where $c_{i,j} \in H^{2(i-j)}(\mathcal{T}_n, \mathbb{Z})$, and $p \in H^2(\mathbb{P}^1, \mathbb{Z})$ is the class of a point.

Example 5.5. For $n = 1$, we have $H^*(\mathcal{T}_1, \mathbb{Z}) = \mathbb{Z}[x, c]/c^2$ and $\mathcal{E} = x\mathcal{O}_\Delta$. Note that under our identifications, $\Delta = c + p$. The total Chern class of \mathcal{E} is given by

$$(22) \quad c(\mathcal{E}) = c(x)/c(x\mathcal{O}(-\Delta)) = \frac{1+x}{1+x-\Delta} = 1 + (c+p) + \sum_{i \geq 1} (-x)^{i-1}((2ic-x)p - xc).$$

Comparing coefficients, we see that $c_{i,0} = (-x)^{i-1}c$ and $c_{i,1} = (-x)^{i-2}(2(i-1)c-x)$; in particular, $c = c_{1,0}$ and $x = 2c_{1,0} - c_{2,1}$.

Definition 5.6. The tautological ring $TH^*(\mathcal{T}_n, \mathbb{Z})$ is the subring of $H^*(\mathcal{T}_n, \mathbb{Z})$ generated by classes $c_{i,0}$, $c_{i,1}$, $i \in \mathbb{Z}_{>0}$.

If we work with \mathbb{Q} -coefficients, this definition is superfluous, since Künneth-Chern classes generate $H^*(\mathcal{T}_n, \mathbb{Q})$ as a ring; see [Hei12]. The following example shows that this is not the case over \mathbb{Z} .

Example 5.7. Let $n = 2$. By the universal property of \mathcal{E} , its pullback under \bigoplus is isomorphic to the direct sum of universal sheaves $\mathcal{E}_1 \oplus \mathcal{E}_2$. Since the total Chern class is functorial under pullbacks, we have $c(\mathcal{E}) = c(\mathcal{E}_1)c(\mathcal{E}_2)$. Using the formula (22), we obtain

$$c(\mathcal{E}) = (1 + (c_1 + c_2) + (c_1c_2 - c_1x_1 - c_2x_2) + \dots) \\ + p(2 + (3c_1 + 3c_2 - x_1 - x_2) + (x_1^2 + x_2^2 + 4(c_1c_2 - c_1x_1 - c_2x_2) - (c_1 + c_2)(x_1 + x_2)) + \dots).$$

As a consequence, we get the following expressions for the first few Künneth-Chern classes:

$$c_{1,0} = c_1 + c_2, \quad c_{2,0} = c_1c_2 - c_1x_1 - c_2x_2, \\ c_{2,1} = 3c_{1,0} - (x_1 + x_2), \quad c_{3,1} = x_1^2 + x_2^2 - (x_1 + x_2)c_{1,0} + 4c_{2,0}.$$

By definition, $TH^4(\mathcal{T}_2, \mathbb{Z})$ is spanned as a \mathbb{Z} -module by $c_{1,0}^2$, $c_{2,1}^2$, $c_{1,0}c_{2,1}$, $c_{2,0}$, $c_{3,1}$. Using the formulae above, it is easy to check that this sublattice neither contains c_1c_2 nor x_1x_2 ; however, we have $2c_1c_2 = c_{1,0}^2$ and $2x_1x_2 = 6c_{1,0}^2 - 5c_{1,0}c_{2,1} + c_{2,1}^2 - c_{3,1} + 4c_{2,0}$.

A similar computation shows that Künneth-Chern classes fail to generate $H^*(\mathcal{T}_n^C, \mathbb{Z})$, $n \geq 2$ for any smooth projective curve C , assuming that an analogue of Proposition 5.2 holds.

5.3. Homology of Steinberg is torsion-free. The proof of Lemma 2.9 works verbatim for $C = \mathbb{P}^1$ over any ring \mathbb{k} , except we need to replace purity considerations for splitting long exact sequences by parity of homology groups. The localization theorem can still be applied by Remark 1.5, since classes γ_λ are not zero divisors over any \mathbb{k} by formula (13). In particular, the localization map Ξ_n remains injective.

The rest of Sections 3 and 4, notably the proof of Theorem 3.10, goes through for any \mathbb{k} without changes. Note that even though some denominators appear in intermediate computations (essentially because of coefficients in (15)), all modules under consideration are free, so one can perform computations over $\mathbb{Z} \subset \mathbb{Q}$, obtain a result valid over \mathbb{Z} , and then change the base ring. One could get rid of denominators altogether, but it would render the notations even more cumbersome.

In particular, we obtain that Corollary 4.17 holds over any \mathbb{k} .

6. KLR ALGEBRAS OF QUIVERS

6.1. **KLR algebra.** Let $\Gamma = (I, H)$ be a quiver without loops, where I stands for the set of vertices, and H for the set of arrows. It comes equipped with source and target maps $s, t : H \rightarrow I$. For any $i, j \in I$, let h_{ij} be the number of arrows from i to j , and define

$$Q_{ij}(u, v) = \begin{cases} 0 & \text{if } i = j, \\ (u - v)^{h_{ij}}(v - u)^{h_{ji}} & \text{otherwise.} \end{cases}$$

Let $\alpha = (n_i)_{i \in I} \in \mathbb{Z}_{\geq 0}^I$ be a dimension vector. It can be alternatively written as a sum $\alpha = \sum_{i \in I} n_i \alpha_i$, where $\alpha_i = (\delta_{ij})_{j \in I}$, $i \in I$. For a dimension vector α , we define $|\alpha| := \sum_{i \in I} n_i$ and

$$I^\alpha = \left\{ \mathbf{i} = (i_1, i_2, \dots, i_{|\alpha|}) \in I^{|\alpha|} : \sum_{r=1}^{|\alpha|} \alpha_{i_r} = \alpha \right\}.$$

We will also make use of the following refinement of I^α :

$$I^{(\alpha)} = \left\{ \mathbf{i} = (i_1^{(a_1)}, i_2^{(a_2)}, \dots, i_k^{(a_k)}) : a_r \in \mathbb{Z}_{>0}, \sum_{r=1}^{|\alpha|} a_r \alpha_{i_r} = \alpha \right\},$$

where we treat $i^{(a)}$ as a formal symbol corresponding to divided powers (see Section 6.4). To any $\mathbf{i} \in I^{(\alpha)}$ we can associate $\bar{\mathbf{i}} = (i_1^{a_1}, i_2^{a_2}, \dots, i_k^{a_k}) \in I^\alpha$, obtained by replacing each divided power $i_r^{(a_r)}$ with a_r consecutive copies of i_r . For each $\mathbf{i} = (i_1^{(a_1)}, i_2^{(a_2)}, \dots, i_k^{(a_k)}) \in I^{(\alpha)}$, let $\mathfrak{S}_{\mathbf{i}} = \mathfrak{S}_{a_1} \times \mathfrak{S}_{a_2} \times \dots \times \mathfrak{S}_{a_k}$ be the subgroup of $\mathfrak{S}_{|\alpha|}$ associated to $(a_1, \dots, a_k) \in \text{Comp}(|\alpha|)$.

Definition 6.1. A *KLR diagram* of weight α is a planar diagram containing $|\alpha|$ strands such that:

- the strands connect $|\alpha|$ points on one horizontal line with $|\alpha|$ points on another horizontal line, each strand goes from bottom to top;
- each strand is labeled by an element of I ;
- for each $i \in I$, there are n_i strands with label i ;
- two strands are allowed to cross, and there are no triple-crossings;
- a piece of a strand is allowed to carry a dot, a dot cannot collide with a crossing.

We consider KLR diagrams modulo isotopies. In particular, a dot is allowed to move freely along the strand, as long as it doesn't slide past a crossing. In what follows, we will denote the crossing between r -th and $(r + 1)$ -th strand by ψ_r , and the diagram with a single dot on r -th strand by y_r .

Definition 6.2. The *KLR algebra* $R(\alpha)$ is the \mathbb{k} -algebra generated by KLR diagrams of weight α modulo the local relations below:

$$(23) \quad \begin{array}{c} \text{diagram with dot on strand } i \text{ crossing strand } j \\ \text{diagram with dot on strand } j \text{ crossing strand } i \end{array} = \text{diagram with dot on strand } j \text{ crossing strand } i \quad \text{if } i \neq j,$$

$$(24) \quad \begin{array}{c} \text{diagram with dot on strand } i \text{ crossing strand } i \\ \text{diagram with dot on strand } i \text{ crossing strand } i \end{array} = \begin{array}{c} \text{diagram with dot on strand } i \text{ crossing strand } i \\ \text{diagram with dot on strand } i \text{ crossing strand } i \end{array} - \begin{array}{c} | \\ | \end{array}, \quad \begin{array}{c} \text{diagram with dot on strand } i \text{ crossing strand } i \\ \text{diagram with dot on strand } i \text{ crossing strand } i \end{array} = \begin{array}{c} \text{diagram with dot on strand } i \text{ crossing strand } i \\ \text{diagram with dot on strand } i \text{ crossing strand } i \end{array} - \begin{array}{c} | \\ | \end{array},$$

$$(25) \quad \begin{array}{c} \text{diagram with strand } i \text{ crossing strand } j \\ \text{diagram with strand } i \text{ crossing strand } j \end{array} = \boxed{Q_{ij}(y_1, y_2)} \quad \text{if } i \neq j, \quad \begin{array}{c} \text{diagram with strand } i \text{ crossing strand } i \\ \text{diagram with strand } i \text{ crossing strand } i \end{array} = 0,$$

$$(26) \quad \begin{array}{c} \text{diagram with strand } i \text{ crossing strand } j \text{ crossing strand } k \\ \text{diagram with strand } i \text{ crossing strand } j \text{ crossing strand } k \end{array} = \begin{array}{c} \text{diagram with strand } i \text{ crossing strand } j \text{ crossing strand } k \\ \text{diagram with strand } i \text{ crossing strand } j \text{ crossing strand } k \end{array} \quad \text{unless } i = k \neq j,$$

$$(27) \quad \begin{array}{c} \diagup \quad \diagdown \\ \diagdown \quad \diagup \\ i \quad j \quad i \end{array} = \begin{array}{c} \diagdown \quad \diagup \\ \diagup \quad \diagdown \\ i \quad j \quad i \end{array} - \boxed{\frac{Q_{ij}(y_3, y_2) - Q_{ij}(y_1, y_2)}{y_3 - y_1}} \quad \text{if } i \neq j.$$

The multiplication is given by vertical concatenation; we impose the concatenation of strands with different labels to be zero.

Remark 6.3. We will be chiefly interested in KLR algebras for the Kronecker quiver $\Gamma = (1 \rightrightarrows 0)$. In this case we have

$$Q_{01}(u, v) = Q_{10}(u, v) = (u - v)^2, \quad \frac{Q_{01}(y_3, y_2) - Q_{01}(y_1, y_2)}{y_3 - y_1} = y_1 - 2y_2 + y_3.$$

For each $i \in I^\alpha$ we have an idempotent 1_i , given by a diagram consisting of $|\alpha|$ vertical strands, with the r -th strand labeled by i_r for any r . The algebra $R(\alpha)$ is clearly generated as a \mathbb{k} -algebra by these idempotents, together with single crossings and dots. Diagrammatically, we have

$$y_r 1_i = \begin{array}{c} | \quad \dots \quad | \quad \dots \quad | \\ i_1 \quad \dots \quad i_r \quad \dots \quad i_{|\alpha|} \end{array}, \quad \psi_r 1_i = \begin{array}{c} | \quad \dots \quad \times \quad \dots \quad | \\ i_1 \quad \dots \quad i_r \quad i_{r+1} \quad \dots \quad i_{|\alpha|} \end{array},$$

and

$$y_r = \sum_{i \in I^\alpha} y_r 1_i, \quad \psi_r = \sum_{i \in I^\alpha} \psi_r 1_i.$$

For example, relations (23-24) take the following form:

$$y_r \psi_r = \psi_r y_{r+1} - \sum_{i \in I^\alpha, i_r = i_{r+1}} 1_i, \quad \psi_r y_r = y_{r+1} \psi_r - \sum_{i \in I^\alpha, i_r = i_{r+1}} 1_i.$$

6.2. Polynomial representation of $R(\alpha)$. Let $m = |\alpha|$, and define $\text{Pol}_m = \mathbb{k}[y_1, \dots, y_m]$. Let further Pol_α be the direct sum of I^α -worth copies of Pol_m . We write $\text{Pol}_\alpha = \bigoplus_{i \in I^\alpha} \text{Pol}_m 1_i$, where 1_i is the idempotent projecting to the i -th copy.

Lemma 6.4 ([Rou08, §3.2.2]). *The algebra $R(\alpha)$ has a faithful representation on the vector space Pol_α , such that $1_i \in R(\alpha)$ acts by the projector 1_i , $y_r \in R(\alpha)$ acts by multiplication by y_r , and for any $f \in \text{Pol}_m$ we have*

$$(28) \quad \psi_r \cdot f 1_i = \begin{cases} -\partial_r(f) 1_i & \text{if } i_r = i_{r+1}, \\ P_{i_r, i_{r+1}}(y_r, y_{r+1}) s_r(f) 1_{s_r(i)} & \text{else.} \end{cases}$$

Here $P_{ij}(u, v) = (u - v)^{h_{ij}}$, and $\partial_r = \frac{1 - s_r}{y_r - y_{r+1}}$ is the Demazure operator.

6.3. Geometric construction of KLR algebras. Fix a dimension vector $\alpha = \sum_{i \in I} n_i \alpha_i$ with $|\alpha| = m$. Let V be an I -graded complex vector space of dimension α , that is a complex vector space with decomposition $V = \bigoplus_{i \in I} V_i$, such that $\dim V_i = n_i$. Consider the variety $E_\alpha = \bigoplus_{h \in H} \text{Hom}(V_{s(h)}, V_{t(h)})$, on which we have a natural action of $G_\alpha = \prod_{i \in I} GL(V_i)$. For $\mathbf{i} = (i_1^{(a_1)}, i_2^{(a_2)}, \dots, i_k^{(a_k)}) \in I^{(\alpha)}$, let \mathbf{F}_i be the variety of flags in V

$$\varphi = (\{0\} = V^0 \subset V^1 \subset \dots \subset V^k = V),$$

which are homogeneous with respect to the decomposition $V = \bigoplus_{i \in I} V_i$, and for each $1 \leq r \leq k$ the graded dimension of V^r / V^{r-1} is equal to $a_r \alpha_{i_r}$. Further, let $\tilde{\mathbf{F}}_i$ be the following variety of pairs:

$$\tilde{\mathbf{F}}_i = \{(x, \varphi) \in E_\alpha \times \mathbf{F}_i : x(V^r) \subset V^r, 0 \leq r \leq k\}.$$

Analogously to Section 2.1, we have an isomorphism $H_{G_\alpha}^*(\mathbf{F}_i) \simeq \text{Pol}_m^{\mathbb{S}_i}$, where for each $r \in [1, k]$ the elements $y_{a_1 + \dots + a_{r-1} + 1}, y_{a_1 + \dots + a_{r-1} + 2}, \dots, y_{a_1 + \dots + a_r}$ are the Chern roots of the vector bundle V^r / V^{r-1} . Since $\tilde{\mathbf{F}}_i$ is a vector bundle over \mathbf{F}_i , we also have $H_{G_\alpha}^*(\tilde{\mathbf{F}}_i) \simeq \text{Pol}_m^{\mathbb{S}_i}$.

We also denote $\mathbf{F}_\alpha = \prod_{i \in I^\alpha} \mathbf{F}_i$, $\tilde{\mathbf{F}}_\alpha = \prod_{i \in I^\alpha} \tilde{\mathbf{F}}_i$. Let $\pi_\alpha : \tilde{\mathbf{F}}_\alpha \rightarrow E_\alpha$ be the natural projection, that is $\pi_\alpha(x, \varphi) = x$, and consider the corresponding fiber product $\mathbf{Z}_\alpha = \tilde{\mathbf{F}}_\alpha \times_{E_\alpha} \tilde{\mathbf{F}}_\alpha$. We have

$$\mathbf{Z}_\alpha = \prod_{i,j \in I^\alpha} \mathbf{Z}_{i,j} = \prod_{i,j \in I^\alpha} \tilde{\mathbf{F}}_i \times_{E_\alpha} \tilde{\mathbf{F}}_j.$$

In other words, $\mathbf{Z}_{i,j}$ is the variety of triples $(x, \varphi_1, \varphi_2) \in E_\alpha \times \mathbf{F}_i \times \mathbf{F}_j$, such that x preserves both φ_1 and φ_2 .

Remark 6.5. For now, we only consider $\mathbf{i} \in I^\alpha$; however, the definition of $\mathbf{Z}_{i,j}$ makes sense for $\mathbf{i}, \mathbf{j} \in I^{(\alpha)}$ as well. We will make use of these more general varieties in Section 6.5.

By Proposition 1.8, we have an algebra structure on $\mathcal{A}(\pi_\alpha) = H_{G_\alpha}^*(\mathbf{Z}_\alpha, \mathbb{k})$, and an action of it on $H_{G_\alpha}^*(\tilde{\mathbf{F}}_\alpha, \mathbb{k})$. The following statement is proved in [VV11, Rou08] for \mathbb{k} a field of characteristic zero, and in [Mak15] for an arbitrary ring \mathbb{k} of finite global dimension.

Proposition 6.6. *The KLR algebra $R(\alpha)$ is isomorphic to the convolution algebra $H_{G_\alpha}^*(\mathbf{Z}_\alpha)$. Moreover, the representation Pol_α of $R(\alpha)$ is isomorphic to the representation $H_{G_\alpha}^*(\tilde{\mathbf{F}}_\alpha)$ of $H_{G_\alpha}^*(\mathbf{Z}_\alpha)$.*

Remark 6.7. The idempotents $1_i \in R(\alpha)$ correspond to different connected components. Namely, we have

$$H_{G_\alpha}^*(\mathbf{Z}_{i,j}) \simeq 1_i R(\alpha) 1_j, \quad H_{G_\alpha}^*(\tilde{\mathbf{F}}_i) \simeq \text{Pol}_m 1_i.$$

6.4. Divided powers. The algebra $R(n\alpha_i)$ is known as the *nil-Hecke algebra* of rank n . Let $w = s_{i_1} \dots s_{i_r}$ be a reduced decomposition of $w \in \mathfrak{S}_n$. Relation (26) implies that the product $\psi_{i_1} \dots \psi_{i_r}$ is independent of the decomposition above. We denote this element of $R(n\alpha_i)$ by ψ_w .

Let $w_{0,n}$ be the longest element in \mathfrak{S}_n . Define $y_{0,n} := y_n^{n-1} y_{n-1}^{n-2} \dots y_3^2 y_2$, and $1_{i^{(n)}} := \psi_{w_{0,n}} y_{0,n} \in R(n\alpha_i)$. It is easy to check that $\psi_{w_{0,n}} y_{0,n} \psi_{w_{0,n}} = \psi_{w_{0,n}}$, which implies that the element $1_{i^{(n)}}$ is an idempotent. We call $1_{i^{(n)}}$ the *divided difference idempotent*. Note that it acts on $\text{Pol}_{n\alpha_i} \simeq \text{Pol}_n$ as the projector to symmetric polynomials.

Let $\alpha \in \mathbb{Z}_{>0}^I$ be as in Section 6.3. For each $\mathbf{i} = (i_1^{(a_1)}, i_2^{(a_2)}, \dots, i_k^{(a_k)}) \in I^{(\alpha)}$, let $w_{0,i}$ be the maximal length element in \mathfrak{S}_i , and define the following elements in $R(a_1\alpha_{i_1}) \otimes \dots \otimes R(a_k\alpha_{i_k}) \subset R(\alpha)$:

$$1_{\mathbf{i}} := 1_{i_1^{(a_1)}} \otimes 1_{i_2^{(a_2)}} \otimes \dots \otimes 1_{i_r^{(a_k)}}, \quad y_{\mathbf{i}} := y_{0,a_1} \otimes y_{0,a_2} \otimes \dots \otimes y_{0,a_k}.$$

The definitions in nil-Hecke algebra imply that $y_{\mathbf{i}} = y_{\mathbf{i}} 1_{\mathbf{i}}$ and $1_{\mathbf{i}} = \psi_{w_{0,i}} y_{\mathbf{i}}$.

In graphical calculus we draw divided power idempotents as boxes. For example, the idempotent $1_{\mathbf{i}}$ with $\mathbf{i} = (i_1^{(a_1)}, i_2^{(a_2)}, \dots, i_k^{(a_k)})$ is depicted as follows (we have a_r strands with label i_r):

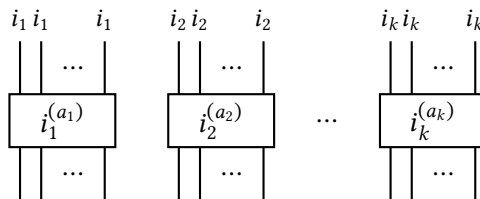

For each $w \in \mathfrak{S}_m$ fix a reduced decomposition $w = s_{r_1} \dots s_{r_k}$, and let

$$\psi_w 1_{\mathbf{i}} = \psi_{r_1} \dots \psi_{r_k} 1_{\mathbf{i}}, \quad \psi_w = \sum_{\mathbf{i} \in I^\alpha} \psi_w 1_{\mathbf{i}}.$$

Unlike the case of the nil-Hecke algebra, this definition of $\psi_w 1_{\mathbf{i}}$ does depend on the choice of the decomposition. Note that we allow to choose different reduced decompositions of the same w for different \mathbf{i} .

For any $\mathbf{i} = (i_1, i_2, \dots, i_m) \in I^m$ and $w \in \mathfrak{S}_m$, set $w(\mathbf{i}) = (i_{w^{-1}(1)}, i_{w^{-1}(2)}, \dots, i_{w^{-1}(m)})$. For any $\mathbf{i}, \mathbf{j} \in I^\alpha$, let $\mathfrak{J}\mathfrak{S}^{\mathbf{i}} = \{w \in \mathfrak{S}_m : w(\mathbf{i}) = \mathbf{j}\}$. More generally if $\mathbf{i}, \mathbf{j} \in I^{(\alpha)}$, define $\mathfrak{J}\mathfrak{S}^{\mathbf{i}}$ to be the set of shortest representatives of cosets in $\mathfrak{S}_j \backslash \mathfrak{J}\mathfrak{S}^{\mathbf{i}} / \mathfrak{S}_i$. The following lemma is proved in [Rou08, Theorem 3.7], see also [KL09, Theorem 2.5].

Lemma 6.8. *For any $\mathbf{i}, \mathbf{j} \in I^\alpha$, each of the following two sets forms a basis of $1_{\mathbf{j}} R(\alpha) 1_{\mathbf{i}}$:*

$$\{y_1^{a_1} y_2^{a_2} \dots y_n^{a_n} \psi_w 1_{\mathbf{i}}; w \in \mathfrak{J}\mathfrak{S}^{\mathbf{i}}, a_r \in \mathbb{Z}_{\geq 0}\}, \quad \{\psi_w y_1^{a_1} y_2^{a_2} \dots y_n^{a_n} 1_{\mathbf{i}}; w \in \mathfrak{J}\mathfrak{S}^{\mathbf{i}}, a_r \in \mathbb{Z}_{\geq 0}\}.$$

Above we described some bases in $1_j R(\alpha) 1_i$ for $\mathbf{i}, \mathbf{j} \in I^\alpha$. However, we will need a version of Lemma 6.8 which allows \mathbf{i}, \mathbf{j} to lie in $I^{(\alpha)}$. Let us begin with some preparations. For each $\mathbf{i} = (i_1^{(a_1)}, i_2^{(a_2)}, \dots, i_k^{(a_k)}) \in I^{(\alpha)}$ and $x \in \mathfrak{S}_k$, let

$$x^{-1}(\mathbf{i}) = \left(i_{x(1)}^{(a_{x(1)})}, i_{x(2)}^{(a_{x(2)})}, \dots, i_{x(k)}^{(a_{x(k)})} \right).$$

Definition 6.9. Let $\mathbf{i}, \mathbf{j} \in I^{(\alpha)}$, $\mathbf{i} = (i_1^{(a_1)}, i_2^{(a_2)}, \dots, i_k^{(a_k)})$, $\mathbf{j} = (j_1^{(b_1)}, j_2^{(b_2)}, \dots, j_k^{(b_k)})$. We say that \mathbf{j} is a *permutation* of \mathbf{i} if there exists $x \in \mathfrak{S}_k$ such that $x(\mathbf{i}) = \mathbf{j}$. Each such x induces a permutation $w \in \mathfrak{J}\mathfrak{S}^{\mathbf{i}}$.

For $\mathbf{j}, \mathbf{j}' \in I^{(\alpha)}$, we say that \mathbf{j}' is a *split* of \mathbf{j} if we have $\bar{\mathbf{j}} = \bar{\mathbf{j}'}$ and $\mathfrak{S}_{\mathbf{j}'} \subset \mathfrak{S}_{\mathbf{j}}$. In this case, let $w_{0, \mathbf{j}, \mathbf{j}'}$ be the longest element in $\mathfrak{S}_{\mathbf{j}} \cap \mathfrak{J}\mathfrak{S}^{\mathbf{j}'}$. For any $\mathbf{i}, \mathbf{j} \in I^{(\alpha)}$ and $w \in \mathfrak{J}\mathfrak{S}^{\mathbf{i}}$, there exist unique $\mathbf{i}', \mathbf{j}' \in I^{(\alpha)}$ such that \mathbf{i}' is a split of \mathbf{i} , \mathbf{j}' is a split of \mathbf{j} , \mathbf{j}' is a permutation of \mathbf{i}' and $\mathfrak{S}_{\mathbf{j}'} = w\mathfrak{S}_{\mathbf{i}'}w^{-1} \cap \mathfrak{S}_{\mathbf{j}}$, $\mathfrak{S}_{\mathbf{i}'} = w^{-1}\mathfrak{S}_{\mathbf{j}'}w \cap \mathfrak{S}_{\mathbf{i}}$ (compare this to the notation in (17)). Fix a basis $B_{\mathbf{i}'}$ of $\text{Pol}_m^{\mathfrak{S}_{\mathbf{i}'}}$; note that $B_{\mathbf{j}'} = w(B_{\mathbf{i}'})$ is a basis of $\text{Pol}_m^{\mathfrak{S}_{\mathbf{j}'}}$.

Lemma 6.10. For each $\mathbf{i}, \mathbf{j} \in I^{(\alpha)}$, each of the following two sets forms a basis of $1_j R(n\delta) 1_i$:

$$(29) \quad \{\psi_{w_{0, \mathbf{j}, \mathbf{j}'}} P \psi_w 1_{\mathbf{i}}; w \in \mathfrak{J}\mathfrak{S}^{\mathbf{i}}, P \in B_{\mathbf{j}'}\}, \quad \{\psi_{w_{0, \mathbf{j}, \mathbf{j}'}} \psi_w P 1_{\mathbf{i}}; w \in \mathfrak{J}\mathfrak{S}^{\mathbf{i}}, P \in B_{\mathbf{j}'}\}.$$

It is possible to give an algebraic proof of the lemma above. In order to be more concise, we give a geometric proof at the end of Section 6.5 instead.

6.5. Geometric construction of divided powers. We begin with the following lemma.

Lemma 6.11. For $x \in R(\alpha)$ and $\mathbf{i} \in I^{(\alpha)}$, we have $1_{\mathbf{i}} x = x$ if and only if the image of the action of x on Pol_α is contained in $\text{Pol}_m^{\mathfrak{S}_{\mathbf{i}}} 1_{\bar{\mathbf{i}}}$:

Proof. Follows from the fact that $1_{\mathbf{i}}$ acts on Pol_α as a projector to $\text{Pol}_m^{\mathfrak{S}_{\mathbf{i}}} 1_{\bar{\mathbf{i}}}$. \square

Let us consider the following divided power versions of the KLR algebra $R(\alpha)$ and related geometric objects:

$$\widehat{R}(\alpha) = \bigoplus_{\mathbf{i}, \mathbf{j} \in I^{(\alpha)}} 1_{\mathbf{i}} R(\alpha) 1_{\mathbf{j}}, \quad \widetilde{\mathbf{F}}_{(\alpha)} = \prod_{\mathbf{i} \in I^{(\alpha)}} \widetilde{\mathbf{F}}_{\mathbf{i}}, \quad \mathbf{Z}_{(\alpha)} = \prod_{\mathbf{i}, \mathbf{j} \in I^{(\alpha)}} \mathbf{Z}_{\mathbf{i}, \mathbf{j}}.$$

Similarly to Pol_α , let us also consider the vector space $\text{Pol}_{(\alpha)} = \bigoplus_{\mathbf{i} \in I^{(\alpha)}} \text{Pol}_m^{\mathfrak{S}_{\mathbf{i}}} 1_{\mathbf{i}}$, where $1_{\mathbf{i}}$ is the projector to the direct summand labeled by \mathbf{i} . For any $\mathbf{i}, \mathbf{j} \in I^{(\alpha)}$, each element of $1_{\mathbf{i}} R(\alpha) 1_{\mathbf{j}}$ yields a linear map $\text{Pol}_m 1_{\mathbf{j}} \rightarrow \text{Pol}_m 1_{\bar{\mathbf{i}}}$ by Lemma 6.4. In particular, each element of $1_{\mathbf{i}} R(\alpha) 1_{\mathbf{j}} \subset 1_{\bar{\mathbf{i}}} R(\alpha) 1_{\mathbf{j}}$ yields a linear map $\text{Pol}_m^{\mathfrak{S}_{\mathbf{j}}} 1_{\mathbf{j}} \rightarrow \text{Pol}_m^{\mathfrak{S}_{\mathbf{i}}} 1_{\bar{\mathbf{i}}}$ by Lemma 6.11. This defines an action of $\widehat{R}(\alpha)$ on $\text{Pol}_{(\alpha)}$. Moreover, since $R(\alpha)$ acts faithfully on Pol_α , the representation $\text{Pol}_{(\alpha)}$ of $\widehat{R}(\alpha)$ is faithful as well.

On the other hand, $H_{G_\alpha}^*(\mathbf{Z}_{(\alpha)})$ is a convolution algebra, which acts on $H_{G_\alpha}^*(\widetilde{\mathbf{F}}_{(\alpha)})$. We have an identification of vector spaces

$$H_{G_\alpha}^*(\widetilde{\mathbf{F}}_{(\alpha)}) = \bigoplus_{\mathbf{i} \in I^{(\alpha)}} H_{G_\alpha}^*(\widetilde{\mathbf{F}}_{\mathbf{i}}) = \bigoplus_{\mathbf{i} \in I^{(\alpha)}} \text{Pol}_m^{\mathfrak{S}_{\mathbf{i}}} 1_{\mathbf{i}} = \text{Pol}_{(\alpha)}.$$

We will upgrade this to an isomorphism of $\widehat{R}(\alpha)$ -modules in Proposition 6.16.

Note that for any $\mathbf{i} \in I^{(\alpha)}$, we have a closed embedding

$$\widetilde{\mathbf{F}}_{\bar{\mathbf{i}}} = \widetilde{\mathbf{F}}_{\mathbf{i}} \times_{\widetilde{\mathbf{F}}_{\mathbf{i}}} \widetilde{\mathbf{F}}_{\bar{\mathbf{i}}} \hookrightarrow \widetilde{\mathbf{F}}_{\mathbf{i}} \times_{E_\alpha} \widetilde{\mathbf{F}}_{\bar{\mathbf{i}}} = \mathbf{Z}_{\mathbf{i}, \bar{\mathbf{i}}}.$$

Consider the corresponding classes in the algebra $H_{G_\alpha}^*(\mathbf{Z}_{(\alpha)})$:

$$z_{\mathbf{i}, \bar{\mathbf{i}}} = [\widetilde{\mathbf{F}}_{\mathbf{i}} \times_{\widetilde{\mathbf{F}}_{\mathbf{i}}} \widetilde{\mathbf{F}}_{\bar{\mathbf{i}}}] \in H_{G_\alpha}^*(\mathbf{Z}_{\mathbf{i}, \bar{\mathbf{i}}}) \subset H_{G_\alpha}^*(\mathbf{Z}_{(\alpha)}), \quad z_{\mathbf{i}, \mathbf{i}} = [\widetilde{\mathbf{F}}_{\mathbf{i}} \times_{\widetilde{\mathbf{F}}_{\mathbf{i}}} \widetilde{\mathbf{F}}_{\mathbf{i}}] \in H_{G_\alpha}^*(\mathbf{Z}_{\mathbf{i}, \mathbf{i}}) \subset H_{G_\alpha}^*(\mathbf{Z}_{(\alpha)}).$$

Lemma 6.12. The map $H_{G_\alpha}^*(\mathbf{Z}_{\mathbf{i}, \mathbf{j}}) \rightarrow H_{G_\alpha}^*(\mathbf{Z}_{\mathbf{i}, \bar{\mathbf{j}}})$, $x \mapsto z_{\mathbf{i}, \mathbf{i}} x z_{\mathbf{j}, \bar{\mathbf{j}}}$ is injective.

Proof. By the definition of the convolution product, this map is given by the following correspondence:

$$\mathbf{Z}_{\mathbf{i}, \mathbf{j}} \xleftarrow{p} \widetilde{\mathbf{F}}_{\mathbf{i}} \times_{\widetilde{\mathbf{F}}_{\mathbf{i}}} \mathbf{Z}_{\mathbf{i}, \mathbf{j}} \times_{\widetilde{\mathbf{F}}_{\mathbf{j}}} \widetilde{\mathbf{F}}_{\bar{\mathbf{j}}} \xrightarrow{q} \mathbf{Z}_{\mathbf{i}, \bar{\mathbf{j}}}, \quad z_{\mathbf{i}, \mathbf{i}} x z_{\mathbf{j}, \bar{\mathbf{j}}} = q_* p^!(x).$$

Since $\mathbf{Z}_{\mathbf{i}, \mathbf{j}} = \widetilde{\mathbf{F}}_{\mathbf{i}} \times_{E_\alpha} \widetilde{\mathbf{F}}_{\mathbf{j}}$, it is clear that the map q is an isomorphism. Note that $\widetilde{\mathbf{F}}_{\bar{\mathbf{i}}} \rightarrow \widetilde{\mathbf{F}}_{\mathbf{i}}$ is a locally trivial fibration in partial flag varieties for any \mathbf{i} . In particular, p is a locally trivial fibration in products of

partial flag varieties, and it is straightforward to verify that $p^! = p^*$. Moreover, p^* is injective by an iterated application of projective bundle theorem.

Putting everything together, the map $x \mapsto z_{\bar{i},i} x z_{\bar{j},j}$ is identified with an injective map p^* . \square

Corollary 6.13. *The representation $H_{G_\alpha}^*(\tilde{\mathbf{F}}_\alpha)$ of $H_{G_\alpha}^*(\mathbf{Z}_\alpha)$ is faithful.*

Proof. Suppose that $x \in H_{G_\alpha}^*(\mathbf{Z}_{i,j})$ acts on $H_{G_\alpha}^*(\tilde{\mathbf{F}}_\alpha)$ by zero. Then the element $z_{\bar{i},i} x z_{\bar{j},j} \in \mathbf{Z}_{\bar{i},\bar{j}}$ acts on $H_{G_\alpha}^*(\tilde{\mathbf{F}}_\alpha)$ by zero. Since the action of $R(\alpha)$ on $H_{G_\alpha}^*(\tilde{\mathbf{F}}_\alpha)$ is faithful, we have $z_{\bar{i},i} x z_{\bar{j},j} = 0$, and the lemma above implies that $x = 0$. \square

Recall that $w_{0,i}$ is the maximal length element in \mathfrak{S}_i . We view the polynomial y_i , defined in Section 6.4, as an element of $H_{G_\alpha}^*(\mathbf{Z}_{\bar{i},\bar{i}})$.

Lemma 6.14. (a) *The element $z_{\bar{i},\bar{i}}$ acts on Pol_α by*

$$z_{\bar{i},\bar{i}} : \text{Pol}_m 1_{\bar{i}} \rightarrow \text{Pol}_m^{\mathfrak{S}_i} 1_i, \quad P 1_{\bar{i}} \mapsto (-1)^{\ell(w_{0,i})} \partial_{w_{0,i}}(P) 1_{\bar{i}};$$

(b) *the element $z_{\bar{i},i}$ acts on Pol_α by*

$$z_{\bar{i},i} : \text{Pol}_m^{\mathfrak{S}_i} 1_i \rightarrow \text{Pol}_m 1_{\bar{i}}, \quad P 1_{\bar{i}} \mapsto P 1_i.$$

Proof. See [Prz19, Theorem 4.7]; the proof there is similar to our Theorem 3.15. \square

Corollary 6.15. (a) *We have $z_{\bar{i},\bar{i}} y_i z_{\bar{i},i} = 1$ in $H_{G_\alpha}^*(\mathbf{Z}_{i,i})$;*

(b) *we have $z_{\bar{i},i} z_{\bar{i},\bar{i}} y_i = 1_i$ in $1_{\bar{i}} R(\alpha) 1_{\bar{i}} = H_{G_\alpha}^*(\mathbf{Z}_{\bar{i},\bar{i}})$.*

Proof. It suffices to check these equalities on polynomial representations, where they follow from Lemma 6.14. \square

The following statement is the divided power version of Proposition 6.6.

Proposition 6.16. (a) *There exists an isomorphism of algebras $H_{G_\alpha}^*(\mathbf{Z}_\alpha) \simeq \widehat{R}(\alpha)$;*

(b) *this isomorphism restricts to $H_{G_\alpha}^*(\mathbf{Z}_{i,j}) \simeq 1_i R(\alpha) 1_j$ for each $i, j \in I^{(\alpha)}$;*

(c) *the $H_{G_\alpha}^*(\mathbf{Z}_\alpha)$ -action on $H_{G_\alpha}^*(\tilde{\mathbf{F}}_\alpha)$ gets identified with the $\widehat{R}(\alpha)$ -action on Pol_α .*

Proof. For each $i, j \in I^{(\alpha)}$, consider the maps

$$\begin{aligned} p_{i,j} : H_{G_\alpha}^*(\mathbf{Z}_{i,j}) &\rightarrow H_{G_\alpha}^*(\mathbf{Z}_{\bar{i},\bar{j}}), & x &\mapsto z_{\bar{i},i} x z_{\bar{j},j} y_j, \\ q_{i,j} : H_{G_\alpha}^*(\mathbf{Z}_{\bar{i},\bar{j}}) &\rightarrow H_{G_\alpha}^*(\mathbf{Z}_{i,j}), & x &\mapsto z_{\bar{i},i} y_i x z_{\bar{j},j}. \end{aligned}$$

It follows from Corollary 6.15.(a) that $q_{i,j} \circ p_{i,j}$ is the identity of $H_{G_\alpha}^*(\mathbf{Z}_{i,j})$. This allows to identify $H_{G_\alpha}^*(\mathbf{Z}_{i,j})$ with a vector subspace of $H_{G_\alpha}^*(\mathbf{Z}_{\bar{i},\bar{j}})$. Moreover, $p_{i,j} \circ q_{i,j}$ is the projector to the image of $H_{G_\alpha}^*(\mathbf{Z}_{i,j})$ in $H_{G_\alpha}^*(\mathbf{Z}_{\bar{i},\bar{j}})$. Let us describe this image.

Let us identify $H_{G_\alpha}^*(\mathbf{Z}_{\bar{i},\bar{j}})$ with $1_{\bar{i}} R(\alpha) 1_{\bar{j}}$. By Corollary 6.15.(b), the map $p_{i,j} \circ q_{i,j}$ becomes

$$(30) \quad 1_{\bar{i}} R(\alpha) 1_{\bar{j}} \rightarrow 1_{\bar{i}} R(\alpha) 1_{\bar{j}}, \quad x \mapsto 1_i x 1_j.$$

This shows that under the identification above $H_{G_\alpha}^*(\mathbf{Z}_{i,j})$ coincides with $1_i R(\alpha) 1_j$ as vector subspaces in $1_{\bar{i}} R(\alpha) 1_{\bar{j}}$. Summing over $i, j \in I^{(\alpha)}$ yields an isomorphism of vector spaces $H_{G_\alpha}^*(\mathbf{Z}_\alpha) \simeq \widehat{R}(\alpha)$.

Using Corollary 6.15.(a), we see that for any $\mathbf{h}, \mathbf{i}, \mathbf{j} \in I^{(\alpha)}$ and $x \in H_{G_\alpha}^*(\mathbf{Z}_{\mathbf{h},\mathbf{i}})$, $y \in H_{G_\alpha}^*(\mathbf{Z}_{\mathbf{i},\mathbf{j}})$ we have $p_{\mathbf{h},\mathbf{i}}(x) \cdot p_{\mathbf{i},\mathbf{j}}(y) = p_{\mathbf{h},\mathbf{j}}(x \cdot y)$. Therefore $H_{G_\alpha}^*(\mathbf{Z}_\alpha) \simeq \widehat{R}(\alpha)$ is an isomorphism of algebras, which proves (a) and (b).

Let us verify (c). Suppose $x \in H_{G_\alpha}^*(\mathbf{Z}_{i,j})$ acts on $H_{G_\alpha}^*(\tilde{\mathbf{F}}_\alpha) \simeq \text{Pol}_\alpha$ by

$$\text{Pol}_m^{\mathfrak{S}_j} 1_j \rightarrow \text{Pol}_m^{\mathfrak{S}_i} 1_i, \quad P 1_j \mapsto L(P) 1_i,$$

where $L : \text{Pol}_m^{\mathfrak{S}_j} \rightarrow \text{Pol}_m^{\mathfrak{S}_i}$ is a linear map. Then by Lemma 6.14, the element $p_{i,j}(x)$ acts on Pol_α by

$$\text{Pol}_m 1_j \rightarrow \text{Pol}_m 1_{\bar{i}}, \quad P 1_{\bar{i}} \mapsto L(\partial_{w_{0,j}}(y_j P)) 1_{\bar{i}}.$$

We see that this action agrees with the action of $\widehat{R}(\alpha)$ on Pol_α . \square

Proof of Lemma 6.10. This statement follows from [SW14, Theorem 3.11]. More precisely, Proposition 6.16 allows us to identify the algebra $\widehat{R}(n\delta)$ with a (non-unitary) subalgebra of the quiver Schur algebra. Now, [SW14, Theorem 3.11] yields a basis of $1_j R(n\delta) 1_i \subset \widehat{R}(n\delta)$. This basis coincides with each of the bases announced in the statement of Lemma 6.10, up to a change of basis by a triangular matrix. One verifies this by checking how elements of each basis act on the faithful polynomial representation. \square

7. SEMI-CUSPIDAL CATEGORY OF THE KRONECKER QUIVER

In this section, we establish a link between KLR algebras for the Kronecker quiver and Schur algebras for \mathbb{P}^1 . We will assume that either \mathbb{k} is a field or $\mathbb{k} = \mathbb{Z}$, unless otherwise stated.

7.1. Kronecker quiver. From now on, let $\Gamma = (1 \rightrightarrows 0)$ be the Kronecker quiver, and denote by δ the dimension vector $\alpha_0 + \alpha_1$.

Take $\alpha = n_0 \alpha_0 + n_1 \alpha_1$, and $m = |\alpha| = n_0 + n_1$. Let us introduce a more convenient notation for polynomial variables in the KLR algebra $R(\alpha)$. Let $\mathbf{i} \in I^\alpha$; it can be thought of as a sequence consisting of n_0 zeroes and n_1 ones. For each $1 \leq r \leq m$, let k_r be the number of $r' \in [1, r]$ such that $i_{r'} = i_r$. Inside $1_i R(\alpha) 1_i$, we then write $y_r = u_{k_r}$ if $i_r = 0$, and $y_r = v_{k_r}$ if $i_r = 1$.

Example 7.1. Let $\alpha = 2\alpha_0 + 3\alpha_1$, $\mathbf{i} = (0, 1, 1, 0, 1)$. Then we have

$$\begin{aligned} u_1 1_i &= y_1 1_i, & u_2 1_i &= y_4 1_i, \\ v_1 1_i &= y_2 1_i, & v_2 1_i &= y_3 1_i, & v_3 1_i &= y_5 1_i. \end{aligned}$$

In particular, for any non-negative integer n denote

$$\text{Poll}_n = \mathbb{k}[u_1, \dots, u_n, v_1, \dots, v_n].$$

Using the new notation, we can write $\text{Pol}_{n\delta} = \bigoplus_{\mathbf{i} \in I^{n\delta}} \text{Poll}_n 1_i$.

For each composition $\lambda = (\lambda_1, \dots, \lambda_k) \in \text{Comp}(n)$, consider the elements

$$\mathbf{i}_\lambda = (0^{(\lambda_1)}, 1^{(\lambda_1)}, \dots, 0^{(\lambda_k)}, 1^{(\lambda_k)}) \in I^{n\delta}, \quad \mathbf{j}_\lambda = \bar{\mathbf{i}}_\lambda = (0^{\lambda_1} 1^{\lambda_1} \dots 0^{\lambda_k} 1^{\lambda_k}) \in I^{n\delta}.$$

Let $\mathbf{i}_0 = \mathbf{j}_0 = \mathbf{j}_1^n = (0101 \dots 01) \in I^{n\delta}$. In order to unburden the notation, we will write $e_\lambda = 1_{\mathbf{i}_\lambda}$, $e_0 = 1_{\mathbf{i}_0}$, and $e = \sum_{\lambda \in \text{Comp}(n)} e_\lambda$. By Lemma 6.4 the algebra $R(n\delta)$ acts faithfully on $\text{Pol}_{n\delta}$. This implies that we have a faithful representation of $eR(n\delta)e$ on $e\text{Pol}_{n\delta}$. Since $e_\lambda \text{Pol}_{n\delta} \simeq \text{Poll}_n^{(\mathbb{S}_\lambda)^2}$, we obtain that $eR(n\delta)e$ has a faithful representation on $\bigoplus_{\lambda \in \text{Comp}(n)} \text{Poll}_n^{(\mathbb{S}_\lambda)^2}$.

7.2. Semi-cuspidal modules.

Definition 7.2. We say that a sequence $\mathbf{i} = (i_1, i_2, \dots, i_{2n}) \in I^{n\delta}$ is *non-cuspidal* if there exists an index $r \in [1, 2n]$ such that (i_1, i_2, \dots, i_r) contains more 1's than 0's. Denote by $I_{\text{nc}}^{n\delta}$ the set of all non-cuspidal sequences in $I^{n\delta}$, and write $1_{\text{nc}} = \sum_{\mathbf{i} \in I_{\text{nc}}^{n\delta}} 1_i$.

Given a \mathbb{k} -algebra A , let $\text{mod}(A)$ denote the category of finitely generated A -modules.

Definition 7.3 ([KM17b, §2.6]). We say that an $R(n\delta)$ -module M is *semi-cuspidal* if $1_i M = 0$ for each $\mathbf{i} \in I_{\text{nc}}^{n\delta}$. In other words, M is semi-cuspidal if it is annihilated by 1_{nc} .

Denote by $\text{cusp}(R(n\delta)) \subset \text{mod}(R(n\delta))$ the full subcategory of semi-cuspidal $R(n\delta)$ -modules. We clearly have $\text{cusp}(R(n\delta)) = \text{mod}(C(n\delta))$, where $C(n\delta)$ is the quotient algebra $R(n\delta)/R(n\delta)1_{\text{nc}}R(n\delta)$.

Lemma 7.4. *Let \mathbb{k} be a field. The $C(n\delta)$ -module $C(n\delta)e$ is a projective generator in the category $\text{mod}(C(n\delta))$. If \mathbb{k} has characteristic zero, then $C(n\delta)e_0$ is a projective generator of $\text{mod}(C(n\delta))$ as well.*

Proof. The second claim follows from [KM17b, Lemma 6.22].

Let us prove the first claim. It is equivalent to the fact that for each simple module $L \in \text{mod}(C(n\delta))$ we can find $v \in \text{Comp}(n)$ and a surjection $C(n\delta)e_v \rightarrow L$. In other words, we need to show that for each simple module L over $C(n\delta)$ we can find $v \in \text{Comp}(n)$ such that $e_v L \neq 0$. However, this follows from [KM17a, Theorem 5.5.4].

Let us provide some additional explanation about the given reference. The algebra \mathcal{S}_n is defined in [KM17a, §4.3] as a quotient of $R(n\delta)$ by the annihilator of some semi-cuspidal $R(n\delta)$ -module. In particular, we get a chain of surjections $R(n\delta) \rightarrow C(n\delta) \rightarrow \mathcal{S}_n$, and inclusions of categories $\text{mod}(\mathcal{S}_n) \subset \text{mod}(C(n\delta)) \subset \text{mod}(R(n\delta))$. For each $\nu \in \text{Comp}(n)$, [KM17a, §5.3] constructs an \mathcal{S}_n -module Z^ν and [KM17a, Theorem 5.5.4 (iii)] shows that $Z = \bigoplus_{\nu \in \text{Comp}(n)} Z^\nu$ is a projective generator in $\text{mod}(\mathcal{S}_n)$. On the other hand, the proof of [KM17a, Theorem 5.5.4] shows that there is a surjection of $R(n\delta)$ -modules from $R(n\delta)e_\nu$ (denoted by $I_\nu^n \Gamma_\nu$ in [KM17a]) to Z^ν . This proves that for each simple module $L \in \text{mod}(\mathcal{S}_n)$ there exists $\nu \in \text{Comp}(n)$ such that the $R(n\delta)$ -module $R(n\delta)e_\nu$ surjects to L , in particular we have $1_\nu L \neq 0$.

In order to complete the proof, we have to show that each simple module $L \in \text{mod}(C(n\delta))$ factors through the quotient $C(n\delta) \rightarrow \mathcal{S}_n$. In other words, we have to show that the categories $\text{mod}(C(n\delta))$ and $\text{mod}(\mathcal{S}_n)$ have the same number of simple modules. By [KM17a, Theorem 6], the number of simple modules in $\text{mod}(\mathcal{S}_n)$ is equal to the number of partitions of n . On the other hand, by [KM17b, Theorem 2] the number of simple modules in $\text{mod}(C(n\delta))$ is the same. \square

Corollary 7.5. *For \mathbb{k} a field, the algebra $C(n\delta)$ is Morita equivalent to $eC(n\delta)e$. Moreover, if \mathbb{k} has characteristic zero, $C(n\delta)$ is Morita equivalent to $e_0C(n\delta)e_0$.*

7.3. Thick calculus in $eR(n\delta)e$. In this section we construct some special element in the algebra $eR(n\delta)e$.

Let us introduce some diagrammatic abbreviations. First, we write

$$\left| \begin{array}{c} a \\ \vdots \\ \vdots \\ \vdots \end{array} \right. = \left[\begin{array}{c} 0 \ 0 \ \dots \ 0 \\ \vdots \\ \vdots \\ \vdots \\ \vdots \\ \vdots \\ \vdots \\ \vdots \end{array} \right] \left[\begin{array}{c} 1 \ 1 \ \dots \ 1 \\ \vdots \\ \vdots \\ \vdots \\ \vdots \\ \vdots \\ \vdots \\ \vdots \end{array} \right].$$

In particular, for $\lambda = (\lambda_1, \dots, \lambda_k) \in \text{Comp}(n)$, we draw the idempotent e_λ as k parallel vertical lines with labels $\lambda_1, \dots, \lambda_k$. Moreover, a strand with label a is allowed to carry a polynomial $P \in \text{Poll}_a^{(\mathfrak{S}_a)^2}$. In fact, it would make sense to allow polynomials from Poll_a ; however, the presence of an idempotent allows us to replace any polynomial by a symmetric one.

Next, we write

$$\begin{array}{c} a \quad b \\ \diagdown \quad \diagup \\ a+b \end{array} := \left[\begin{array}{c} 0^{(a)} \quad 1^{(a)} \quad 0^{(b)} \quad 1^{(b)} \\ \vdots \\ \vdots \\ \vdots \\ \vdots \\ \vdots \\ \vdots \\ \vdots \\ 0^{(a+b)} \quad 1^{(a+b)} \end{array} \right], \quad \begin{array}{c} a+b \\ \diagdown \quad \diagup \\ a \quad b \end{array} := \left[\begin{array}{c} 0^{(a+b)} \quad 1^{(a+b)} \\ \vdots \\ \vdots \\ \vdots \\ \vdots \\ \vdots \\ \vdots \\ \vdots \\ 0^{(a)} \quad 1^{(a)} \quad 0^{(b)} \quad 1^{(b)} \end{array} \right].$$

Assume that $\lambda, \mu \in \text{Comp}(n)$ are such that μ is a split of λ at k -th place. Then, similarly to Section 3.4, we define elements $S_\lambda^\mu \in e_\mu R(n\delta)e_\lambda$ and $M_\mu^\lambda \in e_\lambda R(n\delta)e_\mu$ by (16), but using the diagrammatic calculus defined above for $eR(n\delta)e$ instead of the analogous calculus for the curve Schur algebra. It is easy to check that the elementary splits and merges above are associative as in (3.4). This allows us to extend the definitions of S_λ^μ and M_μ^λ to any λ, μ with $\mathfrak{S}_\mu \subset \mathfrak{S}_\lambda$.

Remark 7.6. It is not the case that we can write any element of $eR(n\delta)e$ as a linear combination of diagrams containing splits, merges and symmetric polynomials. However, we will see in Remark 7.14 that this holds for $eC(n\delta)e$. Moreover, it can be shown that $eR(n\delta)e$ is an idempotent truncation of the quiver Schur algebra and the diagrams introduced above are nothing else than the diagrams in the quiver Schur algebra (replacing the label a by $a\delta$). However, here we allow only labels of the form $a\delta$, while quiver Schur algebras allow more general labels of the form $a_0\alpha_0 + a_1\alpha_1$. This is the reason why our thick calculus does not have enough diagrams to represent every element in $eR(n\delta)e$.

Let $\lambda, \mu \in \text{Comp}(n)$ be such that $\mathfrak{S}_\mu \subset \mathfrak{S}_\lambda$. Let us give a geometric description of the operators S_λ^μ , M_μ^λ . We have an obvious projection $\tilde{\mathbf{F}}_{i_\mu} \rightarrow \tilde{\mathbf{F}}_{i_\lambda}$, obtained by forgetting some components of the flag.

This allows us to define the following correspondences:

$$\mathbf{Z}_{i_\mu, i_\lambda}^S := \widetilde{\mathbf{F}}_{i_\mu} \times_{\widetilde{\mathbf{F}}_{i_\lambda}} \widetilde{\mathbf{F}}_{i_\lambda} \subset \widetilde{\mathbf{F}}_{i_\mu} \times_{E_\alpha} \widetilde{\mathbf{F}}_{i_\lambda} = \mathbf{Z}_{i_\mu, i_\lambda}, \quad \mathbf{Z}_{i_\lambda, i_\mu}^M := \widetilde{\mathbf{F}}_{i_\lambda} \times_{\widetilde{\mathbf{F}}_{i_\mu}} \widetilde{\mathbf{F}}_{i_\mu} \subset \widetilde{\mathbf{F}}_{i_\lambda} \times_{E_\alpha} \widetilde{\mathbf{F}}_{i_\mu} = \mathbf{Z}_{i_\lambda, i_\mu}.$$

Lemma 7.7. *Under the identification in Proposition 6.16, we have $S_\lambda^\mu = [\mathbf{Z}_{i_\mu, i_\lambda}^S]$ and $M_\mu^\lambda = [\mathbf{Z}_{i_\lambda, i_\mu}^M]$.*

Proof. It suffices to check these equalities on the faithful representation $\text{Pol}_{(n\delta)}$ of $\widehat{R}(n\delta)$. The actions of S_λ^μ and M_μ^λ can be easily obtained from Lemma 6.4. On the other hand, the actions of $[\mathbf{Z}_{i_\mu, i_\lambda}^S]$ and $[\mathbf{Z}_{i_\lambda, i_\mu}^M]$ were computed in larger generality (for quiver Schur algebras) in [Prz19, Theorem 4.7]; see also [SW14, Proposition 3.4].

By [Prz19, Theorem 4.7(b)], the element $[\mathbf{Z}_{i_\lambda, i_\mu}^M]$ acts by

$$\text{Pol}_{2n}^{\mathfrak{S}_{i_\mu}} 1_{i_\mu} \rightarrow \text{Pol}_{2n}^{\mathfrak{S}_{i_\lambda}} 1_{i_\lambda}, \quad P1_{i_\mu} \mapsto P1_{i_\lambda},$$

which coincides with the action of M_μ^λ .

For S_λ^μ , assume $\lambda = (a+b)$ and $\mu = (a, b)$; the general case is proved in the same way, but requires more complicated notation. By [Prz19, Theorem 4.7(a)], the element $[\mathbf{Z}_{i_\mu, i_\lambda}^S]$ acts on $\text{Pol}_{(n\delta)}$ by

$$\text{Pol}_{2n}^{\mathfrak{S}_{i_\lambda}} 1_{i_\lambda} \rightarrow \text{Pol}_{2n}^{\mathfrak{S}_{i_\mu}} 1_{i_\mu}, \quad P1_{i_\mu} \mapsto \sum_{w_u, w_v \in \mathfrak{S}_n / (\mathfrak{S}_a \times \mathfrak{S}_b)} w_u w_v \left(P \prod_{i=1}^a \prod_{j=a+1}^{a+b} \frac{(v_i - u_j)^2}{(u_i - u_j)(v_i - v_j)} \right),$$

where w_u permutes u_i 's, and w_v permutes v_i 's. Let $\partial_{w_{0,a,b}}^u$ be the composition of Demazure operators as in Corollary 4.6 acting on variables u_1, \dots, u_n , and define $\partial_{w_{0,a,b}}^v$ analogously. Applying Lemma 4.5, we have

$$\sum_{w_u, w_v \in \mathfrak{S}_n / (\mathfrak{S}_a \times \mathfrak{S}_b)} w_u w_v \left(P \prod_{i=1}^a \prod_{j=a+1}^{a+b} \frac{(v_i - u_j)^2}{(u_i - u_j)(v_i - v_j)} \right) = \partial_{w_{0,a,b}}^u \partial_{w_{0,a,b}}^v \left(P \prod_{i=1}^a \prod_{j=a+1}^b (v_i - u_j)^2 \right),$$

and the right-hand side coincides with the action of S_λ^μ given by Lemma 6.4. \square

As in Section 3.4, we will use the following abbreviation:

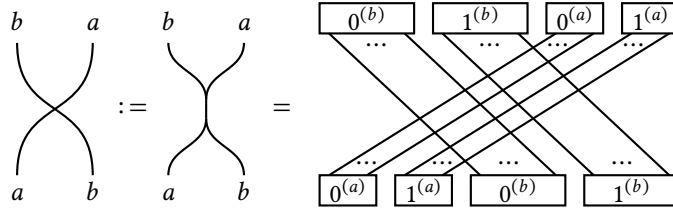

Let $\lambda, \mu \in \text{Comp}(n)$ be such that μ is obtained by permuting components in $\lambda = (\lambda_1, \dots, \lambda_r)$, and $w \in \mathfrak{S}_r$ the corresponding permutation. We can define the permutation element $R_\lambda^\mu(w) \in e_\lambda R(n\delta) e_\mu$ as in Section 3.4; recall that it depends not only on w , but also on the choice of a reduced decomposition of w .

7.4. Basis of $eR(n\delta)e$. Let $\lambda, \mu \in \text{Comp}(n)$. To each element $w \in {}^{i_\mu} \mathfrak{S}^{i_\lambda}$, we can associate a pair $(x, y) \in {}^\mu \mathfrak{S}^\lambda \times {}^\mu \mathfrak{S}^\lambda$, where x is the restriction of w to positions colored by 0, and y to positions colored by 1. This induces a bijection ${}^{i_\mu} \mathfrak{S}^{i_\lambda} \xrightarrow{\sim} {}^\mu \mathfrak{S}^\lambda \times {}^\mu \mathfrak{S}^\lambda$. We will use this bijection implicitly from now on, and write $\psi_{(x,y)}$ instead of ψ_w . In the case $x = y$, we may also write $\psi_{(x)}$ instead of $\psi_{(x,x)}$ by abuse of notation.

As in Section 6.4, consider the elements $i'_\lambda, i'_\mu \in I^{(n\delta)}$ (both depending on λ, μ, w) characterized by

$$\overline{i'_\lambda} = \overline{i_\lambda}, \quad \overline{i'_\mu} = \overline{i_\mu}, \quad \mathfrak{S}_{i'_\lambda} = w^{-1} \mathfrak{S}_{i'_\mu} w = \mathfrak{S}_{i_\lambda} \cap w^{-1} \mathfrak{S}_{i_\mu} w.$$

The elements $i_\lambda, i_\mu, i'_\lambda$ and i'_μ here play the roles of i, j, i' and j' respectively in Section 6.4. Note that in general i'_λ cannot be expressed as $i_{\lambda'}$ for $\lambda' \in \text{Comp}(n)$; however, this works if $x = y$.

The following is a restatement of the second part of Lemma 6.10 for the Kronecker quiver.

Lemma 7.8. *For each $\lambda, \mu \in \text{Comp}(n)$, the following set is a basis of the \mathbb{k} -module $e_\mu R(n\delta) e_\lambda$:*

$$\left\{ \psi_{w_{0,i_\mu, i'_\mu}} \psi_{(x,y)} P e_\lambda : x, y \in {}^\mu \mathfrak{S}^\lambda, P \in B_{i'_\lambda} \right\}.$$

Remark 7.9. (a) The lemma above implies that for any $\lambda \in \text{Comp}(n)$ we have an isomorphism of \mathbb{k} -modules $\text{Poll}_n^{(\mathfrak{S}_\lambda)^2} \xrightarrow{\sim} e_\lambda R(n\delta)e_{(n)}$, $P \mapsto P \cdot S_{(n)}^\lambda$;
 (b) suppose that we have $\lambda_r = 1$ for some index r , and set $k = \lambda_1 + \dots + \lambda_{r-1} + 1$. The quadratic relation $\psi_{2k-1}^2 e_\lambda = (u_k - v_k)^2 1_{j_\lambda}$ and the fact that the idempotent $s_{2k-1}(j_\lambda)$ is non-cuspidal implies that the polynomial $(u_k - v_k)^2$ is in the kernel of the map $\text{Poll}_n^{(\mathfrak{S}_\lambda)^2} \rightarrow e_\lambda C(n\delta)e_{(n)}$, $P \mapsto P \cdot S_{(n)}^\lambda$.

Example 7.10. Let $n = 4$, $\lambda = (3, 1)$, $\mu = (1, 3)$, $w = (1, 3, 4, 6, 7, 8, 5, 2)$. In this case $x = (1, 2, 3, 4)$, $y = (2, 3, 4, 1)$, and the set B_{j_λ} is a basis of the vector space of polynomials in $\mathbb{k}[u_1, u_2, u_3, u_4, v_1, v_2, v_3, v_4]^{\mathfrak{S}_2 \times \mathfrak{S}_2}$, where $\mathfrak{S}_2 \times \mathfrak{S}_2$ acts by transpositions $u_1 \leftrightarrow u_2$ and $v_1 \leftrightarrow v_2$. For example, take $P = u_1 u_2 v_4$. Then the basis element $\psi_{w_{0, i_\mu, i'_\mu}} \psi_w P e_\lambda$ is given by the following diagram:

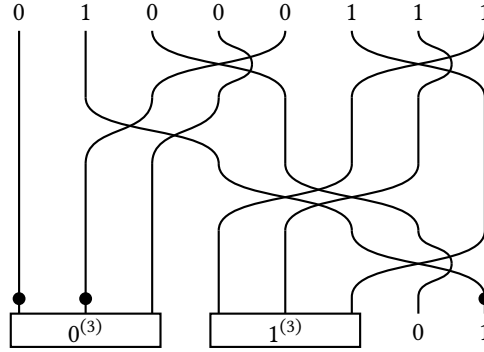

Lemma 7.11. Let w be such that $x \neq y$. Then the reduced decomposition of w can be chosen in such a way that every basis element $\psi_{w_{0, i_\mu, i'_\mu}} \psi_w P e_\lambda$ goes to zero under the quotient map $eR(n\delta)e \rightarrow eC(n\delta)e$.

Proof. For a composition $\mu = (\mu_1, \dots, \mu_k)$ and $r \in [1, n]$, let $L(r) \in [1, k]$ be the unique index for which $\mu_1 + \dots + \mu_{L(r)-1} < r \leq \mu_1 + \dots + \mu_{L(r)}$. If $x \neq y$, then we can find an index $r \in [1, n]$ such that $L(x(r)) > L(y(r))$. Indeed, assume the contrary, that is that for every $r \in [1, n]$ we have $L(x(r)) \leq L(y(r))$. Since $\sum_{1 \leq r \leq n} L(x(r)) = \sum_{1 \leq r \leq n} L(y(r))$, this implies $L(x(r)) = L(y(r))$ for every r . On the other hand, since x is the shortest element in $\mathfrak{S}_\mu x$, the values of $L(x(r))$ for each r determine x uniquely, so we must have $x = y$.

Let r be as above. Further, let a be the position of the r -th appearance of “0” in j_λ (counting from the left), and b is the position of the r -th appearance of “1” in j_λ . We have $1 \leq a < b \leq 2n$ and $w(a) > w(b)$. Let $c \in [a, b - 1]$ be the unique index such that $(j_\lambda)_c = 0$ and $(j_\lambda)_{c+1} = 1$. We have

$$w(c) \geq w(c-1) \geq \dots \geq w(a+1) \geq w(a) > w(b) \geq w(b-1) \geq \dots \geq w(c+1).$$

Then we can pick such a reduced decomposition of w that on the bottom of the diagram for $\psi_w 1_{j_\lambda}$ we cross all strands at positions $[a, c]$ with all strands at positions $[c+1, b]$. This implies that $\psi_w 1_{j_\lambda}$ is zero in $C(n\delta)$ because it factors through a non-cuspidal idempotent, and thus $\psi_{w_{0, i_\mu, i'_\mu}} \psi_w P e_\lambda$ is zero in $eC(n\delta)e$. \square

The following example illustrates the proof.

Example 7.12. Let $\lambda = (3, 1)$, $\mu = (2, 2)$, and $w = (1, 5, 6, 3, 4, 7, 2, 8)$. Then we have $x = (1, 3, 4, 2)$ and $y = (1, 2, 3, 4)$. In this case we can take $r = 2$, because $L(x(2)) = 2$ and $L(y(2)) = 1$. Then $a = 2$, $b = 5$, $c = 3$, and we should fix a reduced decomposition of w such that on the bottom of the diagram of $\psi_w 1_{j_\lambda}$ the second and the third strands cross the fourth and the fifth. The bottom of this diagram will look as follows:

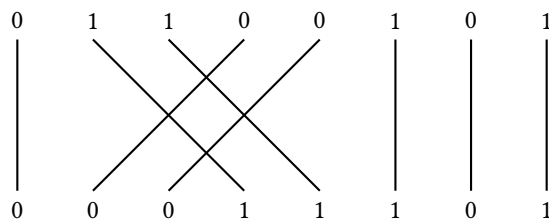

On the top of this diagram we have a non-cuspidal sequence 01100101. Therefore the element $\psi_w 1_{j_\lambda}$ is zero in $C(n\delta)$, because it factors through a non-cuspidal idempotent.

From now on, we will always assume that the reduced decompositions are chosen as in Lemma 7.11. The following statement is an immediate corollary of Lemmas 7.8 and 7.11.

Corollary 7.13. *The algebra $eC(n\delta)e$ is spanned by the set $\left\{ \psi_{w_{0,i_\mu,i'_\mu}} \psi_{(x)} P e_\lambda : x \in \mathfrak{S}_\mu \setminus \mathfrak{S}_n / \mathfrak{S}_\lambda, P \in B_{i'_\lambda} \right\}$.*

Remark 7.14. Consider a basis element $\psi_{w_{0,i_\mu,i'_\mu}} \psi_{(x)} P e_\lambda$ as above. Let $\lambda', \mu' \in \text{Comp}(n)$ be such that $\mathfrak{S}_{\lambda'} = \mathfrak{S}_\lambda \cap x^{-1} \mathfrak{S}_\mu x$ and $\mathfrak{S}_{\mu'} = \mathfrak{S}_\mu \cap x \mathfrak{S}_\lambda x^{-1}$. Then, for an appropriate choice of a reduced decomposition of x , the element $\psi_{(x)}$ can be written as $\psi_{(x)} = \psi_1 \psi_2 \psi_3$, where $\psi_3 = S_\lambda^{\lambda'}$, $\psi_2 = R_{\lambda'}^{\mu'}$ and $\psi_{w_{0,i_\mu,i'_\mu}} \psi_1 = M_{\mu'}^\mu$. In particular, we see that each element of the algebra $eC(n\delta)e$ is a linear combination of diagrams containing splits, merges and polynomials.

7.5. Comparison with sheaves on \mathbb{P}^1 . In this section we will establish a relation between $eC(n\delta)e$ and the Schur algebra of the projective line $\mathcal{S}_n = \mathcal{S}_n^{\mathbb{P}^1}$.

We say that a representation $M \in E_{n\delta}$ is *regular* if there exists an invertible linear combination of two arrows in Γ .⁵ Regular representations form an open subvariety $E_{n\delta}^{\text{reg}} \subset E_{n\delta}$. Similarly, we define $\widetilde{\mathbf{F}}_{n\delta}^{\text{reg}} \subset \widetilde{\mathbf{F}}_{n\delta}$, $\mathbf{Z}_{n\delta}^{\text{reg}} \subset \mathbf{Z}_{n\delta}$ as inverse images of $E_{n\delta}^{\text{reg}}$ under the natural maps $\widetilde{\mathbf{F}}_{n\delta} \rightarrow E_{n\delta}$ and $\mathbf{Z}_{n\delta} \rightarrow E_{n\delta}$ respectively. We also set $\widetilde{\mathbf{F}}_i^{\text{reg}} = \widetilde{\mathbf{F}}_i \cap \widetilde{\mathbf{F}}_{n\delta}^{\text{reg}}$, $\mathbf{Z}_{i,j}^{\text{reg}} = \mathbf{Z}_{i,j} \cap \mathbf{Z}_{n\delta}^{\text{reg}}$. Let us make the following standard observation:

Lemma 7.15. *If a sequence $i \in I^{n\delta}$ is non-cuspidal, then $\widetilde{\mathbf{F}}_i^{\text{reg}} = \emptyset$.*

Proof. Each sub-representation of a regular representation has dimension vector of the form $m_0 \alpha_0 + m_1 \alpha_1$ such that $m_0 \geq m_1$. In particular, a regular representation cannot stabilize a flag of non-cuspidal type. \square

Corollary 7.16. *If $i \in I^{n\delta}$ is non-cuspidal, then the idempotent 1_i lies in the kernel of the pullback map*

$$R(n\delta) \simeq H_{G_{n\delta}}^*(\mathbf{Z}_{n\delta}) \rightarrow H_{G_{n\delta}}^*(\mathbf{Z}_{n\delta}^{\text{reg}}).$$

In particular, the pullback yields a map $C(n\delta) \rightarrow H_^{G_{n\delta}}(\mathbf{Z}_{n\delta}^{\text{reg}})$.*

Remark 7.17. It will be more important for us to have a truncated version by the idempotents e_λ . Let us write $\mathbf{Z}_{n\delta,e} = \bigsqcup_{\lambda,\mu \in \text{Comp}(n)} \mathbf{Z}_{i_\lambda,i_\mu}$. Then the pullback map $eR(n\delta)e \simeq H_{G_{n\delta}}^*(\mathbf{Z}_{n\delta,e}) \rightarrow H_{G_{n\delta}}^*(\mathbf{Z}_{n\delta,e}^{\text{reg}})$ factors through $eC(n\delta)e \rightarrow H_{G_{n\delta}}^*(\mathbf{Z}_{n\delta,e}^{\text{reg}})$.

Recall [Bei78] that we have an equivalence of bounded derived categories

$$(31) \quad R\text{Hom}(\mathcal{O}(-1) \oplus \mathcal{O}, -) : D^b(\text{Coh } \mathbb{P}^1) \rightarrow D^b(\text{Rep } \Gamma).$$

Restricting this map to torsion sheaves of length n and representations with dimension vector $n\delta$ respectively, we obtain an open embedding of algebraic stacks

$$\varepsilon : \mathcal{T}_n \hookrightarrow \text{Rep}_{n\delta} \Gamma = [E_{n\delta}/G_{n\delta}], \quad \mathcal{F} \mapsto \left(\Gamma(\mathcal{F}) \xrightarrow{\Gamma(\mathcal{O}(1))} \Gamma(\mathcal{F}(1)) \right).$$

Moreover, the image of ε is precisely the substack of regular representations. Let $\varphi_n : H^*(\text{Rep}_{n\delta} \Gamma, \mathbb{k}) \rightarrow H^*(\mathcal{T}_n, \mathbb{k})$ be the corresponding pullback map.

Lemma 7.18. *The ring homomorphism $\varphi_n : \text{Poll}_n^{\mathfrak{S}_n \times \mathfrak{S}_n} \rightarrow \mathbf{P}_n^{\mathfrak{S}_n}$ is obtained as a restriction of the following map to invariants:*

$$(32) \quad \text{Poll}_n \rightarrow \mathbf{P}_n; \quad u_i \mapsto x_i, \quad v_i \mapsto x_i + c_i.$$

⁵One can check that this definition agrees with the standard definition of regular modules [ASS06, Definition VIII.2.12]; see also Appendix A.

Proof. By universal coefficients, it suffices to prove the statement for $\mathbb{k} = \mathbb{Z}$. We have the following commutative diagram:

$$\begin{array}{ccc} \mathcal{T}_1^n & \xrightarrow{\oplus} & \mathcal{T}_n \\ \downarrow & & \downarrow \\ (\text{Rep}_\delta \Gamma)^n & \xrightarrow{\oplus} & \text{Rep}_{n\delta} \Gamma \end{array}$$

Since pullback is functorial, and the pullback along the lower horizontal map realizes the inclusion $\text{Poll}_n^{\mathbb{S}_n \times \mathbb{S}_n} \subset \text{Poll}_n$, it suffices to prove our claim for $n = 1$. We will use the notations from Example 5.5.

The variables u, v are the first Chern classes of tautological line bundles on $\text{Rep}_{(1,1)} \Gamma$, which associate to a representation $U \rightrightarrows V$ vector spaces U and V respectively. We denote by π the projection map $\mathcal{T}_1 \times \mathbb{P}^1 \rightarrow \mathcal{T}_1$. By definition of the embedding ε , the restriction of these line bundles to \mathcal{T}_1 is $\Gamma(\mathcal{E})$ and $\Gamma(\mathcal{E}(1))$ respectively, where $\Gamma(-) = R^0 \pi_*(-)$ denotes the sheaf of global sections along \mathbb{P}^1 . Let us compute the Chern character of $\Gamma(\mathcal{E}(k))$, $k \in \mathbb{Z}$, by applying Grothendieck-Riemann-Roch theorem.

$$\begin{aligned} \text{ch}(\Gamma(\mathcal{E}(k))) &= \pi_* (\text{ch}(\mathcal{E}) \text{ch}(\mathcal{O}(k)) \text{td}(\mathbb{P}^1)) = \pi_* (\exp(x)(1 - \exp(-c - p)) \exp(kp)(1 + p)) \\ &= \pi_* (\exp(x)(c + p + kcp)) = \exp(x + kc). \end{aligned}$$

In particular $\text{ch}(\Gamma(\mathcal{E})) = \exp(x)$ and $\text{ch}(\Gamma(\mathcal{E}(1))) = \exp(x + c)$, so that $\varphi_1(u) = x$ and $\varphi_1(v) = x + c$. \square

Let $\lambda \in \text{Comp}(n)$.

Lemma 7.19. *We have a natural isomorphism $\mathcal{F}_\lambda \simeq \mathcal{T}_n \times_{\text{Rep}_{n\delta}} [\tilde{\mathbf{F}}_{i_\lambda} / G_{n\delta}]$.*

Proof. Let $M \in \text{Rep}_{n\delta} \Gamma$, and $M' \subset M$ a subrepresentation with dimension vector $n'\delta$, $n' < n$. Since the vertex 0 in Γ has only incoming arrows, M' uniquely determines a compatible flag $M'_0 \subset M' \subset M$, with $\dim M'_0 = n'\alpha_0$. Therefore the derived equivalence (31) provides us with an injective map

$$\begin{aligned} \mathcal{F}_\lambda &\rightarrow [\tilde{\mathbf{F}}_{i_\lambda}^{\text{reg}} / G_{n\delta}] = \mathcal{T}_n \times_{\text{Rep}_{n\delta}} [\tilde{\mathbf{F}}_{i_\lambda} / G_{n\delta}], \\ (\mathcal{E}_1 \subset \dots \subset \mathcal{E}_k) &\mapsto (0 \rightrightarrows \Gamma(\mathcal{E}_1(1))) \subset \varepsilon(\mathcal{E}_1) \subset \dots \subset (\Gamma(\mathcal{E}_{k-1}) \rightrightarrows \Gamma(\mathcal{E}_k(1))) \subset \varepsilon(\mathcal{E}_k). \end{aligned}$$

Further, let M be regular, and M' as above. Since the restriction of an isomorphism is an isomorphism, then M' is also regular. Therefore every flag in $\tilde{\mathbf{F}}_{i_\lambda}^{\text{reg}}$ comes from a flag in \mathcal{F}_λ , and the map above is an isomorphism. \square

As before, let us define $\varphi_\lambda : \text{Poll}_n^{\mathbb{S}_\lambda \times \mathbb{S}_\lambda} \rightarrow \mathbf{P}_n^{\mathbb{S}_\lambda}$ as pullback along the open embedding $\mathcal{F}_\lambda \subset [\tilde{\mathbf{F}}_{i_\lambda} / G_{n\delta}]$. The following corollary is proved completely analogously to Lemma 7.18.

Corollary 7.20. *The map φ_λ is obtained as a restriction of (32) to the invariants.*

Lemma 7.21. *For \mathbb{k} a field of characteristic zero, the maps $\varphi_n, \varphi_\lambda$ are surjective.*

Proof. It is enough to prove the statement for φ_n . By a theorem of Weyl [Wey39, II.3], the ring $\mathbf{P}_n^{\mathbb{S}_n}$ is generated by elements $p_{k,0} = \sum_i x_i^k$, $p_{k,1} = \sum_i c_i x_i^k$. However, these elements can also be expressed as $p_{k,0} = \varphi_n(\sum_i u_i^k)$, $p_{k,1} = \frac{1}{k} \varphi_n(\sum_i v_i^k - \sum_i u_i^k)$. \square

Another immediate corollary from Lemma 7.19 is that we have $\mathcal{F}_\mu \times_{\mathcal{T}_n} \mathcal{F}_\lambda \simeq [Z_{i_\mu, i_\lambda}^{\text{reg}} / G_{n\delta}]$. The resulting restriction map $eR(n\delta)e \rightarrow \mathcal{S}_n$ is a homomorphism of algebras by smooth base change and functoriality of pullbacks. By Remark 7.17, it descends to a homomorphism of algebras

$$\Phi_n : eC(n\delta)e \rightarrow \mathcal{S}_n.$$

Remark 7.22. Note that both $eC(n\delta)e$ and \mathcal{S}_n are defined over any commutative ring \mathbb{k} , in particular over the finite field $\mathbb{k} = \mathbb{F}_p$. Since Φ_n is essentially a pullback along an open embedding, it is also defined for any \mathbb{k} . This will become important at the end of this section.

Proposition 7.23. *The algebra homomorphism Φ_n sends each thick diagram in $eC(n\delta)e$ to the same diagram in \mathcal{S}_n , replacing each polynomial $P \in \text{Poll}_a^{(\mathbb{S}_a)^2}$ on a strand of thickness a by $\varphi_a(P)$.*

Proof. Follows from Lemmas 7.7 and 7.18. \square

Restricting to polynomial operators, we have the following commutative square:

$$(33) \quad \begin{array}{ccc} \text{Poll}_n^{\mathfrak{S}_n^2} & \xrightarrow{\varphi_n} & \mathbf{P}_n^{\mathfrak{S}_n} \\ \downarrow \iota_n & & \downarrow \\ eC(n\delta)e & \xrightarrow{\Phi_n} & \mathfrak{S}_n \end{array}$$

Let J_n be the kernel of ι_n . It is clear that $J_n \subset \text{Ker } \varphi_n$; we will show in Lemma 7.32 that this is actually an equality. In order to prove this, we will need some preparations.

7.6. Shuffle products. Consider the product $*$: $\text{Poll}_n^{(\mathfrak{S}_n)^2} \times \text{Poll}_m^{(\mathfrak{S}_m)^2} \rightarrow \text{Poll}_{n+m}^{(\mathfrak{S}_{n+m})^2}$ given by

$$(34) \quad \begin{array}{c} n+m \\ | \\ \boxed{P * Q} \\ | \\ n+m \end{array} = \begin{array}{c} n+m \\ \swarrow \quad \searrow \\ \boxed{P} \quad \boxed{Q} \\ \swarrow \quad \searrow \\ n \quad m \\ \swarrow \quad \searrow \\ n+m \end{array} .$$

Thanks to the proof of Lemma 7.7, we have the following expression for shuffle product:

$$P * Q = \partial_{w_{0,a,b}}^u \partial_{w_{0,a,b}}^v \left((P \otimes Q) \prod_{i=1}^a \prod_{j=a+1}^b (v_i - u_j)^2 \right),$$

We also consider the shuffle product $*$: $\mathbf{P}_n^{\mathfrak{S}_n} \times \mathbf{P}_m^{\mathfrak{S}_m} \rightarrow \mathbf{P}_{n+m}^{\mathfrak{S}_{n+m}}$, given by the same picture (34), but using the diagrammatic calculus in \mathfrak{S}_n instead of the diagrammatic calculus in $eR(n\delta)e$.

Lemma 7.24. *The map*

$$\bigoplus_n \varphi_n : \bigoplus_n \text{Poll}_n^{(\mathfrak{S}_n)^2} \rightarrow \bigoplus_n \mathbf{P}_n^{\mathfrak{S}_n}$$

is a homomorphism of algebras (with respect to the operations $*$).

Proof. Follows from the definitions and Proposition 7.23. \square

For a polynomial $f \in \text{Poll}_n$, denote by $\text{ev}(f)$ the polynomial in $\mathbb{k}[v_1, \dots, v_n]$ obtained from f after evaluation $u_1 = u_2 = \dots = u_n = 0$. Set $D_n^u = \partial_1^u \partial_2^u \dots \partial_{n-1}^u$ and $D_n^v = \partial_1^v \partial_2^v \dots \partial_{n-1}^v$, where ∂_i^u denote Demazure operators in variables u_1, \dots, u_n , and ∂_i^v are defined analogously.

Remark 7.25. Note that $D_n^u(u_n^{n-1}) = (-1)^{n-1}$. This identity allows to simplify expressions of the form $\text{ev}(D_n^u(P))$, where $P \in \mathbb{k}[v_1, \dots, v_n]^{\mathfrak{S}_n}[u_n]$. Write $P = \sum_r u_n^r P_r$, where $P_r \in \mathbb{k}[v_1, \dots, v_n]^{\mathfrak{S}_n}$. Then we have

$$\text{ev}(D_n^u(P)) = (-1)^{n-1} (P_{n-1}).$$

Denote by $\sigma_k^{(n)}$ the k -th elementary symmetric polynomial on the variables v_1, \dots, v_n ; we use the convention $\sigma_0^{(n)} = 1$. We also denote the unit in Poll_n by 1_n .

Lemma 7.26. *Assume $1 \leq k \leq n$. We have $\text{ev}(1_{n-1} * (v - u)u^{k-1}) = (-1)^{k-1} \sigma_k^{(n)}$.*

Proof. Recall that

$$1_{n-1} * (v - u)u^{k-1} = D_n^u D_n^v \left[(v_1 - u_n)^2 (v_2 - u_n)^2 \dots (v_{n-1} - u_n)^2 (v_n - u_n) u_n^{k-1} \right].$$

For $k = 1$, we have

$$\begin{aligned} \text{ev}(1_{n-1} * (v - u)) &= \text{ev} \left(D_n^u D_n^v \left[(v_1 - u_n)^2 (v_2 - u_n)^2 \dots (v_{n-1} - u_n)^2 (v_n - u_n) \right] \right) \\ &= \text{ev} \left(D_n^u \left[(v_1 - u_n) (v_2 - u_n) \dots (v_n - u_n) \right] \right) \\ &= v_1 + v_2 + \dots + v_n = \sigma_1^{(n)}. \end{aligned}$$

Now, assume $k > 1$. We fix k and proceed by induction on n . If $n = k$, we have

$$\begin{aligned} \text{ev}(1_{n-1} * (v-u)u^{k-1}) &= \text{ev}\left(D_n^u D_n^v \left[(v_1 - u_n)^2 (v_2 - u_n)^2 \dots (v_{n-1} - u_n)^2 (v_n - u_n) u_n^{n-1} \right]\right) \\ &= (-1)^{n-1} (D_n^v (v_1^2 v_2^2 \dots v_{n-1}^2 v_n)) \\ &= (-1)^{n-1} (v_1 v_2 \dots v_{n-1} v_n) = (-1)^{n-1} \sigma_n^{(n)}. \end{aligned}$$

where the second equality follows from Remark 7.25.

Now assume $n > k > 1$. Let us write $Q(u, v) = (v_1 - u_n)^2 (v_2 - u_n)^2 \dots (v_{n-2} - u_n)^2$ for brevity. We have

$$\partial_{n-1}^v \left[Q(u, v) (v_{n-1} - u_n)^2 (v_n - u_n) u_n^{k-1} \right] = Q(u, v) (v_{n-1} - u_n) (v_n - u_n) u_n^{k-1}.$$

This implies

$$\begin{aligned} \text{ev}(1_{n-1} * (v-u)u^{k-1}) &= \text{ev}\left(D_n^u D_n^v \left[Q(u, v) (v_{n-1} - u_n)^2 (v_n - u_n) u_n^{k-1} \right]\right) \\ &= -\text{ev}\left(D_{n-1}^u D_{n-1}^v \left[Q(u, v) (v_{n-1} - u_{n-1}) (v_n - u_{n-1}) u_{n-1}^{k-2} \right]\right) \\ &= -v_n \text{ev}(1_{n-2} * (u-v)u^{k-2}) + \text{ev}(1_{n-2} * (v-u)u^{k-1}) \\ &= -v_n (-1)^{k-2} \sigma_{k-1}^{(n-1)} + (-1)^{k-1} \sigma_k^{(n-1)} = (-1)^{k-1} \sigma_k^{(n)}, \end{aligned}$$

where the second equality uses Remark 7.25. \square

For each positive integer k we set $\tilde{f}_k = (v-u)u^{k-1} \in \text{Poll}_1$, and $\tilde{t}_{n,k} = 1_{n-1} * \tilde{f}_k \in \text{Poll}_n^{(\mathbb{S}_n)^2}$. The following proposition follows from Lemma 7.26.

Proposition 7.27. *The commutative ring $\text{Poll}_n^{(\mathbb{S}_n)^2}$ is generated by $\mathbb{k}[u_1, \dots, u_n]^{\mathbb{S}_n}$ together with elements $\tilde{t}_{n,k}$ for $k \in [1, n]$.*

7.7. Spanning set of $\text{Poll}_n^{(\mathbb{S}_n)^2} / J_n$.

Lemma 7.28. *For each positive integer r , we have the following equality in $\text{Poll}_n^{(\mathbb{S}_n)^2} / J_n$:*

$$\tilde{t}_{n,k_1} \cdot \tilde{t}_{n,k_2} \cdot \dots \cdot \tilde{t}_{n,k_r} = \begin{cases} 1_{n-r} * \tilde{f}_{k_1} * \tilde{f}_{k_2} * \dots * \tilde{f}_{k_r}, & \text{if } r \leq n, \\ 0, & \text{if } r > n. \end{cases}$$

Proof. First, we prove the case $r \leq n$. We prove the statement by induction on r . It is enough to prove the following equality for $r < n$:

$$(1_{n-r} * \tilde{f}_{k_1} * \dots * \tilde{f}_{k_r}) \cdot (1_{n-1} * \tilde{f}_k) = 1_{n-r-1} * \tilde{f}_k * \tilde{f}_{k_1} * \tilde{f}_{k_2} * \dots * \tilde{f}_{k_r}.$$

We can rewrite this as the following diagrammatic identity in $eC(n\delta)e$:

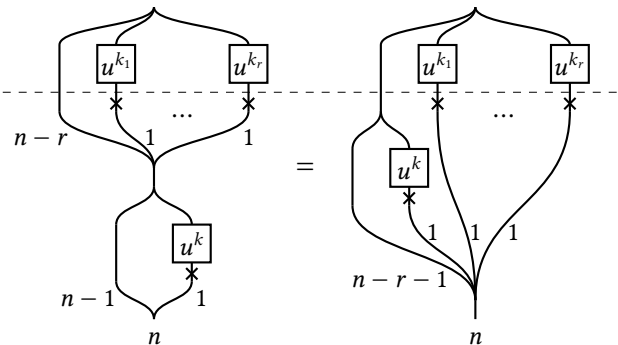
(35) 

where a cross on a strand stands for the polynomial $v-u$. It suffices to prove an equality of parts below the dashed line.

First, note that by Remark 7.9.(a) both pictures are equal in $eR(n\delta)e$ to some polynomials in $\text{Poll}_n^{(\mathbb{S}_\lambda)^2}$, where $\lambda = (n-r, 1, 1, \dots, 1)$. The left picture gives the polynomial

$$(v_{n-r+1} - u_{n-r+1}) \dots (v_n - u_n) D_n^u D_n^v \left[(v_1 - u_n)^2 \dots (v_{n-1} - u_n)^2 (v_n - u_n) u_n^k \right],$$

while the right picture gives

$$(v_{n-r+1} - u_{n-r+1}) \dots (v_n - u_n) D_{n-r}^u D_{n-r}^v [(u_{n-r} - v_1)^2 \dots (u_{n-r} - v_{n-r-1})^2 (u_{n-r} - v_{n-r}) u_{n-r}^k].$$

We want to show that the images of these polynomials in $e_\lambda C(n\delta) e_{(n)}$ coincide. By Remark 7.9.(b), it is enough to show that these polynomials are equal modulo the ideal generated by $(v_{n-r+1} - u_{n-r+1})^2, \dots, (v_n - u_n)^2$. Note that both polynomials already contain the factor $(v_{n-r+1} - u_{n-r+1}) \dots (v_n - u_n)$. Therefore, it is enough to prove the congruence

$$D_n^u D_n^v [(v_1 - u_n)^2 \dots (v_{n-1} - u_n)^2 (v_n - u_n) u_n^k] \equiv D_{n-r}^u D_{n-r}^v [(u_{n-r} - v_1)^2 \dots (u_{n-r} - v_{n-r-1})^2 (u_{n-r} - v_{n-r}) u_{n-r}^k]$$

modulo the ideal $(v_{n-r+1} - u_{n-r+1}, \dots, v_n - u_n)$. Indeed, we have

$$\begin{aligned} & D_n^u D_n^v [(v_1 - u_n)^2 \dots (v_{n-1} - u_n)^2 (v_n - u_n) u_n^k] \\ &= D_n^u D_{n-r}^v [(v_1 - u_n)^2 \dots (v_{n-r-1} - u_n)^2 (v_{n-r} - u_n) \dots (v_n - u_n) u_n^k] \\ &\equiv D_{n-r}^u D_{n-r}^v [(v_1 - u_{n-r})^2 \dots (v_{n-r-1} - u_{n-r})^2 (v_{n-r} - u_{n-r}) u_{n-r}^k]. \end{aligned}$$

Let us justify the congruence between the second and the third line above. Indeed, when we apply the sequence of Demazure operators $\partial_{n-r}^u \dots \partial_{n-1}^u$ to

$$u_n^k (v_1 - u_n)^2 \dots (v_{n-r-1} - u_n)^2 (v_{n-r} - u_n) \dots (v_n - u_n)$$

(the order is important!) and use the Leibniz rule $\partial_t^u(fg) = \partial_t^u(f)g + s_r^u(f)\partial_t^u(g)$, the only situation when the result is not in the ideal appears when ∂_{n-1}^u hits $(v_n - u_n)$ and applies s_{n-1}^u to the other factors, ∂_{n-2}^u hits $(v_{n-1} - u_{n-1})$ and applies s_{n-2}^u to the other factors, and so on.

Now, let us prove the case $r > n$. We need to show that $(\tilde{f}_{k_1} * \dots * \tilde{f}_{k_n}) \cdot (1_{n-1} * \tilde{f}_k) = 0$. For this, it is enough to show that the left hand side of (35) is zero in $eC(n\delta)e$ for $r = n$. This left hand side is given by the polynomial

$$(v_1 - u_1) \dots (v_n - u_n) D_n^u D_n^v [(v_1 - u_n)^2 \dots (v_{n-1} - u_n)^2 (v_n - u_n) u_n^k].$$

We have

$$D_n^u D_n^v [(v_1 - u_n)^2 \dots (v_{n-1} - u_n)^2 (v_n - u_n) u_n^k] = D^u [(v_1 - u_n) \dots (v_{n-1} - u_n) (v_n - u_n) u_n^k] \equiv 0.$$

The congruence is justified in the same way as in the previous case. \square

Corollary 7.29. *We have $\tilde{f}_{k_1} * \tilde{f}_{k_2} = \tilde{f}_{k_2} * \tilde{f}_{k_1}$ in $\text{Poll}_2^{(\mathbb{S}_2)^2} / J_2$.*

For each positive integer n , let us fix a basis \tilde{B}_n of $\mathbb{k}[u_1, \dots, u_n]^{\mathbb{S}_n}$.

Lemma 7.30. *The algebra $\text{Poll}_n^{(\mathbb{S}_n)^2} / J_n$ is spanned by the following set*

$$\{P * \tilde{f}_{k_1} * \tilde{f}_{k_2} * \dots * \tilde{f}_{k_r} : r \in [0, n], P \in \tilde{B}_{n-r}, 0 < k_1 \leq k_2 \leq \dots \leq k_r\}.$$

Proof. By Proposition 7.27, $\text{Poll}_n^{(\mathbb{S}_n)^2}$ is generated (as an algebra) by $\mathbb{k}[u_1, \dots, u_n]^{\mathbb{S}_n}$ and by the elements $\tilde{t}_{n,k}$ for $k \in \mathbb{Z}_{>0}$. Then Lemma 7.28 implies that $\text{Im } \varphi_n$ is generated as a $\mathbb{k}[u_1, \dots, u_n]^{\mathbb{S}_n}$ -module by elements of the form $1_{n-r} * \tilde{f}_{k_1} * \tilde{f}_{k_2} * \dots * \tilde{f}_{k_r}$. When we multiply $1_{n-r} * \tilde{f}_{k_1} * \tilde{f}_{k_2} * \dots * \tilde{f}_{k_r}$ by an element of $\mathbb{k}[u_1, \dots, u_n]^{\mathbb{S}_n}$, we get a linear combination of elements of the form $P * \tilde{f}_{k'_1} * \tilde{f}_{k'_2} * \dots * \tilde{f}_{k'_r}$, where $P \in \mathbb{k}[u_1, \dots, u_{n-r}]^{\mathbb{S}_{n-r}}$ and $k'_i \geq k_i$. Note that we can also reorder the factors using Corollary 7.29. This implies that the desired set spans $\text{Poll}_n^{(\mathbb{S}_n)^2} / J_n$. \square

From here until Section 7.9, let us assume that \mathbb{k} is either a field of characteristic 0 or \mathbb{Z} . Set $f_k = cx^{k-1} \in \mathbf{P}_1$ and $t_{n,k} = 1_{n-1} * f_k \in \mathbf{P}_n^{\mathbb{S}_n}$. Under φ_n , the basis \tilde{B}_n of $\mathbb{k}[u_1, \dots, u_n]^{\mathbb{S}_n}$ defines an analogous basis of $\mathbb{k}[x_1, \dots, x_n]^{\mathbb{S}_n}$, which we denote by the same symbol.

Lemma 7.31. *The following set is a \mathbb{k} -basis of $\text{Im } \varphi_n$:*

$$\mathcal{B} := \{P * f_{k_1} * f_{k_2} * \dots * f_{k_r} : r \in [0, n], P \in \tilde{B}_{n-r}, 0 < k_1 \leq k_2 \leq \dots \leq k_r\}.$$

Proof. The fact that the set \mathcal{B} spans $\text{Im } \varphi_n$ follows from Lemma 7.30 together with commutative square (33). Next, we prove linear independence. It is enough to do this for $\mathbb{k} = \mathbb{Q}$.

Let us choose a specific basis of $\mathbb{Q}[x_1, \dots, x_n]^{\mathfrak{S}_n}$. Namely, let

$$\mathcal{P}_n = \{\lambda = (\lambda_1, \dots, \lambda_n) \in \mathbb{Z}^n; 0 \leq \lambda_1 \leq \lambda_2 \leq \dots \leq \lambda_n\},$$

and write $B_n = \{m_\lambda : \lambda \in \mathcal{P}_n\}$, where $m_\lambda = \sum_{w \in \mathfrak{S}_n} x_{w(1)}^{\lambda_1} \dots x_{w(n)}^{\lambda_n}$ are the monomial symmetric functions.

For any $t \geq 0$, consider the element $e_t = x^t \in \mathbf{P}_1$. Then the set

$$\mathcal{B}' = \{e_{t_1} * e_{t_2} * \dots * e_{t_{n-r}} * f_{k_1} * f_{k_2} * \dots * f_{k_r}; r \in [0, n], 0 \leq t_1 \leq t_2 \leq \dots \leq t_{n-r}, 0 < k_1 \leq k_2 \leq \dots \leq k_r\}$$

is a basis in $\mathbf{P}_n^{\mathfrak{S}_n}$, see [FR20] for details. Consider a lexicographic order on \mathcal{B} , where $e_i > e_j$, $f_i > f_j$ for $i < j$, and $e_i > f_j$ for all i, j . Let $\lambda \in \mathcal{P}_n$. An easy induction argument shows that $1_n = \frac{1}{n!}(1 * 1 * \dots * 1)$. We can therefore write

$$m_\lambda = \frac{1}{n!}(1 * 1 * \dots * 1)m_\lambda = \frac{1}{n!} \sum_{w \in \mathfrak{S}_n} e_{\lambda_{w(1)}} * \dots * e_{\lambda_{w(n)}},$$

where we have used that $S_n^{1^n} \in \mathcal{S}_n$ commutes with any polynomial in $\mathbf{P}_n^{\mathfrak{S}_n}$. Next, we apply the reordering relations in [FR20, Theorem 1] to write m_λ in terms of \mathcal{B}' . We get

$$m_\lambda = e_{\lambda_1} * e_{\lambda_2} * \dots * e_{\lambda_n} + \text{lower terms.}$$

Similarly, for $\lambda \in \mathcal{P}_{n-r}$, we can write each element $m_\lambda * f_{k_1} * \dots * f_{k_r} \in \mathcal{B}$ as

$$m_\lambda * f_{k_1} * \dots * f_{k_r} = e_{\lambda_1} * e_{\lambda_2} * \dots * e_{\lambda_{n-r}} * f_{k_1} * \dots * f_{k_r} + \text{lower terms.}$$

Therefore the transition matrix from \mathcal{B} to \mathcal{B}' is upper triangular. This implies linear independence of \mathcal{B} . \square

7.8. Realization of $eC(n\delta)e$ inside \mathcal{S}_n .

Lemma 7.32. *We have $J_n = \text{Ker } \varphi_n$.*

Proof. The inclusion $J_n \subset \text{Ker } \varphi_n$ follows from diagram (33). Next, the map $\text{Poll}_n^{(\mathfrak{S}_n)^2} / J_n \rightarrow \mathbf{P}_n^{\mathfrak{S}_n}$ induced by φ_n takes the generating set of $\text{Poll}_n^{(\mathfrak{S}_n)^2} / J_n$ from Lemma 7.30 to the basis of $\text{Im } \varphi_n$ from Lemma 7.31. This implies that this map is injective, so that $J_n = \text{Ker } \varphi_n$. \square

Fix $\lambda \in \text{Comp}(n)$. Denote by J_λ the kernel of the map $\iota_\lambda : \text{Poll}_n^{(\mathfrak{S}_\lambda)^2} \rightarrow eC(n\delta)e$, which sends P to $e_\lambda P e_\lambda$.

Corollary 7.33. *We have $J_\lambda = \text{Ker } \varphi_\lambda$.*

Proof. Thanks to Proposition 7.23, we have the following commutative diagram:

$$\begin{array}{ccc} \text{Poll}_n^{(\mathfrak{S}_\lambda)^2} & \xrightarrow{\varphi_\lambda} & \mathbf{P}_n^{\mathfrak{S}_\lambda} \\ \downarrow \iota_\lambda & & \downarrow \\ eC(n\delta)e & \xrightarrow{\Phi_n} & \mathcal{S}_n \end{array}$$

Since the rightmost vertical map is injective, it follows that $J_\lambda \subset \text{Ker } \varphi_\lambda$.

Let us prove the opposite inclusion. Write $\lambda = (\lambda_1, \dots, \lambda_k)$. By definition of $C(n\delta)$, the map ι_λ can be written as a composition

$$\text{Poll}_n^{(\mathfrak{S}_\lambda)^2} \xrightarrow{\iota_{\lambda_1} \otimes \dots \otimes \iota_{\lambda_k}} \bigotimes_i eC(\lambda_i \delta) e \xrightarrow{\otimes} eC(n\delta) e.$$

On the other hand, we have $\varphi_\lambda = \varphi_{\lambda_1} \otimes \varphi_{\lambda_2} \otimes \dots \otimes \varphi_{\lambda_k}$ by Corollary 7.20, so that

$$\text{Ker } \varphi_\lambda = \left(\text{Ker } \varphi_{\lambda_1} \otimes \text{Poll}_{\lambda_2}^{(\mathfrak{S}_{\lambda_2})^2} \otimes \dots \otimes \text{Poll}_{\lambda_k}^{(\mathfrak{S}_{\lambda_k})^2} \right) + \dots + \left(\text{Poll}_{\lambda_1}^{(\mathfrak{S}_{\lambda_1})^2} \otimes \text{Poll}_{\lambda_2}^{(\mathfrak{S}_{\lambda_2})^2} \otimes \dots \otimes \text{Ker } \varphi_{\lambda_k} \right).$$

Now, the inclusion $\text{Ker } \varphi_\lambda \subset J_\lambda$ follows from Lemma 7.32. \square

Remark 7.34. In view of Corollary 7.33, the statement of Corollary 7.13 remains true if we replace $B_{i'_\lambda}$ by a basis of $\text{Poll}_n^{(\mathfrak{S}_{\lambda'})^2} / \text{Ker } \varphi_{\lambda'}$. Note also that $\text{Poll}_n^{(\mathfrak{S}_{\lambda'})^2} / \text{Ker } \varphi_{\lambda'} \simeq \text{Im } \varphi_{\lambda'}$ is free over \mathbb{k} by Lemma 7.31.

Proposition 7.35. *Let \mathbb{k} be a field of characteristic zero or $\mathbb{k} = \mathbb{Z}$. Then Φ_n is injective and its image is spanned by split/merge diagrams, whose strands of thickness k are decorated by elements of $\text{Im } \varphi_k \subset P_k^{\otimes k}$. In particular, if \mathbb{k} is a field of characteristic zero, then Φ_n is bijective.*

Proof. The statement about the image of Φ_n follows from Remark 7.14 and Proposition 7.23. For injectivity, note that Φ_n takes the spanning set of $eC(n\delta)e$ from Corollary 7.13 and Remark 7.34 to a linear independent set in \mathcal{S}_n , see Theorem 3.10. Therefore the spanning set of $eC(n\delta)e$ is automatically a basis, and Φ_n is injective. Finally, surjectivity in characteristic zero follows from Lemma 7.21. \square

Corollary 7.36. *The algebra $eC(n\delta)e$ is generated by elementary splits and merges, polynomial $(v - u)$ on thin strands, and symmetric polynomials $\mathbb{k}[u_1, \dots, u_k]^{\otimes k}$ on strands of thickness k .*

7.9. Counterexamples to injectivity/surjectivity of Φ_n . Let us begin by providing a certain geometric meaning for the image of φ_n .

Proposition 7.37. *Let $\mathbb{k} = \mathbb{Z}$. The H_{G_n} -submodule of $H^*(\mathcal{T}_n)$ generated by the tautological ring $TH^*(\mathcal{T}_n)$ coincides with the image of φ_n .*

Proof. By definition of the moduli stack $\text{Rep}_{n\delta} \Gamma$, equivariant parameters u_i, v_i are the Chern roots of the tautological vector bundles U, V respectively. In particular, restricting to \mathcal{T}_n we see that the image of φ_n is generated over \mathbb{Z} by the Chern classes of $\Gamma(\mathcal{E})$ and $\Gamma(\mathcal{E}(1))$.

Let us write $c^0(\mathcal{E}) = \sum_i c_{i,0}(\mathcal{E})$ and $c^1(\mathcal{E}) = \sum_i c_{i,1}(\mathcal{E})$; we have $c(\mathcal{E}) = c^0(\mathcal{E}) + c^1(\mathcal{E})p$. Since $p^2 = 0$, it follows from the definition of Chern character that $\text{ch}(\mathcal{E}) = \text{ch}^0(\mathcal{E}) + pQ$, where Q is some class in $H^*(\mathcal{T}_d)$, and $\text{ch}^0(\mathcal{E}) = \text{ch}(c^0(\mathcal{E}))$.

By Grothendieck-Riemann-Roch, we have $\text{ch}(\Gamma(\mathcal{E}(1))) - \text{ch}(\Gamma(\mathcal{E})) = \pi_* (\text{ch}(\mathcal{E}) \text{td}(\mathbb{P}^1)p) = \text{ch}^0(\mathcal{E})$, and so $c(\Gamma(\mathcal{E}(1))) = c(\Gamma(\mathcal{E}))c^0(\mathcal{E})$. Since the coefficients of $c(\Gamma(\mathcal{E}))$ are precisely the generators of H_{G_n} , we conclude that $\text{Im } \varphi_n \subset H_{G_n} \cdot TH^*(\mathcal{T}_n)$.

On the other hand, applying ε to the standard resolution of the path algebra of Γ (see [BK99, (1.2)]) produces the following resolution of \mathcal{E} :

$$0 \rightarrow \Gamma(\mathcal{E}(-1)) \otimes H^0(\mathcal{O}(1)) \otimes \mathcal{O} \rightarrow \Gamma(\mathcal{E}(-1)) \otimes \mathcal{O}(1) \oplus \Gamma(\mathcal{E}) \otimes \mathcal{O} \rightarrow \mathcal{E} \rightarrow 0.$$

In particular, we have

$$(36) \quad c(\mathcal{E}) = \frac{c(\Gamma(\mathcal{E}))c(\Gamma(\mathcal{E}(-1)) \otimes \mathcal{O}(1))}{c(\Gamma(\mathcal{E}(-1)))^2} = \frac{c(\Gamma(\mathcal{E}))}{c(\Gamma(\mathcal{E}(-1)) \otimes \mathcal{O}(-1))}.$$

The denominator is a polynomial in the Chern classes of $\Gamma(\mathcal{E}(-1))$ and $p \in H^2(\mathbb{P}^1)$. Moreover, we have $c(\Gamma(\mathcal{E}(-1))) = c(\Gamma(\mathcal{E}))^2 / c(\Gamma(\mathcal{E}(1)))$. Therefore the formula (36) shows that the Künneth-Chern classes $c_{i,j}(\mathcal{E})$ are expressed as polynomials of the Chern classes of $\Gamma(\mathcal{E})$ and $\Gamma(\mathcal{E}(1))$. Thus $H_{G_n} \cdot TH^*(\mathcal{T}_n) \subset \text{Im } \varphi_n$, and we may conclude. \square

Now let $\mathbb{k} = \mathbb{Z}$, and consider the map $\varphi_2 : \mathbb{Z}[u_1, u_2, v_1, v_2]^{\otimes 2} \rightarrow (\mathbb{Z}[x_1, x_2, c_1, c_2] / (c_1^2, c_2^2))^{\otimes 2}$. The element $c_1 c_2$ does not lie in $\text{Im } \varphi_2$ by Example 5.7 and Proposition 7.37. However, note that $2c_1 c_2 = (c_1 + c_2)^2 = \varphi_2((v_1 + v_2 - u_1 - u_2)^2) \in \text{Im } \varphi_2$.

Non-surjectivity of φ_2 automatically implies non-surjectivity of Φ_2 . Indeed, $\text{Im } \varphi_2 \subset \mathbb{P}_2^{\otimes 2}$ can be identified with $\text{Im } \Phi_2 \cap e_{(2)}\mathcal{S}_2 e_{(2)} \simeq \mathbb{P}_2^{\otimes 2}$. Moreover, applying universal coefficients we obtain that Φ_2 is not surjective if $\mathbb{k} = \mathbb{F}_2$.

Lemma 7.38. *For $\mathbb{k} = \mathbb{F}_2$ we have $J_2 \subsetneq \text{Ker } \varphi_2$.*

Proof. The inclusion $J_2 \subset \text{Ker } \varphi_2$ holds by the same argument as in Lemma 7.32. Let us show that this inclusion is strict. First, note that both J_2 and $\text{Ker } \varphi_2$ are homogeneous ideals in $\text{Poll}_2^{\otimes 2}$. Let us add the base ring (\mathbb{Z} or \mathbb{F}_p) to our notation as a superscript. Since $\varphi_2((v_1 + v_2 - u_1 - u_2)^2) = 2c_1 c_2 = 0$ over \mathbb{F}_2 , the ideal $\text{Ker } \varphi_2^{\mathbb{F}_2}$ contains a generator of degree 2. Thus in order to prove that the inclusion $J_2^{\mathbb{F}_2} \subset \text{Ker } \varphi_2^{\mathbb{F}_2}$ is strict, it suffices to show that $J_2^{\mathbb{F}_2}$ is generated by elements of degrees strictly greater than 2.

Since $\text{Ker}(eR_{\mathbb{F}_2}(n\delta)e \rightarrow eC_{\mathbb{F}_2}(n\delta)e)$ is clearly the reduction modulo 2 of $\text{Ker}(eR_{\mathbb{Z}}(n\delta)e \rightarrow eC_{\mathbb{Z}}(n\delta)e)$, we deduce that $J_2^{\mathbb{F}_2}$ is reduction modulo 2 of $J_2^{\mathbb{Z}}$. So, in order to show that $J_2^{\mathbb{F}_2}$ is generated by elements of degrees greater than 2, it is enough to show the same for $J_2^{\mathbb{Z}}$. At the same time we know that

$J_2^{\mathbb{Z}} = \text{Ker } \varphi_2^{\mathbb{Z}}$, and it is easy to check that $\text{Ker } \varphi_2^{\mathbb{Z}}$ has no elements of degree 1 or 2. This completes the proof. \square

The lemma above implies that Φ_2 is not injective for $\mathbb{k} = \mathbb{F}_2$. Indeed, take $P \in (\text{Ker } \varphi_2 \setminus J_2) \subset \text{Poll}_2^{(\mathbb{S}_2)^2}$. Then $P e_{(2)}$ is a non-zero element in $eC(2\delta)e$ that lies in the kernel of Φ_2 .

7.10. Positive characteristic. We have seen that the map $\Phi_n^{\mathbb{k}} : eC_{\mathbb{k}}(n\delta)e \rightarrow \mathcal{S}_n^{\mathbb{k}}$ is an isomorphism when \mathbb{k} is a field of characteristic zero. However, in general this map is neither injective nor surjective over a field of positive characteristic, as we have seen in Section 7.9. This behavior is explained by non-surjectivity of $\Phi_n^{\mathbb{Z}}$, because $\Phi_n^{\mathbb{k}}$ is obtained from $\Phi_n^{\mathbb{Z}}$ by base change $\mathbb{k} \otimes_{\mathbb{Z}} -$.

Let $\tilde{\mathcal{S}}_n^{\mathbb{Z}} := \text{Im } \Phi_n^{\mathbb{Z}} \subset \mathcal{S}_n^{\mathbb{Z}}$. Proposition 7.35 implies that $\tilde{\mathcal{S}}_n^{\mathbb{Z}}$ is a sublattice of full rank. Now, for any field \mathbb{k} define $\tilde{\mathcal{S}}_n^{\mathbb{k}} := \mathbb{k} \otimes_{\mathbb{Z}} \tilde{\mathcal{S}}_n^{\mathbb{Z}}$. The following theorem follows immediately from Proposition 7.35.

Theorem 7.39. *Let \mathbb{k} be a field. We have an isomorphism of algebras $eC_{\mathbb{k}}(n\delta)e \simeq \tilde{\mathcal{S}}_n^{\mathbb{k}}$.*

When $\text{char } \mathbb{k} = 0$, we have $\tilde{\mathcal{S}}_n^{\mathbb{k}} = \mathcal{S}_n^{\mathbb{k}}$; however, the two algebras are quite different in general. The algebra $\tilde{\mathcal{S}}_n^{\mathbb{k}}$ is rather explicit: it has nice diagrammatic description and an explicit basis. Moreover, the action of $\tilde{\mathcal{S}}_n^{\mathbb{Z}}$ on the polynomial representation $P_n^{\mathbb{Z}}$ preserves the \mathbb{Z} -submodule $\tilde{P}_n^{\mathbb{Z}} := \bigoplus_{\lambda} \text{Im } \varphi_{\lambda}$ by Proposition 7.23. In particular, we obtain a polynomial representation $\tilde{\mathcal{S}}_n^{\mathbb{k}} \curvearrowright \tilde{P}_n^{\mathbb{k}} := \mathbb{k} \otimes_{\mathbb{Z}} \tilde{P}_n^{\mathbb{Z}}$. We conjecture the following:

Conjecture 7.40. *The polynomial representation $\tilde{P}_n^{\mathbb{k}}$ of $\tilde{\mathcal{S}}_n^{\mathbb{k}}$ is faithful.*

In positive characteristic neither $\tilde{\mathcal{S}}_n^{\mathbb{k}}$ nor $\tilde{P}_n^{\mathbb{k}}$ has a concise geometric description, so the argument from the proof of Theorem 3.15 does not apply here. It would be interesting to realize $\tilde{\mathcal{S}}_n^{\mathbb{k}}$ as homology of some variety.

Example 7.41. Let us illustrate how properties of $\tilde{\mathcal{S}}_n^{\mathbb{F}_p}$ can change for different p . Let $n = 2$, and consider $2c_1c_2 \in \text{Im } \varphi_2^{\mathbb{Z}} \subset \tilde{P}_2^{\mathbb{Z}}$. It defines a non-zero element in the reduction $\tilde{P}_2^{\mathbb{F}_2}$ by previous considerations. Recall that we have the split operator $S = S_2^{(1,1)} \in \tilde{\mathcal{S}}_2^{\mathbb{Z}}$; we denote its reduction modulo 2 by the same letter. Note that $S(2c_1c_2) = 0 \in \tilde{P}_2^{\mathbb{F}_2}$, because tautologically $c_1c_2 \in \text{Im } \varphi_{(1,1)}^{\mathbb{Z}} = P_2^{\mathbb{Z}}$. This implies that $\tilde{P}_2^{\mathbb{F}_2}$ admits a non-trivial submodule supported completely on the thick string.

On the other hand, it is an easy exercise to verify that $\text{Im } \varphi_2^{\mathbb{Z}}$ together with c_1c_2 generate the whole $P_2^{\mathbb{S}_2}$ as a ring. Therefore $\tilde{\mathcal{S}}_2^{\mathbb{F}_p} = \mathcal{S}_2^{\mathbb{F}_p}$, $\tilde{P}_2^{\mathbb{F}_p} = P_2^{\mathbb{F}_p}$ for $p > 2$. However, the split operator S now acts on $P_2^{\mathbb{S}_2} \subset P_2^{\mathbb{F}_p}$ by embedding it into P_2 , so that no submodule of $P_2^{\mathbb{F}_p}$ can be supported solely on the thick string.

APPENDIX A. SEVERAL PARITY QUESTIONS

A.1. Parity of quiver flag varieties, type $A_1^{(1)}$. As before, let $\Gamma = 1 \rightrightarrows 0$ be the Kronecker quiver. Pick a representation $M = (U \rightrightarrows V) \in \text{Rep } \Gamma$ with dimension vector \mathbf{v} . For any increasing sequence of dimension vectors $\underline{\mathbf{v}} = (\mathbf{v}_1 < \dots < \mathbf{v}_k = \mathbf{v})$, consider the *quiver flag variety*

$$\mathbf{F}_{\underline{\mathbf{v}}}(M) = \{M_1 \subset \dots \subset M_k = M : \dim M_i = \mathbf{v}_i\}.$$

The goal of this section is to prove the following proposition:

Proposition A.1. *The flag variety $\mathbf{F}_{\underline{\mathbf{v}}}(M)$ has no odd cohomology groups.*

Before giving the proof, we will need some preparations. Let us say that Proposition A.1 holds for a representation M if we have $H^{\text{odd}}(\mathbf{F}_{\underline{\mathbf{v}}}(M), \mathbb{Z}) = 0$ for any $\underline{\mathbf{v}}$.

Recall (e.g., see [Sch12]) that isomorphism classes of indecomposable representations of Γ can be classified into three distinct families:

preprojective $P_n, n \geq 0$	regular $R_n^{(\lambda, \mu)}, n > 0, (\lambda, \mu) \in \mathbb{C}^2 \setminus \{0, 0\}$	preinjective $I_n, n \geq 0$
$\mathbb{C}^n \begin{array}{c} \xrightarrow{\begin{pmatrix} \text{id}_{\mathbb{C}^n} \\ 0 \end{pmatrix}} \\ \xrightarrow{\begin{pmatrix} 0 \\ \text{id}_{\mathbb{C}^n} \end{pmatrix}} \end{array} \mathbb{C}^{n+1}$	$\begin{array}{c} \mathbb{C}^n \xrightarrow{\begin{array}{c} \lambda \text{id}_{\mathbb{C}^n + L_n \\ \mu \text{id}_{\mathbb{C}^n + L_n} \end{array}} \mathbb{C}^n, \quad \lambda \neq \mu \\ \mathbb{C}^n \xrightarrow{\begin{array}{c} \lambda \text{id}_{\mathbb{C}^n} \\ \lambda \text{id}_{\mathbb{C}^n + L_n} \end{array}} \mathbb{C}^n \end{array}$	$\mathbb{C}^{n+1} \begin{array}{c} \xrightarrow{\begin{pmatrix} \text{id}_{\mathbb{C}^n} & 0 \\ 0 & \text{id}_{\mathbb{C}^n} \end{pmatrix}} \\ \xrightarrow{\begin{pmatrix} 0 \\ \text{id}_{\mathbb{C}^n} \end{pmatrix}} \end{array} \mathbb{C}^n$

Here, L_n denotes a nilpotent Jordan block of rank n .

Furthermore, for any $n, m \geq 0$ we have vanishing of Ext-groups:

$$\mathrm{Ext}^1(P_n, P_{n+m}) = \mathrm{Ext}^1(P_n, R_n^{(\lambda, \mu)}) = \mathrm{Ext}^1(P_n, I_m) = \mathrm{Ext}^1(R_n^{(\lambda, \mu)}, I_n) = \mathrm{Ext}^1(I_{n+m}, I_n) = 0.$$

Two representation of the form $R_n^{(\lambda, \mu)}$ are isomorphic if and only if they have the same n and the same ratio $(\lambda : \mu) \in \mathbb{P}^1$. We also have $\mathrm{Ext}^1(R_n^{(\lambda, \mu)}, R_m^{(\lambda', \mu')}) = 0$ for $(\lambda : \mu) \neq (\lambda' : \mu')$.

The following lemma is an immediate consequence of [Mak19, Proposition 2.17].

Lemma A.2. *Let M_1 and M_2 be two representations of Γ such that $\mathrm{Ext}^1(M_1, M_2) = 0$, and such that Proposition A.1 holds for M_1 and M_2 . Then Proposition A.1 also holds for $M_1 \oplus M_2$.*

Lemma A.3 ([Mak19, Theorem 3.4]). *Let M be a representation of Γ satisfying $\mathrm{Ext}^1(M, M) = 0$. Then Proposition A.1 holds for M .*

Remark A.4. The assumption $\mathrm{Ext}^1(M, M) = 0$ in [Mak19, Theorem 3.4] is only required in order to construct a certain vector bundle on $\mathbb{F}_{\mathbf{v}}(M) \times \mathbb{F}_{\mathbf{v}}(M)$ with a distinguished section, which vanishes exactly on the diagonal. This assumption can be slightly relaxed. Namely, it may happen that M has $\mathrm{Ext}^1(M, M) \neq 0$, but there exists another representation M' such that

- there exists an isomorphism of I -graded vector spaces $f : M \rightarrow M'$,
- for each \mathbf{v} , the isomorphism f induces an isomorphism of varieties $\mathbb{F}_{\mathbf{v}}(M) \simeq \mathbb{F}_{\mathbf{v}}(M')$,
- $\mathrm{Ext}^1(M, M') = 0$.

In this case [Mak19, Theorem 3.4] is still applicable, and Proposition A.1 holds for M . An example of such a situation is $M = R_n^{(\lambda, \mu)}$ and $M' = R_n^{(\lambda', \mu')}$ with $(\lambda : \mu) \neq (\lambda' : \mu')$. More generally, we can take $M = \bigoplus_{r=1}^k R_{a_r}^{(\lambda, \mu)}$ and $M' = \bigoplus_{r=1}^k R_{a_r}^{(\lambda', \mu')}$ with $(\lambda : \mu) \neq (\lambda' : \mu')$ for some positive integers a_1, \dots, a_k .

Proof of Proposition A.1. Any representation M can be decomposed as $M = P \oplus R \oplus I$ such that P is preprojective, R is regular and I is preinjective. Since $\mathrm{Ext}^1(P, R) = \mathrm{Ext}^1(R, I) = \mathrm{Ext}^1(P, I) = 0$, it is enough to prove the statement separately for P , R and I by Lemma A.2.

First, let us show that the theorem holds for a preprojective representation P . We know that P can be decomposed as $P = \bigoplus_{r=1}^k P_{a_r}$ for some $a_1, a_2, \dots, a_k \in \mathbb{Z}_{\geq 0}$. We have $\mathrm{Ext}^1(P_a, P_b) = 0$ for $a \leq b$. Applying Lemma A.3 and Lemma A.2, we see that Proposition A.1 holds for each P_{a_r} and then for P as well. The same argument also proves the statement for preinjective representations.

Now, let R be a regular representation. We can decompose R as $R = \bigoplus_{r=1}^k R^{(\lambda_r : \mu_r)}$, where $(\lambda_r : \mu_r) \in \mathbb{P}^1$ are different for different r 's, and $R^{(\lambda_r : \mu_r)}$ is isomorphic to a direct sum of representations of the form $R_n^{(\lambda_r, \mu_r)}$. Since $\mathrm{Ext}^1(R^{(\lambda_i : \mu_i)}, R^{(\lambda_j : \mu_j)}) = 0$ for $i \neq j$, it suffices to prove the statement for each $R^{(\lambda_r : \mu_r)}$. We conclude by applying Remark A.4. \square

A.2. Parity sheaves. The theory of parity sheaves has been developed in [JMW14]. It takes as an input a complex algebraic variety Y with an action of a complex algebraic group G , such that Y has a G -invariant stratification $Y = \coprod_{\lambda} Y_{\lambda}$ satisfying some parity conditions [JMW14, (2.1),(2.2)]. For each stratum Y_{λ} and a local system \mathcal{L} on Y_{λ} , it produces a certain indecomposable complex $\mathcal{E}(\lambda, \mathcal{L})$ supported on \overline{Y}_{λ} , which satisfies a list of properties. (This complex is not well-defined in general, but it is unique if it exists.)

The case $Y = E_{\alpha}$, $G = G_{\alpha}$ was studied in [Mak15] for a Dynkin quiver. In this situation, we have a finite stratification of E_{α} by G_{α} -orbits, and each stratum admits only trivial G_{α} -equivariant local systems. The existence of a parity sheaf for each stratum is then proved. However, [Mak15] did not prove that in positive characteristics the Lusztig sheaf $\mathcal{L}_{\alpha} = (\pi_{\alpha})_* \underline{\mathbb{k}}$ is a direct sum of shifts of parity sheaves. This was done later in [McN17a, Mak19]. The key point was to prove that the fibers of maps $\tilde{\mathbb{F}}_1 \rightarrow E_{\alpha}$ have no odd cohomology groups. Note that Proposition A.1 proves an analogous statement about the fibers for the Kronecker quiver.

Nevertheless, the proposition below shows that there is no satisfactory theory of parity sheaves for the Kronecker quiver, already for dimension vector $\alpha = 2\delta$. So, despite Proposition A.1, we cannot deduce in this case that the sheaf \mathcal{L}_{α} is a direct sum of shifts of parity sheaves.

Proposition A.5. *Let Γ be the Kronecker quiver. There is no algebraic stratification (in the sense of [CG10, Definition 3.2.23]) of $E_{2\delta}$ into smooth connected locally closed subsets such that each stratum is $G_{2\delta}$ -invariant and satisfies [JMW14, (2.1),(2.2)], and the subset $E_{2\delta}^{\mathrm{reg}} \subset E_{2\delta}$ is a union of strata.*

Proof. Suppose that such a stratification exists. The first two assumptions are simply the assumptions in [JMW14] that allow to apply the theory of parity sheaves. In particular, the constant sheaf $\underline{\mathbb{k}}$ on $E_{2\delta}$ is a parity sheaf (up to a shift).

Consider the inclusion map $\iota : E_{2\delta}^{\text{reg}} \rightarrow E_{2\delta}$. The third assumption together with the argument in [McN17a, Corollary 4.2] show that the map $\text{Ext}_{G_{2\delta}}^*(\underline{\mathbb{k}}, \underline{\mathbb{k}}) \rightarrow \text{Ext}_{G_{2\delta}}^*(\iota^*\underline{\mathbb{k}}, \iota^*\underline{\mathbb{k}})$ must be surjective. Recall that we have the following commutative diagram, where the horizontal maps are isomorphisms:

$$\begin{array}{ccccc} \mathbb{k}[u_1, u_2, v_1, v_2]^{\mathfrak{S}_2} & \longrightarrow & H_*^{G_{2\delta}}(E_{2\delta}) & \longrightarrow & \text{Ext}_{G_{2\delta}}^*(\underline{\mathbb{k}}, \underline{\mathbb{k}}) \\ \downarrow \varphi_2 & & \downarrow & & \downarrow \\ (\mathbb{k}[x_1, x_2, c_1, c_2]/(c_1^2, c_2^2))^{\mathfrak{S}_2} & \longrightarrow & H_*^{G_{2\delta}}(E_{2\delta}^{\text{reg}}) & \longrightarrow & \text{Ext}_{G_{2\delta}}^*(\iota^*\underline{\mathbb{k}}, \iota^*\underline{\mathbb{k}}) \end{array}$$

However, we have seen in Section 7.9 that the map φ_2 is not surjective for $\mathbb{k} = \mathbb{F}_2$. □

REFERENCES

- [AHR15] Pramod N. Achar, Anthony Henderson, and Simon Riche. Geometric Satake, Springer correspondence, and small representations II. *Represent. Theory*, 19:94–166, 2015.
- [ASS06] Ibrahim Assem, Daniel Simson, and Andrzej Skowroński. *Elements of the representation theory of associative algebras. Vol. 1*, volume 65 of *London Mathematical Society Student Texts*. Cambridge University Press, Cambridge, 2006. Techniques of representation theory.
- [Ati57] Michael Atiyah. Vector Bundles Over an Elliptic Curve. *Proceedings of the London Mathematical Society*, s3-7(1):414–452, 1957.
- [Bei78] Alexander A. Beilinson. Coherent sheaves on \mathbb{P}^n and problems of linear algebra. *Funct. Anal. Its Appl.*, 12(3):214–216, July 1978.
- [Bia73] Andrzej Białynicki-Birula. Some Theorems on Actions of Algebraic Groups. *The Annals of Mathematics*, 98(3):480, November 1973.
- [BK99] Michael C. Butler and Alastair D. King. Minimal Resolutions of Algebras. *J. Algebra*, 212(1):323–362, 1999.
- [BN15] David Ben-Zvi and David Nadler. Elliptic Springer Theory. *Compositio Math.*, 151(8):1568–1584, August 2015.
- [BS12] Igor Burban and Olivier Schiffmann. On the Hall algebra of an elliptic curve, I. *Duke Mathematical Journal*, 161(7):1171–1231, 2012.
- [CG10] Neil Chriss and Victor Ginzburg. *Representation Theory and Complex Geometry*. Birkhäuser Basel, 2010.
- [Dem73] Michel Demazure. Invariants symétriques entiers des groupes de Weyl et torsion. *Invent. Math.*, 21:287–301, 1973.
- [FM81] William Fulton and Robert MacPherson. Categorical framework for the study of singular spaces. *Mem. Amer. Math. Soc.*, 31(243):vi+165, 1981.
- [FMW98] Robert Friedman, John W. Morgan, and Edward Witten. Principal g -bundles over elliptic curves. *Mathematical Research Letters*, 5(1):97–118, 1998.
- [FR20] Hans Franzen and Markus Reineke. On the cohomological Hall algebra of the Kronecker quiver. In *Representation theory and beyond*, volume 758 of *Contemp. Math.*, pages 213–225. Amer. Math. Soc., [Providence], RI, 2020.
- [Ful97] William Fulton. *Young tableaux*, volume 35 of *London Mathematical Society Student Texts*. Cambridge University Press, Cambridge, 1997. With applications to representation theory and geometry.
- [Ful98] William Fulton. *Intersection Theory*, volume 2 of *Ergebnisse Der Mathematik Und Ihrer Grenzgebiete. 3. Folge. A Series of Modern Surveys in Mathematics [Results in Mathematics and Related Areas. 3rd Series. A Series of Modern Surveys in Mathematics]*. Springer-Verlag, Berlin, second edition, 1998.
- [GPHS14] Oscar García-Prada, Jochen Heinloth, and Alexander Schmitt. On the motives of moduli of chains and Higgs bundles. *J. Eur. Math. Soc. (JEMS)*, 16(12):2617–2668, 2014.
- [Gre95] James A. Green. Hall algebras, hereditary algebras and quantum groups. *Invent. Math.*, 120(1):361–377, December 1995.
- [Hei12] Jochen Heinloth. Cohomology of the moduli stack of coherent sheaves on a curve. In Carel Faber, Gavril Farkas, and Robin de Jong, editors, *Geometry and Arithmetic*, pages 165–171. European Mathematical Society Publishing House, Zuerich, Switzerland, October 2012.
- [HS09] Tara Holm and Reyer Sjamaar. Torsion and abelianization in equivariant cohomology. *Transform. Groups*, 13(3-4):585–615, June 2009.
- [Hsi75] W. Y. Hsiang. *Cohomology Theory of Topological Transformation Groups*. Ergebnisse Der Mathematik Und Ihrer Grenzgebiete. 2. Folge. Springer-Verlag, Berlin Heidelberg, 1975.
- [JMW14] Daniel Juteau, Carl Mautner, and Geordie Williamson. Parity sheaves. *J. Amer. Math. Soc.*, 27(4):1169–1212, 2014.
- [KL09] Mikhail Khovanov and Aaron D. Lauda. A diagrammatic approach to categorification of quantum groups I. *Represent. Theory*, 13:309–347, 2009.
- [Kle15] Alexander S. Kleshchev. Affine highest weight categories and affine quasihereditary algebras. *Proceedings of the London Mathematical Society*, 110(4):841–882, April 2015.
- [KM17a] Alexander Kleshchev and Robert Muth. Imaginary Schur-Weyl duality. *Mem. Amer. Math. Soc.*, 245(1157):xvii+83, 2017.

- [KM17b] Alexander Kleshchev and Robert Muth. Stratifying KLR algebras of affine ADE types. *Journal of Algebra*, 475:133–170, April 2017.
- [KM19] Alexander Kleshchev and Robert Muth. Affine zigzag algebras and imaginary strata for KLR algebras. *Trans. Amer. Math. Soc.*, 371(7):4535–4583, 2019.
- [LP97] Joseph Le Potier. *Lectures on Vector Bundles*, volume 54 of *Cambridge Studies in Advanced Mathematics*. Cambridge University Press, Cambridge, 1997.
- [Mak15] Ruslan Maksimau. Canonical basis, KLR algebras and parity sheaves. *Journal of Algebra*, 422:563–610, January 2015.
- [Mak19] Ruslan Maksimau. Flag versions of quiver Grassmannians for Dynkin quivers have no odd cohomology over \mathbb{Z} . *arXiv:1909.04907 [math]*, September 2019.
- [McN17a] Peter J. McNamara. Representation theory of geometric extension algebras. *arXiv:1701.07949 [math]*, 2017.
- [McN17b] Peter J. McNamara. Representations of Khovanov-Lauda-Rouquier algebras III: Symmetric affine type. *Math. Z.*, 287(1-2):243–286, 2017.
- [Min20] Alexandre Minets. Cohomological Hall algebras for Higgs torsion sheaves, moduli of triples and sheaves on surfaces. *Selecta Math. (N.S.)*, 26(2):Paper No. 30, 67, 2020.
- [MS17] Hugh Morton and Peter Samuelson. The HOMFLYPT skein algebra of the torus and the elliptic Hall algebra. *Duke Mathematical Journal*, 166(5):801–854, April 2017.
- [Neg14] Andrei Neguț. The shuffle algebra revisited. *International Mathematics Research Notices*, 2014(22):6242–6275, 2014.
- [Prz19] Tomasz Przedziecki. Quiver Schur algebras and cohomological Hall algebras. *arXiv:1907.03679 [math]*, July 2019.
- [Rin90] Claus Michael Ringel. Hall algebras and quantum groups. *Invent. Math.*, 101(1):583–591, December 1990.
- [Rou08] Raphael Rouquier. 2-Kac-Moody algebras. *arXiv:0812.5023 [math]*, December 2008.
- [Rou12] Raphael Rouquier. Quiver Hecke algebras and 2-Lie algebras. *Algebra Colloq.*, 19(2):359–410, 2012.
- [Sav18] Alistair Savage. Affine wreath product algebras. *International Mathematics Research Notices*, May 2018.
- [Sch12] Olivier Schiffmann. Lectures on Hall algebras. In *Geometric Methods in Representation Theory. {III}*, volume 24 of *Sémin. Congr.*, pages 1–141. Soc. Math. France, Paris, 2012.
- [SV13] Olivier Schiffmann and Eric Vasserot. The elliptic Hall algebra and the equivariant k -theory of the Hilbert scheme of \mathbb{A}^2 . *Duke Mathematical Journal*, 162(2):279–366, 2013.
- [SVV19] Peng Shan, Michela Varagnolo, and Eric Vasserot. Coherent categorification of quantum loop algebras : The $sl(2)$ case. *arXiv:1912.03325 [math]*, December 2019.
- [SW14] Catharina Stroppel and Ben Webster. Quiver Schur algebras and q -Fock space. *arXiv:1110.1115 [math]*, July 2014.
- [VV11] Michela Varagnolo and Eric Vasserot. Canonical bases and KLR-algebras. *J. reine angew. Math.*, 659:67–100, 2011.
- [Wey39] Hermann Weyl. *The Classical Groups: Their Invariants and Representations*. Princeton University Press, 1939.

INSTITUT MONTPELLIÉRAIN ALEXANDER GROTHENDIECK, UNIVERSITÉ DE MONTPELLIER, FRANCE
 LABORATOIRE ANALYSE GÉOMÉTRIE MODÉLISATION, CY CERGY PARIS UNIVERSITÉ, FRANCE
 Email address: ruslan.maksimau@umontpellier.fr, ruslmax@gmail.com

UNIVERSITY OF EDINBURGH, UNITED KINGDOM
 Email address: alexandre.minets@ed.ac.uk