



HAL
open science

MUSE Alignment onto VLT

Florence Laurent, Edgard Renault, Didier Boudon, Patrick Caillier, Eric Daguisé, Christophe Dupuy, Aurélien Jarno, Jean-Louis Lizon, Jean-Emmanuel Migniau, Harald Nicklas, et al.

► **To cite this version:**

Florence Laurent, Edgard Renault, Didier Boudon, Patrick Caillier, Eric Daguisé, et al.. MUSE Alignment onto VLT. SPIE Astronomical Telescopes + Instrumentation, Jun 2014, Montréal, France. pp.915112, 10.1117/12.2057075 . hal-04785500

HAL Id: hal-04785500

<https://hal.science/hal-04785500v1>

Submitted on 15 Nov 2024

HAL is a multi-disciplinary open access archive for the deposit and dissemination of scientific research documents, whether they are published or not. The documents may come from teaching and research institutions in France or abroad, or from public or private research centers.

L'archive ouverte pluridisciplinaire **HAL**, est destinée au dépôt et à la diffusion de documents scientifiques de niveau recherche, publiés ou non, émanant des établissements d'enseignement et de recherche français ou étrangers, des laboratoires publics ou privés.

MUSE Alignment onto VLT

Florence Laurent^{*a}, Edgard Renault^a, Didier Boudon^a, Patrick Caillier^a, Eric Daguisé^a, Christophe Dupuy^b, Aurélien Jarno^a, Jean-Louis Lizon^b, Jean-Emmanuel Migniau^a, Harald Nicklas^c, Laure Piqueras^a

^aUniversité de Lyon, Lyon, F-69003, France; Université Lyon 1, Observatoire de Lyon, 9 avenue Charles André, Saint-Genis Laval, F-69230, France; CNRS, UMR 5574, Centre de Recherche Astrophysique de Lyon; Ecole Normale Supérieure de Lyon, Lyon, F-69007, France; ^bESO, Karl-Schwarzschild-Str. 2, D-85748 Garching bei München, Germany; ^cInstitut für Astrophysik, Georg-August-Universität, 37077 Göttingen, Germany

ABSTRACT

MUSE (Multi Unit Spectroscopic Explorer) is a second generation Very Large Telescope (VLT) integral field spectrograph developed for the European Southern Observatory (ESO). It combines a 1' x 1' field of view sampled at 0.2 arcsec for its Wide Field Mode (WFM) and a 7.5"x7.5" field of view for its Narrow Field Mode (NFM). Both modes will operate with the improved spatial resolution provided by GALACSI (Ground Atmospheric Layer Adaptive Optics for Spectroscopic Imaging), that will use the VLT deformable secondary mirror and 4 Laser Guide Stars (LGS) foreseen in 2015. MUSE operates in the visible wavelength range (0.465-0.93 μm). A consortium of seven institutes is currently commissioning MUSE in the Very Large Telescope for the Preliminary Acceptance in Chile, scheduled for September, 2014.

MUSE is composed of several subsystems which are under the responsibility of each institute. The Fore Optics derotates and anamorphoses the image at the focal plane. A Splitting and Relay Optics feed the 24 identical Integral Field Units (IFU), that are mounted within a large monolithic structure. Each IFU incorporates an image slicer, a fully refractive spectrograph with VPH-grating and a detector system connected to a global vacuum and cryogenic system. During 2012 and 2013, all MUSE subsystems were integrated, aligned and tested to the P.I. institute at Lyon. After successful PAE in September 2013, MUSE instrument was shipped to the Very Large Telescope in Chile where that was aligned and tested in ESO integration hall at Paranal. After, MUSE was directly transported, fully aligned and without any optomechanical dismounting, onto VLT telescope where the first light was overcome the 7th of February, 2014.

This paper describes the alignment procedure of the whole MUSE instrument with respect to the Very Large Telescope (VLT). It describes how 6 tons could be move with accuracy better than 0.025mm and less than 0.25 arcmin in order to reach alignment requirements. The success of the MUSE alignment is demonstrated by the excellent results obtained onto MUSE image quality and throughput directly onto the sky.

Keywords: Optical alignment, VLT, MUSE instrument

1. INTRODUCTION

Built for the European Southern Observatory (ESO) for the second generation VLT instrumentation, MUSE (Multi Unit Spectrograph Explorer) is installed on the Very Large Telescope (VLT), Unit Telescope 4 (UT4), Nasmyth platform B for its first light the 7th of February, 2014. MUSE is an innovative Integral Field Unit (IFU), which combines a 1'x1' Field of View (FoV), with a spectral resolution reaching 3000 and a spatial sampling of 0.2'' matching the spatial resolution provided by a ground layer adaptive optics system named GALACSI. MUSE operates in a large visible spectral range (0.465 – 0.93 μm) with 2 functional modes a Wide Field Mode (WFM) and a Narrow Field Mode (NFM) where the latter has an eight times higher spatial resolution - [1].

*florence.laurent@univ-lyon1.fr; phone 33 4 78 86 85 33; fax 33 4 78 86 83 86; <http://cral.univ-lyon1.fr/>

The MUSE instrument is composed of a Calibration Unit, a Fore-Optic which includes an optical derotator and an anamorphoser by 2, a splitting optics cutting the FoV in 24 parts and 24 relay optics which feed 24 identical IFU. Each IFU is composed of an original advanced image slicer associated with a high-throughput spectrograph with a Volume Phase Holographic Grating (VPHG) and a 4k×4k CCD detector.

This paper describes the opto-mechanical alignment procedure of the MUSE instrument with respect to VLT performed in Paranal. The aims are to:

- Define the alignment requirements,
- Depict MUSE alignment references,
- Explain MUSE degrees of freedom which allow to move 6 tons with an accuracy better than 0.025mm and 0.25 arcmin,
- Describe the tools used to perform the alignment,
- Detail VLT-UT4 measurement which allow to set the telescope at nominal position for MUSE alignment,
- Set out the alignment procedure and its internal results,
- Check this alignment directly onto the sky through MUSE instrument.

2. MUSE DESCRIPTION

To achieve the system performances, MUSE optomechanical design is divided into 5 main subsystems as shown in Figure 1 - [5].

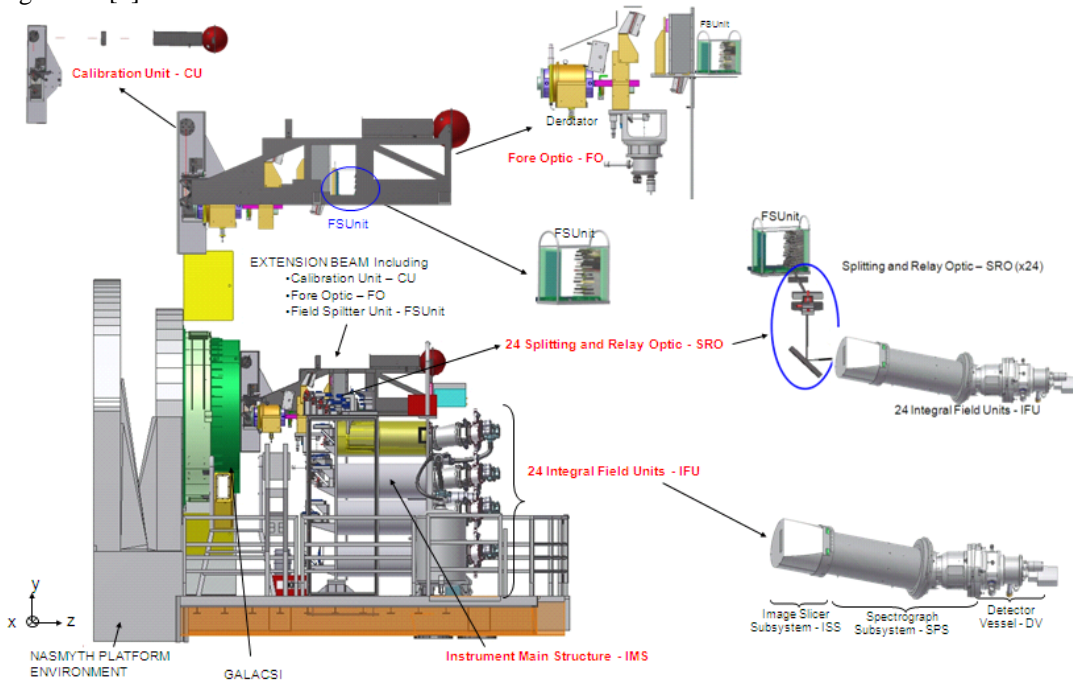

Figure 1: MUSE Mechanical Overview

The MUSE Adaptive Optics (AO) is GALACSI [2] (Ground Atmospheric Layer Adaptive Corrector for Spectroscopic Imaging). GALACSI will be built by the ESO AO Department for its installation at Paranal in 2015. The interface between MUSE and GALACSI is a pure optical interface and that there is no mechanical link between them.

The Instrument Main Structure IMS [6] is the central mechanical link between the UT4-VLT Nasmyth platform and all MUSE optical sub-systems i.e. Splitting and Relay Optics, the 24 IFUs and the Extension Beam where the Fore-Optics and the Calibration Unit are set. To ensure the link between MUSE and Nasmyth platform, three quasi-kinematic mounts i.e. three flexure joints are chosen in order to absorb non-planarity effects of the Nasmyth platform. The fixation of these three supports contains adjustment which allows accurate alignment for the whole MUSE instrument.

The Calibration Unit (CU) [3] simulates the VLT beam f-number and the VLT focal plane. That provides a Flat Field, all the light sources for flatfield illumination and spectral calibration of the WFM and NFM and several field masks. The 2 main references of MUSE internal alignment are located onto the CU:

- A reference pinhole which mimics the FoV centre (§ 6.1),
- A single hole located onto telescope pupil (§ 6.2).

The Fore-Optics (FO) [7] performs the following functions:

- To switch between the 2 MUSE modes: WFM and NFM,
- To transform a rotating square Field of View (FoV), from the telescope, into a static FoV at the entrance of the Splitter and Relay Optics sub-system,
- To anamorphose by a factor by 2 the FoV,
- To compensate for the atmospheric dispersion in NFM,
- To filter the undesirable wavelengths to avoid second order pollution and /or Laser Guide Star pollution,
- To start/end the exposure (Instrument Main Shutter),
- To maintain the relative positioning of MUSE and GALACSI with two metrology system, one called ‘WFM Slow Guiding System (SGS)’ in Wide Field Mode (WFM) and another IRLOS “IR Low Order Sensor” in Narrow Field Mode (NFM).

A tool, named Pupil and Image Check (PIC) is located onto the Fore-Optic (§ 8.3). It sights both pupil and image in using the focusing capability of the objective. It stays in the instrument during its lifetime to periodically check the positioning of MUSE at Nasmyth focus or after an earthquake.

The goal of the Splitting and Relay Optics (SRO) [6] is:

- To split the output Fore Optics FoV in 24 subFoVs - [10],
- To magnify each subFoV from the FO output to each IFU,
- To image the VLT pupil at the entrance of the Integral Field Unit.

This system is replicated 24 times except for splitting part.

The Integral Field Units (IFU), which is replicated 24 times, is composed of 3 main subsystems:

- Image Slicer Sub-system (ISS) which has 2 functions :
 - To transform a rectangular FoV into a serie of 48 mini “slits” that are re-arranged along a pseudo-slit, which will be located at the entrance of a spectrograph,
 - To image the input pupil (itself being an image of the VLT pupil) at the entrance pupil of the spectrograph.
- Spectrograph (SPS):
 - To disperse the pseudo slit over the MUSE wavelength bandwidth and with the specified resolution,
 - To image the FoV onto CCD chip.
- Instrument Detector System (IDS) which acquires and records 4kx4k CCD chip of 15 μ m pixel square in a raw exposure - [4] and [8]. All detectors are connected to a global vacuum and cryogenic system.

3. STRATEGY

In Europe and Paranal, the alignment philosophy of the MUSE instrument was the same. It consists to:

- Use internal references which mimic the FoV and Pupil onto the MUSE Calibration Unit.
- Align and test all subsystems before their integration onto MUSE instrument,
- Align the whole MUSE wrt the telescope using the internal references,
- Maximize Encircled Energy performance in compliance with vignetting avoidance. Best EE performance is verified by optical performance measurements after each subsystem integration at interface plane.

All subsystems and MUSE were already aligned and tested in Lyon premises [12]. In Europe, a telescope simulator has been developed in order to develop and test the MUSE global alignment procedure. The Preliminary Acceptance in Europe (PAE) was successful in September, 2013. In Paranal, MUSE was aligned and tested subsystem by subsystem in the Paranal integration hall following the same philosophy as Lyon [12]. After successful tests in January, 2014, MUSE was transported, fully aligned and without any optomechanical dismounting onto VLT telescope [11]. MUSE was installed onto UT4-VLT Nasmyth platform B into its adjustment range in order to start the fine alignment wrt the telescope (Figure 2). This alignment is described in next sections.



Figure 2: Left: MUSE during the transport between Paranal integration hall and U-Telescope. Middle: MUSE launch and land on UT4. Right: MUSE installed onto UT4.

4. COORDINATE SYSTEMS

4.1 VLT Coordinate System

4.1.1 VLT Coordinate System

The coordinate system used for one Unit Telescope is (Figure 3):

- O is at the intersection between altitude and azimuth axis,
- Z points towards the Zenith,
- Y points towards the South,
- X points towards the West.

The altazimuthal coordinate frame rotates about the z-axis, respectively x-axis, with respect to the telescope coordinates that corresponds to the telescope azimuth angle, respectively altitude angle.

The altitude angle is directly above (or below) the horizon. Altitude is the complement of the zenith angle. That is, zenith angle plus altitude equals 90 degrees. The Azimuth angle measures clockwise (eastward) from north to the point on the horizon directly below (or above) the object. The south has chosen as the point of zero azimuth.

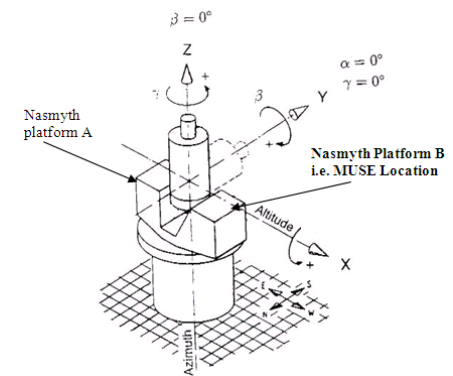

Figure 3: Orientation of the telescope coordinates

4.1.2 VLT FoV Reference

The global coordinate system of VLT (OXYZ) is fixed to the nominal focus of the output beam of VLT and stable with respect to the gravity vector (Figure 4), where:

- O is at the center of the Nasmyth Adaptor Rotator (NAR) inner bore at the level of the Instrument Attachment Flange interface surface, translated along Z direction by 500 mm. It represents the theoretical location of the center of the Nasmyth focus.
- Z is normal to the instrument attachment flange interface surface. It materializes the theoretical VLT optical axis and is directed in the VLT incoming light beam direction from point O towards MUSE via GALACSI.
- Y is directed upwards, along the gravity vector
- X is directed such as to complete the right-handed reference system.

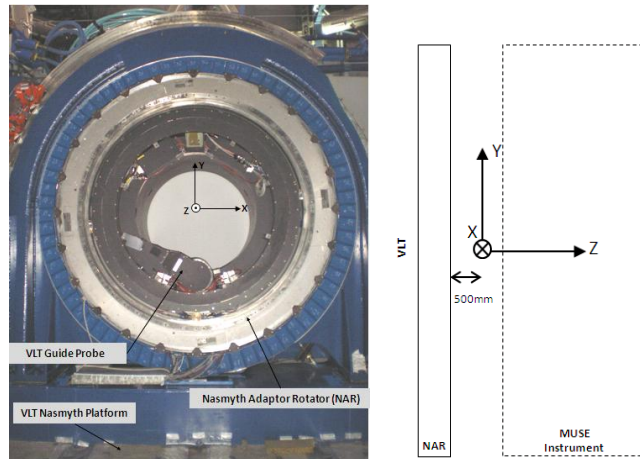

Figure 4: Coordinate system as seen from the MUSE towards the NAR and from the side of MUSE towards the NAR

4.1.3 VLT Pupil Reference

The VLT pupil is determined by the VLT secondary mirror which is designed to cover the 8m aperture for the Nasmyth unvignetted FoV.

A module has been developed by ESO to provide all the light sources necessary for the VLTI alignment Unit. For this purpose, the beacon head itself is a light weighted aluminum cylinder that inserts inside the VLT M2 central hole. That simulates the (x, y) centre of VLT pupil as VLT Pupil reference. The light comes through optic fibers coupled either with halogen lamp or laser diodes (1550, 830, 660nm). The light is “slightly” collimated and adjusted into the beam of light that covers roughly the VLT M3 surface.

4.2 MUSE Coordinate System

The MUSE Coordinate System is coincident with VLT FoV coordinate system (§ 4.1.2)

5. ALIGNMENT REQUIREMENTS

The optical interface between MUSE and UT4-VLT is driven by GALACSI requirements. The alignment requirements between MUSE and UT4-VLT are maintained at the focal plane and reproduced in Table 1.

Value indicates the nominal value of the parameter. Tolerance indicates the deviation from the nominal position due to the AIT process and the static.

Table 1: Optical specifications of the VLT/MUSE optical interface in WFM.

Parameter	Value	Tolerance
f-number	15.19	± 0.17
Focal plane position	X= 0.00 mm Y= 0.00 mm Z= 0.00 mm	X= ± 0.25 mm Y= ± 0.25 mm Z= ± 0.50 mm
Exit Pupil position	X= 0 mm Y= 0 mm	X= ± 5 mm i.e. ± 1 arcmin Y= ± 5 mm i.e. ± 1 arcmin

6. MUSE REFERENCES

Two main references are set onto MUSE instrument for all its lifetime: a FoV and Pupil References.

6.1 MUSE FoV Reference

One reference pinhole (diameter of 0.025 ± 0.002 mm) is provided by the Calibration Unit, within repositioning mechanical accuracy of ± 0.005 mm (Figure 5). This is located onto the Calibration Unit Field Mask. It is THE FoV Reference for the FoV positioning which is used for the internal and external alignment of the MUSE optical path.

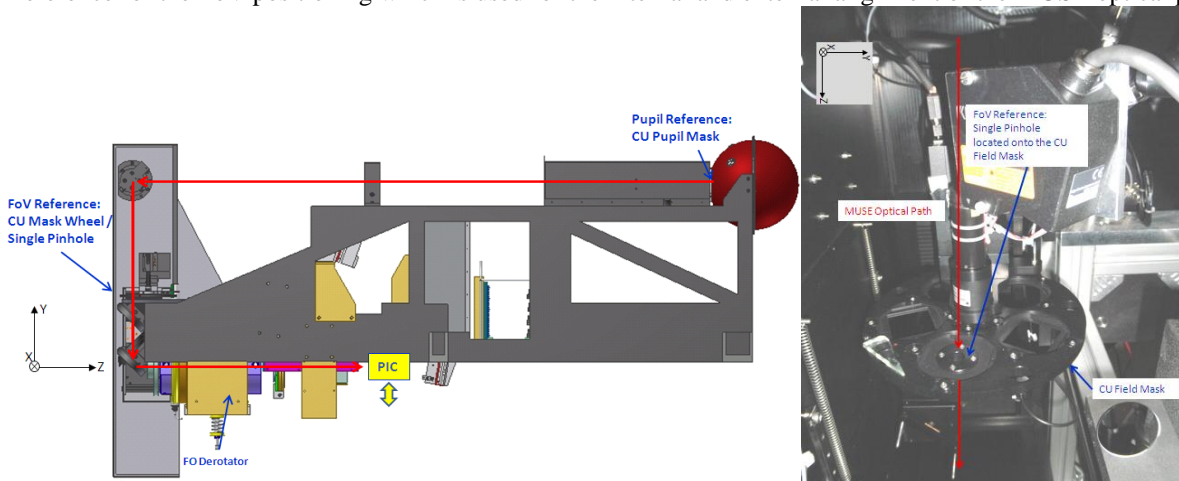

Figure 5: Left: Localisation of FoV Reference onto MUSE Calibration Unit. Right: Picture of the MUSE FoV Reference

6.2 MUSE Pupil Reference

To insure that the MUSE CU pupil and the VLT one are super-imposed, a pupil reference is set onto the MUSE Calibration Unit:

- The CU pupil mimics the VLT pupil, including central obscuration. The pupil and central obscuration diameters of CU should be reproduced within 3% of the VLT pupil diameter (80mm) - Figure 6. In MUSE, to take into account VLT pupil wobble, an oversizing of 1.3% has been set.
- A hole of 0.250mm diameter is located at the centre of MUSE CU pupil. This hole is THE Pupil Reference (Figure 6).

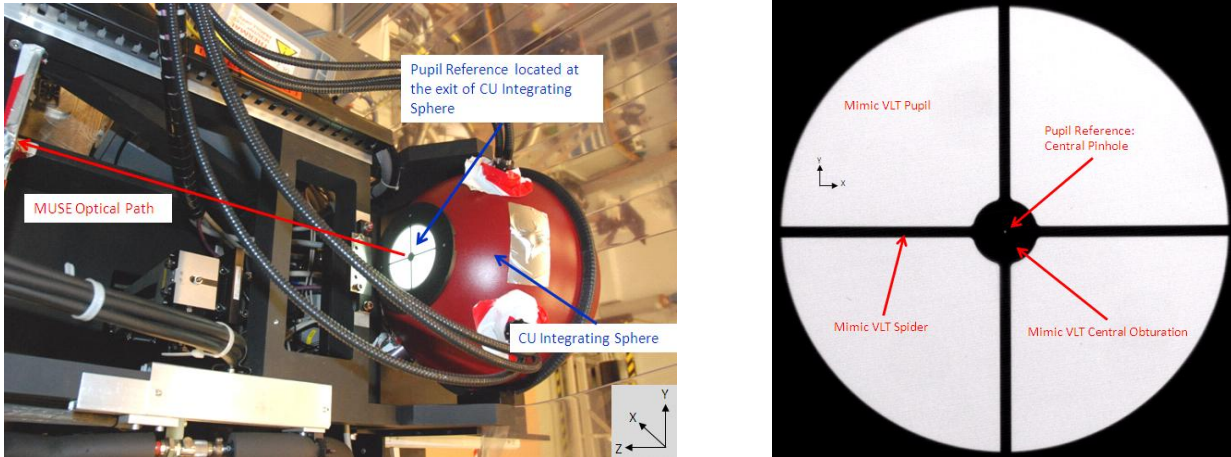

Figure 6: Left: Localisation of Pupil Reference onto MUSE Calibration Unit. Right: Optomechanical design of the MUSE Pupil Reference

7. MUSE DEGREES OF FREEDOM

The MUSE Instrument Main Structure is composed of:

- Central assembled structure i.e. central monolithic welded cube structure,
- 3-Point kinematic mounts:
 - Front double flexure support,
 - Rear flexure support left,
 - Rear flexure support right.

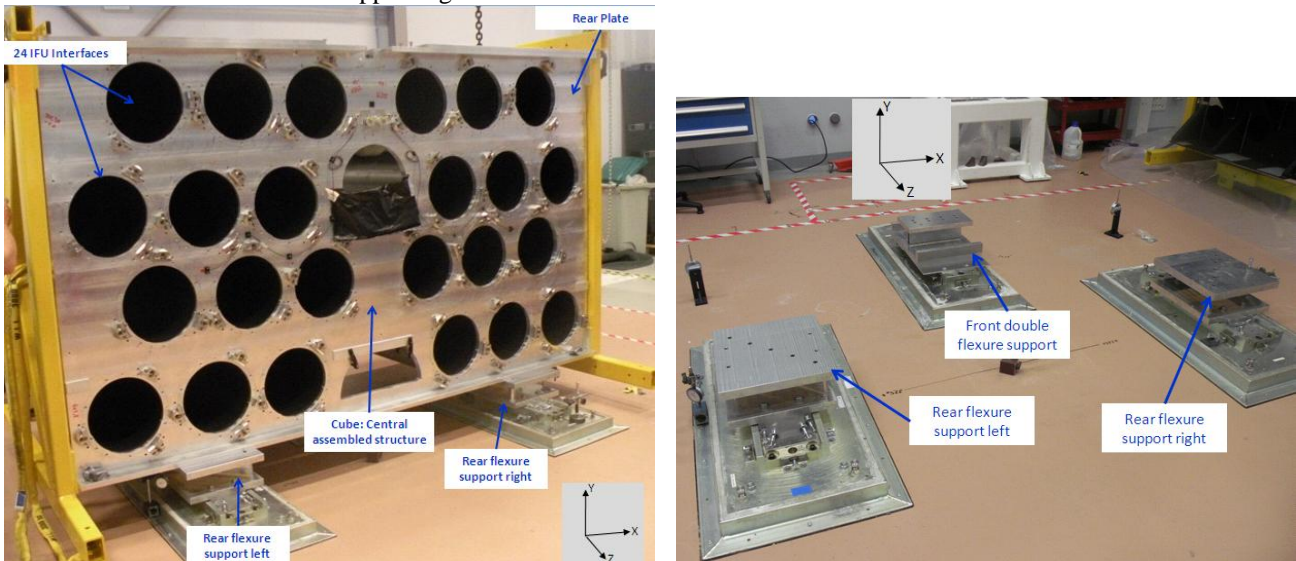

Figure 7: Left: Central assembled structure. Right: 3-Point kinematic mounts

To enable the precise alignment of the MUSE resp. UT4-VLT, six degrees of freedom in all six spatial directions are available. The fixation of the three supports between the cube structure contains slotted holes which allows precise alignment in (x, z, θ_y) - Table 2. The other three degrees of freedom (y, θ_x, θ_z) are served by shimming those supports between bottom plate and Nasmyth rails (Table 2). Note that the θ_z requirement is not required. All degrees of freedom are decoupled that save time for alignment.

Table 2: MUSE six degrees of freedom range and tolerances

Parameter	Range	Resolution	Means
Shift X	± 5 mm	± 0.1 mm	Built in slotted holes
Shift Y	± 5 mm	± 0.1 mm	Shimming set of thickness (0.1, 0.25, 0.5, 1, 2, 3 and 5mm)
Shift Z	± 5 mm	± 0.1 mm	Built in slotted holes
Tilt X	± 10 arcmin	± 0.25 arcmin	Shimming set of thickness (0.1, 0.25, 0.5, 1, 2, 3 and 5mm)
Tilt Y	± 10 arcmin	± 0.25 arcmin	Built in slotted holes
Tilt Z	± 10 arcmin	± 0.25 arcmin	Shimming set of thickness (0.1, 0.25, 0.5, 1, 2, 3 and 5mm) NB: Not applicable

8. DESCRIPTION OF TOOLS USED FOR ALIGNMENT

To perform the precise alignment of the MUSE resp. UT4-VLT, four main tools are manufactured, aligned and tested.

8.1 VLT Pupil Simulator

The VLT Pupil Simulator is the VLT Pupil Reference as defined in section 4.1.3. For MUSE alignment, the halogen lamp is used with a luminosity of 0.1%.

8.2 VLT FoV Simulator

The FoV Simulator simulates the focal plane of the VLT in positioning (x, y, z) i.e. the MUSE focal plane. It is materialized with a target attached directly onto the VLT NAR with a cross into 3 attached points; remains that NAR is the VLT reference for the focal plane (§ 4). This dedicated target is designed with concentric rings and a central hole of 2mm diameter (Figure 8). The size of the rings matches with MUSE WFM and NFM viewed through the PIC (§8.3). The diode laser coming from VLT M2 mirror (i.e. Pupil Simulator - §8.1) goes through this central hole without speckles. Moreover, the laser diode lights the central part of the FoV Simulator to perform different measurements. This target includes an external ring where the laser tracker measurement is performed. To adjust this target wrt NAR reference, it is mounted onto 3-axes lockable translation stage. The z-axis translation stage allows to check the focus positioning (Figure 8).

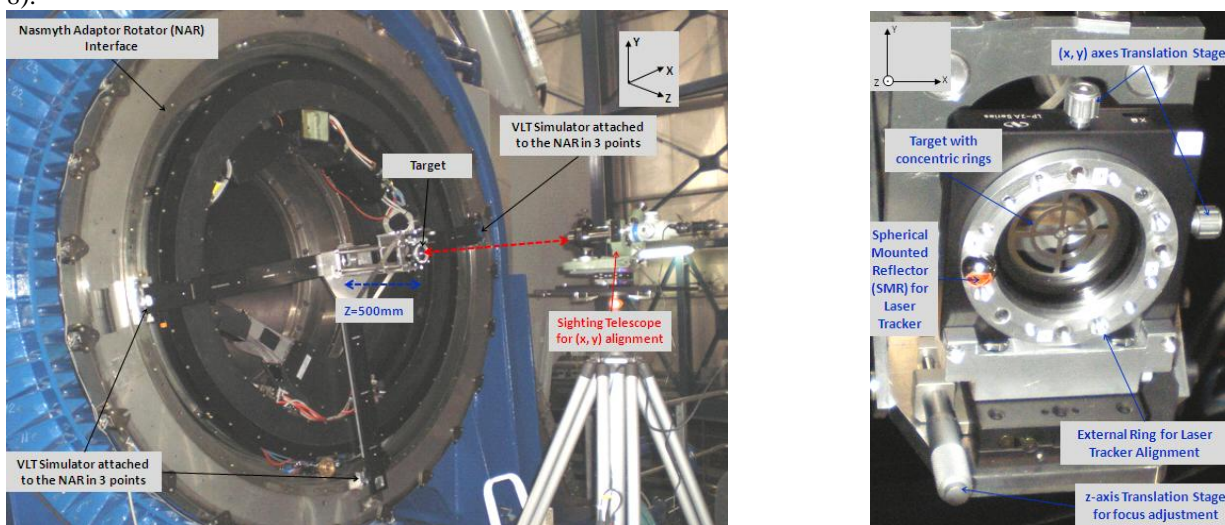

Figure 8: Left: VLT Simulator mounted onto VLT NAR. Right: Detailed view of VLT Simulator Target

The positioning of the target should be better than 0.1mm in all directions. First, the target is measured with the 3D measuring machine (accuracy of 0.01mm) wrt its external ring. This last one consists of the new reference. Second, using the laser tracker, a NAR coordinate system reference (x, y, z) is measured:

- (x, y) is the centre of the best circle defined with 12 single points measured onto NAR interface. For that, the laser tracker spherical mounted sphere is attached to the NAR reference. The NAR is rotated with 30° step to define the (x, y) circle
- z is the NAR plane.

Third, with the Spherical Mounted Reflector (SMR) positioned onto the target external ring, the positioning of the target is measured (Figure 8). Thanks the 3 degrees of freedom, the target is adjusted until its positioning is lower than 0.1mm in z-axis and 0.25mm in (x, y) axes. The (x, y) positioning is refined in installing a sighting telescope in front of the target (Figure 8, Left). The VLT NAR is rotated with step of 45° and the target positioning is recorded onto the sighting telescope. The target positioning is adjusted in (x, y) until its positioning is less than ±0.05mm.

8.3 MUSE Pupil and Image Check (PIC) Tool

The Pupil and Image Check (PIC) Tool is used both during MUSE integration (Derotator alone, Fore-Optic, Calibration Unit) and also during MUSE alignment wrt the telescope and for some periodic maintenance after an earthquake. It sights both pupil and image coming from MUSE Calibration Unit or VLT in using the focusing capacity of the objective. It is located between NFM Switching Unit and the first FO anamorphic mirror on IRLLOS mechanical interface onto a vertical translation stage. When lowered, this AIT does not block the light going to SRO and IRLLOS. Its encumbrance is compatible with the displacement of the NFM, and it is outside the scientific FoV when stored.

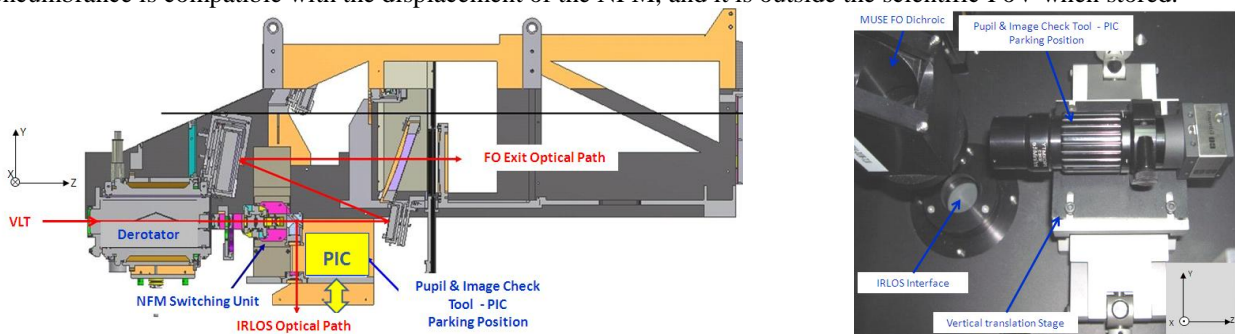

Figure 9: Left: Localisation of Pupil&Image Check. Right: Picture of PIC installed into MUSE instrument

Table 3: Characteristics of FO Pupil&Image Check

Components	Characteristics
Detector	CMOS, 1/2" size (6.83×5.45 mm), pixels size between 5 and 8 μm. Edmund Optics EO 1312 with a Micron MT9M001 monochromatic detector, USB
Objective	InfinityTM, infinimite beta+DL+extension filter holder+divergent lens / f=-150mm
Magnification	0.044 for the image (0.2arcsec on the sky~5 pixels on detector) / 0.22 for the pupil
Depth of focus	±0.4mm at VLT Focal plane level in WFM / ±0.1mm at VLT Focal plane level in NFM

8.4 MUSE Lifting Tool

The fixation of the three supports (§7) contains slotted holes which allows for a precise alignment of MUSE onto the optical axis of the VLT NAR. For that purpose, the three MUSE supports (§7) are unloaded from the total MUSE weight by three wedge systems that provides the necessary play for the supports to be precisely shifted by adjusting screws to the amount that was measured on axis displacement (x, z) and vertical rotation θy. An interface with 4 balls allows to move the MUSE 6 tons very smoothly (Figure 10).

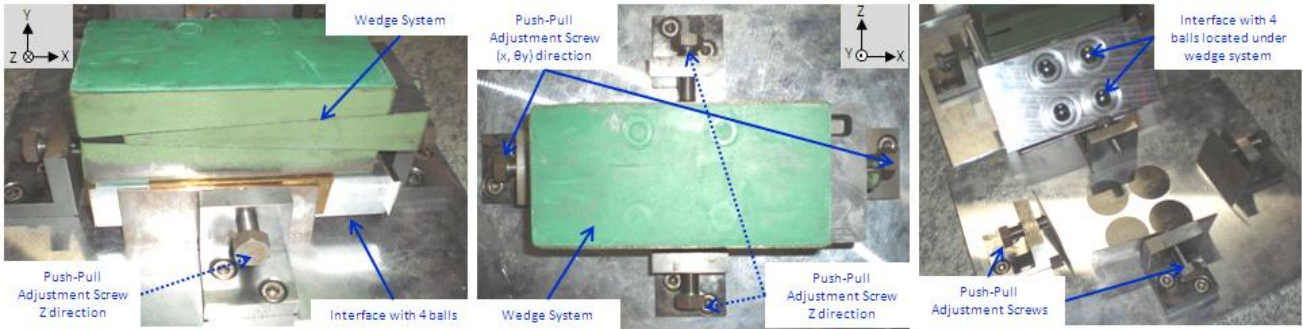

Figure 10: MUSE Lifting Tool

The three lifting tools are located under MUSE instrument onto Nasmyth rails at the opposite side of each MUSE support.

9. VLT-UT4 MEASUREMENT

All measurements performed after are recorded with the PIC (§ 8.3) when MUSE was installed except the FoV Simulator measurement vs NAR Rotation (§ 9.1) which has been done with and without MUSE.

The goal of these measurements is to find the VLT best position (NAR, azimuth and altitude positions) which matches with MUSE alignment.

9.1 FoV Simulator vs NAR Rotation

The positioning of the FoV Simulator (§ 8.2) wrt the NAR rotation is recorded 2 times: one with the sighting telescope without MUSE instrument, one with the PIC with MUSE instrument. The results are very similar. The results shows a combination between the target misalignment and the NAR run out. There is a median hysteresis of 0.03 mm. Except an area of 90° for NAR rotation which gives higher values due to FoV Simulator flexion (Figure 11, Red part), the position of VLT Simulator wrt the NAR rotation is $\pm 0.05\text{mm}$ along (x, y) axes. For this reason, MUSE alignment wrt the telescope is done at the nominal value of 183.75° for NAR rotation which corresponds to median value of measurement computed without extreme values (red part). Moreover, the measurement is stable during one week with variation as a same level as the measurement error ($\pm 0.02\text{mm}$).

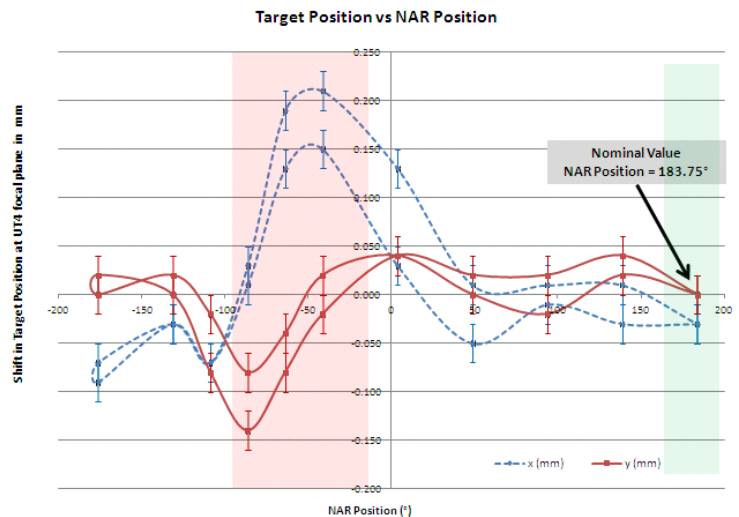

Figure 11: FoV Simulator vs NAR Rotation

9.2 FoV Simulator vs Azimuth Rotation

This measurement has been performed at 2 altitude positions: zenith and 60°. The centroid (x, y) of the target of FoV Simulator is recorded for each azimuth angle by 15° step (Figure 12). The result shows a maximum of $\pm 0.05\text{mm}$ along x-axis and $\pm 0.01\text{mm}$ along y-axis with a measurement accuracy of $\pm 0.01\text{mm}$ (Figure 12). The difference between zenith and 60° altitude positions is included into measurement accuracy i.e. less than $\pm 0.01\text{mm}$. Thanks to this measurement, MUSE alignment wrt the telescope is done at the nominal value of 0° (median value) for Azimuth position.

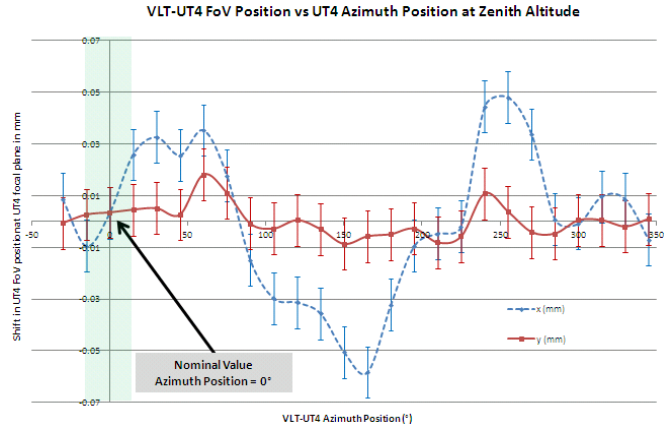

Figure 12: Left: Target of FoV Simulator seen through MUSE derotator and PIC. Right: FoV Simulator vs Azimuth Rotation at Zenith altitude

9.3 Pupil Simulator vs Azimuth Rotation

This measurement has been performed at 2 altitude positions: zenith and 60° . The centroid (x, y) of the pupil simulator is recorded for each azimuth angle by 15° step. The result shows a maximum of ± 0.07 arcmin around x-axis and ± 0.13 arcmin around y-axis with a measurement accuracy of ± 0.03 arcmin (Figure 13). The difference between zenith and 60° altitude positions is less than ± 0.06 arcmin. Thanks to this measurement, MUSE alignment wrt the telescope is done at the nominal value of 0° for Azimuth position.

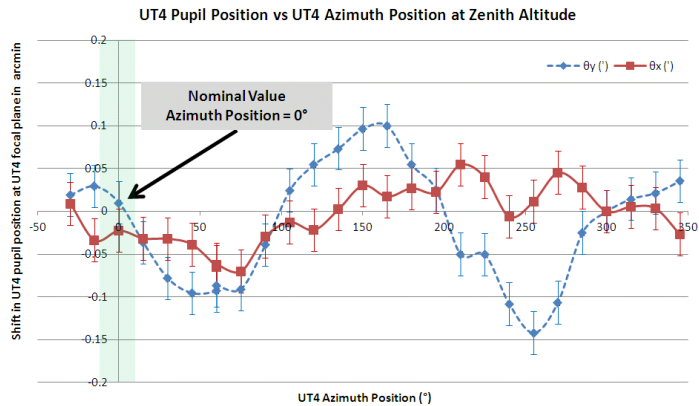
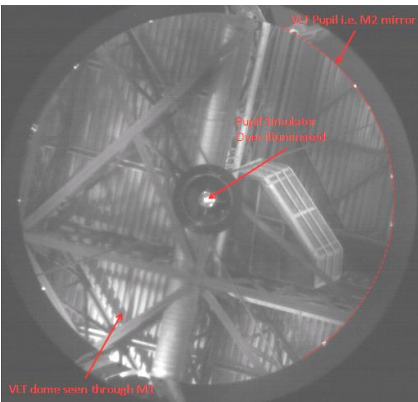

Figure 13: Left: Pupil Simulator over illuminated seen through MUSE derotator and PIC. Right: Pupil Simulator vs Azimuth Rotation at Zenith altitude

9.4 Pupil Simulator vs Altitude Rotation

This measurement has been performed at azimuth positions 60° . The centroid (x, y) of the pupil simulator is recorded for each altitude angle by 15° step. The result shows a maximum of ± 0.45 arcmin around x-axis and ± 0.15 arcmin around y-axis with a measurement accuracy of ± 0.03 arcmin (Figure 14). Thanks to this measurement, MUSE alignment wrt the telescope is done at the nominal value of 60° for altitude position.

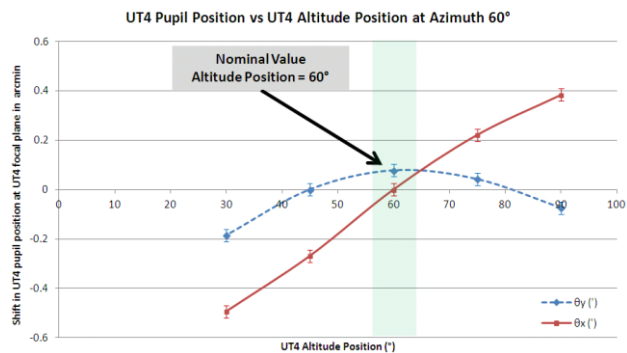

Figure 14: Pupil Simulator vs Altitude Rotation at azimuth 60°

9.5 Conclusion

Thanks of all measurements performed before, MUSE alignment wrt the VLT telescope is done at the nominal value of 183.75° for NAR position, 60° for altitude position and 0° for azimuth position.

10. ALIGNMENT PROCEDURE AND RESULTS

Before to start the alignment, the telescope is set in the position defined previously (§ 9.5).

10.1 Nasmyth Platform Preparation

Before to install MUSE onto the Nasmyth rails, MUSE coordinate system was defined with the laser tracker like described in section 8.2. With the laser tracker, the MUSE positioning was measured wrt MUSE reference and marked onto the Nasmyth rails. The platform drilling was performed (± 1 mm) in order to set MUSE into its adjustment range.

10.2 Lateral and Tip Tilt Alignment (x, y, θ_x , θ_y)

To align MUSE wrt the VLT optical axis in (x, y, θ_x , θ_y), the MUSE WFM is used through the PIC. The positions of pupil and FoV coming from MUSE and VLT are compared. The four reference exposures giving positions are recorded sequentially after each alignment, that means:

- MUSE Reference Pinhole corresponding to MUSE FoV (§ 6.1),
- FoV Simulator corresponding to VLT FoV (§ 8.2),
- Pupil Simulator corresponding to VLT Pupil (§ 8.1),
- MUSE Pupil reference corresponding to MUSE Pupil (§6.2).

For that, the focus PIC is changed in order to view either the pupil or the FoV.

10.2.1 Adjustments performed by shimming (y, θ_x)

The screws located between the three supports and Nasmyth rail are unscrewed. All push pull adjustment screws onto MUSE Lifting tool (§ 8.4) are screwed. MUSE instrument is lifting up in using the MUSE lifting tool (§ 8.4). To avoid any deformations, the MUSE elevation is performed by steps of 0.05mm onto the three lifting tools at the same time up to a final value of 0.5mm. Near each MUSE lifting tool, a micrometer is installed allowing to read the elevation value with an accuracy of 0.01mm. That allows a smooth displacement of MUSE without deformations and hysteresis during the going down. Different shims are installed under the three supports in order to fit in (y, θ_x) - Figure 15. Once the shims are installed, MUSE is unloaded. A set of reference exposures are performed. The process is repeated until the requirement in (y, θ_x) is reached (§ 5).

The final alignment shows a misalignment of -0.01 ± 0.01 mm along y-axis (Figure 15 - Middle) and -0.15 ± 0.025 arcmin around x-axis (Figure 15 - Right). That is compliant with alignment requirements. The screws located between the three supports and Nasmyth rails are screwed at nominal torque of 80Nm. The Figure 15 shows a misalignment along x-axis and around y-axis. That is fixed in next section.

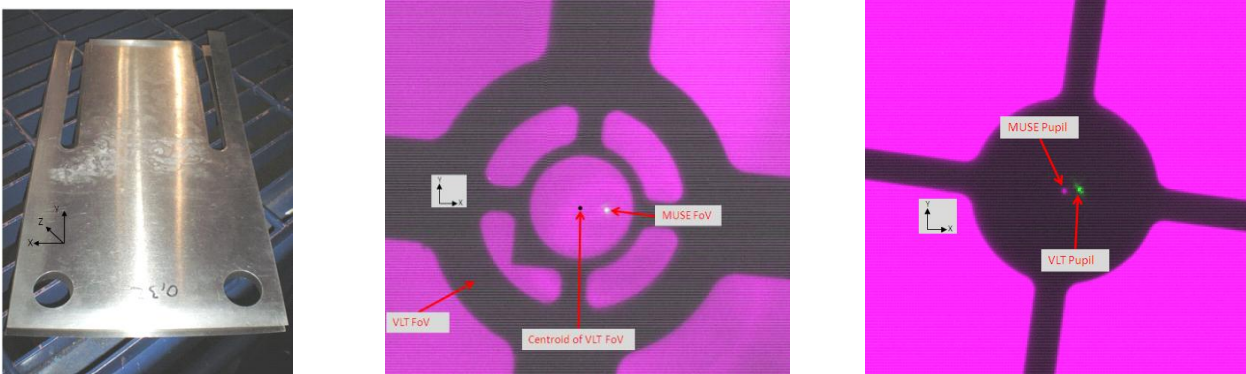

Figure 15: Left: Example of 0.3mm shim. Middle: Superimposition of FoV coming from MUSE and VLT. Right: Superimposition of pupils coming from MUSE and VLT

10.2.2 Adjustments performed by translation (x, 0y)

The screws located between the three supports and cube structure are unscrewed. All push pull adjustment screws onto MUSE Lifting tool (§ 8.4) are screwed. MUSE instrument is lifting up in using the MUSE lifting tool (§ 8.4) by steps of 0.05mm onto the three lifting tools at the same time up to a final value of 0.2mm.

When MUSE is loaded of 0.2mm, the push pull adjustment screws along x-axis are unscrewed except those onto MUSE lifting tool located at the rear. The 2 MUSE lifting tool located at the front are adjusted for rotation around y-axis. For that, the pupil simulator position is recorded with the PIC at the same time and indicates tilt correction. Once rotation around y-axis is done, the push pull adjustment screws along x-axis are unscrewed onto MUSE lifting tool located at the rear.

The 3 push pull adjustment screws are screwed at the same time along x-axis to avoid any rotation around y-axis. For that, the FoV simulator position is recorded with the PIC at the same time and indicates the x-axis motion. As the rotation around y-axis is fixed, an autocollimator is installed at the front of MUSE instrument. In using its autocollimation with a flat mirror installed into MUSE instrument, it allows to keep the correct rotation (Figure 16). If tilt appears, different quantities are applied onto the 3 push pull screws along x-axis to correct the angle. When the translation along x-axis is reached (Figure 16) without tilt around y-axis, the push pull adjustment screws along x-axis are screwed and MUSE could be unloaded.

A set of reference exposures are performed. The process is repeated until the requirement in (x, 0y) is reached. The final alignment shows a misalignment of $-0.16 \pm 0.01\text{mm}$ along x-axis (Figure 16 – Right-Top) and $-0.25 \pm 0.025\text{arcmin}$ around y-axis (Figure 16 – Right-Bottom). That is compliant with alignment requirements. The screws located between the three supports and cube structure are screwed at nominal torque of 80Nm.

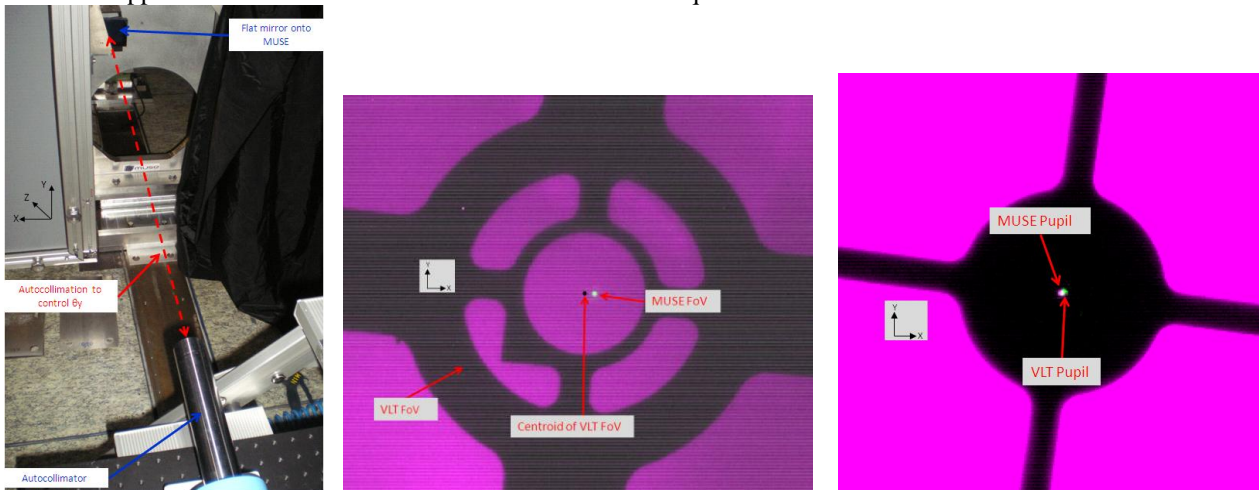

Figure 16: Left: Autocollimation wrt MUSE instrument to keep rotation around y-axis. Middle: Superimposition of FoV coming from MUSE and VLT. Right: Superimposition of pupils coming from MUSE and VLT

10.3 Focus Alignment (z-axis)

To align MUSE wrt the optical axis, the MUSE NFM is used through the PIC. Two focus curves are performed and the best focuses are compared:

- One in using the MUSE Reference Pinhole (§ 6.1),
- Another one with the FoV Simulator (§ 8.2).

For that, the PIC is installed and set in correct position and stays in the same position for the 2 focus curves. For each focus curve, the object plane is translated with steps of 0.1mm onto a range of 3mm. Note that the field in NFM is 8 times lower than MUSE WFM. The measurement accuracy is $\pm 0.1\text{mm}$.

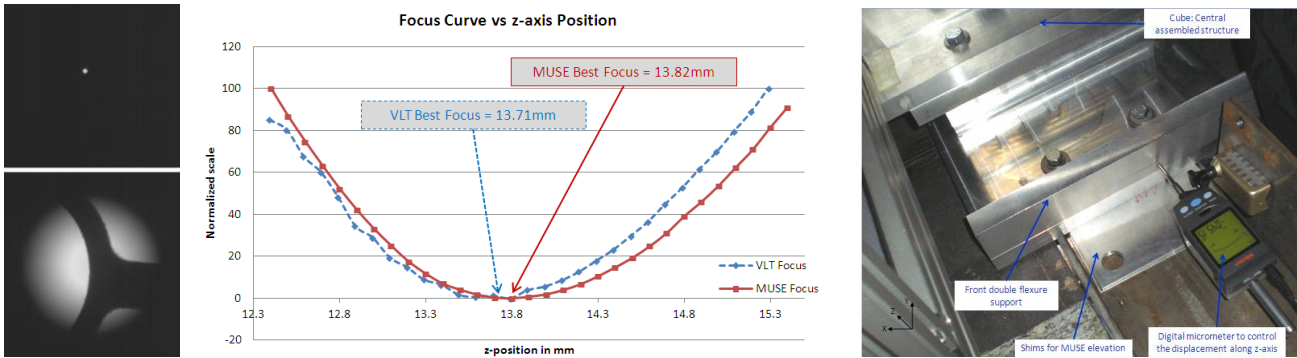

Figure 17: Left: Exposures at best focus performed with PIC in MUSE NFM: Top: Performed with MUSE Reference Pinhole. Bottom: Performed with FoV Simulator. Middle: Final focus curves after last MUSE alignment. Right: Process to align MUSE wrt telescope along z-axis

By comparing the two focus curves, MUSE is translated along z-axis up to the exact value corresponding to the difference between the two best focuses. For that, a micrometer is set onto MUSE structure along z-axis (Figure 17). The screws located between the three supports and the cube structure are unscrewed. All push pull adjustment screws onto MUSE Lifting tool (§ 8.4) are screwed. MUSE instrument is lifting up in using the MUSE lifting tool (§ 8.4). The MUSE elevation is performed by steps of 0.05mm onto the three lifting tools at the same time up to a final value of 0.2mm.

When MUSE is loaded of 0.2mm, the push pull adjustment screws along z-axis are unscrewed. It is necessary to screw the 3 push pull adjustment screws at the same time along z-axis to avoid any rotation around y-axis. For that, the pupil simulator position is recorded with the PIC at the same time and indicates any tilt. If tilt appears, different quantities are applied onto the 3 push pull screws along z-axis. When the translation along z-axis is reached (Figure 17) without tilt around y-axis (control with the autocollimator and PIC), the push pull adjustment screws along z-axis are screwed and MUSE could be unloaded. The two focus curves are performed again. The process is repeated until the requirement along z-axis is reached (§ 5) without any degradation of the lateral and tip tilt alignment (§ 10.2).

The final best focus values are: $13.71 \pm 0.1\text{mm}$ for VLT and $13.82 \pm 0.05\text{mm}$ for MUSE focus (Figure 17). The difference between the best focuses is -0.11mm which is compliant with alignment requirements. The screws located between the three supports and the cube structure are screwed at nominal torque of 80Nm.

10.4 F-number measurement

The diameter of MUSE pupil is compared to the diameter of VLT pupil i.e. M2 mirror (Figure 13). The VLT pupil is smaller than MUSE pupil of 1 arcmin in diameter. MUSE pupil takes into account oversizing of 3% of VLT pupil. That means, MUSE pupil corresponds to 229 arcmin in pupil plane. The theoretical VLT pupil measures 226 arcmin corresponding to f-number of 15.19. The measurement of VLT pupil is 228 ± 0.025 arcmin i.e. f-number of 15.06 ± 0.02 which is compliant with requirement.

10.5 Check of Pupil and FoV Wobbles

Once the alignment is performed, the VLT pupil and VLT FoV wobbles are checked onto the PIC through MUSE instrument. Due to excellent alignment of MUSE wrt VLT in tip tilt, the pupil wobble resulting of this alignment is twice less than requirement (Figure 18-Left). On the other hand, the FoV wobble is twice the requirement (Figure 18-Right) that demonstrates the shift of -0.16mm along x-axis. The wobble curves correspond to the measurement performed onto the pupil and FoV (§10.2). The FoV wobble is less important than the pupil one thanks to MUSE Slow Guiding System which allows to stabilize the FoV for the WFM.

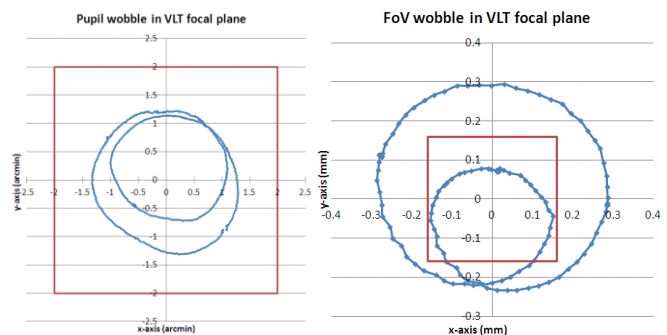

Figure 18: Left: Pupil wobble in VLT focal plane. Right: FoV wobble in VLT focal plane

10.6 Conclusion

The alignment between MUSE and VLT is compliant with requirements (§ 5).

Table 4: Measurement results of the VLT/MUSE alignment in WFM.

Parameter	Requirement	Tolerance Requirement	Measurement	Measurement Accuracy	C/NC
f-number	15.19	± 0.17	15.06	± 0.02	C
Focal plane position	X= 0.00 mm Y= 0.00 mm Z= 0.00 mm	X= ± 0.25 mm Y= ± 0.25 mm Z= ± 0.50 mm	X= -0.16 mm Y= -0.01 mm Z= -0.11 mm	X= ± 0.01 mm Y= ± 0.01 mm Z= ± 0.10 mm	C
Exit Pupil position	X= 0 mm Y= 0 mm	X= ± 5 mm Y= ± 5 mm	X= -1.25 mm Y= -0.75 mm	X= ± 0.12 mm Y= ± 0.12 mm	C

11. ALIGNMENT RESULTS ONTO THE SKY - [9]

The (x, y) alignment is checked directly onto a star which is set into the center of the field by the telescope. The Figure 19 shows the star centring wrt the VLT Simulator target. The alignment shows a misalignment of 0.05 ± 0.10 mm along x-axis and -0.14 ± 0.10 mm along y-axis (Figure 19). This result depends on the centring of the telescope and its guiding system which could be considered as included onto measurement accuracy. With this approximation, it could be considered that MUSE alignment is compliant with requirements.

The focus check is still in progress for MUSE second commissioning. The goal is to move VLT M2 mirror with a step of 5mm and perform MUSE exposures onto multiple stars (Figure 20). To minimize measurement accuracy, the VLT seeing should be better than 0.8 arcsec and stable (± 0.1 arcsec) during the focus curve. It was not the case for the first commissioning.

The pupil positioning is checked in using the 2nd diffraction order onto MUSE exposures. For that, the object “IC2501” which gives out onto blue wavelengths, is pointed with the VLT and set at different locations onto MUSE FoV. Only visual inspection onto second diffraction order are performed (Figure 21). No additional vignetting has introduced.

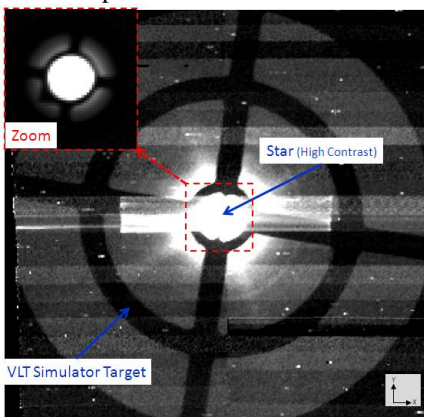

Figure 19: Star centring wrt VLT Simulator

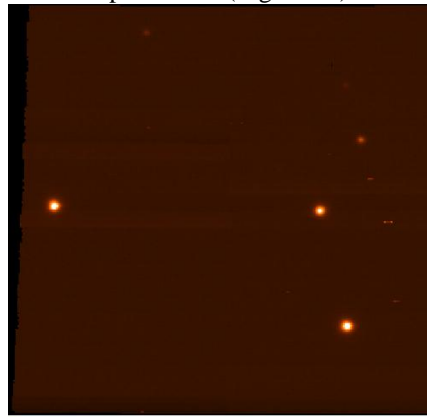

Figure 20: Multiple stars for focus check

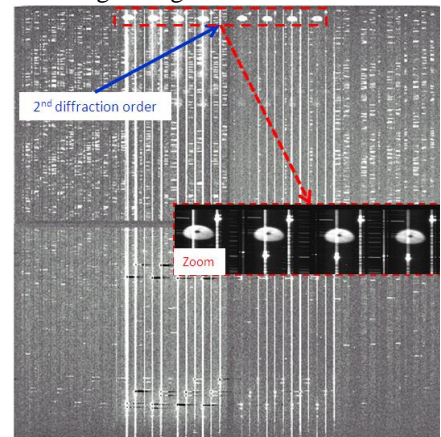

Figure 21: Vignetting Check

Table 5: Measurement results of the VLT/MUSE alignment directly onto the sky.

Parameter	Requirement	Tolerance Requirement	Measurement	Measurement Accuracy	C/NC
Focal plane position	X= 0.00 mm Y= 0.00 mm Z= 0.00 mm	X= ± 0.25 mm Y= ± 0.25 mm Z= ± 0.50 mm	X= +0.05 mm Y= -0.14 mm Z= in progress	X= ± 0.10 mm Y= ± 0.10 mm	C
Exit Pupil position	X= 0 mm Y= 0 mm i.e. No vignetting		Visual Inspection	NA	C

12. CONCLUSION

This paper describes the alignment procedure of the whole MUSE instrument with respect to the VLT. It describes how MUSE 6 tons could be move with accuracy better than 0.025mm and less than 0.25 arcmin in order to reach alignment requirement. Three days, including telescope operation constraints, were necessary to achieve this alignment. The alignment was easy to reach using decouple degrees of freedom and dedicated tools especially designed for that. The success of the MUSE alignment is demonstrated by the excellent results obtained during technical and commissioning nights onto MUSE image quality and throughput directly onto the sky.

ACKNOWLEDGMENT

We thank all the member of the MUSE team of this ESO international project at CRAL/Lyon, IRAP/Toulouse, IAG/Göttingen, AIP/Potsdam, Leiden Obs, ETH/Zürich and ESO/Garching for their invaluable contribution. This work was strongly supported by MUSE management and technical teams. We thank especially ESO, CNRS/INSU and University Claude-Bernard Lyon I for their strong support to the MUSE project.

REFERENCES

- [1] Bacon R. et al., "Highlights from the Multi unit Spectroscopic Explorer (MUSE) a 2nd generation VLT instrument for the VLT," Proc SPIE 9147, 506 (2014)
- [2] La Penna P. et al., "GALACSI integration and functional tests," Proc. SPIE 9148, 101 (2014)
- [3] Kelz A. et al., "Development and performance of the MUSE calibration unit," Proc. SPIE 8446, 222 (2012)
- [4] Lizon J.L. et al., "Detector vacuum and cryogenic system for MUSE," Proc SPIE 8446, 217 (2012)
- [5] Caillier P. et al, "MUSE instrument performance through time from design to the sky," Proc SPIE 9147, 224 (2014)
- [6] Nicklas H. et al., "Performance of the main instrument structure and the optical relay system of MUSE," Proc SPIE 8446, 223 (2012)
- [7] Parès L. et al., "Fore-optics of the MUSE instrument," Proc. SPIE 8446, 220 (2012)
- [8] Reiss R. et al., "The MUSE instrument detector system," Proc. SPIE 8446, 98 (2012)
- [9] Richard J. et al., "VLT/MUSE global performances as measured during commissioning," Proc. SPIE 9147, 113 (2014)
- [10] Laurent F. et al., "MUSE field splitter unit: fan-shaped separator for 24 integral field units," Proc. SPIE 9151, 64 (2014)
- [11] Caillier P. et al., "MUSE installation on the VLT," Proc. SPIE 9147, 362 (2014)
- [12] Laurent F. et al., "MUSE optical alignment procedure," Proc SPIE 8446, 226 (2012)