



**HAL**  
open science

## Contribution to Online System-level Prognostics based on Adaptive Degradation Models

Ferhat Tamssaouet, Khanh Nguyen, Kamal Medjaher, Marcos Orchard

► **To cite this version:**

Ferhat Tamssaouet, Khanh Nguyen, Kamal Medjaher, Marcos Orchard. Contribution to Online System-level Prognostics based on Adaptive Degradation Models. PHM Society European Conference, PHM Society, Jul 2020, Virtuel - Online, France. 10.36001/phme.2020.v5i1.1213 . hal-04775722

**HAL Id: hal-04775722**

**<https://hal.science/hal-04775722v1>**

Submitted on 10 Nov 2024

**HAL** is a multi-disciplinary open access archive for the deposit and dissemination of scientific research documents, whether they are published or not. The documents may come from teaching and research institutions in France or abroad, or from public or private research centers.

L'archive ouverte pluridisciplinaire **HAL**, est destinée au dépôt et à la diffusion de documents scientifiques de niveau recherche, publiés ou non, émanant des établissements d'enseignement et de recherche français ou étrangers, des laboratoires publics ou privés.

# A Contribution to Online System-level Prognostics based on Adaptive Degradation Models

Ferhat Tamssaouet<sup>1</sup>, Khanh T.P. Nguyen<sup>2</sup>, Kamal Medjaher<sup>3</sup> and Marcos Orchard<sup>4</sup>,

<sup>1,2,3</sup> *Laboratoire Génie de Production, INP-ENIT, Université de Toulouse, Tarbes, 65000, France*

*ferhat.tamssaouet@enit.fr*

*thi-phuong-khanh.nguyen@enit.fr*

*kamal.medjaher@enit.fr*

<sup>4</sup> *University of Chile, Santiago, Metropolitan Region, 8370451, Chile*

*morchard@u.uchile.cl*

## ABSTRACT

Considering traditional model-based prognostics approaches, a previously defined model is required to estimate the system's health state and then propagate it to predict the system remaining useful life (SRUL). Following a Bayesian framework, the result of this prior estimation is updated by in-field measurements without changing the model parameters. Nevertheless, in the case of prognostics at system-level, solely updating prior health state, based on the pre-determined model, is no longer sufficient because numerous mutual interactions between components cause multiple uncertainties in system degradation modeling, and then can lead to inaccurate SRUL prediction. Therefore, this paper proposes a new methodology for online joint uncertainty quantification and model estimation based on particle filtering (PF) and gradient descent (GD). In detail, the inoperability input-output model (IIM) is used to characterize system degradations considering interactions between components and effects of the mission profile; and then the inoperability of system components is estimated in a probabilistic manner using PF. In the case of consecutive discrepancy between the prior and posterior estimates of the system health state, GD is used to correct and to adapt the IIM parameters. To illustrate the effectiveness of the proposed methodology and its suitability for an online implementation, the Tennessee Eastman Process is investigated as a case study.

## 1. INTRODUCTION

Until now, research in the field of failure prognostics, in the literature, is conducted generally at component-level (Daigle, Bregon, & Roychoudhury, 2012; Atamuradov, Medjaher, Dersin, Lamoureux, & Zerhouni, 2017). However, complex engi-

neering systems are composed of multiple individual components operating interactively. Thus, when one or more components fail, the performances of the whole system are adversely affected. Therefore, the development of system-level prognostics approaches is also essential. However, in that perspective, several challenges are faced. Among them, three main challenges will be investigated and solved in this paper.

The first challenge concerns the development of the model that allows the various factors influencing the evolution of system degradation to be taken into account, including the components' mutual interactions and the effects of the mission profile. However, most systems are composed of heterogeneous elements with different operating mechanisms, which makes modeling them difficult (Liu & Zio, 2016).

The second challenge is related to uncertainty quantification. Indeed, the transition from component-level to system-level prognostics leads to an increase in the number of uncertainty sources, which causes more issues when predicting the SRUL (Das, Elburn, Pecht, & Sood, 2019).

The third challenge concerns the online implementation of the prognostics algorithms. This is due to two principal reasons: 1) the unavailability of prior and extended knowledge about the systems under study because of the impossibility to perform run-to-failure experiments for equipment availability, cost, or safety reasons (Acuña & Orchard, 2017), and 2) the implementation of these algorithms is computing resources demanding, given the modern system complexity.

In this paper, a methodology for online failure prognostics at the system-level is presented. The inoperability input-output model (IIM), which considers interdependencies between components, mission profile, and inner component degradations, is used as a modeling framework. This methodology requires minimal input information on system degradation since the

Ferhat Tamssaouet et al. This is an open-access article distributed under the terms of the Creative Commons Attribution 3.0 United States License, which permits unrestricted use, distribution, and reproduction in any medium, provided the original author and source are credited.

parameters of the IIM model can be estimated and corrected online using our developed algorithm based on gradient descent. The resulting IIM model is then exploited by a particle filter to estimate the health state of the system, by taking into account the process uncertainty and the monitoring data received from the sensors. Once a fault is detected, and based on the functional architecture of the system, its estimated health state is propagated into the future to determine its system remaining useful life (SRUL). The results of this methodology are evaluated, at each execution of the dedicated algorithm, to find a balance between prediction accuracy and computation time.

The remainder of the paper is organized as follows. Firstly, Section 2 presents the inoperability input-output model. Section 3 focuses on the description of the elements composing the proposed methodology, and its online implementation is detailed in Section 4. The effectiveness and applicability of the proposed methodology are discussed in Section 5, through a real industrial case study, which is the Tennessee Eastman Process. Finally, Section 6 concludes the paper and gives some future works.

## 2. SYSTEM DEGRADATION MODELING FRAMEWORK

Confronted with the nonexistence of a modeling framework to represent the system degradation in a comprehensive way, the authors have proposed in previous works the inoperability input-output model (IIM) (Tamssaouet, Nguyen, & Medjaher, 2019). This model considers heterogeneous systems by introducing the concept of inoperability, which expresses the distance between the state of health of the current system and its failure threshold. The fact that the IIM can take into account mutual interactions between numerous elements offers a promising perspective when applying it in the PHM domain. The formulation of the IIM, in the context of prognostics, is as follows (Tamssaouet et al., 2019):

$$q(t) = K(t) \cdot [A \cdot q(t-1) + c(t)] \quad (1)$$

where:

- $q(t)$  is a vector representing the overall inoperability of the system components at time  $t$ . Each component of this vector is a value between 0 and 1, where  $q_i(t) = 0$  corresponds to a healthy component and  $q_i(t) = 1$  to a faulty component.
- $A$  is a matrix representing the interdependencies between the system components. Each element  $a_{ij}$  of the matrix corresponds to the influence of the inoperability of a component  $j$  on the inoperability of a component  $i$ . The bigger  $a_{ij}$  is, the greater is the influence of  $j$  on  $i$ .
- $c(t)$  is a vector representing the system components' internal inoperabilities at time  $t$ , i.e., the degradation of the components due to wear, corrosion, or any other failure mechanism. The parameter  $c_i(t)$  can be obtained by nor-

malizing the health indicator of the component  $i$  to its failure threshold (see (Tamssaouet et al., 2019) for further details about health indicator normalization).

- $K(t)$  is a diagonal matrix representing the factors influencing the inoperabilities of the components at time  $t$  in relationship with the system mission profile. Each element  $k_i(t)$  is specific to only one component  $i$ .

The proposed IIM can address a wide range of interdependencies between the system components and several situations related to systems operation (Tamssaouet, Nguyen, Medjaher, & Orchard, 2020).

## 3. METHODOLOGY FOR JOINT PARAMETER ESTIMATION AND SRUL PREDICTION

The methodology proposed in this paper for the online determination of the SRUL involves three steps. The first one consists in the determination of the system degradation model parameters (i.e., IIM). Once this model is determined, the second step concerns its utilization to estimate the system health state and predict its future evolution, while characterizing the related uncertainties. This step is carried out online by combining model predictions and monitoring data. The third step is the calculation of the SRUL based on the system configuration. These steps will be detailed in this section, while its online application will be presented in section 4.

### 3.1. Estimation of system degradation model parameters

In a model-based prognostics approach, data are mainly used to identify and update the parameters of a pre-determined degradation model. In the literature, there exist numerous methods that can be applied for parameter estimation. Among them, the gradient descent GD method (Snyman & Wilke, 2018) is proposed for this work. Indeed, this method is adapted for model parameter estimation in system-level prognostics because 1) It can be applied for linear/non-linear models, 2) it can effectively handle a great number of parameters at the same time, which is the case in system-level prognostics, 3) it is an adaptable method thanks to its many extensions (Ruder, 2016), and 4) compared to Newton's method or inversion of the Hessian using conjugate gradient techniques, it is not computationally intensive, making it suitable for an online application.

In this framework, the IIM parameters are identified to minimize the mean squared error (MSE) between the inoperability estimated by the model,  $\hat{q}_i$ , and the in-field measured inoperability,  $q_i$ :

$$\mathcal{L}(\hat{q}_i, q_i) = \frac{1}{N} (\hat{q}_i - q_i)^2 \quad (2)$$

Algorithm 1 describes how to determine all the IIM parameters, including the internal inoperability evolution of every component  $c_i(t, \theta_i)$ , the interdependencies matrix  $A$  and the

**Algorithm 1** General algorithm for estimating the IIM parameters related to a component  $i$

1. Set initial values of IIM parameters ( $a_{ij}^0, k_i^0, \theta_i^0$ )
2. at the  $(h + 1)$ -th iteration step ( $h \in N^+$ ), **while** stopping criterion not satisfied

- Evaluate

$$\hat{q}_i(t) = k_i^h \left[ \sum_{j=1, j \neq i}^M a_{ij}^h q_j(t-1) + c_i(t, \theta_i^h) \right]$$

- Calculate the gradients regarding each parameter:  $\frac{\partial \mathcal{L}}{\partial k_i^h}, \frac{\partial \mathcal{L}}{\partial a_{ij}^h}, \frac{\partial \mathcal{L}}{\partial \theta_i^h}$
- Update the IIM parameters:

$$k_i^{h+1} = k_i^h - \gamma \frac{\partial \mathcal{L}}{\partial k_i^h}$$

$$a_{ij}^{h+1} = a_{ij}^h - \gamma \frac{\partial \mathcal{L}}{\partial a_{ij}^h}$$

$$\theta_i^{h+1} = \theta_i^h - \gamma \frac{\partial \mathcal{L}}{\partial \theta_i^h}$$

3. **end while**

matrix of the external influencing factors encompassed in matrix  $K$ . Without loss of generality, let's consider that  $c_i(t, \theta_i)$  is a differentiable multi-variable function of parameters  $\theta_i$  that need to be estimated. In Algorithm 1, the stopping criterion can be set as a fixed number of iterations, a given value of MSE (the less is the MSE, the more is the accuracy of the model) or when an optimum is reached (a null gradient).

Depending on the prior knowledge available about the system degradation mechanisms, Algorithm 1 can be adapted easily in order to estimate only the unknown parameters.

Once the model has been formulated and its parameters determined, it will be used to estimate and predict the system health state, as explained in the next subsection.

### 3.2. System health state estimation and prediction

To estimate the health of the system and its related uncertainty, the degradation model (i.e., IIM) and monitoring data are used in the Bayesian filtering (BF) approach. Since real systems are generally non-linear and have non-Gaussian noise, a widely-used method to obtain a sub-optimal solution for the BF problem is the particle filtering (PF) (M. Orchard, 2006). In addition to the current health state estimation, this method is also used to predict the future health state of the system, as described below.

#### 3.2.1. Inoperability uncertainty estimation

In order to estimate the inoperability posterior density of the  $M$  system components at each time instant  $k$  given the observations  $y_k$ , the particle filtering (PF) is used. However, con-

trary to its traditional utilization, in this paper, a particle is considered as a vector representing the state of health (inoperability) of the system components. Thus, the weight associated with a particle represents the approximation of the inoperability probabilities of all the  $M$  components at the same time. That means that each particle's weight represents the probability that the system components have particular values of inoperability contained in the particle's vector. The process of estimating the inoperability state of a system at a time  $k$  is explained in the following.

Firstly, using the IIM presented in Section 2, the prior probability density distributions PDFs of the system components inoperabilities  $p(q_k|q_{k-1})$  at time  $k$  are predicted based on the ones at the previous time  $k - 1$ :

$$p(q_k|q_{k-1}) \sim IIM(q_{k-1}) \quad (3)$$

Next, given new observations  $y_k$  at time  $k$  for a component  $i$ ,  $i \in \{0, 1, \dots, M\}$ , the system posterior PDFs inoperabilities are updated by the particle filtering. In detail, considering a set of  $N$  particles  $\{q^{(l)}\}_{l=1, \dots, N}$ , their associated normalized weights  $\{w^{(l)}\}_{l=1, \dots, N}$  are evaluated by the likelihood functions  $p(y_k|q_k)$  using the importance distribution functions  $\pi(q_k|q_{k-1}, y_{1:k})$ :

$$w_k^{(l)} \propto w_{k-1}^{(l)} \prod_i \frac{p(y_k|q_k^{(l)})p(q_k^{(l)}|q_{k-1}^{(l)})}{\pi(q_k|q_{k-1}, y_{1:k})} \quad (4)$$

Finally, to overcome the degeneracy problem, a resampling process is applied in each time step to replace particles having low importance weights with particles that have higher importance weights.

The posterior PDFs of the system inoperability at time  $k$  can be approximated before the resampling step by:

$$p(q_k|y_{0:k}) \approx \sum_{l=1}^N w_k^{(l)} \delta_{q_k}^{(l)}(q_k) \quad (5)$$

where  $\delta(\cdot)$  denotes the Dirac delta function.

The estimation procedure is repeated at every instant  $k$ ,  $k \in \{1, 2, \dots, k_p\}$ , where  $k_p$  is the starting time of the prediction step presented in the next subsection.

### 3.3. Inoperability uncertainty prediction

Prognostics is a problem that goes beyond the scope of filtering problem since it involves future time horizons in which no measurements are available. Thus, the particle filtering, which is more suitable for estimation problems, needs to be adapted to use it for prediction.

In this work, to reduce the computation requirement, we sug-

gest to follow the procedure proposed in (Doucet, Godsill, & Andrieu, 2000) and which is based on the assumption that the particle weights are constant from time  $k_p$  to time  $k$ . According to this procedure, the predicted PDF of the inoperability of the system's components at time  $k$  (i.e.,  $p(q_k|y_{1:k_p})$ ) can be obtained by applying recursively (3) to  $q_{k_p}^{(l)}$ .

Once the prediction of the future system inoperability is made, it will be used to determine the system remaining useful life (SRUL), as explained in the next subsection.

### 3.4. SRUL determination

The SRUL provides information related to the time when the whole system fails (i.e., when the combined failures of individual components lead to system failure) (Rodrigues, 2018). However, the consequence of the degradation of one or more components depends on the considered architecture (e.g., parallel or series). Therefore, the SRUL must be calculated according to the system configuration.

Assuming that the system is healthy at time  $k_p - th$ , moment when the prediction algorithm is launched, the SRUL can be computed as follows:

$$SRUL = \tau_F - k_p \quad (6)$$

with  $\tau_F$  is the system time-of-failure ToF with:

$$\tau_F = \inf(k \in N : \text{system failure at } k) \quad (7)$$

To determine the ToF, let's denote a healthy system (with no occurrence of catastrophic failure) and a faulty system (with the occurrence of catastrophic failure) at  $k - th$  by  $H_k$  and  $F_k$ , respectively. Let's also consider  $H_{k_p:k} = (H_{k_p}, H_{k_p} + 1, \dots, H_k)$  as the sample space that determines all possible sequences where a system has not catastrophically failed until the time  $k$ . Then, according to the definition of the conditional probability, the failure probability without considering maintenance (i.e., the system can only fail once) at  $k - th$  is given by:

$$P(F_k) = P(F_k|H_{k_p:k-1})p(H_{k_p:k-1}); \forall k > k_p \quad (8)$$

where  $P(F_k|H_{k_p:k-1})$  is given by:

$$P(F_k|H_{k_p:k-1}) = \int_{R^{n_q}} p(\text{failure}|q_k)p(q_k|y_{1:k_p})d_{q_k} \quad (9)$$

The second term of (8),  $p(H_{k_p:k-1})$ , stands for the probability that one component is healthy from  $k_p - th$  until time  $(k - 1) - th$ , which can be expressed as:

$$p(H_{k_p:k-1}) = \prod_{h=k_p+1}^{k-1} p(H_h|H_{k_p:h-1}) \quad (10)$$

As  $F_k$  and  $H_k$  are exclusive events, the failure event can be modeled as Bernoulli stochastic process. It follows that:

$$p(H_{k_p:k-1}) = \prod_{h=k_p+1}^{k-1} (1 - p(F_h|H_{k_p:h-1})) \quad (11)$$

The expressions presented in (8) and (11) are valid, whether for prognostics of a single component or complex systems. However, when considering a multi-components system, the way of characterizing  $p(F_k|H_{k_p:k-1})$  will change according to the system configuration. For example, in a series configuration of  $M$  components, the probability that a system will fail at time  $k$ , conditional that it is healthy at  $k - 1$ , is a finite union of the components failure events. As only one component failure can appear at an instantaneous moment, the components failure events can be considered as incompatible. Then, the system failure probability can be written as:

$$p(F_k|H_{k_p:k-1}) = \sum_{i=1}^M p(F_{i_k}|H_{k_p:k-1}) \quad (12)$$

where  $p(F_{i_k}|H_{k_p:k-1})$  is the probability that component  $i$  will fail at time  $k$ , conditional that the system is healthy at  $k - 1$ .

## 4. ONLINE IMPLEMENTATION OF THE PROPOSED JOINT PARAMETER ESTIMATION AND SRUL PREDICTION METHODOLOGY

The main problem with the online implementation of a prognostics algorithm is its computing time (Pecht, 2009). The online implementation of the methodology proposed in this paper allows to reduce the computation time but also to address two other problems, which are:

- The problem of online prediction of RUL/SRUL has been widely studied through filtering or machine learning methods (M. E. Orchard & Vachtsevanos, 2009). However, these methods suggest that the system degradation models are already estimated (for model-based methods) or trained (for data-driven methods) and can be used by merely updating them. Nevertheless, in practice, this information is not available. In this case, the parametric estimation of the degradation model must be done online at the same time as the system health state estimation and prediction.
- In a Bayesian approach of prognostics, the estimates given by the model are corrected by actual measures about the system health state without changing the parameters of the model. However, in the case of system-level prognostics, uncertainties associated with modeling can be very high. Therefore, the degradation model needs to be adaptive with regard to the monitored system.

Figure 1 presents an overview of the proposed methodology

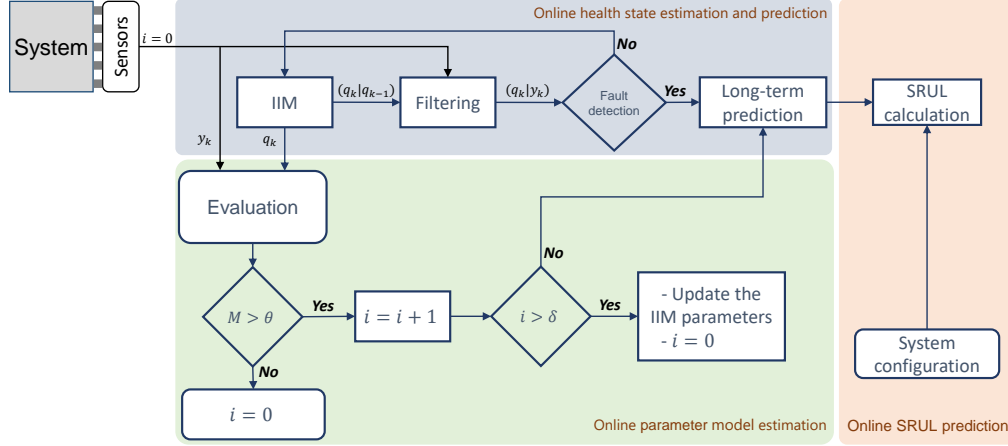

Figure 1. Methodology for online joint parameter estimation and SRUL prediction.

for an online combined estimation of the IIM parameters and SRUL probabilistic prediction. Requiring only the trends of the component-level degradation (i.e.  $c(t)$ ), it allows performing three principal tasks: 1) online estimation of the system health state, 2) online update of the IIM parameters and 3) online probabilistic SRUL prediction.

In detail, the IIM, whose initial parameters were estimated offline by performing run-to-failure experiments or randomly-generated, is used at time  $k$  to predict (short-term prediction) the health state at time  $k + 1$  (prior estimation). At the time  $k + 1$ , when new pre-processed degradation data acquired by sensors are available, the prior estimation is filtered to obtain the posterior one using particle filtering. If an anomaly has been detected or a threshold value for the inoperability of a component has been exceeded, the posterior PDF is propagated (long-term prediction) to calculate the SRUL; otherwise, we continue filtering. After every short-term prediction, the prior health state estimation is evaluated with respect to the actual data. If there is a discrepancy, the long-term prediction is updated along with the estimated SRUL (if an anomaly is already detected). In this case, the parameter  $i$ , which represents the number of consecutive discrepancies observed, is incremented; otherwise, it is reinitialized. If several discrepancies appear consecutively ( $i$  exceeding a number  $\delta$  set by the user), the gradient descent is used to update the IIM parameters.

As mentioned above, the proposed methodology requires an effective way to assess whether the difference between the measurement acquired by sensors and the predicted health state obtained by IIM is significant. In this work, the authors propose a method based on the evaluation of the uncertainty characterization. In that aim, the number of particles that fall within the accuracy range of the sensor values is determined,

i.e.:

$$M = \sum_{i \in \{n=1 \dots N | q_k \notin [y_k - \alpha \delta_{data}, y_k + \alpha \delta_{data}]\}} w_k^{(i)} \quad (13)$$

with the number of particles that should be included in the confidence interval is fixed by the user, and  $\alpha$  is a parameter to delimits this confidence interval. Since most modern sensors are calibrated to have a Gaussian uncertainty, it is possible to use the 68–95–99.7 rule, which represents the percentage of values that lie within a band around the mean with a width of two, four, and six standard deviations, respectively. Thus, depending on the confidence that we have on the sensor measures, one percentage value can be chosen.

In summary, the proposed methodology allows online system state estimation and SRUL prediction, with accurate and reliable results. Indeed, the update of the IIM parameters and the long-term prediction of the component inoperability evolution is not done systematically, but only when a discrepancy is observed. This procedure prevents unnecessary computational time. Also, the parameter estimation process can

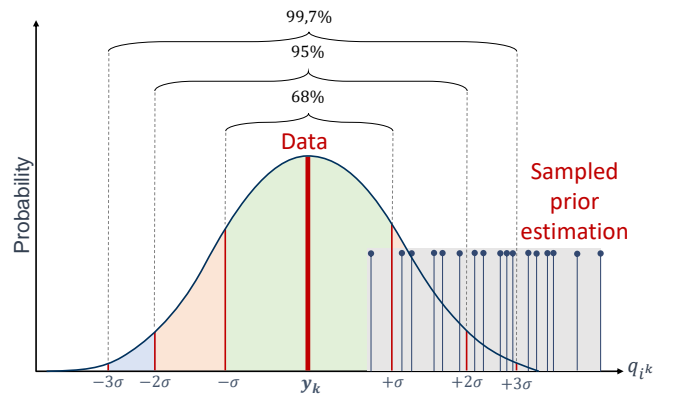

Figure 2. Evaluation of the filtering performance.

be stopped when its execution time is equal to the sampling time of measurements, or the loss function is close to zero. Note that the obtained values of the IIM parameters will be used as the initial values in the next iteration when a new measurement is acquired. Then, even if the optimum is not reached at a certain iteration of the algorithm, it is approached in the direction of that optimum. This 1) guarantees a precision of the final results in terms of parameter estimation and thus improves the accuracy of health state estimation and prediction 2) reduces the complexity of the proposed method, as the number of iterations it takes for the gradient descent algorithm to meet its shutdown criterion decreases. Finally, the algorithm complexity decreases rapidly if parameters of the IIM are known exactly a priori to reach a quadratic complexity in case only the interactions between the components are unknown.

## 5. APPLICATION AND RESULTS

In this section, the proposed methodology is applied to solve the failure prognostics issue of the Tennessee Eastman Process (TEP).

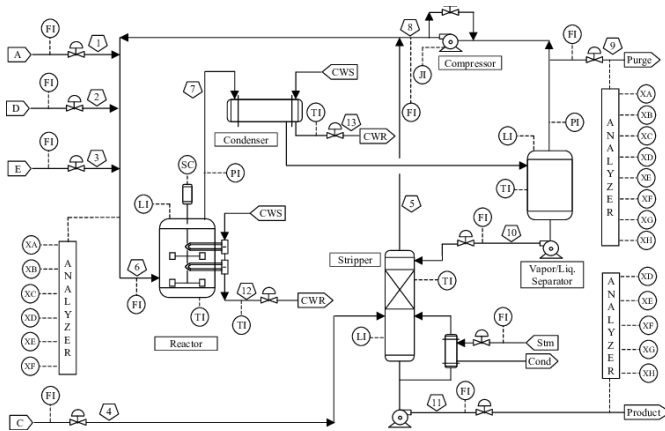

Figure 3. P&ID of Tennessee Eastman Process (Downs & Vogel, 1993).

### 5.1. System presentation

The Tennessee Eastman Process (Downs & Vogel, 1993) is used in the literature as a realistic benchmark for process control optimization and fault diagnostics. The TEP involves five major units (working in open-loop), including a two-phase reactor, a partial condenser, a separator, a stripper, and a compressor, as shown in the schematic flow diagram and instrumentation (P&ID) of the Fig.3. The aim of this process is the synthesis of two liquid products from gaseous reactants. The process is monitored by 53 variables. In order to observe the system response, 28 faults can be injected (Bathelt, Ricker, & Jelali, 2015), which can be related to set-point changes, drifts, or random variation of variables.

As the TEP was not intended, initially, for prognostics purposes, its fundamental paradigms are changed to liken system degradation, as detailed in the next subsection.

### 5.2. Problem formulation

In this case study, the authors consider failure as the interruption of the operational continuity resulting from the violation of the variables shutdown limits. Therefore, only components with shutdown constraints are considered, i.e., the reactor, the stripper, and the separator. Each of these components is monitored by a single parameter: pressure for the reactor, and liquid level for the stripper and the separator. Table 1 lists the specific operational constraints related to the system's parameter that the control system should respect.

Process variables	Operating limits		Shutdown limits	
	Low	High	Low	High
Reactor pressure (kPa)	none	2895	none	3000
Separator level (m)	3.3	9.0	1.0	12
Stripper level (m)	3.5	6.6	1.0	8.0

Table 1. TEP operating constraints (Downs & Vogel, 1993).

Two disturbances predefined in (Bathelt et al., 2015) were injected. These disturbances, occurring in the reactor and the stripper respectively, are represented as a deviation in the reactor cooling water flow and a deviation in the heat transfer of the heat exchanger of the stripper. Then, the own degradation process of the components (i.e.  $c_1(t)$  and  $c_2(t)$ ), are assumed to follow equations 14 and 15, respectively.

$$c_1(t) = \alpha \cdot c_1(t-1) + \beta \quad (14)$$

$$c_2(t) = \epsilon \cdot c_2(t-1) \quad (15)$$

with  $\alpha$ ,  $\beta$ , and  $\epsilon$  are the parameters of the two models to be estimated as well as the components of the matrix  $A$  from the monitoring data. Regarding the matrix of influencing factors  $K$ , its diagonal elements  $k_i$  are equal to 1 because the data are acquired in the default production mode.

As the TEP is a continuous production process, and it is not desirable to let its parameters drift until the shutdown, as this can lead to financial losses and safety risks. It is then not possible to early estimate the parameters of the degradation model and should be estimated online through the proposed methodology.

### 5.3. Online parameter estimation and SRUL prediction of the TEP

To predict the TEP SRUL online, the methodology described in Sections 3 and 4 is utilized. This methodology's input is only the structure of the IIM, i.e., the number of critical components to monitor, failure threshold, and the trends of the component degradations.

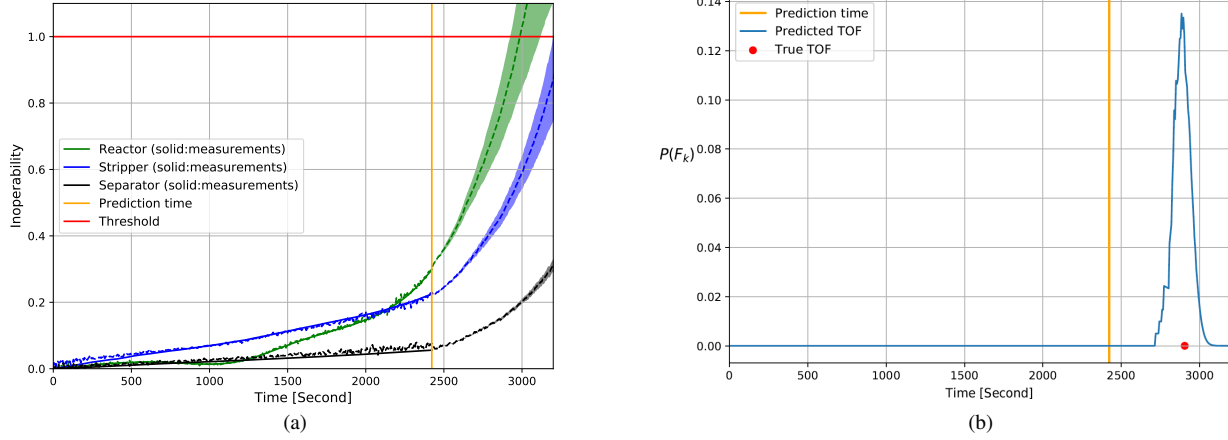

Figure 4. Predicted component inoperabilities (a) and ToF PDF (b) at  $t_p = 2440s$ .

In order to enhance the result accuracy, a digital filter is applied to the real data in order to reduce their noise. In this case, a Savitzky-Golay filter (Savitzky & Golay, 1964) is chosen because it allows increasing the precision of the data without distorting the signal trend.

In order to reduce the computation time related to the application of the proposed methodology, one must evaluate the outputs of the estimated IIM with respect to the monitoring data to investigate whether it is necessary to update the IIM. The procedure of the IIM update and the SRUL prediction is set as follows:

- When a discrepancy between the predicted value by the IIM and the monitoring data is greater than  $1\sigma$  on both sides of the mean value (i.e.  $\theta = 0.01$ ), which represents the process measurement standard deviation, the parameter  $\delta$  is incremented by 1, and a long-term prediction of the system health state is performed.
- When three successive discrepancies are detected (i.e.  $\delta = 3$ ), the IIM parameters will be updated using the GD method.

Concerning the GD-based parameter estimation method, we consider as a stopping criterion the difference of the MSE in two successive iterations less than  $10^{-10}$ , and the learning rate is set to 0.005 (i.e.,  $\gamma = 0.005$ ). The initial values of the component internal degradation parameters, i.e.  $\alpha$ ,  $\beta$  and  $\epsilon$  in equations 14 and 15, are set randomly (in order to show the robustness of the estimation method). The IIM parameters are updated throughout the TEP operation, and, at the end of the implementation, the internal degradation models of the

components obtained as follows:

$$c(t) = \begin{bmatrix} c_1(t) \\ c_2(t) \\ c_3(t) \end{bmatrix} = \begin{bmatrix} 1.018 \cdot c_1(t-1) + 0.001 \\ 0.9 \cdot c_2(t-1) \\ 0 \end{bmatrix}$$

Also, the estimated interdependencies matrix  $A$  is:

$$A = \begin{bmatrix} 0 & 8 \cdot 10^{-3} & 2 \cdot 10^{-8} \\ 3 \cdot 10^{-4} & 0 & 3 \cdot 10^{-8} \\ 2 \cdot 10^{-4} & 10^{-4} & 0 \end{bmatrix}$$

One can notice that the last column elements of the estimated matrix  $A$  are smaller compared to the other matrix elements. This is due to the fact that in this simulation, the separator is not degrading by itself and thus does not significantly influence the degradation of the other components. However, its influence on the other component degradations is not null, i.e.  $a_{i3} \neq 0$ . In fact, the separator degrades because of the influence of the other components, and as a result, it, in turn, influences them.

Figure 4a shows the estimated and measured inoperability of the TEP units at the first prognostics time  $t_p = 2440s$ , which corresponds to when the reactor pressure goes out of its normal operating limit given in Table 1. One can notice that the estimation given by using the IIM (determined by GD) and the particle filtering corresponds to the actual measurements of the component inoperabilities despite the system's nonlinearity properties. Also, in Figure 4b, we can notice that the predicted ToF (equal to 2895s) PMF is close to the true ToF (equal to 2905s), and is slightly pessimistic. This result allows early scheduling of maintenance actions and, therefore, puts the system, its operators, and its environment in a safer situation. The evolution of the predicted SRUL is shown in Figure 5. One can notice that the predicted SRUL



becomes more and more accurate over time, when more and more data are collected, and converges to the true SRUL. In this case, the SRUL corresponds to the RUL of the first failed component. Indeed, the TEP can be considered as a series-configuration one because the operability of the system depends on the operability of all its components.

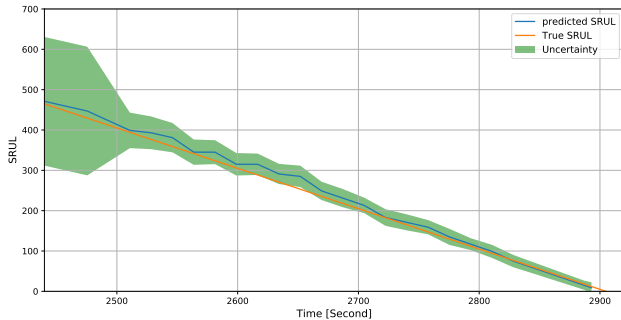

Figure 5. SRUL prediction performance with  $\alpha=0.1$ .

By applying the proposed methodology, the IIM parameters were updated only 89 times out of a total of 494 data samples. The long-term prediction of component inoperabilities was made only 23 times, versus 82 cycles of the system after the anomaly was detected. The total computation time was 140 seconds by using an Intel core iZ 7700 and 16 Gb RAM. Knowing that the system fails after 2905 seconds of operation, it is reasonable to consider low computational resources while ensuring a good prediction of the SRUL, even though the TEP is a highly critical facility, and the resources allocated here are reasonable to deploy in reality.

## 6. CONCLUSION

In this paper, a new methodology for online system remaining useful life (SRUL) prediction is proposed. In that perspective, a unified model for the system degradation, which considers interdependencies between components, mission profile, and inner component degradations, namely the inoperability input-output model, is proposed. This methodology combines system degradation parameter determination (using gradient descent method), system health state estimation and prediction (using particle filtering), and SRUL calculation based on the system configuration. Process and data uncertainty is accounted for, while minimal input information on system degradation is required. Finally, this methodology is designed to be computationally resource-efficient while ensuring an accurate prediction of the SRUL thanks to its capacity to identify suitable moments to update the model and to predict SRUL. The applicability and the performance of the proposed methodology for real industrial systems were validated using data from the well-known Tennessee Eastman process. In detail, the obtained degradation model has

proper physical meaning in relation to the system degradation mechanisms. Besides, the predicted SRUL converges to the true value rapidly, even when considering low computation resources.

Several perspectives can be raised by this work. First, in order to reduce the requirements on the knowledge available on the system, one can propose a general regression model for the component degradations. Also, sensitivity analysis can be conducted to find the best parameters of the methodology to utilize to get accurate results with low computation resources.

## ACKNOWLEDGMENT

F. Tamssaouet wants to thank Dr. M. Orchard for his kind invitation in his laboratory (Center of Energy at the University of Chile). This work has been supported by FONDECYT Chile Grant Nr. 1170044, ANID-Basal Project FB0008, and LGP-ENIT France (Support for International Mobility)

## REFERENCES

- Acuña, D. E., & Orchard, M. E. (2017). Particle-filtering-based failure prognosis via Sigma-points: Application to Lithium-ion battery state-of-charge monitoring. *Mechanical Systems and Signal Processing*, 85, 827 - 848.
- Atamuradov, V., Medjaher, K., Dersin, P., Lamoureux, B., & Zerhouni, N. (2017). Prognostics and health management for maintenance practitioners-review, implementation and tools evaluation. *International Journal of Prognostics and Health Management*, 8(60), 1–31.
- Bathelt, A., Ricker, N. L., & Jelali, M. (2015). Revision of the Tennessee Eastman Process model. *IFAC (International Federation of Automatic Control) Papers Online*, 48(8), 309–314.
- Daigle, M., Bregon, A., & Roychoudhury, I. (2012). A distributed approach to system-level prognostics. In *Annual conference of the prognostics and health management society* (pp. 71–82).
- Das, D., Elburn, E., Pecht, M., & Sood, B. (2019). Evaluating impact of information uncertainties on component reliability assessment. In *International reliability physics symposium (irps)*.
- Doucet, A., Godsill, S., & Andrieu, C. (2000). On sequential Monte Carlo sampling methods for Bayesian filtering. *Statistics and Computing*, 10(3), 197–208.
- Downs, J. J., & Vogel, E. F. (1993). A plant-wide industrial process control problem. *Computers & Chemical Engineering*, 17(3), 245–255.
- Liu, J., & Zio, E. (2016). Dynamic reliability assessment and prognostics with monitored data for multiple dependent degradation components. In *European safety and reliability conference*.
- Orchard, M. (2006). *A particle filtering-based framework*

- for on-line fault diagnosis and failure prognosis* (Unpublished doctoral dissertation). Georgia Institute of Technology, Atlanta, CA.
- Orchard, M. E., & Vachtsevanos, G. J. (2009). A particle-filtering approach for on-line fault diagnosis and failure prognosis. *Transactions of the Institute of Measurement and Control*, 31(3-4), 221–246.
- Pecht, M. (2009). Prognostics and health management of electronics. In *Encyclopedia of structural health monitoring* (pp. 263–286). John Wiley & Sons.
- Rodrigues, L. R. (2018). Remaining useful life prediction for multiple-component systems based on a system-level performance indicator. *IEEE/ASME Transactions on Mechatronics*, 23(1), 141–150.
- Ruder, S. (2016). An overview of gradient descent optimization algorithms. *arXiv preprint arXiv:1609.04747*.
- Savitzky, A., & Golay, M. J. (1964). Smoothing and differentiation of data by simplified least squares procedures. *Analytical Chemistry*, 36(8), 1627–1639.
- Snyman, J. A., & Wilke, D. N. (2018). *Practical mathematical optimization: Basic optimization theory and gradient-based algorithms* (Vol. 133). Springer.
- Tamssaouet, F., Nguyen, K. T., Medjaher, K., & Orchard, M. (2020). Online joint estimation and prediction for system-level prognostics under component interactions and mission profile effects. *ISA Transactions*.
- Tamssaouet, F., Nguyen, T. P. K., & Medjaher, K. (2019). System-level prognostics under mission profile effects using inoperability input-output model. *IEEE Transactions on Systems, Man, and Cybernetics: Systems*, 1–11.