



HAL
open science

Optimal decision tree design for near real-time control of battery energy storage systems

Katrin Handel, Angelina Ebenezer, Rémy Rigo-Mariani, Katrin Schulte, Jens
Haubrock

► **To cite this version:**

Katrin Handel, Angelina Ebenezer, Rémy Rigo-Mariani, Katrin Schulte, Jens Haubrock. Optimal decision tree design for near real-time control of battery energy storage systems. 26TH INTERNATIONAL SYMPOSIUM ON SYMBOLIC AND NUMERIC ALGORITHMS FOR SCIENTIFIC COMPUTING, Sep 2024, Timisoara, Romania. hal-04773286

HAL Id: hal-04773286

<https://hal.science/hal-04773286v1>

Submitted on 8 Nov 2024

HAL is a multi-disciplinary open access archive for the deposit and dissemination of scientific research documents, whether they are published or not. The documents may come from teaching and research institutions in France or abroad, or from public or private research centers.

L'archive ouverte pluridisciplinaire **HAL**, est destinée au dépôt et à la diffusion de documents scientifiques de niveau recherche, publiés ou non, émanant des établissements d'enseignement et de recherche français ou étrangers, des laboratoires publics ou privés.

Optimal decision tree design for near real-time control of battery energy storage systems

Katrin Handel^{1,*}, Angellina Ebenezer Anitha¹, Rémy Rigo-Mariani², Katrin Schulte¹, Jens Haubrock¹

¹University of Applied Sciences and Arts Bielefeld, Institute for Technical Energy Systems, Bielefeld, Germany

²University Grenoble Alpes, CNRS, Grenoble INP, G2Elab, Grenoble, France

*katrin.handel@hsbi.de

Abstract—The increasing numbers of distributed energy resources (DER) incur new challenges for the energy supply due to the volatilities and uncertainties of renewable energies. To utilize the benefits of DER, a combination with storage systems and intelligent controls are necessary. Commonly used control methods are based on Model Predictive Control (MPC) with forecast and optimization, which require computational capabilities at the DER on a level, on which the distribution system operator (DSO) has no access. This paper proposes a control algorithm based on data, which combines a model-based and an artificial intelligence (AI) based approach to utilize benefits from both methods while compensating for their drawbacks. Mixed-Integer Quadratic Programming (MIQP) is used to generate training and testing data for a decision tree (DT). The investigation of the optimal composition of the training data and the optimal architecture of the DT are the main focus of this paper.

Keywords—battery energy storage system control, decision tree, mixed-integer quadratic programming, power smoothing

I. INTRODUCTION

As a result of both European and German regulations, the number of renewable DER in Germany continues to rise. In the first quarter of 2024 58.4 % of the generated electricity originated from renewable sources [1]. In 2023, 12 % of gross electricity generation was from photovoltaics (PV) [2]. With the addition of an installed capacity of 14.6 GWp in 2023, the total installed photovoltaic capacity in Germany is about 82 GWp, this corresponds to over 3.7 million systems, including smaller plug-in devices [2]. Moreover these DER are not only installed at higher grid levels, providing a top-down energy supply but also at the low-voltage level on a household scale, which the DSO is not able to influence. This change in the energy supply comes with both benefits and disadvantages. Due to the volatility of DER generation peaks can occur. Therefore the volatile energy generation of DER can result in line congestions, reverse power flows and voltage fluctuations. On the beneficial side, DER on the end-user scale allow a more efficient energy usage, which can target customer benefits, such as reduced energy bills, as well as grid services for the DSO, such as power smoothing. Thus, for an advantageous usage of DER and storage capacity and a combination of customer and DSO oriented control approaches, an intelligent control is necessary.

One way to implement such a control is by using a MPC approach. As the name suggests, these control methods use mathematical models of a system to predict the optimal

operating state over a receding time horizon [3]. The method presented in [4] is an example for such a MPC based control. Here, the MPC method is used for an energy management strategy of a household containing a PV system, a battery energy storage system (BESS) and several controllable loads. Besides an optimal power distribution, a minimization of energy costs and an increased self-consumption is targeted, by computing setpoints for the controllable loads. For this, forecasts of the load and PV power are used. A different approach is taken in [5], where instead of an optimal power distribution at the household level, the MPC aims at an optimal power flow at the transformer level. A forecast of the loadflow at the transformer of a low-voltage grid and a linear optimization algorithm are used to determine the charging and discharging powers of distributed BESS at household level to minimize reverse power flows caused by high PV penetrations in a low-voltage grid.

While MPC methods are well suited to maintain the comprehensibility of their results, they could be heavy in computation and require an intensive knowledge of the system [3]. For complex systems, the construction and calibration of accurate mathematical equations may be a laborious and even infeasible task, leading to an unavoidable degree of uncertainty in the forecasts [6]. Thus, other controls use AI to achieve an optimal operating state. Especially reinforcement learning (RL) approaches can be found throughout recent literature. In [7] a cost-oriented RL strategy is introduced. Through a multi-model RL framework and a switching strategy, an optimal model for the current operating conditions of a household BESS is selected from pre-trained RL agents in real-time. Other than in [7], where the RL agent is learning through its interactions with the real environment consisting of a PV system and a BESS, the approach in [8] uses action masking for training without a model of the environment.

While AI methods can handle big and even abstract data sets, do not necessarily require an explicit model of the system and are overall lightweight computational methods once trained, they are not as intuitively understandable as MPCs. Their architecture and the reason behind their output often lack explainability. Due to this, methods of combining MPC and model-free controls are investigated in research as well. In [9] the performances of an MPC-based controller and a model-free, data driven controller for residential BESS in a PV-rich microgrid are compared. The objective of the controls is to control the charging and discharging of the BESS in such a way, that the power exchange with the grid follows an expected average net load, determined by the DSO. In [10] a neural network MPC is developed for PV power smoothing

This work was supported by the German Federal Ministry of Education and Research (BMBF) under the German-French Joint Call for Proposals on “Artificial Intelligence”.

with BESS. Instead of a mathematical model, the MPC uses a neural network to model the system.

To gain the most benefit from an intelligent storage control, the combination of the advantages from both MPC and AI-based methods seems to be a promising approach. To leverage both the explainability from MPC and the low computational effort of a trained AI, the work in [11] uses MPC to generate day-ahead prediction profiles and a DT, which is pre-trained offline and fine-tuned online for the control of a BESS and a heating, ventilation and air-conditioning system of a building. The offline training is conducted with the results of the MPC, which is run with historical forecasts and measurements, while the fine-tuning takes place once the DT is applied to the actual system.

Based on the work in [11], this paper proposes a control algorithm that uses a lightweight DT, which is pre-trained with optimal results from an MPC method, for the control of a BESS at household level. The algorithm is opted at smoothing both the power imported from the grid and the power exported due to PV generation surplus. Thus, compared to a regular BESS control, the algorithm not only ensures a maximization of the self-consumption of PV power but is also able to reduce the effect of DER on the grid by mitigating power peaks. MIQP is used to generate training and testing data for the DT, based on historical measurement data of the load and PV power at one household. Once trained, the DT can be applied to a BESS to determine the optimal charging or discharging power based on measurements of the load, the state of charge (SOC) and the PV generation power. Thus, the proposed control algorithm is independent of forecasts and only relies on historical measurement data for the MIQP-based generation of the training set for the DT and on current measurement data as input for the control application on the real system. This paper builds upon the work presented in [11] and focuses on generating different data sets for training and testing a regular DT and evaluating the impact of different parameters on the DT's performance. In contrast to [11], the MPC is only used for the generation of the training set and not for a first stage forecast within the control. The performance of the proposed method is assessed by comparing the results for the optimization variable of the MIQP with the results from the DT trained and tested with different data sets. Besides, the optimal number of leaves of the DT is determined. The objective is to keep the MIQP algorithm, the DT and the training and testing data sets as simple as possible to keep the computational effort at a minimum. The main contributions of this paper are:

- The analysis of the influence of different training and testing data set compositions on the performance of the DT.
- The determination of the optimal tree architecture, concerning the number of leaves.

This paper is organized as follows. In section II the methodology of creating the MIQP algorithm as well as the DT and the different data sets is described. Section III presents the results of training and testing the DT with the different data sets. In section IV the results are concluded and an outlook on further research on the topic is given.

II. METHODOLOGY

The following section describes the overall composition of the proposed method, the MIQP algorithm and the generation

of the different data sets. Furthermore the construction of the DT is described as well as its training and testing. In Fig. 1 an overview of the power flows regarded in this work is given.

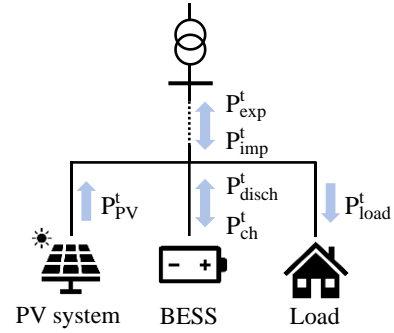

Fig. 1: Overview of power flows at the considered system

The proposed control algorithm consists of two parts, a MIQP algorithm for the generation of the training and testing data sets and a DT for the actual control. The DT is applied to a BESS on household level to determine the charging or discharging power of the BESS based on the measurement data of the PV power, the load and the SOC. The charging and discharging of the BESS is opted at smoothing the power profile at the household connection point. The overall idea is to improve the integration of DER from the grid perspective, while reducing the energy exchanges and peak power for both import and export power from and to the upstream grid. To achieve this behavior, the DT is trained with an optimal charging and discharging power profile and varying data sets, which are further described in section II B. This optimal charging and discharging power profile is generated by an MIQP algorithm, which uses historical measurement data of the load and PV power of one household. The historical measurement data is based on the simbench load and PV profiles in [12] and covers one year.

A. Mixed-Integer Quadratic Programming to generate the training data set

The MIQP algorithm uses a historical PV power generation profile P_{PV}^t and a historical load profile P_{load}^t of a single household to generate an optimal charging profile containing the charging powers P_{ch}^t and the discharging powers P_{disch}^t for one BESS. Besides the load and PV profiles, the optimization parameters include the charge and discharge efficiencies η_{ch} and η_{disch} , the maximum charging and discharging powers $P_{ch,max}$ and $P_{disch,max}$, the maximum utilizable storage capacity E_{max} and the maximum and minimum SOC's SOC_{max} and SOC_{min} . The optimization variables include the power import from the grid P_{imp}^t , the power export to the grid P_{exp}^t , the charging and discharging powers P_{ch}^t and P_{disch}^t as well as the SOC SOC^t . Moreover a binary variable u^t is used to differentiate between charging and discharging times. The time horizon T of the optimization covers six months with timesteps t of 15 minutes each. As the first half of the data set is used for training and the second half for testing the DT, the MIQP algorithm is run separately for the first and the second half of the year. The objective of the optimization is to smooth both the power import P_{imp}^t and export P_{exp}^t at the household connection point. Thus the objective function minimizes the sum of the squared values of the power import P_{imp}^t and export P_{exp}^t at each timestep t , as shown in (1). The constraints define the power balance of the system and differentiate between charging and discharging

times as well as between a power import and an export from and to the grid. Furthermore the SOC of the BESS is defined. The constraints are presented in (2).

$$\begin{aligned}
\text{Obj: } & \min \left(\sum_{t \in T} P_{\text{imp}}^t{}^2 + \sum_{t \in T} P_{\text{exp}}^t{}^2 \right) \quad (1) \\
\text{s.t.: } & \left\{ \begin{array}{l}
P_{\text{imp}}^t + P_{\text{PV}}^t + P_{\text{disch}}^t = P_{\text{load}}^t + P_{\text{ch}}^t + P_{\text{exp}}^t, \forall t \in T \\
P_{\text{ch}}^t \leq P_{\text{ch, max}} \cdot u^t, \forall t \in T \\
P_{\text{disch}}^t \leq P_{\text{disch, max}} \cdot (1 - u^t), \forall t \in T \\
P_{\text{exp}}^t \leq P_{\text{PV, max}} \cdot u^t, \forall t \in T \\
P_{\text{imp}}^t \leq P_{\text{load, max}} \cdot (1 - u^t), \forall t \in T \\
\text{SOC}^{t+1} = \text{SOC}^t + \left(\frac{P_{\text{ch}}^t \cdot \eta_{\text{ch}} - \frac{P_{\text{disch}}^t}{\eta_{\text{disch}}}}{E_{\text{max}}} \right) \cdot 100, \forall t \in T \\
\text{SOC}^t \leq \text{SOC}_{\text{max}}, \forall t \in T \\
\text{SOC}^t \geq \text{SOC}_{\text{min}}, \forall t \in T \\
\text{SOC}^0 = \text{SOC}_{\text{start}}
\end{array} \right. \quad (2)
\end{aligned}$$

The optimization problem is formulated in Python and solved with Gurobi.

B. Decision tree

A DT algorithm is a non-linear and non-parametric supervised learning algorithm that aims to make predictions based on certain decision rules derived from a given data set [13]. The name of the algorithm is derived from its flowchart structure, which resembles a tree with nodes and leaves. The first stage of the algorithm is referred to as the DT induction, where the DT is built. The input data undergoes a recursive partitioning process, starting from a root node and proceeding to two "child" nodes. This split is traditionally conducted as a binary answer (true/false, yes/no) to a logical question. At each child node, a new logical test is applied, and the data is further split into new child nodes. If the logical test at a node is unable to further split the data, the subset is considered "pure" and forms a "leaf." The leaves contain the predictions associated with each partitioning of the input space. It has been observed, that shallow trees, or a limited number of partitioning, can often result in a more robust generalized model, as they are less susceptible to overfitting [14]. The general architecture of a DT is depicted in Fig. 2.

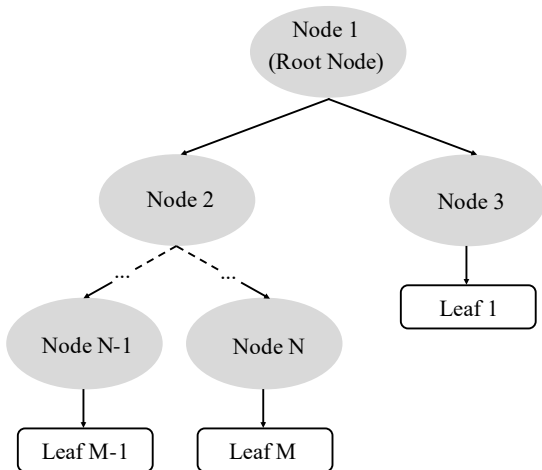

Fig. 2. General architecture of DT

To achieve a shallower tree, certain hyperparameters, such as the maximum depth of a tree, the minimum number of samples required in a leaf node, and so forth, can be adjusted. This simple underlying structure makes DTs easy to interpret and comprehend. Shallow trees are especially regarded highly for their simplicity and interpretability [15].

In this paper, a regular DT regression algorithm is used to determine the charging and discharging powers of a BESS. The target function therefore contains the BESS power profile, as shown in (3). The DT is both trained and tested for six months each. When applied to a real system, the DT receives inputs and generates outputs in 15 minute time intervals.

$$y = [P_{\text{BESS}}^t] \quad (3)$$

Besides the optimal BESS power profile, which is obtained from the MIQP algorithm, the training data set is comprised of historical measurement data of the load and PV power in different forms. For these inputs, four different data sets are investigated. The first case X_{base} serves as a baseline case, where only the measurement values of the PV generation power P_{PV}^t , the load P_{load}^t and the SOC SOC^t for each timestep are considered (4). In the second case X_{sin} , the input data is extended by a sine wave for the time index T^t , which is used to convey the circularity of the data (5). As one day is comprised of 96 timesteps of 15 minutes each, the sine wave has a period of 96 multiplied by two. In the third case X_{flowdiff} the PV and load profiles are exchanged for a profile, which contains the load profile subtracted by the PV profile P_{flowdiff}^t (6). The last case X_{t-1} is an extension of X_{sin} , where in addition to the current measurement data of the PV power and the load, their previous values P_{PV}^{t-1} and P_{load}^{t-1} are used (7). All cases are listed below.

$$X_{\text{base}} = [P_{\text{PV}}^t \quad P_{\text{load}}^t \quad \text{SOC}^t] \quad (4)$$

$$X_{\text{sin}} = [P_{\text{PV}}^t \quad P_{\text{load}}^t \quad \text{SOC}^t \quad T^t] \quad (5)$$

$$X_{\text{flowdiff}} = [P_{\text{flowdiff}}^t \quad \text{SOC}^t \quad T^t] \quad (6)$$

$$X_{t-1} = [P_{\text{PV}}^{t-1} \quad P_{\text{load}}^{t-1} \quad P_{\text{PV}}^t \quad P_{\text{load}}^t \quad \text{SOC}^t \quad T^t] \quad (7)$$

For each of these cases, DTs with different architectures are trained using the results of the MIQP algorithm as well as the load and PV profiles. The architecture is considered by increasing the number of leaves from 10 to 1000. The DTs are set up using the sklearn package for DT regression models. The first six months of a data set are used for training, while the remaining six months are kept for testing the performance of the DT.

III. RESULTS

The performance of the differently trained DTs is assessed through a simulation of their individual application to a BESS after training with the results from the MIQP algorithm. For both the generation of the training data with the MIQP algorithm and the simulation of the application of the DT to a BESS at household level, a peak load of 3 kW and a peak PV power of 3 kW_p is chosen from the simbench profiles as well as a utilizable capacity for the BESS of 6 kWh. The greater capacity compared to the peak power of the PV system is chosen so that the BESS can also effectively be used for PV power smoothing and thus combining customer-oriented services with DSO-oriented services. For the BESS

parameters, references are taken from the data sheets of leading German BESS manufacturers [16] [17]. The maximum charging and discharging powers are 4.6 kW, the charging and discharging efficiencies 97 %. The time horizon of training and testing covers six months for each case with timesteps of 15 minutes. At every timestep, the DT is tested with the input parameters at the respective step with an updated SOC depending on the previously determined power P_{BESS}^t . With the results from the simulation, the power exchange with the grid and the respective energy exchange is calculated. The performance of the DTs is evaluated on the basis of (1). As performance metric, the sum of squared energy exchanges with the grid over the considered time horizon of six months E^2 is used. In Fig. 3 the squared energy exchange with the grid of each case is depicted for different numbers of leaves.

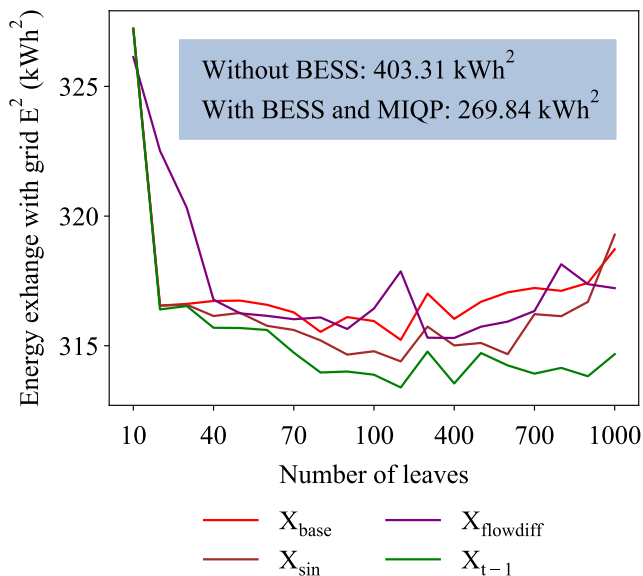

Fig. 3. Comparison of performance of DTs with different input data and architectures

Fig. 3 shows, that the performance for each DT case first significantly improves with an increasing number of leaves and then generally decreases for greater numbers of leaves with varying profiles. For X_{base} this decrease happens at a number of leaves greater than 200. The best performance is achieved with X_{t-1} at 200 leaves. In this case, the energy exchange is reduced from 403.31 kWh² of the case with no BESS to 313.39 kWh², which is a reduction of approx. 22 % compared to a reduction of 33 % with optimal management of the BESS, where the energy exchange is 269,84 kWh². In Fig. 4 timeseries examples for the power exchange with the grid, the BESS charging and discharging powers and the respective SOC are given for the DT case X_{t-1} with 200 leaves in comparison with the optimal BESS management with the MIQP. Besides, the power exchange with the grid in case of no BESS is depicted. A positive value describes a power export to the grid, a negative value a power import, accordingly a positive BESS power value describes a charging power and a negative value a discharging power. For this comparison, the day with the highest PV generation peak is chosen. It is evident, that in the case X_{t-1} the charging and discharging powers follow the optimal profile closely with few deviations. However, the charging power is at all times slightly higher than in the optimal profile, which leads to overcharging of the BESS. After approx. 09:30 AM, the charging ceases entirely in case X_{t-1} . One reason for this can

be derived from the initial SOC at the beginning of the considered day, which is considerably higher in X_{t-1} than in case of optimal management. Overall, the simulation of the application of a pre-trained DT to a BESS shows promising results, which are to be further improved.

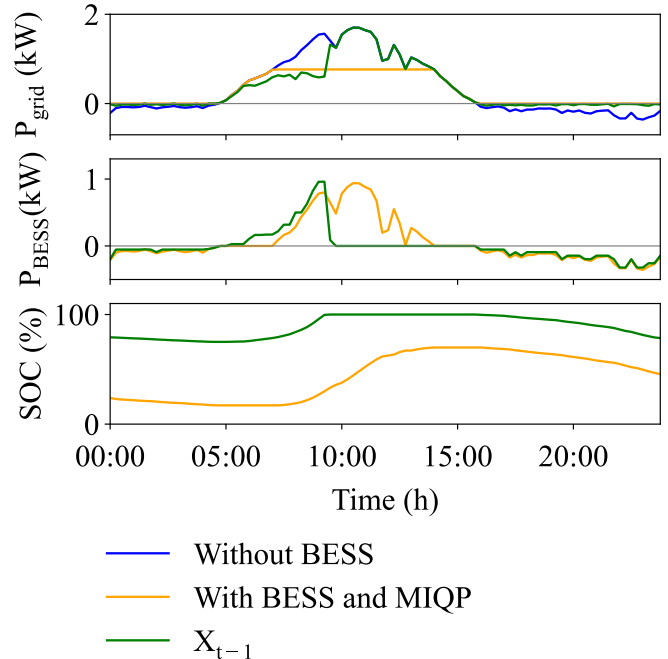

Fig. 4. Timeseries profile for one day for different cases

IV. CONCLUSION

This paper proposes a method for a BESS control at household level, which utilizes the benefits of both model-based approaches and AI-based approaches. A MIQP algorithm is used to generate data sets out of historical measuring data of the load and PV generation power, which are used for training and testing different DTs. Such a DT can then be used to smooth the power profile at a household connection point by determining the appropriate charging state and power of a BESS based on measuring data of the PV generation power and the load. The influence of different training inputs and different DT architectures on the DT's performance is investigated. For this, four cases are considered as input data for DTs. The results closest to the optimal results of the MIQP are achieved with case X_{t-1} , where the PV power, load and SOC at the current timestep as well as a sine wave as time index and the values of the load and PV power at the previous timestep are used as input values. However, while reducing the energy exchange with the grid, the DT algorithm does not achieve a smooth power profile. As further research, the influences of additional parameters on the DTs accuracy can be investigated. Such parameters can either refer to the data set generation, additional training inputs or the DTs architecture. Thus instead of the MIQP algorithm regarded in this paper, different MPC approaches with different optimization formulations can be analyzed concerning their influence on the DTs performance. Another parameter that could be investigated is time encoding method of the time index, which is included in the training data input. Lastly, the analysis can be carried out with different types of trees, like linear regression trees and with different training periods.

REFERENCES

- [1] German Federal Statistical Office, "Electricity generation in the first quarter of 2024: almost 60% from renewable energy sources," Wiesbaden, 2024.
- [2] H. Wirth, "Current facts on photovoltaics in Germany," Fraunhofer ISE, 2024.
- [3] M. Schwenzer, M. Ay, T. Bergs and D. Abel, "Review on model predictive control: an engineering perspective," *The International Journal of Advanced Manufacturing Technology*, pp. 1327-1349, 11 August 2021.
- [4] H. Yan, F. Zhuo, N. Lv, H. Yi, Z. Wang and C. Liu, "Model Predictive Control Based Energy Management of a Household Microgrid," in *2019 IEEE 10th International Symposium on Power Electronics for Distributed Generation Systems (PEDG)*, Xi'an, China, 2019, pp. 365-369.
- [5] K. Handel, K. Schulte, R. Rigo-Mariani, J. Haubrock and J. Arens, "Control of distributed energy storage systems for minimum reverse flow in a distribution grid with high share of photovoltaic," in *2023 IEEE PES Innovative Smart Grid Technologies Europe (ISGT EUROPE)*, Grenoble, France, 2023, pp. 1-5.
- [6] G. Pinto, D. Deltetto and A. Capzoli, "Data-driven district energy management with surrogate models and deep," *Applied Energy*, no. 304, 2021.
- [7] S. Paesschesoone, N. Kayedpour, C. Manna and Crevecœur, "Improving Energy Flexibility in Photovoltaic-Battery Systems through Switching Reinforcement Learning Control," in *2024 IEEE Conference on Technologies for Sustainability (SusTech)*, Portland, OR, USA, 2024, pp. 57-62.
- [8] S. R. Kumar, R. Rigo-Mariani, B. Delinchant and A. Easwaran, "Towards Safe Model-Free Building Energy Management using Masked Reinforcement Learning," in *2023 IEEE PES Innovative Smart Grid Technologies Europe (ISGT EUROPE)*, Grenoble, France, 2023, pp. 1-5.
- [9] S. S. Sajjadi, N. Bazmohammadi, A. M. Amani, M. Jalili, J. M. Guerrero and X. Yu, "Control of Battery Storage Systems in Residential Grids: Model-based vs. Data-Driven Approaches," in *2022 IEEE 20th International Conference on Industrial Informatics (INDIN)*, Perth, Australia, 2022, pp. 157-161.
- [10] M. A. Syed and M. Khalid, "Neural network predictive control for smoothing of solar power fluctuations," in *Journal of Energy Storage*, Elsevier, 2021.
- [11] R. Rigo-Mariani and A. Yakub, "Decision Tree Variations and Online Tuning for Real-Time Control of a Building in a Two-Stage Management Strategy," *Energies*, 2024.
- [12] S. Meinecke, D. Sarajlić, S. R. Drauz, A. Klette, L.-P. Lauen, C. Rehtanz, A. Moser and M. Braun, "Simbench - A Benchmark Dataset of Electric Power Systems to Compare Innovative Solutions based on Power Flow Analytics," *Energies*, p. 3290, June 2020.
- [13] S. Suthaharan, *Machine Learning Models and Algorithms for Big Data Classification*, New York: Springer, 2016.
- [14] V. G. Costa and C. E. Pedreira, "Recent advances in decision trees: an updated survey," *Artificial Intelligence Review*, pp. 4765 - 4800, 10 October 2023.
- [15] A. A. Freitas, "Comprehensible classification models: a position paper," *Association for Computing Machinery*, New York, NY, USA, 2014.
- [16] sonnen GmbH, "Technical Data sonnenBatterie 10".
- [17] Hager Energy GmbH, "Technical data home power plant of the SE-series stand alone hybrid".