



**HAL**  
open science

# Strong Structural Controllability Analysis of Structured Networks with Identical Nodes

Guangchen Zhang, Jiajia Jia, Junjie Jiao, Yahao Chen

► **To cite this version:**

Guangchen Zhang, Jiajia Jia, Junjie Jiao, Yahao Chen. Strong Structural Controllability Analysis of Structured Networks with Identical Nodes. 2024. hal-04707907

**HAL Id: hal-04707907**

**<https://hal.science/hal-04707907v1>**

Preprint submitted on 24 Sep 2024

**HAL** is a multi-disciplinary open access archive for the deposit and dissemination of scientific research documents, whether they are published or not. The documents may come from teaching and research institutions in France or abroad, or from public or private research centers.

L'archive ouverte pluridisciplinaire **HAL**, est destinée au dépôt et à la diffusion de documents scientifiques de niveau recherche, publiés ou non, émanant des établissements d'enseignement et de recherche français ou étrangers, des laboratoires publics ou privés.



Distributed under a Creative Commons Attribution 4.0 International License

# Strong Structural Controllability Analysis of Structured Networks with Identical Nodes

Guangchen Zhang, Jiajia Jia\*, Junjie Jiao, and Yahao Chen

**Abstract**—In this note, necessary and sufficient rank conditions are proposed for checking the strong structural controllability of structured networks with identical nodes. More specifically, for a network with multi-input multi-output (MIMO) nodes, under an assumption called the strong invertibility for the nodal systems, the strong structural controllability of a given structured network is shown to be solely determined by its own topology. For the single-input single-output (SISO) case, such an assumption is allowed to be dropped by incorporating certain controllability and observability conditions for the nodal systems. Additionally, we utilize a recently developed graph-theoretical method for structured systems to verify the proposed rank conditions.

**Index Terms**—Controllability analysis, strong structural controllability, homogeneous networks, graph theory

## I. INTRODUCTION

OVER the past few decades, controllability analysis of large-scale networks has captured considerable interests from a multitude of scholars, leading to a substantial amount of literature, see, e.g., [1]–[4] and the references therein. Research on network controllability encounters significant challenges due to the incomplete information on the network interconnection structure and the dynamical behaviors exhibited by nodal systems. Due to such reasons, some scholars use structural analysis methods [5], [6] to model the aforementioned incomplete information, which facilitates the controllability analysis on such networks [7]–[10]. In particular, by utilizing zero/nonzero/arbitrary pattern matrices [11], [12] to describe such incomplete information, the controllability analysis of a single network is transformed into that of a family of networks, which is called the *structured networks* [13], [14].

Two types of controllability, namely, weak and strong structural controllability, have been studied extensively for structured networks. We call a member of the family related to a given structured network a *realization* of it. A structured network is called weakly structurally controllable [15] if it contains at least one controllable realization. On the other hand, it is called strongly structural controllable [16] if all realizations of the structured network are controllable. To our best knowledge, the majority of existing literature simplifies the dynamics of network nodes into one-dimensional integrators, leading to conditions depending on network graphs in order to verify the weak or the strong structural controllability. These conditions can be formulated with the help of graph-theoretical concepts such as cactus graphs, maximum matching, zero-forcing sets, and colorability (see e.g., [7]–[9], [11] and the references therein).

Guangchen Zhang is with North Minzu University, Yinchuan, Ningxia 750021, China (e-mail: ZGC2017006@nmu.edu.cn).

Jiajia Jia is with School of Internet of Things Engineering, and also with School of Food Science and Technology, and also with Key Laboratory of Advanced Process Control for Light Industry (Ministry of Education), Jiangnan University, Wuxi, Jiangsu 214122, China (e-mail: j.jia@jiangnan.edu.cn).

Junjie Jiao is with the Chair of Information-Oriented Control, TUM School of Computation, Information and Technology, Technical University of Munich, 81669 Munich, Germany (e-mail: j.jiao@tum.de).

Yahao Chen is with Nantes University, Centrale Nantes, LS2N UMR CNRS 6004, France (e-mail: yahao.chen@ls2n.fr).

Corresponding author: Jiajia Jia.

Nevertheless, it has been shown in [17] that oversimplifying the nodal dynamics may cause inaccurate controllability analysis because most network nodes are of higher dimensions than integrators. In some recent studies [13], [14], [18], researchers have undertaken investigations on the controllability of structured networks while taking into account both network graphs and internal dynamics of nodal systems. Related research can be roughly categorized into two main directions. The first direction explores heterogeneous structured networks, where nodal systems are allowed to exhibit different dynamical behaviors [13], [14]. For example, researchers have proposed necessary and sufficient conditions for the controllability of a heterogeneous network composed of single-input single-output (SISO) nodes, presenting a scalable analysis method [13]. The second direction revolves around structured networks with identical nodes, wherein all nodes are restricted to have the same dynamical behavior. For instance, the weak structural controllability of structured networks with identical SISO nodes has been studied in [18]. However, the strong structural controllability of structured networks with identical nodes remains an open problem, which will be addressed in this note. In particular, our main contributions are shown as follows.

- Firstly, we outline two necessary conditions for network strong structural controllability, which are rooted in the full rank properties of pattern matrices linked to the network. Moreover, we demonstrate that these conditions are not only necessary but also sufficient for networks with SISO nodes.
- Secondly, a necessary and sufficient condition, depending only on interconnection topology, for checking network strong structural controllability is proposed, under an assumption that the nodal systems are strongly invertible (see Definition 4 below).
- Lastly, a recently proposed [11] color change rule on network graphs is adopted to verify the aforementioned controllability conditions, which facilitates the practical procedure of checking network controllability.

This note is organized as follows. In Section II, we model the structured network with identical nodes and formulate the problem. Our main results are stated in Section III. Section IV contains the proofs of the main results. Finally, we give the conclusions and some discussions of our results in Section V.

**Notations and symbols:** Let  $\mathbb{R}$  and  $\mathbb{R}^n$  denote the set of real numbers and the space of  $n$ -dimensional real vectors, respectively. Likewise, denote by  $\mathbb{C}$  and  $\mathbb{C}^n$  the set of complex numbers and the space of  $n$ -dimensional complex vectors, respectively. For a real vector  $u \in \mathbb{R}^n$ , the transpose of  $u$  is denoted by  $u^\top$ , and for a complex vector  $v \in \mathbb{C}^n$ , the conjugate transpose of  $v$  is denoted by  $v^*$ . In addition, for a given set of vectors  $\{v_1, \dots, v_k\}$ , we denote  $\text{col}(v_1, \dots, v_k) = [v_1^* \ \dots \ v_k^*]^*$ . The set of  $n \times m$  real matrices is denoted by  $\mathbb{R}^{n \times m}$ . We denote the identity matrix of size  $n \times n$  by  $I_n$ . Denote by  $\otimes$  the Kronecker product of matrices. By a pattern matrix, which plays an important role throughout this note, we mean a matrix with entries in the set of symbols  $\{0, *, ?\}$ . The set of all  $p \times q$  pattern matrices will be denoted by  $\{0, *, ?\}^{p \times q}$ . For a given pattern matrix  $\mathcal{M} \in \{0, *, ?\}^{p \times q}$ , the *pattern class* of  $\mathcal{M}$  is defined

as the subset of  $\mathbb{R}^{p \times q}$  given by

$$\mathcal{P}(\mathcal{M}) = \{M \in \mathbb{R}^{p \times q} \mid M_{ij} = 0 \text{ if } \mathcal{M}_{ij} = 0, \\ M_{ij} \neq 0 \text{ if } \mathcal{M}_{ij} = *\}.$$

This means that for a matrix  $M \in \mathcal{P}(\mathcal{M})$ , the entry  $M_{ij}$  is equal to the real number 0 if  $\mathcal{M}_{ij} = 0$ , a nonzero real number if  $\mathcal{M}_{ij} = *$ , and an arbitrary real number if  $\mathcal{M}_{ij} = ?$ . We say that a pattern matrix  $\mathcal{M}$  has full row rank if every matrix  $M \in \mathcal{P}(\mathcal{M})$  has full row rank.

## II. PROBLEM FORMULATION

In this note, we study structured networks with all nodes being identical. Specifically, consider a network composed of  $N$  identical node systems of the form

$$\begin{aligned} \dot{x}^{(k)} &= Ax^{(k)} + Bv^{(k)}, \\ y^{(k)} &= Cx^{(k)}, \end{aligned} \quad (1)$$

where  $x^{(k)} \in \mathbb{R}^n$ ,  $v^{(k)} \in \mathbb{R}^p$  and  $y^{(k)} \in \mathbb{R}^p$  are vectors of states, inputs, and outputs<sup>1</sup>, respectively, and  $k = 1, \dots, N$ . The system matrices are given by  $A \in \mathcal{P}(\mathcal{A})$ ,  $B \in \mathcal{P}(\mathcal{B})$ ,  $C \in \mathcal{P}(\mathcal{C})$ , where  $\mathcal{A}$ ,  $\mathcal{B}$ ,  $\mathcal{C}$  are pattern matrices of appropriate dimensions. Following the notations in [19], we denote system (1) by  $(A, B, C)$ , and the family of systems which has the same pattern with (1) by  $(\mathcal{A}, \mathcal{B}, \mathcal{C})$ .

Next we introduce the so-called *structured interconnection law*:

$$v^{(k)} = \sum_{j=1}^N W_{kj} y^{(j)} + \sum_{\ell=1}^m H_{k\ell} u^{(\ell)}, \quad (2)$$

where  $u^{(\ell)} \in \mathbb{R}^p$  represents the  $\ell$ -th external input signal with  $\ell = 1, \dots, m$ ,  $W \in \mathcal{P}(\mathcal{W})$ ,  $H \in \mathcal{P}(\mathcal{H})$ ,  $\mathcal{W} \in \{0, *, ?\}^{N \times N}$  and  $\mathcal{H} \in \{0, *, ?\}^{N \times m}$ . By (2), the  $N$  node systems are interconnected into a global system of state dimension  $nN \times nN$  with  $m$  control signals, which can then be represented in a compact form as

$$\dot{x} = (I_N \otimes A + W \otimes BC)x + (H \otimes B)u, \quad (3)$$

where  $x = \text{col}(x^{(1)}, \dots, x^{(N)}) \in \mathbb{R}^{nN}$ ,  $u = \text{col}(u^{(1)}, \dots, u^{(N)}) \in \mathbb{R}^{mN}$ . With a slight abuse of notations, system (3) is denoted by  $(A, B, C, W, H)$ . Moreover, the family of systems with the same pattern as (3) is denoted by  $(\mathcal{A}, \mathcal{B}, \mathcal{C}, \mathcal{W}, \mathcal{H})$ <sup>2</sup>.

To exemplify structured networks with identical nodes, we examine a network of electrical circuits. This example highlights the advantage of using *structured systems* in modeling. In particular, the parameters, such as resistance, capacitance, and inductance, cannot be precisely measured due to potential changes during system operation. However, it is still possible to determine if these parameters are zero or not.

*Example 1:* The network consists of three circuits as depicted in Figure 1. Each circuit contains a resistor, an inductor, and two capacitors. Moreover, we assume that the components within the three circuits are sourced from the same batch and have identical parameter values  $r$ ,  $\ell$ ,  $c_1$ , and  $c_2$ , which are nonzero but not known exactly. Denote the voltages across the capacitors  $c_1, c_2$  and the current through the inductor  $\ell$  in Circuit  $k$ , by  $V_{c_1}^{(k)}$ ,  $V_{c_2}^{(k)}$  and  $I_\ell^{(k)}$ , respectively, with  $k = 1, 2, 3$ .

To excite the circuits, the independent voltage source  $V$  and current source  $I$  are added to Circuit 1. Moreover, to enhance the excitation and to protect the circuits, we adapt  $V$  and  $I$  into  $hV$  and  $hI$ ,

<sup>1</sup>To simplify the system description, we will assume that the input and output dimensions of the node system are equal. This assumption can be conveniently implemented by introducing virtual inputs or outputs if needed.

<sup>2</sup>The notation  $(\mathcal{A}, \mathcal{B}, \mathcal{C}, \mathcal{W}, \mathcal{H})$  is also used in [13] to denote structured networks with heterogeneous nodes, which is different from the networks studied in this note.

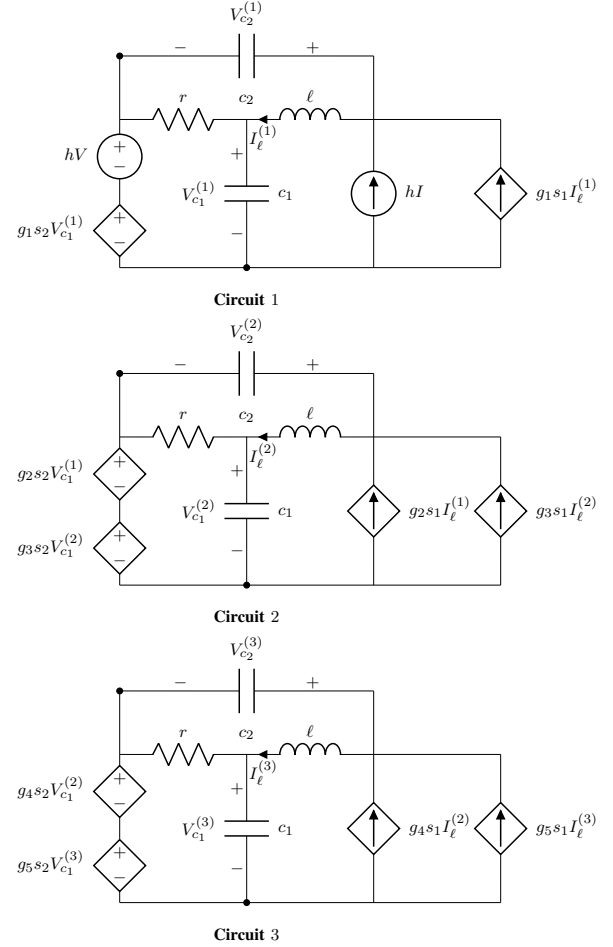

Fig. 1: A network of electrical circuits.

respectively, with a scale parameter  $h \neq 0$ . In addition, to interact the three circuits, we introduce current-controlled current sources

$$g_1 s_1 I_\ell^{(1)}, g_2 s_1 I_\ell^{(1)}, g_3 s_1 I_\ell^{(2)}, g_4 s_1 I_\ell^{(2)}, g_5 s_1 I_\ell^{(3)},$$

and voltage-controlled voltage sources

$$g_1 s_2 V_{c_1}^{(1)}, g_2 s_2 V_{c_1}^{(1)}, g_3 s_2 V_{c_1}^{(2)}, g_4 s_2 V_{c_1}^{(2)}, g_5 s_2 V_{c_1}^{(3)},$$

where  $s_1, s_2$  and  $g_i$  with  $i = 1, \dots, 5$  are nonzero parameters.

Denote the states and the outputs by  $x^{(k)} = [I_\ell^{(k)} \ V_{c_1}^{(k)} \ V_{c_2}^{(k)}]^\top$  and  $y^{(k)} = [s_1 I_\ell^{(k)} \ s_2 V_{c_1}^{(k)}]^\top$  with  $k = 1, 2, 3$ , respectively. Moreover, the external inputs are denoted by  $u = [V \ I]^\top$  and the inner inputs among the three circuits by, respectively,

$$\begin{aligned} v^{(1)} &= [hV + g_1 s_2 V_{c_1}^{(1)} \ hI + g_1 s_1 I_\ell^{(1)}]^\top, \\ v^{(2)} &= [g_2 s_2 V_{c_1}^{(1)} + g_3 s_2 V_{c_1}^{(2)} \ g_2 s_1 I_\ell^{(1)} + g_3 s_1 I_\ell^{(2)}]^\top, \\ v^{(3)} &= [g_4 s_2 V_{c_1}^{(2)} + g_5 s_2 V_{c_1}^{(3)} \ g_4 s_1 I_\ell^{(2)} + g_5 s_1 I_\ell^{(3)}]^\top. \end{aligned}$$

By Kirchhoff's current and voltage laws, the Circuit  $k$  is then represented by the following system

$$\begin{aligned} \dot{x}^{(k)} &= Ax^{(k)} + Bv^{(k)}, \\ y^{(k)} &= Cx^{(k)}, \end{aligned} \quad (4)$$

where  $k = 1, 2, 3$ , and

$$A = \begin{bmatrix} 0 & -\frac{1}{\ell} & \frac{1}{\ell} \\ \frac{1}{c_1} & -\frac{1}{c_1 r} & 0 \\ -\frac{1}{c_2} & 0 & 0 \end{bmatrix}, \quad B = \begin{bmatrix} \frac{1}{\ell} & 0 \\ \frac{1}{c_1 r} & 0 \\ 0 & \frac{1}{c_2} \end{bmatrix}, \quad C = \begin{bmatrix} s_1 & 0 & 0 \\ 0 & s_2 & 0 \end{bmatrix}.$$

Define  $v = \text{col}(v^{(1)}, v^{(2)}, v^{(3)})$ , and thus we have

$$v = (W \otimes I_2)y + (H \otimes I_2)u, \quad (5)$$

$$\text{where } W = \begin{bmatrix} g_1 & 0 & 0 \\ g_2 & g_3 & 0 \\ 0 & g_4 & g_5 \end{bmatrix} \text{ and } H = \begin{bmatrix} h \\ 0 \\ 0 \end{bmatrix}.$$

Recall that the parameters  $r, c_1, c_2, \ell, s_1, s_2, h$  and  $g_i$  with  $i = 1, \dots, 5$  are nonzero but not known exactly. So the global network system is represented as

$$\dot{x} = (I \otimes A + W \otimes BC)x + (H \otimes B)u, \quad (6)$$

where  $A \in \mathcal{P}(\mathcal{A}), B \in \mathcal{P}(\mathcal{B}), C \in \mathcal{P}(\mathcal{C}), W \in \mathcal{P}(\mathcal{W}), H \in \mathcal{P}(\mathcal{H})$ , in which

$$\mathcal{A} = \begin{bmatrix} 0 & * & * \\ * & * & 0 \\ * & 0 & 0 \end{bmatrix}, \quad \mathcal{B} = \begin{bmatrix} * & 0 \\ * & 0 \\ 0 & * \end{bmatrix}, \quad \mathcal{C} = \begin{bmatrix} * & 0 & 0 \\ 0 & * & 0 \end{bmatrix},$$

$$\mathcal{W} = \begin{bmatrix} * & 0 & 0 \\ * & * & 0 \\ 0 & * & * \end{bmatrix} \quad \text{and} \quad \mathcal{H} = \begin{bmatrix} * \\ 0 \\ 0 \end{bmatrix}.$$

Therefore, we have obtained an example for structured networks with identical nodes  $(\mathcal{A}, \mathcal{B}, \mathcal{C}, \mathcal{W}, \mathcal{H})$ . ■

In this note, we say that a given structured network  $(\mathcal{A}, \mathcal{B}, \mathcal{C}, \mathcal{W}, \mathcal{H})$  is *strongly structurally controllable*, or shortly, *controllable*, if all the linear time-invariant systems  $(A, B, C, W, H) \in (\mathcal{A}, \mathcal{B}, \mathcal{C}, \mathcal{W}, \mathcal{H})$  are controllable in the classical sense [20]. The main problem in this note is stated as follows.

*Problem:* Find necessary and sufficient conditions under which the structured network  $(\mathcal{A}, \mathcal{B}, \mathcal{C}, \mathcal{W}, \mathcal{H})$  is controllable.

### III. MAIN RESULTS

In this section, we will establish several conditions for controllability of a given structured network  $(\mathcal{A}, \mathcal{B}, \mathcal{C}, \mathcal{W}, \mathcal{H})$ . First, we will provide two necessary conditions for controllability of  $(\mathcal{A}, \mathcal{B}, \mathcal{C}, \mathcal{W}, \mathcal{H})$  with respect to the structured interconnection laws  $(\mathcal{W}, \mathcal{H})$  and nodal dynamics  $(\mathcal{A}, \mathcal{B}, \mathcal{C})$ , respectively. Moreover, by introducing the concept of strong invertibility of the nodal systems  $(\mathcal{A}, \mathcal{B}, \mathcal{C})$ , a necessary and sufficient condition for controllability of the network is then established. Note that all of the above conditions are expressed as full rank conditions on pattern matrices associated with the network.

#### A. Necessary conditions for controllability of the network $(\mathcal{A}, \mathcal{B}, \mathcal{C}, \mathcal{W}, \mathcal{H})$ and their sufficiency in the SISO case

On one hand, we will elucidate a relationship between the structured interconnection laws and the controllability of the structured network, as stated in the following proposition.

*Proposition 1:* Consider a structured network  $(\mathcal{A}, \mathcal{B}, \mathcal{C}, \mathcal{W}, \mathcal{H})$ . Suppose that  $(\mathcal{A}, \mathcal{B}, \mathcal{C}, \mathcal{W}, \mathcal{H})$  is controllable. Then, we have that both the pattern matrices  $[\mathcal{W} \ \mathcal{H}]$  and  $[\bar{\mathcal{W}} \ \mathcal{H}]$  have full row rank, where  $\bar{\mathcal{W}}$  is the pattern matrix obtained from  $\mathcal{W}$  by modifying the diagonal entries of  $\mathcal{W}$  as

$$\bar{\mathcal{W}}_{ii} := \begin{cases} * & \text{if } \mathcal{W}_{ii} = 0, \\ ? & \text{otherwise.} \end{cases} \quad (7)$$

*Proof:* The proof is given in Section IV. ■

On the other hand, the dynamical behavior of the node system  $(\mathcal{A}, \mathcal{B}, \mathcal{C})$  also has a significant influence on the controllability of structured networks. Now we present another necessary condition for the controllability of the network  $(\mathcal{A}, \mathcal{B}, \mathcal{C}, \mathcal{W}, \mathcal{H})$ , based on the perspective of nodal dynamics.

*Proposition 2:* Consider a structured network  $(\mathcal{A}, \mathcal{B}, \mathcal{C}, \mathcal{W}, \mathcal{H})$ . Suppose that  $(\mathcal{A}, \mathcal{B}, \mathcal{C}, \mathcal{W}, \mathcal{H})$  is controllable. Then, we have that

both the pattern matrices  $[\mathcal{A} \ \mathcal{B}]$  and  $[\bar{\mathcal{A}} \ \mathcal{B}]$  have full row rank. Moreover, if there exist matrices  $B \in \mathcal{P}(\mathcal{B})$  and  $H \in \mathcal{P}(\mathcal{H})$  such that  $\text{rank}(H \otimes B) < N$ , then the matrices  $[\mathcal{A}^\top \ \mathcal{C}^\top]$  and  $[\bar{\mathcal{A}}^\top \ \mathcal{C}^\top]$  have full row rank.

*Proof:* The proof is given in Section IV. ■

*Remark 1:* Note that by Theorem 6 of [11], for a given network  $(\mathcal{A}, \mathcal{B}, \mathcal{C}, \mathcal{W}, \mathcal{H})$ , the full rank properties of  $[\mathcal{A} \ \mathcal{B}]$  and  $[\bar{\mathcal{A}} \ \mathcal{B}]$  mean that the nodal system  $(\mathcal{A}, \mathcal{B}, \mathcal{C})$  is controllable. Moreover, due to the duality of controllability and observability, the full rank properties of  $[\mathcal{A}^\top \ \mathcal{C}^\top]$  and  $[\bar{\mathcal{A}}^\top \ \mathcal{C}^\top]$  imply the observability of  $(\mathcal{A}, \mathcal{B}, \mathcal{C})$ . ■

After presenting necessary conditions for network controllability, a natural following question is whether these conditions are also sufficient. Actually, for structured networks with SISO nodes, these conditions are indeed sufficient as shown in the following theorem.

*Theorem 3:* Consider a structured network  $(\mathcal{A}, \mathcal{B}, \mathcal{C}, \mathcal{W}, \mathcal{H})$  with identical SISO nodes, i.e.,  $p = 1$ . Two cases are possible,

- 1) when  $\mathcal{H}$  has full row rank, the network is controllable if and only if both matrices  $[\mathcal{A} \ \mathcal{B}]$  and  $[\bar{\mathcal{A}} \ \mathcal{B}]$  have full row rank;
- 2) when  $\mathcal{H}$  does not have full row rank, the network is controllable if and only if all the matrices

$$[\mathcal{A} \ \mathcal{B}], \quad [\bar{\mathcal{A}} \ \mathcal{B}], \quad [\mathcal{A}^\top \ \mathcal{C}^\top], \quad [\bar{\mathcal{A}}^\top \ \mathcal{C}^\top],$$

$$[\mathcal{W} \ \mathcal{H}] \quad \text{and} \quad [\bar{\mathcal{W}} \ \mathcal{H}]$$

have full row rank.

*Proof:* The proof is given in Section IV. ■

Next, we will provide a counterexample to show that the conditions in Propositions 1 and 2 are *not* sufficient for controllability of structured networks with identical MIMO nodes.

*Example 2:* Consider the structured network  $(\mathcal{A}, \mathcal{B}, \mathcal{C}, \mathcal{W}, \mathcal{H})$  in which

$$\mathcal{A} = \begin{bmatrix} 0 & * \\ * & 0 \end{bmatrix}, \quad \mathcal{B} = \begin{bmatrix} * & * \\ 0 & 0 \end{bmatrix}, \quad \mathcal{C} = \begin{bmatrix} * & 0 \\ 0 & * \end{bmatrix},$$

$$\mathcal{W} = \begin{bmatrix} 0 & 0 \\ * & 0 \end{bmatrix} \quad \text{and} \quad \mathcal{H} = \begin{bmatrix} * \\ 0 \end{bmatrix}.$$

First, one can verify that all the pattern matrices  $[\mathcal{A} \ \mathcal{B}]$ ,  $[\bar{\mathcal{A}} \ \mathcal{B}]$ ,  $[\mathcal{A}^\top \ \mathcal{C}^\top]$ ,  $[\bar{\mathcal{A}}^\top \ \mathcal{C}^\top]$ ,  $[\mathcal{W} \ \mathcal{H}]$  and  $[\bar{\mathcal{W}} \ \mathcal{H}]$  have full row rank. Therefore, the conditions in Propositions 1 and 2 are satisfied.

However, we will show that the network  $(\mathcal{A}, \mathcal{B}, \mathcal{C}, \mathcal{W}, \mathcal{H})$  is not controllable. More explicitly, consider the matrices

$$A = \begin{bmatrix} 0 & 1 \\ 1 & 0 \end{bmatrix}, \quad B = \begin{bmatrix} 1 & 1 \\ 0 & 0 \end{bmatrix}, \quad C = \begin{bmatrix} 1 & 0 \\ 0 & 1 \end{bmatrix},$$

$$W = \begin{bmatrix} 0 & 0 \\ 1 & 0 \end{bmatrix} \quad \text{and} \quad H = \begin{bmatrix} 1 \\ 0 \end{bmatrix}.$$

Clearly, it holds that  $A \in \mathcal{P}(\mathcal{A}), B \in \mathcal{P}(\mathcal{B}), C \in \mathcal{P}(\mathcal{C}), W \in \mathcal{P}(\mathcal{W})$  and  $H \in \mathcal{P}(\mathcal{H})$ , which implies that the system  $(A, B, C, W, H) \in (\mathcal{A}, \mathcal{B}, \mathcal{C}, \mathcal{W}, \mathcal{H})$ . Choose a number  $\lambda = -1$ , we can verify that  $[\mathbb{I}_2 \otimes A + W \otimes BC - \lambda \mathbb{I}_4 \ \ H \otimes B]$  does not have full row rank. Hence, by the Hautus test [20],  $(A, B, C, W, H)$  is not controllable, which implies that  $(\mathcal{A}, \mathcal{B}, \mathcal{C}, \mathcal{W}, \mathcal{H})$  is not controllable. ■

#### B. Necessary and sufficient conditions in the MIMO case

In the preceding subsection, we have shown that the proposed necessary conditions for controllability of  $(\mathcal{A}, \mathcal{B}, \mathcal{C}, \mathcal{W}, \mathcal{H})$  are not sufficient for networks with MIMO nodes. In order to establish sufficient conditions in the MIMO case, we introduce the following novel property for the nodal system  $(\mathcal{A}, \mathcal{B}, \mathcal{C})$ .

*Definition 4:* For a given network  $(\mathcal{A}, \mathcal{B}, \mathcal{C}, \mathcal{W}, \mathcal{H})$ , the nodal system  $(\mathcal{A}, \mathcal{B}, \mathcal{C})$  is called *strongly invertible* if both the pattern matrices

$$\begin{bmatrix} \mathcal{A} & \mathcal{B} \\ \mathcal{C} & 0 \end{bmatrix} \quad \text{and} \quad \begin{bmatrix} \bar{\mathcal{A}} & \mathcal{B} \\ \mathcal{C} & 0 \end{bmatrix}$$

have full rank in which  $\bar{\mathcal{A}}$  is the pattern matrix obtained from  $\mathcal{A}$  by modifying the diagonal entries of  $\mathcal{A}$  as follows

$$\bar{\mathcal{A}}_{ii} := \begin{cases} * & \text{if } \mathcal{A}_{ii} = 0, \\ ? & \text{otherwise.} \end{cases} \quad (8)$$

*Remark 2:* Note that the notion of strong invertibility is relevant (but not equivalent) to the classical left/right invertibility [20] in linear control theory. More explicitly, a linear system  $(A, B, C)$  is called left/right invertible if there exists a number  $\lambda \in \mathbb{C}$  such that  $\begin{bmatrix} A - \lambda I_n & B \\ C & 0 \end{bmatrix}$  has full column/row rank. However, it will be shown in Lemma 9 below that the node system  $(\mathcal{A}, \mathcal{B}, \mathcal{C})$  is strongly invertible if and only if  $\begin{bmatrix} A - \lambda I_n & B \\ C & 0 \end{bmatrix}$  has full rank for every  $(A, B, C) \in (\mathcal{A}, \mathcal{B}, \mathcal{C})$  and for all  $\lambda \in \mathbb{C}$ . Furthermore, strong invertibility of  $(\mathcal{A}, \mathcal{B}, \mathcal{C})$  implies that the node is both controllable and observable, but the reverse statement is not true.

Next, we provide the following example to illustrate that a network with strongly invertible nodes can be made controllable via simple structured interconnection laws.

*Example 3:* Consider a structured network  $(\mathcal{A}, \mathcal{B}, \mathcal{C}, \mathcal{W}, \mathcal{H})$ , in which  $(\mathcal{A}, \mathcal{B}, \mathcal{C})$  is strongly invertible, and

$$\mathcal{W} = \begin{bmatrix} 0 & 0 \\ * & 0 \end{bmatrix} \quad \text{and} \quad \mathcal{H} = \begin{bmatrix} * \\ 0 \end{bmatrix}.$$

Clearly, the condition in Proposition 1 is satisfied, i.e., both  $[\mathcal{W} \ \mathcal{H}]$  and  $[\bar{\mathcal{W}} \ \mathcal{H}]$  have full row rank. It turns out that the network  $(\mathcal{A}, \mathcal{B}, \mathcal{C}, \mathcal{W}, \mathcal{H})$  is controllable. Indeed, by the definition of pattern class associated with the given pattern matrices, the matrices in  $\mathcal{P}(\mathcal{W})$  and  $\mathcal{P}(\mathcal{H})$  have the form

$$W = \begin{bmatrix} 0 & 0 \\ w & 0 \end{bmatrix} \quad \text{and} \quad H = \begin{bmatrix} h \\ 0 \end{bmatrix},$$

where  $w \neq 0$  and  $h \neq 0$ . Let  $(A, B, C) \in (\mathcal{A}, \mathcal{B}, \mathcal{C})$ ,  $\lambda \in \mathbb{C}$  and  $z = [z_1^* \ z_2^*]^* \in \mathbb{C}^4$  such that

$$[z_1^* \ z_2^*] \begin{bmatrix} A - \lambda I_2 & 0 & hB \\ wBC & A - \lambda I_2 & 0 \end{bmatrix} = 0.$$

Since  $h$  and  $w$  are nonzero, it follows that

$$[z_1^* \ wz_2^* B] \begin{bmatrix} A - \lambda I_2 & B \\ C & 0 \end{bmatrix} = 0.$$

By Definition 4, the strong invertibility of  $(\mathcal{A}, \mathcal{B}, \mathcal{C})$  implies that  $\begin{bmatrix} \mathcal{A} & \mathcal{B} \\ \mathcal{C} & 0 \end{bmatrix}$  and  $\begin{bmatrix} \bar{\mathcal{A}} & \mathcal{B} \\ \mathcal{C} & 0 \end{bmatrix}$  have full row rank. It then follows that  $\begin{bmatrix} A - \lambda I_2 & B \\ C & 0 \end{bmatrix}$  has full row rank. We thus have  $z_1 = z_2 B = 0$  which in turn implies that  $z_2 = 0$ . Hence the system  $(A, B, C, W, H)$  is controllable. Since the matrices  $A, B, C, W$  and  $H$  are chosen arbitrarily, the structured network  $(\mathcal{A}, \mathcal{B}, \mathcal{C}, \mathcal{W}, \mathcal{H})$  is also controllable. ■

Generally speaking, when the nodal systems are strongly invertible, the necessary condition in Proposition 1 turns out to be also sufficient for structured network controllability, as stated in the theorem below.

*Theorem 5:* Consider a structured network  $(\mathcal{A}, \mathcal{B}, \mathcal{C}, \mathcal{W}, \mathcal{H})$ . Suppose that the nodal system  $(\mathcal{A}, \mathcal{B}, \mathcal{C})$  is strongly invertible. Then, the network  $(\mathcal{A}, \mathcal{B}, \mathcal{C}, \mathcal{W}, \mathcal{H})$  is controllable if and only if both the pattern matrices  $[\mathcal{W} \ \mathcal{H}]$  and  $[\bar{\mathcal{W}} \ \mathcal{H}]$  have full row rank.

*Proof:* The proof is given in Section IV. ■

To conclude this section, we will apply graph-theoretic methods to verify the conditions in Theorem 5. To this end, we need to check the full rank property of given pattern matrices. Fortunately, the latter can be checked efficiently by [11, Theorem 10]. More explicitly, we recall some graph theoretic preliminaries from [11]. Define the directed graph associated with  $\mathcal{M} \in \{0, *, ?\}^{p \times q}$  as  $G(\mathcal{M}) = (V, E)$ . Here the node set  $V$  is given by  $V = \{1, \dots, \max(p, q)\}$  and the edge set  $E$  is defined as

$$E = \{(i, j) \in V \times V \mid \mathcal{M}_{ji} = * \text{ or } ?\}.$$

To distinguish the entries  $*$  and  $?$  in  $\mathcal{M}$ , we partition the edge set  $E$  into two disjoint subsets  $E_*$  and  $E_?$ , given by, respectively,

$$E_* = \{(i, j) \in E \mid \mathcal{M}_{ji} = *\}$$

and

$$E_? = \{(i, j) \in E \mid \mathcal{M}_{ji} = ?\}.$$

Consider the following coloring procedure which was defined in [11]:

- 1) Initially, color all nodes of  $G(\mathcal{M})$  white.
- 2) If a node  $i$  has exactly one white out-neighbor  $j$  and  $(i, j) \in E_*$ , change the color of  $j$  to black.
- 3) Repeat step 2 until no more changes are possible.

The *derived set*  $S(\mathcal{M})$  of  $G(\mathcal{M})$  is defined as the set of all black nodes obtained by applying the above procedure to  $G(\mathcal{M})$ . It has been shown in [11, Theorem 10] that  $\mathcal{M}$  has full row rank if and only if  $S(\mathcal{M}) = \{1, \dots, p\}$ .

Finally, let us revisit the network  $(\mathcal{A}, \mathcal{B}, \mathcal{C}, \mathcal{W}, \mathcal{H})$  in Example 1 and illustrate that its controllability can be checked using a graph-theoretic method.

*Example 4:* In this example, we will verify the controllability of such network by the conditions in Theorem 5 in terms of colorability of graphs associated with pattern matrices. More explicitly, consider the graphs  $G(\begin{bmatrix} \mathcal{A} & \mathcal{B} \\ \mathcal{C} & 0 \end{bmatrix})$ ,  $G(\begin{bmatrix} \bar{\mathcal{A}} & \mathcal{B} \\ \mathcal{C} & 0 \end{bmatrix})$ ,  $G([\mathcal{W} \ \mathcal{H}])$ , and  $G([\bar{\mathcal{W}} \ \mathcal{H}])$ , as depicted in Figures 2a, 3a, 4a and 5a. By applying the color change rule repeatedly as shown in Figures 2-5, one can verify that all the above graphs are colorable, which means that the matrices  $\begin{bmatrix} \mathcal{A} & \mathcal{B} \\ \mathcal{C} & 0 \end{bmatrix}$ ,  $\begin{bmatrix} \bar{\mathcal{A}} & \mathcal{B} \\ \mathcal{C} & 0 \end{bmatrix}$ ,  $[\mathcal{W} \ \mathcal{H}]$  and  $[\bar{\mathcal{W}} \ \mathcal{H}]$  have full row rank. By Theorem 5, the circuit network in Example 1 is controllable.

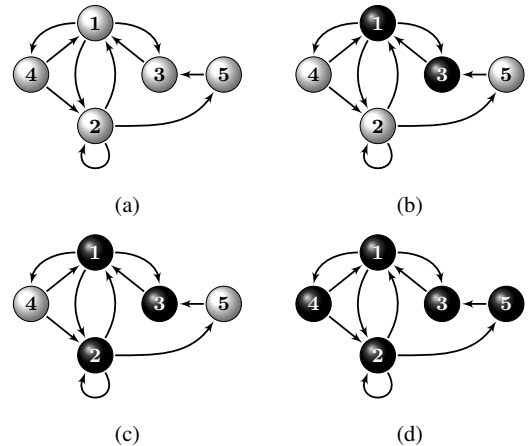
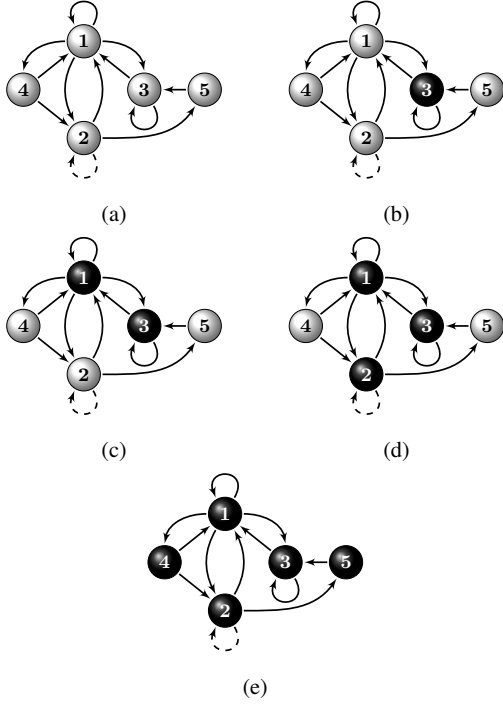
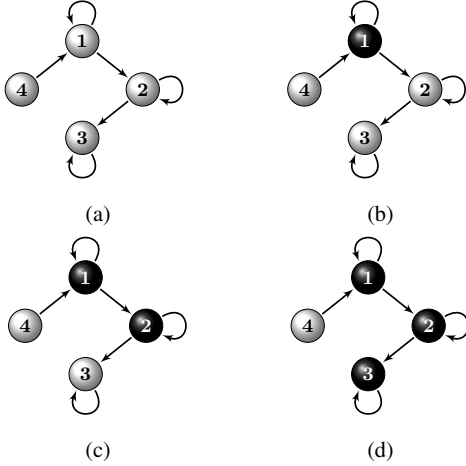
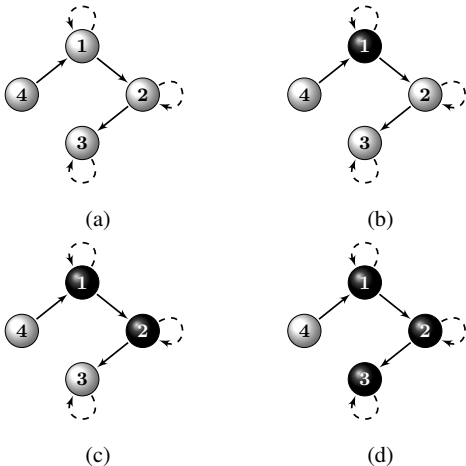

Fig. 2: The coloring procedure on  $G(\begin{bmatrix} \mathcal{A} & \mathcal{B} \\ \mathcal{C} & 0 \end{bmatrix})$ .

Fig. 3: The coloring procedure on  $G\left(\begin{bmatrix} \bar{A} & B \\ C & 0 \end{bmatrix}\right)$ .Fig. 4: The coloring procedure on  $G([\mathcal{W} \ \mathcal{H}])$ .Fig. 5: The coloring procedure on  $G([\bar{\mathcal{W}} \ \mathcal{H}])$ .

## IV. PROOFS

In this section, we will provide the proofs of the results proposed in this note. To facilitate this, we will first review the following result on the full rank properties of pattern matrices, which will serve as a foundation for the subsequent proofs.

**Proposition 6:** [11, Theorem 6] Consider two given pattern matrices  $\mathcal{A} \in \{0, *, ?\}^{n \times n}$  and  $\mathcal{B} \in \{0, *, ?\}^{n \times m}$ . Then, both the pattern matrices  $[\mathcal{A} \ \mathcal{B}]$  and  $[\bar{\mathcal{A}} \ \mathcal{B}]$  have full row rank if and only if the structured system  $(\mathcal{A}, \mathcal{B})$  is controllable.

### A. Proof of Proposition 1

*Proof:* Suppose that the network  $(\mathcal{A}, \mathcal{B}, \mathcal{C}, \mathcal{W}, \mathcal{H})$  is controllable. Assume that either the pattern matrix  $[\mathcal{W} \ \mathcal{H}]$  or  $[\bar{\mathcal{W}} \ \mathcal{H}]$  does not have full row rank. By Proposition 6 and the Hautus test, there exist matrices  $W \in \mathcal{P}(\mathcal{W})$ ,  $H \in \mathcal{P}(\mathcal{H})$  and a complex number  $\lambda \in \mathbb{C}$  such that  $[W - \lambda I_N \ H]$  does not have full row rank. This means that there exists a nonzero vector  $\xi \in \mathbb{C}^N$  such that  $\xi^* [W - \lambda I_N \ H] = 0$ . Consider matrices  $A \in \mathcal{P}(\mathcal{A})$ ,  $B \in \mathcal{P}(\mathcal{B})$ , and  $C \in \mathcal{P}(\mathcal{C})$  such that  $A + \lambda BC$  has an eigenvalue  $\beta \in \mathbb{C}$  with a nonzero eigenvector  $\zeta \in \mathbb{C}^n$ , which indicates  $\zeta^* (A + \lambda BC - \beta I_n) = 0$ . It then holds that

$$\begin{aligned} & (\xi^* \otimes \zeta^*) [I_N \otimes (A - \beta I_n) + W \otimes BC \ H \otimes B] \\ &= [\xi^* \otimes (\zeta^* (A - \beta I_n + \lambda BC)) \ (\xi^* H) \otimes (\zeta^* B)] = 0, \end{aligned}$$

which implies that  $(I_N \otimes A + W \otimes BC, H \otimes B)$  is not controllable by the Hautus test, and thus the network  $(\mathcal{A}, \mathcal{B}, \mathcal{C}, \mathcal{W}, \mathcal{H})$  is not controllable. Therefore, we reach a contradiction. ■

### B. Proof of Proposition 2

*Proof:* Suppose that  $(\mathcal{A}, \mathcal{B}, \mathcal{C}, \mathcal{W}, \mathcal{H})$  is controllable, which means that for every  $(A, B, C, W, H) \in (\mathcal{A}, \mathcal{B}, \mathcal{C}, \mathcal{W}, \mathcal{H})$  and  $\lambda \in \mathbb{C}$ , the matrix  $[I_N \otimes (A - \lambda I_n) + W \otimes BC \ H \otimes B]$  has full row rank. By Proposition 1, it follows immediately that both  $[\mathcal{W} \ \mathcal{H}]$  and  $[\bar{\mathcal{W}} \ \mathcal{H}]$  have full row rank. Next, assume that either  $[\mathcal{A} \ \mathcal{B}]$  or  $[\bar{\mathcal{A}} \ \mathcal{B}]$  does not have full row rank, which implies that there exist a pair  $(A, B) \in (\mathcal{A}, \mathcal{B})$ , a complex number  $\lambda$  and a nonzero vector  $\zeta \in \mathbb{C}^n$  such that

$$\zeta^* [A - \lambda I_n \ B] = 0.$$

Choose a nonzero vector  $\xi \in \mathbb{C}^N$  and any triple  $(C, W, H) \in \mathcal{P}(\mathcal{C}) \times \mathcal{P}(\mathcal{W}) \times \mathcal{P}(\mathcal{H})$ . It then holds that

$$(\xi^* \otimes \zeta^*) [I_N \otimes (A - \lambda I_n) + W \otimes BC \ H \otimes B] = 0,$$

which implies that  $[I_N \otimes (A - \lambda I_n) + W \otimes BC \ H \otimes B]$  does not have full row rank, and thus we reach a contradiction.

Furthermore, suppose that there exist matrices  $(B, H) \in \mathcal{P}(\mathcal{B}) \times \mathcal{P}(\mathcal{H})$  such that  $\text{rank}(H \otimes B) < N$ . We assume that either  $[\mathcal{A}^\top \ \mathcal{C}^\top]$  or  $[\bar{\mathcal{A}}^\top \ \mathcal{C}^\top]$  does not have full row rank, which implies that there exist  $(A, B) \in \mathcal{P}(\mathcal{A}) \times \mathcal{P}(\mathcal{B})$  and  $\lambda \in \mathbb{C}$  such that

$$\text{rank}([A^\top - \lambda I_n \ C^\top]) \leq n - 1.$$

Thus, we obtain that

$$\begin{aligned} & \text{rank}([I_N \otimes (A - \lambda I_n) + W \otimes BC \ H \otimes B]) \\ & \leq \text{rank}(I_N \otimes (A - \lambda I_n) + W \otimes BC) + \text{rank}(H \otimes B) \\ & \leq N \cdot \text{rank}\left(\begin{bmatrix} A - \lambda I_n \\ C \end{bmatrix}\right) + \text{rank}(H \otimes B) \\ & \leq Nn - 1. \end{aligned}$$

Hence, we reach a contradiction and complete the proof. ■

### C. Proof of Theorem 3

The proof of case 1) in Theorem 3 is trivial and is thus omitted. In addition, by Propositions 1 and 2, the ‘only if’ part of case 2) in Theorem 3 is proved immediately. Therefore, we only need to prove the ‘if’ part of case 2). To this end, we need the following lemmata.

*Lemma 7:* Consider the network  $(A, B, C, W, H)$ , given by (3), where  $A \in \mathbb{R}^{n \times n}$ ,  $B \in \mathbb{R}^{n \times p}$ ,  $C \in \mathbb{R}^{p \times n}$ ,  $W \in \mathbb{R}^{N \times N}$ ,  $H \in \mathbb{R}^{N \times m}$ . Suppose that the matrices

$$\begin{bmatrix} A - \lambda I_n & B \\ C & 0 \end{bmatrix} \quad \text{and} \quad [W - \mu I_N \quad H]$$

have full row rank for all  $\lambda \in \mathbb{C}$  and  $\mu \in \mathbb{C}$ . Then the network  $(A, B, C, W, H)$  is controllable.

*Proof:* Suppose that the matrices

$$\begin{bmatrix} A - \lambda I_n & B \\ C & 0 \end{bmatrix} \quad \text{and} \quad [W - \mu I_N \quad H]$$

have full row ranks for all  $\lambda \in \mathbb{C}$  and  $\mu \in \mathbb{C}$ . Choose a complex number  $\lambda$  and a vector  $z \in \mathbb{C}^{nN}$  such that

$$z^* [I_N \otimes (A - \lambda I_n) + W \otimes BC \quad H \otimes B] = 0. \quad (9)$$

In the following proof, we aim to prove that  $z = 0$ . To this end, we will first prove that

$$z^* [H \otimes B \quad WH \otimes B \quad \dots \quad W^{N-1}H \otimes B] = 0. \quad (10)$$

We now use mathematical induction method, first it holds that  $z^* H \otimes B = 0$ , and we then assume that

$$z^* (WH \otimes B) = \dots = z^* (W^k H) \otimes B = 0$$

with  $1 \leq k \leq N - 1$ . By right-multiplying a matrix  $\begin{bmatrix} W^k H \otimes I_n & 0 \\ 0 & I_m \otimes I_p \end{bmatrix}$  to both sides of (9), it follows that

$$\begin{aligned} & z^* [W^k H \otimes (A - \lambda I_n) + W^{k+1} H \otimes BC \quad H \otimes B] \\ &= z^* [W^k H \otimes I_n \quad W^{k+1} H \otimes B] \begin{bmatrix} I_N \otimes (A - \lambda I_n) & I_N \otimes B \\ I_N \otimes C & 0 \end{bmatrix} \\ &= 0, \end{aligned}$$

which implies that  $z^* (W^{k+1} H \otimes B) = 0$ , and thus (10) holds. Moreover, since  $[W - \mu I_N \quad H]$  being full row rank for all  $\mu \in \mathbb{C}$  implies that the matrix  $[H \quad WH \quad \dots \quad W^{N-1}H]$  has full row rank, it holds that  $z^* (I_N \otimes B) = 0$ . Thus, we have  $z^* [I_N \otimes (A - \lambda I_n) \quad I_N \otimes B] = 0$ , which implies  $z = 0$ . Therefore, by the Hautus test, it follows that the network  $(A, B, C, W, H)$  is controllable, and the proof is completed.  $\blacksquare$

*Lemma 8:* Consider a network  $(A, B, C, W, H)$  in which  $A \in \mathbb{R}^{n \times n}$ ,  $B \in \mathbb{R}^{n \times 1}$ ,  $C \in \mathbb{R}^{1 \times n}$ ,  $W \in \mathbb{R}^{N \times N}$  and  $H \in \mathbb{R}^{N \times m}$ . Suppose that the system  $(A, B, C)$  is controllable and observable, and  $[W - \mu I_N \quad H]$  has full row rank for all  $\mu \in \mathbb{C}$ . Then the network  $(A, B, C, W, H)$  is controllable. <sup>3</sup>

*Proof:* Suppose that the system  $(A, B, C)$  is controllable and observable, and  $[W - \mu I_N \quad H]$  has full row rank for all  $\mu \in \mathbb{C}$ . It follows that for all  $\lambda \in \mathbb{C}$ , the matrices

$$[A - \lambda I_n \quad B] \quad \text{and} \quad [A^\top - \lambda I_n \quad C^\top] \quad (11)$$

have full row rank. Let  $(\lambda, z) \in \mathbb{C} \times \mathbb{C}^{Nn}$  such that

$$z^* [I_N \otimes (A - \lambda I_n) + W \otimes BC \quad H \otimes B] = 0. \quad (12)$$

We then prove that  $z = 0$ . To do so, we distinguish two cases: a)  $\lambda \in \sigma(A)$  and b)  $\lambda \notin \sigma(A)$ , where  $\sigma(A)$  denotes the spectrum of  $A$ . In

<sup>3</sup>In Corollary 10 of [1], similar conditions for homogeneous networks with SISO nodes have already been presented, along with a proof using the behavioral approach. We offer an alternative proof utilizing the Hautus test.

case a), the matrix  $A - \lambda I_n$  is singular, and  $B$  and  $C$  are independent of the columns and rows in  $A - \lambda I_n$ , respectively. Therefore, the matrix  $\begin{bmatrix} A - \lambda I_n & B \\ C & 0 \end{bmatrix}$  has full rank. By Lemma 7, it follows that the matrix  $[I_N \otimes (A - \lambda I_n) + W \otimes BC \quad H \otimes B]$  has full row rank, and thus  $z = 0$ . In case b), the matrix  $A - \lambda I_n$  is nonsingular, by right-multiplying the matrix  $\begin{bmatrix} I_N \otimes (A - \lambda I_n)^{-1} B & 0 \\ 0 & I_N \end{bmatrix}$  to the both sides of (12), we obtain that

$$z^* [I_N \otimes B + W \otimes \delta B \quad H \otimes B] = 0, \quad (13)$$

where  $\delta = C(A - \lambda I_n)^{-1}B$ . We then distinguish two cases: 1)  $\delta = 0$ , and 2)  $\delta \neq 0$ . We will show that in both cases  $z^* [I_N \otimes (A - \lambda I_n) \quad I_N \otimes B] = 0$ , and thus  $z = 0$ . In case 1), we have  $z^* (I_N \otimes B) = 0$ , and thus  $z^* [I_N \otimes (A - \lambda I_n) \quad I_N \otimes B] = 0$ . Since  $[A - \lambda I \quad B]$  has full row rank, we have  $z = 0$ . In case 2), by (13), we have  $z^* ([W + \frac{1}{\delta} I \quad H] \otimes B) = 0$ . Since  $[W - \mu I_N \quad H]$  has full row rank for all  $\mu \in \mathbb{C}$ , it follows that  $z^* (I_N \otimes B) = 0$ , and thus  $z^* [I_N \otimes (A - \lambda I_n) \quad I_N \otimes B] = 0$ . Therefore, we have proved  $z = 0$ , which implies that  $(A, B, C, W, H)$  is controllable, and the proof is completed.  $\blacksquare$

We are now ready to prove the ‘if’ part of case 2) in Theorem 3.

*Proof:* Suppose that all the matrices

$$\begin{aligned} & [A \quad B], [\bar{A} \quad \bar{B}], [A^\top \quad C^\top], [\bar{A}^\top \quad \bar{C}^\top], \\ & [W \quad \mathcal{H}] \quad \text{and} \quad [\bar{W} \quad \bar{\mathcal{H}}] \end{aligned}$$

have full row rank. By Proposition 6 and the duality of observability and controllability, we have that for every  $(A, B, C, W, H) \in (\mathcal{A}, \mathcal{B}, \mathcal{C}, \mathcal{W}, \mathcal{H})$ , the system  $(A, B, C)$  is controllable and observable, and  $[W - \mu I_N \quad H]$  has full row rank for all  $\mu \in \mathbb{C}$ . By Lemma 8, we have that the network  $(A, B, C, W, H)$  is controllable. Therefore, the structured network  $(\mathcal{A}, \mathcal{B}, \mathcal{C}, \mathcal{W}, \mathcal{H})$  is controllable, and we complete the proof.  $\blacksquare$

### D. Proof of Theorem 5

Before proving of Theorem 5, we need the following result.

*Lemma 9:* Consider a structured node system  $(\mathcal{A}, \mathcal{B}, \mathcal{C})$  with  $\mathcal{A} \in \{0, *, ?\}^{n \times n}$ ,  $\mathcal{B} \in \{0, *, ?\}^{n \times p}$  and  $\mathcal{C} \in \{0, *, ?\}^{p \times n}$ . Then,  $(\mathcal{A}, \mathcal{B}, \mathcal{C})$  is strongly invertible if and only if the matrix  $\begin{bmatrix} A - \lambda I_n & B \\ C & 0 \end{bmatrix}$  has full rank for every  $(A, B, C) \in (\mathcal{A}, \mathcal{B}, \mathcal{C})$  and for all  $\lambda \in \mathbb{C}$ .

*Proof:* We omit the proof since it follows a similar line as that of [11, Theorem 6].  $\blacksquare$

It is now ready to provide the proof of Theorem 5.

*Proof:* Since the ‘only if’ part follows immediately from Proposition 1, we only need to prove the ‘if’ part. Suppose that both  $[W \quad \mathcal{H}]$  and  $[\bar{W} \quad \bar{\mathcal{H}}]$  have full row rank. By Proposition 6 and the Kalman rank test, it holds that the matrix  $[H \quad WH \quad \dots \quad W^{N-1}H]$  has full row rank. Let  $(A, B, C, W, H) \in (\mathcal{A}, \mathcal{B}, \mathcal{C}, \mathcal{W}, \mathcal{H})$ . Since the node system  $(\mathcal{A}, \mathcal{B}, \mathcal{C})$  is strongly invertible, i.e., both the pattern matrices

$$\begin{bmatrix} \mathcal{A} & \mathcal{B} \\ \mathcal{C} & 0 \end{bmatrix} \quad \text{and} \quad \begin{bmatrix} \bar{\mathcal{A}} & \bar{\mathcal{B}} \\ \bar{\mathcal{C}} & 0 \end{bmatrix}$$

have full row rank, by Lemma 9 we have that the matrix

$$\begin{bmatrix} A - \lambda I_n & B \\ C & 0 \end{bmatrix}$$

has full row rank for all  $\lambda \in \mathbb{C}$ . Moreover, by Lemma 7, we have that the network  $(A, B, C, W, H)$  is controllable. Since the matrices  $(A, B, C, W, H)$  are chosen from  $(\mathcal{A}, \mathcal{B}, \mathcal{C}, \mathcal{W}, \mathcal{H})$  arbitrarily, the structured network  $(\mathcal{A}, \mathcal{B}, \mathcal{C}, \mathcal{W}, \mathcal{H})$  is controllable, and thus we have completed the proof.  $\blacksquare$

## V. CONCLUSIONS AND DISCUSSIONS

In this note, we have focused on the strong structural controllability issue for structured networks with identical nodes denoted by  $(\mathcal{A}, \mathcal{B}, \mathcal{C}, \mathcal{W}, \mathcal{H})$ . Firstly, we have constructed a general form of structured networks with identical nodes, illustrated by a network of electrical circuits. Secondly, two necessary conditions for controllability have been established. It has been shown that these conditions are only sufficient for networks with SISO nodes, but not for those with MIMO nodes. Thirdly, a novel notion named strong invertibility of node systems has been introduced. By assuming node systems being strongly invertible, we have proposed a necessary and sufficient condition for controllability of networks with MIMO nodes. Finally, by adopting a recently proposed color change rule on graphs, we have checked the controllability of the network of electrical circuits to demonstrate the effectiveness of our results.

Note that while the nodal systems satisfying strong invertibility can render the condition in Theorem 5 necessary and sufficient for achieving controllability of the network, it is not a prerequisite for the structured network to be controllable, as illustrated by the following counterexample.

*Example 5:* Consider a network  $(\mathcal{A}, \mathcal{B}, \mathcal{C}, \mathcal{W}, \mathcal{H})$ , where

$$\mathcal{A} = \begin{bmatrix} 0 & * \\ * & 0 \end{bmatrix}, \mathcal{B} = \mathcal{C}^\top = \begin{bmatrix} * \\ 0 \end{bmatrix}, \mathcal{W} = \begin{bmatrix} 0 & 0 \\ * & 0 \end{bmatrix} \text{ and } \mathcal{H} = \begin{bmatrix} * \\ 0 \end{bmatrix}.$$

One can verify that the matrix

$$\begin{bmatrix} \mathcal{A} & \mathcal{B} \\ \mathcal{C} & 0 \end{bmatrix} = \begin{bmatrix} 0 & * & * \\ * & 0 & 0 \\ * & 0 & 0 \end{bmatrix}$$

does not have full row rank. However, it turns out that the network  $(\mathcal{A}, \mathcal{B}, \mathcal{C}, \mathcal{W}, \mathcal{H})$  is controllable. Indeed, consider the matrices

$$A = \begin{bmatrix} 0 & c_1 \\ c_2 & 0 \end{bmatrix}, \quad B = \begin{bmatrix} c_3 \\ 0 \end{bmatrix}, \quad C = [c_4 \quad 0], \\ W = \begin{bmatrix} 0 & 0 \\ c_5 & 0 \end{bmatrix} \quad \text{and} \quad H = \begin{bmatrix} c_6 \\ 0 \end{bmatrix},$$

where  $c_i \in \mathbb{R} \setminus \{0\}$  with  $i = 1, \dots, 6$ . It follows that the system  $(A, B, C, W, H)$  is controllable because the determinant of its controllability matrix  $\det([\hat{B} \quad \hat{A}\hat{B} \quad \hat{A}^2\hat{B} \quad \hat{A}^3\hat{B}])$  is nonzero for all choices of  $c_i$  with  $i = 1, \dots, 6$ , where  $\hat{A} = I_N \otimes A + W \otimes BC$  and  $\hat{B} = H \otimes B$ . Since the matrices  $A, B, C, W, H$  are chosen arbitrarily, we have that the structured network  $(\mathcal{A}, \mathcal{B}, \mathcal{C}, \mathcal{W}, \mathcal{H})$  is controllable, and thus we found a counterexample. ■

We conclude this section by presenting several potential directions for future research. Based on the above discussion, a natural direction is to explore necessary and sufficient conditions for checking network controllability without the strong invertibility assumption. Given that the structured networks studied in this note are constrained to having identical nodes, a further exploration involves extending these findings to structured networks with heterogeneous nodes [21], [22]. Last but not least, one can explore other structural properties of networks, such as input-state observability [23], output controllability [24], and fault detection and isolation [25], within the context of structured networks with identical nodes.

## REFERENCES

[1] J. Trumpp and H. L. Trentelman, "Controllability and stabilizability of networks of linear systems," *IEEE Transactions on Automatic Control*, vol. 64, no. 8, pp. 3391–3398, 2018.  
 [2] Y. Hao, Z. Duan, G. Chen, and F. Wu, "New controllability conditions for networked, identical LTI systems," *IEEE Transactions on Automatic Control*, vol. 64, no. 10, pp. 4223–4228, 2019.

[3] L. Xiang, F. Chen, W. Ren, and G. Chen, "Advances in network controllability," *IEEE Circuits and Systems Magazine*, vol. 19, no. 2, pp. 8–32, 2019.  
 [4] Z. Ji, H. Lin, and H. Yu, "Protocols design and uncontrollable topologies construction for multi-agent networks," *IEEE Transactions on Automatic Control*, vol. 60, no. 3, pp. 781–786, 2014.  
 [5] J.-M. Dion, C. Commault, and J. van der Woude, "Generic properties and control of linear structured systems: A survey," *Automatica*, vol. 39, no. 7, pp. 1125–1144, 2003.  
 [6] R. Guilherme, A. A. Pedro, and S. Pequito, "An overview of structural systems theory," *Automatica*, vol. 140, p. 110229, 2022.  
 [7] Y. Liu, J.-J. Slotine, and A.-L. Barabási, "Controllability of complex networks," *Nature*, vol. 473, no. 7346, pp. 167–173, 2011.  
 [8] N. Monshizadeh, S. Zhang, and M. K. Camlibel, "Zero forcing sets and controllability of dynamical systems defined on graphs," *IEEE Transactions on Automatic Control*, vol. 59, no. 9, pp. 2562–2567, 2014.  
 [9] A. Chapman and M. Mesbahi, "On strong structural controllability of networked systems: A constrained matching approach," in *American Control Conference*. IEEE, 2013, pp. 6126–6131.  
 [10] S. S. Mousavi, M. Haeri, and M. Mesbahi, "On the structural and strong structural controllability of undirected networks," *IEEE Transactions on Automatic Control*, vol. 63, no. 7, pp. 2234–2241, 2017.  
 [11] J. Jia, H. J. van Waarde, H. L. Trentelman, and M. K. Camlibel, "A unifying framework for strong structural controllability," *IEEE Transactions on Automatic Control*, vol. 66, no. 1, pp. 391–398, 2020.  
 [12] N. Popli, S. Pequito, S. Kar, A. P. Aguiar, and M. Ilić, "Selective strong structural minimum-cost resilient co-design for regular descriptor linear systems," *Automatica*, vol. 102, pp. 80–85, 2019.  
 [13] J. Jia, B. M. Shali, H. J. van Waarde, M. K. Camlibel, and H. L. Trentelman, "Scalable controllability analysis of structured networks," *IEEE Transactions on Control of Network Systems*, vol. 9, no. 2, pp. 891–903, 2022.  
 [14] C. Commault, "Structural controllability of networks with dynamical structured nodes," *IEEE Transactions on Automatic Control*, vol. 65, no. 6, pp. 2736–2742, 2019.  
 [15] C. Lin, "Structural controllability," *IEEE Transactions on Automatic Control*, vol. 19, no. 3, pp. 201–208, 1974.  
 [16] H. Mayeda and T. Yamada, "Strong structural controllability," *SIAM Journal on Control and Optimization*, vol. 17, no. 1, pp. 123–138, 1979.  
 [17] N. J. Cowan, E. J. Chastain, D. A. Vilhena, J. S. Freudenberg, and C. T. Bergstrom, "Nodal dynamics, not degree distributions, determine the structural controllability of complex networks," *PLoS one*, vol. 7, no. 6, p. e38398, 2012.  
 [18] C. Commault and A. Kibangou, "Generic controllability of networks with identical SISO dynamical nodes," *IEEE Transactions on Control of Network Systems*, vol. 7, no. 2, pp. 855–865, 2019.  
 [19] B. M. Shali, H. J. van Waarde, M. K. Camlibel, and H. L. Trentelman, "Properties of pattern matrices with applications to structured systems," *IEEE Control Systems Letters*, vol. 6, no. 8, pp. 109–114, 2021.  
 [20] H. L. Trentelman, A. A. Stoorvogel, and M. L. J. Hautus, *Control Theory for Linear Systems*. Springer-Verlag, 2001.  
 [21] Y. Ni, X. Lou, J. Jiao, and J. Jia, "Strong structural controllability of structured networks with MIMO node systems," *arXiv preprint arXiv:2305.10747*, 2023.  
 [22] S. S. Mousavi, A. Kouvelas, and K. H. Johansson, "Modal strong structural controllability for networks with dynamical nodes," *arXiv preprint arXiv:2108.12171*, 2021.  
 [23] S. Gracy, F. Garin, and A. Y. Kibangou, "Structural and strongly structural input and state observability of linear network systems," *IEEE Transactions on Control of Network Systems*, vol. 5, no. 4, pp. 2062–2072, 2018.  
 [24] H. J. van Waarde, M. K. Camlibel, and H. L. Trentelman, "A distance-based approach to strong target control of dynamical networks," *IEEE Transactions on Automatic Control*, vol. 62, no. 12, pp. 6266–6277, 2017.  
 [25] J. Jia, H. L. Trentelman, and M. K. Camlibel, "Fault detection and isolation for linear structured systems," *IEEE Control Systems Letters*, vol. 4, no. 4, 2020.