



HAL
open science

Multi-target synthesis of logic controllers using a MDE approach

Gérard Nzebop Ndenoka, Maurice Tchunte, Emmanuel Simeu, Valery Monthe

► **To cite this version:**

Gérard Nzebop Ndenoka, Maurice Tchunte, Emmanuel Simeu, Valery Monthe. Multi-target synthesis of logic controllers using a MDE approach. 2024. hal-04663327v1

HAL Id: hal-04663327

<https://hal.science/hal-04663327v1>

Preprint submitted on 27 Jul 2024 (v1), last revised 14 Sep 2024 (v2)

HAL is a multi-disciplinary open access archive for the deposit and dissemination of scientific research documents, whether they are published or not. The documents may come from teaching and research institutions in France or abroad, or from public or private research centers.

L'archive ouverte pluridisciplinaire **HAL**, est destinée au dépôt et à la diffusion de documents scientifiques de niveau recherche, publiés ou non, émanant des établissements d'enseignement et de recherche français ou étrangers, des laboratoires publics ou privés.



Distributed under a Creative Commons Attribution 4.0 International License

Multi-target synthesis of logic controllers

using a MDE approach

G. NZEBOP NDENOKA ^{a,d,e} — M. TCHUENTE ^{b,d,e} — E. SIMEU ^{c,d},
V. MONTHÉ ^b

^a Department of Land Surveying, National Advanced School of Public Works, P.O. Box 510 Yaoundé, Cameroon, ndenokag@yahoo.fr

^b Department of Computer Science, University of Yaoundé I, Yaoundé, Cameroon, P.O. Box 337 Yaoundé, {maurice.tchuenté, valery.monthe}@gmail.com

^c University Grenoble Alpes, CNRS, Grenoble INP*, TIMA, 38000 Grenoble, France, *Institute of Engineering Univ. Grenoble Alpes, emmanuel.simeu@imag.fr

^d University of Yaoundé I, LIRIMA Laboratory, IDASCO Team, Cameroun

^e Sorbonne Universities, UPMC Univ. Paris 06, IRD, Unité de Modélisation Mathématique et Informatique des Systèmes Complexes (UMMISCO), F-93143, Bondy, France.

.....
RÉSUMÉ. Le Grafcet est un puissant langage de modélisation graphique pour la spécification de contrôleurs dans des systèmes à événements discrets. Il prend en compte des structures hiérarchiques ainsi que des contraintes structurelles et sémantiques. Ici, nous proposons d'utiliser un modèle de spécification Grafcet dans une approche d'ingénierie dirigée par les modèles (IDM) pour la synthèse multi-cible de systèmes de contrôle commande embarqués basés sur des microcontrôleurs. Dans cette approche, un métamodèle Grafcet est associé à un métamodèle microcontrôleur, lequel caractérise les fonctionnalités de la plateforme spécifique microcontrôleur à considérer lors de la génération de code. Ce métamodèle Grafcet proposé prend en compte la modélisation des expressions pour faciliter la vérification du modèle et une interprétation facile des événements Grafcet ainsi que des contraintes de temps. Les règles de transformation utiles à la génération de code pour des microcontrôleurs C-programmables sont ensuite présentées. Comme application, nous présentons une plateforme basée sur Eclipse EMF, Object Constraint Language (OCL) et le moteur de génération de code Acceleo.

ABSTRACT. Grafcet is a powerful graphical modeling language for the specification of controllers in discrete event systems. It considers hierarchical structures as well as structural and semantic constraints. In this paper, we propose to use a Grafcet specification model in a Model Driven Engineering (MDE) approach for multi-target synthesis of embedded logic control systems based on microcontrollers. In this approach, a Grafcet metamodel is associated with a microcontroller metamodel which characterizes the microcontroller platform features to be considered when generating code. The Grafcet metamodel includes the modeling of expressions to facilitate model verification and an easy interpretation of Grafcet events and time constraints. Transformation rules for generation of C-programmable microcontroller code are then presented. As application, we present a platform based on Eclipse EMF, Object Constraint Language (OCL) and Acceleo code generation engine.

MOTS-CLÉS : synthèse multi-cibles, contrôleurs logiques, Grafcet, Ingénierie Dirigée par les Modèles, vérification de modèle, génération de code C

KEYWORDS : Multi-target synthesis, logic controllers, Grafcet, Model Driven Engineering, model verification, C code generation

.....

1. Introduction

The design cost of automated systems is greatly influenced by the time needed for the development of reliable control code [2]. This task is generally accomplished by direct implementation from the functional design specification of the controller. Conventional manual translation of the requirements of the control software into a control code often leads to additional costs caused by erroneous interpretations [2, 3]. It is therefore of great interest to automatically generate software code on the basis of a graphical specification language [4] such as Grafset that is an international standard (IEC 60848 [7]) since 1988. Indeed, it is an advantageous graphical modeling language for industrial programmable logic controller (PLC) specification in discrete event systems (DES) [4].

A lot of work has been done to make Grafset a programming language. One of the well-known developments [8] has led to the definition of Sequential Function Chart (SFC), which is one of the five languages of the IEC 61131-3 standard dedicated to the programming of PLCs. On the other hand, some authors have been interested in code generation for controllers specified in Grafset. For instance, J. Machado et al. [1] presented a safe controller design methodology permitting to easily generate control code for logic controllers taking as input a Grafset specification model. Their proposal uses Grafset algebraic equations as a formal representation of Grafset.

The continuous development of information and communication technology (ICT) has facilitated the emergence and rapid proliferation of a wide variety of low-cost processors for the execution of programs in complex embedded applications [9]. Thus, the use of programmable controllers based on microprocessors may be preferred in low cost applications to reduce the cost of the control solution. As a consequence, it is important to consider the description of the target architecture when generating code for a system specified in Grafset. This allows to handle the generation of control code for a family of hardware architectures, with the possibility to choose one specific architecture as input of the generation process.

Among the existing approaches for code generation from formal models, recent advances in the field of Model Driven Engineering (MDE) produce the most promising outcomes [2]. MDE is an expanding paradigm in the software engineering domain that promotes the use of models and model transformations for the production of software artifacts (documentation, code, etc.), with the use of Domain Specific Languages (DSLs). The MDE approach was found to be appropriate for Grafset implementation [2, 4]. Indeed, the Grafset language can be seen as a DSL and can benefit from the advances of MDE to facilitate control engineers practices, by enabling the automatic transformation of Grafset models into control code.

Whatever is the nature of the model used to represent Grafset in the code generation process, this model must support the verifications that ensure compliance with the standard [1]. A step towards a general formal definition of Grafset is proposed in [3] and can be used as a basis for Grafset model-driven development [2], including hierarchical structures [5] to enable the expansion of the existing solutions to other issues of formal methods in control system engineering. Our objective in this paper is to propose a Grafset metamodel representing all its basic concepts including events and time constraints. We will then show how to perform multi-target code generation, considering the specification of the target used.

The rest of the paper is organized as follows: section 2 presents a background on Grafset specification language and model driven development and analysis of MDE work for

Grafcet implementation. Grafcet metamodeling, verification rules and the derived properties are presented in section 3. In section 4, we present a multi target code generation, including the microcontroller metamodel while section 5 is devoted to a case study. The paper is concluded in section 6.

2. Background

The specification of the logic controller is the first step in the development of embedded controllers for a custom application [11]. Grafcet is one of commonly used formal techniques for logic controller specification. In this section, we present an overview of the Grafcet language and the MDE, which is the approach through which we formalize the Grafcet multi-target synthesis.

2.1. Grafcet description language

Grafcet is a graphical language for modeling automation systems defined in the IEC 60848 standard [7]. It is used for high level behavioral description of logic sequential systems and has been inspired from the Petri Net language [11]. Grafcet language is used for the specification, modelling and simulation of logic control systems in interaction with physical processes. A Grafcet describes the states of a system and associated actions that permit to take into account inputs and generate the corresponding outputs. This language is defined statically by its syntax and dynamically by its evolution rules.

2.1.1. Grafcet statics

A Grafcet model (as presented in Figure 1) is a directed graph with two types of nodes: steps and transitions. Steps are represented by squares while transitions are represented by horizontal lines.

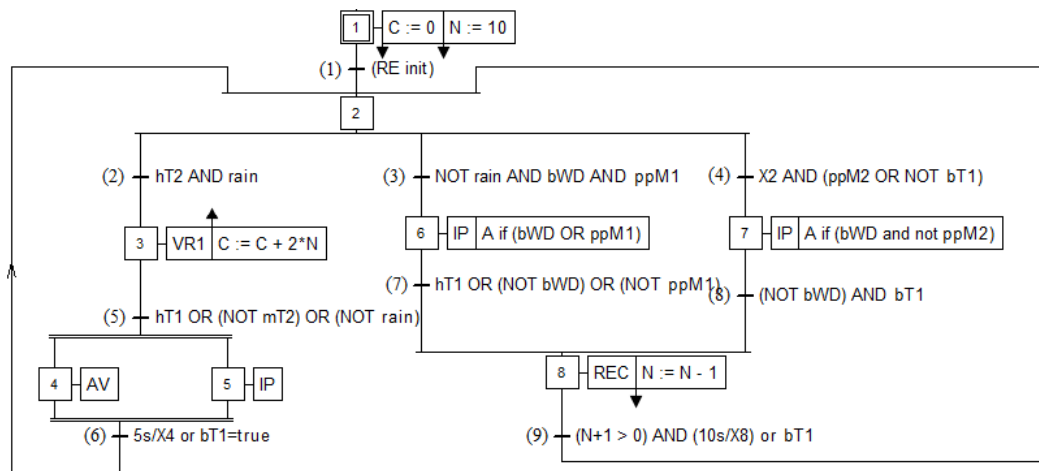

Figure 1. Example of Grafcet

Initial steps are represented with double lines. Steps are numbered or named while transitions do not need to be numbered. Steps and transitions are interconnected by directed arcs so-called junctions or connections. Those arcs necessary connect steps to transi-

tions and transitions to steps. A transition condition also called receptivity or condition is associated to each transition.

2.1.2. Grafcet dynamic behavior

The Grafcet dynamic behavior can be compared to a sequential machine that provides an event-driven conversion of an input sequence into a set of outputs, considering the controller's internal state [1, 11]. The Grafcet evolution is possible by firing (or clearing) transitions according to five evolution rules defined by the IEC 60848 standard [7] which aims to ensure a deterministic behavior :

- **Rule 1:** At the initial time, all the initial steps are active; all the other steps are inactive.

- **Rule 2:** A transition is enabled when all the steps that immediately precede this transition are active. A transition is fireable when it is enabled and when the associated transition condition is true. A fireable transition must be immediately fired.

- **Rule 3:** Firing a transition provokes simultaneously the activation of all the immediately succeeding steps and the deactivation of all the immediately preceding steps.

- **Rule 4:** When several transitions are simultaneously fireable, they are simultaneously fired.

- **Rule 5:** When a step shall be both activated and deactivated, by applying the previous evolution rules, it is activated if it was inactive, or remains active if it was previously active.

These rules enable the calculation of the subsequent state and the corresponding output signals caused by an input event [7, 11, 2]. A step defines a partial state of the system and can be active or inactive; hence, a Boolean variable X_i , named step activity variable is defined for each step. The variable X_i is true (1) if the step i is active and false (0) if not. The general state of a Grafcet called its situation, is characterized by the set of all the active steps at a given time. It can be represented by a vector $X = (X_i)$. Initial steps represented by double squares are initially activated (*Rule 1*). As soon as time passes and events occur, the continuous changing of the grafcet situation characterizes the evolution of the system that it models. A mathematical formalisation of these dynamics is proposed by [3] and R. Mros et al. [6].

2.1.3. Grafcet example

Figure 1 shows an example of a Grafcet model used in [10], inspired from a model presented in [9] to model the water supply subsystem of a tank. This model has eight steps numbered from 1 to 8 among which the step 1 is initial, nine transitions numbered from (1) to (9) and several actions among which : $C := 0$ and $N := 10$ are stored actions performed during the deactivation of step 1; $VR1$, AV and REC are continuous level actions associated respectively to steps 3, 4 and 8. The action A if (bWD OR $ppM1$) is a conditional level action. It is performed if the step 6 is active and the condition bWD OR $ppM1$ is true. The receptivity of transition (2) is $hT2$ AND $rain$. It expresses the fact that when the step 2 is activated and the value of $hT2$ AND $rain$ is *true*, this transition is fireable and should be fired; when it is fired, step 2 is deactivated and step 3 is activated. Here, $hT2$ and $rain$ are two Boolean variables modeling digital input signals.

2.2. Model driven engineering

Model Driven Engineering (MDE) is the field of software engineering that makes use of models and model transformation to produce software artifacts such as code and documentation [12].

2.2.1. Key principles and MDE approaches

The basic principle of MDE is “*everything is a model*” [12, 15]. A model is a representation of a system under study. MDE principles state that a particular view of a system can be captured by a model and each model is written in the language of its metamodel. In other words, “a metamodel is a model of models” that defines the structure of a modeling language [12]. As a consequence, a model should satisfy the structure defined at the level of its metamodel. A modeling language is a set of all possible models that are conforming to the modeling language’s abstract syntax, represented by one or more concrete syntaxes and satisfying a given semantics [12]. The process of defining a modeling language starts with the identification of the concepts, abstractions and relations underlying the application domain. It corresponds to the domain analysis phase of the development of a Domain Specific (Modeling) Language (DS(M)L).

MDE approaches are usually supported by complex tools called “model driven Meta-Tools” and commonly known as “language workbenches” [13]. They provide a collection of features to help users define DS(M)Ls, with specific editors, model validation and model transformation. Examples of such tools are Eclipse EMF, Microsoft Software Factories, and JetBrains MPS [12]. A model transformation is “the process of converting one model to another model of the same system”. Model transformation program takes as input a model conforming to a given source metamodel and produces as output another model conforming to a target metamodel [13].

2.2.2. Related work

Many PLC environments such as CoDeSys allow multi-target synthesis of logic control systems [3], but these environments are proprietary and they are not interested by the synthesis on microcontroller targets. Y. Qamsane et al [14] proposed a Grafcet metamodel for the transformation of Distributed Control model of automated manufacturing systems into Grafcet models to facilitate its implementation. This model represents the very basic Grafcet structure, but is limited to allow the construction of any Grafcet model. For example, only one action can be associated to a step, and its type (continuous or stored) is not taken into consideration. Similarly, to demonstrate that composing transformations is a complex problem, F. Basciani et al. [15] proposed a Grafcet metamodel to illustrate model transformations between incompatible metamodels, with an illustration on the transformations between Grafcet and Petri nets. This Grafcet metamodel conforms to the Grafcet standard and represents only the concepts of the most basic structure of the language. Similarly, R. Julius et al. [5] proposed a metamodel based approach for GRAFCET specifications, with a particular focus on hierarchical structures, enabling how to expand the existing solutions to other issues of formal methods in control system engineering. The variable and timing condition concept is presented, discussed and formalized by G. Nzebop N. et al. [10]. Their proposal integrates a parser capable of directly analysing and generating Grafcet expressions in an IDM environment for editing Grafcet models. However, this solution had not yet been integrated into a general Grafcet metamodel. Recently, R. Mros et al. [6] proposed a Grafcet metamodel for editing models and transforming them into Guarded Action Language (GAL) for verification purposes. Their contribution emphasizes the hierarchical structures of Grafcet and rules for editing valid Grafcet models.

Also, the Grafcet expressions must be transformed into GAL before being verified and validated. Another limitation of this IDM synthesis solution is that their target is mainly programmable controllers (via the Structured Text, one of the PLC languages [8]) and does not take into account specific targets such as microcontrollers.

Here we propose a metamodel that allows the editing of valid Grafcet models with well-constructed and verified expressions[10, 6] based on a Grafcet expression parser and the OCL language, associated with a metamodel of C-programmed microcontrollers [17] to facilitate code synthesis for these architectures.

3. Grafcet concepts and metamodel

Here, we present the Grafcet metamodeling, consisting of the identification of Grafcet concepts with their interrelations, and their formalization within a metamodel.

3.1. Grafcet concepts identification

Given the complexity of the Grafcet domain, we distinguish the identification of concepts of the basic Grafcet structure, concepts related to variables and actions, Grafcet expressions concepts and timing variables concepts.

3.1.1. Concepts of the basic Grafcet structure

With regard to the description of the Grafcet language according to the IEC 60848 2nd Ed. standard [7], it appears that a Grafcet model groups together several steps and transitions. They are linked together by oriented links also called connections. The steps (Step concept), the transitions (Transition), oriented links (*Connection*) and variables (*Variable*) are Grafcet elements (*G7Element*). Two types of connections can easily be identified: transition-to-step connections (*TransitionToStep*) and step-to-transition connections (*StepToTransition*). Each instance of *TransitionToStep* is outgoing from a transition and incoming from a step, while each instance of *StepToTransition* is outgoing a step and incoming a transition.

3.1.2. Concepts related to variables, actions and expressions

A Boolean variable (*BooleanVariable*) is associated with a step to represent its activity, and is internal to the Grafcet. Any variable (*Variable*) is either input, output or internal. It is characterized by a name and a duration of its activity. Several actions (*Action*) may be associated with a step. Every action is represented and performed by its variable. This way of structuring Action and Variable concepts makes it possible to have the same action associated with several different steps as stated in the standard. An action can only be stored (*StoredAction*) or level (*LevelAction*).

The concept *Expression* do not appear explicitly in the Grafcet standard, but it exists and its modeling permits to solve certain issues such as verifications and the providing of appropriate semantics. This concept is presented, discussed and formalized by G. Nzebop N. et al. [10], including Grafcet events and timing variables. In [6], the authors also identify the notion of *Variable* as a key concept, and use the concept *Condition* to refer to Boolean expressions (*Expression*).

3.2. The Grafcet metamodel

The formalization of Grafcet concepts and the links between them produces the Grafcet metamodel of Figure 2, which has been implemented within EMF.

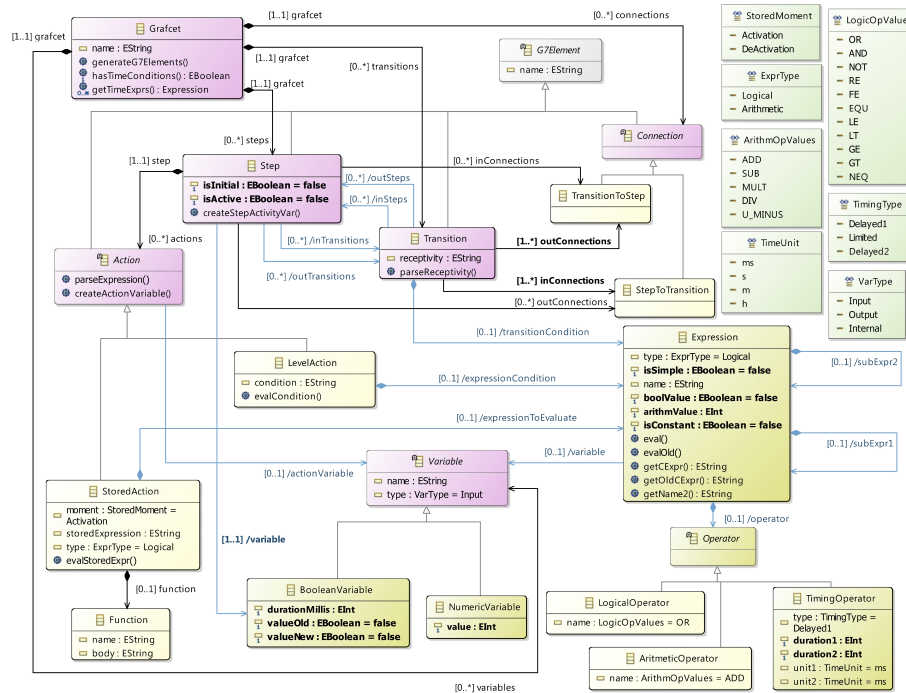

Figure 2. The Grafcet metamodel

Many relationships are automatically derived. An automatic solution for the construction of Grafcet expressions has been presented in [10], based on an ANTLR parser generator tool, called *G7Expr*, that is called to automatically and recursively derive all the elements linked to the construction of Grafcet expressions. We therefore integrate this solution into the proposed Grafcet metamodel.

To make sure that the models built are valid, semantic constraints or rules are stated, formalized with OCL (in the same way as [6] and [10]) and integrated to the Grafcet metamodel. In effect, OCL is a formal language that is independent of a programming language [6]. It is used to describe elements on UML models and to query metamodel instances. Generally, OCL expressions are written in the context of a specific instance of a model, to which the keyword *self* refers. The “.” operator refers to an attribute, resulting to a single attribute or a set, called collection; while the “->” operator refers to the navigation from a collection.

For example, the constraint “A Grafcet has at least one initial step” is formalized with OCL as follows :

Listing 1: A Grafcet has at least one initial step

```
context Grafcet invariant hasAtLeastOneInitialStep :
    self.steps->select(s|s.isInitial)->size()>=1;
```

Annex 1 contains other rules that have been clearly identified, stated and formalized with OCL.

3.3. Deriving relative positions between steps and transitions

The Grafcet interpretation algorithm makes use of relative positions between steps and transitions. For example, given a transition, it is necessary to evaluate all the input steps (upstream steps) and all the output steps (downstream steps). We provide a solution by using the OCL language to query metamodel instances.

Input steps of a transition : According to the model, a step is at the input of a transition if there exists a connection (of type StepToTransition) which is both at the output of this step and at the input of this transition. Input steps are obtained by creating the *inSteps* property in the context of Transition as presented on Listing 2:

Listing 2: Deriving inSteps property

```
property inSteps:Step[*] { derived volatile }
{ derivation: (grafcet.steps->select(step|step.outConnections->exists(outCon|
self.inConnections->includes(outCon))))->asSet(); }
```

Similarly, we create derived properties for output steps of a transition, input transitions of steps and output transitions of steps, all of which are required to implement the Grafcet evolution rules.

3.4. Model edition and validation

After the creation of the generation model (*.genmodel*), the project code is automatically generated within Eclipse EMF, including the code of a Grafcet editor, which has several views including a tree editor (*Sample Reflective Ecore Model Editor*) and a text editor. Here, we illustrate this editor using the Grafcet model of the example. Given the Grafcet model of Figure 1, we provide a corresponding Grafcet model with a labelling of connected links (as shown on Figure 3), allowing connections to be distinguished from each other.

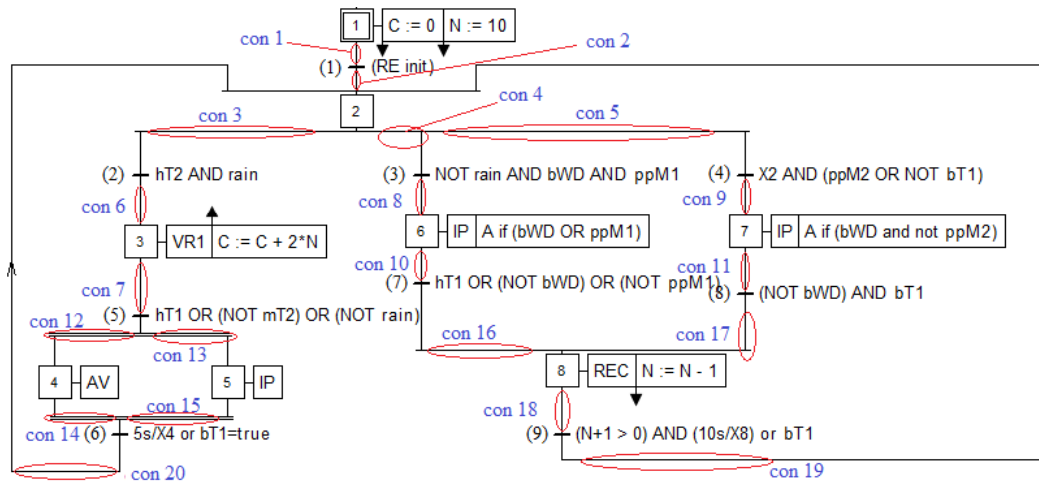

Figure 3. Grafcet example with the links labelled

All the derived features of this Grafcet model are automatically produced, according to section 3.3. Figure 4 shows an overview of this Grafcet model produced in the *Sample Reflective Ecore Model Editor*. All steps activity variables ($X1$, $X2$, ..., $X8$) are automatically built, as well as steps variables, actions and transitions expressions.

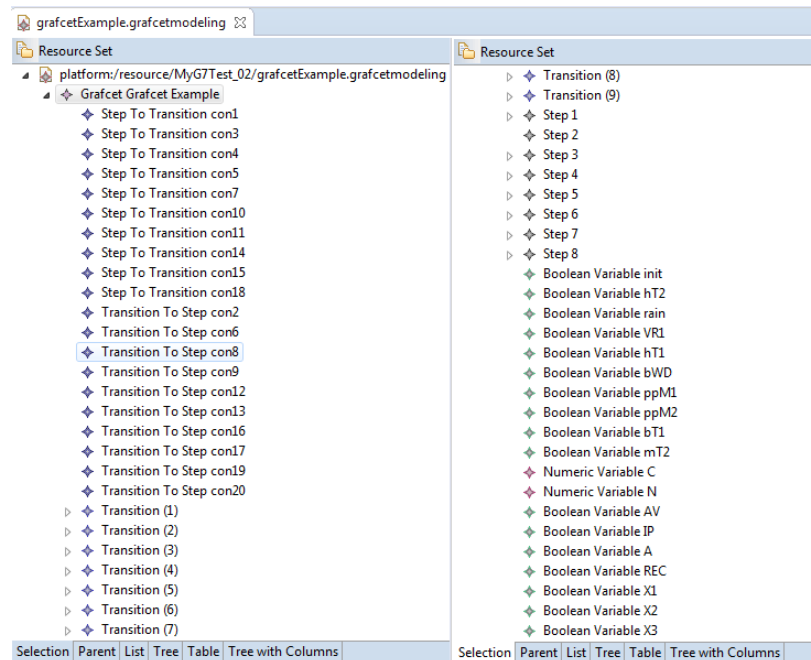

Figure 4. The Grafcet example in tree editor

Validation rules are associated to the Grafcet metamodel, and they must be verified on model instances by running the validation process.

4. Multi target code generation

This section starts with the specification of target platforms, before describing the transformation of Grafcet to control code.

4.1. Target platforms specification and metamodel

The microcontrollers programmable in a language derived from the C-language [17] are considered, and the metamodel of this family is given in Figure 5. As for the Grafcet, a microcontroller model editor is also obtained in Eclipse EMF, allowing the edition and saving models in XMI format for any use such as code generation.

The concepts of white color are describing the useful physical characteristics, those of purple color describe characteristics related with the C-language while the others (of light yellow) represent enumerated types or possible values of certain attributes of the model.

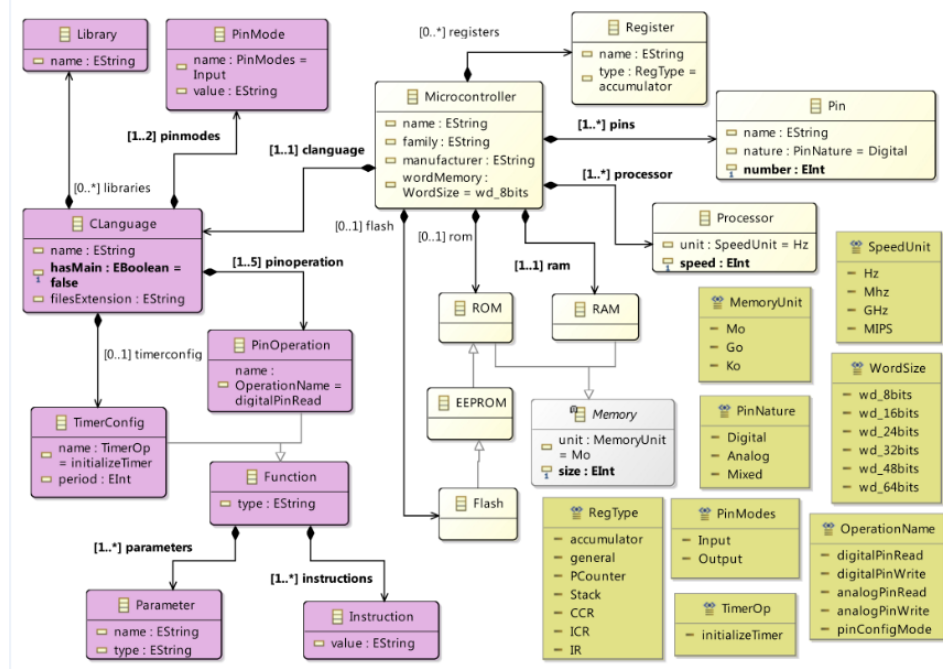

Figure 5. Microcontroller metamodel
4.2. Transformation step for code generation

Here is the MDE transformation process for Grafcet code generation that takes as input the model of the microcontroller target. The transformation is based on the correspondence of Grafcet-elements to C code fragments (M2T transformation), of the *Model-to-text/Concrete syntax* design pattern category. Table 1 of Annex 2 presents an overview of some basic code transformation rules.

Due to the sequential execution of instructions by microcontrollers, the Grafcet dynamics is stated in the code in terms of Grafcet algebraic equations presented in [1] and recalled in [9]. Here are the two main equations of the Grafcet dynamics. If $CC(tr)$ (Clearing Condition) is the Boolean variable associated to the transition tr , tr can be fired if it is enabled and if its associated transition condition $TC(tr)$ is true. $CC(tr)$ is calculated as shown on equation 1.

$$CC(tr) = \left(\prod_{i=1}^m X_i^{tr} \right) \times TC(tr) \quad [1]$$

where :

- X_i^{tr} is the step activity Boolean variable associated to step i and directly preceding transition tr ,
 - $TC(tr)$ is the transition condition associated to transition tr and
 - m is the number of steps immediately preceding the transition tr .
- $\prod_{i=1}^m X_i^{tr}$ expresses the condition for this transition to be validated.

After the initialization of activity variables, their update is computed as shown on equations 2.

$$X_i(t+1) = \sum_{j=1}^p CC(tr_j^{i-}) + X_i(t) \times \prod_{j=1}^q \overline{CC(tr_j^{i+})} \quad [2]$$

where :

- $X_i(t)$ is the step activity variable of step i in the t^{th} scan cycle,
- $X_i(t+1)$ is the step activity variable of step i in the $(t+1)^{th}$ scan cycle,
- p is the number of transitions directly preceding the step i ,
- q is the number of transitions directly succeeding the step i ,
- $CC(tr_j^{i-})$ is the clearing condition of transition j , directly preceding the step i and
- $CC(tr_j^{i+})$ is the clearing condition of transition j , directly succeeding the step i .

Grafcet expressions are transformed into C code using the C semantics of expressions described in [10].

5. A case study of code generation

This case study is intended to present an example of the implementation of the transformations for code generation for the family of microcontrollers presented here. We then present a particular case with the *Atmega328P* microcontroller [16].

5.1. The implementation of the transformation

The transformation program is organized by modules. Each module contains several templates and/or queries to extract information from the manipulated models and write the result in the file on output. The Acceleo language is then used to implement the transformation of Grafcet into code. It is an implementation of the MOFM2T specification defined by the OMG and is composed of two main types of structures: templates and queries. Templates are sets of Acceleo statements used to generate text, and queries are used to extract information from models.

The main module (*generateG7MM2Code.mtl*) contains one template providing the main structure of the code generated and outputted in a file, as shown on Figure 7 of Annex 3.

The general architecture of this transformation system is given in figure 6. The *Acceleo Transformation Engine* takes as input a valid grafcet model and a description of the architecture of the target microcontroller to execute the transformation rules and produce dedicated code as output.

5.2. Application to the *Atmega328P* microcontroller

5.2.1. *Atmega328P* microcontroller description and attributes

Atmega328P is a high-performance Microchip 8-bit microcontroller based on the AVR enhanced RISC architecture, manufactured by the Atmel company [16]. **The *Atmega328P* attributes used here for code generation are as follows:**

- Name: *Atmega328P*, Manufacturer: ATMEL, 8 bits word memory;
- 20MHz of processor, 2Ko of RAM, 32Ko of Flash memory, 1Ko of EEPROM;

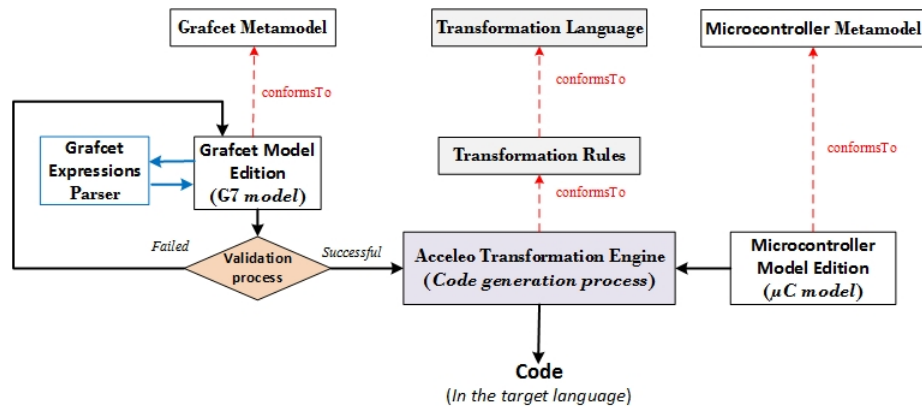

Figure 6. General architecture of the transformation system

- Programmable pins with numbers: PD0 (0) ... PD7(7), PB0 (8) ... PB7 (15), PC0 (0) ... PC5(28);

- C-language characteristics: Name: Arduino, Timer: Timer 1 of 16 bits;

- Pins operations :

`pinMode(pin_num, mode)`; to configure a pin number with a particular mode (INPUT/OUTPUT),

`digitalRead(pin_num)`; to read a digital value of a pin number,

`digitalWrite(pin_num, value)`; to write a digital value on a pin number,

`analogRead(pin_num)`; to read an analog value of a pin number,

`analogWrite(pin_num, value)`; to write an analog value on a pin number;

- Timer 1 configuration: `Timer1.initialize(1000000/(1000/TIMER_PERIOD))`;

`Timer1.attachInterrupt(update_G7TimingVars_callback)`;

To configure the Timer 1 (16 bits timer) with a period of `TIMER_PERIOD` milliseconds.

It calls periodically the function `update_G7TimingVars_callback`.

The core metamodel instance corresponding to ATmega328P is produced and used in the code generation process.

5.2.2. Generation of Grafcet code in Arduino language

An implementation of the *M2T transformation* has been executed to generate arduino code. After the selection of the Grafcet model, the microcontroller instance and the target directory, the transformation program is run and the target code is produced. An overview of the resulting code is presented in *Annex 4*.

This generated code is successfully compiled in the Arduino environment and executed by any Arduino board (Uno, Mega ...) equipped with the Atmega328P microcontroller and producing the expected behaviour.

6. Conclusion

The objective of this paper was to study the multy target synthesis of logic embedded controllers from Grafcet specification. We have proposed a Grafcet metamodel that considers all aspects of the Grafcet language, including time constraints and events. This has resulted in a Grafcet metamodel linked to a Grafcet expression parser that makes easy

the design of verified Grafcet models. To allow multi-target generation, we have proposed a microcontroller metamodel representing its main characteristics useful for code generation. Transformation rules have been designed for Grafcet code generation, given the model of the target microcontroller, with an implementation case study in the popular Eclipse MDE environment. The flexibility of the multi-target platform for embedded control synthesis, proposed in this paper, allows PLC technology to be used in a wide variety of applications that were not previously associated with PLCs. The proposal in this paper is completely transparent and can be easily adapted for any other purpose.

Annex 1 : Grafcet semantic constraints

Two different variables cannot have the same name :

Listing 3: uniqueNamesInVars constraint (Grafcet)

```
context Grafcet invariant uniqueNamesInVars :
    self.variables->forall(v1,v2| v1<>v2 implies v1.name<>v2.name);
```

An instance of *StepToTransition* can only link one step to one transition, i.e. only one incoming step :

Listing 4: validStepToTransition_StepSide constraint (Grafcet)

```
context Grafcet invariant validStepToTransition_StepSide :
    self.connections->select(c|c.oclIsTypeOf(StepToTransition))->forall(con|
        self.steps->select(s|s.outConnections->includes(con))->size()=1);
```

An instance of *StepToTransition* can only link one step one transition, i.e. only one outgoing Transition :

Listing 5: validStepToTransition_TransitionSide constraint (Grafcet)

```
context Grafcet invariant validStepToTransition_TransitionSide :
    self.connections->select(c|c.oclIsTypeOf(StepToTransition))->forall(con|
        self.transitions->select(t|t.inConnections->includes(con))->size()
        =1);
```

An instance of *TransitionToStep* can only link one transition to one step, i.e. only one outgoing Step :

Listing 6: validTransitionToStep_TransitionSide constraint (Grafcet)

```
context Grafcet invariant validTransitionToStep_TransitionSide :
    self.connections->select(c|c.oclIsTypeOf(TransitionToStep))->forall(con|
        self.transitions->select(t|t.outConnections->includes(con))->size()
        =1);
```

An instance of *TransitionToStep* can only link one transition to one step, i.e. only one incoming Transition :

Listing 7: validTransitionToStep_StepSide constraint (Grafcet)

```
context Grafcet invariant validTransitionToStep_StepSide :  
    self.connections->select(c|c.oclIsTypeOf(TransitionToStep))->forAll(con|  
        self.steps->select(s|s.inConnections->includes(con))->size()=1);
```

Any transition has at least one step in input and one step in output :

Listing 8: validTransition constraint (Transition)

```
context Transition invariant validTransition :  
    self.inConnections->size()>=1 and self.outConnections->size()>=1;
```

Any variable associated to a step (step activity variable) is an internal variable :

Listing 9: stepVarIsInternalVar constraint (Step)

```
context Step invariant stepVarIsInternalVar :  
    self.stepVariable.type = VarType::Internal;
```

Any variable representing a level action is of type *BooleanVariable* :

Listing 10: levelActionVarIsBoolVar constraint (LevelAction)

```
context LevelAction invariant levelActionVarIsBoolVar :  
    self.actionVariable.oclIsTypeOf(BooleanVariable);
```

Annex 2 : Some basic transformation rules

Table 1 presents these transformation rules.

Annex 3 : The main Acceleo module

This overview, dedicated to code generation, is shown in Figure 7.

Annex 4 : An overview of the Arduino code generated for the example

Listing 16: Overview of the Arduino code generated

```
#include "TimerOne.h"  
//**** Declare INPUT pins mapped **** Total : 9  
const byte pin_init_ = 2;  
...  
//**** Declare DIGITAL INPUT pins states **** Total : 9  
boolean init_, init__Old;
```

Tableau 1. Basic rules for the correspondence between Grafcet elements and C code

Grafcet element	Code generated
Receptivity calculation	<p>Receptivity calculation</p> <pre>R_<aTransition.name> = <aTransition.getCExpr(>>;</pre>
Clearing a transition computation	<p>Clearing a transition computation</p> <pre>CC_<aTransition.name> = VT_<aTransition.name> && R_<aTransition.name>; if(FT_<aTransition.name>) {transitions_fired = 1;}</pre>
Level action computation	<p>Level action computation</p> <pre>if(!<transitions_fired>){ //for every step <aStep> if(<aStep.variable.name>) { if(<aStep.actions(LevelActions) [0].expressionCondition.getCExpr(>>) <aStep.actions(LevelActions) [0].variable.name> = 1; } //for all level actions associated to the step <aStep> } }</pre>
updating outputs /actions	<p>updating outputs or actions</p> <pre>if(! <transitions_fired>){ if(<action.variable.name> != <action.variable.name> + "_Old"){ digitalWrite("pin_" + <action.variable.name>, <action.variable.name>); } //For every level action }</pre>
Duration of activity variables computation	<p>Duration of activity variables computation</p> <pre>if(FE(<aVariable.name>){ <aVariable.name>_duration = 0 ;} else if(<aVariable.name>){ <aVariable.name>_duration ++; }</pre>
	<pre>... const unsigned int TIMER_PERIOD = 100; //100 ms = 1/10 seconds //Program Initialization void setup(){ initializeTimer(); //INPUT PINs Configuration pinModeConfig(pin_init_, INPUT); pinModeConfig(pin_hT2, INPUT); ... //OUTPUT PINs Configuration pinModeConfig(pin_VR1, OUTPUT); pinModeConfig(pin_C, OUTPUT); ... //Inital steps activity variables initialization X1_Old = true;</pre>

```

generateG7MM2Code.mtl  generate_G7_declarations.mtl  generateG7Functions.mtl  generate_G7_structures.mtl  MicrocontrollerModeling.aird
1 [comment encoding = UTF-8 //]
2 [module generateG7MM2Code('http://www.example.org/grafcetModeling', 'http://www.example.org/microcontrollermodeling')]
3 [import G7MM2Code::main:generate_G7_structures/]
4 [import G7MM2Code::main:genG7Services/]
5 [template public generateMainCode(ag7 : Grafcet, aMicro : Microcontroller)]
6 [comment @main/]
7 [file ((ag7.name + '/' + ag7.name + '.'+aMicro.clanguage.filesExtension).replaceAll(' ', '_'), false, 'UTF-8')]
8 //Code generated from the g7 "[ag7.name/]" and the µC "[aMicro.name]"
9 //Date: [getTime()]
10 [generate_header_and_global_variables(ag7, aMicro)]
11 boolean transitions_fired;
12 void setup(){
13     [generate_initializations(ag7, aMicro)]
14 }
15 void loop(){
16     [generate_inputsBoardReading(ag7, aMicro)]
17     transitions_fired = 0;
18     [generate_next_state_calculations(ag7)]
19     [generate_outputs_calculations(ag7)]
20     if(!transitions_fired){
21         [generate UpdatingLevelActions_Outputs_variables(ag7, aMicro)]
22     }
23     [generate UpdatingStoredActions_Outputs_variables(ag7, aMicro)]
24     [generate_SaveOldModel_Variables(ag7)]
25 }
26 [if (aMicro.clanguage.hasMain)]
27 int main(void){
28     setup();
29     for ( ; ; ) loop(); // repeat indefinitely the function loop()
30     return 0;
31 }
32 [if]
33 [generate_other_functions(ag7, aMicro)]
34 [file]
35 [template]
36

```

Figure 7. Overview of the main Acceleo module for code generation

```

};
//Program loop
void loop(){
    //Reading states of Digital INPUT pins (Digital Input variables)
    init_ = digitalPinRead(pin_init_);
    hT2 = digitalPinRead(pin_hT2);
    ...
    //Evaluate validated transitions (variables)
    CC_1 = X1_Old ;
    ...
    CC_6 = X4_Old && X5_Old;
    ...
    //Evaluate Receptivities of transitions
    R_1 = (CC_1)? (init_Old == false && init_ == true): false ;
    R_3 = (CC_3)? ((! rain) && bWD) && ppM1): false ;
    ...
    //Evaluate Clearing/firing transitions conditions
    FT_1 = CC_1 && R_1;
    ...
    //Calculation if there is any transition fired : 2nd alternative
    transitions_fired = FT_1 || FT_2 || FT_3 || FT_4 || FT_5 || FT_6 || FT_7
        || FT_8 || FT_9 ;
    ...
    //Evaluate steps activity variables
    X1 = (X1_Old );
    X2 = FT_9 || FT_1 || FT_6 || (X2_Old && ! R_9 && ! R_1 && ! R_6);
    ...
    //Evaluate Digital OUTPUTs variables : 8
    if(transitions_fired == false){
        //Evaluate Level Actions Associated to Step 3 : 1
        if(X3){ if (1) {VR1 = true;}}
        ...
    }
}

```

```

}
//Evaluate Analog/Stored OUTPUTs variables
//Evaluate Stored Actions Associated to Step 1
//Step 1: Action C On Activation
if(X1_Old == false && X1 == true){
    C = 0;
}
...
//Updating LEVEL ACTIONS OR DIGITAL OUTPUTs
if(transitions_fired == false){
    //A stable situation is reached
    if(VR1_Old != VR1){
        digitalWrite(pin_VR1, VR1);
    }
    ...
}
...
// Keep the state of Xi variable in Xi_Old before the next cycle
X1_Old = X1;
...
}

void initializeTimer(){
    unsigned int FT_Steps = 1000/TIMER_PERIOD;
    Timer1.initialize(1000000/FT_Steps);
    Timer1.attachInterrupt(update_G7TimingVars_callback);
}

void update_G7TimingVars_callback(){
    //called periodically to update timing variables
    //Updating durations of steps activity variables for timing conditions
    //for the step 1
    if(X1_Old == true && X1 == false){
        X1_duration = 0;
    }else if(X1 == true){
        X1_duration ++;
    }
    ...
}
...
//Pin mode configuration
void pinModeConfig(int pin_num, int mode){
    pinMode(pin_num, mode);
}
...

```

7. Bibliographie

- [1] MACHADO J., SEABRA E., CAMPOS J.C., SOARES F., LE C., “Safe controllers design for industrial automation systems”, *Computers & Industrial Engineering*, Vol. 60(4), pp.635–653, 2011.

- [2] JULIUS R., SCHÜRENBERG M., SCHUMACHER F., FAY A., “Transformation of GRAFCET to PLC code including hierarchical structures”, *Control Engineering Practice*, 64, pp. 173–194, 2017.
- [3] SCHUMACHER F., FAY A., “Formal representation of GRAFCET to automatically generate control code”, *Control Engineering Practice*, 33, pp. 84–93, 2014.
- [4] SCHUMACHER F., SEBASTIAN SCHRÖCK, FAY A. , “Tool support for an automatic transformation of GRAFCET specifications into IEC 61131-3 control code”, *IEEE-ETFA*, pp. 486–491, 2013.
- [5] ROBERT JULIUS, THOMAS TRENNER, A. FAY, JOERG NEIDIG, XUAN LUU HOANG, “A meta-model based environment for GRAFCET specifications”, *2019 IEEE International Systems Conference (SysCon)*, pp. 1–7, 2019 <https://api.semanticscholar.org/CorpusID:202686480>
- [6] ROBIN MROSS, ARON SCHNAKENBECK, MARCUS VÖLKER, ALEXANDER FAY, STEFAN KOWALEWSKI, “Transformation of GRAFCET Into GAL for Verification Purposes Based on a Detailed Meta-Model”, *IEEE Access*, IEEE, vol. 10:pp. 125652–125665, 2022.
- [7] IEC 60848, “IEC 60848: GRAFCET specification language for sequential function charts (2nd ed.)”, *International Electrotechnical Commission publishing*, IEC, 2002.
- [8] IEC61131-3, “Programmable controllers - Part 3: programming languages (3rd ed.)”, *International Electrotechnical Commission publishing*, IEC, 2013.
- [9] NZEBOP NDENOKA G., SIMEU E., ALHAKIM R., “ Efficient controller synthesis of multi-energy systems for autonomous domestic water supply”, *Revue Africaine de la Recherche en Informatique et Mathématiques Appliquées*, vol. 24:pp. 65–88, 2017.
- [10] NZEBOP NDENOKA G., TCHUENTE M., SIMEU E., “ Langage et sémantique des expressions pour la synthèse de modèle Grafcet dans un environnement IDM”, *Revue Africaine de Recherche en Informatique et Mathématiques Appliquées*, Episciences.org, vol. 33 : 1–15, Nov. 2021.
- [11] DAVID R., “Grafcet: A Powerful Tool for Specification of Logic Controllers”, *IEEE Transactions on Control Systems Technology*, 3(3), pp. 253–268, 1995.
- [12] DA SILVA, ALBERTO RODRIGUES, “Model-driven engineering: A survey supported by the unified conceptual model”, *Computer Languages, Systems & Structures*, 43, pp. 139–155, 2015.
- [13] SOUKAINA M., ABDESSAMAD B., ABDELAZIZ M., “Model Driven Engineering (MDE) Tools: A Survey”, *American Journal of Science, Engineering and Technology*, 3(2), pp. 29–45, 2018.
- [14] QAMSANE Y., EL HAMLAOUI M., TAJER A., PHILIPPOT A., “A Model-Based Transformation Method to Design PLC-Based Control of Discrete Automated Manufacturing Systems”, *Proceedings of Engineering and Technology–PET*, 19, pp. 4–11, 2017.
- [15] BASCIANI F., DI RUSCIO, IOVINO L., PIERANTONIO A., “Automated chaining of model transformations with incompatible metamodels”, *Proceedings of Engineering and Technology–PET*, 19, pp. 4–11, 2017.
- [16] ATMEL, “ATMega328 datasheets”, <https://www.sparkfun.com/datasheets/Components/SMD/ATMega328.pdf>, Accessed: June. 2024.
- [17] BAYÓ-PUXAN O., RAFECAS-SABATÉ J., GOMIS-BELLMUNT O., BERGAS-JANÉ J., “A GRAFCET-compiler methodology for C-programmed microcontrollers”, *Assembly Automation*, Emerald Group Publishing Limited, 28(1), pp. 55–60, 2008.