



**HAL**  
open science

## Highly Irregular Graph Decompositions

Julien Bensmail, Malory Marin, Leandro Montero, Alexandre Talon

► **To cite this version:**

Julien Bensmail, Malory Marin, Leandro Montero, Alexandre Talon. Highly Irregular Graph Decompositions. Theoretical Computer Science, In press. hal-04662331v2

**HAL Id: hal-04662331**

**<https://hal.science/hal-04662331v2>**

Submitted on 17 Dec 2024

**HAL** is a multi-disciplinary open access archive for the deposit and dissemination of scientific research documents, whether they are published or not. The documents may come from teaching and research institutions in France or abroad, or from public or private research centers.

L'archive ouverte pluridisciplinaire **HAL**, est destinée au dépôt et à la diffusion de documents scientifiques de niveau recherche, publiés ou non, émanant des établissements d'enseignement et de recherche français ou étrangers, des laboratoires publics ou privés.

# Highly Irregular Graph Decompositions

Julien Bensmail<sup>a</sup>, Malory Marin<sup>b</sup>, Leandro Montero<sup>c</sup>, Alexandre Talon<sup>d</sup>

<sup>a</sup> *Université Côte d'Azur, CNRS, Inria, I3S, France*

<sup>b</sup> *Univ. Lyon, CNRS, ENS de Lyon, Université Claude Bernard Lyon 1, LIP UMR 5668, France*

<sup>c</sup> *IMT Atlantique, LS2N - CNRS, La Chantrerie, Nantes, France*

<sup>d</sup> *CNRS, Sorbonne Université, France*

---

## Abstract

We introduce and study decompositions of graphs into so-called highly irregular graphs, as first introduced by Alavi, Chartrand, Chung, Erdős, Graham and Oellermann in the 1980s. That is, given any graph, we are interested in colouring its edges with the least number of colours possible, so that, in each colour, no vertex has two neighbours with the same degree in that colour. We provide results of different natures on this problem. We first establish connections with other notions of graph theory, including other decomposition problems, from which we notably get first bounds on the associated chromatic parameter of interest. We then study this parameter for several common classes of graphs, including graphs of bounded degree, complete bipartite graphs and complete graphs, for which we establish (sometimes close to) tight results. We also provide negative and positive algorithmic results, showing that the problem of determining our new chromatic parameter is NP-complete in general, but polynomial-time tractable in particular contexts. We conclude with questions and problems for further work on the topic.

*Keywords:* highly irregular graph; graph decomposition; graph irregularity.

---

## 1. Introduction

A well-known concept in graph theory is that of regularity, where a graph is commonly considered *regular* if all its vertices have the same degree. A legitimate concern is then to wonder about possible antonyms to this notions of regularity, and, consequently, quite a few such concepts have been investigated in literature. Perhaps the most natural way to define graph irregularity is to consider that a graph is *totally irregular* (t.i. for short) if no two of its vertices have the same degree. However, it is a well-known fact that,  $K_1$  apart, no simple graph can be t.i. (just consider the degree sequence any such graph requires).

For this reason, several authors turned to weaker notions of graph irregularity. In particular, in the 1980s, Alavi, Chartrand, Chung, Erdős, Graham and Oellermann introduced in [3] the concept of **highly irregular graphs**, where a graph is *highly irregular* (h.i. for short) if none of its vertices has two neighbours with the same degree (in other words, every vertex can distinguish its neighbours degree-wise). In that line, another weaker notion of graph irregularity was introduced more recently in [5], in which Baudon, Bensmail, Przybyło and Woźniak say a graph is *locally irregular* (l.i. for short) if it has no two adjacent vertices with the same degree. Obviously not all simple graphs are h.i. or l.i.; however one can easily come up with infinitely many examples of simple graphs that are h.i. or l.i., thereby showing that these notions fit better with simple graphs. For the sake of keeping the current introduction short and bearable, and because our investigations in this paper

are mainly on h.i. graphs (and on t.i. and l.i. graphs to a lesser extent), we will not elaborate more on other notions of graph irregularity that have been considered in literature here, but we inform the interested reader that such other notions do exist (see *e.g.* [1]).

Studying irregular graphs (w.r.t. some notion of irregularity) is an interesting topic by itself, but it turns out that some of these graphs have also appeared in the study of different, seemingly unrelated problems. For instance, phrased differently, the *irregularity strength* (introduced in [9]) of a simple graph  $G$  can be defined as the minimum  $k \geq 1$  such that  $G$  can be turned into a t.i. multigraph by replacing each of its edges with at most  $k$  parallel edges. Another example is the so-called *1-2-3 Conjecture* (introduced in [13] and proved in [14]), which, under our terminology, asks whether, in general, any graph can be turned into a l.i. multigraph by replacing each of its edges with at most 3 parallel edges. A very similar concern, but for h.i. multigraphs, was investigated more recently in [7].

In the current work, we are more interested in **decomposition problems**, inspired by those introduced and considered in [5]. Recall that, for a graph  $G$ , a *decomposition*  $\mathcal{D}$  is a partition  $(E_1, \dots, E_k)$  of the edge set  $E(G)$ . Equivalently, note that  $\mathcal{D}$  can be regarded as a  $k$ -edge-colouring  $\phi$ , by which every vertex  $v$  of  $G$  gets, for any  $i \in \{1, \dots, k\}$ , some  *$i$ -degree*  $d_i(v)$ , being the number of its incident edges assigned colour  $i$  (or, equivalently, lying in  $E_i$ ). In [5], the authors observed that, in connection with the aforementioned 1-2-3 Conjecture, it might be useful, for some graph  $G$ , to determine the smallest number, denoted  $\chi_{\text{l.i.}}(G)$ , of l.i. graphs decomposing  $G$  (if such decompositions even exist). More formally,  $\chi_{\text{l.i.}}(G)$  can be defined as the smallest  $k \geq 1$  (if it exists) such that  $G$  admits a *l.i.  $k$ -edge-colouring*, *i.e.*, a  $k$ -edge-colouring  $\phi$  where every colour yields a l.i. graph (that is, if  $\phi(uv) = i$  for some edge  $uv$ , then  $d_i(u) \neq d_i(v)$ ). In particular, all l.i. graphs  $G$  satisfy  $\chi_{\text{l.i.}}(G) = 1$  and are in some sense the most convenient w.r.t. the 1-2-3 Conjecture (they already stand, as is, as l.i. multigraphs). The authors of [5] also identified other contexts where l.i. decompositions arise naturally when dealing with the 1-2-3 Conjecture (such as when considering regular graphs). Since their introduction, l.i. decompositions have been studied in several works, see *e.g.* [4, 6, 8, 16, 17, 18, 19, 22, 23, 24, 25]; more details will be given later in the current paper, as they connect to the results we provide.

Our goal in this work is to study such concerns in the context of h.i. graphs. For a graph  $G$ , a *h.i. decomposition* (or equivalently *h.i. edge-colouring*) is a decomposition (resp. an edge-colouring) of  $G$  where each part (resp. colour) yields a h.i. graph. We now define  $\chi_{\text{h.i.}}(G)$  as the smallest  $k \geq 1$  such that  $G$  admits a h.i. decomposition into  $k$  parts, or, equivalently, a h.i.  $k$ -edge-colouring. Similarly as for l.i. decompositions, studying h.i. decompositions can be motivated in several ways. In particular, the parameter  $\chi_{\text{h.i.}}(G)$  can be perceived as a measure of how far from being h.i. a graph  $G$  is, and, regarding [7], determining  $\chi_{\text{h.i.}}(G)$  may be useful in determining how to turn  $G$  into a h.i. multigraph. Let us emphasise that, as far as we are aware, these notions are new and have not been introduced and considered in previous works; the current work is thus the very first one dedicated to this topic.

This work is organised as follows. We start off in Section 2 by providing first insights into h.i. decompositions. Namely, we recall known aspects of h.i. graphs, and provide first observations and connections (with other graph theoretical notions) from which we proceed to establish initial general lower and upper bounds on the parameter  $\chi_{\text{h.i.}}$ . We then improve on these bounds throughout Sections 3 and 4, in which we focus on complete bipartite graphs and complete graphs, and provide dedicated decomposition methods leading to tighter estimates on the parameter  $\chi_{\text{h.i.}}$ . Section 5 is dedicated to complexity aspects; therein, we prove that the general problem of determining  $\chi_{\text{h.i.}}(G)$  is NP-complete for

general graphs  $G$ , and linear-time solvable when  $G$  has bounded tree-width and bounded maximum degree. We conclude in Section 6 with directions and questions for further work on the topic.

## 2. First insights into h.i. decompositions

In this section, we mainly give preliminary observations and results on h.i. decompositions. We begin by surveying, in Subsection 2.1, the main previous works dedicated to h.i. graphs. We then focus on h.i. decompositions through Subsections 2.2 and 2.3, providing general upper and lower bounds on the parameter  $\chi_{\text{h.i.}}$ .

### 2.1. Studied aspects of h.i. graphs

As mentioned in the introductory section, h.i. graphs were introduced as early as in the 1980s, by Alavi, Chartrand, Chung, Erdős, Graham and Oellermann in [3]. In this seminal work on the topic, the authors investigated several fundamental aspects of h.i. graphs, covering mainly existential and enumeration questions. In particular, they proved h.i. graphs on  $n$  vertices exist for all values of  $n$  not in  $\{3, 5, 7\}$ . They also considered the largest size (number of edges) of a h.i. graph with given order and provided first results which would later be complemented by results due to Majcher and Michael in [20] (resulting in optimal results, summarised in later Theorems 4.1 and 4.2).

In [3], the authors also considered questions such as the minimum order of a h.i. graph containing (as an induced subgraph) any prescribed graph, the minimum order of a h.i. tree with given maximum degree, the proportion of h.i. graphs with given order  $n$  (showing the ratio of the number of h.i. graphs of order  $n$  over the number of graphs of order  $n$  tends to 0 as  $n$  grows to infinity), and the independence number of h.i. graphs. This last concern was considered further in [2], where the authors provided results on h.i. trees, bipartite graphs and graphs with larger chromatic number.

Apart from these main matters, only a few more aspects of h.i. graphs have been investigated in literature. For instance, Majcher and Michael studied the degree sequence of h.i. graphs in [21]. We refer the interested reader to the literature listed above for more results of perhaps lesser importance.

### 2.2. Upper bounds on the parameter $\chi_{\text{h.i.}}$

It is worth noting that the smallest connected h.i. graphs are the path of length<sup>1</sup> 1 (with order 2), the path of length 3 (with order 4), and the graph (with order 6) obtained from the path of length 5 by adding an edge joining the two vertices with a neighbour of degree 1. As the order increases, h.i. graphs become very rare proportion-wise, and mainly for this reason, it is not clear what h.i. decompositions look like in general. However, the fact that the path of length 1 is h.i. ensures the existence of an h.i. edge-colouring for every graph by assigning a distinct colour to each edge. In other words, there are some connections between our new problem and the well-known notions of proper edge-colourings and chromatic index of graphs; because the reader might not be quite familiar with all these notions, we voluntarily establish these connections little by little in what follows.

**Observation 2.1.** *The parameter  $\chi_{\text{h.i.}}(G)$  is well defined for all graphs  $G$ . In particular, for every graph  $G$  we have  $\chi_{\text{h.i.}}(G) \leq |E(G)|$ .*

---

<sup>1</sup>Recall that the *length* of a path or cycle is its number of edges.

The latter part of the statement of Observation 2.1 is not that anecdotal. Recall indeed that, regarding l.i. decompositions, there exist infinitely many graphs that do not admit any l.i. decomposition [5], for example paths and cycles of odd length. Thus, although l.i. decompositions are in some sense easier to deal with (due to more local constraints, as will be highlighted later on), a somewhat surprising fact is that no graph escapes the notion of h.i. decompositions.

We can of course improve upon the simple upper bound in Observation 2.1 by remarking that a h.i. graph does not have to be connected. This implies that any edge-colouring where each colour induces a matching is h.i. Edge-colourings with this property are well known in graph theory, and are commonly called proper edge-colourings. More formally, an edge-colouring of a graph  $G$  is *proper* if no two adjacent edges (sharing a vertex) are assigned the same colour. The smallest  $k \geq 1$  such that  $G$  admits a proper  $k$ -edge-colouring is called the *chromatic index* of  $G$  and is denoted  $\chi'(G)$ .

It is a trivial fact that we have  $\Delta(G) \leq \chi'(G)$  for every graph  $G$ , where  $\Delta(G)$  is the maximum degree of  $G$ , and, by Vizing's Theorem [26], we also have  $\chi'(G) \leq \Delta(G) + 1$ . By previous remarks, we thus get the following improvement upon Observation 2.1:

**Theorem 2.2.** *For every graph  $G$ , we have  $\chi_{\text{h.i.}}(G) \leq \Delta(G) + 1$ .*

Regarding Vizing's Theorem, it is well known that graphs  $G$  of *class 1* (i.e., with  $\chi'(G) = \Delta(G)$ ) do exist, and similarly for those of *class 2* (i.e., with  $\chi'(G) = \Delta(G) + 1$ ). Actually, for any  $k \geq 3$ , there is no polynomial-time characterisation of class-1 graphs  $G$  with  $\Delta(G) = k$  (unless  $\text{P}=\text{NP}$ ), see [15]. Thus, we obtain a slightly better upper bound for class-1 graphs  $G$  ( $\chi_{\text{h.i.}}(G) \leq \Delta(G)$ ), but in general it is not obvious what these graphs are and it is also not obvious whether  $\chi_{\text{h.i.}}(G) \leq \Delta(G)$  also holds when  $G$  is a class-2 graph.

Actually, even for very simple graphs, we cannot improve upon Theorem 2.2:

**Theorem 2.3.** *If  $G$  is an odd-length cycle, then  $\chi_{\text{h.i.}}(G) = 3 = \Delta(G) + 1$ .*

*Proof.* This follows mainly from the fact that the only two connected h.i. graphs with maximum degree 2 are the paths of length 1 and 3, which have odd length, and thus that any colour of a h.i. edge-colouring of  $G$  must induce a collection of paths of length 1 and 3. Now, if a h.i. 2-edge-colouring of  $G$  existed, then, along  $G$ , these paths of odd length would alternate between colour 1 and 2, and we would have the same number of such paths in colour 1 as in colour 2. This is impossible, since these paths would cover an even number of edges, while  $G$  has an odd number of them. So,  $\chi_{\text{h.i.}}(G) \geq 3$ , and  $\chi_{\text{h.i.}}(G) = 3$  by Theorem 2.2.  $\square$

There are other contexts where we can take advantage of the graph structure to decompose into longer h.i. paths, and improve upon Theorem 2.2. Recall that an *Eulerian walk* in a graph is a walk traversing all edges exactly once, and that, by Euler's Theorem, a graph  $G$  admits such a walk if and only if it is connected and has at most two vertices with odd degree.

**Theorem 2.4.** *If  $G$  is a triangle-free graph admitting an Eulerian walk, then*

$$\chi_{\text{h.i.}}(G) \leq \left\lceil \frac{1}{3} \cdot |E(G)| \right\rceil + (|E(G)| \bmod 3).$$

*Proof.* Let  $\phi$  be the edge-colouring of  $G$  obtained as follows. Traverse any Eulerian walk  $\mathcal{E}$  of  $G$  from start to finish, and, as going along, assign a new colour to any three successive edges until there remain at most two uncoloured edges, to which we assign a new, distinct

colour each. Since  $G$  is triangle-free, note that, for any colour  $i$  assigned to any three successive edges  $uv$ ,  $vw$ , and  $wx$  of  $\mathcal{E}$ ,  $u$  cannot be equal to  $x$ , and thus colour  $i$  induces a path of length 3, thus a h.i. graph. Likewise, any colour  $i$  assigned to only one edge of  $G$  (at most two such colours have been used) induces a path of length 1, thus a h.i. graph. Thus,  $\phi$  is h.i., and the number of colours it assigns is the one claimed in the statement.  $\square$

We finish this subsection by mentioning an obvious fact, being that if some graph  $G$  can be decomposed into  $k$  graphs  $G_1, \dots, G_k$ , then a h.i. decomposition of  $G$  can be obtained by just combining independent h.i. decompositions of  $G_1, \dots, G_k$ :

**Lemma 2.5.** *If  $G$  is a graph with a decomposition  $\mathcal{D} = (E_1, \dots, E_k)$ , then*

$$\chi_{\text{h.i.}}(G) \leq \sum_{i=1}^k \chi_{\text{h.i.}}(G[E_i])$$

where  $G[E_i] = (V(G), E_i)$  for all  $1 \leq i \leq k$ .

### 2.3. Lower bounds on the parameter $\chi_{\text{h.i.}}$

Now that we have seen, through Theorem 2.2, that for any graph  $G$  the parameter  $\chi_{\text{h.i.}}(G)$  cannot exceed  $\Delta(G) + 1$ , one can naturally wonder whether this upper bound is tight in general, or, put differently, how far from  $\Delta(G) + 1$  the value of  $\chi_{\text{h.i.}}(G)$  can be. Recall that we got a partial answer through Theorem 2.3 using a pathological case.

The next results rely on the following definitions.

**Definition 2.6.** *Let  $G$  be a graph with a vertex  $v$ . For any  $x \in \{1, \dots, |V(G)| - 1\}$ , we denote by  $\text{nb}(v, x)$  the number of neighbours of  $v$  with degree  $x$ , and by  $\text{nb}^{\leq}(v, x)$  the number of neighbours of  $v$  with degree at most  $x$ .*

We can now write the following simple lower bound, reached for instance by star graphs, that is, complete bipartite graphs  $K_{1,m}$  (for  $m \geq 1$ ):

**Observation 2.7.** *For every graph  $G$ , we have  $\max_{v \in V(G)} \text{nb}(v, 1) \leq \chi_{\text{h.i.}}(G)$ .*

*Proof.* Consider any h.i. edge-colouring  $\phi$  of  $G$ , and focus on any vertex  $v$ . Assume  $v$  has  $d = \text{nb}(v, 1) \geq 2$  neighbours  $u_1, \dots, u_d$  with degree 1. Then note that, regardless the rest of  $\phi$ , all of  $vu_1, \dots, vu_d$  must be assigned pairwise distinct colours since otherwise  $v$ , in some colour, would have at least two neighbours with degree 1. Since this is true for all vertices of the graph, the bound holds.  $\square$

By the arguments of the previous proof, Observation 2.7 can be generalised to:

**Theorem 2.8.** *For every graph  $G$ , we have*

$$\max_{\substack{v \in V(G) \\ x \in \{1, \dots, \Delta(G)\}}} \left\lceil \frac{\text{nb}^{\leq}(v, x)}{x} \right\rceil \leq \chi_{\text{h.i.}}(G).$$

*Proof.* Let  $\phi$  be a h.i. edge-colouring of  $G$ . Consider any  $v \in V(G)$ , any  $x \in \{1, \dots, \Delta(G)\}$  and set  $d = \text{nb}^{\leq}(v, x)$ . For any colour  $i$  the  $i$ -degree of any of the  $d$  neighbours  $u_1, \dots, u_d$  of  $v$  with degree at most  $x$ , if non-zero, must lie in  $\{1, \dots, x\}$ . This implies that around  $v$  colour  $i$  can be assigned to at most  $x$  of the edges  $vu_1, \dots, vu_d$ . Thus, due to  $v$  and  $x$ , the number of required colours, if  $\phi$  is indeed h.i., is at least  $\lceil d/x \rceil$ . Since this reasoning holds for every  $v$  and  $x$ , the claimed lower bound holds.  $\square$

While the lower bound can be pretty bad in some cases (in the case of a regular graph  $G$ , the lower bound obtained is  $1 \leq \chi_{\text{h.i.}}(G)$ ), in other cases it might be pretty useful. For instance, we will highlight in Section 3 that it is more accurate for very unbalanced complete bipartite graphs, which have the property to have only two possible values for the degrees. For instance, in any complete bipartite graph  $K_{2,m}$ , there is a vertex  $v$  with degree  $m$  neighbouring vertices of degree 2 only (that is,  $\text{nb}(v, 2) = d(v) = m$ ). This example and generalisations result in the observation that  $\chi_{\text{h.i.}}(G)$  being large for a graph  $G$  does not require the minimum degree  $\delta(G)$  to be small as one may think (for instance because of Observation 2.7).

### 3. Complete bipartite graphs

In this section, we focus on h.i. decompositions of complete bipartite graphs  $K_{n,m}$ . Regarding l.i. decompositions, it was observed in [5] that we have  $\chi_{\text{l.i.}}(K_{n,m}) = 1$  if  $n \neq m$ , and  $\chi_{\text{l.i.}}(K_{n,m}) = 2$  otherwise. As will be seen throughout, things are more complex when it comes to h.i. decompositions.

A crucial tool we will use throughout this section, is the following notion.

**Definition 3.1.** A *half<sup>+</sup> graph*<sup>2</sup> is a bipartite graph with bipartition  $(U, V)$  such that no two vertices of  $U$  have the same degree and no two vertices of  $V$  have the same degree.

**Observation 3.2.** Every half<sup>+</sup> graph is h.i.

Half<sup>+</sup> graphs already appeared in the study of h.i. graphs, since, notably, half<sup>+</sup> graphs are, w.r.t. their order, the h.i. graphs with the most edges (see [3]). This property makes half<sup>+</sup> graphs nice candidates to decompose graphs into, when establishing upper bounds on the parameter  $\chi_{\text{h.i.}}$ . In particular, a perfect use case is the upcoming particular one (in which, note, the statement involves half graphs, not half<sup>+</sup> graphs).

In the next proof and later on, for a graph  $G$  and a set  $E$  of edges of  $G$ , we denote by  $G \setminus E$  the graph  $(V(G), E(G) \setminus E)$  obtained by removing the edges of  $E$  from  $G$  (but keeping the vertices these edges are incident to).

**Lemma 3.3.** Every complete bipartite graph  $K_{n,n}$  decomposes into two half graphs having  $n$  vertices in both parts of the bipartition. As a consequence,  $\chi_{\text{h.i.}}(K_{n,n}) = 2$ .

*Proof.* Since all vertices of  $K_{n,n}$  have degree  $n$ , note that if we have a spanning half graph  $H \subset K_{n,n}$ , then  $K_{n,n} \setminus E(H)$  is also a half graph. Let  $U = \{u_1, \dots, u_n\}$  and  $V = \{u_1, \dots, u_n\}$  denote the two parts of the bipartition of  $K_{n,n}$ , and consider the spanning subgraph  $H$  of  $K_{n,n}$  where

$$E(H) = \{u_i v_j \in E(K_{n,n}) : 1 \leq i \leq n, 1 \leq j \leq i\}.$$

It is easy to see that  $H$  is indeed a spanning half graph of  $K_{n,n}$ . Then, by assigning colour 1 to all edges of  $E(K_{n,n}) \cap E(H)$  and colour 2 to all other edges of  $K_{n,n}$ , we obtain a h.i. 2-edge-colouring of  $K_{n,n}$ . Hence,  $\chi_{\text{h.i.}}(K_{n,n}) = 2$ .  $\square$

Apart from decomposing graphs into two half<sup>+</sup> graphs as is, we will also use the fact that performing some particular small and easy modifications to a half<sup>+</sup> graph preserves properties of interest regarding h.i. decompositions. Namely:

---

<sup>2</sup>Be aware that the term *half graph* has been commonly used in literature to refer to balanced bipartite graphs with the degree property described in Definition 3.1. Our half<sup>+</sup> graphs are slightly different in that they are bipartite but not necessarily balanced.

**Observation 3.4.** *If  $G$  is a half<sup>+</sup> graph with bipartition  $(U, V)$  such that no vertex of  $U$  has degree 0, then adding an isolated vertex to  $U$  results in a half<sup>+</sup> graph. As a consequence, every complete bipartite graph  $K_{n,n+1}$  has  $\chi_{\text{h.i.}}(K_{n,n+1}) = 2$ , since  $\chi_{\text{h.i.}}(K_{n,n}) = 2$  by Lemma 3.3.*

**Observation 3.5.** *Let  $M$  be a perfect matching of a complete bipartite graph  $K_{n,n}$ . Then  $K_{n,n} \setminus M$  decomposes into two half<sup>+</sup> graphs. Therefore,  $\chi_{\text{h.i.}}(K_{n,n} \setminus M) = 2$ .*

*Proof.* This can be proved similarly as Lemma 3.3. □

**Observation 3.6.** *Let  $G$  be a graph obtained by adding a universal vertex to a balanced complete bipartite graph with the edges of a perfect matching removed. Then,  $\chi_{\text{h.i.}}(G) = 2$ .*

*Proof.* Assume  $G$  is obtained from  $K_{n,n}$  by removing the edges of a perfect matching  $M$  and adding a universal vertex  $w$ . By Observation 3.5, the edges of  $G \setminus \{w\}$  can be coloured with colours 1 and 2 so that each colour yields a half<sup>+</sup> graph, thus a h.i. graph by Observation 3.2. We extend this 2-edge-colouring to the edges incident to  $w$ , so that all edges incident to  $w$  going to  $U$  are assigned colour 1, while all those going to  $V$  are assigned colour 2, where  $(U, V)$  denotes the bipartitions of  $K_{n,n}$ . As a result, note that the 1-degrees of all vertices of  $U$  are increased by 1 and are still pairwise different, since prior to extending the edge-colouring, colour 1 induced a half<sup>+</sup> graph. Meanwhile, we have  $d_1(w) = n$  and  $w$ , through colour 1, is not adjacent to any vertex of  $V$ . Also the 1-degrees of the vertices of  $V$  have not been altered and are thus all pairwise distinct with value at most  $n - 1$  (since  $\Delta(K_{n,n} \setminus M) = n - 1$ ). Since these observations also apply to colour 2, the resulting 2-edge-colouring of  $G$  is h.i. □

We are now ready to study h.i. decompositions of complete bipartite graphs  $K_{n,m}$  (where  $n \leq m$ ). As a first intuition, it should be clear that  $\chi_{\text{h.i.}}(K_{n,m})$  should increase as the difference between  $n$  and  $m$  increases; this is attested by Theorem 2.8 (case where  $m - n$  is large) and Lemma 3.3 and Observation 3.4 (case where  $m - n$  is small). We first provide results establishing this intuition formally; we start with an upper bound.

**Theorem 3.7.** *For any two integers  $n, m$  with  $n \geq 1$  and  $m \geq n(n + 1)$ , we have*

$$\chi_{\text{h.i.}}(K_{n,m}) \leq 2 \left\lceil \frac{m}{n+1} \right\rceil.$$

*Proof.* Let  $(U, V)$  denote the bipartition of  $K_{n,m}$ , where  $|U| = n$  and  $|V| = m$ . The result is obtained mainly by showing that we can write  $m = k_1(n + 1) + k_2n$  for some  $k_1, k_2 \geq 0$ . Indeed, for such  $k_1$  and  $k_2$ , we can take an arbitrary partition of  $V$  into  $k_1$  sets of size  $n + 1$  and  $k_2$  sets of size  $n$ . Then, if  $A$  is any of these sets, then the result follows from the fact that the subgraph induced by  $(U, A)$  is isomorphic to either  $K_{n,n+1}$  or  $K_{n,n}$ , which both decompose into two h.i. graphs, by either Lemma 3.3 or Observation 3.4. It then follows, by Lemma 2.5, that  $\chi_{\text{h.i.}}(K_{n,m}) \leq 2(k_1 + k_2)$ .

We thus need to show that we can write  $m$  as desired, and that, regardless of  $k_1$  and  $k_2$ , we obtain the claimed bound on  $\chi_{\text{h.i.}}(K_{n,m})$ . For now, let us write  $m = q(n + 1) + r$ , where  $0 \leq r \leq n$  and  $q = \lfloor \frac{m}{n+1} \rfloor$ .

- If  $r = 0$ , then  $m = q(n + 1)$ ; thus,  $k_1 = q$  and  $k_2 = 0$ . Therefore, we obtain  $\chi_{\text{h.i.}}(K_{n,m}) \leq 2 \frac{m}{n+1} = 2 \left\lceil \frac{m}{n+1} \right\rceil$ .
- Otherwise, since  $m \geq n(n + 1)$  and  $q \geq n$ , we can write  $m = (q - n)(n + 1) + (n + 1)n + r$ , and thus  $m = (q - n + r)(n + 1) + (n + 1 - r)n$ . Therefore,  $k_1 = (q - n + r)$  and  $k_2 = n + 1 - r$ . We then obtain  $\chi_{\text{h.i.}}(K_{n,m}) \leq 2(q - n + r + n + 1 - r) = 2q + 2 = 2 \left\lceil \frac{m}{n+1} \right\rceil$ .



Hence we derive the claimed bound in all cases.  $\square$

We now prove that the upper bound in Theorem 3.7 is tight up to a constant factor.

**Theorem 3.8.** *For any two integers  $n, m$  with  $m \geq n \geq 1$ , we have*

$$\left\lceil 2 \frac{m}{n+1} \right\rceil \leq \chi_{\text{h.i.}}(K_{n,m}).$$

*Proof.* Let  $(U, V)$  be the bipartition of  $K_{n,m}$ , where  $|U| = n$  and  $|V| = m$ . The result follows mainly from the following observation:

**Claim 3.9.** *Any h.i. subgraph of  $K_{n,m}$  has at most  $n(n+1)/2$  edges.*

*Proof of the claim.* Let  $E$  be a set of edges of  $K_{n,m}$  that induces a h.i. graph  $H$ . Let  $d$  be the maximum degree in  $H$  of some vertex  $u$  of  $U$ . Then, all of its  $d$  neighbours in  $H$  are in  $V$  and have pairwise distinct degrees. Vertices in  $V$  have degree  $n$  in  $K_{n,m}$ , and the maximum degree, in  $H$ , of a vertex in  $V$  is at most  $n$ , hence  $d \leq n$ . Thus, any vertex of  $U$  has degree at most  $n$  in  $H$ .

Since all neighbours of  $u$  have distinct degrees in  $V$ , it has at least one neighbour  $v \in V$  of degree at least  $d$ . Then,  $v$  has at least  $d$  neighbours in  $U$ , each with a distinct degree in  $H$ . Since, in  $H$ , the maximum degree of a vertex in  $V(H) \cap U$  is  $d$ , vertex  $v$  has exactly  $d$  neighbours in  $U$  with, in  $H$ , all degrees in  $\{1, \dots, d\}$ . There remain  $n - d$  vertices in  $U$ , each having degree at most  $d$  in  $H$ . In total,  $E$  thus contains at most  $d(d+1)/2 + (n-d)d$  edges. This value is maximised when  $d = n$ , in which case  $|E| \leq n(n+1)/2$ .  $\diamond$

Back to the proof of Theorem 3.8, assume, towards a contradiction, that  $\chi_{\text{h.i.}}(K_{n,m}) < \left\lceil 2 \frac{m}{n+1} \right\rceil$ . This implies  $K_{n,m}$  must have a h.i. subgraph with more than  $n(n+1)/2$  edges, which contradicts Claim 3.9. So, the bound claimed holds.  $\square$

Note that the context of a complete bipartite graph  $K_{n,m}$  makes the result of applying Theorem 2.8 appropriate. Specifically, when  $n \leq m$ , we obtain  $\chi_{\text{h.i.}}(K_{n,m}) \geq \lceil m/n \rceil$ , which is less interesting than the lower bound provided in Theorem 3.8.

To finish this section, we determine (mainly through applying some previous ideas) the exact value of  $\chi_{\text{h.i.}}(K_{n,m})$  when one of  $n$  and  $m$  is small, *i.e.*, 2 or 3. Recall that  $\chi_{\text{h.i.}}(K_{1,m}) = m$ , by Observation 2.7.

**Corollary 3.10.** *For every  $m \geq 2$ , we have  $\chi_{\text{h.i.}}(K_{2,m}) = 2 \lfloor \frac{m}{3} \rfloor + (m \bmod 3)$ .*

*Proof.* First, we have  $\chi_{\text{h.i.}}(K_{2,2}) = 2$ ,  $\chi_{\text{h.i.}}(K_{2,3}) = 2$  and  $\chi_{\text{h.i.}}(K_{2,4}) = 3$ . Indeed, none of  $K_{2,2}$ ,  $K_{2,3}$  and  $K_{2,4}$  is h.i., so they do not admit h.i. 1-edge-colourings. By Theorem 3.8, we also have  $\chi_{\text{h.i.}}(K_{2,4}) \geq 3$ . Now, we provide, in Figure 1, h.i. 2-edge-colourings of  $K_{2,2}$  and  $K_{2,3}$  and a h.i. 3-edge-colouring of  $K_{2,4}$ , from which we deduce that the equalities hold.

When  $m \geq 5$ , where  $m = 3k + i$  for some  $k \geq 1$  and  $i \in \{0, 1, 2\}$ , we can (as we did in the proof of Theorem 3.7) decompose  $K_{2,m}$  into copies of  $K_{2,2}$ ,  $K_{2,3}$ , and  $K_{2,4}$  so that, from the equalities above, and from Lemma 2.5, we get an upper bound on  $\chi_{\text{h.i.}}(K_{2,m})$ . Regarding lower bounds, we employ Theorem 3.8 in what follows.

- If  $m = 3k$ , then  $K_{2,m}$  decomposes into  $k$  copies of  $K_{2,3}$ ; then  $\chi_{\text{h.i.}}(K_{2,m}) \leq 2k$ . By Theorem 3.8, we obtain  $2k \leq \chi_{\text{h.i.}}(K_{2,m})$ .
- If  $m = 3k + 1$ , then  $K_{2,m}$  decomposes into  $k - 1$  copies of  $K_{2,3}$  and one copy of  $K_{2,4}$ ; then  $\chi_{\text{h.i.}}(K_{2,m}) \leq 2(k-1) + 3 = 2k + 1$ . By Theorem 3.8, we obtain  $2k + \frac{2}{3} \leq \chi_{\text{h.i.}}(K_{2,m})$ .

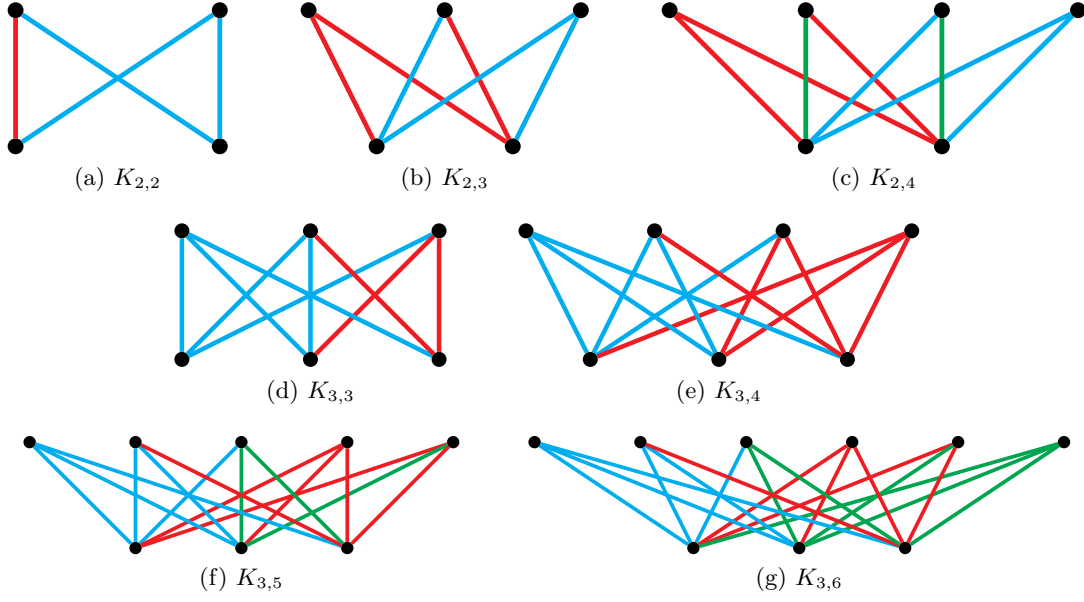

Figure 1: Optimal h.i. edge-colourings of small complete bipartite graphs.

- If  $m = 3k + 2$ , then  $K_{2,m}$  decomposes into  $k$  copies of  $K_{2,3}$  and one copy of  $K_{2,2}$ ; then  $\chi_{\text{h.i.}}(K_{2,m}) \leq 2k + 2$ . By Theorem 3.8, we obtain  $2k + \frac{4}{3} \leq \chi_{\text{h.i.}}(K_{2,m})$ .

The result then follows. □

**Corollary 3.11.** *For every  $m \geq 3$ , we have  $\chi_{\text{h.i.}}(K_{3,m}) = \lceil \frac{m}{2} \rceil$ .*

*Proof.* The proof is similar to that of Corollary 3.10. First, it can be observed that  $\chi_{\text{h.i.}}(K_{3,3}) = 2$ ,  $\chi_{\text{h.i.}}(K_{3,4}) = 2$ ,  $\chi_{\text{h.i.}}(K_{3,5}) = 3$  and  $\chi_{\text{h.i.}}(K_{3,6}) = 3$  (see Figure 1 again). Now, when  $m \geq 7$ , where  $m = 6k + i$  for some  $k \geq 1$  and  $i \in \{0, \dots, 5\}$ , we decompose  $K_{3,m}$  into copies of  $K_{3,3}$ ,  $K_{3,4}$ ,  $K_{3,5}$  and  $K_{3,6}$  so that Lemma 2.5 can be employed.

- If  $m = 6k$ , then  $K_{3,m}$  decomposes into  $k$  copies of  $K_{3,6}$ ; then  $\chi_{\text{h.i.}}(K_{3,m}) \leq 3k$ .
- If  $m = 6k + 1$ , then  $K_{3,m}$  decomposes into  $k - 1$  copies of  $K_{3,6}$ , one copy of  $K_{3,4}$ , and one copy of  $K_{3,3}$ ; then  $\chi_{\text{h.i.}}(K_{3,m}) \leq 3(k - 1) + 2 + 2 = 3k + 1$ .
- If  $m = 6k + 2$ , then  $K_{3,m}$  decomposes into  $k - 1$  copies of  $K_{3,6}$  and two copies of  $K_{3,4}$ ; then  $\chi_{\text{h.i.}}(K_{3,m}) \leq 3(k - 1) + 4 = 3k + 1$ .
- If  $m = 6k + 3$ , then  $K_{3,m}$  decomposes into  $k$  copies of  $K_{3,6}$  and one copy of  $K_{3,3}$ ; then  $\chi_{\text{h.i.}}(K_{3,m}) \leq 3k + 2$ .
- If  $m = 6k + 4$ , then  $K_{3,m}$  decomposes into  $k$  copies of  $K_{3,6}$  and one copy of  $K_{3,4}$ ; then  $\chi_{\text{h.i.}}(K_{3,m}) \leq 3k + 2$ .
- If  $m = 6k + 5$ , then  $K_{3,m}$  decomposes into  $k$  copies of  $K_{3,6}$  and one copy of  $K_{3,5}$ ; then  $\chi_{\text{h.i.}}(K_{3,m}) \leq 3k + 3$ .

Again, the result then follows from Theorem 3.8, since, if  $m = 6k + i$  for any  $i \in \{0, \dots, 5\}$ , then  $\lceil 2\frac{6k+i}{4} \rceil = 3k + \lceil \frac{i}{2} \rceil \leq \chi_{\text{h.i.}}(K_{3,m})$ . □

#### 4. Complete graphs

We now focus on complete graphs. When it comes to l.i. decompositions, there is a very nice way to prove that  $\chi_{\text{l.i.}}(K_n) \leq 3$  holds for all  $n \geq 4$ , see [5]. Essentially, this is done by considering an initial l.i. 3-edge-colouring of  $K_4$ , and gradually extending this 3-edge-colouring to larger complete graphs by repeatedly adding one vertex with all its incident edges, all assigned the same well-chosen colour.

Unfortunately, such an approach is unlikely to work for h.i. decompositions, for the simple reason that adding a universal vertex to a graph  $G$  can only result in a h.i. graph if  $G$  is t.i., thus if  $G = K_1$  (assuming  $G$  is indeed simple). Thus, in order to establish upper bounds on  $\chi_{\text{h.i.}}(K_n)$  for any complete graph  $K_n$ , one has to consider other approaches.

Before continuing with more promising methods, let us first discuss a natural one which, unfortunately, leads to upper bounds that are not optimal. Let  $K_n$  be a complete graph. In order to produce a h.i. edge-colouring  $\phi$  of  $K_n$  with few colours, one could be tempted to edge-colour  $K_n$  so that every colour yields a h.i. graph with the largest number of edges possible (for a graph with  $n$  vertices). It turns out that, in previous works, several authors managed to determine this largest quantity. It depends on the parity of  $n$ :

**Theorem 4.1** (Alavi *et al.*, [3]). *If  $G$  is a h.i. graph with even order  $n \geq 4$ , then*

$$|E(G)| \leq \frac{n(n+2)}{8}.$$

**Theorem 4.2** (Majcher, Michael [20]). *If  $G$  is a h.i. graph with odd order  $n = 2k + 1 \geq 9$ , then*

$$|E(G)| \leq \frac{1}{2}k(k+1) + \left\lceil \frac{1}{5}(k+1) \right\rceil.$$

Let us mention that the authors of Theorems 4.1 and 4.2 also proved that their bounds are sharp, in the sense that there exist h.i. graphs on  $n$  vertices with the stated maximum number of edges. The construction provided for  $n$  even is the most obvious, as it is that of half<sup>+</sup> graphs (with  $n/2$  vertices in each part) similar to those we considered in Lemma 3.3.

Exploiting such structures, we can establish a logarithmic upper bound on  $\chi_{\text{h.i.}}(K_n)$  for any  $n$ , which improves on the upper bounds we get from Observation 2.1 and Theorem 2.2. Such an upper bound is not the best possible for complete graphs, as we will see in Theorem 4.5; however, we think these ideas are interesting enough to be at least explained. Consider any complete graph  $K_n$ , and split its vertices into two sets,  $U$  and  $V$ , with about equal size  $n/2$ . Then the edges in the cut  $(U, V)$  form a (roughly) balanced complete bipartite graph  $K_{\frac{n}{2}, \frac{n}{2}}$ , which decomposes into two h.i. graphs by Lemma 3.3 (or by one of the subsequent observations we raised, in case it is not quite exactly balanced). It then remains to decompose the rest of the graph, whose edges form two disjoint complete graphs  $K$  and  $K'$  on about  $n/2$  vertices, for which we can repeat these arguments (taking into account that, in a h.i. edge-colouring, we can use the same colours in  $K$  and  $K'$  since they do not share vertices). Eventually, we then end up with a h.i. edge-colouring of  $K_n$  that uses a number of colours that is a logarithmic function of  $n$ .

Before we proceed with our most meaningful result in this section, let us first point out that Theorems 4.1 and 4.2 can also serve to establish lower bounds on  $\chi_{\text{h.i.}}(K_n)$  for any  $n$ . This follows from the following, more general (obvious) observation:

**Lemma 4.3.** *Let  $G$  be a graph with order  $n$ . If we denote by  $m(n)$  the largest number of edges in a h.i. graph on  $n$  vertices, then*

$$\left\lceil \frac{|E(G)|}{m(n)} \right\rceil \leq \chi_{\text{h.i.}}(G).$$

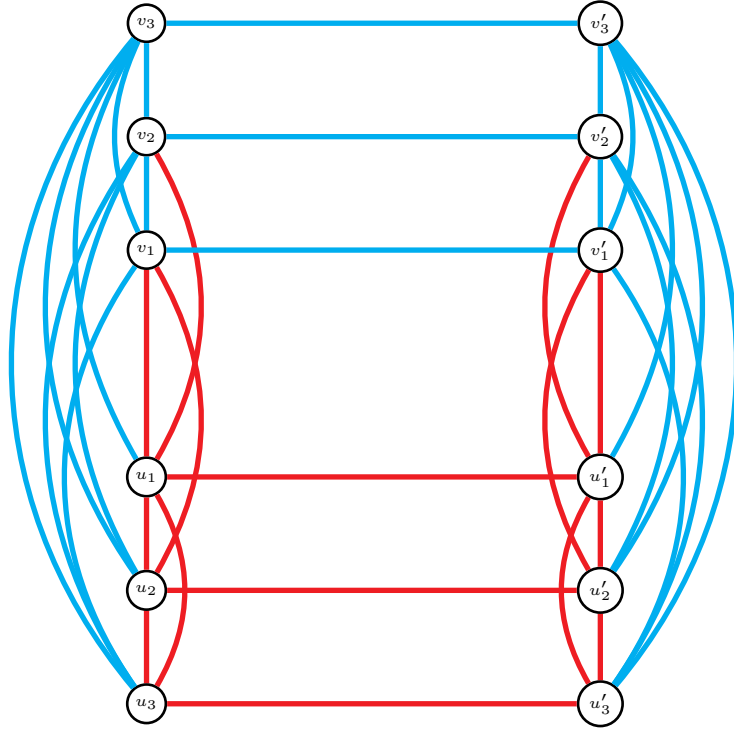

Figure 2: Part of the h.i. 4-edge-colouring of  $K_{12}$  described in the proof of Theorem 4.5. Red edges are edges assigned colour 1, while blue edges are edges assigned colour 2.

**Theorem 4.4.** *For every even  $n \geq 12$  and odd  $n \geq 9$ , we have  $4 \leq \chi_{\text{h.i.}}(K_n)$ .*

*Proof.* This follows mainly from combining Lemma 4.3, by considering that  $|E(K_n)| = \frac{n(n-1)}{2}$  and that  $m(n)$ , depending on the parity of  $n$ , is the extreme value indicated by either Theorem 4.1 or Theorem 4.2. In particular, for even values of  $n$ , it can be checked that the ratio in Lemma 4.3 is strictly larger than 3 when  $n \geq 12$ , and tends to 4 as  $n$  grows large. For odd values of  $n \geq 9$ , the ratio is strictly larger than 3 but less than 4.  $\square$

We now prove that the bound indicated in Theorem 4.4 is indeed correct in terms of magnitude. Let us mention that, in the upcoming proof, we draw inspiration from a construction in [3], used to show that for any  $n \geq 3$ , the smallest order of a h.i. graph containing  $K_n$  as an induced subgraph is  $4n - 4$ .

**Theorem 4.5.** *For every  $n \geq 1$ , we have  $\chi_{\text{h.i.}}(K_n) \leq 4$ .*

*Proof.* The claim is obviously true when  $n \leq 3$  (just assign a distinct colour to every edge to obtain a h.i. 4-edge-colouring); thus, we focus on cases where  $n \geq 4$ . We first prove the claim for values of  $n$  multiple of 4; by the end of the proof, we will then explain how to also derive the result for the remaining values of  $n$ . Set  $K = K_n$  and  $n = 4k$ . We denote by  $u_1, \dots, u_k, v_1, \dots, v_k, u'_1, \dots, u'_k$ , and  $v'_1, \dots, v'_k$  the vertices of  $K$ , and set  $U = \{u_1, \dots, u_k, v_1, \dots, v_k\}$  and  $V = \{u'_1, \dots, u'_k, v'_1, \dots, v'_k\}$ .

To build a h.i. 4-edge-colouring of  $K$ , our goal is to assign colour 1 and 2 to some sets  $E_1$  and  $E_2$ , respectively, of edges of  $K$ , so that  $K[E_1]$  and  $K[E_2]$  are h.i. (see Figure 2 for an illustration), and  $K \setminus (E_1 \cup E_2)$  is a balanced complete bipartite graph  $K_{\frac{n}{2}, \frac{n}{2}}$  with a perfect matching removed, which decomposes into two h.i. graphs by Observation 3.5.

We first assign colour 1 to the following edges, forming  $E_1$ :

- all edges of  $K[\{u_1, \dots, u_k\}]$  and  $K[\{u'_1, \dots, u'_k\}]$ ;

- $u_i u'_i$  for all  $i \in \{1, \dots, k\}$ ;
- the edges  $u_i v_1, u_i v_2, \dots, u_i v_{k-i}$  for all  $i \in \{1, \dots, k\}$ ;
- the edges  $u'_i v'_1, u'_i v'_2, \dots, u'_i v'_{k-i}$  for all  $i \in \{1, \dots, k\}$ .

To make it clearer,  $E_1$  thus contains, from  $U$ 's point of view, all edges  $u_1 v_1, \dots, u_1 v_{k-1}$ , all edges  $u_2 v_1, \dots, u_2 v_{k-2}$ , all edges  $u_3 v_1, \dots, u_3 v_{k-3}$ , and so on. In particular,  $E_1$  does not contain edges of the form  $u_k v_i$ . Similar observations can be made regarding  $V$ .

As a result, one can check that we have:

- $d_1(u_i) = d_1(u'_i) = (k-1) + 1 + (k-i) = 2k - i$  for all  $i \in \{1, \dots, k\}$ ;
- $d_1(v_i) = d_1(v'_i) = k - i$  for all  $i \in \{1, \dots, k\}$ .

In particular, we have

$$(d_1(u_1), \dots, d_1(u_k), d_1(v_1), \dots, d_1(v_k)) = (2k-1, \dots, 0),$$

from which we can easily deduce that  $K[E_1]$  is h.i.

We now assign colour 2 to the set  $E_2 \subset E(K) \setminus E_1$  of uncoloured edges of  $K$ :

- all edges of  $K[\{v_1, \dots, v_k\}]$  and  $K[\{v'_1, \dots, v'_k\}]$ ;
- $v_i v'_i$  for all  $i \in \{1, \dots, k\}$ ;
- all edges in  $\{u_1, \dots, u_k\} \times \{v_1, \dots, v_k\} \setminus E_1$ ;
- all edges in  $\{u'_1, \dots, u'_k\} \times \{v'_1, \dots, v'_k\} \setminus E_1$ .

Put differently,  $E_2$  contains all edges joining  $u_i$ 's and/or  $v_i$ 's (and similarly for  $u'_i$ 's and  $v'_i$ 's) that are not in  $E_1$ . In  $E_2$ , we also have the matching  $\{v_1 v'_1, \dots, v_n v'_n\}$ , so that all edges of  $K$  of the form  $u_i u'_i$  or  $v_i v'_i$  are in  $E_1 \cup E_2$ . In particular, all edges not in  $E_1 \cup E_2$  form a balanced complete bipartite graph  $K_{\frac{n}{2}, \frac{n}{2}}$  from which we removed a perfect matching, which, by Observation 3.5, can have its edges coloured with colours 3 and 4 yielding h.i. graphs.

To be done with  $K$ , it remains to show that  $K[E_2]$  is h.i., which follows from the following arguments. Note first that, for all  $i \in \{1, \dots, k\}$ , we have  $d_2(u_i) = d_U(u_i) - d_1(u_i) + 1 = 2k - (2k - i) = i$ , and, similarly,  $d_2(u'_i) = d_V(u'_i) - d_1(u'_i) + 1 = 2k - (2k - i) = i$ . Likewise, for all  $i \in \{1, \dots, k\}$ , we have  $d_2(v_i) = d_U(v_i) + 1 - d_1(v_i) = 2k - (k - i) = k + i$ , as well as  $d_2(v'_i) = d_V(v'_i) + 1 - d_1(v'_i) = 2k - (k - i) = k + i$ . From this, we deduce that

$$(d_2(u_1), \dots, d_2(u_k), d_2(v_1), \dots, d_2(v_k)) = (1, \dots, 2k),$$

and thus that  $K[E_2]$  is indeed h.i. Hence,  $\chi_{\text{h.i.}}(K) \leq 4$ .

We now explain how to derive the same upper bound for the remaining values of  $n$ .

- For any  $n \geq 6$  with  $n \equiv 2 \pmod{4}$ , consider the exact same 4-edge-colouring as above, but with  $v_k$  and  $v'_k$  removed. As a result, note that the 1-degrees of the  $u_i$ 's and  $u'_i$ 's are not altered, while the 1-degrees of the  $v_i$ 's and  $v'_i$ 's (other than  $v_k$  and  $v'_k$ ) are decreased by 1; thus, we still have that the  $u_i$ 's (and  $u'_i$ 's) have different 1-degrees larger than those (pairwise different) of the  $v_i$ 's (and  $v'_i$ 's), from which we get the edges assigned colour 1 still yield a h.i. graph. Likewise, all 2-degrees decreased by 1 since we removed  $v_n$  and  $v'_n$ , from which we deduce the edges assigned colour 2 yield a h.i. graph. Now, the edges assigned colour 3 or 4 are part of a balanced complete bipartite graph with a perfect matching removed, which we could recolour, if necessary, with colours 3 and 4 in a h.i. way by Observation 3.5. Altogether, we can thus design a h.i. 4-edge-colouring of  $K_n$  for the specified values of  $n$ .

- For any odd  $n \geq 5$ , consider any vertex  $w$  of  $K_n$ . By earlier arguments,  $K_n \setminus \{w\}$  admits a h.i. 4-edge-colouring where the edges assigned colours 3 and 4 form a balanced complete bipartite graph with a perfect matching removed. By Observation 3.6, this edge-colouring can be extended, with colours 3 and 4, in a h.i. way to the edges incident to  $w$ . Thus, here as well, a h.i. 4-edge-colouring of  $K_n$  exists.

This concludes the proof. □

Combining Theorems 4.4 and 4.5, we thus deduce that  $\chi_{\text{h.i.}}(K_n) = 4$  holds for all even  $n \geq 12$  and odd  $n \geq 9$ , which leaves the question open for small values of  $n$ . In what follows, we give the exact value of  $\chi_{\text{h.i.}}(K_n)$  for these remaining values of  $n$ , which we were able to establish by hand or through computer programs.

First, we observed that for  $n = 2, 3, 4, 5, 6, 7, 8, 10$ , the maximum size (number of edges) of a (not necessarily connected) h.i. graph with order  $n$  (and thus the maximum number of edges assigned a given colour by a h.i. edge-colouring) is 1, 1, 3, 3, 6, 6, 10, 15, respectively. From this we directly deduce that  $\chi_{\text{h.i.}}(K_n) \geq 4$  for all  $n \in \{5, 7, 8, 10\}$ , and thus we have  $\chi_{\text{h.i.}}(K_5) = \chi_{\text{h.i.}}(K_7) = \chi_{\text{h.i.}}(K_8) = \chi_{\text{h.i.}}(K_{10}) = 4$  by Theorem 4.5. For  $K_6$ , we were able to check exhaustively, through computer programs, that there is no h.i. 3-edge-colouring; so, again, we have  $\chi_{\text{h.i.}}(K_6) = 4$ . Finally, we have  $\chi_{\text{h.i.}}(K_4) = 2$  ( $K_4$  is not h.i., and it decomposes into two paths of length 3),  $\chi_{\text{h.i.}}(K_3) = 3$  by Theorem 2.3, and  $\chi_{\text{h.i.}}(K_2) = 1$  since  $K_2$  is h.i.

**Corollary 4.6.** *We have:*

- $\chi_{\text{h.i.}}(K_n) = 1$  for  $n = 2$ ;
- $\chi_{\text{h.i.}}(K_n) = 2$  for  $n = 4$ ;
- $\chi_{\text{h.i.}}(K_n) = 3$  for  $n = 3$ ;
- $\chi_{\text{h.i.}}(K_n) = 4$  otherwise, for all  $n \geq 5$ .

## 5. Complexity aspects

In this section, we investigate the computational complexity of determining  $\chi_{\text{h.i.}}(G)$  for a given graph  $G$ . We first prove, in upcoming Theorem 5.4, that deciding whether  $\chi_{\text{h.i.}}(G) \leq 2$  holds for a given graph  $G$  is NP-complete. An important point behind our proof of this result is that it also holds when restricted to bipartite graphs, which contrasts with the complexity of determining whether  $\chi_{\text{l.i.}}(G) \leq 2$  holds for a given graph  $G$ . Indeed, that latter problem was proved to be NP-complete for general graphs in [6], but its complexity for bipartite graphs is still unknown to date. We then prove in Theorem 5.5 that, on the other hand, determining  $\chi_{\text{h.i.}}(G)$  can be done in linear time for graphs  $G$  with bounded maximum degree  $\Delta(G)$  and tree-width  $\text{tw}(G)$ . A corollary we derive is that determining  $\chi_{\text{h.i.}}(T)$  for a tree  $T$  with bounded maximum degree can be done in linear time.

### 5.1. NP-completeness result

In Theorem 5.4 below, we prove that determining whether  $\chi_{\text{h.i.}}(G) \leq 2$  holds for a bipartite graph  $G$  is NP-complete. Before we get to the proof, we need to introduce some *forbidding gadgets* and point out some of their properties of interest w.r.t. h.i. 2-edge-colourings. All these gadgets will have a *root edge*  $uv$ , where  $d(u) = 1$  and  $v$  is called the *root vertex*. Given a graph  $G$  with a vertex  $w$  and a gadget  $H$  with root edge  $uv$  (where  $d(u) = 1$ ), by *attaching*  $H$  at  $w$  (through  $uv$ ), we mean adding  $H$  to  $G$ , and identifying

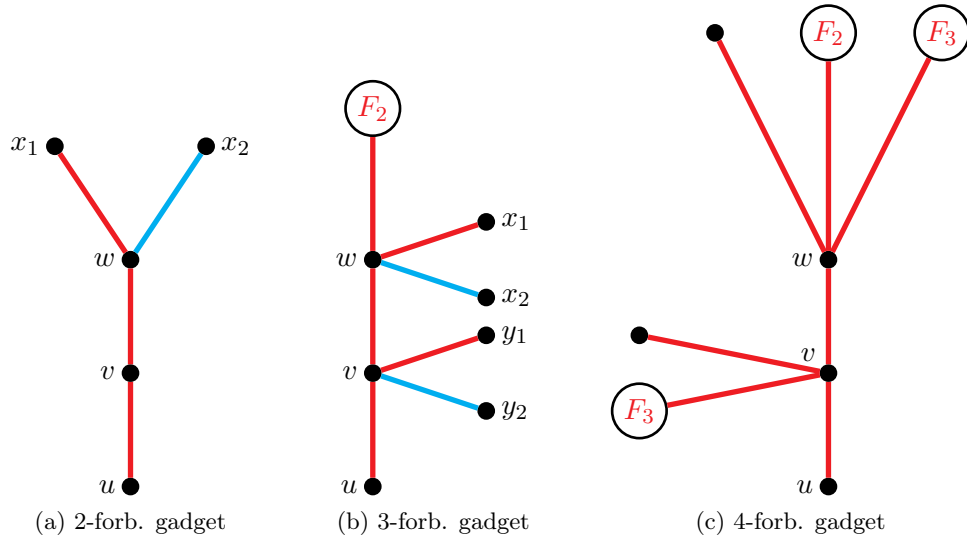

Figure 3: Examples of forbidding gadgets. “ $F_k$ ” inside a node indicates a  $k$ -forbidding gadget is attached at some vertex. Edges in red and blue form a h.i. 2-edge-colouring omitting conflicts along  $uv$  (root edge).

$u$  and  $w$ . The point is that our gadgets will forbid some values for  $d_1(w)$  and  $d_2(w)$ , assuming the resulting graph admits h.i. 2-edge-colourings. An important point is thus that, in a gadget to be attached, the  $i$ -degree of the non-root vertex  $u$  incident to the root edge cannot be regarded as fixed, as  $u$  will probably be incident to edges assigned colour  $i$  after the attachment. For these reasons, throughout what follows, when dealing with a h.i. 2-edge-colouring  $\phi$  of some forbidding gadget *omitting conflicts along the root edge*, we mean what we do not pay attention to possible conflicts involving the vertex of degree 1 incident to the root edge.

The first gadget  $H$  we introduce is the *2-forbidding gadget*, obtained as follows (see Figure 3 (a)). Start from a path  $uvw$  of length 2, and attach two vertices  $x_1$  and  $x_2$  of degree 1 at  $w$ . The root edge of  $H$  is  $uv$ , while  $v$  is its root. Throughout the subsequent discussion, we deal with the vertices and edges of  $H$  following this terminology.

**Lemma 5.1.** *For any h.i. 2-edge-colouring  $\phi$  of the 2-forbidding gadget  $H$  with  $\phi(uv) = i$ :*

- $d_i(v) = 2$ ;
- *in colour  $i$ , vertex  $v$  is adjacent to one vertex (different from  $u$ ) with  $i$ -degree 2.*

*Proof.* Note that we cannot have  $\phi(wx_1) = \phi(wx_2)$  as otherwise  $\phi$  would not be h.i. Thus, w.l.o.g. we must have  $\phi(wx_1) = 1$  and  $\phi(wx_2) = 2$ . Now, if, say,  $\phi(vw) = 1$ , then  $d_1(w) = 2$  and  $w$ , through  $wx_1$ , is adjacent to a vertex,  $x_1$ , with  $d_1(x_1) = 1$ . Thus we must have  $\phi(uv) = 1$  so that we do not have a conflict in colour 1. As a result, we have  $d_1(v) = 2$ , and  $v$ , through  $vw$  (assigned colour 1), is adjacent to a vertex,  $w$ , with  $d_1(w) = 2$ . Note as well that we do not have a conflict in colour 2. Of course, these arguments and observations apply if we permute colours 1 and 2 by  $\phi$ ; thus the claim holds.  $\square$

The *3-forbidding gadget*  $H$  is then obtained as follows (see Figure 3 (b)). Start from a path  $uvw$  of length 2, attach a 2-forbidding gadget  $F$  at  $w$  (that is, recall, identify  $w$  and the root vertex of  $F$ ), as well as two vertices  $x_1$  and  $x_2$  of degree 1, and finally attach similarly at  $v$  two vertices  $y_1$  and  $y_2$  of degree 1. The root edge of  $H$  is  $uv$ , while  $v$  is its root.

**Lemma 5.2.** *For any h.i. 2-edge-colouring  $\phi$  (omitting conflicts along the root edge) of the 3-forbidding gadget  $H$  with  $\phi(uv) = i$ :*

- $d_i(v) = 3$ ;
- in colour  $i$ , vertex  $v$  is adjacent to two vertices (different from  $u$ ) with all  $i$ -degrees in  $\{1, 3\}$ .

*Proof.* As earlier, note that  $wx_1$  and  $wx_2$  must be assigned distinct colours by  $\phi$ , and similarly for  $vy_1$  and  $vy_2$ . Assuming now, w.l.o.g., that the root edge of  $F$  is assigned colour 1, by Lemma 5.2 we know that the root  $r$  of  $F$  has 1-degree 2, and that  $r$  is adjacent, through edges assigned colour 1, to a vertex (different from  $w$ ) with 1-degree 2. Thus, so that we do not have a conflict in colour 1, we must have  $\phi(vw) = 1$  so that  $d_1(w) = 3$ . Likewise, since  $w$  is adjacent, through the edge  $wr$ , to a vertex ( $r$ ) with 1-degree 2, we must have  $\phi(uw) = 1$  so that we do not have a conflict in colour 1, which implies  $d_1(v) = 3$ . One can check as well that we do not have a conflict in colour 2. Thus the claim holds, since all these arguments also hold upon permuting colours 1 and 2.  $\square$

The general form of  $k$ -forbidding gadgets for  $k \geq 4$  is then as follows (see Figure 3 (c) for an example). Let  $k \geq 4$  be a value such that  $i$ -forbidding gadgets have been constructed for all  $i \in \{2, \dots, k-1\}$ . We construct a  $k$ -forbidding gadget  $H$  as follows. Start from a path  $uvw$  of length 2. The beginning of the construction then depends on the value of  $k$ .

- If  $k = 5$ , then we attach at  $w$  two vertices of degree 1, one 2-forbidding gadget  $F_2$ , two 3-forbidding gadgets  $F_3$  and  $G_3$ , and one 4-forbidding gadget  $F_4$ .
- If  $k \neq 5$ , then we attach at  $w$  one vertex of degree 1, as well as one  $i$ -forbidding gadget  $F_i$  for all  $i \in \{2, \dots, k-1\}$ .

Then, regardless of the value of  $k$ , we attach, at  $v$ , one vertex of degree 1, as well as one  $i$ -forbidding gadget  $F'_i$  for all  $i \in \{2, \dots, k-1\} \setminus \{k-2\}$ . In both cases, the root edge of  $H$  is  $uv$ , while  $v$  is its root.

**Lemma 5.3.** *For any  $k \geq 4$  and any h.i. 2-edge-colouring  $\phi$  (omitting conflicts along the root edge) of the  $k$ -forbidding gadget  $H$  with  $\phi(uv) = i$ :*

- $d_i(v) = k$ ;
- in colour  $i$ , vertex  $v$  is adjacent to  $k-1$  vertices (different from  $u$ ) with all  $i$ -degrees in  $\{1, \dots, k\} \setminus \{k-2\}$ .

*Proof.* We prove the claim by induction on  $k$ . By previous Lemmas 5.1 and 5.2, and by the induction hypothesis, recall that for any  $j$ -forbidding gadget  $F$  attached at  $v$  or  $w$ , we have the property that if the root edge of  $F$  is assigned colour  $i$ , then the root of  $F$  has  $i$ -degree  $j$  and is adjacent, in colour  $i$ , to vertices (different from the attachment point) with all  $i$ -degrees in  $\{1, \dots, j\} \setminus \{j-2\}$ .

W.l.o.g., assume the root edge of  $F_{k-1}$  is assigned colour 1 by  $\phi$ . We claim that  $d_1(w) = k$  and  $\phi(vw) = 1$ . Notice that, if  $k \neq 5$ , we claim all edges incident to  $w$  must be assigned the same colour by  $\phi$ . Suppose towards a contradiction that this is not the case. In the following explanations, we mostly assume  $k \neq 5$  since the construction of  $F_5$  is slightly different from the others; while some of the upcoming arguments also apply when  $k = 5$ , we will voluntarily treat this case separately later on. In particular, this means, throughout



what follows, that  $F_{k-2}$  is not  $F_3$  (which has a bit of a different behaviour, recall the last item of Lemma 5.2).

By Lemmas 5.1 and 5.2 and the induction hypothesis, the root of  $F_{k-1}$  is adjacent, in colour 1, to vertices (different from  $w$ ) with all 1-degrees in  $\{1, \dots, k-1\} \setminus \{k-3\}$ . Therefore, since  $d(w) = k$ , it must be that  $d_1(w) = k-3$ . Then, we must have  $d_2(w) = 3$ . Note also that, since  $k \neq 5$ , the root edge of  $F_{k-2}$  cannot be assigned colour 1, as otherwise the root of  $F_{k-2}$  would be adjacent, in colour 1, to two vertices with 1-degree  $k-3$  (including  $w$ ). So, the root edge of  $F_{k-2}$  must be assigned colour 2 by  $\phi$ . Now, so that the root of  $F_{k-2}$  is not adjacent, in colour 2, to two vertices with 2-degree 3, it must be that either  $(k-2) - 2 = 3$  or  $3 > k-2$ . That is, we get a contradiction to  $\phi$  being h.i. in all cases but when  $k = 7$  and  $k < 5$  (that is, when  $k = 4$ ). Recall we also have to reconsider when  $k = 5$ .

- First, consider when  $k = 7$ ; recall that, here,  $d(w) = 7$ . By arguments above, under the assumption that the root edge of  $F_6$  is assigned colour 1 by  $\phi$ , we have  $d_1(w) = 4$  and  $d_2(w) = 3$ . Now, still by arguments above, the root edge of  $F_5$  must be assigned colour 2, and the root edge of  $F_4$  cannot be assigned colour 2, as otherwise the root of  $F_4$  would be adjacent, in colour 2, to two vertices with 2-degree 3 (including  $w$ ). Then the root edge of  $F_4$  is assigned colour 1 by  $\phi$ , implying, by the induction hypothesis, that the root of  $F_4$  is adjacent, in colour 1, to two vertices (including  $w$ ) with 1-degree 4, a contradiction.
- Now consider when  $k = 4$ ; here,  $d(w) = 4$ . By arguments above and Lemma 5.2, assuming the root edge of  $F_3$  is assigned colour 1 w.l.o.g., we must have  $d_1(w) = 2$ , and, thus,  $d_2(w) = 2$ . Then, by Lemma 5.1, regardless of the actual colour assigned to the root edge of  $F_2$ , in that colour,  $i$ , there is necessarily a vertex (the root of  $F_2$ ) adjacent to two vertices (one of which is  $w$ ) with  $i$ -degree 2. This is a contradiction.
- Last, consider when  $k = 5$ , in which case  $d(w) = 7$ . By similar arguments as earlier, note that the two pendant edges incident to  $w$  must be assigned distinct colours by  $\phi$ , and similarly for the root edges of  $F_3$  and  $G_3$ . W.l.o.g., assume now the root edge of  $F_4$  is assigned colour 1. Now observe that we must have  $d_1(w) \in \{3, 4, 5\}$ , and if  $d_1(w)$  is not 5, then we have a conflict in colour 1, due to the root of  $F_4$  having two neighbours (including  $w$ ) with 1-degree 3 or 4. This is, again, a contradiction.

Thus, as stated earlier, assuming  $\phi(vw) = 1$ , we must have  $d_1(w) = k$  (as mentioned earlier, if  $k \neq 5$ , this means all edges incident to  $w$  must be assigned colour 1), and, by arguments above, it can be checked there is indeed a way to colour the edges incident to  $w$  accordingly. Now, again, we claim all edges incident to  $v$  must be assigned colour 1. This is simply because, even when  $k = 5$ , we have  $\phi(vw) = 1$  and in colour 1 vertex  $w$  is already adjacent to vertices (different from  $v$ ) with all 1-degrees in  $\{1, \dots, k-1\}$ . Thus to avoid any conflict, and because  $d(v) = k$ , we must have  $d_1(v) = k$ , which raises no conflict since only  $v$  and  $w$  have 1-degree  $k$ . Note further, by Lemmas 5.1 and 5.2 and the induction hypothesis, that since the root edges of the  $F_i$ 's get assigned colour 1, necessarily  $v$  gets also adjacent, in colour 1, to vertices (different from  $u$ ) with all  $i$ -degrees in  $\{1, \dots, k-1\} \setminus \{k-2\}$ . In the case  $k = 5$ , remark also that, by arguments above, we have  $d_2(w) = 2$ , while, in colour 2, the two neighbours of  $w$  have 2-degree 1 and 3, while none of these vertices have another neighbour with 2-degree 2.  $\square$

An important point to raise, is that  $k$ -forbidding gadgets have a size that is a function of  $k$  only. We are now ready to prove our main result, which is obtained by reduction from some restriction of MONOTONE NOT-ALL-EQUAL 3SAT, which we recall now for

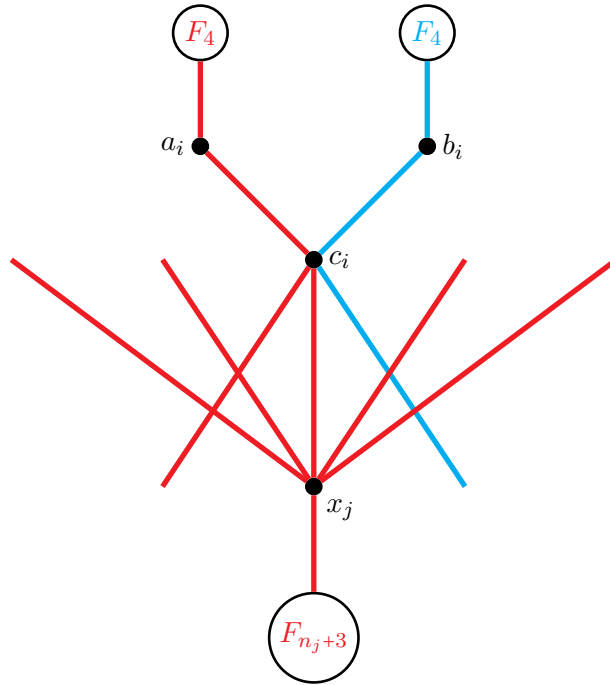

Figure 4: Part of the reduction in the proof of Theorem 5.4. “ $F_k$ ” inside a node indicates a  $k$ -forbidding gadget is attached at some vertex. Edges in red and blue form a (partial) h.i. 2-edge-colouring.

convenience. Remind that an instance of MONOTONE NOT-ALL-EQUAL 3SAT is a 3CNF formula  $F$  over clauses  $C_1, \dots, C_m$  and variables  $x_1, \dots, x_n$ , where every clause contains exactly three distinct (positive) variables, and the question is whether we can satisfy  $F$  in a *nae way*, *i.e.*, so that every clause contains both a true variable and a false variable. Obviously, it can be assumed that all variables of  $F$  appear in at least two distinct clauses, as otherwise the formula could be simplified (namely, for any formula  $F \wedge C$  where  $C$  contains a variable  $x$  that appears in  $C$  only, any solution to  $F$  can be extended to one of  $F \wedge C$  by setting  $x$  to some appropriate truth value, and *vice versa*). It is known as well that MONOTONE NOT-ALL-EQUAL 3SAT remains NP-complete when restricted to instances where each variable appears in at most four distinct clauses [12].

**Theorem 5.4.** *Determining whether  $\chi_{\text{h.i.}}(G) \leq 2$  holds for a given graph  $G$  is NP-complete.*

*Proof.* Since the problem is obviously in NP, we focus on proving its NP-hardness, which we do by reduction from MONOTONE NOT-ALL-EQUAL 3SAT. Let thus  $F$  be any instance of MONOTONE NOT-ALL-EQUAL 3SAT over clauses  $C_1, \dots, C_m$  and variables  $x_1, \dots, x_n$ , where all clauses contain three distinct variables and all variables appear in either two, three, or four distinct clauses. Note that, free to consider *e.g.* the equivalent formula  $F \wedge F \wedge F$ , we can assume each variable  $x_i$  of  $F$  appears in at most  $n_i \in \{6, \dots, 12\}$  clauses each. From  $F$ , we construct, in polynomial time, a graph  $G$  such that  $F$  can be satisfied in a *nae way* if and only if  $G$  admits h.i. 2-edge-colourings.

We construct  $G$  as follows (see Figure 4 for an illustration). Start from the bipartite graph modelling the structure of  $F$ , that is, having a *variable vertex*  $v_i$  for every variable  $x_i$ , a *clause vertex*  $c_j$  for every clause  $C_j$ , and a *formula edge*  $v_i c_j$  whenever variable  $x_i$  appears in clause  $C_j$ . Next, for every clause vertex  $c_j$ , add two vertices  $a_j$  and  $b_j$ , attach one 4-forbidding gadget at  $a_j$  and one 4-forbidding gadget at  $b_j$ , and finally add the edges  $c_j a_j$  and  $c_j b_j$ . Last, for every variable vertex  $v_i$ , assuming variable  $x_i$  appears in  $n_i \geq 6$  clauses of  $F$  (where, thus,  $6 \leq n_i \leq 12$ ), attach a  $(n_i + 3)$ -forbidding gadget at  $v_i$ . In

particular, since  $n_i \leq 12$ , note that we employ forbidding gadgets with constant size; under this, the whole construction of  $G$  is achieved in polynomial time.

To see that we have the desired equivalence between  $F$  and  $G$ , let us discuss how a h.i. 2-edge-colouring  $\phi$  of  $G$  should look like.

- Regarding any  $a_j$  (or similarly any  $b_j$ ), if the root edge of the attached 4-forbidding gadget is assigned, say, colour 1, then, by Lemma 5.3, in colour 1 vertex  $a_j$  is adjacent to a vertex having neighbours (different from  $a_j$ ) with all  $i$ -degrees in  $\{1, 3, 4\}$ . Then, since  $d(a_j) = 2$ , so that we do not have a conflict in colour 1, we must have  $\phi(a_j c_j) = 1$  so that  $d_1(a_j) = 2$ .
- For any clause vertex  $c_j$ , note that if the two edges  $c_j a_j$  and  $c_j b_j$  are assigned the same colour, say 1 w.l.o.g., then by arguments above we get a contradiction since  $c_j$  is then adjacent in colour 1 to two vertices with  $i$ -degree 2. Thus we must have, say,  $\phi(c_j a_j) = 1$  and  $\phi(c_j b_j) = 2$ . Then in colour 1 vertex  $c_j$  is adjacent to a vertex,  $a_j$ , having, in colour 1, a neighbour (the root vertex of some 4-forbidding gadget) with 1-degree 4, while we have the same regarding  $b_j$  w.r.t. colour 2. This implies all three formula edges incident to  $c_j$  cannot be assigned the same colour by  $\phi$ , as otherwise we would get  $d_1(c_j) = 4$  or  $d_2(c_j) = 4$ , thus a conflict in a colour. Meanwhile, if not all formula edges incident to  $c_j$  are of the same colour, then  $\{d_1(c_j), d_2(c_j)\} = \{2, 3\}$ , while  $a_j$  and  $b_j$  have no other neighbours with 1-degree or 2-degree in  $\{2, 3\}$ .
- For any variable vertex  $v_i$ , assuming the attached  $(n_i + 3)$ -forbidding gadget has its root edge assigned colour, say, 1, because  $n_i \geq 6$  and thus  $n_i + 3 \geq 9$ , we know by Lemma 5.3 that, in colour 1, vertex  $v_i$  has a neighbour adjacent, in colour 1, to vertices (different from  $v_i$ ) with all 1-degrees in  $\{1, \dots, n_i + 3\} \setminus \{n_i + 1\}$ . Meanwhile,  $d(v_i) = n_i + 1$ . From this, we deduce that we must have all  $n_i$  formula edges incident to  $v_i$  assigned colour 1, so that no conflict arises in colour 1.
- By these arguments, every clause vertex  $c_j$  must satisfy  $\{d_1(c_j), d_2(c_j)\} = \{2, 3\}$ , while every variable vertex  $v_i$  must satisfy  $\{d_1(v_i), d_2(v_i)\} = \{0, n_i + 1\}$  with  $n_i \geq 6$ . Also, besides variable vertices, clause vertices are only adjacent to  $a_i$ 's and  $b_i$ 's, which have 1-degree and 2-degree 0 and 2 (or *vice versa*), while, besides clause vertices, variable vertices are only adjacent to root vertices of  $d$ -forbidding vertices for  $d \geq 9$  (thus with 1-degree and 2-degree 0 and  $d \geq 9$ , or *vice versa*). From this all, we deduce no conflict can involve a clause vertex and an adjacent variable vertex in any colour.

Now, to see that we have the desired equivalence, just imagine that having  $\phi(c_j v_i) = 1$  for some formula edge  $c_j v_i$  models that variable  $x_i$  brings truth value *true* by some truth assignment to clause  $C_j$ , while having  $\phi(c_j v_i) = 2$  models that  $x_i$  brings truth value *false* to  $C_j$ . The fact that not all formula edges incident to some clause vertex  $c_j$  can be assigned the same colour by  $\phi$  thus models that  $C_j$  is considered satisfied by a truth assignment if and only if it has variables with distinct truth values. The fact that all formula edges incident to some variable vertex  $v_i$  must be assigned the same colour by  $\phi$  thus models that  $x_i$  brings the same truth value to all clauses that contain it, by a truth assignment. From this, it should be clear that we can derive a truth assignment to the variables of  $F$  satisfying all clauses in a nae way, from a h.i. 2-edge-colouring of  $G$ . Conversely, it is not too complicated to check, due to the previous lemmas and arguments, that a truth assignment to the variables of  $F$  satisfying all clauses in a nae way can be turned into a h.i. 2-edge-colouring of  $G$ . Thus, the equivalence holds.  $\square$

Since forbidding gadgets are trees, attaching (as done above) a tree to a bipartite graph results in a bipartite graph, and we start from a bipartite graph in the reduction above, it can be checked that, indeed, the reduced graphs we construct in the proof are bipartite. Thus, Theorem 5.4 indeed holds for bipartite graphs. Also, as mentioned in the proof, the fact that our reduction is performed from instances of MONOTONE NOT-ALL-EQUAL 3SAT where variables appear in exactly four distinct clauses each, also implies that Theorem 5.4 remains true when restricted to graphs of bounded maximum degree, which complements upcoming Theorem 5.5.

## 5.2. Polynomial-time algorithms

In the previous section we mentioned that, in general, having bounded maximum degree in a graph  $G$  does not guarantee that  $\chi_{\text{h.i.}}(G)$  is easy to determine. In the next result, we prove this holds true under the additional assumption that  $G$  has bounded tree-width  $\text{tw}(G)$ . In other words, we prove that determining  $\chi_{\text{h.i.}}(G)$  is an FPT problem when parameterised by  $\Delta(G)$  and  $\text{tw}(G)$ .

The proof is based on monadic second-order ( $\text{MSO}_2$ ) logic, which allows quantification over vertices, edges, subsets of vertices, and subsets of edges. We adhere to the syntax and semantics defined by Cygan *et al.* in [10] to describe our formulas. In particular, an atomic formula we will use is  $\mathbf{inc}(u, e)$ , which, in a graph  $G$  with a vertex  $u$  and an edge  $e$ , is true if and only if  $e$  is incident to  $u$ . Recall that the celebrated Courcelle's Theorem [11] ensures the existence of an algorithm that, given a graph  $G$  and an  $\text{MSO}_2$ -logic formula, checks if  $G$  satisfies that formula in linear FPT time w.r.t. the tree-width of  $G$  and the size of the formula.

**Theorem 5.5.** *There is an algorithm that verifies if any graph  $G$  with order  $n$  can be decomposed into  $k$  h.i. graphs in time  $f(k, \Delta(G), \text{tw}(G)) \cdot n$ , for some computable function  $f$ .*

*Proof.* The problem is shown to be definable by an  $\text{MSO}_2$ -logic formula whose size depends on both  $k$  and a constant  $\Delta$ , so that the result follows from Courcelle's Theorem on graphs with maximum degree at most  $\Delta$ .

First, we introduce two auxiliary formulas:  $\mathbf{adj}(u, v, E')$  which verifies whether some edge  $uv$  belongs to some edge set  $E'$ , and  $\mathbf{deg}_i(u, E')$  which verifies whether some vertex  $u$  is incident to exactly  $i$  edges of  $E'$ , where  $i \leq \Delta(G)$  is a constant. The first one is defined as

$$\mathbf{adj}(u, v, E') = (u \neq v) \wedge \exists_{e \in E'} (\mathbf{inc}(u, e) \wedge \mathbf{inc}(v, e)),$$

while the second one is defined as

$$\mathbf{deg}_i(u, E') = \exists_{e_1, \dots, e_i \in E'} \left( \left( \bigwedge_{1 \leq j_1 < j_2 \leq i} e_{j_1} \neq e_{j_2} \right) \wedge \left( \bigwedge_{1 \leq j \leq i} \mathbf{inc}(u, e_j) \right) \wedge \left( \forall_{e_{i+1} \in E'} \left( \left( \bigwedge_{1 \leq j \leq i} e_j \neq e_{i+1} \right) \Rightarrow \neg \mathbf{inc}(u, e_{i+1}) \right) \right) \right).$$

Now, consider the formula

$$\mathbf{Decomposable} = \exists_{E_1, \dots, E_k \subseteq E} \left( \mathbf{Partition}(E_1, \dots, E_k) \wedge \bigwedge_{1 \leq i \leq k} \mathbf{HI}(E_i) \right),$$

where  $\mathbf{Partition}(E_1, \dots, E_k)$  is a formula checking whether a collection  $(E_1, \dots, E_k)$  of sets is indeed a partition of the edge set of  $G$ , and  $\mathbf{HI}(E')$  is a formula that checks whether

$G(V, E')$  is h.i. These two formulas are defined as

$$\mathbf{Partition}(E_1, \dots, E_k) = \forall_{e \in E} \left( \left( \bigvee_{1 \leq i \leq k} e \in E_i \right) \wedge \left( \bigwedge_{1 \leq i < j \leq k} \neg(e \in E_i \wedge e \in E_j) \right) \right)$$

and

$$\begin{aligned} \mathbf{HI}(E') &= \forall_{u, v \in V} \left( \left( (u \neq v) \wedge \bigvee_{1 \leq i \leq \Delta} (\mathbf{deg}_i(u, E') \wedge \mathbf{deg}_i(v, E')) \right) \right. \\ &\quad \left. \Rightarrow \neg \left( \exists_{w \in V} (\mathbf{adj}(u, w, E') \wedge \mathbf{adj}(v, w, E')) \right) \right). \end{aligned}$$

By the definitions of the above formulas,  $G \models \mathbf{Decomposable}$  if and only if  $G$  has a decomposition into  $k$  h.i. graphs. Since the size of the formula only depends on  $k$  and  $\Delta$ , by Courcelle's Theorem there exists an algorithm that verifies if  $G$  can be decomposed into  $k$  h.i. graphs in time  $f(k, \Delta, \text{tw}(G)) \cdot n$ , where  $f$  is a computable function.  $\square$

A particular, notable case is that of trees, since their tree-width is 1.

**Corollary 5.6.** *For any tree  $T$  with fixed maximum degree, we can determine  $\chi_{\text{h.i.}}(T)$  in linear time.*

Finally, since  $\chi_{\text{h.i.}}(G) \leq \Delta(G) + 1$  holds in any graph  $G$  (recall Theorem 2.2), the algorithm of Theorem 5.5 can be used to compute the exact value of  $\chi_{\text{h.i.}}(G)$ .

**Corollary 5.7.** *There is an algorithm that, given a graph  $G$  with order  $n$ , computes  $\chi_{\text{h.i.}}(G)$  in time  $g(\Delta(G), \text{tw}(G)) \cdot n$ , for some computable function  $g$ .*

## 6. Conclusion

In this work, we have introduced and studied the notion of h.i. decompositions. Our first goal was, in the line of previous l.i. decompositions, to introduce a decompositional point of view over a variant of the 1-2-3 Conjecture in [7]. Another one was, still in the line of l.i. decompositions, to wonder about the similarities and discrepancies when considering another notion of irregularity, namely that of h.i. graphs introduced by Alavi, Chartrand, Chung, Erdős, Graham and Oellermann. Throughout, we did our best to provide results and observations allowing for a general understanding of h.i. decompositions and the related parameter  $\chi_{\text{h.i.}}$ , but also to get a better catch in more restricted contexts (such as for complete bipartite graphs and complete graphs).

Our understanding of our new notions, and the results we came up with, lead to open questions and problems which we believe could be worth investigating further; namely:

- Through Theorem 2.2 and Observation 2.7, we established that, for a graph  $G$ , the maximum magnitude of  $\chi_{\text{h.i.}}(G)$  is of order about  $\Delta(G)$ . More specifically, we observed through Theorem 2.3 that  $\chi_{\text{h.i.}}(G)$  can reach the value  $\Delta(G) + 1$ , but this observation was made in the very specific context where  $\Delta(G) = 2$ . This leads us to wonder whether we can have  $\chi_{\text{h.i.}}(G) = \Delta(G) + 1$  for graphs  $G$  with  $\Delta(G) \geq 3$ , and we think this is an appealing question. On the one hand, as  $\Delta(G)$  increases, there should be more decomposition possibilities for  $G$ . However, on the other hand, previous works, such as [3], have established that h.i. graphs with large maximum degree tend to be very large; so having large maximum degree for a graph  $G$  is somewhat helpful w.r.t. h.i. decompositions only when  $|V(G)|$  is large enough.

- Regarding this matter, as a starting point, we wonder about the more peculiar case where  $\Delta(G) = 3$ . An issue we encountered, is, as we discussed in Section 2, that we only need to focus on class-2 subcubic graphs, a class of graphs that is not obvious to comprehend in general, even when adding a 2-connectivity constraint (so that we fall into the well-studied class of so-called *snarks*).
- Regarding our results in Section 3, recall that we have established a rather good estimate over the parameter  $\chi_{\text{h.i.}}$  for complete bipartite graphs  $K_{n,m}$  (through Theorems 3.8 and 3.7), while we were able to determine its exact value only for specific complete bipartite graphs, when  $n \in \{2, 3\}$  (recall Corollaries 3.10 and 3.11). These last two corollaries actually highlight that our approach in the proof of Theorem 3.7 should indeed be the way to go: that is, provide tight results for “small” complete bipartite graphs  $K_{n,m}$  (*i.e.*, assuming  $n \leq m$ , where  $m$  is somewhat close to  $n$ ), and then prove that every “larger” one (*i.e.*, with  $n$  and  $m$  being more distant) decomposes into a well-chosen combination of the smaller pieces. It seems to us, however, that the notion of “small” is a function of  $n$ , which makes it unclear how a nice argument should go. Maybe the numbers provided in the statement of Theorem 3.7 provide a good hint on this question.
- From Theorem 5.4, we already get that determining  $\chi_{\text{h.i.}}(G)$  for a given graph  $G$  is hard (unless  $\text{P}=\text{NP}$ ). However, our result is derived specifically from the hardness of determining whether a graph  $G$  admits a h.i. 2-edge-colouring. Consequently, we wonder whether there is a nice way to prove that this also holds for h.i.  $k$ -edge-colourings, for every fixed  $k \geq 3$ . Proving this is true would make our result more convincing.
- Using Courcelle’s Theorem to prove Theorem 5.5 guarantees  $\chi_{\text{h.i.}}(G)$  can be determined in linear time for graphs  $G$  with bounded tree-width and bounded maximum degree. The running time of a corresponding algorithm, however, while still linear, would be very bad (in particular, the hidden constant is, in brief, a tower of exponentials) and we wonder whether better algorithms can be designed, for instance using a dynamic programming approach. In particular, an appealing setting for this context is that of trees, *i.e.*, graphs with tree-width 1.
- In the very same line, recall that Theorem 5.4 holds for graphs with bounded maximum degree, so unless  $\text{P}=\text{NP}$  we cannot drop the tree-width requirement from Theorem 5.5. One can naturally wonder whether there are other (combinations of) parameters catching the tractability of the problem.

## References

- [1] A. Ali, G. Chartrand, P. Zhang. *Irregularity in Graphs*, Springer Nature, 2021.
- [2] Y. Alavi, F. Buckley, M. Shamula, S. Ruiz. Highly irregular  $m$ -chromatic graphs. *Discrete Mathematics*, 72:3–13, 1988.
- [3] Y. Alavi, G. Chartrand, F.R.K. Chung, P. Erdős, R.L. Graham, O.R. Oellermann. Highly irregular graph. *Journal of Graph Theory*, 11(2):235–249, 1987.
- [4] O. Baudon, J. Bensmail, T. Davot, H. Hocquard, J. Przybyło, M. Senhaji, É. Sopena, M. Woźniak. A general decomposition theory for the 1-2-3 Conjecture and locally irregular decompositions. *Discrete Mathematics and Theoretical Computer Science*, 21(1), 2019, #2.

- [5] O. Baudon, J. Bensmail, J. Przybyło, M. Woźniak. On decomposing regular graphs into locally irregular subgraphs. *European Journal of Combinatorics*, 49:90–104, 2015.
- [6] O. Baudon, J. Bensmail, É. Sopena. On the complexity of determining the irregular chromatic index of a graph. *Journal of Discrete Algorithms*, 30:113–127, 2015.
- [7] J. Bensmail, B. Li, B. Li. An injective version of the 1-2-3 Conjecture. *Graphs and Combinatorics*, 37:281–311, 2021.
- [8] J. Bensmail, M. Merker, C. Thomassen. Decomposing graphs into a constant number of locally irregular subgraphs. *European Journal of Combinatorics*, 60:124–134, 2017.
- [9] G. Chartrand, M.S. Jacobson, J. Lehel, O.R. Oellermann, S. Ruiz, F. Saba. Irregular networks. *Congressus Numerantium*, 64:197–210, 1988.
- [10] F. Cygan, F.V. Fomin, Ł. Kowalik, D. Lokshtanov, D. Marx, M. Pilipczuk, M. Pilipczuk, and S. Saurabh. *Parameterized Algorithms*, Springer, 2015.
- [11] B. Courcelle. The monadic second-order logic of graphs. I. Recognizable sets of finite graphs. *Information and Computation*, 85(1), 12–75, 1990.
- [12] A. Darmann, J. Döcker. On a simple hard variant of NOT-ALL-EQUAL 3-SAT. *Theoretical Computer Science*, 815:147–152, 2020.
- [13] M. Karoński, T. Łuczak, A. Thomason. Edge weights and vertex colours. *Journal of Combinatorial Theory, Series B*, 91:151–157, 2004.
- [14] R. Keusch. A Solution to the 1-2-3 Conjecture. *Journal of Combinatorial Theory, Series B*, 166:183–202, 2024.
- [15] D. Leven, Z. Galil. NP Completeness of Finding the Chromatic Index of Regular Graphs. *Journal of Algorithms*, 4:35–44, 1983.
- [16] H. Lei, X. Lian, Y. Shi, R. Zhao. Graph Classes with Locally Irregular Chromatic Index at most 4. *Journal of Optimization Theory and Applications*, 195:903–918, 2022.
- [17] C.N. Lintzmayer, G.O. Mota, M. Sambinelli. Decomposing split graphs into locally irregular graphs. *Electronic Notes in Theoretical Computer Science*, 346:603–612, 2019.
- [18] B. Lužar, M. Maceková, S. Rindošová, R. Soták, K. Sroková, K. Štorgel. Locally irregular edge-coloring of subcubic graphs. *Discrete Applied Mathematics*, 339:136–148, 2023.
- [19] B. Lužar, J. Przybyło, R. Soták. New bounds for locally irregular chromatic index of bipartite and subcubic graphs. *Journal of Combinatorial Optimization*, 36(4):1425–1438, 2018.
- [20] Z. Majcher, J. Michael. Highly irregular graphs with extreme numbers of edges. *Discrete Mathematics*, 164:237–242, 1997.
- [21] Z. Majcher, J. Michael. Degree sequences of highly irregular graphs. *Discrete Mathematics*, 164:225–236, 1997.
- [22] J. Przybyło. On decomposing graphs of large minimum degree into locally irregular subgraphs. *Electronic Journal of Combinatorics*, 23(2):#P2.31, 2016.

- [23] J. Przybyło. Decomposability of regular graphs to 4 locally irregular subgraphs. *Applied Mathematics and Computation*, 480:128916, 2024.
- [24] J. Sedlar, R. Škrekovski. Remarks on the Local Irregularity Conjecture. *Mathematics*, 9(24):3209, 2021.
- [25] J. Sedlar, R. Škrekovski. A note on the locally irregular edge colorings of cacti. *Discrete Mathematics Letters*, 11:1–6, 2023.
- [26] V.G. Vizing. On an estimate of the chromatic class of a  $p$ -graph. *Discret Analiz*, 3:25–30, 1964.