



HAL
open science

1-Extendability of Independent Sets

Pierre Bergé, Anthony Busson, Carl Feghali, Rémi Watrigant

► **To cite this version:**

Pierre Bergé, Anthony Busson, Carl Feghali, Rémi Watrigant. 1-Extendability of Independent Sets. IWOCA 2022, Jun 2022, Trier, Germany. pp.757-781, 10.1007/s00453-023-01138-8 . hal-04660049

HAL Id: hal-04660049

<https://hal.science/hal-04660049v1>

Submitted on 12 Dec 2024

HAL is a multi-disciplinary open access archive for the deposit and dissemination of scientific research documents, whether they are published or not. The documents may come from teaching and research institutions in France or abroad, or from public or private research centers.

L'archive ouverte pluridisciplinaire **HAL**, est destinée au dépôt et à la diffusion de documents scientifiques de niveau recherche, publiés ou non, émanant des établissements d'enseignement et de recherche français ou étrangers, des laboratoires publics ou privés.

1-extendability of independent sets

Pierre Bergé

University of Clermont Auvergne

Anthony Busson

Claude Bernard University Lyon 1

Carl Feghali

École Normale Supérieure de Lyon

Rémi Watrigant (✉ remi.watrigant@ens-lyon.fr)

Claude Bernard University Lyon 1

Research Article

Keywords: 1-extendable graphs, B-graphs, independent set

Posted Date: October 11th, 2022

DOI: <https://doi.org/10.21203/rs.3.rs-2142423/v1>

License:  This work is licensed under a Creative Commons Attribution 4.0 International License.

[Read Full License](#)

1-Extendability of independent sets

Pierre Bergé^{1,2}, Anthony Busson¹, Carl Feghali¹ and Rémi Watrigant¹

¹Univ Lyon, CNRS, ENS de Lyon, Université Claude Bernard
Lyon 1, LIP UMR5668, France.

²Université Clermont Auvergne, CNRS, LIMOS UMR 6158,
Clermont-Ferrand France.

Contributing authors: pierre.berge@uca.fr;
anthony.busson@ens-lyon.fr; carl.feghali@ens-lyon.fr;
remi.watrigant@ens-lyon.fr;

Abstract

In the 70s, Berge introduced 1-extendable graphs (also called B-graphs), which are graphs where every vertex belongs to a maximum independent set. Motivated by an application in the design of wireless networks, we study the computational complexity of **1-EXTENDABILITY**, the problem of deciding whether a graph is 1-extendable. We show that, in general, **1-EXTENDABILITY** cannot be solved in $2^{o(n)}$ time assuming the Exponential Time Hypothesis, where n is the number of vertices of the input graph, and that it remains NP-hard in subcubic planar graphs and in unit disk graphs (which is a natural model for wireless networks). Although **1-EXTENDABILITY** seems to be very close to the problem of finding an independent set of maximum size (*a.k.a.* **MAXIMUM INDEPENDENT SET**), we show that, interestingly, there exist 1-extendable graphs for which **MAXIMUM INDEPENDENT SET** is NP-hard. Finally, we investigate a parameterized version of **1-EXTENDABILITY**.

Keywords: 1-extendable graphs, B-graphs, independent set

1 Introduction and Motivation

1.1 Definitions and Related Work

Understanding the structure of independent sets is among the most studied subjects in algorithmics and graph theory. Finding graph classes where a maximum independent set (MIS for short) can be found efficiently is an important theoretical and practical problem. In 1970, [Plummer \(1970\)](#) defined the class of well-covered graphs, which are graphs where every independent set which is maximal for inclusion is also an MIS. In other words, they are exactly the graphs for which the greedy algorithm always returns an optimal solution. Well-covered graphs were studied mostly from an algorithmic perspective: their recognition was proven coNP-hard [Chvátal and Slater \(1993\)](#); [Sankaranarayana and Stewart \(1992\)](#) in general graphs, but polynomial-time solvable for claw-free graphs [Tankus and Tarsi \(1996\)](#), and perfect graphs of bounded clique number [Dean and Zito \(1994\)](#).

A related notion, introduced by [Berge \(1981\)](#), is the definition of B-graphs, which are those graphs where every vertex belongs to an MIS. B-graphs were mostly introduced in order to study well-covered graphs [Ravindra \(1976, 1977\)](#). Later, the notion of B-graphs was generalized to that of k -extendable graphs [Dean and Zito \(1994\)](#): a graph is k -extendable, for a positive integer k , if every independent set of size (exactly) k is contained in an MIS. Thus, B-graphs are exactly the 1-extendable graphs and a graph is well-covered if and only if (iff) it is k -extendable for every $k \in \{1, 2, \dots, \alpha(G)\}$, where $\alpha(G)$ denotes the size of an MIS of G . Dean and Zito [Dean and Zito \(1994\)](#) obtained a number of results on 1-extendable graphs; for instance, they proved that a bipartite graph is 1-extendable iff it admits a perfect matching and, hence, bipartite 1-extendable graphs can be recognized in polynomial time. Recently, certain structural properties of k -extendable graphs were stated [Angaleeswari et al \(2015, 2016\)](#).

We should note that the notion of k -extendability was also studied in the context of maximum matchings [Plummer \(1980, 1994\)](#). Recently, it was shown that the recognition of (matching) k -extendable graphs is co-NP-complete [Hackfeld and Koster \(2018\)](#).

In the remainder, B-graphs will be called 1-extendable graphs, as it is the terminology used by the most recent papers on the topic. In this article, our objective is to determine the computational complexity of the recognition of 1-extendable graphs. This question is not only motivated by the state of the art described above but also by an application on Wi-Fi networks.

1.2 CSMA/CA network and 1-extendability

Indeed, 1-extendable graphs play an important role in the performance of CSMA/CA (Carrier Sense Multiple Access / Collision Avoidance) networks. CSMA/CA is the mechanism used by the nodes to access the radio channel in many wireless network technologies. It aims to prevent collisions, which

happens when several nodes transmit at the same time thereby producing harmful interference that may cause transmissions losses. Basically, it is a listen-before-talk mechanism where a potential transmitter listens to the radio channel for a certain period of time, and transmits if the channel was sensed as idle during this period.

Graphs stand as a natural model for CSMA/CA wireless networks. Two vertices, *i.e.* nodes of the CSMA/CA network, are adjacent if the two corresponding nodes are able to detect the transmissions from each others. If we assume that all nodes are on the same channel, transmissions from two vertices can occur in parallel iff they are not adjacent. A set of instantaneous transmitters is thus an independent set of the graph.

This graph, also named *conflict graph* in the literature, is used to evaluate the network performance. The performance parameter that is often computed is the *throughput* of each vertex, *i.e.* the number of bits per second that a vertex is able to send. The throughput of a vertex is strongly correlated to the proportion of time this vertex is transmitting. We denote by p_v this quantity for the vertex $v \in V(G)$. If we neglect the network protocol headers and transmission errors, the throughput of vertex v may be considered as proportional to p_v . The first formal work that characterized p_v has been developed in Liew et al (2010). It was shown that, under saturation condition, p_v is given by:

$$p_v = \frac{\sum_{S \in \mathcal{S}(G): v \in S} \theta^{|S|}}{\sum_{S \in \mathcal{S}(G)} \theta^{|S|}}, \quad (1)$$

where θ is the ratio between transmission and listen phase durations and $\mathcal{S}(G)$ is the collection of independent sets of G . When θ tends to infinity, p_v tends to the number of MISs of G containing v ($\#_v \alpha(G)$) divided by the total number $\# \alpha(G)$ of MISs of G :

$$\lim_{\theta \rightarrow +\infty} p_v = \frac{\#_v \alpha(G)}{\# \alpha(G)} \quad (2)$$

In practice, the value of θ tends to be large to ensure an efficient channel use. In Wi-Fi networks for instance, typical values of θ then ranges from 20 to 100 depending on the transmission parameters. With such values, a node/vertex that does not belong to any MIS will experience a very low throughput. In Fig. 1, we show the throughput obtained in a Wi-Fi network for paths on 4 and 5 vertices using the network simulator ns-3 ns3 (2022). The 5-vertex path is not 1-extendable, and we can observe that the two vertices that do not belong to any MIS are in starvation: they admit a very low throughput. In the 4-vertex path, there is no starvation as all vertices belong to at least one MIS.

The fact, for each vertex, of belonging or not to an MIS is thus of prior importance to ensure a minimal fairness between the vertices and to avoid starvation. CSMA/CA networks where the parameter θ is large must thus be designed in such a way that the resulting conflict graph is 1-extendable.

4 1-Extendability of independent sets

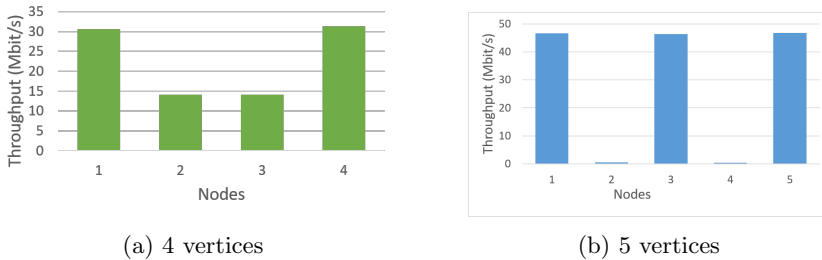

Fig. 1: Wi-Fi network simulated with ns-3 for paths on 4 and 5 vertices. The simulation parameters are: Wi-Fi 6 (IEEE 802.11ax) with a fixed MCS (He MCS=5), packet size=1024 bytes, aggregation is enable with a maximum of 16 aggregated frame. The traffic is saturated.

1.3 Contribution

Most of the outcomes of this paper concern the complexity of 1-EXTENDABILITY, the problem of deciding whether an input graph is 1-extendable. First, we focus on the relationship between MAXIMUM INDEPENDENT SET and 1-EXTENDABILITY. We observe that any polynomial-time algorithm for MAXIMUM INDEPENDENT SET on some hereditary family of graphs \mathcal{C} provides us with a polynomial-time algorithm for 1-EXTENDABILITY on \mathcal{C} . Based on this result, we could imagine that, perhaps, MAXIMUM INDEPENDENT SET and 1-EXTENDABILITY are equivalent problems in terms of complexity. However, we show that MAXIMUM INDEPENDENT SET is NP-hard on a certain subfamily of 1-extendable graphs (Theorem 2). This result highlights a gap for the complexity of these two problems.

We provide a linear reduction which implies, under the Exponential Time Hypothesis (ETH) that 1-EXTENDABILITY cannot be solved in time $2^{o(n)}$ on an n -vertex input graph (Corollary 1).

Second, we establish the NP-hardness of 1-EXTENDABILITY on certain families of graphs. We prove that the problem is NP-hard in planar subcubic graphs (Theorem 5) and in unit disk graphs (Theorem 7), a natural model for CSMA/CA networks.

Eventually, we focus on a parameterized version of 1-EXTENDABILITY, where we ask whether every vertex belongs to an independent set of size at least some parameter k . We show that this problem, PARAM-1-EXTENDABILITY, is W[1]-hard (Theorem 8). Nevertheless, it admits a polynomial kernel if restricted to planar graphs or K_r -free graphs for fixed $r > 0$ (Corollary 2).

1.4 Organization of the paper

Section 2 is dedicated to the notation, definitions and some basic results; in particular, we explore the relationship between the MAXIMUM INDEPENDENT SET and 1-EXTENDABILITY problems. In Section 3, we study three graph transformations and their impact on the 1-extendability property. In Section 4,

we show that 1-EXTENDABILITY cannot be solved in time $2^{o(n)}$ on n -vertex graphs unless the ETH is false. We also prove that 1-EXTENDABILITY remains NP-hard in planar graphs of maximum degree 3 and in unit disk graphs. Then, Section 5 presents the parameterized version PARAM-1-EXTENDABILITY and the results associated with it. We conclude and give several open questions in Section 6.

2 Notation and Basic Results

2.1 Notation and definitions

For a positive integer k , we write $[k] = \{1, \dots, k\}$. In this paper, all graphs are simple, unweighted and undirected. We denote by $V(G)$ the vertex set of a graph G and by $E(G)$ its edge set. Edges $(u, v) \in E(G)$ can sometimes be denoted by uv to improve readability. When the identity of the graph considered is clear, we set $n = |V(G)|$ and $m = |E(G)|$. For a vertex $v \in V(G)$, we denote by $N_G(v)$ its set of neighbors (we will sometimes omit the subscript if G is clear from the context). Let $d(v)$ be the degree of v , *i.e.* $d(v) = |N(v)|$. For a subset $R \subseteq V(G)$, let $G[R]$ be the subgraph of G induced by R . A family of graphs \mathcal{C} is called *hereditary* if, for every graph $G \in \mathcal{C}$, every induced subgraph of G also belongs to \mathcal{C} . An ℓ -vertex path is denoted by P_ℓ . A *clique cover* of a graph G is a partition of $V(G)$ into sets C_1, \dots, C_q such that $G[C_i]$ is a clique for every $i \in [q]$. A set of pairwise non-adjacent vertices in a graph is called an *independent set*. A *maximum independent set* (MIS) is an independent set of maximum size. We denote by $\alpha(G)$ the size of an MIS of G . The decision problem of finding an independent set of size at least $k \geq 1$ in a graph G is called MAXIMUM INDEPENDENT SET. A graph G is *1-extendable* Berge (1981) if, for every $u \in V(G)$, there is an MIS S of G such that $u \in S$.

The subject of this paper is to investigate the computational complexity of the following decision problem.

1-EXTENDABILITY

Input: Graph G

Question: Does every vertex of G belong to an MIS of G ?

An *embedding* of a graph G is a representation of G in the plane, where vertices are points in the plane and edges are curves which connect their two endpoints. A *plane embedding* of G is an embedding of G where no two edges cross. A graph G is *planar* if it admits a plane embedding.

A *parameterized problem* is a decision problem where an integer (called the parameter) is associated to every instance. A Fixed-Parameter Tractable (FPT) algorithm is an algorithm deciding whether an instance of a parameterized problem is positive in time $f(k)n^{O(1)}$, where f is a computable function, n is the size of the instance, and k is the parameter of the instance. The W -hierarchy allows to rule out the existence of FPT algorithms for some problems: proving that a parameterized problem is $W[1]$ -hard implies that it is

unlikely to admit an FPT algorithm. A *kernel* for a parameterized problem is a polynomial-time algorithm which transforms an instance x with parameter k into an instance x' with parameter k' such that (i) x is positive iff x' is positive (ii) $k' \leq k$, and (iii) $|x'| \leq f(k)$, where f is a computable function called the *size* of the kernel. If f is a polynomial, we say that it is a *polynomial kernel*. For more details about parameterized algorithms, we refer the reader to the textbook of Cygan et al (2015).

2.2 Links between 1-Extendability and Maximum Independent Set

In this section, we investigate to what extent the problems 1-EXTENDABILITY and MAXIMUM INDEPENDENT SET are close to each other. We show a ‘‘Turing equivalence’’ of the two problems in general graphs. More precisely, we prove that solving 1-EXTENDABILITY on an input graph G can be done by solving MAXIMUM INDEPENDENT SET on several induced subgraphs of G , while solving MAXIMUM INDEPENDENT SET on an input graph G can be done by solving 1-EXTENDABILITY on several induced supergraphs of G .

Solving 1-extendability using Maximum Independent Set.

The idea relies on the following lemma, whose straightforward proof is left to the reader.

Lemma 1 Let G be a graph, and k be a non-negative integer. Then a vertex v of G is contained in an independent set of G of size k iff $G[V(G) \setminus N(v)]$ contains an independent set of size k .

Consequently, a graph G is 1-extendable iff, for every $v \in V(G)$, the MIS size in $G[V(G) \setminus N(v)]$ is still $\alpha(G)$. This characterization allows 1-EXTENDABILITY to inherit many positive results from MAXIMUM INDEPENDENT SET. In particular, it implies that 1-EXTENDABILITY is polynomial-time solvable in any hereditary class where MAXIMUM INDEPENDENT SET is polynomial-time solvable. This is for instance the case for perfect graphs, P_6 -free graphs Grzesik et al (2019), chordal graphs and claw-free graphs. Moreover, it is Fixed-Parameter Tractable (FPT) when parameterized by the tree-width or even the clique-width of the input graph. As we will see later in Section 5, this lemma can also be used to transfer more positive FPT results for a parameterized version of 1-EXTENDABILITY.

Solving Maximum Independent Set using 1-extendability.

The converse of Lemma 1 does not appear to be as straightforward, and we leave as open whether solving 1-EXTENDABILITY in a hereditary graph class \mathcal{C} in polynomial-time allows one to solve MAXIMUM INDEPENDENT SET in \mathcal{C} in polynomial-time. We can show, however, that this is true if the class satisfies much more conditions than just being hereditary.

Let $G = (V, E)$ be a graph and $r \leq |V|$ be a non-negative integer. Let G_r^+ be the graph obtained from G by adding

- an independent set S of size $|V| - r$ to G ,
- for each vertex v of G , a new vertex π_v adjacent to v only, and
- all possible edges between S and the set $T = \{\pi_v : v \in V\}$.

Proposition 1 G_r^+ is 1-extendable iff $\alpha(G) = r$.

Proof Let $n = |V(G)|$. First observe that $\alpha(G_r^+) \geq n$, since T is an independent set. More precisely, by construction $\alpha(G_r^+) = \max\{n, n - r + \alpha(G)\}$.

Suppose that G_r^+ is 1-extendable. By definition, every vertex of S belongs to a MIS, and since all vertices of S have the same neighborhood, there must be a MIS I containing all vertices of S . Now, since the neighborhood of any vertex of S is T , it follows that G must contain an independent set of size $\alpha(G_r^+) - |S| \geq r$. But if G contains an independent set of size $r + 1$, then $\alpha(G_r^+) \geq n + 1$. However, for $v \in V(G)$, the non-neighborhood of π_v is of size $n - 1$, so π_v cannot belong to an independent set of size $n + 1$, contradicting the 1-extendability of G_r^+ . Thus, $\alpha(G) = r$.

Conversely, if $\alpha(G) = r$, then necessarily $\alpha(G_r^+) = n$. Let J be an independent set of size r in G . Observe that:

- for each vertex $v \in V(G)$, the set $\{v\} \cup \{\pi_u : u \in V(G) \setminus \{v\}\}$ is an independent set of size n ;
- T is an independent set of size n ;
- $S \cup J$ is an independent set of size n .

In brief, each vertex of G_r^+ is contained in a MIS, which concludes the proof. \square

The ETH [Impagliazzo and Paturi \(2001\)](#) states that no algorithm can decide whether a 3SAT formula on n variables is satisfiable in time $2^{o(n)}$. As 3-SAT, MAXIMUM INDEPENDENT SET is ETH-hard. Hence, based on Proposition 1, the same statement holds for 1-EXTENDABILITY.

Corollary 1 Testing whether an n -vertex graph is 1-extendable cannot be done in time $2^{o(n)}$ unless the ETH is false.

This lower bound is matched by the trivial brute-force algorithm which consists in enumerating all subsets of vertices, and testing whether all MISs cover the entire vertex set.

Another question related to the previous one is whether being 1-extendable helps finding a MIS. The next result suggests that this is unlikely, by showing that 1-EXTENDABILITY and MAXIMUM INDEPENDENT SET can sometimes behave very differently from a computational point of view.

Let $k \geq 1$ be an integer. The k -MULTICOLORED INDEPENDENT SET problem, asks, given a graph G whose vertex set can be partitioned into k

8 1-Extendability of independent sets

parts C_1, \dots, C_k each inducing a clique, whether G contains an independent set I such that $|I \cap C_i| = 1$ for each $i \in \{1, \dots, k\}$.

Theorem 2 MAXIMUM INDEPENDENT SET *remains NP-hard and W[1]-hard (parameterized by k) in 1-extendable graphs.*

Proof We reduce from k -MULTICOLORED INDEPENDENT SET which is well-known to be W[1]-hard [Cygan et al \(2015\)](#).

Let G be an instance of k -MULTICOLORED INDEPENDENT SET and let C_1, \dots, C_k be its k cliques. We construct a 1-extendable graph H from G such that G contains an independent set intersecting each C_i iff H contains an independent set of size $2k$.

To construct H , we take two copies G_1 and G_2 of G and add two new sets of vertices $P^1 = \{\pi_1^1, \dots, \pi_1^k\}$ and $P^2 = \{\pi_2^1, \dots, \pi_2^k\}$. We then add all possible edges between P^1 and P^2 and, for $i \in \{1, 2\}$ and $j \in \{1, \dots, k\}$, we make π_i^j adjacent to each vertex of C_i^j , where C_i^j denotes the j th clique of G_i . This completes the construction.

To see that H is 1-extendable, let A_1 and A_2 be maximum independents in G_1 and G_2 , respectively, and thus of size at most k . Note by construction that $\alpha(H) = k + \alpha(G)$. Thus, by construction again, we have that

- for each C_i^j and $x \in C_i^j$, the set $\{x\} \cup \{\pi_i^j : j \neq i\} \cup A_{3-i}$ is independent and of size $\alpha(H)$, and
- for each $i \in \{1, 2\}$, the set $P^i \cup A_{3-i}$ is independent and of size $\alpha(H)$,

and hence H is 1-extendable as needed.

Now, suppose G and thus G_1 has an independent set S of size k . Then $P^2 \cup S$ is an independent set of size $2k$ in H , as claimed.

Conversely, suppose H contains an independent set T of size $2k$. Let $F_1 = H[V(G_1) \cup P^1]$ and $F_2 = H[V(G_2) \cup P^2]$. Thus, $H = F_1 \cup F_2$. By construction, each F_i has independence number at most k , and thus T intersects each F_i on exactly k vertices. Hence, since there are all possible edges between P^1 and P^2 , T must intersect either G_1 or G_2 on k vertices, which in turn implies G has an independent set of size k , as required. This completes the proof. \square

3 Generic transformations

In this subsection, we present three graph transformations. They are related in some sense to the 1-extendability property: the first one produces a 1-extendable graph, the second one preserves the 1-extendability of the input graph and the third one decreases the maximum degree of the input graph and keeps it 1-extendable. These transformations (or similar ideas) will be used later in some reductions.

Given any graph G on n vertices, the transformation (T_1) returns a graph $G_{(1)}$ with $2n$ vertices which is not only 1-extendable but also admits G as an induced subgraph. The transformation (T_2) consists in 2-subdividing the edges of the graph. This operation preserves the 1-extendability: G is 1-extendable iff $G_{(2)}$ is too. Eventually, the transformation (T_3) produces a graph $G_{(3)}$

with maximum degree 3 which is 1-extendable if G is 1-extendable (note that the converse is not necessarily true). Transformations (T_2) and (T_3) are well-known, and provide a useful tool to prove hardness on some restricted graph classes. Furthermore, they preserve the planarity of the input graph.

Transformation (T_1) . The graph $G_{(1)}$ is obtained from G by adding a pendant vertex π_u for any $u \in V(G)$. The vertex π_u has degree one and is adjacent to u . The graph $G_{(1)}$ has thus $2n$ vertices and $m+n$ edges. One of its MISs is the set of pendant vertices $\{\pi_u : u \in V(G)\}$: we thus have $\alpha(G_{(1)}) = n = |V(G_{(1)})|/2$. This provides us with a trivial linear-size vertex-addition scheme to obtain a 1-extendable graph.

Lemma 2 For any graph G , $G_{(1)}$ is 1-extendable.

Proof The graph $G_{(1)}$ admits a clique cover of size $n = |V(G_{(1)})|/2$ consisting of all edges $u\pi_u$. As a consequence, the size of an MIS of $G_{(1)}$ is at most n . Furthermore, the set of pendant vertices forms an independent set of size n . We prove now that each vertex of $G_{(1)}$ belongs to an independent set of size n . We know it is already the case for pendant vertices. Let u be a non-pendant vertex of $G_{(1)}$. We fix the following n -sized set: $X_u = \{u\} \cup \{\pi_v : v \neq u\}$. All pendants are pairwise non-adjacent. Moreover, the neighborhood of $\{\pi_v : v \neq u\}$ contains exactly all non-pendant vertices, except u . Hence X_u is independent. In brief, every non-pendant vertex u also belongs to an MIS of $G_{(1)}$. \square

Transformation (T_2) . The graph $G_{(2)}$ is obtained from G by subdividing each of its edges an even number of times, *i.e.* each edge becomes an induced $P_{2\ell}$. In fact, (T_2) is a well-known graph transformation which provides, for instance, the proof that MAXIMUM INDEPENDENT SET remains *NP*-hard on graphs forbidding a fixed graph H as an induced subgraph, for any H different from a path or a subdivided claw [Aleksseev \(1982\)](#); [Poljak \(1974\)](#). This transformation preserves in some sense all independent sets of the input graph G .

Observation 3 ([Aleksseev \(1982\)](#); [Poljak \(1974\)](#)) Consider any MIS X' of $G_{(2)}$ and pick all its vertices $X \subsetneq X'$ which were already present in G , *i.e.* which do not belong to the subdivided edges. Then X is an MIS of the input graph G . Additionally, the set $X' \setminus X$ contains exactly half of the vertices formed by the subdivisions.

One can see that $G_{(2)}$ is planar iff G is planar (subdivisions do not influence planar embeddings). Moreover, (T_2) also preserves the 1-extendability of the input graph.

Lemma 3 G is 1-extendable iff $G_{(2)}$ is 1-extendable.

Proof We begin with some notation. For every vertex $u \in V(G)$, we denote by $\mathcal{R}[u]$ the set of vertices of $G_{(2)}$ which are (i) part of a subdivided edge incident to u and (ii) at even distance from u . We consider $u \in \mathcal{R}[u]$ as it is at distance zero from itself. We claim that u belongs to an MIS of G iff $\mathcal{R}[u]$ is a subset of an MIS of $G_{(2)}$.

If u is isolated, then it naturally belongs to all MISs of G . It stays isolated in $G_{(2)}$ and $\mathcal{R}[u] = \{u\}$, so our claim holds.

Assume that $|\mathcal{R}[u]| \geq 2$, i.e. u has at least one neighbor in G . On the one hand, let X be an MIS of G containing u . Let $\mathcal{R}[X] = \bigcup_{v \in X} \mathcal{R}[v]$. As X does not contain two adjacent vertices of G , then no adjacency appears in $\mathcal{R}[X]$. According to Observation 3, $\mathcal{R}[X]$ is an MIS of $G_{(2)}$ and $\mathcal{R}[u] \subseteq \mathcal{R}[X]$. On the other hand, let X' be an MIS of $G_{(2)}$ such that $\mathcal{R}[u] \subseteq X'$. According to Observation 3, as $u \in \mathcal{R}[u]$, there is an MIS of G containing u .

We can now prove that (T_2) preserves 1-extendability. If G is 1-extendable, then every set $\mathcal{R}[u]$, $u \in V(G)$, is a subset of some MIS of $G_{(2)}$. Observe that $V(G_{(2)}) = \bigcup_{u \in V(G)} \mathcal{R}[u]$, hence $G_{(2)}$ is 1-extendable. Conversely, if $G_{(2)}$ is 1-extendable, then every vertex of the original graph G appears within an MIS of $G_{(2)}$. By Observation 3, it belongs to at least one MIS of G . \square

Transformation (T_3) . The graph $G_{(3)}$ is obtained from G by replacing each of its vertices by a path in order to decrease the maximum degree of the graph. It is a folklore transformation which also works for other classical problems.

First, we replace each vertex $u \in V(G)$ by an induced odd path P_u of length $\ell = 2\Delta - 1$, where Δ is the maximum degree of G . We denote by u_1, \dots, u_ℓ the vertices of P_u . The vertex set of $G_{(3)}$ is $V(G_{(3)}) = \{u_1, \dots, u_\ell : u \in V(G)\}$. Second, let $Q_u \subseteq P_u$ be the set of vertices in P_u with odd index: $Q_u = \{u_{2i+1} : 0 \leq i \leq \Delta - 1\}$. For any $1 \leq i \leq d(u)$, we assign arbitrarily to each vertex u_{2i+1} of Q_u a neighbor $\rho(u_{2i+1}) \in V(G)$ of u , so that ρ is bijective. There are two types of edges in $G_{(3)}$:

- edges of induced paths P_u , $u \in V(G)$,
- edges $u_{2i+1}v_{2j+1}$ when $\rho(u_{2i+1}) = v$ and $\rho(v_{2j+1}) = u$.

In this way, the maximum degree $G_{(3)}$ is at most 3.

One may observe that Q_u is an independent set of P_u of maximum size Δ . This is the key property which allows us to show that this structure maintains the 1-extendability of the input graph.

Lemma 4 Let $n = |V(G)|$. We have $\alpha(G_{(3)}) = n(\Delta - 1) + \alpha(G)$. Moreover, if G is 1-extendable, then $G_{(3)}$ is 1-extendable.

Proof Let X be an MIS of G . We construct the following set in $G_{(3)}$:

$$X' = \left(\bigcup_{u \in X} Q_u \right) \cup \left(\bigcup_{u \notin X} P_u \setminus Q_u \right)$$

On the one hand, no vertex of $\bigcup_{u \notin X} P_u \setminus Q_u$ has a neighbor in X' . On the other hand, as X is an independent set, two vertices belonging respectively to Q_u and

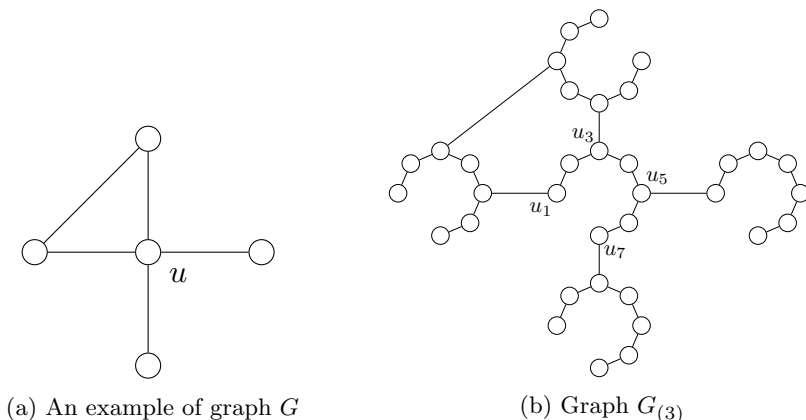

Fig. 2: Transformation (T_3) embedded in such a way that planarity holds.

$Q_v, u, v \in X$, are not adjacent. Therefore, X' is an independent set of $G_{(3)}$ of size $n(\Delta - 1) + \alpha(G)$. Now, assume that there is an independent set X^* of size at least $n(\Delta - 1) + \alpha(G) + 1$ in $G_{(3)}$. There are necessarily $\alpha(G) + 1$ paths P_u of $G_{(3)}$ which contain Δ vertices of X^* . The vertices $u \in V(G)$ satisfying this property must be pairwise non-adjacent, by definition of the edges $u_{2i+1}v_{2j+1}$. This yields a contradiction as we identify an independent set of G of size $\alpha(G) + 1$.

We prove the second part of the statement, by proving that every vertex $w \in G_{(3)}$ belongs to an MIS. If w is isolated, it belongs trivially to all MISs. If $w = u_{2i+1}$, $1 \leq i \leq \Delta - 1$, select an arbitrary MIS X_u of G containing u . We know that the set $X'_u = (\bigcup_{v \in X_u} Q_v) \cup (\bigcup_{v \notin X_u} P_v \setminus Q_v)$ is an MIS of $G_{(3)}$ and $w \in X'_u$. If $w = u_{2i}$ and is not isolated, then we select an arbitrary MIS Y_u of G containing one of its neighbors. The set $Y'_u = (\bigcup_{v \in Y_u} Q_v) \cup (\bigcup_{v \notin Y_u} P_v \setminus Q_v)$ is an MIS of $G_{(3)}$ and $w \in Y'_u$. \square

Assume graph G is planar. One can, by defining function ρ in a good way (Fig. 2), produce a graph $G_{(3)}$ which is still planar, according to Mohar (2001). Unfortunately, one can find examples of graphs G such that $G_{(3)}$ is 1-extendable while G is not. In other words, unlike (T_2) , transformation (T_3) does not produce an “equivalent” graph in terms of 1-extendability.

4 Hardness of 1-Extendability on subcubic planar graphs

The main goal of this section is to study the computational hardness of 1-EXTENDABILITY. We show that the problem is NP-hard in subcubic planar graphs and unit disk graphs.

4.1 Properties of the Garey-Johnson-Stockmeyer gadget

We now focus on restricted graph classes. Since our first motivation is the context of wireless networks, we investigate the complexity of the problem in

graphs modeling this kind of practical situations. Unit disk graphs is a natural graph class representing the conflict graph of wireless access points. As it is often the case when dealing with unit disk graphs, we first tackle the case of planar graphs of bounded degree. There exists a well-known gadget [Garey et al \(1976\)](#) which allows, for any graph G , to produce a planar graph G' with $O(n)$ vertices which is equivalent to G for the MAXIMUM INDEPENDENT SET problem. Concretely, G' is obtained by replacing each crossing appearing in an embedding of G in the plane by this gadget. In this article, we call it the *GJS-gadget* (for Garey-Johnson-Stockmeyer) and denote it by H_{GJS} (see Fig. 3a). Unfortunately, this trick does not work directly for 1-EXTENDABILITY. In order to make it work, our idea is to define a first reduction producing a non-planar graph, but where the crossings satisfy some interesting properties. Secondly, we use the previously mentioned gadget on this intermediate graph. Lastly, we use well-known tricks from the literature in order to reduce the maximum degree of the reduced graph, and to obtain a unit disk graph.

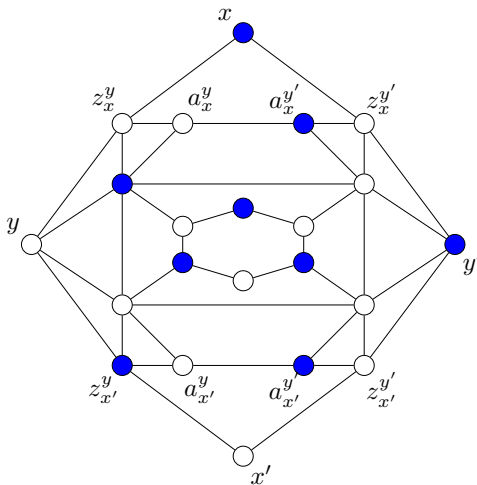

(a) A planar embedding of H_{GJS} together with an MIS of it (in blue)

	$ S \cap X = 0$	$= 1$	$= 2$
$ S \cap Y = 0$	7	8	8
$ S \cap Y = 1$	8	9	9
$ S \cap Y = 2$	7	8	9

(b) Largest MISs S of H_{GJS} containing a certain subset

Fig. 3: The GJS-gadget [Garey et al \(1976\)](#)

Description of the gadget. Fig. 3a represents H_{GJS} . Let $X = \{x, x'\}$, $Y = \{y, y'\}$, $Z = \{z_x^y, z_x^{y'}, z_{x'}^y, z_{x'}^{y'}\}$, $A = \{a_x^y, a_x^{y'}, a_{x'}^y, a_{x'}^{y'}\}$. We denote by b_x^y the common neighbor of z_x^y and a_x^y . Vertices $b_x^{y'}$, $b_{x'}^y$, $b_{x'}^{y'}$ are defined similarly. We fix $B = \{b_x^y, b_x^{y'}, b_{x'}^y, b_{x'}^{y'}\}$. The “ C_6 ” of H_{GJS} refers to the vertices which are not in sets X, Y, Z, A , and B . The size of the MIS of H_{GJS} is 9, according to [Garey et al \(1976\)](#). Blue vertices give an example of such MIS. Vertices x, x', y and y' are called the *endpoints* of H_{GJS} .

Fig. 3b indicates the sizes of a largest independent set S we obtain if we fix the intersection size with X and Y . For example, a largest independent set S which contains vertices x, y, y' is of size 8: one of them is such that it also contains $a_x^y, a_{x'}^y$, and 3 vertices from the C_6 . Another example: a largest independent set S containing exactly one vertex of X and one vertex of Y has size 9. The blue vertices of Fig. 3a form this kind of independent sets, with $S \cap X = \{x\}$ and $S \cap Y = \{y'\}$.

Consider an embedding of some graph G in the plane, and a crossing consisting of two edges uu' and vv' (as, for instance, in Fig. 4a, where $v_1v'_1$ plays the role of vv'). Replacing the crossing by a gadget means removing the edges uu' and vv' , adding a subgraph isomorphic to H_{GJS} , and adding the edges $vx, xy, yv', v'x'$, and $u'y$. By replacing each crossing of G by a gadget, we obtain a graph G_+ which is not only planar, but also equivalent to G for the MAXIMUM INDEPENDENT SET problem, in the sense that G contains an independent set of size k iff G_+ contains an independent set of size $k + 9\lambda$, where λ is the number of crossings in G Garey et al (1976). Fig. 4a shows an example of edge uu' of some graph G which is crossed by three other edges $v_1v'_1, v_2v'_2$, and $v_3v'_3$. In G_+ , these crossings become graphs isomorphic to H_{GJS} : they are denoted by H_1, H_2 , and H_3 respectively (Fig. 4b). Observe that, in Fig. 4b, gadgets H_1, H_2 , and H_3 are oriented in the same way (to avoid confusions), but it is not a mandatory requirement for the reduction. In other words, turning H_1 so that the neighbor of u (resp. the neighbors of v_1, v'_1) has degree four (resp. two) still would work.

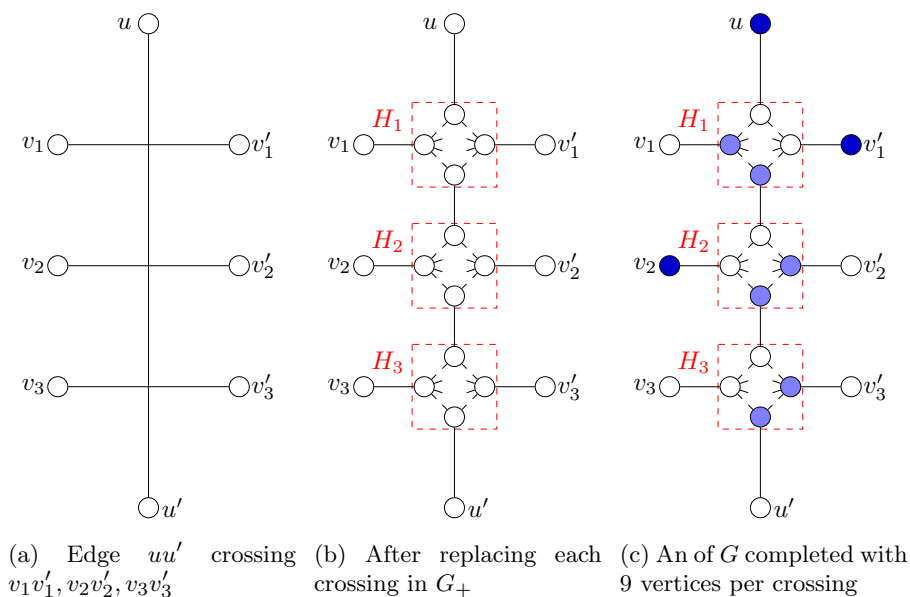

Fig. 4: Replacing each crossing by a GJS-gadget

As said previously, the size of an MIS G_+ is $\alpha(G) + 9\lambda$, where λ is the number of crossings in the planar embedding of G . The idea behind this statement is the following: if S is an independent set of G , then there exists an independent set S_+ of G_+ of size $|S| + 9\lambda$ which is made up of the vertices of S and 9 vertices per crossing. In Fig. 4c, the dark blue vertices represent an independent set S of G and the light blue ones are the endpoints of the gadgets, *i.e.* x, x', y, y' in Fig. 3, which belong to S_+ in G_+ . As S is independent, one can select, for each gadget, one vertex of $\{x, x'\}$ (and one vertex of $\{y, y'\}$) which is not adjacent to an element of S . We know that a largest independent set of H_{GJS} intersecting both $\{x, x'\}$ and $\{y, y'\}$ in exactly one element has size 9, which corresponds to the MIS size of H_{GJS} .

Lemma 5 (Graphs G and G_+ are equivalent for MAXIMUM INDEPENDENT SET Garey et al (1976)) Any MIS S of G can be completed into an MIS $S_+ \supseteq S$ of G_+ which contains exactly 9 vertices per crossing gadget. Conversely, given any MIS S^* of G_+ , the vertices of S^* which do not belong to a crossing gadget of G_+ form an MIS of G .

Preservation of 1-extendability. Our initial idea was to use the same gadget to transform every graph into a planar one which preserves the 1-extendability of G . Unfortunately, the property described above for MAXIMUM INDEPENDENT SET does not hold for 1-EXTENDABILITY. Indeed, one can find examples of graphs G such that G is 1-extendable and G_+ is not. For this reason, we state a weaker characterization involving the GJS-gadget. We will see further that this result is enough to prove that 1-EXTENDABILITY is NP-hard on planar graphs.

Proposition 4 Let G be a graph embedded in the plane and $uu' \in E(G)$. Let $v_1v'_1, v_2v'_2, \dots, v_\ell v'_\ell$ be the edges of G which cross uu' . Assume, for any $1 \leq i \leq \ell$, that there exists two MISs of G containing resp. u and u' but none of $\{v_i, v'_i\}$. Formally,

- there is an MIS $S_u^{(i)}$ of G such that $S_u^{(i)} \cap \{u, u', v_i, v'_i\} = \{u\}$,
- there is an MIS $S_{u'}^{(i)}$ of G such that $S_{u'}^{(i)} \cap \{u, u', v_i, v'_i\} = \{u'\}$,

Let G_+ be the graph obtained from G by replacing each crossing $\{uu', v_i v'_i\}$ with a GJS-gadget. Then, G_+ is 1-extendable iff G is 1-extendable.

Proof One direction is trivial. If G_+ is 1-extendable, then for any vertex u outside a crossing gadget, *i.e.* $u \in V(G)$, there is an MIS S^* of G_+ containing u . According to Lemma 5, one can obtain an MIS S of G containing u by removing the vertices of S belonging to the gadgets. In brief, for any $u \in V(G)$, there is an MIS of G containing u .

We suppose now that G is 1-extendable. This direction is trickier. We begin with a few notation. Let H_i be the crossing gadget H_{GJS} of $\{uu', v_i v'_i\}$ (see Fig. 4b), and x_i, x'_i, y_i, y'_i denote the endpoints of H_i , $1 \leq i \leq \ell$. We fix x_i as the closest one to u and y_i as the closest one to v_i . Our objective is to prove that each vertex of

gadgets H_i belongs to some MIS of G_+ . Indeed, we already know that the vertices of $V(G) \subseteq V(G_+)$ are contained in an MIS of G_+ , according to Lemma 5.

We pursue with an observation on the gadget H_{GJS} . Let $a \in \{x, x'\}$ and $b \in \{y, y'\}$. Observe that there is a single MIS of H_{GJS} whose intersection with $\{x, x'\}$ is $\{a\}$ and whose intersection with $\{y, y'\}$ is $\{b\}$. We denote by S_{ab} this set (for instance, the set $S_{xy'}$ is depicted in Fig. 3a). In addition, we have $S_{xy} \cup S_{xy'} \cup S_{x'y} \cup S_{x'y'} = V(H_{\text{GJS}})$. Consequently, in order to prove that G_+ is 1-extendable, it is sufficient to show that there are MISs of G_+ intersecting $\{x_i, x'_i, y_i, y'_i\}$ exactly in $\{x_i, y_i\}$, $\{x_i, y'_i\}$, $\{x'_i, y_i\}$, and $\{x'_i, y'_i\}$ respectively. The remainder consists in using both Lemma 5 and the assumptions on the MISs of G to put in evidence MISs of G_+ which intersect exactly these pairs. Let $S_u^{(i)}$ and $S_{u'}^{(i)}$ be as in the statement. We now show how to complete them in order to obtain these MISs.

Completion of $S_u^{(i)}$. According to Lemma 5, one can produce an MIS $S_{u,+}^{(i)}$ in G_+ which contains exactly 9 vertices per crossing gadget and $S_u^{(i)} \subseteq S_{u,+}^{(i)}$. All vertices x'_j , $1 \leq j \leq \ell$ necessarily belong to $S_{u,+}^{(i)}$. Indeed, x_1 is adjacent to u , so if we aim at picking up 9 vertices in H_1 , according to Fig. 3b, $x'_1 \in S_{u,+}^{(i)}$. Then, x_2 is adjacent to x'_1 , so x'_2 must be picked up, etc. In particular, $x'_i \in S_{u,+}^{(i)}$. Then, we know that neither v_i nor v'_i are in $S_u^{(i)}$. Therefore, $S_{u,+}^{(i)}$ may contain either y_i or y'_i or both of them. But, it suffices to pick up exactly one of them to have $|H_i \cap S_{u,+}^{(i)}| = 9$. Moreover, selecting either y_i or y'_i when we produce $S_{u,+}^{(i)}$ does not influence the adjacency over the other crossing gadgets or the rest of the graph. Hence, there are two MISs of G_+ : one intersecting exactly $\{x'_i, y_i\}$ and another intersecting exactly $\{x'_i, y'_i\}$.

Completion of $S_{u'}^{(i)}$. The symmetrical analysis provides us with two MISs of G_+ intersecting the endpoints of H_i on exactly $\{x_i, y_i\}$ and $\{x_i, y'_i\}$ respectively.

In summary, for any $1 \leq i \leq \ell$, there are MISs which respectively intersect the set $\{x_i, x'_i, y_i, y'_i\}$ in pairs $\{x_i, y_i\}$, $\{x_i, y'_i\}$, $\{x'_i, y_i\}$, and $\{x'_i, y'_i\}$. Referring to our previous observation, this ensures us that all vertices in gadgets H_i are covered by MISs of G_+ . As a conclusion, G_+ is 1-extendable. \square

Observe that the assumptions concerning the MISs of G_+ are essential if we want pairs $\{x_i, y_i\}$, $\{x_i, y'_i\}$, $\{x'_i, y_i\}$, and $\{x'_i, y'_i\}$ of each gadget H_i to be covered by MISs. This property is not achieved by all 1-extendable graphs G : take for instance an embedding of some complete bipartite graph $K_{n,n}$ with $n \geq 3$, every MIS intersects each crossing on exactly two vertices.

4.2 Planar embedding

The GJS-gadget is a key tool in our proof that 1-EXTENDABILITY is NP-hard on planar graphs. We reduce from an NP-hard variant of 3SAT called PLANAR MONOTONE RECTILINEAR 3SAT, abbreviated PMR 3SAT. Given an input φ of PMR 3SAT, we design a graph G_φ such that φ is satisfiable iff G_φ is 1-extendable. Furthermore, G_φ is planar and its maximum degree is 3. We begin with the construction of G_φ step by step. Then, we show that the 1-extendability of G_φ depends on the satisfiability of the formula φ .

Starting point of the reduction. We reduce from PMR 3SAT, which is NP-hard de Berg and Khosravi (2010). In this variant of 3SAT, clauses and

variables can be represented in the plane in a certain way. The input is a set of variables $X = \{x_1, \dots, x_n\}$ and a CNF-SAT formula φ over X with exactly three variables per clause. The clauses C_1, \dots, C_m are *monotone*: they contain either three positive literals or three negative literals. Moreover, φ admits a *rectilinear* representation, that we now explain. Each variable is a point on the x-axis. The positive (resp. negative) clauses are represented by horizontal segments above (resp. below) the x-axis. When a variable x_i appears in a given clause, a vertical edge must connect the point x_i on the x-axis with the segment of this clause (at any point of the segment). Such a representation is rectilinear if no edge crosses a clause segment. Fig. 5 provides an example of a formula φ , with $m = 5$, which admits a rectilinear representation.

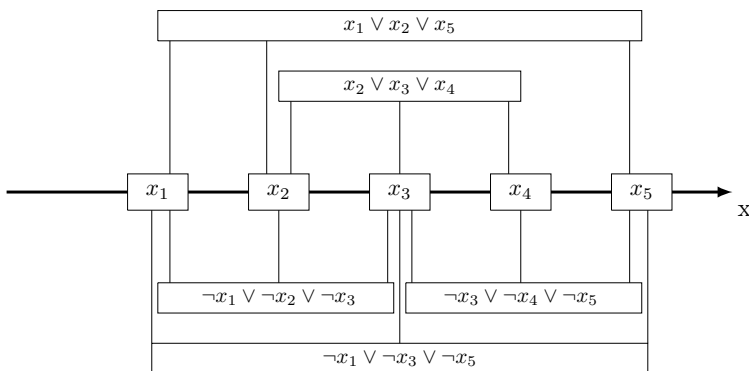

Fig. 5: A rectilinear representation of a PMR 3SAT instance C_1, \dots, C_5

Let φ be an input of PMR 3SAT provided with its rectilinear representation. The construction of G_φ depends on the rectilinear representation of φ . We proceed with two intermediate steps: first graph G''_φ , second graph G'_φ .

Construction of G''_φ . The first step is inspired from Mohar's reduction Mohar (2001) for MAXIMUM INDEPENDENT SET. We replace each variable x_i on the x-axis by a cycle. Let r be the number of appearances of x_i (as a literal x_i or $\neg x_i$) in the clauses C_1, \dots, C_m of φ . The point representing variable x_i becomes a cycle $x_i^1, \bar{x}_i^1, x_i^2, \bar{x}_i^2, \dots, x_i^r, \bar{x}_i^r$ of length $2r$, drawn as an axis-parallel rectangle (see Fig. 6a). We denote by c^* the total number of vertices in the variable cycles. Each clause $C_j = \ell_j^1 \vee \ell_j^2 \vee \ell_j^3$ is replaced by a triangle T_j of three vertices v_j^1, v_j^2, v_j^3 . The edges of these triangles are called *T-edges*. Each vertex of the clause is placed at the intersection between the clause segment and vertical edges of the rectilinear representation. In this way, vertices v_j^1, v_j^2 and v_j^3 are aligned horizontally and, w.l.o.g, we assume v_j^1 (resp. v_j^3) is the leftmost (resp. rightmost) vertex of T_j on the clause segment. Edges $v_j^1 v_j^2$ and $v_j^2 v_j^3$ are drawn as straight lines. The third one, $v_j^1 v_j^3$, can be represented as an almost flat curve, passing above (resp. below) vertex

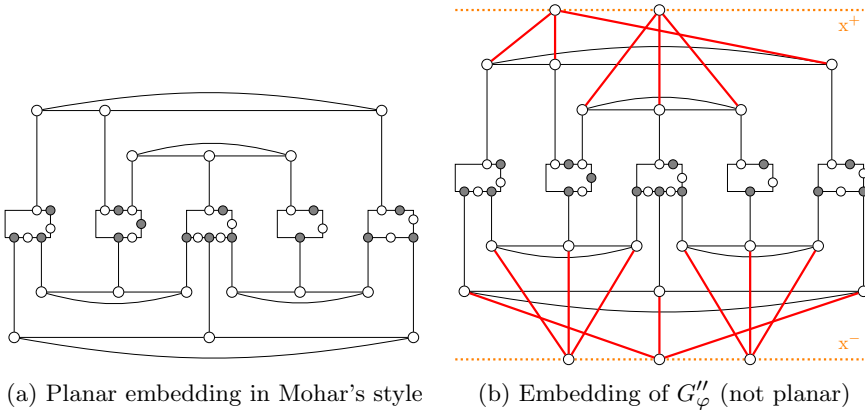

Fig. 6: Graph G''_φ with and without pendant vertices.

v_j^q for positive (resp. negative) clauses. If $\ell_j^q = x_i$ for some $1 \leq j \leq m$ and $q \in \{1, 2, 3\}$, then vertex v_j^q is connected to some cycle vertex \bar{x}_i^s of the top of the rectangle. Otherwise, if $\ell_j^q = \neg x_i$, then vertex v_j^q is connected to some cycle vertex x_i^s of the bottom of the rectangle. For now, the described embedding is planar. Fig. 6a shows the embedding of the instance of Fig. 5. Vertices \bar{x}_i^s are drawn in grey to distinguish them from vertices x_i^s (in white).

Less formally, each parity of a variable cycle represents a certain assignment of this variable. Picking up all x_i^1, x_i^2, \dots (resp. all $\bar{x}_i^1, \bar{x}_i^2, \dots$) into an independent set will correspond to assigning x_i to False (resp. True).

We add a “pendant” vertex π_j for any triangle T_j , $1 \leq j \leq m$, that is, π_j is adjacent to all vertices of T_j . The edges created by this operation, *i.e.* all $v_j^q \pi_j$, are called *pendant edges*. Consider the following embedding. We fix two horizontal axes x^+ and x^- : the first one above the x -axis and all segments of the positive clauses, the second one below the x -axis and all segments of the negative clauses. The pendants issued from the positive clauses are placed on the x^+ -axis such that every edge (v_j^2, π_j) is vertical. We represent edges (v_j^1, π_j) and (v_j^3, π_j) as straight lines (they cannot be vertical). We proceed similarly with pendants of the negative clauses on the x^- -axis. We denote by G''_φ the obtained graph. Its embedding is not planar. Fig. 6b shows graph G''_φ corresponding to the instance φ of Fig. 5. Pendant edges are drawn in red. We claim that each vertex of G''_φ belongs to an MIS. This might seem counter-intuitive, but the equivalence between the 1-extendability of the output instance and the satisfaction of φ will appear later (when we will eventually define G_φ).

Lemma 6 Graph G''_φ is 1-extendable.

Proof Sets $\{v_j^1, v_j^2, v_j^3, \pi_j\}$, for any $1 \leq j \leq m$, form an induced K_4 . Hence there is a clique cover made up of all clauses K_4 together with half of the edges of the variable cycles. Hence an MIS of G''_φ has size at most $m + c^*/2$. Here is an independent set of size $m + c^*/2$: pick up all pendant vertices π_j , $1 \leq j \leq m$, and, for each variable, an MIS of the corresponding variable cycle (each cycle, being of even length, has two MISs, we may take any of them). This shows not only that $\alpha(G''_\varphi) = m + c^*/2$ but also that all pendant and cycle vertices belong to some MIS. Finally, each triangle vertex v_j^q also belongs to an MIS: in the variable cycle adjacent to v_j^q , take the MIS not adjacent to v_j^q ; in the other variable cycles, take any MIS in it; finally, take the pendant vertices of the other clauses (*i.e.* π_h for $h \neq j$). \square

Construction of G'_φ . The second step consists in transforming G''_φ into some equivalent graph G'_φ which is planar and has maximum degree 3. Two types of crossings appear in the embedding of G''_φ . Each of them necessarily involve pendant edges.

- **Type A:** a pendant edge $v_j^q \pi_j$ crosses a T -edge $v_{j'}^{p'} v_{j'}^{q'}$ (we may have $j = j'$),
- **Type B:** a pendant edge $v_j^q \pi_j$ crosses another pendant edge $v_{j'}^{q'} \pi_{j'}$, $j \neq j'$.

We observe that for any of these types of crossings in the embedding of G''_φ , the assumptions of Proposition 4 are fulfilled.

Lemma 7 Let $\{uu', vv'\}$ be a crossing of the embedding of G''_φ . There exist two MISs $S_u, S_{u'}$ of G''_φ which intersect $\{u, u', v, v'\}$ respectively in $\{u\}$ and $\{u'\}$.

Proof We distinguish two cases, depending on the type of crossing.

Type A. Let $uu' = v_j^q \pi_j$ and $vv' = v_{j'}^{p'} v_{j'}^{q'}$. Let S_u be the MIS containing v_j^q with all pendant vertices π_h , $h \neq j$ of other clauses (and $c^*/2$ cycle vertices selected properly). Let $S_{u'}$ be the MIS containing all pendant vertices (plus $c^*/2$ cycle vertices).

Type B. Let $uu' = v_j^q \pi_j$ and $vv' = v_{j'}^{q'} \pi_{j'}$. We fix some $p' \in \{1, 2, 3\}$, $p' \neq q'$. Let S_u be the MIS we finally obtain by picking up v_j^q , $v_{j'}^{p'}$, and all pendant vertices π_h , $h \neq j, j'$. There is no assignment conflict between v_j^q and $v_{j'}^{p'}$ since only pendant edges involving literals of the same sign can cross each other with the monotone rectilinear representation. Similarly, let $S_{u'}$ be the MIS we obtain by taking $v_{j'}^{q'}$ and all pendant vertices π_h , $h \neq j'$, in particular $u' = \pi_j$. \square

As a consequence of Lemma 7 together with Proposition 4, one can replace each crossing of the embedding of G''_φ by a gadget H_{GJS} without altering its 1-extendability. The graph obtained is thus planar and has maximum degree 6 (which is the maximum degree of graph H_{GJS}). Then, we apply transformation (T_3) with $\Delta = 6$ to decrease its maximum degree. Finally, we obtain graph G'_φ , which is planar and has maximum degree 3.

Lemma 8 Graph G'_φ is 1-extendable.

Proof First, apply Lemma 7 together with Proposition 4, second Lemma 4. \square

According to Transformation (T_3) , each vertex u of G''_φ is transformed into an induced path P_u of length 11 in G'_φ . There is a natural correspondence between the MISs of G''_φ and those of G'_φ . Given an MIS S'' of G''_φ , one can produce an MIS S' of G'_φ such that the paths P_u with $|P_u \cap S'| = 6$ represent the vertices $u \in S''$. Conversely, let S' be some MIS of G' : picking up the vertices u such that $|P_u \cap S'| = 6$ produces an MIS of G''_φ . In the remainder of the section, when we say that a vertex $u \in G''_\varphi$ belongs to an MIS S' of G'_φ , we actually mean that $|P_u \cap S'| = 6$.

Construction of G_φ . We are now ready to describe the final graph G_φ which consists in a small extension of G'_φ . We add a cycle $z_1, \bar{z}_1, \dots, z_m, \bar{z}_m$ of size $2m$ to the graph G'_φ . Let $Z = \{z_1, z_2, \dots, z_m\}$ and $\bar{Z} = \{\bar{z}_1, \bar{z}_2, \dots, \bar{z}_m\}$. We connect z_j to π_j for every $1 \leq j \leq m$ - concretely, as π_j became an induced path via transformation (T_3) , we add an edge between z_j and a vertex of P_{π_j} . The graph obtained is G_φ and its size is polynomial in $|\varphi|$. The graph G_φ is planar: consider the embedding of G'_φ , draw the cycle $Z \cup \bar{Z}$ as a rectangle surrounding it and such that all edges $\pi_j z_j$ are vertical. Its maximum degree is 3. We are now ready to prove our result.

Theorem 5 1-EXTENDABILITY is NP-hard, even on planar graphs of maximum degree 3.

Proof We begin with the proof that $\alpha(G_\varphi) = \alpha(G'_\varphi) + m$. The value $\alpha(G'_\varphi) + m$ is clearly an upper bound of the size of independent sets in G_φ as they cannot contain $m + 1$ elements of $Z \cup \bar{Z}$. Moreover, the union of any MIS of G'_φ with \bar{Z} is an independent set of this size. As a consequence, for all $S \subseteq V(G_\varphi)$, S is an MIS of G_φ iff $S \cap V(G'_\varphi)$ is an MIS of G'_φ and $S \cap (Z \cup \bar{Z})$ is an MIS of $G[Z \cup \bar{Z}]$. As G'_φ is 1-extendable (Lemma 8), we know that all vertices of $V(G'_\varphi)$ belong to some MIS of G_φ . Moreover $G[Z \cup \bar{Z}]$ contains exactly two MIS: Z and \bar{Z} . As said previously, every vertex of \bar{Z} is contained in an MIS of G'_φ . Hence, G_φ is 1-extendable iff it admits an MIS containing Z .

Assume φ is satisfiable: there is an assignment A of variables which satisfies φ . We describe an MIS of G''_φ , which can easily be transformed into an MIS of G'_φ . If x_i 's assignment via A is **True**, we pick vertices $\bar{x}_i^1, \bar{x}_i^2, \dots$ of its variable cycle, otherwise we pick the other parity x_i^1, x_i^2, \dots . Therefore, if x_i 's assignment is **True**, we cannot pick any triangle vertex representing $\neg x_i$ as it is in conflict with one \bar{x}_i^q . This assignment A is such that at least one literal of each clause is assigned to **True**. So, for each clause C_j , we select arbitrary one of its literals ℓ_j^q which is positively assigned with A and pick the vertex v_j^q . The chosen vertices form an independent set S''_A of size $\alpha(G''_\varphi)$ in G''_φ . Observe that S''_A does not contain any pendant vertex. This set S''_A can be transformed into a corresponding MIS S'_A in G'_φ which contains 6 vertices per path

P_u if $u \in S''_A$. Thus, no pendant π_j belongs to S'_A . As the neighborhood of Z in G_φ is made up only of pendants π_j , $S'_A \cup Z$ is an MIS of G_φ and the graph is 1-extendable.

Suppose now that G_φ is 1-extendable. So there is an MIS $Z \cup S'$ of G_φ , with $S' \subseteq V(G'_\varphi)$. We know that, from S' , we can retrieve an MIS S'' of G''_φ which contains vertices u such that $|P_u \cap S'| = 6$. The set S'' cannot contain pendant vertices as they are all “adjacent” to Z in G_φ . We propose the following variable assignment A . Half of the vertices of the variable cycles must be in S'' , otherwise it would not be an MIS. Consequently, if x_i^1, x_i^2, \dots belong to S'' , we assign x_i to **False**, otherwise to **True**. Let us check that all clauses are satisfied. The set S'' contains exactly one vertex per triangle representing C_j . This vertex must be in accordance with the parity of the variable cycle which is in S'' : for example, if $\ell_j^q = \neg x_i$ and $v_j^q \in S''$, then we have $x_i^1, x_i^2, \dots \in S''$, otherwise S'' would not be independent. Hence, S'' cannot contain two vertices v_j^q and $v_{j'}^q$, such that $\ell_j^q = \neg \ell_{j'}^q$. In summary, assignment A satisfies φ . \square

As for MAXIMUM INDEPENDENT SET, the problem 1-EXTENDABILITY is NP-hard on subcubic planar graphs. If we put aside the degree criterion, one can see that this proof also works if we do not use transformation (T_3) . However, it stays relatively tricky, while the NP-hardness of MAXIMUM INDEPENDENT SET for planar graphs consists only in replacing each crossing of an arbitrary embedding of G by the GJS-gadget. Unfortunately, as mentioned in Section 4.1, such reduction does not work for 1-EXTENDABILITY. We wonder whether a new gadget, certainly not so much different from H_{GJS} , could be designed to make this reduction simpler.

4.3 Unit disk graphs

Unit disk graphs [Clark et al \(1990\)](#) stand as a natural model for wireless networks. Indeed, they are defined as the intersection graph of n equal-sized disks in the plane, which can represent Wi-Fi access points with the same radio range. There exists a way to represent subdivided planar graphs with degree at most 4 as unit disk graphs, based on a result from [Valiant \(1981\)](#).

Theorem 6 ([Valiant \(1981\)](#)) *A planar graph G with maximum degree 4 can be embedded in the plane inside a $O(|V(G)|)$ -sized area in such a way that any vertex is at integer coordinates and each edge is made up of vertical and horizontal line segments.*

Consider a subcubic planar graph G with such an embedding. We subdivide the edges of G such that (i) a vertex is placed at each turn of every edge (ii) each segment (between two turns) is subdivided at least once and (iii) the distance between two adjacent vertices is at most half of the length of the shortest segment. The graph obtained - say G^{UD} - is unit disk. Indeed, each vertex - admitting at most four neighbors, each of them placed either in the two horizontal or vertical directions - can be represented as a disk \mathcal{D} with center d such that:

- it intersects a disk \mathcal{D}_N (resp. $\mathcal{D}_S, \mathcal{D}_W, \mathcal{D}_E$) with center d_N (resp. d_S, d_W, d_E) where arc $\overrightarrow{dd_N}$ (resp. $\overrightarrow{dd_S}, \overrightarrow{dd_W}, \overrightarrow{dd_E}$) indicates the North direction (resp. South, West, East)
- disks $\mathcal{D}_N, \mathcal{D}_S, \mathcal{D}_W, \mathcal{D}_E$ do not intersect each other

In summary, given a subcubic planar graph G , one can produce in polynomial-time a unit disk graph G^{UD} thanks to transformation (T_2) . According to Lemma 3, G is 1-extendable iff G^{UD} is 1-extendable.

Theorem 7 1-EXTENDABILITY is NP-hard, even on unit disk graphs.

5 Parameterized algorithms

In this section we study a parameterized version of the 1-extendability problem:

PARAM-1-EXTENDABILITY

Parameter: k

Input: A graph G , an integer k

Question: Does every vertex of G belong to an independent set of size k ?

We first show that the problem remains $W[1]$ -hard by a reduction from MULTICOLORED INDEPENDENT SET. We then investigate the existence of polynomial kernels in restricted graph classes.

Theorem 8 PARAM-1-EXTENDABILITY is $W[1]$ -hard.

Proof We reduce from MULTICOLORED INDEPENDENT SET, where the input is a graph G whose vertex set is partitioned into k cliques C_1, \dots, C_k , and the goal is to find an independent set of size k . We add, for every $i \in [k]$, a pendant vertex π_i adjacent to all vertices of C_i . We also add a vertex ω adjacent to $\pi_i, i \in [k]$, and a vertex π_ω adjacent to ω only. Let G' be the obtained graph. We claim that every vertex of G' is contained in an independent set of size $k+1$ iff G contains an independent set of size k . If G contains an independent set S of size k , then:

- for every $i \in [k]$, every $x \in C_i$, then x together with $\{\pi_j : j \neq i\} \cup \{\pi_\omega\}$ is an independent set of size $k+1$
- S together with ω is an independent set of size $k+1$.
- the set $\{\pi_i : i \in [k]\} \cup \{\pi_\omega\}$ is an independent set of size $k+1$.

Conversely, assume ω is in an independent set of size $k+1$. Then, since the set of non-neighbors of ω is G itself, it implies that G must contain an independent set of size k , which concludes the proof. \square

By using Lemma 1, the problem is FPT in every hereditary graph class where MAXIMUM INDEPENDENT SET is FPT. Examples of such classes are planar graphs and triangle-free graphs (and more generally graphs excluding a clique of size r as an induced subgraph, for every fixed $r \geq 3$) where, in

addition, MAXIMUM INDEPENDENT SET admits a kernel of polynomial size. The reduction of Lemma 1, however, does not preserve polynomial kernels (although it naturally gives polynomial *Turing* kernels). Hence, it is natural to ask whether PARAM-1-EXTENDABILITY admits a polynomial kernel in these classes. We answer positively to this question.

We say that a hereditary graph class \mathcal{C} is MIS- (c, t) -friendly, for two non-zero constants c and t , if every graph of the class on n vertices contains an independent set of size at least $t \cdot n^c$, and such an independent set can be found in polynomial-time.

Theorem 9 *Let \mathcal{C} be an MIS- (c, t) -friendly class. PARAM-1-EXTENDABILITY on \mathcal{C} admits a kernel with $O(k^{\frac{1}{c} + \frac{1}{c^2}})$ vertices.*

Proof Let $G \in \mathcal{C}$, and $k \in \mathbb{N}$. Let \mathcal{A} be the algorithm which, for every graph of \mathcal{C} on n vertices, returns an independent set of size $t \cdot n^c$. We assume $|V(G)| \geq \left(\frac{k}{t}\right)^{\frac{1}{c}}$, since otherwise we are done. We invoke \mathcal{A} on G in order to get an independent set S_0 , which is thus of size at least k . We remove S_0 and repeat the process on the remaining vertices until \mathcal{A} outputs a small independent set. More precisely, let $R_1 = V(G) \setminus S_0$, and start with $i = 1$. We run \mathcal{A} on $G[R_i]$ which outputs an independent set S_i . If $|S_i| < k$, we stop the process, and otherwise we continue with $R_{i+1} = R_i \setminus S_i$, and increment i . Eventually, we end up with a partition of $V(G)$ into S_0, S_1, \dots, S_q and R_{q+1} (we might have $q = 0$). Every S_i is an independent set of size at least k in G . As $G[R_{q+1}] \in \mathcal{C}$, algorithm \mathcal{A} produces an independent set of size $t|R_{q+1}|^c < k$ on it, so $|R_{q+1}| < \left(\frac{k}{t}\right)^{\frac{1}{c}}$.

We now describe a reduction rule which consists of a marking procedure of some vertices of S_0 , and removing those which were not marked. We then show that if the reduction rule does not remove any vertex, then it means that the graph has the desired number of vertices.

Marking procedure. First, mark k vertices of S_0 chosen arbitrarily. For every $x \in R_{q+1}$, let s_x be the number of non-neighbors of x in S_0 . Second, for each $x \in R_{q+1}$, mark $\min\{k - 1, s_x\}$ vertices of S_0 chosen arbitrarily. As announced, we remove all vertices of S_0 which were not marked by the previous procedure.

Safeness. Let G' be the graph obtained after the reduction rule, and S'_0 the vertices of $V(G') \cap S_0$. Suppose every vertex of G' belongs to an independent set of size k . We only need to show that every removed vertex is in an independent set of size k in G . This is indeed the case, as we only removed vertices from S_0 and we kept at least k vertices from S_0 . Conversely, suppose that every vertex of G is in an independent set of size k . Then:

- since $|S'_0| \geq k$ (as we marked k vertices from S_0), every vertex of S'_0 belongs to an independent set of size k .
- For every $i \in [q]$, since each S_i is of size at least k , every vertex of each S_i is in an independent set of size at least k
- for every $x \in R_{q+1}$, let S be an independent set of size k in G containing x . Since $|S \cap S_0| \leq k - 1$, we necessarily marked at least $|S \cap S_0|$ non-neighbors

of x in S_0 , hence we can always replace the removed vertices of S by other vertices of S'_0 so that x belongs to an independent set of size k in G' .

Size of the reduced instance.

We apply the reduction rule as long as we can. Since we remove at least one vertex if the reduction rule applies, the algorithm must end after $O(|V(G)|)$ applications of the rule. Then, if the reduction rule cannot apply, it means we mark all vertices of S_0 . But since we mark at most $k + (k - 1) \cdot \left(\frac{k}{t}\right)^{\frac{1}{c}}$ vertices of S_0 , and S_0 is of size at least $t \cdot |V(G)|^c$, it means that G has $O(k^{\frac{1}{c^2} + \frac{1}{c}})$ vertices. This concludes the proof of the theorem. \square

We now apply the previous theorem to planar graphs and K_r -free graphs. By the Four Color Theorem, every planar graph on n vertices contains an independent set of size $n/4$ which can be found in polynomial-time. Hence, planar graphs is an MIS- $(1, 1/4)$ -friendly class. More generally, d -degenerate graphs are MIS- $(1, \frac{1}{d+1})$ -friendly. By Ramsey's theorem, for every $r \geq 3$, every K_r -free graphs on n vertices contains an independent set of size $n^{\frac{1}{r-1}}$ which can be found in polynomial-time. Hence, K_r -free graphs is an MIS- $(\frac{1}{r-1}, 1)$ -friendly class.

Corollary 2 PARAM-1-EXTENDABILITY admits a kernel with $O(k^2)$ vertices on planar graphs and d -degenerate graphs for bounded d , and a kernel with $O(k^{r^2})$ vertices on K_r -free graphs for every fixed $r \geq 3$.

6 Conclusion and further research

We investigated the computational complexity of 1-EXTENDABILITY. We showed that it cannot be solved in subexponential-time in general graphs unless the ETH fails, and that it remains NP-hard in subcubic planar graphs and in unit disk graphs. Although this behavior seems to be the same as MAXIMUM INDEPENDENT SET, we proved that MAXIMUM INDEPENDENT SET remains NP-hard (and even W[1]-hard) in 1-extendable graphs. It seems challenging to find a larger class of graphs where 1-EXTENDABILITY is polynomial-time solvable (but not trivial) while MAXIMUM INDEPENDENT SET remains NP-hard.

Another interesting subject would be to characterize 1-extendable graphs of graph classes where MAXIMUM INDEPENDENT SET is polynomial-time solvable: *e.g.* chordal graphs, cographs, claw-free graphs. Such outcomes would extend the result of [Dean and Zito \(1994\)](#) which state that bipartite graphs are 1-extendable iff they admit a perfect matching.

We also studied PARAM-1-EXTENDABILITY, a parameterized version of 1-EXTENDABILITY and showed that some results for MAXIMUM INDEPENDENT SET could also be obtained for PARAM-1-EXTENDABILITY (although not being as direct). It would be interesting to determine whether this is also the case for

other results about MAXIMUM INDEPENDENT SET [Bonnet et al \(2020, 2019\)](#); [Dabrowski et al \(2012\)](#), for instance: is PARAM-1-EXTENDABILITY W[1]-hard in C_4 -free graphs and in $K_{1,4}$ -free graphs? Does it admit a polynomial kernel in diamond-free graphs?

Finally, because of its applications in network design, finding an efficient algorithm which works well in practice is of high importance. Toward this, a first step would be to determine in which cases a vertex addition (or deletion) preserves the property of being 1-extendable. We note that such results have already been obtained for the related property of being well-covered [Finbow and Whitehead \(2018\)](#).

Declarations

Funding

Partially supported by the LABEX MILYON (ANR-10-LABX-0070) of Université de Lyon, within the program “Investissements d’Avenir” (ANR-11-IDEX-0007), and the research grant ANR DIGRAPHS ANR-19-CE48-0013-01, operated by the French National Research Agency (ANR).

References

- Alekseev V (1982) The effect of local constraints on the complexity of determination of the graph independence number. *Combinatorial-Algebraic Methods in Applied Mathematics* pp 3–13
- Angaleeswari K, Sumathi P, Swaminathan V (2015) k -extendability in graphs. *International Journal of Pure and Applied Math* 101(5):801–809
- Angaleeswari K, Sumathi P, Swaminathan V (2016) Weakly k -extendable graphs. *International Journal of Pure and Applied Math* 109(6):35–40
- de Berg M, Khosravi A (2010) Optimal binary space partitions in the plane. In: *Proc. of COCOON*, pp 216–225
- Berge C (1981) Some common properties for regularizable graphs, edge-critical graphs and B-graphs. *Graph Theory and Algorithms, Lecture Notes in Computer Science* 108:108–123
- Bonnet É, Bousquet N, Thomassé S, et al (2019) When maximum stable set can be solved in FPT time. In: *Proc. of ISAAC*, pp 49:1–49:22
- Bonnet É, Bousquet N, Charbit P, et al (2020) Parameterized complexity of independent set in H -free graphs. *Algorithmica* 82(8):2360–2394
- Chvátal V, Slater PJ (1993) A note on well-covered graphs. In: *Quo Vadis, Graph Theory?*, *Annals of Discrete Mathematics*, vol 55. Elsevier, p 179–181

- Clark BN, Colbourn CJ, Johnson DS (1990) Unit disk graphs. *Discret Math* 86(1-3):165–177
- Cygan M, Fomin FV, Kowalik L, et al (2015) *Parameterized Algorithms*. Springer
- Dabrowski KK, Lozin VV, Müller H, et al (2012) Parameterized complexity of the weighted independent set problem beyond graphs of bounded clique number. *J Discrete Algorithms* 14:207–213
- Dean N, Zito JS (1994) Well-covered graphs and extendability. *Discret Math* 126(1-3):67–80
- Finbow AS, Whitehead CA (2018) Constructions for well-covered graphs. *Australasian Journal of Combinatorics* 72(2):273–289
- Garey MR, Johnson DS, Stockmeyer LJ (1976) Some simplified NP-complete graph problems. *Theor Comput Sci* 1(3):237–267
- Grzesik A, Klimosová T, Pilipczuk M, et al (2019) Polynomial-time algorithm for maximum weight independent set on P_6 -free graphs. In: *Proc. of SODA*. SIAM, pp 1257–1271
- Hackfeld J, Koster A (2018) The matching extension problem in general graphs is co-NP-complete. *J Comb Optim* 35(3):853–859
- Impagliazzo R, Paturi R (2001) On the complexity of k -SAT. *J Comput Syst Sci* 62(2):367–375
- Liew SC, Kai CH, Leung HC, et al (2010) Back-of-the-envelope computation of throughput distributions in CSMA wireless networks. *IEEE Transactions on Mobile Computing* 9(9):1319–1331
- Mohar B (2001) Face covers and the genus problem for apex graphs. *J Comb Theory, Ser B* 82(1):102–117
- ns3 (2022) The Network Simulator ns-3. <https://www.nsnam.org/>, accessed: 2021-09-30
- Plummer MD (1970) Some covering concepts in graphs. *Journal of Combinatorial Theory* 8(1):91–98
- Plummer MD (1980) On n -extendable graphs. *Discrete Math* 31:201–210
- Plummer MD (1994) Extending matchings in graphs: A survey. *Discret Math* 127(1-3):277–292

- Poljak S (1974) A note on stable sets and colorings in graphs. *Commentationes Mathematicae Universitatis Carolinae* pp 307–309
- Ravindra G (1976) B-graphs. In: *Proc. Symp. Graph Theory, ISI Lecture Notes Calcutta*, pp 268–280
- Ravindra G (1977) Well covered graphs. *J Combin Inform System Sci* 2:20–21
- Sankaranarayana RS, Stewart LK (1992) Complexity results for well-covered graphs. *Networks* 22(3):247–262
- Tankus D, Tarsi M (1996) Well-covered claw-free graphs. *Journal of Combinatorial Theory, Series B* 66(2):293–302
- Valiant LG (1981) Universality considerations in VLSI circuits. *IEEE Trans Computers* 30(2):135–140