



**HAL**  
open science

# **DART-Lux: an unbiased and rapid Monte Carlo radiative transfer method for simulating remote sensing images**

Yingjie Wang, Abdelaziz Kallel, Xuebo Yang, Omar Regaieg, Nicolas Lauret, Jordan Guilleux, Eric Chavanon, Jean-Philippe Gastellu-Etchegorry

► **To cite this version:**

Yingjie Wang, Abdelaziz Kallel, Xuebo Yang, Omar Regaieg, Nicolas Lauret, et al.. DART-Lux: an unbiased and rapid Monte Carlo radiative transfer method for simulating remote sensing images. Remote Sensing of Environment, 2022, 274, pp.112973. 10.1016/j.rse.2022.112973 . hal-04643523

**HAL Id: hal-04643523**

**<https://hal.science/hal-04643523>**

Submitted on 10 Jul 2024

**HAL** is a multi-disciplinary open access archive for the deposit and dissemination of scientific research documents, whether they are published or not. The documents may come from teaching and research institutions in France or abroad, or from public or private research centers.

L'archive ouverte pluridisciplinaire **HAL**, est destinée au dépôt et à la diffusion de documents scientifiques de niveau recherche, publiés ou non, émanant des établissements d'enseignement et de recherche français ou étrangers, des laboratoires publics ou privés.

# 1 DART-Lux: an unbiased and rapid Monte Carlo radiative 2 transfer method for simulating remote sensing images

3

4 Yingjie Wang<sup>1</sup>, Abdelaziz Kallel<sup>3</sup>, Xuebo Yang<sup>2</sup>, Omar Regaieg<sup>1</sup>, Nicolas Lauret<sup>1</sup>, Jordan  
5 Guilleux<sup>1</sup>, Eric Chavanon<sup>1</sup>, Jean-Philippe Gastellu-Etchegorry<sup>1</sup>

6

7 <sup>1</sup> CESBIO, CNES-CNRS-IRD-UT3, University of Toulouse, 31401 Toulouse CEDEX 09,  
8 France

9 <sup>2</sup> Aerospace Information Research Institute, Chinese Academy of Sciences, Beijing 100094,  
10 China

11 <sup>3</sup> CRNS, ATMS, Sfax, Tunisia

12

13 Correspondence to: Yingjie WANG ([yingjiawang1102@gmail.com](mailto:yingjiawang1102@gmail.com)), Jean-Philippe Gastellu-  
14 Etchegorry ([jean-philippe.gastellu@iut-tlse3.fr](mailto:jean-philippe.gastellu@iut-tlse3.fr))

15

## 16 **Abstract**

17 Accurate and efficient simulation of remote sensing images is increasingly needed in order to  
18 better exploit remote sensing observations and to better design remote sensing missions. DART  
19 (Discrete Anisotropic Radiative Transfer), developed since 1992 based on the discrete ordinates  
20 method (*i.e.*, standard mode DART-FT), is one of the most accurate and comprehensive 3D  
21 radiative transfer models to simulate the radiative budget and remote sensing observations of  
22 urban and natural landscapes. Recently, a new method, called DART-Lux, was integrated into  
23 DART model to address the requirements of massive remote sensing data simulation for large-  
24 scale and complex landscapes. It is developed based on efficient Monte Carlo light transport

25 algorithms (*i.e.*, bidirectional path tracing) and on DART model framework. DART-Lux can  
26 accurately and rapidly simulate the bidirectional reflectance factor (BRF) and spectral images  
27 of arbitrary landscapes. This paper presents its theory, implementation, and evaluation. Its  
28 accuracy, efficiency and advantages are also discussed. The comparison with standard DART-  
29 FT in a variety of scenarios shows that DART-Lux is consistent with DART-FT (relative  
30 differences  $< 1\%$ ) with simulation time and memory reduced by a hundredfold. DART-Lux is  
31 already part of the DART version freely available for scientists (<https://dart.omp.eu>).

32

### 33 **Key words**

34 DART, Radiative transfer, Monte Carlo, Bidirectional path tracing, Remote sensing image

35

## 36 **1 Introduction**

37 Physically based three-dimensional (3D) models that simulate the interactions between  
38 electromagnetic radiation and the realistic terrestrial surfaces and that simulate the remotely  
39 sensed multi- and hyper-spectral images of these surfaces provide essential solutions for  
40 quantitative interpretation of remote sensing data and for the design of remote sensing missions.  
41 It explains that in the last four decades, a number of 3D radiative transfer (RT) models that can  
42 simulate the radiative and biophysical processes in 3D natural and/or urban landscape have  
43 been developed (Widlowski et al., 2015, 2013, 2007). These models can be divided into three  
44 categories according to their mathematical solution of RT equation: (i) radiosity methods, (ii)  
45 Monte Carlo methods and (iii) discrete ordinates methods.

46

47 Radiosity methods, such as DIANA (Goel et al., 1991) and RGM (Qin and Gerstl, 2000), solve  
48 the RT equation through the inversion of a square matrix that includes the geometric view  
49 factors of each surface relative to all other surfaces in the simulated scene. The advantage of

50 the radiosity method is that once the inverse square matrix is computed, the bidirectional  
51 reflectance factor (BRF), directional brightness temperature (DBT) and radiative budget of the  
52 scene can be easily derived. However, the major limitation is that its computation time and  
53 computer memory dramatically increase for complex scenes made of millions of facets. Also,  
54 it is less flexible to simulate other remote sensing signals such as LiDAR and polarization.  
55 Monte Carlo methods, such as FLIGHT (North, 1996), Raytran (Govaerts, 1996) and librat  
56 (Lewis, 1999), estimate the solution of RT equation by repeatedly sampling the ray paths in the  
57 scene. This stochastic process converges to the exact solution after sufficient trials and  
58 repetitions. The Monte Carlo method is usually considered as the most accurate, flexible, but  
59 also the most computer expensive solution of radiative transfer (Goel, 1988; Myneni et al.,  
60 1989). Discrete ordinates methods, such as the models of (Kimes and Kirchner, 1982; Myneni  
61 et al., 1990), DART (Gastellu-Etchegorry et al., 1996) and DIRSIG (Kraska, 1996), solve the  
62 RT equation along a finite number of discrete directions. Similar to Monte Carlo method, the  
63 discrete ordinates method is flexible to simulate the remote sensing signals and radiative budget  
64 of complex landscapes. It is known as a good compromise between accuracy and computation  
65 time.

66

67 The initial implementations of the 3D RT models in the 1980s and 1990s were usually adapted  
68 to small scale, schematic scenes, and provided limited remote sensing products (*e.g.*, BRF or  
69 image). The evolution of the remote sensing science, the ray-tracing algorithms, computer  
70 hardware and 3D representations of Earth surface elements explains the constant improvement  
71 of 3D RT models. For example, RAPID, developed on the basis of RGM, simplifies the  
72 representation of canopy by porous objects, which allows one to simulate complex vegetated  
73 scenes since only view factors between porous objects are computed and stored (Huang et al.,  
74 2013). Rayspread, a speeded up successor of Raytran, implements the variance reduction

75 technique called photon spreading that sends a group of virtual photons to all possible sensors  
76 after each interaction (Widlowski et al., 2006). It also provides absorption, transmission, and  
77 albedo products for studying photosynthesis and other physiological processes. The flexibility  
78 of discrete ordinates method and the increasing requirements of 3D RT modelling explain that  
79 DART and DIRSIG continuously extend their functionality for general-purpose remote sensing  
80 applications. The initial DART only simulated the BRF and images of turbid canopies in the  
81 short waves (Gastellu-Etchegorry et al., 1996). Later, it integrated a specifically designed  
82 atmospheric RT modelling module (Gascon et al., 2001) and was extended to the thermal  
83 infrared domain with the provision of 3D radiative budget of canopies (Guillevic et al., 2003).  
84 Afterwards, it integrated an additional representation of vegetation and urban elements by  
85 polygons with various surface optical properties (*e.g.*, Lambertian with specular, Hapke and  
86 RPV models) (Gastellu-Etchegorry, 2008), LiDAR and passive sensors (*e.g.*, pushbroom,  
87 airborne and in-situ camera) (Gastellu-Etchegorry et al., 2015; Yin et al., 2016), and sun  
88 induced fluorescence (SIF) (Gastellu-Etchegorry et al., 2017). Subsequently, it integrated a  
89 powerful ray-object intersection kernel Embree (Wald et al., 2014) that considerably  
90 accelerated it up to factors of  $\sim 300$  (Qi et al., 2019b), depending on the simulated landscapes.

91

92 Despite the continuous improvements of the functionality, accuracy and efficiency of the 3D  
93 RT models, it is still challenging to simulate realistic complex canopy scenes. For example,  
94 reference models in RAMI3 (RAdiative transfer Model Intercomparison) including DART had  
95 good  $\sim 1\%$  agreement for schematic canopies (Widlowski et al., 2007) but were less consistent  
96 for the RAMI4 realistic canopies (Widlowski et al., 2015). Indeed, simplifications of RT  
97 modelling and canopy mock-ups were likely applied by many 3D RT models to simulate the  
98 huge volumes of measurements of realistic canopies in a reasonable computer time. Taking  
99 DART as an example, the number of discrete directions was largely reduced, and the shoots of

100 pine trees were represented by voxels filled with turbid medium. It stresses the need to improve  
101 3D RT models and the management of mock-ups in order to handle large-scale and complex  
102 landscapes. The advancement of physically-based Monte Carlo light transport algorithms in  
103 computer graphics aimed at rapid rendering of colour images provides solutions (Kajiya, 1986;  
104 Pharr et al., 2016; Veach, 1997). Some of them are already integrated by recent 3D RT models.  
105 For example, DIRSIG was redesigned with the path tracing approach (Goodenough and Brown,  
106 2017; Kajiya, 1986), where a backward ray from the sensor is used to construct a stochastic  
107 path that either connects a light source or terminates on an absorbing surface. LESS uses the  
108 ray-tracer Mitsuba (Jakob, 2010; Nimier-David et al., 2019; Qi et al., 2019a), where a stochastic  
109 path is constructed either forward to simulate the BRF or backward to simulate images.

110

111 Standard DART modelling (*i.e.*, discrete ordinates method) is much less efficient than recent  
112 Monte Carlo-based models such as LESS in simulating precise images of large-scale and  
113 complex landscapes. For example, it takes more than 45 times memory and more than 20 times  
114 computation time than LESS to simulate the nadir image of the Järvselja Birch stand in RAMI4  
115 experiment (Qi et al., 2019a). Therefore, with the goal of fast, robust and accurate RT  
116 simulations for large-scale and complex landscapes, since 2018, we have been designing a new  
117 Monte Carlo method called “DART-Lux” in DART model. It is based on the standard DART  
118 framework and the Monte Carlo algorithm (*i.e.*, bidirectional path tracing) of the open-source  
119 renderer LuxCoreRender (<https://luxcorerender.org>). DART-Lux efficiently combines forward  
120 and backward light transport to robustly simulate any sensor-source configuration and surface  
121 scattering function, as detailed in section 3.

122

123 Usually, light transport algorithms in computer graphics aim at producing very fast and visually  
124 pleasing colour images or videos. They work with only three bands and with low radiometric

125 accuracy, which is not suitable for remote sensing applications. For example, sun and  
126 atmosphere illumination in outdoor scenarios is simulated using parameterized models (Hosek  
127 and Wilkie, 2012; Preetham et al., 1999), which is very approximative compared to the  
128 atmospheric RT modelling in MODTRAN and DART (Berk et al., 1987; Grau and Gastellu-  
129 Etchegorry, 2013; Wang and Gastellu-Etchegorry, 2020). Similarly, important physical and  
130 biophysical processes, such as polarization and SIF emission, are not considered. In contrast,  
131 3D RT models must accurately model all major radiation interactions in the atmosphere and  
132 landscapes for remote sensing applications. Therefore, three main types of development have  
133 been carried out in DART-Lux, some of them are still in progress: (1) RT modelling: SIF and  
134 thermal emission, realistic atmosphere and 3D clouds, any surface / volume scattering functions,  
135 polarization, *etc.* (2) Products: pushbroom and camera hyperspectral radiance / reflectance /  
136 brightness temperature / SIF images, 3D radiative budget, images per type of land cover (*e.g.*,  
137 tree, ground), LiDAR waveform, point cloud and photon counting, polarization components,  
138 look-up-tables for inversion and sensitivity work, *etc.* (3) Computer science: accurate ray-object  
139 intersection to avoid self-intersection and watertight intersection issues (Woo et al., 1996;  
140 Woop et al., 2013)), high radiometric accuracy, GPU acceleration, distributed computing, *etc.*

141

142 This paper presents the theoretical basis, framework architecture and evaluation of DART-Lux.  
143 Section 2 summarizes the mathematical formulation of image modelling and DART framework.  
144 Section 3 details DART-Lux theoretical basis and implementation. Section 4 compares the new  
145 DART-Lux and the standard DART with schematic and realistic urban and forest landscapes.  
146 Finally, section 5 discusses results and section 6 concludes the work and highlights perspectives.

147

## 148 2 Background and method

### 149 2.1 Mathematical formulation of remote sensing image modelling

150 A major objective of 3D RT modelling is to simulate remote sensing image (Gastellu-  
151 Etchegorry et al., 1996; Kraska, 1996; Lewis, 1999; Qi et al., 2019a; Richtsmeier et al., 2001).  
152 It is a two-dimensional map of the radiation that the Earth surfaces and the atmosphere emit  
153 and scatter to remote sensing sensor. This modelling can be explicitly formulated by a Lebesgue  
154 integration (Eq. (8)) as detailed below.

155

#### 156 2.1.1 Light transport equation

157 Radiation leaving a surface  $\Sigma$  is the sum of scattered and emitted radiation. Therefore, the exit  
158 radiance  $L(r, \Omega_o)$  along direction  $\Omega_o$  is the sum of emitted radiance  $L_e(r, \Omega_o)$  along direction  
159  $\Omega_o$  and scattered radiance to direction  $\Omega_o$  due to all incident radiance  $L(r, -\Omega_i)$  from the  $4\pi$   
160 space. It leads to the light transport equation, also called rendering equation (Kajiya, 1986):

$$L(r, \Omega_o) = L_e(r, \Omega_o) + \int_{4\pi} L(r, -\Omega_i) \cdot f(r, -\Omega_i, \Omega_o) \cdot \cos \theta_i d\Omega_i \quad (1)$$

161 with  $\theta_i$  the incident angle (Figure 1.a) and  $f(r, -\Omega_i, \Omega_o)$  the bidirectional scattering  
162 distribution function (BSDF) of surface  $\Sigma$  that is the bidirectional reflectance distribution  
163 function (BRDF)  $\frac{\rho(r, -\Omega_i, \Omega_o)}{\pi}$  or the bidirectional transmittance distribution function (BTDF)  
164  $\frac{\tau(r, -\Omega_i, \Omega_o)}{\pi}$ , depending on the relative configuration of the incident and exit directions (Eq. (2)).

$$f(r, -\Omega_i, \Omega_o) = \begin{cases} \frac{\rho(r, -\Omega_i, \Omega_o)}{\pi}, & \text{if } \langle \mathbf{n} \cdot \Omega_o \rangle \cdot \langle \mathbf{n} \cdot \Omega_i \rangle \geq 0 \\ \frac{\tau(r, -\Omega_i, \Omega_o)}{\pi}, & \text{otherwise} \end{cases} \quad (2)$$

165 Because solid angles depend on surface area, Eq. (1) is expressed in an area form (Eq. (3))  
166 where an integral over all scene surfaces  $A$  replaces the integral over angular space (Figure 1.b)



$$L(r' \rightarrow r) = L_e(r' \rightarrow r) + \int_A L(r'' \rightarrow r') \cdot f(r'' \rightarrow r' \rightarrow r) \cdot G(r' \leftrightarrow r'') dA(r'') \quad (3)$$

167 with  $r \in A(r) \subseteq A$  a point on a surface whose BSDF is  $f(r'' \rightarrow r' \rightarrow r)$ .  $G(r' \leftrightarrow r'') =$   
 168  $V(r' \leftrightarrow r'') \cdot \frac{\cos \theta_i^{r'} \cdot \cos \theta_o^{r''}}{\|r'' - r'\|^2}$  is a geometric term, with  $V(r' \leftrightarrow r'')$  the visibility function between  
 169  $r'$  and  $r''$ ,  $\theta_i^{r'}$  is the incident angle at  $r'$  and  $\theta_o^{r''}$  is the exit angle at  $r''$ .  $V(r' \leftrightarrow r'') = 1$  if  
 170 there is nothing between  $r'$  and  $r''$ , and 0 otherwise.

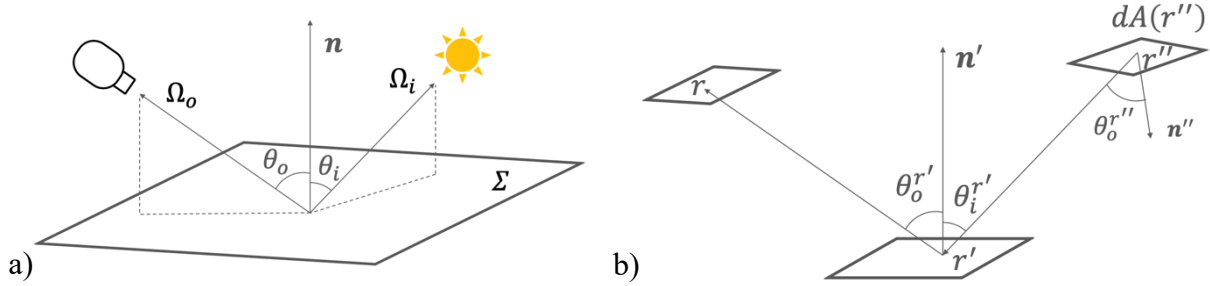

171  
 172 Figure 1. a) BSDF  $f(r, -\Omega_i, \Omega_o)$  of a surface  $\Sigma$  of normal  $\mathbf{n}$ : exit radiance along direction  $\Omega_o$  due to  
 173 the scattering of incident irradiance along direction  $-\Omega_i$ . Incident angle  $\theta_i$  is the angle  
 174 between  $\Omega_i$  and  $\mathbf{n}$ , exit angle  $\theta_o$  is the angle between  $\Omega_o$  and  $\mathbf{n}$ . (b) Three-point method: a ray  
 175 starts from  $r''$  on  $dA(r'')$  is intercepted at  $r'$ , then is scattered to  $r$ .

176

### 177 2.1.2 Path integral of light transport equation

178 In a scene with no media between surfaces, the incident radiance on a surface is the exit radiance  
 179 from previous surface. Therefore, Eq. (3) can be incrementally expanded to an infinite sum of  
 180 multiple-dimensional integration (Eq. (4)) with  $r_0$  a vertex on the sensor lens,  $r_1$  a previous  
 181 vertex, and so on. Each term is the result of emitted radiance  $L_e(r_n \rightarrow r_{n-1})$  after  $(n - 1)$   
 182 scattering events:

$$\begin{aligned}
L(r_1 \rightarrow r_0) &= L_e(r_1 \rightarrow r_0) + \int_A L_e(r_2 \rightarrow r_1) \cdot f(r_2 \rightarrow r_1 \rightarrow r_0) \cdot G(r_1 \leftrightarrow r_2) dA(r_2) \\
&+ \int_A \int_A L_e(r_3 \rightarrow r_2) \cdot f(r_3 \rightarrow r_2 \rightarrow r_1) \cdot G(r_2 \leftrightarrow r_3) \cdot f(r_2 \rightarrow r_1 \rightarrow r_0) \\
&\cdot G(r_1 \leftrightarrow r_2) dA(r_3) dA(r_2) \\
&+ \int_A \int_A \int_A L_e(r_4 \rightarrow r_3) \cdot f(r_4 \rightarrow r_3 \rightarrow r_2) \cdot G(r_3 \leftrightarrow r_4) \\
&\cdot f(r_3 \rightarrow r_2 \rightarrow r_1) \cdot G(r_2 \leftrightarrow r_3) \cdot f(r_2 \rightarrow r_1 \rightarrow r_0) \\
&\cdot G(r_1 \leftrightarrow r_2) dA(r_4) dA(r_3) dA(r_2) + \dots
\end{aligned} \tag{4}$$

183 Eq. (4) can be rewritten as:

$$L(r_1 \rightarrow r_0) = \sum_{n=1}^{\infty} L(\bar{r}_n) \tag{5}$$

184 with  $L(\bar{r}_n)$  the radiance from  $r_1$  to  $r_0$  integrated over all paths of length  $n$ , *i.e.*, path with  $n$  edges

185 and  $n + 1$  vertices, vertex  $r_n$  on the light source and vertex  $r_0$  on the sensor lens.  $\bar{r}_n = r_0 r_1 \dots r_n$

186 with  $r_{k=0,1,\dots,n} \in A$ , and  $\bar{r}_n \in$  path space  $\mathcal{D}_n$  ( $n \in \mathbb{N}^*$ ) with  $\mathcal{D}_n$  the set of paths of length  $n$ .

187 Figure 2 shows a path of length 4. If  $n = 1$ , we have  $L(\bar{r}_1) = L_e(r_1 \rightarrow r_0)$ . If  $n > 1$ , we have

$$\begin{aligned}
L(\bar{r}_n) &= \int_A f(r_2 \rightarrow r_1 \rightarrow r_0) \cdot G(r_1 \leftrightarrow r_2) \int_A \dots \int_A f(r_{n-1} \rightarrow r_{n-2} \rightarrow r_{n-3}) \\
&\cdot G(r_{n-2} \leftrightarrow r_{n-1}) \cdot \int_A L_e(r_n \rightarrow r_{n-1}) \cdot f(r_n \rightarrow r_{n-1} \rightarrow r_{n-2}) \\
&\cdot G(r_{n-1} \leftrightarrow r_n) dA(r_n) dA(r_{n-1}) \dots dA(r_2)
\end{aligned} \tag{6}$$

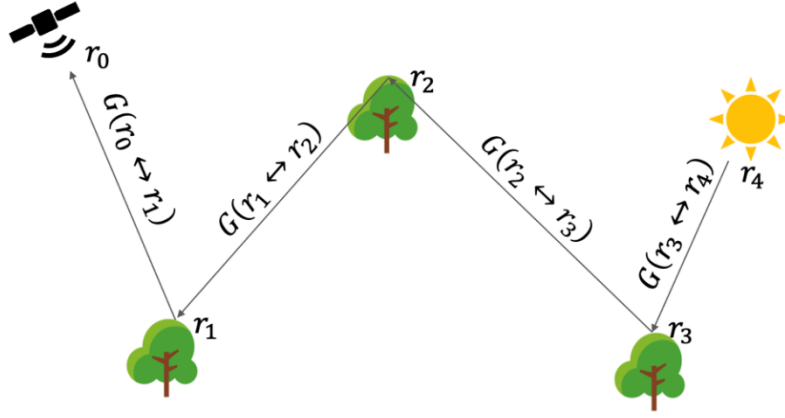

188

189 Figure 2. Path of length 4. It starts from light source at  $r_4$ , is successively scattered at  $r_3$ ,  $r_2$ ,  $r_1$ , and  
 190 finally reaches the sensor at  $r_0$ .

191

### 192 2.1.3 Instrumental characteristics

193 Figure 3 illustrates an example of pinhole camera. Radiation incident on pixel  $j$  is transferred  
 194 to radiance measurement  $L^{(j)}$  (Eq. (7)) using an importance function  $W_e(r_0, \Omega_0)$  (Nicodemus,  
 195 1978) whose expression depends on the instrumental characteristics (*cf.* appendix A).

$$L^{(j)} = \int_{A_0} \int_{\Delta\Omega_0} W_e^{(j)}(r_0, \omega_0) \cdot L(r_1 \rightarrow r_0) \cdot \cos \theta_i^{r_0} d\Omega_0 dA(r_0) \quad (7)$$

196 with  $W_e^{(j)}(r_0, \Omega_0) = 0$  if the incident ray is outside pixel  $j$ .  $\theta_i^{r_0}$  is the angle between the  
 197 incident direction and the principal optical axis.  $\Delta\Omega_0$  is the solid angle that encloses all  
 198 directions of the measured incident rays.  $A_0 \equiv A(r_0)$  is the lens area.

199

200 In Eq. (7) expanded with the expression of  $L(r_1 \rightarrow r_0)$  in Eq. (4),  $W_e$  and  $L_e$  are interchangeable  
 201 which means that  $W_e$  can be treated as an exit term in the same way as  $L_e$  (Christensen et al.,  
 202 1993). It gives the theoretical basis to backward light transport that is symmetric to the forward  
 203 light transport. Appendix B gives a mathematical formulation of backward light transport.

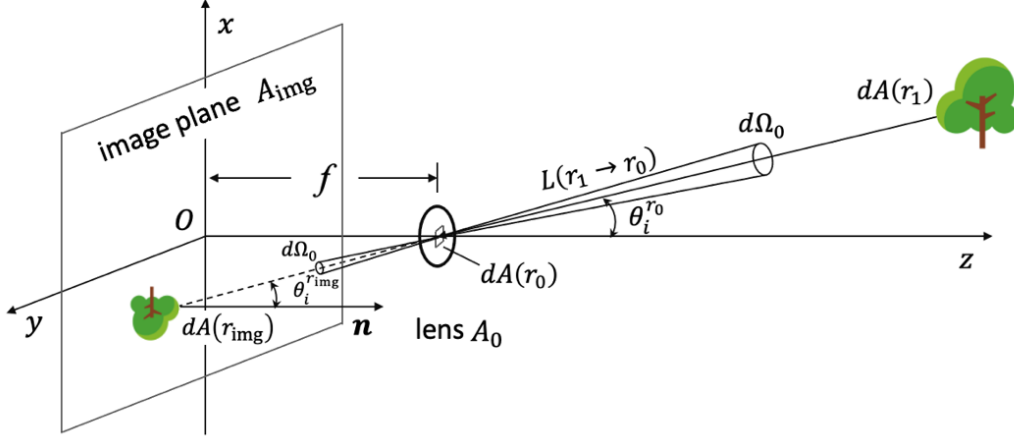

204

205 Figure 3. Pinhole camera. The lens with area  $A_0$  is at a distance  $f$  in front of the image plane of normal  
 206  $\mathbf{n}$ . Radiation from a differential surface  $dA(r_1)$  in the scene along direction  $r_1 \rightarrow r_0$  is focused  
 207 by the lens onto the differential surface  $dA(r_{\text{img}})$  in the image plane.

208

#### 209 2.1.4 Mathematical formulation of radiance measurement

210 The expanded form of Eq. (7) can be expressed in the more compact form:

$$L^{(j)} = \int_{\mathcal{D}} f^{(j)}(\bar{r}) d\mu(\bar{r}) \quad (8)$$

211 with  $f^{(j)}(\bar{r})$  the measurement contribution at pixel  $j$  and  $\mu$  the area-product measure,  $\mu(\mathcal{D}_n) =$

212  $\int_{\mathcal{D}_n} d\mu(\bar{r}_n) = \int_{\mathcal{D}_n} dA(r_n) \cdot dA(r_{n-1}) \dots dA(r_0)$ .  $\bar{r}$  is a path linking light source and sensor,  $\bar{r} \in \mathcal{D}$

213 path space and  $\mathcal{D} = \bigcup_{n=1}^{\infty} \mathcal{D}_n$ . For path  $\bar{r}_n$ ,  $f^{(j)}(\bar{r}_n)$  is defined as:

$$f^{(j)}(\bar{r}_n) = L_e(r_n \rightarrow r_{n-1}) \cdot G(r_0 \leftrightarrow r_1) \cdot W_e^{(j)}(r_0 \rightarrow r_1) \cdot \prod_{k=2}^n f(r_k \leftrightarrow r_{k-1} \leftrightarrow r_{k-2}) \cdot G(r_{k-1} \leftrightarrow r_k) \quad (9)$$

214 The notation  $f(r_k \leftrightarrow r_{k-1} \leftrightarrow r_{k-2})$  underlines the reciprocity of BSDF.

215

216 The contribution  $\int_{\mathcal{D}_n} f^{(j)}(\bar{r}_n) d\mu(\bar{r}_n)$  due to the  $(n-1)$ th scattering order is denoted as  $C_{\mathcal{D}_n}$ .  
 217 Then,  $C_{\mathcal{D}_1}$  represents the contribution of direct illumination,  $C_{\mathcal{D}_2}$  represents the contribution of  
 218 first order scattering, and so on. The radiance measurement is simply the sum of  $C_{\mathcal{D}_n}$  terms:

$$L^{(j)} = \int_{\mathcal{D}} f^{(j)}(\bar{r}) d\mu(\bar{r}) = \sum_{n=1}^{\infty} C_{\mathcal{D}_n} \quad (10)$$

219

## 220 2.2 DART model and its framework

221 DART (<https://dart.omp.eu>) is one of the most accurate and comprehensive 3D RT models in  
 222 the remote sensing community (Gastellu-Etchegorry et al., 2015, 1996). It simulates the  
 223 radiative budget, BRF, radiometric (*i.e.*, radiance, reflectance, brightness temperature) images  
 224 (Eq. (8)) of 3D natural and urban scenes from visible to thermal infrared domain. Its standard  
 225 iterative discrete ordinates method, called DART-FT, tracks radiation along  $N$  discrete  
 226 directions  $\{\Omega_n\}_{n=1,2,\dots,N}$ . Radiation intercepted in iteration  $k$  is scattered to  $N$  discrete directions  
 227 in iteration  $k+1$ . All radiation scattered in iteration  $k$  to a sensor contributes to  $C_{\mathcal{D}_{k+1}}$  (Eq. (10))  
 228 (Gastellu-Etchegorry et al., 1996). DART-FT had good agreement compared to the other five  
 229 benchmark models (*i.e.*, drat, FLIGHT, Rayspread, Raytran, SPRINT) in RAMI3 experiment  
 230 with 1% difference on average (Widlowski et al., 2007). It was also successfully evaluated with  
 231 the satellite, airborne and ground-based measurements which indicated a RMSE about 0.02 on  
 232 reflectance (Janoutová et al., 2019) and less than 2 K on brightness temperature (Guillevic et  
 233 al., 2003; Sobrino et al., 2011). DART also has a complete framework for 3D RT modelling  
 234 and for remote sensing and radiative budget applications (Gastellu-Etchegorry et al., 2015),  
 235 with specific input data, processing modules and output data (Figure 4).

236

237 **Input data.** Input data set up all the parameters to run a DART simulation. A graphical user  
238 interface (GUI) allows one to import / manage 3D objects and digital elevation models (DEM),  
239 define and assign optical and temperature properties, configure the atmosphere (geometry,  
240 vertical profile and optical properties of gas, aerosol and/or cloud), select the RT modelling  
241 method (*e.g.*, discrete ordinates, Monte Carlo) and the products. All input parameters are  
242 encoded in extensible markup language (XML) to ease data access.

243

244 **Processing modules.** Four major modules process input data to simulate products. (1) Direction:  
245 it subdivides the  $4\pi$  space into  $N$  user-defined discrete directions for ray tracking. (2) Phase: it  
246 computes band optical properties, temperature properties, and scattering phase functions of  
247 turbid and fluid (gas, aerosol, cloud, soots, *etc.*) volumes. (3) Mock-up: it creates the 3D mock-  
248 up of the landscape and atmosphere, assigns temperature and optical properties per scene  
249 element, and computes atmosphere vertical profiles (pressure, temperature, density). (4) Dart:  
250 it simulates the RT in the landscape and in the atmosphere with a selected modelling method  
251 and generates the requested products.

252

253 **Output data.** Two types of products are simulated. (1) Remote sensing signal:  
254 satellite/airborne/in-situ radiometric images, BRF/DBT, LiDAR signal, SIF, *etc.* (2) Radiative  
255 budget: 1D/2D/3D distribution of intercepted, absorbed, scattered and emitted (*i.e.*, thermal  
256 emission, SIF) radiation. All products can be stored per type of scene element (*e.g.*, leaf, trunk)  
257 and in a look-up-table. In addition, DART also generates geometric products such as digital  
258 surface model, area per type of scene element, leaf area index, *etc.*

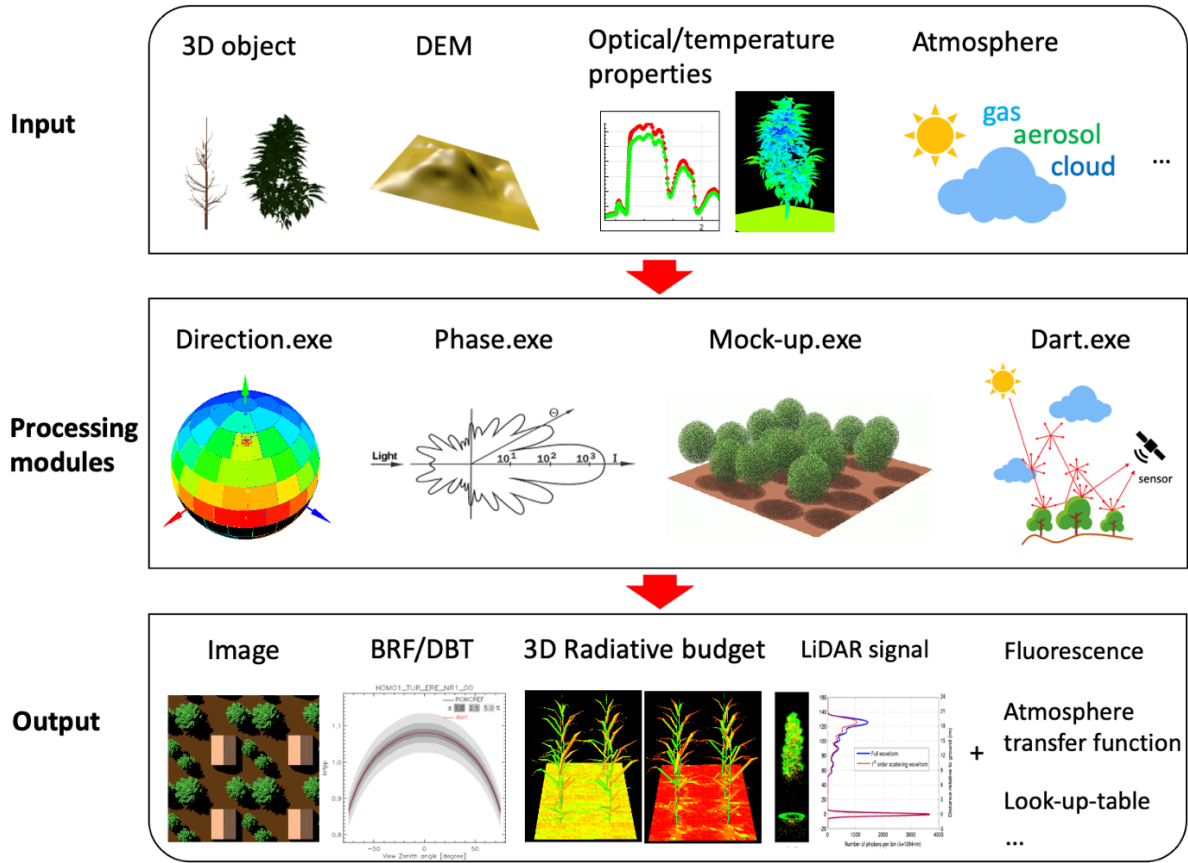

259

260 Figure 4. DART framework. Its four modules (Direction, Phase, Mock-up, Dart) simulate remote  
 261 sensing and radiative budget products for any instrumental / experimental configurations.

262

### 263 3 A new Monte Carlo method DART-Lux

#### 264 3.1 Presentation

265 Monte Carlo methods (Weinzierl, 2000) can assess the high-dimensional integral form of  $L^{(j)}$   
 266 in Eq. (8). For example, a random path  $\bar{R} \in \mathcal{D}$  sampled according to a choosing probability  
 267 density function (PDF)  $p(\bar{r})$ , can give an unbiased estimate of  $L^{(j)}$ :

$$F^{(j)} = \frac{f^{(j)}(\bar{R})}{p(\bar{R})} \quad (11)$$

268 with expected value  $\mathbb{E}(F^{(j)}) = \int_{\mathcal{D}} \frac{f^{(j)}(\bar{r})}{p(\bar{r})} p(\bar{r}) d\mu(\bar{r}) = \int_{\mathcal{D}} f^{(j)}(\bar{r}) d\mu(\bar{r}) = L^{(j)}$ .

269

270 The remote sensing images can be accurately and efficiently simulated under two conditions:  
 271 (1) path samples are generated quickly, and (2) an optimised estimator speeds up the  
 272 convergence. To meet these conditions, the new Monte Carlo method, called DART-Lux  
 273 (Figure 5) is designed based on the bidirectional path tracing (BDPT) algorithm (Lafortune and  
 274 Willems, 1993; Veach and Guibas, 1995a, 1995b). It estimates the radiance measurement  $L^{(j)}$   
 275 by sampling a set of paths and summing up their weighed contributions (Figure 5). This section  
 276 details its theoretical basis: path creation method, evaluation of radiance measurement, and its  
 277 light and sensor models.

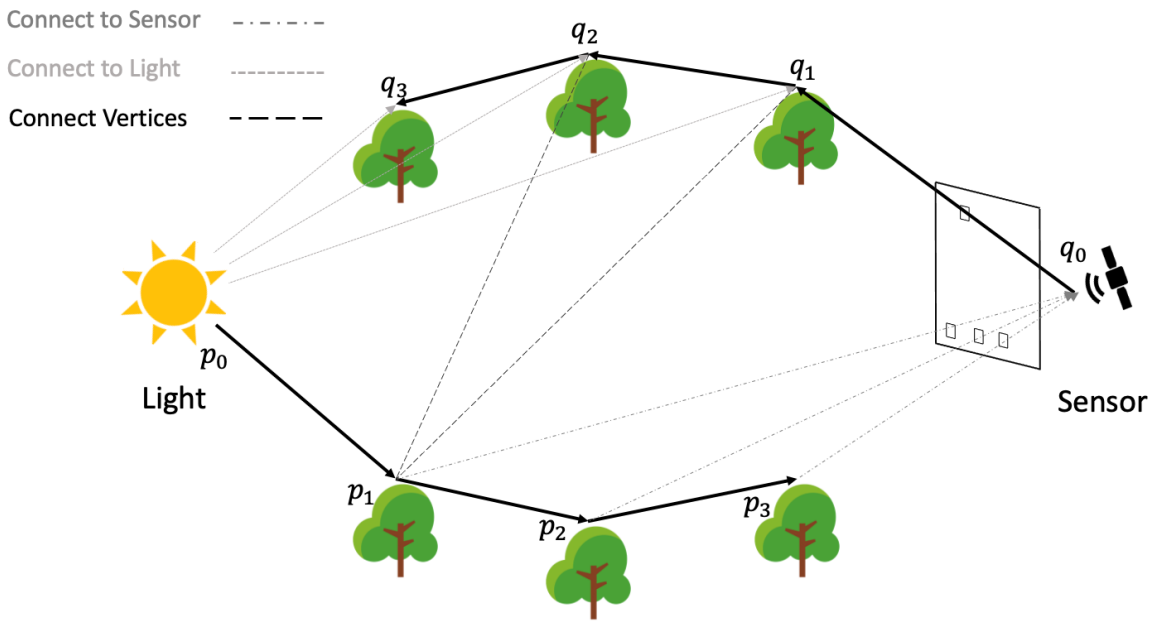

278  
 279 Figure 5. DART-Lux bidirectional path tracing with  $N_v = 4$  vertices (maximal scattering order 3).

280 Random walks start from the light source and sensor.  $\bar{p}_4 = p_0, p_1, p_2, p_3$  is a light sub-path  
 281 (random walk from light source).  $\bar{q}_4 = q_0, q_1, q_2, q_3$  is a sensor sub-path (random walk from  
 282 sensor). A set of paths is generated by connecting a vertex of light sub-path and a vertex of  
 283 sensor sub-path. An intersection test is done at each connection. Three methods can connect  
 284 vertices. 1) Connect to light: a sensor sub-path vertex is connected to a newly sampled vertex  
 285 on the light source. 2) Connect to sensor: a light sub-path vertex is connected to a newly  
 286 sampled vertex on the sensor lens and mapped to the image plane. 3) Connect vertices: a light



287 sub-path vertex in the scene is connected to a sensor sub-path vertex in the scene. Note that a  
 288 light sub-path can randomly hit the sensor lens, and a sensor sub-path can randomly hit the  
 289 light source.

290

## 291 3.2 Efficient path sampling

### 292 3.2.1 Direction and vertex sampling

293 At each scattering event, a random scattered direction is sampled according to the distribution  
 294 of scattering power due to unit incident power. Eq. (12) defines the PDF of an exit direction  $\Omega_o$   
 295 knowing the incident direction  $-\Omega_i$ , using the importance sampling method (Kahn and  
 296 Marshall, 1953). The probability of reflection  $P^*$  is 1 for opaque surfaces (transmittance  $\tau = 0$ ),  
 297 0 for non-reflective surfaces (reflectance  $\rho = 0$ ), and 0.5 otherwise ( $\rho, \tau > 0$ ) which makes the  
 298 sampling less dependent on spectral properties. The PDF  $p(\Omega_i | -\Omega_o)$  for sensor sub-path  
 299 sampling can be derived similarly.

$$p(\Omega_o | -\Omega_i) = \begin{cases} P^* \cdot \frac{\frac{\rho(r, -\Omega_i, \Omega_o)}{\pi} \cdot \cos \theta_o}{\int_{2\pi} \frac{\rho(r, -\Omega_i, \Omega'_o)}{\pi} \cdot \cos \theta'_o d\Omega'_o}, & \text{if } (\mathbf{n} \cdot \Omega_o) \cdot (\mathbf{n} \cdot \Omega_i) \geq 0 \\ (1 - P^*) \cdot \frac{\frac{\tau(r, -\Omega_i, \Omega_o)}{\pi} \cdot \cos \theta_o}{\int_{2\pi} \frac{\tau(r, -\Omega_i, \Omega'_o)}{\pi} \cdot \cos \theta'_o d\Omega'_o}, & \text{otherwise} \end{cases} \quad (12)$$

300 For a Lambertian surface (*i.e.*,  $\rho(r, -\Omega_i, \Omega_o) = \rho$ ,  $\tau(r, -\Omega_i, \Omega_o) = \tau$ ), we have:

$$p(\Omega_o | -\Omega_i) = \begin{cases} P^* \cdot \frac{\cos \theta_o}{\pi}, & \text{if } (\mathbf{n} \cdot \Omega_o) \cdot (\mathbf{n} \cdot \Omega_i) \geq 0 \\ (1 - P^*) \cdot \frac{\cos \theta_o}{\pi}, & \text{otherwise} \end{cases} \quad (13)$$

301 Once a scattering direction is sampled, an intersection test along the sampled direction  
 302 determines the next path vertex. Sections 3.4 details the vertex and direction samplings on the  
 303 light source and sensor.

304

305 **3.2.2 Bidirectional random walk**

306 By repeatedly sampling vertices in the scene, the BDPT method (Figure 5) creates two random  
 307 walks with  $N_v$  vertices each. A random walk starts from the light source and gives a light sub-  
 308 path  $\bar{p}_{N_v} = p_0, p_1, \dots, p_{N_v-1}$  with vertex  $p_0$  on the light source. A second one starts from the  
 309 sensor and gives a sensor sub-path  $\bar{q}_{N_v} = q_0, q_1, \dots, q_{N_v-1}$  with vertex  $q_0$  on the sensor lens.

310

311 **3.2.3 Path generating ways**

312 An end-to-end path  $\bar{r}_{s,t}$  is generated by connecting a light sub-path  $\bar{p}_s = p_0, p_1, \dots, p_{s-1}$  and a  
 313 sensor sub-path  $\bar{q}_t = q_0, q_1, \dots, q_{t-1}$  with  $s, t \in [0, N_v]$ .

$$\bar{r}_{s,t} = \bar{p}_s, \bar{q}_t = p_0, p_1, \dots, p_{s-1}, q_{t-1}, q_{t-2}, \dots, q_0 \quad (14)$$

314 Vertex  $q_{t-1}$  is on the light source if  $s = 0$ . Vertex  $p_{s-1}$  is on the sensor lens if  $t = 0$ . Any path  
 315 of length  $n$  (*i.e.*,  $s + t = n + 1$  vertices) can be created in  $n + 2$  ways. For example, Figure 6  
 316 shows the five ways to create a path of length 3.

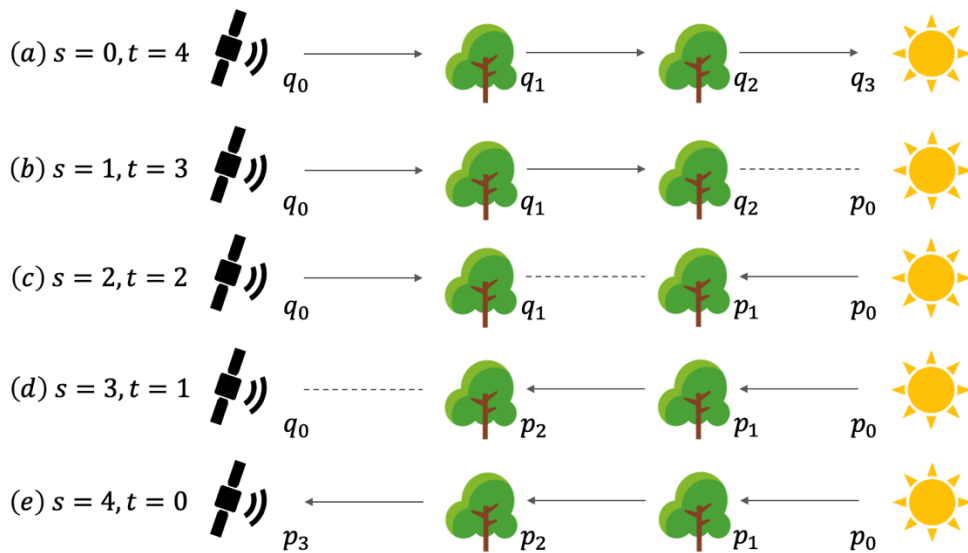

317

318 Figure 6. Five ways to generate a path of length 3. (a) Hit light: a ray starts from a sensor, is scattered  
 319 twice in the scene, then hits a light source. (b) Connect to light: a ray starts from a sensor, is  
 320 scattered once in the scene, then intersects a scene element from which a path is created by an  
 321 explicit intersection test between the intersect vertex and a light source. (c) Connect vertices: 2

322 rays start from a sensor and light source, are intercepted by the scene, and a path is created by  
 323 an intersection test between the two intersect vertices. (d) Connect to sensor: a ray starts from a  
 324 light source, is scattered once in the scene, and intersects a scene element from which a path is  
 325 created by an explicit intersection test between the intersect vertex and a sensor. (e) Hit sensor:  
 326 a ray starts from a light source, is scattered twice in the scene and hits a sensor.

327

### 328 3.3 Measurement evaluation

#### 329 3.3.1 MIS estimator of radiance measurement

330 The contribution  $C_{\mathcal{D}_{n-1}}$  of a path of length  $n$  can be estimated with Eq. (11) using one of  $n + 2$   
 331 ways (*cf.* section 3.2.3). For example, the backward light transport applies the “connect to light”  
 332 way (Figure 6.(b)), and the forward light transport applies the “connect to sensor” way (Figure  
 333 6.(d)). However, the performance of path generation depends on the light source and sensor  
 334 configurations, surface scattering properties, as well as the 3D structure of the landscape. For  
 335 example, the “hit light” way is not efficient for sunlight because the probability to hit the sun  
 336 is very small, while it is efficient for diffuse light from the sky. The “connect to light” way is  
 337 efficient for Lambertian surfaces and not efficient for glossy surfaces. Hence, to robustly handle  
 338 a variety of scenarios, contributions of the  $n + 2$  ways are weighted and summed. For example,  
 339 in the “hit light” case, we can assign a small weight if the light source is sunlight and assign a  
 340 larger weight if the light source is the sky. This combined weighting method, called the multiple  
 341 importance sampling (MIS) (Veach and Guibas, 1995b), uses a MIS weight  $w_{s,t}$  per path  $\bar{r}_{s,t}$ :

$$F_{\text{MIS}}^{(j)} = \sum_{s \geq 0} \sum_{t \geq 0} w_{s,t}(\bar{r}_{s,t}) \cdot \frac{f^{(j)}(\bar{r}_{s,t})}{p(\bar{r}_{s,t})} \quad (15)$$

342 Two conditions must be met to get an unbiased estimate for path of length  $n$ :

$$343 \sum_{s=0}^{n+1} \sum_{t=n-s+1} w_{s,t}(\bar{r}_{s,t}) = 1 \text{ if } f^{(j)}(\bar{r}_{s,t}) \neq 0, \text{ and } w_{s,t}(\bar{r}_{s,t}) = 0 \text{ if } p(\bar{r}_{s,t}) = 0.$$

344

345 Eq. (15) gives the radiance measurement of infinite scattering order although infinite scattering  
 346 order cannot be simulated explicitly. Usually, the contribution  $C_{D_n}$  in Eq. (10) decreases  
 347 exponentially with scattering order (Kallel, 2018). If after scattering order  $M$  ( $M$  depends on  
 348 spectral band, landscape complexity and scene optical properties), the contribution of higher  
 349 scattering order is negligible, *i.e.*,  $\varepsilon_M = \sum_{n=M+2}^{\infty} C_{D_n} \ll L^{(j)}$ , and we use the approximation:

$$L^{(j)} = C_{D_1} + C_{D_2} + \dots + C_{D_{M+1}} \quad (16)$$

350 The maximal scattering order  $M$  is a DART parameter: paths of length larger than  $M + 1$  are  
 351 ignored, which is consistent with scattering order  $M$ . The MIS estimator of  $L^{(j)}$  in Eq. (16) is:

$$F_{\text{MIS}}^{(j)} = \sum_{n=1}^{M+1} \sum_{s=0}^{n+1} w_{s,t}(\bar{r}_{s,t}) \cdot \frac{f^{(j)}(\bar{r}_{s,t})}{p(\bar{r}_{s,t})} \quad (17)$$

352 with

$$w_{s,t}(\bar{r}_{s,t}) = \frac{\left(p(\bar{r}_{s,t})\right)^2}{\sum_{s'=0, t'=n-s'+1}^{n+1} \left(p(\bar{r}_{s',t'})\right)^2} \quad (18)$$

353 Here  $s + t = s' + t' = n + 1$  is always ensured. Appendix C details the incremental  
 354 computation of Eq. (18) along the random walk.

355

### 356 3.3.2 Computation of unweighted contribution $\frac{f^{(j)}(\bar{r}_{s,t})}{p(\bar{r}_{s,t})}$

357 The so-called “unweighted contribution” is the estimate of corresponding path generating way

358 (*cf.* section 3.2.3) using Eq. (11), *i.e.*,  $\frac{\text{measurement contribution function } f^{(j)}(\bar{r}_{s,t})}{\text{path PDF } p(\bar{r}_{s,t})}$ .

359

360 **Measurement contribution function  $f^{(j)}(\bar{r}_{s,t})$ .** It is the integrand in Eq. (8).

$$\begin{aligned} f^{(j)}(\bar{r}_{s,t}) = & L_e(p_0 \rightarrow p_1) \cdot T(\bar{p}_s) \cdot f(p_{s-2} \leftrightarrow p_{s-1} \leftrightarrow q_{t-1}) \cdot G(p_{s-1} \leftrightarrow q_{t-1}) \\ & \cdot f(p_{s-1} \leftrightarrow q_{t-1} \leftrightarrow q_{t-2}) \cdot T(\bar{q}_t) \cdot W_e^{(j)}(q_0 \rightarrow q_1) \end{aligned} \quad (19)$$

361 with throughputs  $T(\bar{p}_s)$  and  $T(\bar{q}_t)$  computed incrementally along the random walks:

$$\begin{aligned}
 T(\bar{p}_s) &= \prod_{k=1}^{s-1} f(p_{k-2} \leftrightarrow p_{k-1} \leftrightarrow p_k) \cdot G(p_{k-1} \leftrightarrow p_k) \\
 T(\bar{q}_t) &= \prod_{k=1}^{t-1} f(q_k \leftrightarrow q_{k-1} \leftrightarrow q_{k-2}) \cdot G(q_{k-1} \leftrightarrow q_k)
 \end{aligned} \tag{20}$$

362 The virtual BSDFs  $f(p_{-1} \leftrightarrow p_0 \leftrightarrow p_1)$  and  $f(q_1 \leftrightarrow q_0 \leftrightarrow q_{-1})$  are introduced to simplify the  
 363 mathematical formulation. They are set to 1.  $f(\bar{r}_{0,t}) = L_e(q_{t-1} \rightarrow q_{t-2}) \cdot T(\bar{p}_t) \cdot W_e^{(j)}(q_0 \rightarrow$   
 364  $q_1)$  if  $s = 0$  and  $f(\bar{r}_{s,0}) = L_e(p_0 \rightarrow p_1) \cdot T(\bar{p}_s) \cdot W_e^{(j)}(p_{s-1} \rightarrow p_{s-2})$  if  $t = 0$ .

365

366 **Path probability density  $p(\bar{r}_{s,t})$ .** In the random walk (*i.e.*, Monte Carlo Markov chain), a  
 367 stochastic exit direction depends only on the local incident direction. As a result, the PDF  
 368  $p(p_k | p_{k-1}, p_{k-2})$  of vertex  $p_k$  depends only on the two previous vertices  $p_{k-1}$  and  $p_{k-2}$  and  
 369 the PDF of a path is the product of the PDF of all its vertices (Eq. (21)).

$$p(\bar{r}_{s,t}) = p(\bar{p}_s) \cdot p(\bar{p}_t) = \prod_{k=0}^{s-1} p(p_k | p_{k-1}, p_{k-2}) \cdot \prod_{k=0}^{t-1} p(q_k | q_{k-1}, q_{k-2}) \tag{21}$$

370

## 371 3.4 Light and sensor models

### 372 3.4.1 light sources

373 DART-Lux is flexible to integrate a variety of light sources (*e.g.*, sun, sky, moon, LiDAR).  
 374 Here, the modelling of sunlight and light from the sky is presented. The light from the sky is  
 375 the light scattered downwards by the atmosphere. If more than one light source is simulated,  
 376 the light sources are sampled according to their power. The sunlight can be parallel or within a  
 377 cone and the sky light can be isotropic or anisotropic. In both cases, light is uniformly emitted  
 378 from a virtual disk  $A_{\text{disk}}$  that is the projection of the scene sphere along the illumination

379 direction, *i.e.*, PDF of the first vertex on the light source is  $p(p_0) = \frac{1}{A_{\text{disk}}}$ . The so-called scene  
380 sphere is the sphere with minimum radius  $R$  that encloses all the scene (Figure 7). The light  
381 direction is sampled according to the energy angular distribution. The emitted radiance  
382  $L_e(p_0, \Omega_0)$  is always determined by the relationship  $E_{\text{BOA}} = \int L_e(p_0, \Omega_0) \cdot \cos \theta_0 d\Omega_0$  where  
383  $E_{\text{BOA}}$  is the bottom of atmosphere (BOA) irradiance of the light source. Compared to the  
384 commonly used strategy in which the light is emitted from the horizontal plane at the scene top  
385 as in (North, 1996; Thompson and Goel, 1998), this method is more robust, since it ensures that  
386 the scene can be fully illuminated along any light direction even with strong sloping topography.

387

388 **Sunlight.** If sunlight (solar direction  $\Omega_s$ ) is parallel, the direction PDF is interpreted as a Dirac

389 delta function  $p(\Omega_0) = \delta(\Omega_0 - \Omega_s)$ . The emitted radiance is  $L_e(p_0, \Omega_0) = \frac{E_{\text{BOA}}^{\text{dir}}}{\cos \theta_s} \cdot \delta(\Omega_0 - \Omega_s)$ ,

390 where  $E_{\text{BOA}}^{\text{dir}}$  is the direct irradiance at BOA. If the penumbra is simulated, the direction  $\Omega_0$  is

391 uniformly sampled within solid angle  $\Delta\Omega = \frac{A_{\text{sun}}}{(1 \text{ AU})^2}$  ( $A_{\text{sun}}$  is the solar disk area, 1 AU is the

392 distance from the Earth to sun). Then, the emitted radiance is  $L_e(p_0, \Omega_0) = \frac{E_{\text{BOA}}^{\text{dir}}}{\cos \theta_s \cdot \Delta\Omega}$ .

393

394 **Light from the sky.** If it is isotropic, the direction PDF follows a cosine distribution  $p(\Omega_0) =$

395  $\frac{\cos \theta}{\pi}$ . The emitted radiance is  $L_e(p_0, \Omega_0) = \frac{E_{\text{BOA}}^{\text{diff}}}{\pi}$ , where  $E_{\text{BOA}}^{\text{diff}}$  is the diffuse irradiance at BOA.

396 If it is anisotropic, the direction PDF and the emitted radiance is computed according to the

397 energy distribution as described in (Wang and Gastellu-Etchegorry, 2021).

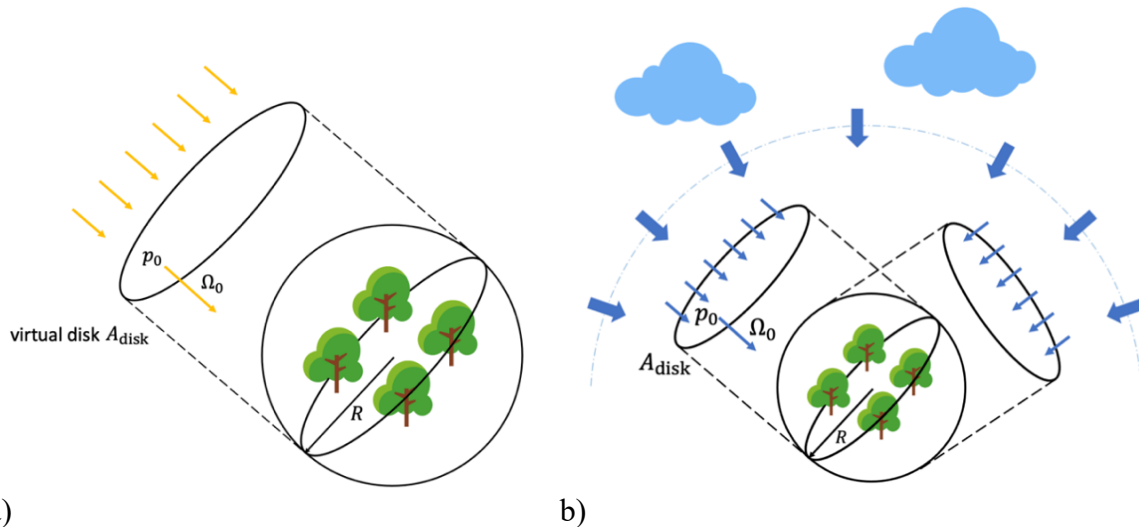

a)

b)

398 Figure 7. Scene illumination of a) Parallel sunlight and b) diffuse light from the sky. The Earth scene  
 399 is in a scene sphere with radius  $R$ . Sunlight or light from the sky originates from a virtual disk  
 400 that is the projection of the scene sphere along the illumination direction.

401

### 402 3.4.2 Sensors

403 The two common remote sensing sensors, *i.e.*, pinhole camera and orthographic camera, are  
 404 implemented. The pinhole camera has an infinitesimal lens. It is used to simulate airborne and  
 405 in-situ observations with infinite depth of field. The orthographic camera has an infinitesimal  
 406 field of view (FOV). It is used to simulate satellite images. For both cameras, the random walk  
 407 starts by sampling a random vertex on the lens  $A_0$  and a direction in the FOV. The computation  
 408 of importance  $W_e$  is detailed in appendix A. In addition, a special camera, called BRF camera,  
 409 is designed for an efficient simulation of the scene albedo, BRF and DBT.

410

411 **Pinhole camera** (Figure 3). The pinhole is at a distance  $f$  in front of the image plane  $A_{\text{img}}$ . The  
 412 vertex on the lens is sampled by a Dirac delta function  $p(q_0) = \delta(q_0 - q_d)$ , with  $q_d$  the pinhole  
 413 position. The direction is obtained by uniformly sampling a vertex  $q_{\text{img}}$  on the image plane and

414 connect  $q_0$  on the lens. Since the lens does not refract rays, the directional PDF is derived from

415 the relationship  $p(\Omega_0) = p(q_{\text{img}}) \cdot \frac{\left(\frac{f}{\cos \theta_i^{q_0}}\right)^2}{\cos \theta_i^{q_0}} = \frac{f^2}{A_{\text{img}} \cdot \cos^3 \theta_i^{q_0}}$ .

416

417 **Orthographic camera** (Figure 8). It captures parallel radiation perpendicular to the image  
 418 plane. Hence, the lens has the same shape as the image ( $A_0 \equiv A_{\text{img}}$ ). The vertex on the lens is

419 uniformly sampled with PDF  $p(q_0) = \frac{1}{A_0}$  and the direction is sampled by a Dirac delta function

420  $p(\Omega_0) = \delta(\Omega_0 - \Omega_d)$  with  $\Omega_d$  the orientation of the camera.

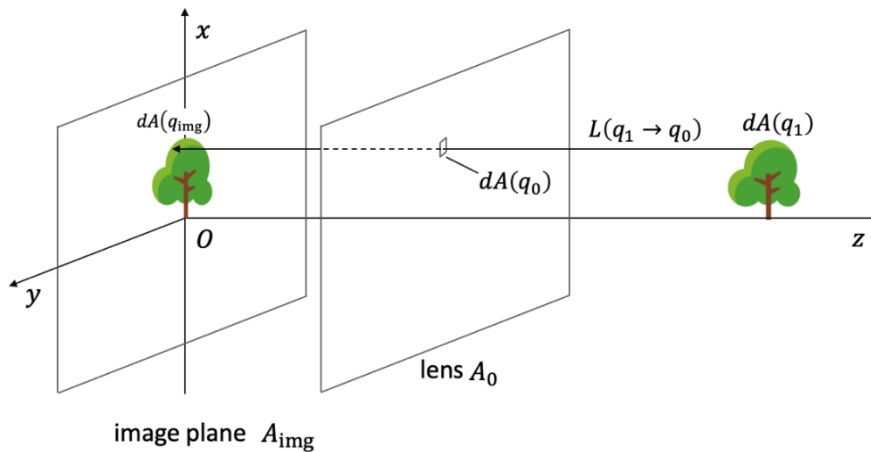

421

422 Figure 8. Orthographic camera. Lens with area  $A_0$  is placed in front of the image plane  $A_{\text{img}}$  ( $A_0 \equiv$

423  $A_{\text{img}}$ ). Radiation from a differential surface  $dA(q_1)$  in the scene along direction  $q_1 \rightarrow q_0$  is

424 focused by the lens onto the differential surface  $dA(q_{\text{img}})$  at the image plane.

425

426 **BRF camera.** It is designed for BDPT algorithm to give the scene exit radiance. Its hemispheric  
 427 image plane is an array of pixels that capture the scene upward radiation along a solid angle

428  $\Delta\Omega = \int_{\Delta\varphi} \int_{\Delta\theta} \sin \theta d\theta d\varphi$  (Figure 9.b). Each pixel stores the scene average radiance along a

429 direction  $\Omega_0(\Delta\Omega)$ . An exit direction is sampled with:



$$p(\Omega_0) = \frac{p(\theta, \varphi)}{\sin \theta}, \text{ with } \begin{cases} p(\theta) = \frac{1}{\pi/2} \\ p(\varphi) = \frac{1}{2\pi} \end{cases} \quad (22)$$

430 Then, the vertex on the lens is uniformly sampled on the scene ortho-projected surface

431  $A_{\text{ortho}}(\Omega_0)$  (Figure 9.a) along the viewing direction  $\Omega_0$  with PDF  $p(q_0) = \frac{1}{A_{\text{ortho}}(\Omega_0)}$ .

432

433 Compared to the photon spread method (Thompson and Goel, 1998) commonly implemented

434 in forward light transport code, such as SPRINT and Rayspread, the BRF camera offers two

435 advantages: (1) it is flexible to implement in Monte Carlo codes (*e.g.*, forward, backward and

436 bi-directional light transport), and (2) the mean radiance/reflectance of any direction with any

437 solid angle can be derived in a postprocess once the camera pixel values are computed.

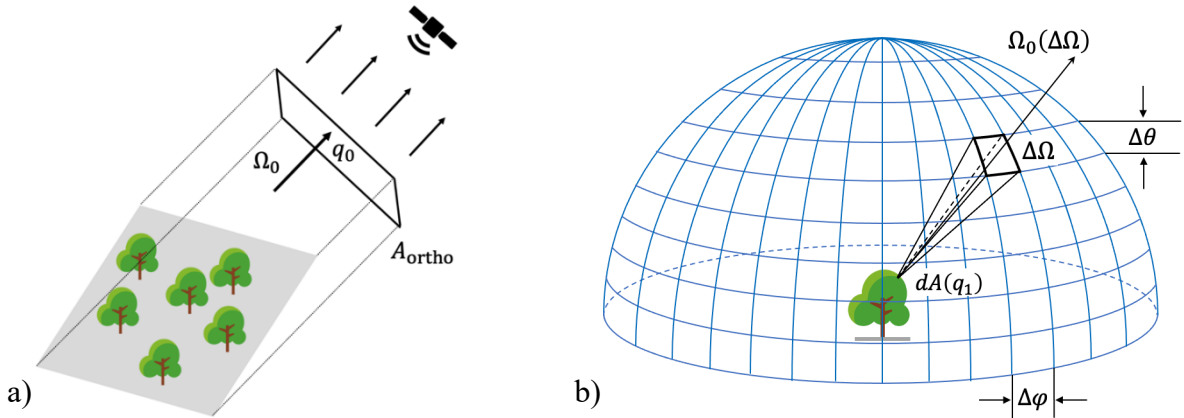

438

439 Figure 9. a) Exit radiation of a landscape along direction  $\Omega_0$  captured by a “specific” orthographic

440 camera with image plane  $A_{\text{ortho}}(\Omega_0)$ . b) The hemispheric image plane of the BRF camera.

441

#### 442 4 Comparison with standard DART-FT

443 Here, DART-Lux accuracy for BRF and remote sensing images is assessed using DART-FT as

444 a reference. Indeed, as indicated in section 2.2, DART-FT accuracy is  $\sim 0.02$  for reflectance, <

445 2 K for brightness temperature and  $\sim 1\%$  compared to benchmark RT models. Three scenes are  
 446 considered: schematic scene, urban scene and forest scene.

447

#### 448 4.1 Schematic scene

449 The schematic scene (Figure 10) has seven cherry trees with different sizes and a DART-created  
 450 house with gable roof to assess DART-Lux accuracy in presence of slopes. Its mock-up consists  
 451 of 0.137 million facets. Table 1 and Table 2 give DART input parameters. Its BOA images are  
 452 simulated for four spectral bands (blue B:  $0.44 \mu\text{m}$ ; green G:  $0.56 \mu\text{m}$ ; red R:  $0.66 \mu\text{m}$ ; near  
 453 infrared NIR:  $0.87 \mu\text{m}$ ) at  $0.125\text{m}$  spatial resolution, for three light conditions (*i.e.*, single and  
 454 multiple light sources) with  $\text{SKYL} = \frac{\text{BOA sky diffuse irradiance}}{\text{BOA total irradiance}}$  equal to 0 (direct sun), 1 (diffuse  
 455 sky) and 0.5 (direct sun + diffuse sky).

456

457 Table 1. Input parameters for the mock-up, light source and spectral band.

Parameters		Value
<b>DART scene</b>	Scene dimension	$X = Y = 32 \text{ m}$
	Spatial resolution	$\Delta x = \Delta y = 0.125 \text{ m}$
	Tree model	Cherry tree
	Building model	DART classic house
	Neighborhood effect	Repetitive mode
<b>Sunlight</b>	Direction	Zenith angle $\theta_{\text{sun}} = 30^\circ$ , Azimuth angle $\varphi_{\text{sun}} = 225^\circ$
	TOA irradiance	THKUR (Berk et al., 2008)
<b>Sky light</b>	SKYL	0, 0.5 or 1
<b>Spectral band</b>	Spectral band	$0.44 \mu\text{m}$ , $0.56 \mu\text{m}$ , $0.66 \mu\text{m}$ , $0.87 \mu\text{m}$
	Bandwidth	$0.02 \mu\text{m}$

458

459 Table 2. Configurations of DART-Lux and DART-FT RT methods.

DART-Lux		DART-FT	
Samples/pixel	400	Discrete direction	1000
Max scattering order	6	Max scattering order	6
Number of threads	8	Number of threads	8
		Illumination rays per pixel	169

460

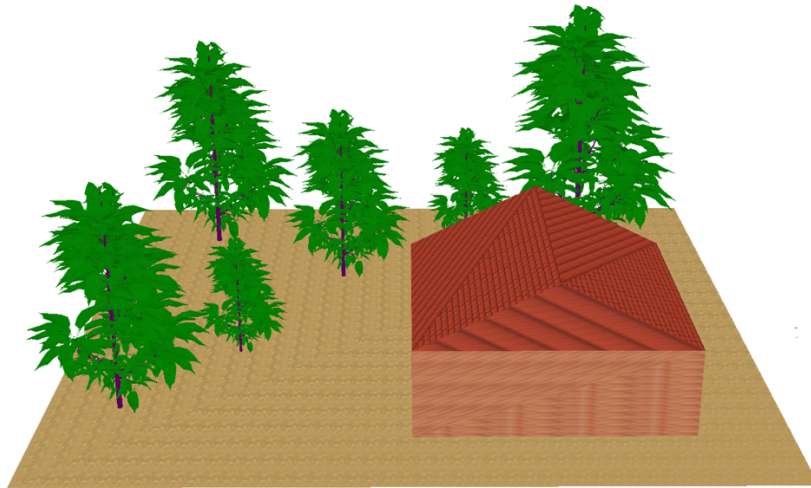

461

462 Figure 10. Mock-up of the schematic scene: 7 cherry trees of different sizes and a DART classic house.

463

464 The consistency of DART-Lux and DART-FT images is illustrated by the visual comparison  
465 of their RGB colour composite images (Figure 11) and by the scatter plots of their NIR  
466 reflectance (Figure 12) for the three BOA illumination conditions. Degrading the image  
467 resolution from 0.125m to 0.5 m greatly improves the pixelwise comparison from  $\{R^2 > 0.968,$   
468  $\text{bias} < 0.006\}$  to  $\{R^2 > 0.995, \text{bias} < 0.0004\}$  because it mitigates the noise and discretization  
469 effects. Figure 13 shows the BRF profiles in the solar plane for the four spectral bands (B, G,  
470 R, NIR), with viewing zenith angle step  $\Delta\theta_v = 5^\circ$ . Differences are quantified by the average

471 absolute relative difference  $\bar{\varepsilon} = \frac{1}{N_{\theta_v}} \sum_{\theta_v} \left| \frac{\rho_{\text{DART-LUX}}(\theta_v) - \rho_{\text{DART-FT}}(\theta_v)}{\rho_{\text{DART-FT}}(\theta_v)} \right| \cdot 100\%$  with  $N_{\theta_v}$  the  
 472 number of viewing directions. Usually,  $\bar{\varepsilon} \approx 0.4\%$  (Table 3) and maximal  $\bar{\varepsilon}_{\text{max}} \approx 0.6\%$ . The  
 473 slight differences in the scatter plot and the BRF profile are mostly due to DART-Lux Monte  
 474 Carlo noise and DART-FT discretization processes. Indeed, even with 1000 discrete directions,  
 475 the DART-FT “atmosphere shadows” (*i.e.*, SKYL = 1) have a discrete aspect less realistic than  
 476 that with DART-Lux.

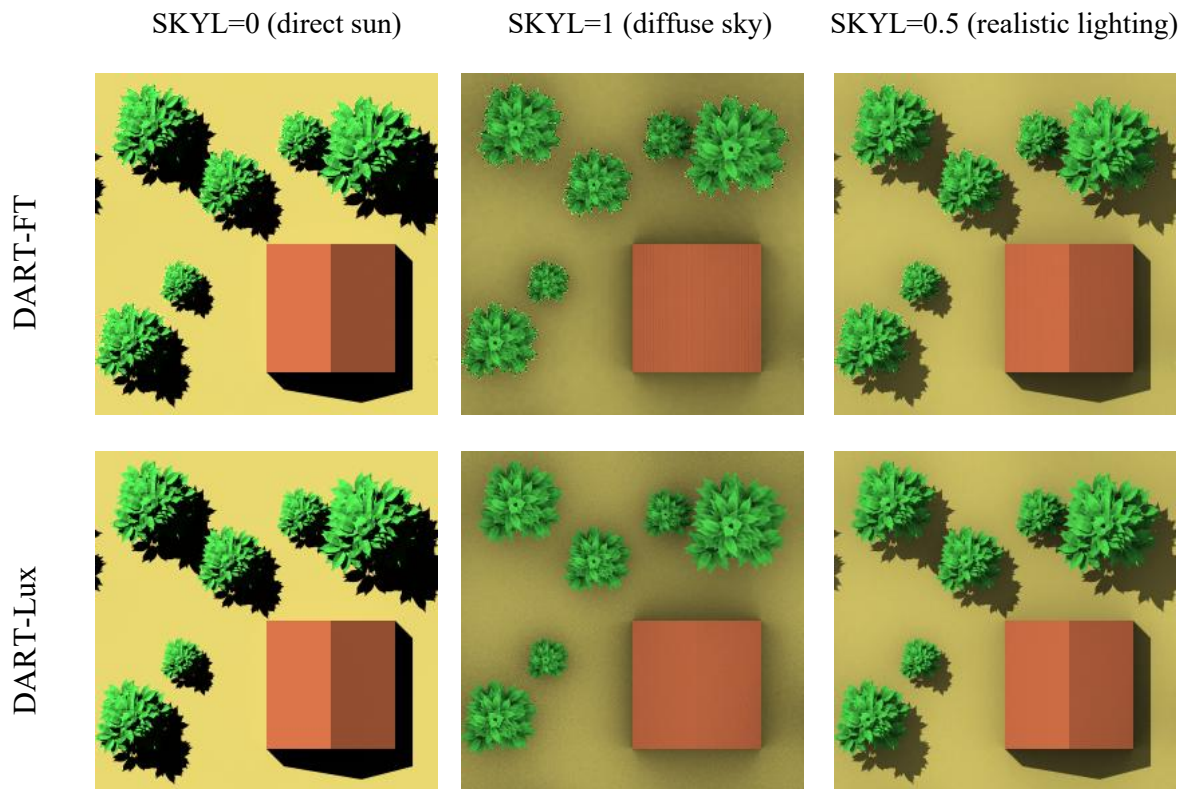

477 Figure 11. DART-FT (top) and DART-Lux (bottom) RGB images for three light conditions: SKYL=0  
 478 (left), SKYL=1 (centre) and SKYL=0.5 (right).

SKYL = 0

SKYL = 1

SKYL = 0.5

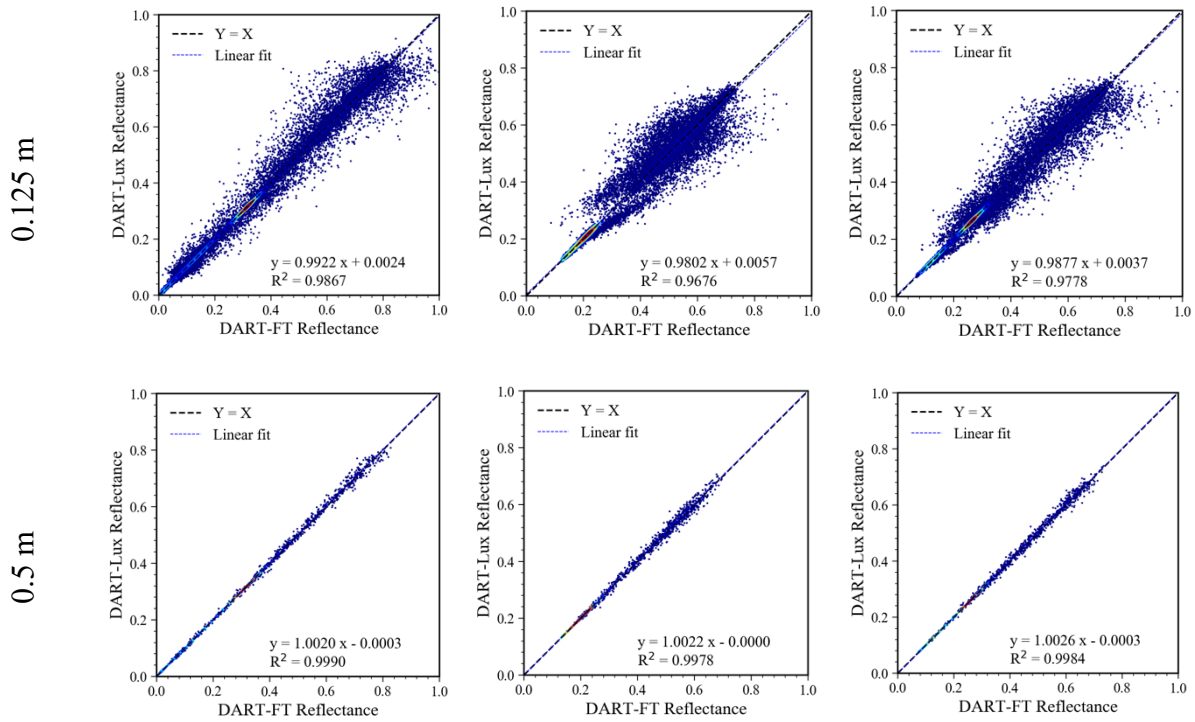

479 Figure 12. Pixelwise comparison of DART-FT and DART-Lux NIR reflectance. Pixel values  
 480 at 0.5 m resolution result of the degradation of the initial image at 0.125 m resolution.

481

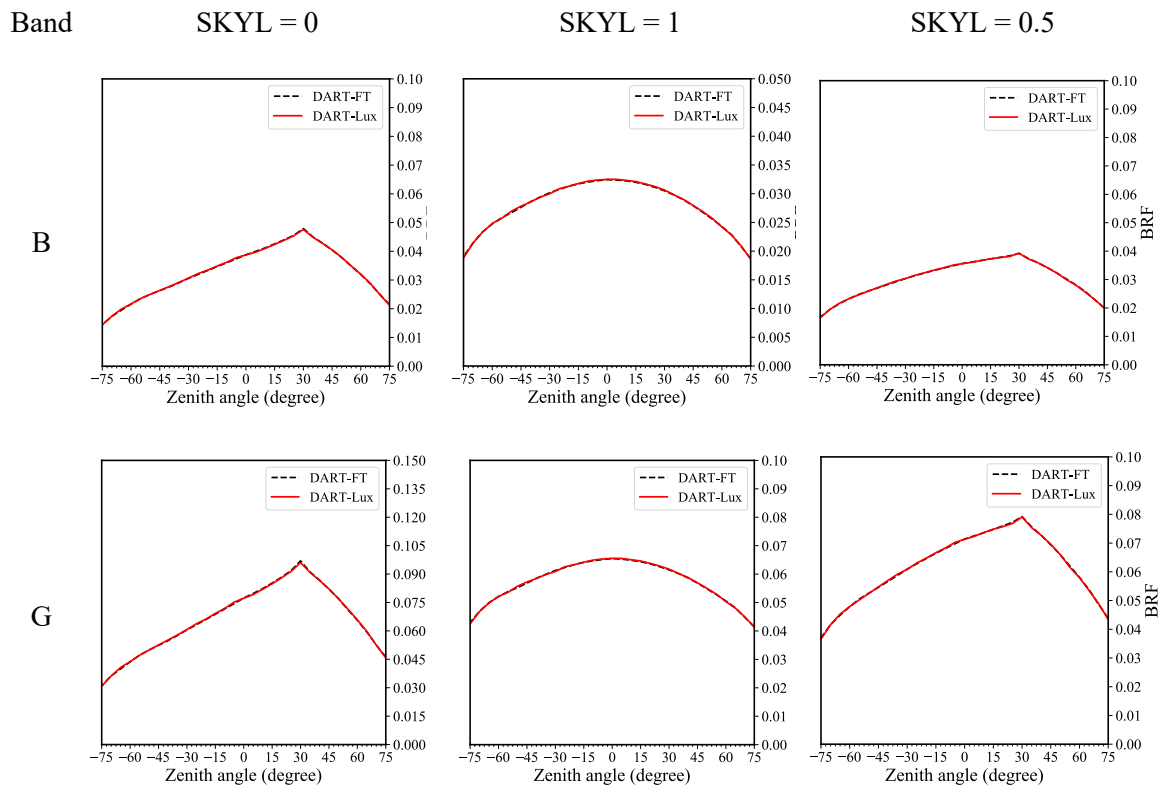

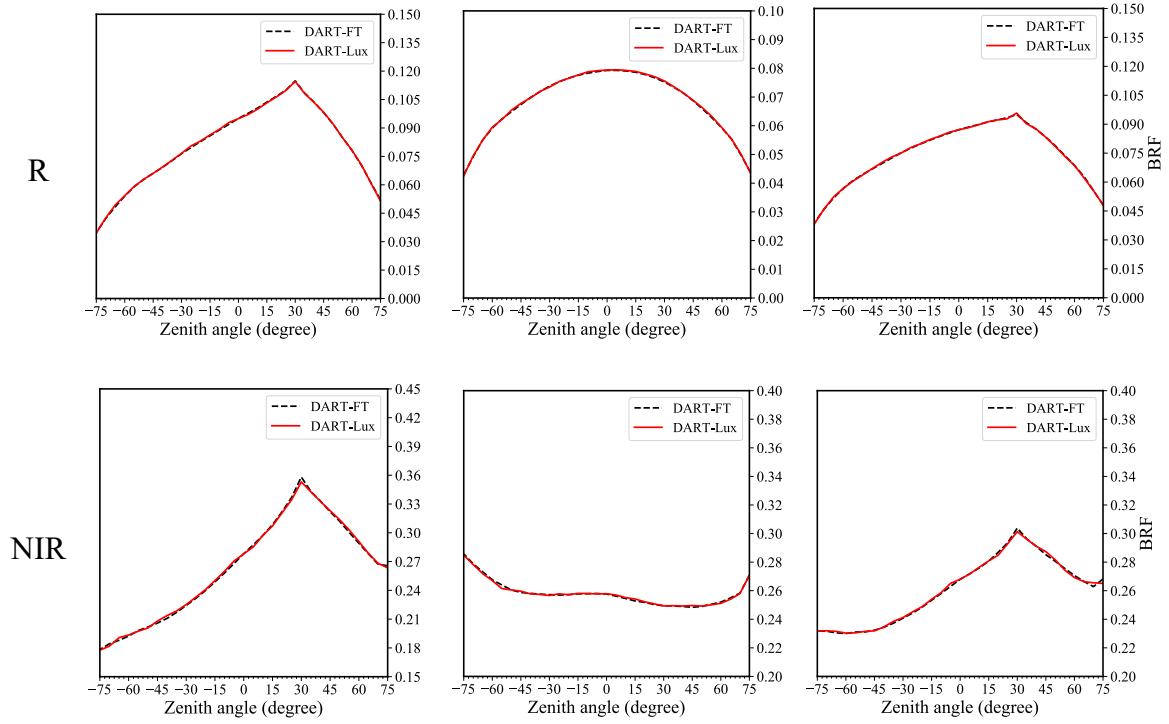

482 Figure 13. DART-FT and DART-Lux solar plane reflectance ( $\Delta\theta_v = 5^\circ$ ) in four spectral bands (R, G,  
 483 B, NIR) for three illuminations (SKYL=0, SKYL=1, SKYL=0.5).

484

485 Table 3. Summary of average absolute relative difference  $\bar{\epsilon}$  of BRF in Figure 13.

Band	SKYL = 0	SKYL = 1	SKYL = 0.5
B	0.443	0.335	0.360
G	0.467	0.336	0.359
R	0.445	0.349	0.404
NIR	0.605	0.226	0.338

486

## 487 4.2 Urban scene

488 The urban scene is the Brienne district (1400 m  $\times$  750 m) of Toulouse, France. Its 3D mock-  
 489 up (Figure 14.a) was provided by the Toulouse townhall. It contains 953 buildings, 2433 trees,  
 490 3 grasslands, 1 river, 1 canal and other city facilities, represented by 8 million facets. DART-  
 491 FT and DART-Lux are configured with direct sun light ( $\theta_{\text{sun}} = 20^\circ$ ,  $\varphi_{\text{sun}} = 180^\circ$ , SKYL = 0),

492 0.5 m spatial resolution, four spectral bands (B: 0.44  $\mu\text{m}$ , G: 0.55  $\mu\text{m}$ , R: 0.66  $\mu\text{m}$ , NIR: 0.87  
493  $\mu\text{m}$ ), maximal scattering orders 6, no topography, and no atmosphere. Common optical  
494 properties are assigned per type of urban element (e.g., roof, vegetation). DART-FT is run with  
495 100 discrete directions and 100 illumination rays per pixel. DART-Lux is run with 60 samples  
496 per pixel.

497  
498 DART-FT and DART-Lux RGB images are very close as illustrated by their RGB colour  
499 composites (Figure 14) and scatter plot of pixel reflectance in R band at 0.5m resolution (Figure  
500 15.a):  $R^2 > 0.99$  and bias  $\sim 0.0001$ . Degrading image resolution down to 2.0 m improves their  
501 similarity:  $R^2 > 0.999$  and bias  $< 0.0001$  (Figure 15.b). Figure 15.c shows the R band BRF in the  
502 solar plane with zenith angle step  $\Delta\theta_v = 2^\circ$ . Its average absolute relative difference  $\bar{\epsilon}$  is 0.24%.

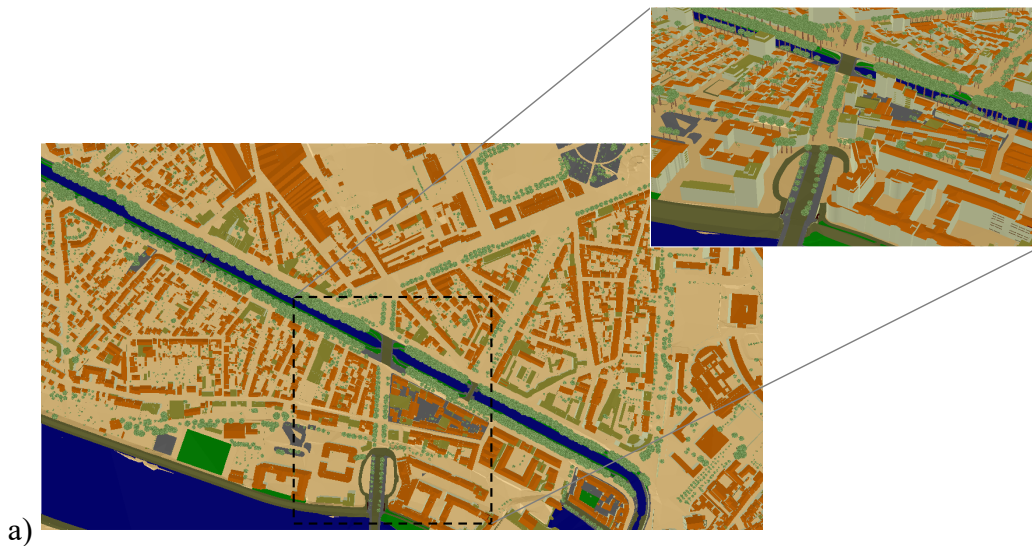



503 Figure 14. Brienne district: 3D mock-up (1400 m × 750 m) (a) and its DART-FT (b) and DART-Lux  
 504 (c) RGB images.

505

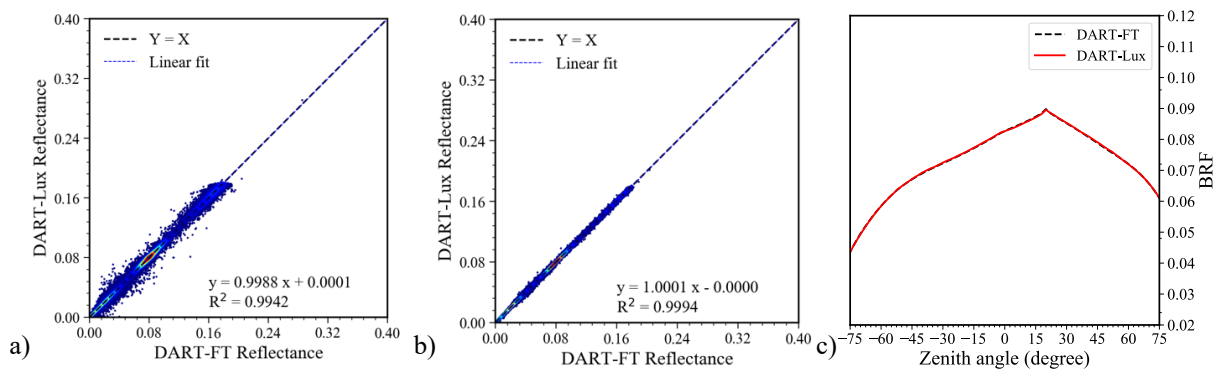



506 Figure 15. DART-Lux and DART-FT reflectance in R band. Scatter plot of pixel reflectance for 0.5  
507 m (a) and 2.0 m (b) spatial resolution. c) Reflectance in the solar plane.

508

### 509 4.3 Forest scene

510 The forest scene is the Järvelja summer birch forest (summer, HET09\_JBS\_SUM) of RAMI4  
511 experiment (<https://rami-benchmark.jrc.ec.europa.eu>). It has 1029 realistic trees with 465 birch  
512 trees, 196 common alder trees, 185 aspen trees, 78 linden trees, 39 spruce trees, and 46 ash and  
513 maple trees (Figure 16). Its mock-up is created by repeating and/or rotating 18 individual 3D  
514 tree objects. For example, the 465 birch trees are generated by cloning and/or rotating 4 birch  
515 tree objects at different growing stages. This forest stand is very challenging for 3D RT models  
516 (Figure 3 in (Widlowski et al., 2015)) because it consists of more than 550 million facets.

517

518 Simulations are for direct sun illumination ( $\theta_{\text{sun}} = 36.6^\circ$ ,  $\varphi_{\text{sun}} = 270.69^\circ$ , SKYL=0), 0.125 m  
519 spatial resolution, 4 spectral bands (B: 0.44  $\mu\text{m}$ , G: 0.55  $\mu\text{m}$ , R: 0.66  $\mu\text{m}$ , NIR: 0.87  $\mu\text{m}$ ),  
520 maximal scattering order 6, and specific optical properties are assigned per tree species. DART-  
521 Lux is run with 200 samples per pixel. DART-FT is run with 62500 illumination rays per pixel,  
522 and 80 discrete directions. Figure 16.b shows DART-FT and DART-Lux RGB color composite  
523 images. As for the schematic and urban cases, the scatter plots of pixel NIR reflectance indicate  
524 that the pixelwise comparison greatly improves from 0.125 m spatial resolution (Figure 16.d):  
525  $\{R^2 > 0.93, \text{bias} \approx 0.01\}$  to 1 m spatial resolution (Figure 16.e):  $\{R^2 > 0.997, \text{bias} < 0.002\}$ .

526

527 Figure 16.f shows DART-FT and DART-Lux NIR reflectance in the solar plane, at first order  
528 scattering. DART-FT is run with and without an acceleration technique: rays that exit a cell  
529 face along a same direction are not merged (approximate case called DART-FT) or merged  
530 (accurate case called DART-FT-REF, used as a reference). DART-Lux average absolute

531 relative difference is  $\bar{\epsilon} = 0.5\%$  for DART-FT-REF and  $0.7\%$  for DART-FT. Larger differences  
 532 occur at the hot spot direction. DART-FT underestimates the hot spot (Figure 16.f) because its  
 533 merging technique reduces the exactly backscattered rays. Multiple scattering is only simulated  
 534 with DART-FT and DART-Lux because DART-FT-REF is very time and memory consuming.  
 535 The average absolute difference  $\bar{\epsilon}$  between DART-Lux and DART-FT is  $1.0\%$  (Figure 16.g).

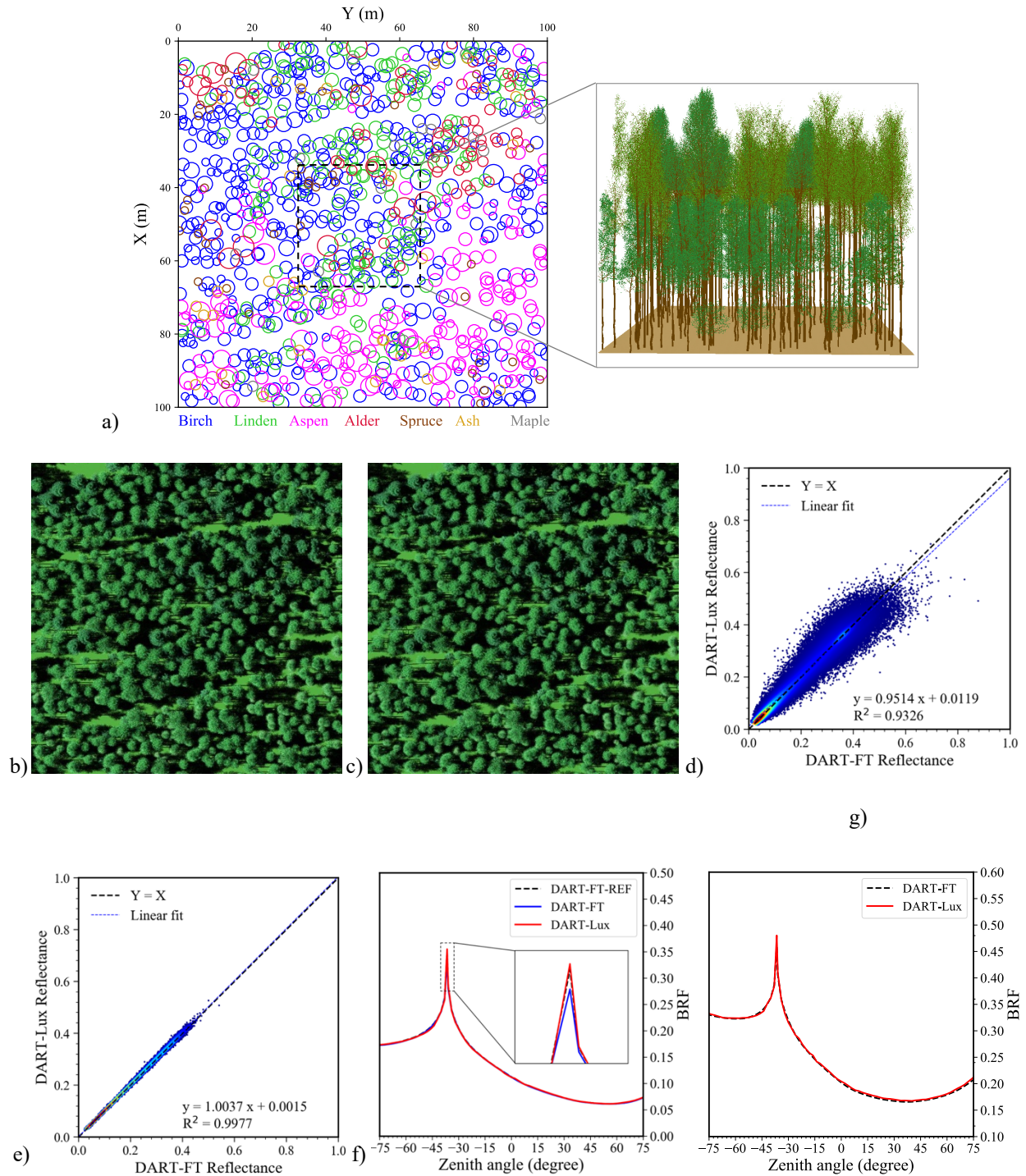

536 Figure 16. Järvselja birch forest. a) Location of trees and 3D mock-up of the centre region. DART-FT  
537 (b) and DART-Lux (c) RGB images at resolution 0.125 m. Scatter plot of pixel NIR reflectance  
538 at resolution 0.125 m (d) and 1.0 m (e). DART-FT and DART-Lux NIR reflectance in the  
539 solar plane with zenith angle step  $\Delta\theta_v = 2^\circ$ : f) single scattering reflectance, g) total reflectance.  
540

## 541 5 Discussion

### 542 5.1 Correlation of path samples

543 The BDPT (*cf.* section 3.2) with  $N_v$  vertices per random walk is very efficient because it creates  
544  $N_v^2$  paths with only  $N_v^2 + 2(N_v - 1)$  intersection tests, compared to  $N_v^3$  if each path is created  
545 independently. Knowing that the intersection test is the most computational expensive process  
546 in 3D RT modelling, the BDPT decreases simulation time by a factor  $\frac{N_v^3}{N_v^2 + 2(N_v - 1)}$ . However, it  
547 increases the covariance (*i.e.*, Monte Carlo noise) between path samples, because they are  
548 created with the same light and sensor sub-paths. Although the MIS estimator gives unbiased  
549 results (*cf.* appendix D), compared to estimates with independent path samples, the path sample  
550 correlation can increase the overall variance by a maximal factor  $f$ . With  $\tau \approx \frac{c_{D_n}}{c_{D_{n+1}}}$  ( $0 \leq \tau <$   
551 1) the average ratio of contributions of successive scattering orders (*cf.* appendix E), we have:

$$f(\tau) = \frac{(1 + \tau) \cdot \left( 2 + \tau \left( \frac{\sqrt{2}}{2} - \tau \right) (3 - \tau) \right)}{(1 - \tau)^2} \quad (23)$$

553  
554 Figure 17.a shows the decrease in the contribution of the scene radiance of scattering order  $n = 1$   
555 to 6, relative to the contribution of first order scattering, for the three scenes studied in section  
556 4. The trendiness is an exponentiation  $g(n) = \tau^{-(n-1)}$  with  $\tau$  that in  $[0, 0.1]$  for most simulations  
557 in visible bands and in  $[0.4, 0.6]$  for most simulations in the NIR band.  $f(\tau)$  of Eq. (23) (Figure

558 17.b) is less than 2.4 for simulations in visible bands, and in [9, 22] for most simulations in the  
559 NIR band, which stresses that DART-Lux usually converges faster in visible bands than in NIR  
560 bands. This is also underlined by the BRF profiles (Figure 13): results are noisier in NIR bands  
561 than in visible bands if the same number of samples per pixel is used.

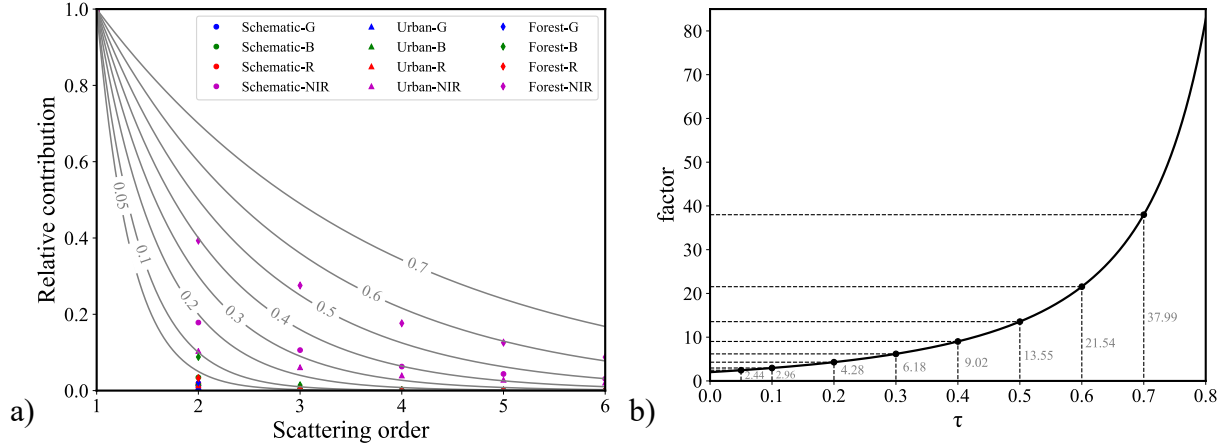

562 Figure 17. Contribution  $g(n)$  of scene radiance for scattering order  $n = 1$  to 6, relative to the  
563 contribution of first order scattering, for the three studied scenes: schematic, urban and forest.  
564 a) Trendlines  $g(n)=\tau^{-(n-1)}$ . b) Factor  $f$  in function of  $\tau$  value (Eq. (23)).

565  
566 The efficiency  $\eta$  of a Monte Carlo method depends on its variance  $\mathbb{V}$  and computation time  $\mathbb{T}$   
567 (Eq. (24)) (Veach, 1997).

$$\eta = \frac{1}{\mathbb{V} \cdot \mathbb{T}} \quad (24)$$

568 Compared to the use of independent paths, the DART-Lux BDPT algorithm appears to be more  
569 efficient despite the correlation of its path samples. The efficiency gains of DART-Lux over  
570 the method with independent path samples is  $\gamma = \left( \frac{\eta_{\text{DART-Lux}}}{\eta_{\text{independent path}}} - 1 \right) = \left( \frac{1}{f} \cdot \frac{N_v^3}{N_v^2 + 2(N_v - 1)} - 1 \right)$ .  
571 1). In visible bands, usually  $N_v = 5$ ,  $f \leq 2.5$ , then  $\gamma > 50\%$ . In NIR bands, usually  $N_v \geq 40$ ,  
572  $f \leq 22$ , then  $\gamma > 70\%$ . Actually,  $\gamma$  is even larger because the variance is usually smaller than  
573 the upper boundary variance.

574

## 575 5.2 Advantages of DART-Lux for simulating images

576 Compared to DART-FT, DART-Lux has great advantages for simulating remote sensing  
577 images and BRF, especially for complex scenes with millions of facets. Table 4 summarizes  
578 the memory demand and computation time of simulations in section 4. For the Järvselja birch  
579 forest, DART-Lux reduces the simulation time by 715 times, and the memory by 142 times.  
580 Four factors explain DART-Lux efficiency. 1) End-to-end simulation: DART-Lux samples the  
581 paths that contribute only to the simulated image whereas DART-FT tracks all possible paths.  
582 2) Efficient path generating strategy: bi-directional random walk and vertex connection ways  
583 can generate a group of paths with less time cost. Despite the potential increase of variance  
584 since path samples can be correlated, the overall efficiency increases (*cf.* section 5.1). 3) Depth-  
585 first strategy: the random walk requires much less memory compared to the breadth-first  
586 strategy of DART-FT whose memory demand greatly increases with scattering order. Although  
587 DART-FT applies an acceleration technique by merging rays that come out of a cell face for  
588 each discrete direction (*cf.* section 4.3), its memory usage is still very high for modelling large-  
589 scale landscapes. 4) Data organisation: for a scene with N instances of a 3D object, DART-Lux  
590 cloning technique stores a unique 3D object and N rotation – scaling matrices whereas DART-  
591 FT stores N 3D objects in the memory for simulating the 3D radiative budget. Therefore,  
592 DART-Lux uses much less memory and time than DART-FT.

593

594 Table 4. Simulation time and memory demand for the three cases of section 4. Cases 1 and 2 are  
595 simulated on a personal computer (Intel Xeon E5-1620 @ 3.5 GHz, 8 cores, 64 Gb memory).  
596 Case 3 is simulated on a server (Intel Xeon E5-2687W @ 3.1 GHz, 40 cores, 560 Gb memory).

Scene	DART-FT		DART-Lux	
	Time (min)	Memory (Gb)	Time (min)	Memory (Gb)

Case 1: Schematic	70.8	1.25	1.38	0.07
Case 2: Urban	571	40.0	10.86	2.60
Case 3: Forest	4962	469.0	6.93	3.30

597

### 598 **5.3 Accuracy of DART-Lux**

599 In theory, the Monte Carlo method is more accurate than the discrete ordinates method, because  
600 it does not need mock-up or modelling simplifications. The DART-FT underestimation of the  
601 hot-spot in Figure 16.f illustrates this point. However, because Monte Carlo methods need many  
602 samples to reach convergence, there is a trade-off between accuracy and number of samples.  
603 Fortunately, DART-Lux accuracy and efficiency is less dependent than DART-FT on the scene  
604 complexity. For example, the forest scene has an average computation time per sample (*i.e.*,  
605  $\frac{\text{Simulation time}}{\text{Number of samples}}$ ) that is only 7 times longer than for the schematic scene, whereas it is 4000  
606 times more complex than the schematic scene in terms of number of facets (Table 5). Table 6  
607 shows the accuracy of DART-Lux forest reflectance for six values of samples/m<sup>2</sup>: difference  
608  $\varepsilon_{\text{mean}}$  of image mean reflectance, and RMSE  $\varepsilon_{\text{pixel}}$  of image pixel reflectance relative to the  
609 reference values computed with a huge number of samples/m<sup>2</sup>. Results stress that DART-Lux  
610 configuration can be optimized according to the application and accuracy requirements. 1)  
611 Convergence is much faster for low reflectance bands than high reflectance bands, which is  
612 consistent with discussion in section 5.1. 2)  $\varepsilon_{\text{mean}}$  and  $\varepsilon_{\text{pixel}}$  decrease with the increase of  
613 samples/m<sup>2</sup>, with a much faster convergence for  $\varepsilon_{\text{mean}}$  than for  $\varepsilon_{\text{pixel}}$ .

614

615 Table 5. Average time cost per sample  $\frac{\text{Simulation time}}{\text{Number of samples}}$  of the schematic and forest scenes in section  
616 4, for an Intel Xeon E5-2687W server (3.1 GHz, 40 cores, 560 Gb memory).

Scene	Nb facet	Nb pixels	Samples/pixel	Time (min)	Time/sample ( $\mu\text{s}$ )
-------	----------	-----------	---------------	------------	-------------------------------

Case 1: Schematic	0.137 10 <sup>6</sup>	65536	400	0.20	<b>0.45</b>
Case 3: Forest	558.2 10 <sup>6</sup>	640000	200	6.93	<b>3.25</b>

617

618

Table 6. Absolute nadir reflectance error  $\epsilon_{\text{mean}}$  and pixel RMSE  $\epsilon_{\text{pixel}}$  of forest scene in the G and

619

NIR bands for six samples/m<sup>2</sup> values; reference images are simulated with 128000 samples/m<sup>2</sup>.

	Samples/m <sup>2</sup>	640	3200	6400	12800	25600	51200
<b>G</b>	$\epsilon_{\text{mean}}$	3.8E-6	9.7E-6	4.0E-7	2.4E-6	1.5E-6	2.1E-6
	$\epsilon_{\text{pixel}}$	0.010	0.005	0.003	0.002	0.002	0.001
<b>NIR</b>	$\epsilon_{\text{mean}}$	3.0E-6	4.1E-5	1.2E-5	4.9E-6	1.3E-5	1.1E-5
	$\epsilon_{\text{pixel}}$	0.075	0.034	0.024	0.018	0.013	0.010

620

## 621 **6 Conclusion and perspectives**

622

The unbiased, rapid and robust DART-Lux is a new Monte Carlo RT method in DART. Its

623

physical modelling relies on a bidirectional path tracing algorithm that efficiently samples a

624

group of paths between the light source and the sensor to estimate radiance measurements. The

625

algorithm is flexible to incorporate multi light sources (*e.g.*, sun and sky) and multi sensors

626

(perspective camera, orthographic camera, BRF camera). It greatly improves the computational

627

efficiency of DART to simulate spectral images and BRF. Its accuracy and efficiency are

628

assessed by standard DART-FT for three landscapes (*i.e.*, schematic scene, urban scene, forest

629

scene). Compared to DART-FT, DART-Lux gives consistent results (relative difference < 1%)

630

while reducing the computation time by up to a factor of 700. In addition, conversely to DART-

631

FT, its accuracy and efficiency depend much less on the landscape complexity.

632

633

A theoretical demonstration gives analytical expressions of the computation time and the largest

634

variance. It appears that DART-Lux algorithm improves efficiency  $\eta$  (*i.e.*, inverse of Variance

635 × Computation time) even if it creates correlated path samples. It also has great advantages and  
636 is much faster for simulating remote sensing images due to end-to-end modelling, efficient path  
637 sampling and depth-first strategy. Finally, a sensitivity study shows that DART-Lux error  
638 decreases with the number of samples, image mean values converges much faster than image  
639 pixel values, and the convergence is faster for low reflectance bands than for high reflectance  
640 bands.

641

642 The high-performance DART-Lux addresses the requirements for simulating large-scale and  
643 complex landscapes and massive remote sensing data, as well as the trends in RT model  
644 development. The Monte Carlo approach is potentially better adapted than discrete ordinates  
645 method for designing and implementing complex physical phenomena such as adjacency  
646 effects and clouds scattering and shadowing. DART-Lux opens new avenues for many remote  
647 sensing applications: design of satellite missions; correction of directional effects; inversion of  
648 remote sensing images; training machine learning models with a large amount of images;  
649 studying the impact of complex 3D architecture, *etc.* DART-Lux modelling development is still  
650 underway to expand DART functionality, including SIF and thermal emission, LiDAR,  
651 atmospheric RT, polarization and 3D radiative budget (Gastellu-Etchegorry et al., 2022;  
652 Regaieg et al., 2022; Yang et al., 2022).

653

#### 654 **Acknowledgement**

655 This work is funded by Région Occitanie Pyrénées-Méditerranée, France and TOSCA program  
656 of CNES. We are grateful to CNRS for funding the PhD of Omar Regaieg through the 80|Prime  
657 program and to Dr I. Georgiev (Saarland University, German) and W. Huang (Walt Disney  
658 Animation Studio, USA) for their advice on the algorithm of bidirectional path tracing. We also



659 thank Toulouse Metropole, and in particular M. Pagès, Head of the Digital Land Modelling  
660 Service, for providing the urban geometric database of the district of Toulouse used in this work.  
661

662 **Appendix A. Definition of the importance function**

663 The importance function  $W_e(r_0, \Omega_0)$  (Nicodemus, 1978), quantifies the sensor response  
 664  $dS(r_0, \Omega_0)$  to the flux  $d\Phi(r_0, \Omega_0)$  incident on the sensor lens at  $r_0$  along direction  $\Omega_0$ .

$$dS(r_0, \Omega_0) = W_e(r_0, \Omega_0)d\Phi(r_0, \Omega_0) \quad (\text{A.1})$$

665 With the usual assumption of constant  $W_e$  for a position  $r_0$  and a direction  $\Omega_0$ , the sensor response  
 666 of pixel  $j$  is:

$$S^{(j)} = \int_{A_0} \int_{\Delta\Omega_0} W_e^{(j)}(r_0, \Omega_0)d\Phi(r_0, \Omega_0) = \int_{A_0} \int_{\Delta\Omega_0} W_e^{(j)}(r_0, \Omega_0) \cdot L(r_1 \rightarrow r_0) \cos \theta_i^{r_0} d\Omega_0 dA(r_0) \quad (\text{A.2})$$

667 DART-Lux importance function  $W_e(r_0, \Omega_0)$  is such that it transfers the sensor response  $S^{(j)}$  to  
 668 radiance measurement  $L^{(j)}$  (*i.e.*, average radiance for pixel area  $A_{\text{img}}^{(j)}$ ), knowing  $L(r_{\text{img}})$  at  $r_{\text{img}}$ :

$$L^{(j)} = \frac{1}{A_{\text{img}}^{(j)}} \int_{A_{\text{img}}^{(j)}} L(r_{\text{img}})dA(r_{\text{img}}) \quad (\text{A.3})$$

669 Below, we give the expression of  $W_e(r_0, \Omega_0)$  for two sensors:

670 Pinhole camera ( $A_0 \ll A_{\text{img}}$ , Figure 3): the optical system does not refract incident rays. Eq.(A.3)

671 gives  $L^{(j)} = \frac{1}{A_{\text{img}}^{(j)}} \cdot \int_{\Delta\Omega_0^{(j)}} L(r_1 \rightarrow r_0) \cdot J_T d\Omega_0$  with transfer function  $J_T = \frac{(f / \cos \theta_i^{r_0})^2}{\cos \theta_i^{r_0}}$  and solid angle

672  $\Delta\Omega_0^{(j)}$  that contains the directions that are mapped to  $A_{\text{img}}^{(j)}$ . Comparing  $L^{(j)}$  to Eq. (A.2) and

673 assuming that  $\int_{\Delta\Omega_0} W_e^{(j)}(r_0, \Omega_0) \cdot L(r_1 \rightarrow r_0) \cdot \cos \theta_i^{r_0} d\Omega_0$  is constant over  $A_0$ , we have:

$$W_e^{(j)}(r_0, \Omega_0) = \begin{cases} \frac{f^2}{A_{\text{img}}^{(j)} \cdot A_0 \cdot (\cos \theta_i^{r_0})^4}, & \Omega_0 \in \Delta\Omega_0^{(j)} \\ 0, & \Omega_0 \notin \Delta\Omega_0^{(j)} \end{cases} \quad (\text{A.4})$$

674 Orthographic camera ( $A_0 \equiv A_{\text{img}}$ , Figure 8): it captures light in very narrow  $\Delta\Omega_0$ . With  $\Omega_d$  the

675 camera orientation,  $S^{(j)} = \int_{A_0} \frac{W_e^{(j)}(r_0, \Omega_0)}{\delta(\Omega_0 - \Omega_d)} \cdot L(r_1 \rightarrow r_0) dA(r_0)$ . Its comparison to Eq. (A.3) gives:

$$W_e^{(j)}(r_0, \Omega_0) = \frac{\delta(\Omega_0 - \Omega_d)}{A_{\text{img}}^{(j)}} \quad (\text{A.5})$$

676 **Appendix B. Importance transport equation (backward light transport)**

677 Christensen et al. (1993) proved that the backward and forward light transport are symmetric if  
678 the BSDF reciprocity is verified. Then, the importance function  $W_e$  can be treated equivalently  
679 as an exit quantity as the emitted radiance  $L_e$ . The importance function  $W^{(j)}(r \rightarrow r')$  along  
680 direction  $r \rightarrow r'$  quantifies the contribution of the exit radiance at  $r'$  to the radiance  
681 measurement at pixel  $j$ . Let a virtual ray carrying  $W^{(j)}(r \rightarrow r')$  that starts from  $r$ , and is  
682 virtually scattered to  $r''$  after being intercepted at  $r'$ . The adjoint formulation of Eq. (3) is:

$$W^{(j)}(r' \rightarrow r'') = W_e^{(j)}(r' \rightarrow r'') + \int_A W^{(j)}(r \rightarrow r') \cdot f(r \rightarrow r' \rightarrow r'') \cdot G(r \leftrightarrow r') dA(r) \quad (\text{B.1})$$

683 Eq. (3) and Eq. (B.1) are symmetric if there is BSDF reciprocity, *i.e.*,  $f(r \rightarrow r' \rightarrow r'') =$   
684  $f(r'' \rightarrow r' \rightarrow r)$ .

685

686

687 **Appendix C. MIS weight evaluation**

688 Direct evaluation of the MIS weight is very computationally expensive, which reduces the  
 689 efficiency of the bidirectional path tracing algorithm. DART-Lux uses an efficient method to  
 690 evaluate it incrementally along the random walk.

691

692 The power heuristic MIS weight is:

$$w_{s,t}(\bar{r}_{s,t}) = \frac{\left(p(\bar{r}_{s,t})\right)^2}{\sum_{s'=0}^{n+1} \left(p(\bar{r}_{s',t'})\right)^2} \quad (\text{C.1})$$

693 where  $s + t = s' + t' = n + 1$ . The virtual path  $\bar{r}_{s',t'}$  with  $(s', t') \neq (s, t)$  has the same  
 694 vertices as the sampled path  $\bar{r}_{s,t}$ , but is generated with another sampling way (Figure 6). The  
 695 term “virtual path” emphasizes that the path is only used to evaluate the MIS weight  $w_{s,t}(\bar{r}_{s,t})$ .

696

697 The division of Eq. (C.1) by  $\left(p(\bar{r}_{s,t})\right)^2$  gives:

$$w_{s,t}(\bar{r}_{s,t}) = \frac{1}{w_{s-1}^{\text{light}} + 1 + w_{t-1}^{\text{sensor}}} \quad (\text{C.2})$$

698 with

$$w_{s-1}^{\text{light}} = \sum_{s'=0}^{s-1} \left(\frac{p(\bar{r}_{s',t'})}{p(\bar{r}_{s,t})}\right)^2 \quad \text{and} \quad w_{t-1}^{\text{sensor}} = \sum_{t'=0}^{t-1} \left(\frac{p(\bar{r}_{s',t'})}{p(\bar{r}_{s,t})}\right)^2 \quad (\text{C.3})$$

699 The terms  $\vec{p}(p_k) \equiv p(p_k | p_{k-1}, p_{k-2})$ ,  $\tilde{p}(p_k) \equiv p(p_k | p_{k+1}, p_{k+2})$  and  $\vec{p}(q_k) \equiv$   
 700  $p(q_k | q_{k+1}, q_{k+2})$ ,  $\tilde{p}(q_k) \equiv p(q_k | q_{k-1}, q_{k-2})$  are used to simplify the expressions of  $p(\bar{r}_{s,t})$

701 and  $p(\bar{r}_{s',t'})$ :

$$p(\bar{r}_{s,t}) = p(\bar{p}_s) \cdot p(\bar{p}_t) = \prod_{k=0}^{s-1} \vec{p}(p_k) \cdot \prod_{k=0}^{t-1} \tilde{p}(q_k) \quad (\text{C.4})$$

$$p(\bar{r}_{s',t'}) = \begin{cases} \prod_{k=0}^{s'-1} \vec{p}(p_k) \cdot \prod_{k=s'}^{s-1} \tilde{p}(p_k) \cdot \prod_{k=0}^{t-1} \tilde{p}(q_k), & s' < s \\ \prod_{k=0}^{s-1} \vec{p}(p_k) \cdot \prod_{k=t'}^{t-1} \vec{p}(q_k) \cdot \prod_{k=0}^{t'-1} \tilde{p}(q_k), & s' > s \end{cases}$$

702 Using Eq. (C.4), Eq. (C.3) can be expanded as

$$w_{s-1}^{\text{light}} = \sum_{s'=0}^{s-1} \left( \frac{\prod_{k=0}^{s'-1} \vec{p}(p_k) \cdot \prod_{k=s'}^{s-1} \tilde{p}(p_k) \cdot \prod_{k=0}^{t-1} \tilde{p}(q_k)}{\prod_{k=0}^{s-1} \vec{p}(p_k) \cdot \prod_{k=0}^{t-1} \tilde{p}(q_k)} \right)^2 = \sum_{s'=0}^{s-1} \left( \prod_{k=s'}^{s-1} \frac{\tilde{p}(p_k)}{\vec{p}(p_k)} \right)^2 \quad (\text{C.5})$$

$$w_{t-1}^{\text{sensor}} = \sum_{t'=0}^{t-1} \left( \frac{\prod_{k=0}^{s-1} \vec{p}(p_k) \cdot \prod_{k=t'}^{t-1} \vec{p}(q_k) \cdot \prod_{k=0}^{t'-1} \tilde{p}(q_k)}{\prod_{k=0}^{s-1} \vec{p}(p_k) \cdot \prod_{k=0}^{t-1} \tilde{p}(q_k)} \right)^2 = \sum_{t'=0}^{t-1} \left( \prod_{k=t'}^{t-1} \frac{\vec{p}(q_k)}{\tilde{p}(q_k)} \right)^2$$

703 Both  $w_{s-1}^{\text{light}}$  and  $w_{t-1}^{\text{sensor}}$  can be iteratively evaluated. After mathematical inductions, Eq. (C.6)

704 can be incrementally evaluated along the random walk. Then, the MIS weight (Eq. (C.2)) of

705 any path sample is fast computed based on  $w_k^{\text{light}}$  and  $w_k^{\text{sensor}}$ .

$$w_k^{\text{light}} = [\tilde{p}(p_k)]^2 \left( \frac{1}{[\vec{p}(p_k)]^2} + \frac{w_{k-1}^{\text{light}}}{[\tilde{p}(p_k)]^2} \right)$$

$$w_k^{\text{sensor}} = [\vec{p}(q_k)]^2 \left( \frac{1}{[\tilde{p}(q_k)]^2} + \frac{w_{k-1}^{\text{sensor}}}{[\vec{p}(q_k)]^2} \right) \quad (\text{C.6})$$

706

707

708 **Appendix D. Upper boundary of estimate variance of  $C_{\mathcal{D}_n}$**

709 The variance of estimate of scattering order contribution  $C_{\mathcal{D}_n}$  can increase if path samples  $\bar{r}_{s,t}$

710 ( $\bar{r}_{s,t} \in \mathcal{D}_n, s+t=n+1$ ) are not all independent. The MIS estimator for  $C_{\mathcal{D}_n}$  and its variance are

$$F_{\mathcal{D}_n} = \sum_{s=0}^{n+1} w_{s,t}(\bar{r}_{s,t}) \cdot \frac{f^{(j)}(\bar{r}_{s,t})}{p(\bar{r}_{s,t})} = \sum_{s=0}^{n+1} F_{s,t} \quad (s+t=n+1) \quad (\text{D.1})$$

$$\mathbb{V}(F_{\mathcal{D}_n}) = \sum_{s=0}^{n+1} \sum_{s'=0}^{n+1} \text{Cov}(F_{s,t}, F_{s',t'}) = \sum_{s=0}^{n+1} \mathbb{V}(F_{s,t}) + \sum_{s=0}^{n+1} \sum_{s'=0, s' \neq s}^{n+1} \text{Cov}(F_{s,t}, F_{s',t'}) \quad (\text{D.2})$$

711 With independent path samples,  $|\text{Cov}(F_{s,t}, F_{s',t'})| = 0 \quad \forall s' \neq s$ , then  $\mathbb{V}(F_N) = \sum_{s=0}^{n+1} \mathbb{V}(F_{s,t}) = \delta_{\mathcal{D}_n}^2$ .

712 When  $|\text{Cov}(F_{s,t}, F_{s',t'})| > 0$  the overall variance can increase. By resampling vertices on light

713 source or sensor (*i.e.*, no re-use of already sampled vertex), the ‘‘connect to light’’ and ‘‘connect

714 to sensor’’ methods (Figure 5) reduce path correlation. For path sample  $\bar{r}_{s,t}$  of length  $n$ :

715  $\text{Cov}(\bar{r}_{0,n+1}, \bar{r}_{n+1,0}) = \text{Cov}(\bar{r}_{1,n}, \bar{r}_{n,1}) = \text{Cov}(\bar{r}_{0,n+1}, \bar{r}_{n,1}) = \text{Cov}(\bar{r}_{1,n}, \bar{r}_{n+1,0}) = 0$  and  $\mathbb{V}(F_{\mathcal{D}_1}) = \delta_{\mathcal{D}_1}^2$ .

716 If  $n > 1$ , the upper boundary of  $\mathbb{V}(F_{\mathcal{D}_n})$  is computed with the Cauchy-Schwarz inequality

717  $\text{Cov}(X, Y) \leq \sqrt{\mathbb{V}(X) \cdot \mathbb{V}(Y)}$  and inequality  $\sqrt{\mathbb{V}(X) \cdot \mathbb{V}(Y)} \leq \frac{\mathbb{V}(X) + \mathbb{V}(Y)}{2}$ .

$$\begin{aligned} 718 \quad \mathbb{V}(F_{\mathcal{D}_n}) &\leq \sum_{s=0}^{n+1} \sum_{s'=0}^{n+1} \frac{\mathbb{V}(F_{s,t}) + \mathbb{V}(F_{s',t'})}{2} - 2 \left( \mathbb{V}(F_{0,n+1}) + \mathbb{V}(F_{1,n}) + \mathbb{V}(F_{n+1,0}) + \mathbb{V}(F_{n,1}) \right) \\ 719 \quad &= (n+2)\delta_{\mathcal{D}_n}^2 - 2 \left( \mathbb{V}(F_{0,n+1}) + \mathbb{V}(F_{1,n}) + \mathbb{V}(F_{n+1,0}) + \mathbb{V}(F_{n,1}) \right) \end{aligned}$$

$$\text{Hence:} \quad \begin{cases} \mathbb{V}(F_{\mathcal{D}_n}) = \delta_{\mathcal{D}_n}^2, & \text{if } n = 1 \\ \mathbb{V}(F_{\mathcal{D}_n}) \leq 2\delta_{\mathcal{D}_n}^2, & \text{if } n = 2 \\ \mathbb{V}(F_{\mathcal{D}_n}) \leq (n+2)\delta_{\mathcal{D}_n}^2, & \text{if } n > 2 \end{cases} \quad (\text{D.3})$$

720 Although the variance of the estimator  $F_{\mathcal{D}_n}$  can increase due to correlation, it is still unbiased:

$$\begin{aligned} 721 \quad \mathbb{E}(F_{\mathcal{D}_n}) &= \sum_{s=0}^{n+1} \mathbb{E}(F_{s,t}) \quad (s+t=n+1) = \sum_{s=0}^{n+1} \int_{\mathcal{D}_n} w_{s,t}(\bar{r}_n) \cdot \frac{f(\bar{r}_n)}{p(\bar{r}_n)} \cdot p(\bar{r}_n) d\mu(\bar{r}_n) \quad (s+t=n+1) \\ 722 \quad &= \int_{\mathcal{D}_n} \left( \sum_{s=0}^{n+1} w_{s,t}(\bar{r}_n) \right) \cdot f(\bar{r}_n) d\mu(\bar{r}_n) \quad (s+t=n+1) = \int_{\mathcal{D}_n} f(\bar{r}_n) d\mu(\bar{r}_n) \end{aligned}$$

723 where  $p(\bar{r}_n)$  is a marginal PDF if the path samples are correlated.

725 **Appendix E. Upper boundary of variance for radiance measurement**

726 The methodology in appendix D can be extended to evaluate the upper boundary variance of  
 727 MIS estimator for radiance measurement (Eq. (15)). Since in most optical Earth observation  
 728 missions, the sensor does not see the light source (*e.g.*, sun), the contribution  $C_{\mathcal{D}_1}$  is zero, and  
 729 the correlation between path samples does not affect the variance of estimate for  $C_{\mathcal{D}_1}$  (Eq. (D.3)).  
 730 Therefore, the following discussion focuses on the impact of path sample correlation on the  
 731 contributions for scattering order larger or equal to one. Then, the MIS estimator becomes:

$$F_{\text{MIS}} = \sum_{n=2}^{\infty} F_{\mathcal{D}_n} \quad (\text{E.1})$$

732 Eq. (E.1) is unbiased (*cf.* appendix D) even if path samples are correlated. Its variance is:

$$\mathbb{V}(F_{\text{MIS}}) = \sum_{n_1=2}^{\infty} \sum_{n_2=2}^{\infty} \text{Cov}(F_{\mathcal{D}_{n_1}}, F_{\mathcal{D}_{n_2}}) \quad (\text{E.2})$$

733 (Kallel, 2018) shows that the contribution  $C_{\mathcal{D}_n}$  decreases exponentially with the scattering order.

734 We can suppose  $C_{\mathcal{D}_{n+1}} \approx \tau \cdot C_{\mathcal{D}_n}$ ,  $\tau$  is a constant,  $0 \leq \tau \leq 1$ . It is more or less true in most RT  
 735 modelling for remote sensing data (Figure 17.a). It leads to:  $\mathbb{V}(F_{\mathcal{D}_{n+1}}) \approx \tau^2 \cdot \mathbb{V}(F_{\mathcal{D}_n})$ .

736

737 If all the path samples are independent, the variance  $\mathbb{V}(F_{\text{MIS}})$  is the sum of  $\delta_{\mathcal{D}_n}^2$

$$\mathbb{V}(F_{\text{MIS}}) = \sum_{n=2}^{\infty} \delta_{\mathcal{D}_n}^2 = \sum_{n=2}^{\infty} \tau^{2(n-2)} \cdot \delta_{\mathcal{D}_2}^2 = \frac{\delta_{\mathcal{D}_2}^2}{1 - \tau^2} = \delta_0^2 \quad (\text{E.3})$$

738 If path samples are not all independent, the Cauchy-Schwarz inequality and Eq. (D.3) lead to:

$$\begin{aligned}
739 \quad \mathbb{V}(F_{\text{MIS}}) &= \sum_{n_1=2}^{\infty} \sum_{n_2=2}^{\infty} \text{Cov}(F_{\mathcal{D}_{n_1}}, F_{\mathcal{D}_{n_2}}) \leq \sum_{n_1=2}^{\infty} \sum_{n_2=2}^{\infty} \sqrt{\mathbb{V}(F_{\mathcal{D}_{n_1}}) \cdot \mathbb{V}(F_{\mathcal{D}_{n_2}})} \\
740 \quad &= \mathbb{V}(F_{\mathcal{D}_2}) + 2\sqrt{\mathbb{V}(F_{\mathcal{D}_2})} \sum_{n=3}^{\infty} \sqrt{\mathbb{V}(F_{\mathcal{D}_n})} + \sum_{n_1=3}^{\infty} \sqrt{\mathbb{V}(F_{\mathcal{D}_{n_1}})} \sum_{n_2=3}^{\infty} \sqrt{\mathbb{V}(F_{\mathcal{D}_{n_2}})} \\
741 \quad &\leq 2\delta_{\mathcal{D}_2}^2 + 2\sqrt{2}\delta_{\mathcal{D}_2} \left( \sum_{n=3}^{\infty} \sqrt{n+2} \delta_{\mathcal{D}_n} \right) + \sum_{n_1=3}^{\infty} \sqrt{n_1+2} \delta_{\mathcal{D}_{n_1}} \sum_{n_2=3}^{\infty} \sqrt{n_2+2} \delta_{\mathcal{D}_{n_2}} \\
742 \quad &= \delta_{\mathcal{D}_2}^2 \left( 2 + 2\sqrt{2} \cdot \sum_{n=3}^{\infty} \sqrt{(n+2)} \cdot \tau^{n-2} + \sum_{n_1=3}^{\infty} \sum_{n_2=3}^{\infty} \sqrt{(n_1+2)(n_2+2)} \cdot \tau^{n_1-2} \cdot \tau^{n_2-2} \right)
\end{aligned}$$

743 Because  $\sqrt{(n_1+2)(n_2+2)} \leq \frac{(n_1+2)+(n_2+2)}{2}$ ,  $\sqrt{(n+2)} \cdot 1 \leq \frac{(n+2)+1}{2}$  when  $n > 0$  and

744  $\sum_{n=3}^{\infty} (n+i) \cdot \tau^{n-2} = \frac{(3+i)\tau - (2+i)\tau^2}{(1-\tau)^2}$  ( $i \in \mathbb{N}$ ), we have:

$$\begin{aligned}
\mathbb{V}(F_{\text{MIS}}) &\leq \delta_{\mathcal{D}_2}^2 \left( \frac{2+(6\sqrt{2}-6)\tau+(11-11\sqrt{2})\tau^2+(5\sqrt{2}-6)\tau^3}{(1-\tau)^3} \right) = \left( \frac{2+\tau\left(\frac{\sqrt{2}}{2}-\tau\right)(3-\tau)}{(1-\tau)^3} + \right. \\
&\quad \left. \frac{\left(\frac{9}{\sqrt{2}}-6\right)\tau+(14-\frac{21}{\sqrt{2}})\tau^2+(5\sqrt{2}-7)\tau^3}{(1-\tau)^3} \right) \approx \delta_{\mathcal{D}_2}^2 \cdot \left( \frac{2+\tau\left(\frac{\sqrt{2}}{2}-\tau\right)(3-\tau)}{(1-\tau)^3} \right) = \delta_0^{*2}
\end{aligned} \tag{E.4}$$

745 The term  $\left(\frac{9}{\sqrt{2}}-6\right)\tau + \left(14-\frac{21}{\sqrt{2}}\right)\tau^2 + (5\sqrt{2}-7)\tau^3$  is omitted since it is less than  $0.04 \ll 1$  if

746  $\tau \in [0,1]$ . Hence, the variance will increase maximally by a factor of

$$\frac{\delta_0^{*2}}{\delta_0^2} = \frac{(1+\tau) \cdot \left( 2 + \tau \left( \frac{\sqrt{2}}{2} - \tau \right) (3 - \tau) \right)}{(1-\tau)^2} \tag{E.5}$$

747 In the short waves, a sensor does not usually see the light source, conversely to the long waves

748 where the observed landscape is a light source, which implies that the contribution  $C_{\mathcal{D}_1}$  to the

749 measured radiance is usually large. Then, the same method as above shows that the variance

750 maximally increases by the factor  $\frac{\delta_0^{*2}}{\delta_0^2} = \frac{(1+\tau) \cdot (1+\tau^2 \cdot (1-\tau^2) \cdot (2-\tau))}{(1-\tau)^2}$ .



751 **Reference**

752

753 Berk, A., Anderson, G.P., Acharya, P.K., Shettle, E.P., 2008. MODTRAN5. 2.0. 0 user's  
754 manual. Spectr. Sci. Inc., Burlingt. MA, Air Force Res. Lab. Hanscom MA.

755 Berk, A., Bernstein, L.S., Robertson, D.C., 1987. MODTRAN: A moderate resolution model  
756 for LOWTRAN. SPECTRAL SCIENCES INC BURLINGTON MA.

757 Christensen, P.H., Salesin, D.H., DeRose, T.D., Aupperle, L., 1993. A continuous adjoint  
758 formulation for radiance transport, in: Proceedings of the Fourth Eurographics Workshop  
759 on Rendering. Citeseer, pp. 95–104.

760 Gascon, F., Gastellu-Etchegorry, J.-P., Lefèvre, M.-J., 2001. Radiative transfer model for  
761 simulating high-resolution satellite images. IEEE Trans. Geosci. Remote Sens. 39, 1922–  
762 1926.

763 Gastellu-Etchegorry, J.-P., 2008. 3D modeling of satellite spectral images, radiation budget and  
764 energy budget of urban landscapes. Meteorol. Atmos. Phys. 102, 187.

765 Gastellu-Etchegorry, J.-P., Demarez, V., Pinel, V., Zagolski, F., 1996. Modeling radiative  
766 transfer in heterogeneous 3-D vegetation canopies. Remote Sens. Environ. 58, 131–156.

767 Gastellu-Etchegorry, J.-P., Lauret, N., Yin, T., Landier, L., Kallel, A., Malenovský, Z., Al Bitar,  
768 A., Aval, J., Benhmida, S., Qi, J., 2017. DART: recent advances in remote sensing data  
769 modeling with atmosphere, polarization, and chlorophyll fluorescence. IEEE J. Sel. Top.  
770 Appl. Earth Obs. Remote Sens. 10, 2640–2649.

771 Gastellu-Etchegorry, J.-P., Yin, T., Lauret, N., Cajgfinger, T., Gregoire, T., Grau, E., Feret, J.-  
772 B., Lopes, M., Guilleux, J., Dedieu, G., 2015. Discrete anisotropic radiative transfer  
773 (DART 5) for modeling airborne and satellite spectroradiometer and LIDAR acquisitions  
774 of natural and urban landscapes. Remote Sens. 7, 1667–1701.

775 Goel, N.S., 1988. Models of vegetation canopy reflectance and their use in estimation of

776 biophysical parameters from reflectance data. *Remote Sens. Rev.* 4, 1–212.

777 Goel, N.S., Rozehnal, I., Thompson, R.L., 1991. A computer graphics based model for  
778 scattering from objects of arbitrary shapes in the optical region. *Remote Sens. Environ.* 36,  
779 73–104.

780 Goodenough, A.A., Brown, S.D., 2017. DIRSIG5: next-generation remote sensing data and  
781 image simulation framework. *IEEE J. Sel. Top. Appl. Earth Obs. Remote Sens.* 10, 4818–  
782 4833.

783 Govaerts, Y.M., 1996. A model of light scattering in three-dimensional plant canopies: a Monte  
784 Carlo ray tracing approach. Citeseer.

785 Grau, E., Gastellu-Etchegorry, J.-P., 2013. Radiative transfer modeling in the Earth–  
786 Atmosphere system with DART model. *Remote Sens. Environ.* 139, 149–170.

787 Guillevic, P., Gastellu-Etchegorry, J.P., Demarty, J., Prévot, L., 2003. Thermal infrared  
788 radiative transfer within three-dimensional vegetation covers. *J. Geophys. Res. Atmos.*  
789 108.

790 Hosek, L., Wilkie, A., 2012. An analytic model for full spectral sky-dome radiance. *ACM Trans.*  
791 *Graph.* 31, 1–9.

792 Huang, H., Qin, W., Liu, Q., 2013. RAPID: A Radiosity Applicable to Porous Individual  
793 Objects for directional reflectance over complex vegetated scenes. *Remote Sens. Environ.*  
794 132, 221–237.

795 Jakob, W., 2010. Mitsuba renderer.

796 Janoutová, R., Homolová, L., Malenovský, Z., Hanuš, J., Lauret, N., Gastellu-Etchegorry, J.-  
797 P., 2019. Influence of 3D spruce tree representation on accuracy of airborne and satellite  
798 forest reflectance simulated in DART. *Forests* 10, 292.

799 Kahn, H., Marshall, A.W., 1953. Methods of reducing sample size in Monte Carlo computations.  
800 *J. Oper. Res. Soc. Am.* 1, 263–278.

801 Kajiya, J.T., 1986. The rendering equation, in: Proceedings of the 13th Annual Conference on  
802 Computer Graphics and Interactive Techniques. pp. 143–150.

803 Kallel, A., 2018. Leaf polarized BRDF simulation based on Monte Carlo 3-D vector RT  
804 modeling. *J. Quant. Spectrosc. Radiat. Transf.* 221, 202–224.

805 Kimes, D.S., Kirchner, J.A., 1982. Radiative transfer model for heterogeneous 3-D scenes.  
806 *Appl. Opt.* 21, 4119–4129.

807 Kraska, T.A., 1996. DIRSIG: Digital Imaging and Remote Sensing Image Generation Model:  
808 Infrared Airborne Validation and Input Parameter Analysis. AIR FORCE INST OF TECH  
809 WRIGHT-PATTERSON AFB OH.

810 Lafortune, E.P., Willems, Y.D., 1993. Bi-directional path tracing.

811 Lewis, P., 1999. Three-dimensional plant modelling for remote sensing simulation studies  
812 using the Botanical Plant Modelling System. *Agronomie* 19, 185–210.

813 Myneni, R.B., Asrar, G., Gerstl, S.A.W., 1990. Radiative transfer in three dimensional leaf  
814 canopies. *Transp. Theory Stat. Phys.* 19, 205–250.

815 Myneni, R.B., Ross, J., Asrar, G., 1989. A review on the theory of photon transport in leaf  
816 canopies. *Agric. For. Meteorol.* 45, 1–153.

817 Nicodemus, F.E., 1978. Self-study manual on optical radiation measurements: Part I–Concepts,  
818 Chap. 4 and 5 p97. Nar. Bur. Stand (US). Tech. Note 910-2.

819 Nimier-David, M., Vicini, D., Zeltner, T., Jakob, W., 2019. Mitsuba 2: A retargetable forward  
820 and inverse renderer. *ACM Trans. Graph.* 38, 1–17.

821 North, P.R.J., 1996. Three-dimensional forest light interaction model using a Monte Carlo  
822 method. *IEEE Trans. Geosci. Remote Sens.* 34, 946–956.

823 Pharr, M., Jakob, W., Humphreys, G., 2016. Physically based rendering: From theory to  
824 implementation. Morgan Kaufmann.

825 Preetham, A.J., Shirley, P., Smits, B., 1999. A practical analytic model for daylight, in:

826 Proceedings of the 26th Annual Conference on Computer Graphics and Interactive  
827 Techniques. pp. 91–100.

828 Qi, J., Xie, D., Yin, T., Yan, G., Gastellu-Etchegorry, J.-P., Li, L., Zhang, W., Mu, X., Norford,  
829 L.K., 2019a. LESS: Large-Scale remote sensing data and image simulation framework  
830 over heterogeneous 3D scenes. *Remote Sens. Environ.* 221, 695–706.

831 Qi, J., Yin, T., Xie, D., Gastellu-Etchegorry, J.-P., 2019b. Hybrid Scene Structuring for  
832 Accelerating 3D Radiative Transfer Simulations. *Remote Sens.* 11, 2637.

833 Qin, W., Gerstl, S.A.W., 2000. 3-D scene modeling of semidesert vegetation cover and its  
834 radiation regime. *Remote Sens. Environ.* 74, 145–162.

835 Richtsmeier, S.C., Berk, A., Bernstein, L.S., Adler-Golden, S.M., 2001. A 3-Dimensional  
836 radiative-transfer hyperspectral image simulator for algorithm validation, in: *International*  
837 *Symposium on Spectral Sensing Research.* p. 15.

838 Sobrino, J.A., Mattar, C., Gastellu-Etchegorry, J.-P., Jiménez-Muñoz, J.C., Grau, E., 2011.  
839 Evaluation of the DART 3D model in the thermal domain using satellite/airborne imagery  
840 and ground-based measurements. *Int. J. Remote Sens.* 32, 7453–7477.

841 Thompson, R.L., Goel, N.S., 1998. Two models for rapidly calculating bidirectional reflectance  
842 of complex vegetation scenes: Photon spread (PS) model and statistical photon spread  
843 (SPS) model. *Remote Sens. Rev.* 16, 157–207.

844 Veach, E., 1997. Robust Monte Carlo methods for light transport simulation. Stanford  
845 University PhD thesis.

846 Veach, E., Guibas, L., 1995a. Bidirectional estimators for light transport, in: *Photorealistic*  
847 *Rendering Techniques.* Springer, pp. 145–167.

848 Veach, E., Guibas, L.J., 1995b. Optimally combining sampling techniques for Monte Carlo  
849 rendering, in: *Proceedings of the 22nd Annual Conference on Computer Graphics and*  
850 *Interactive Techniques.* pp. 419–428.

851 Wald, I., Woop, S., Benthin, C., Johnson, G.S., Ernst, M., 2014. Embree: a kernel framework  
852 for efficient CPU ray tracing. *ACM Trans. Graph.* 33, 1–8.

853 Wang, Y., Gastellu-Etchegorry, J.-P., 2021. Accurate and fast simulation of remote sensing  
854 images at top of atmosphere with DART-Lux. *Remote Sens. Environ.* 256, 112311.

855 Wang, Y., Gastellu-Etchegorry, J.-P., 2020. DART: Improvement of thermal infrared radiative  
856 transfer modelling for simulating top of atmosphere radiance. *Remote Sens. Environ.* 251,  
857 112082.

858 Weinzierl, S., 2000. Introduction to monte carlo methods. *arXiv Prepr. hep-ph/0006269*.

859 Widlowski, J.-L., Lavergne, T., Pinty, B., Verstraete, M., Gobron, N., 2006. Rayspread: A  
860 virtual laboratory for rapid BRF simulations over 3-D plant canopies, in: *Computational*  
861 *Methods in Transport*. Springer, pp. 211–231.

862 Widlowski, J.-L., Mio, C., Disney, M., Adams, J., Andreadakis, I., Atzberger, C., Brennan, J.,  
863 Busetto, L., Chelle, M., Ceccherini, G., 2015. The fourth phase of the radiative transfer  
864 model intercomparison (RAMI) exercise: Actual canopy scenarios and conformity testing.  
865 *Remote Sens. Environ.* 169, 418–437.

866 Widlowski, J., Pinty, B., Lopatka, M., Atzberger, C., Buzica, D., Chelle, M., Disney, M.,  
867 Gastellu-Etchegorry, J., Gerboles, M., Gobron, N., 2013. The fourth radiation transfer  
868 model intercomparison (RAMI-IV): Proficiency testing of canopy reflectance models with  
869 ISO-13528. *J. Geophys. Res. Atmos.* 118, 6869–6890.

870 Widlowski, J., Taberner, M., Pinty, B., Bruniquel-Pinel, V., Disney, M., Fernandes, R.,  
871 Gastellu-Etchegorry, J., Gobron, N., Kuusk, A., Lavergne, T., 2007. Third Radiation  
872 Transfer Model Intercomparison (RAMI) exercise: Documenting progress in canopy  
873 reflectance models. *J. Geophys. Res. Atmos.* 112.

874 Woo, A., Pearce, A., Ouellette, M., 1996. It's really not a rendering bug, you see. *IEEE Comput.*  
875 *Graph. Appl.* 16, 21–25.

876 Woop, S., Benthin, C., Wald, I., 2013. Watertight ray/triangle intersection. *J. Comput. Graph.*  
877 *Tech.* 2, 65–82.

878 Yin, T., Lauret, N., Gastellu-Etchegorry, J.-P., 2016. Simulation of satellite, airborne and  
879 terrestrial LiDAR with DART (II): ALS and TLS multi-pulse acquisitions, photon  
880 counting, and solar noise. *Remote Sens. Environ.* 184, 454–468.

881