

Bypassing pre-boot authentication passwords

by instrumenting the BIOS keyboard buffer

(practical low level attacks against x86 pre-boot authentication software)

Jonathan Brossard - iViZ Technosolutions Research Team

jonathan@ivizindia.com
endrazine@gmail.com

DEFCON 16





Who am I ?



Scope of this presentation



- We present a new class of vulnerabilities,
- Affecting multiple pre-boot authentication software under x86 and x64 architectures,
- Exploitable without physical access.

Limitations : we will focus on password based authentication solely.

Contents



- (Technically) defining pre-boot authentication
- Password leakage under Windows
- Password leakage under *nix
- Rebooting in spite of a pre-boot authentication
- Examples of vulnerable software
- Mitigating those vulnerabilities

I - (Technically) defining pre-boot authentication



- Boot sequence overview
- Taxonomy of pre-boot authentication software
- BIOS API for user inputs
- BIOS internals for keyboard management
- BIOS keyboard buffer Remanence...
- Verifying this bug exists “in real life”
- Password chaining

I-1) Boot sequence overview

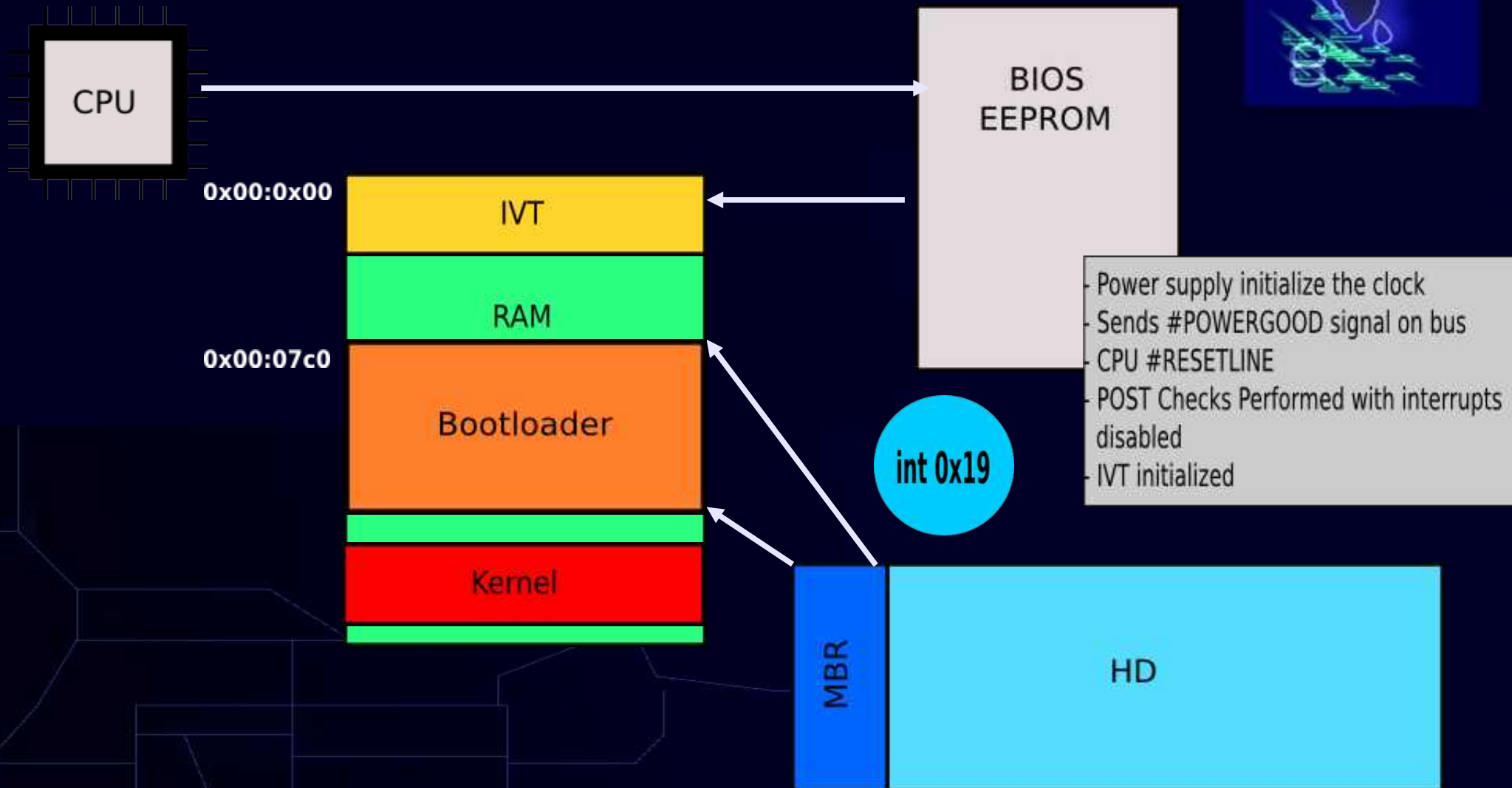

I-2) Taxonomy of pre-boot authentication softwares



- Bios Passwords
- Bootloader Passwords (Vista's Bitlocker, Grub or Lilo, and most others pre-boot authentication software : Truecrypt, Diskcryptor...)
- Early kernel stage passwords – typically before decompression (eg: suspend2 hibernation patch for GNU/Linux)

I-3) BIOS API for user inputs (1/2)



- Interruption 0x16 invoked via functions :
- **ah=0x00** , “Get keystroke” : returns the keystroke scancode in AH and its ASCII code in AL.
- **ah=0x01** , “Check for keystroke” : idem, but the Zero Flag is set if no keystroke is available in the Bios keyboard buffer.

I-3) BIOS API for user inputs (2/2)



- eg : lilo password reading routine :

```
236 drkbd: mov  ah,#1      ; is a key pressed ?
237      int  0x16
238      jz   comcom      ; no -> done
239      xor  ah,ah       ; get the key
240      int  0x16
241      loop drkbd
```

I-4) BIOS internals for keyboard management

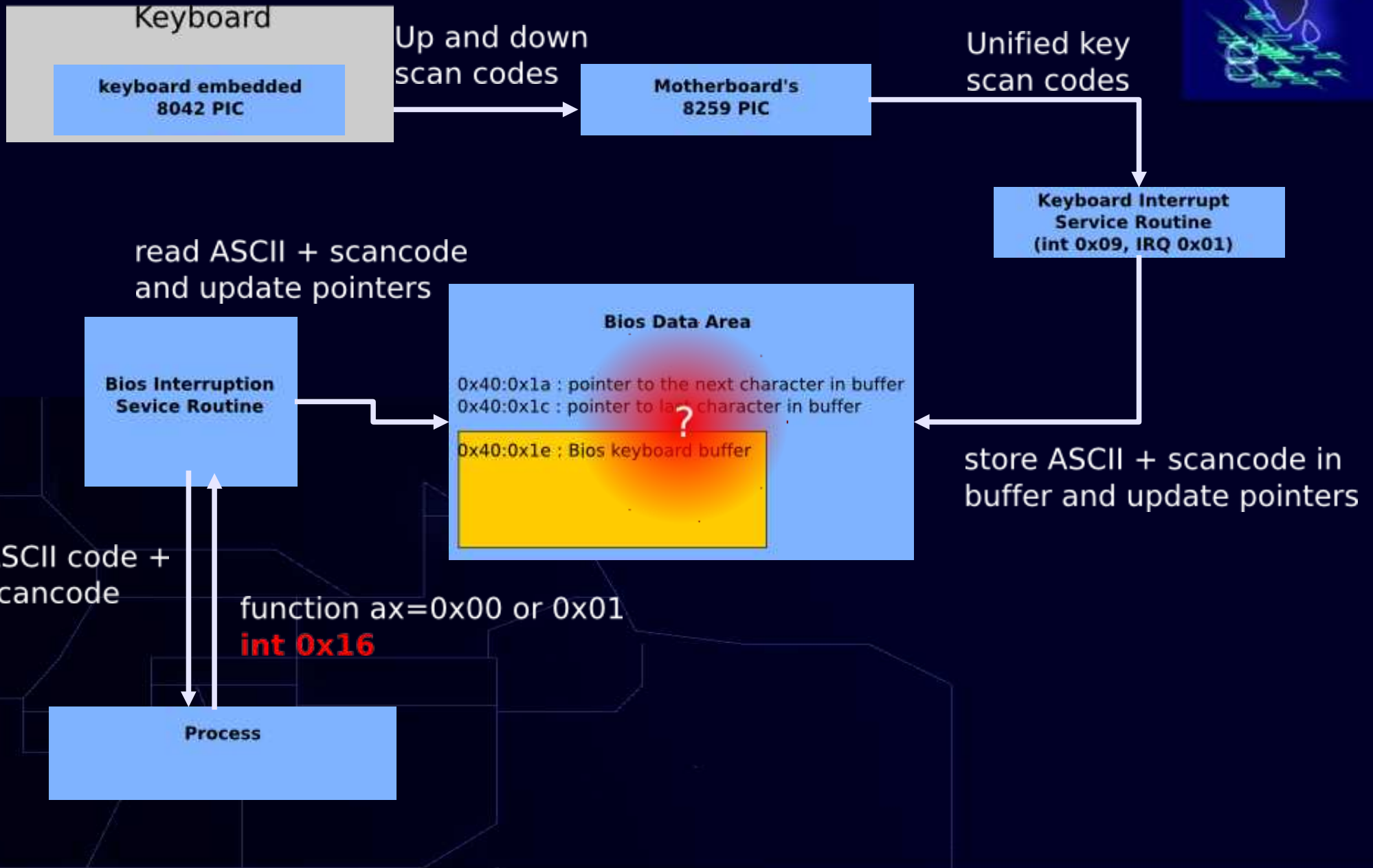

I-5) BIOS keyboard buffer Remanance... (1/3)



- Filling the BIOS keyboard buffer (with the keyboard) :

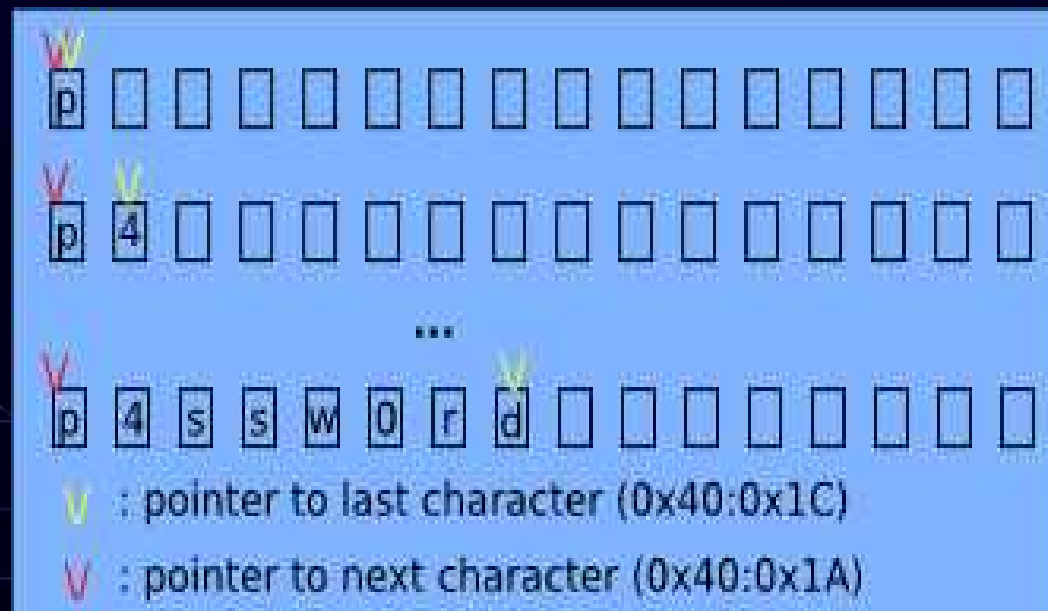

I-5) BIOS keyboard buffer Remanence... (2/3)



- Reading the BIOS keyboard buffer (using int 0x16, ah=0x00 or 0x01) :

Before read :

p 4 s s w o r d

After read :

p 4 s s w o r d

Y : pointer to last character (0x40:0x1C)
V : pointer to next character (0x40:0x1A)

I-5) BIOS keyboard buffer Remanence... (3/3)

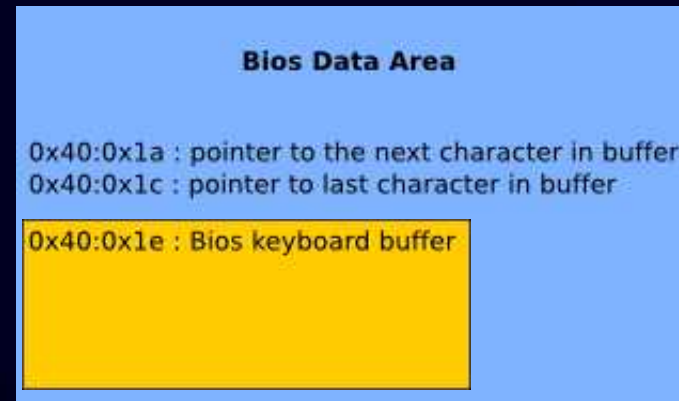

Who is supposed to clear the keyboard buffer ?

I-6) Verifying this bug exists “in real life” (1/2) :



- We want to check the authentication routines in the BIOS themselves (aka: BIOS Passwords)
- We will write a small USB-bootable OS in 16b asm to read the content of the BIOS keyboard buffer in Real Mode (sploitOS.S)

I-6) Verifying this bug exists “in real life” (2/2) :



- **Results :**
- Most BIOS Passwords are vulnerable (more on this later).
- ... if the BIOS Programmers themselves do not clear the BIOS keyboard buffer... just imagine third party programmers...

I-7) Password chaining :



- Let's now imagine we have two authentication devices in a row (asking for pass1 and pass2 respectively)....
- What happens in the BIOS keyboard buffer ?
- The passwords are concatenated ! So we can retrieve both ;)

[p][a][s][s][1][Enter][p][a][s][s][2][Enter]



SCOPE :

In the following two sections, we assume the OS has fully booted and the attacker is given a local shell, but no physical access.

II - Password leakage under Windows



- The Challenge
- Possible attack scenarii
- Reading the password from a guest account

II-1) The Challenge :



How to read the password at 0x40:0x1e ?
(once in protected mode...)



II-2) Possible attack scenarii :



- Get back to real-mode
- Switch to SMM
- Get it from kernel land

All those scenarii require very high privileges :(

II-3) Reading the password from a guest account :



- **The MS-DOS emulation mode :**
- built on top of x86 Vmode to emulate 16b execution
- Windows “feature” : maps physical memory ranges 0-FFF and C0000-FFFFFF into userland !!!
(<http://readlist.com/lists/securityfocus.com/bugtraq/1/9422.html>)



Demo

III – Password leakage under *nix



- Challenge
- Getting the password from user land
- Getting the password from kernel land
- Conclusion

III-1) Challenge :



- Unfortunately, no goodie like the RAM leakage under Windows... We will try to retrieve the password from a privileged (typically root) account...

III-2) Getting the password from user land (1/4):



- We know the address of the BIOS keyboard buffer in Physical Memory.
- under most flavors of Unix, /dev/mem contains a mapping of the Physical memory...

```
root@blackbox:~# xxd -l 32 -s 0x041e /dev/mem
000041e: 7019 3405 731f 731f 7711 300b 7213 6420 p.4.s.s.w.0.r.d
000042e: 0d1c 0d1c 0000 0000 0000 0000 0000 0000 .....
root@blackbox:~#
```

III-2) Getting the password from user land (2/4):



- /dev/kmem contains a mapping of kernel memory :
- /dev/kcore contains the same information in the

f

```
root@blackbox:~# dd if=/dev/kmem ibs=1 skip=3221226526 count=32 2>/dev/null|xxd
00000000: 7019 3405 731f 731f 7711 300b 7213 6420 p.4.s.s.w.0.r.d
00000010: 0d1c 0d1c 0000 0000 0000 0000 0000 0000 .....
```

```
root@blackbox:~# xxd -l 32 -s 0x141e /proc/kcore
000141e: 7019 3405 731f 731f 7711 300b 7213 6420 p.4.s.s.w.0.r.d
000142e: 0d1c 0d1c 0000 0000 0000 0000 0000 0000 .....
```

```
root@blackbox:~#
```

III-2) Getting the password from user land (3/4):



- We have coded a simple tool that will work under virtually any x86 based *nix (tested under OpenSolaris, FreeBSD, OpenBSD and GNU/Linux) to read the possible passwords from /dev/mem, but also /dev/kmem, /dev/kcore etc if available...

III-2) Getting the password from user land (4/4):



```
root@blackbox:/home/jonathan/userland-unix# ./generic.unix.sploit -m  
  
[ Bios keyboard buffer hysteresis generic userland exploit for *nix. ]  
// Jonathan Brossard - jonathan@ivizindia.com - endrazine@gmail.com  
  
Tested under several flavours of GNU/Linux, *BSD and Solaris.  
  
--[ Password (to the latest pre boot authentication software) : p4ssw0rd  
  
root@blackbox:/home/jonathan/userland-unix#
```

III-3) Getting the password from kernel land (1/3):



- The BIOS Data Area is copied to a “safe” zone during kernel early booting (the infamous “Zero Page”, cf: Setup.S in the Linux kernel).
- If you assume a 3Gb/1Gb kernel split, the address of the BIOS Keyboard buffer is :
`0xC000041e`

III-3) Getting the password from kernel land (2/3):



- Verifying that the password is located at 0xC000041e (using remote kernel debugging...)

```
root@blackbox:/home/jonathan# cd /usr/src/linux-2.6.19/
root@blackbox:/usr/src/linux-2.6.19# gdb ./vmlinux
GNU gdb 6.6-debian
Copyright (C) 2006 Free Software Foundation, Inc.
GDB is free software, covered by the GNU General Public License, and you are
(...)
gdb $ target remote 127.0.0.1:8832
[New Thread 1]
(...)
0xc0103db0 in apic_timer_interrupt ()
gdb $ x /1s 0xC000041E
0xc000041e:  "p\0314\005s\037s\037w\0210\vr\023d"
gdb $
```

III-3) Getting the password from kernel land (3/3):



- We have coded a simple LKM to automate the work and display the possible passwords in a new entry under the /proc pseudo-filesystem :

```
root@blackbox:/home/jonathan/ksplit-proc/src# insmod ./ksplit.ko
root@blackbox:/home/jonathan/ksplit-proc/src# cat /proc/prebootpassword
Password to the latest pre boot authentication software) : p4ssw0rd
root@blackbox:/home/jonathan/ksplit-proc/src#
```

III-4) Conclusion :



- This bug has been there since the very beginning of BIOS passwords (25+ years).
- Retrieving the password is as simple as reading a file at a given location... Open your eyes ;)



Demo

IV – Rebooting in spite of a pre-boot authentication password



- In some cases, it is handy for an attacker to reboot the computer (to boot a weaker kernel for instance). But if a pre-boot authentication device is on the way, this is a non trivial task...
- In the next section, we assume the attacker can write to the MBR (ie: typically root access) and is willing to reboot the computer.

IV – Rebooting in spite of a pre-boot authentication password



- **Agenda :**
- The password is not used to decrypt anything
- The password is used to decipher part of the disk or the whole disk.



IV-1) Rebooting in spite of a preboot authentication password without disk encryption (1/2):



- Since the password checking routine doesn't perform any useful task (from an attacker point of view), he can simply patch it.
- See phrack article “Hacking deeper in the system” by Scythale for a deeper analysis of Grub hacking).

IV-1) Rebooting in spite of a preboot authentication password without disk encryption (2/2):



```
[ LILO ]
```

UP	Gentoo-2.6.24		
UP	Gentoo-2.6.19		

enhanced lilo for extra fun

Kiss your pre-boot password goodbye...

```
boot:
Loading Gentoo-2.6.24.....
....._
```

IV-2) Rebooting with a password used for disk decryption :



- The BIOS keyboard buffer “feature” reloaded
- Attack scenario
- Methodology to install the rogue bootloader
- “Invisible Man” roadmap

IV-2-a) The BIOS keyboard buffer “feature” reloaded :



- **The Problem :**
- What happens if the BIOS keyboard buffer is not initialized ?
- If the attacker can somehow enter the password before the genuine bootloader prompts for a password, the authentication routine will decrypt the disk nicely ;)

IV-2-b) Attack scenario :

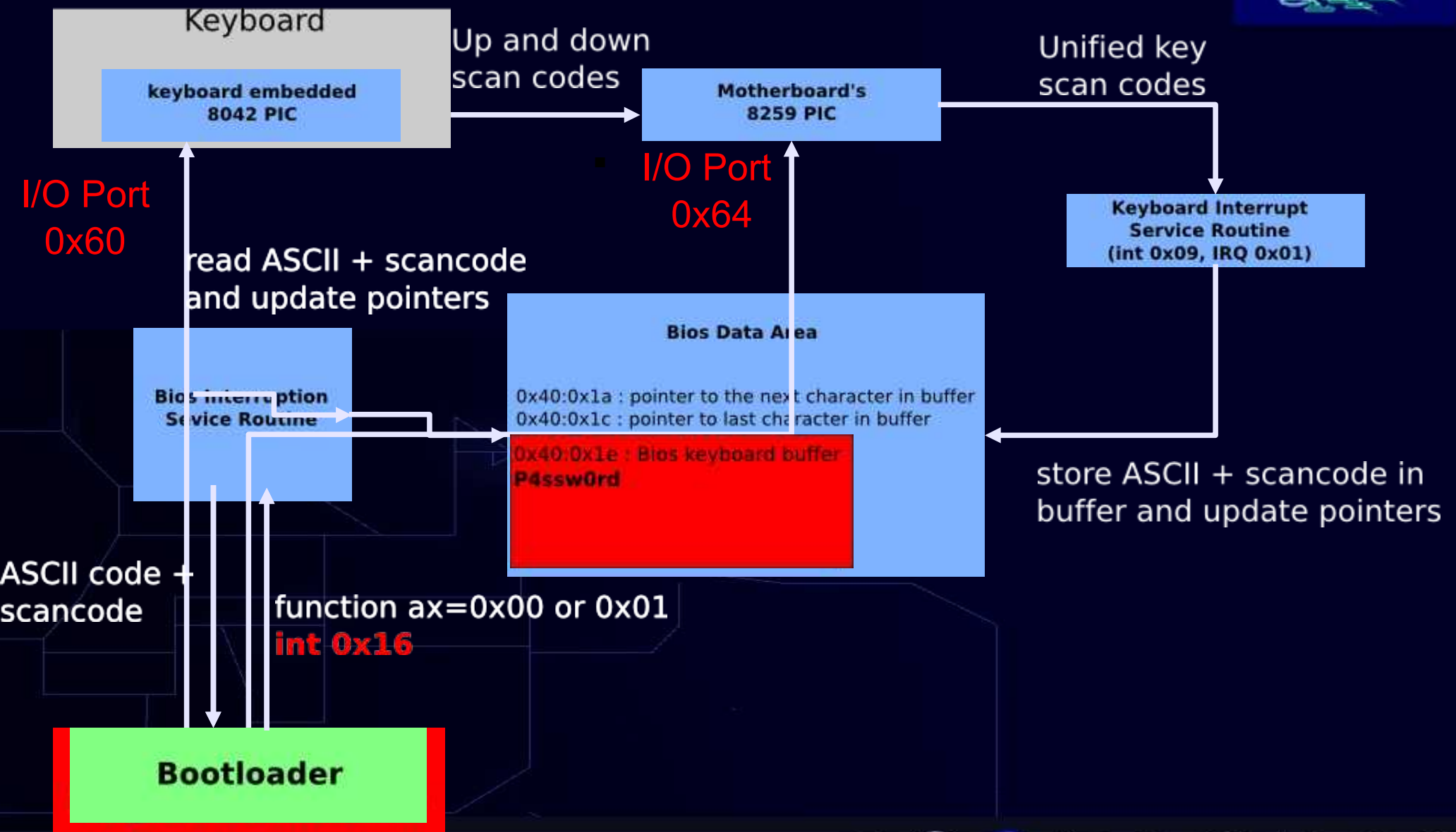

IV-2-c) Methodology to install the rogue bootloader :



- 1) Open the device in read/write mode.
- 2) Search for a 512b buffer to store a backup of the MBR.
- 3) Copy the first sector of disk to the backup buffer.
- 4) Find the initial jump to MBR's code.
- 5) Write our own payload to that address, preserving the partition table and the final 0xaa signature marking the disk as bootable.



IV-2-d) “Invisible Man” roadmap :

- 1) Use a delta offset trick to find our own location in memory.
- 2) Fill the Bios keyboard buffer using PIC 8048 and PIC 8259 programming.
- 3) Allocate a 10Ko buffer in the free RAM reserved to the BIOS.
- 4) Find the first bootable disk by checking if it is marked as bootable.
- 5) Read the first 20 sectors of disk in reserved free RAM.
- 6) Patch the disk with the backed up MBR.
- 7) Jump to our own code copied in RAM.
- 8) Load the old MBR in Ram at address 0x0000:0x7c00 .
- 9) Unallocate the reserved Bios memory if possible.
- 10) Jump to original bootloader's entry point at 0x0000:0x7c00 .



Demo



V – Examples of vulnerable softwares...



V-1) Vulnerable Softwares (1/3):



- **BIOS passwords :**
- Award BIOS Modular 4.50pg
- Insyde BIOS V190
- Intel Corp
PE94510M.86A.0050.2007.0710.1559
- Hewlett-Packard 68DTT Ver. F.0D (11/22/2005)
- IBM Lenovo 7CETB5WW v2.05 (10/13/2006)

V-1) Vulnerable Softwares (2/3):



- **Full disk encryption with pre-boot authentication capabilities :**
- Bitlocker with TPM chip under Microsoft Vista Ultimate Edition SP0.
- Truecrypt 5.0 for Windows (open source)
- DiskCryptor 0.2.6 for Windows (open source)
- Secu Star DriveCrypt Plus Pack v3.9

V-1) Vulnerable Softwares (3/3):



- **Boot loader passwords :**
- grub (GNU GRUB 0.97) (latest CVS)
- lilo version 22.6.1 (current under Mandriva 2006)

V-2) Non vulnerable Softwares (1/2):



- **BIOS Passwords :**
- Hewlett-Packard F.20 (04/15/2005)
- Hewlett-Packard F.05 (08/14/2006)
- Pheonix BIOS Version F.0B, 7/3/2006
- Phoenix Technologies LTD R0220Q0 (25-05-2007)

V-2) Non vulnerable Softwares (2/2):



- **Full disk encryption with pre-boot authentication capabilities :**
- SafeGuard 4.40 for Windows
- PGP Desktop Professional 9.8 for Windows (Trial Version)

VI) Mitigating those vulnerabilities :



- Write correct software : sanitize the BIOS keyboard buffer (and more generally any password buffer) before and after use...
- We keep a list of patches on our website : <http://www.ivizindia.com/BIOS-patches/> (contributions are most welcome).
- For GNU/Linux users, the latest version of Grsecurity (<http://www.openwall.net>) sanitizes the BDA at boot time (thanks to Brad for this).

Greetings :



- My uber elite reviewers (you know who you are) : many thanks guys :)
- The iViZ Technical Team for your support and the time spent on testing software.
- <http://www.everybody-dies.com/> web site for letting me use the screenshots of their game “Defcon : everybody dies !” in my slides ;)
- irc.pulltheplug.org and irc.blacksecurity.org...
- All of you for coming to this presentation.
- The Defcon Staff for the awesome event and parties...



Thank you !

Questions ?