



**HAL**  
open science

# Identification and listing of operation research problems in the framework of heterogeneous robotic swarms in System-of-Systems: a path for consistent research targets

Lorraine Brisacier- Porchon, Omar Hammami

## ► To cite this version:

Lorraine Brisacier- Porchon, Omar Hammami. Identification and listing of operation research problems in the framework of heterogeneous robotic swarms in System-of-Systems: a path for consistent research targets. IEEE System-of-Systems Conference 2024, Jun 2024, Tacoma, United States. hal-04584786

**HAL Id: hal-04584786**

**<https://hal.science/hal-04584786>**

Submitted on 23 May 2024

**HAL** is a multi-disciplinary open access archive for the deposit and dissemination of scientific research documents, whether they are published or not. The documents may come from teaching and research institutions in France or abroad, or from public or private research centers.

L'archive ouverte pluridisciplinaire **HAL**, est destinée au dépôt et à la diffusion de documents scientifiques de niveau recherche, publiés ou non, émanant des établissements d'enseignement et de recherche français ou étrangers, des laboratoires publics ou privés.

# Identification and listing of operation research problems in the framework of heterogeneous robotic swarms in System-of-Systems: a path for consistent research targets

\*Note: Sub-titles are not captured in Xplore and should not be used

Lorraine BRISACIER-  
PORCHON  
KNDS FRance

Versailles, France  
[brisacier.lorraine@gmail.com](mailto:brisacier.lorraine@gmail.com)

Omar HAMMAMI  
Institut Polytechnique de Paris  
ENSTA Paris, U2IS)  
Palaiseau, France  
[omar.hammami@ensta-paris.fr](mailto:omar.hammami@ensta-paris.fr)

**Abstract**— Recent events in Ukraine revealed the progression of robotic systems on battlefield, both aerial and ground systems that answer various capabilities. Heterogeneous unmanned systems acting in swarms are being tested on field and are evaluated through defense challenges. The capabilities and system views are exposed using a set of NATO Architecture Framework (NAF) 3.1 views. Based on field experience, we expose a selection of interconnected views of our systems, capabilities and operational activities in unstructured environment. The core idea of this paper is to introduce operation research (OR) problems that could be tackled to our views generation, so that any heterogeneous robotic swarm (HRS) architecture can be seen as a system-of-systems. Finally, by introducing those system-of-system architecting activities, we share insight on how HRS design is a highly multi-physical compromise to reach, that can only be improved over time if all multi-physical aspects of the system are considered.

**Keywords**—System-of-systems, Swarms, COTS, Architecture Frameworks, Return on experience

## I. INTRODUCTION

Recent events in Ukraine have shown the necessity to develop low-cost constituent systems that can work in high-tech collaborative framework. A particular focus is made on design and usage of drones and unmanned ground vehicles (UGV) that can create major destruction over million-euro main battle tanks. In order to create efficient system-of-systems with respect to specific list of capabilities, defense and aerospace systems builders are currently developing digital engineering methods. The development of workflows adapted to each line of products is an investment in itself which enterprises want to use most efficiently so that return on investment estimates guarantees economic success as soon as possible. In defense and aerospace context, planification of system lifecycle commonly reach 40 to 50 years lifecycle, from early sketch to dismantlement. However, major defense industries often participate to robotic challenges to show their innovative technologies. It is also the

place for ministries of defense of those countries to evaluate doctrinal concepts on real-size examples in combat conditions, and to encourage technology development inclusion in existing collaborative combat configurations.

If Model Based System Engineering (MBSE) practice has been a major trend in current publications since 2013 [1], practitioners still face emerging resistance to its adoption [2]. On the other hand, to paraphrase [3], swarm robotic design still lacks of engineering process standardization. It means that for instance, behavior designed for a specific robot must be completely redesigned to work in a different model. They claim that in absence of universal standards to reach for hardware and mechanical design interoperability of platforms, improvement of perception or software on individual platforms will not enable an up-scale of robotic swarms. We mean to add to these observations that defense industry could benefit from closing the gap between systems engineering and robotic swarms, so that new platform introduction in existing system-of-systems actually contributes to capabilities on field and adds new operational scenarii. It could lead to extensive usage of reliable estimates of swarms tactical impact as described in [4], considering realistic constraints issued from field.

To the best of our knowledge, presenting military robotic challenges using DoDAF, MoDAF or NAF in either version is unknown in the robotic field. Yet there is a need to specify drones and UGV collaborations capabilities with formally designed constraints in scheduling, costs and quality.

Hence this article provides details of return on experience (RETEX) model using NAF v3.1, and introduces problems in operation research (OR) to tackle to those interconnected views so that heterogeneous swarms design can be seen as a Quality, Resource and Time <Q,R,T> general compromise.

## II. STATE-OF-THE ART IN ROBOTIC SWARMS AND SYSTEM OF SYSTEMS

### A. Robotic swarms, methods and collective behaviors

Reference [5] introduces “the main characteristics of a swarm robotics system are the following:

- robots are autonomous;
- robots are situated in the environment and can act to modify it;
- robots’ sensing and communication capabilities are local;
- robots do not have access to centralized control and/or to global knowledge;
- robots cooperate to tackle a given task. “

In [6], a swarm is also depicted as a “type of multi-agent system”. It means that deployment of a swarm is recognized as a system. Furthermore, it means that our challenge including a constraint to have more platforms than operators are meant to be swarms so that capabilities can be achieved.

For example, there are Partially Observable Markov decision processes [7] « modeling and solving robot decision and control tasks under uncertainty. ». There again, we were unable to track publications that involve return on experience from field tests using COTS platforms, even though we believe that major failures originates from unexpected COTS behavior [8].

Another type of publications rather focuses on algorithmic design in order to create specific more or less directed behavior. We commonly find particle swarms optimization [9], or ant-like behavior algorithms, for example, that depict

While most of literature focus on strategic software design and best algorithms to fit some ant-like, molecular-like, to the best of our knowledge, there is little information concerning multi-physical overall compromises that have to be made to integrate, verify or validation of robot swarms to achieve capabilities.

We believe that casting a set of architectural views on swarm systems to fit in robotic challenge is a novel approach that could lead to answer the call for “conditions for massive real-world deployment” mentioned in review of past, present and future on robotic swarms [10]. We believe, to paraphrase their conclusions, that current issues related to the hardware of robot swarms are a priority to achieve scaling up to real world applications.

A recent survey [11] called *UAV Swarm Intelligence: Recent Advances and Future Trends* contains the dimension of fields that would be required to test implementation, and willingly represent some football field. However, it gives no details on weather, atmospheric pressure, soil types or vegetal coverage of such a field, which makes the conditions of the tests less realistic for defense robots.

### B. From heterogeneous swarms to system-of-systems architecture

To the best of our knowledge, HRS advances is yet weakly connected to system-of-systems practice. There are yet little reference to Maier principles issued in 1998, and no relations openly established with emergence concept from ISO/IEC/IEEE

21840:2019 [12] “principle that entities exhibit properties which are meaningful only when attributed to the whole, not to its parts”. In a world claiming advances in artificial intelligence in the specific field of defense robot swarms, we raise the following questions:

1. With the appearance embedded autonomous functions, can we accept sending on the field platforms with unpredictable behavior?
2. To what extent improvement of performance in one required field contributes to the desired capability of the HRS system?

However, [13] opens its 4<sup>th</sup> chapter detailing what system-of-systems are. “From ISO/IEEE/IEC 21839 (2019) defines a System of Systems (SoS) as:

*A set of systems or system elements that interact to provide a unique capability that none of the constituent systems can accomplish on its own.*

*Constituent systems can be part of one or more SoS. Each constituent system is a useful system by itself, having its own development, management goals, and resources, but interacts within the SoS to provide the unique capability of the SoS (ISO/IEEE/IEC 21839, 2019).*

*The following characteristics can be useful when deciding if a particular SoI can better be understood as an SoS [14] (Maier, 1998):*

- Operational independence of constituent systems;
- Managerial independence of constituent systems;
- Geographical distribution;
- Emergent behavior;
- Evolutionary development processes.

*Of these, operational independence and managerial independence are the two principal distinguishing characteristics for applying the term SoS”*

Highlighting those definitions that any questions raised from swarm robotic state-of-the-art may be addressed using system-of-systems. Indeed, we suggest providing model-based architecting ontology to switch point of views in how swarms are designed and create opportunities to integrate them on battlefield as contributors to given capabilities in an overall enterprise, such as described in our robotic challenge.

### C. System-of-systems modeling using optimization

In “System-of-Systems Architecture Selection: A Survey of Issues, Methods, and Opportunities” [15], the authors expose the complete works in swarm behavior prediction in system-of-system literature. This research points out the lack of high-quality data and what we consider a lack of complexity assessment, with which we wish to tackle the need for optimization and for the creation of extensions to any existing architecture frameworks (AF).

On the other hand, “MBSE does not change the practice of Systems Engineering as defined in the INCOSE SE Handbook, but it does affect the way in which systems engineering processes are implemented and supported within and across

organizations” [16]. Through those observations, we encourage massive usage of specified ontologies.

We selected NAF v3.1 [17] because of its ready-to-use defense system ontology with costs and delays representations [18], and because we already had artefacts in NAF 3.1 that represent the system-of-system in which the swarm is to be inserted. We consider that the framework, implemented in CATIA Magic [19], is reasonable choice. However, we will also share some views and artefacts that were built using MEGA HOPEX for NAF 2R1, such as in Figure 6, because we wanted to re-use previous project views.

NAF v3.1 presents 49 views that share artifacts, which makes the meta-model of NAF models composed of interconnected nodes. offers the constellation formed of all views. In this illustration of ready-to-use possibilities, a directed connection between two nodes means we want to convey an artefact from a starting node to another.

In system-of-systems, modeling using AF and optimization is not novel practice: [20] exposes a sub-set of United Architecture Framework (UAF) and recommends to set capabilities into objectives. Since we follow those recommendations, it allows us to create optimization models in parallel of our AF. Our capabilities “to recognize a position or a zone” and “to capture a position or a zone”, depicted in our enterprise vision in Figure 1, are associated with various categories of constraints : constraints on the field, to execute the capability in limited time and geographical aspects for operators on field, and development constraints, imposed to architects by the milestones of the challenges. We believe that this example set-up on different levels, associated to different stakeholders responsibilities scales up to any SoS design in any context.

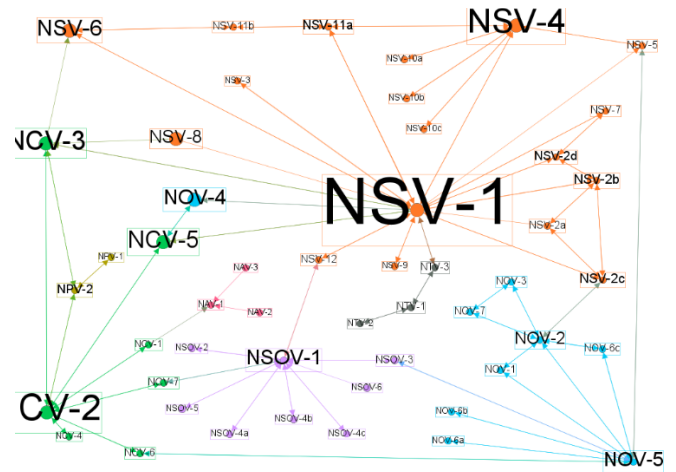

Figure 2:meta-model of NAF 3.1 : a constellation of 49 nodes, colored with different viewpoints

### III. RETURN ON EXPERIENCE (RETEX) AND MODELS

#### A. “MOMDKP+OAC”: Details on capability/objectives and impact of new constraints on-the-go

We detail here our capability views: enterprise vision and capability taxonomy. Other views and specific associated workflow will be presented in [8], especially NCV-3, capability phasing, which we explore in detail in our other publication. We consider that any effort in engineering HRS should be a contribution to capability realization. Enterprise vision in Figure 1 connects both milestones to consider for system architects, and requirements in performance associated to a more general perspective. This view can be used to pose one problem in a logic where system modeling at high level should be used to drive all decisions for the architect: the architect activities

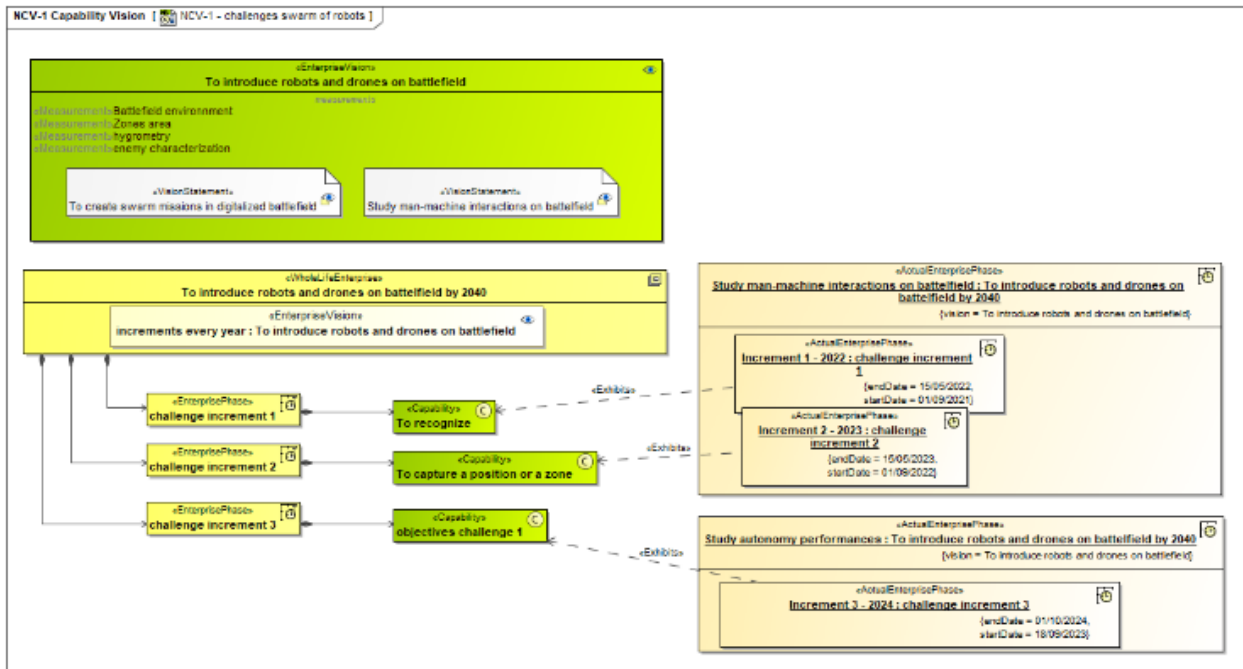

Figure 1: enterprise vision and capability increments inspired by challenges on HRS

outcome (i.e. realization of the mission) is part of the objectives set for the system itself. In other words, the system has to achieve its mission on schedule on both levels. We already have presented how selection of a set of robots can be seen as a multi-objective and multi-disciplinary Knapsack problem (MOMDKP) [21]. However; we will detail here how its association with system-of-systems architecture makes it an original problem even in OR practice.

Because realization of capabilities/objectives on D-Day depend on choices and strategies delivered during architecting activity, we define this phenomenon as “online arbitrary”.

On Figure 3, we focus on the capabilities that were executed by our swarms on the day of the challenge. Note that both “increments” had to be executed with different constraints, which impact the MCMDKP optimization model behind HRS system architecting activity. We changed our swarming strategy in the second increment, because the organizers imposed new constraints on-the-go in terms of autonomy of the swarm: they imposed a reduction of the number of operators executing the capabilities. In OR, we consider that adding constraints between increments changed our architecting strategy, and re-using our previous works was uneasy. It added an amount of work that would not have happened without that constraints.

Note that on battlefield, changing the constraints on-the-go due to technical observations or strategy adjustments is realistic. If tactical impact of robot swarms on field [4] can be estimated in past contexts, it does not necessarily imply that the swarm is fit for a new conception space.

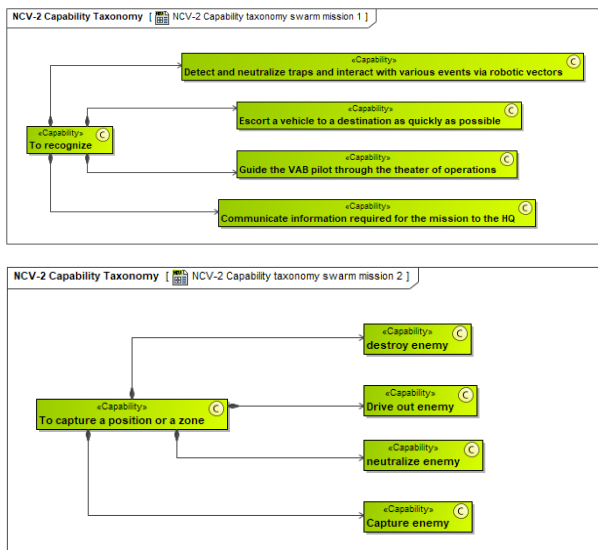

Figure 3: zoom on capabilities issued in the challenge

We decided to expose in this article a new problem, that would be called “MCMDKP+OAC”, adding online arbitrary constraints (+OAC) to the creation of possible architectures.

In Figure 4, we expose in details the architecture of human-swarms interactions that we implemented as defined in [22]. Indeed, the capability to achieve “To recognize” required 4 pilots for 4 platforms. In the second increment, “To capture a

position or a zone”, our architecture required 4 pilots for 5 platforms.

In associating MCMDKP+OAC, we deliver satisfactory optimization modeling: it still stands if the online constraint modification was a change of set-up, such as capability zone execution modification. However, to the best of our knowledge, solving an MCMDKP+OAC may be NP-Hard problem to solve, as much as many MCMDKP, and has yet to be solved in OR.

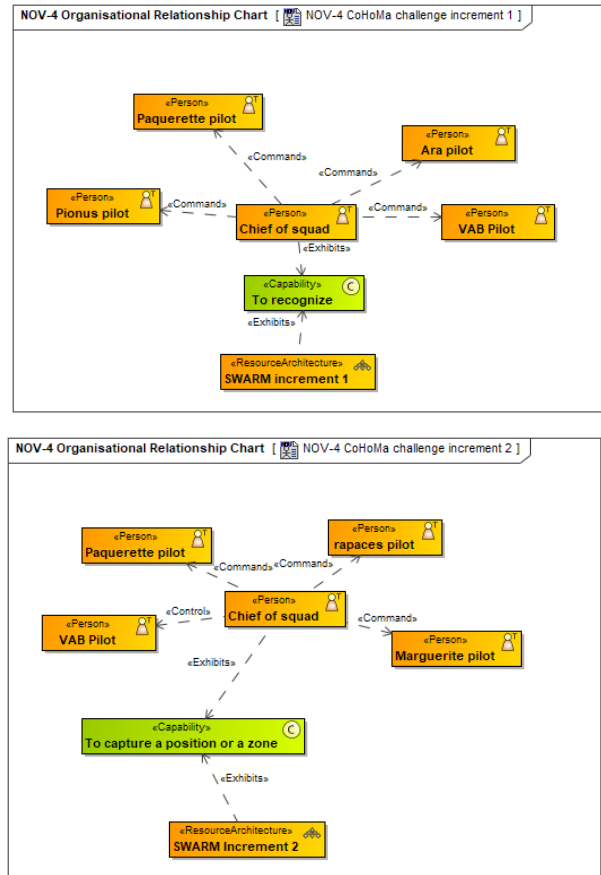

Figure 4: The different operational stakeholder architectures that were created over both increments

B. “MCMDSP+ADYN”: unpredictable occurring problems that may be assessed with respect to objectives

We present in this section a detail on operational views. In NOV-6b, we intend to expose Operational State transition descriptions dynamic behavior. It means that NOV-6b can model states in which individual systems can fall into, but also how the overall system state can be described. In this example, we share example of what both could look like.

In Figure 5, we modeled the states on one individual platform, with generic stages that can fit all platforms, either flying or on the ground. From the chief point of view of the overall maneuver, only one information is needed: the real-time situation of its assets on battlefield. What differs from a platform to another is the cause that can put a system out of service and the way information is updated in the HRS system. Indeed,



“problem” could be detected from either another element of the swarm or sent by the individual itself.

Our point here is to show that building a strategy to react in case of emergency is also a responsibility of the architect. The real-time nature of this problem introduces the idea of using variations of “multi-criteria, Multi-Dimensional Scheduling problem” (MCMDSP), which is also known in OR as an NP-Hard problem to solve.

What is new here is the addition of arbitrary dynamics (ADYN). If we want to elaborate a strategy to face those problem occurrences, we need to explore those causes. We previously exposed issues and problems that result from obsolete information in [23], and more recently on robotic swarms in [8], and we believe that those observations add to ADYN causes that could be explored.

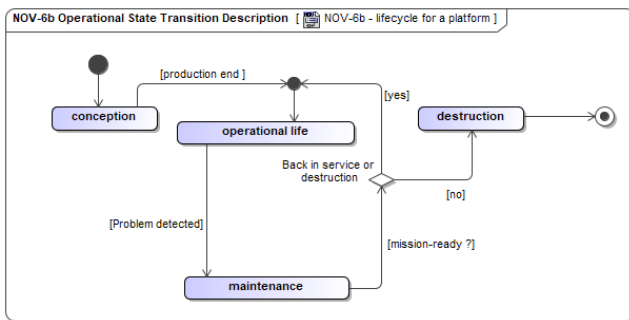

Figure 5: example of operational lifecycle of one of the platforms

Furthermore, the introduction of HRS systems in existing system-of-systems will induce following the same standards in mechanical scenarii. It means that scenarii issued in NATO MIL-STDs that describe precise scenarii will have to be questioned in AF modelling. We explored in our example another NOV-6b view designed in Figure 6. Undertaking the task to unveil OR problems in the light of system-of-systems visions will help reveal which scenarii will impact capability realization the most.

Solving MCMDSP+ADYN, even in approximate solutions, should also be an activity to introduce the importance of multi-physical representations that cause those eventual failures. Indeed, without improvement on modeling multi-physical aspects of system dynamic behavior, we will not be able to foresee swarm behavior on battlefield, or to capitalize fielded data.

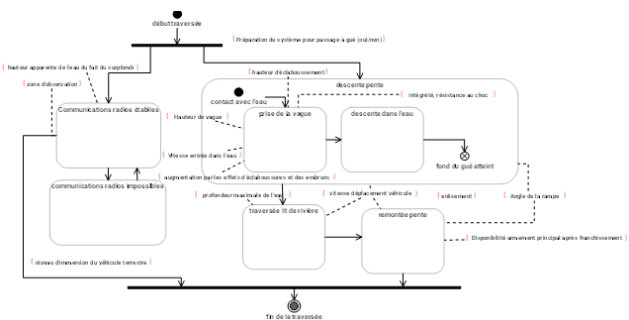

Figure 6: NOV 6b overall shape to illustrate fording capabilities from MIL-STD-2805 v5

Looking for overall compromises through MCMDSP-ADYN would also help finding in certain conditions the minimal number of platforms contributing to the capability realization that is required in an undefined environment is also unknown. It would also help in measuring the diversity of platforms required to reach those objectives. However, representations from our RETEX indicate that operational views are not multi physical enough to enable trustworthy architectures. In our Figure 6, fording ability of the system in terms of mechanical and material attributes are not part of the set of predefined representations in NAF 3.1.

*C. Health and Usage Monitoring Systems(HUMS) can only be designed if information from sensors are reliable, and HRS systems failures cannot be predictable*

In our previous publications, we exposed a set of optimization problems using MCMDKP [24]. In this research, we proposed an introduction of MDAO practice in the elaboration of individual robotic platforms. In this contribution, we expose an application of the previous conclusions to specific HRS, seen as system-of-systems. Indeed, the specifications and representations of each system view internal diagrams can be stored in the model as illustrated in Figure 7.

We depict here our selected allocation of technology principles, that we repeated on all our platforms. The issue here is that if an electrical problem occurs and burns the motherboard during the capability realization, the swarm will never know what happened, because an offline system will not be recognized by the swarm. In that case, even if the swarm contains some technology to “train” to react in an appropriate way, we expect it to be embedded, so that the swarm stays automated. In that sense, “training” should at least contain:

- failures that can happen from a similar environment
- failures that can happen from similar internal system design

In order to train properly those swarm behaviors, a certain level of details from system architecture (topology of sensors positions, energy consumption) and from the field meteorological conditions and geographical specificities should be included.

Last, any discussion issued to introduce HUMS technology will take us back either to adding sensors, which results in adding constraints online on the MCMDKP-OAF cited in the previous paragraph, or to add a new arbitrary online objective (AOO) to the multi-objectives cited. This problem can be formulated as MCMDKP-AOO.

To the best of our knowledge, creating bankable HUMS solutions on systems that preserves HRS system-of-systems capability realization is yet another NP-Hard problem to solve.

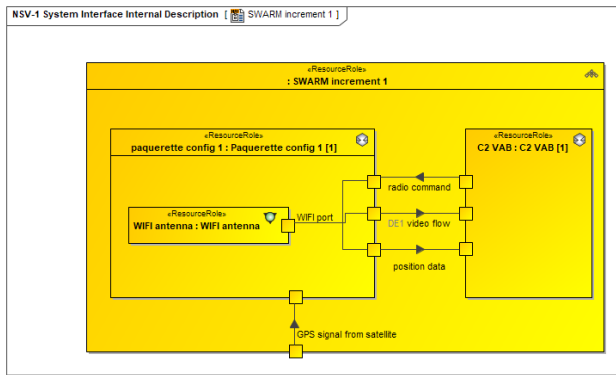

Figure 7: NSV-1, the internal description of our SWARM increment 1

#### IV. IMAPCTS AND OUTLOOK

Our contribution offers a new perspective on existing practice in engineering, and describe existing SE or architecting problems as OR. Those new perspectives are based on MBSE using NAF 3.1, but we invite our audience to revisit their own practice with other modeling approaches and frameworks with the new OR-based perspective introduced in our contribution, counting in objectives and constraints, which could unlock theoretical barriers that blind architects from realistic simulation or  $\langle Q, R, T \rangle$  budget estimation.

The observations made from our views and artefacts creation were tackled to various problems in optimization that have yet to be solved. Indeed, we believe that Operation Research (OR) and decision aid could be driven to find out the class of problems exposed in this RETEX. When the workflow is continuous, we believe that most of them are nonlinear, sometimes strongly NP-Hard, as defined in computational theory.

We stated from our RETEX views some problems that can be turned into equations in OR that we would be interested in solving to enable industrialization of HRS system-of-systems and include them in digitized battlefields. We believe that it unveils promising stepping stones to solve some unresolved issues.

On overall outlook, approximate solutions to the problems provided here are necessary to create  $\langle Q, R, T \rangle$  balanced system architectures. At least MCMDKP-OAF, MCMDKP-AOO, MCMDSP-ADYN and MCMDKP-MVF could be seen as the missing link between robotic swarms engineering and systems engineering. Solving those problems, even approximately, could answer questions of compromises rather than domain-specific techniques, which is precisely the issue identified in state-of-the-art of robotic swarms engineering.

If those problems prove to be NP-Hard, then answering them using best effort experience from past projects is insufficient, and perhaps counter-productive. Maximizing the execution of one domain from all domains, i.e. introducing new technology that raises standards for one domain only without measuring its consequences on the overall compromise may be doomed to fail.

It seems like “best effort” shown in both challenge increments could be replaced with optimization-based AF. At the same time, tackling AF-based problem formulation to existing OR problems will open new research outlook in OR

field. This article provides a new vision on how to revisit existing swarm robotics from a system-of-systems point of view, and gives theoretical propositions so that the discipline scales up to reach the bare requirements to build industrial considerations to swarm robotics in the defense sector.

In our future research, we might be able to use optimization results in a Pareto Front to provide realizable architectures in a  $\langle Q, R, T \rangle$  bounded envelope. From this portfolio, calling to decision aid algorithms such as game theory for instance will be consistent. However, for decision aid (DA) algorithms to be effective, it requires input data that will not lead to push the constraints of  $\langle Q, R, T \rangle$ .

#### V. CONCLUSIONS

Integration of new software and hardware in embedded systems to drive innovative swarm performances on battlefield will be costly, and the expense to reach overall compromises can only be estimated if hypothesis hold. Optimization brings a set of tools that enables growing upscale and reach compromises associated with their objectives and constraints. Most of those problems in optimization can be identified as NP-hard, and we raise questions so that system engineering practice with AF address those questions with adequate resolution algorithms.

We presented works on illustrative cases, inspired from our performance during incremental robotic capability challenge. We observed that System-of-system approach is absent from robotic publication fields, and we propose to connect SE principles to challenges rose from robotic expectations in order to reach Quality, Time, Resource  $\langle Q, R, T \rangle$  compromises, so that exploration of undefined behavior on varying climatic conditions can keep up to our ambitions to bring any acknowledged or directed system-of-systems to become advantageous on battlefield.

#### REFERENCES

- [1] S. Wolny, A. Mazak, C. Carpella, V. Geist, and M. Wimmer, ‘Thirteen years of SysML: a systematic mapping study’, *Softw. Syst. Model.*, vol. 19, no. 1, pp. 111–169, Jan. 2020, doi: 10.1007/s10270-019-00735-y.
- [2] K. Henderson, T. McDermott, and A. Salado, ‘MBSE adoption experiences in organizations: Lessons learned’, *Syst. Eng.*, p. sys.21717, Aug. 2023, doi: 10.1002/sys.21717.
- [3] N. Nedjah and L. S. Junior, ‘Review of methodologies and tasks in swarm robotics towards standardization’, *Swarm Evol. Comput.*, vol. 50, p. 100565, Nov. 2019, doi: 10.1016/j.swevo.2019.100565.
- [4] K. L. Foster and M. D. Petty, ‘Estimating the tactical impact of robot swarms using a semi-automated forces system and design of experiments methods’, *J. Def. Model. Simul. Appl. Methodol. Technol.*, vol. 18, no. 3, pp. 247–269, Jul. 2021, doi: 10.1177/15485129211008532.
- [5] M. Brambilla, E. Ferrante, M. Birattari, and M. Dorigo, ‘Swarm robotics: a review from the swarm engineering perspective’, *Swarm Intell.*, vol. 7, no. 1, pp. 1–41, Mar. 2013, doi: 10.1007/s11721-012-0075-2.

- [6] R. Arnold, K. Carey, B. Abruzzo, and C. Korpela, 'What is A Robot Swarm: A Definition for Swarming Robotics', in *2019 IEEE 10th Annual Ubiquitous Computing, Electronics & Mobile Communication Conference (UEMCON)*, New York City, NY, USA: IEEE, Oct. 2019, pp. 0074–0081. doi: 10.1109/UEMCON47517.2019.8993024.
- [7] M. Lauri, D. Hsu, and J. Pajarinen, 'Partially Observable Markov Decision Processes in Robotics: A Survey', *IEEE Trans. Robot.*, vol. 39, no. 1, pp. 21–40, Feb. 2023, doi: 10.1109/TRO.2022.3200138.
- [8] L. Brisacier-Porchon and O. Hammami, 'Modeling swarm mission with COTS characterization: a series of return on experience', presented at the 34th Annual INCOSE International Symposium, Dublin, Ireland, Jul. 2024.
- [9] S. Spanogianopoulos, 'Particle Swarm Optimization and Applications in Robotics: A Survey', in *2018 9th International Conference on Information, Intelligence, Systems and Applications (IISA)*, Zakynthos, Greece: IEEE, Jul. 2018, pp. 1–7. doi: 10.1109/IISA.2018.8633635.
- [10] M. Dorigo, G. Theraulaz, and V. Trianni, 'Swarm Robotics: Past, Present, and Future [Point of View]', *Proc. IEEE*, vol. 109, no. 7, pp. 1152–1165, Jul. 2021, doi: 10.1109/JPROC.2021.3072740.
- [11] Y. Zhou, B. Rao, and W. Wang, 'UAV Swarm Intelligence: Recent Advances and Future Trends', *IEEE Access*, vol. 8, pp. 183856–183878, 2020, doi: 10.1109/ACCESS.2020.3028865.
- [12] 'ISO/CEI/IEEE 21840:2019 Systems and software engineering — Guidelines for the utilization of ISO/IEC/IEEE 15288 in the context of system of systems (SoS)'. Dec. 2019.
- [13] INCOSE, *INCOSE Systems Engineering Handbook 5th*, WILEY. 2023.
- [14] M. W. Maier, 'Architecting principles for systems-of-systems', *Syst. Eng.*, vol. 1, no. 4, 1998.
- [15] Z. Fang, 'System-of-Systems Architecture Selection: A Survey of Issues, Methods, and Opportunities', *IEEE Syst. J.*, vol. 16, no. 3, pp. 4768–4779, Sep. 2022, doi: 10.1109/JSYST.2021.3119294.
- [16] B. L. Papke, G. Wang, R. Kratzke, and C. Schreiber, 'Implementing MBSE – An Enterprise Approach to an Enterprise Problem', *INCOSE Int. Symp.*, vol. 30, no. 1, pp. 1539–1556, Jul. 2020, doi: 10.1002/j.2334-5837.2020.00803.x.
- [17] NATO, Ed., 'NATO ARCHITECTURE FRAMEWORK Version 3.1'. 2007.
- [18] N. Sarda, R. Estanguet, and D. Ernadote, 'Model-based approach to support Multi-Disciplinary Analysis and Optimization capability governance at enterprise level: preliminary results',
- [19] Dassault Systemes, 'CATIA Magic'. [Online]. Available: <https://www.3ds.com/fr/produits-et-services/catia/produits/catia-magic/>
- [20] C. G. Rubio and T. Rigaut, 'An Urban Air Mobility System of Systems UAF & MDAO Application Case',
- [21] L. Brisacier-Porchon and O. Hammami, 'Coupling Architecture Framework and Operation Research: the Case of NAF with Cost and Delay Driven Multi-Criteria Scheduling', presented at the SoSE 2022, Rochester, NY, USA, Jun. 2022.
- [22] A. Kolling, P. Walker, N. Chakraborty, K. Sycara, and M. Lewis, 'Human Interaction With Robot Swarms: A Survey', *IEEE Trans. Hum.-Mach. Syst.*, vol. 46, no. 1, pp. 9–26, Feb. 2016, doi: 10.1109/THMS.2015.2480801.
- [23] L. Brisacier-Porchon and O. Hammami, 'Inconsistent and Incomplete Datasheet: The case for systematic use of requirement engineering', presented at the 32nd Annual INCOSE International Symposium, Detroit, Michigan, Jun. 2022, p. 17.
- [24] L. Brisacier-Porchon and O. Hammami, 'Tackling optimization and system driven engineering in coupling physical constraints with MBSE: the case of a Mobile autonomous line of products', presented at the Conference on System Engineering and Research, Hoboken, NJ, USA, Mar. 2023.