



**HAL**  
open science

## **Kinematic features of whole-body reaching movements underwater: Neutral buoyancy effects**

T. Macaluso, C. Bourdin, F. Buloup, M.-L. Mille, P. Sainton, F.R. Sarlegna,  
Virginie Taillebot, J.-L. Vercher, P. Weiss, L Bringoux

► **To cite this version:**

T. Macaluso, C. Bourdin, F. Buloup, M.-L. Mille, P. Sainton, et al.. Kinematic features of whole-body reaching movements underwater: Neutral buoyancy effects. *Neuroscience*, 2016, 327, pp.125-135. 10.1016/j.neuroscience.2016.04.014 . hal-04517551

**HAL Id: hal-04517551**

**<https://hal.science/hal-04517551>**

Submitted on 22 Mar 2024

**HAL** is a multi-disciplinary open access archive for the deposit and dissemination of scientific research documents, whether they are published or not. The documents may come from teaching and research institutions in France or abroad, or from public or private research centers.

L'archive ouverte pluridisciplinaire **HAL**, est destinée au dépôt et à la diffusion de documents scientifiques de niveau recherche, publiés ou non, émanant des établissements d'enseignement et de recherche français ou étrangers, des laboratoires publics ou privés.

# KINEMATIC FEATURES OF WHOLE-BODY REACHING MOVEMENTS UNDERWATER: NEUTRAL BUOYANCY EFFECTS

T. MACALUSO,<sup>a</sup> C. BOURDIN,<sup>a</sup> F. BULOUP,<sup>a</sup>  
M.-L. MILLE,<sup>a,b,c</sup> P. SAINTON,<sup>a</sup> F. R. SARLEGNA,<sup>a</sup>  
V. TAILLEBOT,<sup>d</sup> J.-L. VERCHER,<sup>a</sup> P. WEISS<sup>d</sup> AND  
L. BRINGOUX<sup>a\*</sup>

<sup>a</sup> Aix-Marseille Université, CNRS, ISM UMR 7287, 13288  
Marseille Cedex 09, France

<sup>b</sup> Université de Toulon, 83957 La Garde, France

<sup>c</sup> Department of Physical Therapy and Human Movement  
Sciences, Northwestern University Medical School, Chicago,  
IL 60611, United States

<sup>d</sup> COMEX S.A., 36 Bvd des Océans, 13009 Marseille, France

**Abstract**—Astronauts' training is conventionally performed in a pool to reproduce weightlessness by exploiting buoyancy which is supposed to reduce the impact of gravity on the body. However, this training method has not been scientifically validated yet, and requires first to study the effects of underwater exposure on motor behavior. We examined the influence of neutral buoyancy on kinematic features of whole-body reaching underwater and compared them with those produced on land. Eight professional divers were asked to perform arm reaching movements toward visual targets while standing. Targets were presented either close or far from the subjects (requiring in the latter case an additional whole-body displacement). Reaching movements were performed on land or underwater in two different contexts of buoyancy. The divers either wore a diving suit only with neutral buoyancy applied to their center of mass or were additionally equipped with a submersible simulated space suit with neutral buoyancy applied to their body limbs. Results showed that underwater exposure impacted basic movement features, especially movement speed which was reduced. However, movement kinematics also differed according to the way buoyancy was exerted on the whole-body. When neutral buoyancy was applied to the center of mass only, some focal and postural components of whole-body reaching remained close to land observations, notably when considering the relative deceleration duration of arm elevation and concomitant forward trunk bending when reaching the far target. On the contrary, when neutral buoyancy was exerted on body segments, movement kinematics were close to those reported in weightlessness, as reflected by the arm deceleration phase and the

whole-body forward displacement when reaching the far target. These results suggest that astronauts could benefit from the application of neutral buoyancy across the whole-body segments to optimize underwater training and acquire specific motor skills which will be used in space. © 2016 The Authors. Published by Elsevier Ltd. on behalf of IBRO. This is an open access article under the CC BY-NC-ND license (<http://creativecommons.org/licenses/by-nc-nd/4.0/>).

**Key words:** whole-body reaching, arm kinematics, postural strategy, underwater, neutral buoyancy.

## INTRODUCTION

During space missions, astronauts evolve within unusual environments implying critical changes in the force field. For instance, they sustainably experience weightlessness on the International Space Station (ISS) or during Extra-Vehicular Activities (EVA), and must be ready to face other gravitational contexts such as on Moon and Mars surface for the upcoming decades of space exploration (Weiss et al., 2012). In these unusual environments, they often have to perform motor tasks in the framework of maintenance or scientific missions, requiring efficient sensorimotor behavior (see Lackner and Dizio, 2000 for a review). In order to overcome the impact of microgravity, they conventionally train underwater to learn the movements they will perform during their mission ('EVA training underwater'; Bolender et al., 2006). This training method exploits buoyancy (via the Archimedes principle) which is supposed to reduce the impact of gravity on the body by providing 'natural unweighting'. To approximate weightlessness, astronauts are immersed in training pools such that neutral buoyancy is usually applied to their Center of Mass (CoM). Neutral buoyancy is achieved when the upthrust exactly compensates for gravitational force. Despite this analogy with weightlessness, underwater exposure generates some additional viscous resistance acting on the moving limbs and does not affect vestibular signals as weightlessness does (Brown, 1961). Thus, in the field of motor control, the relevance of astronauts' underwater training remains to be further supported. To our knowledge, few studies investigated the influence of underwater exposure on sensorimotor and cognitive behavior (Brown, 1961; Ross et al., 1969; Dixon, 1985; Massion et al., 1995; Hoffmann and Chan, 2012; Dalecki and Bock, 2013, 2014; Schneider et al., 2014; Council, 2015; Schaefer et al., 2015) but none of them specifically focused on its

\*Corresponding author. Address: Institute of Movement Sciences 'Etienne-Jules Marey', UMR 7287 – CNRS & Aix-Marseille Université, Faculté des Sciences du Sport, 163, avenue de Luminy CP 910, 13288 Marseille Cedex 9, France.

E-mail address: [lionel.bringoux@univ-amu.fr](mailto:lionel.bringoux@univ-amu.fr) (L. Bringoux).

Abbreviations: ANOVAs, analyses of variances; CoM, Center of Mass; EVA, Extra-Vehicular Activities; LEDs, Light-Emitting Diodes; MD, movement duration;  $PV_{ang}$ , peak angular velocity;  $rDD_{ang}$ , relative angular deceleration duration.

direct impact on goal-directed actions. Here, we addressed this issue and specifically examined the effect of neutral buoyancy on kinematic features of whole-body reaching movements.

Unweighting the body or some of its parts and questioning its effect upon motor control has been already achieved by means of robotic systems providing adjustable levels of arm-weight support (Coscia et al., 2014) or by microgravity exposure in parabolic and space flights (Mechtcheriakov et al., 2002; Carriot et al., 2004; Papaxanthis et al., 2005; Bringoux et al., 2012). In robot-assisted rehabilitation following stroke for instance, motor improvements were often reported (Prange et al., 2006) but Coscia et al. (2014) did not find distinct kinematic features with or without gravity compensation exerted by the robot on the arm in healthy subjects. When unweighting is achieved through microgravity, some studies reported a decreased mean and peak velocity of arm displacement during reaching movements (Berger et al., 1997; Mechtcheriakov et al., 2002; Papaxanthis et al., 2005; Crevecoeur et al., 2010). Such changes in weightlessness were often associated with similar movement accuracy as compared to normogravity observations (Berger et al., 1997; Mechtcheriakov et al., 2002), although other studies reported a decrease in final accuracy (Bock et al., 1992; Fisk et al., 1993; Watt, 1997; Carriot et al., 2004; Bringoux et al., 2012). Whole-body reaching tasks implying a postural involvement in the goal-directed action also led to contradictory results when performed in microgravity. Whereas Patron et al. (2005) reported a minimization of CoM displacements as it is usually observed in normogravity, Casellato et al. (2012) observed a new postural strategy characterized by a CoM projection beyond the base of support in microgravity. These contradictory findings may actually reveal that the task requirements must be accounted for when considering the impact of unweighting on motor behavior. Furthermore, in the case of underwater exposure for EVA training, the influence of the concomitant viscous fluid resistance is often neglected. Previous work dealing with how goal-directed arm movements are performed in transient or sustained modified force fields mainly used centrifugation (Lackner and Dizio, 1994; Bourdin et al., 2001, 2006) and robot manipulandum (Shadmehr and Mussa-Ivaldi, 1994; Goodbody and Wolpert, 1998). Compared to baseline, initial impairments such as final inaccuracy, altered trajectory and slower speed were reported but these tended to vanish after exposure to the field disturbance. These results suggest that humans are able to adapt their motor behavior when facing novel environments in order to keep the goal-directed actions functional. Nevertheless, neither the effect of underwater exposure on motor control nor the description of adaptive processes in this complex environment have been documented yet.

The purpose of the present study was thus to characterize the motor behavior of humans when reaching underwater compared to reaching on land. We examined the effect of task requirements by asking subjects to reach toward close versus far targets. In our experiment, reaching toward a far target required a

whole-body displacement to successfully perform the task. This enabled us to investigate whether the postural component could serve the focal component for goal-directed actions in such unusual environments (Casellato et al., 2012). We also tested two different contexts of buoyancy since subjects were either immersed with their diving suit only (the neutral buoyancy was here only applied to the subjects CoM, but not to each body segment) or equipped with a submersible simulated space suit designed for astronauts training named ‘Gandolfi’<sup>†</sup> (Hornet et al., 1990; Weiss et al., 2012). This unique space suit enabled the application of neutral buoyancy across body limbs and the adjustment of joint stiffness similar to that exerted in a pressurized space suit. Based on previous work, we expected underwater exposure to influence motor behavior but also expected this influence to vary with the experimental manipulation of buoyancy. Furthermore, we also hypothesized that target location (i.e., close versus far which determines the degree of postural involvement) could be critical in the way underwater exposure and buoyancy may affect whole-body reaching.

## EXPERIMENTAL PROCEDURES

### Participants

Eight right-handed professional divers (three women and five men, 1B-diving certificate holders, mean age =  $38 \pm 7.9$  years) participated in the experiment on a voluntary basis. Security constraints excluded the possibility of testing naive participants in this environment. None of the subjects suffered from neuromuscular or sensory impairments. Vision was normal or corrected by lenses. All subjects were naive as to the specific purpose of the experiment, which was approved by the institutional review board of the Institute of Movement Sciences. They gave their signed informed consent prior to the study in accordance with the Helsinki Convention.

### Experimental setup

Subjects stood upright in front of two targets, with their feet attached to the ground structure by means of footstraps (Fig. 1A). They had to press their right index finger on the start push-button positioned alongside. The height of the push-button was adjusted to each subject’s height for initial posture standardization. Two circular targets (diameter: 10 cm) were presented to the subjects. They were oriented along the frontal plane and were positioned relative to subjects’ anthropometric features. The close target was positioned at shoulder’s height (i.e., the height of the target center corresponded to the horizontal projection of the height of the acromioclavicular joint in the sagittal plane) at a distance corresponding to arm length, allowing the subjects to reach this target without trunk displacement. The far target was positioned 25 cm away and 20 cm below the close target: in that case, subjects had to make an additional trunk displacement to reach this

<sup>†</sup> Developed by COMEX S.A. & DASSAULT companies.

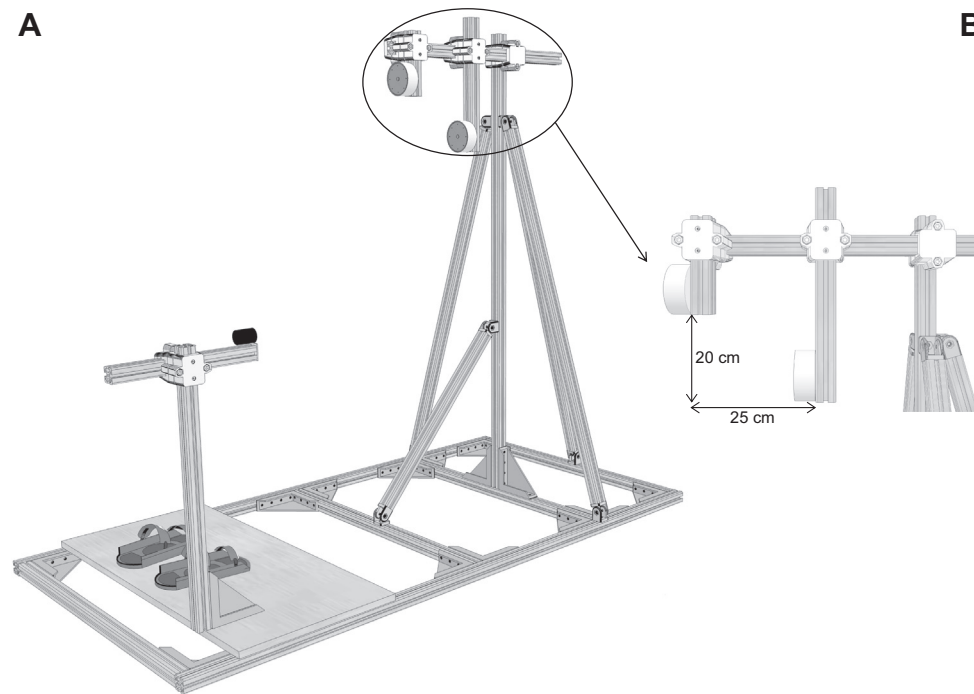

**Fig. 1.** Experimental setup. (A) Global view of the pointing structure including targets, start push-button (black array) and footstraps. (B) Side view of the targets which illustrates the position of the far target relative to the close target.

target (Fig. 1B). Each target could be illuminated through watertight Light-Emitting Diodes (LEDs) equally distributed around the border. Target switching and extinction were achieved by using a homemade software (Docometre©) piloting a real-time acquisition/control system running at 10 kHz (ADwin-Gold©, Jäger, Lorsch, Germany).

Luminescent markers (LED-type) were positioned onto the subjects' index, shoulder and hip. Markers position was recorded by a video motion capture system composed of three cameras sampled at 60 Hz (resolution:  $848 \times 480$  pixels). These cameras were inserted in custom-made watertight housing for underwater acquisition.

### Procedure

All the subjects were exposed to three environments: 1/on land ("Land"), 2/underwater with neutral buoyancy applied to the CoM only ("Aqua"), 3/underwater with neutral buoyancy applied to body limbs by using a "Submersible Simulated Space Suit" ("AquaS"). In these three environments, subjects wore their diving suit to neutralize the effects of joint stiffness proper to the suit. Underwater conditions were performed in a specially-equipped pool (4 m deep) at COMEX SA. In Aqua, subjects wore their diving mask, air tank and wet suit with a weight belt, such that free floating was reached, but without specific control of buoyancy across the body segments. Conversely in AquaS, subjects also wore their diving mask and air tank, but were additionally equipped with the submersible simulated space suit ("Gandolfi") enabling us to apply neutral buoyancy across the body limbs. These buoyancy features were

achieved by means of floats and weights specifically distributed into the simulated space suit to cancel out the gravitational force on each body part. Additionally, joint stiffness was tuned by means of adjustable springs to counteract the resultant torques yielded by the exoskeleton underwater (i.e. to minimize the influence of additional stiffness/inertia due to the exoskeleton upon motor output and subsequent kinematics). Subjects first performed the Land condition and four months later both underwater conditions whose order was counterbalanced.

Positions of the start push-button and the targets were adjusted for each subject before performing a calibration along the Z vertical axis (corresponding to arm movement elevation). Before each trial, subjects had to stand upright, the arms outstretched along the body, and the right index pressing on the start push-button. When one of the targets was illuminated, subjects were asked to perform an arm reaching movement toward the target while keeping the arm outstretched. Reaching movements had to be performed as quickly as possible while primarily respecting accuracy constraints related to the target area. The trial was validated when the index fingertip reached the target. The final position had to be maintained until target extinction (3 s after movement onset) which prompted the subjects to return to the starting position.

Subjects performed 42 pointing movements toward each of the two targets for a total of 84 trials per experimental session (during which the subjects were exposed to one of the three specific environments). The two targets were presented in a pseudorandom order, which was counterbalanced between the subjects. Each session included three specific blocks of four trials in



which the order of target presentation was the same. These blocks were presented in the initial, middle and final part of the session to easily assess the potential evolution of motor performance in each session, which lasted about 45 min.

### Data processing

For each trial, the time elapsed between target illumination and the release of the start push-button by the subjects defined the reaction time (RT). Video data from the three cameras were initially synchronized and sequenced (Kinovea© software), subsequently allowing for the appropriate tracking of the selected markers (i.e., XZ coordinates over time for index, shoulder and hip position). A 3D reconstruction method (Direct Linear Transformation; Abdel-Aziz and Karara, 1971) was used to merge XZ coordinates of a same marker from each camera (Labview™ software). This 3D reconstruction method enabled us to improve the accuracy of markers' position estimates to  $3.3 \times 10^{-3} \pm 4 \times 10^{-3}$  m on average. Kinematic data presented below were obtained from this video processing and concerned the movement features in the sagittal plane.

First, we analyzed the fingertip trajectory, success rate, final accuracy, RT, movement duration (MD) and mean tangential velocity ( $V_{\text{mean}_{\text{endpoint}}}$ ). The final accuracy was measured as the absolute error, i.e., the mean unsigned distance of the final position of the index fingertip relative to the target center along the Z vertical axis. Index position in the sagittal plane was filtered (digital second-order dual-pass Butterworth filter; 6 Hz cutoff frequency) and differentiated to obtain the endpoint tangential velocity in  $\text{m}\cdot\text{s}^{-1}$ . The movement onset was defined as the time when the index tangential velocity reached 1.5% of its peak. Conversely, movement end was defined when the tangential velocity dropped below 1.5% of its peak. Compared to higher cutoff values (5% of peak velocity) reported in other studies performed on land or in microgravity (Papaxanthis et al., 2005; Gentili et al., 2007; Gaveau and Papaxanthis, 2011; Bringoux et al., 2012), this threshold was chosen to avoid underestimation of movement duration considering the task constraints and their behavioral consequences underwater (e.g., slower velocity).

In this study, subjects performed reaching movements characterized by a single-joint arm elevation around the shoulder (i.e., with the arm outstretched). We therefore analyzed the focal component of whole-body reaching movements by considering the arm angular elevation over time (i.e., angle evolution of the extended arm relative to the shoulder with respect to its initial orientation). Arm angular elevation was computed from the index and shoulder XZ raw data, filtered (digital second-order dual-pass Butterworth filter; 6 Hz cutoff frequency) and differentiated to obtain angular velocity. From this, peak velocity ( $PV_{\text{ang}}$  in  $\text{deg}\cdot\text{s}^{-1}$ ) and the relative angular deceleration duration ( $rDD_{\text{ang}}$ , defined as the duration between  $PV_{\text{ang}}$  and movement end, in % of movement duration) were extracted.

In parallel, the postural component involved in the whole-body reaching movements (especially to reach the far target) was analyzed by considering trunk displacement. This latter was illustrated by the final angular position of trunk (hip-shoulder segment) relative to vertical ( $\beta_{\text{trunk}}$ : trunk flexion in deg) at arm movement end, and by the forward displacement of subjects' shoulder and hip (translation in mm). Shoulder and hip movement onset/end were defined as the time when the translational velocity on the X axis respectively reached/dropped below 1.5% of its peak.

Statistical analyzes were based on mean comparisons. Repeated-measures analyses of variances (ANOVAs) were performed to compare the means of kinematic parameters mentioned above after having ensured that the assumption of normality and homogeneity of variance were not violated (Kolmogorov–Smirnov and Levene tests). Newman–Keuls tests were used for post hoc analyses and the significance threshold was set at .05 for all statistical tests.

## RESULTS

### Potential learning effects

Preliminary analyses investigated potential adaptive processes which might have been at work during a single session (84 trials). Repeated-measures ANOVAs including three Environment (Land, Aqua, AquaS)  $\times$  2 Target Position (Close, Far)  $\times$  3 Block (Initial, Middle, Final) were initially performed on all the selected parameters. The results did not show any significant main effect of Block or any interaction with the other factors ( $p > .05$ ). Thus, the reported variables did not significantly change along a session depending on the moment of occurrence for a specific set of target presentation (see Experimental procedures). For the sake of clarity and statistical robustness, we thus removed the Block factor from our subsequent analyses.

### Upper-limb displacement

We first examined arm displacement toward the targets in each environment. Fig. 2A illustrates endpoint trajectories (i.e., index fingertip) in the sagittal plane observed for a typical subject. It shows that final accuracy was comparable across conditions but that spatio-temporal characteristics of endpoint motion were impacted by the experimental conditions.

*Success rate and final accuracy.* Subjects never missed any targets (Close or Far), resulting in a 100% success rate in each experimental condition. Moreover, the ANOVA performed on the final accuracy (mean =  $7.79 \pm 3.65$  mm) yielded no significant main effects (Environment:  $p = .11$ ; Target Position:  $p = .23$ ) and no interaction between these two factors ( $p = .19$ ).

*Reaction time (RT).* The ANOVA performed on RT revealed a significant main effect of Environment ( $F(2,14) = 12.60$ ;  $p < .001$ ). Post-hoc analysis showed

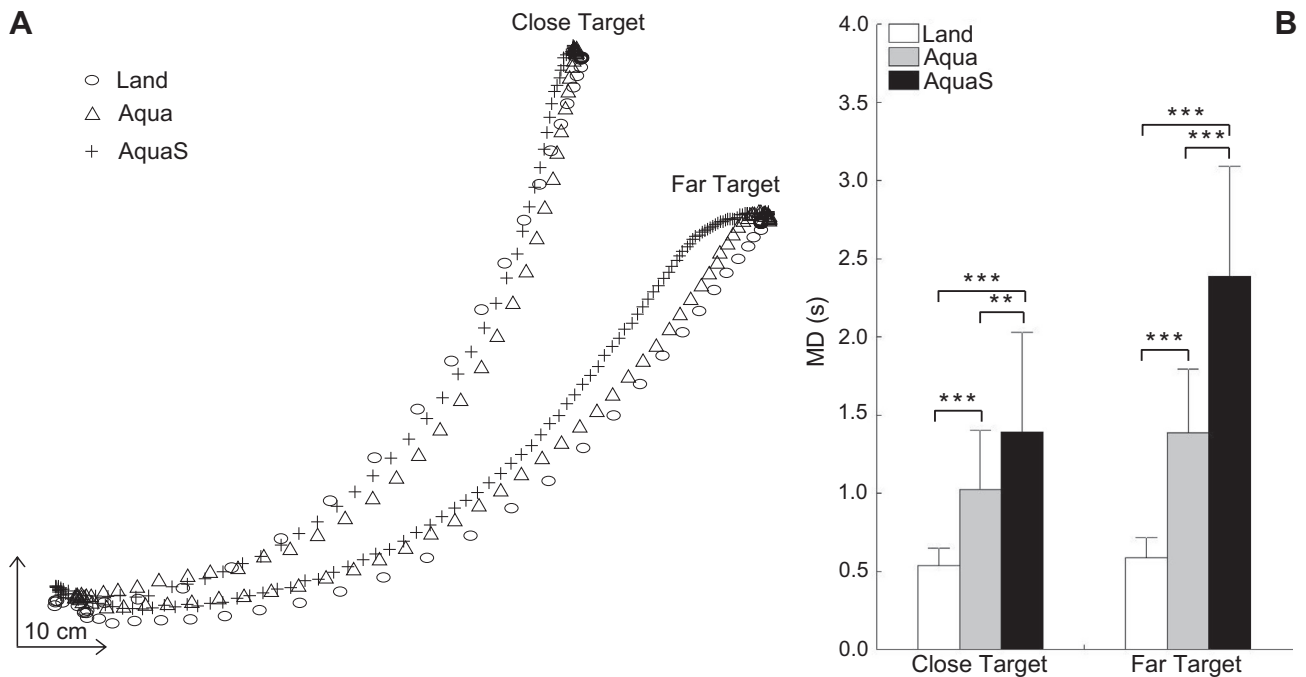

**Fig. 2.** (A) Representative endpoint trajectories for a typical subject in Land (circle), Aqua (triangle) and AquaS (cross) for the Close and Far targets. (B) Mean duration of endpoint movement as a function of Environment and Target Position. Error bars represent standard deviation of the mean. \*\*\* $p < .001$ ; \*\* $p < .01$ .

more specifically that RT in Land (mean =  $313 \pm 34$  ms) was shorter than in Aqua (mean =  $444 \pm 138$  ms;  $p < .01$ ) and AquaS (mean =  $495 \pm 115$  ms;  $p < .001$ ), while no significant difference was found between Aqua and AquaS regarding this variable ( $p = .19$ ). No other significant main effect or interaction was found with regard to Target Position.

**Movement duration (MD) and mean tangential velocity ( $V_{\text{mean}_{\text{endpoint}}}$ ).** The ANOVA conducted on MD yielded significant main effects of Environment ( $F(2,14) = 28.05$ ;  $p < .001$ ) and Target Position ( $F(1,7) = 165.25$ ;  $p < .001$ ) as well as a significant interaction between these two factors ( $F(2,14) = 33.65$ ;  $p < .001$ ; Fig. 2B). While MD in Land was shorter than in Aqua ( $p < .001$ ) and AquaS ( $p < .001$ ) for both Close and Far targets, MD in AquaS was even longer than in Aqua for the Far target ( $p < .001$ ) as compared to the Close target ( $p < .01$ ).

The ANOVA conducted on  $V_{\text{mean}_{\text{endpoint}}}$  revealed a significant main effect of Environment ( $F(2,14) = 105.57$ ;  $p < .001$ ). Post hoc analyses showed that the mean tangential velocity differed in each of the three environments (mean =  $1.94 \text{ m s}^{-1}$ ,  $0.98 \text{ m s}^{-1}$ , and  $0.64 \text{ m s}^{-1}$ , for Land, Aqua and AquaS respectively;  $p < .01$ ). The analysis also showed a main effect of Target Position (Far target:  $1.06 \text{ m s}^{-1}$  vs. Close target:  $1.31 \text{ m s}^{-1}$ ;  $F(1,7) = 28.03$ ;  $p < .01$ ). No significant interaction was found between these two factors.

Thus, our experimental conditions did influence the temporal execution of endpoint displacement during whole-body reaching movements. Next, we investigated the relative spatiotemporal organization of the focal

component illustrated by the arm angular elevation over time.

**Peak angular velocity ( $PV_{\text{ang}}$ ) and relative angular deceleration duration ( $rDD_{\text{ang}}$ ).** Fig. 3A illustrates arm angular velocity profiles for both Close and Far targets in each environment. It shows that the experimental conditions appeared to impact the amplitude and the temporal structure of the velocity profiles. These modulations were well reflected by the analysis of  $PV_{\text{ang}}$  and  $rDD_{\text{ang}}$ .

The ANOVA conducted on  $PV_{\text{ang}}$  revealed significant main effects of Environment ( $F(2,14) = 53.19$ ;  $p < .001$ ) and Target Position ( $F(1,7) = 28.14$ ;  $p < .01$ ), as well as a significant interaction between both factors ( $F(2,14) = 7.64$ ;  $p < .01$ ; Fig. 3B). While  $PV_{\text{ang}}$  in Land was higher than in Aqua ( $p < .001$ ) and AquaS ( $p < .001$ ) for both Close and Far targets,  $PV_{\text{ang}}$  in AquaS was even lower than in Aqua for the Far target ( $p < .001$ ) as compared to the Close target ( $p < .01$ ).

The ANOVA performed on  $rDD_{\text{ang}}$  revealed significant main effects of Environment ( $F(2,14) = 4.78$ ;  $p < .05$ ) and Target Position ( $F(1,7) = 19.06$ ;  $p < .01$ ) as well as a significant interaction between these two factors ( $F(2,14) = 6.10$ ;  $p < .05$ ; Fig. 3C). For the Close target,  $rDD_{\text{ang}}$  was lower in Land than in Aqua ( $p < .05$ ) and AquaS ( $p < .05$ ), but did not significantly differ in the two latter environments ( $p = .32$ ). Conversely for the Far target,  $rDD_{\text{ang}}$  in Land was lower than in AquaS ( $p < .001$ ), but did not significantly differ from Aqua ( $p = .13$ ). Most importantly,  $rDD_{\text{ang}}$  in AquaS was significantly higher than in Aqua ( $p < .01$ ).

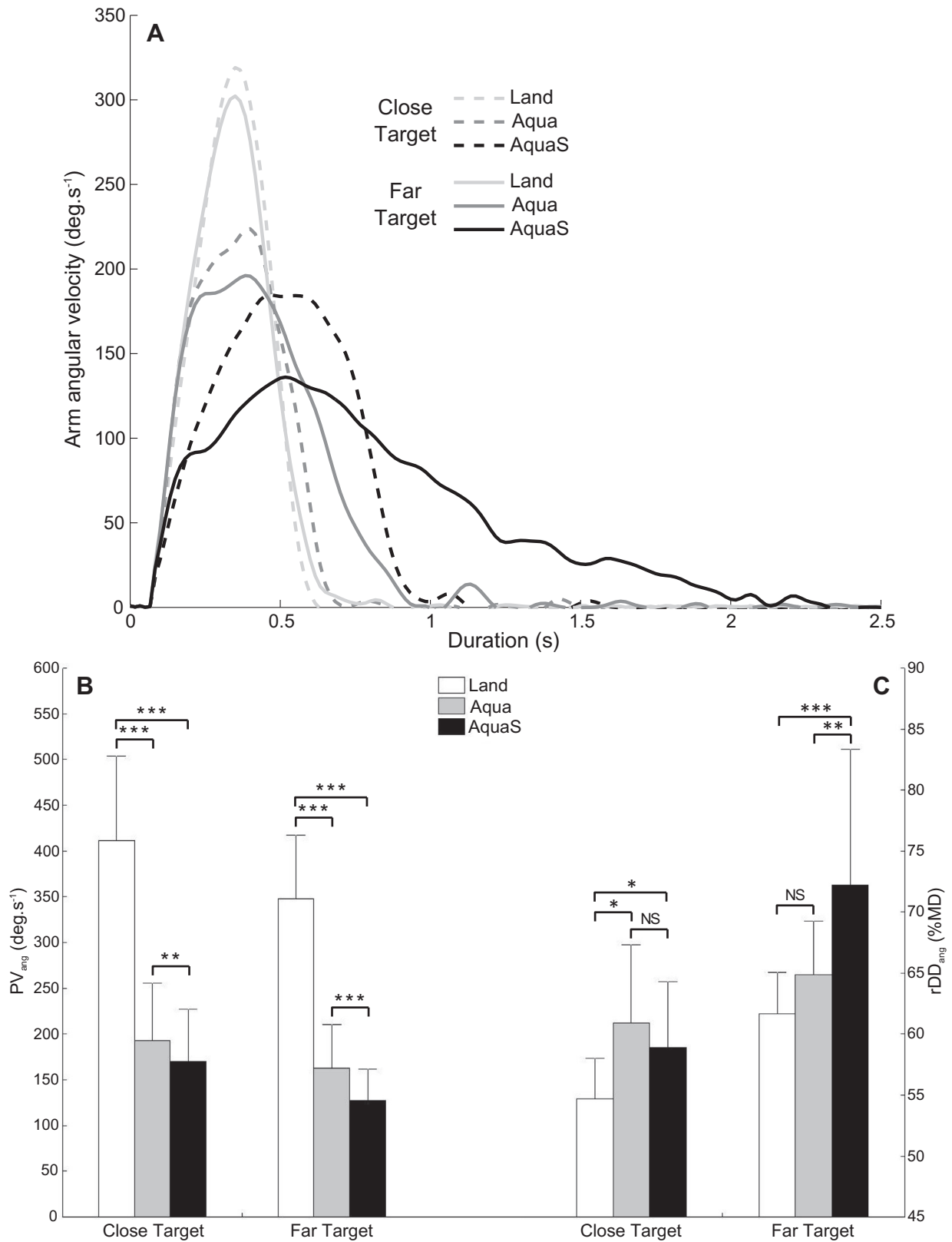

**Fig. 3.** (A) Representative arm angular velocity profiles for a typical subject in Land (light gray), Aqua (dark gray) and AquaS (black) for the Close and Far targets. (B) Mean arm angular peak velocity (PV) and (C) Mean relative angular deceleration duration (rDD<sub>ang</sub>) as a function of Environment and Target Position. Error bars represent standard deviation of the mean. \*\*\**p* < .001; \*\**p* < .01; \**p* < .05; NS: non-significant difference.

Thus, the arm angular elevation reached slower maximal velocities underwater. This effect was accentuated when the neutral buoyancy was applied to body limbs by means of a simulated space suit as compared to when it was applied to the CoM only. In this former underwater condition (AquaS), the relative deceleration duration of arm angular elevation was substantially increased when reaching the Far target, when compared to both Land and Aqua conditions. The next part will focus on the postural component involved in whole-body reaching, especially when reaching the Far target.

### Trunk displacement

*Final angular position of trunk relative to vertical ( $\beta_{trunk}$ ).* The ANOVA performed on  $\beta_{trunk}$  revealed main effects of Environment ( $F(2,14) = 6.77$ ;  $p < .01$ ) and Target Position ( $F(1,7) = 470.72$ ;  $p < .001$ ). Moreover, the analysis yielded a significant interaction between these two factors ( $F(2,14) = 37.68$ ;  $p < .001$ ; Fig. 4). While no significant difference appeared between the three environments when reaching toward the Close target ( $p > .05$ ), mean  $\beta_{trunk}$  when reaching toward the Far target was significantly lower in AquaS as compared to Land ( $p < .001$ ) and Aqua ( $p < .001$ ), while no difference was found between these two latter environments ( $p = .51$ ).

*Shoulder and hip forward displacements.* Unsurprisingly, no noticeable forward translation was observed for shoulder and hip when reaching toward the Close target (located at subjects arm length, see Methods). Although small movements of both joints were recorded during reaching execution, they were below the threshold we used for determining the start and end of a translational displacement. Therefore, we subsequently focused our analysis on the shoulder and hip forward displacements occurring when reaching toward the Far target.

The ANOVA conducted on shoulder displacement yielded a significant main effect of Environment ( $F(2,14) = 6.79$ ;  $p < .01$ ). Post hoc analyses showed that the shoulder displacement in AquaS (mean = 361 mm) was significantly higher than in Land (mean = 301 mm;  $p < .01$ ) and Aqua (mean = 282 mm;  $p < .05$ ) while no significant difference was found between these latter conditions ( $p = .41$ ). Similarly, the ANOVA performed on hip displacement revealed a significant main effect of Environment ( $F(2,14) = 34.49$ ;  $p < .001$ ). Post hoc analyses showed that the hip displacement in AquaS (mean = 331 mm) was significantly higher than in Land (mean = 31 mm;  $p < .001$ ) and Aqua (mean: 27 mm;  $p < .001$ ) while no significant difference was found between these latter conditions ( $p = .92$ ).

Overall, these analyses indicate that the postural involvement differed during whole-body reaching movements as a function of the Environment and Target Position. When neutral buoyancy was applied across the limbs underwater by means of a simulated space suit, reaching toward far targets led to smaller trunk bending associated to larger forward displacements of

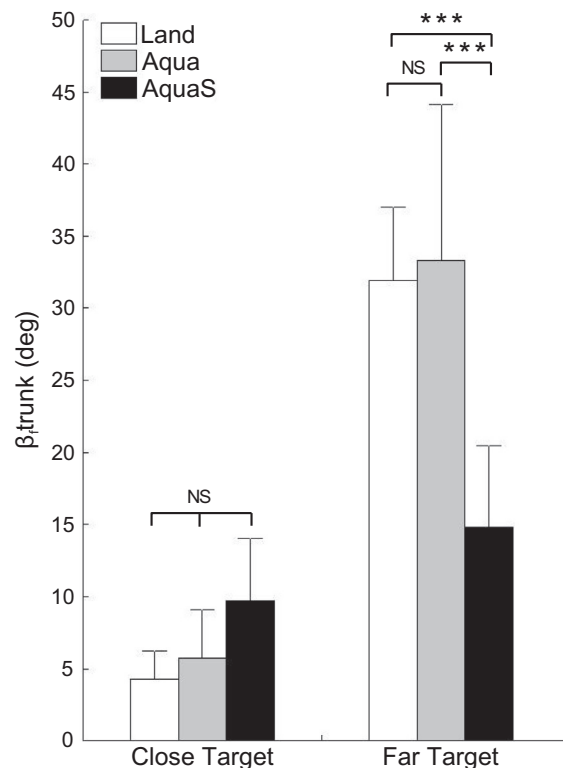

**Fig. 4.** Mean final angular position of trunk relative to the vertical as a function of Environment and Target Position. Error bars represent standard deviation of the mean. \*\*\*  $p < .001$ ; NS: non-significant difference.

the shoulder and hip, as compared to land and underwater exposure without specific control of buoyancy across the body segments. The following discussion will address the main focal and postural differences previously reported and will propose possible interpretations for these observations.

## DISCUSSION

In this study, we investigated the influence of underwater exposure on motor behavior by testing subjects' performance in a whole-body reaching task, compared to a standard land condition. We also questioned the influence of neutral buoyancy and its specific application to body segments, as enabled by the use of a submersible simulated space suit. Analysis of the spatiotemporal characteristics of whole-body reaching movements demonstrated how underwater exposure by itself impacts basic movement features, especially in terms of speed reduction. However, movement kinematics also differed according to the way buoyancy was exerted across body limbs. Remarkably, some parameters reflecting the organization of focal and postural components of whole-body reaching were close to Land observations when neutral buoyancy was not specifically applied to each limb underwater (Aqua condition). Conversely, when subjects were equipped with the submersible simulated space suit, in which neutral buoyancy was exerted across the body



segments (AquaS condition), substantial reorganizations of focal and postural components of the movement were found, resembling those reported in microgravity.

### **Basic influence of underwater exposure on motor behavior**

Remarkably, we did not find any significant changes in the reported variables across the successive reaching movements performed underwater, thus suggesting the absence of any significant adaptation taking place during the experiment. Rather, we observed some motor reorganizations which took place at the earliest onset of exposure in Aqua and AquaS. Several hypotheses can be advanced to explain this observation. First, it is possible that the task constraints were not sufficient to yield adaptation along the experiment. Indeed, the subjects immediately succeeded in reaching the intended targets whatever the environment, thus implying no need to change the initial –successful– behavior. Moreover, the participants were all professional divers used to work and move underwater. The amount of experience gained by divers underwater could have been thus detrimental to the occurrence of adaptive effects in the study. However, it must be reminded that none of them had any experience with the submersible simulated space suit. In this latter condition, we could then argue that either the movements performed by the subjects during their installation on the pointing structure or prior expectancies of what it could be to move in a submersible suit favored motor pre-settings for immediate reorganization.

Overall, the substantial decrease of movement speed constitutes the most salient feature of motor reorganization underwater. This was reflected by higher movement duration and lower mean and peak velocity during movement execution, as compared to Land observations. These findings, observed both in Aqua and AquaS, are most likely related to the viscous resistance of the fluid during movement execution (Hoffmann and Chan, 2012). However, we cannot exclude that slowing down could reflect a *pre-established* strategy to face the anticipated disturbances underwater in order to maintain a given level of performance. Following this, the decrease in movement speed could be viewed as a natural response to the increase of task difficulty (i.e., to an unusual force field), according to Fitts' law (Fitts, 1954; Kerr, 1973, 1978). This hypothesis is supported by higher reaction times in Aqua and AquaS, thus suggesting that not only movement execution but also motor planning is modified underwater. This is consistent with a previous study also reporting an increase of reaction time during discrete reaching movements similar to Fitts' task performed in a pool (Dixon, 1985). As mentioned earlier, movement speed reduction, whether it could partly arise from an active reorganization in motor planning at the CNS level or from water resistance, could aim at keeping some aspects of motor performance unaffected. In this regard, we noticed a maximal success rate (100%) and similar final accuracy in Land, Aqua and AquaS. As requested, the subjects have thus favored the spatial constraints of the task, even when facing unusual environments. Interestingly, as we

will detail in the following part, keeping this high level of accuracy underwater implied more subtle changes in motor behavior, depending on the way buoyancy is applied across the body and the Target Position to be reached.

### **Underwater motor features when neutral buoyancy is not specifically applied to body limbs**

When participants wore only their diving suit with a weight belt and reached toward the far target, the relative length of deceleration phase of arm angular elevation as well as the final trunk flexion were close to those recorded on land. In other words, the motor behavior exhibited in Aqua may also reflect some spatiotemporal characteristics observed on land when considering the focal and postural components of whole-body reaching.

With regard to the focal component, arm elevation exhibited asymmetric bell-shaped velocity profiles (i.e., the relative deceleration duration of upward arm movements being longer than the relative acceleration duration), in line with previous reports on land (Gentili et al., 2007; Gaveau and Papaxanthis, 2011). Interestingly, while this asymmetry increased in Aqua with respect to Land when reaching toward the close target, it did not differ between these two conditions when reaching toward the far target. In other words, as soon as a postural motion was necessary to perform the whole-body reaching task, the relative spatiotemporal organization of the focal kinematics was comparable between Land and Aqua.

With regard to the postural component involved during whole-body reaching, one may hypothesize that a common postural strategy was used in Land and Aqua, which consisted in bending the trunk forward to assist the focal part of the movement (Massion, 1992; Vernazza et al., 1999). Such a posturo-kinetic strategy was also illustrated in our study by a large forward displacement of the shoulder associated to a very small displacement of the hip to reach the far target, both in Land and Aqua. This would favor equilibrium maintenance at the cost of mechanical energy minimization (i.e., higher absolute work) and joint smoothness maximization (i.e., higher angular jerk). In line with the optimal control theory, the combination of these cost functions (energy/smoothness) has been previously shown to characterize the control of reaching in sitting (Berret et al., 2011) and standing postures (Hilt et al., 2016) on land. The replication of this “on land-strategy” underwater, when neutral buoyancy is not specifically applied to body limbs, is also consistent with a study conducted by Massion et al. (1995) who reported a persistence of the terrestrial postural control during movements involving trunk flexion underwater. However, as discussed below, this strategy did not persist underwater when neutral buoyancy was applied across the body segments.

### **Motor reorganizations associated with distributed neutral buoyancy across body limbs**

When neutral buoyancy was applied at the level of each body segment by means of a unique submersible

simulated space suit, substantial motor reorganizations were noticed regarding focal kinematics and postural strategy. First, arm elevation in AquaS was characterized by a longer relative deceleration phase as compared to Land and Aqua. Neutral buoyancy homogeneously applied to the whole-body segments substantially changed the force field as compared to “raw” underwater exposure with the diving suit only. In AquaS, the use of pre-established internal models for sensorimotor planning and execution, acquired on Earth from past experience, may have become irrelevant (Wolpert and Kawato, 1998; Wolpert and Ghahramani, 2000). Also, to be activated, these representations strongly depend on the initial state of the sensorimotor system which provides useful information to elaborate the upcoming motor plan (Starkes et al., 2002; Flanagan et al., 2006; White et al., 2012). Here, the distributed neutral buoyancy in AquaS deeply modified the effect of gravitational force acting on upper limb joints. Several studies demonstrated that gravity is integrated in motor planning and anticipated in terms of expected sensory states (Berret et al., 2008; Crevecoeur et al., 2009; Gaveau et al., 2011, 2014). We therefore suggest that in AquaS, the uncertainty regarding these novel environmental constraints could disrupt the use of predictive mechanisms based on initial state estimates, as the latter could not be related to any previous experience. Accordingly, this would lead to a greater use of feedback processes (Bringoux et al., 2012; Franklin et al., 2012). Supporting this hypothesis, we found lower peak velocity and increased relative deceleration duration in AquaS, which would allow more time for sensory feedback control (Chua and Elliott, 1993; Sarlegna et al., 2003; Terrier et al., 2011). Thus, as feedforward predictions could be insufficient or incorrect in this context, the upregulation of feedback gains could help dealing with the unexpected disturbances and maintain movement accuracy (Franklin et al., 2012).

A second main finding relates to the postural reorganization observed in AquaS. Subjects seemed to adopt a new postural strategy illustrated in our study by a smaller trunk flexion than in Land and Aqua to reach the far target. This smaller trunk flexion suggests a whole-body forward displacement which would correspond to the ankle strategy evoked by Nashner and McCollum (1985), though with greater amplitude. In our study, this is supported by larger hip and shoulder forward displacements in AquaS than in Land and Aqua (while no significant difference was observed between these latter conditions). Such a strategy may help reducing the degrees of freedom (Bernstein, 1967) by minimizing the number of ‘free-to-move’ joints. Moreover, it could also minimize the mechanical energy expenditure and maximize joint smoothness, in line with the optimal control theory (Berret et al., 2011). The combination of these cost functions would thus enable the postural component to support more efficiently the focal part of the reaching movement. According to Hilt et al. (2016), a postural strategy based on whole-body forward displacement reduces the equilibrium safety margin in land. In AquaS however, the neutral buoyancy applied across the whole-body

seems to decrease the gravitational constraints and the risk of falling, even when the CoM projection was presumably outside the base of support. Therefore, the postural strategy specifically used in this condition may reflect the interactions between cost functions which led to a tradeoff between efficient reaching and equilibrium maintenance (Hilt et al., 2016).

### **Behavioral similarities between AquaS and microgravity: a perspective of motor transfer?**

As compared to Land observations, underwater exposure resulted in a decrease of movement speed which appears to be greater than that usually reported in weightlessness (Berger et al., 1997; Papaxanthis et al., 2005). This observation may be mainly explained by the additional presence of fluid resistance underwater (Hoffmann and Chan, 2012). However, when focusing on the kinematics of arm elevation normalized with respect to movement duration, similar reorganizations could be pointed out between AquaS and microgravity. Indeed, we previously reported an increase of the normalized deceleration phase of arm elevation in microgravity comparable to that observed here in AquaS (Bringoux et al., 2012). This longer relative deceleration phase would allow for a greater use of feedback corrective processes to compensate for incorrect initial state estimates prior to movement onset. Indeed, the simulation of a gravity-like shoulder torque in weightlessness, by means of elastic bands attached to the forearm, has been found to provide sufficient prior information to reactivate gravity-related internal models and thus restore kinematics and final accuracy of arm reaching (Bringoux et al., 2012).

Casellato et al. (2012) observed that when reaching movements required trunk mobilization in microgravity (whole-body reaching), subjects adopted a new postural strategy illustrated by a whole-body forward displacement toward the target, as in the present study. In Casellato et al. (2012) study, a biomechanical model revealed that this strategy was based on a CoM projection beyond the base of support. Notably, the subjects were not constrained by the gravitational force which would impose a reduction of the displacement of the CoM projection by some compensatory mechanisms. These main postural features led Casellato et al. (2012) to suggest the existence of an “oversimplification” of postural control to perform reaching movements. This would favor the fine control of the focal component during whole-body reaching, ensuring its final accuracy despite the degraded initial state estimates. We here postulate that similar processes were operating underwater when the subjects were immersed in the simulated space suit (AquaS).

The behavioral similarities that could be reported between AquaS and the microgravity environment strongly suggest that the neutral buoyancy, when uniformly exerted across the whole-body, could help reproducing a microgravity-like environment, despite the presence of additional fluid resistance. In the framework of astronauts’ training, it could be of value to test whether motor skills learned in this particular immersive environment could be transferred and used during

extra-vehicular activities in space. Likely, a fine control of buoyancy across the whole-body may be advantageous to underwater training methods, by providing a more realistic EVA environment. Most importantly, the motor reorganizations observed in AquaS were observed at the early stage of exposure to the novel environmental constraints, and thus may not require adaptive processes to become functional. The occurrence of such early functional motor reorganizations must however be challenged in tasks involving higher accuracy constraints and tested with less experienced divers.

## CONCLUSION

Although underwater exposure by itself influences some basic features of motor behavior during arm reaching movements as compared to land observations, the present study shows that some focal and postural components of the motor output underwater remain close to standard normogravity behavior when neutral buoyancy is not exerted across whole-body segments. On the contrary, when neutral buoyancy is applied to each body limb, by means of a submersible simulated space suit, subjects tend to produce focal and postural kinematics close to those observed in weightlessness. In other words, the fine control of neutral buoyancy, may improve the quality of the simulation of microgravity environments, thus optimizing astronauts' training before space missions.

*Acknowledgments*—The authors are grateful to COMEX S.A. for the fruitful partnership, in particular to B. Gardette and M. Fructus. We also wish to thank J.-F. Bramard and CAMBULLE Company for technical expertise in video acquisition.

This work benefited from Research Grants (DAR 2013-2015) from the French National Centre for Space Studies (CNES).

## REFERENCES

- Abdel-Aziz YI, Karara HM (1971) Direct linear transformation from comparator coordinates into object space coordinates. *Am Soc Photogramm* 40:1–18.
- Berger M, Mescheriakov S, Molokanova E, Lechner SS, Seguer N, Kozlovskaya I (1997) Pointing arm movements in short- and long-term spaceflights. *Aviat Space Environ Med* 68:781–787.
- Bernstein NA (1967) *The co-ordination and regulation of movements*. Oxford: Pergamon Press.
- Berret B, Darlot C, Jean F, Pozzo T, Papaxanthis C, Gauthier JP (2008) The inactivation principle: mathematical solutions minimizing the absolute work and biological implications for the planning of arm movements. *PLoS Comput Biol* 4(10):e1000194.
- Berret B, Chiovetto E, Nori F, Pozzo T (2011) Evidence for composite cost functions in arm movement planning: an inverse optimal control approach. *PLoS Comput Biol* 7(10):e1002183.
- Bock O, Howard IP, Money KE, Arnold KE (1992) Accuracy of aimed arm movements in changed gravity. *Aviat Space Environ Med* 63:994–998.
- Bolender H, Stevenin H, Bessone L, Torres A (2006) Preparing for space. EVA training at the European Astronaut Centre. *ESA Bull* 128:32–40.
- Bourdin C, Gauthier GM, Blouin J, Vercher J-L (2001) Visual feedback of the moving arm allows complete adaptation of pointing movements to centrifugal and Coriolis forces. *Neurosci Lett* 301:25–28.
- Bourdin C, Bringoux L, Gauthier GM, Vercher J-L (2006) Vision of the hand prior to movement onset allows full motor adaptation to a multi-force environment. *Brain Res Bull* 71:101–110.
- Bringoux L, Blouin J, Coyle T, Ruget H, Mouchnino L (2012) Effect of gravity like torque on goal-directed arm movements in microgravity. *J Neurophysiol* 107:2541–2548.
- Brown JL (1961) Orientation to the vertical during water immersion. *Aerosp Med* 32:209–217.
- Carriot J, Bringoux L, Charles C, Mars F, Nougier V, Cian C (2004) Perceived body orientation in microgravity: effects of prior experience and pressure under the feet. *Aviat Space Environ Med* 75:795–799.
- Casellato C, Tagliabue M, Pedrocchi A, Papaxanthis C, Ferrigno G, Pozzo T (2012) Reaching while standing in microgravity: a new postural solution to oversimplify movement control. *Exp Brain Res* 216:203–215.
- Chua R, Elliott D (1993) Visual regulation of manual aiming. *Hum Mov Sci* 12:365–401.
- Coscia M, Cheung VC, Tropea P, Koenig A, Monaco V, Bennis C, Micera S, Bonato P (2014) The effect of arm weight support on upper limb muscle synergies during reaching movements. *J Neuroeng Rehab* 11:22.
- Council L (2015) Field dependence and orientation of upside-down posture in water. *Percept Mot Skills* 120:15–24.
- Crevecoeur F, Thonnard J-L, Lefèvre P (2009) Optimal integration in trajectory planning of vertical pointing movements. *J Neurophysiol* 102:786–796.
- Crevecoeur F, McIntyre J, Thonnard J-L, Lefèvre P (2010) Movement stability under uncertain internal models of dynamics. *Neurophysiology* 104:1301–1313.
- Dalecki M, Bock O (2013) Changed joint position sense and muscle activity in simulated weightlessness by water immersion. *Aviat Space Environ Med* 84:110–115.
- Dalecki M, Bock O (2014) Isometric force exaggeration in simulated weightlessness by water immersion: role of visual feedback. *Aviat Space Environ Med* 85:605–611.
- Dixon DJ (1985), *Underwater movement and Fitts' law*. PhD dissertation in Psychology, Texas Tech University.
- Fisk J, Lackner JR, DiZio P (1993) Gravitoinertial force level influences arm movement control. *J Neurophysiol* 69:504–511.
- Fitts PM (1954) The information capacity of the human motor system in controlling the amplitude of movement. *J Exp Psychol* 47:381–391.
- Flanagan JR, Bowman MC, Johansson RS (2006) Control strategies in object manipulation tasks. *Curr Opin Neurobiol* 16:650–659.
- Franklin S, Wolpert DM, Franklin DW (2012) Visuomotor feedback gains upregulate during the learning of novel dynamics. *J Neurophysiol* 108:467–478.
- Gaveau J, Papaxanthis C (2011) The temporal structure of vertical arm movements. *PLoS One* 6(7):e22045.
- Gaveau J, Paizis C, Berret B, Pozzo T, Papaxanthis C (2011) Sensorimotor adaptation of point-to-point arm movements after spaceflight: the role of internal representation of gravity force in trajectory planning. *J Neurophysiol* 106:620–629.
- Gaveau J, Berret B, Demougeot L, Fadiga L, Pozzo T, Papaxanthis C (2014) Energy-related optimal control accounts for gravitational load: comparing shoulder, elbow, and wrist rotations. *J Neurophysiol* 111:4–16.
- Gentili RJ, Cahouet V, Papaxanthis C (2007) Motor planning of arm movements is direction-dependent in the gravity field. *Neuroscience* 145:20–32.
- Goodbody SJ, Wolpert DM (1998) Temporal and amplitude generalization in motor learning. *J Neurophysiol* 79:1825–1838.
- Hilt PM, Berret B, Papaxanthis C, Stapley PJ, Pozzo T (2016) Evidence for subjective values guiding posture and movement coordination in a free-endpoint whole-body reaching task. *Sci Rep*. 6:23868. <http://dx.doi.org/10.1038/srep23868>.
- Hoffmann ER, Chan AHS (2012) Underwater movement times with ongoing visual control. *Ergonomics* 55:1513–1523.
- Hornet D, Decramer L, Tognono M, Gortan C (1990), Emulation of the EVA Soviet Suit for neutral buoyancy simulations, 20th

- International Conference on Environmental Systems. SAE Paper 901246.
- Kerr R (1973) Movement time in an underwater environment. *J Mot Behav* 5:175–178.
- Kerr R (1978) Diving, adaptation, and Fitts' law. *J Mot Behav* 22:255–260.
- Lackner JR, DiZio P (1994) Rapid adaptation to Coriolis force perturbations of arm trajectory. *J Neurophysiol* 72:299–313.
- Lackner JR, DiZio P (2000) Human orientation and movement control in weightless and artificial gravity environments. *Exp Brain Res* 130:2–26.
- Massion J, Fabre J-C, Mouchnino L, Obadia A (1995) Body orientation and regulation of the center of gravity during movement under water. *J Vestib Res* 5:211–221.
- Massion J (1992) Movement, posture and equilibrium: interaction and coordination. *Prog Neurobiol* 38:35–56.
- Mechtcheriakov M, Berger E, Molokanova G, Holzmüller W, Wirtenberger S, Lechner-Steinleitner C, De Col I, Kozlovskaya F (2002) Slowing of human arm movements during weightlessness: the role of vision. *Eur J Appl Physiol* 87:576–583.
- Nashner LM, McCollum G (1985) The organization of human postural movements: a formal basis and experimental synthesis. *Behav Brain Sci* 8:135–172.
- Papaxanthis C, Pozzo T, McIntyre J (2005) Kinematic and dynamic processes for the control of pointing movements in humans revealed by short-term exposure to microgravity. *Neuroscience* 135:371–383.
- Patron J, Stapley P, Pozzo T (2005) Human whole-body reaching in normal gravity and microgravity reveals a strong temporal coordination between postural and focal task components. *Exp Brain Res* 165:84–96.
- Prange GB, Jannink MJ, Groothuis-Oudshoorn CG, Hermens HJ, Ijzerman MJ (2006) Systematic review of the effect of robot-aided therapy on recovery of the hemiparetic arm after stroke. *J Rehabil Res Dev* 42:171–184.
- Ross HE, Crickmar SD, Sills NV, Owen EP (1969) Orientation to the vertical in free divers. *Aerosp Med* 40:728–732.
- Sarlegna F, Blouin J, Bresciani J-P, Bourdin C, Vercher J-L, Gauthier GM (2003) Target and hand position information in the online control of goal-directed arm movements. *Exp Brain Res* 151:524–535.
- Schaefer SY, Louder TJ, Foster S, Bressel E (2015) Effect of water immersion on dual-task performance: implications for aquatic therapy. *Physiother Res Int*. <http://dx.doi.org/10.1002/pri.1628>.
- Schneider S, Cheung JJH, Frick H, Krehan S, Micke F, Sauer M, Dalecki M, Dern S (2014) When neuroscience gets wet and hardcore: neurocognitive markers obtained during whole-body water immersion. *Exp Brain Res* 232:3325–3331.
- Shadmehr R, Mussa-Ivaldi FA (1994) Adaptive representation of dynamics during learning of a motor task. *J Neurosci* 14:3208–3224.
- Starkes J, Helsen W, Elliott D (2002) A ménage à trois: the eye, the hand and on-line processing. *J Sports Sci* 20:217–224.
- Terrier R, Forestier N, Berrigan F, Germain-Robitaille M, Lavallière M, Teasdale N (2011) Effect of terminal accuracy requirements on temporal gaze-hand coordination during fast discrete and reciprocal pointings. *J Neuroeng Rehabil* 8:10–30.
- Vernazza S, Martin N, Massion J (1999) Kinematic synergies and equilibrium control during trunk movement under loaded and unloaded conditions. *Exp Brain Res* 128:517–526.
- Watt DGD (1997) Pointing at memorized targets during prolonged microgravity. *Aviat Space Environ Med* 68:99–103.
- Weiss P, Gardette B, Chirié B, Collina-Girard J, Delauze HG (2012) Simulation and preparation of surface EVA in reduced gravity at the Marseilles Bay subsea analogue site. *Planet Space Sci* 74:121–134.
- White O, Lefèvre P, Wing AM, Bracewell RM, Thonnard J-L (2012) Active collisions in altered gravity reveal eye-hand coordination strategies. *PLoS One* 7:e44291.
- Wolpert DM, Ghahramani Z (2000) Computational principles of movement neuroscience. *Nat Neurosci* 3:1212–1217.
- Wolpert DM, Kawato M (1998) Multiple paired forward and inverse models for motor control. *Neural Netw* 11:1317–1329.