



HAL
open science

Multi-Sample Thermobalance for Rapid Cyclic Oxidation Under Controlled Atmosphere

Jean-Claude Salabura, Daniel Monceau

► **To cite this version:**

Jean-Claude Salabura, Daniel Monceau. Multi-Sample Thermobalance for Rapid Cyclic Oxidation Under Controlled Atmosphere. Materials Science Forum, 2004, 461-464, pp.689-696. 10.4028/www.scientific.net/MSF.461-464.689 . hal-04501299

HAL Id: hal-04501299

<https://hal.science/hal-04501299>

Submitted on 12 Mar 2024

HAL is a multi-disciplinary open access archive for the deposit and dissemination of scientific research documents, whether they are published or not. The documents may come from teaching and research institutions in France or abroad, or from public or private research centers.

L'archive ouverte pluridisciplinaire **HAL**, est destinée au dépôt et à la diffusion de documents scientifiques de niveau recherche, publiés ou non, émanant des établissements d'enseignement et de recherche français ou étrangers, des laboratoires publics ou privés.



Open Archive Toulouse Archive Ouverte (OATAO)

OATAO is an open access repository that collects the work of Toulouse researchers and makes it freely available over the web where possible.

This is an author-deposited version published in: <http://oatao.univ-toulouse.fr/>
Eprints ID : 2961

To link to this article :

URL : <http://dx.doi.org/10.4028/www.scientific.net/MSF.461-464.689>

To cite this version : Salabura, Jean-Claude and Monceau, Daniel (2004) [*Multi-Sample Thermobalance for Rapid Cyclic Oxidation Under Controlled Atmosphere*](#). Materials Science Forum, vol. 461 - 464 . pp. 689-696. ISSN 0255-5476

Any correspondence concerning this service should be sent to the repository administrator: staff-oatao@inp-toulouse.fr

Multi-Sample Thermobalance for Rapid Cyclic Oxidation Under Controlled Atmosphere

Jean-Claude Salabura and Daniel Monceau

CIRIMAT UMR 5085, ENSIACET-INPT, 31077 Toulouse Cedex 4, France
Daniel.Monceau@ensiacet.fr

Keywords: Cyclic Oxidation, Thermogravimetric Apparatus, Lamp furnace.

Abstract. When testing the resistance to oxidation of high temperature materials, the cyclic oxidation test is used as a reference because it integrates isothermal oxidation kinetics, oxide scale adherence, mechanical stresses, metallic alloy and oxide mechanical behavior and their evolution with time, in conditions close to the actual conditions of use. To fill the gap between the measurements of physical data (oxidation kinetics, interfacial energy, oxide toughness, growth stresses, coefficients of thermal expansion, mechanical properties of the alloy under the oxide scale,...) and the cyclic oxidation test, comprehensive scientific work is necessary, but also technological development and understanding of the practice of the cyclic oxidation test. This paper presents a new experimental tool, which allows the simultaneous measurement of the mass of several samples placed in the same controlled atmosphere during fast thermal cycles. This multi-sample thermobalance is described, in association with the description of the measurement methodology (i.e. "cyclic thermogravimetry"). First tests of performance of the apparatus are given, including heating and cooling rates and continuous mass measurements for a P91 alloy.

Introduction

The alloys' resistance to combined environmental attack and mechanical stresses relies partly on their ability to form a protective oxide scale, i.e. an oxide layer with low growth kinetics and high adherence to the alloy. Growth kinetics are first studied using isothermal laboratory tests, and the nature and microstructure of the oxide scale and underlying alloy are determined by post-mortem observations of the oxidized samples. The adherence of the oxide scale in terms of physical constants is more difficult to quantify. Several methods have been and are still developed, such as inverted blister test [1] or laser ultrasonics [2]. But generally, what is observed on samples after cooling is not adherence, but it is the extent of spalling. Spalling cannot be directly deduced from oxide scale adherence because it also depends on the intensity of stresses (growth stresses and stresses due to thermal expansion coefficients mismatch), on the thickness and mechanical properties of the oxide scale and of the metallic substrate. The quantification of the oxide spalling can be done, for example, by image analysis on the sample surface after cooling. But specific cooling experiments have been designed to evaluate the critical temperature drop before spalling [3] and then to link the extent of spalling with the adherence and mechanical properties data. Finally, measurements of oxidation kinetics, scale adherence, high temperature growth stresses, high temperature mechanical properties have to be combined with visco-plastic finite element modeling of the substrate-oxide scale system in order to predict if the alloy will form a protective oxide scale. Moreover, when the objective is the long term life prediction, all these measurements have to be done as a function of time because the microstructure and chemistry of the alloy under the

oxide scale evolve with time, which can greatly affect the mechanical properties of a coating, for example.

Facing this complexity, when testing the resistance to oxidation of high temperature materials, the cyclic oxidation test [5] is often used as the reference because it integrates isothermal oxidation kinetics, oxide scale adherence, mechanical stresses, metallic alloy and oxide creep induced by oxidation (and the evolution of these properties with time), in conditions close to the actual conditions of use. These results have then to be combined with high temperature corrosion, erosion, creep and fatigue tests results in order to provide the general behavior of the material. Moreover, coupling effects can also affect the lifetime (see [6] as an example).

To link the physical data (oxidation kinetics, interfacial energy, growth stresses, coefficients of thermal expansion, mechanical properties of the alloy and of the oxide,...) and the cyclic oxidation test, comprehensive scientific work is necessary. But, technological development and understanding of the cyclic oxidation test needs also to be done. Cyclic oxidation test is most of the time used as a qualitative or “screening test” tool. Two routes are followed to improve its quantification: 1/ the modeling of the kinetics [7-9], 2/ the development of new instruments or measurements methods. This paper deals with the second point, and especially with the use of continuous thermogravimetry in cyclic conditions.

Continuous Thermogravimetry in Cyclic Conditions

To quantify the oxidation kinetics in cyclic condition, an experimental method has been developed to dissociate the damage due to isothermal oxidation and the damage due to spalling during cooling (or re-heating) [10]. This method is also devoted to the identification of the parameters necessary for the modeling of cyclic oxidation kinetics [8-9]. It is based on a continuous recording of the mass as a function of time during the high temperature dwells of the cyclic oxidation test performed in a thermobalance. The analysis of the results proposed in [10] makes use of the series of characteristics points M_n^{bg} and M_n^{end} (Fig.1) to calculate independently the amount of oxide growth and the amount of spalling, at each cycle.

From the recording of the mass at the beginning and at the end of the high temperature dwells, and assuming some hypotheses (e.g. neglecting the amount of oxide formed during heating and cooling and neglecting spalling during the high temperature dwells), many data can be assessed : the Net Mass Gain; the Gross Mass Gain; the total mass of spalled oxide; the mass of metal loss; the average oxide scale thickness; the parabolic constant (k_p) as a function of the number of cycles; the fraction (P_n) of adherent oxide which spalls at each cycle.

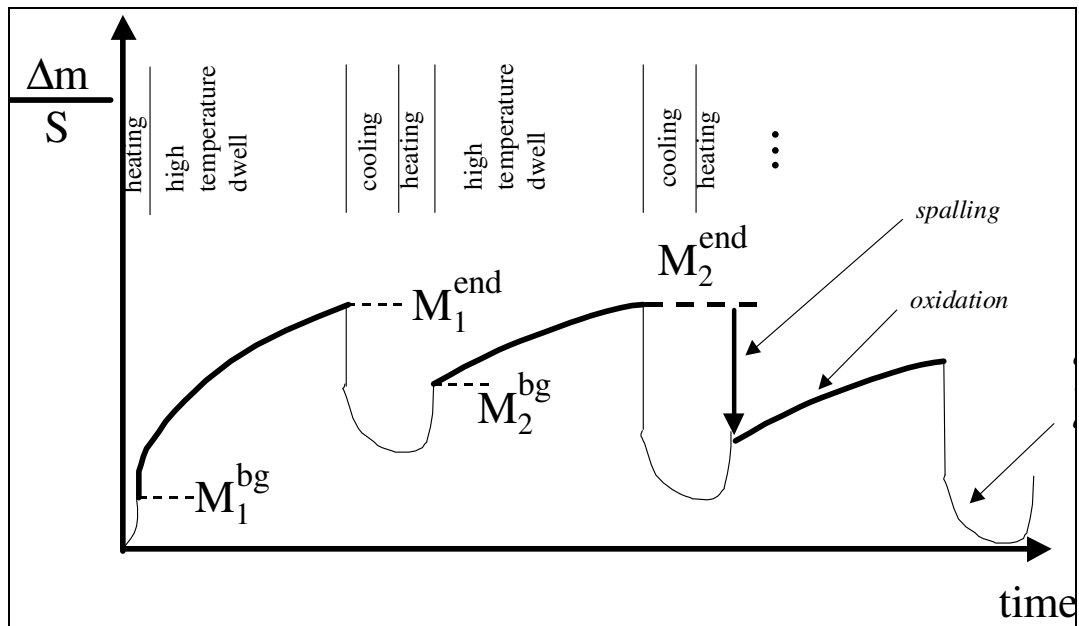

Fig. 1. Principle of the thermogravimetry in cyclic conditions [10].

Continuous thermogravimetry has some advantages on discontinuous measurements experiments during which samples need to be placed in crucibles in order to measure independently the Net Mass Gain and the mass of spalled oxide. Indeed crucibles are a source of experimental difficulties [11,12]. Moreover, with thermogravimetry, measurements are obtained automatically at each cycle. Nevertheless, the main disadvantage of this technique is to be expensive, because most of the cyclic oxidation studies require many samples during very long experiments (1000 to 20000 h). During our own work on a classic SETARAM thermobalance [10,13,14], we have experienced experimental difficulties such as slow heating and cooling and furnace breakdown after hundred of cycles.

That's why specific apparatus need to be developed, which should allow several samples to be analyzed at the same time with an economical gain linked to the small amount of experimental work needed to run an experiment.

Development of a new Thermobalance for Cyclic Oxidation

Since a few years, we have search for an experimental mean to automatically weight several samples at a time when they are oxidized during cycles at high temperature. This should be done in an apparatus allowing the control of the atmosphere (even during cooling) and able to fast heating and cooling. A new concept of thermobalance was then developed which combines a 6-lamps furnace with 6 balances. The 6 samples are placed in the same furnace but each of them is attached to an independent balance thanks to a specific geometry as seen on Fig. 2.

First Prototype. A prototype (Figs.2-4) has been built in order to test the thermal properties of such an apparatus, to test the control of the atmosphere, and to realize first tests of continuous mass recording on one of the 6 samples, using a low cost Sartorius Genius™ balance. Because these results were very encouraging, the building of a second apparatus with 6 high precision balances (1 μg accuracy) is being built.

Description of the apparatus. The details of the apparatus are given in Fig. 2-4 and Table 1. The furnace is an aluminum block, which can be translated up and down for an easy access to the samples. This block has been machined in order to be cooled by water running in a network of canals inside the block, and to have 6 elliptic and polished mirrors. For each half-

ellipse, a halogen lamp is placed at the closer focus axis and a sample at the other focus axis (see Fig 4). Each one of the six samples is hanged with one thermocouple running inside an alumina rod. 6 x 1000 W lamps are being used, for a total power of 6 kW. These lamps are of standard kind and then can be easily replaced with 500W or 1500W lamps. For the regulation, 3 PID regulators (Eurotherm 2408) are being used. The 6 lamps are divided in 3 sets of 2 lamps, and the furnace is then regulated as a three-zone furnace. The samples chamber consists in a quartz cylinder with an inside diameter of 46 mm, allowing 6 samples of 20x10mm maximum size. Different configurations are tested for the temperature measurement. The first results have been obtained with one type-S thermocouple placed inside each sample (samples were either a folded sheet of 270 μm thick 718 alloy with the thermocouple placed inside the “U” shape, or a thick P91 steel sample with the thermocouple inside a hole. The apparatus has been designed to run under primary vacuum or under gas flow, allowing the same controlled atmosphere during the high temperature dwells and the low temperature dwells.

1	One of the 6 balances (Sartorius Genius™ model)
2	Alumina rods for sample hanging
3	6 samples hanged independently
4	Large and heavy stainless steel cover
5	Chambers for thermal insulation of the electronic balance devices
6	Gas inlet and vacuum pump connection
7	Halogen lamps furnace
8	Gas outlet
9	Halogen lamps (1000W each)
10	Quartz tube (oxidation chamber for samples)
11	6 half-ellipses directly machined in an aluminum block, with mirror finish

Table 1. caption for Fig. 2, 3 and 4.

The first prototype has been equipped with only one Sartorius Genius™ balance (about 4kE). This balance has an accuracy of 10 μg for instantaneous mass measurements but is not adapted to long term measurements. For long term and small weight changes, specific balances for thermogravimetry should be used (from Sartorius™, Cahn™ or Setaram™ for example), but they are far more expensive (about 20 kE for one balance).

This first prototype was used to validate the thermal properties and the reliability of the furnace, but the mass recording tests were realized only on fast oxidizing materials (such as alloy P91). The currently developed second prototype includes 6 high accuracy balances. Electronic balances are placed in a large and heavy stainless steel cover (Fig.2 label 4). This chamber has a volume of 30 times the quartz tube volume. Finally, it should be noticed that a complete user interface software has been developed using the Labview© environment.

Performances of the prototype.

Tests realized during the year 2002 have shown excellent thermal performances :

- a maximum temperature of 1250°C has been obtained with thin 718 alloy sheet (270 μm thick) folded in “U” shape;
- a heating rate of 80°C/s up to 1000°C, and a cooling rate of 30°C/s at 1000°C (with the same samples). The cooling rate is fast because the quartz tube remains quite “cold”

during the high temperature dwell. This cooling rate could be slightly enhanced by using large air flow during cooling, or greatly enhanced by using thinner samples;

- the same temperature at $\pm 1^\circ\text{C}$ on the 3 samples which are used for the temperature regulation of each zone, and $\pm 5^\circ\text{C}$ on the three other ones;
- the temperature in the balance chamber (at the top of the apparatus) remains moderate (35°C after 24 hours of cycling at 1000°C) thanks to a succession of stainless steel chambers (Fig.3 label 5) which prevents large upward convection of hot gas. The horizontal walls between these chambers are drilled with six holes allowing the free movement of the six-alumina rod on which the samples are hanged.

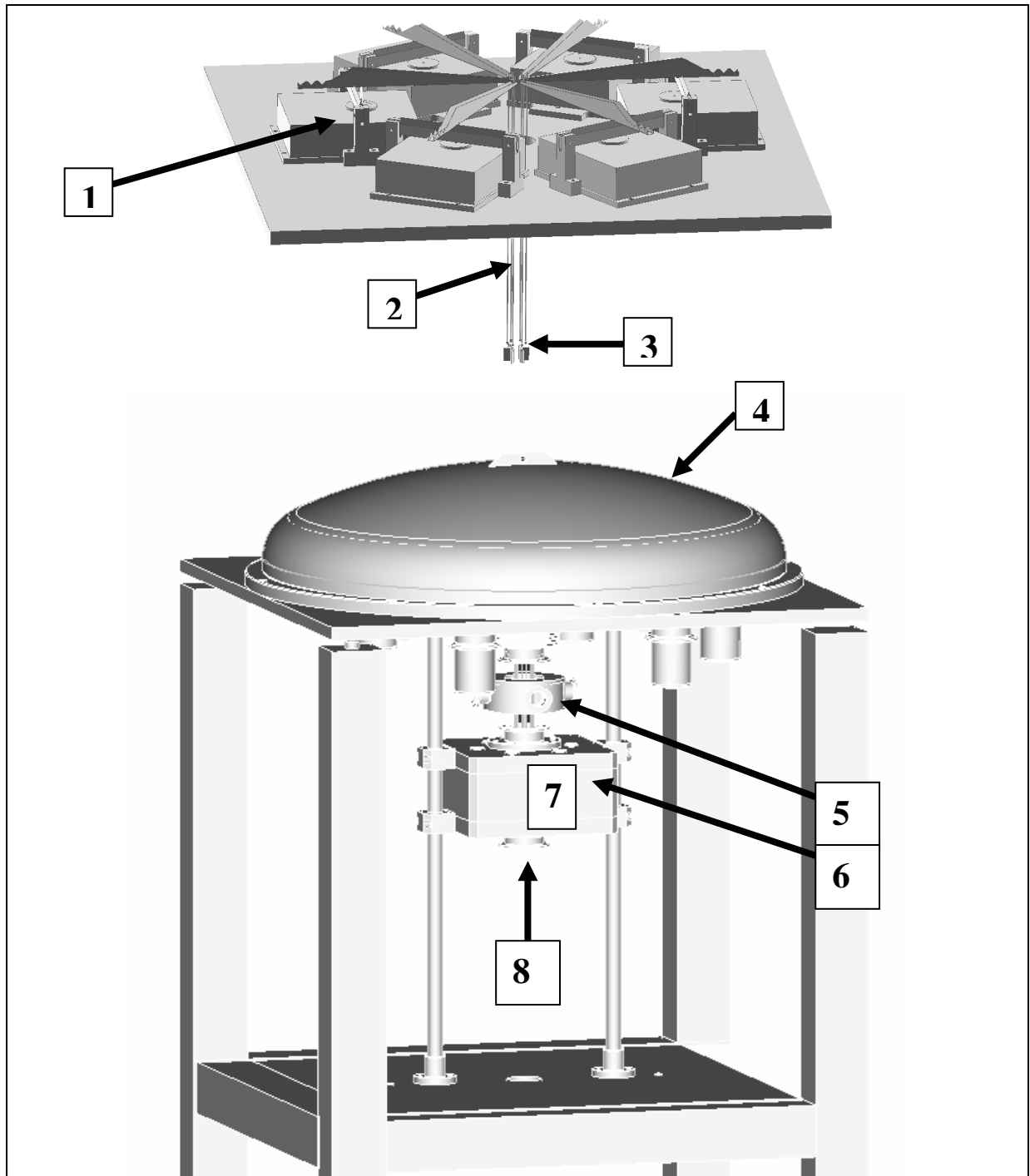

Fig. 2. Technical drawing of the first prototype of Thermobalance for cyclic oxidation (see Table 1 for caption).

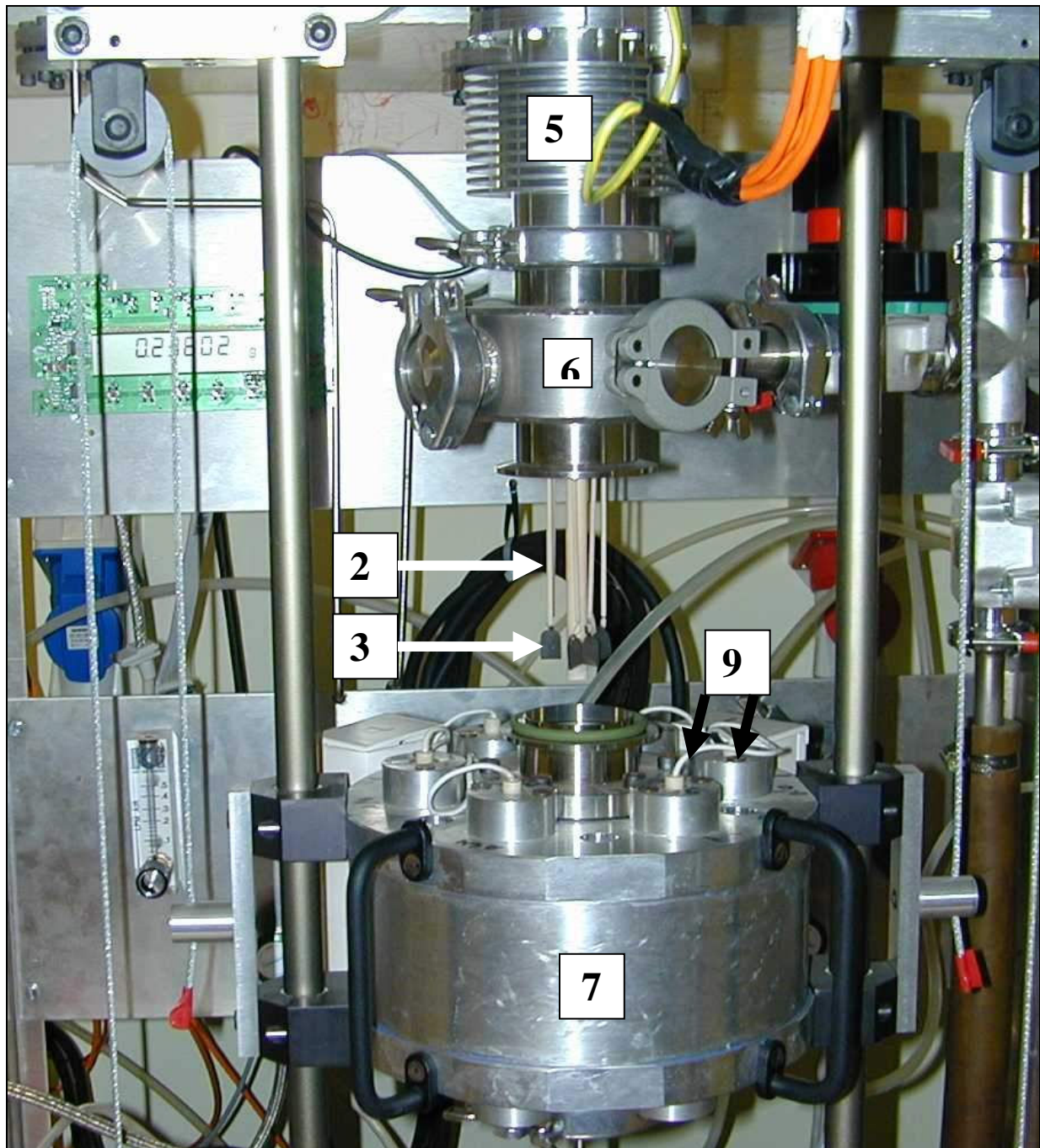

Fig.3. Photograph of the first prototype of cyclic thermobalance. On this photograph, the furnace (7) is placed down to have an access to the samples (3).

For the much more difficult case of alumina formers, experiments realized in a “classic” Setaram TAG24s thermobalance [12-13] have shown that an accuracy of one microgram was necessary to deal with one hour dwells at 1150°C if one wants to apply the full cyclic thermogravimetry method proposed in [10]. Nevertheless, even if the mass measurement is not accurate enough to apply this method, the general Net Mass Gain evolution as a function of the number of cycle is still obtained in very good conditions because of controlled atmosphere and of automatic measurement at each cycle, such as realized previously in [15-

17] but with multiple samples and a lamp furnace in our case. An example of thermal cycles and mass gain record for the oxidation of P91 alloy at 800°C is given in Fig 5-6.

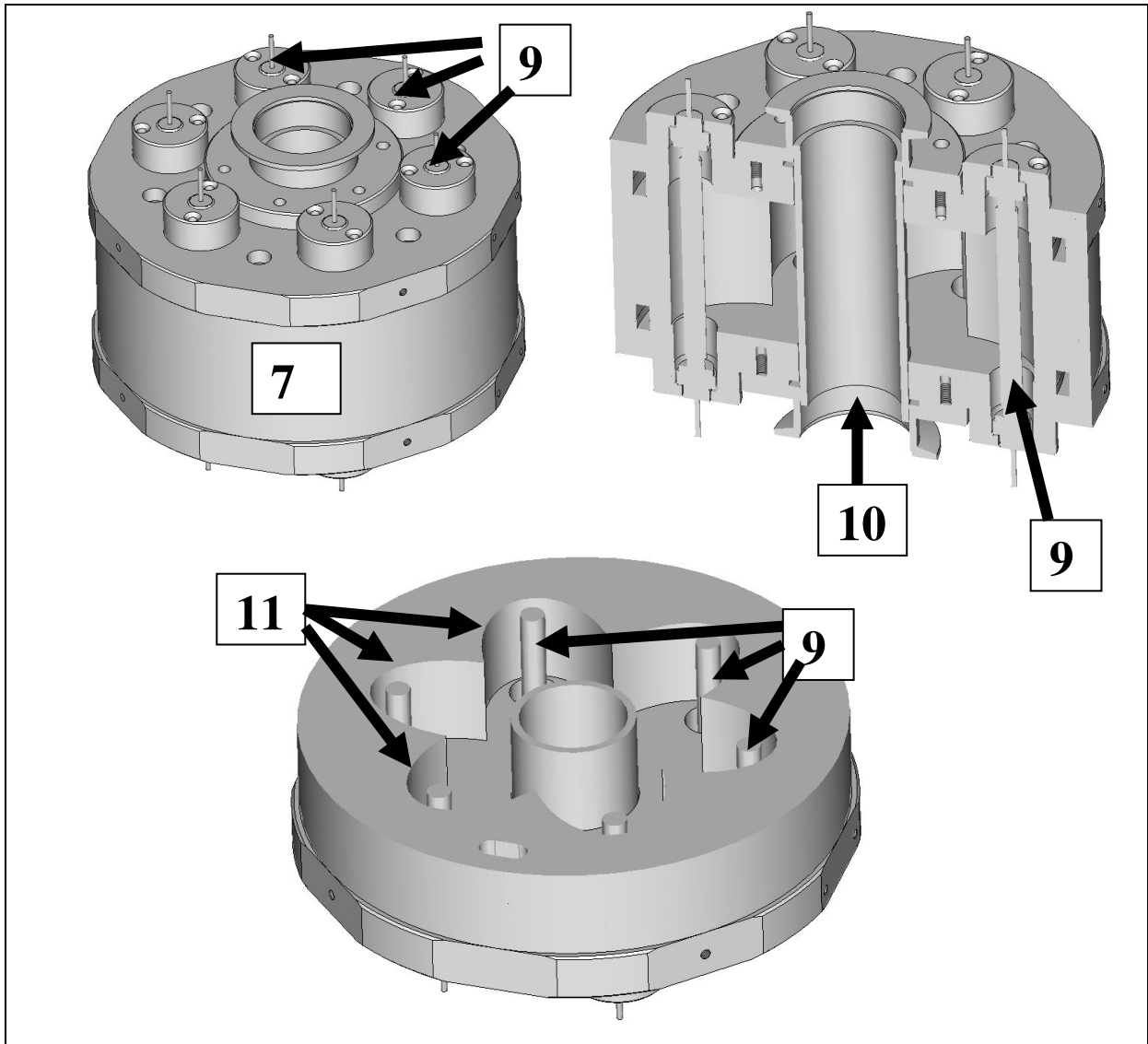
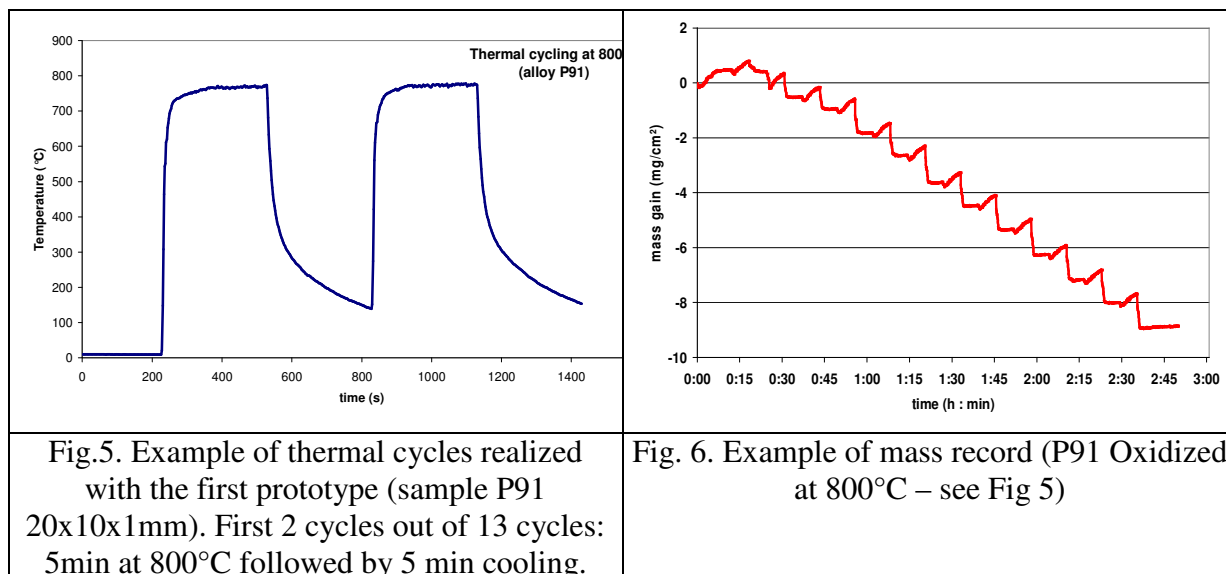

Fig.4. Technical drawing of the lamp furnace (7) showing the elliptic mirrors (11), lamp locations (9) and quartz tube (10).

Conclusions

In order to follow continuously the mass variation of samples in cyclic oxidation conditions, an apparatus has been designed and a first prototype has been built. The prototype has shown excellent thermal behavior. It allows heating samples up to 1200°C with a high rate. Fast cooling rate is also obtained similar to what can be obtained by taking samples out of a hot furnace. With lamp furnaces, it is shown that the thermal regulation can be excellent provided that the regulation thermocouples are placed inside the samples, and that one thermocouple is attached to each sample. Much work is needed with high precision and not drifting balance in order to be able to apply the cyclic thermogravimetry method [10] to the most difficult case of alumina formers below 1150°C. But the combination of a 6 lamps furnace with 6 samples weighted independently by 6 balances in the same controlled atmosphere appears already as a tool with a high potential [18] in order to quantify the cyclic oxidation test and the associated kinetics modeling.



References

- [1] J. Mougin, M. Dupeux, A. Galerie, and L. Antoni: Mater. Sci. Tech. Vol. 18 (2002), p.1217
- [2] G. Rosa, M.-H. Nadal, and R. Oltra: J. Appl Phys. Vol. 91 (2002), p 6744
- [4] H.E. Evans and R.C. Lobb: Corros. Sci. Vol. 24 (1984), p.209
- [5] M. Schütze and W.J. Quaddackers: (eds.): "*Cyclic Oxidation of High Temperature Materials (EFC 27)*." The European Federation of Corrosion, 1999.
- [6] S. Dryepontdt, E. Andrieu, D. Monceau, F. Crabos and C. Vernault: this issue.
- [7] J.L. Smialek: Metallurgical and Materials Transactions Vol. A 9A (1978), p.309.
- [8] C.E. Lowell, C. A. Barrett, R.W. Palmer, J.V. Auping and H.B. Probst: Oxid. Met. Vol. 36 (1991), p. 81
- [9] D. Poquillon and D. Monceau: Oxid. Met. Vol. 59 (2003), p. 409
- [10] D. Monceau and D. Poquillon: "Continuous thermogravimetry in cyclic conditions", to be published in Oxidation of Metals.
- [11] B.A. Pint, P.F. Tortorelli and I.G. Wright: in "*Cyclic oxidation of high temperature materials*" (M. Schütze and W. J. Quadackers, eds.), Vol. EFC 27, p. 111. IOM Communications Ltd, London, 1999.
- [12] H.J. Grabke and D.B. Meadowcroft: (eds.), "*Guidelines for Methods of Testing and Research in High Temperature Corrosion (EFC 14)*." The European Federation of Corrosion, 1995.
- [13] D. Poquillon, D. Oquab, B. Viguier, F. Senocq and D. Monceau: submitted to Materials Science and Engineering A, 2003
- [14] D. Poquillon, D. Oquab and D. Monceau: this issue.
- [15] J.C. Pivin et al.: Corros. Sci. Vol. 20 (1980), p.351.
- [16] U. Krupp, S.Y. Chang, A. Schimke and H J. Christ, in "*Lifetime modeling of high temperature corrosion processes*" (M. Schütze, W. J. Quadackers, and J. R. Nicholls, eds.), Vol. EFC 34, p. 148. Maney Publishing, London, 2001.
- [17] P. Vangeli and B. Ivarsson: Mater. Sci. Forum Vol. 369-372 (2001), p.785
- [18] The process and apparatus have been protected by the French patent application FR 03 00712 filed on January 23, 2003 by INP Toulouse.