



HAL
open science

Multi-way Variational NMT for UGC: Improving Robustness in Zero-shot Scenarios via Mixture Density Networks

José Carlos Rosales Núñez, Djamé Seddah, Guillaume Wisniewski

► **To cite this version:**

José Carlos Rosales Núñez, Djamé Seddah, Guillaume Wisniewski. Multi-way Variational NMT for UGC: Improving Robustness in Zero-shot Scenarios via Mixture Density Networks. NoDaLiDa 2023 - 24th Nordic Conference on Computational Linguistics, May 2023, Torshavn, Faroe Islands. hal-04384748

HAL Id: hal-04384748

<https://hal.science/hal-04384748v1>

Submitted on 10 Jan 2024

HAL is a multi-disciplinary open access archive for the deposit and dissemination of scientific research documents, whether they are published or not. The documents may come from teaching and research institutions in France or abroad, or from public or private research centers.

L'archive ouverte pluridisciplinaire **HAL**, est destinée au dépôt et à la diffusion de documents scientifiques de niveau recherche, publiés ou non, émanant des établissements d'enseignement et de recherche français ou étrangers, des laboratoires publics ou privés.

Multi-way Variational NMT for UGC: Improving Robustness in Zero-shot Scenarios via Mixture Density Networks

José Carlos Rosales Núñez

Université Paris Saclay & LISN

INRIA Paris

jose.rosales-nunez@inria.fr

Djamé Seddah

INRIA Paris

djame.seddah@inria.fr

Guillaume Wisniewski

Université Paris Cité,

LLF, CNRS

guillaume.wisniewski@u-paris.fr

Abstract

This work presents a novel Variational Neural Machine Translation (VNMT) architecture with enhanced robustness properties, which we investigate through a detailed case-study addressing noisy French user-generated content (UGC) translation to English. We show that the proposed model, with results comparable or superior to state-of-the-art VNMT, improves performance over UGC translation in a zero-shot evaluation scenario while keeping optimal translation scores on in-domain test sets. We elaborate on such results by visualizing and explaining how neural learning representations behave when processing UGC noise. In addition, we show that VNMT enforces robustness to the learned embeddings, which can be later used for robust transfer learning approaches.

1 Introduction

The specificities of user-generated content (UGC) leads to a wide range of vocabulary and grammar variations (Foster, 2010; Seddah et al., 2012; Eisenstein, 2013). These variations result in a large increase of out-of-vocabulary words (OOVs) in UGC corpora with respect to canonical parallel training data and raise many challenges for Machine Translation (MT), all the more since common language variations found in UGC are actually productive (there will always be new forms that will not have been seen during training). This fact limits the pertinence of “standard” domain adaptation methods such as fine-tuning¹ or normalization techniques (Martínez Alonso et al., 2016) and urges the development of robust machine translation models able to cope with out-

¹As the fine-tuning data will only reflect a frozen state of idiosyncrasies.

of-distribution (OOD) texts in a challenging zero-shot scenario in which the target distribution is unknown during training.

To address the problem raised by OOD texts, an increasing number of works (Setiawan et al., 2020; Schmunk et al., 2013; McCarthy et al., 2020; Przystupa, 2020; Xiao et al., 2020) explore the possibility to combine deep learning with latent variable (LV) models, which are indeed able to capture underlying structure information and to model unobserved phenomena. The combination of these models with neural networks was shown to increase performance in several NLP tasks (Kim et al., 2018). In this work, we focus on a specific latent variable model for MT, Variational NMT (VNMT) (Zhang et al., 2016) which has been reported to have good performance and interesting adaptability properties (Przystupa, 2020; Xiao et al., 2020).

The goal of this work is twofold. First, we aim to evaluate the performance of VNMT when translating a special kind of OOD texts: French social-media noisy UGC. To account for the challenges raised by the productive nature of UGC, we consider a highly challenging zero-shot scenario and assume that only canonical texts² are available for training the system. We hypothesize that, by leveraging on Variational NMT, latent models can build more robust representations able to represent OOD observations that are symptomatic of noisy UGC and automatically map them to in-distribution instances, which can be more easily translated.

Furthermore, to account for the diversity of UGC phenomena, we introduce a new extension of VNMT that relies on Mixture Density Networks (Bishop, 1994) and Normalizing Flows (Rezende and Mohamed, 2015). Intuitively,

²We consider the corpora generally used to train MT systems as “canonical” as they contain texts following the set of standard grammatical and morphological source-language rules.

each mixture component extracts an independent latent space to represent the source sentence and can potentially model different UGC specificities. Interestingly, extracting embeddings from our zero-shot model that has never seen any UGC data and using them in a classic transformer-based NMT model leads to a stronger, more robust to UGC noise model. This is in line with the regularizing character of VNMT (Zhang et al., 2016).

Our contributions can be summarized as follows:

- we study the performance, in a zero-shot scenario, of VNMT models and evaluate their capacity to translate French UGC into English, which resulted in a consistent improvement of translation quality;
- we introduce a new model that uses state-of-the-art transformer as the backbone of a variational inference network to produce robust representation of noisy source sentences, and whose results outperform strong VNMT and non-latent baselines when translating UGC in a zero-shot scenario. Specifically, our model demonstrates a high robustness to noise while not impacting in-domain translation performance;
- by probing the learned latent representations, we show the importance of using several latent distributions to model UGC and the positive impact of the ability of VNMT models to discriminate between noisy and regular sentences while maintaining their representation closer in the embedding space;
- we report evidence that our VNMT models act as regularizers of their backbone models, leading to more robust source embeddings that can be later transferred with a relatively high performance gain in our zero-shot UGC translation scenario.

2 Background and related works

Variational Neural Machine Translation Variational Inference (VI) methods (Kingma and Ba, 2015) are generative architectures capable, from a distributional perspective, of modeling the hidden structures that can be found in a corpus. In a sequence-to-sequence MT task, where \mathbf{x} and \mathbf{y} are respectively the source and target sentences, VNMT (Zhang et al., 2016) architectures assume

there exists an hidden variable \mathbf{z} modeling the implicit structure (i.e. relations) between the bilingual sentence pairs. In the context of UGC translation, we believe that this latent variable can capture the variations between a source sentence and its canonical, normalized form, recovering its underlying meaning and ensuring that the representation of the former is close to the representation of the latter.

To make computations tractable, in spite of the latent variable, VI combines a so-called *variational posterior* $q_\phi(\mathbf{z}|\mathbf{x}, \mathbf{y})$ that is chosen to approximate the *true* posterior distribution, with prior $p(\mathbf{z}|\mathbf{x})$; and a neural decoder generative distribution, $p_\theta(\mathbf{y}|\mathbf{x}, \mathbf{z})$, in charge of generating the translation hypothesis conditioned on the latent variable. Once the family of densities q is chosen, the parameters of the two distributions are jointly estimated to model the output \mathbf{y} by looking for the parameters (θ, ϕ) that maximizes the *evidence lower bound* objective function:

$$\log p_\theta(\mathbf{y}) \geq \mathbb{E}_{q_\phi(\mathbf{z}|\mathbf{x}, \mathbf{y})}[\log p_\theta(\mathbf{y}|\mathbf{x}, \mathbf{z})] - D_{KL}[q_\phi(\mathbf{z}|\mathbf{x}, \mathbf{y})||p(\mathbf{z}|\mathbf{x})] \quad (1)$$

Normalizing Flows One of the major caveats of variational methods is that choosing the prior $q(\mathbf{z})$ is a complicated process that requires some *a priori* knowledge of the task. In practice, a normal distribution with fixed parameters (generally $\mu = 0.0$ and $\sigma = 1.0$) is often chosen due to the simplicity of its re-parametrization for sampling. However, such an assumption can be restrictive when modeling more complex processes.

Regarding this issue, Rezende and Mohamed (2015) propose to enhance variational methods with Normalizing Flows (NF) (Tabak and Turner, 2013). A chain of normalizing flows is a series of simple bijective functions automatically chosen to extract a more suitable representation for the task at hand from a random variable, by alleviating the restrictions of choosing a default fixed prior. Concretely, a base distribution $q_0(\mathbf{z}_0)$, that generates the initial latent codes, \mathbf{z}_0 , undergoes a series of invertible and smooth transformations $f : \mathbb{R}^d \rightarrow \mathbb{R}^d$, called *flows*. Then, the random latent variables \mathbf{z} are transformed to the random variable $\mathbf{z}' = f(\mathbf{z})$ after each flow:

$$q(\mathbf{z}') = q(\mathbf{z}) \left| \det \frac{\partial f^{-1}}{\partial \mathbf{z}'} \right| = q(\mathbf{z}) \left| \det \frac{\partial f}{\partial \mathbf{z}} \right|^{-1} \quad (2)$$

Finally, we can build an arbitrarily K -long chain of f_k transformations to generate the final latent variables, \mathbf{z}_K , from the initial random variables, \mathbf{z}_0 , which is drawn from the base distribution $q_0(\mathbf{z}_0)$ (often chosen to be $\mathcal{N}(0, 1)$):

$$\begin{aligned} \mathbf{z}_K &= f_K \circ \dots \circ f_2 \circ f_1(\mathbf{z}_0) \\ \ln(q_K(\mathbf{z}_K)) &= \ln(q_0(\mathbf{z}_0)) - \sum_{k=1}^K \ln \left| \det \frac{\partial f_k}{\partial \mathbf{z}_{k-1}} \right| \end{aligned} \quad (3)$$

In MT, normalizing flows were recently used to improve VNMT models: Setiawan et al. (2020) show that using them in an in-domain evaluation setting results in an increase of +1.3 BLEU points on the IWSLT’14 (De-En) and +0.2 BLEU points on the WMT’18 (En-De); in a *simulated* out-domain evaluation, NF still improve translation quality: adding NF to the model trained on WMT’18 result in a +0.9 BLEU score improvements than the baseline Transformer system and +0.6 compared to the VNMT without using NF.

Mixture Density Networks Mixture Density Networks (MDN) are another interesting generalization of variational encoding for modeling UGC. By using MDN, the posterior distribution of the current decoding step $p(\mathbf{z}|\mathbf{x}, \mathbf{y}_t)$ is no longer approximated by a single variational distribution $q_\phi(\mathbf{z}|\mathbf{x}, \mathbf{y}_{1:t-1})$ but by a linear combination of variational posteriors $\tilde{q}_\phi^m(\mathbf{z}|\mathbf{x}, \mathbf{y}_{1:t-1})$:

$$p(\mathbf{z}|\mathbf{x}, \mathbf{y}_t) = \sum_{m=1}^M \alpha_m(\mathbf{x}, \mathbf{y}_{1:t-1}) \cdot \tilde{q}_m(\mathbf{z}|\mathbf{x}, \mathbf{y}_{1:t-1}) \quad (4)$$

where α_m are known as the mixing coefficients. Intuitively, an MDN can be interpreted as a combination of M variational encoders. Our intuition is that, since UGC contains a large number of different kind of variations, covering very different aspects ranging from morphology to phonetics, including lexicon and sentence structure (Seddah et al., 2012); by using several independent VI components we can account for multiple UGC phenomena. Thus, with an MDN, it is possible that each component of the variational encoder is able to model different UGC specificities, allowing us to better process UGC as a whole. In the past, MDN has been used to address sequence-to-sequence generative tasks, such as `SketchRNN` (Ha and Eck, 2018) and modeling of sequential environment states in reinforcement learning (Ha and Schmidhuber, 2018).

Gumbel-Softmax sampling Regarding the mixing coefficients definition, we also explore the use of a categorical probability distribution, for which probabilities are calculated by the network, such as in Ha and Eck (2018). Unlike theirs, our supervised end-to-end training requires backpropagating the error gradient through the variational network via reparametrized sampling (Kingma and Welling, 2014) which poses optimization challenges because of the discrete random variables used as latent vector for categorical distributions. For this reason, we use the reparametrization of this distribution via the Gumbel-Softmax sampling (Jang et al., 2017; Maddison et al., 2017), such that, the $\arg \max$ function is approximated by a softmax and generates the relaxed one-hot encoded samples, which correspond to the mixing coefficients:

$$\alpha_m = \frac{\exp(\log(\pi_m) + g_m)/\tau)}{\sum_{j=1}^M \exp(\log(\pi_j) + g_j)/\tau} \quad (5)$$

where $g_m \dots g_M$ are *i.i.d* samples from the Gumbel(0,1) distribution (Gumbel, 1954; Maddison et al., 2017), π_i the probability associated to the m -th MDN’s gaussian components, jointly generated by neural networks along with the computations of the corresponding parameters (μ_m, σ_m) for $m \dots M$; and τ the temperature parameter, which controls variability of the sampling. When $\tau \rightarrow 0$, the sampling exhibits a perfectly one-hot encoded output, whereas, conversely, when $\tau \rightarrow \inf$, the distribution approaches a uniform one across all the MDN’s components.

3 Extending Variational Methods for Robust MT

Our model adopts a variational encoder-decoder architecture inspired by `SketchRNN` (§2) that uses an MDN on the decoder’s variational network to model multiple and independent continuous generative variational distributions. However, unlike `SketchRNN`, we use a Transformer backbone for the encoder and the decoder and train our model in a end-to-end manner on canonical parallel corpora. In the following, we will first describe the general architecture of our model, denoted `multi-VNMT`, and then detail the encoder and decoder parameters.

General architecture Figure 1a represents the architecture of our model. The input sentence is

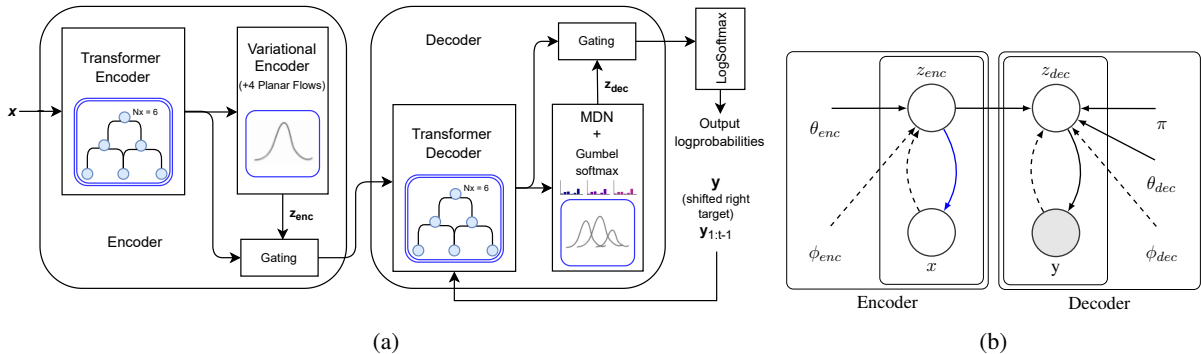

Figure 1: (a) VNMT-MDN architecture overview. (b) Directed graph of our encoder-decoder model variational inference. Dashed lines represent the variational approximation for the posterior distribution, and solid lines stand for the generative models. The blue arrow depicts the generative networks for source-side monolingual reconstruction distribution $p(x|z)$.

first processed by a standard Transformer encoder, the output of which is used by a Variational Encoder enhanced with NF to predict a latent representation of the input sentence. The latent representation and the output of the last layer of the Transformer encoder are combined using the gating mechanism of Setiawan et al. (2020).

This combined representation is then fed to the decoder that has a similar architecture: it is made of an “usual” Transformer decoder and a variational MDN that is sampled to obtain a prediction that will be combined to the Transformer output by (again) a gating mechanism.

The model can be trained in an end-to-end fashion using the “reparametrization trick” of Kingma and Welling (2014). In order to ensure that the estimated variances for the variational posteriors are positive, we used the *softplus* activation function (Zheng et al., 2015), as done in van den Berg et al. (2018)’s implementation.

In addition, concerning the training of the decoder’s MDN, we compare two different ways to compute the mixing coefficient: the first one consists in a vanilla non-latent softmax, the second on a relaxed categorical variational method that relies on a Gumbel-Softmax sampling (§2).

The model has been implemented in OpenNMT-py³ (Klein et al., 2018).

Encoder Our encoder backbone is the “standard” transformer of Vaswani et al. (2017), made of 6-layered transformer layers each with 8 attention heads. the *feed-forward* layers have 2,048 parameters and the dimension of lexical embeddings is 512. The dimension of the encoder vari-

ational network is 128. The network is extended with 4-flows Normalizing Planar Flows (Rezende and Mohamed, 2015).⁴

Following to Setiawan et al. (2020), we combine the last Transformer layer output to the latent vectors using a gating mechanism. We used a feed-forward network to transform the representation of dimension 128 predicted by the variational network into a representation of size 512 that matches the Transformer representation dimension.

In Figure 1b, we show the Transformer and variational encoding latent state z as being estimated ($p_{\theta}(z|x)$) approximating the posterior’s mean and variance, both learned using the reparametrization trick. In the figure, we can also observe how our model’s encoder comprises the Transformer backbone and VI network.

Decoder As for the encoder, the first component of the decoder is the “standard” Transformer decoder of Vaswani et al. (2017) and uses the same parameters as the Transformer encoder.

The Transformer decoder’s last layer output is passed to a 128-component MDN, with trainable parameters ϕ and π : ϕ encodes the mean and variance of each multivariate gaussian components; π contains the probabilities of the categorical distribution that generates the mixing coefficient for each component. Concisely, we estimate a posterior as a series of M posteriors parameterized by $\langle \phi, \pi \rangle$, i.e. $\tilde{q}_m^{\phi; \pi}(z_{dec}|x, y_{1:t-1})$, conditioned via the decoder’s Transformer, on both the gated latent encoder’s output and previous pre-

³<https://github.com/josecar25/MDN-VNMT>

⁴We used the implementation of <https://github.com/riannevdborg/sylvester-flows>

Corpus	#sentences	#tokens	ASL	TTR	#chars
<i>train set</i>					
WMT	2.2M	64.2M	29.7	0.20	335
OpenSub.	9.2M	57.7M	6.73	0.18	428
<i>test set</i>					
OpenSub.	11,000	66,148	6.01	0.23	111
newstest	3,003	68,155	22.70	0.23	111

Corpus	#sents	#tokens	ASL	TTR	#chars
<i>UGC test</i>					
PFSMB	777	13,680	17.60	0.32	116
MTNT	1,022	20,169	19.70	0.34	122
<i>UGC blind</i>					
PFSMB	777	12,808	16.48	0.37	119
MTNT	599	8,176	13.62	0.38	127
4Square	1,838	18,234	9.92	0.22	109

Table 1: Statistics on the French side of the corpora used in our experiments. TTR stands for Type-to-Token Ratio, ASL for average sentence length and #chars for the number of different characters.

dicted tokens, $\mathbf{y}_{1:t-1}$. The MDN’s mixing coefficient ($\alpha_m(\mathbf{x}, \mathbf{y}_{1:t-1})$) network also takes the same input and is computed separately, by either using a fully-forward layer with softmax activation or the relaxed categorical Gumbel distribution. Both networks computing \tilde{q}_m and α_m are jointly trained in an end-to-end fashion, such that translation loss is minimal for representations sampled from the resulting mixture, obtained according to Equation 4.

4 Training models

All systems are trained using a batch size of 4,096 tokens using the Adam optimizer (Kingma and Ba, 2015) accumulating gradients every 2 steps, and the Noam learning rate schedule (Vaswani et al., 2017) with 8K warmup steps. Throughout training, learning rate attains a maximum of $7e-4$ and minimum of $1e-5$. Both encoder and decoder Transformers are trained using 0.1 dropout and we employed 0.1 label smoothing (Szegedy et al., 2016). Training for, at most, 300K training iterations on a single Nvidia V100 took about 40 hours to converge for the `multi-VNMT` models, 34 hours for `VNMT-baseline` and 28 hours for the non-latent `Transformer` baseline. In order to avoid posterior collapse, and as done in Setiawan et al. (2020), we use β_C -VAE (Prokhorov et al., 2019), with values $\beta = 1$ and $C = 0.1$. Additionally, we used a Kullback-Leibler (KL) annealing schedule of 100K iterations for training. We set a 10% probability of dropping the target word (Bowman et al., 2016). We have chosen, as initial experimental configuration, $\tau = 1.0$ for the Gumbel-Softmax sampling temperature, which was selected mainly aiming to avoid artificial gradient scaling during backpropagation (c.f. Equation (5)). A beam of width 5 has been used for evaluation.

5 Experiments

Datasets We train our different MT models on two different French to English canonical parallel corpora: the first one is a subset of the WMT corpus, i.e. Europarl (v7) and NewsCommentary(v10) (Bojar et al., 2015) and the second one is the `OpenSubtitles’18` corpus (Lison et al., 2018). We used BPE tokenization (Sennrich et al., 2016) with 16K merge operations.

Detailed statistics on our corpora can be found in Table 1.

UGC Test Sets To evaluate the different NMT models, we consider two data sets of manually translated UGC: MTNT (Michel and Neubig, 2018) and the Parallel French Social Media Bank corpus (PFSMB) (Rosales Núñez et al., 2019)⁵ which extends the French Social Media Bank (Seddah et al., 2012) with English translations. These two data sets raise many challenges for MT systems: they notably contain characters that have not been seen in the training data (e.g. emojis), rare character sequences (e.g. inconsistent casing or usernames) as well as many OOVs denoting URL, mentions, hashtags or more generally named entities (NE). Most of the time, sOOVs are exactly the same in the source and target sentences.

We also consider the `4Square` corpus (Berard et al., 2019) as a blind test to validate our conclusions. To analyze our neural representations (§7), we use a subset of the PFSMB, called `PMUMT`, which contains 400 annotated and normalized French to English UGC sentences (Rosales Núñez et al., 2021).

Protocols Translation quality was evaluated using BLEU (Papineni et al., 2002) and chrF2 (Popovic, 2017) both computed by SACREBLEU

⁵<https://gitlab.inria.fr/seddah/parallel-french-social-mediabank>

(Post, 2018) with the ‘intl’ tokenization, after detokenizing the systems outputs.

In all the experiments we used the hyper-parameters values reported by Vaswani et al. (2017) and only choose the number of components of the MDN and the dimension of the latent representation on the validation set.⁶ Regarding the latent dimension, we conducted the same study with 128, 256 and 512 dimensions, with 128 being the best value. A beam of size 5 has been used for evaluation.

6 Results

In this section we present the main MT results to study MT performance of our methods.

MT Performance Our first experiment aims to compare the performance of `multi-VNMT`, the model we introduced in Section 3, to that of a “vanilla” Transformer model and of a state-of-the-art VNMT system using NF.⁷ The first baseline, a non-latent NMT architecture, `Transformer`, corresponds to our model without its VI components (i.e. with only the Transformer encoder and decoder); the second baseline, `VNMT-baseline`, corresponds to the equivalent of our NF setup (featuring 4 Planar Flows) from Setiawan et al. (2020).

Results achieved by these systems are reported in Table 2. We computed the 95% statistical significance by using a 1,000-samples bootstrapping, as in Koehn (2004). It should first be noted that the performances of the three systems we consider are identical when they are evaluated on in-domain data, whatever the evaluation measure considered (no statistically significant difference between the models). This observation highlights one of the strength of the proposed method: contrary to fine-tuning (arguably the most common method to adapt a system to a new domain) that often hurts performance on in-domain evaluation because of catastrophic forgetting (McCloskey and Cohen, 1989), the improvement of the quality of UGCs by the proposed method is not at the expense of the quality of translation of canonical texts.

It also appears that, on out-of-domain text, `multi-VNMT`, the approach proposed in this

⁶For the number of components we tested the following values 8, 16, 32, 64, 128 and 256 and found the optimal value to be 128.

⁷We re-implemented the system of Setiawan et al. (2020).

work, outperforms the standard Transformer model as well as the state-of-the-art VNMT model, supporting our hypothesis that considering several variational inference components allows to better capture all the variations that can be found in UGC and will result in improved translation quality. Interestingly, our system also performs better than Transformer when evaluated on out-domain canonical data and not only on UGC data. It should be noted, however, that the gains of our model are consistent but small and statistically significant mainly when translation quality is evaluated with chrF2.

Ablation study To better understand the impact of the different components of our model, we conduct an ablation study whose results are reported in Table 3. Overall, we obtain the best BLEU scores across all test sets for the “full” `multi-VNMT` model.

In particular, it appears that *static* latent representation (z_{static} in Table 3), where instead of sampling from the learned distributions, we retrieve their mean as output, show slightly better BLEU scores when translating the MTNT with the model trained on `OpenSubtitles` and the `newstest’14` test set with the model trained on `WMT` (+0.1 improvement in the two cases). However, results are inconsistent for UGC test sets and otherwise worse than those of the full model for both in-domain and canonical OOD test sets for our two training configurations. This might be explained by the lack of stochastic perturbations provided by the sampling step during training, leading the model to lose generalization during evaluation.

It is also interesting to note that using a categorical variational version of the mixing coefficients rather than the usual choice of computing them with a softmax improves translations quality: the latter is only performing better for the `newstest’14` test set when training on the `OpenSubtitles` corpus ($\pi_{non-latent}$). Following the same trend, the `WMT` training data configuration also show improvements when using the Gumbel-Softmax version, for which +0.8 and +0.3 BLEU point improvement were obtained for both the `PF-SMB` and `MTNT` UGC testsets, respectively.

Posterior collapse We have computed the average KL divergence of the variational decoder’s block (i.e. $D_{KL}(q_{\phi}(z|x, y)||p_{\theta}(z|x))$) on the encoder side of `multi-VNMT` and its ablated ver-

		WMT				OpenSubtitles				# params.
		PFSMB †	MTNT †	News ◊	OpenSubTest	PFSMB †	MTNT †	News	OpenSubTest ◊	
BLEU	Transformer	15.1	21.3	27.9	16.4	27.7	28.4	26.4	31.4	69M
	VNMT-baseline	15.5	21.4	27.9	16.4	28.0	28.9	26.5	31.4	72M
	multi-VNMT	16.0*	21.8	27.9	16.7*	28.4	29.2	26.4	31.5	77M
chrF2	Transformer	37.8	45.1	54.4	38.6	46.9	48.3	52.6	48.9	69M
	VNMT-baseline	38.3	45.1	54.6	38.6	47.6	49.2*	53.1*	48.9	72M
	multi-VNMT	38.5*	45.5	54.6	39.0*	47.7*	49.6*	52.9*	49.0	77M

Table 2: BLEU and chrF2 test scores for our models. The † symbol indicates the UGC test sets, and ◊ in-domain test sets. Highest metric for each test set are in bold; scores significantly better than Transformer ($p < 0.05$) are marked with a *.

	WMT				OpenSubtitles				# params.
	PFSMB †	MTNT †	News ◊	OpenSubTest	PFSMB †	MTNT †	News	OpenSubTest ◊	
multi-VNMT	16.0	21.8	27.9	16.7	28.4	29.2	26.4	31.5	77M
π non-latent	15.8	21.0	27.8	16.4	28.1	28.5	26.6	31.3	77M
-NF	15.3	21.6	28.0	16.5	28.3	28.8	26.1	31.3	76M
Z STATIC	16.5	20.9	28.0	16.4	28.1	29.3	26.2	31.4	76M
-MDN	16.5	20.9	27.8	16.6	27.7	28.7	26.2	31.3	73M

Table 3: BLEU test scores our ablated variants. The † symbol indicates the UGC test sets, and ◊ in-domain test sets.

sion without the MDN module in an in-domain setting. When trained (using the same KL annealing schedule) on OpenSubtitles (resp. WMT) this divergence is 0.21 (resp. 0.38) for multi-VNMT and 0.15 (resp. 0.33) when removing the MDN block, suggesting that our proposed architecture is less prone to suffer from the posterior collapse phenomenon.

7 Analyzing Latent Representations

In this Section, we describe several experiments aiming at understanding how multi-VNMT uncovers more robust representations than the VNMT baseline.

Impact of Noise in the Source First, to evaluate the perturbations that the model suffers when noise is present in the source, we measure the cosine similarity between the representations of the French noisy sentences and their normalized version, taking advantage of the PMUMT corpus (§5). More precisely, we compare the source-side embeddings of the 400 original noisy UGC sentences and their corresponding 400 fully-normalized versions built by VNMT-baseline and multi-VNMT. We observe that the average cosine similarity between the noisy and normalized learning representations of multi-VNMT is 0.36 compared to an average similarity of 0.26 for the representations of VNMT-baseline, sug-

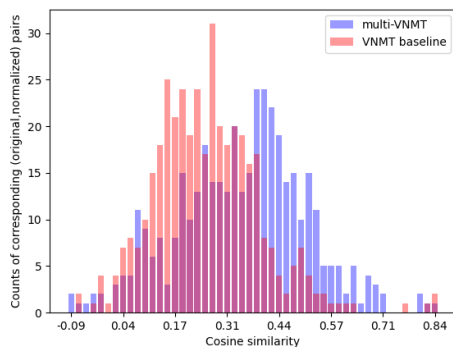

Figure 2: Distribution of cosine similarities between the representations of noisy and normalized sentences of PMUMT built by the encoder of VNMT-baseline and multi-VNMT.

gesting that the former provides more robust representations of UGC than the latter, a conclusion supported by the distribution of similarities shown in Figure 2.

Noisy vs normalized data To complete the previous analysis, we have reported, in Figure 3, the projection of the representations of noisy and normalized sentences computed by t-SNE. We can notice how both VNMT systems have a tendency to separate noisy and normalized sentences compared to Transformer, while both having higher cosine similarity than the latter.

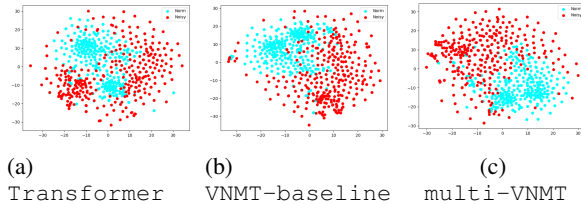

Figure 3: t-SNE projection of the encoder source embeddings for noisy sentences and their normalized versions.

	PFSMB [†]	MTNT [†]	News	OpenSub. [◊]
Transformer	27.7	28.4	26.4	31.4
Pre-trained init.	29.0	28.2	26.2	31.3
Frozen embs.	28.4	28.9	26.8	31.3
Fine-tuned	28.4	28.9	26.5	31.4

Table 4: Using VNMT-learned embeddings for transfer robust learned representations to the Transformer. The [†] symbol indicates the UGC test sets, and [◊] in-domain test sets.

Transferring learning representations As discussed above, in Figure 3 we noticed that VNMT seems to enforce noisy morphology modeling to the Transformer’s embeddings in an implicit way. This motivated us to study whether the information in such learning representations can be used by the Transformer backbone model and benefit from improved robustness while removing the direct latent space contribution, and notably, with the same number of parameters and architecture as Transformer. Thus, in Table 4, we report BLEU scores for the Transformer model trained on OpenSubtitles, by either initializing the VNMT-pretrained source-side embeddings before training, or fine-tuning (FT) the system. We have performed FT using the same data configuration as in OpenSubtitles and continued training for 3 epochs from the Transformer model in Table 2 while replacing the Transformer’s source embeddings by their VNMT-learned version’s weights.

Results in Table 4 provide evidence that VNMT enforces more robust embeddings, which perform consistently better over the PFSMB UGC test set compared to the baseline, the system Frozen embs giving the most consistent results over UGC. This system also achieves the best newstest’14 canonical OOD test set in the OpenSubtitles setup, while taking advantage of an increased robustness to UGC. These results

	PFSMB (Blind)	MTNT (Blind)	4Square
Transformer	19.7	25.0	21.9
+FT emb.	19.4	25.3	22.0
VNMT-baseline	20.0	25.3	22.0
multi-VNMT	20.0	26.4	22.5

Table 5: BLEU scores of our best systems on blind test sets.

indicate that our VNMT model leads to embeddings that are more robust to noise even when used in a classic transformer-based NMT baseline. An interesting path of research would be to evaluate these embeddings in other tasks and scenarios (e.g. Cross lingual UGC Q&A).

8 Blind test sets scores

We evaluated our best performing model (multi-VNMT trained on OpenSubtitles) on the blind test sets described in § 5, translating another set of tests to assess whether our approach proves useful for generalization over different types of UGC. We have also included the 4Square corpus (Berard et al., 2019) to validate our VNMT system on other domain of UGC (restaurant reviews). We also display the results when using the VNMT-baseline baseline and the Transformer model to assess improvement of our proposed architecture. We report such results in Table 5, where we can see that, when translating our blind UGC test sets, multi-VNMT consistently outperforms the baselines. It is interesting to notice that, although the in-domain performances for these 3 systems are very similar (between 31.4 and 31.5 BLEU in Table 2), the performance gap of blind UGC test sets is larger, i.e. +0.8 BLEU in average compared to the non-latent baseline.

9 Discussion

How MDN behaves under noise In Appendix A, we discuss how MDN components are activated when translating canonical in-domain and OOD texts, as well as UGC and normalized UGC. In Figure 4 and Table 6 in the Appendix, we show that noisy UGC activates MDN’s components with low correlation to other OOD canonical texts and even to its normalized version, which implies that the distribution of the kernels’ mixing coefficients is relatively among, the 4 test sets

considered, unique, i.e. relatively uncorrelated from the activation of other canonical texts (in-domain and OOD), when processing UGC. We cannot conclude, however, whether this observation is a consequence of the noise propagated through the model’s networks, but the enhanced robustness we witnessed in the translation results (much better performance to UGC, while keeping on-par or slightly better canonical (in-domain and OOD) performance) suggests that these mixing coefficients (that ultimately control the final decoding output) activate different variational posteriors (one per kernel) that can better process UGC.

Conclusions We introduced a novel VNMT architecture that provides improved performance and robustness over a state-of-the-art VNMT model, specifically when translating French UGC. An ablation study and blind test sets evaluation validate our architecture choice in regards of robustness capabilities for such texts. In addition, by exploring the learning representations trained by our VNMT model, and through conducting transfer learning experiments with such, we investigate the robustness brought to UGC, and show that VNMT enforces such property to the backbone model, bringing a promising avenue for more robust pre-trained neural learning representations. However, an open question arising from this work, it is currently unclear if the performance gain we observed is due to a better generalisation to distributional shift or if it corresponds to a better adaptation to noise in the input. Future works will be devoted to this question, which can be abstracted away to study whether UGC idiosyncrasies are a form of noise, some parts being learnable, or are rather points to a new domain.

Acknowledgments

We thank our anonymous reviewers for providing insightful comments and suggestions. This work was funded by the ANR projects ParSiTi (ANR-16-CE33-0021). This work was granted access to the HPC resources of IDRIS under the allocation 2021-AD011011748R1 made by GENCI. The authors are grateful to the CLEPS infrastructure from the Inria of Paris for providing resources and support.

References

- Alexandre Berard, Ioan Calapodescu, Marc Dymetman, Claude Roux, Jean-Luc Meunier, and Vassilina Nikoulina. 2019. Machine translation of restaurant reviews: New corpus for domain adaptation and robustness. In *Proceedings of the 3rd Workshop on Neural Generation and Translation@EMNLP-IJCNLP 2019, Hong Kong, November 4, 2019*, pages 168–176. Association for Computational Linguistics.
- Rianne van den Berg, Leonard Hasenclever, Jakub M. Tomczak, and Max Welling. 2018. Sylvester normalizing flows for variational inference. In *Proceedings of the Thirty-Fourth Conference on Uncertainty in Artificial Intelligence, UAI 2018, Monterey, California, USA, August 6-10, 2018*, pages 393–402. AUAI Press.
- Christopher M. Bishop. 1994. Mixture density networks. Technical report.
- Ondrej Bojar, Rajen Chatterjee, Christian Federmann, Barry Haddow, Matthias Huck, Chris Hokamp, Philipp Koehn, Varvara Logacheva, Christof Monz, Matteo Negri, Matt Post, Carolina Scarton, Lucia Specia, and Marco Turchi. 2015. Findings of the 2015 workshop on statistical machine translation. In *Proceedings of the Tenth Workshop on Statistical Machine Translation, WMT@EMNLP 2015, 17-18 September 2015, Lisbon, Portugal*, pages 1–46. The Association for Computer Linguistics.
- Samuel R. Bowman, Luke Vilnis, Oriol Vinyals, Andrew M. Dai, Rafal Józefowicz, and Samy Bengio. 2016. Generating sentences from a continuous space. In *Proceedings of the 20th SIGNLL Conference on Computational Natural Language Learning, CoNLL 2016, Berlin, Germany, August 11-12, 2016*, pages 10–21. ACL.
- Jacob Eisenstein. 2013. What to do about bad language on the internet. In *Proceedings of the 2013 conference of the North American Chapter of the association for computational linguistics: Human language technologies*, pages 359–369.
- Jennifer Foster. 2010. “cba to check the spelling”: Investigating parser performance on discussion forum posts. In *Human Language Technologies: The 2010 Annual Conference of the North American Chapter of the Association for Computational Linguistics*, pages 381–384, Los Angeles, California. Association for Computational Linguistics.
- Emil Julius Gumbel. 1954. *Statistical theory of extreme values and some practical applications; a series of lectures*. Applied mathematics series ; 33. U.S. Govt. Print. Office, Washington.
- David Ha and Douglas Eck. 2018. A neural representation of sketch drawings. In *6th International Conference on Learning Representations, ICLR 2018, Vancouver, BC, Canada, April 30 - May 3, 2018, Conference Track Proceedings*. OpenReview.net.

- David Ha and Jürgen Schmidhuber. 2018. Recurrent world models facilitate policy evolution. In *Advances in Neural Information Processing Systems 31: Annual Conference on Neural Information Processing Systems 2018, NeurIPS 2018, December 3-8, 2018, Montréal, Canada*, pages 2455–2467.
- Eric Jang, Shixiang Gu, and Ben Poole. 2017. Categorical reparameterization with gumbel-softmax. In *5th International Conference on Learning Representations, ICLR 2017, Toulon, France, April 24-26, 2017, Conference Track Proceedings*. OpenReview.net.
- Yoon Kim, Sam Wiseman, and Alexander M. Rush. 2018. A tutorial on deep latent variable models of natural language. *CoRR*, abs/1812.06834.
- Diederik P. Kingma and Jimmy Ba. 2015. Adam: A method for stochastic optimization. In *Proceedings of the 3rd International Conference on Learning Representations, ICLR 2015, San Diego, CA, USA, May 7-9, 2015, Conference Track Proceedings*.
- Diederik P. Kingma and Max Welling. 2014. Auto-encoding variational bayes. In *2nd International Conference on Learning Representations, ICLR 2014, Banff, AB, Canada, April 14-16, 2014, Conference Track Proceedings*.
- Guillaume Klein, Yoon Kim, Yuntian Deng, Vincent Nguyen, Jean Senellart, and Alexander M. Rush. 2018. Opennmt: Neural machine translation toolkit. In *Proceedings of the 13th Conference of the Association for Machine Translation in the Americas, AMTA 2018, Boston, MA, USA, March 17-21, 2018 - Volume 1: Research Papers*, pages 177–184.
- Philipp Koehn. 2004. Statistical significance tests for machine translation evaluation. pages 388–395.
- Pierre Lison, Jörg Tiedemann, and Milen Kouylekov. 2018. Opensubtitles2018: Statistical rescoring of sentence alignments in large, noisy parallel corpora. In *Proceedings of the Eleventh International Conference on Language Resources and Evaluation, LREC 2018, Miyazaki, Japan, May 7-12, 2018*.
- Chris J. Maddison, Andriy Mnih, and Yee Whye Teh. 2017. The concrete distribution: A continuous relaxation of discrete random variables. In *5th International Conference on Learning Representations, ICLR 2017, Toulon, France, April 24-26, 2017, Conference Track Proceedings*.
- Héctor Martínez Alonso, Djamé Seddah, and Benoît Sagot. 2016. From noisy questions to Minecraft texts: Annotation challenges in extreme syntax scenario. In *Proceedings of the 2nd Workshop on Noisy User-generated Text (WNUT)*, pages 13–23, Osaka, Japan. The COLING 2016 Organizing Committee.
- Arya D. McCarthy, Xian Li, Jiatao Gu, and Ning Dong. 2020. Addressing posterior collapse with mutual information for improved variational neural machine translation. In *Proceedings of the 58th Annual Meeting of the Association for Computational Linguistics, ACL 2020, Online, July 5-10, 2020*, pages 8512–8525. Association for Computational Linguistics.
- Michael McCloskey and Neal J. Cohen. 1989. Catastrophic interference in connectionist networks: The sequential learning problem. volume 24 of *Psychology of Learning and Motivation*, pages 109–165. Academic Press.
- Paul Michel and Graham Neubig. 2018. MTNT: A testbed for machine translation of noisy text. In *Proceedings of the 2018 Conference on Empirical Methods in Natural Language Processing, Brussels, Belgium, October 31 - November 4, 2018*, pages 543–553.
- Kishore Papineni, Salim Roukos, Todd Ward, and Wei-Jing Zhu. 2002. Bleu: a method for automatic evaluation of machine translation. In *Proceedings of the 40th Annual Meeting of the Association for Computational Linguistics, July 6-12, 2002, Philadelphia, PA, USA*, pages 311–318.
- Maja Popovic. 2017. chrF++: words helping character n-grams. In *Proceedings of the Second Conference on Machine Translation, WMT 2017, Copenhagen, Denmark, September 7-8, 2017*, pages 612–618. Association for Computational Linguistics.
- Matt Post. 2018. A call for clarity in reporting BLEU scores. In *Proceedings of the Third Conference on Machine Translation: Research Papers, WMT 2018, Belgium, Brussels, October 31 - November 1, 2018*, pages 186–191.
- Victor Prokhorov, Ehsan Shareghi, Yingzhen Li, Mohammad Taher Pilehvar, and Nigel Collier. 2019. On the importance of the Kullback-Leibler divergence term in variational autoencoders for text generation. In *Proceedings of the 3rd Workshop on Neural Generation and Translation*, pages 118–127, Hong Kong. Association for Computational Linguistics.
- Michael Przystupa. 2020. *Investigating the impact of normalizing flows on latent variable machine translation*. Ph.D. thesis, University of British Columbia.
- Danilo Jimenez Rezende and Shakir Mohamed. 2015. Variational inference with normalizing flows. In *Proceedings of the 32nd International Conference on Machine Learning, ICML 2015, Lille, France, 6-11 July 2015*, volume 37 of *JMLR Workshop and Conference Proceedings*, pages 1530–1538. JMLR.org.
- José Carlos Rosales Núñez, Djamé Seddah, and Guillaume Wisniewski. 2019. Comparison between NMT and PBSMT performance for translating noisy user-generated content. In *Proceedings of the 22nd Nordic Conference on Computational Linguistics*, pages 2–14, Turku, Finland. Linköping University Electronic Press.

- José Carlos Rosales Núñez, Djamé Seddah, and Guillaume Wisniewski. 2021. Understanding the impact of UGC specificities on translation quality. In *Proceedings of the Seventh Workshop on Noisy User-generated Text (W-NUT 2021)*, pages 189–198, Online. Association for Computational Linguistics.
- Sergej Schmunk, Wolfram Höpken, Matthias Fuchs, and Maria Lexhagen. 2013. Sentiment analysis: Extracting decision-relevant knowledge from ugc. In *Information and Communication Technologies in Tourism 2014*, pages 253–265, Cham. Springer International Publishing.
- Djamé Seddah, Benoit Sagot, Marie Candito, Virginie Moulleron, and Vanessa Combet. 2012. The french social media bank: a treebank of noisy user generated content. In *COLING 2012, 24th International Conference on Computational Linguistics, Proceedings of the Conference: Technical Papers, 8-15 December 2012, Mumbai, India*, pages 2441–2458.
- Rico Sennrich, Barry Haddow, and Alexandra Birch. 2016. Neural machine translation of rare words with subword units. In *Proceedings of the 54th Annual Meeting of the Association for Computational Linguistics, ACL 2016, August 7-12, 2016, Berlin, Germany, Volume 1: Long Papers*.
- Hendra Setiawan, Matthias Sperber, Udhyakumar Nallasamy, and Matthias Paulik. 2020. Variational neural machine translation with normalizing flows. In *Proceedings of the 58th Annual Meeting of the Association for Computational Linguistics, ACL 2020, Online, July 5-10, 2020*, pages 7771–7777. Association for Computational Linguistics.
- Christian Szegedy, Vincent Vanhoucke, Sergey Ioffe, Jonathon Shlens, and Zbigniew Wojna. 2016. Rethinking the inception architecture for computer vision. In *2016 IEEE Conference on Computer Vision and Pattern Recognition, CVPR 2016, Las Vegas, NV, USA, June 27-30, 2016*, pages 2818–2826. IEEE Computer Society.
- E. G. Tabak and Cristina V. Turner. 2013. A family of nonparametric density estimation algorithms. *Communications on Pure and Applied Mathematics*, 66(2):145–164.
- Ashish Vaswani, Noam Shazeer, Niki Parmar, Jakob Uszkoreit, Llion Jones, Aidan N Gomez, Łukasz Kaiser, and Illia Polosukhin. 2017. Attention is all you need. In I. Guyon, U. V. Luxburg, S. Bengio, H. Wallach, R. Fergus, S. Vishwanathan, and R. Garnett, editors, *Advances in Neural Information Processing Systems 30*, pages 5998–6008. Curran Associates, Inc.
- Tim Z. Xiao, Aidan N. Gomez, and Yarin Gal. 2020. Wat zei je? detecting out-of-distribution translations with variational transformers. *CoRR*, abs/2006.08344.
- Biao Zhang, Deyi Xiong, Jinsong Su, Hong Duan, and Min Zhang. 2016. Variational neural machine translation. In *Proceedings of the 2016 Conference on Empirical Methods in Natural Language Processing, EMNLP 2016, Austin, Texas, USA, November 1-4, 2016*, pages 521–530. The Association for Computational Linguistics.
- Hao Zheng, Zhanlei Yang, Wenju Liu, Jizhong Liang, and Yanpeng Li. 2015. Improving deep neural networks using softplus units. In *2015 International Joint Conference on Neural Networks (IJCNN)*, pages 1–4.

A How do MDN’s components react to UGC?

We proceeded to analyze and visualize how the MDN mixture coefficients react when translating our different test sets. In order to do so, in Figure 4 we report results for the canonical test sets, the normalized PMUMT corpus, and its noisy original UGC version. Each bar of the Wind Rose diagram represents one of the 128 independent trained distributions’ mixture weights, which have been normalized and scaled across the four graphics, and where the 7th MDN component seems to be consistently the one that drives most of the decoding for the presented experiments. Furthermore, we can notice that most mixing coefficients are, for the most part, have around 50% probability of contributing to the final inference mixture, despite not enforcing this behavior with any specific method (e.g. dropout). On the other hand, the visualization suggests that both yellow (50-60%) and blue components (30-40% of activation) are variable across test sets, being very similar between PMUMT Norm and OpenSubTest, which could indicate that the mixture components are learning to encode different types of texts, potentially working as an implicit topic modeling module. Regarding the visualization when translating PMUMT Noisy, the main MDN component identified above, seems less important even when compared to the out-of-domain newstest’14 set, which suggests that the MDN uses more dense representations when processing noisy texts.

In parallel, in Table 6 we display the covariance of these coefficients’ distributions between the combinations of their values when translating different kind of texts, along with the standard deviation and sparsity to describe how the MDN’s components behave.

Comparing the visualization in Figure 6, we can notice how the noisy UGC PMUMT and the

out-of-domain `newstest'14`, diverge from the in-domain `OpenSubTest` and normalized UGC `PMUMT` corpus. This correlation is evidenced in the results in Table 6, where `PMUMT noisy` has the lowest score when compared to every other corpus, even if its normalized version seems to be the most correlated to the in-domain evaluation. Specifically, `PMUMT Noisy` is the least correlated to in-domain `OpenSubTest` and out-of-domain `newstest'14` corpora, which points to the MDN reacting differently to content domain and UGC specificities in the noise; this observation is also supported by the associated figure. It is also interesting to notice that, according to the standard deviation and sparsity values, the active MDN components are more dense and variable for out-of-domain evaluation conditions, for the same Gumbel sampling temperature value.

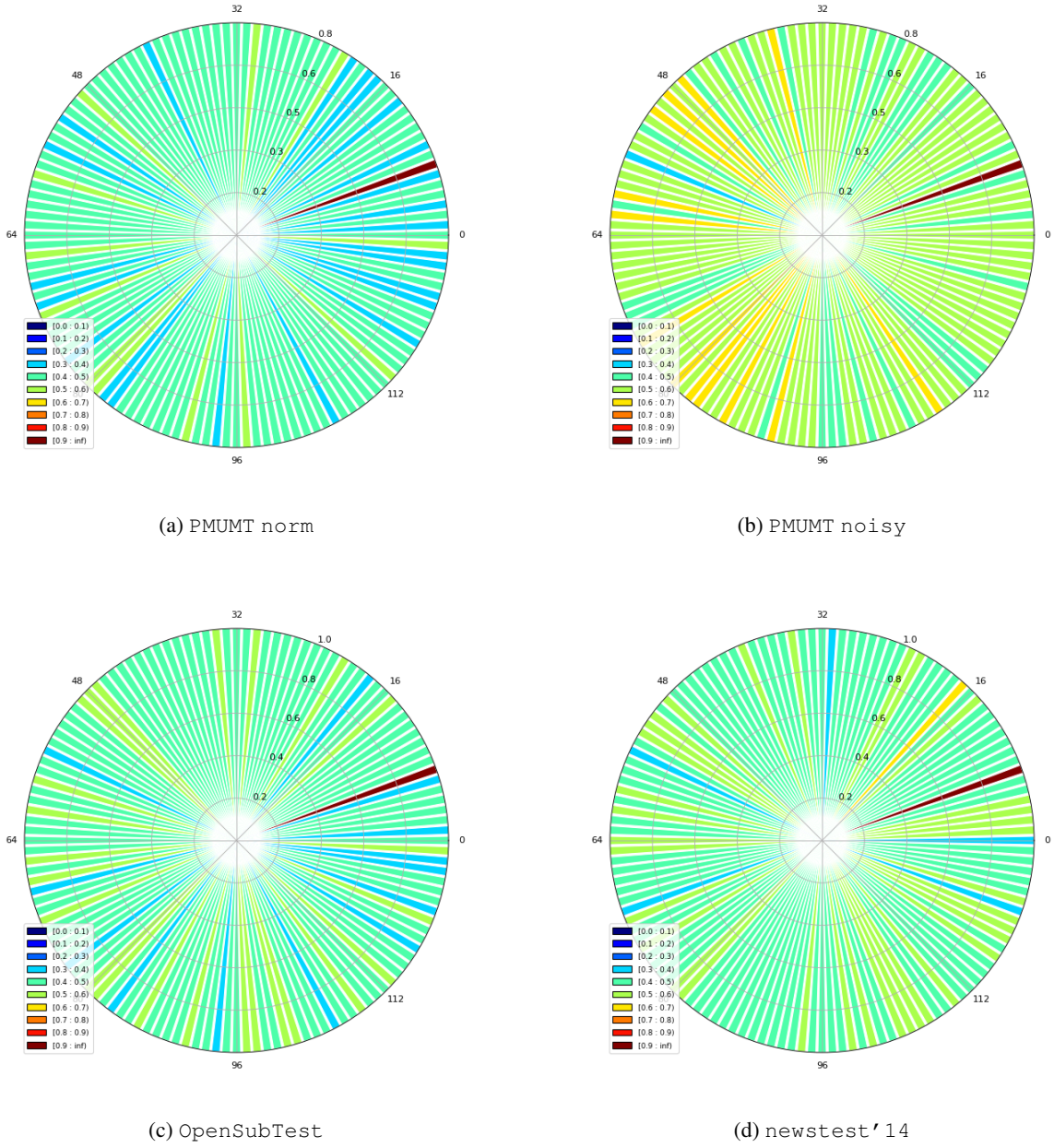

Figure 4: Average MDN mixture weights for test sets of different natures.

	PMUMT Noisy	News	OpenSubTest	std.	sparsity
PMUMT Norm	8.16	9.71	13.05	1.2e-3	0.387
PMUMT Noisy	—	7.72	7.86	1.0e-3	0.382
News	—	—	9.42	1.1e-3	0.384
OpenSubTest	—	—	—	1.1e-3	0.387

Table 6: Covariance between MDN mixture coefficients during inference for different types of test sets and sparsity for each set. *std.* stands for the standard deviation.