



HAL
open science

A tool-supported approach for modeling and verifying hybrid systems using EVENT-B and the differential equation solver SAGEMATH

Meryem Afendi, Amel Mammar, Régine Laleau

► To cite this version:

Meryem Afendi, Amel Mammar, Régine Laleau. A tool-supported approach for modeling and verifying hybrid systems using EVENT-B and the differential equation solver SAGEMATH. 18th International Conference on Software Technologies (ICSOFIT), Jul 2023, Rome, Italy. pp.71-83, 10.5220/0012080900003538 . hal-04344606

HAL Id: hal-04344606

<https://hal.science/hal-04344606v1>

Submitted on 14 Dec 2023

HAL is a multi-disciplinary open access archive for the deposit and dissemination of scientific research documents, whether they are published or not. The documents may come from teaching and research institutions in France or abroad, or from public or private research centers.

L'archive ouverte pluridisciplinaire **HAL**, est destinée au dépôt et à la diffusion de documents scientifiques de niveau recherche, publiés ou non, émanant des établissements d'enseignement et de recherche français ou étrangers, des laboratoires publics ou privés.

A Tool-Supported Approach for Modeling and Verifying Hybrid Systems using EVENT-B and the Differential Equation Solver SAGEMATH

Meryem Afendi¹, Amel Mammam² and Régine Laleau¹

¹ Univ Paris Est Creteil LACL, F-94010 Creteil, France

² SAMOVAR, Institut Polytechnique de Paris Télécom SudParis, Evry, France
{meryem.afendi,laleau}@u-pec.fr, amel.mammam@telecom-sudparis.eu

Index Terms—

Cyber-Physical System, EVENT-B, Refinement, Correctness Proof, Ordinary Differential Equation, Differential Equation Solver.

Abstract—The common mathematical model for cyber-physical systems is that of hybrid systems that enable combining both discrete and continuous behaviors represented by differential equations. In this paper, we introduce a formal approach, using EVENT-B and its refinement strategy, for specifying and verifying cyber-physical systems whose behavior is described by ordinary differential equations. To deal with the resolution of ordinary differential equations in EVENT-B, the approach is based on interfacing the differential equation solver SAGEMATH (System for Algebra and Geometry Experimentation) with the RODIN tool, a platform for EVENT-B projects development. For this purpose, we modeled and implemented the interface to the solver in EVENT-B using a RODIN plugin. This enables to reason on the EVENT-B specification and prove safety properties. The proposed approach was successfully applied on a frequently used cyber-physical system case studies.

I. INTRODUCTION

Hybrid systems involve explicitly and simultaneously continuous and discrete behaviors. In general, the state of a hybrid system is defined by the values of the continuous variables and the discrete mode of the controller. The formal modeling, verification and overall design of hybrid systems give rise to serious challenges. The development of techniques and tools to effectively design and verify hybrid systems has drawn the attention of many researchers. These approaches can be grouped into two categories: *model-checking-based* approaches and *proof-based* approaches. Proof-

based approaches use deductive verification to prove properties of hybrid systems. One of the strong points of these approaches is that they cover the specification of large hybrid systems of any kind, such as linear hybrid systems, nonlinear hybrid systems, etc. However, they require significant effort and a high expertise for the modeling and proof phases.

The work presented in this paper is achieved in the context of the DISCONT project [1] that aims at developing formal approaches for building correct cyber-physical systems (CPSs). The physical parts behavior of such systems is often described by ordinary differential equations (ODEs) [2] that involve an unknown function depending on a single variable. Following this objective, this paper introduces a formal approach to model CPSs using EVENT-B [3]. Our development is inspired by the approach introduced in [4] that consists in specifying an abstract model, *EventTriggered* model, where the controller interrupts the physical part when a particular event occurs, and then introducing a more concrete model, *TimeTriggered* model, where the controller interrupts periodically the physical part. The *EventTriggered* model describes an ideal behavior where the time is continuous and the sensors have continuous access to continuous measurements. *TimeTriggered* model represents a more realistic behavior where the sensors take periodic measurements. In our approach, the EVENT-B refinement mechanism allows to formalize and prove the refinement link between *EventTriggered* and *TimeTriggered* models.

The EVENT-B method is designed for modeling discrete systems, it does not support the resolution of ODEs. To deal with this limitation, we interface the RODIN tool, a platform for the EVENT-B modeling language, with a differential equation solver, SAGEMATH (System for Algebra and Geometry Experimentation) [5] in our case. This is achieved by implementing a plugin to RODIN that enables to call SAGEMATH. In [6], a first attempt at modeling cyber-

physical systems using EVENT-B is introduced. However, the models have proved to be not suitable to deal with systems with several properties. Moreover, the model is abstract and did not consider the resolution of ODEs. Consequently, it cannot be instantiated for the verification of a specific application. To overcome these limitations, the present paper introduces a new generic EVENT-B modeling for cyber-physical systems along with instantiation rules to apply for a specific application. The paper extends and improves the approach introduced in [6] with a set of instantiation rules that are defined to systematically build the model of a specific application. These rules enable to deal with more complex safety properties (a conjunction of atomic ones) and make the approach more general. We also consider the resolution of ODEs by interfacing RODIN with the SAGEMATH solver.

The contributions of the present paper are as follows:

- a generic formal proof approach for designing a correct cyber-physical system by considering any number of safety properties;
- an approach to deal with the resolution of linear and non-linear ODEs by interfacing RODIN and SAGEMATH;
- a tool as a bridge between SAGEMATH and the prover of RODIN.

The paper is organized as follows. The next section briefly describes the formal EVENT-B method and the ODE solvers. Section III is dedicated to a state of the art on proof-based approaches to deal with continuous aspects of CPSs and the approaches that interface theorem provers with computer algebra systems. Sections IV and VI introduce our approach for combining a differential equation solver with EVENT-B and illustrate it on a frequently used CPS case study. Section V describes the tool developed to support the approach. Finally, Section VII concludes and presents some future work.

II. BACKGROUND

A. EVENT-B

EVENT-B is a formal method introduced by J. Raymond Abrial to describe discrete systems using events [3]. It is based on set theory and predicate logic. An EVENT-B model is composed of machines and contexts. EVENT-B context represents the static part and includes constants C , abstract and enumerated sets S , and their properties specified as axioms A . A context may be extended by adding new elements. EVENT-B machine defines variables V which describe the machine state, invariants Inv which define the properties that must be satisfied whatever the state of

the system. The behavior of the system is described by a set of events of the form (**ANY X WHERE G THEN S END**), which update the state variables using the substitution S when its guard or condition G are satisfied. A machine may see contexts to have access to their contents. Table I gives the semantics of the different mathematical symbols used in the rest of the paper where:

- A and B denote any sets of elements,
- if a and b are elements of A and B respectively, $a \mapsto b$ denotes the tuple (a, b) ,
- A_1 and B_1 denote any subsets of A and B respectively,
- P denotes a predicate,
- S denotes any substitution.

An EVENT-B model gives rise to a set of Proof Obligations (POs) that aim at verifying its correctness. Basically, we have to verify that:

- the initialisation establishes the invariant, that means that the invariant is correct after the initialisation: $[INITIALISATION] Inv$, where the expression $[S]Inv$ denotes the substitution S applied to the formula Inv ; it denotes the weakest constraint on the before state such that the execution of S leads to an after-state satisfying Inv .
- for each event of the form (**ANY X WHERE G THEN S END**), we have to prove that the invariant Inv is preserved by the execution of the event:

$$\forall(S, C, V, X).(A \wedge G \wedge Inv \Rightarrow [S]Inv)$$

EVENT-B is supported by the open-source and free RODIN platform which is an Eclipse-based IDE. New features can be added to RODIN as plug-ins. For example, the theory plug-in [7] is a RODIN extension that allows one to define new data types like *REAL*, new operators, etc.

The key feature of EVENT-B to master system complexity consists in using abstract modeling to represent the abstract behavior of a given system and the refinement to introduce details by establishing the compliance between the abstract and the concrete models. The EVENT-B refinement technique preserves all the properties introduced and proved in the abstract model. To demonstrate that a concrete model *Conc* refines an abstract one *Abs*, it must be proved that all behaviors of *Conc* are included in those of *Abs*. For each event (**ANY X WHERE G THEN S END**) refined by the event (**ANY X_r WHERE G_r THEN S_r END**), we have to establish the following two proof obligations:

- *guard refinement*: the guard of the refined event should be stronger than the guard of the abstract

TABLE I
SOME EVENT-B SYMBOLS AND THEIR SEMANTICS

Concept	Notation	Semantics
R is a relation from A to B	$R \in A \leftrightarrow B$	$R \subseteq \{a \mapsto b \cdot a \in A \wedge b \in B\}$
R^{-1} is the inverse of R	R^{-1}	$R^{-1} = \{b \mapsto a \cdot a \mapsto b \in R\}$
Overriding R_1 by R_2	$R_1 \Leftarrow R_2$	if $R_1 \in A \leftrightarrow B$ and $R_2 \in A \leftrightarrow B$ then, $R_1 \Leftarrow R_2 = \{a \mapsto b \cdot a \mapsto b \in R_2 \vee (a \mapsto b \in R_1 \wedge a \notin \text{dom}(R_2))\}$
Image of A_1 by R	$R[A_1]$	$R[A_1] = \{b_1 \cdot (b_1 \in B \wedge \exists a_1 \cdot (a_1 \in A_1 \wedge a_1 \mapsto b_1 \in R))\}$
Domain of R	$\text{dom}(R)$	$\text{dom}(R) = \{a_1 \cdot (a_1 \in A \wedge \exists b_1 \cdot (b_1 \in B \wedge a_1 \mapsto b_1 \in R))\}$
Partial function f	$f \in A \mapsto B$	$f \in A \leftrightarrow B \wedge \forall a \cdot (a \in A \Rightarrow \text{card}(f[\{a\}]) \leq 1)$
Total function f	$f \in A \rightarrow B$	$f \in A \mapsto B \wedge \text{dom}(f) = A$
$v := E$	Assignment substitution	Assign the value of the expression E to the variable v
Guarded substitution	ANY X WHERE G THEN S END	if there are values of X such that P, then execute S

one:

$$\forall(S, C, S_r, C_r, V, V_r, X, X_r). \\ (A \wedge A_r \wedge \text{Inv} \wedge \text{Inv}_r \Rightarrow (G_r \Rightarrow G))$$

- *Simulation*: the effect of the refined substitution should be stronger than the effect of the abstract one:

$$\forall(S, C, S_r, C_r, V, V_r, X, X_r). \\ (A \wedge A_r \wedge \text{Inv} \wedge \text{Inv}_r \wedge [S_r]\text{Inv}_r \Rightarrow [S]\text{Inv})$$

B. Differential Equation Solvers

In this paper, we focus on ordinary differential equations (ODEs). An ODE involves an unknown function that depends on a single variable. The most common form of the ODEs that describes the evolution of hybrid systems is: $a_n(t)y^n(t) + \dots + a_2(t)y''(t) + a_1(t)y'(t) + a_0(t)y(t) = b(t)$, where the dependent variable is y and the independent variable is t . There are many computer algebra systems for solving ODEs, such as SAGEMATH [5] and Mathematica [8].

To find symbolic solutions for a given ODE, SAGEMATH mainly offers two functions: *desolve()* and *desolve_rk4*. *desolve()* that takes as parameters: $(de, dvar, ivar, ics)$, where: *de* represents the differential equation, *dvar* represents the unknown function, *ivar* represents the independent variable and *ics* is an optional argument denoting the initial conditions. *desolve_rk4(de, dvar, ivar, ics)* is very similar to *desolve*, it returns an approximate solution of the ODE in the form of tuple (t, y) .

III. STATE OF THE ART

Today, rigorous development methodologies based on mathematical and logical foundations are mature enough to support the development of hybrid systems. Formal approaches for modeling and verifying

hybrid systems can be divided into two categories: model checking-based approaches and proof-based approaches. Model-checking-based approaches use hybrid automata to model hybrid systems and algorithmic analysis methods to prove their safety properties [9], [10]. On the other hand, proof-based approaches use deductive verification to model and prove the properties of hybrid systems. In this paper, we are interested in proof-based approaches that can handle differential equations in hybrid systems modeling.

A. Event-B Modeling of Hybrid Systems

Hybrid EVENT-B, introduced in [11], extends EVENT-B to model both discrete and physical parts of CPSs. It defines two kinds of events: *mode events* that represent the traditional discrete EVENT-B events and the *pliant events* that describe the continuous behavior of the physical part by specifying the corresponding differential equation using piecewise absolutely continuous functions. On the domain of reals (\mathbb{R}), such functions are continuous over intervals, with possibly different values on the edges. The correctness of Hybrid EVENT-B models is ensured using a set of customised proof obligations patterns, defined in a way similar to classical EVENT-B. The method was successfully applied on many concrete examples and has been a source of inspiration for several approaches [12], [13], [14] including ours. Nevertheless, its major limitation is that it is not supported by any automatic tool. Therefore, the proof obligations must be generated and discharged manually, which makes it difficult to apply on critical systems since the proof phase is error-prone. Moreover, Hybrid EVENT-B does not provide any mechanism for solving

$ \begin{array}{l} \textit{Progress} \hat{=} \text{ANY } t_1 \\ \text{WHERE } t_1 \in \textit{TIME} \quad \wedge \quad t < t_1 \\ \text{THEN act1: } t := t_1 \\ \text{END} \end{array} $

Fig. 1. The EVENT-B specification of the time progression

differential equations in EVENT-B, which is a strength of our approach.

The approach, introduced by G. Dupont et al. in [14], proposes the use of the plug-in Theory of EVENT-B to handle continuous aspects of CPSs. The main idea of this approach is to describe the continuous evolution of time t and the generic continuous measurements, represented by the variable $plantV$, using some operators of the *DiffEq* theory. $plantV$ is indexed by \textit{TIME} ($plantV \in \textit{TIME}^1 \rightarrow S$) where S is a constant defined in the associated context to be equal to: \mathbb{R}^n with n is the number of the system continuous variables. The progression of time t is modeled by an event named *Progress* (see Figure 1). It states that the new value of t_1 will become greater than its previous value, ($t < t_1$).

This approach introduces a theory named *DiffEq* that provides several abstract operators to model ODEs in EVENT-B. To prove the safety properties of hybrid systems, it defines properties on these ODEs using operators like the operator *Solvable* which ensures that the ODEs are solvable. Nevertheless, no mechanism is provided to solve the concrete ODEs. Therefore, this approach remains quite abstract regarding the resolution of differential equations. In this paper, we extend this abstract model and use some operators of the theory *DiffEq* to solve ordinary differential equations using EVENT-B and SAGEMATH. Solving ODEs allows proving the safety properties of hybrid systems in a *Time-Triggered* system which is the most concrete model of CPSs that we could achieve. Moreover, these solutions will serve in developing an automation tool to simulate the continuous behaviors of hybrid systems in EVENT-B.

B. Differential Logic ($d\mathcal{L}$)

In [15], Platzer introduces a proof-based approach to model and verify hybrid systems. It is based on a first-order differential logic in the domain of reals (\mathbb{R}), named dynamic differential logic $d\mathcal{L}$, and its associated proof calculus. Both are supported by the theorem prover KeYmaera [16] and its successor KeYmaera X [17] which is interfaced with the computer algebra system Mathematica. The advantage of this approach

¹Defined on \mathbb{R}^+

is its ability to model and verify the evolution of continuous measurements, represented by differential equations, using $d\mathcal{L}$ formula. Hybrid systems are described in $d\mathcal{L}$ using hybrid programs, whose hybrid dynamics arise from combining a specific set of ordered discrete programming constructs with continuous ODEs. Most hybrid programs are modeled by the formula, $(ctrl; plant)^*$, where $ctrl$ denotes the execution of the controller (discrete evolution), followed by the physical part $plant$ (continuous evolution), with a non-deterministic repetition. $d\mathcal{R}$ (differential Refinement Logic) [18] extends $d\mathcal{L}$ by introducing the notion of refinement on hybrid systems. Interestingly, *Event-Triggered* and *Time-Triggered* systems are specified with $d\mathcal{R}$ and proof obligations are defined to check that *TimeTriggered* is a refinement of *EventTriggered*. $d\mathcal{R}$ is not supported by any prover, it cannot be used for critical systems since the proof obligations are manually generated and discharged. To overcome this limit, we propose a new correct-by-construction approach to prove this refinement, based on EVENT-B to take advantage of its well-defined refinement process and its support tools. Unlike $d\mathcal{R}$, developing hybrid systems with EVENT-B enables to deal with the complexity of the system by incrementally introducing the properties. Moreover, EVENT-B enables to have a good view on the proof activity and its different steps that helps us to have a better understanding of the system.

IV. A GENERIC FORMAL APPROACH FOR SOLVING ORDINARY DIFFERENTIAL EQUATIONS IN EVENT-B

Besides the proposed formal approaches, Kopetz [4] introduces an approach that we have found interesting because it considers a CPS at different levels of abstraction that allows to deal with the complexity of such systems. The proposed approach consists in specifying an abstract model, *Event-Triggered* model, in which the controller interrupts the physical part when certain events occur. Then defining a more concrete model, *Time-Triggered* model, in which the controller interrupts periodically the physical part.

This section describes our contribution in using the Event-B method and SAGEMATH for modeling and verifying hybrid systems. Our proposal consists in modeling the $(ctrl; plant)^*$ idiom of *Event* and *Time-triggered* models with the event-based paradigm of EVENT-B. The link between these models are expressed as a refinement relationship. Our approach reuses the abstract model and the theories introduced in [14], such as *DiffEq*, to handle continuous aspects of hybrid systems. This allows us to

model and verify the compliance between *Time* and *Event-Triggered* systems. The approach follows the development schema depicted in Figure 2. Using the EVENT-B refinement technique, we start by an abstract model that specifies the continuous aspects of CPSs. Then we enrich the model step by step to introduce a concrete model that includes the solutions of ODEs. Therefore, the approach consists of four generic models: model *System_M* denotes the continuous part of CPSs, model *EventTriggered_M* describes the interaction between the continuous and the discrete parts of CPSs, model *TimeTriggered_M* represents the discrete time and *TimeTriggeredDesolve_M* introduces the resolution of ODEs in EVENT-B by calling the SAGEMATH functions. The whole models can be downloaded from <https://github.com/CPSsWithEventB/Main/blob/main/README.md>.

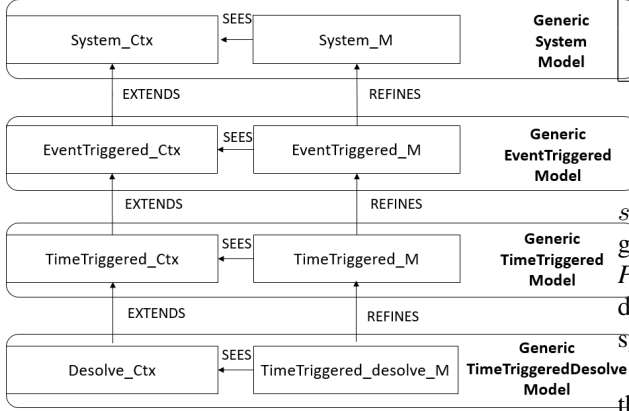

Fig. 2. Generic EVENT-B specification with the $B_{desolve}$ function

A. Generic System Model

Generic System model consists of the context *System_Ctx* that defines a set of constants and axioms required to model the continuous part of CPSs, and the machine *System_M* that introduces two variables: the independent variable $t \in \mathbb{R}^+$ and the continuous variable $plantV$, defined as a partial function, $plantV \in [0, t] \rightarrow \mathbb{R}$. Variable t represents the current time and evolves according to the event *Progress* (see Section III-A) that we have slightly modified to avoid the Zeno problem, where the time interval continually gets smaller and smaller which prevents the controller from reacting exactly at the right moment. For this purpose, we have defined in the context *System_Ctx* a constant parameter σ whose value depends on the properties of the specific system, $\sigma \in \mathbb{R}^+$. We added in the event *Progress* the constraint: $t' - t \geq$

```

Plant ≜ ANY e, plant1
WHERE
  grd1: e ∈ DE(ℝ)
  grd2: Solvable([0, t] - dom(plantV), e)
  grd3: plant1 ∈ [0, t] - dom(plantV) → ℝ ∧
        AppendSolutionBAP(e, [0, t] - dom(plantV),
        [0, t] - dom(plantV), plant1)
THEN
  act1: plantV := plantV ⋈ plant1
END

```

Fig. 3. EVENT-B modeling of the *plant* event

```

Ctrl ≜
ANY value
WHERE
  grd1: exec = ctrl
  grd2: value ∈ ℝ
  grd3: ∀p.p ∈ PROP ∧ value ∉ prop_evade_values(p)
        ⇒ (prop_safe(p))(plantV(t), value) = TRUE
THEN
  act1: ctrlV := value
  act2: exec := prg
END

```

Fig. 4. EVENT-B modeling of the controller behaviour

σ to guarantee that the time progression is always greater than σ , where t' is a parameter of the event *Progress* that specifies the new value of time t . t' is determined according to the properties of the modeled system.

The behavior of the physical part is modeled by the event *Plant* (see Figure 3). Event *Plant* uses the operator *AppendSolutionBAP* defined in *DiffEq*, where e represents the abstract ODE and belongs to $DE(S)$ which is a set of differential equations built on S . *AppendSolutionBAP* enables to update the value of $plantV$ ($plantV \leftarrow plant1$) between the last time and the current value of t ($[0, t] - dom(plantV)$).

B. Generic EventTriggered model

At this level, we express the properties desired for the system. To do this, *EventTriggered_Ctx* extends *System_Ctx* by adding a set of properties *PROP*. Moreover, we define the constant *prop_safe* (resp. *prop_evt_trig*) that maps each property to its safety envelope (resp. the boundary of the safety envelope). Note that the safety envelope is calculated from the safety requirements that the system must satisfy to guarantee that the controller will react exactly at the right moment.

EventTriggered_M model refines *System_M* model to specify the idiom $(ctrl; plant)^*$ whose semantics is as follows: the physical part (*Plant*) evolves in

parallel with the time (*Progress*) and both are interrupted just before crossing the boundary of the safety envelope, represented by the formula $prop_evt_trig$. Nevertheless in *EVENT-B*, it is not possible to state that two events should be executed simultaneously. A first solution to this limitation is to merge the events *Progress* and *Plant* in order to make both evolve at the same time. This option has proved to be unsatisfactory for systems with several physical parts that are modelled then by several *Plant* events. Moreover, making the time progress before the control may lead to a deadlock if the time progresses too fast and the controller cannot take any action to guarantee the safety of the system. So, we have chosen to keep the time progression as a separate event that is enabled between the *controller* and the *Plant*. For this purpose, we have introduced two new variables $ctrlV$ and $exec$. Variable $ctrlV$ represents the control variable and belongs to \mathbb{R} , $exec$ takes its value in $\{prg, ctrl, plant\}$; it is a flag used to model the alternation between the progression of time, the control and physical parts as follows: $(ctrl; prg; plant)^*$. Moreover, we associate with each property a set of values for variable $ctrlV$, called $prop_evade_values$ that ensure that the boundary of the safety envelope is never crossed. Thus, the controller is modeled by the event *Ctrl* (see Figure 4) that checks, for each property p , that the safety envelope is true if the chosen value *value* for the control variable $ctrlV$ does not belong to the evade values of p (Guard $grd3$).

Similarly, the event *Progress* is refined to specify that: (1) the event is enabled when it is the turn of time to progress (Guard $grd2$) and (2) time must not evolve beyond a value that makes the physical part cross the boundary of a safety property (Guard $grd3$) to guarantee that the time will not progress too much and make the safety properties false if the controller fails to react in time. In other words, the new value of time t_1 should be chosen such that the physical part reacts safely during the period from the last progression of time t and t_1 ($t_1 - t$). The parts added by refinement are written in blue (see Figure 5). The physical part, represented by the event *Plant*, is refined by replacing the abstract differential equation e with that defined for a function denoted f_evol_plantV to describe the evolution of the state variable $plantV$ according to the system discrete state (clause **WITH** of Figure 6).

C. Generic TimeTriggered Model

The sensors of the *TimeTriggered* model take periodic measurements of physical parts and its controller executes for each sensors update. The main difference between the *Event-* and the *Time- Triggered* models

```

Progress REFINES Progress  $\hat{=}$ 
ANY  $t_1$ 
WHERE
  grd1:  $t_1 \in TIME \wedge t_1 - t \geq sigma \wedge t < t_1$ 
  grd2:  $exec = prg$ 
  grd3:  $\forall p.p \in PROP \wedge ctrlV \notin prop\_evade\_values(p)$ 
   $\Rightarrow (prop\_evt\_trig(p))(plantV(t), t_1 - t, ctrlV) = TRUE$ 
THEN
  act1:  $t := t_1$ 
  act2:  $exec := plant$ 
END

```

Fig. 5. Refinement of the *Progress* event in the *EventTriggered* level

```

Plant REFINES Plant  $\hat{=}$ 
ANY  $plant1$ 
WHERE grd1:  $exec = plant$ 
  grd2:  $plant1 \in [0, t] - dom(plantV) \rightarrow \mathbb{R}$ 
  grd3:  $ode(f\_evol\_plantV(ctrlV), plant1(t), t) \in DE(\mathbb{R})$ 
  grd4:  $Solvable([0, t] - dom(plantV),$ 
   $ode(f\_evol\_plantV(ctrlV), plant1(t), t))$ 
  grd5:  $AppendSolutionBAP(ode(f\_evol\_plantV(ctrlV),$ 
   $plant1(t), t), [0, t] - dom(plantV),$ 
   $[0, t] - dom(plantV), plant1)$ 
WITH  $e : e = ode(f\_evol\_plantV(ctrlV), plant1(t), t)$ 
THEN
  act1:  $plantV := plantV \Leftarrow plant1$ 
  act2:  $exec := ctrl$ 
END

```

Fig. 6. Refinement of the *Plant* event in the *EventTriggered* level

is in the modeling of the progression of time. The longest time between *TimeTriggered* sensors updates is bounded by a symbolic duration named $epsilon$ and which must be defined by the designer of the specific hybrid system. Thus, the controller is executed at least every $epsilon$ units of time. So, we refine event *Progress* by adding the formula $t' - t \leq epsilon$ to state that the time cannot progress by more than $epsilon$ units of time. Moreover, since the controller of a *TimeTriggered* model must make a choice that will be safe for up to $epsilon$ units of time, we define a new safety envelope named $prop_safeEpsilon$. Event *Ctrl* is refined by adding a guard to ensure that $prop_safeEpsilon$ is true for the new value of $ctrlV$ when this later does not belong to the evade values of a property ($grd4$ of Figure 7). Let us remark that the guard related to the formula $safe$ is kept because we are in a generic model and do not have yet the concrete expression of $safe$. This guard will be removed when modelling a specific application giving rise to a proof obligation to establish that the other guards imply it.

```

Ctrl REFINES Ctrl  $\hat{=}$ 
ANY value
WHERE
  grd1: exec = ctrl
  grd2: value  $\in \mathbb{R}$ 
  grd3:  $\forall p.p \in PROP \wedge value \notin prop\_evade\_values(p)$ 
   $\Rightarrow (prop\_safe(p))(plantV(t), value) = TRUE$ 
  grd4:  $\forall p.p \in PROP \wedge value \notin prop\_evade\_values(p)$ 
   $\Rightarrow (prop\_safeEpsilon(p))(plantV(t), value) = TRUE$ 
THEN
  act1: ctrlV := value
  act2: exec := prg
END

```

Fig. 7. Refinement of the *Ctrl* event at *TimeTriggered* level

D. Generic *TimeTriggeredDesolve* Model

Generic *TimeTriggeredDesolve* model refines the generic *TimeTriggered* model to introduce the resolution of ODEs. Depending on the linearity of ODE, a specific SAGEMATH *Desolve* function is used. Thus, we have to distinguish two cases:

- **case of linear ODE**: in that case, we use the function *B_desolve* that is defined to model analytical solutions of ODEs in EVENT-B. It returns a function of type $\mathbb{R} \rightarrow \mathbb{R}$ that represents the values of the continuous variables of a given hybrid system. Introducing this function in our generic approach allows us to prove the safety properties of hybrid systems in a *TimeTriggeredDesolve* system, which was not possible with the approach introduced in [6]. Moreover, this function serves to establish the link between our EVENT-B models and the differential equation solver SAGEMATH.

$$B_desolve \in (\mathbb{N} \times \mathbb{R} \times (\mathbb{R}^+ \rightarrow \mathbb{R}) \times \mathbb{R}^+ \times (\mathbb{R}^+ \times \mathbb{R})) \rightarrow (\mathbb{R} \rightarrow \mathbb{R})$$

- the first and the second parameters denote the order and the right term of the considered ODE.
- the third parameter denotes *the unknown function*, represented by a continuous variable.
- the fourth parameter denotes *the independent variable*, represented by a discrete variable and typed by \mathbb{R}^+ .
- the last parameter denotes the initial values of both the independent variable and the unknown function.

Event *Plant* is refined to calculate the value of *plant1* during the period from *lastTime* to *t* using the function *B_desolve*, which is specified by the guard *grd3* (see Figure 8). This guard is used

```

Plant REFINES Plant  $\hat{=}$ 
ANY plant1, lastTime
WHERE
  grd1: exec = plant
  grd2: lastTime  $\in \mathbb{R}^+ \wedge dom(plantV) = [0, lastTime]$ 
  grd3: plant1 = B_desolve( $1 \mapsto ctrlV \mapsto plantV$ 
   $\mapsto t \mapsto (lastTime \mapsto plantV(lastTime))$ )
  grd4: plant1  $\in [0, t] - dom(plantV) \rightarrow \mathbb{R}$ 
  grd5: ode(f_evol_plantV(ctrlV), plant1(t), t)  $\in DE(\mathbb{R})$ 
  grd6: Solvable( $[0, t] - dom(plantV)$ ,
  ode(f_evol_plantV(ctrlV), plant1(t), t))
  grd7: AppendSolutionBAP(ode(f_evol_plantV(ctrlV),
  plant1(t), t),  $[0, t] - dom(plantV)$ ,
   $[0, t] - dom(plantV)$ , plant1)
THEN
  act1: plantV := plantV  $\Leftarrow$  plant1
  act2: exec := ctrl
END

```

Fig. 8. Refinement of the *Plant* event by calling the DE solver

to link the abstract event to its refinement. It enhances the guards *grd6* and *grd7* that aim at modeling the differential equation solution using the operators of the theory *DiffEq*. It serves to verify the properties assumed by the operators *Solvable* and *AppendSolutionBAP* about the solutions of the given ODEs in order to establish a link between our approach and the theory *DiffEq*. The parameters *dvar*, *ivar* and *ics* (see Section II-B) are represented respectively by the dependent variable *plantV* and the independent variable *t* as well as the initial values of these variables. The parameter *lastTime* is introduced to represent the last progression of time at which *plantV* has been calculated. The solution of a given differential equation is calculated from *lastTime* to *t* in order not to overwrite the old values of the continuous variable *plantV*.

- **case of non linear ODE**: if the ODE is linearisable, we apply the same refinement using the *Desolve* function on the linear form while proving such a linearisation using the approach defined in [19]. Otherwise, we use the SAGEMATH *desolve_rk4*() function that returns an approximate solution for ODEs. This function is defined by:

$$B_desolve_rk4 \in \mathbb{R} \times (\mathbb{R}^+ \mapsto \mathbb{R}) \times \mathbb{R}^+ \times (\mathbb{R}^+ \times \mathbb{R}) \times (\mathbb{R}^+ \times \mathbb{R}^+) \rightarrow (\mathbb{R}^+ \mapsto \mathbb{R})$$

B_desolve_rk4 returns a function of type $\mathbb{R}^+ \mapsto \mathbb{R}$ that represents the values of the continuous variables. The first four parameters are the same parameters as those of *B_desolve*. The last parameter is used to specify the interval denoted

$[t_1, t_2]$ for which the values of $plantV$ are calculated. The refinement of the event $Plant$ in case of non linear ODE is similar to that for linear ODE with the guard $grd3$ replaced with:

$$plant1 = B_desolve_rk4(f_evol(ctrlV)) \mapsto \\ plantV \mapsto t \mapsto (lastTime \mapsto plantV(lastTime)) \\ \mapsto (lastTime \mapsto t))$$

E. Modeling the Safety Properties

The main goal of the discrete part represented by the controller is to ensure the safety properties of a specific hybrid system. To model these safety properties in EVENT-B, a constant function $prop \in \mathbb{R}^n \rightarrow BOOL$ is defined in the context $Desolve$ where n denotes the number of variables occurring in the property. Then an invariant is added in the machine $TimeTriggered_desolve_M$, inv^2 : $\forall x \cdot x \in dom(plantV) \Rightarrow prop(plantV(x)) = TRUE$, where $plantV$ will be replaced by the specific continuous variables. To discharge the PO generated for this invariant, we added to the event $Plant$ the following guard $grd8$: $\forall xx \cdot xx \in dom(plant1) \Rightarrow prop(plant1(xx)) = TRUE$. This guard will be removed on a specific case to generate a proof obligation that aims at proving that this guard is actually satisfied.

F. Correctness of the Specification

TABLE II
RODIN PROOF STATISTICS FOR THE GENERIC MODELS

Specific_Models	Total	Automatic	Interactive
System	8	1	7
EventTriggered	19	11	8
TimeTriggered	2	1	1
TimeTriggeredDesolve	5	3	2

PO1: $lastTime \in dom(plantV) \wedge plantV \in \mathbb{R} \rightarrow \mathbb{R} \wedge 1 \mapsto ctrlV \mapsto plantV \mapsto t \mapsto (lastTime \mapsto plantV(lastTime)) \in dom(B_desolve) \wedge B_desolve \in \mathbb{N} \times \mathbb{R} \times P(\mathbb{R} \times \mathbb{R}) \times \mathbb{R} \times (\mathbb{R} \times \mathbb{R}) \rightarrow P(\mathbb{R} \times \mathbb{R})$

PO2: $\forall x \cdot x \in dom(plantV \Leftarrow plant1) \implies prop((plantV \Leftarrow plant1)(x)) = TRUE$

Table II gives the statistics of the POs generated for the correctness of our generic models. It is noticeable that 47% of them were automatically discharged. These POs include the correctness of the events that model the behavior of the physical parts and the controller, as well as the correctness of their refinement. The POs related to the well-definedness have been interactively discharged under RODIN using the properties of *Reals* and *DiffEq* theories. To prove the compliance between $TimeTriggered_M$ and $EventTriggered_M$ machines, Rodin has generated a

² x and xx enable to cover all the moments from the beginning until the current time

set of proof obligations that we have discharged in the $TimeTriggered_M$ machine. In these generic models, as we have kept the guard related to the formula $safe$ and $prop_evt_trig$ in the event $Progress$ (see Figure 5), the refinement proofs are rather simple and related mainly to the type checking of the different variables and the feasibility of the abstract and the concrete models.

To prove the correctness of the $TimeTriggeredDesolve$ model, RODIN has generated five proof obligations, three of them were automatically discharged. The remaining proof obligations are as follows:

- $PO1$ is a well-definedness proof obligation which aims at proving that the guard $grd3$ of the event $Plant$ (see Figure 8), added to model the solution of the generic ODEs using the function $B_desolve$, is well defined. This guard assigns to the parameter $plant1$ the solution of the generic ordinary differential equation obtained using the function $B_desolve$. To discharge this proof obligation, we must prove that the set of the results returned by $B_desolve$ is equal to the set of definition of $plant1$. This proof obligation was discharged using some rewriting rules, the properties of the *Reals* theory and some invariants defined in refined machines.
- $PO2$ is generated to prove that the event $Plant$ preserves the system safety property, specified using the constant $prop$. This proof obligation was discharged by replacing the value of $plant1$ by the result returned by $B_desolve$.

G. Instantiating the Generic Approach

To design a specific case study following our generic approach, we instantiate the generic $TimeTriggeredDesolve$ model by replacing the generic continuous variable $plantV$ by that or those associated with the case study. If the case study includes several continuous variables, it is necessary to define a set of parameters with the same cardinality as the set of continuous variables. The function $B_desolve$ is then instantiated by the specific parameters of the modeled case study. We make the assumption that the safety

property is in a conjunctive normal form ($\bigwedge_{i=1..n} p_i$) and that, for each formula p_i , the following elements are specified: $event_trig_i$, $safe_i$, $safeEpsilon_i$ and a set of evade values $evade_values_i$ for $ctrlV$. In that case, the instantiation consists in valuing the set $PROP$ and the different constants as follows where $X \in \{event_trig, safe, safeEpsilon, evade_values\}$:

$$PROP = \bigcup_{i=1..n} \{p_i\}, \quad prop_X = \bigcup_{i=1..n} \{p_i \mapsto val_i\}$$

The safety property represented by the formula $prop$ also needs to be instantiated in the specific model (see Section VI).

V. A TOOL FOR SUPPORTING THE APPROACH

To make our approach workable, we built a new RODIN plug-in, called *SageMath* plug-in, that interfaces the RODIN platform with SAGEMATH solver to calculate the solutions of ODEs. Solving ODEs is needed for proving the safety property and the satisfiability of a guard removed in a refinement. In other words, during the proof of a PO, SAGEMATH needs to be called on each term $B_desolve(\dots)$ or $B_desolve_rk4(\dots)$ in order to replace it by the solution of the corresponding ODE.

The use of the SAGEMATH plug-in follows the 3-steps general process: (1) calling SAGEMATH from RODIN, (2) solving differential equations and (3) using the result returned in RODIN (see Figure 9). In the first step, an input field that allows calling SAGEMATH from RODIN appears automatically when the current PO contains the terms $B_desolve$ (resp. $B_desolve_rk4(\dots)$). The second step consists in calling manually a predefined script generated systematically from the function $B_desolve(\dots)$ (resp. $B_desolve_rk4(\dots)$). The user must generate a specific SAGEMATH script according to the structure and the nature of the differential equation to be solved. The last step consists in manually translating the result of SAGEMATH according to EVENT-B syntax. The user must use the theory of reals to translate the result and add it as an hypothesis to prove the current PO. The description of the different stages that constitute the main scenario use of the SageMath plug-in can be downloaded from <https://github.com/CPSsWithEventB/Main/blob/main/README.md>. Hereafter, we describe each step.

A. Calling SAGEMATH from RODIN (Step1)

To call SAGEMATH from RODIN, a button called *sage* has been added in the proof window using an Eclipse plug-in. The button is made available on a hypothesis/goal that contains the term $B_desolve$ (resp. $B_desolve_rk4(\dots)$) as shown by Figure 10.

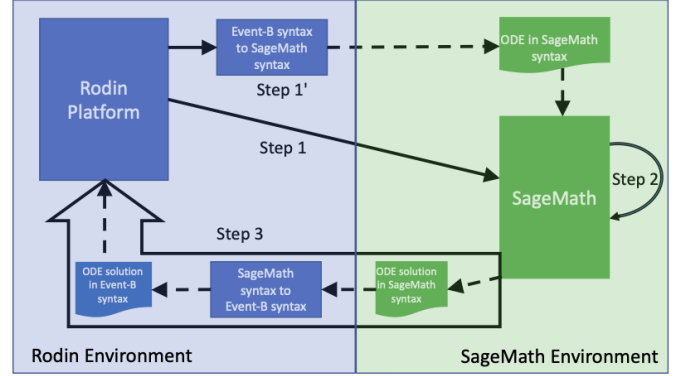

Fig. 9. The general process

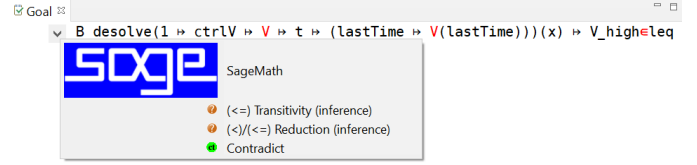

Fig. 10. Calling SAGEMATH from RODIN

To develop a RODIN plug-in, Eclipse provides a set of Java interfaces. These interfaces are intended to be implemented according to the goal of the plug-in. To implement the *SageMath* plug-in using Eclipse IDE, we define the following Java classes: *SageTacticProvider*, *SageApplication* and *SageTactic*.

1) *SageTacticProvider Class*: this Java class implements the method *getPossibleApplications* to check the presence of the term $B_desolve$ (resp. $B_desolve_rk4(\dots)$) in each proof obligation and returns an instance of the *SageApplication* class. Function *getPossibleApplications* uses two main predicates, *pred*, a local variable, and *hyp*, a parameter of the function. *pred* takes as value *hyp* if this latter is not null or the current proof obligation otherwise. If the tags, the left and right parts of the formula *pred*, are equal to those of the predicate that contains $B_desolve$ (resp. $B_desolve_rk4(\dots)$), we return the list of tactics that can be applied as a list of instances of *SageApplication* or null otherwise. This is repeated for each node of the proof tree.

2) *SageTactic Class*: this Java class implements the *apply()* method that creates a process for calling SAGEMATH. Function *apply()* contains all the instructions that will be applied when calling SAGEMATH. The process for calling SAGEMATH is created using the predefined Java class *Process* and provides the

path of the executable file of SAGEMATH to the predefined Java class *ProcessBuilder*. The Java class *ProcessBuilder* can be used to call external applications thanks to the *start()* method and the Java class *Process* can be used to create new system processes.

3) *SageApplication Class*: this Java class establishes the link between the checking of the presence of the function *B_desolve* (resp. *B_desolve_rk4(...)*) in the current proof obligation and the call to SAGEMATH. It implements in particular two methods:

- *getHyperlinkLabel()*: allows to display the button *sage* in the proof window.
- *getTactic()*: allows to create an instance of the class *SageTactic* to execute the *apply()* method.

B. Solving ODEs in SAGEMATH (Step1' and Step2)

In Steps 1' and 2, the ODE is resolved. Step 1' is viewed as a preliminary step of 1. It consists in systematically generating a SAGEMATH script from the EVENT-B functions *B_desolve* and *B_desolve_rk4(...)*, with all the parameters necessary to execute the SAGEMATH predefined functions *desolve* and *desolve_rk4*. In such a script, the differential equation must be expressed depending on the controlled variable *ctrlV* that links the continuous and the discrete parts of an hybrid system. A script is executed in SAGEMATH using the following command: *load('scriptName.sage')*. The script below is generated from the formula $B_desolve(1 \mapsto ctrlV \mapsto plantV \mapsto t \mapsto (lastTime \mapsto plantV(lastTime)))(x)$. It solves a differential equation $plantV' = ctrlV$, where (see Figure 11):

- Statement 1 is generated using the second parameter of *B_desolve* and it specifies the right part of the ODE $plantV' = ctrlV$.
- Statement 2 is generated using the forth parameter of *B_desolve* and it specifies the definition of the independent variable *t*.
- Statement 3 is generated using the third parameter of *B_desolve* and it specifies the definition of the continuous variable represented by *plantV*. The definition of this variable must always be after the definition of the independent variable.
- Statement 4 is generated using the first part of the parameter that specifies the initial conditions and it represents the last progression of time from which we calculate the values of the continuous variable.
- Statement 5 represents the call to the SAGEMATH predefined function *desolve*. The first parameter of this function is generated using the first, second and third parameters of *B_desolve*. The

```

1: ctrlV = var('ctrlV')
2: t = var('t')
3: plantV = function('plantV')(t)
4: lastTime = var('lastTime')
5: eq = desolve(diff(plantV,t,1) ==
ctrlV,dvar = plantV,ivar = t,ics =
[lastTime,plantV(lastTime)])
6: o = open('sageresult.txt','w')
7: o.write(str(eq))
8: o.close()

```

Fig. 11. *B_desolve* script

second, third and forth parameters are generated respectively using the third, forth and last parameters of *B_desolve*.

- Statements 6-8 generate a text file, named "sageresult.txt", which stores the result of the differential equation specified by *eq* in Statement 5.

C. Using SAGEMATH Results in RODIN (Step3)

In Step 3, the term *B_desolve()* is replaced by the result returned by SAGEMATH and stored in a text file. For that purpose, the predicate ($B_desolve() = sol'$) is added as an additional hypothesis in the current PO, where *sol'* is a rewritten of *sol* according to the syntax of the theory of reals. Basically, this theory adopts a prefix style by defining a keyword for each operator on the reals like *plus* for addition, *times* for multiplication, etc. So for instance, the formula $ctrlV \times lastTime + plantV(lastTime)$ is rewritten into $plus(times(ctrlV \mapsto lastTime) \mapsto plantV(lastTime))$.

VI. APPLICATION

To demonstrate the feasibility of our approach we have applied it on several frequently CPS case studies like the following ones:

- The *Stop Sign* System whose objective is to stop a car before a stop signal *SP*. The control strategy is to adjust the velocity of the car by accelerating or braking. The continuous behavior of this system is modeled by the position *p* and the velocity *v* of the car, as well as its acceleration *a*. This continuous behavior evolves according to two linear ODEs, $\frac{dp}{dt} = v(t)$ and $\frac{dv}{dt} = a$.
- The *Hybrid Water Tank* System whose objective is to maintain the water level between a high level *V_high* and a low level *V_low* with $0 < V_low < V_high$. The system includes a tank, a pump to fill the tank and a sensor to get the

level of the water. The water level is specified by the variable V that evolves according to the flowing linear ODEs, $\frac{dV}{dt} = f_{in}$ when the pump is activated and $\frac{dV}{dt} = -f_{out}$ otherwise. The pump is activated (resp. disabled) to fill (resp. empty) the water tank by f_{in} (resp. $-f_{out}$) as long as the property $V < V_{high}$ (resp. $V > V_{low}$) is true.

These case studies are didactic and quite representative of linear hybrid systems that admit exact solutions (polynomial ODE solutions). The continuous behavior of the *Stop Sign* case study is represented by two state variables p and v while that of the *Water Tank* is represented by a single state variable V . Moreover, the *Stop Sign* case study is represented by three different modes of control, *Accelerating*, *Braking* and *Stopped*, that require a single safety envelope. The system can enter state *Accelerating* when the car is very far from the stop signal SP . State *Braking* is entered when the car is very close to the stop signal SP . The state *Stopped* is entered when the car is stopped i.e $v = 0$ (consequently $a = 0$) presumably right before signal SP . In the other hand, the *Water Tank* case study is composed of two modes and when its controller enter one of these two modes the other one is considered as an evade mode which requires the use of two safety envelopes. This diversity will allow us to properly illustrate the use of our generic approach.

For the *Water Tank* case study, we chose to directly instantiate the generic model *TimeTriggeredDesolve* in order to use the interface between RODIN and SAGEMATH to solve the associated ODEs. For the *Stop Sign* case study, we chose to start by modeling the controlled system by refining the generic *EventTriggered* model. The associated *Stop Sign EventTriggered* model will then be refined by a *Stop Sign TimeTriggered* model in which we directly model the solutions of the associated ODEs without using the function $B_{desolve}$. The whole EVENT-B specification can be downloaded from <https://github.com/CPSsWithEventB/Main/blob/main/README.md>. In this paper, we present in details the modeling of the *Water Tank*.

A. The Modeling of the Water Tank System

To model the *Water Tank* case study using our approach, we follow the schema depicted by Figure 12. The instantiation starts by directly refining the generic model *TimeTriggeredDesolve_M* to obtain the model *WaterTank_M* that sees [3] the context *WaterTank_Ctx*. The safety property is expressed in a conjunctive normal form ($V_{low} \leq V \wedge V \leq V_{high}$).

So the context *WaterTank_Ctx* contains the following elements³:

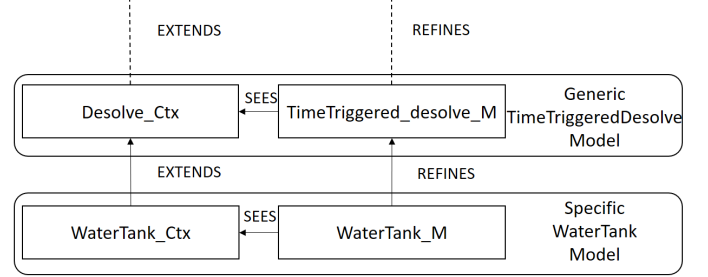

Fig. 12. Architecture of the EVENT-B model of the water tank system

```

PROP={p1, p2}
prop_event_trig={p1 ↦ (λ V ↦ t1 ↦ ctrlV · V ∈ ℝ ∧
    ctrlV × t1 ∈ ℝ | bool(V + ctrlV × t1 ≥ V_low)),
p2 ↦ (λ V ↦ t1 ↦ ctrlV · V ∈ ℝ ∧ ctrlV ∈ ℝ |
    bool(V + ctrlV × t1 ≤ V_high))}
prop_safe={p1 ↦ (λ V ↦ ctrlV · V ∈ ℝ ∧ ctrlV ∈ ℝ |
    bool(V > V_low)),
p2 ↦ (λ V ↦ ctrlV · V ∈ ℝ ∧ ctrlV ∈ ℝ |
    bool(V < V_high))}
prop_safeEpsilon={p1 ↦ (λ V ↦ ctrlV · V ∈ ℝ ∧ ctrlV ∈ ℝ |
    bool(V + (ctrlV × epsilon) > V_low)),
p2 ↦ (λ V ↦ ctrlV · V ∈ ℝ ∧ ctrlV ∈ ℝ |
    bool(V + (ctrlV × epsilon) < V_high))}
prop_evade_values={p1 ↦ {f_in}, p2 ↦ {-f_out}}

```

Machine *WaterTank_M* defines the invariants of Figure 13. Invariant **inv1** is defined to replace the generic continuous variable $plantV$ by the specific one represented by the water level V . Invariant **inv2** specifies the possible values of the variable $ctrlV$. Invariant **inv3** models the safety property using the function $prop \in \mathbb{R} \rightarrow \text{BOOL}$ where the formula $prop(V(x))$ is defined in the context *WaterTank_Ctx* by $V(x) \leq V_{high} \wedge V(x) \geq V_{low}$.

inv1: $plantV = V \wedge ran(V) \subseteq \mathbb{R}$
inv2: $ctrlV \in \{f_{in}, -f_{out}\}$
inv3: $\forall x \cdot x \in dom(V) \Rightarrow prop(V(x)) = TRUE$

Fig. 13. Invariant of the water tank system

The event *Plant*, of the generic machine *TimeTriggeredDesolve_M* is refined by replacing the generic parameters of the function $B_{desolve}$ by those related to the ODEs: $\frac{dV}{dt} = f_{in}$ if the pump is *On* and $\frac{dV}{dt} = -f_{out}$ otherwise (see Figure 14). These ODEs are expressed in the function $B_{desolve}$ as follows: $B_{desolve}(1 \mapsto ctrlV \mapsto V \mapsto t \mapsto (lastTime \mapsto$

³ $bool(P)$ gives the boolean value of the predicate P .

<p><i>Plant</i> REFINES <i>Plant</i> ANY <i>lastTime, plant1</i> WHERE grd1: $exec = plant$ grd2: $lastTime \in \mathbb{R}^+ \wedge dom(V) = [0, lastTime]$ grd3: $plant1 = B_desolve(1 \mapsto ctrlV \mapsto V \mapsto t \mapsto (lastTime \mapsto V(lastTime)))$ grd4: $ode(f_evol_plantV(ctrlV), plant1(t), t) \in DE$ grd5: $Solvable([0, t] - dom(V), ode(f_evol_plantV(ctrlV), plant1(t), t))$ grd6: $AppendSolutionBAP(ode(f_evol_plantV(ctrlV), plant1(t), t), [0, t] - dom(V), [0, t] - dom(V), plant1(t), t))$ THEN act1: $V := V \Leftarrow plant1$ act2: $exec := ctrl$ END</p>	<p>inv4: $\forall x \cdot x \in PROP \wedge ctrlV \notin prop_evade_values(x) \wedge exec = prg \Rightarrow (prop_safeEpsilon(x))(V(t) \mapsto ctrlV) = TRUE$</p> <p>inv5: $\exists t1 \cdot t1 \in RRealPlus \wedge minus(t \mapsto t1) \mapsto epsilon \in leq \wedge dom(V) = Closed2Closed(Rzero, t1) \wedge exec \neq plant \Rightarrow t1 = t \wedge exec = plant \Rightarrow t \mapsto t1 \in gt \wedge (\forall x \cdot x \in PROP \wedge ctrlV \notin prop_evade_values(x) \wedge exec = plant \Rightarrow (prop_safeEpsilon(x))(V(t1) \mapsto ctrlV) = TRUE)$</p>
---	---

Fig. 14. The *Plant* event associated to the water tank system

$V(lastTime)$), where the integer 1 denotes the degree of both ODEs, $ctrlV$ is the controlled variable, V represents the dependent variable for which we calculate the values over the time t that denotes the independent variable, and $lastTime$ and $V(lastTime)$ represent respectively the initial values of the time t and the value of continuous variable V at the instant $lastTime$.

B. Correctness of the specification of the Water Tank

TABLE III
 RODIN PROOF STATISTICS FOR THE SMART HEATING SYSTEM

Specific_Models	Total	Automatic	Interactive
WaterTank_M	102	40	62

Machine *WaterTank_M* generates 102 POs, 39% of them are automatically discharged. Like for the generic models, the POs related to the guard feasibility and well-definedness have been interactively discharged under RODIN thanks to several provers like SMT and AtelierB provers but also inference rules described in the RODIN theory that implements reals. The use of these inference rules made the proof activity longer since they are not automatically applied even on simple examples like the transitivity rule.

To discharge the POs related to the guards feasibility and well-definedness, we needed to add invariants that translate implicit properties on the system (see Figure 15). This invariant specifies that the system is safe if the controller has chosen a value for $ctrlV$ that does not belong to the sets $prop_evade_values(x)$.

Fig. 15. Implicit property on the system

Fig. 16. Preservation of the property during a cycle of ϵ units of time

Moreover, we added an invariant which ensures that before executing the physical part, the safety property is satisfied during the period $epsilon$ (see Figure 16).

The most important part in the proof phase is the one concerning the safety property specified using the invariant *inv3*. RODIN generated for this invariant the PO of Figure 17 for removing the *grd8* defined in Section IV-E. This PO is obtained by replacing *plant1* in $V := V \Leftarrow plant1$ by $B_desolve(1 \mapsto ctrlV \mapsto V \mapsto t \mapsto (lastTime \mapsto V(lastTime)))$ (see *grd3* of event *Plant*). To discharge this PO, we call SAGEMATH to obtain the exact solution of the related ODE.

We must then replace the function $B_desolve(...)$ with the solution returned by the call to SAGEMATH from RODIN. This solution is obtained by replacing the generic variable $plantV$ by V in the script of Figure 11 as depicted by Figure 18.

Let us remark that for the non-linear ODE, the proof of the safety property is achieved by assuming the monotonicity of the function returned by $desolve_rk4$ on the interval $[lastTime, t]$. For that purpose, we have to prove the following property on the returned function to state that it is increasing or decreasing:

$$\forall tt \cdot tt \in [lastTime, t] \Rightarrow (plant1(tt) \geq plant1(lastTime) \wedge plant1(tt) \leq plant1(t)) \vee (plant1(tt) \leq plant1(lastTime) \wedge plant1(tt) \geq plant1(t))$$

$$B_desolve(1 \mapsto ctrlV \mapsto V \mapsto t \mapsto (lastTime \mapsto V(lastTime)))(x) \leq V_high \wedge B_desolve(1 \mapsto ctrlV \mapsto V \mapsto t \mapsto (lastTime \mapsto V(lastTime)))(x) \geq V_low$$

Fig. 17. The PO related to the safety property

```

sage: ctrlV=var('ctrlV')
sage: t=var('t')
sage: V=function('V')(t)
sage: lastTime=var('lastTime')
sage: desolve(diff(V,t)==ctrlV,dvar=V,ivar=t,ics=[lastTime,V(lastTime)])
-ctrlV*lastTime + ctrlV*t + V(lastTime)
sage:

```

Fig. 18. Solving $V' = ctrlV$ in SAGEMATH

Having this property as verified, the proof of a safety property comes down to prove it for the lower and/or the upper bounds.

C. Discussion on the proof activity

From both case studies that we have modeled and verified to prove the feasibility of our approach, the following conclusion can be drawn. The complexity of the application-dependent proofs is proportionate to the number of the terms of the ordinary differential equation solution. In other words, the higher the degree of the ordinary differential equation, the higher the complexity of the proofs: the proofs of the *Stop Sign* case study took more than one week while 2 days were enough for the *Water Tank* case study. We think that the development of an inference engine for the theory that implements the reals would help speed up the proof activity. Such an inference rule would automate the application of some inference rules like reflexivity, transitivity, etc.

VII. CONCLUSION AND FUTURE WORKS

This paper has presented a proof-based approach that uses the EVENT-B refinement technique to model and verify the correctness of CPSs whose behavior is described using ODEs. This approach combines the EVENT-B formal method with the differential equation solver SAGEMATH by modeling and implementing the call to the solver. The approach is supported by a tool, built as a RODIN plug-in, that establishes the bridge between EVENT-B and SAGEMATH.

Our approach can be compared to the approach described in [18] that also proposes a generic modeling of *Event-* and *Time-Triggered* systems using dRL. The differential refinement logic dRL requires mastering the syntax of other tools to validate the proof phase. For example, it requires mastering the syntax of KeYmaera and KeYmaera X to prove safety properties of the *EventTriggered* model. Unlike dRL, our approach uses the end-to-end formal method EVENT-B to take advantage of its supported tools and its refinement strategy, along with the coupling RODIN and SAGEMATH.

To cope with the complexity of the system, the built EVENT-B specification consists of four generic models: *System* model that represents the continuous aspects of CPSs, *EventTriggered* model that specifies the interactions between the discrete and the continuous parts of CPSs, *TimeTriggered* model that specifies the discrete time of the discrete part of CPSs and *TimeTriggeredDesolve* that introduces a function to model the call to a DE solver, called either *B_desolve* when treating linear ODEs and *B_desolve_rk4* when treating nonlinear ODEs.

The proposed approach was successfully applied on several case studies like the water tank system presented in this paper but also those with multiple continuous variables such as the *Stop Sign* case study <https://github.com/CPSsWithEventB/Main/blob/main/README.md>. We admit that the chosen case study is a simple hybrid system with a linear ODE but it served us to describe the different steps for applying our generic approach. Using SAGEMATH, we can deal with more complex ODEs as we showed by modeling the function *desolve_rk4* which solves nonlinear ODEs. Moreover, the work described in this paper presents a first step that will facilitate the treatment of complex hybrid systems using EVENT-B. Without solving ODEs, our models were abstract and did not allow proving the safety properties of hybrid systems. As future work, we plan to apply our approach on more complex case studies.

REFERENCES

- [1] DISCONT ANR Project, <https://discont.loria.fr>.
- [2] L. Perko, *Differential Equations and Dynamical Systems*, Vol. 7, Springer Science & Business Media, 2013.
- [3] J.-R. Abrial, *Modeling in Event-B: System and Software Engineering*, Cambridge University Press, 2010.
- [4] H. Kopetz, *Event-Triggered Versus Time-Triggered Real-Time Systems*, in: *Operating Systems of the 90s and Beyond*, Springer, 1991, pp. 86–101.
- [5] P. Zimmermann, A. Casamayou, N. Cohen, G. Connan, T. Dumont, L. Fousse, F. Maltey, M. Meulien, M. Mezzarobba, C. Pernet, et al., *Computational Mathematics with SageMath*, SIAM, 2018.
- [6] M. Afendi, R. Laleau, A. Mammar, *Modelling hybrid programs with event-b*, in: *Rigorous State-Based Methods: 7th International Conference, ABZ 2020, Ulm, Germany, May 27–29, 2020, Proceedings*, Springer, 2020, pp. 139–154.
- [7] M. Butler, I. Maamria, *Mathematical Extension in Event-B through the Rodin Theory Component* (2010).
- [8] S. Wolfram, *The Mathematica Book*, 5th edn. Wolfram Media, Champaign (2003).
- [9] T. A. Henzinger, P. Ho, H. Wong-Toi, HYTECH: A model checker for hybrid systems, *Int. J. Softw. Tools Technol. Transf.* 1 (1-2) (1997) 110–122. doi:10.1007/s100090050008. URL <https://doi.org/10.1007/s100090050008>

- [10] G. Frehse, C. L. Guernic, A. Donzé, S. Cotton, R. Ray, O. Lebeltel, R. Ripado, A. Girard, T. Dang, O. Maler, Spaceex: Scalable verification of hybrid systems, in: G. Gopalakrishnan, S. Qadeer (Eds.), *Computer Aided Verification - 23rd International Conference, CAV 2011, Snowbird, UT, USA, July 14-20, 2011. Proceedings*, Vol. 6806 of *Lecture Notes in Computer Science*, Springer, 2011, pp. 379–395. doi: 10.1007/978-3-642-22110-1_30. URL https://doi.org/10.1007/978-3-642-22110-1_30
- [11] R. Banach, M. Butler, S. Qin, N. Verma, H. Zhu, Core Hybrid Event-B I: Single Hybrid Event-B Machines, *Science of Computer Programming* 105 (2015) 92–123.
- [12] W. Su, J.-R. Abrial, H. Zhu, Formalizing Hybrid Systems with Event-B and the Rodin Platform, *Science of Computer Programming* 94 (2014) 164–202.
- [13] M. Butler, J.-R. Abrial, R. Banach, *Modelling and Refining Hybrid Systems in Event-B and Rodin* (2016).
- [14] G. Dupont, Y. Ait-Ameur, M. Pantel, N. K. Singh, Proof-Based Approach to Hybrid Systems Development: Dynamic Logic and Event-B, in: M. Butler, A. Raschke, T. S. Hoang, K. Reichl (Eds.), *Abstract State Machines, Alloy, B, TLA, VDM, and Z*, Springer International Publishing, Cham, 2018, pp. 155–170.
- [15] A. Platzer, Differential Dynamic Logic for Hybrid Systems, *Journal of Automated Reasoning* 41 (2) (2008) 143–189.
- [16] A. Platzer, J.-D. Quesel, KeYmaera: A Hybrid Theorem Prover for Hybrid Systems (System Description), in: *International Joint Conference on Automated Reasoning*, Springer, 2008, pp. 171–178.
- [17] N. Fulton, S. Mitsch, J.-D. Quesel, M. Völp, A. Platzer, KeYmaera X: An Axiomatic Tactical Theorem Prover for Hybrid Systems, in: *International Conference on Automated Deduction*, Springer, 2015, pp. 527–538.
- [18] S. M. Loos, A. Platzer, Differential Refinement Logic, in: *2016 31st Annual ACM/IEEE Symposium on Logic in Computer Science*, IEEE, 2016, pp. 1–10.
- [19] G. Dupont, Y. A. Ameur, M. Pantel, N. K. Singh, Event-B Refinement for Continuous Behaviours Approximation, in: Z. Hou, V. Ganesh (Eds.), *Automated Technology for Verification and Analysis - 19th International Symposium, ATVA 2021, Gold Coast, QLD, Australia, October 18-22, 2021, Proceedings*, Vol. 12971 of *Lecture Notes in Computer Science*, Springer, 2021, pp. 320–336.