

# Mixing data and knowledge for modeling and control of building energy systems

**Benoit DELINCHANT**

*Grenoble Electrical Engineering Lab  
Grenoble-INP*



DESCARTES  
**Decision-making in  
Critical Urban Systems**

**SINERGIE**

**French-Singaporean research network programme on Renewable Energy**

**Monday, 6 November 2023**

**Session-03 - Smart Buildings and Smart Cities**

**NTU Reality Theatre - Research Techno Plaza (RTP)**

**Singapore**



# Outline

## Context and Strategies for Hybridization

### Application to Building modelling

Quang Hùng Nguyen, Benoit Delinchant, Florent Chatelain.  
Machine learning driven parameter identification for grey-box  
thermal modelling for buildings. Building Simulation 2023, Sep  
2023, Shanghai, China

### Application to Building control

Sharath Ram Kumar, Remy Rigo Mariani, Benoit Delinchant,  
Arvind Easwaran, "Towards Safe Model-Free Building Energy  
Management using Masked Reinforcement Learning", ISGT 2023

# Context and Motivations

## District Energy Management

### Energy flexibility at district level

- Management strategies of energy systems :
  - Buildings with/without flexibilities
  - PV (intermittent RES)
  - Storage local/district (bidirectional control)

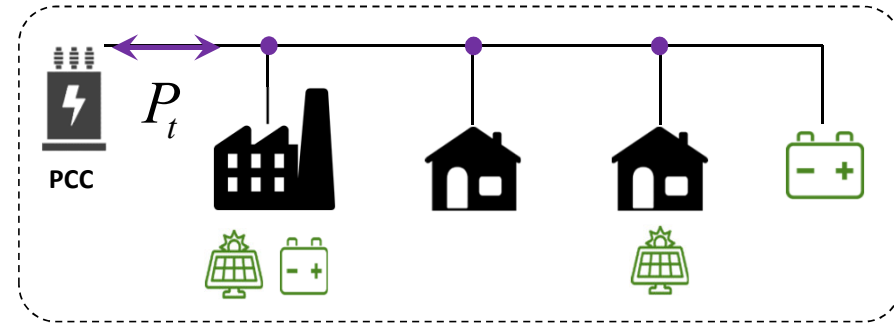

### Different sources of uncertainties :

- Forecast Errors on the input (e.g. RES/occupancy profiles)
- Model Accuracy (e.g. simplification physical laws.)
- Model Parameters (e.g. physical properties not perfectly known.)

**Opportunity to mitigate uncertainties using real time data:**

1. To re-estimate model parameters continuously: **active parameter learning**
2. **reinforcement learning controller hybrid strategies**

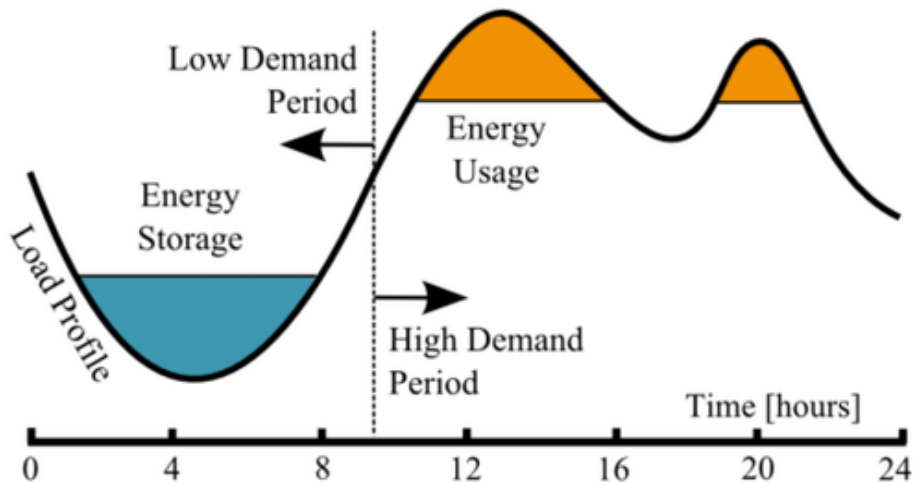

# Hybridization Strategies

## Modeling and Control strategies

### Modeling methodology [PhD Quang Hùng NGUYEN]

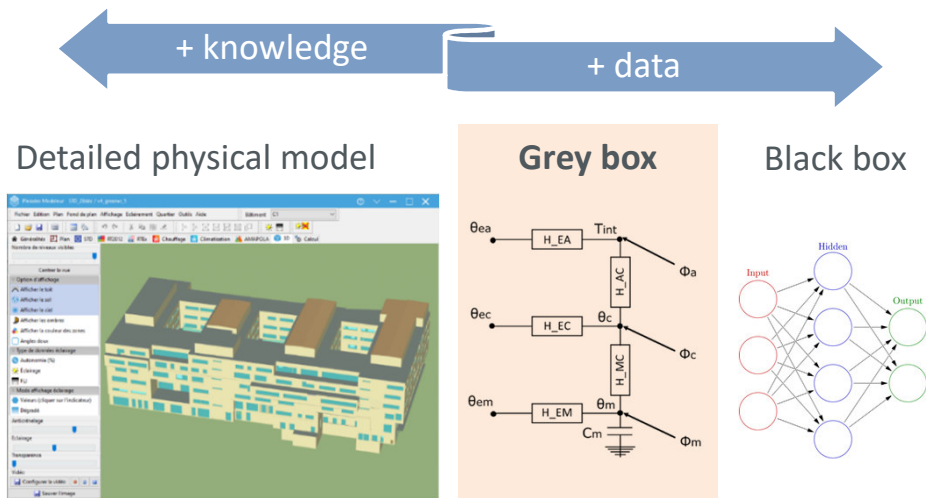

### RC (grey box) models

- **Explainability** from knowledge (extrapolate to new situations not seen in data)
- **Adaptability** from data (to manage lack of knowledge)
- Easy to deploy at district level (RC archetypes)
- Hybrid : Retain **major physical dynamics** while enabling **data-driven parameters learning**

### Control methodology [PhD Sharath RAM KUMAR]

- **Model Predictive Control (MPC)** : find optimal controls based on forecasting of inputs  $w_t$  and the system model  $(f, g)$

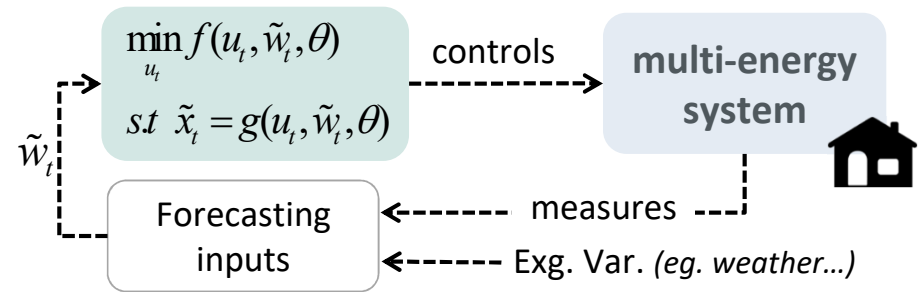

- **Reinforcement learning (RL)** : find optimal policy  $\phi$  of interaction between the controller (agent) and the system (environment)

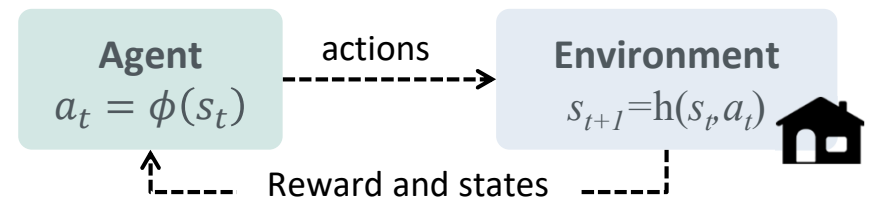

- **Drawback** : need many experiments to learn
- **Hybrid approach** : using model and knowledge to guide learning

# Outline

## Context and Strategies for Hybridization

### Application to Building modelling

Quang Hùng Nguyen, Benoit Delinchant, Florent Chatelain.  
Machine learning driven parameter identification for grey-box  
thermal modelling for buildings. Building Simulation 2023, Sep  
2023, Shanghai, China

### Application to Building control

Sharath Ram Kumar, Remy Rigo Mariani, Benoit Delinchant,  
Arvind Easwaran, "Towards Safe Model-Free Building Energy  
Management using Masked Reinforcement Learning", ISGT 2023

# Building hybrid model

## Data assimilation

### Lumped-parameters physical model

- One zone R2C2 differential equation model

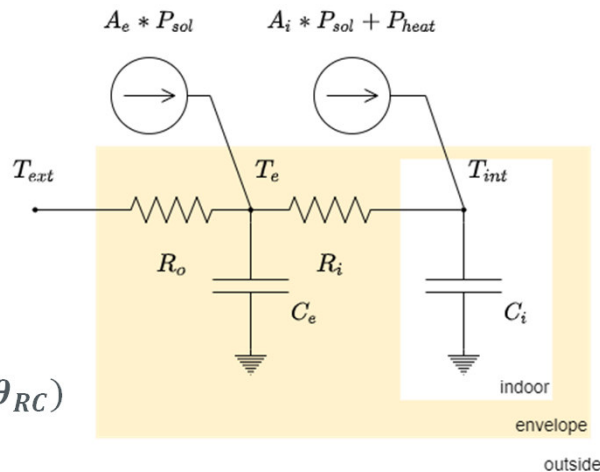

$$\frac{dT_{nodes}}{dt} = f(T_{nodes}, \mathbf{u}, \theta_{RC})$$

$T_{nodes}$ : temperature at nodes

$\mathbf{u}$ : heat fluxes (input)

$\theta_{RC}$ : parameters

### $\theta_{RC}$ parameter identification : solve LS minimization

- Training during one year to catch seasonal variation
- Data are from numerical simulation

## Indoor temperature prediction

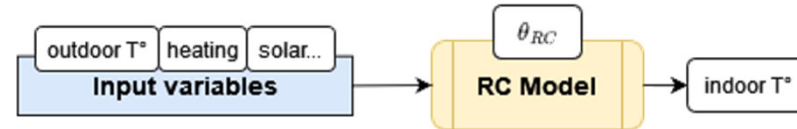

- Prediction error can be important, coming from **modelling hypotheses** and **external factors uncertainties**

### Improvement : tradeoff between complexity and uncertainties

- Increasing model complexity lead to identification failure...

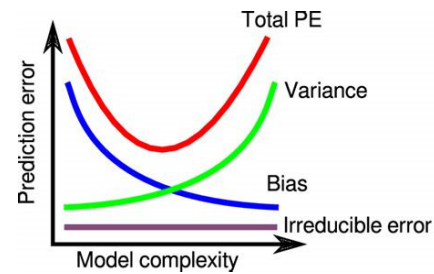

### How to deal with time-varying bias ?

- $\theta_{RC}$  rolling identification [Quan Nguyen-Hong et. al. 2017],
- piecewise constant parameters

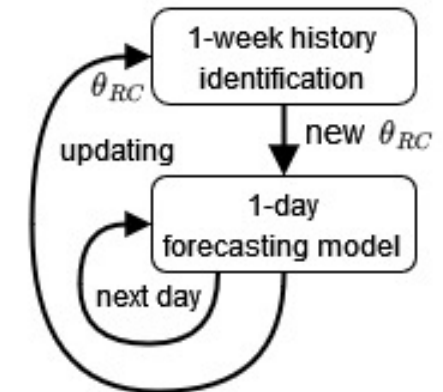

[Quan Nguyen-Hong et. al. 2017], Meta-Optimization and Scattering Parameters Analysis for Improving On Site Building Model Identification for Optimal Operation

## Comparing rolling identification with a machine learning approach

### No optimization during simulation

- Why :
  - to avoid doing non-convex optimization
  - to smooth variation of  $\theta_{RC}$ , filtering bad results
  - to add exogeneous variables
  - to reduce computational cost
  - ...

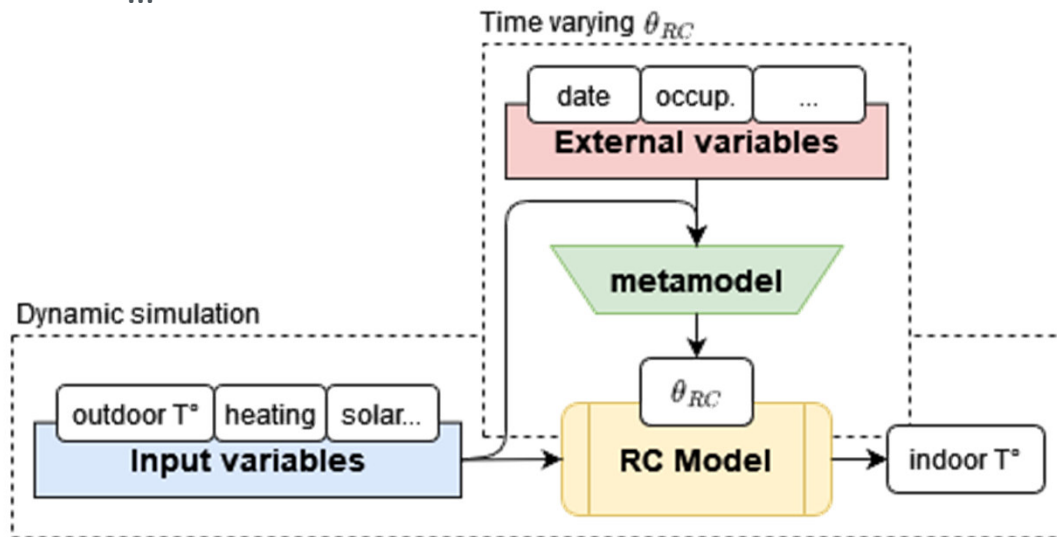

### Replace optimization by a metamodel learnt from past identifications

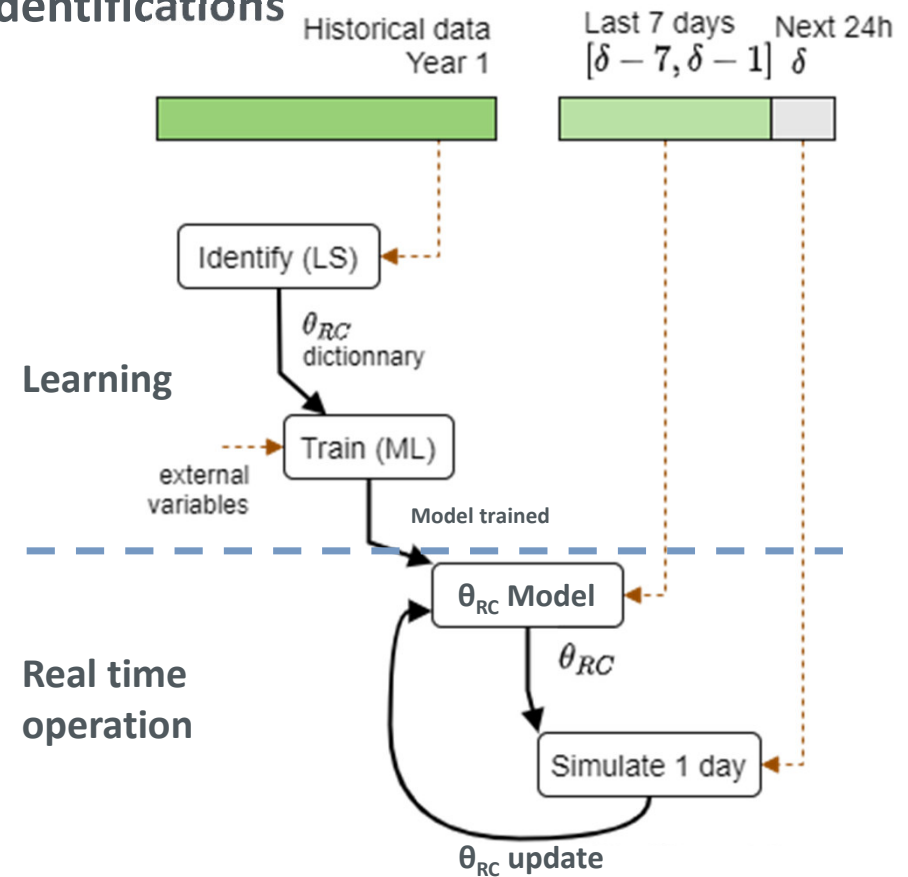

# Results

## Experiment

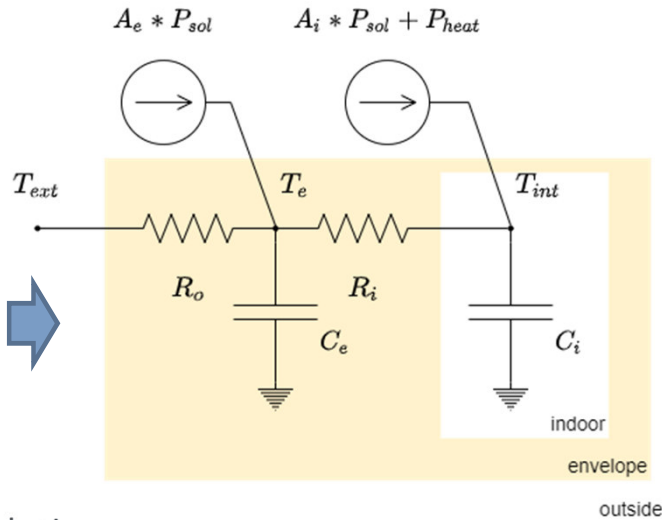

### $\theta_{RC}$ metamodel learning

- **ground truth data** : EnergyPlus simulation
  - 1 year for training, 1 year for testing
- **Identification**: least squared errors of  $T_{int}$  ( $^{\circ}\text{C}$ ) (LS optimization)
  - 7 parameters :  $[R_i, R_o, C_i, C_e, A_i, A_e, T_{e\text{init}}]$
  - Daily value identification from 1 week length history
  - $R^2$  score  $< 0.7$  = removed (marked "x" on graph)
- **$\theta_{RC}$  metamodel** : Linear regression (Ridge)
  - Inputs from RC : time series reduced to statistics (mean and variance)
    - Daily  $\rightarrow 7*2$  features per variable
    - Week  $\rightarrow 1*2$  features per variable
  - Exogeneous variables : *Number of occupants, season of year*

### Daily-varying RC model parameters

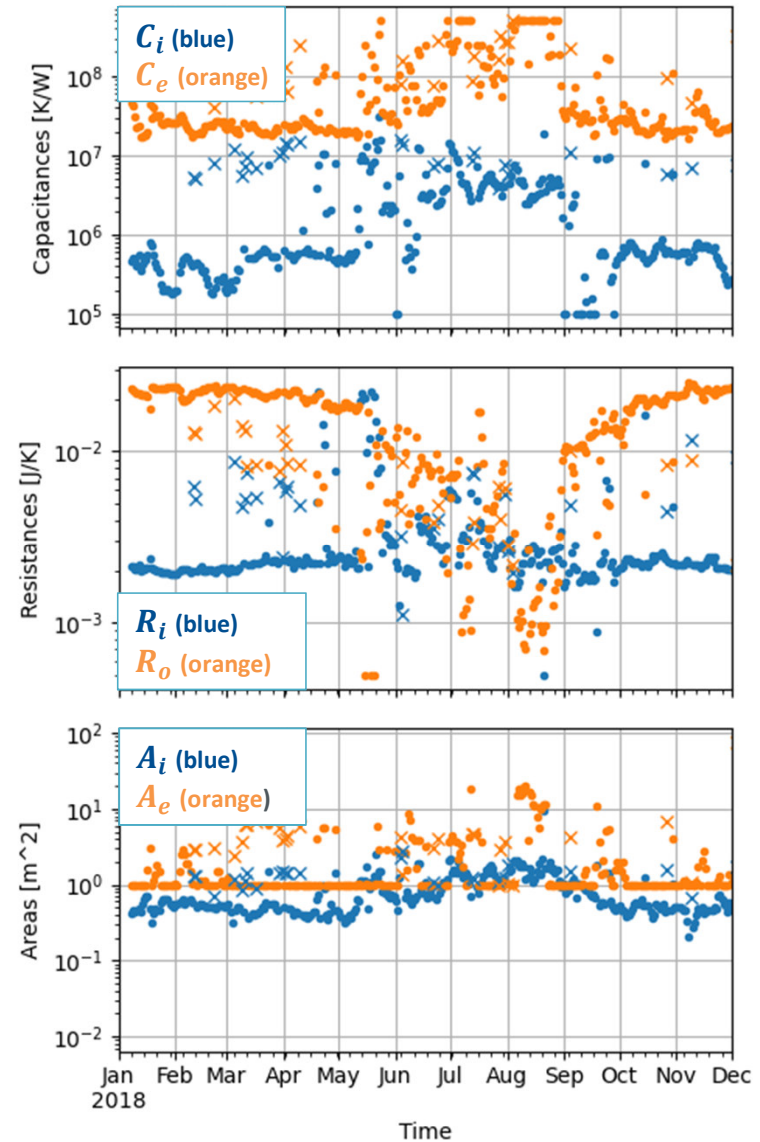



## Performances

**Metrics** : Statistics on Absolute Error of  $T_{int}$   
*mean, standard deviation, max*

### 5 models comparison

1. Constant  $\theta_{RC}$  (1 LS identification for 1 year)  
**time varying  $\theta_{RC}$**  (1-day piecewise cst) :
2. Rolling LS identification (robustness, comp. ress.)
3. Reusing post-treated 1st year  $\theta_{RC}$  (accuracy loss)
4. Ridge meta-model (weakly stats)
5. Ridge meta-model (daily stats)

### Conclusions

- Hybrid physics and ML approach
- Enhanced computation resources and robustness
- Enhanced accuracy by providing exogen. variables.

**METRICS – Indoor temperature (°C)**  
**Absolute Error Statistics**

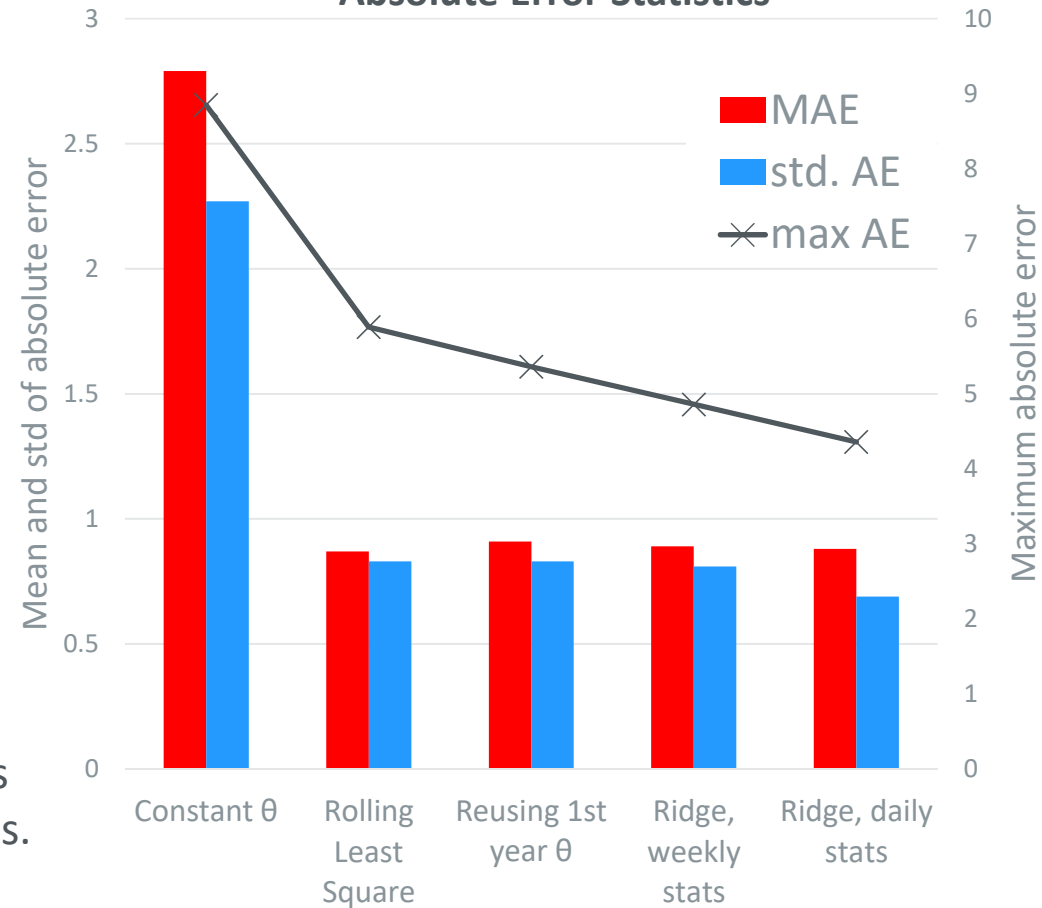

# Outline

## Context and Strategies for Hybridization

## Application to Building modelling

Quang Hùng Nguyen, Benoit Delinchant, Florent Chatelain.  
Machine learning driven parameter identification for grey-box  
thermal modelling for buildings. Building Simulation 2023, Sep  
2023, Shanghai, China

## Application to Building control

Sharath Ram Kumar, Remy Rigo Mariani, Benoit Delinchant,  
Arvind Easwaran, "Towards Safe Model-Free Building Energy  
Management using Masked Reinforcement Learning", ISGT 2023

# Building control

## Energy management system

- **Building energy systems:** solar panels, energy storage and controllable HVAC (heating ventilation air conditioning).
- **Cost/Comfort Trade-off** – minimum electrical bill and max. indoor comfort.
- **Defining an hybrid controller :**
  - Knowledge/Expertise available : Rule-Based-Controller (RBC)
  - Data : power meter at building level

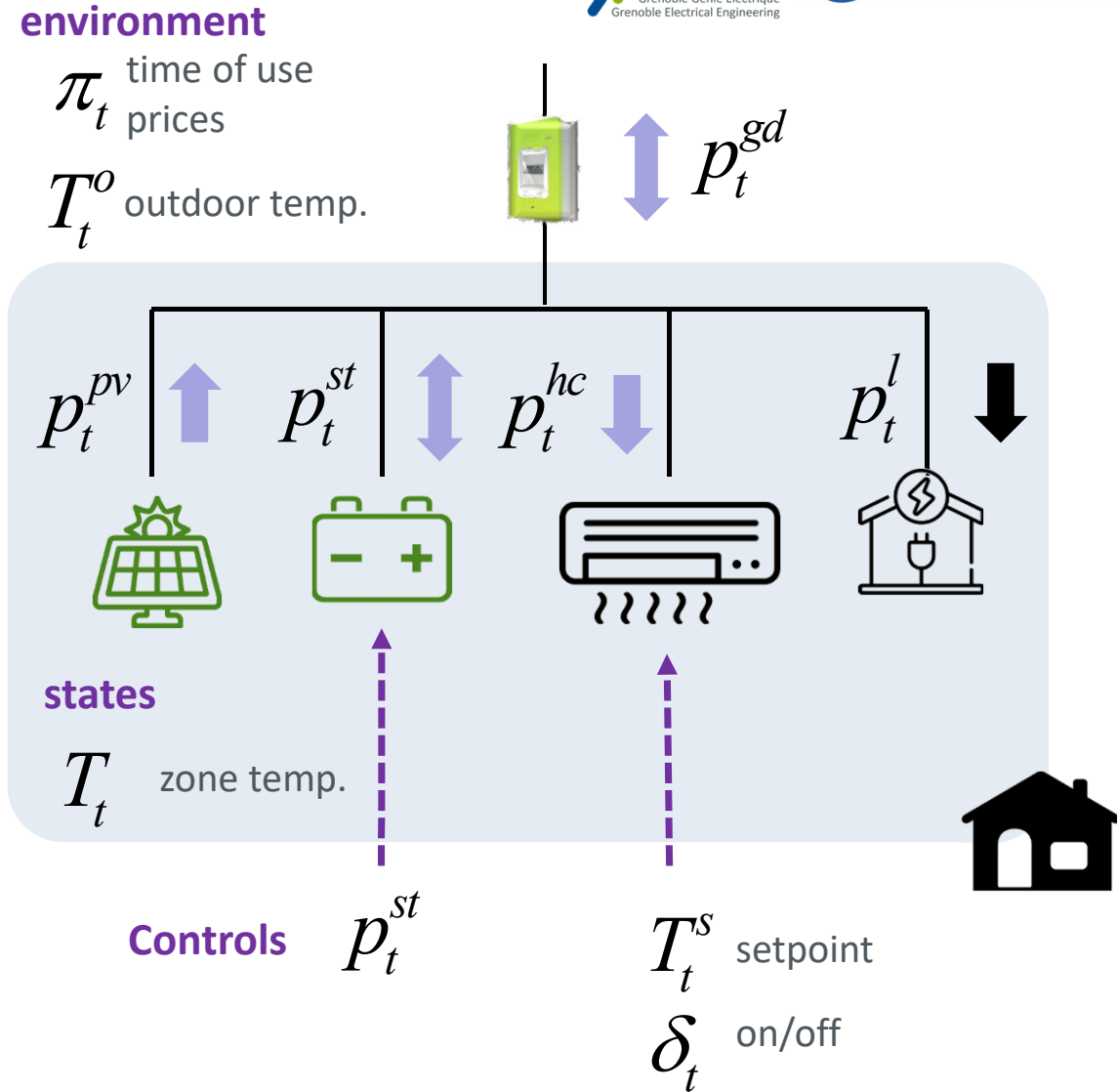

# Learning-Based Controllers

## Deep Reinforcement Learning

### Reference method : Proximal Policy Optimization (PPO)

- **Reinforcement Learning (RL)** is a model free approach of decision making (policy  $\phi$ ) **depending on the actual state  $s_t$**  (Markov Decision Process), in order to **maximize the expected cumulative reward**.
- **PPO** is a policy gradient deep RL method which ensures a **small deviation for each policy update**, and is based on **Actor-Critic** which learn two function approximations:
  - A *policy* that controls how the agent acts (actor)
  - A *value function* to assist the policy update by measuring how good the action taken is

### RL Limitations :

- The learning phase may require many samples in order to capture a good behaviour => **model free approach**
- The exploration may generates “unrealistic” controls regarding the physics of the systems and its constraints => **no knowledge / expertise about the system**

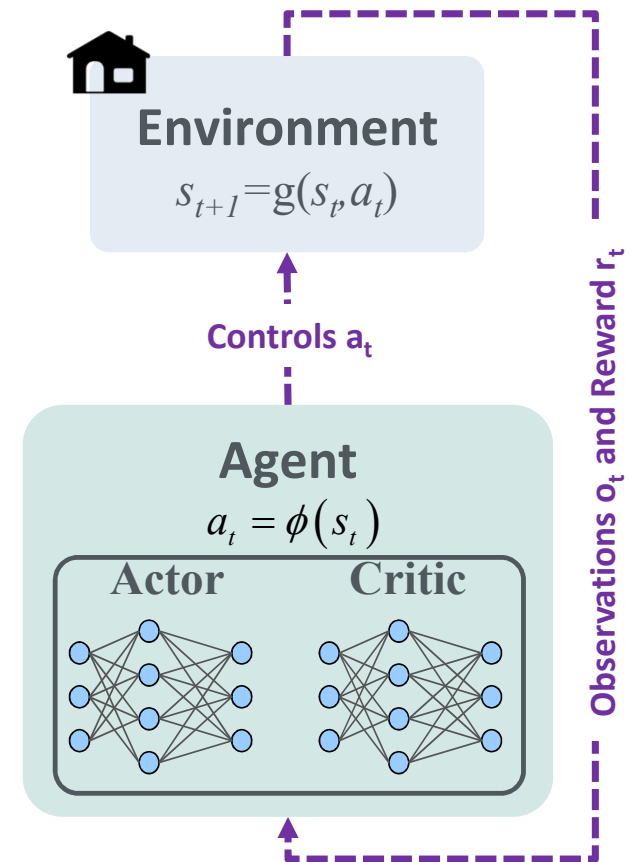

# Learning-Based Controllers

## Problem definition

- State :  $s_t = [h \quad wkday \quad soc_t \quad \pi_t \quad T_{t-1} \quad P_{t-1}^{gd}]$
- Action :  $a_t = [p_t^{st} \quad T_t^s \quad \delta_t]$  continuous or discrete space
- Reward to maximize over time:

$$r_t = r_t^{gd} \times r_t^{hc}$$

$$r_t^{gd} = (a - b \times p_t^{gd} \times \pi_t \times dt)$$

$$r_t^{hc} = (d \times \Delta T_t^2 + e \times \Delta T_t + f)$$

$$\Delta T_t = T_t - T_t^{ref}$$

Rk :  $r_r^{hc}$  is  $< 0$  when  $r_r^{hc} < 0$  and  $r_r^{hc} < 0$

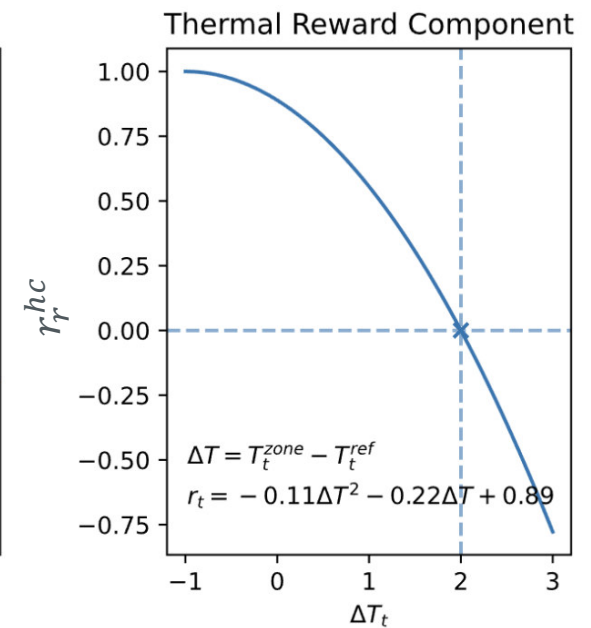
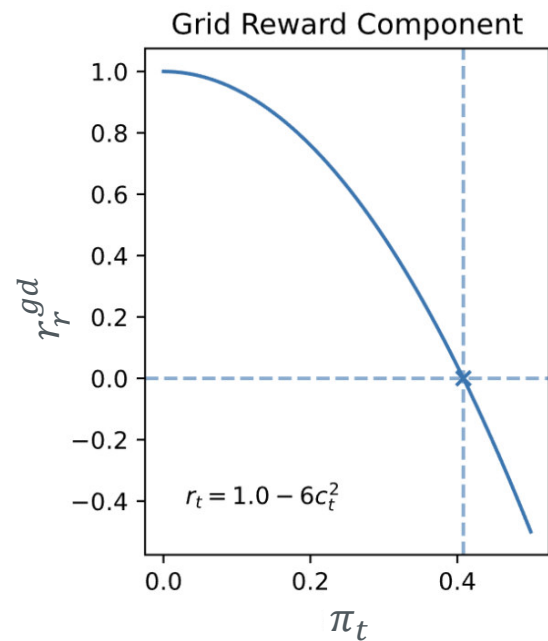
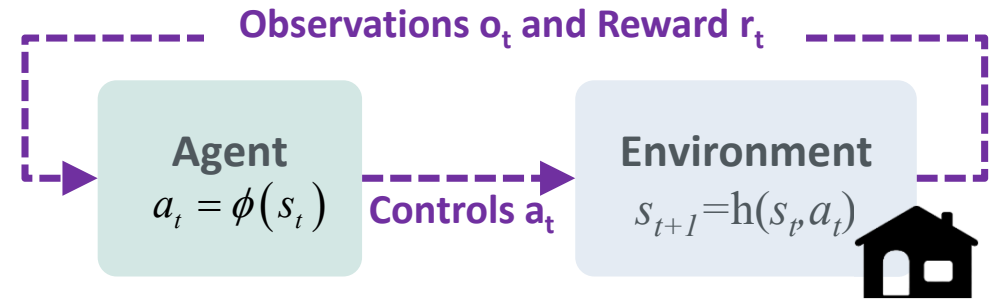

# Learning-Based Controllers

## Strategy 1 : Use knowledge / expertise to pre-train the policy

- **RL Limitation** – The learning phase may require many iterations in order to capture a good behaviour.
- **Behavioural Cloning (BC)** – initialize the controller in an offline mode from Rule Based Controller (RBC) samples : from real environment or applied on a model (eg. RC).

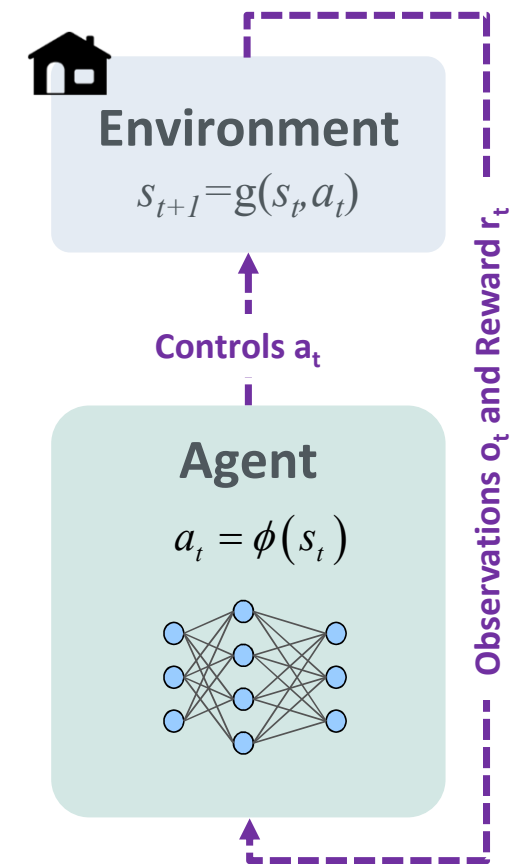
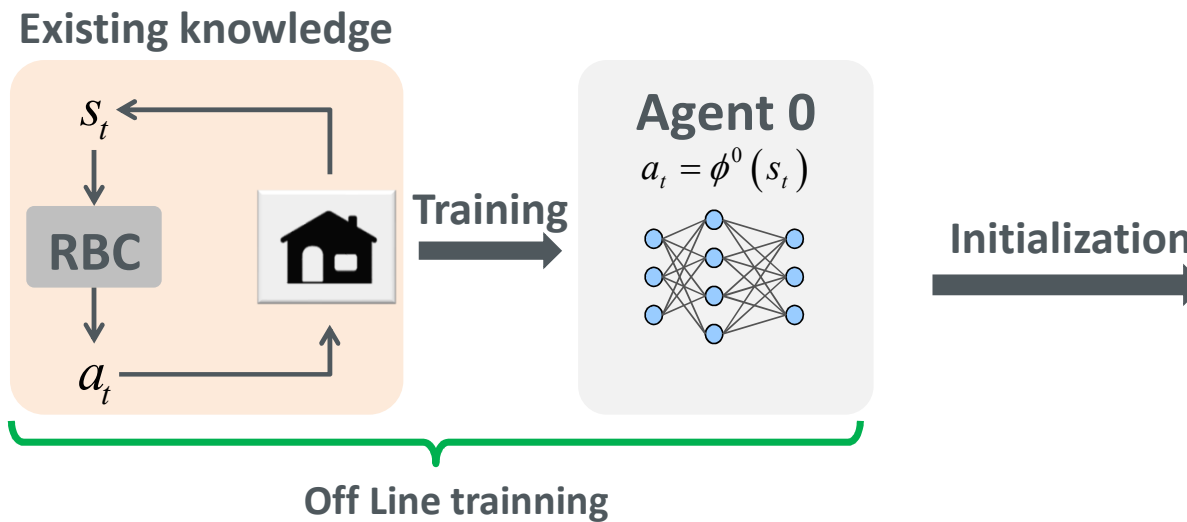



# Learning-Based Controllers

## Strategy 2 : Use knowledge / expertise to avoid bad actions

- **RL Limitation** – In the exploration phase RL may generate “unrealistic” controls regarding the physics of the systems and its constraints.
- **Masked RL (MRL)** – rules to eliminate illogical controls before they are sent to the environment.
  - No charge/discharge beyond limits ( $\text{soc}_t$ )
  - HVAC is forced “ON” if the temperature is outside of the comfort zone
  - ...

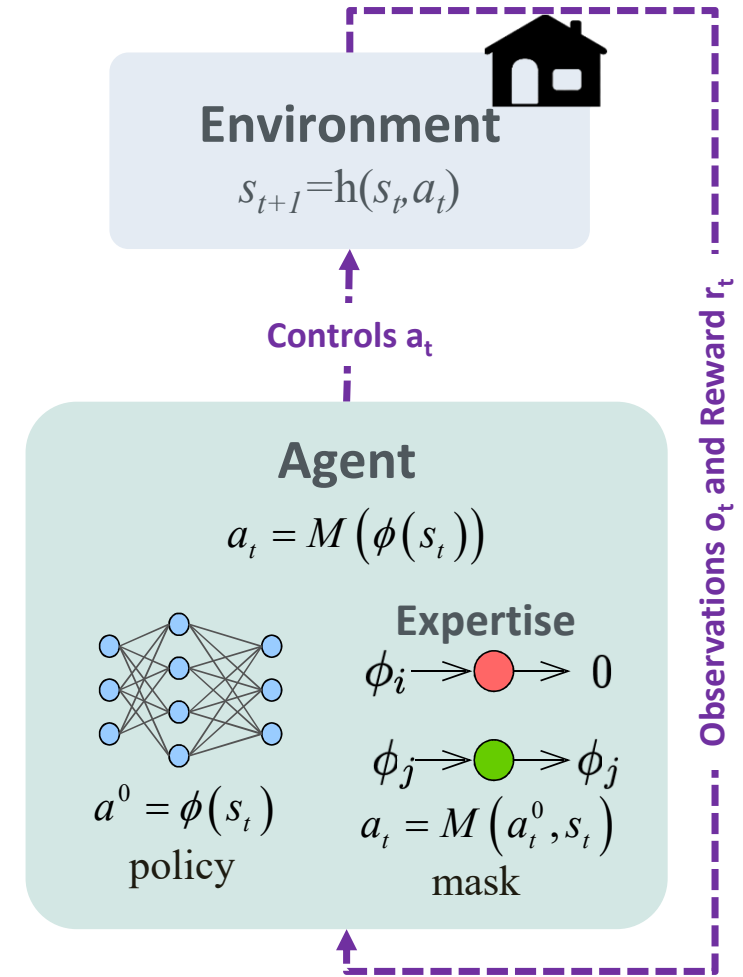

## Four Controllers Investigated :

- Baseline Rule-Based-Controller - **RBC**
- Reinforcement Learning – **RL**
- Behavioural Cloning + RL – **BCRL**
- Masked Reinforcement Learning – **MRL**

**Hyperparameters** for Learning-Based Controllers based on Proximal Policy Optimization (PPO).

	Continuous	Discrete
<b>Learning rate</b>	$2.7e^{-4}$	$2.3e^{-4}$
<b>Discount factor</b>	0.999	0.988
<b>Clip range</b>	0.6	0.7
<b>Episod length</b>	1 day	1 day

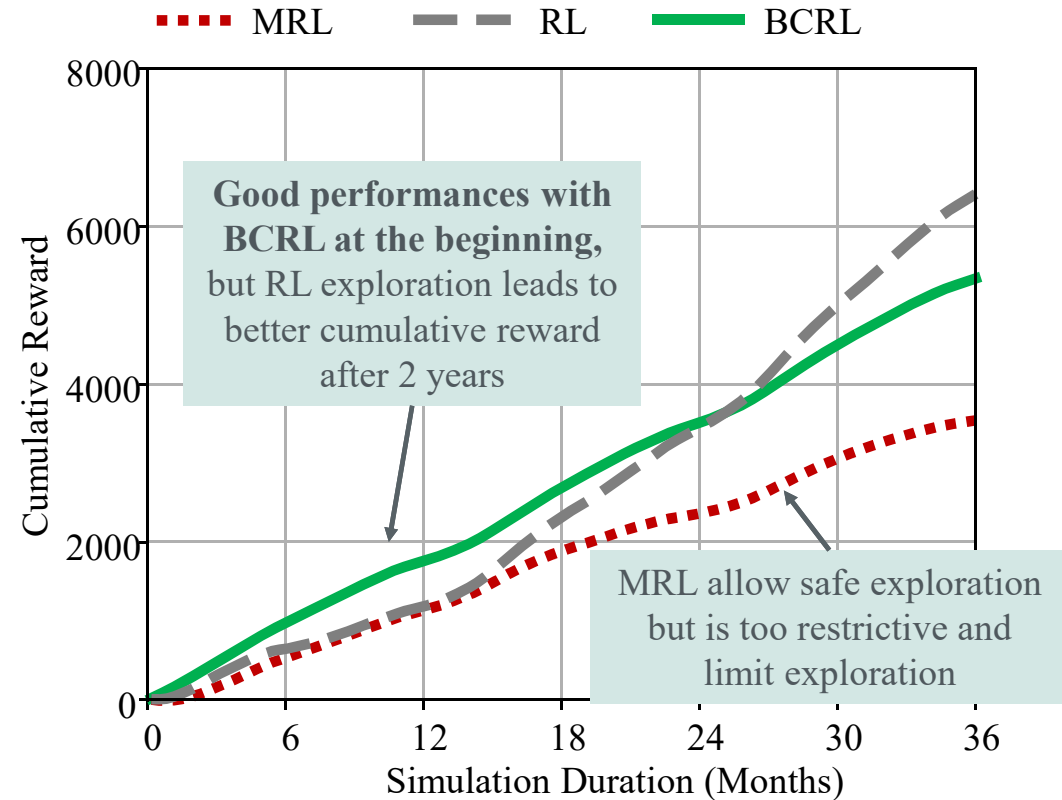



# Results

## Sensitivity to reward function

## Conclusions

Test over different reward functions

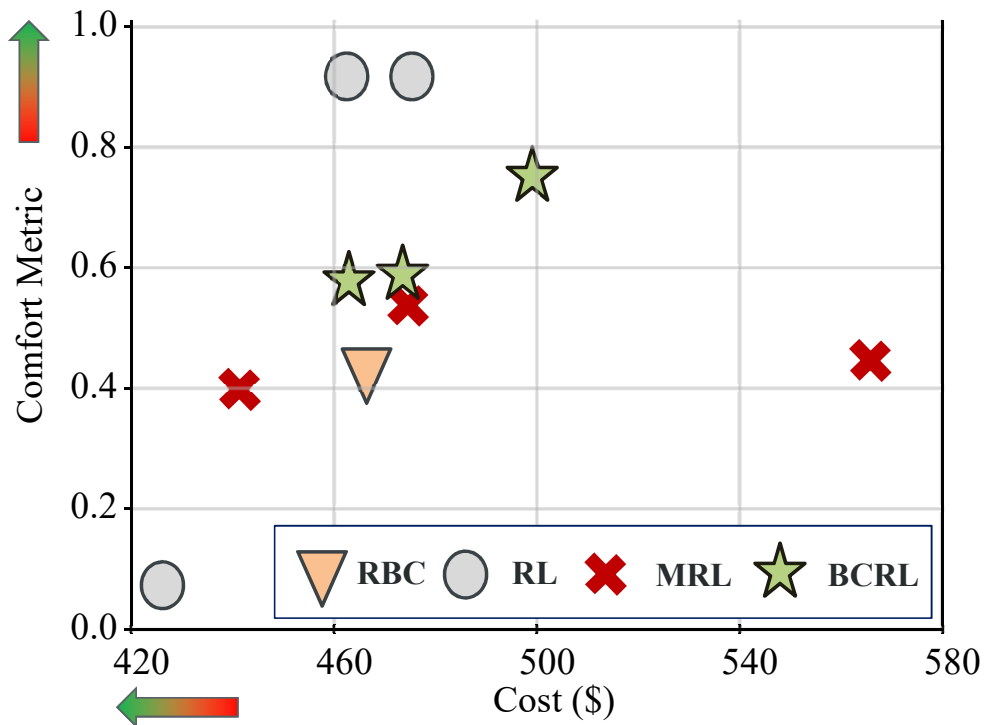

▽ RBC	+ robust low complexity	- suboptimal not adaptive
○ RL	+ No knowledge a priori	- Sensitive to reward / hyperparameters
★ BCRL	+ Fast & Stable training	- Less exploration
✗ MRL	+ Safe exploration	- Less exploration

**RBC** - Baseline Rule-Based-Controller

**RL** - Reinforcement Learning (PPO)

**BCRL** - Behavioural Cloning + RL

**MRL** - Masked Reinforcement Learning

# Conclusions and Future Works

## Mixing data and knowledge for modeling and control of building energy systems

- **Building modeling approach :**
  - Use general/simple physical law (RC)
  - Time varying parameters to catch modelling errors  
 ⇒ reduce by 3 the MAE
  - Train NN instead of continual re-identification  
 ⇒ Increase robustness
  - Tested different models with exogen parameters  
 ⇒ improvements on the error variance
- **Building controller :**
  - RL for adaptation
  - Existing knowledge (RBC) => Pre-training of NN
  - Action masking to avoid illogical control and keep safe exploration  
 ⇒ Always a **balance** between knowledge **exploitation** and **exploration**

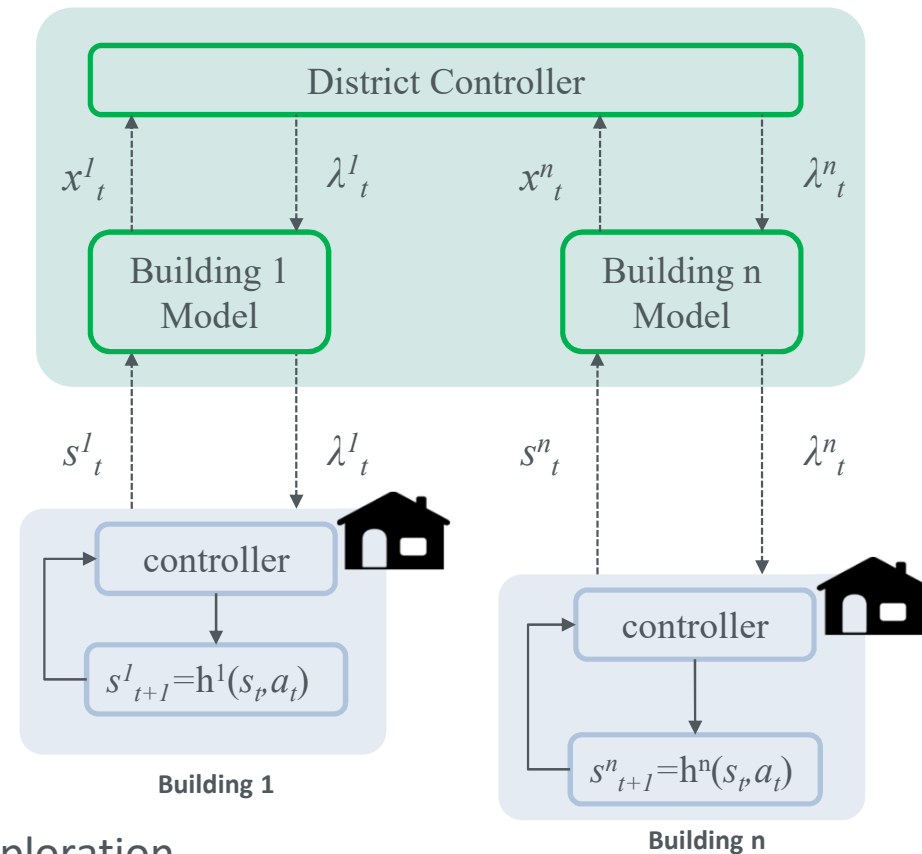

**Perspectives:** District scale : control of a cluster of buildings without explicit knowledge of local control.

# Mixing data and knowledge for modeling and control of building energy systems

**Benoit DELINCHANT**

*Grenoble Electrical Engineering Lab  
Grenoble-INP*



DESCARTES  
**Decision-making in  
Critical Urban Systems**

**SINERGIE**

**French-Singaporean research network programme on Renewable Energy**

**Monday, 6 November 2023**

**Session-03 - Smart Buildings and Smart Cities**

**NTU Reality Theatre - Research Techno Plaza (RTP)**

**Singapore**

