



HAL
open science

Introduction of degradation modeling in qualification of the novel subsea technology

Himanshu Srivastav, Mary Ann Lundteigen, Anne Barros

► To cite this version:

Himanshu Srivastav, Mary Ann Lundteigen, Anne Barros. Introduction of degradation modeling in qualification of the novel subsea technology. Reliability Engineering and System Safety, 2021, 216, 10.1016/j.ress.2021.107956 . hal-04317601

HAL Id: hal-04317601

<https://hal.science/hal-04317601v1>

Submitted on 22 Jul 2024

HAL is a multi-disciplinary open access archive for the deposit and dissemination of scientific research documents, whether they are published or not. The documents may come from teaching and research institutions in France or abroad, or from public or private research centers.

L'archive ouverte pluridisciplinaire **HAL**, est destinée au dépôt et à la diffusion de documents scientifiques de niveau recherche, publiés ou non, émanant des établissements d'enseignement et de recherche français ou étrangers, des laboratoires publics ou privés.



Distributed under a Creative Commons Attribution - NonCommercial 4.0 International License

Introduction of degradation modeling in qualification of the novel subsea technology

Himanshu Srivastav^a, Mary Ann Lundteigen^a, Anne Barros^{b,*}

^a*Norwegian University of Science and Technology, Trondheim, Norway*

^b*CentraleSupélec, Paris, France*

Abstract

All-electric systems are the novel subsea technology that is an upgrade of widely deployed electro-hydraulic control systems. They promised more reliable equipment and a safer environment. An all-electric production system performs several functions related to hydrocarbon production control. It also performs safety functions by isolating the reservoir from the environment. Safety functions are performed by activation of safety valves. These safety valves include electric springs in their design instead of mechanical springs. Failure modes and effects analysis of these valves show that interruptions in the power supply appear as random demands to the safety valves, and experiencing such demands may deteriorate their performance. However, the current reliability assessment of safety valves does not consider any degradation phenomena. This paper's main objective is to investigate the degradation modes caused by demands and their influence on the all-electric actuation system's performance under different maintenance strategies. A degradation modeling framework based on the multiphase Markov process is proposed. The impact of demand is modeled by changing the initial condition or by increasing the transition rates between two degraded states. The amplitude of the increment depends on the condition at the time of the demand. Analytical formulae are developed for the time-dependent reliability assessment.

*Corresponding author

Email address: anne.barros@centralesupelec.fr (Anne Barros)

Keywords: Technology qualification, All-electric subsea production system, Degradation due to demands, Safety performance assessment, Harmful testing, Multiphase Markov process

1. Introduction

1.1. Novel Subsea Technology

All-electric systems are considered as the update of widely used electro-hydraulic systems in the domain of Oil & Gas industry. Theobald et al. [1] discussed the benefits of all-electric subsea production and control systems. In their work, the authors advocate all-electric technology as it overcomes the typical weaknesses of electro-hydraulic technology. Some of them are the system's susceptibility to hydraulic fluid cleanliness, materials compatibility, hydro-static effects in deeper waters, and limitations over long-distance tie-backs. The author also explains the economic benefits of all-electric technology. Since all-electric systems are lighter when compared to conventional electro-hydraulic systems, they require less space. This enables lesser capital expenditure during the initial phase of the project. The higher reliability and safety benefits of all-electric systems ensured saving in operational expenditures during operations.

1.1.1. Industrial initiative in the novel subsea technology

This novel subsea technology's promising nature also attracted various industry players to take the initiative in these directions. Some of the key examples are as follows. Abicht et al. [2] presented the status of the initiative taken by Equinor in all-electric subsea technology. The authors discussed the fundamental features of the novel technology, operational potential, steps required to close the technical gaps, and the maturity of the new technology. More recently, MacKenzie et al. [3] presented a summary of the joint initiative from Equinor and Total, namely "all-electric subsea". The authors explain that an all-electric approach is beneficial regarding cost, project execution, operational flexibility, and standardization. It is believed to be a game-changing technology in the domain of Oil & Gas industry. Winther-Larssen et al. [4] presented a case study on

all-electric subsea production systems. This case study was performed by Aker Solution. In this case study, the authors optimized the subsea control module's field architecture to show that it is possible to reduce the control system's cost
30 in the subsea production system.

1.1.2. Challenges with the novel subsea technology

However, being a novel subsea technology, there are some challenges with it. Wilson et al. [5] pointed out the disadvantage due the design of electric actuators. It is not possible to install analog indicators about the valve position or a
35 mechanical valve lock-open override in electric actuators. In the absence of these features, it is challenging to have remotely-operated-vehicles surveys and well operations. Det Norske Veritas (DNV)[6] has discussed that the development in all-electric technology is challenging the existing safety philosophies. They have argued that the degree of independence of safety functions using all-electric con-
40 cepts is still unknown. The existing industry standards and guidelines may not sufficient to develop confidence about the safety capabilities of novel all-electric technology

1.2. Technology Qualification Process (TQP)

In a subsea environment, new technology has to hold very high standards
45 regarding reliability and safety. At the same time, it is also mandatory for the new technology to be profitable in terms of return on investments (ROIs). These factors must be managed prior to implementation and are achieved through technology qualification. Technology qualification aims at providing sufficient evidence that the new technology is fit for the purpose without high risk.

1.2.1. Relevant frameworks for TQP

Technology qualification programs are implemented using standard procedures. One of the most relevant frameworks for a subsea environment are DNV-RP-A203 [7] for recommended practices for technology qualification. [DNV-RP-A203](#) helps technology providers to develop confidence in the novel technology

55 by following a systematic risk-based qualification process. This process includes
the following stages [8]:

1. Qualification basis: Technological needs are framed and described thoroughly in this stage. This stage answers typical questions like what is this technology and application to be qualified? How to measure it?
- 60 2. Technology assessment: In this stage, an assessment is performed about the novelty of the technology.
3. Threat Assessment: In this stage, various failure modes are identified, and associated risks are assessed.
4. Qualification plan: This stage provides the necessary qualification method
65 to reduce the assessed risks for each failure mode.
5. Execution of plan: The qualification plan is implemented in this stage, and results and data are gathered as qualification evidence.
6. Performance assessment: In this last stage, the collected qualification evidence is assessed against the qualification basis. If the results are not
70 satisfactory, modifications are proposed in the previous stages.

In other widely accepted recommended practices includes API RP 17N [9] for subsea production system reliability, technical risk, and integrity management, and API RP 17Q [10] for recommended practices on subsea equipment qualification.

75 1.2.2. *TQP for safety system with novel technology*

A safety system with new subsea technology has responsibilities to perform safety functions in certain situations or whenever required (such as plant shutdown, emergency, etc.) in order to prevent an uncontrolled hydrocarbon fluid release and subsequent situation of the blowout. These situations are termed as
80 “demand situation”, meaning that the safety system is considered on standby by default. A safety system has to follow several requirements to be a qualified technology with respect to industrial norms. These requirements are prescribed in IEC 61508[11] and IEC 61511[12]. These standards also provide procedures

to assess such systems' safety capacities, but only a few studies are available
85 in the public domain that implements them. Halvorsen et al. [13] presented
a safety assessment of an all-electric subsea tree system developed by Statoil
Hydro-FMC Technologies. This study shows that in line with IEC 61508, the
actuator system follows the required industrial safety limits.

1.3. Requirement for Update in Technology Qualification

90 As they are standby systems, failure of safety components may remain hid-
den in a subsea environment. Therefore, periodic tests are performed to ensure
the system can act on demand. These periodic tests are called "proof tests".
While assessing the safety system's safety capabilities, the requirements pre-
scribed in the IEC 61508 assume that: (i) the system is perfectly restored to
95 a new state after every proof test and (ii) there is no degradation in its safety
capability due to demands and proof tests. However, for the safety system with
mechanical components (such as valves and pumps), these assumptions are ques-
tionable [14, 15]. If the procedure mentioned in IEC 61508 is followed without
any modification, the safety capabilities of novel subsea technology systems will
100 likely be overestimated. It can lead to wrong decisions in the qualification, i.e.,
that the system is sufficiently safe, while in reality, the system will lose its abil-
ity after a while, perhaps unnoticed. Consequently, the concepts of degradation
modeling need to be incorporated while assessing the all-electric system's safety
performance to overcome such a situation.

105

1.4. Research Problem in Focus

In this paper, we present the case study of the safety valves of an all-electric
actuation system. In case of an emergency or planned plant shutdown, these
safety valves perform the safety function by isolating the reservoir. In addi-
110 tion to these situations, all-electric actuation systems may experience random
power supply interruptions. In the absence of a power supply, the safety valve
closes itself due to a fail-safe arrangement. The valve comes back in an open

position for normal operation on the restoration of the power supply. These power supply interruptions appear as a demand situation to the safety valves. In this paper, we study the effect of power supply interruptions on the safety valve's performance. Hereafter the term "demands" is meant these power supply interruptions. Many times activation due to demand may deteriorate the mechanical part of the safety valves. This deterioration may cause degradation in the performance and may even lead to the system's eventual failure. (This degradation phenomenon is discussed in detail in section 2). In this case, the procedure to assess the safety performance mentioned in the IEC 61508 needs to be updated.

This paper aims to address this phenomenon of degradation due to demands and introduce degradation modeling techniques to assess these systems' realistic performance. As reviewed hereafter, this is a relatively common phenomenon across the industries, and it is an arising concern for the design of new all-electric subsea production fields.

The internal aging process of the mechanical components may get interfered with by experiencing the demand situations. According to the existing literature [16, 17, 18], the demands can be modeled as a shock to the internal degradation process. In this paper, it is considered that the experience of a shock may generate two types of exclusive effects: (i) the random shock causes deterioration to the limit that the safety valves could not perform its safety function. This type of effect is categorized as "immediate degradation" and corresponds to a failure. (ii) the random shock increases the transition rate towards the failed state. This type of effect is categorized as "residual degradation".

All the existing models are based on a binary representation of the performance of the safety valves, meaning that they can be either functioning or failed.

In this paper, we improve the existing modeling framework by introducing

degradation modeling techniques. We added intermediate degraded states between perfectly working and failed states. We intend to model the impact of the demand situation on both the degradation level and the degradation rate. The increment of the transition rate between two degraded states after a demand is a function of both the current system state and the number of previous demands experienced by the safety valves. We provide analytical solutions in order to assess:

- the time-dependent unavailability of a safety valve when it has experienced a given number of demands with a given maintenance strategy
- the average unavailability of a safety valve over a mission time. From the available knowledge about the system, it is known that the safety valve will experience a given number of demands in the mission time.

Sometimes, proof tests may also damage the safety valve’s performance by adding mild stress on the mechanical component of safety valves. The developed framework also considers these harmful impact periodic tests while assessing the performance of these valves. This paper’s remaining is organized as follows: Section 2 presents a relevant use case from the domain of Oil & Gas industry and associated background. Section 3 discusses the state-of-the-art literature review on this topic. Section 4 presents the modeling assumptions and formulates an analytical modeling framework. Section 5 discusses numerical results, and Section 6 concludes the paper.

2. Use Case

2.1. System Description

In subsea fields, a production tree consists of gate-valves and choke-valves. It mainly controls hydrocarbon production, monitors the well condition, and injects chemicals when required. It also performs the safety function of “isolating the reservoir” from the environment in case of a shutdown or emergency [19]. An all-electric actuation system controls the movement of safety valves. [These](#)

safety valves stay in an open position for the normal mode of operation but need to be closed to perform the safety function. Figure 1 shows the general architecture of an all-electric actuation system. All-electric actuation systems use electric springs to activate the safety valves. An electric spring functions on the following principle: a compressed spring controls the valve's movement, and the spring stays compressed whenever the valve is in the open position. Once the power to the clutch is cut or switched off, the spring decompresses and pushes the valve to the dedicated fail-safe position [20]. Electric power is needed to compress the electric spring to actuate valves to be in the open position. This power is either supplied through topside and/or a dedicated subsea Battery management system (BMS). In the architecture shown in Figure 1, BMS acts as an uninterruptible power supply in case the power link from the topside is interrupted. A dedicated safety controller observes the system status and commands the valve actuators to their fail-safe positions. The dedicated switch module controls the electrical power distribution to the actuators. With these switches, each actuator can be connected (or disconnected) separately. Each actuator contains two motors, each with a dedicated electronic drive.

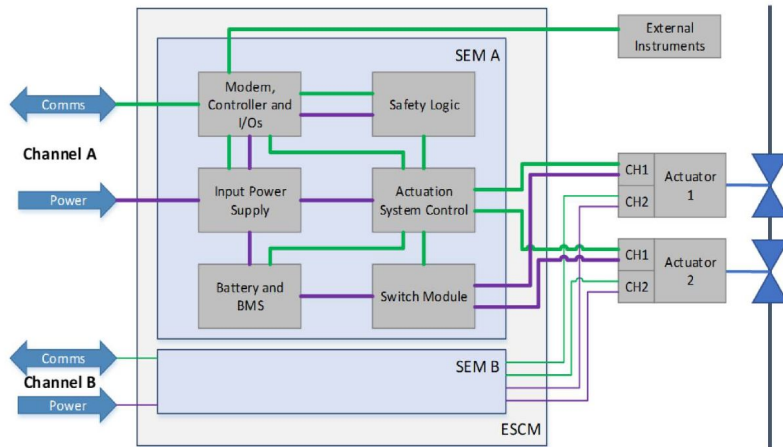

Figure 1: All-Electric System Architecture [21]

2.2. Degradation phenomena

190 A failure modes and effects analysis (FMEA) of this system shows that one of the critical high-risk of failures may occur in the situation when the safety valves are restored to an open position from a close position. The reason for such failures is that sometimes the torque provided by the actuator to open the valves is above the damage torque of the valve. As a consequence of this, the valve
195 can experience degradation in performance (i.e., leakage from the valve)[22]. The actuators will be activated whenever the power supply interrupts from the topside, and BMS will provide power. This can be defined as a demand situation on which the valve needs to perform a safety function. Such activation may induce degradation in the performance of the safety valves. The second
200 important risk of failure is due to the aging of and is gradual.

2.3. Background from Oil & Gas Industry

This case study is in the domain of the Oil & Gas industry, and the primary purpose of safety valves in the all-electric system is to ensure the safety of the facility. In Oil & Gas industry, the safety valves are generally an integral part
205 of a safety-instrumented system (SIS). In this subsection, we present relevant background from the domain.

2.3.1. Demand modes classification

Misumi and Sato [23] defined demand state of SIS as “State of the equipment under consideration (EUC) when the safety-related system is being required to
210 implement a particular safety function(s)”. Based on the frequency of demands standards of the domain (IEC 61508 [11]) classifies the modes of operation for a SIS in the Table 1.

IEC 61511 [12] is a standard for process sectors and it is based on IEC 61508. It classifies modes of operation as per Table 2.

2.3.2. Reliability measure

215 The measure to assess the reliability is different in different modes of operation. In the low-demand mode of operation, reliability of the safety-instrumented

Table 1: Mode of operation as per IEC 61508

Mode	Details
Low demand mode	Safety Functions demand rate is less than 1 per year
High demand mode	Safety Functions demand rate is more than 1 per year
Continuous mode	Safety Functions demand rate is more than 1 per year and Safety function operates as continuous control function

Table 2: Mode of operation as per IEC 61511

Mode	Details	Remarks
Demand mode	Safety Functions activated in response of process condition	Equivalent to Low-demand mode of IEC 61508
Continuous mode	A hazardous event will occur as soon as the safety instrumented function(SIF) experiences the dangerous failure	Equivalent to High-demand and Continuous mode of operation of IEC 61508

system (SIS) is assessed by the probability of failure on demand (PFD_{avg}), whereas in the High demand mode of operation, the reliability measure of SIS is defined by the average frequency of dangerous failures (is denoted by PFH). It is important to mention that although PFD_{avg} and PFH are associated with the assessment of the reliability of SIS, they are not comparable. This can also be understood by a dimensional analysis of these measures, PFD_{avg} is dimensionless quantity, whereas PFH has the dimension of frequency (time^{-1}).

225

2.3.3. Degradation modeling

In the Nuclear industry, a similar problem is addressed to some extent in [24, 25]. Solutions in terms of analytical formulation for relevant reliability measures

are developed. The basic idea is to quantify the degradation due to periodic
230 inspection tests and random demands and to consider that the degradation
caused by both are of the same magnitude. Then, the failure rate at time t
depends on the total number of tests & demands experienced by the component
until time t . However, the degraded states are not explicitly modeled, and the
safety valves are either in a functioning state or in a failed state.

235 In the domain of the oil & gas industry, there is less literature available on
this topic. Zhang et al. [26] studied the testing and maintenance strategies for
safety valves with a redundant structure. This work is based on the follow-
ing central assumption: (i) each safety valve has three performance levels (i.e.,
working, degraded, and failed), (ii) perfection detection of degraded states dur-
240 ing proof tests is not always possible. In their work, the authors have estimated
the life cycle cost of various testing and maintenance strategies and performed
a sensitivity analysis of the results with the degree of detection of degraded
states during proof tests. Zhang et al. [27] analyzed the performance of the
safety valves when a Gamma process is utilized to model the degradation pro-
245 cess. In this work, the maintenance decision is based on the indicator about the
degradation of the safety valve. There were three values (i.e., good, degraded,
failed). The authors discussed preventive and corrective maintenance strategies
and associated life cycle costs based on the available information at the time
maintenance.

250 Although the authors have improved upon the standard binary state model
of the safety valves, the factors like experience of demands, or impact of harmful
tests on degradation process is not covered in these works.

Colombo et al. [28] proposed regression-based machine learning techniques
for estimating the reliability of the safety valves. In their work, the authors
255 utilized a data set collected from a Brazilian oil and gas company. It has been
claimed that for this data set, the machine learning techniques outperformed the
traditional statistical models (such as Weibull distribution). This work utilized
the black-box approach for reliability estimation. The developed method is fed
with data, and it gave output in terms of reliability prediction. Although the

260 proposed method is efficient, it does not provide any insight into the safety valves' failure mechanism or degradation behavior.

3. State-of-Art

3.1. DTS models

There are few literature available in Oil & Gas industry on quantifying the degradation in performance of safety valves due to experiencing the real demand situation. However, there exists material in abundance about the models used for similar situations in other application areas, namely degradation-threshold-shock (DTS) models. These models generally represent two competing failure modes: an internal continuous degradation process and an external one with shocks (representing a random environment, a demand, an external accident). Both modes can lead to the eventual failure of the system. DTS models are extensively utilized to model interferences of these two competing causes. In our case, the internal degradation is the natural aging of the safety valves, and the shocks are real-demand situations that can interfere with the internal degradation process. Lemoine and Wenocur [29] were probably the first ones to develop DTS models. The occurrence of shocks leads to immediate failure of the system. Singpurwalla [30] presented a comprehensive review of different classes of contemporary reliability models, including DTS models. Since there has been ample research on DTS models with applicability in different domains, some are mentioned hereafter.

3.2. DTS with dependent failure modes

Initially, DTS models were utilized with the assumption that shocks and degradation are independent competing causes of failure [31, 32]. Soon, it is realized that this assumption of an independent cause of failures needs to be modified to capture real-time failure phenomena.

Lehmann [33] provides a rich conceptual framework to study degradation failure models. The author computed (analytically) survival function for DTS

models where internal degradation (modeled as Lévy process) interferes with
the random environment (modeled as co-variate, assuming that intensity of the
process also depends on the current process degradation level). The author
290 extended this analysis to repairable items.

Wang et al. [34] studied DTS models with the perspective that a random
shock interferes with the internal degradation process. In this study, the au-
thors considered the following types of shocks based on the shock magnitude:
295 (a) shocks with moderate impact and (b) shocks with the fatal impact. The
Occurrence of fatal shock immediately led to the system's failure, whereas mod-
erate shocks interfere with the natural degradation process. The authors mod-
eled the interference of these shocks on the degradation process for these two
effects exclusively: (i) every time component experienced a shock, the failure
300 rate increases by a factor (> 1) (ii) due to shocks, the degradation (continuous
process) increases with a random step. The authors developed analytical for-
mulae to analyze the reliability of the system considering the scenarios in which
the occurrences of the shocks either periodic or follows a homogeneous Poisson
process

305 Huynh et al. [35, 36] utilized DST models to propose age-based maintenance
strategies and developed associated analytical cost models. The authors consid-
ered the component degradation to follow a homogeneous gamma process and
the shock arrival time to follow a non-homogeneous Poisson process (NHPP).
The intensity of the shock arrival process is modeled by switching it between
310 two non-decreasing time-dependent functions. The switching of the intensity
occurs as soon as the component degradation reaches a predefined threshold.

In [37, 38, 39], the authors included the effect of random shocks in the anal-
ysis of pitting corrosion with multiple internal degradation processes. Actually,
there exist physical phenomena that can deteriorate with several degradation
315 "paths". In pitting corrosion, many small pits appear on the surface of the
metal, and crack formation in each pit follows a path that has to be modeled
by a dedicated stochastic process [40]. Hence, to model such a situation, mul-
tiple degradation processes need to be considered. Castro et al. [41] utilized

a homogeneous gamma process to model multiple degradation processes. The
320 number of degradation process is assumed to follow a homogeneous Poisson
process where the initiation time of each path is randomly distributed.

3.3. DTS models for multi-state systems

One main assumption in the above-mentioned works is that the system states
are either binary states (i.e., unique functioning state & unique failed state) or
325 continuous ones. Then, the authors improved lifetime models or degradation
models on a case-to-case basis to capture the physical phenomena under con-
sideration.

In the framework of the SUBPRO (which is a Centre for Research-based
Innovation), discussions with industry partners suggested that it is reasonable
330 to assume that a safety valve can be in a functioning state but with some few
stages in degraded performance. This situation leads to the domain of multi-
state systems (MSS). In principle, MSS can be utilized as a discretization of
an underlying continuous degradation process. Li and Pham [42] presented a
methodology to divide a continuous degradation process (for a general proba-
335 bility distribution) into a discrete finite state space.

First, Teresa Lam and Yeh [43], Ohnishi et al. [44] studied the time-dependent
reliability of MSS assuming exponential sojourn time in degraded states and
developed an analytical solution to find optimal replacement condition-based
340 policy. Pham et al. [45, 46] developed analytical formulae to calculate var-
ious reliability measures such as mean operation lifetime, mean time to the
first failure for the multi-state degraded system subjected to partial repairs and
catastrophic failures.

345 Later on, Lisnianski and Levitin [47] discussed MSS with variable demand
(shock) situations in the book Multi-state system reliability: assessment, op-
timization, and its application. Segovia and Labeau [48] utilized phase-type
distributions to develop reliability models of MSS subjects to random shocks.

The authors first developed analytical formulae considering that the cumulative
350 damage caused by one shock can exceed several degradation thresholds. This
allows the system to have a transition to more than one degraded state. Then,
later on, the authors developed a formulation where the arrival of the next shock
can cause damage in such a way that the system is only allowed to go to an
immediate higher level of the degraded state.

355

More recently, Eryilmaz [49] developed analytical formulae for reliability
measures like mean residual time, survival function for a multi-state system
with random numbers of states. The author assumed two critical thresholds
on the magnitude of each random shock. If the magnitude of a random shock
360 causes cumulative damage to cross the higher critical threshold, the system is
assumed to be failed. If the magnitude of a random shock is less than the lower
critical threshold, then no damage is done by that shock, and the state of the
system remains the same. If the magnitude of the random shock lies between
two critical thresholds, the system is assumed to be moved to the state with
365 partial damage. This way of modeling leads to a random number of states until
the system fails. The author used a phase-type distribution to model the shock
arrival times. Lin et al. [50] extended the MSS models for continuous-time semi-
Markov models and performed reliability assessment of the system in the pre-
sence of random shocks. The authors considered mainly two exclusive effects of
370 a random shock on the system (i) a shock either directly can cause the failure of
the system termed as extreme shock or (ii) a shock can increase the transition
rate of one degraded state to another one by a constant factor (this type of
shock is termed as cumulative shock).

375 However, we did not find in the existing literature or any work in which the
increment of the transition rate between two degraded states after a shock is a
function of both the current system state and the number of previous shocks.
Such an assumption can be realistic in practice and requires defining a more
generic modeling framework than the existing ones. In this paper, we propose

380 to use a multi-phase Markov process to address this problem.

4. Modeling framework

This section first presents the relevant assumptions for modeling the demands situation and degradation caused by the demands. Formulae for performance analysis of safety valve between two consecutive demands are then
385 illustrated, considering that the demand times are known. Subsequently, the formulae to model the impact of demands in the presence of different maintenance strategies are presented, and finally, formulae for performance analysis of safety valve are developed.

390 4.1. Modeling Assumptions

- The system under consideration has four possible levels of performance, i.e., **Good**, **Ok**, **Poor**, **Fail**. These levels are represented by four states (symbolized by A, B, C, D) of the Markov process. The same basic model was adopted for performance analysis of safety valve subjected to degradation due to proof tests [51, 52]. It is pertinent to mention here that the
395 framework developed in this paper is a generic extension of the framework developed at [51, 52]. The framework developed at [51, 52] had a major limitation that it was not able to assess the impact of random demands on the performance degradation of safety valves. We present an extension
400 of the existing framework to overcome this particular weakness.
- Dangerous Undetected (DU) failures are mainly responsible for the unavailability of safety valves, which are passive by nature. These failures can only be detected by periodic proof tests [11]. There are two kinds of DU failures considered here in this model: (i) λ_a is responsible for progressive degradation of performance of safety valve. It can also be called
405 transition rate responsible for aging (ii) λ_u is responsible for immediate

failure of safety valve. Figure 2 shows the state transition diagram of this system.

- The transition rate responsible for aging (λ_a) can be changed due to the experience of the actual demand situation and experiencing the proof tests.
- The framework has been developed assuming that proof tests only reveal the failed state. True degradation remains hidden even during proof tests.
- Duration of proof tests, repair activity duration is considered negligible compared to the lifetime of the equipment.

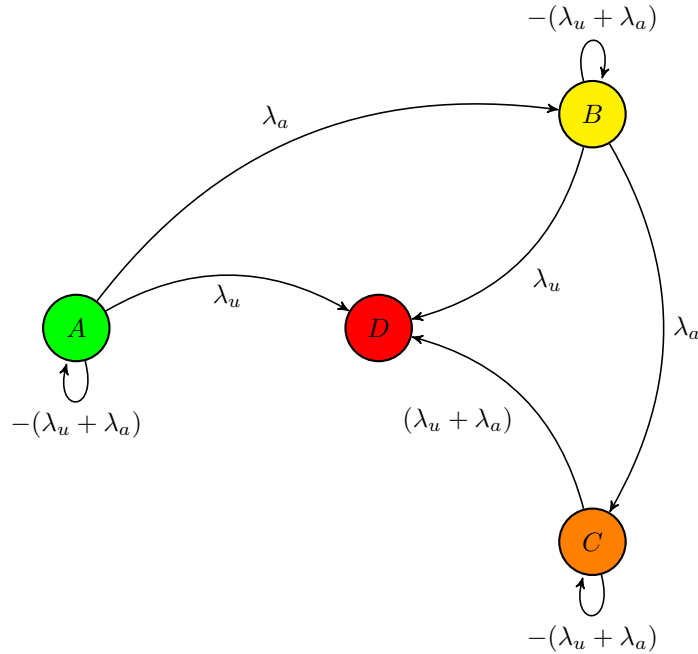

Figure 2: Representation of degradation process of safety valve as Markov process

We define a stochastic process $\{X_t; t > 0\}$ to model the system states at time t . $\mu_t = \{\Pr[X_t = A], \Pr[X_t = B], \Pr[X_t = C], \Pr[X_t = D]\}$ is the collection of probabilities in each state at time t in the form of a row vector. $\mathcal{B}[\lambda_a]$ defines the transition rate matrix for this process. If $\mathcal{B}[\lambda_a]$ is constant over a phase,

then Chapman-Kolmogorov's equation [53, 54] is given by following:

$$\frac{d\mu_t}{dt} = \mathcal{B}[\lambda_a]t \quad (1)$$

$$\mu_t = \mu_0 \exp(t\mathcal{B}[\lambda_a]) \quad (2)$$

420 where μ_0 = stands for the initial probability vector for the system, and $\mathcal{B}[\lambda_a]$ is defined by the matrix 3.

$$\text{Transition rate matrix}(\mathcal{B}[\lambda_a]) = \begin{bmatrix} -(\lambda_a + \lambda_u) & \lambda_a & 0 & \lambda_u \\ 0 & -(\lambda_a + \lambda_u) & \lambda_a & \lambda_u \\ 0 & 0 & -(\lambda_a + \lambda_u) & \lambda_u \\ 0 & 0 & 0 & (\lambda_a + \lambda_u) \end{bmatrix} \quad (3)$$

In this case the instantaneous unavailability ($U(t)$) is given by:

$$U(t) = \Pr[X_t = D] = \mu_0 \exp(t\mathcal{B}[\lambda_a]) \begin{bmatrix} 0 \\ 0 \\ 0 \\ 1 \end{bmatrix} \quad (4)$$

4.2. Modeling of Demand Situation

In this paper, the arrival of demands is modeled with a homogeneous Poisson
425 process (HPP) with the arrival rate (λ_d). Demands are s-independent (stochastically independent) on the system dynamics. It means that the arrival of demands is independent of the current state of degradation. This is a standard practice of the field to model demand situation.[11, 55, 56, 57]. The demand duration is negligible compared to the mission time of the SIS.

430 4.3. Modeling of Impact of Demands

Experiencing a demand situation may affect the safety valve's degradation process in one of the two following ways:

1. First, the deterioration caused by demands is to the extent that it can immediately change the degradation level of the safety valve. For example:
435 if a safety valve is in state A at the time of demand, then due to demand,

the state of safety valve may change to one of the states B, C, D ; similarly from state B transitions to states C, D and from state C to state D . To model this effect, we define:

T_n : time of n^{th} demand

440 $\mu(T_n^+)$: state probabilities vector just after the demand

$\mu(T_n^-)$: state probabilities vector just just before the demand

α_{ij} : probability of instantaneous jump to state i from state j ;

$$\alpha_{ij} = \Pr[X(T_n^+) = i \mid X(T_n^-) = j], \quad (5)$$

$$\forall i \geq j; i, j \in \{A, B, C, D\}$$

Then, due to experience of demand situation the immediate changes in state probabilities is given by equation 6

$$\boldsymbol{\mu}(T_n^+) = \boldsymbol{\mu}(T_n^-) \cdot \begin{bmatrix} \alpha_{AA} & \alpha_{BA} & \alpha_{CA} & \alpha_{DA} \\ 0 & \alpha_{BB} & \alpha_{CB} & \alpha_{DB} \\ 0 & 0 & \alpha_{CC} & \alpha_{CD} \\ 0 & 0 & 0 & 1 \end{bmatrix} \quad (6)$$

445 It is important to note that $\alpha_{ij} = 0, \forall i < j$. As the system can either degrade or stay in the same state, it can not improve the state by experiencing the demand. By tuning the parameters of the above matrix, one can set the degree of strength or fragility of the safety valve. For example: if we tune α_{AA} much higher than $\alpha_{BA}, \alpha_{CA}, \alpha_{DA}$, then the situation is less prone to the jump due to experience of demand. Such a system can be less sensitive to the arrival of demand situation. Similarly, if we tune α_{AA} much lower than $\alpha_{BA}, \alpha_{CA}, \alpha_{DA}$, then the system is more likely to degrade on experiencing a demand. Such systems can be categorized as fragile systems.

455 2. Second, the deterioration caused by the demand can be weak and may not alter the system's current degradation level. It will leave residual stress in the safety valve, which will increase the transition rate responsible for aging. The increment in the transition rate responsible for aging is

proportional to both the number of demands experienced by the safety
460 valve and the level of degradation at the time of demand occurred. For
example: if the transition rate of aging is given by λ just before the arrival
of demand, and if the system is in state A just before and just after the
demand time, then the transition rate of aging is increased by the factor
of ω_A . Similarly, for state B and state C , this factor is given by ω_B, ω_C
465 respectively. It is important to note that $1 < \omega_A < \omega_B < \omega_C$. If the
system is in a higher degraded state, it will age faster. The modeling of
this effect is reflected in Equation 7.

If the system is found in a failed state at the time of periodic proof tests, a
repair is performed based on the chosen maintenance strategy. Since the proof
470 tests do not reveal the true degradation level of the system, the framework
is developed for corrective maintenance only. It is important to note that the
maintenance tasks are only performed at the time of periodic tests. In the subsea
environment, the failures are not self announcing and can be detected only
through periodic proof tests. There are two maintenance strategies considered in
475 this paper.

- AGAN (As-good-as-new): In this maintenance strategy, every time the
system experiences a failure due to a demand situation, it is replaced with
a new one. This is an expensive strategy.
- ABAO (As-bad-as-old): In this maintenance strategy, every time the sys-
480 tem experiences a failure due to a demand situation, the minimal repair
is performed to make it functioning again. This is the most economic
strategy.

Figure 3 shows the possible evolution states and transition rates for aging
after experiencing the demands situation. The system starts in the initial con-
485 dition State A , with the initial transition rate for aging λ . We assume that first
demand occur after n proof tests. Just before the demand situation, there are
four possible states. Due to the experience of demand, the system can have one

of the unique six combinations as shown in Figure 3.

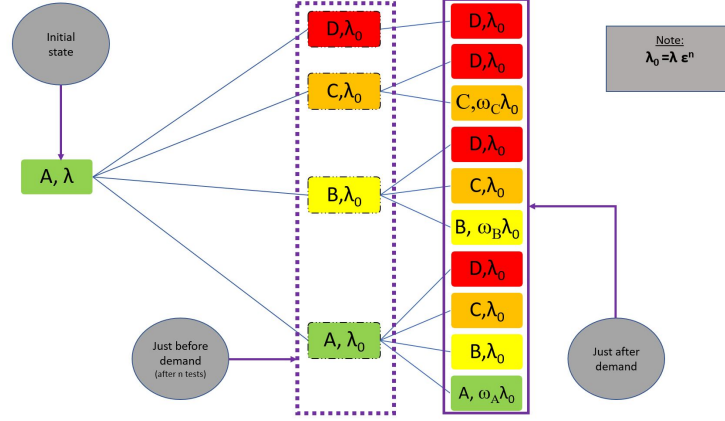

Figure 3: Possible combinations of states and transitions rate by experiencing the demand situation

The dependence of the transition rate for aging on the degradation level of the system makes the transition rate for aging a discrete stochastic variable. We define:

$\Lambda_n^+ := \Lambda(t = T_n^+)$: transition rate for aging just after the n^{th} demand.

$X_{T_n^+}$: the state of the system just after the n^{th} demand.

$X_{T_n^-}$: the state of the system just before the n^{th} demand.

$\omega_A, \omega_B, \omega_C$ are state dependent impact of demand situation on transitions rates.

Initial condition: $\Lambda_0 = \lambda_0, X_{t=0} = A$

$$\Lambda_n^+ := \Lambda(t = T_n^+) = \begin{cases} \omega_A \Lambda_n^-, & \text{if...}(X_{T_n^+} = A | X_{T_n^-} = A) \\ \omega_B \Lambda_n^-, & \text{if...}(X_{T_n^+} = B | X_{T_n^-} = B) \\ \omega_C \Lambda_n^-, & \text{if...}(X_{T_n^+} = C | X_{T_n^-} = C) \\ \Lambda_n^-, & \text{else... in all other cases} \end{cases} \quad (7)$$

Here indicator function $\mathbb{1}$ is defined by equation 8.

$$\mathbb{1}_{\text{text}} = \begin{cases} 1 & \text{if "text" is true} \\ 0 & \text{otherwise} \end{cases} \quad (8)$$

4.4. Impact of Periodic Tests

500 With a subsea safety valve, periodic proof tests are required to assess the safety valve availability. However, these periodic tests can generate additional stress on the safety valve. To incorporate this effect, the existing literature chooses to increase the transition rate pertaining to aging by a constant factor [58, 52]. In this paper, a similar approach is adopted. We define: $\epsilon; \epsilon > 1$ impact of
505 harmful tests on the system. Then, for $t > T_n^+$, Harmful impact is modeled by Equation 9:

$$\Lambda(t) = \epsilon^{(n_t)} \Lambda_n^+ \quad (9)$$

where

$$n_t = \left\lceil \frac{t}{\tau} \right\rceil - k_n$$

n_t : number of periodic tests experienced (at time t) after the n^{th} demand.

510 k_n : number of periodic tests experienced before the n^{th} demand

4.5. System dynamics evolution between two consecutive demands

Before presenting the performance analysis for a mission time, the evolution of the system dynamics (i.e., probabilities in each state) for a typical situation is formulated in this sub-section. Figure 4 shows a typical demand situation for a
515 safety valve operating in the subsea environment. In this scenario, consecutive demands occurred at time T_1, T_2 . There are some periodic tests performed between these two demands. For this situation, time-dependent evolution of probabilities is given by Equation 10:

For $T_1 < t < T_2$, and given that $\Lambda_{t=T_1^+} = \lambda$

$$\boldsymbol{\mu}(t) = \boldsymbol{\mu}(T_1^+) \mathcal{F}(t, T_1, \tau, k_1, M, \lambda, \epsilon) \quad (10)$$

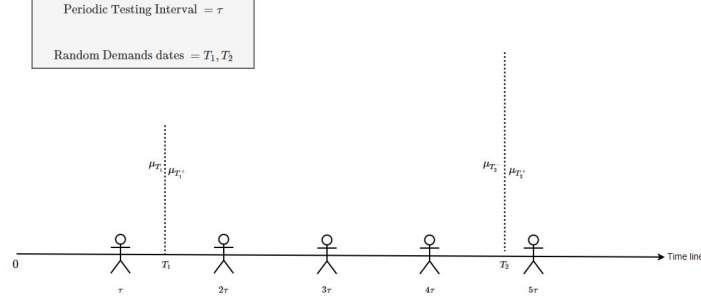

Figure 4: A typical example of two consecutive demands

520 Where \mathcal{F} is a function discussed in 4.5.1. Based on this typical example, the general solution for the evolution of system dynamics between n^{th} and $(n+1)^{\text{th}}$ is given by the following equation 11.

For $T_n < t$, and given that $\Lambda_{t=T_n^+} = \lambda; T_n$

$$\boldsymbol{\mu}(t) = \boldsymbol{\mu}(T_n^+) \mathcal{F}(t, T_n, \tau, k_n, M, \lambda, \epsilon) \quad (11)$$

525 The function \mathcal{F} takes as arguments the current time (t), the occurrence time of the previous demand (T_n), the time interval between two periodic tests (τ), the number of periodic tests experienced up to the previous demand (k_n), the maintenance matrix M , the transition rate for aging just after the previous demand λ , the impact of the proof tests (ϵ). This function (\mathcal{F}) then returns a (4×4) matrix transformation, which by multiplication with the initial probability vector ($\boldsymbol{\mu}(T_n^+)$) gives the current state probabilities. This function \mathcal{F} is important as it will be used recursively in the next subsection for performance analysis of the safety valve for mission time.

4.5.1. *System dynamics evolution between two consecutive demands (Continued ...)*

535 To explain the formulation for \mathcal{F} , we need to understand the formulation for two different phases of the figure 4. With the initial probabilities vector is given

by $\mu(T_1^+)$; and transition rate for aging given by $\Lambda_{t=T_1^+} = \lambda_1$. Let us assume that, we choose a t such that

- Phase 1: $T_1 < t < 2\tau$

$$\boldsymbol{\mu}(t) = \boldsymbol{\mu}(T_1^+) \exp((t - T_1)\mathcal{B}(\lambda_1)) \quad (12)$$

540

- Phase 2: $2\tau < t < T_2$

$$\begin{aligned} \boldsymbol{\mu}(t) &= \boldsymbol{\mu}(2\tau^+) \left(\prod_{k=1}^{k=(n_t-2)} \exp(\tau\mathcal{B}(\epsilon^k \lambda_1)) M \right) \exp((t - n_t\tau)\mathcal{B}(\epsilon^{(n_t-1)} \lambda_1)) \\ &= \boldsymbol{\mu}(2\tau) M \left(\prod_{k=1}^{k=(n_t-2)} \exp(\tau\mathcal{B}(\epsilon^k \lambda_1)) M \right) \exp((t - n_t\tau) \cdot \mathcal{B}(\epsilon^{(n_t-1)} \lambda_1)) \\ &= \boldsymbol{\mu}(T_1^+) \exp((2\tau - T_1)\mathcal{B}(\lambda_1)) M \left(\prod_{k=1}^{k=(n_t-2)} \exp(\tau\mathcal{B}(\epsilon^k \lambda_1)) M \right) \exp((t - n_t\tau)\mathcal{B}(\epsilon^{(n_t-1)} \lambda_1)) \end{aligned} \quad (13)$$

Based on the above equation 13, 12, we can express \mathcal{F} in following manner for the typical demand situation represented by Figure 4.

$$\begin{aligned} &\mathcal{F}(t, T_1, \tau, k_1, M, \lambda_1, \epsilon) \\ &= \begin{cases} \exp((t - T_1)\mathcal{B}(\lambda_1)), & \text{when } T_1 < t < 2\tau \\ \exp((2\tau - T_1)\mathcal{B}(\lambda_1)) M \left(\prod_{k=1}^{k=(n_t-2)} \exp(\tau\mathcal{B}(\epsilon^k \lambda_1)) M \right) \exp((t - n_t\tau)\mathcal{B}(\epsilon^{(n_t-1)} \lambda_1)), & \text{when } 2\tau < t < T_2 \end{cases} \end{aligned} \quad (14)$$

Here, M represent maintenance matrix, ϵ is impact of periodic test, n_t number of periodic tests experienced by the SIS upto time t . τ time interval between two consecutive periodic test; $\mu(T_1^+)$ state probabilities just after the first demand, k_1 number of periodic tests experienced by the SIS upto demand time T_1 , in this particular case $k_1 = 1$.

545 Based on this typical example, the general solution for evolution of system dynamics between n^{th} and $(n+1)^{\text{th}}$ is given by following equation 15.

550 For $T_n < t$, and given that $\Lambda_{t=T_n^+} = \lambda; T_n$

$$\begin{aligned} & \mathcal{F}(t, T_n, \tau, k_n, M, \lambda, \epsilon) \\ &= \begin{cases} \exp((t - T_n)\mathcal{B}(\lambda)), & \text{for } T_n < t < (k_n + 1)\tau \\ \exp(((k_n + 1)\tau - T_1)\mathcal{B}(\lambda))M \left(\prod_{k=1}^{k=(n_i - (k_n + 1))} \exp(\tau\mathcal{B}(e^k\lambda))M \right) \cdot \exp((t - n_i\tau)\mathcal{B}(e^{(n_i - k_n)}\lambda)), & \text{for } (k_n + 1)\tau < t < T_{n+1} \end{cases} \end{aligned} \quad (15)$$

It is worth to note that the analytical formulation of the function (\mathcal{F}) is generic in nature. In this problem, a four state Markov process is considered to model the performance of the system, hence the function (\mathcal{F}) returns a (4×4) matrix. In a generic case, where the performance of the system is model by n levels, the function returns $(n \times n)$ matrix. In such cases, the transition matrix ($\mathcal{B}(\lambda)$) and maintenance matrix (M) is also of dimension $(n \times n)$.
555

In this section, we have developed formulation assuming two consecutive demands. In case three or more demands steps mentioned above recursively utilized as mention in section Appendix A

4.6. Performance analysis of a safety valve considering the impact of frequent demands and harmful periodic tests

560

In this paper, the performance indicator for a safety valve is measured by its unavailability, both instantaneous ($U(t)$) and average (U_{avg}). It is worth noting that the system is defined by the combination of two dependent stochastic random variables, i.e., the state of the system X_t and the transition rate responsible for aging Λ at any point of time. Λ is a discrete stochastic variable that changes either due to the experience of harmful tests or due to the demand. However, it stays constant between any of these external events (tests and/or demands).
565

Analytical formulae are developed to estimate performance indicators. In this regard, the system random demand times are assumed to be $[T_1, T_2, T_3 \dots, T_n]$, where n represents the number of random demand experienced by the safety valve by the time t . We define the state variable S_n : state of the system at the time of n^{th} demand.
570

4.6.1. Instantaneous Unavailability $U(t|T_1, T_2, \dots, T_n)$

$$\begin{aligned}
& \text{For } t \in [T_n^+, T_{n+1}^-); T_n \in (k_n \tau, (k_n + 1)\tau) \\
& U(t|T_1, T_2, \dots, T_n) \\
& = \text{instantaneous unavailability at time } t \text{ after experiencing } n \text{ demands} \\
& = \Pr[X_t = D] \\
& = \sum_{\forall i} \sum_{s \in \{A, B, C, D\}} \Pr[X_t = D | S_n^+ = s; \Lambda_n^+ = \lambda_n^i] \Pr[S_n^+ = s; \Lambda_n^+ = \lambda_n^i] \\
& = \sum_{\forall i} \{ \Pr[X_t = D | S_n^+ = A; \Lambda_n^+ = \lambda_n^i] \Pr[S_n^+ = A; \Lambda_n^+ = \lambda_n^i] \\
& \quad + \Pr[X_t = D | S_n^+ = B; \Lambda_n^+ = \lambda_n^i] \Pr[S_n^+ = B; \Lambda_n^+ = \lambda_n^i] \\
& \quad + \Pr[X_t = D | S_n^+ = C; \Lambda_n^+ = \lambda_n^i] \Pr[S_n^+ = C; \Lambda_n^+ = \lambda_n^i] \\
& \quad + \Pr[X_t = D | S_n^+ = D; \Lambda_n^+ = \lambda_n^i] \Pr[S_n^+ = D; \Lambda_n^+ = \lambda_n^i] \} \\
& = \sum_{\forall i} \left[\{ [1, 0, 0, 0] \mathcal{F}(t, T_n, \tau, k_n, M, \lambda_n^i, \epsilon) \begin{bmatrix} 0 \\ 0 \\ 0 \\ 1 \end{bmatrix} \Pr[\Lambda_n^+ = \lambda_n^i; S_n^+ = A] \} \right. \\
& \quad + \left. \{ [0, 1, 0, 0] \mathcal{F}(t, T_n, \tau, k_n, M, \lambda_n^i, \epsilon) \begin{bmatrix} 0 \\ 0 \\ 0 \\ 1 \end{bmatrix} \Pr[\Lambda_n^+ = \lambda_n^i; S_n^+ = B] \} \right. \\
& \quad + \left. \{ [0, 0, 1, 0] \mathcal{F}(t, T_n, \tau, k_n, M, \lambda_n^i, \epsilon) \begin{bmatrix} 0 \\ 0 \\ 0 \\ 1 \end{bmatrix} \Pr[\Lambda_n^+ = \lambda_n^i; S_n^+ = C] \} \right. \\
& \quad + \left. \{ [0, 0, 0, 1] \mathcal{F}(t, T_n, \tau, k_n, M, \lambda_n^i, \epsilon) \begin{bmatrix} 0 \\ 0 \\ 0 \\ 1 \end{bmatrix} \Pr[\Lambda_n^+ = \lambda_n^i; S_n^+ = D] \} \right] \tag{16}
\end{aligned}$$

Here, i is number of possible values of transition rate (λ_n^i) after n demands. For example, as shown in figure 3, after first demand there are four possible values for transition rate: $\{\lambda_0, \omega_A \lambda_0, \omega_B \lambda_0, \omega_C \lambda_0\}$ so $i = 4$.

575 It is observed from equation 16 that $U(t)$ depends on the state of the system just after the demand situation (S_n^+), the transition rate for the aging (λ_n^i) just after the demands (i.e., T_n^+), the number of tests experienced by the safety valve after the demand situation, and the type of maintenance strategy chosen. A recursive relation is developed in Appendix B

580 4.6.2. Average Unavailability U_{avg}

With the help of equation 16, we can estimate the average unavailability for the safety valve for a mission time. The main assumption for this is that the total number of demands expected in a mission time is known by experience. We define:

- l as mission time for a safety valve
- 585 • n expected number of demands in mission time

then:

$$U_{avg} = \int_0^l U(t|T_1 = t_1, \dots, T_n = t_n) f_{T_1, \dots, T_n}(t_1, \dots, t_n) dt \quad (17)$$

4.7. Estimation of parameters of the models

In this section, we have developed an algorithm for estimating the parameters based on the maximum likelihood estimation (m.l.e) method. Let us assume that we 590 have following observation about the system:

- $X_{obs} = \{X_0, X_1, \dots, X_n\}$: denotes the n observation about the health of the system after n proof tests
- Maintenance strategy (M) selected to repair the system
- number of demands and their arrival times (T_d).

595 Then, model parameters ($\Theta = \alpha$ matrix, $\omega_A, \omega_B, \omega_C, \lambda, \lambda_u$) can be estimated using the following procedure 1.

Algorithm 1 Parameter Estimation

- 1: **procedure** $(\Theta, X_{\text{obs}}, T_d, M)$ ▷ Define inputs
2: Step 1: likelihood function: $(\mathcal{L}(\Theta))$, then By definition:

$$\mathcal{L}(\Theta) := \Pr[\Theta | X_{\text{obs}}, T_d, M] \propto \Pr[X_{\text{obs}}, T_d, M | \Theta] \quad (18)$$

$$\mathcal{L}(\Theta) = \Pr[X_0, X_1, \dots, X_n, T_d, M | \Theta]$$

(From Markov property)

$$= \Pr[X_0, T_d, M | \Theta] \cdot \Pr[X_1, T_d, M | X_0; \Theta] \cdots \Pr[X_n, T_d, M | X_{n-1}; \Theta]$$

(Note: Since each term of the previous line is a function of Θ, T_d, M)

hence the likelihood function will be some function of Θ, T_d, M , this function is denoted by \mathcal{G})

$$= \mathcal{G}(\Theta, T_d, M)$$

(19)

- 3: Step 2: Initialize the parameters with a sensible guess.
4: Step 3: Use algorithm 2 to numerical estimate the value of function \mathcal{G} .
5: Step 3: Maximize the likelihood function numerically (for $\Theta = \theta_{\text{m.l.e}}$).

Find solution of the following $\frac{\partial(\log \mathcal{G}(\Theta, T_d, M))}{\partial \Theta} = 0$

- 6: **return** $\theta_{\text{m.l.e}}$
7: **end procedure**
-

5. Numerical Results and Discussion

In this section, some numerical results are presented in order to make a sensitivity analysis of the framework proposed in Section 4. These numerical results show the interaction of the system dynamics (degradation) with external events (such as demands
600 and periodic tests) in the presence of different maintenance strategies.

Three types of systems with different fragility are chosen for the numerical analysis:

- System 3 is a representation of an almost perfect system. This system is supposed to have no degradation during a demand situation. For such a system, α
605 matrix is given by Equation 20.

$$\alpha = \begin{bmatrix} 1 & 0 & 0 & 0 \\ 0 & 1 & 0 & 0 \\ 0 & 0 & 1 & 0 \\ 0 & 0 & 0 & 1 \end{bmatrix} \quad (20)$$

- System 2 is slightly fragile system. This system may experience slight degradation due to the occurrence of a demand situation. To implement this, the α matrix is tuned in such a way that there is a 1% chance that the system may degrade to its higher degradation level when demand occurs. For such a system,
610 α matrix is given by Equation 21.

$$\alpha = \begin{bmatrix} .99 & .01 & 0 & 0 \\ 0 & .99 & .01 & 0 \\ 0 & 0 & .99 & .01 \\ 0 & 0 & 0 & 1 \end{bmatrix} \quad (21)$$

- System 1 is a more fragile system than System 2. For such a system, α matrix is given by Equation 22.

$$\alpha = \begin{bmatrix} .90 & .06 & .03 & .01 \\ 0 & .90 & .06 & .04 \\ 0 & 0 & .90 & .10 \\ 0 & 0 & 0 & 1 \end{bmatrix} \quad (22)$$

All the three types of system experience degradation caused by periodic tests as per equation 9. In the following sections, a sensitivity analysis is performed for analysis of
615 the time dependent unavailability and the average unavailability of these systems. The

provided plots give also inputs for a reflection about the flexibility of the developed framework. The framework makes it possible to take into account the effect of external shocks on the aging deterioration process. The degree of fragility of the system is an input parameter of the model.

620 *5.1. Instantaneous Unavailability for unrealistic parameters*

Figure 5 shows $U(t)$ for the system over the first five testing phases where the only one demand occurred at $T_1 = 53$ week. It can be observed that all three systems behaved similarly. All three systems have different degrees of fragility, and the instantaneous jump in the unavailability represents their response to the demand situation. When ABAO maintenance strategy is considered, it leaves residual degradation in the system even after repair. This is visible in the fourth and fifth phases where the unavailability of a more fragile system is more important even after repair since they have a higher residual degradation. The sensitivity analysis with respect to the

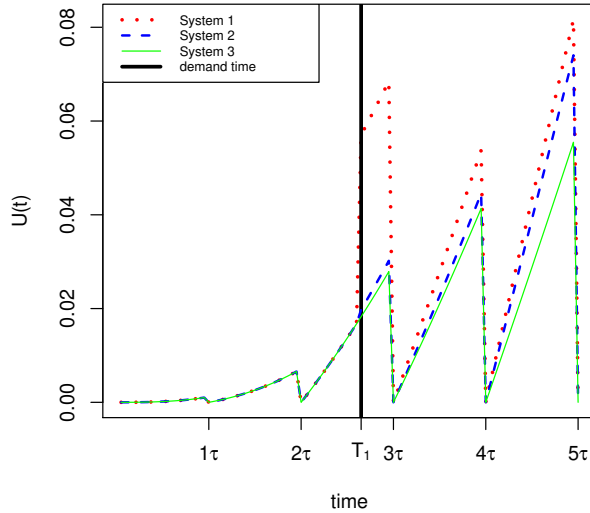

Figure 5: Time dependent Unavailability

number of demands is shown in Figure 6. In this figure, three demands have occurred at $T_1 = 26$ week, $T_2 = 31$ week, $T_3 = 73$ week. It is observed that a weaker system has

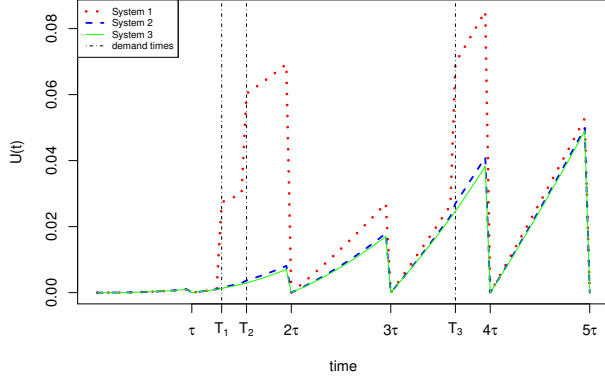

Figure 6: Time dependent Unavailability with three demands

higher unavailability when there are frequent demands. This example shows that the framework is flexible enough to handle frequent demands (i.e., two or more demands between two consecutive periodic tests) even if it is highly unlikely in a subsea environment. Figure 7 compares the effect of different maintenance strategies on System 3. It can be observed that the effect of maintenance on residual degradation becomes dominant after the second phase. Intuitively, the ABAO maintenance strategy should always have the highest unavailability. This can be verified by the plot in red. The main reason for this behaviour is that degradation caused by periodic tests accumulates in both types of maintenance strategies. This degradation increases the aging rate. However, in the AGAN maintenance strategy, the probability mass in state D is transferred to state A . In contrast, in the ABAO maintenance strategy, it is transferred to state C . Since with the ABAO strategy, the system is repaired to a degraded state, it has higher unavailability compared to when an AGAN strategy is applied. The following values of parameters are chosen $\lambda_0 = .01$ per week; $\lambda_u = .000001$ per week; $\omega_A = 1.03$, $\omega_B = 1.05$, $\omega_C = 1.07$, $\epsilon = 1.01$, $\tau = 20$ weeks. These parameters are chosen to show the overall sensitivity of the framework for the small number of testing phases. For the parameters space pertaining to Oil & Gas domain, similar behavior can be observed with higher numbers of testing phases.

Figure 8 shows a comparison between two systems that have the same immediate response to a demand situation but different susceptibility towards residual degra-

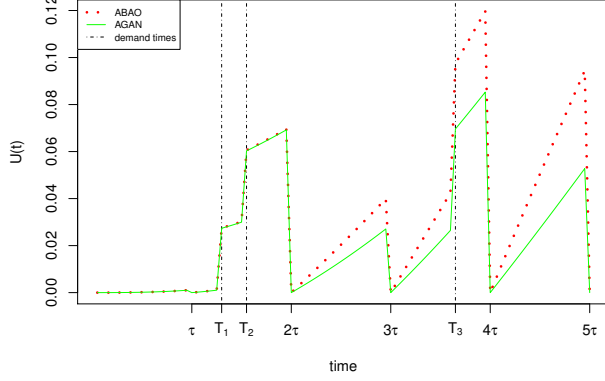

Figure 7: Time dependent Unavailability for different maintenance strategy

dation caused by the demands. This is achieved by keeping the same α matrix and different values of the set $(\omega_A, \omega_B, \omega_C)$. Intuitively, a system that is more prone to experience demands situation will have higher unavailability. The same can be verified by figure 8. System 3* in red plot has $(\omega_A = 1.15, \omega_B = 1.2, \omega_C = 1.25)$ whereas
655 System 3 in green plot has $(\omega_A = 1.015, \omega_B = 1.02, \omega_C = 1.025)$.

5.2. U_{avg} for case study

In this subsection, the average unavailability (U_{avg}) for the use-case of safety valves in an all-electric actuation system is estimated. In order to study the impact of frequent demands on U_{avg} , the following parameters are chosen based on the available literature
660 $\lambda_0 = .04 \times 10^{-6}$ per hour; $\tau = 720$ hours [22]. We assume the mission time (l) to be 5 years, $\lambda_u = .004 \times 10^{-6}$ per hour, $\epsilon = 1.01, \omega_A = 1.03, \omega_B = 1.05, \omega_C = 1.07$. Average unavailability is estimated for the three systems of different fragility as defined by equations (22), (21), (20). Table 3 shows the estimates for U_{avg} over mission time for System 1, System 2, and System 3. Since the demands follow a HPP, the expected
665 arrival time of i^{th} demand can be calculated by equation 23, where N_d is the total demand expected in the mission time l .

$$E[T_i] = i * \frac{l}{(N_d + 1)} \quad (23)$$

Then, to estimate the unconditional U_{avg} , Equation 17 is modified by Equation

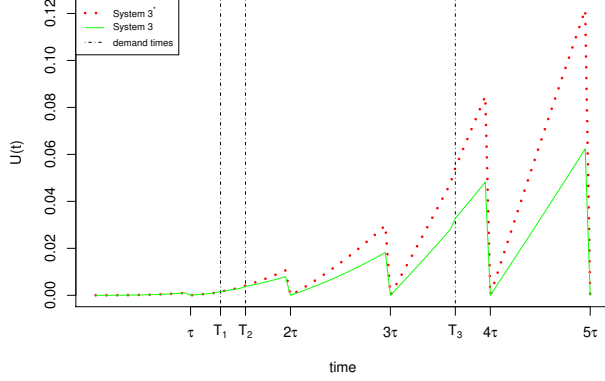

Figure 8: Time dependent Unavailability for different demand situations

24:

$$\begin{aligned}
 U_{\text{avg}}(l) = & \int_0^{E[T_1]} U(t)dt + \int_{E[T_1]}^{E[T_2]} U(t|T_1 = E[T_1])dt \dots \\
 & + \int_{E[T_{N_d}]}^l U(t|T_1 = E[T_1], \dots, T_{N_d} = E[T_{N_d}])dt
 \end{aligned} \tag{24}$$

U_{avg} is estimated in Table 3 for a different number of demands experienced in
670 a mission time. It is important to note that the ABAO maintenance strategy is
considered during the periodic testing. AGAN is not considered as it is an expensive
maintenance strategy. System 1, being the most fragile system, has the highest U_{avg}
over the mission time and System 3, being close to the ideal system, has the lowest
 U_{avg} for the same number of demands. System 3 is close to ideal, then it should not be
675 affected by the frequent demands, and U^{avg} should stay the same for various demands.
The reason for such a behaviour is that the residual degradation is accounted for by
increasing transition rates with the factor of $\omega_A, \omega_B, \omega_C$. The frequent experience of
demand increases the residual degradation, and the aging rate increases significantly.
This, in turn, results in higher U_{avg} with the increasing number of demands. Another
680 important observation comes by comparing the estimates for System 2 and System
3. By definition, System 2 has only 1% chance of degradation, but over the mission
time, the estimate for U_{avg} changes significantly from System 3, which has no chance of
immediate degradation. This comparison suggests strongly the need for this framework
for realistic estimate U_{avg} and associated risk.

Table 3: Effect of number of demands on avg Unavailability for use-case

Type of System	Number of demands					
	0	1	2	3	4	5
System 1	1.44E-06	1.94E-04	7.75E-04	1.63E-03	2.76E-03	4.10E-03
System 2	1.44E-06	1.45E-06	7.86E-05	2.29E-04	4.49E-04	7.38E-04
System 3	1.44E-06	1.44E-06	6.39E-06	1.31E-05	2.08E-05	2.91E-05

685 **6. Conclusion and Future recommendation**

6.1. Conclusion

A new framework is developed to assess the realistic performance of a safety valve of an all-electric actuation system when it is subjected to frequent demands. It is based on the consideration that experience of frequent demands may induce immediate or residual deterioration in the safety valve, which in turn interferes with the degradation process. The effect of different maintenance strategies is also shown on the performance of the safety valve. This framework extends the traditional binary state models by considering intermediate degraded states. The transition rate modeling the degradation due to age is modeled as a function of all external events experienced until the current time. The dependence on external events like periodic proof tests is considered as constant, whereas external events like demands are condition-based. Such a framework could be used as well for constructive control. It means that the external events are control commands and can somehow improve either the state of the system (by changing α matrix) or improves the aging rate (by setting condition like $\omega_A \leq 1, \omega_B \leq 1, \omega_C \leq 1, \epsilon \leq 1$).

As of now, the framework is developed under the assumption that degradation remains hidden during the entire mission time. Failures are detected only by periodic proof tests. This assumption introduces an additional level of stochastic nature in the transition rates, which results in a tree structure of possible combinations for transition rates and system states.

6.2. Future Recommendations

The framework proposed in this paper is an attempt to quantify the effect of frequent demands on the degradation of the safety valves. The framework provides a

sensitivity analysis for the estimated average unavailability on a novel technology that
710 is all-electric subsea actuation systems. If the operator provides an estimate for **the**
average number of demands experienced by the system in the mission time, the frame-
work can be utilized to find **an** optimum number of proof tests **that** will minimize the
average unavailability over the mission time. **In these cases, the quantum of reduction**
of the average unavailability against the increase in testing costs is a particular area for
715 **further research.** The proposed framework needs to be improved to remove assump-
tions (i) there is only one failure mode (DU in this case), (ii) there is negligible repair
time. The framework needs be extended to include the redundant structures which
are commonly used for safety valves (in the framework only one out of one system is
considered). Another vital assumption made while developing the framework is that
720 the impact of demands (given by α matrix) is independent of time. It seems more
practical to claim that α matrix should be dependent on the age of the system. By
this way of modeling, the phenomena that older safety valves will be more prone to
degradation while experiencing a demand can be addressed. The current framework
will need slight modifications to address this phenomenon. At last, the framework
725 currently assumes a constant impact (ϵ) on **the** aging rate due to harmful periodic
tests. This assumption also needs to be challenged to encompass some practical situa-
tions. In this next step of improvement, a condition-based impact of periodic tests in
the presence of frequent demand can be introduced. The developed framework puts
no restriction on the demand rate, so ideally, it can be used for **the** continuous mode
730 of operation also. However, slight modifications might be required as failure is self
announcing in **the** continuous mode of operation.

To conclude, **the** introduction of degradation modeling techniques in the existing
framework helps address **the** realistic degradation phenomenon a novel safety system
735 may experience. This introduction also provides a more realistic assessment of **the**
safety capabilities of such systems.

7. Acknowledgment

This paper has been written under the Norwegian Centre for Research-based In-
novation on Subsea Production and Processing (SUBPRO). **The authors would like**

740 to thank the Research Council of Norway and the industrial partners involved in this project.

Appendix A. System's dynamics evolution for three or more consecutive demands

745 In this section, we develop an algorithm to show how the framework can be utilized to calculate the system's dynamic evolution, when system is subjected n demands. We represent state probability at $t = 0$ by μ_0 ; demand times are given by T_1, T_2, \dots, T_n ; and μ_t represents the state probabilities at time t .

Algorithm 2 Generalization of system's dynamic evolution

```

1: procedure  $(\mu_0, T_1, T_2, \dots, T_n, t)$  ▷ Define initial parameters
2:   if  $t \in [0, T_1)$  then
3:     Step 1: Solve equation 10 to get  $\mu_t$ 
4:   end if
5:   if  $t \in [T_1, T_2)$  then
6:     Step 2: Perform following procedure:
7:     ⇒ calculate  $\mu(T_1^-)$  (from Step 1)
8:     ⇒ Get  $\mu(T_1^+)$  by solving equation 6
9:     ⇒ Find  $\mu_t$  by solving 10 and 11
10:  end if
11:  ⋮
12:  if  $t \in [T_{(n-1)}, T_n)$  then
13:    Step n: Perform following procedure:
14:    ⇒ calculate  $\mu(T_{(n-1)}^-)$  (from Step 1, Step 2 ...Step (n-1))
15:    ⇒ Get  $\mu(T_{(n-1)}^+)$  by solving equation 6
16:    ⇒ Find  $\mu_t$  by solving 10 and 11
17:  end if
18:  return  $\mu_t$ 
19: end procedure

```

Appendix B. Recursive Relationship

In this section, recursive relationship has been developed. For the concise notation, some short forms are defined as shown in the table B.4:

Sr	Mathematical Quantity	Short-Notation
1	$[1, 0, 0, 0], [1, 0, 0, 0]^\top$	r_A, v_A
2	$[0, 1, 0, 0], [0, 1, 0, 0]^\top$	r_B, v_B
3	$[0, 0, 1, 0], [0, 0, 1, 0]^\top$	r_C, v_C
4	$[0, 0, 0, 1], [0, 0, 0, 1]^\top$	r_D, v_D
5	$\mathcal{F}(T_n, T_{n-1}, \tau, k_{n-1}, M, \lambda, \epsilon)$	$\mathcal{F}_n(\lambda)$

Table B.4: Short Notation of Mathematical Quantities

750

$$\begin{aligned}
& \bullet \Pr[\Lambda_n^+ = \lambda_n^i; S_n^+ = A] \\
&= \sum_{s \in \{A, B, C, D\}} \Pr[\Lambda_n^+ = \lambda_n^i; S_n^+ = A | \Lambda_n^+ = \lambda_n^i; S_n^- = s] \Pr[\Lambda_n^+ = \lambda_n^i; S_n^- = s] \\
&= \Pr[\Lambda_n^+ = \lambda_n^i; S_n^+ = A | \Lambda_n^+ = \lambda_n^i; S_n^- = A] \Pr[\Lambda_n^+ = \lambda_n^i; S_n^- = A] \\
&= \alpha_{AA} \Pr[\Lambda_n^- = \frac{1}{\omega_A} \lambda_n^i; S_n^- = A] \\
&= \alpha_{AA} \sum_{s \in \{A, B, C, D\}} \Pr[\Lambda_n^- = \frac{1}{\omega_A} \lambda_n^i; S_n^- = A | \Lambda_n^- = \frac{1}{\omega_A} \lambda_n^i; S_{n-1}^+ = s] \Pr[\Lambda_n^- = \frac{1}{\omega_A} \lambda_n^i; S_{n-1}^+ = s] \\
&= \alpha_{AA} Pr[\Lambda_n^- = \frac{1}{\omega_A} \lambda_n^i; S_n^- = A | \Lambda_n^- = \frac{1}{\omega_A} \lambda_n^i; S_{n-1}^+ = A] \Pr[\Lambda_n^- = \frac{1}{\omega_A} \lambda_n^i; S_{n-1}^+ = A] \\
&\quad + \alpha_{AA} Pr[\Lambda_n^- = \frac{1}{\omega_A} \lambda_n^i; S_n^- = A | \Lambda_n^- = \frac{1}{\omega_A} \lambda_n^i; S_{n-1}^+ = B] \Pr[\Lambda_n^- = \frac{1}{\omega_A} \lambda_n^i; S_{n-1}^+ = B] \cdot \mathbb{1}_{\text{AGAN}} \\
&\quad + \alpha_{AA} Pr[\Lambda_n^- = \frac{1}{\omega_A} \lambda_n^i; S_n^- = A | \Lambda_n^- = \frac{1}{\omega_A} \lambda_n^i; S_{n-1}^+ = C] \Pr[\Lambda_n^- = \frac{1}{\omega_A} \lambda_n^i; S_{n-1}^+ = C] \cdot \mathbb{1}_{\text{AGAN}} \\
&\quad + \alpha_{AA} Pr[\Lambda_n^- = \frac{1}{\omega_A} \lambda_n^i; S_n^- = A | \Lambda_n^- = \frac{1}{\omega_A} \lambda_n^i; S_{n-1}^+ = D] \Pr[\Lambda_n^- = \frac{1}{\omega_A} \lambda_n^i; S_{n-1}^+ = D] \cdot \mathbb{1}_{\text{AGAN}} \\
&\text{(transition to state A is possible from any state due to AGAN)} \\
&= \alpha_{AA} r_A \mathcal{F}_n(\frac{1}{\omega_A \epsilon^{(k_n - k_{n-1})}} \lambda_n^i) v_A \Pr[\Lambda_{n-1}^+ = \frac{1}{\omega_A \epsilon^{(k_n - k_{n-1})}} \lambda_n^i; S_{n-1}^+ = A] \\
&\quad + \alpha_{AA} r_B \mathcal{F}_n(\frac{1}{\omega_A \epsilon^{(k_n - k_{n-1})}} \lambda_n^i) v_A \Pr[\Lambda_{n-1}^+ = \frac{1}{\omega_A \epsilon^{(k_n - k_{n-1})}} \lambda_n^i; S_{n-1}^+ = B] \cdot \mathbb{1}_{\text{AGAN}} \\
&\quad + \alpha_{AA} r_C \mathcal{F}_n(\frac{1}{\omega_A \epsilon^{(k_n - k_{n-1})}} \lambda_n^i) v_A \Pr[\Lambda_{n-1}^+ = \frac{1}{\omega_A \epsilon^{(k_n - k_{n-1})}} \lambda_n^i; S_{n-1}^+ = C] \cdot \mathbb{1}_{\text{AGAN}} \\
&\quad + \alpha_{AA} r_D \mathcal{F}_n(\frac{1}{\omega_A \epsilon^{(k_n - k_{n-1})}} \lambda_n^i) v_A \Pr[\Lambda_{n-1}^+ = \frac{1}{\omega_A \epsilon^{(k_n - k_{n-1})}} \lambda_n^i; S_{n-1}^+ = D] \cdot \mathbb{1}_{\text{AGAN}} \\
&\text{(Note: } \Lambda_n^- = \epsilon^{(k_n - k_{n-1})} \Lambda_{n-1}^+ \text{; effect of harmful testing)} \\
\end{aligned} \tag{B.1}$$

- $\Pr[\Lambda_n^+ = \lambda_n^i; S_n^+ = B]$

$$\begin{aligned}
&= \sum_{s \in \{A, B, C, D\}} \Pr[\Lambda_n^+ = \lambda_n^i; S_n^+ = B | \Lambda_n^+ = \lambda_n^i; S_n^- = s] \Pr[\Lambda_n^+ = \lambda_n^i; S_n^- = s] \\
&= \Pr[\Lambda_n^+ = \lambda_n^i; S_n^+ = B | \Lambda_n^+ = \lambda_n^i; S_n^- = A] \Pr[\Lambda_n^+ = \lambda_n^i; S_n^- = A] \\
&\quad + \Pr[\Lambda_n^+ = \lambda_n^i; S_n^+ = B | \Lambda_n^+ = \lambda_n^i; S_n^- = B] \Pr[\Lambda_n^+ = \lambda_n^i; S_n^- = B] \\
&\text{(transition to state B are possible only from state A and State B)} \\
&= \alpha_{BA} \Pr[\Lambda_n^+ = \lambda_n^i; S_n^- = A] + \alpha_{BB} \Pr[\Lambda_n^+ = \lambda_n^i; S_n^- = B] \\
&= \alpha_{BA} \Pr[\Lambda_n^- = \lambda_n^i; S_n^- = A] + \alpha_{BB} \Pr[\Lambda_n^- = \frac{1}{\omega_B} \lambda_n^i; S_n^- = B]
\end{aligned}$$

(B.2)

$$\begin{aligned}
& \Pr[\Lambda_n^- = \frac{1}{\omega_B} \lambda_n^i; S_n^- = B] \\
&= \sum_{s \in \{A, B, C, D\}} \Pr[\Lambda_n^- = \frac{1}{\omega_B} \lambda_n^i; S_n^- = B | \Lambda_n^- = \frac{1}{\omega_B} \lambda_n^i; S_{n-1}^+ = s] \Pr[\Lambda_n^- = \frac{1}{\omega_B} \lambda_n^i; S_{n-1}^+ = s] \\
&= \Pr[\Lambda_n^- = \frac{1}{\omega_B} \lambda_n^i; S_n^- = B | \Lambda_n^- = \frac{1}{\omega_B} \lambda_n^i; S_{n-1}^+ = A] \Pr[\Lambda_n^- = \frac{1}{\omega_B} \lambda_n^i; S_{n-1}^+ = A] \\
&\quad + \Pr[\Lambda_n^- = \frac{1}{\omega_B} \lambda_n^i; S_n^- = B | \Lambda_n^- = \frac{1}{\omega_B} \lambda_n^i; S_{n-1}^+ = B] \Pr[\Lambda_n^- = \frac{1}{\omega_B} \lambda_n^i; S_{n-1}^+ = B] \\
&\quad + \Pr[\Lambda_n^- = \frac{1}{\omega_B} \lambda_n^i; S_n^- = B | \Lambda_n^- = \frac{1}{\omega_B} \lambda_n^i; S_{n-1}^+ = C] \Pr[\Lambda_n^- = \frac{1}{\omega_B} \lambda_n^i; S_{n-1}^+ = C] \cdot \mathbb{1}_{\text{AGAN}} \\
&\quad + \Pr[\Lambda_n^- = \frac{1}{\omega_B} \lambda_n^i; S_n^- = B | \Lambda_n^- = \frac{1}{\omega_B} \lambda_n^i; S_{n-1}^+ = D] \Pr[\Lambda_n^- = \frac{1}{\omega_B} \lambda_n^i; S_{n-1}^+ = D] \cdot \mathbb{1}_{\text{AGAN}}
\end{aligned}$$

(transition to state A is possible from any state due to AGAN)

$$\begin{aligned}
&= r_A \mathcal{F}_n \left(\frac{1}{\omega_B \epsilon^{(k_n - k_{n-1})}} \lambda_n^i \right) v_B \Pr[\Lambda_{n-1}^+ = \frac{1}{\omega_B \epsilon^{(k_n - k_{n-1})}} \lambda_n^i; S_{n-1}^+ = A] \\
&\quad + r_B \mathcal{F}_n \left(\frac{1}{\omega_B \epsilon^{(k_n - k_{n-1})}} \lambda_n^i \right) v_B \Pr[\Lambda_{n-1}^+ = \frac{1}{\omega_B \epsilon^{(k_n - k_{n-1})}} \lambda_n^i; S_{n-1}^+ = B] \\
&\quad + r_C \mathcal{F}_n \left(\frac{1}{\omega_B \epsilon^{(k_n - k_{n-1})}} \lambda_n^i \right) v_B \Pr[\Lambda_{n-1}^+ = \frac{1}{\omega_B \epsilon^{(k_n - k_{n-1})}} \lambda_n^i; S_{n-1}^+ = C] \cdot \mathbb{1}_{\text{AGAN}} \\
&\quad + r_D \mathcal{F}_n \left(\frac{1}{\omega_B \epsilon^{(k_n - k_{n-1})}} \lambda_n^i \right) v_B \Pr[\Lambda_{n-1}^+ = \frac{1}{\omega_B \epsilon^{(k_n - k_{n-1})}} \lambda_n^i; S_{n-1}^+ = D] \cdot \mathbb{1}_{\text{AGAN}}
\end{aligned}$$

(Note: $\Lambda_n^- = \epsilon^{(k_n - k_{n-1})} \Lambda_{n-1}^+$; effect of harmful testing)

- $\Pr[\Lambda_n^+ = \lambda_n^i; S_n^+ = C]$

$$\begin{aligned}
&= \sum_{s \in \{A, B, C, D\}} \Pr[\Lambda_n^+ = \lambda_n^i; S_n^+ = C | \Lambda_n^+ = \lambda_n^i; S_n^- = s] \Pr[\Lambda_n^+ = \lambda_n^i; S_n^- = s] \\
&= \Pr[\Lambda_n^+ = \lambda_n^i; S_n^+ = C | \Lambda_n^+ = \lambda_n^i; S_n^- = A] \Pr[\Lambda_n^+ = \lambda_n^i; S_n^- = A] \\
&\quad + \Pr[\Lambda_n^+ = \lambda_n^i; S_n^+ = C | \Lambda_n^+ = \lambda_n^i; S_n^- = B] \Pr[\Lambda_n^+ = \lambda_n^i; S_n^- = B] \\
&\quad + \Pr[\Lambda_n^+ = \lambda_n^i; S_n^+ = C | \Lambda_n^+ = \lambda_n^i; S_n^- = C] \Pr[\Lambda_n^+ = \lambda_n^i; S_n^- = C] \\
&\quad + \Pr[\Lambda_n^+ = \lambda_n^i; S_n^+ = C | \Lambda_n^+ = \lambda_n^i; S_n^- = D] \Pr[\Lambda_n^+ = \lambda_n^i; S_n^- = D]
\end{aligned}$$

(transition to state C are possible from any state A, B, C; $\Pr[\Lambda_n^+ = \lambda_n^i; S_n^+ = C | \Lambda_n^+ = \lambda_n^i; S_n^- = D] = 0$)

$$\begin{aligned}
&= \alpha_{CA} \Pr[\Lambda_n^+ = \lambda_n^i; S_n^- = A] + \alpha_{CB} \Pr[\Lambda_n^+ = \lambda_n^i; S_n^- = B] + \alpha_{CC} \Pr[\Lambda_n^+ = \lambda_n^i; S_n^- = C] \\
&= \alpha_{CA} \Pr[\Lambda_n^- = \lambda_n^i; S_n^- = A] + \alpha_{CB} \Pr[\Lambda_n^- = \lambda_n^i; S_n^- = B] + \alpha_{CC} \Pr[\Lambda_n^- = \frac{1}{\omega_C} \lambda_n^i; S_n^- = C]
\end{aligned} \tag{B.3}$$

$$\begin{aligned}
& \Pr[\Lambda_n^- = \frac{1}{\omega_C} \lambda_n^i; S_n^- = C] \\
&= \sum_{s \in \{A, B, C, D\}} \Pr[\Lambda_n^- = \frac{1}{\omega_C} \lambda_n^i; S_n^- = C | \Lambda_n^- = \frac{1}{\omega_C} \lambda_n^i; S_{n-1}^+ = s] \Pr[\Lambda_n^- = \frac{1}{\omega_C} \lambda_n^i; S_{n-1}^+ = s] \\
&= \Pr[\Lambda_n^- = \frac{1}{\omega_C} \lambda_n^i; S_n^- = C | \Lambda_n^- = \frac{1}{\omega_C} \lambda_n^i; S_{n-1}^+ = A] \Pr[\Lambda_n^- = \frac{1}{\omega_C} \lambda_n^i; S_{n-1}^+ = A] \\
&\quad + \Pr[\Lambda_n^- = \frac{1}{\omega_C} \lambda_n^i; S_n^- = C | \Lambda_n^- = \frac{1}{\omega_C} \lambda_n^i; S_{n-1}^+ = B] \Pr[\Lambda_n^- = \frac{1}{\omega_C} \lambda_n^i; S_{n-1}^+ = B] \\
&\quad + \Pr[\Lambda_n^- = \frac{1}{\omega_C} \lambda_n^i; S_n^- = C | \Lambda_n^- = \frac{1}{\omega_C} \lambda_n^i; S_{n-1}^+ = C] \Pr[\Lambda_n^- = \frac{1}{\omega_C} \lambda_n^i; S_{n-1}^+ = C] \\
&\quad + \Pr[\Lambda_n^- = \frac{1}{\omega_C} \lambda_n^i; S_n^- = C | \Lambda_n^- = \frac{1}{\omega_C} \lambda_n^i; S_{n-1}^+ = D] \Pr[\Lambda_n^- = \frac{1}{\omega_C} \lambda_n^i; S_{n-1}^+ = D]
\end{aligned}$$

(transition to state D is also possible because of maintenance between two demands)

$$\begin{aligned}
&= \Pr[\Lambda_{n-1}^+ = \frac{1}{\omega_C \epsilon^{(k_n - k_{n-1})}} \lambda_n^i; S_n^- = C | \Lambda_{n-1}^+ = \frac{1}{\omega_C \epsilon^{(k_n - k_{n-1})}} \lambda_n^i; S_{n-1}^+ = A] \\
&\quad \cdot \Pr[\Lambda_{n-1}^+ = \frac{1}{\omega_C \epsilon^{(k_n - k_{n-1})}} \lambda_n^i; S_{n-1}^+ = A] \\
&\quad + \Pr[\Lambda_{n-1}^+ = \frac{1}{\omega_C \epsilon^{(k_n - k_{n-1})}} \lambda_n^i; S_n^- = C | \Lambda_{n-1}^+ = \frac{1}{\omega_C \epsilon^{(k_n - k_{n-1})}} \lambda_n^i; S_{n-1}^+ = B] \\
&\quad \cdot \Pr[\Lambda_{n-1}^+ = \frac{1}{\omega_C \epsilon^{(k_n - k_{n-1})}} \lambda_n^i; S_{n-1}^+ = B] \\
&\quad + \Pr[\Lambda_{n-1}^+ = \frac{1}{\omega_C \epsilon^{(k_n - k_{n-1})}} \lambda_n^i; S_n^- = C | \Lambda_{n-1}^+ = \frac{1}{\omega_C \epsilon^{(k_n - k_{n-1})}} \lambda_n^i; S_{n-1}^+ = C] \\
&\quad \cdot \Pr[\Lambda_{n-1}^+ = \frac{1}{\omega_C \epsilon^{(k_n - k_{n-1})}} \lambda_n^i; S_{n-1}^+ = C] \\
&\quad + \Pr[\Lambda_{n-1}^+ = \frac{1}{\omega_C \epsilon^{(k_n - k_{n-1})}} \lambda_n^i; S_n^- = C | \Lambda_{n-1}^+ = \frac{1}{\omega_C \epsilon^{(k_n - k_{n-1})}} \lambda_n^i; S_{n-1}^+ = D] \\
&\quad \cdot \Pr[\Lambda_{n-1}^+ = \frac{1}{\omega_C \epsilon^{(k_n - k_{n-1})}} \lambda_n^i; S_{n-1}^+ = D]
\end{aligned}$$

(Note: $\Lambda_n^- = \epsilon^{(k_n - k_{n-1})} \Lambda_{n-1}^+$; effect of harmful testing)

$$\begin{aligned}
&= r_A \mathcal{F}_n \left(\frac{1}{\omega_C \epsilon^{(k_n - k_{n-1})}} \lambda_n^i \right) v_C \Pr[\Lambda_{n-1}^+ = \frac{1}{\omega_C \epsilon^{(k_n - k_{n-1})}} \lambda_n^i; S_{n-1}^+ = A] \\
&\quad + r_B \mathcal{F}_n \left(\frac{1}{\omega_C \epsilon^{(k_n - k_{n-1})}} \lambda_n^i \right) v_C \Pr[\Lambda_{n-1}^+ = \frac{1}{\omega_C \epsilon^{(k_n - k_{n-1})}} \lambda_n^i; S_{n-1}^+ = B] \\
&\quad + r_C \mathcal{F}_n \left(\frac{1}{\omega_C \epsilon^{(k_n - k_{n-1})}} \lambda_n^i \right) v_C \Pr[\Lambda_{n-1}^+ = \frac{1}{\omega_C \epsilon^{(k_n - k_{n-1})}} \lambda_n^i; S_{n-1}^+ = C] \\
&\quad + r_D \mathcal{F}_n \left(\frac{1}{\omega_C \epsilon^{(k_n - k_{n-1})}} \lambda_n^i \right) v_C \Pr[\Lambda_{n-1}^+ = \frac{1}{\omega_C \epsilon^{(k_n - k_{n-1})}} \lambda_n^i; S_{n-1}^+ = D]
\end{aligned}$$

- $\Pr[\Lambda_n^+ = \lambda_n^i; S_n^+ = D]$

$$\begin{aligned}
&= \sum_{s \in \{A, B, C, D\}} \Pr[\Lambda_n^+ = \lambda_n^i; S_n^+ = D | \Lambda_n^+ = \lambda_n^i; S_n^- = s] \Pr[\Lambda_n^+ = \lambda_n^i; S_n^- = s] \\
&= \Pr[\Lambda_n^+ = \lambda_n^i; S_n^+ = D | \Lambda_n^+ = \lambda_n^i; S_n^- = A] \Pr[\Lambda_n^+ = \lambda_n^i; S_n^- = A] \\
&\quad + \Pr[\Lambda_n^+ = \lambda_n^i; S_n^+ = D | \Lambda_n^+ = \lambda_n^i; S_n^- = B] \Pr[\Lambda_n^+ = \lambda_n^i; S_n^- = B] \\
&\quad + \Pr[\Lambda_n^+ = \lambda_n^i; S_n^+ = D | \Lambda_n^+ = \lambda_n^i; S_n^- = C] \Pr[\Lambda_n^+ = \lambda_n^i; S_n^- = C] \\
&\quad + \Pr[\Lambda_n^+ = \lambda_n^i; S_n^+ = D | \Lambda_n^+ = \lambda_n^i; S_n^- = D] \Pr[\Lambda_n^+ = \lambda_n^i; S_n^- = D] \\
&\text{(transition to state D are possible from any state)} \\
&= \alpha_{DA} \Pr[\Lambda_n^+ = \lambda_n^i; S_n^- = A] + \alpha_{DB} \Pr[\Lambda_n^+ = \lambda_n^i; S_n^- = B] \\
&\quad + \alpha_{DC} \Pr[\Lambda_n^+ = \lambda_n^i; S_n^- = C] + \alpha_{DD} \Pr[\Lambda_n^+ = \lambda_n^i; S_n^- = D] \\
&= \alpha_{CA} \Pr[\Lambda_n^- = \lambda_n^i; S_n^- = A] + \alpha_{CB} \Pr[\Lambda_n^- = \lambda_n^i; S_n^- = B] \\
&\quad + \alpha_{CC} \Pr[\Lambda_n^- = \frac{1}{\omega_C} \lambda_n^i; S_n^- = C] + \Pr[\Lambda_n^- = \lambda_n^i; S_n^- = D] \\
&\text{(If system is in failed state before the demand, it will not change its state; } \alpha_{DD} = 1 \text{)} \\
\end{aligned}$$

(B.4)

$$\begin{aligned}
& \Pr[\Lambda_n^- = \lambda_n^i; S_n^- = D] \\
&= \sum_{s \in \{A, B, C, D\}} \Pr[\Lambda_n^- = \lambda_n^i; S_n^- = D | \Lambda_n^- = \lambda_n^i; S_{n-1}^+ = s] \Pr[\Lambda_n^- = \lambda_n^i; S_{n-1}^+ = s] \\
&= \Pr[\Lambda_n^- = \lambda_n^i; S_n^- = D | \Lambda_n^- = \lambda_n^i; S_{n-1}^+ = A] \Pr[\Lambda_n^- = \lambda_n^i; S_{n-1}^+ = A] \\
&\quad + \Pr[\Lambda_n^- = \lambda_n^i; S_n^- = D | \Lambda_n^- = \lambda_n^i; S_{n-1}^+ = B] \Pr[\Lambda_n^- = \lambda_n^i; S_{n-1}^+ = B] \\
&\quad + \Pr[\Lambda_n^- = \lambda_n^i; S_n^- = D | \Lambda_n^- = \lambda_n^i; S_{n-1}^+ = C] \Pr[\Lambda_n^- = \lambda_n^i; S_{n-1}^+ = C] \\
&\quad + \Pr[\Lambda_n^- = \lambda_n^i; S_n^- = D | \Lambda_n^- = \lambda_n^i; S_{n-1}^+ = D] \Pr[\Lambda_n^- = \lambda_n^i; S_{n-1}^+ = D]
\end{aligned}$$

(transition to state D is also possible because of maintenance between two demands)

$$\begin{aligned}
&= \Pr[\Lambda_{n-1}^+ = \frac{1}{\epsilon^{(k_n - k_{n-1})}} \lambda_n^i; S_n^- = C | \Lambda_{n-1}^+ = \frac{1}{\epsilon^{(k_n - k_{n-1})}} \lambda_n^i; S_{n-1}^+ = A] \\
&\quad \Pr[\Lambda_{n-1}^+ = \frac{1}{\epsilon^{(k_n - k_{n-1})}} \lambda_n^i; S_{n-1}^+ = A] \\
&\quad + \Pr[\Lambda_{n-1}^+ = \frac{1}{\epsilon^{(k_n - k_{n-1})}} \lambda_n^i; S_n^- = C | \Lambda_{n-1}^+ = \frac{1}{\epsilon^{(k_n - k_{n-1})}} \lambda_n^i; S_{n-1}^+ = B] \\
&\quad \Pr[\Lambda_{n-1}^+ = \frac{1}{\epsilon^{(k_n - k_{n-1})}} \lambda_n^i; S_{n-1}^+ = B] \\
&\quad + \Pr[\Lambda_{n-1}^+ = \frac{1}{\epsilon^{(k_n - k_{n-1})}} \lambda_n^i; S_n^- = C | \Lambda_{n-1}^+ = \frac{1}{\epsilon^{(k_n - k_{n-1})}} \lambda_n^i; S_{n-1}^+ = C] \\
&\quad \Pr[\Lambda_{n-1}^+ = \frac{1}{\epsilon^{(k_n - k_{n-1})}} \lambda_n^i; S_{n-1}^+ = C] \\
&\quad + \Pr[\Lambda_{n-1}^+ = \frac{1}{\epsilon^{(k_n - k_{n-1})}} \lambda_n^i; S_n^- = C | \Lambda_{n-1}^+ = \frac{1}{\epsilon^{(k_n - k_{n-1})}} \lambda_n^i; S_{n-1}^+ = D] \\
&\quad \Pr[\Lambda_{n-1}^+ = \frac{1}{\epsilon^{(k_n - k_{n-1})}} \lambda_n^i; S_{n-1}^+ = D]
\end{aligned}$$

(Note: $\Lambda_n^- = \epsilon^{(k_n - k_{n-1})} \Lambda_{n-1}^+$; effect of harmful testing)

$$\begin{aligned}
&= r_A \mathcal{F}_n \left(\frac{1}{\epsilon^{(k_n - k_{n-1})}} \lambda_n^i \right) v_D \Pr[\Lambda_{n-1}^+ = \frac{1}{\epsilon^{(k_n - k_{n-1})}} \lambda_n^i; S_{n-1}^+ = A] \\
&\quad + r_B \mathcal{F}_n \left(\frac{1}{\epsilon^{(k_n - k_{n-1})}} \lambda_n^i \right) v_D \Pr[\Lambda_{n-1}^+ = \frac{1}{\epsilon^{(k_n - k_{n-1})}} \lambda_n^i; S_{n-1}^+ = B] \\
&\quad + r_C \mathcal{F}_n \left(\frac{1}{\epsilon^{(k_n - k_{n-1})}} \lambda_n^i \right) v_D \Pr[\Lambda_{n-1}^+ = \frac{1}{\epsilon^{(k_n - k_{n-1})}} \lambda_n^i; S_{n-1}^+ = C] \\
&\quad + r_D \mathcal{F}_n \left(\frac{1}{\epsilon^{(k_n - k_{n-1})}} \lambda_n^i \right) v_D \Pr[\Lambda_{n-1}^+ = \frac{1}{\epsilon^{(k_n - k_{n-1})}} \lambda_n^i; S_{n-1}^+ = D]
\end{aligned}$$

755 **References**

- [1] M. Theobald, C. Lindsey-Curran, et al., Benefits of all-electric subsea production control systems, in: Offshore Technology Conference, Offshore Technology Conference, 2005.
- [2] D. Abicht, G.-R. Halvorsen, R. M. Ramberg, et al., Subsea all-electric, in: 760 Offshore Technology Conference, Offshore Technology Conference, 2017.
- [3] R. MacKenzie, G.-R. Halvorsen, H. Vedeld, et al., Subsea all electric—a game changing technology going forward, in: Offshore Technology Conference, Offshore Technology Conference, 2020.
- [4] E. Winther-Larssen, D. Massie, K. G. Eriksson, et al., Subsea all electric technology: Enabling next generation field developments, in: Offshore Technology 765 Conference, Offshore Technology Conference, 2016.
- [5] A. Wilson, et al., All-electric subsea well brings benefits vs. traditional hydraulic technology, *Journal of Petroleum Technology* 70 (2018) 65–66.
- [6] T. Myhrvold, P. Lovegrove, Subsea all electric is here to stay, ??? URL: <https://www.dnv.com/to2030/technology/subsea-all-electric-is-here-to-stay.html>. 770
- [7] D. N. Veritas, Dnv-rp-a203: Qualification of new technology, DNV Offshore Standards (2011).
- [8] R. Magtaggart, Technology qualification: Recommended practice for subsea applications, 775 *OIL & GAS JOURNAL* (2012) 38–41.
- [9] API, 17n, recommended practice for subsea production system reliability and technical risk management, American Petroleum Institute, Washington, DC (2009).
- [10] API, 17q, subsea equipment qualification-standardized process for documentation, first edition, American Petroleum Institute, Washington, DC (2010). 780
- [11] R. Bell, Iec 61508-functional safety of electrical/electronic/programme electronic safety-related systems: Overview, in: Control of Major Accidents and Hazards

Directive (COMAH)-Implications for Electrical and Control Engineers (Ref. No. 1999/173), IEE Colloquium, IET, 2016, pp. ,5–1.

- 785 [12] K. Bond, Iec 61511-functional safety: Safety instrumented systems for the process industry sector, in: Annual Symposium on Instrumentation for the Process Industries, volume 57, Instrument Society Of America, 2017, pp. ,33–40.
- [13] V. S. Halvorsen, E. Koren, et al., All electric subsea tree system development, in: Offshore Technology Conference, Offshore Technology Conference, 2008.
- 790 [14] S. Wu, L. Zhang, M. A. Lundteigen, Y. Liu, W. Zheng, Reliability assessment for final elements of siss with time dependent failures, Journal of Loss Prevention in the Process Industries 51 (2018) 186–199.
- [15] E. Rogova, G. Lodewijks, M. A. Lundteigen, Analytical formulas of pfd and pfh calculation for systems with nonconstant failure rates, Proceedings of the
795 Institution of Mechanical Engineers, Part O: Journal of Risk and Reliability 231 (2017) 373–382.
- [16] J. Salonen, P. Auerkari, O. Lehtinen, M. Pihkakoski, Experience on in-service damage in power plant components, Engineering Failure Analysis 14 (2007) 970–977.
- 800 [17] B. O. Lydell, Pipe failure probability—the thomas paper revisited, Reliability Engineering & System Safety 68 (2000) 207–217.
- [18] S. Y. Choi, J. Lee, J.-E. Yang, An analysis for risk impact of emergency diesel generator on modified surveillance test interval by considering failure due to demand stress, Nuclear Engineering and Design 240 (2010) 3577–3581.
- 805 [19] Y. Bai, Q. Bai, Subsea engineering handbook, Gulf Professional Publishing, 2018.
- [20] M. Glaser, C. Mahler, Fail-safe functionality on subsea x-mass trees without utilization of mechanical spring, in: Underwater Technology Conference, Bergen, Norway, 2017.
- [21] M. Glaser, C. Mahler, Functional safety in all-electric control systems, 2018. URL: <https://www.sut.org/wp-content/uploads/2018/10/>
810

Carsten-Markus-SCDUC-OneSubsea-C_Mahler-and-Aalen-University-M_Glaser_final.pdf.

- 815 [22] C. Mahler, M. Glaser, S. Schoch, S. Marx, S. Schluess, T. Winter, J. Popp, S. Imle, et al., Safety capability of an all-electric production system, in: Offshore Technology Conference, Bergen, Norway, 2019.
- [23] Y. Misumi, Y. Sato, Estimation of average hazardous-event-frequency for allocation of safety-integrity levels, *Reliability Engineering & System Safety* 66 (1999) 135–144.
- 820 [24] S. Martorell, P. Martorell, A. I. Sánchez, R. Mullor, I. Martón, Parameter estimation of a reliability model of demand-caused and standby-related failures of safety components exposed to degradation by demand stress and ageing that undergo imperfect maintenance, *Mathematical Problems in Engineering* 2017 (2017).
- 825 [25] P. Martorell, I. Martón, A. Sánchez, S. Martorell, Unavailability model for demand-caused failures of safety components addressing degradation by demand-induced stress, maintenance effectiveness and test efficiency, *Reliability Engineering & System Safety* 168 (2017) 18–27.
- [26] A. Zhang, H. Srivastav, A. Barros, Y. Liu, Study of testing and maintenance strategies for redundant final elements in sis with imperfect detection of degraded state, *Reliability Engineering & System Safety* 209 (2021) 107393.
- 830 [27] A. Zhang, T. Zhang, A. Barros, Y. Liu, Optimization of maintenances following proof tests for the final element of a safety-instrumented system, *Reliability Engineering & System Safety* 196 (2020) 106779.
- 835 [28] D. Colombo, G. B. A. Lima, D. R. Pereira, J. P. Papa, Regression-based finite element machines for reliability modeling of downhole safety valves, *Reliability Engineering & System Safety* 198 (2020) 106894.
- [29] A. Lemoine, M. Wenocur, On Failure Modeling. Revised., Technical Report, **FORD AEROSPACE AND COMMUNICATIONS CORP PALO ALTO CA WESTERN DEVELOPMENT LABS DIV**, 1984.
- 840 [30] N. D. Singpurwalla, Survival in dynamic environments, *Statistical science* (1995) 86–103.

- [31] E. Deloux, B. Castanier, C. Bérenguer, Predictive maintenance policy for a gradually deteriorating system subject to stress, *Reliability Engineering & System Safety* 94 (2009) 418–431.
- [32] W. Li, H. Pham, An inspection-maintenance model for systems with multiple competing processes, *IEEE transactions on reliability* 54 (2005) 318–327.
- [33] A. Lehmann, Joint modeling of degradation and failure time data, *Journal of Statistical Planning and Inference* 139 (2009) 1693–1706.
- [34] Z. Wang, H.-Z. Huang, Y. Li, N.-C. Xiao, An approach to reliability assessment under degradation and shock process, *IEEE Transactions on Reliability* 60 (2011) 852–863.
- [35] K. T. Huynh, I. T. Castro, A. Barros, C. Bérenguer, Modeling age-based maintenance strategies with minimal repairs for systems subject to competing failure modes due to degradation and shocks, *European journal of operational research* 218 (2012) 140–151.
- [36] K. T. Huynh, A. Barros, C. Berenguer, I. T. Castro, A periodic inspection and replacement policy for systems subject to competing failure modes due to degradation and traumatic events, *Reliability Engineering & System Safety* 96 (2011) 497–508.
- [37] I. Castro, An age-based maintenance strategy for a degradation-threshold-shock-model for a system subjected to multiple defects, *Asia-Pacific Journal of Operational Research* 30 (2013) 1350016.
- [38] I. Castro, N. C. Caballé, C. Pérez, A condition-based maintenance for a system subject to multiple degradation processes and external shocks, *International Journal of Systems Science* 46 (2015) 1692–1704.
- [39] N. C. Caballé, I. Castro, C. Pérez, J. M. Lanza-Gutiérrez, A condition-based maintenance of a dependent degradation-threshold-shock model in a system with multiple degradation processes, *Reliability Engineering & System Safety* 134 (2015) 98–109.

- [40] A. Valor, F. Caleyo, L. Alfonso, D. Rivas, J. Hallen, Stochastic modeling of pitting corrosion: a new model for initiation and growth of multiple corrosion pits, *Corrosion science* 49 (2007) 559–579.
- [41] I. T. Castro, A. Barros, A. Grall, Age-based preventive maintenance for passive components submitted to stress corrosion cracking, *Mathematical and Computer Modelling* 54 (2011) 598–609.
- [42] W. Li, H. Pham, Statistical maintenance modeling for complex systems, *Springer Handbook of Engineering Statistics* (2006) 807–833.
- [43] C. Teresa Lam, R. H. Yeh, Optimal replacement policies for multistate deteriorating systems, *Naval Research Logistics (NRL)* 41 (1994) 303–315.
- [44] M. Ohnishi, H. Kawai, H. Mine, An optimal inspection and replacement policy for a deteriorating system, *Journal of applied probability* 23 (1986) 973–988.
- [45] H. Pham, A. Suprasad, R. Misra, Availability and mean life time prediction of multistage degraded system with partial repairs, *Reliability Engineering & System Safety* 56 (1997) 169–173.
- [46] H. Pham, A. Suprasad, R. B. Misra, Reliability and mttf prediction of k-out-of-n complex systems with components subjected to multiple stages of degradation, *International journal of systems science* 27 (1996) 995–1000.
- [47] A. Lisnianski, G. Levitin, *Multi-state system reliability: assessment, optimization and applications*, volume 6, World Scientific Publishing Company, 2003.
- [48] M. C. Segovia, P.-E. Labeau, Reliability of a multi-state system subject to shocks using phase-type distributions, *Applied mathematical modelling* 37 (2013) 4883–4904.
- [49] S. Eryilmaz, Assessment of a multi-state system under a shock model, *Applied Mathematics and Computation* 269 (2015) 1–8.
- [50] Y.-H. Lin, Y.-F. Li, E. Zio, Integrating random shocks into multi-state physics models of degradation processes for component reliability assessment, *IEEE Transactions on Reliability* 64 (2014) 154–166.

- [51] H. Srivastav, A. Barros, M. A. Lundteigen, Modelling framework for performance analysis of sis subject to degradation due to proof tests, *Reliability Engineering & System Safety* 195 (2020) 106702.
- 900 [52] H. Srivastav, A. Guilherme, A. Barros, M. Lundteigen, F. Pedersen, A. Hafver, F. Oliveira, Optimization of periodic inspection time of sis subject to a regular proof testing, in: *Safety and Reliability–Safe Societies in a Changing World*, CRC Press, 2018, pp. ,1125–1131.
- [53] M. Rausand, *Reliability of safety-critical systems, Theory and Applications*; John
905 Wiley & Sons, Inc.: Hoboken, NJ, USA (2014).
- [54] J. V. Bukowski, Modeling and analyzing the effects of periodic inspection on the performance of safety-critical systems, *IEEE Transactions on Reliability* 50 (2001) 321–329.
- [55] Y. Wang, M. Rausand, Reliability analysis of safety-instrumented systems operated in high-demand mode, *Journal of Loss Prevention in the Process Industries*
910 32 (2014) 254–264.
- [56] Y. Liu, Discrimination of low-and high-demand modes of safety-instrumented systems based on probability of failure on demand adaptability, *Proceedings of the Institution of Mechanical Engineers, Part O: Journal of Risk and Reliability*
915 228 (2014) 409–418.
- [57] A. G. King, Sil determination: Recognising and handling high demand mode scenarios, *Process Safety and Environmental Protection* 92 (2014) 324–328.
- [58] A. HAFVER, L. F. OLIVEIRA, F. B. PEDERSEN, Optimal scheduling of tests of safety systems, considering test-induced degradation (2019).