



HAL
open science

Flow Induced by Dual-Turbine of Different Diameters in a Gas-Liquid Agitation System: the Agitation and Turbulence Indices

Daniel Garcia-Cortes, Catherine Xuereb, Patricia Taillandier, Ulises Javier Jáuregui Haza, Joël Bertrand

► To cite this version:

Daniel Garcia-Cortes, Catherine Xuereb, Patricia Taillandier, Ulises Javier Jáuregui Haza, Joël Bertrand. Flow Induced by Dual-Turbine of Different Diameters in a Gas-Liquid Agitation System: the Agitation and Turbulence Indices. *International Journal of Chemical Reactor Engineering*, 2006, 4 (1), pp.1-12. 10.2202/1542-6580.1322 . hal-04310459

HAL Id: hal-04310459

<https://hal.science/hal-04310459>

Submitted on 27 Nov 2023

HAL is a multi-disciplinary open access archive for the deposit and dissemination of scientific research documents, whether they are published or not. The documents may come from teaching and research institutions in France or abroad, or from public or private research centers.

L'archive ouverte pluridisciplinaire **HAL**, est destinée au dépôt et à la diffusion de documents scientifiques de niveau recherche, publiés ou non, émanant des établissements d'enseignement et de recherche français ou étrangers, des laboratoires publics ou privés.

Flow Induced by Dual-Turbine of Different Diameters in a Gas-Liquid Agitation System: the Agitation and Turbulence Indices

Daniel Garcia-Cortes* Catherine Xuereb[†] Patricia Taillandier[‡]
Ulises J. Jauregui-Haza** Joel Bertrand^{††}

*Center of Pharmaceutical Chemistry, daniel.garcia@infomed.sld.cu

[†]Laboratoire de Genie Chimique CNRS, Catherine.Xuereb@ensiacet.fr

[‡]Laboratoire de Génie Chimique. INP-ENSIACET, Patricia.Taillandier@ensiacet.fr

**Center of Pharmaceutical Chemistry, ulises.jauregui@infomed.sld.cu

^{††}ENSIACET, Joel.Bertrand@ensiacet.fr

Flow Induced by Dual-Turbine of Different Diameters in a Gas-Liquid Agitation System: the Agitation and Turbulence Indices

Daniel Garcia-Cortes, Catherine Xuereb, Patricia Taillandier, Ulises J. Jauregui-Haza, and Joel Bertrand

Abstract

Flow induced by a dual turbine stirred tank was characterized measuring local velocities with a LDV and drawing the main velocity fields and the maps of turbulence intensities. The hydrodynamic regime studied in all the experiments was the so-called merging flow regime. Two impeller configurations were studied. In the first one, two disk style turbine of the same dimensions (configuration A) were used, while in the second one, the dimensions of the upper turbine were 20 % proportionally smaller than those of the lower turbine (configuration B). The agitation and turbulence indices were used to evaluate, as a first order approximation, the power consumption distribution between convective and turbulent flows. The comparison of the two-phase agitation systems studied showed that configuration B seems to be more efficient than configuration A, since both induce a similar global convective flow, but the first one assures a significant reduction of power consumption. The distribution of power consumption between convective and turbulent flows was evaluated using the agitation index and a new global parameter: turbulence index.

KEYWORDS: dual-impeller, disk style turbine, agitation index, turbulence index, LDV, gas-liquid

1. INTRODUCTION

The gas – liquid dispersion process in stirred tanks with standard geometry, equipped with a ring sparger and dual-turbine agitation system, where the liquid height is larger than the tank diameter ($H > T$) has been widely reported (Abrardi, *et al.*, 1988; Hudcova, *et al.*, 1989; Roman & Gavrilesco, 1994; Vasconcelos *et al.*, 1998). However, in the literature is scarce the experimental data concerning aeration-agitation system with all the following characteristics: a) $H = T$ (Kuboi & Nienow, 1982), b) baffles fixed away from the wall and the bottom, c) tanks with curved bottom (Bouaifi & Roustan, 1998), and d) dual-turbine impellers. This geometrical configuration is common in laboratory and pilot scale bioreactors (Garcia-Cortes *et al.*, 2004). In our knowledge, configuration system with two disk turbines with the upper impeller smaller than the lower one has not been before studied.

The flows generated in stirred tanks with $H = T$ provided with dual – impeller agitation systems of $D = T/3$ were studied by Rutherford *et al.* (1996). They identified three stable flow patterns: parallel, merging and diverging. Studying these flow patterns, Mahmoudi (1994) determined that the merging flow pattern led to a mixing time lower by around 20 % compared to the two others patterns. This make the merging flow pattern more attractive for mixing operations. Taking into account this fact, the impeller configuration selected in this work guarantees the presence of the merging flow pattern in the stirred tank.

In the aeration – agitation systems with dual impellers the power drawn by the lower impeller is smaller than the power drawn by the upper one because of the direct influence of the gas flow from the sparger over the lower impeller (Kuboi & Nienow, 1982). One way to achieve similar power consumption in both impellers is reducing the dimensions of the upper impeller. The aims of this work were to establish the liquid flow patterns in the two – phase system with the upper impeller smaller than the lower one and to analyse the overall energy distribution between convective and turbulence flows by means of calculation of the agitation index and a new global parameter called turbulence index.

2. EXPERIMENTAL

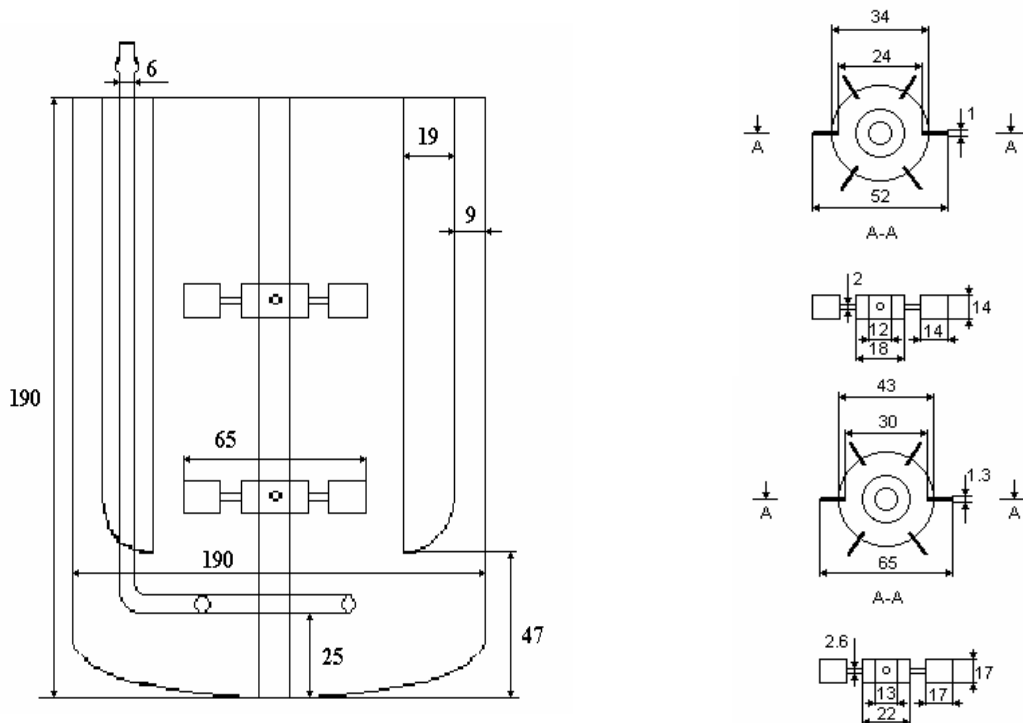

Figure 1. Aeration – agitation system.

The experiments were performed in a curved bottomed cylindrical tank with internal diameter of $T = 0.19$ m and a radii of bottom curvature of 0.19 m (Figure 1). The mean diameter of the ring sparger was 0.042 m. The sparger was located with a bottom clearance of $0.13 T$. The reactor was filled with water until $H = T$ and sparged with air at $8.7 \cdot 10^{-5} \text{ m}^3/\text{s}$ (1 vvm). The diameters of the disk style turbines used in these experiments were 0.065 and 0.052 m. In the studied agitation systems the turbines were positioned with a similar bottom and impeller clearance equal to $1/3 T$. The vessel was placed inside a transparent square tank, filled with water, in order to minimize refraction at the cylindrical surface during the measurements of local velocities in a grid of 5×11 . The measurements were performed in the vertical plane at 45° between the baffles. The radial and axial velocities were measured with a two-beam Dantec Fiberflow system operating in a backscattering mode. Seeding was found to be necessary; for this purpose, small amount of Iridium 111 (Merck) particles was added to the contents of the vessel.

The torque on the agitator shaft was also measured by a torque-measuring coupler (Staiger and Mohilo; precision 0.2 %) mounted on the agitator shaft (Baudou, 1997). This experimental value of torque was corrected for friction losses using measurements performing in an empty vessel and was then used to calculate the power consumption. The experiments were conducted at a Reynolds number (Re) of 52 500, corresponding to an impeller rotational speed of 500 ± 1 rpm. More details about the equipment and the methodology of measurements can be found elsewhere (Mavros *et al.*, 1996).

3. RESULTS AND DISCUSSION

3.1 Mean Velocity Vector Fields and Turbulence Maps

The map of velocity vectors obtained from the velocity measurements in the single liquid phase system with two disk style turbines of the same dimensions (configuration A) is shown in Figure 2a. The two characteristic ring vortices of this kind of systems are observed here. However, the results obtained differ from that reported in Kuboi & Nienow (1982) and Hudcova *et al.* (1989), where the impeller streams follow an almost straight-line orientation toward one another until they merge at an elevation approximately midway between the impellers. In this agitation system the stream from the lower impeller is not observed and the upper ring vortices of both impellers seem to be fused, forming one vortex with the centre in the midway between the impellers. The sense of fluid rotation of this vortex corresponds with the usual sense of the upper vortex in agitation systems provided with a turbine impeller. This situation presupposes a predominance of the lower impeller on the upper one during the interaction between both impellers. The lower vortex of the upper impeller is reduced and located near the shaft, between the impellers. This structure variation of the merging flow pattern may arise due to the specific combination of the baffles position and the curved bottom form used in this work, and it remains to be evaluated whether other configuration reveals a similar behaviour.

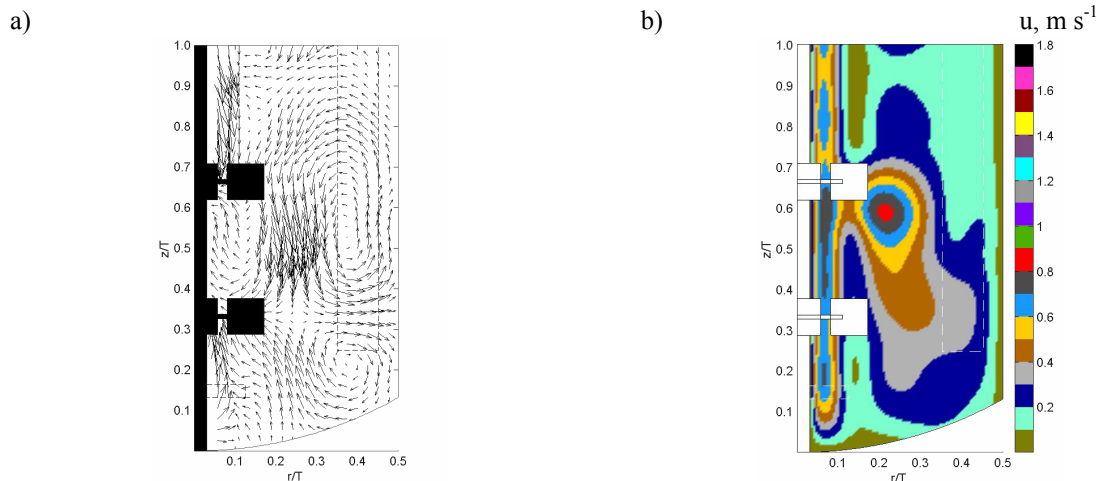

Figure 2. Measurements in the plane $r - z$, midway between the baffles in the single liquid phase agitation system with dual – impellers of the same dimensions: a) 2–D map of mean velocity vectors, b) Contours of three component fluctuating velocities.

Four focus of maximum turbulence are observed in the turbulence map (Figure 2b). This result differs from that reported by Rutherford *et al.* (1996), who found two focuses of turbulences near the impeller tips in the region between the impellers. In general there is a more organized flow in the lower half of the tank and more turbulent near the upper impeller tip and in the vicinity of the impeller shaft.

Characteristic mean velocity vectors in the same agitation system, but in a two-phase gas-liquid system, are shown in Figure 3a. The vector plots presented show an increase of the disorganization of the flow compare with the single phase system. It can be observed the disorganization of the lower vortex structure and the deformation of the upper vortex. It seems like the upper vortex is broken in two vortexes, one “open vortex” located between the impellers and the second vortex formed in the upper part of the vessel, near the wall.

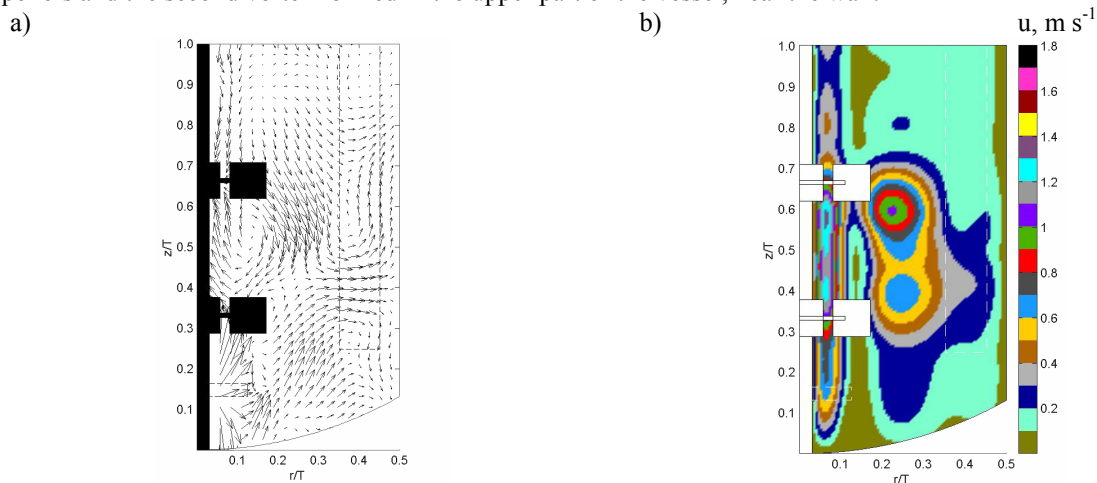

Figure 3. Measurements in the plane $r - z$, midway between the baffles in the two – phase gas –liquid agitation system with dual – impellers of the same dimensions: a) 2–D map of mean velocity vectors, b) Contours of three component fluctuating velocities.

The liquid circulation vortex situated between the impellers becomes more remarkable, presumably helped by the bubbles that ascend next to the shaft from one impeller to another. In Figure 3b it is possible to note turbulence intensification in this region and near the impeller tips.

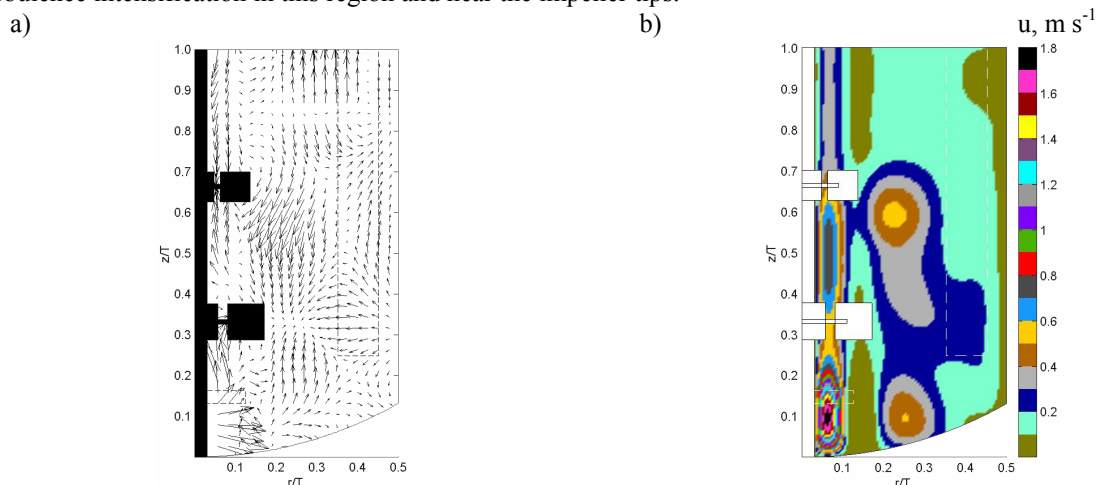

Figure 4. Measurements in the plane $r - z$, midway between the baffles in the two – phase gas –liquid agitation system with dual – impellers of different dimensions: a) 2–D map of mean velocity vectors, b) Contours of three component fluctuating velocities.

The LDV measurements in the same previous two-phase aeration-agitation system, where the upper impeller dimensions were diminished in 20 % with regard to the lower impeller (configuration B), are shown in Figure 4. This modification caused a drastic change in the flow pattern, in such a way that it is not possible to

identify any vortex in the vertical plane at 45° between baffles (Figure 4a). In the turbulence map of this system (Figure 4b), there are four maxima of turbulence intensity which are located by order of importance: under the sparger, between the impellers near the shaft, near the lower part of the upper impeller tip, and near the bottom of the vessel. In comparison with the aeration-agitation system with both impellers of the same dimensions (Figure 3b), the turbulence maximum in this agitation system (Figure 4b) is higher, although the other turbulence maxima are weaker.

3.2 Quality of Agitation

Turbulence flow has been defined by different authors (Hinze, 1959; Davies, 1972; Tennekes and Lumley, 1972; Bradshaw, 1975; Lesieur, 1990). According to Davies's definition: "as the flow rate is increased, the flow becomes unsteady, with chaotic movements of parts of the liquid in different directions superimposed on the main flow of the liquid. Such movement of any particular element of fluid is very complicated, and it can only be described in terms of averages". Baldyga and Bourne (1999) pointed out that the main flow may be identified with the flow described by the average velocity and that the chaotic movements of fluid elements are equivalent to the turbulent fluctuations of velocity (turbulent flow), interpreted as the local instantaneous values minus the average one. In this way, the convection flow generated by the impeller may be identified with the main flow and the turbulence flow with the fluctuating velocities in order to study the performance of impellers (Zhou and Kresta, 1996).

To assess the quality of agitation of single phase and two-phase gas–liquid systems described previously, two global parameters were used, the agitation and turbulence indices. These parameters allow quantify objectively the extent of mixing (macromixing and micromixing) achieved in the stirred vessel based on LDV velocity measurements.

The agitation index (I_g), defined by Mavros and Baudou (1997), represents the global mean velocity expressed as a percentage of the tip velocity:

$$I_g = \frac{\hat{U}}{U_{tip}} 100 [\%] \quad (1)$$

where U_{tip} is the agitator tip velocity and \hat{U} is the volume weighted average velocity.

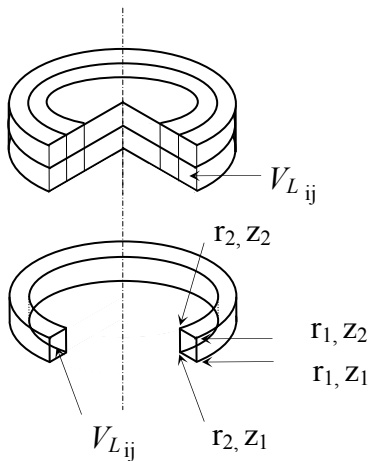

Figure 5. Illustration of part of the volume grid of the stirred tank. An example of 3-D cell of liquid volume.

The principal movements of the fluid inside the vessel are studied using most often 2-D velocity measurements, although it is well known that this flow is 3-D. Nevertheless, Mavros and Baudou (1997) demonstrated that it is possible to use this reduced sets of data, if comparisons are made consistently among agitation indices obtained with 2-D velocities. In this way, the volume weighted average velocity was determined following the postulate that each composite mean local 2-D (U_{ij}) velocity corresponds to a 3-D cell with a liquid volume, which is related to the vessel dimensions and the grid point coordinates (Figure 5):

$$\hat{U} = \frac{\sum_i \sum_j V_{L,ij} U_{ij}}{\sum_i \sum_j V_{L,ij}} \quad (2)$$

The denominator in Equation (2) corresponds approximately to a vessel volume minus the volume swept by the agitator (calculation methodology of $V_{L,ij}$ published in Mavros

and Baudou, 1997). The composite mean local 2-D velocity for each grid point (g_{ij}) was calculated using measurements of the components of mean local velocities ($V_{ij,k}$) carried out with the LDV:

$$U_{ij} = \left(\sum_k V_{ij,k}^2 \right)^{1/2}, k = r, z \quad (3)$$

The turbulence index (I_t) is a new global parameter proposed by Garcia-Cortes (2003) to quantify the magnitude of the turbulent flow in the agitation system. The procedure to calculate this index is similar to the one proposed for I_g . First, the composite root mean square (r.m.s.) local 2-D velocities (U_{ij}^*) for each grid point (g_{ij}) is calculated using LDV measurements of the components of r.m.s. local velocities ($u_{ij,k}$):

$$U_{ij}^* = \left(\sum_k u_{ij,k}^2 \right)^{1/2}, k = r, z \quad (4)$$

Further, a volume – weighted average r.m.s. velocity was determined following a similar postulate, that each such composite r.m.s. velocity (U_{ij}^*) corresponds to a volume of liquid (V_{Lij}), which is related to the vessel dimensions and the grid point coordinates:

$$\hat{U}^* = \frac{\sum_i \sum_j V_{Lij} U_{ij}^*}{\sum_i \sum_j V_{Lij}} \quad (5)$$

where the denominator corresponds approximately to the vessel volume excluding the agitator-swept region. Finally, expressing this volume – average r.m.s. velocity as a percentage of the agitator tip velocity (U_{tip}) yield the turbulence index.

$$I_t = \frac{\hat{U}^*}{U_{tip}} 100 [\%] \quad (6)$$

The turbulence index represents the global r.m.s. velocity and gives a global measure of the turbulence intensity in the vessel bulk, contrary to the parameter turbulence intensity, which is a local parameter that represents a relative measure of the fluctuations of the local velocity.

The agitation index obtained in the single phase system with dual-turbines of the same diameters ($D = T/3$) (Table 1) was compared with the value of this parameter ($I_g(rz) = 14.5 \%$) reported by Mavros and Baudou (1997). This last report was done for a single phase agitation system too, obtained in the same experimental setup, with the following geometrical configuration: four baffles positioned without clearance to the bottom and to the wall; and a single Rushton turbine with a diameter of $D = T/2$ located with a clearance to the bottom of $T/3$.

Table 1. Flow distribution between convective and turbulent flows.

Systems	Dimensions of the two impellers (configuration)	$I_g, \%$	$I_t, \%$	P, W
Single phase	Equal (configuration A)	10.6	15.1	4.2
Two-phase	Equal (configuration A)	8.4	14.4	2.8
Two-phase	Different (configuration B)	8.8	11.8	1.8

The value of the agitation index reported by Mavros and Baudou for the one-impeller system is greater than the value obtained in this work for the dual-impeller system. This is presumably due to the important influence of the

impeller diameter ($D = T/2$) on main flow that, in turn, determines that the average convective flow in an agitation system with a single impeller is greater than in the dual-impeller system.

The agitation index calculated for configuration A, but in the two-phase gas – liquid system showed a decrease of the convective flow in 21 %. This result was expected taking into account the decrease of the energy input caused by formation of the air cavities behind the turbine blades. However, the reduction of the upper impeller dimensions in 20 % with regard to the lower one, in the same two-phase system, did not cause a significant variation of the agitation index, and hence, of the convective flow.

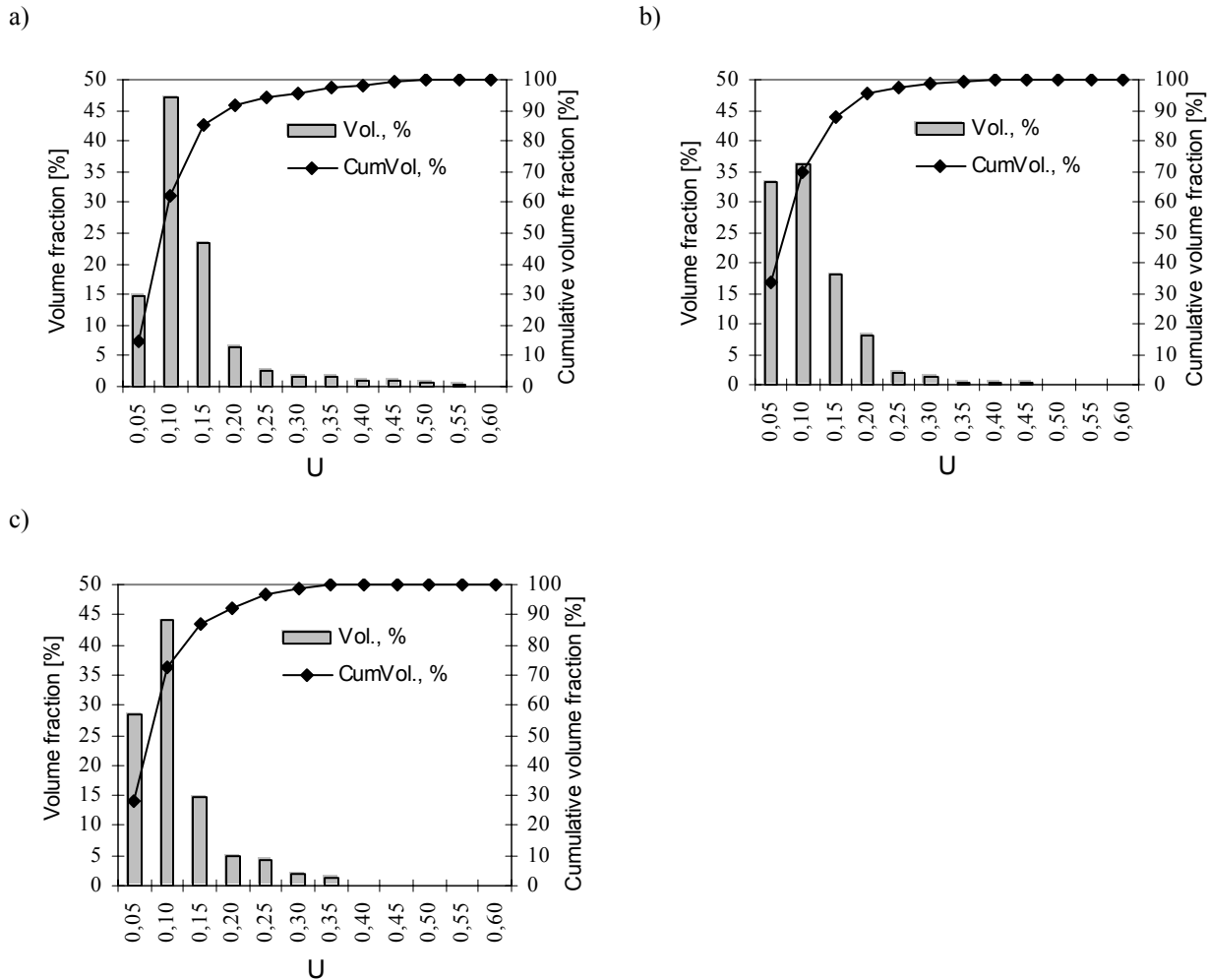

Figure 6. Distribution of mean velocity-related vessel volumes a) single liquid phase system with configuration A; b) two – phase gas – liquid system with configuration A; c) two – phase gas – liquid system with configuration B.

The distribution of liquid volumes related to specific mean velocity subranges, in the same way proposed by Mavros and Baudou (1997), is shown in the Figure 6. In the single liquid phase system (Figure 6a), near 60 % of the liquid volume, excluding the agitator-swept region, flows with an average velocity lower than $0.1 U_{tip}$, while in this agitation system with an aeration of 1 vvm, this volume fraction increases until 70 %. However, in the same two – phase system when the dimensions of the upper impeller were reduced in 20 % with regard to the lower one, the liquid volume fraction that flows with an average velocity lower than $0.1 U_{tip}$ is also of ~ 70 %, while the distribution profile resembles more to the distribution profile of the single phase system with dual impellers of the same dimensions.

The turbulence index was calculated in the studied agitation systems by means of Equations 4 – 6 (Table 1). The inclusion of a second phase in the agitation system with configuration A caused a slight decrease of the turbulent flow. However, the reduction of the dimensions of the upper impeller in 20 % with regard to the lower one in the two-phase gas – liquid system produce a diminution of the turbulent flow in 18 %.

The distribution of liquid volumes related to specific r.m.s. velocity subranges is shown in the Figure 7. In agitation systems, while more narrow is this distribution, more homogeneous is the turbulence in the vessel bulk. In this way, comparing the graphics corresponding to the three studied systems, it can be concluded that the turbulence is more homogeneous in the two-phase systems with impellers of different dimensions.

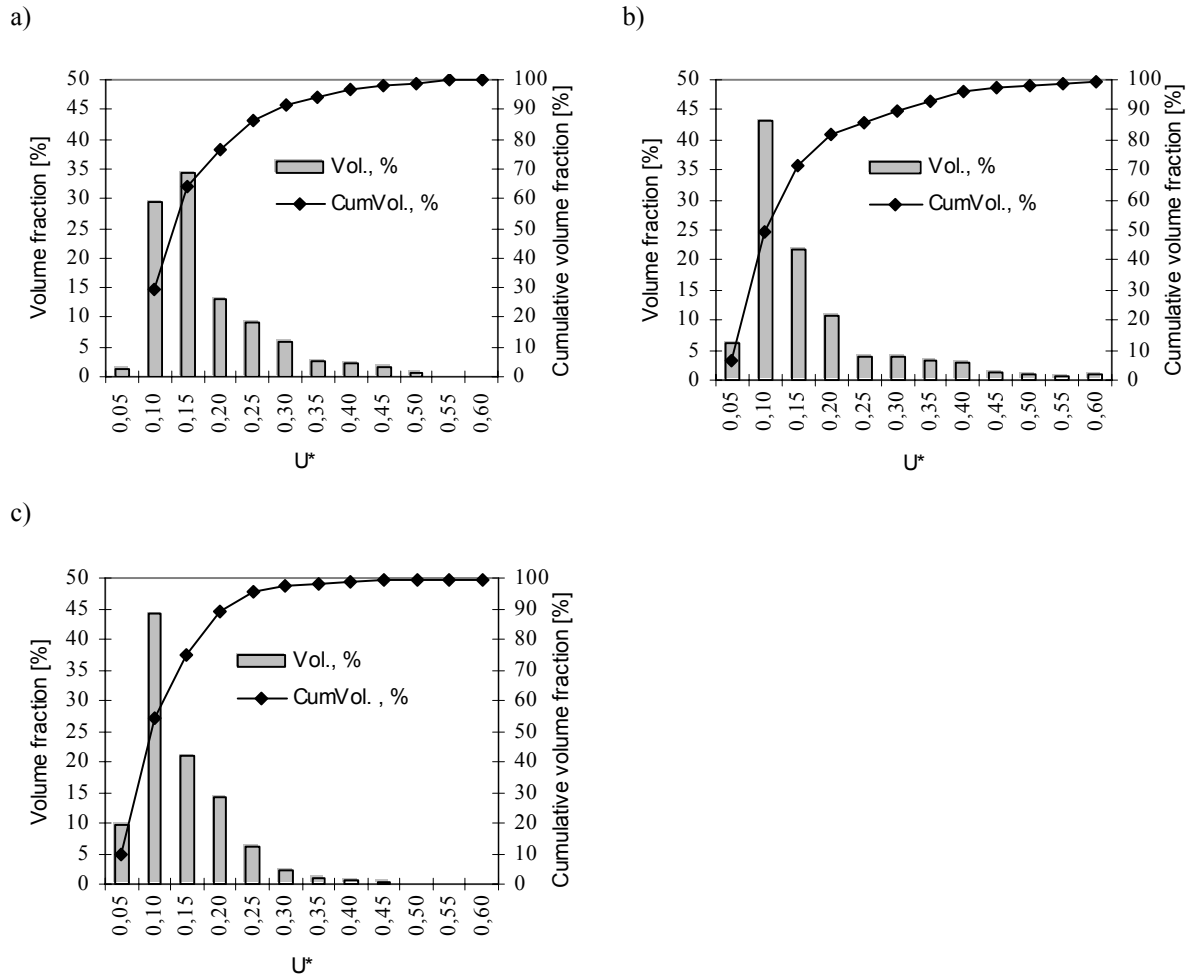

Figure 7. Distribution of r.m.s. velocity-related vessel volumes a) single liquid phase system with configuration A; b) two – phase gas – liquid system with configuration A; c) two – phase gas – liquid system with configuration B.

3.3 Energy distribution between convective and turbulent flows

Zhou and Kresta (1996) determined the way in which the impellers distribute energy between convective and turbulent flows using the macroscopic energy balance equation applied to the control volumes. Nevertheless, they remarked that efforts to extend this analysis to regions of the tank far removed from the impeller were not successful.

As a first order approximation of energy distribution in the bulk volume of the tank between convective and turbulent flows, we propose to use the agitation and turbulence indices that are global parameters. For example, as

was analysed previously, the decrease of the energy input caused by formation of air cavities behind the turbine blades is reflected by the agitation index and more slightly by turbulence index (for the turbulence the reduction of power consumption caused by aeration is partly compensated by the turbulent kinetic energy that the gas expansion transfers to the liquid).

However, the decrease of power consumption due to reduction of the upper impeller dimensions, in the same two-phase system, no caused a significant diminution of the agitation index, and hence, of the global convective flow. In this case the occurrence of the flow pattern variation (Figure 3 and 4) led to a variation of the power consumption distribution between convective and turbulent flow where evidently the decrease of power consumption has been at the expense of the decrease of the global turbulent flow reflected in the diminution of the turbulence index.

Finally, from the comparison of the two gas-liquid agitation systems studied (Table 1), it can be concluded that the system with two disk style turbine with six square blades where the upper impeller is smaller than the lower one is more appropriate for processes where it is important the fluid circulation in the vessel, since it induces an average convective flow in the bulk of the reactor similar to that induced by the agitation system with both impellers of the same dimensions, but with a smaller energy consumption (~36 %).

4. CONCLUSIONS

The flow patterns induced by dual – impeller agitation systems in a non-standard vessel have been established from laser Doppler velocimetry in a liquid and gas – liquid systems. In addition, a dual – turbine system with the upper impeller smaller than the lower one was characterized in a gas – liquid system. This hydrodynamic study allowed to draw the fields of velocity vectors and the maps of turbulence intensity in the vessel bulk of the three studied agitation systems, as well as to evaluate the distribution of the power consumption between convective and turbulent flows by means of two global parameters, the agitation and turbulence indices.

The comparison of the two-phase agitation systems studied showed that the system with two disk turbines with the upper impeller smaller than the lower one seems to be more efficient than the agitation system with the impellers of the same dimensions, since both induce a similar global convective flow, but the first one assures a significant reduction of power consumption.

ACKNOWLEDGEMENTS

DGC would like to acknowledge ALFA program project for the award of the fellowship that made this work possible.

NOTATION

D	turbine diameter, m
g	grid point
H	liquid height, m
I_g	agitation index, %
I_t	turbulence index, %
Re	$=\rho ND^2/\mu$, Reynold's number, dimensionless
T	tank diameter, m
U	composite mean local 2-D velocity, $m\ s^{-1}$
u	r.m.s. local velocity, $m\ s^{-1}$
\hat{U}	volume weighted average velocity, $m\ s^{-1}$
U^*	composite fluctuating local 2-D velocity, $m\ s^{-1}$
\hat{U}^*	volume – weighted average r.m.s. velocity, $m\ s^{-1}$

U_{tip} agitator tip velocity, m s^{-1}
 V_L liquid volume, m^3
 V mean local velocity, m s^{-1}

Indices

i, j indices of cell volumes
r radial coordinate
z axial coordinate

REFERENCES

- Abrardi, V., Rovero, G., Sicardi, S., Baldi, G. and Conti, R., "Sparged vessels agitated by multiple turbines", Proc. 6th Eur. Conf. on Mixing, Pavia, May 24–26, Cranfield: BHRA, 329–336 (1988).
- Baudou, C., "Agitation par de systemes axiaux simples ou multi-etages. Obtention de l'hydrodynamique par velocimetrie laser à effet Doppler", Ph. D. Thesis, INP-ENSIGC, Toulouse, Francia (1997).
- Bouaifi, M., Roustan, M., "Bubble size and mass transfer coefficients in dual-impeller agitated reactor", Can. J. Chem. Eng., 76, 390–397(1998).
- Baldyga, J., Bourne, J.R., "Turbulence mixing and chemical reactions", John Wiley & Sons, Chichester (1999).
- Bradshaw, P., "Introduction to turbulence and its measurements", Pergamon Press, Oxford (1975).
- Davies, J.T., "Turbulence phenomena", Academic Press, New York (1972).
- Garcia-Cortes, D., "Contribution à l'étude de l'hydrodynamique et du transfert de masse en réacteurs de type cuve agitée par une approche globale et locale en système gas-liquide", in "Microfilm ANRT". Université Pierre Mendes, France -BP 47, 38040 Grenoble cedex 9, (2003).
- Garcia-Cortes D., Xuereb, C., Taillandier, P., Jauregui-Haza U., Bertrand, J., "Effect of dual impeller-sparger geometry on the hydrodynamics and mass transfer in stirred vessels", Chem. Eng. Tech., 27, 988–999 (2004).
- Hinze, J. O., "Turbulence", McGraw-Hill, New York (1959).
- Hudcova, V., Machon, V., Nienow, A.W., "Gas liquid dispersion with dual Rushton turbine impellers", Biotech. Bioeng., 34, 617– 628 (1989).
- Kuboi, R., Nienow, A.W., "The power drawn by dual impeller systems under gassed and ungassed conditions", Proc. 4th Europ. Conf. on Mixing, Noordwijkerhout, April 27–29, Netherlands, 247-261 (1982).
- Lesieur, M., "Turbulence in fluids", Kluwer, Dordrecht, (1990).
- Mahmoudi, S.M.S., "Velocity and mixing characteristics of stirred vessels with two impellers", Ph. D. Thesis, University of London, England (1994).
- Mavros, P., Baudou, P., "Quantification of the performance of agitators in stirred vessels: Definition and use of an agitation index", Chem. Eng. Res. Des., 75, 737–745 (1997).
- Mavros, P., Xuereb, C., Bertrand, J., "Determination of 3-D flow fields in agitated vessels by laser-Doppler velocimetry: Effect of impeller type and liquid viscosity on liquid flow patterns", Chem. Eng. Res. Des., 74, 658–668 (1996).
- Roman, R.V., Gavrilesu, M., "Hydrodynamics of a gas-liquid vessel stirred with Rushton turbines in newtonian and non-newtonian systems", Hung. J. Ind. Chem. Vesz., 22, 87 – 93 (1994).

Rutherford, K., Lee, K.C., Mahmoudi, S.M.S., Yianneskis, M., "Hydrodynamics characteristics of dual Rushton impeller stirred vessels", *AIChE J*, 42, 332–346 (1996).

Tennekes, H., Lumley, J.L., "A first course in turbulence", MIT Press, Cambridge (1972).

Vasconcelos, J.M.T., Alves, S., Nienow, A.W., Bujalski, W., "Scale-up of mixing in gassed multi-turbine agitated vessels", *Can. J. Chem. Eng.*, 76, 398–404 (1998).

Zhou, G., Kresta S.M., "Distribution of energy between convective and turbulent flow for three frequently used impellers", *Chem. Eng. Res. Des.*, 74, 379–389 (1996).