



HAL
open science

A robust fully Mixed Finite Element model for flow and transport in unsaturated fractured porous media

Anis A. Younes, Hussein Hoteit, Rainer Helmig, Marwan Fahs

► To cite this version:

Anis A. Younes, Hussein Hoteit, Rainer Helmig, Marwan Fahs. A robust fully Mixed Finite Element model for flow and transport in unsaturated fractured porous media. *Advances in Water Resources*, 2022, 166, pp.104259. 10.1016/j.advwatres.2022.104259 . hal-04300425

HAL Id: hal-04300425

<https://hal.science/hal-04300425>

Submitted on 22 Nov 2023

HAL is a multi-disciplinary open access archive for the deposit and dissemination of scientific research documents, whether they are published or not. The documents may come from teaching and research institutions in France or abroad, or from public or private research centers.

L'archive ouverte pluridisciplinaire **HAL**, est destinée au dépôt et à la diffusion de documents scientifiques de niveau recherche, publiés ou non, émanant des établissements d'enseignement et de recherche français ou étrangers, des laboratoires publics ou privés.

1
2
3
4
5
6
7
8
9
10
11
12
13
14
15
16
17
18
19
20
21
22
23
24
25
26
27
28
29
30
31
32
33
34
35
36
37

**A robust fully Mixed Finite Element model for flow and transport in
unsaturated fractured porous media**

Anis Younes¹, Hussein Hoteit², Rainer Helmig³, Marwan Fahs¹

¹ITES, University of Strasbourg, CNRS, ENGEES, 67000, Strasbourg, France.

²Physical Science and Engineering Division, King Abdullah University of Science and Technology (KAUST),
Thuwal, Saudi Arabia

³ Institute for Modelling Hydraulic and Environmental Systems, University of Stuttgart, Pfaffenwaldring 61,
70569 Stuttgart, Germany

Submitted to Advances in Water Resources

Contact author: Marwan Fahs

E-mail: fahs@unistra.fr

38 **Abstract**

39 A fully mixed finite element (MFE) model is developed for nonlinear flow and transport in
40 unsaturated fractured porous media with matrix-fracture and fracture-fracture fluid and mass
41 exchanges. The model is based on the discrete fracture matrix (DFM) approach and assumes
42 cross-flow equilibrium in the fractures. The MFE method is employed for the spatial
43 discretization of both flow and transport on the 2D-matrix elements as well as on the 1D-
44 fracture elements. An upwind scheme is employed to avoid unphysical oscillations in the case
45 of advection dominant transport. The temporal discretization is performed using high-order
46 time integration methods and efficient automatic time-stepping schemes via the MOL.

47 Two test problems dealing with flow and mass transport in saturated and unsaturated fractured
48 porous media are simulated to show the validity of the new model by comparison against (i) a
49 1D-2D Comsol finite element model and (ii) a 2D-2D Discontinuous Galerkin (DG) model
50 where both fractures and matrix continua are discretized with small 2D mesh elements. The
51 robustness and efficiency of the developed 1D-2D MFE model are then investigated for a
52 challenging problem dealing with infiltration of contaminated water into an initially dry soil
53 involving a fracture network.

54 The new model yields stable results for advection-dominated and advection-dispersion
55 transport configurations. Further, the results of the 1D-2D MFE model are in very good
56 agreement with those of the 2D-2D DG model for both configurations. The simulation of
57 infiltration of contaminated water into a dry fractured soil shows that the 1D-2D MFE model
58 is within 15 times more efficient than the 2D-2D DG model, which confirms the high benefit
59 of using robust and efficient DFM models for the simulation of flow and transport in fractured
60 porous media.

61
62 **Key words:**

63 Fractured porous media, discrete fracture matrix approach, unsaturated flow, advection-
64 dispersion equation, mixed finite element, upwind scheme.

65 **1. Introduction**

66 Flow and transport in fractured porous media are important in many applications such as
67 water resource management (Wireman 2003, Kavouri *et al.*, 2017), contaminant transport
68 (Berkowitz, 2002; Brutz and Rajaram 2017, Klammler *et al.* 2016), nuclear waste
69 management (Follin and Stigsson 2014, Mattila and Tammisto 2012) and oil and gas
70 production (Li *et al.*, 2015; Shen *et al.*, 2016).

71 The flow and transport processes in fractured porous media can be significantly affected by
72 the characteristics of the fractures, such as location, size, orientation, and aperture. The
73 fractures can be empty, or contain a filling material (Berre *et al.*, 2019). In this work, the
74 fractures are considered filled with a porous medium with different properties from the porous
75 matrix, as in Khoobor *et al.* (2020). Two approaches are commonly used for modeling flow in
76 fractured porous media (Berre *et al.*, 2019). The first approach is based on an implicit
77 representation of the fractures and includes both single-continuum and multi-continuum
78 models. In single-continuum models, the fractures are taken into account by calculating an
79 equivalent permeability of the porous medium, which depends on the properties of the
80 fractures and the fracture network (Durlafsky, 1991; Liu *et al.*, 2016). In multi-continuum
81 models, the fractured porous medium is represented by two or more superimposed media with
82 their own flow and/or transport equations. Among these, the well-known dual porosity model
83 which considers superposition of a low permeability continuum representing the matrix with a
84 high permeability continuum representing the fractures (Jourde *et al.*, 2002; Kordilla *et al.*,
85 2012). The two continua are then linked by a linear exchange term. More sophisticated multi-
86 continuum models have been developed for aquifers with high heterogeneities, such as karst

87 aquifers, to include different levels of porosities and cavities (Kuhlman *et al.*, 2015; Wu *et al.*,
88 2004).

89 The second approach uses on an explicit representation of the fractures. Among this approach,
90 the discrete fracture network (DFN) model. With DFN, the geometry and properties of
91 discrete fractures are explicitly incorporated as a central component controlling flow and
92 transport. Discrete fracture matrix (DFM) models consider that flow and transport processes
93 occur through both, the porous matrix and the explicitly represented fractures. As a
94 consequence, the DFM model is more appropriate for handling fractures in a permeable
95 porous medium (Berre *et al.*, 2019). Considering that the aperture of the fractures is small as
96 compared to the matrix scale, the main idea of DFM is to use the cross-flow equilibrium
97 concept across the fractures (Noorishad and Mehran, 1982; Baca *et al.*, 1984; Granet *et al.*,
98 1998; Hoteit *et al.*,2008). As a consequence, the fractures can be discretized with elements of
99 co-dimension one with respect to the dimension of the surrounding matrix (Flemish *et al.*,
100 2018; Martin *et al.*, 2005), such as 1D fracture elements with 2D matrix elements. This
101 simplification makes DFM models much more efficient than the single porosity 2D-2D
102 model, where 2D elements are used for both matrix and fracture continua. Note that the
103 applicability of the 2D-2D models is often hampered by their expansive computational cost
104 since they require very fine mesh elements to correctly discretize the fractures with small
105 apertures.

106 Hoteit and Firoozabadi (2005; 2006) employed DFM models assuming cross-flow
107 equilibrium between the fractures and the adjacent matrix gridcells by imposing the pressure
108 at a fracture and at the adjacent gridcells to be equal. Although efficient, this assumption still
109 requires small mesh elements next to the fractures (Hoteit and Firoozabadi, 2008). To avoid
110 this constraint, Hoteit and Firoozabadi (2008) proposed solving the flow equation with the
111 hybrid formulation of the mixed finite element (MFE) method. This formulation has the

112 pressure at the gridcell interfaces as degrees of freedom (DOF), and hence, the cross-flow
113 equilibrium can be directly assumed across the fractures (Hoteit and Firoozabadi, 2008). In
114 this way, the matrix pressure at an element edge and the pressure at the fracture, which
115 coincides with that edge, are assumed to be equal. As a consequence, no constraints are
116 required for the mesh discretization near the fractures (Hoteit and Firoozabadi, 2008). This
117 powerful feature is extended in this work by developing a fully MFE model for both
118 unsaturated flow and transport in the porous matrix and in the fracture continuum.

119 The MFE (Raviart and Thomas, 1977; Chavent and Jaffré, 1986) is a robust numerical method
120 for solving diffusion problems, which has recently received attention in geosciences. Indeed,
121 with MFEs, the flux and the pressure unknowns are approximated simultaneously. The MFE
122 method ensures local mass balance and can easily handle general unstructured meshes
123 (Younes *et al.*, 2010). Further, it yields an accurate velocity field in highly heterogeneous and
124 anisotropic media (Durlafsky, 1994). The hybridization procedure of the MFE method allows
125 improving its efficiency by reducing the total number of unknowns and producing a final
126 system with a positive symmetric definite matrix (Chavent and Jaffré, 1986). The unknowns,
127 in this case, are the traces of the variable at the edges.

128 A lumped formulation of the MFE method has been developed by Younes *et al.* (2006) to
129 improve the monotonicity of the solution and reduce the unphysical oscillations observed with
130 transient problems. Belfort *et al.* (2009) showed that the lumped formulation is more efficient
131 and more robust than the standard one for the simulation of water infiltration into initially dry
132 soils. Further, contrarily to the standard MFE method, the lumped formulation maintains the
133 time derivative continuous and thus, allows employment of high-order time integration
134 methods via the method of lines (MOL), which can be very efficient for solving nonlinear
135 problems (Fahs *et al.*, 2009 and Younes *et al.*, 2009).

136 Although the MFE method is well adapted for diffusion type equations, when applied for the
137 advection-dispersion transport equation, the solution can exhibit strong unphysical
138 oscillations because of the hyperbolic nature of the advection operator. Therefore, the main
139 objective of this work is to develop a stable MFE model for unsaturated flow and mass
140 transport through both the 2D-matrix and the 1D-fracture elements. Both fluid and
141 contaminant matrix-fracture and fracture-fracture exchanges are implicitly taken into account,
142 without using any transfer functions, even for the case of several intersecting fractures. To
143 avoid instabilities caused by the hyperbolic advection term, we use a robust monotonic
144 upwind MFE scheme where the traces of concentration at edges are upwinded depending on
145 the direction of the local velocity. An implicit scheme is used for the time discretization of the
146 flow and transport equations. This alleviates restriction on the size of the time step from the
147 CFL condition of explicit schemes. For the sake of brevity, the lumped hybrid MFE method
148 employed in this work will also be denoted MFE.

149 Modeling flow and transport in unsaturated fractured porous media is likely to be highly CPU
150 consuming due to (i) the strongly nonlinear Richards flow equation (RE), (ii) the high contrast
151 of permeability between the conductive fractures and the low permeable matrix and (iii) the
152 presence of sharp wetting and/or contaminant fronts. These difficulties make the commonly
153 used, first-order backward Euler scheme combined with the heuristic time step management,
154 inappropriate to obtain accurate solutions in a reasonable CPU time. To overcome these
155 difficulties, time integration is performed using high-order time integration methods via the
156 Method of Lines (MOL). The MOL allows versatile time step length and order of the
157 temporal discretization to reduce the computational time while maintaining accuracy. The
158 MOL was shown to be effective for the solution of the RE in the unsaturated zone (Fahs *et al*,
159 2009; Khoobor *et al.*, 2020) and is used hereafter for the first time for coupled flow and
160 transport through unsaturated fractured porous media.

161 This article is structured as follows. In section 2, we recall the nonlinear mathematical models
 162 governing flow and advection-dispersion transport processes in unsaturated porous media. In
 163 section 3, we develop a robust fully MFE formulation for the solution of flow and transport
 164 both in the porous matrix and in the fracture continuum. In section 4, numerical experiments
 165 are performed for flow and transport in saturated and unsaturated fractured porous media to
 166 investigate the validity and robustness of the new 1D-2D MFE model. Some conclusions are
 167 given in the last section of the article.

168 2. Governing Equations

169 The porous matrix is assumed permeable, and the fractures are infilled by a porous medium
 170 whose physical characteristics are different from those of the porous matrix. Flow in variably
 171 saturated porous media, both in the matrix and through the fractures, is assumed to be ruled
 172 by the mass conservation of the fluid:

$$173 \quad \frac{\partial \theta}{\partial t} = \left(c(h) + S_s \frac{\theta}{\theta_s} \right) \frac{\partial H}{\partial t} = -\nabla \cdot \mathbf{q} = 0 \quad (1)$$

174 and the Darcy-Buckingham law:

$$175 \quad \mathbf{q} = -k_r \mathbf{K} \nabla H \quad (2)$$

176 where $c(h) = \partial \theta / \partial h$ is the specific moisture capacity [L^{-1}], S_s is the specific mass storativity
 177 related to head changes [L^{-1}], θ is the current water content [$L^3 L^{-3}$], θ_s is the saturated water
 178 content [$L^3 L^{-3}$], $H = h + y$ is the freshwater head [L], h is the pressure head [L], y is the
 179 upward vertical coordinate [L], t is the time [T], \mathbf{q} is the Darcy velocity [LT^{-1}], k_r is the
 180 relative conductivity [-], $\mathbf{K} = \frac{\rho g}{\mu} \mathbf{k}$ is the hydraulic conductivity tensor [LT^{-1}], ρ is the fluid

181 density $[ML^{-3}]$, g is the gravity acceleration $[LT^{-2}]$, μ is the fluid dynamic viscosity $[ML^{-1}T^{-1}]$ and \mathbf{k} is the permeability of the rock matrix as a tensor, or that of the fracture, as a scalar
 182 $[L^2]$.

184 The transport of contaminants in the unsaturated porous matrix and through the unsaturated
 185 fractures is ruled by the advection-dispersion equation:

$$186 \quad \frac{\partial(\theta C)}{\partial t} + \nabla \cdot (\mathbf{q}C) - \nabla \cdot (\mathbf{D}\nabla C) = 0 \quad (3)$$

187 where C [-] is the relative concentration [-] and \mathbf{D} is the dispersion tensor given by:

$$188 \quad \mathbf{D} = D_m \mathbf{I} + (\alpha_L - \alpha_T) \mathbf{q} \otimes \mathbf{q} / |\mathbf{q}| + \alpha_T |\mathbf{q}| \mathbf{I} \quad (4)$$

189 In which α_L and α_T are the longitudinal and transverse dispersivities [L], D_m is the pore
 190 water diffusion coefficient $[L^2T^{-1}]$ and \mathbf{I} is the unit tensor.

191 The standard van Genuchten (van Genuchten, 1980) model is used for the relationship
 192 between water content and pressure head:

$$193 \quad S_e = \frac{\theta(h) - \theta_r}{\theta_s - \theta_r} = \begin{cases} \frac{1}{(1 + |\alpha h|^n)^m} & h < 0 \\ 1 & h \geq 0 \end{cases} \quad (5)$$

194 where α $[L^{-1}]$ and n [-] are the van Genuchten parameters, $m = 1 - 1/n$, S_e is the effective
 195 saturation [-], and θ_r is the residual water content $[L^3L^{-3}]$.

196 The conductivity-saturation relationship is analytically expressed from the Mualem (Mualem,
 197 1976) model,

198

$$k_r = S_e^{1/2} \left[1 - \left(1 - S_e^{1/m} \right)^m \right]^2 \quad (6)$$

199

200

201

202

The nonlinear system (1)-(6) is solved numerically on (i) unstructured triangular 2D elements for the porous matrix and (ii) linear 1D elements for fracture branches. All hydraulic and transport parameters in the system (1)-(6) are defined elementwise, and therefore, they can be different for each matrix or fracture element.

203

3. The fully MFE numerical model

204

205

In this session, we recall the main stages for developing a robust MFE formulation for the solution of the flow and transport equations both in the porous matrix and in the fractures.

206

3.1 Discretization of the flow equation in the porous matrix

207

208

With the MFE method, the velocity \mathbf{q} inside each triangular element E is approximated using the linear Raviart-Thomas basis functions (see Figure 1):

209

$$\mathbf{q} = \sum_{j=1}^3 Q_j^E \mathbf{w}_j^E \quad (7)$$

210

where Q_j^E is the flux across the edge ∂E_j of E and $\mathbf{w}_j^E = \frac{1}{2|E|} \begin{pmatrix} x - x_j^E \\ y - y_j^E \end{pmatrix}$ is the Raviart-

211

Thomas basis functions (Raviart and Thomas, 1977) with (x_j^E, y_j^E) the coordinates of the

212

node j faced to the edge ∂E_j of E and $|E|$ the area of E .

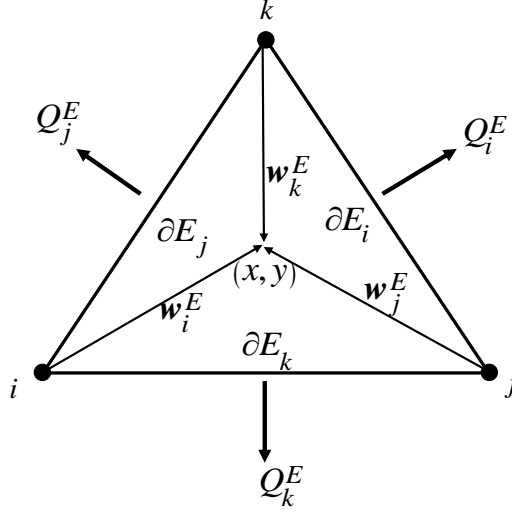

213

214 **Figure 1:** RT0 vectorial basis functions and orientation of fluxes for a 2D triangular element.

215 Using w_i^E as a test function, the variational formulation of the Darcy law Eq. (2) writes

$$216 \quad \int_E (k_r^{-1} \mathbf{K}^{-1} \mathbf{q}) \cdot \mathbf{w}_i^E = - \int_E \nabla H \cdot \mathbf{w}_i^E = \int_E H \nabla \cdot \mathbf{w}_i^E - \sum_j \int_{\partial E_j} H \mathbf{w}_i^E \cdot \boldsymbol{\eta}_j^E \quad (8)$$

217 where $\boldsymbol{\eta}_j^E$ is the outward unit normal vector to the edge E_j .

218 Defining \mathbf{B}^E the elemental matrix of terms $B_{i,j}^E = \int_E (k_r^{-1,E} \mathbf{K}^{-1,E} \mathbf{w}_j^E) \cdot \mathbf{w}_i^E$, we obtain (see

219 Younes *et al.*, 2004 for details)

$$220 \quad \mathbf{B}^E = \frac{1}{48|E|} \begin{pmatrix} 3\ell_{ij} + 3\ell_{ik} - \ell_{jk} & -3\ell_{ij} + \ell_{ik} + \ell_{jk} & \ell_{ij} - 3\ell_{ik} + \ell_{jk} \\ -3\ell_{ij} + \ell_{ik} + \ell_{jk} & 3\ell_{ij} - \ell_{ik} + 3\ell_{jk} & \ell_{ij} + \ell_{ik} - 3\ell_{jk} \\ \ell_{ij} - 3\ell_{ik} + \ell_{jk} & \ell_{ij} + \ell_{ik} - 3\ell_{jk} & -\ell_{ij} + 3\ell_{ik} + 3\ell_{jk} \end{pmatrix} \quad (9)$$

221 with $\ell_{ij} = \mathbf{r}_{ij}^T (k_r^{-1,E} \mathbf{K}^{-1,E})^{-1} \mathbf{r}_{ij}$ and \mathbf{r}_{ij} is the edge vector from the node i to the node j .

222 Using Eq. (7) and properties of \mathbf{w}_i^E , the Darcy Eq. (8) becomes

223
$$\sum_j B_{i,j}^E Q_j^E = \frac{1}{|E|} \int_E H - \frac{1}{|\partial E_i|} \int_{\partial E_i} H$$
 (10)

224
$$= H_E - TH_i^E$$

224 where H_E is the mean head at the element E and TH_i^E is the mean head at the edge ∂E_i .

225 Inverting Eq. (10) provides the water flux Q_i^E across the edge ∂E_i as

226
$$Q_i^E = \delta_i^E H_E - \sum_j B_{i,j}^{-1,E} TH_j^E$$
 (11)

227 where $\delta_i^E = \sum_j B_{i,j}^{-1,E}$.

228 The lumped formulation of MFE is then used in the following steps

- 229 • In a first step, integration of the mass conservation Eq. (1) over the element E ,
- 230 assuming a steady-state flow ($\partial\theta/\partial t = 0$) and substituting Eq. (11), yields

231
$$H_E = \sum_i \frac{\delta_i^E}{\delta^E} TH_i^E$$
 (12)

232 where $\delta^E = \sum_i \delta_i^E$

233 Hence, the steady-state flux \underline{Q}_i^E across the edge ∂E_i writes

234
$$\underline{Q}_i^E = \sum_j \left(\frac{\delta_i^E \delta_j^E}{\delta^E} - B_{i,j}^{-1,E} \right) TH_j^E$$
 (13)

- 235 • In a second step, a lumped region R_i is constructed around each edge ∂E_i by joining
- 236 the two nodes of ∂E_i to the element centers \mathbf{x}_E and $\mathbf{x}_{E'}$ of the elements E and E'
- 237 sharing the edge i (Figure 2).

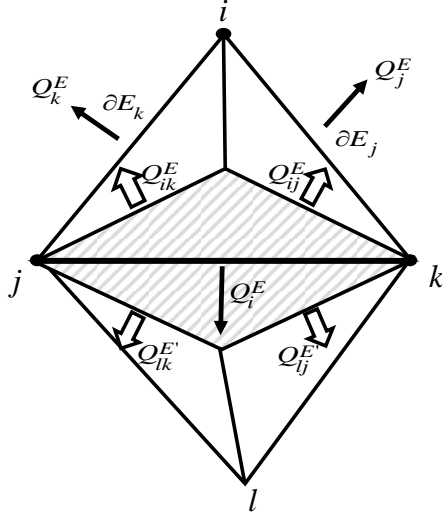

238

239 **Figure 2:** The lumping region R_i associated to the edge i sharing the elements E and E'

240 and formed by the two simplex regions S_i^E and $S_i^{E'}$.

241 The domain is now partitioned into lumping regions R_i (hatched area in Figure 2)

242 assigned to the edge i formed by the two simplex regions S_i^E and $S_i^{E'}$ for an inner

243 edge i and by the sole simplex region S_i^E for a boundary edge. The simplex region S_i^E

244 is defined by joining the centre of E with the nodes j and k forming the edge i . The

245 area of S_i^E is $\frac{|E|}{3}$.

246 • In a third step, the integration of the transient mass conservation Eq. (1) over the

247 lumped region R_i yields (see Figure 2 for notations):

248
$$\frac{|E|}{3} r_E \frac{dTH_i^E}{dt} + \frac{|E'|}{3} r_{E'} \frac{dTH_l^E}{dt} + \underline{Q}_{ij}^E + \underline{Q}_{ik}^E + \underline{Q}_{lj}^{E'} + \underline{Q}_{lk}^{E'} = 0 \quad (14)$$

249 where $r_E = c(h_E) + S_S \theta(h_E) / \theta_S$ is the accumulation coefficient in Richards'
 250 equation and \underline{Q}_{ij}^E the interior flux, evaluated using the RT0 approximation of the
 251 velocity inside the element E given by Eq. (7), which yields

$$252 \quad \underline{Q}_{ij}^E = \frac{1}{3} (\underline{Q}_j^E - \underline{Q}_i^E) \quad (15)$$

253 Substituting Eq. (13) and Eq. (15) into Eq. (14), allows to write the mass
 254 conservation Eq. (14) over the lumping regions R_i assigned to the edge i as a
 255 continuity of fluxes between two adjacent elements E and E' sharing the edge i as
 256 follows

$$257 \quad \begin{cases} Q_i^E + Q_i^{E'} = 0 \\ Q_i^E = \sum_j \left(\frac{\delta_i^E \delta_j^E}{\delta^E} - B_{i,j}^{-1,E} \right) TH_j^E - \frac{|E|}{3} r_E \frac{dTH_i^E}{dt} \end{cases} \quad (16)$$

258 The flow system is formed by Eq. (16) for all the mesh edges which do not coincide with a
 259 fracture and solved for the mean head at edges TH_i by imposing continuity of the head at the
 260 interface of the elements ($TH_i = TH_i^E = TH_i^{E'}$). The obtained system is highly nonlinear since
 261 the local matrix \mathbf{B} , and the accumulation term r depend on the pressure head. In the case of
 262 a Dirichlet condition with a prescribed head H_{imp} at the boundary edge i , Eq. (16) is replaced
 263 by $TH_i = H_{imp}$. If the boundary edge i has a prescribed flux Q_{imp} (Neumann boundary
 264 condition), Eq. (16) becomes $Q_i^E + Q_{imp} = 0$.

265 Note that, contrarily to the standard MFE method, the time derivative remains continuous in
 266 Eq. (16), which facilitates employment of high-order methods for the time discretization.

267 3.2 Spatial discretization of the flow in the presence of a fracture

268 Let's consider a fracture k of length ℓ_k and aperture e_k . The fracture k coincides with the
 269 edge i shared by the adjacent matrix-elements E and E' (see Figure 3). The flow through the
 270 fracture occurs between it's two nodes of pressures NH_1^k and NH_2^k . The flux Q_i^E
 271 (respectively $Q_i^{E'}$) represents the matrix-fracture fluid exchange between E (respectively E')
 272 and the fracture k .

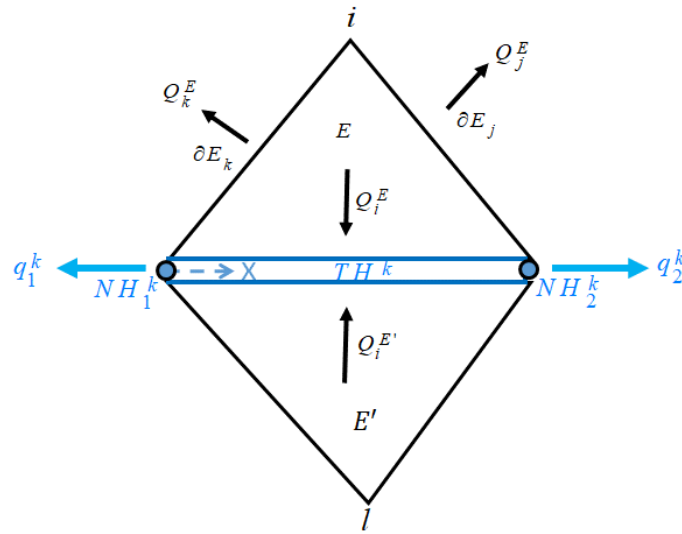

273

274 **Figure 3:** Schematic representation of the one-dimensional fracture k , which coincides with
 275 the edge i shared by the matrix elements E and E' . The flux Q_i^E (respectively $Q_i^{E'}$)
 276 represents the matrix-fracture fluid exchange between E (respectively E') and k .

277 The one-dimensional flow through the fracture k is discretized with the MFE method, which
 278 assumes a linear variation of the velocity q^k inside k ,

279
$$q^k = q_1^k w_1^k + q_2^k w_2^k \quad (17)$$

280 with $q_{j=1,2}^k$ the flux leaving the node $j=1,2$ of the fracture k , $w_1^k = \frac{x - \ell_k}{e_k \ell_k}$ and $w_2^k = \frac{x}{e_k \ell_k}$

281 are the one-dimensional velocity interpolation functions using the local coordinate $x \in [0, \ell_k]$.

282 The mass conservation Eq. (1) integrated over the fracture k of length ℓ_k and aperture e_k
 283 yields

$$284 \quad e_k \ell_k r_k \frac{dTH^k}{dt} + q_1^k + q_2^k - Q_i^E - Q_i^{E'} = 0 \quad (18)$$

285 with TH^k the mean head in the fracture k and $r_k = c(h_k) + S_S^k \frac{\theta_k}{\theta_S}$ the accumulation coefficient
 286 related to k , Q_i^E and $Q_i^{E'}$ are the water fluxes from the element E and E' representing matrix-
 287 fracture exchange.

288 The variational formulation of the Darcy law Eq. (2) on the fracture k writes

$$289 \quad \sum_j q_j^k \int_0^{\ell_k} w_i^k w_j^k = -k_r^k \mathbf{K}_f^k \int_0^{\ell_k} (\nabla H) w_i^k \quad (19)$$

290 Integration by part leads to

$$291 \quad \sum_j q_j^k \int_0^{\ell_k} w_i^k w_j^k = \frac{k_r^k \mathbf{K}_f^k}{e_k} (TH^k - NH_i^k) \quad (20)$$

292 where NH_i^k corresponds to the head at the node i located at the extremity of the fracture k .

293 Using numerical integration, based on the trapezoidal rule, for the calculation of the left term
 294 (see Koohbor *et al.*, 2020) yields

$$295 \quad q_i^k = e_k k_r^k \frac{2K_f^k}{\ell_k} (TH^k - NH_i^k) \quad (21)$$

296 The cross-flow equilibrium assumption is then employed by prescribing equality of the matrix
 297 edge head and the fracture head ($TH_i^E = TH_i^{E'} = TH^k$). Thus, substituting Eq. (21) and Eq.
 298 (16) into Eq. (18) yields

$$\begin{aligned}
 299 \quad \sum_j \left(\frac{\delta_i^E \delta_j^E}{\delta^E} - B_{i,j}^{-1,E} \right) TH_j^E + \sum_j \left(\frac{\delta_i^{E'} \delta_j^{E'}}{\delta^{E'}} - B_{i,j}^{-1,E'} \right) TH_j^{E'} - e_k k_r^k \frac{2K_f^k}{\ell_k} (2TH_i^E - NH_1^k - NH_2^k) \\
 - \left(\frac{|E|}{3} r_E + \frac{|E'|}{3} r_{E'} + e_k \ell_k r_k \right) \frac{dTH_i^E}{dt} = 0
 \end{aligned} \tag{22}$$

300 To close the system of Eq. (22), the mass conservation is written at each intersection of
 301 fracture branches. At the node i shared by k fracture branches, we impose

$$302 \quad \sum_k q_i^k = 0 \tag{23}$$

303 Using Eq. (21), we obtain

$$304 \quad \sum_k e_k k_r^k \frac{2K_f^k}{\ell_k} (TH^k - NH_i^k) = 0 \tag{24}$$

305 Finally, the global flow system is formed by Eq. (16) for all the edges which do not coincide
 306 with a fracture and by Eq. (22) else. This system is supplemented by Eq. (24) for all the nodes
 307 of the fracture branches and assuming the continuity of the head ($NH_i = NH_i^k$) at the node i ,
 308 intersection of k fracture branches. Therefore, the final flow system has the heads at the edges
 309 of the mesh plus the heads at the nodes of the fracture branches as unknowns.

310 *3.3 Discretization of the advection-dispersion transport equation in the porous matrix*

311 The transport of contaminants in the unsaturated porous matrix described by Eq. (3) writes:

312
$$C \left(\frac{\partial \theta}{\partial t} + \nabla \cdot \mathbf{q} \right) + \theta \frac{\partial C}{\partial t} + \mathbf{q} \cdot \nabla C - \nabla \cdot (\mathbf{D} \nabla C) = 0 \quad (25)$$

313 Using the fluid mass conservation Eq. (1), the transport equation can be written in the
 314 following form:

315
$$\begin{cases} \theta \frac{\partial C}{\partial t} + \mathbf{q} \cdot \nabla C + \nabla \cdot \tilde{\mathbf{q}} = 0 \\ \tilde{\mathbf{q}} = -\mathbf{D} \nabla C \end{cases} \quad (26)$$

316 The MFE method is now used for the spatial discretization of the transport equation. To this
 317 aim, the dispersion vector $\tilde{\mathbf{q}}$ is approximated inside each triangular element E with the
 318 Raviart Thomas vectorial basis functions as:

319
$$\tilde{\mathbf{q}} = \sum_j \tilde{Q}_j^E \mathbf{w}_j^E \quad (27)$$

320 where $\tilde{Q}_j^E = \int_{\partial E_j} \tilde{\mathbf{q}}_d \cdot \boldsymbol{\eta}_j^E$ is the dispersive flux across the edge ∂E_j of the element E .

321 The variational formulation of Eq. (26) is written as

322
$$\int_E (\mathbf{D}_E^{-1} \tilde{\mathbf{q}}) \cdot \mathbf{w}_i^E = - \int_E \nabla C \cdot \mathbf{w}_i^E \quad (28)$$

323 which can take the following form

324
$$\sum_j \tilde{B}_{i,j}^E \tilde{Q}_j^E = C_E - TC_i^E \quad (29)$$

325 where C_E is the mean concentration at the element E and TC_i^E is the trace of concentration
 326 at the edge ∂E_i of the element E and $\tilde{\mathbf{B}}$ is the elemental matrix of terms

327
$$\tilde{B}_{i,j}^E = \int_E (\mathbf{D}_E^{-1} \mathbf{w}_j^E) \cdot \mathbf{w}_i^E$$

328 Inverting Eq. (29) yields the dispersive flux across ∂E_i as

$$329 \quad \tilde{Q}_i^E = \sum_j \tilde{B}_{i,j}^{-1,E} (C_E - TC_j^E) \quad (30)$$

330 An upwind lumped MFE scheme is used to avoid unphysical oscillations caused by the
 331 hyperbolic advection part of the transport equation. The main steps of this scheme are as
 332 follows:

- 333 • In a first step, both advective and transient terms are removed from the first equation
 334 in the system of Eq. (26), yielding a steady-state dispersive flux $\underline{\tilde{Q}}_i^E$ expressed by
 335 (similarly to Eq. (12)):

$$336 \quad \underline{\tilde{Q}}_i^E = \sum_j \frac{\tilde{\delta}_i^E \tilde{\delta}_j^E}{\tilde{\delta}^E} TC_j^E - \sum_j \tilde{B}_{i,j}^{-1,E} TC_j^E \quad (31)$$

$$337 \quad \text{with } \tilde{\delta}_i^E = \sum_j \tilde{B}_{i,j}^{-1,E} \text{ and } \tilde{\delta}^E = \sum_i \tilde{\delta}_i^E .$$

- 338 • In a second step, the integration of the advection-dispersion equation (26) over the
 339 lumped region R_i writes (see Figure 2):

$$340 \quad \left\{ \frac{|E|}{3} \theta_E \frac{\partial TC_i^E}{\partial t} + Q_{ij}^E TC_{ij}^E + Q_{ik}^E TC_{ik}^E - (Q_{ij}^E + Q_{ik}^E) TC_i^E - \underline{\tilde{Q}}_i^E \right\} + \{ \} ' = 0 \quad (32)$$

341 where $Q_{ij}^E = \frac{1}{3} (Q_j^E - Q_i^E)$ is the interior flux between edges i and j (see Eq. (15)).

342 The interior concentration TC_{ij}^E is calculated using the upstream edge concentration
 343 as:

344
$$TC_{ij}^E = \tau_{ij}^E TC_i^E + (1 - \tau_{ij}^E) TC_j^E \quad (33)$$

345 with $\tau_{ij}^E = 1$ for an outward flux ($Q_{ij}^E \geq 0$), else $\tau_{ij}^E = 0$.

346 Thus, if we note Qt_i^E the total (advection + dispersion) flux leaving the element E
 347 from the edge i , Eq. (32) can be rewritten as the continuity of the total flux between
 348 two adjacent elements E and E' sharing the edge i as

349
$$\begin{cases} Qt_i^E + Qt_i^{E'} = 0 \\ Qt_i^E = \sum_j \left(\frac{\tilde{\delta}_i^E \tilde{\delta}_j^E}{\tilde{\delta}^E} - \tilde{B}_{i,j}^{-1,E} \right) TC_j^E + Q_{ij}^E (1 - \tau_{ij}^E) (TC_i^E - TC_j^E) + Q_{ik}^E (1 - \tau_{ik}^E) (TC_i^E - TC_k^E) - \theta_E \frac{|E|}{3} \frac{\partial TC_i^E}{\partial t} \end{cases}$$

 350 (34)

351 *3.4 Spatial discretization of the advection-dispersion transport equation through a fracture*

352 Let's consider a fracture k of length ℓ_k and aperture e_k and x the local coordinate along k
 353 with $x = 0$ at the first node of k and $x = \ell_k$ at the second node of k .

354 The diffusion coefficient D_k through the fracture k is approximated by

355
$$D_k = \alpha_L^k |\bar{q}_k| + D_m^k \quad (35)$$

356 where α_L^k is the longitudinal dispersivity through the fracture k , D_m^k is the molecular diffusion

357 through k , and $\bar{q}_k = \frac{(q_2^k - q_1^k)}{2e_k}$ is the mean velocity in the fracture k .

358 The dispersive flux $\tilde{q} = -D\nabla C$ through the fracture is approximated using the MFE method.

359 Similarly to Eq. (21), the dispersive flux \tilde{q}_i^k at the extremity $i = 1, 2$ of the fracture k writes

360
$$\tilde{q}_i^k = \frac{2e_k D_k}{\ell_k} (TC^k - N\tilde{C}_i) \quad (36)$$

361 where $N\tilde{C}_i$ is the concentration at the node i .

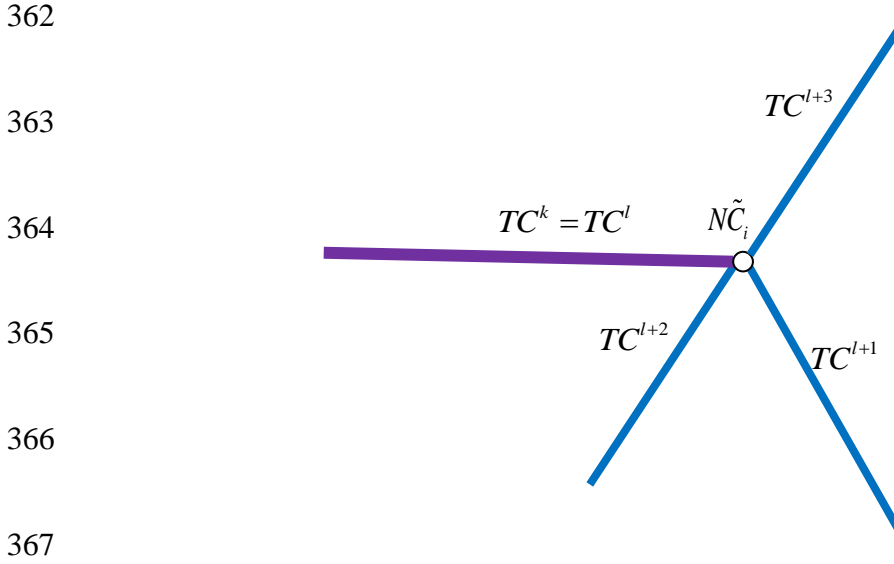

368 **Figure 4:** Intersection of multiple fracture branches.

369 Imposing the continuity of the dispersive fluxes arriving from all fracture branches sharing the
 370 node i (see Figure 4) writes

371
$$\sum_l \frac{2e_l D_l}{\ell_l} (TC^l - N\tilde{C}_i) = 0 \quad (37)$$

372 Which yields

373
$$N\tilde{C}_i = \frac{\sum_l \frac{e_l}{\ell_l} D_l TC^l}{\sum_l \frac{e_l}{\ell_l} D_l} \quad (38)$$

374 Substituting Eq. (38) into the flux Eq. (36) yields

375
$$\tilde{q}_i^k = \frac{2e_k D_k}{\ell_k} \left(TC^k - \frac{\sum_l \frac{e_l}{\ell_l} D_l TC^l}{\sum_l \frac{e_l}{\ell_l} D_l} \right) \quad (39)$$

376 The integration of the mass conservation equation over the fracture k which coincides with the
 377 edge i shared by the two matrix elements E and E' , writes

378
$$\theta_k e_k \int_0^{\ell_k} \frac{\partial C}{\partial t} + e_k \int_0^{\ell_k} \nabla \cdot (\mathbf{q}C) - e_k \int_0^{\ell_k} C \nabla \cdot \mathbf{q} + e_k \int_0^{\ell_k} \nabla \cdot \tilde{\mathbf{q}} - Q_{t_i}^E - Q_{t_i}^{E'} = 0 \quad (40)$$

379 The calculation of the different integrals yields

380
$$\theta_k e_k \ell_k \frac{\partial TC^k}{\partial t} + q_1^k C_1^{k,*} + q_2^k C_2^{k,*} - (q_1^k + q_2^k) TC^k + \tilde{q}_1^k + \tilde{q}_2^k = Q_{t_i}^E + Q_{t_i}^{E'} \quad (41)$$

381 where $C_i^{k,*}$ is the concentration at the node i of the fracture k given by

382
$$C_i^{k,*} = \lambda_i^k NC_{i,in}^k + (1 - \lambda_i^k) \overline{NC}_{i,out} \quad (42)$$

383 in which $NC_{i,in}^k = TC^k$ is the interior concentration and the parameter λ_i^k is used to select the

384 upstream concentration, it depends on the sign of q_i^k as

385
$$\lambda_i^k = \begin{cases} 1 & \text{if } q_i^k \geq 0 \\ 0 & \text{if } q_i^k < 0 \end{cases} \quad (43)$$

386 Hence, in the case of an outflow at the node i of k , the nodal concentration is $C_i^{k,*} = TC^k$,

387 whereas, in the case of an inflow at the node i of the fracture k , the nodal concentration is

388 $\overline{NC}_{i,out}$.

389 To calculate $\overline{NC}_{i,out}$, we use the contaminant conservation at the node i , shared by l fractures,
 390 which writes

$$391 \quad \sum_{k=1}^l q_i^k C_i^{k,*} = 0 \quad (44)$$

392 Using Eq. (42) and Eq. (43), we obtain

$$393 \quad \overline{NC}_{i,out} = \frac{\sum_{k=1}^l q_i^k \lambda_i^k TC^k}{\sum_{k=1}^l q_i^k (\lambda_i^k - 1)} \quad (45)$$

394 Note that the number of unknowns for the transport system to be solved does not depend on
 395 the number of fractures in the domain. Indeed, the final transport system has the concentration
 396 at edges as unknowns and is constructed as follows

397 • For all edges i sharing two matrix elements E and E' such that i does not coincide with
 398 a fracture k , Eq. (34) is solved for the unknown edge concentration TC_i assuming
 399 continuity of edge concentration ($TC_i = TC_i^E = TC_i^{E'}$).

400 • For all edges i sharing two matrix elements E and E' such that i coincides with a
 401 fracture k , Eq. (41), in which we substitute Eq. (34), Eq. (39), Eq. (42), Eq. (43) and
 402 Eq. (45), is solved for the unknown edge concentration TC_i assuming that the
 403 concentration at the edge matrix and at the fracture are equal
 404 ($TC_i = TC_i^E = TC_i^{E'} = TC^k$).

405 3.5 The temporal discretization of the nonlinear flow-transport system

406 The final nonlinear flow-transport system, formed by Eq. (16), Eq. (22), and Eq. (24) for the

407 flow and by Eq. (34) and Eq. (41) for the transport, is written in a single implicit system of
408 ordinary differential equations (ODEs) of the general form

$$409 \quad F(t, \mathbf{y}, \mathbf{y}') = 0 \quad (46)$$

410 Where $\mathbf{y} = \left[(TH_i)_{i=1, \dots, nb_edges}, (NH_i)_{i=1, \dots, nb_nodefractures}, (TC_i)_{i=1, \dots, nb_edges} \right]$ is the vector of unknowns
411 formed by (i) the head traces at all the edges of the mesh (except boundary edges with
412 prescribed head), (ii) the head at all the nodes corresponding to the extremity of fracture
413 branches, and (iii) the concentration traces at all edges of the mesh (except boundary edges
414 with prescribed concentration). Thus, the number of unknowns for the flow-transport system
415 is approximately twice the number of edges plus the number of fractures.

416 For the time discretization, we use high-order methods, which are known to be more efficient
417 and require less effort in the nonlinear solver compared to the lowest order methods (Farthing
418 *et al.*, 2002). An efficient automatic time-stepping scheme is employed to improve the
419 computational efficiency while maintaining accuracy (Tocci *et al.*, 1997; Kavetski *et al.*,
420 2001). The time integration is performed with the DASPK time solver, which uses the
421 preconditioned Krylov iterative method to solve the linear systems arising at each time step.
422 DASPK is based on the Fixed Leading Coefficient Backward Difference Formulas
423 (FLCBDF), which has good stability properties and is well adapted for time integration of
424 stiff problems (Kees and Miller, 2002). The nonlinear problem is linearized using the Newton
425 method with a numerical approximation of the Jacobian matrix. To improve efficiency, the
426 Jacobian is reused for several time steps and is calculated by the solver only when necessary.
427 Furthermore, the column grouping technique (Hindmarsh, 1982) is employed to reduce the
428 computational time for the evaluation of the Jacobian matrix by perturbing variables by
429 group, knowing the structure and sparsity of the Jacobian.

430 During calculation, the order (up to fifth order) of the time discretization and the time step
431 size are adapted to improve efficiency while the relative and absolute convergence criteria are
432 maintained under a fixed tolerance (10^{-6} in this work).

433 **4. Numerical experiments**

434 In this section, three test problems dealing with flow and mass transport in saturated and
435 unsaturated fractured porous media are simulated to investigate the robustness of the new
436 MFE code. The first test case deals with flow and transport in a saturated porous medium
437 involving a single fracture. This test case is used to validate the developed 1D-2D MFE code
438 against the solution obtained with Comsol multiphysics 1D-2D model. Comsol uses the
439 standard finite element (FE) method and an adaptive time stepping scheme. The test problem
440 is also simulated with a 2D-2D model where 2D triangular elements are employed for the
441 spatial discretization of both the matrix and the fractures continua using a very fine mesh in
442 order to correctly discretize the fracture branches with a small aperture. We use the advanced
443 2D-2D DG model developed by Younes *et al.* (2021), based on the discontinuous Galerkin
444 (DG) finite element and the multipoint flux approximation methods and high-order time
445 integration techniques via the method of lines (MOL).

446 The second test case deals with flow and transport in a fractured unsaturated-saturated porous
447 medium. The porous medium has initially wet conditions and involves a single fracture. This
448 test case is used to validate the developed 1D-2D MFE model against the solution obtained
449 with the 2D-2D DG model in the case of unsaturated flow.

450 The last test case is a challenging problem dealing with flow and transport into an initially dry
451 soil containing a fracture network. This last problem is simulated to highlight the efficiency
452 and robustness of the developed 1D-2D MFE model compared to the 2D-2D DG model.

453

454

455 *4.1 Fractured saturated quarter-five-spot problem*

456 We consider a quadratic 2D domain (quarter-five-spot configuration) of size $[0,1\text{m}] \times [0,1\text{m}]$
 457 with impermeable walls except at the lower-left and the upper-right corners. The source at the
 458 lower-left corner is represented by a boundary flux $q_{inj} = 10^{-3} \text{ m/s}$ at
 459 $(0 \leq x \leq 0.03\text{m}) \cap (y = 0) \cup (x = 0) \cap (0 \leq y \leq 0.03\text{m})$. The sink at the right-upper corner is
 460 represented by a Dirichlet boundary condition with a zero head at
 461 $(0.97\text{m} \leq x \leq 1\text{m}) \cap (y = 1) \cup (x = 1) \cap (0.97\text{m} \leq y \leq 1\text{m})$. The porous medium is formed by a
 462 homogeneous material with a diagonal fracture of 1mm aperture, located between
 463 $(0.2\text{m}, 0.2\text{m})$ and $(0.8\text{m}, 0.8\text{m})$. The hydraulic and transport properties of the porous matrix
 464 and the fracture continuum are depicted in Table 1. The initial conditions correspond to a
 465 domain free from pollutants. The simulation is performed for a time of 3456s.

466

	K_s (m/s)	S_s (1/m)	θ_s	α_L (m)	α_T (m)	D_m (m ² /s)
Matrix	10^{-6}	10^{-10}	0.4	0.0	0.0	10^{-6}
Fracture	10^{-3}	10^{-10}	0.4	0.0	0.0	10^{-6}

467

468 **Table 1:** Hydraulic and transport parameters for the fractured saturated quarter-five-spot
 469 problem.

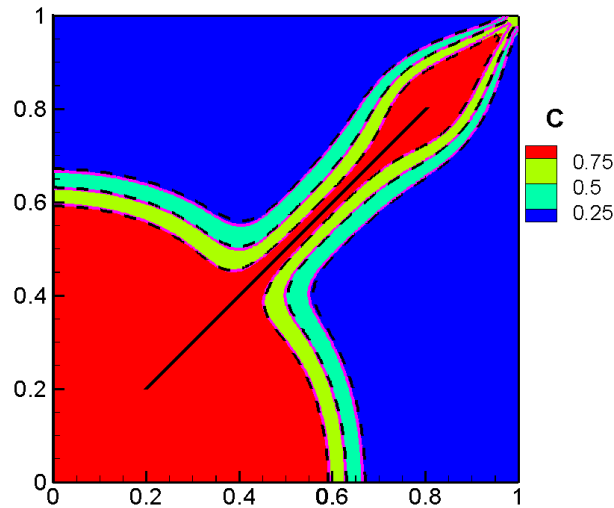

470

471 **Figure 5:** Concentration distribution for the fractured saturated quarter-five-spot problem.

472 Results of the new 1D-2D MFE model (dashed lines), the 1D-2D Comsol FE model (purple

473 lines), and 2D-2D DG model (color map).

474 The problem is simulated with the new 1D-2D MFE model as well as with the 1D-2D Comsol

475 FE model and the 2D-2D DG model of Younes *et al.* (2021). In the latter, the hydraulic and

476 transport parameters used for the fractures in the 1D-2D approach are attributed to the 2D

477 triangular elements located inside the fractures. The 2D-2D DG model is used with a fine

478 mesh with local mesh refinement around fractures. The three models were used with the MOL

479 and a variable high-order (up to 5) time integration BDF method. Figure 5 shows that the

480 three models yield almost similar concentration distributions, which demonstrates the validity

481 of the developed 1D-2D MFE model for simulating flow and transport in fractured saturated

482 porous media.

483

484 4.2 Infiltration of contaminated water in a fractured unsaturated-saturated porous medium.

485 This test case, inspired by the laboratory experiments of Vauclin *et al.*, (1979), was proposed

486 by Koohbor *et al.* (2020) to investigate unsaturated flow in fractured porous media. The

487 problem is extended hereafter to tackle both flow and transport in the case of a homogeneous

488 porous medium, including a single inclined fracture. The domain has a rectangular shape of

489 300cm×200 cm with a water table located at 65cm from the bottom. Initial conditions
 490 correspond to a hydrostatic pressure distribution and a zero concentration in the domain.
 491 Boundary conditions are as follows: contaminated water is infiltrated under a constant flux of
 492 335cm/day over the first 50cm of the soil surface. The lower 65cm of the right side of the
 493 domain has a Dirichlet boundary condition with a fixed head of 65cm. A no-flow boundary is
 494 prescribed for the rest of the boundaries. The homogeneous porous medium includes an
 495 inclined fracture of 1cm aperture and 2m length, located near the infiltration zone. The
 496 hydraulic and transport parameters are depicted in Table 2.
 497

	K_s (m/s)	S_s (1/m)	θ_s	θ_r	α (1/m)	n	α_L (m)	α_T (m)	D_m (m ² /s)
Matrix	$5 \cdot 10^{-5}$	10^{-10}	0.4	0.1	3.31	2.1	0	0	10^{-7}
Fracture	10^{-2}	10^{-10}	0.4	0.01	3.31	2.1	0	0	10^{-7}

498 **Table 2:** Hydraulic and transport parameters for the problem of infiltration of contaminated
 499 water into a fractured unsaturated-saturated porous medium.

500 The simulation of this problem cannot be performed with the 1D-2D Comsol FE model since
 501 Comsol cannot treat unsaturated flow in the fractures. The problem is simulated with the 1D-
 502 2D MFE model as well as with the 2D-2D DG model and the 2D-2D FE model of Comsol.
 503 Figure 6 depicts the water content and the concentration distributions at $t = 1000s$ obtained
 504 with the three models. A good agreement is observed between the results of the three models
 505 for the volumetric water content as well as for the concentration contours (Figure 6).

506

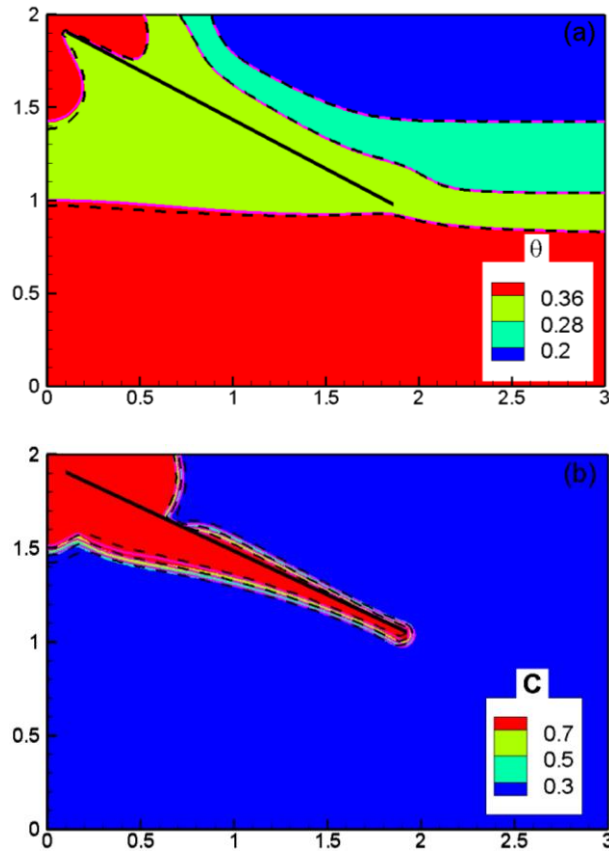

507

508 **Figure 6:** Water content (a) and concentration (b) distributions for the problem of infiltration
509 of contaminated water in a fractured unsaturated-saturated porous medium. Results of the new
510 1D-2D MFE model (dashed lines), 2D-2D DG model (purple lines), and 2D-2D FE Comsol
511 model (color map).

512

513 A more in-depth comparison is then performed between the new 1D-2D MFE model and the
514 2D-2D DG model. To this aim, the fluid and contaminant mass fluxes at the outlet are
515 calculated with both models over the simulation time of 55 hours. The results of the Figure 7
516 show that the outlet fluid flux is almost constant after around 15 hours which indicates that an
517 almost steady state water content distribution is reached at this time. A first contaminant front,
518 caused by the fast mobility of the contaminated water through the fractures, is observed in the
519 Figure 7 after around 10 hours. A second slower and more dispersed contaminant front was
520 occurred, which was caused by the transport of the contaminant through the rock matrix. The

521 results of Figure 7 show a very good agreement between the 1D-2D MFE and the 2D-2D DG
522 models for both fluid and contaminant outlet mass fluxes. These results demonstrate the
523 validity of the new 1D-2D MFE model for the simulation of flow and transport in fractured
524 unsaturated porous media.

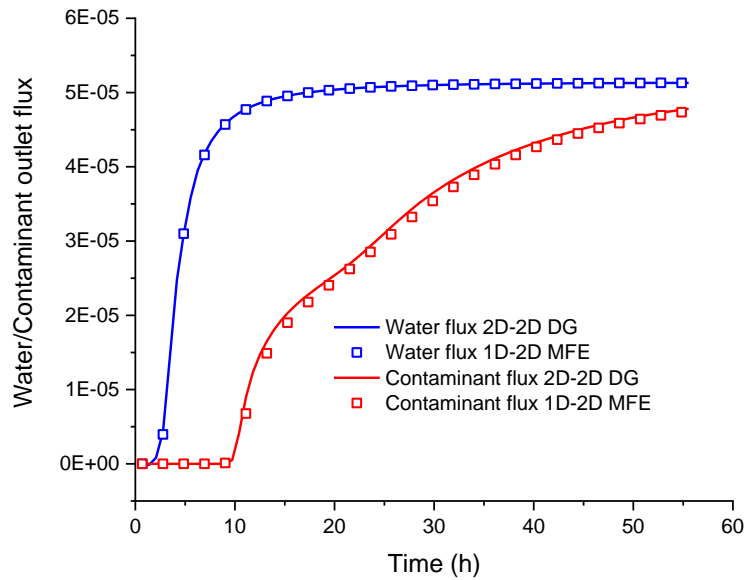

525
526 **Figure 7:** Outlet fluid and contaminant mass fluxes obtained with the 1D-2D MFE and the
527 2D-2D DG models for the problem of infiltration of contaminated water in a fractured
528 unsaturated-saturated porous medium.

530 4.3 Infiltration of contaminated water in a fractured dry soil.

531 Simulation of the infiltration of contaminated water into initially dry soils is known to be
532 challenging because of the presence of sharp wetting fronts (Zha *et al.*, 2017). Sharp fronts
533 are often the origin of unphysical oscillations, which can cause several convergence issues. To
534 investigate the efficiency of the developed model for such situations, we simulate an
535 infiltration problem, adapted from Koohbor *et al.* (2020). The fractured porous medium has a
536 rectangular shape of 350cm in length and 200cm in height (Figure 8a). Left and right vertical
537 boundaries are impermeable. A pressure head of -1000 cm is imposed at the bottom of the

538 domain. Water is injected at the right part of the surface ($300\text{cm} \leq x \leq 350\text{cm}$) with a constant
 539 flow rate of 4×10^{-4} cm/s. The simulation is performed for a period of 2×10^5 s. Clean water is
 540 injected for the first half period ($C = 0$ if $t \leq 10^5$ s), and contaminated water is injected for
 541 the second half period ($C = 1$ if $t > 10^5$ s). Initial conditions correspond to a highly dry soil
 542 with a head of -1000cm in both matrix and fracture continua. All fractures have an aperture of
 543 1cm.

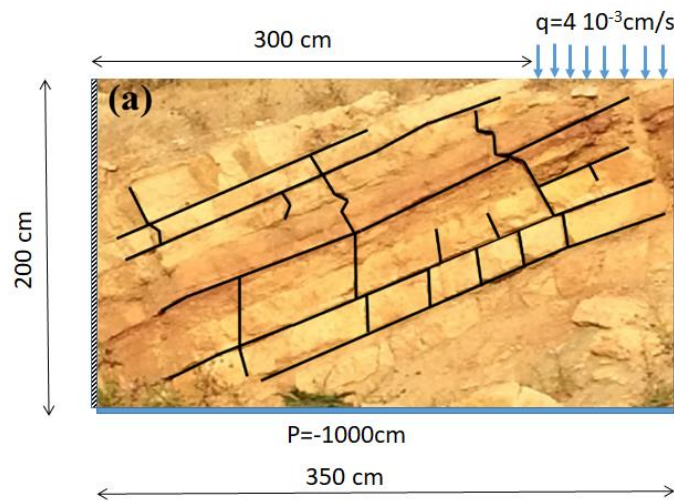

544

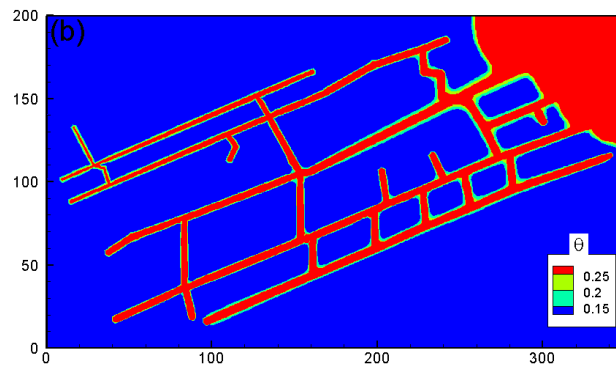

545

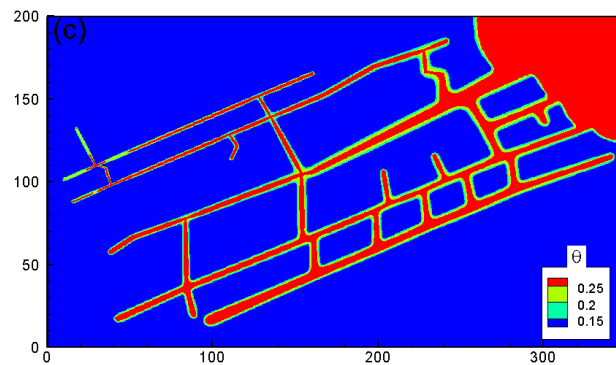

546

547 **Figure 8:** The problem of infiltration of contaminated water in a fractured initially dry soil:
 548 (a) domain and boundary conditions, (b) final water content distribution obtained with the 1D-
 549 2D MFE model and with the 2D-2D DG model (c).

550

551 The hydraulic parameters of the two continua are depicted in Table 3.

	K_s (cm/s)	S_s (1/cm)	θ_s	θ_r	α (1/cm)	n
Matrix	$5.25 \cdot 10^{-6}$	10^{-8}	0.34	0.01	0.0139	1.6
Fracture	$1.16 \cdot 10^{-2}$	10^{-8}	0.8	0.001	0.0139	1.6

552 **Table 3:** Hydraulic parameters for the problem of infiltration of contaminated water in a
 553 fracture initially dry soil.

554 The simulation of this last test case with the 2D-2D FE Comsol model encountered several
 555 convergence issues because of the initial high dry conditions. Indeed, the initial dry conditions
 556 are responsible of the appearance of several unphysical oscillations leading to the non-
 557 convergence of the nonlinear flow-transport model. These difficulties are avoided with the
 558 2D-2D DG model thanks to the incorporated advanced numerical methods (see Younes et al.
 559 (2021) for more details). As a consequence, the results of the new 1D-2D MFE model are
 560 only compared to those of the 2D-2D DG model. The final water content distribution obtained
 561 with the two models is depicted in Figure 8. Similar distributions are obtained with the two
 562 models. As expected, the infiltrated water invades the fracture network, and high water
 563 saturation is observed in almost all fracture branches (Figure 8) because of their high
 564 saturated hydraulic conductivity, which is around 2200 times higher than that of the matrix
 565 continuum. Two configurations are investigated. The first configuration corresponds to a

566 highly advective transport problem. In this case, all dispersivities of the matrix and the
567 fractures are zero ($\alpha_L^m = \alpha_T^m = \alpha_L^f = 0$), and a small molecular diffusion occurs in both
568 continua ($D_m^m = D_m^f = 10^{-6} \text{ cm}^2/\text{s}$). In the second configuration, a more significant dispersion
569 is considered for both continua with longitudinal and transverse dispersivities in the matrix,
570 respectively $\alpha_L^m = 5m$, and $\alpha_T^m = 2m$. The longitudinal dispersivity in the fractures is
571 $\alpha_L^f = 5m$. The molecular diffusion in both continua is $10^{-5} \text{ cm}^2/\text{s}$. For the 1D-2D model, the
572 domain is discretized using 15400 triangles for the matrix continuum and 853 lines for the
573 fracture branches without any constraint on the size of mesh elements next to the fractures
574 (Figure 9a). The 2D-2D model is used on a fine mesh of 76000 elements with local mesh
575 refinement in the fractures in order to correctly discretize the flow and transport through the
576 fracture branches with a small aperture of 1cm (Figure 9b).

577

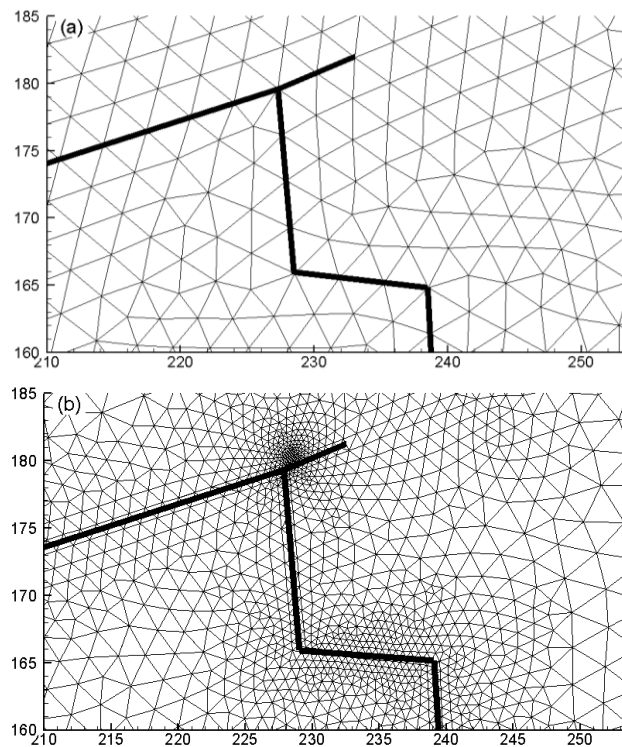

578

579 **Figure 9:** Spatial discretization for the 1D-2D MFE (a) model (fractures are represented by
580 mesh edges) and for the 2D-2D DG (b) model (fractures are represented by small mesh
581 elements).

582 Two versions of the 1D-2D MFE model are employed for the simulations: (i) the upwind
583 scheme described above and (ii) a centered scheme where no upwinding is used for the
584 advection operator in the matrix nor in the fractures. The results of Figure 10 show that the
585 centered scheme provides similar results to the upwind scheme in the case of high dispersion
586 (Figures 10d and 10e). However, in the case of advection-dominated transport, the centered
587 scheme fails to provide accurate results and generates strong unphysical concentrations both
588 in the matrix and in the fracture continuum (Figure 10b). The results of the upwind 1D-2D
589 MFE model are exempted from unphysical oscillations (negative concentration are
590 completely avoided) for both advection dominated and advection-dispersion configurations
591 which demonstrates the robustness of the developed upwind 1D-2D MFE scheme.
592 Furthermore, the solution of the upwind 1D-2D MFE model is in good agreement with the
593 solution of the 2D-2D DG model both in the case of advection-dominated transport (Figure
594 10a vs 10c) and in the case of advection-dispersion transport (Figure 10d vs. 10f).

595 The advantage of using a high-order time discretization scheme is investigated by comparison
596 against the first-order (conventional) scheme. The simulation using the upwind 1D-2D MFE
597 model with a first-order time discretization scheme requires 20902 time steps and needs
598 6566s, whereas the high-order scheme requires only 3401 time steps and needs 375s. Thus,
599 the high-order method is around four times faster than the first order method. Concerning the
600 efficiency of the 1D-2D approach in comparison to the 2D-2D approach, the 2D-2D DG
601 model required 5259s for the whole simulation, whereas the new 1D-2D MFE model requires
602 only 375s. Thus, the new 1D-2D MFE model is around 15 times more efficient than the 2D-

603 2D DG model, which highlights the great benefit of robust and accurate 1D-2D models to
604 simulate flow and transport processes in unsaturated and saturated fractured porous media.
605

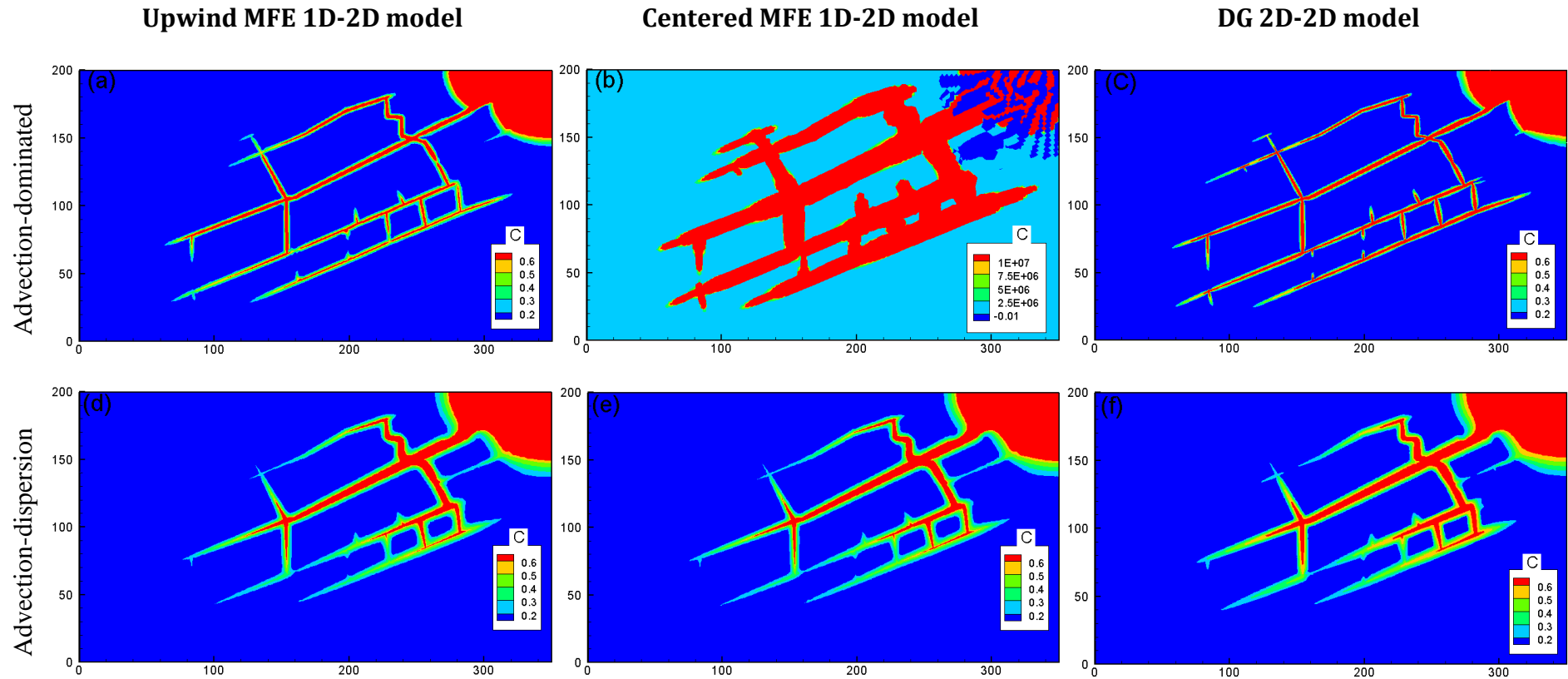

607 **Figure 10:** Infiltration of contaminated water in a fractured initially dry soil: Results of the upwind 1D-2D MFE model, the centered 1D-2D
 608 MFE model and the 2D-2D DG model in the case of advection dominated transport ($\alpha_L^m = \alpha_T^m = \alpha_L^f = 0$ and $D_m^m = D_m^f = 10^{-6} \text{ cm}^2/\text{s}$) and in the
 609 case of advection-dispersion transport ($\alpha_L^m = \alpha_L^f = 5m$, $\alpha_T^m = 2m$, and $D_m^m = D_m^f = 10^{-5} \text{ cm}^2/\text{s}$).

610

611 **5. Conclusion**

612 A new model has been developed for nonlinear flow and transport in unsaturated fractured
613 porous media with implicit matrix-fracture and fracture-fracture fluid and contaminant
614 exchanges. The model is based on the DFM approach, which describes fractures and matrix
615 explicitly. Cross-flow equilibrium is assumed only across the fractures thanks to the MFE
616 method which has been employed for the full spatial discretization of the flow and transport in
617 both the matrix and the fracture continua. The MFE method avoids the constraints on the
618 mesh size next to the fractures and allows to approximate the matrix-fracture and fracture-
619 fracture exchange without any transfer functions. An upwind scheme is employed to avoid
620 unphysical oscillations in the case of advection dominant transport. The time integration is
621 performed with variable high-order methods via the MOL. An efficient automatic time-
622 stepping scheme is used to improve the computational efficiency while maintaining accuracy
623 of the nonlinear solver.

624 Three test problems dealing with flow and mass transport in saturated and unsaturated
625 fractured porous media have been simulated to investigate the validity and robustness of the
626 new 1D-2D MFE model. The first test case deals with the fractured quarter-five-spot problem
627 and concerns flow and transport in a saturated porous medium involving a single fracture. The
628 results of this test case with the 1D-2D MFE model were similar to those of the 1D-2D FE
629 Comsol model and that of the 2D-2D DG model, which demonstrates the validity of the new
630 model to simulate flow and transport in fractured saturated porous media.

631 The second test case deals with flow and transport in an unsaturated-saturated porous
632 medium, including a single inclined fracture. This test case has been simulated with the 1D-
633 2D MFE model as well as with the 2D-2D DG model and the 2D-2D FE model of Comsol

634 since the 1D-2D FE model of Comsol cannot treat unsaturated flow in fractures. A very good
635 agreement is obtained between the three models for both the volumetric water content and the
636 concentration contours, which demonstrates the validity of the new model for unsaturated
637 fractured porous media.

638 The last test case is a challenging problem dealing with flow and transport in an initially dry
639 soil containing a fracture network. For this problem, the 2D-2D FE Comsol model
640 encountered several convergence issues because of the initial high dry soil conditions. The
641 problem has been simulated using the 1D-2D MFE model using upwind and centered
642 schemes. The results show that both schemes yield accurate results in the case of high
643 dispersion. However, in the case of advection-dominated transport, only the upwind scheme
644 provides stable results. The solution of the upwind 1D-2D MFE model is in good agreement
645 with the solution of the 2D-2D DG model both in the case of advection-dominated transport
646 and in the case of advection-dispersion transport.

647 The new 1D-2D MFE model is much more efficient than the 2D-2D DG model. The new
648 model allows a speedup of around 15, which confirms the usefulness of efficient and accurate
649 models based on the DFM approach for the simulation of flow and transport in fractured
650 porous media.

651

652

653

654

- 656 Wireman, M., 2003. EPA update: Characterization and management of ground water
657 resources in fractured-rock hydrogeologic settings. *Ground Water Monitoring &*
658 *Remediation*, 23(3), 34-40. doi:10.1111/j.1745-6592.2003.tb00681.x.
- 659 Kavouri, K.P., Karatzas, G.P., Plagnes, V., 2017. A coupled groundwater-flow-modelling and
660 vulnerability-mapping methodology for karstic terrain management. *Hydrogeol J* 25,
661 1301–1317. <https://doi.org/10.1007/s10040-017-1548-6>
- 662 Berkowitz, B. 2002. Characterizing flow and transport in fractured geological media: a
663 review. *Advances in Water Resources*, 25(8), 861–884. doi:10.1016/S0309-
664 1708(02)00042-8.
- 665 Brutz, M., and Rajaram, H., 2017. Coarse-scale particle tracking approaches for contaminant
666 transport in fractured rock. *Applied Mathematical Modelling*, 41, 549-561. doi:
667 10.1016/j.apm.2016.09.023.
- 668 Klammler, H., Hatfield, K., Newman, M. A., Cho, J., Annable, M. D., Parker, B. L., Cherry,
669 J. A., and Perminova, I., 2016. A new device for characterizing fracture networks and
670 measuring groundwater and contaminant fluxes in fractured rock aquifers. *Water*
671 *Resources Research*, 52(7), 5400-5420. doi: 10.1002/2015WR018389.
- 672 Follin, S., and Stigsson, M., 2014. A transmissivity model for deformation zones in fracture
673 crystalline rock and its possible correlation to in situ stress at the proposed high-level
674 nuclear waste repository site at Forsmark, Sweden. *Hydrogeology Journal*, 22(2), 299-
675 311. doi:10.1007/s10040-013-1078-9.
- 676 Mattila, J., and Tammisto, E., 2012. Stress-controlled fluid flow in fractures at the site of a
677 potential nuclear waste repository, Finland. *Geology*, 40(4), 299-302. doi:
678 10.1130/G32832.1.
- 679 Li, X., Zhang, D., Li, S., 2015. A multi-continuum multiple flow mechanism simulator for
680 unconventional oil and gas recovery. *Journal of Natural Gas Science and Engineering*
681 26, 652–669. <https://doi.org/10.1016/j.jngse.2015.07.005>
- 682 Shen, W., Xu, Y., Li, X., Huang, W., Gu, J., 2016. Numerical simulation of gas and water
683 flow mechanism in hydraulically fractured shale gas reservoirs. *Journal of Natural Gas*
684 *Science and Engineering* 35, 726–735. <https://doi.org/10.1016/j.jngse.2016.08.078>
- 685 Berre, I., Doster, F. & Keilegavlen, E. Flow in Fractured Porous Media: A Review of
686 Conceptual Models and Discretization Approaches. *Transp Porous Med* 130, 215–236
687 (2019). <https://doi.org/10.1007/s11242-018-1171-6>
- 688 Koohbor, B.; Fahs, M.; Hoteit, H.; Doummar, J.; Younes, A.; Belfort, B. An Advanced
689 Discrete Fracture Model for Variably Saturated Flow in Fractured Porous Media. *Adv.*
690 *Water Resour.* 2020, 140, 103602
- 691 Durlofsky, L.: Numerical calculation of equivalent grid block permeability tensors for
692 heterogenous porous media. *Water Resour. Res.* 27(5), 699–708 (1991)
- 693 Liu, R., Li, B., Jiang, Y., Huang, N.: Review:Mathematical expressions for estimating
694 equivalent permeability of rock fracture networks. *Hydrogeol. J.* 24(7), 1623–1649
695 (2016)
- 696 Jourde, H., Cornaton, F., Pistre, S., Bidaux, P., 2002. Flow behavior in a dual fracture
697 network. *Journal of Hydrology* 266, 99–119. [https://doi.org/10.1016/S0022-
698 1694\(02\)00120-8](https://doi.org/10.1016/S0022-1694(02)00120-8)
- 699 Kordilla, J., Sauter, M., Reimann, T., Geyer, T., 2012. Simulation of saturated and
700 unsaturated flow in karst systems at catchment scale using a double continuum
701 approach. *Hydrol. Earth Syst. Sci.* 16, 3909–3923. [https://doi.org/10.5194/hess-16-
702 3909-2012](https://doi.org/10.5194/hess-16-3909-2012)
- 703 Kuhlman, K.L., Malama, B., Heath, J.E., 2015. Multiporosity flow in fractured low-

704 permeability rocks. *Water Resources Research* 51, 848–860.
705 <https://doi.org/10.1002/2014WR016502>

706 Wu, Y.-S., Liu, H.H., Bodvarsson, G.S., 2004. A triple-continuum approach for modeling
707 flow and transport processes in fractured rock. *Journal of Contaminant Hydrology* 73,
708 145–179. <https://doi.org/10.1016/j.jconhyd.2004.01.002>

709 Noorishad, J., and M. Mehran (1982), An upstream finite element method for solution of
710 transient transport equation in fractured porous media, *Water Resour. Res.*, 18(3), 588 –
711 596.

712 Baca, R., R. Arnett, and D. Langford (1984), Modeling fluid flow in fractured porous rock
713 masses by finite element techniques, *Int. J. Numer. Methods Fluids*, 4, 337 – 348.

714 Granet S, Fabrie P, Lemmonier P, Quitard M. A single phase flow simulation of fractured
715 reservoir using a discrete representation of fractures. In: *Proceedings of the 6th*
716 *European conference on the mathematics of oil recovery (ECMOR VI)*, September 8–
717 11, Peebles, Scotland, UK; 1998.

718 Hoteit H., Firoozabadi A. (2008) An efficient numerical model for incompressible two-phase
719 flow in fractured media, *Adv. Water Resour.* 31, 891–905.

720 Flemisch B, Inga Berre, Wietse Boon, Alessio Fumagalli, Nicolas Schwenck, Anna Scotti,
721 Ivar Stefansson, Alexandru Tatomir, Benchmarks for single-phase flow in fractured
722 porous media, *Advances in Water Resources*, Volume 111, 2018, Pages 239-258, ISSN
723 0309-1708, <https://doi.org/10.1016/j.advwatres.2017.10.036>.

724 Martin, V., Jaffré, J., Roberts, J.E., 2005. Modeling fractures and barriers as interfaces for
725 flow in porous media. *SIAM J. Sci. Comput.* 26 (5), 1667–1691.

726 Hoteit H, Firoozabadi A. Multicomponent fluid flow by discontinuous Galerkin and mixed
727 methods in unfractured and fractured media. *Water Resour Res* 2005;41(11):W11412.

728 Hoteit H, Firoozabadi A. Compositional modeling of discrete-fractured media without
729 transfer functions by the discontinuous Galerkin and mixed methods. *SPE J*
730 2006;11(3):341–52.

731 Raviart PA, Thomas JM. A mixed finite element method for second order elliptic problems, in
732 *Mathematical Aspects of Finite Element Method*, Lecture Notes in Mathematics, 1977;
733 Vol. 606, Springer, New York, 292-315.

734 Chavent G, J. Jaffré (1986), *Mathematical models and finite elements for reservoir*
735 *simulation*, North-Holland, Amsterdam.

736 Younes, A., Ackerer, P., Delay, F. 2010. Mixed finite element for solving 2D diffusion-type
737 equations. *Reviews of Geophysics*, 48(1).

738 Durlofsky, L. (1994), Accuracy of mixed and control volume finite element approximations to
739 darcy velocity and related quantities, *Water Resour. Res.*, 30(4), 965 – 974.

740 Younes, A., Ackerer, P., Lehmann, F., 2006. A new mass lumping scheme for the mixed
741 hybrid finite element method. *International Journal for Numerical Methods in*
742 *Engineering* 67(1), 89-107.

743 Belfort, B., Ramasomanan, F., Younes, A., Lehmann, F., 2009. An efficient Lumped Mixed
744 Hybrid Finite Element Formulation for variably saturated groundwater flow. *Vadose*
745 *Zone Journal*. 8, 352-362.

746 Fahs, M., Younes, A., Lehmann, F., 2009. An easy and efficient combination of the Mixed
747 Finite Element Method and the Method of Lines for the resolution of Richards’
748 Equation. *Environmental Modelling & Software* 24(9), 1122-1126.

749 Younes, A., Fahs, M., Ahmed, S., 2009. Solving density driven flow problems with efficient
750 spatial discretizations and higher-order time integration methods. *Advances in Water*
751 *Resources* 32(3), 340-352.

- 752 Fahs, M., Younes, A., Lehmann, F., 2009. An easy and efficient combination of the Mixed
753 Finite Element Method and the Method of Lines for the resolution of Richards'
754 Equation. *Environmental Modelling & Software* 24(9), 1122-1126.
- 755 van Genuchten, M.Th., 1980. A Closed-form Equation for Predicting the Hydraulic
756 Conductivity of Unsaturated Soils. *Soil Science Society of America Journal* 44(5), 892-
757 898.
- 758 Mualem, Y., 1976. A new model for predicting the hydraulic conductivity of unsaturated
759 porous media. *Water Resources Research* 12, 513–522.
- 760 Younes, A., Ackerer, P., Chavent, G., 2004. From mixed finite elements to finite volumes for
761 elliptic PDE in 2 and 3 dimensions. *International Journal for Numerical Methods in*
762 *Engineering*, 59, 365–388.
- 763 Farthing, M.W., Kees, C.E., Miller, C.T., 2002. Mixed finite element methods and higher-
764 order temporal approximations. *Advances in Water Resources* 25, 85-101.
- 765 Tocci, M.D., Kelly, C.T., Miller, C.T., 1997. Accurate and economical solution of the
766 pressure-head form of Richards' equation by the method of lines. *Advances in Water*
767 *Resources* 20, 1–14.
- 768 Kavetski, D., Binning, P., Sloan, S.W., 2001. Adaptive backward Euler time stepping with
769 truncation error control for numerical modelling of unsaturated fluid flow. *International*
770 *Journal for Numerical Methods in Engineering* 53,1301–1322.
- 771 Kees, C.E., Miller, C.T., 2002. Higher order time integration methods for two-phase flow.
772 *Advances in Water Resources* 25(2), 159-177.
- 773 Hindmarsh, A.C., 1982. Large ordinary differential equation systems and software. *IEEE*
774 *Control System Magazine* 2, 24-30.
- 775 Younes, A., Koohbor, B., Belfort, B., Ackerer, P., Doummar, J., Fahs, M., 2021. Modeling
776 variable-density flow in saturated-unsaturated porous media: An advanced numerical
777 model. *Advances in Water Resources*, Volume 159, January 2022, 104077.
778 10.1016/j.advwatres.2021.104077
- 779 Vauclin, M., Khanji, D., Vachaud, G., 1979. Experimental and numerical study of a transient,
780 two-dimensional unsaturated-saturated water table recharge problem. *Water Resour.*
781 *Res.* 15, 1089–1101. <https://doi.org/10.1029/WR015i005p01089>
- 782 Zha, Y., Yang, J., Yin, L., Zhang, Y., Zeng, W., Shi, L., 2017. A modified Picard iteration
783 scheme for overcoming numerical difficulties of simulating infiltration into dry soil.
784 *Journal of Hydrology* 551, 56–69.
- 785