



**HAL**  
open science

## Machine learning-based models for supporting optimal exploitation of process Off-gases in integrated steelworks

Ismael Matino, Stefano Dettori, Angelo Castellano, Ruben Matino, Claudio Mocci, Marco Vannocci, Alessandro Maddaloni, Valentina Colla, Andreas Wolff

### ► To cite this version:

Ismael Matino, Stefano Dettori, Angelo Castellano, Ruben Matino, Claudio Mocci, et al.. Machine learning-based models for supporting optimal exploitation of process Off-gases in integrated steelworks. Cybersecurity workshop by European Steel Technology Platform (ESTEP), Oct 2020, Pisa (IT), Italy. pp.104-118, 10.1007/978-3-030-69367-1\_9 . hal-04297075

**HAL Id: hal-04297075**

**<https://hal.science/hal-04297075>**



Submitted on 24 Nov 2023

**HAL** is a multi-disciplinary open access archive for the deposit and dissemination of scientific research documents, whether they are published or not. The documents may come from teaching and research institutions in France or abroad, or from public or private research centers.

L'archive ouverte pluridisciplinaire **HAL**, est destinée au dépôt et à la diffusion de documents scientifiques de niveau recherche, publiés ou non, émanant des établissements d'enseignement et de recherche français ou étrangers, des laboratoires publics ou privés.



# Machine Learning-Based Models for Supporting Optimal Exploitation of Process Off-Gases in Integrated Steelworks

Ismael Matino<sup>1</sup>(✉) , Stefano Dettori<sup>1</sup> , Angelo Castellano<sup>1</sup>,  
Ruben Matino<sup>1</sup>, Claudio Mocci<sup>1</sup>, Marco Vannocci<sup>1</sup>,  
Alessandro Maddaloni<sup>1</sup>, Valentina Colla<sup>1</sup> , and Andreas Wolff<sup>2</sup>

<sup>1</sup> Scuola Superiore Sant'Anna, TeCIP Institute, ICT-COISP Center, Pisa, Italy  
{i.matino, s.dettori, a.castellano, r.matino, c.mocci,  
m.vannocci, a.maddaloni, v.colla}@santannapisa.it

<sup>2</sup> Betriebsforschungsinstitut, Sohnstrasse 65, 40237 Düsseldorf, Germany  
andreas.wolff@bf.de

**Abstract.** Within integrated steelworks, several sub-processes produce off-gases, which are suitable for reuse as energy sources for other internal processes as well as for the production of energy. An adequate and optimal distribution of these gases among their users allows valorizing at best their energy content by minimizing the need to both burn them through torches due to storage issues and to acquire natural gas to satisfy the internal energetic demand. To this purpose, the volume and energetic value of produced gases as well as the demands from internal users must be known in advance, in order to implement model-predictive control strategies aimed at satisfying the demands on the short-medium term based on the production scheduling. Such forecasting knowledge also enhances the capability to react to the variability of the process scheduling as well as to other unforeseen events.

The paper depicts an application of Machine Learning-based models to forecast off-gases and further energy carriers productions and demands within integrated steelworks. The forecasting models are integrated into a complex hierarchical control strategy aimed at optimizing the distribution of such gases.

**Keywords:** Decision support system · Echo state neural network · Model predictive control · Process off-gas management · Steelworks sustainability

## 1 Introduction

Steel has always been and will continue to be a fundamental material for the society thanks to its characteristics of durability, versatility and recyclability. It plays a central role for the society development as well as for its evolution toward an environmental friendly community. To keep such role, the European steel sector attributes a fundamental importance to resource and energy efficiency and to reduction of carbon footprint and emissions related to its production processes. The European steel production represents about 16% of worldwide production and 8.5% belongs to the European Union (EU) countries [1]. Considering these figures, improving the environmental and

economic sustainability of the steel sector can help increase the competitiveness of European industry and improving the European economy as a whole. This is considered fundamental by the EU that through the *European Green Deal* will “support industry to innovate and to become global leaders in the green economy” [2].

In this context, integrated steelworks are focusing their efforts toward reduction of emissions as well as energy and resource consumptions. The integrated steelmaking route actually exploits a high amount of resources and generates important volumes of by-products, wastes and emissions. In addition, about 25% of production costs are related to energy [3]. Often resource and energy management are linked together and an improvement of resource management can lead to an optimization of energy management and vice versa. Process Off-Gases (POGs) are exemplar in this sense, as they are a by-product but also a resource, being a significant energy carrier.

POGs are produced in main production steps of the integrated route: Coke Oven Gas (COG) derives from coke production, Blast Furnace Gas (BFG) is produced together with pig iron and Basic Oxygen Furnace Gas (BOFG) is generated during pig iron conversion into steel. These gases are rich in CO and H<sub>2</sub>, have a significant Net Calorific Value (NCV) and, therefore, are generally recovered and exploited as internal energy source or for electricity production. Nevertheless, their management and distribution are often not optimized due to the complexity of the integrated route that combines different steps and several units, of the related gas/steam/electricity networks and also of the involved production plans. Gas over-production and under-production are common issues which lead, respectively, to storage issues (i.e. full gasholder is often translated in flared gas or slowdown of the production) or to dissatisfaction of gas demand with consequent exploitation of natural gas.

Different solutions can be implemented to improve the use of these valuable resources avoiding their waste or their lack. Some solutions are related to Carbon Capture and Usage and Storage (CCUS) or other chemical conversion-related solutions. For instance, the *Steelanol* project aims at converting the CO and H<sub>2</sub> contained in the BFG into ethanol by using fermentation by microbes [4]. The *Carbon2Chem* project promotes the use of steelmaking top gases for the production of basic chemicals, plastics and synthetic fuels [5, 6]. The ongoing *i3upgrade* project focuses on the production of methane and methanol by exploiting steelworks gases after enrichment with green hydrogen and by coupling innovative processes and an advanced dispatch controller [7]. The use of steelworks gases for methanol production is also investigated in other literature studies [8–11]: different synthesis processes are investigated and techno-economic analyses are carried out. The *VALORCO* project investigates the capture of carbon dioxide of BFG through amine scrubbing technologies [12].

On the other hand, different investigations and studies focuses on improving the management of process off-gases and maximizing their internal use. To this aim, forecasting models have also been developed to support optimization approaches. For instance, Neural Networks (NN)-based models forecasting the production of BFG were developed by Zhang et al. [13] and by Yang et al. [14], who exploits genetic algorithm and least-squares support-vector machine. Zhao et al. [15, 16] uses the novel Echo State NNs (ESN) for both BFG and COG production. ESNs are also used in [17] to forecast steam production and consumption within steelworks. Porzio et al. developed an offline Decision Support System (DSS) including modules for static simulation and

optimization allowing the monitoring and the reduction of CO<sub>2</sub> emissions from wasted off-gases by providing offline optimal solutions of gases distribution [18–20]. Different multi objective optimization approaches were investigated and compared for optimal distribution of off-gases [20]; among others, interesting are Genetic Algorithm [21], Mixed Integer Linear Programming (MILP) [22, 23] and multi-period optimization [24]. However, all of these works present some issues that can be listed as follows: the gas networks (one for each gas), the steam network and all involved processes, phenomena and related operating conditions and constraints are not considered as a whole and the different synergetic aspects are neglected; not all the energy carriers are considered jointly; the volume and energy amount of the different energy carries are sometimes decoupled; production plan is not considered in the forecasting and optimization purposes; if global optimization is carried out, it is made in offline mode. Thus, starting from the high valuable works found in literature and by considering their bottlenecks, a DSS has been developed during a cutting-edge project, namely *GASNET*. The DSS aims to fill the previous listed gaps and to obtain a holistic and online optimization of the integrated steelworks off-gas management by coupling in its core a forecasting model library and an advanced online optimization tool. In particular, the model library includes, among others, Machine Learning (ML)-based models that allow the prediction of production and demand of amount and energy content of main energy carriers (i.e. off-gases, steam and electricity). On the other hand, a Hierarchical Control and Supervision system based on Economic Model Prediction Control (EMPC) methodologies is applied for the optimization of POGs distribution and energy flows.

The work presented in the paper improves the current state of the art concerning off-gas management in the steel field by introducing the consideration of the whole production plant, through an approach involving a sort of “digital twin” of the entire steelworks from the point of view of energy production, exploitation and transformation. This digital twin, based on different ML methodologies, has been integrated into an advanced control system, which also improves the current state of the art for the optimization of energy flows within integrated steelworks.

The paper is organized as follows: Sect. 2 summarizes the aims of the *GASNET* project and introduces the developed software. Section 3 describes the adopted modelling approaches and optimization strategies. Section 4 overviews the most representative models. Section 5 discusses the simulation and optimization results. Finally, the Sect. 6 provides some concluding remarks.

## 2 Overview of the *GASNET* Project and Software

*GASNET* is a project funded by the Research Fund for Coal and Steel, which aimed at upgrading the actual management of off-gases coming from the steelmaking processes by optimizing the distribution and use of these gases. This was obtained thanks to the holistic view of all involved “actors” and related constraints in the energy management. The main outcome is an integrated simulation and decision support tool, which is articulated in 2 modules that can be installed and run independently or can be jointly used:

1. An online module that allows continuous monitoring and optimization of energy carriers networks, which is in turn composed of the following sub-modules: industrial plant and energy database, forecasting model library, online control and optimization tool, Key Performance Indicator (KPIs) calculator.
2. An offline network optimizer which allows also making structural modifications (e.g. dismantling or building new pipes) [25].

Both modules have an easy-to-use Graphical User Interface (GUI) that allows the exploitation of the different software areas (e.g. model configuration, model use, optimization configuration) and the visualization of the main results. Some screenshots of the GUI of the two modules are depicted in Fig. 1.



**Fig. 1.** GUI of the GASNET software: a. online module; b. offline network optimizer.

### 3 Materials and Methods

Forecasting energy carriers production and demand is fundamental to implement control and optimization strategies to satisfy the demands on the short-medium terms by considering the production scheduling. A correct selection of modelling and optimization approaches is fundamental to reach the goal. Acquisition of process know-how through a strict cooperation with plant staff and literature analysis were the starting point. The selected methodologies are discussed in the following sub-paragraphs.

#### 3.1 Modelling Methodologies

The aim of forecasting models is to virtually reproduce the dynamic of the different processes, phenomena and unit operations involved in the production and use of the energy carriers in the integrated steelworks and to continuously forecast their behavior in a time horizon of 2 h, which is considered sufficient for short-term optimization purposes.

A first distinction needs to be done between producers and users. Some processes depend on their own evolution through time, while other ones are strictly correlated to

production plan or process data or their behavior is difficult to predict due a strong link with human decision-making. Most of the processes present complex dynamics and non-linear behavior. Therefore, a unique general-purpose modelling methodology is not suitable to fit all the considered process/phenomena. Moreover, a correct selection of the inputs is fundamental, taking into account staff experience, process knowledge, availability of continuous monitored and registered data. Therefore, inputs and modelling approaches have been accurately and carefully selected on a case-by-case basis exploiting literature and preliminary tests. Regarding the inputs selection, after a collection of high amount of available data from historical databases of monitored variables, detection and removal of outliers was first carried out [26–28]. Then feature space reduction was done in two stages for the datasets related to the different process/phenomena to be modelled: detection and elimination of redundant variables and selection of variables, which mostly affect the considered target [26, 29, 30].

On the other hand, concerning the modelling techniques, literature and authors previous experience suggested advantages and drawbacks of different methods physical and chemical based or data-driven. However, a preliminary testing phase was carried out to verify the applicability of different modelling approaches, their accuracy, computational burden and response for each process/phenomena to be represented. In other words, firstly the possibility to apply physical/chemical based approaches was assessed. However, in many cases, the lack of relevant information prevented both accurate development of dynamic models and systematic validation considering different status of the modelled process. In addition, the computational burden and time required by this kind of models was not suitable for continuous/real-time simulation and optimization purposes due to the high number of inputs/outputs and, in some cases, of complex iterations. Afterwards, the exploitation of a mixed approach was attempted according to the authors' previous works [18]. Such approach combines flowsheeting and ML/interpolation approaches. Stationary flowsheeting models were developed, tuned and validated by mixing real and literature data and by using well-known commercial simulation software and allow reproducing the physical/chemical phenomena of a process in different scenarios. These models are generally solved following a sequential modular approach and the flowsheet needs to converge at every iteration, because it computes every unit operation in sequence by leading to unsuitable times for the optimization task. However, they can be used as generators of data to be fed to dedicated NNs for approximate the flowsheeting simulations [31] and obtaining NN-based models with negligible computational time. This approach showed good results but it has two main issues: the propagation of errors and the difficulty to reproduce the dynamic of the systems (this feature can be neglected for off-line optimization but not for the real-time one) especially in case of complex dynamic processes, as a stationary model is used to train the NNs. Thus, it was decided to check different “native” black box techniques, especially for complex processes in order to exploit their potential in terms of capturing dynamic features, using lower numbers of inputs and requiring lower computational burden and time. After some tests, only for simpler processes equation-based models were used, but most of the models are based on ML approaches. In particular, for less state-dependent dynamics, Feed Forward NNs (FFNN) were used, with a multi-layer perceptron topology; while, for complex non-linear time dependencies, the potential of ESN was exploited. ESN represents a novel,

powerful and effective method to model complex nonlinear time dependencies [15, 16, 32–36]. In this work, they were used both in its shallow and deep architecture: they differ from the number of “dynamic” layers, namely “reservoirs”; in particular shallow ESN is provided of a single reservoir, while Deep ESN (DESN) is provided of different reservoirs in series [37, 38]. The reservoir is the nucleus of ESN, as it generates a rich set of dynamics that are combined to make regression on a target by means of supervised algorithms and thus to reconstruct complex dynamical relationship between inputs and outputs. The particular features of the dynamic reservoir provide it with an auto-feedback nature that is translated in a short-term memory of past dynamic states. Another advantage of ESNs lies in the fact that, although they are recurrent NNs, they do not exploit iterative routines and thus they have a low computational training cost.

For each ML-based model, the global dataset of real industrial data, corresponding to several months of production, were divided in two sets: 60÷70% of the data were used for training, the other ones for validation. The architecture setup of the models was optimized through a proper selection of the hyper-parameters of the specific adopted topology. In particular, for the ESN-based approach the total number of neuron, the number of layers, spectral radius, input scaling and Tikhonov regularization parameter were considered. The FFNNs architecture was optimized in terms of number of layers and total number of neurons. The mentioned hyper-parameters were optimized through a random search algorithm aimed at increasing the model accuracy, tested through the Normalized Root Mean Square Error (NRMSE):

$$NRMSE = \frac{\sqrt{\frac{1}{S} \sum_{i=1}^S (Fo_i - o_i)^2}}{M - m} \cdot 100 \quad (1)$$

where  $S$  is the data number,  $Fo_i$  and  $o_i$  are, respectively, the  $i$ -th sample of the forecasted output and real target,  $M$  and  $m$  are maximum and minimum real target values.

### 3.2 Optimization Strategies

After data preparation through synchronization of different datasets, deletion of duplicates, outlier detection and elimination through the techniques, which are described in the previous Section, the analysis of the collected data related to the plant management, POGs and steam networks structure can reveal several issues. The different behaviors of energy production, transformation and transfer (in terms of different involved energy carriers) and the production plan are considered and compared. Firstly, the overall plant production scheduling is usually not optimized. This involves energy flows that highlight large differences between the peaks of energy production and transformation and its consumption. This imbalance must be managed, firstly, through gasholders (GH) acting as buffers and allowing a margin of safety and controllability of the system, secondly by an intelligent scheduling of electricity production in internal power plants, the main POG consumers. The second evident bottleneck is the size of the GHs, whose dimensions guarantee a buffer of 30–90 min. Optimizing the use of POGs means acting in the short term, with a 2-h prediction horizon to ensure a sufficient controllability margin.

An optimal scheduling of energy flows is important to provide general indications to plant managers and process operators for improving the production scheduling. In this case, the supervision and control strategy must give indications in the medium and long term. Therefore, the supervision and control system must be structured in a hierarchical manner, according to the time horizon in which the plant energy flows can be optimized. The core of the developed DSS is based on a two-level hierarchical optimization system shown in Fig. 2.

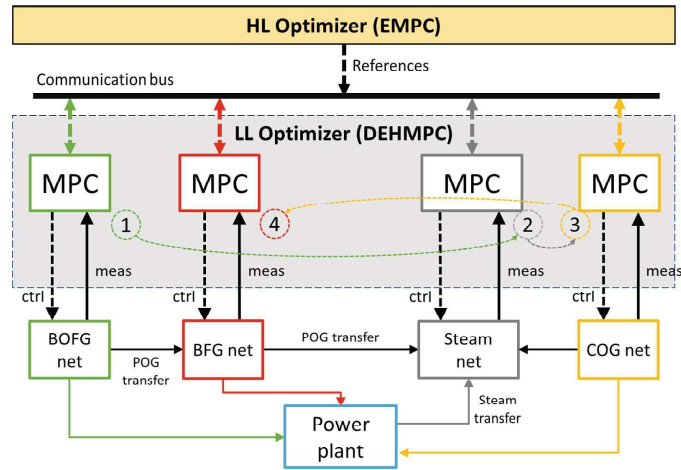

Fig. 2. Structure of the Supervision and control system.

The first level (*HL Optimizer*) optimizes the energy flow in the medium and long term, with a prediction interval between 1 day and 1 week, which allows formulating a set of possible control actions that mainly aim at scheduling the POG use in the power plant. The control action output by the *HL Optimizer* is used by the *LL Optimizer* that allows distributing the energy flows in the short term, with a higher control frequency.

The *HL Optimizer* implements a Linear Programming formulation within a control strategy based on the Economic Model Predictive Control (EMPC). The control action is computed every 15 min by minimizing the management cost in terms of consumption of Natural Gas (NG) and purchased electricity and the environmental costs related to the disposal of excess POG through torches. The optimization takes into account the main limits of the POG, steam and electricity networks, in terms of minimum and maximum operating points (e.g. gasholder levels, produced energy in the power plant, etc.).

The *LL optimizer* aims at distributing the energy flows over a prediction and control horizon of 2 h, with a control frequency of 1 min. This allows managing the dynamics of the systems involved and, above all, considering the real operating limits of each equipment. More in detail, the *LL optimizer* is structured as a distributed controller that implements several Local Economic Hybrid Model Predictive Controllers (LEHMPC), by solving in real-time a MILP formulation for each specific network [39]. Each energy



carrier network (BOFG, BFG, COG and steam) is sequentially optimized. In particular, Fig. 2 shows a possible numerated sequence of the scheduling of each network MPC and their mutual and sequential communication through the bus. The communication with the DSS (and its modules) is carried out through an interface layer between the DSS and the IT system of the plant established with ProDISS, a databank-based communication interface, which exchanges messages with different systems (e.g. plants). The communication procedure is based on different steps: the ProDISS-DSS interface receives a message from a plant with required data and stores them in an input layer in the database (DB). The communication interface starts with a PL/SQL package, which, after reading the data from the input layer, provides them in the structure required by the DSS. The data are stored in another separate layer and the DSS reads them. In this way, the whole application can run on several machines.

The supervision and control system exploits the presented model library as disturbance predictor and includes an additional set of linear models describing the dynamics of the controlled system with high accuracy, such as steam boilers, steam accumulators, GHs, power plant and turbines. The system has been prototyped in Matlab environment through YALMIP Toolbox and translated in C++ through the optimization libraries of the Google OR Tools. The DSS does not implement a closed loop control strategy, but provide advices to all the operators of the steam, POGs and power plant networks. These actions, if effectively implemented, allow optimizing the economic and environmental balance of the management of energy flows within the whole plant.

## 4 Description of Developed Model Library

The library includes models forecasting off-gases, steam and electricity production and demand by main users. The most representative ML-based ones are here described.

### 4.1 Off-Gases Production Models

Some of the most important models are related to the production of BFG and BOFG. COG is not predicted, as there are no coke ovens in the considered steelworks. The two models have a common structure; in particular, 3 specialized shallow ESNs are used for predicting respectively gas volume flow, CO and H<sub>2</sub> contents [26, 40–42]. The use of single ESNs for single output is justified by a better accuracy and lower computational cost. The sampling time and prediction frequency is of 5 min for BFG and 1 min for BOFG, as the converter process has a faster dynamic with respect to the BF. The predicted CO and H<sub>2</sub> contents are combined, after some post-processing steps, to obtain the gas NCV, which is combined to the gas volume flow to compute the heating power. For BOFG the model is split in 3 parts: the first one computes the recoverable BOFG, the second one the flareable part of BOFG, the last one the global amount of gas and related energy content. The inputs for the BFG prediction model are the current values of humidity in natural wind, oxygen content in cold wind, cold blast volume flow, pressure of mix wind, steam mass flow in cold blast wind and of amount and main composition of produced BFG. The current values of position of movable skirt, blowed

oxygen volume flow and of amount and main composition of produced BOFG are used for the BOFG model together with the values for the 2 h ahead of charged liquid pig iron, charged lime and recycled briquetted sinter. The plant scheduling for the 2 h ahead is a further input in both models in the form of a simple Boolean representation.

#### 4.2 Model of BOF Steam Production

One way to recover the heat of produced off-gases is its transformation in steam. This is the case of steam production during converter operation by exploiting the heat of BOFG. Due to its importance in energy management, a model was developed with a time resolution of 1 min and using a deep layered version of ESN because of the higher accuracy and faster training stage obtained in this situation [26, 43]. The inputs sent to the DESN are the current values of position of movable skirt, blowed oxygen volume flow, recovered BOFG and of the  $i$ -th converter steam production. Also in this case the Boolean representation of BOF scheduling for the two hours ahead is an input.

#### 4.3 Model of Electrical Power Production by BFG Expansion Turbine

Another way to transform energy between carriers is the expansion of gas to produce electrical power. For instance, BFG after its production is expanded in a dedicated turbine. A model was developed for the prediction of produced electricity [43]. Such model is in cascade to the ones related to the forecasting of BFG amount (see Sect. 4.1). The nonlinear model of the turbine efficiency is realized through a FFNN with a forecasting time frequency of 15 min.

#### 4.4 Model for BFG Demand by Hot Blast Stoves

Hot Blast Stoves (HBS) are important BFG users and are exploited to preheat the air blown into the BF. Two main alternate phases characterize their operation: the heating phase and the wind phase. During the first one, the gas combustion is carried out to heat the walls of the HBSs; this heat is then released to the cold wind during the wind phase. The demand in terms of amount of BFG is forecasted by using an ESN-based model with a time resolution of 5 min [40, 41, 44]. It is fed by the current values of cold blast volume flow, temperature of mix wind and of BFG consumption by each HBS; in addition, Boolean representation of BF plant scheduling and of HBSs operational modes for the 2 h ahead are included in the inputs.

#### 4.5 Model for Steam Injection in BF Cold Blast Wind

One of the use of steam is the injection in BF cold blast wind. A model was developed to forecast this demand, which is based on a standard ESN and is in cascade to the one forecasting the CO and H<sub>2</sub> contents in BFG (see Sect. 4.1), as their values for two hours ahead are some of the inputs. Other inputs are the current values of humidity in natural wind, steam mass flow in cold blast wind, mass flow of pulverized coal, pressure and temperatures of mix wind; a further input is the BF scheduling for 2 h ahead.

#### 4.6 Model for Electricity Demand by BF Fans

BF fans are intensive consumers of electric energy. Thus a model was developed in order to forecast the demand of electrical power by them with a frequency of 15 min. Moreover, this model uses the predicted BFG amount by related model (see Sect. 4.1). Further inputs are the current values of cold blast volume flow, the pressure of mix wind and of the total electrical power supplied to the fans; a further input is the BF scheduling for 2 h ahead.

#### 4.7 Model for Energy Demands by RH Vacuum Degassing

The Ruhrstahl Heraeus Vacuum Degassing (RHVD) process consumes steam and electricity; a simple model for the prediction of these demands was developed by feeding a shallow ESN only with the current values of consumptions and with the Boolean Representation of the scheduling of the plant [43].

### 5 Results and Discussion

#### 5.1 Prediction of Gas Production and Demand

The obtained accuracy from the models related to the prediction of offgas production and demand are considered suitable for optimization purposes. In particular, the obtained values of the NRMSE are lower than 10% for BFG and lower than 15% for BOFG considering each predicted variable (also intermediate ones), for all forecasting horizon and considering all the possible situations: start-up, stationary and shut down operations. Also in the case of HBSs, the model is capable to follow the process variations and shows a good accuracy with a NRMSE value lower than 12%. Obviously, in all the cases, the NRMSE values increases along the time horizon.

#### 5.2 Prediction of Steam and Electricity Production and Demand

The prediction of production and demand of further energy carriers gives satisfactory results in most of the cases (see Table 1.).

**Table 1.** NRMSE related to the prediction carried out with the models devoted to steam and electricity production and demand

Model	NRMSE	Note
BOF steam production	3% ÷ 6%	
Electrical power production by BFG expansion turbine	≈0.4%	
Steam injection in BF cold blast wind	<20%	For the prediction until 40 min ahead
Electricity demand by BF fans	<5%	
Steam and electricity demands by RHVD	6% ÷ 8% 5% ÷ 6%	for steam for electricity

Noticeably the model for steam injection in BF cold blast wind shows an accuracy that highly decrease in the prediction time horizon; it is suitable only for the forecasting of 40 min ahead. This can be due either to the fact that the selected inputs are not fully suitable to capture the dynamic of the process or to the predominant role of the operator in decision-making. A refining of the model or of existing procedures are thus required.

### 5.3 Optimization Results

The hierarchical supervision and control system has been tested through data of a real integrated steelworks. The tests aimed at evaluating the maximum gain which can be obtained through the DSS, thus the supervision and control system was simulated in closed loop, through the implementation of models of the controlled systems, which are characterized by high accuracy. The resulted closed loop system simulation starts from the actual state condition of each plant and exploits data of the real production plan. The results related to two different production period are here reported, showing the performances of the DSS in terms of overall costs sustained for NG and electricity purchase and of amount of gas flared through the torches in comparison to the real case. The first example is related to a period of quite constant production in terms of pig-iron, liquid steel and of refined products, while the second is related to a period of quite constant production of pig-iron and liquid steel but a non-constant production of refined products, namely energy intensive processes were not scheduled. The mentioned processes exploit large amounts of POGs and when they are not scheduled usually the excess gas is flared in the torches.

The results of each period are shown in Fig. 3 and Fig. 4. In particular, Fig. 3.a shows the daily balance of costs related to the controllable external energy sources (NG and electricity) in the top diagram, and the total costs for the overall period (bottom diagram). Figure 3.b shows the energy of the POGs burned in the torches due to their excess in the daily case (top diagram) and the overall POG wasted (bottom diagram).

Figure 4.a and Fig. 4.b show the same indicators related to the second control example. The term *CTRL* is referred to the simulated controlled behavior, while *Real* is related to the actual non-optimized management. All the results are normalized due to confidentiality constraints, with respect to the maximum value of the specific index.

The results of the application of optimization strategy show very encouraging margin of improvement of the POGs network management and in general of the energy media within the steelworks. In particular, the optimized strategy allows rescheduling the POGs flows to the power plant when the internal consumers are not available, by saving huge amounts of NG and by avoiding flaring into torches, with a significant reduction of the environmental impact.

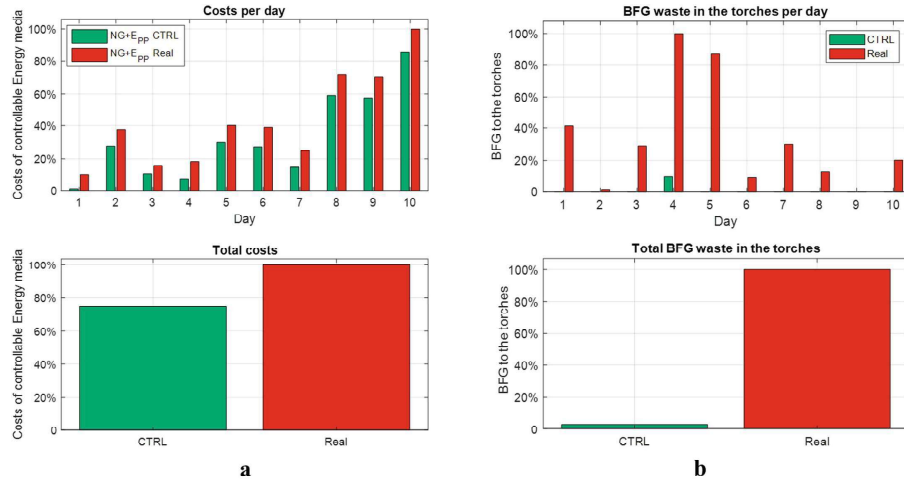

**Fig. 3.** Results of the optimization strategy for 10 days of quite constant pig iron, steel and of refined products production.

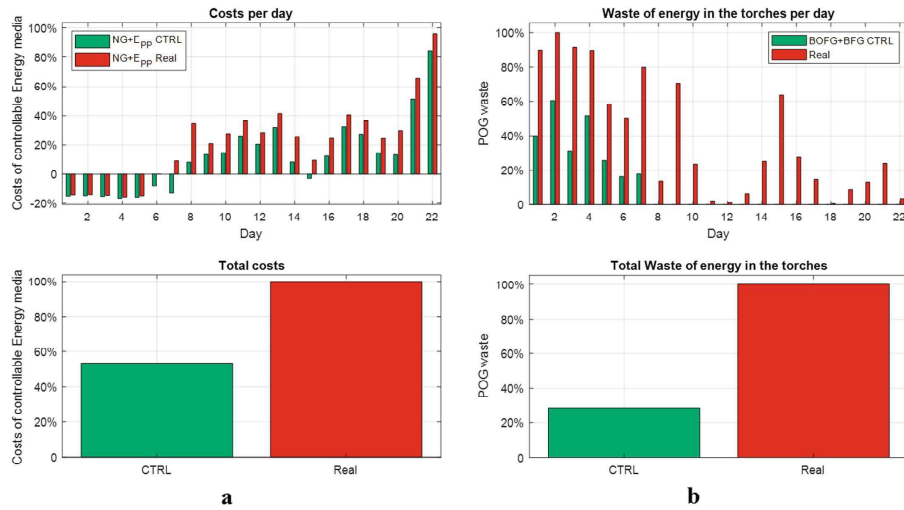

**Fig. 4.** Results of the optimization strategy for 22 days of non-constant production.

## 6 Conclusions

The paper provides an overview of a DSS which optimizes the distribution and usage of process off-gases in integrated steelworks, by filling the gaps of standard gas and steam networks management procedures. The core of the DSS are the library of forecasting models and the optimization tool. The models forecast the production and demand of the energy carriers that are involved in the management of the considered

distribution networks. ML-based approaches, and in particular ESN, DESN and FFNN, are intensively applied to capture the dynamic of the processes and suitable accuracy for optimization purposes were obtained. The optimization strategy is based on LP and MILP formulations and it is structured as a hierarchical multi-horizon control system and highly benefits from the accuracy and low computational burden of the ML-based models, by achieving very encouraging results. In particular, the hierarchical control system based on EMPC allows reducing the controllable portion of external energy sources between 27.5–46.3% and the exploitation of POG torches between 71.6–96.9% with respect to standard non-optimized management of the POGs flows in the network.

The described application provides a relevant example of application of Artificial Intelligence in order to lower the environmental impact of the steel production processes by also providing a friendly support to the decision processes of the human operators. This shows that the ongoing digitalization process of the steel sector [45], while preserving the centrality of the human role in decision-making, represents a powerful enabler for the improvement of the environmental footprint of the European steel sector and its transition towards an energy-efficient and Carbon-neutral production.

**Acknowledgments.** The work described in the paper was developed within the project “*Optimization of the management of the process gases network within the integrated steelworks - GASNET*” (Contract No. RFSR-CT-2015-00029) and received funding from the Research Fund for Coal and Steel of the European Union, which is gratefully acknowledged. The sole responsibility of the issues treated in the present paper lies with the authors; the Union is not responsible for any use that may be made of the information contained therein.

## References

1. EUROFER, European Steel in Figures (2020). <https://www.eurofer.eu/>. Accessed 15 Oct 2020
2. EC, What is the European Green Deal?. <https://ec.europa.eu>. Accessed 15 Oct 2020
3. Janjua, R.: Energy use in steel industry, World Steel Association. <http://www.iipinetwork.org>. Accessed 15 Oct 2020
4. Steelanol Homepage. <http://www.steelanol.eu/en>. Accessed 15 Oct 2020
5. Wich, T., Lueke, W., Deerberg, G., Oles, M.: Carbon2Chem-CCU<sup>®</sup> as a step toward a circular economy. *Front. Energy Res.* **7**, p. 162 (2020)
6. Deerberg, G., Oles, M., Schlögl, R.: The project Carbon2Chem<sup>®</sup>. *Chem. Ing. Tec.* **90**(10), 1365–1368 (2018)
7. Zaccara, A., Petrucciani, A., Matino, I., Branca, T.A., Dettori, S., Iannino, V., Colla, V., Bampaou, M., Panopoulos, K.: Renewable hydrogen production processes for the off-gas valorization in integrated steelworks through hydrogen intensified methane and methanol syntheses. *Metals* **10**(11), 1535 (2020)
8. Maruoka, N., Akiyama, T.: Exergy recovery from steelmaking off-gas by latent heat storage for methanol production. *Energy* **31**, 1632–1642 (2006)
9. Kim, D., Han, J.: Techno-economic and climate impact analysis of carbon utilization process for methanol production from blast furnace gas over Cu/ZnO/Al<sub>2</sub>O<sub>3</sub> catalyst. *Energy* **198**, 117355 (2020)

10. Gao, R., Zhang, C., Kwak, G., Lee, Y.J., Kang, S.C., Guan, G.: Techno-economic evaluation of methanol production using by-product gases from iron and steel works. *Energy Convers. Manag.* **213**, 112819 (2020)
11. Shin, S., Lee, J.-K., Lee, I.-B.: Development and techno-economic study of methanol production from coke-oven gas blended with Linz Donawitz gas. *Energy* **200**, 117506 (2020)
12. Dreillard, M., Broutin, P., Briot, P., Huard, T., Lettat, A.: Application of the DMXTM CO<sub>2</sub> capture process in steel industry. *Energy Procedia* **114**, 2573–2589 (2017)
13. Zhang, Q., Gu, Y.L., Ti, W., Cai, J.J.: Supply and demand forecasting of blast furnace gas based on artificial neural network in iron and steel works. *Adv. Mater. Res.* **443**, 183–188 (2012)
14. Yang, L., He, K., Zhao, X., Lv, Z.: The prediction for output of blast furnace gas based on genetic algorithm and LSSVM. In: *IEEE 9th Conference Industrial Electronics and Applications (ICIEA)*, pp. 1493–1498 (2014)
15. Zhao, J., Wang, W., Liu, Y., Pedrycz, W.: A two-stage online prediction method for a blast furnace gas system and its application. *IEEE Trans. Control Syst. Technol.* **19**(3), 507–520 (2011)
16. Zhao, J., Liu, Q., Wang, W., Pedrycz, W., Cong, L.: Hybrid neural prediction and optimized adjustment for coke oven gas system in steel industry. *IEEE Trans. Neural Networks Learn. Syst.* **23**(3), 439–450 (2012)
17. Liu, Y., Liu, Q., Wang, W., Zhao, J., Leung, H.: Data-driven based model for flow prediction of steam system in steel industry. *Inf. Sci.* **193**, 104–114 (2012)
18. Porzio, G.F., Fornai, B., Amato, A., Matarese, N., Vannucci, M., Chiappelli, L., Colla, V.: Reducing the energy consumption and CO<sub>2</sub> emissions of energy intensive industries through decision support systems—an example of application to the steel industry. *Appl. Energy* **112**, 818–833 (2013)
19. Porzio, G.F., Colla, V., Matarese, N., Nastasi, G., Branca, T.A., Amato, A., Fornai, B., Vannucci, M., Bergamasco, M.: Process integration in energy and carbon intensive industries: an example of exploitation of optimization techniques and decision support. *Appl. Therm. Eng.* **70**(2), 1148–1155 (2014)
20. Porzio, G.F., Nastasi, G., Colla, V., Vannucci, M., Branca, T.A.: Comparison of multi-objective optimization techniques applied to off-gas management within an integrated steelwork. *Appl. Energy* **136**, 1085–1097 (2014)
21. Maddaloni, A., Porzio, G., Nastasi, G., Colla, V., Branca, T.: Multi-objective optimization applied to retrofit analysis: a case study for the iron and steel industry. *Appl. Therm. Eng.* **91**, 638–646 (2015)
22. Zhao, X., Bai, H., Lu, X., Shi, Q., Han, J.: A MILP model concerning the optimisation of penalty factors for the short-term distribution of byproduct gases produced in the iron and steel making process. *Appl. Energy* **148**, 142–158 (2015)
23. Kong, H., Qi, E., Li, H., Li, G., Zhang, X.: A MILP model for optimization of by-product gases in the integrated iron and steel plant. *Appl. Energy* **87**, 2156–2163 (2009)
24. de Oliveira Junior, V.B., Pena, J.C., Salles, J.F.: An improved plant-wide multiperiod optimization model of a byproduct gas supply system in the iron and steel-making process. *Appl. Energy* **164**, 462–474 (2016)
25. Maddaloni, A., Matino, R., Matino, I., Dettori, S., Zaccara, A., Colla, V.: A quadratic programming model for the optimization of off-gas networks in integrated steelworks. *Matér. Tech.* **107**(5), p. 502 (2019)
26. Colla, V., Matino, I., Dettori, S., Cateni, S., Matino, R.: Reservoir computing approaches applied to energy Management in industry. *Commun. Comput. Inf. Sci.* **1000**, 66–79 (2019)

27. Cateni, S., Colla, V., Nastasi, G.: A multivariate fuzzy system applied for outliers detection. *J. Intell. Fuzzy Syst.* **24**(4), 889–903 (2013)
28. Cateni, S., Colla, V., Vannucci, M.: A fuzzy logic-based method for outliers detection. In: *Proceedings of the IASTED International Conference on Artificial Intelligence and Applications, AIA 2007*, pp. 561–566 (2007)
29. Cateni, S., Colla, V., Vannucci, M.: General purpose input variables extraction: a genetic algorithm based procedure GIVE a GAP. In: *9th International Conference on Intelligent Systems Design and Applications, ISDA 2009*, pp. 1278–1283 (2009)
30. Cateni, S., Colla, V., Vannucci, M.: A genetic algorithm-based approach for selecting input variables and setting relevant network parameters of a SOM-based classifier. *Int. J. Simul. Syst. Sci. Technol.* **12**(2), 30–37 (2011)
31. Vannucci, M., Porzio, G.F., Colla, V., Fornai, B.: Use of clustering and interpolation techniques for the time-efficient simulation of complex models within optimization tasks. In: *2011 UKSim 5th European Symposium on Computer Modelling and Simulation, IEEE*, pp. 6–11 (2011)
32. Jaeger, H.: The “echo state” approach to analysing and training recurrent neural networks—with an erratum note. *Bonn, Ger. Ger. Natl. Res. Center Inf. Technol. GMD Tech. Rep.* **148**(34), 13 (2001)
33. Jaeger, H., Haas, H.: Harnessing nonlinearity: predicting chaotic systems and saving energy in wireless communication. *Science* **304**(5667), 78–80 (2004)
34. Grigoryeva, L., Ortega, J.P.: Echo state network are universal. *Neural Networks* **108**, 495–508 (2018)
35. Deihimi, A., Showkati, H.: Application of echo state networks in short-term electric load forecasting. *Energy* **39**(1), 327–340 (2012)
36. Shi, G., Liu, D., Wei, Q.: Energy consumption prediction of office buildings based on echo state networks. *Neurocomputing* **216**, 478–488 (2016)
37. Gallicchio, C., Micheli, A.: Echo state property of deep reservoir computing networks. *Cogn. Comput.* **9**(3), 87–99 (2017)
38. Gallicchio, C., Micheli, A., Pedrelli, L.: Design of deep echo state networks. *Neural Networks* **108**, 33–47 (2018)
39. Wolff, A., Mintus, F., Bialek S., Dettori, S., Colla V.: Economical mixed-integer model predictive controller for optimizing the sub-network of the BOF gas, METEC 4<sup>th</sup> ESTAD, Düsseldorf (2019)
40. Dettori, S., Matino, I., Colla, V., Speets, R.: Deep echo state networks in industrial applications. In: *IFIP Advances in Information and Communication Technology*, 584 IFIP, pp. 53–63 (2020)
41. Matino, I., Dettori, S., Colla, V., Weber, V., Salame, S.: Forecasting blast furnace gas production and demand through echo state neural network-based models: pave the way to off-gas optimized management. *Appl. Energy* **253**, 113578 (2019)
42. Matino, I., Dettori, S., Colla, V., Weber, V., Salame, S.: Application of echo state neural networks to forecast blast furnace gas production: pave the way to off-gas optimized management. *Energy Procedia* **158**, 4037–4042 (2019)
43. Dettori, S., Matino, I., Colla, V., Weber, V., Salame, S.: Neural Network-based modeling methodologies for energy transformation equipment in integrated steelworks processes. *Energy Procedia* **158**, 4061–4066 (2019)
44. Matino, I., Dettori, S., Colla, V., Weber, V., Salame, S.: Two innovative modelling approaches in order to forecast consumption of blast furnace gas by hot blast stoves. *Energy Procedia* **158**, 4043–4048 (2019)
45. Branca, T.A., Fornai, B., Colla, V., Murri, M.M., Streppa, E., Schröder, A.J.: The challenge of digitalization in the steel sector. *Metals* **10**(2), 288 (2020)