



**HAL**  
open science

## Impact of Intraoral Scanner Sleeves on STL File Accuracy: A Metrological Approach

Max Troizier Cheyne, Nicolas Lebon, Floriane Laverne

### ► To cite this version:

Max Troizier Cheyne, Nicolas Lebon, Floriane Laverne. Impact of Intraoral Scanner Sleeves on STL File Accuracy: A Metrological Approach. *Computer-Aided Design and Applications*, 2023, 21 (4), pp.567-580. 10.14733/cadaps.2024.567-580 . hal-04284162

**HAL Id: hal-04284162**

**<https://hal.science/hal-04284162>**

Submitted on 17 Nov 2023

**HAL** is a multi-disciplinary open access archive for the deposit and dissemination of scientific research documents, whether they are published or not. The documents may come from teaching and research institutions in France or abroad, or from public or private research centers.

L'archive ouverte pluridisciplinaire **HAL**, est destinée au dépôt et à la diffusion de documents scientifiques de niveau recherche, publiés ou non, émanant des établissements d'enseignement et de recherche français ou étrangers, des laboratoires publics ou privés.



Open licence - etalab



## Impact of Intraoral Scanner Sleeves on STL File Accuracy: A Metrological Approach

Max Troizier Cheyne<sup>1</sup> , Nicolas Lebon<sup>2</sup>  and Floriane Laverne<sup>3</sup> 

<sup>1</sup>URB2I, UR 4462, Université Paris Cité, F-92049, Montrouge, France, [max.troizier@etu.u-paris.fr](mailto:max.troizier@etu.u-paris.fr)

<sup>2</sup>URB2I, UR 4462, Université Sorbonne Paris Nord, F-93000, Bobigny, France,  
Léonard de Vinci Pôle Universitaire, Research Center, 92916 Paris La Défense, France  
[nicolas.lebon@devinci.fr](mailto:nicolas.lebon@devinci.fr)

<sup>3</sup>URB2I, UR 4462, Université Sorbonne Paris Nord, F-93000, Bobigny, France,  
[laverne@univ-paris13.fr](mailto:laverne@univ-paris13.fr)

Corresponding author: Max Troizier Cheyne, [max.troizier@etu.u-paris.fr](mailto:max.troizier@etu.u-paris.fr)

**Abstract.** Intraoral scanners (IOS) are essential tools in dental prosthodontics, enabling efficient digitization of dental arches for CAD-CAM workflows. The Primescan IOS (Dentsply Sirona) can be fitted with three scanning sleeves, based on the level of hygiene imposed by the clinical situation and health regulations: a standard sleeve (SS), an autoclavable sleeve (AS), and a disposable sleeve (DS). Most studies evaluating accuracy use local best-fit algorithms to superimpose a reference scan and a test scan, providing relative accuracy. This study proposes an alternative evaluation method based on metrological principles and aims to compare the quality of scans taken with the three types of sleeves. An 8 mm aluminum oxide sphere was scanned 24 times using each sleeve. Mesh analysis was conducted, and measures of trueness, precision, and digitizing noise were calculated. Significant differences in trueness were identified between AS-DS ( $p < 0.001$ ) as well as AS-SS ( $p < 0.001$ ), while no significant differences were found between the sleeves for precision ( $p = 0.623$ ). Significant differences in digitizing noise were also identified between DS-AS ( $p < 0.001$ ), DS-SS ( $p = 0.001$ ), and SS-AS ( $p = 0.001$ ). This study tested the scanning quality of an IOS fitted with different sleeves using absolute measures as opposed to relative measures, and though statistically significant differences were found, within the experimental conditions, the errors appear to be within clinically accepted limits.

**Keywords:** Intraoral Scanner, Scanning Sleeves, Accuracy Evaluation, Trueness, Precision, Noise

**DOI:** <https://doi.org/10.14733/cadaps.2024.567-580>

## 1 INTRODUCTION

With the growing utilization of Computer-Aided Design and Computer-Aided Manufacturing (CAD-CAM) technologies in dental prosthodontics, intraoral scanners (IOS) that allow rapid digitizing of the dental arches have become integral to routine procedures. The advent of CAD-CAM systems offers quick and efficient production of prostheses and IOS have been shown to improve patient comfort compared to conventional methods, reduce treatment time, and facilitate communication between both clinicians and their laboratory technicians and clinicians and their patients [1]. A 2021 study by the American Dental Association identified that 53% of surveyed dentists used an intraoral scanner in their daily practice [2]. As increased computing power and IOS performance has broadened the clinical uses of these devices and costs decrease, IOS seem poised to replace conventional impression methods using dental trays and impression materials such as polyvinylsiloxane (PVS) or alginate.

Intraoral scanners represent the first element in the digital prosthodontic workflow (Figure 1). In both digital workflows and conventional methods, errors accumulate at each successive step [3]. Conventional impression procedures are prone to errors during and after registration as PVS materials are naturally hydrophobic, and alginate is unstable through time because of water loss [4]. Dental stone also expands due to secondary reactions during setting [5]. In the digital workflow, intraoral scans are digitized and as such are dimensionally stable once completed. However, the scan accuracy is influenced by many factors during the scan, such as the presence of blood or saliva, scan path, patient movement, operator experience, ambient lighting conditions, tooth morphology, and preparation design all affect the quality of the optical scan [6]–[10].

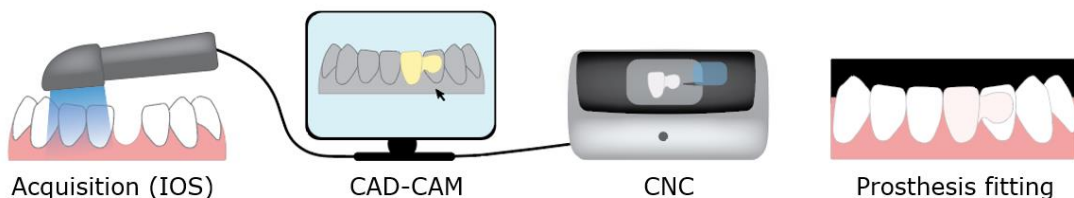

**Figure 1:** Illustration of the digital workflow in dentistry.

For both digital and conventional workflows, errors in the beginning are amplified in the final product. As such, it is paramount to obtain the highest quality scan as it represents the first link in the CAD-CAM chain (Figure 1). Scanner accuracy is crucial and is the focus of a growing body of research.

Current literature suggests that the leading intraoral scanners produce more accurate digital casts than conventional methods for single-tooth and short-span impressions [11], [12]. For more extensive impressions, such as full-arch impressions, most authors still find conventional techniques superior, though recent studies on newer IOS are starting to refute these findings using metrological criteria to assess accuracy [13], [14]. Traditionally, accuracy, as defined by the International Organization for Standardization standard 5725-1:1994, is evaluated by two measures: trueness and precision [15]. Trueness refers to how close the average of numerous test results aligns with a true or accepted reference value, while precision pertains to the agreement between independent measurement results obtained under specified conditions [15]. Trueness is essential in prosthodontics as an IOS must be able to generate a digital model that is as close to the real clinical situation as possible. Precision is also important, as a restoration is made off of a single scan, so an IOS that systematically obtains very close results, is desirable [16].

Digitizing noise has also been presented as a metric of interest in evaluating IOS [17]. Noise refers to the random artifacts of signal that are introduced during the recording. Digitizing noise informs on the regularity of digitizing of canonic elements, such as planes and spheres, by characterizing the random measurement error of the system [18].

Most studies assessing accuracy confront meshes obtained by IOS and meshes produced by highly accurate laboratory scanners. The two meshes are superimposed using best-fit algorithms and the deviations between the reference and test meshes are used to obtain measures of accuracy such

as trueness and precision [16], [19]. This type of analysis allows evaluation of the relative error between several IOS based off a reference scan but is unable to provide absolute values for trueness and precision. Superimposition is done by iterative closest point algorithms, which minimizes deviations across the entire object [20]. It is technically impossible to compare two identical points on separate meshes to obtain a single measure. Studies using reference geometries [21] or additional image processing [20] have shown that the best-fit approach results in an underestimation of error values and their distribution over the entire object.

To obtain actual trueness and precision values, metrological principles must be applied. Metrology compares test measures to the known dimension of a measurand. Reference objects used for metrological studies and calibration are manufactured to various grades of accuracy. Scans of a near-perfect geometric shape can be used to evaluate real errors and evaluate trueness and precision, as well as digitizing noise [22]. The use of calibrated reference objects allows the evaluation of dimensional trueness and precision, which are based off representative measures (e.g. diameter for a sphere, width, and length for a gauge block) constructed on the point cloud generated by the scanner.

Several recent studies identify the Primescan (Dentsply Sirona) as among the most accurate IOS on the market [14], [19], [22], [23]. This handheld camera uses confocal imaging technology and video recording to acquire the subject. The handpiece is composed of an optical sensor, a mirror, and a protective sleeve which contacts the oral cavity during scanning. The COVID-19 pandemic brought renewed attention to the importance of infection prevention practices in the dental setting, most notably by reducing patient volume to allow proper disinfection and ventilation procedures as well as the donning of appropriate personal protective equipment [24]. In their 2016 guidelines on infection prevention, the American Centers for Disease Control and Prevention recommends that semicritical items, which contact mucous membranes or non-intact skin, should be sterilized using heat, or at minimum processed using high-level disinfection, noting that exposure to infectious materials may occur if dental handpieces and their attachments are not heat sterilized as disinfectant solutions cannot properly clean the internal components of the tools [25]. The standard scanning sleeve of the Primescan IOS can be dry heat sterilized, processed through high-level disinfection, or simply wiped down with disinfecting wipes according to the manufacturer instructions [26]. Dentsply Sirona, the manufacturer of the Primescan has recently released two new types of protective sleeves to meet more rigorous hygiene protocols. One sleeve is fully autoclavable and the other is disposable.

An IOS should provide a digital model that is both true to the dimensions and geometry of the object but also a model that is repeatable when multiple scans are performed [11]. Proper sanitation protocols are imperative to reduce cross-contamination and manufacturers have offered tools adapted to various protocols. The object of this study is to compare the trueness, precision, and digitizing noise of scans taken with the autoclavable (AS) and disposable sleeves (DS) as well as with the standard sleeve (SS) that is sold with each Primescan IOS, using metrological methods. The null hypothesis is that no differences in trueness, precision, or digitizing noise exists between the different types of sleeves.

## 2 MATERIALS AND METHODS

In this section, the materials and methods are developed and summarized in Figure 2.

### 2.1 Scanning Protocol

The IOS used in this study was the Primescan and the associated software was CEREC Software version 5.2.2. The Primescan IOS is sold with a standard sleeve (SS) composed of a stainless-steel body and a highly scratch-resistant coated sapphire glass window. The window sleeve is classified as a "semi critical medical device A" according to the Robert Koch Institute (Berlin, Germany) and as such, does not need to be sterilized [26]. For those clinicians who wish to adopt more stringent hygiene protocols, the manufacturer also produces an autoclavable sleeve with a disposable window and a fully disposable sleeve. The autoclavable sleeve (AS) is composed of a stainless-steel body

which is fully moist-heat autoclavable and has a single-use PMMA window that is snugly fitted to the body. The disposable sleeve (DS) combines a plastic sleeve with a PMMA window already fitted. The SS served as the control in this study.

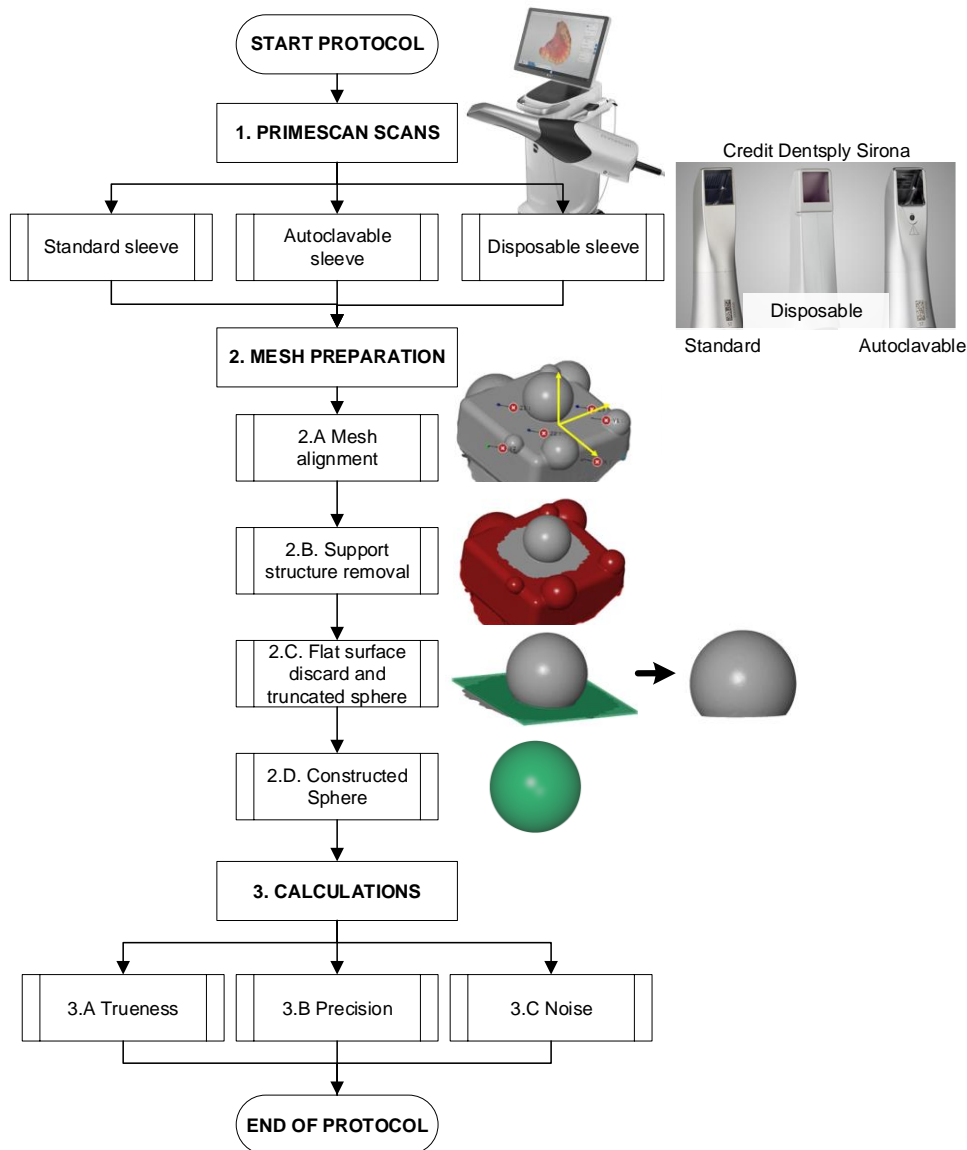
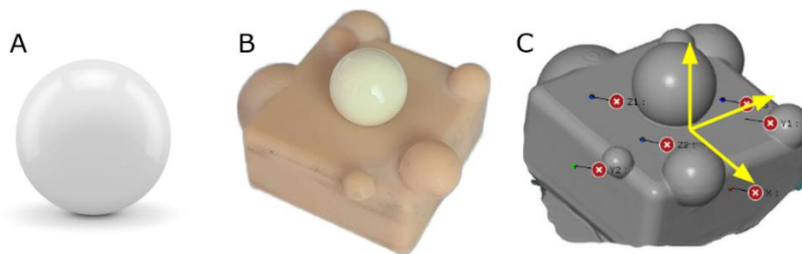

**Figure 2:** Materials and methods flowchart.

The reference object selected was an 8 mm aluminum oxide sphere (Figure 3(a)), manufactured by CIMAP to a Grade 10 standard according to ISO 3290:2002. An 8 mm sphere was chosen as it is approximately the size of a human molar and comprises smooth convex surfaces like those found in natural teeth. Aluminum oxide was chosen as it is a dimensionally stable, wear-resistant material that was widely used as a restorative material and has similar optical properties to enamel. IOS were designed to scan these types of materials and so an aluminum oxide sphere serves as a good model of teeth.

ISO 20896-1, the standard for assessing intraoral scanners, stipulates that the standard uncertainty in the reference values of the dimensions of interest must be no greater than one-fifth the accuracy expected of the intraoral scanner [27]. Grade 10 spheres (ISO 3290-2) have a maximum diameter variation of  $0.25\ \mu\text{m}$  and previous studies have found errors within the tens of microns range for the Primescan [22], [23], [28], [29]. The dimensional accuracy of the sphere is well within the conditions stipulated by ISO 20896-1.

A 3D printed base with spherical topographical landmarks was created to improve the scanning ability of the scanner by introducing a non-symmetrical shape (Figure 3(b)). This was necessary as strictly symmetrical objects can hinder the scanner's image recording and image processing ability [30], [31]. The base was designed using CAD software (Catia V5, Dassault Systems) and then 3D printed in Model V2 resin (Formlabs 3B, Formlabs) with a  $25\ \mu\text{m}$  layer thickness. The rectangular nature of the structure allowed for easy creation of a coordinate system in the mesh processing stage.



**Figure 3:** (a) Photograph of the grade 10 aluminum oxide reference sphere, (b) the reference sphere on its 3D printed support, (c) Mesh after 3-2-1 alignment.

Before each series of scans, the sleeve was fitted to the IOS, and a calibration was performed according to manufacturer instructions. Per the manufacturer, the disposable sleeves should not be used for calibration, and instead a calibration using the standard sleeve should be used, then the DS fitted. Indeed, the calibration module does not fully seat on the disposable sleeve. Presumably this is because the disposable sleeve is meant to be used according to the most stringent cross-contamination protocols.

Twenty-four scans of the sphere and support structure were performed using each type of sleeve. All scans were carried out in a single day and by a single operator, to retain near identical conditions for each scan. Window blinds were closed to minimize error stemming from external lighting, room temperature remained identical, and the room lights were left on. All scans were performed using a circular motion lasting a maximum of 15 seconds. Care was taken to use the same scan pattern as variations in scan pattern affect accuracy [32]. Leon et al. found that deleting portions of mesh and rescanning negatively influenced the accuracy of the IOS, so if a scan was incomplete or had erratic geometries the whole scan was redone [33]. After each scan, the STL file was exported in the highest-quality format according to the software options, and finally imported into GOM Inspect (GOM Software 2022, Rev. 154413, Build 2022-09-09), a reverse engineering tool used for metrological analysis.

## 2.2 Mesh Preparation

Before analysis, a reference coordinate system was created, and the relevant mesh was isolated.

A reference coordinate system was created using the 3-2-1 alignment tool on the surfaces of the 3D printed structure (Figure 3(c)) This plane, line, point, alignment tool establishes a coordinate system by selecting three points on a plane to define the z axis, defining a line to lock rotation around the z axis, and defining a point to lock translation in the X and Y axes. The resulting coordinate system is the same for each scan.

The mesh corresponding to the support structure was then deleted to preserve only the sphere and a portion of the surrounding flat surface (Figure 2(b)). The remaining flat surface was discarded by fitting a Gaussian plane and a parallel plane 0.2 mm above it, then deleting the mesh below the parallel plane, leaving only the mesh corresponding to the truncated sphere (Figure 2(c)).

A constructed sphere was produced based on the remaining mesh using a Gaussian fit algorithm which associates a sphere to the point cloud using the least squares method (Figure 2(d)). The coordinates of the point cloud in the previously constructed coordinate system were exported in ASCII format and the dimension of interest, the diameter of each constructed sphere, was recorded.

### 2.3 Calculation of Trueness, Precision, and Digitizing Noise

All calculations presented below were performed using Python. Trueness ( $T$ ) for each studied scanning sleeve is the deviation of measurements from the reference value, as given by the equation (2.1):

$$T = \bar{d} - d_R \quad (2.1)$$

where  $T$  is the trueness (also called bias) of the measured diameter,  $\bar{d}$  is the mean of the 24 diameters of the constructed spheres, and  $d_R$  is the reference diameter of the sphere (8 mm).

Precision ( $P$ ) is the closeness of agreement between independent results and is usually expressed as the standard deviation of the results [31]. The precision of the measurements using each type of sleeve was calculated following equation (2.2):

$$P = \sqrt{\frac{1}{n-1} \sum_{i=1}^{n=24} (d_i - \bar{d})^2} \quad (2.2)$$

To calculate digitizing noise, the values of the radius for each point in the dot-cloud must be obtained. For each point  $A_j$  among the  $m$  points of each scan of coordinate  $(x_j, y_j, z_j)$  extracted from the ASCII file, the distance ( $r_j$ ) between point  $A_j$  and the center of the constructed sphere was calculated as follows:  $r_j = \sqrt{x_j^2 + y_j^2 + z_j^2}$ . Then, the digitizing noise ( $\sigma_N$ ) of each point cloud, which can be assimilated to the standard deviation of the radii, was calculated with equation (2.3):

$$\sigma_N = \sqrt{\frac{1}{m-1} \sum_{j=1}^m (r_j - \bar{r})^2} \quad (2.3)$$

Finally, the mean digitizing noise ( $\overline{\sigma_N}$ ) was then calculated for each sleeve type using the 24 values for  $\sigma_N$ .

Statistical analysis was performed in Python. The assumption of normality and homoscedasticity of the grouped data were evaluated with the Shapiro-Wilk test and Levene's test, respectively. If either test failed, then a Kruskal-Wallis test was implemented and a Mann-Whitney U test with Bonferroni correction was then performed to evaluate multiple comparisons. The level of significance was set at 0.05. The results are presented in the following section and are summarized in Table 1.

## 3 RESULTS

In this section, all results for trueness, precision, and digitizing noise are developed and summarized in Table 1.

### 3.1 Trueness and Precision

The trueness ( $T$ ) for each sleeve was  $-9.72 \mu\text{m}$  for the SS,  $-9.66 \mu\text{m}$  for the DS, and  $2.55 \mu\text{m}$  for the AS. The precision for the sleeves was calculated to be  $6.71 \mu\text{m}$  for the SS,  $7.99 \mu\text{m}$  for the DS, and  $7.91 \mu\text{m}$  for the AS. The boxplots describing the data are presented in Figure 4. A Shapiro-Wilk test



on each group failed to reject the null hypothesis for the AS ( $W = 0.968$ ,  $p = 0.620$ ), the DS ( $W = 0.964$ ,  $p = 0.531$ ), and the SS ( $W = 0.928$ ,  $p = 0.087$ ). The Levene's test failed to reject the null hypothesis ( $W = 0.477$ ,  $p = 0.623$ ) as well. Based on this outcome, a One-way ANOVA test was performed on the diameters of the constructed spheres.

The ANOVA test identified a significant difference in the diameters of the constructed spheres between the different sleeve types,  $F(2) = 22.613$ ,  $p < 0.001$ . Post-hoc comparisons using the Tukey HSD test indicated that the mean diameters using AS were significantly greater than the mean diameters using the DS ( $p < 0.001$ ) and the SS ( $p < 0.001$ ). No significant difference was identified between the DS and SS ( $p = 0.999$ ).

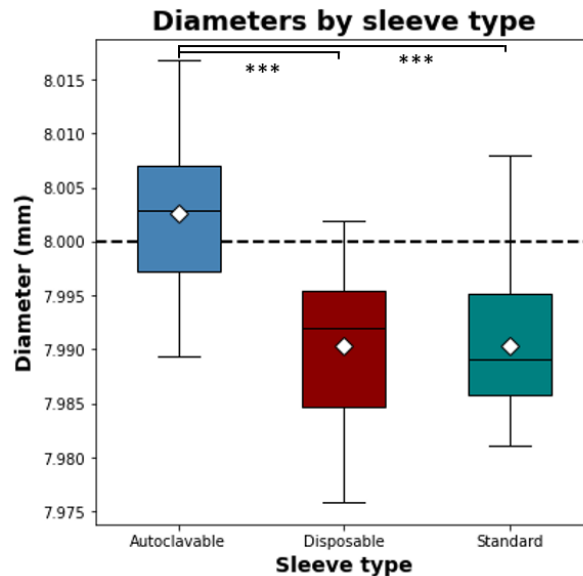

**Figure 4:** Boxplot diagrams of the diameters by sleeve type. \*\*\* indicates statistical significance of  $p < 0.001$ . The dashed line indicates the nominal diameter of 8 mm.

### 3.2 Digitizing Noise

The digitizing noise for each sleeve was  $7.31 \mu\text{m}$  for the SS,  $8.72 \mu\text{m}$  for the DS, and  $6.37 \mu\text{m}$  for the AS. The Shapiro-Wilk test rejected the null hypothesis for AS group ( $W = 0.748$ ,  $p < 0.001$ ) and the SS group ( $W = 0.916$ ,  $p = 0.048$ ). Based on this outcome, a Kruskal-Wallis one-way analysis of variance test was performed on the digitizing noise (Table 1).

The Kruskal-Wallis test showed that there is a significant difference in the digitizing noise between the different sleeve types,  $\chi^2(2, n = 108) = 27.879$ ,  $p < 0.001$ , with a mean rank score of 20.416 for the AS, 52.313 for the DS, and 36.770 for the SS. The post-hoc Mann Whitney U test using a Bonferroni corrected alpha of 0.017 ( $0.05/3$ ) indicated that the mean ranks were significantly different between DS-AS ( $U = 65.0$ ,  $p < 0.001$ ), DS-SS ( $U = 444.5$ ,  $p = 0.001$ ), and SS-AS ( $U = 125.0$ ,  $p = 0.001$ ).

Sleeve	Mean diameter ( $\bar{d}$ )	Trueness ( $T$ )	Precision ( $P$ )	Mean Digitizing Noise ( $\sigma_N$ )
Standard (SS) $n = 24$	7990.28 $\mu\text{m}$	-9.72 $\mu\text{m}$	6.71 $\mu\text{m}$	7.31 $\mu\text{m}$
Disposable (DS) $n = 24$	7990.34 $\mu\text{m}$	-9.66 $\mu\text{m}$	7.17 $\mu\text{m}$	8.72 $\mu\text{m}$



<i>Autoclavable (AS)</i> <i>n = 24</i>	8002.55 $\mu\text{m}$	2.55 $\mu\text{m}$	7.91 $\mu\text{m}$	6.37 $\mu\text{m}$
---	-----------------------	--------------------	--------------------	--------------------

**Table 1:** Summary of the results.

#### 4 ANALYSIS AND DISCUSSION

This study's purpose was to assess the trueness, precision, and digitizing noise of an IOS using three different scanning sleeves by using an objective method based on metrological principles. The null hypothesis that no significant differences in trueness, precision, or digitizing noise would be found when scanning using the three different sleeves was rejected for two parameters: trueness and digitizing noise.

Significant differences were found for trueness between the AS-DS and AS-SS, with the DS and SS yielding less true results. On average, the constructed spheres using the disposable sleeve and standard sleeve were smaller than the actual diameter of the reference sphere. However, the autoclavable sleeve yielded constructed spheres with larger diameters, on average, than the reference sphere. No significant difference was identified in precision amongst the three groups. These results suggest that, within these experimental conditions, scanning using the three different sleeves is precise though the AS tends to overestimate the size of the subject whereas the DS and SS tend to underestimate the size.

Significant differences in digitizing noise were also found between all pairs, with DS resulting in the greatest digitizing noise, followed by the SS, and finally the AS. Two other studies used a similar methodology to evaluate digitizing noise of IOS. Desoutter et al. proposed a protocol using polished alumina wafers as reference surfaces and compared the digitizing noise of two intraoral scanners to that of an atomic force microscope [17]. They defined digitizing noise as the root-mean-square (RMS) of the distance of each point in the point cloud from a mean plane fitted to the point-cloud, in effect calculating the standard deviation of the points. The study found significant differences in noise between points recorded by the center of the lens and those points on the borders of the image, referred to as edge effect. The impact of this edge effect on a tooth preparation or a dental arch scan remains unknown. The authors also found significant differences in noise when comparing the angle of scanning, though the impact was not uniform across the two IOS.

Dupagne et al. also evaluated digitizing noise of nine IOS using a reference 8 mm zirconia block as measurand and assimilating digitizing noise to the standard deviation of the distance between each point in the point cloud, and an adjusted plane fitted to the point cloud [22]. The study included the Primescan IOS for which the mean digitizing noise was evaluated to be  $3.2 \pm 0.6 \mu\text{m}$ . The differences between their results and the present results could be attributed to the object geometry or to surface texture. Dupagne et al.'s study applied aluminum oxide powder to facilitate scanning. The present results indicate values for digitizing noise almost double the values found by Dupagne et al., despite their study using a powder while this study did not. Object geometry may thus also influence the results, highlighting the added errors incorporated when scanning and evaluating more complicated organic objects such as teeth.

The results regarding noise are surprising. It was hypothesized that the SS would obtain the lowest noise as it has a fixed sapphire window. As the mirror of the Primescan remains fixed, only the sleeves are removed and replaced so any variation in parameters should be due to the sleeves, and more specifically the windows. However, though the DS and AS have windows made of the same material, their digitizing noise is different. The authors noted that, though the disposable windows of the AS were firmly fixed, the window of the DS was slightly mobile within its casing. Variations in window angle could lead to signal distortions and increased noise. The manufacturer also does not recommend the use of the DS or AS for color analysis [26]. This feature automatically analyzes the color of the tooth and suggests a shade for the clinician and laboratory technician. These recommendations could stem from the slightly differing optical properties of the PMMA and Sapphire windows, which could also affect the results.

Qualitative analysis of the surface comparisons between the constructed sphere and the mesh reveals similar patterns of deviation across scans from the three sleeves. Representative images of the surface comparisons are presented in Figure 5. The mesh is inside the constructed sphere in the upper pole by approximately 8  $\mu\text{m}$  (light blue), as well as near the base of the sphere by approximately 27  $\mu\text{m}$  (dark blue), whereas the mesh is outside the constructed sphere near the lower third by approximately 10  $\mu\text{m}$  (yellow). Assessment of accuracy using a single dimension such as the diameter of the constructed sphere also presents the limitation of summarizing the deviations across an entire object to a single value. Accuracy of the IOS is not evenly distributed across the scanned object. In a clinical setting, the margin of the tooth preparation is of particular importance; yet it is a site of sudden changes in direction as the gingiva are near the preparation margin. Similarly, to the zone at the base of the sphere, these areas may be susceptible to more important distortions.

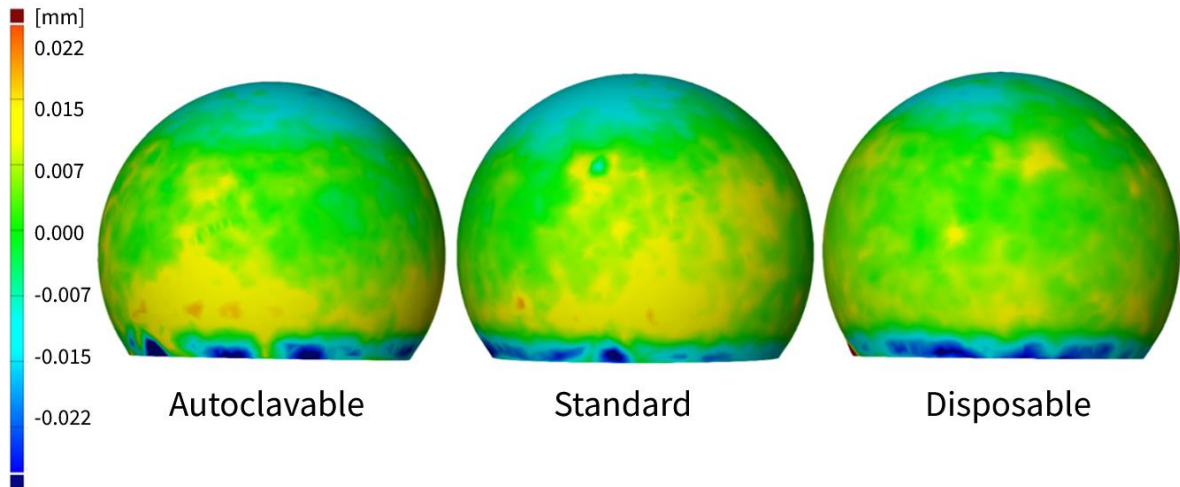

**Figure 5:** Surface comparisons of the mesh projected on the constructed spheres indicating the areas of distortion during scanning. Areas in orange-red indicate that the mesh was outside the constructed sphere, whereas teal-blue indicates the mesh was within the constructed sphere.

These results must also be analyzed in the context of required clinical accuracy. Marginal and internal adaptation of restorations both affect the longevity of restorations and in the digital workflow are directly dependent on the accuracy of the scan. A systematic review of by Goujat et al. found that poor marginal adaptation can lead to microleakage and dissolution of luting cement as well as caries and gingival inflammation while poor internal adaptation can reduce fracture resistance and result in poor marginal fit [34], [35]. They noted that no consensus has been achieved regarding ideal marginal fit and internal adaptation, though the most conservative authors suggest a marginal fit of less than 100  $\mu\text{m}$  while internal gaps of 50 to 100  $\mu\text{m}$  resulted in the most favorable cement performance. The results of the present study indicate errors that are compatible with these requirements.

As space for cement is always created to allow cementation, the magnitude of the errors between the three different sleeves appear to be subclinical. However, it is important to underline that errors accumulate at each step of the prosthesis conception and fabrication. Errors can stem from the milling device algorithms, the type of burs, the number of axes of the machine [34], [36], as well as dimensional variations that can occur during sintering [35]. Differences between sleeves may appear minimal at the scale of this study but may be more important when a prosthesis is fabricated.

It is difficult to draw conclusions on the applicability of these results on real-world intraoral acquisitions. In clinical applications there are many other factors affecting accuracy, such as tooth preparation geometry and proximity and orientation of adjacent teeth [9], [37], [38]. These results

are also applied to a tooth sized object which is most like a single-unit restoration scan whereas a full-arch scan is at least ten times larger and involves more complex shapes. It is plausible that the differences identified in this study could be more clinically significant if applied to a larger and more complex object.

To the author's knowledge, this is the first investigation of the different types of sleeves for the Primescan scanner. Only one other study on scanning sleeves (or tips as they are referred to in the article) was identified and was performed on the Emerald scanner (Planmeca USA Inc.) [32].

An et al. found that significant differences in trueness and precision when comparing a regular and small tip on an Emerald (Planmeca USA Inc) intraoral scanner on a typodont model [32]. The small sleeve has a smaller window and mirror than the regular sleeve, leading to a smaller field of view. The smaller sleeve's values for full-arch trueness ( $153 \pm 52 \mu\text{m}$ ) and precision ( $90 \pm 42 \mu\text{m}$ ) were 59% and 23% greater, respectively, than the regular sleeve size which were attributed to the smaller field of view and the greater number of images needing to be stitched together to reconstruct the 3D model, which has been identified as a source of errors [39]. Given that window size alone had a significant impact on the accuracy of IOS, we hypothesized that sleeves, and specifically the windows, made of different materials might also affect accuracy.

The authors identified some limitations in this study. Though the amount of digitizing noise was evaluated, the source of the noise could not be isolated. Many factors impact IOS accuracy and though an effort was made to control possible confounding factors it is possible that the differences observed in this study could arise from operator manipulation [6], [8]–[10]. These test were done in-vitro and the results cannot be directly applied to patients as the number of confounding factors increases and studies have shown that intraoral conditions affect the precision and trueness of IOS relative to in-vitro conditions [40].

Additional errors may have been introduced during the scanning and mesh analysis phases. A single operator performed the scans to reduce inter-operator variability, the same rotational scan pattern was used, and rest periods were introduced between scans to limit operator fatigue. Further studies could attempt to standardize measurements by using an automated system such as a rotating table and a fixed IOS or using a robotic arm as demonstrated by Strauß et al [41]. Extensive measures were taken to reduce errors during the mesh analysis phase by using a standardized protocol that involved limited operator input. However, distortions in the scanning phase could affect the segmentation of the sphere, though the authors believe that these errors would be minimal.

A single dimension, the diameter of the constructed sphere, was used to assess the trueness and precision. More measured dimensions would provide more data. ISO standard 2089-1:2019 describes methods to assess the accuracy of handheld digital impression devices in dentistry [27]. The standard proposes three reference objects with simple geometries to be analyzed: an inlay preparation (Figure 6(a)), a crown preparation (Figure 6(b)), and a dental-arch model with four spheres placed on the occlusal surfaces of the second molars and first premolars. Each object has several dimensions of interest such as height, width, conicity, as well as inter-object distance. For each scan performed, a single value for each dimension of interest is recorded upon analysis of the STL file. Calculations for trueness and precision are then performed individually for each dimension.

Future studies should consider analyzing trueness and precision using these ISO models as they contain more dimensions of interests to study and may offer more nuanced datasets. Of course, these models do not offer the same geometric complexity as the organic shapes of human teeth. The sphere fulfills the aim of this study which was to use objective metrological principles to evaluate IOS, something which cannot be directly applied to the more complex forms within the oral cavity.

Research into the effect of cumulative infection prevention protocols (eg. dry-heat sterilization, antiseptic wipes) on the standard sleeve should also be undertaken to see if they have a measurable effect on the quality of scans. Barenghi et al. highlight that IOS constitute a novelty in the prevention of communicable diseases, by reducing the potential vectors of transmission to the lab as no impression trays, impression materials, or gypsum casts are used [42].

Of note, other IOS such as the i700 (Medit Corp.) and the Trios 4 (3Shape Global) sell autoclavable sleeves that notably have no windows. Whereas the mirror of the Primescan is fixed to

the handpiece, and the sleeves are removable, the i700 and the Trios 4 include the mirror in the removable sleeve, potentially exposing the mirror to oral fluids.

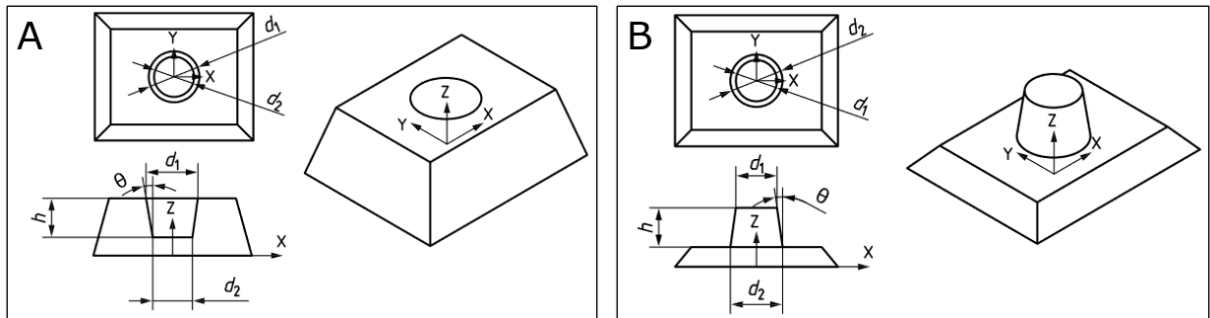

**Figure 6:** Inlay (a) and crown (b) reference objects according to ISO standard 2089-1[27].

Of note, the newest IOS from 3Shape, the Trios 5 employs a similar design to the Primescan, with a fixed mirror and removable sleeves that include sapphire glass windows. The rapidly expanding landscape of IOS emphasizes the need for constant assessment of new products. Further research is needed to validate the present study, as well as evaluate the effect of other scanning sleeves on other platforms.

## 5 CONCLUSIONS

This study proposed an evaluation method based on metrological principles and compared the quality of scans taken with the standard sleeve, the autoclavable sleeve, and the disposable sleeve proposed by Dentsply Sirona for their Primescan intraoral scanner. Precision, trueness, and digitizing noise of the scans were evaluated. Results indicated significant differences in trueness and digitizing noise between scans taken with the various scanning sleeves. Further study on models with more measurable parameters, such as the ISO inlay, crown, and full-arch models are needed to further assess scanning sleeve's effect on performance. Within the limitations of this study, it appears that all three sleeves have errors within clinical limits, though the autoclavable sleeve is significantly more true and produces the least digitizing noise. This metrological method developed could also serve as an objective test to analyze other intraoral scanners.

Max Troizier Cheyne, <https://orcid.org/0000-0001-9834-3826>

Nicolas Lebon, <https://orcid.org/0000-0002-4377-9849>

Floriane Laverne, <https://orcid.org/0000-0003-2391-5732>

## REFERENCES

- [1] Siqueira, R.; Galli, M.; Chen, Z.; Mendonça, G.; Mireilles, L.; Wang, H.; Chan, H.: Intraoral scanning reduces procedure time and improves patient comfort in fixed prosthodontics and implant dentistry: a systematic review, *Clinical Oral Investigations*, 25(12), 2021, 6517–6531, <https://doi.org/10.1007/s00784-021-04157-3>
- [2] Revilla-Leon, M.; Frazier, K.; da Costa, J.B.; Kumar P.; Duong M.; Khajotia S.; Urquhart O.: Intraoral scanners, *The Journal of the American Dental Association*, 152(8), 2021, 669–670, <https://doi.org/10.1016/j.adaj.2021.05.018>
- [3] Tapie, L.; Lebon, N.; Mawussi, B.; Fron-Chabouis, H.; Duret, F.; Attal, J.: Understanding dental CAD/CAM for restorations--accuracy from a mechanical engineering viewpoint, *International Journal of Computerized Dentistry*, 18(4), 2015, 343–367, <https://pubmed.ncbi.nlm.nih.gov/26734668/>

- [4] Faria, A.C.L.; Rodrigues, C.; Maedo, A.P.; Mattos, M.; Ribeiro, R.: Accuracy of stone casts obtained by different impression materials, *Brazilian Oral Research*, 22(4), 2008, 293–298, <https://doi.org/10.1590/S1806-83242008000400002>
- [5] Sanda, M.; Miyoshi, K.; Baba, K.: Trueness and precision of digital implant impressions by intraoral scanners: a literature review, *International Journal of Implant Dentistry*, 7(1), 2021, 97, <https://doi.org/10.1186/s40729-021-00352-9>
- [6] Rapone, B.; Palmisano, C.; Ferrara, E.; Di Venere, D.; Albanese, G.; Corsalini, M.: The Accuracy of Three Intraoral Scanners in the Oral Environment with and without Saliva: A Comparative Study, *Applied Sciences*, 10(21), 2020, 7762, <https://doi.org/10.3390/app10217762>
- [7] Müller, P.; Ender, A.; Joda, T.; Katsoulis, J.; Impact of digital intraoral scan strategies on the impression accuracy using the TRIOS Pod scanner, *Quintessence International*, 47(4), 2016, 343–349, <http://doi.org.10.3290/j.qi.a35524>
- [8] Resende, C.; Barbosa, T.; Moura, G.; Tavares, L.; Rizzante, F.; Georg,e F.; Neves, F.; Mendonça, G.: Influence of operator experience, scanner type, and scan size on 3D scans, *Journal of Prosthetic Dentistry*, 125(2), 2021, 294–299, <https://doi.org/10.1016/j.prosdent.2019.12.011>
- [9] Bernauer, S.; Müller, J.; Zitzman, N.; Joda, T.: Influence of Preparation Design, Marginal Gingiva Location, and Tooth Morphology on the Accuracy of Digital Impressions for Full-Crown Restorations: An In Vitro Investigation, *Journal of Clinical Medicine*, 9(12), 2020, 3984, <https://doi.org/10.3390/jcm9123984>
- [10] Revilla-León, M.; Subramanian, S.G.; Özcan, M.; Krishnamurthy, V.R.: Clinical Study of the Influence of Ambient Light Scanning Conditions on the Accuracy (Trueness and Precision) of an Intraoral Scanner, *Journal of Prosthodontics*, 29(2), 2020, 107–113, <https://doi.org/10.1111/jopr.13135>
- [11] Mangano, F.; Gandolfi, A.; Luongo, G.; Logozzo, S.: Intraoral scanners in dentistry: a review of the current literature, *BMC Oral Health*, 17(1), 2017, 149, <https://doi.org/10.1186/s12903-017-0442-x>
- [12] Abduo, J.: Accuracy of Intraoral Scanners: A Systematic Review of Influencing Factors, *European Journal of Prosthodontics and Restorative Dentistry*, 26, 2018, 101–121, [https://doi.org/10.1922/EJPRD\\_01752Abduo21](https://doi.org/10.1922/EJPRD_01752Abduo21)
- [13] Keul, C.; Güth, J.-F.: Accuracy of full-arch digital impressions: an in vitro and in vivo comparison, *Clinical Oral Investigations*, 24(2), 2020, 735–745, <https://doi.org/10.1007/s00784-019-02965-2>
- [14] Schmidt, A.; Klusmann, L.; Wöstmann, B.; Schlenz, M.A.: Accuracy of Digital and Conventional Full-Arch Impressions in Patients: An Update, *Journal of Clinical Medicine*, 9(3), 2020, 688, <https://doi.org/10.3390/jcm9030688>
- [15] International Organization for Standardization, ISO 5725-1:1994: Accuracy (trueness and precision) of measurement methods and results — Part 1: General principles and definitions.
- [16] Nagy, Z.; Simon, B.; Mennito, A.; Evans, Z.; Renne, W.; Vág, J.: Comparing the trueness of seven intraoral scanners and a physical impression on dentate human maxilla by a novel method, *BMC Oral Health*, 20(1), 2020, 97, <https://doi.org/10.1186/s12903-020-01090-x>
- [17] Desoutter, A.; Yusuf Solieman, O.; Subsol, G.; Tassery, H.; Cuisinier, F.; Fages, M.: Method to evaluate the noise of 3D intra-oral scanner, *PLoS ONE*, 12(8), 2017. e0182206, <https://doi.org/10.1371/journal.pone.0182206>
- [18] Dupagne, L.: Mise en place d'un protocole d'évaluation standardisé des systèmes d'acquisition en CFAO dentaire, Ph.D. Thesis, Université Sorbonne Paris Nord, Montrouge, 2022.
- [19] Ender, A.; Zimmermann, M.; Mehl, A.; Accuracy of complete- and partial-arch impressions of actual intraoral scanning systems in vitro, 22(1) 2019, 11-19, <https://doi.org/10.5167/UZH-180700>
- [20] Vág, J.; Nagy, Z.; Simon, B.; Mikolicz, A.; Kövér, E.; Mennito, A.; Evans, Z.; Renne, W.: A novel method for complex three-dimensional evaluation of intraoral scanner accuracy, *International Journal of Computerized Dentistry*, 22(3), 2019, 239–249, <https://pubmed.ncbi.nlm.nih.gov/31463488/>



- [21] Ciocca, L.; Maltauro, M.; Cimini, V.; Breschi, L.; Meneghello, R.: Outdoing best-fit approaches for the manufacturing accuracy evaluation of complete denture bases, *International Journal on Interactive Design and Manufacturing*, 17(3), 2022, 1389–1397, <https://doi.org/10.1007/s12008-022-01162-y>
- [22] Dupagne, L.; Tapie, L.; Lebon, N.; Mawussi, B.: Comparison of the acquisition accuracy and digitizing noise of 9 intraoral and extraoral scanners: An objective method, *Journal of Prosthetic Dentistry*, 128(5), 2022, 1032–1040, <https://doi.org/10.1016/j.prosdent.2021.02.005>
- [23] Diker, B.; Tak, Ö.: Comparing the accuracy of six intraoral scanners on prepared teeth and effect of scanning sequence, *Journal of Advanced Prosthodontics*, 12(5), 2020, 299, <https://doi.org/10.4047/jap.2020.12.5.299>
- [24] Diakonoff, H.; Jungo, S.; Moreau, N.; Mazevet, M.; Ejeil, A.-L.; Salmon, B.; Smail-Faugeron, V.; Patel S.: Application of recommended preventive measures against COVID-19 could help mitigate the risk of SARS-CoV-2 infection during dental practice: Results from a follow-up survey of French dentists, *PLoS ONE*, 16(12), 2021, e0261439, <https://doi.org/10.1371/journal.pone.0261439>
- [25] Centers for Disease Control and Prevention, US Dept of Health and Human Services, Summary of Infection Prevention Practices in Dental Settings: Basic Expectations for Safe Care, 2016, Available: <https://www.cdc.gov/oralhealth/infectioncontrol/pdf/safe-care2.pdf>
- [26] Dentsply Sirona: CEREC Primescan AC, Primescan AC - Operating Instructions, 2021
- [27] International Organization for Standardization, 2019, 20896-1: Dentistry - Digital impression devices - Part 1 : Methods for assessing accuracy.
- [28] Kim, R. J. Y.; Benic, G.I.; Park, J.-M.: Trueness of ten intraoral scanners in determining the positions of simulated implant scan bodies, *Scientific Reports*, 11(1), 2021, 2606, <https://doi.org/10.1038/s41598-021-82218-z>
- [29] Mangano, F. G.; Admakin, O.; Bonacina, M.; Lerner, H.; Rutkunas, V.; Mangano, C.: Trueness of 12 intraoral scanners in the full-arch implant impression: a comparative in vitro study, *BMC Oral Health*, 20(1), 2020, 263, <https://doi.org/10.1186/s12903-020-01254-9>
- [30] Uhm, S.-H.; Kim, J.-H.; Jiang, H.B.; Woo, C.-W.; Chang, M.; Kim, K.-N.; Bae, J.-M.; Oh, S.: Evaluation of the accuracy and precision of four intraoral scanners with 70% reduced inlay and four-unit bridge models of international standard, *Dental Materials Journal*, 36(1), 2017, 27–34, <https://doi.org/10.4012/dmj.2016-064>
- [31] Mehl, A.; Reich, S.; Beuer, F.; Güth, J.-F.: Accuracy, trueness, and precision – a guideline for the evaluation of these basic values in digital dentistry, *International Journal of Computerized Dentistry*, 24(4), 2021, 341–352, <https://pubmed.ncbi.nlm.nih.gov/34931770/>
- [32] An, H.; Langas, E.; Gill, A.: Effect of scanning speed, scanning pattern, and tip size on the accuracy of intraoral digital scans, *Journal of Prosthetic Dentistry*, 2022, <https://doi.org/10.1016/j.prosdent.2022.05.005>
- [33] Revilla-León, M.; Quesada-Olmo, N.; Gómez-Polo, M.; Sicilia, E.; Farjas-Abadia, M.; Kois, J. C.: Influence of rescanning mesh holes on the accuracy of an intraoral scanner: An in vivo study, *Journal of Dentistry*, 115, 2021, 103851, <https://doi.org/10.1016/j.jdent.2021.103851>
- [34] Goujat, A.; Abouelleil, H.; Colon, P.; Jeannin, C.; Pradelle, N.; Seux, D.; Grosogeat, B.: Marginal and internal fit of CAD-CAM inlay/onlay restorations: A systematic review of in vitro studies, *Journal of Prosthetic Dentistry*, 121(4), 2019, 590–597, <https://doi.org/10.1016/j.prosdent.2018.06.006>
- [35] Borba, M.; Cesar, P. F.; Griggs, J. A.; Della Bona, Á.: Adaptation of all-ceramic fixed partial dentures, *Dental Materials*, 27(11), 2011, 1119–1126, <https://doi.org/10.1016/j.dental.2011.08.004>
- [36] Zeltner, Z.; Sailer, I.; Mühlemann, S.; Özcan, M.; Hämmerle, C. H. F.; Benic, G. I.: Randomized controlled within-subject evaluation of digital and conventional workflows for the fabrication of lithium disilicate single crowns. Part III: marginal and internal fit, *Journal of Prosthetic Dentistry*, 117(3), 2017, 354–362, <https://doi.org/10.1016/j.prosdent.2016.04.028>

- [37] Son, S.-A.; Kim, J.-H.; Seo, D.-G.; Park, J.-K.: Influence of different inlay configurations and distance from the adjacent tooth on the accuracy of an intraoral scan, *Journal of Prosthetic Dentistry*, 128(4), 2022, 680–687, <https://doi.org/10.1016/j.prosdent.2020.12.044>
- [38] Ammoun, R.; Suprono, M. S.; Goodacre, C. J.; Oyoyo, U.; Carrico, C. K.; Kattadiyil, M. T.: Influence of Tooth Preparation Design and Scan Angulations on the Accuracy of Two Intraoral Digital Scanners: An in Vitro Study Based on 3-Dimensional Comparisons, *Journal of Prosthodontics*, 29(3), 2020, 201–206, <https://doi.org/10.1111/jopr.13148>
- [39] Mutwalli, H.; Braian, M.; Mahmood, D.; Larsson, C.: Trueness and Precision of Three-Dimensional Digitizing Intraoral Devices, *International Journal of Dentistry*, 2018, 1–10, 2018, <https://doi.org/10.1155/2018/5189761>
- [40] Rutkunas, V.; Gedrimiene, A.; Akulauskas, M.; Fehmer, V.; Sailer, I.; Jegelevicius, D.: In vitro and in vivo accuracy of full-arch digital implant impressions, *Clinical Oral Implants Research*, 32(12), 2021, 1444–1454, <https://doi.org/10.1111/clr.13844>
- [41] Strauß, P.; Mosch, R.; Sandmaier, M.; Von See, C.: Intraoral scanner accuracy: The influence of manual movement?, *Journal of Osseointegration*, 13(4), 2021, S285–S288, <https://doi.org/10.23805/JO.2021.13.S04.5>
- [42] Barenghi, L.; Barenghi, A.; Cadeo, C.; Di Blasio, A.: Innovation by Computer-Aided Design/Computer-Aided Manufacturing Technology: A Look at Infection Prevention in Dental Settings, *BioMed Research International*, 2019, 6092018, 2019, <https://doi.org/10.1155/2019/6092018>