



HAL
open science

Algorithms comparison for hydrogen storage predictive control on an islanded microgrid

Adrien Gauché, David Morin, Raphaël Chenouard, Malek Ghanes

► **To cite this version:**

Adrien Gauché, David Morin, Raphaël Chenouard, Malek Ghanes. Algorithms comparison for hydrogen storage predictive control on an islanded microgrid. IFAC World Congress 2023, IFAC, Jul 2023, Yokohama, Japan. pp.7966-7971, 10.1016/j.ifacol.2023.10.917 . hal-04250128

HAL Id: hal-04250128

<https://hal.science/hal-04250128v1>

Submitted on 23 Oct 2023

HAL is a multi-disciplinary open access archive for the deposit and dissemination of scientific research documents, whether they are published or not. The documents may come from teaching and research institutions in France or abroad, or from public or private research centers.

L'archive ouverte pluridisciplinaire **HAL**, est destinée au dépôt et à la diffusion de documents scientifiques de niveau recherche, publiés ou non, émanant des établissements d'enseignement et de recherche français ou étrangers, des laboratoires publics ou privés.



Distributed under a Creative Commons Attribution - NonCommercial - NoDerivatives 4.0 International License

Algorithms comparison for hydrogen storage predictive control on an islanded microgrid[★]

Adrien GAUCHÉ[✉]*,** David MORIN[✉]*
Raphaël CHENOUDARD[✉]** Malek GHANES**

* *S.A. PowiDian, F-37700 La Ville-aux-Dames, France (e-mail: david.morin@powidian.com)*

** *Nantes Université, École Centrale Nantes, CNRS, LS2N, UMR 6004, F-44000 Nantes, France, (e-mail: {adrien.gauche,raphael.chenouard,malek.ghanes}@ls2n.fr)*

Abstract: This paper presents a comparison of some classical metaheuristic (Particle Swarm Optimisation, Simulated Annealing) and deterministic (Branch & Bound, Pattern Search) algorithms for the optimization of the storage control of a microgrid over a whole year with real data. These algorithms are compared on the relevance of the controls in terms of energy autonomy, power losses and wear of the hydrogen chain as well as on the computational burden for a small embedded controller. This allows to highlight a type of algorithm adapted to a limited time and means of calculation that we find in real conditions. This study also points out the importance of prediction errors and their impacts when controlling real systems.

Keywords: Smart grids, Optimal operation and control of power systems, Predictive control, Energy management

1. INTRODUCTION

1.1 Context & motivation

By relying on renewable generations and storage instead of diesel generators, it is possible to supply loads while reducing logistics, operating costs and greenhouse gas emissions on islanded grids. A microgrid aggregates generations, storage and consumption in the same architecture. It allows gathering information and control to consider a unified management strategy Farhangi (2010); Olivares et al. (2014), this is smartgrid.

The main difficulty of islanding is autonomy and reliability. Renewable generation periods are decoupled from consumption periods with intermittency. Thanks to its high energy density, hydrogen is a promising energy vector for storage, but H₂ chain control remains under study Arsad et al. (2022). This is why an Energy Management System (EMS) provides a strategy to store energy Bukar and Tan (2019) while taking into account technical and economical objectives. Moreover, EMS framework, optimization techniques and computational approaches have impacts on efficient and reliable operations Salehi et al. (2022). In addition, a low computational burden to determine controls is required to provide commands in a reasonable time at lower power consumption.

1.2 Literature review

Raya-Armenta et al. (2021) produced a review on isolated microgrids and their control by EMS systems, outlining the landscape of the techniques, future trends and possible improvements. The definition of microgrid is discussed and authors explore 6 control aspects : constraints, time-frame, objective functions, frameworks, uncertainty and formulation. The key findings reside in the highlighting of new metaheuristics (e.g. Jaya) and outline of the future challenges to improve EMS: microgrids modelling, forecasting and learning, lower level controllers, decentralized EMS, communication and proof of concept.

Indeed, there are two main possibilities of optimization formulation: a full analytical mathematical definition (white box) or a partial definition based on Black Box Optimization (BBO) Boukouvala et al. (2016). With BBO, solvers improve local solutions without any insight about information in the black box (like derivatives), thus no global optimum guarantee can be provided Boukouvala et al. (2016). With white boxes, the analytical definition of the problem allows to use its mathematical properties to converge and prove the global optimality of the computed result Conn et al. (2009). Even non-linear behaviors (i.e. generation, unit commitment) can be expressed Kneeven et al. (2020). When dealing with the optimal control of complex systems, using a simulation model is often the preferred way to evaluate their behavior. Moreover, the BBO framework offers a flexible way to solve an optimization problem without eliciting the whole mathematical model, then it easily adapts to various microgrid structures.

* This work is supported by the National Association of Research and Technology (Association Nationale Recherche et Technologie) of France through the program CIFRE under grant 2020/0995.

Most recent works implement an EMS based on MPC, the most widespread management method Arsad et al. (2022). The EMS frameworks are often single-level, but they can be bi-level as in Ma et al. (2021), where the upper-level minimizes the overall cost, then the lower-level optimizes the storage operation strategy. We note that optimization problems are often economic or technical (operation cost, dumped energies, etc.). Usually uncertain values (solar irradiance, consumption) are forecasted and used as deterministic in MPC Morin et al. (2018, 2019), but some studies take into account more finely their randomness, e.g. IGTD Tostado-Véliz et al. (2022). Garrido et al. (2021) used a simulation model and then Reinforcement Learning to learn the best commands. The MPC remains better than the RL control when the horizon is correctly predicted, i.e. the prediction error is moderate. Here components considered for generation are solar panel (PV), Wind Turbine (WT) and Thermal Generators (TG), such as diesel engine and microturbine. Considered storage are Battery (BT) and H2 (hydrogen chain, at lease Hydrogen, ELectrolyzer EL or/and Fuel Cell FC). Some microgrids can be islanded Ma et al. (2021) or connected to another grid.

As inferred by numerous reviews Olivares et al. (2014), MPC remains the most discussed and the simplest predictive EMS to implement. Among BBO techniques, Raya-Armenta et al. (2021) concludes that metaheuristics are very promising to find the EMS efficient solutions. However, a large part of these studies compare metaheuristics between them, as well as their underlying improvements, but do not consider the use of more classical BBO methods (e.g. Pattern Search) Das et al. (2021). In addition, optimizers may not find the optimum, but a reasonable optimal solution. Then, the stochastic aspect of metaheuristics leads to different results (even slightly) at each execution and a larger number of cost function evaluations, thus to a higher consumption of computational resources.

Morin et al. (2018, 2019) have proposed a binary formulation of the decision tree to get EL and FC Unit Commitment (UC) in an islanded microgrid (Figure 1). The horizon's best path is determined first by a greedy algorithm, then by a Branch & Bound (BB). Compared to myopic control, MPC improves the grid exploitation by increasing energy storage, decreasing power losses and storage degradation (BT, EL, FC). These benefits mainly come from the objective function that aggregate such criteria in a single function. However, evaluated commands are binary (On/Off), leading to a large part of the possible solutions' space not being explored, and thus having potential for improvements. In addition, BB hardly scales on embedded systems when increasing the number of decisions variables (related to equipment quantity, time step and horizon) due to its exponential algorithm complexity.

1.3 Contributions

In this work, we implemented the same microgrid as in Morin et al. (2019), but investigating an extended formulation with different solvers. Previous publications tend to consider separately metaheuristics or deterministic methods for MPC solving.

This paper focuses on comparing some state of the art BBOs to control a microgrid using a whole year simulation based on a real dataset. We selected BBOs from different categories: stochastic (population-based and single point) and deterministic. Several criteria are used to compare their performances and their impact on the microgrid behavior.

The problem and its black-box formulation are presented in section 2. The section 3 details the experiments with a discussion about the results, before the conclusion in section 4.

2. PROBLEM FORMULATION

2.1 Microgrid description

The microgrid case study is depicted in Figure 1. It includes a PV (solar) generation \widehat{P}_{PV} (kW), a load consumption \widehat{P}_L (kW), a BT (battery) with P_{BT} (kW) power in and out for storage, H2 chain with EL (electrolyzer) power consumption P_{EL} (kW) to produce H2, HT (hydrogen tank) power-to-gas energy storage under p_{H2} (bar) pressure and FC (Fuel Cell) power generation P_{FC} (kW) by consuming H2. The power balance in the bus is (1).

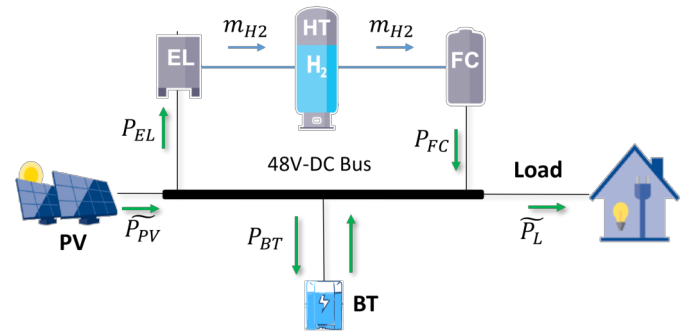

Fig. 1. Microgrid schematic Morin et al. (2019)

$$P_{PV} + P_{FC} + P_{BT} - P_L - P_{EL} = 0 \quad (1)$$

The controllable equipments are EL and FC, i.e., represented by P_{FC} and P_{EL} variables. The model use intermediary variables, namely the State Of Charge (SOC) of BT (between 0 and 1) and the pressure (p_{H2}) in HT (bars). These variables define the state S over the time horizon and t_0 defines the initial state. Uncertain parameters are represented by their expected values with $\widehat{\cdot}$: \widehat{P}_{PV} and \widehat{P}_L .

$$S = \begin{pmatrix} SOC(t_0), \dots, SOC(t_N) \\ p_{H2}(t_0), \dots, p_{H2}(t_N) \end{pmatrix} \quad (2)$$

The energy storage over the horizon (characterized by $S(t)$: $SOC(t), p_{H2}(t)$) is calculated in a simulation model (i.e. the black box) by recurrence according to the initial state and a power balance based on incoming power (P_{EL} , $P_{BT}^+(t)$), outgoing power (P_{FC} , $P_{BT}^-(t)$) and energy losses in the microgrid Dahmane et al. (2019).

2.2 Model Predictive Control (MPC)

In this paper, the MPC is implemented as in Figure 2, expected values \widehat{W} (irradiance, temperature and load)

are forecasted by a Wavelet Neural Network Morin et al. (2019) in the *Predictions* block. Then, from the applied control V and input \widehat{W} , the *Simulation model* block computes the state S (stored energies) and power flows of the microgrid for the whole horizon (N). The *Optimizer* block uses the *Simulation model* to seek an optimal vector V^* that maximizes the cost function evaluation (see Equation (5)) under constraints (see Equation (4)).

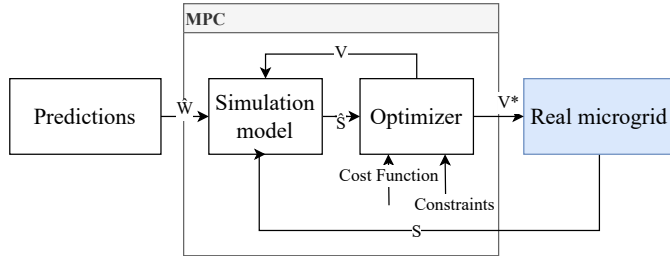

Fig. 2. Predictive control Camacho and Bordons (2007)

Decision variables for the EL and FC take their values between 500W and 2500W (equipment On) or 0 (equipment Off). These constraints force remaining in a zone where the electricity / H2 conversion coefficient is assumed constant. The control vector V is defined over the optimization horizon N , as detailed in Equation (3):

$$V = \begin{pmatrix} P_{EL}(t_1), \dots, P_{EL}(t_N) \\ P_{FC}(t_1), \dots, P_{FC}(t_N) \end{pmatrix} \quad (3)$$

Two types of constraints are considered to restrict the admissible commands. The logical ones forbid EL and FC to be active on the same slot t_i . Then, the technical constraints apply minimal and maximal thresholds for SOC and p_{H2} as in Equation (4), from (2) and Fig. 2:

$$\begin{pmatrix} 0.2 \\ 0.8 \end{pmatrix} \leq \begin{pmatrix} SOC(t_i) \\ p_{H2}(t_i) \end{pmatrix} \leq \begin{pmatrix} 1 \\ 38 \end{pmatrix}, \forall i \in \{1, \dots, N\} \quad (4)$$

The *objective function* is defined as an aggregation of several criteria, as in Morin et al. (2019, 2018). It can be formulated as a sum of transition functions C_j between states with coefficient α_j for criterion j :

$$\max_{V \in A} \sum_{j=1}^3 \sum_{i=1}^N \alpha_j C_j(V(t_i), S(t_i), \mathbb{E}(\widehat{W}(t_i))) \quad (5)$$

Criterion C_1 relates to power flows while satisfying the load, avoiding low BT and HT states, and PV energy not being stored. C_2 aims at reducing power losses in converters and storage (BT, H2 chain), thus enhancing the efficiency of the microgrid. Finally, C_3 takes into account premature aging of equipments.

2.3 Model data

The studied microgrid corresponds to an isolated microgrid in Col du Palet (refuge in mountains) with 4.8kW of peak PV generation, BT of 14.8kWh, 7.5kg of H2 capacity in HT (30 bars 2.5m³), EL and FC of 2.5kW. From \widehat{W} , we obtain the delta between generation and consumption, the power flow in the bus without any control. Figure 3 is an example of three days in October, we observe power

consumption during the night around $-0.5kW$ and PV generation during the day reaching 4kW with some drops in production depending on the weather. The simulation uses a one-year dataset from April 1, 2018 to March 31, 2019, with mean power of 0.32kW, median of $-0.39kW$, maximum power of 4.4kW and minimum of $-3.5kW$.

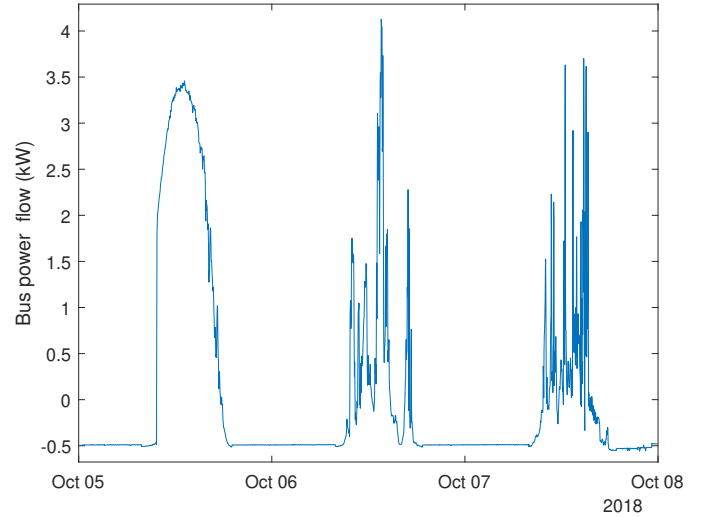

Fig. 3. Power flow ($P_{PV} - P_L$) in the electrical bus

3. EXPERIMENTS

3.1 Solvers

A few representative Derivative Free Optimization (DFO) solvers are selected to investigate their global behavior applied to our context. A Particle Swarm Optimization (PSO) represent the behavior of population-based algorithms and a Simulated Annealing (SA) the path algorithms for metaheuristics. A Pattern Search (PS) algorithm represents deterministic DFO algorithms. SA and PS are initialized with a zero vector as a good initial guess in most cases. These optimizers are taken from the Global Optimization Toolbox of Matlab (Release 2021b) ¹. To generalize the optimization over a whole year, we do not consider a fine-tuning adapted to a specific horizon, we use the recommended default settings. As an example, all optimizers use the same FunctionTolerance parameter (10^{-6}). We compare the results with the original Branch-and-Bound from Morin et al. (2018). We configure the simulation to optimize the orders on a sliding horizon of 12 hours with a time step of 0.5 hour ($N=24$). Experiments are run on a laptop with i7-11850H on 1 thread and 16 GB of memory.

3.2 Typical command

Figure 4 shows EL (full bar) and FC (dashed bar) commands obtained from the optimal vector for a scenario of 12 hours. The net power P_{net} (red line) defines the power balance between the load and the PV generation. We can see that the H2 chain is switched off most of the time. The FC is only active for 2 consecutive slots in the night due to the SOC lower limit constraint. The battery continues

¹ <https://fr.mathworks.com/help/gads/>, consulted on September 2021

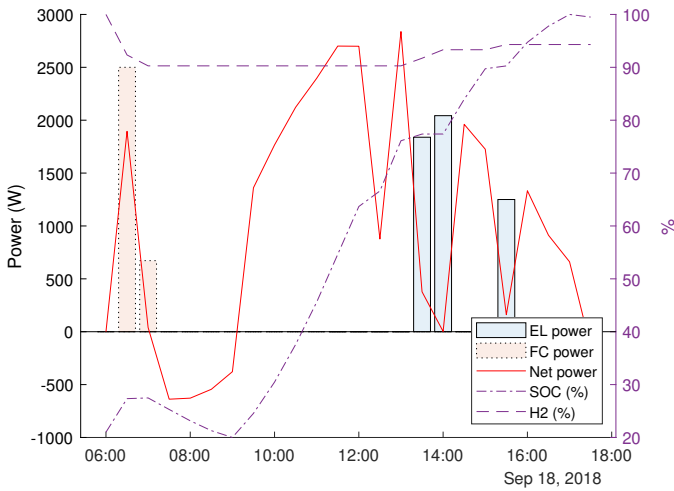

Fig. 4. Example of command optimization

to discharge until 09:00 AM while the PV generation is not high enough. Then, P_{net} is positive and the SOC of BT increase close to 70% until around 01:00 PM. The EL is then activated for 1 hour to store the excess energy in HT, it is activated a second time at 3:30 PM for the same reason. This figure is a typical example of the control produced by a continuous solver for the EL and the FC.

3.3 Optimization results

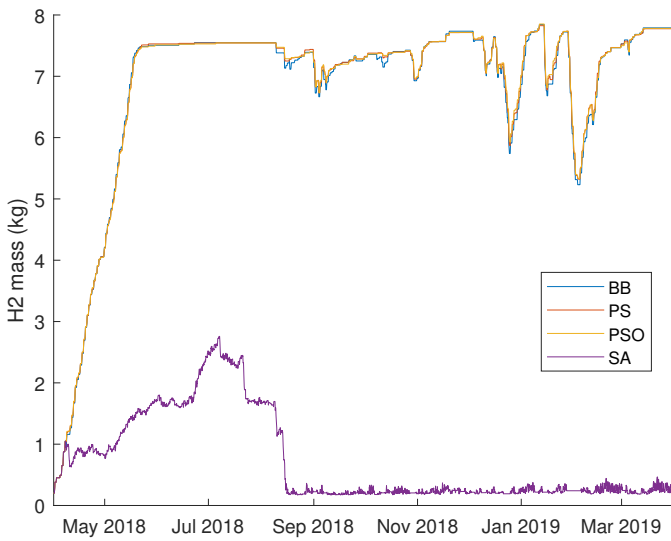

Fig. 5. H2 mass in the tank

Each one year simulation takes more than 24 hours to compute. From Figure 5, in terms of mass of H2 stored, none of the BB, PS, PSO stand out. We notice that H2 is mainly used in January and February, when the generation is the lowest and the battery is more difficult to recharge. For the SA, it fails to provide a consistent command to fill the tank.

In the Table 1, we find the median, mean and minimum values of stored energy over one year of simulation with the 4 algorithms. The differences in the median, mean and minimum of SOC and H2 mass between BB, PS and PSO are about 1%. SA in its default configuration is not able

Table 1. Energy storage over 1 year

	BB	PS	PSO	SA
Median SOC (%)	76.0	77.6	77.5	64.4
Mean SOC (%)	74.0	74.1	73.9	60.4
Min SOC (%)	13.8	13.4	12.4	0
Median H2 (kg)	7.404	7.430	7.420	0.264
Mean H2 (kg)	6.838	6.858	6.860	0.720
Min H2 (kg)	0.201	0.201	0.201	0.170

to find the most efficient solutions with the diversity of scenarii in a whole year.

Table 2. EL and FC activation

	BB	PS	PSO	SA
EL median (kW)	2.5	1.875	2.496	1.325
EL mean (kW)	2.5	1.777	2.116	1.397
EL on (h)	405	519	430	2102
EL starts	237	309	289	1457
FC median (kW)	2.5	0.624	0.858	0.787
FC mean (kW)	2.5	1.047	1.047	0.898
FC on (h)	58	98	90	494
FC starts	93	111	124	834

The Table 2 shows the power control characteristics of the H2 chain (EL and FC) as well as the activation time and the number of starts. The BB switches the EL and FC the shortest with the fewest start-stop cycles. This is due to the binary resolution of the problem that results in consuming/delivering all energy at once, EL and FC started less often and for a shorter time for the same amount of energy. The PSO is the second algorithm and the PS the third to put less strain on the H2 chain.

Table 3. Electrical losses

	BB	PS	PSO	SA
Median (kW)	0.381	0.362	0.360	1.233
Mean (kW)	0.407	0.388	0.385	1.220
Sum (kWh)	3569	3406	3374	10693

On Table 3 the electrical losses summed over the year with the PS and PSO algorithms are very close (around 1%). The BB does worse with 6% more losses. With SA, the cumulative losses are the highest of the benchmark, as are the average and median losses (over 1 kW).

Table 4. Optimizers output cost function evaluation

	BB	PS	PSO	SA
Median evaluation	-8.01	-5.65	-5.65	-46.6
Mean evaluation	-16.2	-8.89	-9.20	-48.5
Worst evaluation	-105.2	-90.7	-100.9	-191.7

The Table 4 summarizes the evaluations of the objective function at the output of the optimizer, when it has converged. As this is a maximization of the objective function, the higher the score, the more efficient the optimization. The PS and PSO are the best, equal from the median, but in average value the PS does slightly better (4%). The worst evaluation found by the PS is 10% below that found by the PSO. According to the median, the BB finds less efficient solution (41% worse) than PS and PSO.

In the Figure 6, we display the sum of the objective function values for all best solutions proposed by the optimizers, but evaluated with the real data and not the predictions. We do not display SA because the result

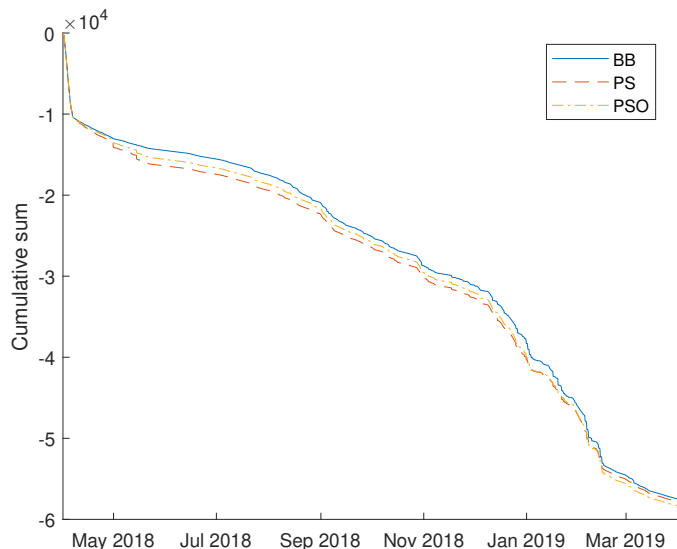

Fig. 6. Cumulative sum of objective function values from each simulation step

is not relevant. BB, PS and PSO provide very close results. BB is slightly better because it provides all-or-nothing commands, and the cost sub-function representing wear and tear provides a lower value. The PS and PSO commands can be disadvantaged because they are very optimized, therefore much more sensitive to deviations between predictions and realizations.

The Figure 7 summarize the number of evaluations of the objective function. The lower the number of evaluations is, the fewer iterations the algorithm needs to converge to the optimal value. According to the median value, the BB often converge quickly, due to cases where no decision is made (H2 chain off). Compared to the BB, the PS and the PSO need respectively twice and a thousand times more evaluations to converge. On the other hand, on average, the PSO has the fewest evaluations, followed by BB and PS. BB is the best in terms of worst number of evaluations, followed by PS and PSO (twice).

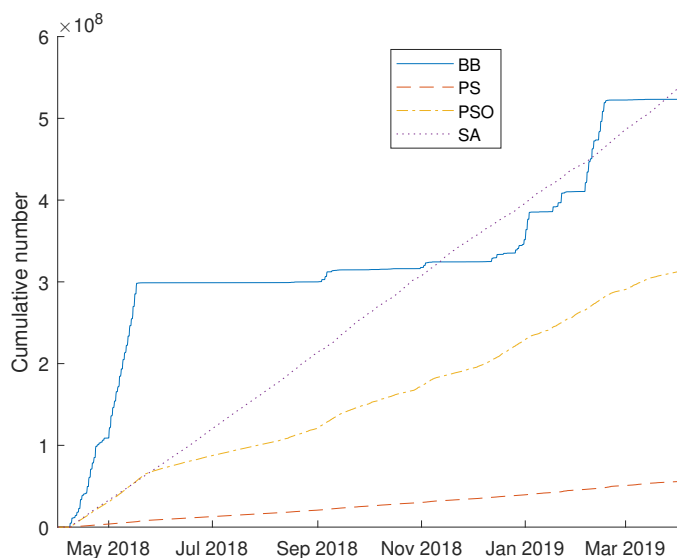

Fig. 7. Cumulative number of objective function evaluations

3.4 Discussions and improvements

We do not observe any significant difference between the PS, PSO and BB according to the predictive controls provided (see Figure 5 and Figure 6). For energy management in this case study, metaheuristics do not seem to be more suitable than deterministic methods. In detail, we notice that the BB is slightly better on wear, the PS on storage and the PSO on power losses. This can be due to the ability of the BB to decrease the number of activations by the binary commitment, the PSO to explore the search space to minimize losses, and the PS to search around the initial zero vector of low operating points (local search). To prioritize the objectives differently, the weighting can be changed.

About the objective function optimization, the PS is very slightly the best (see Table 4). Moreover, the PS is by far the least greedy in terms of calculation (see Figure 7). The stopping criteria of the metaheuristics could be better set, but the gap with PS is important and may not be filled with a slight improvement on this aspect. Furthermore, a large part of the criteria were common between the PS and the meta heuristics (default setting of the MATLAB toolbox). All optimizers returned the same exit flag (1) on all optimizations, i.e. the objective function cannot be improved with a tolerance greater than 10^{-6} . Obviously, a dedicating tuning for each algorithm should provide better results, as for the SA which fails to find an efficient solution at several steps of the simulation. This tuning step is a drawback of most metaheuristics and the tuning may not fit all the diverse cases encountered in the whole activity period of a microgrid.

Beyond the optimization capacities and computational burden of each algorithm, we notice in Figure 6 that a perfectly optimized control on a predicted horizon may not be the optimal solution in real life. For instance, random events can occur, like cloud crossing at 12 a.m. (see Figure 4). The impact of these random events should be integrated in the optimization to provide a more relevant control. Probabilistic models can be used instead of fixed predicted values as in Knueven et al. (2020). Another approach is to use robust optimization to get solutions with guarantees on performances for uncertainty intervals for these parameters Stein (2012). The main issue is to be able to keep a light computing burden as such algorithms have to be embedded in the microgrid controller. Moreover, some modeling parameters like the number of considered steps in the horizon can be adapted to keep the computation as light as possible, but it will impact the ability of the optimizer to anticipate events.

4. CONCLUSION

To control a hydrogen chain (Electrolyser and the Fuel Cell) of a hybrid storage on an islanded microgrid, one MPC must provide a command in a reasonable time with limited computing resources. A Black Box formulation is used to have a finer simulation rather than White Box. Then, a comparison of different types of optimizers to solve the MPC has been performed with Branch & Bound (BB), Pattern Search (PS), Particle Swarm Optimization (PSO) and Simulated Annealing (SA).

The PS can be considered as the best candidate for this application. In this case study, we do not notice any major difference on the relevance of the commands between the different algorithms over a whole year of simulation. But the metaheuristics perform many more calculations to find similar results than the deterministic algorithms. We also notice that a perfectly optimized control on a predicted horizon is not necessarily relevant when considering the prediction errors with reality.

Improvements can be done in a better tuning of this algorithm, especially concerning the initialization of the start vector. Further investigations can be necessary to make comparisons between such BBO and using a simplified analytical model. The tradeoff is between computing the exact solution of a simplified model or finding a good solution to a *real* system Conn et al. (2009); Knueven et al. (2020). This analysis should also focus on the computation burden and the quality of solutions, with their impact on a whole year scenario. Finally, a probabilistic formulation of the model can be considered to take into account more precisely the stochastic aspect of generation and consumption, in order to make the control more resilient to unforeseen.

REFERENCES

- Arsad, A.Z., Hannan, M., Al-Shetwi, A.Q., Mansur, M., Muttaqi, K., Dong, Z., and Blaabjerg, F. (2022). Hydrogen energy storage integrated hybrid renewable energy systems: A review analysis for future research directions. *International Journal of Hydrogen Energy*, S0360319922013374. doi:10.1016/j.ijhydene.2022.03.208.
- Boukouvola, F., Misener, R., and Floudas, C.A. (2016). Global optimization advances in Mixed-Integer Nonlinear Programming, MINLP, and Constrained Derivative-Free Optimization, CDFO. *European Journal of Operational Research*, 252(3), 701–727. doi:10.1016/j.ejor.2015.12.018.
- Bukar, A.L. and Tan, C.W. (2019). A review on stand-alone photovoltaic-wind energy system with fuel cell: System optimization and energy management strategy. *Journal of Cleaner Production*, 221, 73–88. doi:10.1016/j.jclepro.2019.02.228.
- Camacho, E.F. and Bordons, C. (2007). *Model Predictive Control*. Advanced Textbooks in Control and Signal Processing. Springer London, London. doi:10.1007/978-0-85729-398-5.
- Conn, A.R., Scheinberg, K., and Vicente, L.N. (2009). *Introduction to Derivative-Free Optimization*. Society for Industrial and Applied Mathematics. doi:10.1137/1.9780898718768.
- Dahmane, Y., Ghanes, M., Chenouard, R., and Alvarado-Ruiz, M. (2019). Decentralized Control of Electric Vehicle Smart Charging for Cost Minimization Considering Temperature and Battery Health. In *2019 IEEE International Conference on Communications, Control, and Computing Technologies for Smart Grids (SmartGridComm)*, 1–6. IEEE, Beijing, China. doi:10.1109/SmartGridComm.2019.8909796.
- Das, G., De, M., and Mandal, K. (2021). Multi-objective optimization of hybrid renewable energy system by using novel autonomic soft computing techniques. *Computers & Electrical Engineering*, 94, 107350. doi:10.1016/j.compeleceng.2021.107350.
- Farhangi, H. (2010). The path of the smart grid. *IEEE Power and Energy Mag.*, 8(1), 18–28. doi:10.1109/MPE.2009.934876.
- Garrido, C., Marin, L.G., Jimenez-Estevéz, G., Lozano, F., and Higuera, C. (2021). Energy Management System for Microgrids based on Deep Reinforcement Learning. In *2021 IEEE CHILEAN Conference on Electrical, Electronics Engineering, Information and Communication Technologies (CHILECON)*, 1–7. IEEE, Valparaíso, Chile. doi:10.1109/CHILECON54041.2021.9703072.
- Knueven, B., Ostrowski, J., and Watson, J.P. (2020). On Mixed-Integer Programming Formulations for the Unit Commitment Problem. *INFORMS Journal on Computing*, ijoc.2019.0944. doi:10.1287/ijoc.2019.0944.
- Ma, L., Sui, K., Liang, Y., Qiu, J., Cheng, X., Shang, L., and Dong, X. (2021). A bi-level optimal configuration model of isolated microgrid considering energy storage lifetime. In *2021 International Conference on Power System Technology (POWERCON)*, 1084–1088. IEEE, Haikou, China. doi:10.1109/POWERCON53785.2021.9697602.
- Morin, D., Stevenin, Y., and Brault, P. (2019). Energy Management of isolated DC microgrids with hybrid batteries-hydrogen storage system using Model Predictive Control and Wavelet Neural Networks based forecasts. In *2019 21st European Conference on Power Electronics and Applications (EPE '19 ECCE Europe)*, P.1–P.10. IEEE, Genova, Italy. doi:10.23919/EPE.2019.8915136.
- Morin, D., Stevenin, Y., Grolleau, C., and Brault, P. (2018). Evaluation of performance improvement by model predictive control in a renewable energy system with hydrogen storage. *International Journal of Hydrogen Energy*, 43(45), 21017–21029. doi:10.1016/j.ijhydene.2018.09.118.
- Olivares, D.E., Mehrizi-Sani, A., Etemadi, A.H., Canizares, C.A., Iravani, R., Kazerani, M., Hajimiragha, A.H., Gomis-Bellmunt, O., Saeedifard, M., Palma-Behnke, R., Jimenez-Estevéz, G.A., and Hatziargyriou, N.D. (2014). Trends in Microgrid Control. *IEEE Trans. Smart Grid*, 5(4), 1905–1919. doi:10.1109/TSG.2013.2295514.
- Raya-Armenta, J.M., Bazmohammadi, N., Avina-Cervantes, J.G., Sáez, D., Vasquez, J.C., and Guerrero, J.M. (2021). Energy management system optimization in islanded microgrids: An overview and future trends. *Renewable and Sustainable Energy Reviews*, 149, 111327. doi:10.1016/j.rser.2021.111327.
- Salehi, N., Martinez-Garcia, H., Velasco-Quesada, G., and Guerrero, J.M. (2022). A Comprehensive Review of Control Strategies and Optimization Methods for Individual and Community Microgrids. *IEEE Access*, 1–1. doi:10.1109/ACCESS.2022.3142810.
- Stein, O. (2012). How to solve a semi-infinite optimization problem. *European Journal of Operational Research*, 223(2), 312–320. doi:10.1016/j.ejor.2012.06.009.
- Tostado-Véliz, M., Kamel, S., Hasanién, H.M., Turky, R.A., and Jurado, F. (2022). Uncertainty-aware day-ahead scheduling of microgrids considering response fatigue: An IGDT approach. *Applied Energy*, 310, 118611. doi:10.1016/j.apenergy.2022.118611.