



**HAL**  
open science

# Asymptotic modeling of the transient response of nonlinear Kelvin-Voigt viscoelastic thin plates with Norton or Tresca friction by Trotter theory

Yotsawat Terapabkajornded, Somsak Orankitjaroen, Christian Licht, Thibaut Weller

## ► To cite this version:

Yotsawat Terapabkajornded, Somsak Orankitjaroen, Christian Licht, Thibaut Weller. Asymptotic modeling of the transient response of nonlinear Kelvin-Voigt viscoelastic thin plates with Norton or Tresca friction by Trotter theory. *Applications of Mathematics*, 2023, pp.1-24. 10.21136/AM.2023.0013-23 . hal-04239227

**HAL Id: hal-04239227**

**<https://hal.science/hal-04239227>**

Submitted on 12 Oct 2023

**HAL** is a multi-disciplinary open access archive for the deposit and dissemination of scientific research documents, whether they are published or not. The documents may come from teaching and research institutions in France or abroad, or from public or private research centers.

L'archive ouverte pluridisciplinaire **HAL**, est destinée au dépôt et à la diffusion de documents scientifiques de niveau recherche, publiés ou non, émanant des établissements d'enseignement et de recherche français ou étrangers, des laboratoires publics ou privés.

ASYMPTOTIC MODELING OF THE TRANSIENT RESPONSE  
OF NONLINEAR KELVIN-VOIGT VISCOELASTIC THIN PLATES  
WITH NORTON OR TRESCA FRICTION BY TROTTER THEORY

YOTSAWAT TERAPABKAJORNDED, SOMSAK ORANKITJAROEN, Bangkok,  
CHRISTIAN LICHT, Bangkok, THIBAUT WELLER, Montpellier

*Abstract.* We study the dynamic response of a thin viscoelastic plate made of a nonlinear Kelvin-Voigt material in bilateral contact with a rigid body along a part of its lateral boundary with Norton or Tresca friction. We opt for a direct use of the Trotter theory of convergence of semi-groups of operators acting on variable spaces. Depending on the various relative behaviors of the physical and geometrical data of the problem, the asymptotic analysis of its unique solution leads to different limit models whose properties are detailed. We highlight the appearance of an additional state variable that allows us to write these limit systems of equations in the same form as the genuine problem.

*Keywords:* thin viscoelastic plate; Norton or Tresca friction; transient problem; multivalued operator; nonlinear semigroup of operators; Trotter's theory of convergence of semi-groups

*MSC 2020:* 74-10

## 1. INTRODUCTION

This study concerns the dynamic response, in the framework of small strains, of a thin plate made of a viscoelastic material of nonlinear Kelvin-Voigt type in bilateral contact with a rigid body along a part of its lateral boundary with Norton or Tresca friction subjected to a given load. One can find in [12] an example of a study dedicated to the analysis of a frictional contact problem for viscoelastic materials but, to the best of our knowledge, we are not aware of a rigorous mathematical approach to the asymptotic mathematical modeling of such a situation in the case of thin structures. In the recent past we have carried out the asymptotic analysis of the quasi-static response of a linearly viscoelastic plate of Kelvin-Voigt type [14]

before addressing the case of the transient response of a thin linearly elastic plate with Norton or Tresca friction [7]. Our goal here is to study the more complex problem blending together (1) the asymptotic mathematical modeling of thin plates, (2) the viscoelasticity of Kelvin-Voigt and (3) the Norton or Tresca friction in (4) a dynamical context. But our purpose is to do so in a direct way, in the sense that we propose to bypass the classical step of scaling the genuine physical problem. This is made possible by a suitable nonlinear extension [8] of Trotter's theory of convergence of semi-groups of linear operators acting on variable spaces [15]. This theory is particularly well suited to the mathematical modeling in physics of continuous media (see [10]), particularly because almost all boundary value problems stemming from physics are *parameterized* by the domain where the problem is posed and/or by the physical coefficients which may be very high, very low or strongly oscillating. Briefly and roughly, the framework of this theory is as follows. On the one hand, we have a sequence of evolution equations involving a parameter  $s$  taking its values in a countable set  $\mathcal{S}$  with a single cluster point  $\bar{s}$  and conveying the physical information that need to be taken into account:

$$(1.1) \quad (\mathcal{P}^s) \quad \begin{cases} \frac{du^s}{dt} + A^s u^s \ni f^s & \text{in } \mathcal{H}^s, \\ u^s(0) = u^{s0}. \end{cases}$$

It is set in a sequence of Hilbert spaces  $\mathcal{H}^s$  with norm  $|\cdot|^s$ , governed by a sequence of maximal-monotone operators  $A^s$  with domains  $D(A^s)$  and with reasonable data leading to a sufficiently smooth unique solution to  $(\mathcal{P}^s)$ . On the other hand, we have to uncover another evolution equation

$$(1.2) \quad (\mathcal{P}) \quad \begin{cases} \frac{du}{dt} + Au \ni f & \text{in } \mathcal{H}, \\ u(0) = u^0, \end{cases}$$

set in a Hilbert space  $\mathcal{H}$  with norm  $|\cdot|$ , governed by a maximal-monotone operator  $A$  with domain  $D(A)$  and with data  $u^0$  and  $f$  which lead to a sufficiently smooth unique solution to  $(\mathcal{P})$ . It is critical to note that the nature of the spaces  $\mathcal{H}^s$  and  $\mathcal{H}$  may be very different, but the requirements of rigorous mathematical modeling make it mandatory that the sequence of spaces  $\mathcal{H}^s$  approaches/converges to  $\mathcal{H}$ ! We call this "convergence in the sense of Trotter". It implies an operator from  $\mathcal{H}$  to  $\mathcal{H}^s$  denoted by  $P^s$  which to a certain extent makes it possible to compare an element of  $\mathcal{H}$  with an element of  $\mathcal{H}^s$ . More precisely, it allows to associate a suitable *representative*  $P^s u$  in  $\mathcal{H}^s$  with any  $u$  in  $\mathcal{H}$ . This operator  $P^s$  has to satisfy two conditions of (a) uniform continuity and (b) good energetic representation:

- (a) there exists  $C > 0$  such that  $|P^s u|^s \leq C|u|$  for all  $u \in \mathcal{H}$  for all  $s \in \mathcal{S}$ ,
- (b)  $\lim_{s \rightarrow \bar{s}} |P^s u|^s = |u|$  for all  $u \in \mathcal{H}$ .

Then the notion of comparison which defines the Trotter convergence of a sequence may be introduced:

**Definition 1.1.** A sequence  $(u^s)_{s \in \mathcal{S}}$  in  $\mathcal{H}^s$  converges in the sense of Trotter towards an element  $u$  of  $\mathcal{H}$  if and only if

$$\lim_{s \rightarrow \bar{s}} |P^s u - u^s|^s = 0.$$

Finally (see [8], [15]), the result of convergence of the solution to  $(\mathcal{P}^s)$  towards the one to  $(\mathcal{P})$  may be characterized as follows:

**Theorem 1.1.** *Let  $u, u^s$  be the strong solutions to  $(\mathcal{P})$  and  $(\mathcal{P}^s)$ . If*

- (i)  $|P^s u^0 - u^{s0}|^s \rightarrow 0,$
  - (ii)  $\int_0^T |P^s f(t) - f^s(t)|^s dt \rightarrow 0,$
  - (iii) *for all  $y \in X$ , dense in  $\mathcal{H}$ ,  $|P^s(\mathbb{1} + A)^{-1}y - (\mathbb{1} + A^s)^{-1}P^s y|^s \rightarrow 0,$*
- then, uniformly on  $[0, T]$ ,  $|P^s u(t) - u^s(t)|^s \rightarrow 0$  and  $|u^s(t)|^s \rightarrow |u(t)|.$*

The first two conditions concern the data (initial states and right-hand sides) of the problems, the last one ( $\mathbb{1}$  stands for the identity operator) deals with the resolvents of operators  $A^s$  and  $A$ . The resolvents can in general be associated with the solution to the corresponding steady state problem. Therefore, roughly speaking, when one knows how to address the convergence in the steady state version of the transient problem, one knows how to deal with the convergence in the genuine transient problem. This mostly implies very short proofs limited to the implementation of Trotter's theory: guess  $\mathcal{H}$  or  $\mathcal{H}^s$  and construct  $P^s$  satisfying (a) and (b) as Trotter's convergence of the resolvents is relatively easy to infer.

As the reader will have realized, it is true that this method requires the introduction of an open fixed set  $\Omega$ . However problem  $(\mathcal{P})$  is not a scaled version of  $(\mathcal{P}^s)$ . The convergence in the sense of Trotter of the unique solution  $u^s$  to the genuine physical problem  $(\mathcal{P}^s)$  posed over the domain  $\Omega^\varepsilon$  of the real plate<sup>1</sup> to the unique solution  $u$  to the abstract problem  $(\mathcal{P})$  posed over the abstract fixed open set  $\Omega$  is none other than *the convergence to zero of the relative energy gap directly computed on  $\Omega^\varepsilon$  between the real physical state (here  $u^s(t)$ ) which solves the genuine physical problem  $(\mathcal{P}^s)$  and an "equivalent" state (in this case  $P^s u(t)$ ) defined on the real domain  $\Omega^\varepsilon$  and obtained from the solution  $u(t)$  to the abstract problem  $(\mathcal{P})$  through the operator  $P^s$ .*

Both in terms of dimension reduction and periodic homogenization, one of the features of viscoelastic Kelvin-Voigt solids, when it comes to asymptotic analysis, is the appearance of a delayed memory term in the limit model (see [5], [9] for example).

---

<sup>1</sup> Classically  $\varepsilon$  denotes half the thickness of the plate and is a component of the parameter  $s$ .

Because the limit model is no longer of Kelvin-Voigt type, such a situation has been interpreted as an example “of a sequence of semi-groups whose limit is not a semi-group” and that may lead the reader to think that the framework presented here does not work. The profound insight developed in [16] helped us to overcome this interpretation by introducing an additional state variable. In doing so, the sequence of operators  $A^s$ , which is noncompact in the sense of the usual convergence of the resolvent, becomes compact when we use an adaptation of the two-scale convergence in the case of dimension reduction (we call it “3d-2d” convergence). In doing so, we are led to believe that while little known, Trotter’s theory offers models with a more comprehensive view and is particularly well suited to the asymptotic mathematical modeling of a variety of problems that arise in the field of mechanics as mentioned in [10], but also in biology (see [2], [16] for example).

In Section 2 we set the problem in its variational and strong forms. It is made clear that in this physical situation, the parameter that appears in (1.1) is in fact a quadruplet  $s := (\varepsilon, \varrho, \mu, b)$  respectively composed of the thickness of the plate, its density and two “viscosity” coefficients related to Tresca or Norton friction and the density of the viscous pseudo-potential. This variational problem is denoted by  $(P^s)$ .

In Section 3 we prove that  $(P^s)$  has a unique solution consisting of a couple  $U^s := (u^s, v^s)$  living in a Hilbert space  $\mathcal{H}^s$ , where  $u^s$  and  $v^s$  respectively denote the displacement and the velocity fields. To this end,  $(P^s)$  is transformed into a differential inclusion  $(\mathcal{P}^s)$  of kind (1.1) by the help of a multi-valued maximal-monotone operator  $A^s$  whose definition is introduced.

In Section 4 the asymptotic behavior of  $U^s$  when the parameter  $s$  goes to its natural limit is studied. As largely explained *supra*, this stage implies the construction of Trotter’s theory framework whose technical structure is detailed. It is shown that depending on the relative magnitudes of the density, thickness and viscosity, twelve different cases must be taken into account. We therefore introduce a triplet  $I = (I_1, I_2, I_3) \in \{1, 2\} \times \{1, 2, 3\} \times \{1, 2\}$  which will be used as an index thereafter. In particular, the abstract problem is denoted by  $(P^I)$  (compare with (1.2)). We introduce a Hilbert space  $\mathcal{H}^I$  whose norm is  $|\cdot|^I$  and an operator  $P^{sI}$  which allows to compare the elements of  $\mathcal{H}^s$  to those of  $\mathcal{H}^I$ . The maximal-monotone operator that governs the differential inclusion  $(P^I)$  is denoted by  $A^I$ . Properties (a) and (b) together with a theorem of convergence are proved and their mechanical interpretation is provided. One of the tools used in this section is called “3d-2d convergence” and is presented in Appendix. As two-scale convergence did in the case of periodic homogenization, this tool naturally involves an additional displacement field which permits to keep the genuine structure (evolution equation/differential inclusion in a Hilbert space) for the limit problem. We insist on the fact that the nature of the limit space  $\mathcal{H}^I$  is completely different from the one of  $\mathcal{H}^s$  and involves functional

spaces defined on an abstract domain  $\Omega$ . Moreover and classically, any element of  $\mathcal{H}^s$  is a couple  $(u, v)$  of the kind (displacement, velocity), whereas any element of  $\mathcal{H}^I$  is admittedly of the same kind *but* with a modified “displacement component” constructed with an additional term (i.e. a hidden or internal state variable comes into play) and on the other hand the “velocity component” may involve only specific components of the time derivative of the usual displacement.

Eventually, Section 5 is devoted to the presentation of our seven different models and some conclusive remarks that underline their properties. We highlight the fact that the limit behavior is of the same type as the one of the genuine plate but *with an additional state variable*. The dynamical, quasi-static (possibly static) and frozen nature of the transverse and in-plane components of the displacement are detailed according to the different relative magnitudes of the physical coefficients. As already stated, it allows us to provide a simplified but accurate enough model through a convergence to zero of a relative energy gap. As explained in Remark 5.2, a crucial consequence is that while the limit displacement field which solves the “abstract limit” problem ( $\mathcal{P}^I$ ) is of Kirchhoff-Love type, the strain of the real genuine displacement field solving ( $\mathcal{P}^s$ ) is not close to the one of a Kirchhoff-Love (or even a Reissner-Mindlin) displacement field. Lastly, these “limit equations” are fairly easy to implement numerically.

## 2. PROBLEM SETTING

As is customary, we do not distinguish between  $\mathbb{R}^3$  and the Euclidean physical space whose orthonormal basis is denoted by  $\{e_1, e_2, e_3\}$ . For all  $\xi = (\xi_1, \xi_2, \xi_3)$  in  $\mathbb{R}^3$ , we write  $\widehat{\xi}$  for  $(\xi_1, \xi_2)$ . Throughout the paper, the Latin indices run over  $\{1, 2, 3\}$  while the Greek ones run over  $\{1, 2\}$ . Like  $\mathbb{R}^3$  and  $\mathbb{R}^2$ , the space  $\mathbb{S}^3$  of symmetric matrices of order 3 is endowed with the usual inner product and norm denoted by  $\cdot$  and  $|\cdot|$ . For each  $\kappa$  in  $\mathbb{S}^3$ , we define  $\widehat{\kappa}$  and  $\kappa^\perp$  in  $\mathbb{S}^3$  by  $\widehat{\kappa}_{\alpha\beta} := \kappa_{\alpha\beta}$ ;  $\widehat{\kappa}_{i3} := 0$  and  $\kappa_{\alpha\beta}^\perp := 0$ ;  $\kappa_{i3}^\perp := \kappa_{i3}$ , respectively. A symmetric tensor product  $\xi \otimes_s \zeta$  in  $\mathbb{R}^3$  is defined by  $(\xi \otimes_s \zeta)_{ij} = (\xi_i \zeta_j + \xi_j \zeta_i)/2$  for all  $\xi, \zeta \in \mathbb{R}^3$ . Let  $\text{Lin}(\mathbb{S}^3)$  denote the space of linear symmetric mappings from  $\mathbb{S}^3$  into itself.

Here, within the context of small strains, we study the dynamic response of a thin viscoelastic plate of nonlinear Kelvin-Voigt type subjected to a given load. The reference configuration of the plate is the closure of  $\Omega^\varepsilon := \omega \times (-\varepsilon, \varepsilon)$  whose thickness is  $2\varepsilon$  and the middle surface of the plate  $\omega$  is a bounded domain in  $\mathbb{R}^2$  with Lipschitz continuous boundary  $\partial\omega$ . We refer to the lateral, upper and lower faces of the plate as  $\Gamma_{\text{lat}}^\varepsilon := \partial\omega \times [-\varepsilon, \varepsilon]$ ,  $\Gamma_+^\varepsilon := \omega \times \{+\varepsilon\}$  and  $\Gamma_-^\varepsilon := \omega \times \{-\varepsilon\}$ , respectively. Given a partition  $\{\gamma_D, \gamma_N, \gamma_C\}$  of the boundary  $\partial\omega$ , the plate is clamped on a portion  $\Gamma_D^\varepsilon := \gamma_D \times [-\varepsilon, \varepsilon]$  with  $\mathfrak{h}_1(\gamma_D) > 0$ , where  $\mathfrak{h}_n$  is the  $n$ -dimensional Hausdorff measure.

It is subjected to surface forces of density  $g^\varepsilon$  on  $\Gamma_N^\varepsilon := \gamma_N \times [-\varepsilon, \varepsilon] \cup \Gamma_+^\varepsilon \cup \Gamma_-^\varepsilon$  and body force of density  $f^\varepsilon$ , while it is in bilateral contact with a rigid body by Norton or Tresca friction on  $\Gamma_C^\varepsilon := \gamma_C \times [-\varepsilon, \varepsilon]$  with a “viscosity” coefficient  $\mu$  (see Figure 1).

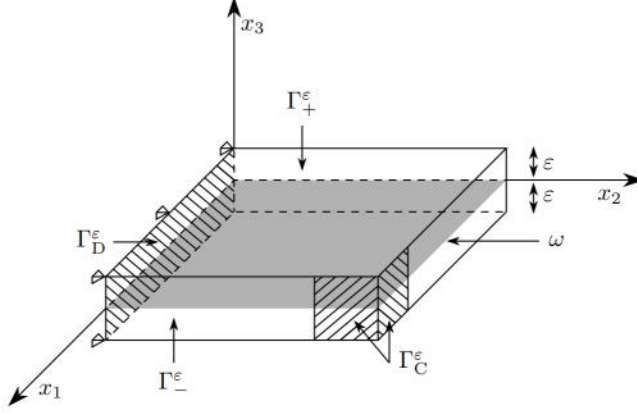

Figure 1. Plate  $\Omega^\varepsilon$  in three dimensions with middle surface  $\omega$  and thickness  $2\varepsilon$ .

The density  $\varrho\delta^\varepsilon$  of the plate, where  $\varrho$  is a positive number, and the elasticity tensor  $a^\varepsilon$  of the plate satisfy:

$$(H0) \quad \begin{cases} \delta^\varepsilon \in L^\infty(\Omega^\varepsilon); \exists \alpha > 0 \text{ s.t. } \delta^\varepsilon(x^\varepsilon) \geq \alpha \text{ a.e. } x^\varepsilon \in \Omega^\varepsilon, \\ a^\varepsilon \in L^\infty(\Omega^\varepsilon; \text{Lin}(\mathbb{S}^3)); \alpha|e|^2 \leq a^\varepsilon(x^\varepsilon)e \cdot e \quad \forall e \in \mathbb{S}^3, \text{ a.e. } x^\varepsilon \in \Omega^\varepsilon. \end{cases}$$

The density of the viscous pseudo-potential is denoted by  $b\mathcal{D}_v^\varepsilon$ , where  $b$  is a positive number and  $\mathcal{D}_v^\varepsilon$  is a measurable function on  $\Omega^\varepsilon$  and convex on  $\mathbb{S}^3$  satisfying

$$\exists q \in [1, 2], \exists \beta > 0; \quad -\alpha \leq \mathcal{D}_v^\varepsilon(x^\varepsilon, e) \leq \beta(1 + |e|^q) \quad \forall e \in \mathbb{S}^3, \text{ a.e. } x^\varepsilon \in \Omega^\varepsilon.$$

Thus, if  $s := (\varepsilon, \varrho, \mu, b)$  denotes the key data of the plate, the displacement and velocity fields  $(u^s, v^s) =: U^s$  have to solve the following problem:

$$(P^s) \quad \left\{ \begin{array}{l} \text{Find } (u^s, v^s = \partial u^s / \partial t) \text{ sufficiently smooth in } \Omega^\varepsilon \times [0, T] \text{ such that} \\ u^s = 0 \text{ on } \Gamma_D^\varepsilon \times [0, T], \quad u_N^s = 0 \text{ on } \Gamma_C^\varepsilon \times [0, T], \\ (u^s(\cdot, 0), v^s(\cdot, 0)) = U^{s0} := (u^{s0}, v^{s0}) \text{ in } \Omega^\varepsilon, \\ \int_{\Omega^\varepsilon} \varrho \delta^\varepsilon \frac{\partial^2 u^s}{\partial t^2} \cdot v \, dx^\varepsilon + \int_{\Omega^\varepsilon} a^\varepsilon e^\varepsilon(u^s) \cdot e^\varepsilon(v) \, dx^\varepsilon \\ \quad + \int_{\Omega^\varepsilon} b(\mathcal{D}_v^\varepsilon(e^\varepsilon(v^s + v)) - \mathcal{D}_v^\varepsilon(e^\varepsilon(v))) \, dx^\varepsilon \\ \quad + \int_{\Gamma_C^\varepsilon} \mu(\phi_p(v_T^s + v_T) - \phi_p(v_T)) \, dh_2 \geq \int_{\Omega^\varepsilon} f^\varepsilon \cdot v \, dx^\varepsilon + \int_{\Gamma_N^\varepsilon} g^\varepsilon \cdot v \, dh_2, \\ \text{for all } v \text{ sufficiently smooth in } \Omega^\varepsilon \text{ and such that } v = 0 \text{ on } \Gamma_D^\varepsilon, \quad v_N = 0 \text{ on } \Gamma_C^\varepsilon, \end{array} \right.$$

where  $t$  is the time,  $T > 0$ ,  $\phi_p(\xi) = |\xi|^p/p$  for all  $\xi$  in  $\mathbb{R}^3$ ,  $1 \leq p \leq 2$  ( $p = 1$  describing Tresca friction while  $1 < p \leq 2$  deals with Norton friction),  $e^\varepsilon(u)$  is the linearized strain tensor associated with the displacement field  $u$  (the symmetric part of  $\nabla^\varepsilon u$ , the gradient of  $u$  with respect to  $x^\varepsilon$ -variable), and  $u_N := u \cdot n^\varepsilon$ ,  $u_T := u - (u \cdot n^\varepsilon)n^\varepsilon$  are the normal and tangential components of  $u$  on a part of  $\partial\Omega^\varepsilon$  with outward unit normal vector  $n^\varepsilon$ . Denoting the time derivative by an upper dot and introducing  $\partial J(v)$ , the subdifferential at  $v$  of any lower semicontinuous convex function  $J$ , the stress tensor  $\sigma^s$  and the field of displacement  $u^s$  satisfy:

$$\begin{cases} \sigma^s \in a^\varepsilon e^\varepsilon(u^s) + b\partial D_v^\varepsilon(e^\varepsilon(\dot{u}^s)) \text{ in } \Omega^\varepsilon, \\ -(\sigma^s n^\varepsilon)_T \in \partial\phi_p(\dot{u}_T^s), \quad u_N^s = 0 \text{ on } \Gamma_C^\varepsilon, \\ -\operatorname{div}^\varepsilon \sigma^s - f^\varepsilon + \rho\delta^\varepsilon \ddot{u}^s = 0 \text{ in } \Omega^\varepsilon, \\ \sigma^s n^\varepsilon = g^\varepsilon \text{ on } \Gamma_N^\varepsilon, \quad u^s = 0 \text{ on } \Gamma_D^\varepsilon, \end{cases}$$

where  $\operatorname{div}^\varepsilon$  obviously stands for the divergence with respect to  $x^\varepsilon$ -variable.

### 3. EXISTENCE AND UNIQUENESS

To obtain the existence and uniqueness result, we make an assumption on the loading

$$(H1) \quad (f^\varepsilon, g^\varepsilon) \in \operatorname{BV}^1(0, T; L^2(\Omega^\varepsilon, \mathbb{R}^3) \times L^2(\Gamma_N^\varepsilon, \mathbb{R}^3)),$$

where for all Hilbert space  $H$ ,  $\operatorname{BV}^1(0, T; H)$  comprises all elements of  $\operatorname{BV}(0, T; H)$  with distributional time derivative in  $\operatorname{BV}(0, T; H)$  which is the space of all elements of  $L^1(0, T; H)$  whose distributional time derivative is a  $H$ -valued measure.

The field  $U^s$  is split into  $U^s = U^{se} + U^{sr}$ ; the field  $U^{se}(t) := (u^{se}(t), 0)$  is defined by

$$(3.1) \quad u^{se}(t) \in \mathcal{U}^s; \quad \varphi^s(u^{se}(t), u') = L^\varepsilon(t)(u') \quad \forall u' \in \mathcal{U}^s, \quad \forall t \in [0, T],$$

where

$$(3.2) \quad \begin{aligned} \mathcal{U}^s &:= \{u \in H^1(\Omega^\varepsilon, \mathbb{R}^3); u = 0 \text{ on } \Gamma_D^\varepsilon, u_N = 0 \text{ on } \Gamma_C^\varepsilon\}, \\ \varphi^s(u, u') &:= \frac{1}{\varepsilon^3} \int_{\Omega^\varepsilon} a^\varepsilon e^\varepsilon(u) \cdot e^\varepsilon(u') \, dx^\varepsilon \quad \forall u, u' \in \mathcal{U}^s, \\ L^\varepsilon(t)(u') &:= \frac{1}{\varepsilon^3} \left( \int_{\Omega^\varepsilon} f^\varepsilon(x^\varepsilon, t) \cdot u' \, dx^\varepsilon + \int_{\Gamma_N^\varepsilon} g^\varepsilon(x^\varepsilon, t) \cdot u' \, d\mathfrak{h}_2 \right) \\ &\quad \forall u' \in \mathcal{U}^s, \quad \forall t \in [0, T]. \end{aligned}$$

Because of (H0) and (H1), the displacement field  $u^{se}$  is well-defined and belongs to  $\operatorname{BV}^1(0, T; \mathcal{U}^s)$ .



The remaining part  $U^{sr}$  of  $U^s$  will be involved in an evolution equation in a Hilbert space  $\mathcal{H}^s$  of possible states with finite total mechanical energy governed by a maximal-monotone operator  $A^s$ . We introduce  $k^s$  the bilinear form associated with the kinetic energy

$$(3.3) \quad k^s(v, v') := \frac{1}{\varepsilon^3} \int_{\Omega^\varepsilon} \rho \delta^\varepsilon v \cdot v' dx^\varepsilon \quad \forall v, v' \in \mathcal{V}^s := L^2(\Omega^\varepsilon, \mathbb{R}^3),$$

and define the space  $\mathcal{H}^s := \mathcal{U}^s \times \mathcal{V}^s$ , endowing it with the following inner product and norm:

$$\begin{aligned} \langle U, U' \rangle^s &:= \varphi^s(u, u') + k^s(v, v') \quad \forall U = (u, v), U' = (u', v') \in \mathcal{H}^s, \\ |U|^s &:= [\langle U, U \rangle^s]^{1/2}. \end{aligned}$$

The global pseudo-potential of dissipation  $\mathcal{D}_f^s$  involving friction is:

$$\mathcal{D}_f^s(v) := \frac{\mu}{\varepsilon^3} \int_{\Gamma_\varepsilon^c} \phi_p(v_T) d\mathfrak{h}_2 \quad \forall v \in \mathcal{U}^s,$$

while the global viscous pseudo-potential of dissipation is

$$\mathcal{D}_v^s(v) := \frac{b}{\varepsilon^3} \int_{\Omega^\varepsilon} \mathcal{D}_v^\varepsilon(e^\varepsilon(v)) dx^\varepsilon \quad \forall v \in \mathcal{U}^s,$$

where  $p = 1$  refers to Tresca and  $p \in (1, 2]$  to Norton tangential friction with bilateral contact. The rationale of the normalizing factor  $\varepsilon^3$  for energies and global pseudo-potential of dissipation will clearly appear in the next section.

So the multi-valued operator  $A^s$  defined on  $\mathcal{H}^s$  by

$$\begin{cases} D(A^s) := \{U = (u, v) \in \mathcal{H}^s; \text{ (i) } v \in \mathcal{U}^s, \text{ (ii) } \exists w \in \mathcal{V}^s \text{ s.t.} \\ \quad \varphi^s(u, v') + k^s(w, v') + \mathcal{D}_f^s(v + v') - \mathcal{D}_f^s(v) \\ \quad \quad \quad + \mathcal{D}_v^s(v + v') - \mathcal{D}_v^s(v) \geq 0 \quad \forall v' \in \mathcal{U}^s\}, \\ -A^s U = \{(v, w); w \text{ satisfies (ii) of definition of } D(A^s)\}, \end{cases}$$

obviously satisfies the following proposition.

**Proposition 3.1.** *Operator  $A^s$  is maximal monotone and for all  $\psi^s = (\psi_u^s, \psi_v^s)$  in  $\mathcal{H}^s$*

$$\begin{cases} \bar{U}^s = (\bar{u}^s, \bar{v}^s) \text{ s.t.} \\ \bar{U}^s + A^s \bar{U}^s \ni \psi^s \end{cases} \Leftrightarrow \begin{cases} \bar{u}^s = \bar{v}^s + \psi_u^s, \\ \text{where } \bar{v}^s \text{ is the unique minimizer on } \mathcal{U}^s \text{ of } J^s; \\ J^s(v) := \frac{1}{2} [|(v, v)|^s]^2 + \langle (\psi_u^s, -\psi_v^s), (v, v) \rangle^s \\ \quad \quad \quad + \mathcal{D}_f^s(v) + \mathcal{D}_v^s(v) \quad \forall v \in \mathcal{U}^s. \end{cases}$$

Finally, as the very definition of  $\mathcal{D}_f^s$  and  $\mathcal{D}_v^s$  implies that  $(\mathcal{P}^s)$  is formally equivalent to

$$(\mathcal{P}^s) \quad \begin{cases} \frac{dU^s}{dt} + A^s(U^s - U^{se}) \ni 0, \\ U^s(0) = U^{s0}, \end{cases}$$

Propositions 3.2 and 3.3 in [3] yield:

**Theorem 3.1.** *Under assumptions (H1) and*

$$(H2) \quad U^{s0} \in U^{se}(0) + D(A^s),$$

*problem  $(\mathcal{P}^s)$  has a unique solution  $U^s$  belonging to  $W^{1,\infty}(0, T; \mathcal{H}^s)$  and the first line of  $(\mathcal{P}^s)$  is satisfied almost everywhere in  $(0, T]$ .*

#### 4. ASYMPTOTIC BEHAVIOR

Now we consider  $s$  to be a quadruplet of parameters taking values in a countable subset  $\mathcal{S}$  of  $(0, \infty)^4$  with a unique cluster point  $\bar{s}$  in  $\{0\} \times [0, \infty) \times [0, \infty)^2$ . The study [7] leads us to speculate on the limit behavior in the current study and advises separating the limit model into twelve cases, each indexed by  $\mathbf{I} = (I_1, I_2, I_3)$  in  $\{1, 2\} \times \{1, 2, 3\} \times \{1, 2\}$ . Let

$$\varrho^{*\mathbf{I}_1} = \begin{cases} \varrho\varepsilon^{-2}, & I_1 = 1, \\ \varrho, & I_1 = 2, \end{cases}$$

$$\mu^{*\mathbf{I}_2} = \begin{cases} \mu\varepsilon^{-2}, & I_2 = 1, \\ \mu\varepsilon^{-(2-p)}, & I_2 = 2, 3, \end{cases} \quad b^{*\mathbf{I}_3} = b\varepsilon^{-(2-q)}, \quad I_3 = 1, 2.$$

We make the following assumption to account for the magnitudes of density, thickness and viscosity:

$$(H3) \quad \begin{cases} \text{there exists } (\bar{\varrho}^{\mathbf{I}_1}, \bar{\mu}^{\mathbf{I}_2}, \bar{b}^{\mathbf{I}_3}) \text{ in } (0, \infty) \times [0, \infty] \times [0, \infty] \text{ such that} \\ \bar{\varrho}^{\mathbf{I}_1} = \lim_{s \rightarrow \bar{s}} \varrho^{*\mathbf{I}_1}, \\ \bar{\mu}^{\mathbf{I}_2} = \lim_{s \rightarrow \bar{s}} \mu^{*\mathbf{I}_2} \text{ with } \bar{\mu}^1, \bar{\mu}^2 \in [0, \infty) \text{ and } \bar{\mu}^3 = \infty, \\ \bar{b}^{\mathbf{I}_3} = \lim_{s \rightarrow \bar{s}} b^{*\mathbf{I}_3} \text{ with } \bar{b}^2 = \infty. \end{cases}$$

Following [7] we introduce  $\bar{\Omega}$ , the closure of  $\Omega := \omega \times (-1, 1)$ , through a mapping  $\pi^\varepsilon$ :

$$x = (\hat{x}, x_3) \in \bar{\Omega} \mapsto x^\varepsilon = \pi^\varepsilon x := (\hat{x}, \varepsilon x_3) \in \bar{\Omega}^\varepsilon.$$

In the sequel,  $x^\varepsilon$  and  $x$  are systematically connected through  $x^\varepsilon = \pi^\varepsilon x$ . Similarly to  $\Omega$ , we discard index  $\varepsilon$  from the inverse image of  $\Gamma_\pm^\varepsilon, \Gamma_D^\varepsilon, \Gamma_N^\varepsilon, \Gamma_C^\varepsilon, \Gamma_{\text{lat}}^\varepsilon$  by  $(\pi^\varepsilon)^{-1}$ . Let  $\alpha$  and  $\beta$  be fixed positive real numbers, we further make a due assumption (H4) on the density and the elasticity tensor of the plate, and on the loading  $(f^\varepsilon, g^\varepsilon)$ :

$$(H4) \left\{ \begin{array}{l} \exists (\delta, a) \in L^\infty(\Omega, \mathbb{R} \times \text{Lin}(\mathbb{S}^3)) \text{ s.t.} \\ \quad \alpha \leq \delta(x), \quad \alpha |e|^2 \leq a(x) e \cdot e \quad \forall e \in \mathbb{S}^3, \text{ a.e. } x \in \Omega, \\ \quad \delta^\varepsilon(x^\varepsilon) = \delta(x), \quad a^\varepsilon(x^\varepsilon) = a(x), \text{ a.e. } x \in \Omega, \\ \exists \mathcal{D}_v \text{ measurable in } \Omega, \text{ convex on } \mathbb{S}^3 \text{ s.t.} \\ \quad \exists q \in [1, 2], \quad -\alpha \leq \mathcal{D}_v(x, e) \leq \beta(1 + |e|^q), \\ \quad \mathcal{D}_v^\varepsilon(x^\varepsilon, e) = \mathcal{D}_v(x, e), \end{array} \right\} \quad \forall e \in \mathbb{S}^3, \text{ a.e. } x \in \Omega.$$

$$\left\{ \begin{array}{l} \exists (f, g) \in \text{BV}^1(0, T; L^2(\Omega, \mathbb{R}^3) \times L^2(\Gamma_N, \mathbb{R}^3)) \text{ s.t.} \\ \quad \widehat{f}^\varepsilon(x^\varepsilon) = \varepsilon \widehat{f}(x), \quad f_3^\varepsilon(x^\varepsilon) = \varepsilon^2 f_3(x) \quad \forall x \in \Omega, \\ \quad \widehat{g}^\varepsilon(x^\varepsilon) = \varepsilon^2 \widehat{g}(x), \quad g_3^\varepsilon(x^\varepsilon) = \varepsilon^3 g_3(x) \quad \forall x \in \Gamma_N \cap \Gamma_\pm, \\ \quad \widehat{g}^\varepsilon(x^\varepsilon) = \varepsilon \widehat{g}(x), \quad g_3^\varepsilon(x^\varepsilon) = \varepsilon^2 g_3(x) \quad \forall x \in \Gamma_N \cap \Gamma_{\text{lat}}. \end{array} \right.$$

From now on the letter  $c$  or  $C$  will denote various constants independent of  $s$ , which may differ from line to line.

**4.1. A candidate for the limit framework.** To display the asymptotic behavior of  $U^s$ , we use a simple scaling mapping  $S_\varepsilon$  from  $L^2(\Omega^\varepsilon, \mathbb{R}^3)$  into  $L^2(\Omega, \mathbb{R}^3)$  defined by:

$$(4.1) \quad S_\varepsilon w(x) := \left( \frac{1}{\varepsilon} \widehat{w}(x^\varepsilon), w_3(x^\varepsilon) \right) \quad \text{a.e. } x \in \Omega, \quad \forall w \in L^2(\Omega^\varepsilon, \mathbb{R}^3).$$

With this scaling, for all  $w$  in  $H^1(\Omega^\varepsilon, \mathbb{R}^3)$  we have  $e^\varepsilon(w)(x^\varepsilon) = \varepsilon e(\varepsilon, S_\varepsilon w)(x)$  a.e.  $x$  in  $\Omega$ , where:

$$(4.2) \quad e_{ij}(\varepsilon, z) := \left. \begin{array}{l} e_{ij}(z) \quad \text{for } 1 \leq i \leq j \leq 2, \\ \varepsilon^{-1} e_{ij}(z) \quad \text{for } 1 \leq i \leq 2, \quad j = 3, \\ e_{ji}(\varepsilon, z) \quad \text{for } 1 \leq j < i \leq 3, \\ \varepsilon^{-2} e_{33}(z) \quad \text{for } i = j = 3, \end{array} \right\} \quad \forall z \in H^1(\Omega, \mathbb{R}^3).$$

$$e_{ij}(z) := \frac{1}{2} (\partial_i z_j + \partial_j z_i),$$

Therefore, the bilinear forms  $\varphi^s$  in (3.2) and  $k^s$  in (3.3) become:

$$(4.3) \quad \varphi^s(u, u') = \int_\Omega a e(\varepsilon, S_\varepsilon u) \cdot e(\varepsilon, S_\varepsilon u') \, dx \quad \forall u, u' \in U^s,$$

$$(4.4) \quad k^s(v, v') = \int_\Omega \rho \delta \left( (\widehat{S_\varepsilon v}) \cdot (\widehat{S_\varepsilon v'}) + \frac{1}{\varepsilon^2} (S_\varepsilon v)_3 (S_\varepsilon v')_3 \right) \, dx \quad \forall v, v' \in \mathcal{V}^s.$$

Before introducing a suitable space for the limit fields, we recall some classical spaces useful in the mathematical modeling of linearized elastic plates

$$(4.5) \quad H_{\Gamma_D}^1(\Omega, \mathbb{R}^3) = \{w \in H^1(\Omega, \mathbb{R}^3); w = 0 \text{ on } \Gamma_D\},$$

$$(4.6) \quad V_{\text{KL}} := \{w \in H_{\Gamma_D}^1(\Omega, \mathbb{R}^3); e_{i3}(w) = 0\},$$

and define:

$$(4.7) \quad \left\{ \begin{array}{l} \mathcal{U}^0 := \{w \in V_{\text{KL}}; w_N = 0 \text{ on } \Gamma_C\}, \quad \mathcal{U}^1 := H^1(-1, 1; L^2(\omega, \mathbb{R}^3))/L^2(\omega, \mathbb{R}^3), \\ \mathcal{U} := \mathcal{U}^0 \times \mathcal{U}^1, \quad E_u := e(u^0) + \partial_3 u^1 \otimes_s e_3 \quad \forall u = (u^0, u^1) \in \mathcal{U}, \\ \mathcal{V}^1 := L^2(\Omega), \quad \mathcal{V}^2 := \{v \in L^2(\Omega, \mathbb{R}^3); v_3 = 0\}, \\ \mathcal{H}^I := \mathcal{U} \times \mathcal{V}^{I_1} \quad \forall I = (I_1, I_2, I_3) \in \{1, 2\} \times \{1, 2, 3\} \times \{1, 2\}, \\ \varphi(u, u') := \int_{\Omega} a E_u \cdot E_{u'} dx \quad \forall u, u' \in \mathcal{U}, \\ k^1(v, v') := \bar{\rho}^1 \int_{\Omega} \delta v v' dx \quad \forall v, v' \in \mathcal{V}^1, \quad k^2(v, v') := \bar{\rho}^2 \int_{\Omega} \delta \widehat{v} \cdot \widehat{v}' dx \quad \forall v, v' \in \mathcal{V}^2, \\ \langle U, U' \rangle^I := \varphi(u, u') + k^{I_1}(v, v') \quad \forall U = (u, v), U' = (u', v') \in \mathcal{H}^I, \\ |U|^I := [\langle U, U \rangle^I]^{1/2}. \end{array} \right.$$

Clearly,  $\mathcal{H}^I$  equipped with the inner product  $\langle \cdot, \cdot \rangle^I$  is a Hilbert space and taking into account the fundamental link between velocity and displacement, we straightforwardly deduce:

**Proposition 4.1.** *For every sequence  $\mathcal{X}^s = (\mathcal{X}_u^s, \mathcal{X}_v^s)$  in  $\mathcal{H}^s$  such that  $|\mathcal{X}^s|^s$  is uniformly bounded, there exists a not relabeled subsequence and  $\mathcal{X}^I = (\mathcal{X}_u^I, \mathcal{X}_v^I)$  in  $\mathcal{H}^I$  such that:*

- (i)  $(E_{\mathcal{X}_u^I}, \mathcal{X}_v^I)$  is the weak limit in  $L^2(\Omega, \mathbb{S}^3 \times \mathbb{R}^{2I_1-1})$  of  $(e(\varepsilon, S_\varepsilon \mathcal{X}_u^s), (S_\varepsilon \mathcal{X}_v^s)_3)$  when  $I_1 = 1$  or of  $(e(\varepsilon, S_\varepsilon \mathcal{X}_u^s), S_\varepsilon \mathcal{X}_v^s)$  when  $I_1 = 2$ ,
- (2)  $|\mathcal{X}^I|^I \leq \varliminf_{s \rightarrow \bar{s}} |\mathcal{X}^s|^s$ .

Hence,  $\mathcal{H}^I$  appears to be suitable for describing the asymptotic behavior. Moreover, it is exactly the appropriate space because any element  $U$  of  $\mathcal{H}^I$  admits a representative  $P^{sI}U$  in  $\mathcal{H}^s$  which is energetically very close to  $U$ :

**Proposition 4.2.** *For all  $s$  in  $\mathcal{S}$  and all  $U = (u, v)$  in  $\mathcal{H}^I$ , let  $P^{sI}U := (P_u^{sI}u, P_v^{sI}v)$  in  $\mathcal{H}^s$  be defined by:*

$$(4.8) \quad \varphi^s(P_u^{sI}u, u') = \int_{\Omega} a E_u \cdot e(\varepsilon, S_\varepsilon u') dx \quad \forall u' \in \mathcal{U}^s,$$

$$(4.9) \quad k^s(P_v^{sI}v, v') = \begin{cases} k^1(v, (S_\varepsilon v')_3) & \text{if } I_1 = 1, \\ k^2(v, S_\varepsilon v') & \text{if } I_1 = 2, \end{cases} \quad \forall v' \in \mathcal{V}^s.$$

We have:

(P1) there exists  $C > 0$  s.t.  $|\mathbf{P}^{s\mathbf{I}}U|^s \leq C|U|^s$  for all  $U \in \mathcal{H}^1$  for all  $s \in \mathcal{S}$ ,

(P2)  $\lim_{s \rightarrow \bar{s}} |\mathbf{P}^{s\mathbf{I}}U|^s = |U|^s$  for all  $U \in \mathcal{H}^1$ ,

(P3)

$$\text{i.} \quad \lim_{s \rightarrow \bar{s}} \frac{1}{\varepsilon^3} \int_{\Omega^\varepsilon} a^\varepsilon [e^\varepsilon(\mathbf{P}_u^{s\mathbf{I}}u) - E_u^\varepsilon] \cdot [e^\varepsilon(\mathbf{P}_u^{s\mathbf{I}}u) - E_u^\varepsilon] dx^\varepsilon = 0,$$

with  $E_u^\varepsilon(x^\varepsilon) := \varepsilon E_u(x)$  a.e.  $x^\varepsilon = \pi^\varepsilon x \in \Omega^\varepsilon$  for all  $u \in \mathcal{U}$ ;

$$\text{ii.} \quad P_v^{s\mathbf{I}}v = V_v^{\varepsilon\mathbf{I}} := \begin{cases} \frac{\varrho^{s\mathbf{I}_1}}{\bar{\varrho}^{\mathbf{I}_1}}(S_\varepsilon)^{-1}(0, v_3) & \text{if } \mathbf{I}_1 = 1, \\ \frac{\varrho^{s\mathbf{I}_1}}{\bar{\varrho}^{\mathbf{I}_1}}(S_\varepsilon)^{-1}v & \text{if } \mathbf{I}_1 = 2. \end{cases}$$

*Proof.* Choosing  $u' = \xi^s := \mathbf{P}_u^{s\mathbf{I}}u$  and  $v' = \mathbf{P}_v^{s\mathbf{I}}v$  in (4.8) and (4.9), respectively, the Cauchy-Schwarz inequality and (4.3) imply

$$(4.10) \quad \begin{cases} \varphi^s(\mathbf{P}_u^{s\mathbf{I}}u, \mathbf{P}_u^{s\mathbf{I}}u) \leq \varphi(u, u), \\ k^s(\mathbf{P}_v^{s\mathbf{I}}v, \mathbf{P}_v^{s\mathbf{I}}v) \leq k^{\mathbf{I}_1}(v, v). \end{cases}$$

Combining these two inequalities gives (P1) straightforwardly.

Because of (4.10), the sequence  $e(\varepsilon, S_\varepsilon \xi^s)$  is bounded in  $L^2(\Omega, \mathbb{S}^3)$  so that the Korn inequality and  $\varepsilon < 1$  yield:

$$c|S_\varepsilon \xi^s|_{H^1(\Omega, \mathbb{R}^3)}^2 \leq |e(S_\varepsilon \xi^s)|_{L^2(\Omega, \mathbb{S}^3)}^2 \leq |e(\varepsilon, S_\varepsilon \xi^s)|_{L^2(\Omega, \mathbb{S}^3)}^2 \leq C.$$

Therefore, there exist a not relabeled subsequence and  $(\bar{\xi}^0, \bar{\kappa})$  in  $\mathcal{U}^0 \times L^2(\Omega, \mathbb{S}^3)$  such that:

$$(4.11) \quad (S_\varepsilon \xi^s, e(\varepsilon, S_\varepsilon \xi^s)) \text{ weakly converges in } H^1(\Omega, \mathbb{R}^3) \times L^2(\Omega, \mathbb{S}^3) \\ \text{towards } (\bar{\xi}^0, \bar{\kappa}), \quad \widehat{\bar{\kappa}} = e(\bar{\xi}^0).$$

Similarly to periodic homogenization problems treated by two-scale convergence [13], [1], we will show that the limit in  $L^2(\Omega, \mathbb{S}^3)$  of the scaled strain  $e(\varepsilon, S_\varepsilon \mathbf{P}_u^{s\mathbf{I}}u)$  will involve an additional displacement field  $\bar{\xi}^1$  so that the physical field  $\frac{1}{\varepsilon} e^\varepsilon(\xi^s)$  “3d-2d converges” towards  $E_u$  (see Appendix). As there exists  $\bar{\xi}^1$  in  $\mathcal{U}^1$  such that

$$\bar{\kappa}^\perp = \partial_3 \bar{\xi}^1 \otimes_s e_3,$$

where  $\bar{\xi}_i^1 := \int_{-1}^{x_3} (2 - \delta_{i3}) \bar{\kappa}_{i3}(\hat{x}, \tau) d\tau$  with  $\delta_{ij}$  the Kronecker symbol, then we have (see (4.7))  $\bar{\kappa} = \widehat{\bar{\kappa}} + \bar{\kappa}^\perp = E_{\bar{\xi}}^1$  with  $\bar{\xi} = (\bar{\xi}^0, \bar{\xi}^1)$ .

Now we choose  $u' = \xi + \varepsilon(\widehat{\xi}^1, \varepsilon\xi_3^1)$  in (4.8), with  $\xi$  arbitrary in  $\mathcal{U}^0$  and  $\xi^1$  arbitrary in  $(\mathcal{U}^1 \cap H^1(-1, 1; C_0^\infty(\omega, \mathbb{R}^3)))/L^2(\omega, \mathbb{R}^3)$ , which is obviously dense in  $\mathcal{U}^1$ , and obtain

$$\bar{\xi} \in \mathcal{U}, \quad \int_{\Omega} aE_{\bar{\xi}} \cdot E_{\xi} \, dx = \int_{\Omega} aE_u \cdot E_{\xi} \, dx \quad \forall \xi \in \mathcal{U},$$

which implies  $\bar{\xi} = u$  and the whole sequence satisfies (4.11).

Next choosing  $u' = \xi^s$  in (4.8) yields:

$$\lim_{s \rightarrow \bar{s}} \int_{\Omega} ae(\varepsilon, S_{\varepsilon}\xi^s) \cdot e(\varepsilon, S_{\varepsilon}\xi^s) \, dx = \int_{\Omega} aE_u \cdot E_u \, dx.$$

Therefore,  $e(\varepsilon, S_{\varepsilon}\xi^s)$  converges *strongly* in  $L^2(\Omega, \mathbb{S}^3)$  towards  $E_u$ , that is to say (P3)i and  $\lim_{s \rightarrow \bar{s}} \varphi^s(P_u^{s1}u, P_u^{s1}u) = \varphi(u, u)$ .

Lastly (P3)ii being obvious, one has  $k^s(P_v^{s1}v, P_v^{s1}v) = k^{I_1}(v, v)$  by due account of (4.4).  $\square$

Property (P2) states that any element  $U$  of  $\mathcal{H}^I$  has a representative  $P^{s1}U$  in  $\mathcal{H}^s$  whose energy  $\langle P^{s1}U, P^{s1}U \rangle^s$  is arbitrarily close to the square of the norm of  $U$  in  $\mathcal{H}^I$ , ensuring that  $\mathcal{H}^I$  is appropriate to describe the asymptotic behavior. Keep also in mind that through (4.7) the “abstract velocities” living in the space  $\mathcal{V}^{I_1}$  involve their sole transverse component when  $I_1 = 1$ .

To complete guessing the asymptotic behavior, according to Proposition 3.1, it remains to consider sequences  $z^s$  with uniformly bounded global frictional and viscous pseudo-potentials of dissipation  $\mathcal{D}_f^s(z^s)$ ,  $\mathcal{D}_v^s(z^s)$  and “total energy functional”  $[(z^s, z^s)^s]^2$  which will permit to define the space  $\mathcal{Z}^I$  of “admissible virtual generalized velocities” and the limit global potentials of dissipation  $\mathcal{D}_f^I$  and  $\mathcal{D}_v^I$ . Note that from a strictly mathematical point of view, such previous sequences stem from sequences  $\mathcal{X}^s$  such that  $\mathcal{X}^s + A^s\mathcal{X}^s$  are uniformly bounded in  $\mathcal{H}^s$ . We set:

$$(4.12) \quad \mathcal{Z}^I := \{z \in \mathcal{U}; (z^0)_3 = 0 \text{ if } I_1 = 2, (z^0)_3 = 0 \text{ on } \Gamma_C \text{ if } I_2 = 2,$$

$$(4.13) \quad \mathcal{D}_f^I(z) := \begin{cases} z^0 = 0 \text{ on } \Gamma_C \text{ if } I_2 = 3, z = 0 \text{ if } I_3 = 2\}, \\ \left\{ \begin{array}{ll} 2\bar{\mu}^1 \int_{\Gamma_C} \phi_p(z_3^0) \, d\mathfrak{h}_1 & \text{if } I_2 = 1, \\ 2\bar{\mu}^2 \int_{\Gamma_C} \phi_p(\widehat{z}_T^0) \, d\mathfrak{h}_1 & \text{if } I_2 = 2 \quad \forall z \in \mathcal{Z}^I, \\ 0 & \text{if } I_2 = 3, \end{array} \right. \end{cases}$$

$$(4.14) \quad \mathcal{D}_v^I(z) := \begin{cases} \bar{b}^1 \int_{\Omega} \mathcal{D}_v(E_z) \, dx & \text{if } I_3 = 1, \\ \mathbf{I}_{\{0\}}(z) & \text{if } I_3 = 2, \end{cases} \quad \forall z \in \mathcal{Z}^I.$$

Thus, a simple argument of lower semicontinuity and Proposition 4.1 imply:

**Proposition 4.3.** *For all sequence  $z^s$  in  $\mathcal{U}^s$  such that  $[|(z^s, z^s)|^s]^2 + \mathcal{D}_f^s(z^s) + \mathcal{D}_v^s(z^s) \leq C$ , there exists a not labeled subsequence and  $z$  in  $\mathcal{Z}^I$  such that  $e(\varepsilon, S_\varepsilon z^s)$  converges weakly in  $L^2(\Omega, \mathbb{S}^3)$  towards  $E_z$  and*

$$[|(z, (\overset{\circ}{z})^I)|^1]^2 + \mathcal{D}_f^I(z) + \mathcal{D}_v^I(z) \leq \liminf_{s \rightarrow \bar{s}} ([|(z^s, z^s)|^s]^2 + \mathcal{D}_f^s(z^s) + \mathcal{D}_v^s(z^s))$$

with

$$(4.15) \quad (\overset{\circ}{z})^I = (z^0)_3, \text{ if } I_1 = 1, \quad (\overset{\circ}{z})^I = z^0 \text{ if } I_1 = 2 \quad \forall z = (z^0, z^1) \text{ in } \mathcal{U}.$$

We are now in a position to establish a convergence result for the solution  $U^s$  to  $(\mathcal{P}^s)$  by using a nonlinear version of Trotter theory of approximation of semi-groups acting on variable spaces, as developed in the Appendix of [3], which is very efficient in many problems where the functional spaces have to depend on physical parameter (s) as it is the case here (see [10]).

#### 4.2. Trotter theory of operators acting on variable Hilbert spaces.

Let  $H_n, H$  be Hilbert spaces with norms  $|\cdot|_{H_n}, |\cdot|_H$ , respectively, for each positive integer  $n$  and  $P_n$  a sequence of linear operators from  $H$  into  $H_n$  satisfying:

- (T1) there exists  $C > 0$  such that  $|P_n X|_{H_n} \leq C|X|_H$  for all  $X \in H$  for all  $n \in \mathbb{N}$ ,  
(T2)  $\lim_{n \rightarrow \infty} |P_n X|_{H_n} = |X|_H$  for all  $X \in H$ .

A sequence  $(X_n)_{n \in \mathbb{N}}$  with  $X_n$  in  $H_n$  for all  $n$  in  $\mathbb{N}$  is said to converge in the sense of Trotter towards  $X$  in  $H$  if

$$\lim_{n \rightarrow \infty} |P_n X - X_n|_{H_n} = 0.$$

One has the following convergence result (see [8]):

**Theorem 4.1.** *Let  $A_n: H_n \rightrightarrows H_n$ ,  $A: H \rightrightarrows H$  be multivalued maximal monotone operators,  $F_n \in L^1(0, T; H_n)$ ,  $F \in L^1(0, T; H)$ ,  $X_n^0 \in \overline{D(A_n)}$ ,  $X^0 \in \overline{D(A)}$  and let  $X_n, X$  be the weak solution to*

$$\begin{cases} \frac{dX_n}{dt} + A_n X_n \ni F_n, \\ X_n(0) = X_n^0, \end{cases} \quad \begin{cases} \frac{dX}{dt} + AX \ni F, \\ X(0) = X^0. \end{cases}$$

If

- (i)  $\lim_{n \rightarrow \infty} |(\mathbb{1} + A_n)^{-1} P_n z - P_n (\mathbb{1} + A)^{-1} z|_{H_n} = 0$  for all  $z \in H$ ,  
(ii)  $\lim_{n \rightarrow \infty} |P_n X^0 - X_n^0|_{H_n} = 0$ ,  $\lim_{n \rightarrow \infty} \int_0^T |P_n F(t) - F_n(t)|_{H_n} dt = 0$ ,

where  $\mathbb{1}$  denotes the identity operator in both spaces  $H_n$  and  $H$ , then  $X_n$  converges in the sense of Trotter towards  $X$  uniformly on  $[0, T]$ , namely,

$$\lim_{n \rightarrow \infty} \sup_{t \in [0, T]} |\mathbb{P}_n X(t) - X_n(t)|_{H_n} = 0$$

with moreover,

$$\lim_{n \rightarrow \infty} \sup_{t \in [0, T]} ||X_n(t)|_{H_n} - |X(t)|_H| = 0.$$

**4.3. Convergence results.** We can now use the Trotter theory because of Propositions 4.1 and 4.2, and we get:

**Proposition 4.4.** *The sequence  $\mathcal{X}^s = (\mathcal{X}_u^s, \mathcal{X}_v^s)$  in  $\mathcal{H}^s$  converges in the sense of Trotter towards  $\mathcal{X} = (\mathcal{X}_u, \mathcal{X}_v)$  in  $\mathcal{H}^I$  if and only if both limits are satisfied:*

- (i)  $\lim_{s \rightarrow \bar{s}} \frac{1}{\varepsilon^3} \int_{\Omega^\varepsilon} a^\varepsilon(e^\varepsilon(\mathcal{X}_u^s) - E_{\mathcal{X}_u}^\varepsilon) \cdot (e^\varepsilon(\mathcal{X}_u^s) - E_{\mathcal{X}_u}^\varepsilon) dx^\varepsilon = 0,$
- (ii)  $\lim_{s \rightarrow \bar{s}} k^s(\mathcal{X}_v^s - V_{\mathcal{X}_v}^{\varepsilon I}, \mathcal{X}_v^s - V_{\mathcal{X}_v}^{\varepsilon I}) = 0.$

So this notion of convergence is the appropriate one from the mechanical point of view: a convergence result of *relative* energetic gaps measured on the *physical plate* (the only one which has a meaning because the total mechanical energies are going to zero!) between the state  $\mathcal{X}^s$  and the image on the genuine physical configuration  $\Omega^\varepsilon$  of the limit state  $\mathcal{X}$ .

As for  $U^s$ , we consider  $U^{Ie} := (u^{Ie}, 0)$  such that  $u^{Ie}$  is the solution to

$$(4.16) \quad u^{Ie} \in \mathcal{U}; \quad \varphi(u^{Ie}, w) = L(w) := L^\varepsilon((S_\varepsilon)^{-1}w^0) \quad \forall w = (w^0, w^1) \in \mathcal{U}.$$

Assumption (H4) therefore implies that  $U^{Ie}$  belongs to  $BV^1(0, T; \mathcal{H}^I)$ .

Taking advantage of the concept of multivalued operators, we introduce the following operator  $A^I$ :

▷ When  $I_3 = 1$ :

$$\left\{ \begin{array}{l} D(A^I) := \{U = (u, v) \in \mathcal{H}^I; \text{ (i) } \exists \tilde{v} \in \mathcal{Z}^I \text{ s.t. } (\tilde{v})^I = v, \text{ (ii) } \exists w \in \mathcal{V}^{I_1} \text{ s.t.} \\ \langle (u, w), (z, (\tilde{z})^I) \rangle^I + \mathcal{D}_f^I(z + \tilde{v}) - \mathcal{D}_f^I(\tilde{v}) + \mathcal{D}_v^I(z + \tilde{v}) - \mathcal{D}_v^I(\tilde{v}) \geq 0 \\ \forall z \in \mathcal{Z}^I\}, \\ -A^I U = \{(\tilde{v}, w) \text{ satisfying (i) and (ii)}\}. \end{array} \right.$$

▷ When  $I_3 = 2$ :

$$\left\{ \begin{array}{l} D(A^I) := \mathcal{U} \times \{0\}, \\ -A^I U = \{0\} \times \mathcal{V}^{I_1}. \end{array} \right.$$





**Proof.** (i) According to Proposition 1,  $\bar{U}^s = (\bar{u}^s, \bar{v}^s) := (\mathbb{1} + A^s)^{-1} P^{sI} \psi$  is such that  $\bar{u}^s = \bar{v}^s + P_u^{sI} \psi_u$  and  $\bar{v}^s$  is the unique minimizer on  $\mathcal{U}^s$  of  $\tilde{J}^s$  defined by

$$\tilde{J}^s(v) = \frac{1}{2} [| (v, v) |^s]^2 + \int_{\Omega} a E_{\psi_u} \cdot e(\varepsilon, S_{\varepsilon} v) \, dx + k^{I_1}(-\psi_v, S_{\varepsilon} v) + \mathcal{D}_f^s(v) + \mathcal{D}_v^s(v) \quad \forall v \in \mathcal{U}^s.$$

Hence,  $\bar{v}^s$  is bounded in  $\mathcal{U}^s$  and  $\mathcal{V}^s$ . According to Proposition 4.3, there exist  $v^*$  in  $\mathcal{Z}^I$  and a not relabeled subsequence such that  $e(\varepsilon, S_{\varepsilon} \bar{v}^s)$  weakly converges in  $L^2(\Omega, \mathbb{S}^3)$  towards  $E_{v^*}$  and

$$J^I(v^*) \leq \varliminf_{s \rightarrow \bar{s}} \tilde{J}^s(\bar{v}^s).$$

To prove that the entire sequence converges towards  $E_{\bar{z}}$  with  $\bar{z}$  the unique minimizer of  $J^I$  on  $\mathcal{Z}^I$  and

$$(4.17) \quad J^I(\bar{z}) = \lim_{s \rightarrow \bar{s}} \tilde{J}^s(\bar{v}^s), \quad |(\bar{z}, (\bar{z})^I)|^I = \lim_{s \rightarrow \bar{s}} |(\bar{v}^s, \bar{v}^s)|^s,$$

it remains to show that for all  $z$  in  $\mathcal{Z}^I$  there exists  $z^s$  in  $H_{\Gamma_D}^1(\Omega^{\varepsilon}, \mathbb{R}^3)$  such that  $e(\varepsilon, S_{\varepsilon} z^s)$  weakly converges in  $L^2(\Omega, \mathbb{S}^3)$  towards  $E_z$  with:

$$(4.18) \quad \begin{cases} \varlimsup_{s \rightarrow \bar{s}} |(z^s, z^s)|^s \leq |(z, (\overset{\circ}{z})^I)|^I, \\ \varlimsup_{s \rightarrow \bar{s}} \mathcal{D}_f^s(z^s) \leq \mathcal{D}_f^I(z), \\ \varlimsup_{s \rightarrow \bar{s}} \mathcal{D}_v^s(z^s) \leq \mathcal{D}_v^I(z), \\ \varlimsup_{s \rightarrow \bar{s}} \tilde{J}^s(z^s) \leq J^I(z). \end{cases}$$

To accomplish this, we use a classical construction in mathematical modeling of thin plates [4], [8] which in fact consists in smoothing  $z^1$ . As there exists  $q_s$  in  $C_0^{\infty}(\Omega, \mathbb{S}^3)$  such that  $\int_{\Omega} a(q_s - E_z) \cdot (q_s - E_z) \, dx \leq C\varepsilon^2$ , the field defined by

$$(4.19) \quad \begin{aligned} (w_s)_{\alpha} &= 2\varepsilon \int_0^{x_3} \left( (q_s)_{\alpha 3}(\hat{x}, \tau) - \frac{\varepsilon}{2} \int_0^{\tau} \partial_{\alpha}(q_s)_{33}(\hat{x}, \sigma) \, d\sigma \right) d\tau, \\ (w_s)_3(x) &= \varepsilon^2 \int_0^{x_3} (q_s)_{33}(\hat{x}, \tau) \, d\tau \end{aligned}$$

belongs to  $H_{\Gamma_D \cup \Gamma_C}^1(\Omega, \mathbb{R}^3)$ . Because  $|e(\varepsilon, z^0 + w_s) - q_s|_{L^2(\Omega, \mathbb{S}^3)} \leq C\varepsilon$ , we can see that  $e(\varepsilon, z^0 + w_s)$  converges strongly in  $L^2(\Omega, \mathbb{S}^3)$  towards  $E_z$  and the four inequalities of (4.18) are satisfied with

$$(4.20) \quad z^s := (S_{\varepsilon})^{-1}(z^0 + w_s).$$

Eventually, as

$$\varphi^s(P_u^{sI} \bar{z} - \bar{v}^s, P_u^{sI} \bar{z} - \bar{v}^s) = \varphi^s(P_u^{sI} \bar{z}, P_u^{sI} \bar{z}) - 2 \int_{\Omega} a E_{\bar{z}} \cdot e(\varepsilon, S_{\varepsilon} \bar{v}^s) \, dx + \varphi^s(\bar{v}^s, \bar{v}^s),$$

Propositions 4.1 and 4.2 and (4.17) imply that  $(\bar{u}^s, \bar{v}^s)$  converges in the sense of Trotter towards  $(\bar{u}^I, \bar{v}^I)$ .

(ii) As  $U^{se}(t)$  and  $U^{Ie}(t)$  are the unique minimizers of  $\frac{1}{2}[|(\cdot, \cdot)|^s]^2 - L^\varepsilon(t)$  and  $\frac{1}{2}[|((\cdot, \cdot), \cdot)|^I]^2 - L(t)$ , respectively, it suffices to use the preceding result (i) by simply replacing the linear forms  $\int_\Omega aE_{\psi_u} \cdot e(\varepsilon, S_\varepsilon \cdot) dx$ ,  $\varphi(\psi_u, \cdot)$  by  $L^\varepsilon(t)$ ,  $L(t)$ , respectively, and make  $\varrho = \mu = 0$ ,  $\psi_v = 0$ .  $\square$

This leads us to our key convergence result:

**Theorem 4.3.** *Under assumptions (H1)–(H6), the solution  $U^s$  to  $(\mathcal{P}^s)$  converges to the solution  $U^I$  to  $(\mathcal{P}^I)$  in the sense that  $\lim_{s \rightarrow \bar{s}} |\mathbb{P}^{sI}U^I(t) - U^s(t)|^s = 0$  uniformly on  $[0, T]$ . In addition,  $\lim_{s \rightarrow \bar{s}} |U^s(t)|^s = |U^I(t)|^I$  uniformly on  $[0, T]$ .*

## 5. CONCLUSIVE REMARKS AND PROPOSAL OF AN ASYMPTOTIC MODEL

First, according to each value of  $I$  in  $\{1, 2\} \times \{1, 2, 3\} \times \{1, 2\}$ , we give a more explicit way of writing  $(\mathcal{P}^I)$  in the form of variational equations. We recall that  $\mathcal{Z}^I$  is defined in (4.12) for each  $I$  and introduce  $\langle \delta \rangle := \int_{-1}^1 \frac{1}{2} \delta(\widehat{x}, x_3) dx_3$ . For the sake of simplicity, we write  $(u^0, u^1)$  instead of  $(u^{I0}, u^{I1})$ . Denoting the time derivative by an upper dot and considering the initial conditions

$$u(0) = u^0 = (u^{0,0}, u^{0,1}), \quad v(0) = v^0 \quad \forall I,$$

the expression of the limit problem  $(\mathcal{P}^I)$  is as follows:

$$\begin{aligned} I = (1, 1, 1): \quad & 2\bar{\varrho}^{-1} \int_\omega \langle \delta \rangle \ddot{u}_3^0 z_3^0 d\widehat{x} + \int_\Omega aE_u \cdot E_z dx + \int_\Omega \bar{b}^1 (\mathcal{D}_v(E_{\dot{u}+z}) - \mathcal{D}_v(E_{\dot{u}})) dx \\ & + 2\bar{\mu}^1 \int_{\gamma_C} (\phi_p(\dot{u}_3^0 + z_3^0) - \phi_p(\dot{u}_3^0)) dh_1 \\ & \geq L(t)(z^0) \quad \forall z = (z^0, z^1) \in \mathcal{Z}^I, \end{aligned}$$

$$\begin{aligned} I = (1, 2, 1): \quad & 2\bar{\varrho}^{-1} \int_\omega \langle \delta \rangle \ddot{u}_3^0 z_3^0 d\widehat{x} + \int_\Omega aE_u \cdot E_z dx + \int_\Omega \bar{b}^1 (\mathcal{D}_v(E_{\dot{u}+z}) - \mathcal{D}_v(E_{\dot{u}})) dx \\ & + 2\bar{\mu}^2 \int_{\gamma_C} (\phi_p((\widehat{\dot{u}}^0)_T + (\widehat{z}^0)_T) - \phi_p((\widehat{\dot{u}}^0)_T)) dh_1 \\ & \geq L(t)(z^0) \quad \forall z \in \mathcal{Z}^I, \end{aligned}$$

$$u_3^0(t) = u_3^{0,0} \text{ on } \Gamma_C \quad \forall t \in [0, T],$$

$$\begin{aligned} I = (1, 3, 1): \quad & 2\bar{\varrho}^{-1} \int_\omega \langle \delta \rangle \ddot{u}_3^0 z_3^0 d\widehat{x} + \int_\Omega aE_u \cdot E_z dx + \int_\Omega \bar{b}^1 (\mathcal{D}_v(E_{\dot{u}+z}) - \mathcal{D}_v(E_{\dot{u}})) dx \\ & \geq L(t)(z^0) \quad \forall z \in \mathcal{Z}^I, \end{aligned}$$

$$u^0(t) = u^{0,0} \text{ on } \Gamma_C \quad \forall t \in [0, T],$$

$$\begin{aligned}
I = (2, 1, 1): & \quad 2\bar{\varrho}^2 \int_{\omega} \langle \delta \rangle \widehat{u}^0 \cdot \widehat{z}^0 \, d\widehat{x} + \int_{\Omega} a E_u \cdot E_z \, dx + \int_{\Omega} \bar{b}^1 (\mathcal{D}_v(E_{\dot{u}+z}) - \mathcal{D}_v(E_{\dot{u}})) \, dx \\
& \quad \geq L(t)(z^0) \quad \forall z \in \mathcal{Z}^I, \\
& \quad u_3^0(t) = u_3^{0,0} \quad \forall t \in [0, T], \\
I = (2, 2, 1): & \quad 2\bar{\varrho}^2 \int_{\omega} \langle \delta \rangle \widehat{u}^0 \cdot \widehat{z}^0 \, d\widehat{x} + \int_{\Omega} a E_u \cdot E_z \, dx + \int_{\Omega} \bar{b}^1 (\mathcal{D}_v(E_{\dot{u}+z}) - \mathcal{D}_v(E_{\dot{u}})) \, dx \\
& \quad \quad + 2\bar{\mu}^2 \int_{\gamma_C} (\phi_p((\widehat{u}^0)_T) + (\widehat{z}^0)_T) - \phi_p((\widehat{u}^0)_T) \, d\mathfrak{h}_1 \\
& \quad \geq L(t)(z^0) \quad \forall z \in \mathcal{Z}^I, \\
& \quad u_3^0(t) = u_3^{0,0} \quad \forall t \in [0, T], \\
I = (2, 3, 1): & \quad 2\bar{\varrho}^2 \int_{\omega} \langle \delta \rangle \widehat{u}^0 \cdot \widehat{z}^0 \, d\widehat{x} + \int_{\Omega} a E_u \cdot E_z \, dx + \int_{\Omega} \bar{b}^1 (\mathcal{D}_v(E_{\dot{u}+z}) - \mathcal{D}_v(E_{\dot{u}})) \, dx \\
& \quad \geq L(t)(z^0) \quad \forall z \in \mathcal{Z}^I, \\
& \quad \widehat{u}^0(t) = \widehat{u}^{0,0} \text{ on } \Gamma_C \quad \forall t \in [0, T], \\
& \quad u_3^0(t) = u_3^{0,0} \quad \forall t \in [0, T], \\
I_3 = 2: & \quad u(t) = u^0, \quad v(t) = 0.
\end{aligned}$$

Even if  $(P^I)$  involves *abstract* fields defined in an “abstract plate” occupying  $\Omega$ , we will use the language of mechanics to comment on  $(P^I)$ . Except in the case  $\bar{b}^2 = \infty$  (very high viscosity), where the motion is frozen in the initial state, the feature of the evolution is the same as in the elastic case: a juxtaposition of a dynamic evolution for a part of the displacement and of a quasi-static (possibly static) one for the other part, depending on the relative magnitudes of the density and the thickness. Dynamic evolution concerns the transverse component of the displacement for  $\varrho$  of order  $\varepsilon^2$  and the in-plane component for  $\varrho$  of order 1. As in the elastic case, the friction involves the in-plane or transverse component of the tangential velocity according to the relative magnitudes of the “viscosity coefficient”  $\mu$  and the thickness. As in the case of a purely quasi-static evolution, the Kelvin-Voigt viscosity highlights an additional state variable that we have chosen to be like a displacement, and allows to maintain this same short memory viscosity character. Moreover, the viscosity prevents the decoupling between membrane and flexural motions and problem  $(P^I)$  is therefore three-dimensional.

Next we propose our simplified but accurate enough modeling not by considering  $(S_\varepsilon)^{-1}u^{10}(t)$  but by taking into account our convergence result (see Theorem 4.3) and the crucial Proposition 4.4 which leads to

$$(5.1) \quad \lim_{s \rightarrow \bar{s}} \frac{1}{\varepsilon^3} \int_{\Omega^\varepsilon} a^\varepsilon (e^\varepsilon(u^s) - E_{u^1}^\varepsilon) \cdot (e^\varepsilon(u^s) - E_{u^1}^\varepsilon) \, dx^\varepsilon = 0.$$

Hence, as observed in [6], [10], [11], [14],  $E_{u^i}^\varepsilon$  is a good approximation of the strain tensor of  $u^s$  in the sense that the *relative error* made by replacing  $e^\varepsilon(u^s)$  by  $E_{u^i}^\varepsilon$  tends to zero! This shows that  $e^\varepsilon(u^s)$  is *not* close to  $e^\varepsilon((S_\varepsilon)^{-1}u^{10})$  *but* close to  $E_{u^i}^\varepsilon$ , the terms  $e_{i3}^\varepsilon(u^s)$  and those of  $e^\varepsilon(\widehat{(S_\varepsilon)^{-1}u^{10}})$  being of the same order of magnitude. As  $E_{u^i}^\varepsilon$  is not necessarily the strain tensor of a field of  $\mathcal{U}^s$ , we are led to use the construction (4.19)–(4.20), which supplies a field  $u^{Is}$  in  $\mathcal{U}^s$  such that

$$(5.2) \quad \lim_{s \rightarrow \bar{s}} \frac{1}{\varepsilon^3} \int_{\Omega^\varepsilon} a^\varepsilon(e^\varepsilon(u^{Is}) - E_{u^i}^\varepsilon) \cdot (e^\varepsilon(u^{Is}) - E_{u^i}^\varepsilon) dx^\varepsilon = 0.$$

Thus,  $u^{Is}$  is our proposal of approximation for  $u^s$ . It is obtained by first solving  $(\mathcal{P}^I)$  which provides  $u^I$  and actually corresponds to a three-dimensional problem yet set on a “reasonable” fixed domain  $\Omega$ , and second through the construction (4.19)–(4.20) applied to  $u^I$ , which also involves the fixed domain  $\Omega$ . It is therefore easy to implement a numerical method of approximation.

**Remark 5.1.** Note, as mentioned in part (ii) of the proof of Proposition 4.6, that this paper encompasses the full treatment of a purely linearly elastic plate in the static case.

**Remark 5.2.** It is worth to observe that in these problems concerning thin linearly elastic or nonlinear Kelvin-Voigt viscoelastic plates, the field of displacement in the real plate which occupies  $\Omega^\varepsilon$  is far from a Kirchhoff-Love field and even from a Reissner-Mindlin one because  $(E_{u^i}^\varepsilon)_{i3}$  depends on  $x_3^\varepsilon$  even in the case of an homogeneous plate. It is the *abstract* field  $u^{I0}$  which does satisfy  $e_{i3}(u^{I0}) = 0$  in  $\Omega$ !

**Remark 5.3.** It is also possible to deal with the not too much realistic case  $2 < p, q \leq \infty$  by the same method, the variant being that  $\mathcal{D}_f^s$ ,  $\mathcal{D}_v^s$ ,  $\mathcal{D}_f^I$  and  $\mathcal{D}_v^I$  are only lower semicontinuous functions and some trivial approximation processes are in order.

**Remark 5.4.** A more practical approach is when two other physical data concerning the magnitudes of the stiffness and of the loading are taken into account and we refer the reader to Remark 3 in [7] for its mathematical treatment.

## APPENDIX A. 3D-2D CONVERGENCE AND ASYMPTOTIC MODELING OF THIN PLATES

Built on the same principle as two-scale convergence [1], [13] we propose a tool particularly well suited for dimension reduction problem as is the former for periodic homogenization.

Let  $H$  be a finite dimensional space.

**Definition A.1.** A sequence of functions  $u^\varepsilon$  in  $L^2(\Omega^\varepsilon, H)$  is said to 3d-2d converge to a limit  $u_0$  belonging to  $L^2(\Omega, H)$  if, for any  $\psi$  in  $L^2(\Omega, H)$ , we have

$$(A.1) \quad \lim_{\varepsilon \rightarrow 0} \frac{1}{|\Omega^\varepsilon|} \int_{\Omega^\varepsilon} u^\varepsilon(x^\varepsilon) \psi(x^\varepsilon) dx^\varepsilon = \frac{1}{|\Omega|} \int_{\Omega} u_0(x) \psi(x) dx,$$

where we recall  $x^\varepsilon = (\hat{x}^\varepsilon, x_3^\varepsilon) = \pi^\varepsilon x := (\hat{x}, \varepsilon x_3)$  for all  $x \in \Omega$ .

**Proposition A.1.** From each sequence  $u^\varepsilon$  in  $L^2(\Omega^\varepsilon, H)$  such that

$$\frac{1}{|\Omega^\varepsilon|} |u^\varepsilon|_{L^2(\Omega^\varepsilon, H)}^2$$

is bounded we can extract a subsequence, and there exists a limit  $u_0$  in  $L^2(\Omega, H)$  such that this subsequence 3d-2d converges to  $u_0$  and

$$(A.2) \quad \frac{1}{|\Omega|} |u_0|_{L^2(\Omega, H)}^2 \leq \liminf_{\varepsilon \rightarrow 0} \frac{1}{|\Omega^\varepsilon|} |u^\varepsilon|_{L^2(\Omega^\varepsilon, H)}^2.$$

*Proof.* As  $u_\varepsilon$  defined by

$$(A.3) \quad u_\varepsilon(x) = u^\varepsilon(x^\varepsilon) \text{ a.e. } x \in \Omega$$

satisfies

$$(A.4) \quad \frac{1}{|\Omega^\varepsilon|} \int_{\Omega^\varepsilon} |u^\varepsilon(x^\varepsilon)|^2 dx^\varepsilon = \frac{1}{|\Omega|} \int_{\Omega} |u_\varepsilon(x)|^2 dx,$$

there exists a not relabeled subsequence such that  $u_\varepsilon$  weakly converges towards some  $u_0$  in  $L^2(\Omega, H)$  with

$$(A.5) \quad \begin{aligned} \lim_{\varepsilon \rightarrow 0} \frac{1}{|\Omega^\varepsilon|} \int_{\Omega^\varepsilon} u^\varepsilon(x^\varepsilon) \cdot \psi(x^\varepsilon) dx^\varepsilon &= \lim_{\varepsilon \rightarrow 0} \frac{1}{|\Omega|} \int_{\Omega} u_\varepsilon(x) \cdot \psi(x) dx \\ &= \frac{1}{|\Omega|} \int_{\Omega} u_0(x) \cdot \psi(x) dx, \end{aligned}$$

and consequently (A.2). □

This 3d-2d limit  $u_0$  may give accurate information on the behavior of  $u^\varepsilon$ :

**Proposition A.2.** Let  $u^\varepsilon$  be a sequence of functions in  $L^2(\Omega^\varepsilon, H)$  that 3d-2d converges to a limit  $u_0$  belonging to  $L^2(\Omega, H)$ . Assume that

$$(A.6) \quad \lim_{\varepsilon \rightarrow 0} \frac{1}{|\Omega^\varepsilon|} |u^\varepsilon|_{L^2(\Omega^\varepsilon, H)}^2 = \frac{1}{|\Omega|} |u_0|_{L^2(\Omega, H)}^2.$$

Then, for any sequence  $v^\varepsilon$  that 3d-2d converges to a limit  $v_0$  belonging to  $L^2(\Omega, H)$  we have

$$(A.7) \quad \lim_{\varepsilon \rightarrow 0} \frac{1}{|\Omega^\varepsilon|} \int_{\Omega^\varepsilon} u^\varepsilon(x^\varepsilon) \cdot v^\varepsilon(x^\varepsilon) \, dx^\varepsilon = \frac{1}{|\Omega|} \int_{\Omega} u_0(x) \cdot v_0(x) \, dx,$$

$$(A.8) \quad \lim_{\varepsilon \rightarrow 0} \frac{1}{|\Omega^\varepsilon|} \int_{\Omega^\varepsilon} |u^\varepsilon(x^\varepsilon) - u_0^\varepsilon(x^\varepsilon)|^2 \, dx^\varepsilon = 0,$$

with  $u_0^\varepsilon(x^\varepsilon) := u_0(x)$  a.e.  $x^\varepsilon \in \Omega^\varepsilon$ .

PROOF. It is an obvious consequence of (A.3), which implies that  $u_\varepsilon$  converges strongly in  $L^2(\Omega, H)$  towards  $u_0$ , while  $v_\varepsilon$  converges weakly  $L^2(\Omega, H)$  towards  $v_0$ .  $\square$

Relation (A.8) expresses that  $u_0^\varepsilon$  is rather a good approximation of  $u^\varepsilon$  in the sense that the *relative gap* in  $L^2(\Omega^\varepsilon, H)$  tends to zero, i.e.

$$\frac{|u^\varepsilon - u_0^\varepsilon|_{L^2(\Omega^\varepsilon, H)}}{|u_0^\varepsilon|_{L^2(\Omega^\varepsilon, H)}} \xrightarrow{\varepsilon \rightarrow 0} 0.$$

**Application:** A standard problem of equilibrium of a linearly elastic thin plate occupying  $\Omega^\varepsilon$  with elasticity tensor  $a^\varepsilon$  subjected to a given loading represented by a continuous linear form  $L^\varepsilon$  on  $H_{\Gamma_D}^1(\Omega^\varepsilon, \mathbb{R}^3)$  can be formulated as:

$$(A.9) \quad \begin{cases} \text{Find } u^\varepsilon \text{ in } H_{\Gamma_D}^1(\Omega^\varepsilon, \mathbb{R}^3) \text{ such that} \\ \int_{\Omega^\varepsilon} a^\varepsilon(x^\varepsilon) e^\varepsilon(u^\varepsilon) \cdot e^\varepsilon(v) \, dx^\varepsilon = L^\varepsilon(v) \quad \forall v \in H_{\Gamma_D}^1(\Omega^\varepsilon, \mathbb{R}^3). \end{cases}$$

Let  $S_\varepsilon$  be defined by  $(S_\varepsilon v)(x) = (\widehat{v}(x^\varepsilon)/\varepsilon, v_3(x^\varepsilon))$ . This immediately implies:

$$(A.10) \quad e^\varepsilon(v)(x^\varepsilon) = \varepsilon e(\varepsilon, S_\varepsilon v)(x), \quad e(\varepsilon, \cdot) = \begin{bmatrix} \widehat{e}_{\alpha\beta} & \frac{1}{\varepsilon} e_{\alpha 3} \\ \frac{1}{\varepsilon} e_{\alpha 3} & \frac{1}{\varepsilon^2} e_{33} \end{bmatrix}.$$

Now let us make the following assumption similar to (H4) for both  $a^\varepsilon$  and the loading  $(f^\varepsilon, g^\varepsilon)$ :

$$(A.11) \quad \begin{cases} a^\varepsilon(x^\varepsilon) = a(x), \text{ etc.} \\ \exists L_\varepsilon \in H_{\Gamma_D}^1(\Omega, \mathbb{R}^3)' \text{ s.t. } L^\varepsilon(v) = \varepsilon^3 L_\varepsilon(S_\varepsilon v), \\ L_\varepsilon \text{ strongly converges in } H_{\Gamma_D}^1(\Omega, \mathbb{R}^3)' \text{ towards } L. \end{cases}$$

We then get that the field

$$(A.12) \quad u_\varepsilon := S_\varepsilon(u^\varepsilon)$$

does satisfy:

$$(A.13) \quad \begin{cases} \text{Find } u_\varepsilon \text{ in } H_{\Gamma_D}^1(\Omega, \mathbb{R}^3) \text{ such that} \\ \int_{\Omega} a(x)e(\varepsilon, u_\varepsilon) \cdot e(\varepsilon, v) \, dx = L_\varepsilon(v) \quad \forall v \in H_{\Gamma_D}^1(\Omega, \mathbb{R}^3). \end{cases}$$

We can replicate the proof of Proposition 4.2 to show that there exists some  $u = (u^0, u^1)$  in  $\mathcal{U}$  such that  $e(\varepsilon, u_\varepsilon)$  strongly converges towards  $E_u := e(u^0) + \partial_3 u^1 \otimes_s e_3$  with

$$\begin{cases} u \in \mathcal{U}, \\ \int_{\Omega} aE_u \cdot E_v \, dx = L(u) \quad \forall v \in \mathcal{U}, \end{cases}$$

$$\lim_{\varepsilon \rightarrow 0} \frac{1}{\varepsilon^3} \int_{\Omega^\varepsilon} a(e^\varepsilon(u^\varepsilon) - E_u^\varepsilon) \cdot (e^\varepsilon(u^\varepsilon) - E_u^\varepsilon) \, dx^\varepsilon = 0, \quad E_u^\varepsilon(x^\varepsilon) := \varepsilon E_u(x),$$

that is to say  $\varepsilon^{-1}e^\varepsilon(u^\varepsilon)$  3d-2d converges towards  $E_u$  and the strain of the real field  $u^\varepsilon$  in the domain  $\Omega^\varepsilon$  is close to  $E_u^\varepsilon$  in the sense that the *relative* energetic gap tends to zero, which is the only significant notion as the energy of  $u^\varepsilon$  tends to zero!

#### References

- [1] *G. Allaire*: Homogenization and two-scale convergence. *SIAM J. Math. Anal.* *23* (1992), 1482–1518. [zbl](#) [MR](#) [doi](#)
- [2] *A. Bobrowski*: Convergence of One-Parameter Operator Semi-Groups in Models of Mathematical Biology and Elsewhere. *New Mathematical Monographs* 30. Cambridge University Press, Cambridge. [zbl](#) [MR](#) [doi](#)
- [3] *H. Brézis*: Opérateurs maximaux monotones et semi-groupes de contractions dans les espaces de Hilbert. *North-Holland Mathematics Studies* 5. North-Holland, Amsterdam, 1973. (In French.) [zbl](#) [MR](#) [doi](#)
- [4] *P. G. Ciarlet*: *Mathematical Elasticity. Vol. 2. Theory of Plates.* *Studies in Mathematics and Its Applications* 27. North Holland, Amsterdam, 1997. [zbl](#) [MR](#)
- [5] *G. Francfort, D. Leguillon, P. Suquet*: Homogénéisation de milieux viscoélastiques linéaires de Kelvin-Voigt. *C. R. Acad. Sci., Paris, Sér. I* *296* (1983), 287–290. (In French.) [zbl](#) [MR](#)
- [6] *A. Gaudiello, R. Monneau, J. Mossino, F. Murat, A. Sili*: Junction of elastic plates and beams. *ESAIM, Control Optim. Calc. Var.* *13* (2007), 419–457. [zbl](#) [MR](#) [doi](#)
- [7] *O. Iosifescu, C. Licht*: Transient response of a thin linearly elastic plate with Norton or Tresca friction. *Asymptotic Anal.* *128* (2022), 555–570. [zbl](#) [MR](#) [doi](#)
- [8] *O. Iosifescu, C. Licht, G. Michaille*: Nonlinear boundary conditions in Kirchhoff-Love plate theory. *J. Elasticity* *96* (2009), 57–79. [zbl](#) [MR](#) [doi](#)
- [9] *C. Licht*: Thin linearly viscoelastic Kelvin-Voigt plates. *C. R., Méc., Acad. Sci. Paris* *341* (2013), 697–700. [doi](#)
- [10] *C. Licht, T. Weller*: Approximation of semi-groups in the sense of Trotter and asymptotic mathematical modeling in physics of continuous media. *Discrete Contin. Dyn. Syst., Ser. S* *12* (2019), 1709–1741. [zbl](#) [MR](#) [doi](#)
- [11] *C. Licht, T. Weller*: Asymptotic analysis of a thin linearly elastic plate equipped with a periodic distribution of stiffeners. *C. R., Méc., Acad. Sci. Paris* *347* (2019), 555–560. [doi](#)



- [12] *S. Migórski, A. Ochal, M. Sofonea*: Analysis of a frictional contact problem for viscoelastic materials with long memory. *Discrete Contin. Dyn. Syst., Ser. B* *15* (2011), 687–705. [zbl](#) [MR](#) [doi](#)
- [13] *G.Nguetseng*: A general convergence result for a functional related to the theory of homogenization. *SIAM J. Math. Anal.* *20* (1989), 608–623. [zbl](#) [MR](#) [doi](#)
- [14] *Y. Terapabkajorned, S. Orankitjaroen, C. Licht*: Asymptotic model of linearly viscoelastic Kelvin-Voigt type plates via Trotter theory. *Adv. Difference Equ.* *2019* (2019), Article ID 186, 9 pages. [zbl](#) [MR](#) [doi](#)
- [15] *H. F. Trotter*: Approximation of semi-groups of operators. *Pac. J. Math.* *8* (1958), 887–919. [zbl](#) [MR](#) [doi](#)
- [16] *V. V. Zhikov, S. E. Pastukhova*: On the Trotter-Kato theorem in a variable space. *Funct. Anal. Appl.* *41* (2007), 264–270. [zbl](#) [MR](#) [doi](#)

*Authors' addresses:* *Yotsawat Terapabkajorned*, Department of Mathematics, Faculty of Science, Mahidol University, 272 Rama VI Road, Thung Phayathai, Ratchathewi, Bangkok 10400, Thailand, e-mail: [ongyosawat@gmail.com](mailto:ongyosawat@gmail.com); *Somsak Orankitjaroen*, Department of Mathematics, Faculty of Science, Mahidol University, 272 Rama VI Road, Thung Phayathai, Ratchathewi, Bangkok 10400, Thailand; Centre of Excellence in Mathematics, MHESI, 272 Rama VI Road, Faculty of Science, Mahidol University, Bangkok 10400, Thailand, e-mail: [somsak.ora@mahidol.ac.th](mailto:somsak.ora@mahidol.ac.th); *Christian Licht*, Department of Mathematics, Faculty of Science, Mahidol University, 272 Rama VI Road, Thung Phayathai, Ratchathewi, Bangkok 10400, Thailand; Centre of Excellence in Mathematics, MHESI, 272 Rama VI Road, Faculty of Science, Mahidol University, Bangkok 10400, Thailand; LMGC – UMR 5508, Université de Montpellier, cc048, 163 rue Auguste Broussonnet, 34090 Montpellier, France, e-mail: [christian.licht@umontpellier.fr](mailto:christian.licht@umontpellier.fr); *Thibaut Weller* (corresponding author), LMGC – UMR 5508, Université de Montpellier, cc048, 163 rue Auguste Broussonnet, 34090 Montpellier, France, e-mail: [thibaut.weller@umontpellier.fr](mailto:thibaut.weller@umontpellier.fr).