



HAL
open science

Broadcast Channel Coding: Algorithmic Aspects and Non-Signaling Assistance

Omar Fawzi, Paul Fermé

► **To cite this version:**

Omar Fawzi, Paul Fermé. Broadcast Channel Coding: Algorithmic Aspects and Non-Signaling Assistance. 2023. hal-04232851

HAL Id: hal-04232851

<https://hal.science/hal-04232851>

Preprint submitted on 9 Oct 2023

HAL is a multi-disciplinary open access archive for the deposit and dissemination of scientific research documents, whether they are published or not. The documents may come from teaching and research institutions in France or abroad, or from public or private research centers.

L'archive ouverte pluridisciplinaire **HAL**, est destinée au dépôt et à la diffusion de documents scientifiques de niveau recherche, publiés ou non, émanant des établissements d'enseignement et de recherche français ou étrangers, des laboratoires publics ou privés.



Distributed under a Creative Commons Attribution 4.0 International License

Broadcast Channel Coding: Algorithmic Aspects and Non-Signaling Assistance

Omar Fawzi* Paul Fermé†

Abstract

We address the problem of coding for classical broadcast channels, which entails maximizing the success probability that can be achieved by sending a fixed number of messages over a broadcast channel. For point-to-point channels, Barman and Fawzi found in [1] a $(1-e^{-1})$ -approximation algorithm running in polynomial time, and showed that it is NP-hard to achieve a strictly better approximation ratio. Furthermore, these algorithmic results were at the core of the limitations they established on the power of non-signaling assistance for point-to-point channels. It is natural to ask if similar results hold for broadcast channels, exploiting links between approximation algorithms of the channel coding problem and the non-signaling assisted capacity region.

In this work, we make several contributions on algorithmic aspects and non-signaling assisted capacity regions of broadcast channels. For the class of deterministic broadcast channels, we describe a $(1-e^{-1})^2$ -approximation algorithm running in polynomial time, and we show that the capacity region for that class is the same with or without non-signaling assistance. Finally, we show that in the value query model, we cannot achieve a better approximation ratio than $\Omega\left(\frac{1}{\sqrt{m}}\right)$ in polynomial time for the general broadcast channel coding problem, with m the size of one of the outputs of the channel.

1 Introduction

Broadcast channels, introduced by Cover in [2], describe the simple network communication setting where one sender aims to transmit individual messages to two receivers. Contrary to point-to-point channels [3] or multiple-access channels [4, 5], the capacity region of broadcast channels is known only for particular classes such as the degraded [6, 7, 8], deterministic [9, 10] and semi-deterministic [11]. Only inner bounds [12, 13, 14] and outer bounds [15, 14, 16, 17] on the capacity region are known in the general setting.

On the one hand, from the point of view of quantum information, it is natural to ask whether additional resources, such as quantum entanglement or more generally non-signaling correlations between the parties, changes the capacity region. A non-signaling correlation is a multipartite input-output box shared between parties that, as the name suggests, cannot by itself be used to send information between parties. However, non-signaling correlations such as the ones generated by measurements of entangled quantum particles, can provide an advantage for various information processing tasks and nonlocal games. The study of such correlations has given rise to the quantum information area known as nonlocality [18]. For example, in the context of channel coding, there exists classical point-to-point channels for which quantum entanglement between the sender and the receiver can increase the optimal success probability for sending one bit of information with a single use of the channel [19, 1]. However, for classical point-to-point channels, entanglement [20, 21] and even more generally non-signaling correlations [22] do not change the capacity of the channel.

*Univ Lyon, ENS Lyon, UCBL, CNRS, Inria, LIP, F-69342, Lyon Cedex 07, France. omar.fawzi@ens-lyon.fr

†Univ Lyon, ENS Lyon, UCBL, CNRS, Inria, LIP, F-69342, Lyon Cedex 07, France. paul.ferme@ens-lyon.fr

In the network setting, the behavior is different. Quek and Shor showed in [23] the existence of two-sender two-receiver interference channels with gaps between their classical, quantum-entanglement assisted and non-signaling assisted capacity regions. Following this result, Leditzky et al. [24, 25] showed that quantum entanglement shared between the two senders of a multiple access channel can strictly enlarge the capacity region. More specifically, a general investigation of non-signaling resources on multiple-access channel coding was done in [26, 27], where it was notably proved that non-signaling advantage occurs even for a simple textbook multiple-access channel: the binary adder channel. However, the influence of nonlocal resources on broadcast channels has been comparably less studied. We only know that quantum entanglement shared between decoders does not change the capacity region [28].

On the other hand, from an algorithmic point of view, an important question is the complexity of the channel coding problem, which entails maximizing the success probability that can be achieved by sending a fixed number of messages over a channel. However, as solving exactly this problem is NP-hard, a natural question that arises is its approximability. For point-to-point channels, Barman and Fawzi found in [1] a $(1 - e^{-1})$ -approximation algorithm running in polynomial time. They showed that it is NP-hard to approximate the channel coding problem in polynomial time for any strictly better ratio. For ℓ -list-decoding, where the decoder is allowed to output a list of ℓ guesses, a polynomial-time approximation algorithm achieving a $1 - \frac{\ell^\ell e^{-\ell}}{\ell!}$ ratio was found in [29], and it was shown to be NP-hard to do better in [30]. For multiple-access channel coding, the complexity of the problem can be linked to the bipartite densest subgraph problem [31, 32], which cannot be approximated within any constant ratio under a complexity hypothesis on random k -SAT formulas [33]. However, the approximability of broadcast channel coding has not been addressed in the literature.

In the point-to-point scenario studied in [1], the existence of a constant-ratio approximation algorithm is linked to the equality of the capacity regions with and without non-signaling assistance. Indeed, giving non-signaling assistance to the channel coding problem turns it into a linear program, thus computable in polynomial time. In fact, it is equal to its natural linear relaxation, which is a common strategy towards approximating an integer linear program. Showing that this approximation strategy guarantees a constant ratio is the key ingredient in proving the equality of the capacity regions with and without non-signaling assistance. This raises the following questions on broadcast channels: Does the capacity region of the broadcast channel change when non-signaling resources between parties are allowed? What is the best approximability ratio of the broadcast channel coding problem? How those two questions are related?

Contributions As a first result, we prove that the sum success probabilities of the broadcast channel coding problem are the same with and without non-signaling assistance between decoders; see Theorem 4.2. This strengthens a result by [28] establishing that entanglement between the decoders does not change the capacity region.

The main focus of this paper is to study the influence of sharing a non-signaling resource between the three parties. Our main result shows that for the class of deterministic broadcast channels, non-signaling resources shared between the three parties does not change the capacity region; see Theorem 5.8 and Corollary 5.9. In order to prove this result, we consider the algorithmic problem of optimal channel coding for a deterministic broadcast channel. For this problem, we describe a $(1 - e^{-1})^2$ -approximation algorithm running in polynomial time. This is achieved through a graph interpretation of the problem, where one aims at partitioning a bipartite graph into k_1 and k_2 parts, such that the resulting quotient graph is the densest possible; see Proposition 5.5 and Theorem 5.6. To prove our result on the limitations of non-signaling assistance for deterministic broadcast channels, we use the same ideas as the ones involved in the analysis of the approximation algorithm.

As far as hardness is concerned, we consider the subproblem of broadcast channel coding where the number of messages one decoder is responsible of is maximum. This subproblem can be interpreted as a social welfare maximization problem. In the theory of fair division [34, 35], social welfare maximization entails partitioning a set of goods among agents in order to maximize the sum of their utilities. The social welfare problem has been extensively studied through a black box approach [36], which led to a precise analysis of achievable approximation ratio as well as hardness results [37, 38], depending on the class of utility functions considered and the type of black box access to them. We refine the hardness result for the class of fractionally sub-additive utility functions to the subclass coming from

the broadcast channel coding subproblem interpretation. Specifically, we show that in the value query model, we cannot achieve a better approximation ratio than $\Omega\left(\frac{1}{\sqrt{m}}\right)$ in polynomial time, with m the size of one of the outputs of the channel: see Theorem 6.5. This gives some evidence that the broadcast channel coding problem might be hard to approximate. Following the previous discussion on the links between approximation algorithms and non-signaling capacity regions, this hardness evidence is a first step towards showing that sharing a non-signaling resource between the three parties of a broadcast channel can enlarge its capacity region.

Organization In Section 2, we introduce some basic definitions as well as useful notions that will be used throughout this work. In Section 3, we define precisely the different versions of the broadcast channel coding problem depending on the choice of objective value, and show that they all lead to the same capacity region. In Section 4, we define the different non-signaling assisted versions of the broadcast channel coding problem. In particular, we show that the sum success probabilities with and without non-signaling assistance shared between decoders are the same, and that it implies that the related capacity regions are the same. In Section 5, we address both algorithmic aspects and capacity considerations of deterministic broadcast channels. Specifically, we describe a $(1 - e^{-1})^2$ -approximation algorithm running in polynomial time for that class, and we show that the capacity region for that class is the same with or without non-signaling assistance. Finally, in Section 6, we show that in the value query model, we cannot achieve a better approximation ratio than $\Omega\left(\frac{1}{\sqrt{m}}\right)$ in polynomial time for the general broadcast channel coding problem, with m the size of one of the outputs of the channel.

2 Preliminaries

2.1 Broadcast Channels

Formally, a broadcast channel is given by a conditional probability distribution on input \mathcal{X} and two outputs \mathcal{Y}_1 and \mathcal{Y}_2 , so $W := (W(y_1, y_2|x))_{y_1 \in \mathcal{Y}_1, y_2 \in \mathcal{Y}_2, x \in \mathcal{X}}$, with $W(y_1 y_2|x) \geq 0$ and such that $\sum_{y_1 \in \mathcal{Y}_1, y_2 \in \mathcal{Y}_2} W(y_1 y_2|x) = 1$. We define its marginals W_1 and W_2 respectively by $W_1(y_1|x) := \sum_{y_2 \in \mathcal{Y}_2} W(y_1 y_2|x)$ and $W_2(y_2|x) := \sum_{y_1 \in \mathcal{Y}_1} W(y_1 y_2|x)$. We will denote such a broadcast channel by $W : \mathcal{X} \rightarrow \mathcal{Y}_1 \times \mathcal{Y}_2$. The tensor product of two broadcast channels $W : \mathcal{X} \rightarrow \mathcal{Y}_1 \times \mathcal{Y}_2$ and $W' : \mathcal{X}' \rightarrow \mathcal{Y}'_1 \times \mathcal{Y}'_2$ is denoted by $W \otimes W' : \mathcal{X} \times \mathcal{X}' \rightarrow (\mathcal{Y}_1 \times \mathcal{Y}'_1) \times (\mathcal{Y}_2 \times \mathcal{Y}'_2)$ and defined by $(W \otimes W')(y_1 y'_1 y_2 y'_2 | x x') := W(y_1 y_2 | x) \cdot W'(y'_1 y'_2 | x')$. We define $W^{\otimes n}(y_1^n y_2^n | x^n) := \prod_{i=1}^n W(y_{1,i} y_{2,i} | x_i)$, for $y_1^n := y_{1,1} \dots y_{1,n} \in \mathcal{Y}_1^n$ and $y_2^n := y_{2,1} \dots y_{2,n} \in \mathcal{Y}_2^n$ and $x^n := x_1 \dots x_n \in \mathcal{X}^n$. We will use the notation $[k] := \{1, \dots, k\}$.

2.2 Capacity Regions

Given a notion of success probability $S(W, k_1, k_2)$, that is to say the probability of correctly encoding and decoding k_1 and k_2 messages for the channel W , we can define the related capacity region.

Definition 2.1 (Capacity Region $\mathcal{C}[S](W)$ for a success probability $S(W, k_1, k_2)$). A rate pair (R_1, R_2) is S -achievable (for the channel W) if:

$$\lim_{n \rightarrow +\infty} S(W^{\otimes n}, \lceil 2^{R_1 n} \rceil, \lceil 2^{R_2 n} \rceil) = 1.$$

We define the S -capacity region $\mathcal{C}[S](W)$ as the closure of the set of all achievable rate pairs (for the channel W).

2.3 Negatively Associated Random Variables

We present a weaker notion of independence for random variables which is called negative association as introduced in [39], for which the Chernoff-Hoeffding bounds still hold.

Definition 2.2. Random variables X_1, \dots, X_n are said to be negatively associated if for every pair of disjoint subsets I, J of $[n]$ and (coordinate-wise) increasing functions f, g , we have:

$$\mathbb{E}[f(\{X_i : i \in I\}) \cdot g(\{X_i : i \in J\})] \leq \mathbb{E}[f(\{X_i : i \in I\})] \cdot \mathbb{E}[g(\{X_i : i \in J\})] .$$

Proposition 2.3 (Property P₁ of [39]). A pair of random variable X, Y is negatively associated if and only if:

$$\forall x \in \mathcal{X}, \forall y \in \mathcal{Y}, P_{XY}(x, y) \leq P_X(x)P_Y(y) .$$

Proposition 2.4 (Property P₄ of [39]). A subset of two or more negatively associated random variables is negatively associated.

Proposition 2.5 (Property P₅ of [39]). A set of independent random variables is negatively associated.

Proposition 2.6 (Property P₆ of [39]). Increasing functions defined on disjoint subsets of a set of negatively associated random variables are negatively associated.

Proposition 2.7 (Property P₇ of [39]). The union of independent sets of negatively associated random variables is negatively associated.

Definition 2.8 (Permutation Distribution). Let $x = (x_1, \dots, x_k) \in \mathbb{R}^k$. A permutation distribution is the joint distribution of the vector $X = (X_1, \dots, X_k)$ which takes as values all $k!$ permutations of x with equal probabilities, each being $\frac{1}{k!}$.

Proposition 2.9 (Theorem 2.11 of [39]). A permutation distribution is negatively associated.

Proposition 2.10 (Chernoff-Hoeffding bound). Let X_1, \dots, X_n be negatively associated Bernoulli random variables of parameter p . Then for $0 < \varepsilon \leq \frac{1}{2}$:

$$\mathbb{P}\left(\frac{1}{n} \sum_{i=1}^n X_i > (1 + \varepsilon)p\right) \leq e^{-\frac{pn\varepsilon^2}{4}} .$$

Proof. Usual proofs of the Chernoff-Hoeffding bound work in the same way with negatively associated variables as pointed out by [40]. So, one obtain as in the original proof (Theorem 1 of [41]) that:

$$\mathbb{P}\left(\frac{1}{n} \sum_{i=1}^n X_i > (1 + \varepsilon)p\right) \leq e^{-D((1+\varepsilon)p||p)n} ,$$

with $D(x||y) := x \ln\left(\frac{x}{y}\right) + (1-x) \ln\left(\frac{1-x}{1-y}\right)$ the Kullback-Leibler divergence between Bernoulli distributed random variables with parameters x and y . As $D((1+\varepsilon)p||p) \geq \frac{\varepsilon^2 p}{4}$ for $0 < \varepsilon < \frac{1}{2}$, we recover the expected bound. \square

3 Broadcast Channel Coding

3.1 Broadcast Channels

The coding problem for a broadcast channel $W : \mathcal{X} \rightarrow \mathcal{Y}_1 \times \mathcal{Y}_2$ can be stated in the following way. We want to encode a pair of messages belonging to $[k_1] \times [k_2]$ into \mathcal{X} . The pair is given as input to W , which results in two random outputs in \mathcal{Y}_1 and \mathcal{Y}_2 . From the output in \mathcal{Y}_1 (resp. \mathcal{Y}_2), we want to decode back the original message in $[k_1]$ (resp. $[k_2]$). We will call $e : [k_1] \times [k_2] \rightarrow \mathcal{X}$ the encoder, $d_1 : \mathcal{Y}_1 \rightarrow [k_1]$ the first decoder and $d_2 : \mathcal{Y}_2 \rightarrow [k_2]$ the second decoder. The scenario is depicted in Figure 1.

We will call $p_1(W, e, d_1)$ (resp. $p_2(W, e, d_2)$) the probability of successfully decoding the first (resp. second) message, i.e. that $j_1 = i_1$ (resp. $j_2 = i_2$), given that the encoder is e and the decoder is d_1 (resp. d_2). We will also consider $p(W, e, d_1, d_2)$, the probability of successfully decoding both messages, i.e. that $j_1 = i_1$ and $j_2 = i_2$, given that the encoder is e and the decoders are d_1, d_2 .

We aim to find the best encoder and decoders according to some figure of merit. However, to do so, we need a one-dimensional real-valued objective to optimize. This leads to two different quantities.

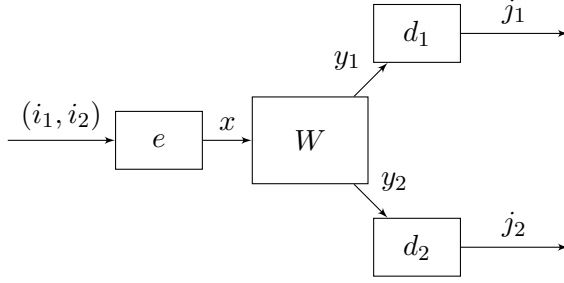

Figure 1: Coding for a broadcast channel W .

3.2 The Sum Success Probability

We will focus first on maximizing $\frac{p_1(W, e, d_1) + p_2(W, e, d_2)}{2}$ over all encoders e and decoders d_1, d_2 . We will call $S_{\text{sum}}(W, k_1, k_2)$ the resulting maximum sum probability of successfully encoding and decoding the messages through W , given that the input pair of messages is taken uniformly in $[k_1] \times [k_2]$. $S_{\text{sum}}(W, k_1, k_2)$ is the solution of the following optimization program:

$$\begin{aligned}
& \underset{e, d_1, d_2}{\text{maximize}} && \frac{1}{k_1 k_2} \sum_{i_1, i_2, x, y_1, y_2} W(y_1 y_2 | x) e(x | i_1 i_2) \frac{d_1(i_1 | y_1) + d_2(i_2 | y_2)}{2} \\
& \text{subject to} && \sum_{x \in \mathcal{X}} e(x | i_1 i_2) = 1, \forall i_1 \in [k_1], i_2 \in [k_2] \\
& && \sum_{j_1 \in [k_1]} d_1(j_1 | y_1) = 1, \forall y_1 \in \mathcal{Y}_1 \\
& && \sum_{j_2 \in [k_2]} d_2(j_2 | y_2) = 1, \forall y_2 \in \mathcal{Y}_2 \\
& && e(x | i_1 i_2), d_1(j_1 | y_1), d_2(j_2 | y_2) \geq 0
\end{aligned} \tag{1}$$

Proof. One should note that we allow in fact non-deterministic encoders and decoders for generality reasons, although the value of the program is not changed as it is convex. Besides that remark, let us name $I_1, I_2, J_1, J_2, X, Y_1, Y_2$ the random variables corresponding to $i_1, i_2, j_1, j_2, x, y_1, y_2$ in the coding and decoding process. Then, given e, d_1, d_2 and W , the objective value of the previous program comes from:

$$\begin{aligned}
p_1(W, e, d_1) &= \mathbb{P}(J_1 = I_1) = \frac{1}{k_1 k_2} \sum_{i_1, i_2} \mathbb{P}(J_1 = i_1 | I_1 = i_1, I_2 = i_2) \\
&= \frac{1}{k_1 k_2} \sum_{i_1, i_2, x} e(x | i_1 i_2) \mathbb{P}(J_1 = i_1 | i_1, i_2, X = x) \\
&= \frac{1}{k_1 k_2} \sum_{i_1, i_2, x, y_1, y_2} W(y_1 y_2 | x) e(x | i_1 i_2) \mathbb{P}(J_1 = i_1 | i_1, i_2, x, Y_1 = y_1, Y_2 = y_2) \\
&= \frac{1}{k_1 k_2} \sum_{i_1, i_2, x, y_1, y_2} W(y_1 y_2 | x) e(x | i_1 i_2) d_1(i_1 | y_1),
\end{aligned} \tag{2}$$

and symmetrically for $p_2(W, e, d_2)$, which leads to the announced objective value. \square

One can rewrite this optimization program in a more convenient way, proving that $S_{\text{sum}}(W, k_1, k_2)$ depends only on the marginals of W :

Proposition 3.1.

$$\begin{aligned}
S_{\text{sum}}(W, k_1, k_2) = & \underset{e, d_1, d_2}{\text{maximize}} \quad \frac{1}{2k_1k_2} \sum_{i_1, x, y_1} W_1(y_1|x) d_1(i_1|y_1) \sum_{i_2} e(x|i_1i_2) \\
& + \frac{1}{2k_1k_2} \sum_{i_2, x, y_2} W_2(y_2|x) d_2(i_2|y_2) \sum_{i_1} e(x|i_1i_2) \\
\text{subject to} & \sum_{x \in \mathcal{X}} e(x|i_1i_2) = 1, \forall i_1 \in [k_1], i_2 \in [k_2] \\
& \sum_{j_1 \in [k_1]} d_1(j_1|y_1) = 1, \forall y_1 \in \mathcal{Y}_1 \\
& \sum_{j_2 \in [k_2]} d_2(j_2|y_2) = 1, \forall y_2 \in \mathcal{Y}_2 \\
& e(x|i_1i_2), d_1(j_1|y_1), d_2(j_2|y_2) \geq 0
\end{aligned} \tag{3}$$

Proof. It follows from the definitions $W_1(y_1|x) := \sum_{y_2} W(y_1y_2|x)$ and $W_2(y_2|x) := \sum_{y_1} W(y_1y_2|x)$. \square

3.3 The Joint Success Probability

We will now focus on maximizing $p(W, e, d_1, d_2)$ over all encoders e and decoders d_1, d_2 . We will call $S(W, k_1, k_2)$ the resulting maximum probability of successfully encoding and decoding the messages through W , given that the input pair of messages is taken uniformly in $[k_1] \times [k_2]$. $S(W, k_1, k_2)$ is the solution of the following optimization program:

$$\begin{aligned}
S(W, k_1, k_2) := & \underset{e, d_1, d_2}{\text{maximize}} \quad \frac{1}{k_1k_2} \sum_{i_1, i_2, x, y_1, y_2} W(y_1y_2|x) e(x|i_1i_2) d_1(i_1|y_1) d_2(i_2|y_2) \\
\text{subject to} & \sum_{x \in \mathcal{X}} e(x|i_1i_2) = 1, \forall i_1 \in [k_1], i_2 \in [k_2] \\
& \sum_{j_1 \in [k_1]} d_1(j_1|y_1) = 1, \forall y_1 \in \mathcal{Y}_1 \\
& \sum_{j_2 \in [k_2]} d_2(j_2|y_2) = 1, \forall y_2 \in \mathcal{Y}_2 \\
& e(x|i_1i_2), d_1(j_1|y_1), d_2(j_2|y_2) \geq 0
\end{aligned} \tag{4}$$

The proof is the same as in the sum probability scenario. We define the (resp. sum) capacity region using Definition 2.1 by $\mathcal{C}(W) := \mathcal{C}[S](W)$ (resp. $\mathcal{C}_{\text{sum}}(W) := \mathcal{C}[S_{\text{sum}}](W)$).

The objective values of those two optimization programs are not the same, but $S(W, k_1, k_2)$ and $S_{\text{sum}}(W, k_1, k_2)$ still characterize the same capacity region [42]:

Proposition 3.2. For any broadcast channel W , $\mathcal{C}(W) = \mathcal{C}_{\text{sum}}(W)$.

Proof. Let us focus on error probabilities rather than success ones. Call them respectively $E(W, k_1, k_2) := 1 - S(W, k_1, k_2)$ and $E_{\text{sum}}(W, k_1, k_2) := 1 - S_{\text{sum}}(W, k_1, k_2)$. Let us fix a solution e, d_1, d_2 of the optimization program computing $S(W, k_1, k_2)$. Let us remark first that:

$$\sum_{i_1, i_2, x, y_1, y_2} W(y_1y_2|x) e(x|i_1i_2) = k_1k_2,$$

thus, the value of the maximum error for those encoder and decoders is:

$$\begin{aligned}
\mathbb{E}(W, k_1, k_2, e, d_1, d_2) &:= 1 - \frac{1}{k_1 k_2} \left(\sum_{i_1, i_2, x, y_1, y_2} W(y_1 y_2 | x) e(x | i_1 i_2) d_1(i_1 | y_1) d_2(i_2 | y_2) \right) \\
&= \frac{1}{k_1 k_2} \sum_{i_1, i_2, x, y_1, y_2} W(y_1 y_2 | x) e(x | i_1 i_2) \\
&\quad - \frac{1}{k_1 k_2} \sum_{i_1, i_2, x, y_1, y_2} W(y_1 y_2 | x) e(x | i_1 i_2) d_1(i_1 | y_1) d_2(i_2 | y_2) \\
&= \frac{1}{k_1 k_2} \left(\sum_{i_1, i_2, x, y_1, y_2} W(y_1 y_2 | x) e(x | i_1 i_2) [1 - d_1(i_1 | y_1) d_2(i_2 | y_2)] \right).
\end{aligned} \tag{5}$$

Similarly, the value of the sum error $\mathbb{E}_{\text{sum}}(W, k_1, k_2, e, d_1, d_2)$ is equal to:

$$\begin{aligned}
&1 - \frac{1}{k_1 k_2} \left(\sum_{i_1, i_2, x, y_1, y_2} W(y_1 y_2 | x) e(x | i_1 i_2) \frac{d_1(i_1 | y_1) + d_2(i_2 | y_2)}{2} \right) \\
&= \frac{1}{k_1 k_2} \left(\sum_{i_1, i_2, x, y_1, y_2} W(y_1 y_2) e(x | i_1 i_2) \left[1 - \frac{d_1(i_1 | y_1) + d_2(i_2 | y_2)}{2} \right] \right).
\end{aligned} \tag{6}$$

However, for $x, y \in [0, 1]$, we have that:

$$1 - xy \geq \max(1 - x, 1 - y) \geq 1 - \frac{x + y}{2},$$

and:

$$1 - xy \leq (1 - x) + (1 - y) = 2 \left(1 - \frac{x + y}{2} \right).$$

This means that, for all e, d_1, d_2 , we have:

$$\mathbb{E}_{\text{sum}}(W, k_1, k_2, e, d_1, d_2) \leq \mathbb{E}(W, k_1, k_2, e, d_1, d_2) \leq 2\mathbb{E}_{\text{sum}}(W, k_1, k_2, e, d_1, d_2),$$

so, maximizing over all e, d_1, d_2 , we get:

$$\mathbb{E}_{\text{sum}}(W, k_1, k_2) \leq \mathbb{E}(W, k_1, k_2) \leq 2\mathbb{E}_{\text{sum}}(W, k_1, k_2).$$

Thus, up to a multiplicative factor 2, the error is the same. In particular, when one of those errors tends to zero, the other one tends to zero as well. This implies that the capacity regions are the same. \square

4 Non-Signaling Assistance

In this section, we will consider the broadcast channel coding problem with additional resources, in order to determine how these resources affect its success probabilities as well as the capacity regions that can be defined from them.

4.1 Non-Signaling Assistance Between Decoders

Here, we consider the case where the receivers are given non-signaling assistance. This resource, which is a theoretical but easier to manipulate generalization of quantum entanglement, can be characterized

as follows. A non-signaling box $d(j_1 j_2 | y_1 y_2)$ is any joint conditional probability distribution such that the marginal from one party is independent of the other party's input, i.e. we have:

$$\begin{aligned} \forall j_1, y_1, y_2, y'_2, \quad \sum_{j_2} d(j_1 j_2 | y_1 y_2) &= \sum_{j_1} d(j_1 j_2 | y_1 y'_2) , \\ \forall j_2, y_1, y_2, y'_1, \quad \sum_{j_1} d(j_1 j_2 | y_1 y_2) &= \sum_{j_1} d(j_1 j_2 | y'_1 y_2) . \end{aligned} \quad (7)$$

Thus, when receivers are given non-signaling assistance, the product $d_1(j_1 | y_1) d_2(j_2 | y_2)$ is replaced by the non-signaling box $d(j_1 j_2 | y_1 y_2)$. Thus, we define the joint and sum success probabilities $S^{\text{NS}_{\text{dec}}}(W, k_1, k_2)$ (resp. $S_{\text{sum}}^{\text{NS}_{\text{dec}}}(W, k_1, k_2)$) by:

$$\begin{aligned} & \text{maximize}_{e, d_1, d_2} \quad \frac{1}{k_1 k_2} \sum_{i_1, i_2, x, y_1, y_2} W(y_1 y_2 | x) e(x | i_1 i_2) d(i_1 i_2 | y_1 y_2) \\ \left(\text{resp.} \quad \text{maximize}_{e, d_1, d_2} \quad \frac{1}{2k_1 k_2} \sum_{i_1, i_2, x, y_1, y_2} W(y_1 y_2 | x) e(x | i_1 i_2) \sum_{j_2} d(i_1 j_2 | y_1 y_2) \right. \\ & \quad \left. + \frac{1}{2k_1 k_2} \sum_{i_1, i_2, x, y_1, y_2} W(y_1 y_2 | x) e(x | i_1 i_2) \sum_{j_1} d(j_1 i_2 | y_1 y_2) \right) \\ \text{subject to} \quad & \sum_x e(x | i_1 i_2) = 1 \\ & \sum_{j_2} d(j_1 j_2 | y_1 y_2) = \sum_{j_1} d(j_1 j_2 | y_1 y'_2) \\ & \sum_{j_1} d(j_1 j_2 | y_1 y_2) = \sum_{j_1} d(j_1 j_2 | y'_1 y_2) \\ & \sum_{j_1, j_2} d(j_1 j_2 | y_1 y_2) = 1 \\ & e(x | i_1 i_2), d(j_1 j_2 | y_1 y_2) \geq 0 \end{aligned} \quad (8)$$

The (resp. sum) capacity region with non-signaling assistance between decoders is defined using Definition 2.1 by $\mathcal{C}^{\text{NS}_{\text{dec}}}(W) := \mathcal{C}[\text{S}^{\text{NS}_{\text{dec}}}] (W)$ (resp. $\mathcal{C}_{\text{sum}}^{\text{NS}_{\text{dec}}}(W) := \mathcal{C}[\text{S}_{\text{sum}}^{\text{NS}_{\text{dec}}}] (W)$).

We will now show that sum and joint capacity regions with non-signaling assistance between decoders are the same.

Proposition 4.1. For any broadcast channel W , $\mathcal{C}_{\text{sum}}^{\text{NS}_{\text{dec}}}(W) = \mathcal{C}^{\text{NS}_{\text{dec}}}(W)$.

Proof. Given an encoder e and a non-signaling decoding box d , the maximum success probability of encoding and decoding correctly with those is given by:

$$S^{\text{NS}_{\text{dec}}}(W, k_1, k_2, e, d) := \frac{1}{k_1 k_2} \sum_{i_1, i_2, x, y_1, y_2} W(y_1 y_2 | x) e(x | i_1 i_2) d(i_1 i_2 | y_1 y_2) .$$

This should be compared to the sum success probability $S_{\text{sum}}^{\text{NS}_{\text{dec}}}(W, k_1, k_2, e, d)$ of encoding and decoding correctly with those:

$$\frac{1}{k_1 k_2} \sum_{i_1, i_2, x, y_1, y_2} W(y_1 y_2 | x) e(x | i_1 i_2) \left[\frac{\sum_{j_2} d(i_1 j_2 | y_1 y_2) + \sum_{j_1} d(j_1 i_2 | y_1 y_2)}{2} \right] .$$

Similarly to what was done in Proposition 3.2, we focus on error probabilities rather than success probabilities. This leads again to:

$$E^{\text{NS}_{\text{dec}}}(W, k_1, k_2, e, d) = \frac{1}{k_1 k_2} \sum_{i_1, i_2, x, y_1, y_2} W(y_1 y_2 | x) e(x | i_1 i_2) [1 - d(i_1 i_2 | y_1 y_2)] ,$$

and $E_{\text{sum}}^{\text{NS}_{\text{dec}}}(W, k_1, k_2, e, d)$ equal to:

$$\frac{1}{k_1 k_2} \sum_{i_1, i_2, x, y_1, y_2} W(y_1 y_2 | x) e(x | i_1 i_2) \left[\frac{1 - \sum_{j_2} d(i_1 j_2 | y_1 y_2)}{2} + \frac{1 - \sum_{j_1} d(j_1 i_2 | y_1 y_2)}{2} \right].$$

But we have that:

$$\begin{aligned} 1 - d(i_1 i_2 | y_1 y_2) &\geq \max \left(1 - \sum_{j_2} d(i_1 j_2 | y_1 y_2), 1 - \sum_{j_1} d(j_1 i_2 | y_1 y_2) \right) \\ &\geq \frac{1 - \sum_{j_2} d(i_1 j_2 | y_1 y_2)}{2} + \frac{1 - \sum_{j_1} d(j_1 i_2 | y_1 y_2)}{2}, \end{aligned} \quad (9)$$

since $d(j_1 j_2 | y_1 y_2) \in [0, 1]$, and we have that:

$$\begin{aligned} &1 - \sum_{j_2} d(i_1 j_2 | y_1 y_2) + 1 - \sum_{j_1} d(j_1 i_2 | y_1 y_2) \\ &= 1 - d(i_1 i_2 | y_1 y_2) + 1 - \sum_{(j_1, j_2) \in S} d(j_1 j_2 | y_1 y_2) \\ &\geq 1 - d(i_1 i_2 | y_1 y_2), \end{aligned} \quad (10)$$

with $S := \{(i_1, j_2) : j_2 \in [k_2] - \{i_2\}\} \sqcup \{(j_1, i_2) : j_1 \in [k_1] - \{i_1\}\}$.

Thus, this implies that:

$$E_{\text{sum}}^{\text{NS}_{\text{dec}}}(W, k_1, k_2, e, d) \leq E^{\text{NS}_{\text{dec}}}(W, k_1, k_2, e, d) \leq 2E_{\text{sum}}^{\text{NS}_{\text{dec}}}(W, k_1, k_2, e, d),$$

and by maximizing over all e and d :

$$E_{\text{sum}}^{\text{NS}_{\text{dec}}}(W, k_1, k_2) \leq E^{\text{NS}_{\text{dec}}}(W, k_1, k_2) \leq 2E_{\text{sum}}^{\text{NS}_{\text{dec}}}(W, k_1, k_2).$$

As before, this implies that the capacity regions are the same. \square

We will now prove that sum success probabilities of the broadcast channel coding problem are the same with and without non-signaling assistance between decoders. In particular, this implies that non-signaling resources shared between decoders does not change the capacity region. Note that, after the publication of [28], Pereg et al. added a remark to the arXiv version of their paper that their result stating that entanglement shared between decoders does not change the capacity of a broadcast channel could be generalized to non-signaling assistance. The theorem below strengthens this result showing that non-signaling assistance between the decoders cannot increase the sum success probability even in the one-shot setting and for arbitrary broadcast channels.

Theorem 4.2. For any broadcast channel W and k_1, k_2 , we have $S_{\text{sum}}(W, k_1, k_2) = S_{\text{sum}}^{\text{NS}_{\text{dec}}}(W, k_1, k_2)$. As a consequence, $\mathcal{C}(W) = \mathcal{C}^{\text{NS}_{\text{dec}}}(W)$.

Proof. In the sum scenario, since the objective function does not depend on the product $d_1(j_1 | y_1) d_2(j_2 | y_2)$ but only on the marginals $d_1(j_1 | y_1)$ and $d_2(j_2 | y_2)$, the non-signaling box won't give additional decoding power. Indeed, for any encoder e and non-signaling decoding box d , we have that:

$$\begin{aligned} S_{\text{sum}}^{\text{NS}_{\text{dec}}}(W, k_1, k_2, e, d) &:= \frac{1}{2k_1 k_2} \sum_{i_1, x, y_1} W_1(y_1 | x) \left(\sum_{j_2} d(i_1 j_2 | y_1 y_2) \right) \sum_{i_2} e(x | i_1 i_2) \\ &+ \frac{1}{2k_1 k_2} \sum_{i_2, x, y_2} W_2(y_2 | x) \left(\sum_{j_1} d(j_1 i_2 | y_1 y_2) \right) \sum_{i_1} e(x | i_1 i_2). \end{aligned} \quad (11)$$

Thus, by choosing $d_1(j_1 | y_1) := \sum_{j_2} d(j_1 j_2 | y_1 y_2)$ and $d_2(j_2 | y_2) := \sum_{j_1} d(j_1 j_2 | y_1 y_2)$, which are well-defined since d is a non-signaling box, we have $S_{\text{sum}}(W, k_1, k_2, e, d_1, d_2) = S_{\text{sum}}^{\text{NS}_{\text{dec}}}(W, k_1, k_2, e, d)$. By

optimizing over all e and d , $S_{\text{sum}}^{\text{NS}_{\text{dec}}}(W, k_1, k_2) \leq S_{\text{sum}}(W, k_1, k_2)$. Since the inequality is obvious in the other direction, as $d(j_1 j_2 | y_1 y_2) := d_1(j_1 | y_1) d_2(j_2 | y_2)$ is always a non-signaling box, we have that $S_{\text{sum}}(W, k_1, k_2) = S_{\text{sum}}^{\text{NS}_{\text{dec}}}(W, k_1, k_2)$. This implies in particular that the capacity regions are the same, i.e. $\mathcal{C}_{\text{sum}}(W) = \mathcal{C}_{\text{sum}}^{\text{NS}_{\text{dec}}}(W)$.

Finally, since $\mathcal{C}(W) = \mathcal{C}_{\text{sum}}(W)$ by Proposition 3.2 and $\mathcal{C}_{\text{sum}}^{\text{NS}_{\text{dec}}}(W) = \mathcal{C}^{\text{NS}_{\text{dec}}}(W)$ by Proposition 4.1, we get that $\mathcal{C}(W) = \mathcal{C}^{\text{NS}_{\text{dec}}}(W)$. \square

4.2 Full Non-Signaling Assistance

In this section, we will consider the case where the sender and the receivers are given non-signaling assistance. This means that a three-party non-signaling box $P(x j_1 j_2 | (i_1 i_2) y_1 y_2)$ will replace the product $e(x | i_1 i_2) d_1(j_1 | y_1) d_2(j_2 | y_2)$ in the previous objective values. A joint conditional probability $P(x j_1 j_2 | (i_1 i_2) y_1 y_2)$ is a non-signaling box if the marginal from any two parties is independent of the remaining party's input:

$$\begin{aligned} \forall j_1, j_2, i_1, i_2, y_1, y_2, i'_1, i'_2, \quad & \sum_x P(x j_1 j_2 | (i_1 i_2) y_1 y_2) = \sum_x P(x j_1 j_2 | (i'_1 i'_2) y_1 y_2), \\ \forall x, j_2, i_1, i_2, y_1, y_2, y'_1, \quad & \sum_{j_1} P(x j_1 j_2 | (i_1 i_2) y_1 y_2) = \sum_{j_1} P(x j_1 j_2 | (i_1 i_2) y'_1 y_2), \\ \forall x, j_1, i_1, i_2, y_1, y_2, y'_2, \quad & \sum_{j_2} P(x j_1 j_2 | (i_1 i_2) y_1 y_2) = \sum_{j_2} P(x j_1 j_2 | (i_1 i_2) y_1 y'_2). \end{aligned} \quad (12)$$

The scenario is depicted in Figure 2.

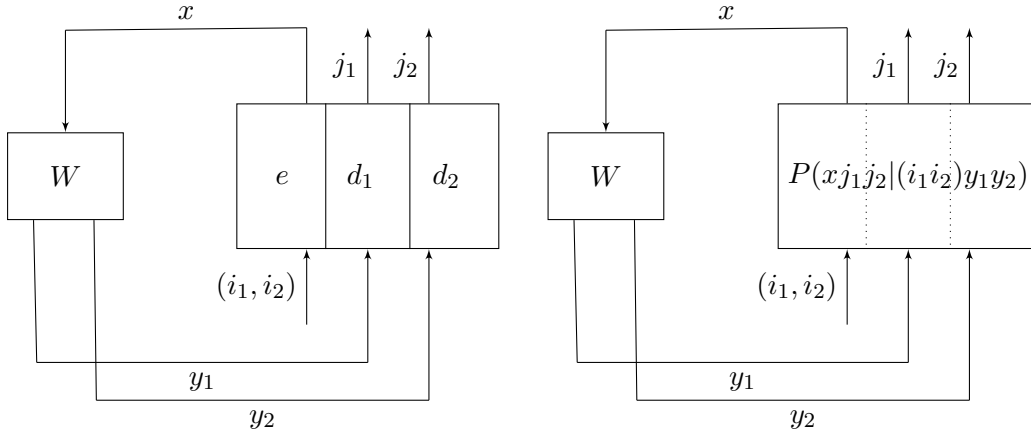

Figure 2: A non-signaling box P replacing e, d_1, d_2 in the coding problem for the broadcast channel W .

The cyclicity of Figure 2 is at first sight counter-intuitive. Note first that P being a non-signaling box is completely independent of W : in particular, the variables y_1, y_2 do not need to follow any laws in the definition of P being a non-signaling box. Therefore, the remaining ambiguity is the apparent need to encode and decode at the same time. However, since P is a non-signaling box, we won't need to do both at the same time, although the global correlation between the sender and the receivers will be characterized only by $P(x j_1 j_2 | (i_1 i_2) y_1 y_2)$; see [27] for a detailed discussion on that matter, the same paradox occurring for multiple-access channels and broadcast channels.

We will call the maximum sum success probability $S_{\text{sum}}^{\text{NS}}(W, k_1, k_2)$, which is given by the following

linear program, where the constraints translate precisely the fact that P is a non-signaling box:

$$\begin{aligned}
S_{\text{sum}}^{\text{NS}}(W, k_1, k_2) := & \underset{P}{\text{maximize}} \quad \frac{1}{2k_1k_2} \sum_{i_1, x, y_1} W_1(y_1|x) \sum_{i_2, j_2} P(xi_1j_2|(i_1i_2)y_1y_2) \\
& + \frac{1}{2k_1k_2} \sum_{i_2, x, y_2} W_2(y_2|x) \sum_{i_1, j_1} P(xj_1i_2|(i_1i_2)y_1y_2) \\
\text{subject to} & \sum_x P(xj_1j_2|(i_1i_2)y_1y_2) = \sum_x P(xj_1j_2|(i'_1i'_2)y_1y_2) \\
& \sum_{j_1} P(xj_1j_2|(i_1i_2)y_1y_2) = \sum_{j_1} P(xj_1j_2|(i_1i_2)y'_1y_2) \\
& \sum_{j_2} P(xj_1j_2|(i_1i_2)y_1y_2) = \sum_{j_2} P(xj_1j_2|(i_1i_2)y_1y'_2) \\
& \sum_{x, j_1, j_2} P(xj_1j_2|(i_1i_2)y_1y_2) = 1 \\
& P(xj_1j_2|(i_1i_2)y_1y_2) \geq 0
\end{aligned} \tag{13}$$

Since it is given as a linear program, the complexity of computing $S_{\text{sum}}^{\text{NS}}(W, k_1, k_2)$ is polynomial in the number of variables and constraints (see for instance Section 7.1 of [43]), which is a polynomial in $|\mathcal{X}|, |\mathcal{Y}_1|, |\mathcal{Y}_2|, k_1$ and k_2 .

Similarly, we define the maximum joint success probability $S^{\text{NS}}(W, k_1, k_2)$ in the following way:

$$\begin{aligned}
S^{\text{NS}}(W, k_1, k_2) := & \underset{P}{\text{maximize}} \quad \frac{1}{k_1k_2} \sum_{i_1, i_2, x, y_1, y_2} W(y_1y_2|x) P(xi_1i_2|(i_1i_2)y_1y_2) \\
\text{subject to} & \sum_x P(xj_1j_2|(i_1i_2)y_1y_2) = \sum_x P(xj_1j_2|(i'_1i'_2)y_1y_2) \\
& \sum_{j_1} P(xj_1j_2|(i_1i_2)y_1y_2) = \sum_{j_1} P(xj_1j_2|(i_1i_2)y'_1y_2) \\
& \sum_{j_2} P(xj_1j_2|(i_1i_2)y_1y_2) = \sum_{j_2} P(xj_1j_2|(i_1i_2)y_1y'_2) \\
& \sum_{x, j_1, j_2} P(xj_1j_2|(i_1i_2)y_1y_2) = 1 \\
& P(xj_1j_2|(i_1i_2)y_1y_2) \geq 0
\end{aligned} \tag{14}$$

We can rewrite both these programs in more convenient and smaller linear programs:

Proposition 4.3.

$$\begin{aligned}
S_{\text{sum}}^{\text{NS}}(W, k_1, k_2) = & \underset{p, r, r^1, r^2}{\text{maximize}} \quad \frac{1}{2k_1k_2} \left(\sum_{x, y_1} W_1(y_1|x) r_{x, y_1}^1 + \sum_{x, y_2} W_2(y_2|x) r_{x, y_2}^2 \right) \\
\text{subject to} & \sum_x r_{x, y_1, y_2} = 1 \\
& \sum_x r_{x, y_1}^1 = k_2 \\
& \sum_x r_{x, y_2}^2 = k_1 \\
& \sum_x p_x = k_1k_2 \\
& 0 \leq r_{x, y_1, y_2} \leq r_{x, y_1}^1, r_{x, y_2}^2 \leq p_x \\
& p_x - r_{x, y_1}^1 - r_{x, y_2}^2 + r_{x, y_1, y_2} \geq 0
\end{aligned} \tag{15}$$

$$\begin{aligned}
S^{\text{NS}}(W, k_1, k_2) = & \underset{p, r, r^1, r^2}{\text{maximize}} \quad \frac{1}{k_1 k_2} \sum_{x, y_1, y_2} W(y_1 y_2 | x) r_{x, y_1, y_2} \\
& \text{subject to} \quad \sum_x r_{x, y_1, y_2} = 1 \\
& \quad \sum_x r_{x, y_1}^1 = k_2 \\
& \quad \sum_x r_{x, y_2}^2 = k_1 \\
& \quad \sum_x p_x = k_1 k_2 \\
& \quad 0 \leq r_{x, y_1, y_2} \leq r_{x, y_1}^1, r_{x, y_2}^2 \leq p_x \\
& \quad p_x - r_{x, y_1}^1 - r_{x, y_2}^2 + r_{x, y_1, y_2} \geq 0
\end{aligned} \tag{16}$$

Proof. One can check that given a solution of the original program, the following choice of variables is a valid solution of the second program achieving the same objective value:

$$\begin{aligned}
r_{x, y_1, y_2} &:= \sum_{i_1, i_2} P(x i_1 i_2 | (i_1 i_2) y_1 y_2) , \\
r_{x, y_1}^1 &:= \sum_{j_2, i_1, i_2} P(x i_1 j_2 | (i_1 i_2) y_1 y_2) , \\
r_{x, y_2}^2 &:= \sum_{j_1, i_1, i_2} P(x j_1 i_2 | (i_1 i_2) y_1 y_2) , \\
p_x &:= \sum_{j_1, j_2, i_1, i_2} P(x j_1 j_2 | (i_1 i_2) y_1 y_2) .
\end{aligned} \tag{17}$$

For the other direction, given those variables, a non-signaling probability distribution $P(x j_1 j_2 | (i_1 i_2) y_1 y_2)$ is given by, for $j_1 \neq i_1$ and $j_2 \neq i_2$:

$$\begin{aligned}
P(x i_1 i_2 | (i_1 i_2) y_1 y_2) &= \frac{r_{x, y_1, y_2}}{k_1 k_2} , \\
P(x j_1 i_2 | (i_1 i_2) y_1 y_2) &= \frac{r_{x, y_2}^2 - r_{x, y_1, y_2}}{k_1 k_2 (k_1 - 1)} , \\
P(x i_1 j_2 | (i_1 i_2) y_1 y_2) &= \frac{r_{x, y_1}^1 - r_{x, y_1, y_2}}{k_1 k_2 (k_2 - 1)} , \\
P(x j_1 j_2 | (i_1 i_2) y_1 y_2) &= \frac{p_x - r_{x, y_1}^1 - r_{x, y_2}^2 + r_{x, y_1, y_2}}{k_1 k_2 (k_1 - 1) (k_2 - 1)} .
\end{aligned} \tag{18}$$

□

As before, we define the (resp. sum) capacity region with non-signaling assistance using Definition 2.1 by $\mathcal{C}^{\text{NS}}(W) := \mathcal{C}[\text{S}^{\text{NS}}](W)$ (resp. $\mathcal{C}_{\text{sum}}^{\text{NS}}(W) := \mathcal{C}[\text{S}_{\text{sum}}^{\text{NS}}](W)$).

Proposition 4.4. For any broadcast channel W , $\mathcal{C}^{\text{NS}}(W) = \mathcal{C}_{\text{sum}}^{\text{NS}}(W)$.

Proof. Let us show that:

$$2S_{\text{sum}}^{\text{NS}}(W, k_1, k_2) - 1 \leq S^{\text{NS}}(W, k_1, k_2) \leq S_{\text{sum}}^{\text{NS}}(W, k_1, k_2) .$$

This will imply in particular that:

$$\lim_{n \rightarrow +\infty} S^{\text{NS}}(W^{\otimes n}, \lceil 2^{R_1 n} \rceil, \lceil 2^{R_2 n} \rceil) = 1 \iff \lim_{n \rightarrow +\infty} S_{\text{sum}}^{\text{NS}}(W^{\otimes n}, \lceil 2^{R_1 n} \rceil, \lceil 2^{R_2 n} \rceil) = 1 ,$$

thus define the same capacity region.

Let us consider an optimal solution $p_x, r_{x,y_1,y_2}, r_{x,y_1}^1, r_{x,y_2}^2$ of the program computing $S_{\text{sum}}^{\text{NS}}(W, k_1, k_2)$. We have:

$$S_{\text{sum}}^{\text{NS}}(W, k_1, k_2) = \frac{1}{k_1 k_2} \left(\sum_{x,y_1,y_2} W(y_1 y_2 | x) \frac{r_{x,y_1}^1 + r_{x,y_2}^2}{2} \right).$$

However $r_{x,y_1}^1 + r_{x,y_2}^2 \leq p_x + r_{x,y_1,y_2}$ so we get that:

$$\begin{aligned} S_{\text{sum}}^{\text{NS}}(W, k_1, k_2) &\leq \frac{1}{2k_1 k_2} \left(\sum_{x,y_1,y_2} W(y_1 y_2 | x) (p_x + r_{x,y_1,y_2}) \right) \\ &= \frac{1}{2} + \frac{1}{2} \left[\frac{1}{k_1 k_2} \left(\sum_{x,y_1,y_2} W(y_1 y_2 | x) r_{x,y_1,y_2} \right) \right] \\ &\leq \frac{1}{2} + \frac{1}{2} S^{\text{NS}}(W, k_1, k_2), \end{aligned} \tag{19}$$

since $p_x, r_{x,y_1,y_2}, r_{x,y_1}^1, r_{x,y_2}^2$ is a valid solution of the program computing $S^{\text{NS}}(W, k_1, k_2)$.

On the other hand, consider now $p_x, r_{x,y_1,y_2}, r_{x,y_1}^1, r_{x,y_2}^2$ an optimal solution of the program computing $S^{\text{NS}}(W, k_1, k_2)$. We have that $r_{x,y_1,y_2} \leq r_{x,y_1}^1, r_{x,y_2}^2$ so we have that $r_{x,y_1,y_2} \leq \frac{r_{x,y_1}^1 + r_{x,y_2}^2}{2}$ and thus:

$$\begin{aligned} S^{\text{NS}}(W, k_1, k_2) &= \frac{1}{k_1 k_2} \left(\sum_{x,y_1,y_2} W(y_1 y_2 | x) r_{x,y_1,y_2} \right) \\ &\leq \frac{1}{k_1 k_2} \left(\sum_{x,y_1,y_2} W(y_1 y_2 | x) \frac{r_{x,y_1}^1 + r_{x,y_2}^2}{2} \right) \\ &\leq S_{\text{sum}}^{\text{NS}}(W, k_1, k_2), \end{aligned} \tag{20}$$

since $p_x, r_{x,y_1,y_2}, r_{x,y_1}^1, r_{x,y_2}^2$ is a valid solution of the program computing $S_{\text{sum}}^{\text{NS}}(W, k_1, k_2)$. This prove the inequalities $2S_{\text{sum}}^{\text{NS}}(W, k_1, k_2) - 1 \leq S^{\text{NS}}(W, k_1, k_2) \leq S_{\text{sum}}^{\text{NS}}(W, k_1, k_2)$, and thus concludes the proof. \square

5 Approximation Algorithm for Deterministic Broadcast Channel Coding

In this section, we will address the question of the approximability of $S(W, k_1, k_2)$, in the restricted scenario of a deterministic broadcast channel W . Specifically, we study the problem of finding a code $e : [k_1] \times [k_2] \rightarrow \mathcal{X}$, $d_1 : \mathcal{Y}_1 \rightarrow [k_1]$, $d_2 : \mathcal{Y}_2 \rightarrow [k_2]$ that maximizes the program computing $S(W, k_1, k_2)$. Note that the restriction to deterministic codes does not affect the value of the objective of the program which is convex, and that the problem is as hard as finding any code maximizing the program computing $S(W, k_1, k_2)$, as a deterministic code with a better or equal value can be retrieved easily from any code.

We say that W is deterministic if $\forall x, y_1, y_2, W(y_1 y_2 | x) \in \{0, 1\}$. We can then define $(W_1(x), W_2(x))$ as the only pair (y_1, y_2) such that $W(y_1 y_2 | x) = 1$, which exists uniquely as W is a conditional probability distribution. Thus, the deterministic broadcast channel coding problem can be defined in the following way:

Definition 5.1 (DETBC). Given a deterministic channel W and integers k_1 and k_2 , the deterministic broadcast channel coding problem, which we call DETBC, entails maximizing

$$S(W, k_1, k_2, e, d_1, d_2) := \frac{1}{k_1 k_2} \sum_{i_1, i_2} \mathbb{1}_{d_1(W_1(e(i_1 i_2)))=i_1} \mathbb{1}_{d_2(W_2(e(i_1 i_2)))=i_2}$$

over all functions $e : [k_1] \times [k_2] \rightarrow \mathcal{X}$, $d_1 : \mathcal{Y}_1 \rightarrow [k_1]$, $d_2 : \mathcal{Y}_2 \rightarrow [k_2]$.

5.1 Reformulation as a Bipartite Graph Problem

We will reformulate DETBCC as a bipartite graph problem. But first, let us introduce some notations:

Definition 5.2 (Graph notations). Consider a bipartite graph $G = (V_1 \sqcup V_2, E \subseteq V_1 \times V_2)$:

1. $G^{\mathcal{P}_1, \mathcal{P}_2}$, the quotient of G by partitions $\mathcal{P}_1, \mathcal{P}_2$ of respectively V_1, V_2 , is defined by:

$$G^{\mathcal{P}_1, \mathcal{P}_2} := (\mathcal{P}_1 \sqcup \mathcal{P}_2, \{(p_1, p_2) \in \mathcal{P}_1 \times \mathcal{P}_2 : E \cap (p_1 \times p_2) \neq \emptyset\}) .$$

2. $e_G(\mathcal{P}_1, \mathcal{P}_2) := |E^{G^{\mathcal{P}_1, \mathcal{P}_2}}|$ is the number of edges of $G^{\mathcal{P}_1, \mathcal{P}_2}$.
3. $N_G^{\mathcal{P}_1, \mathcal{P}_2}(p) := N_{G^{\mathcal{P}_1, \mathcal{P}_2}}(p)$ is the set of neighbors of $p \in \mathcal{P}_1 \sqcup \mathcal{P}_2$ in the graph $G^{\mathcal{P}_1, \mathcal{P}_2}$.
4. Similarly, $\deg_G^{\mathcal{P}_1, \mathcal{P}_2}(p) := \deg_{G^{\mathcal{P}_1, \mathcal{P}_2}}(p)$ is the degree, i.e. the number of neighbors, of p in the graph $G^{\mathcal{P}_1, \mathcal{P}_2}$.
5. We will use V_1, V_2 in previous notations when we do not partition on the left and right part respectively (or identify those to trivial partitions in singletons). For instance, $G^{V_1, V_2} = G$.
6. We will use the notations $e(\mathcal{P}_1, \mathcal{P}_2)$, $N_{\mathcal{P}_1, \mathcal{P}_2}(p)$ and $\deg_{\mathcal{P}_1, \mathcal{P}_2}(p)$ when the graph G considered is clear from context.

Now, let us remark that a deterministic channel W , up to a permutation of elements of \mathcal{X} , is characterized by the following bipartite graph:

Definition 5.3 (Bipartite Graph G_W associated with the deterministic channel W).

$$G_W := (\mathcal{Y}_1 \sqcup \mathcal{Y}_2, E = \{(y_1, y_2) \in \mathcal{Y}_1 \times \mathcal{Y}_2 : \exists x \in \mathcal{X}, y_1 = W_1(x) \text{ and } y_2 = W_2(x)\}) .$$

Indeed, permuting the elements of \mathcal{X} does not change G_W nor $S(W, k_1, k_2)$. As a consequence, up to a multiplicative factor $k_1 k_2$, we will show that DETBCC is equivalent to the following bipartite graph problem:

Definition 5.4 (DENSESTQUOTIENTGRAPH). Given a bipartite graph $G = (V_1 \sqcup V_2, E)$ and integers k_1, k_2 , the problem DENSESTQUOTIENTGRAPH entails maximizing $e_G(\mathcal{P}_1, \mathcal{P}_2)$, the number of edges of the quotient graph of G by $\mathcal{P}_1, \mathcal{P}_2$, over all partitions \mathcal{P}_1 of V_1 in k_1 parts and \mathcal{P}_2 of V_2 in k_2 parts.

Proposition 5.5. Given a deterministic channel W and integers k_1, k_2 , it is equivalent to solve DETBCC on W, k_1, k_2 or DENSESTQUOTIENTGRAPH on G_W, k_1, k_2 . That is to say, given an optimal solution of one of those problems, one can efficiently construct an optimal solution of the other. Furthermore, their optimal values satisfy $k_1 k_2 \text{DETBCC}(W, k_1, k_2) = \text{DENSESTQUOTIENTGRAPH}(G_W, k_1, k_2)$.

Proof. Consider an optimal solution e, d_1, d_2 of DETBCC. Note that d_1 defines a partition \mathcal{P}_1 of \mathcal{Y}_1 in k_1 parts and d_2 defines a partition \mathcal{P}_2 of \mathcal{Y}_2 in k_2 parts, with $\mathcal{P}_b^{i_b} := \{y_b \in \mathcal{Y}_b : d_b(y) = i_b\}$ for $b \in \{1, 2\}$. Then we have:

$$\begin{aligned} k_1 k_2 S(W, k_1, k_2, e, d_1, d_2) &= \sum_{i_1, i_2} \mathbb{1}_{i_1 = d_1(W_1(e(i_1, i_2)))} \mathbb{1}_{i_2 = d_2(W_2(e(i_1, i_2)))} \\ &= \sum_{i_1, i_2} \mathbb{1}_{W_1(e(i_1, i_2)) \in \mathcal{P}_1^{i_1}} \mathbb{1}_{W_2(e(i_1, i_2)) \in \mathcal{P}_2^{i_2}} . \end{aligned} \tag{21}$$

However, since we consider an optimal solution, we have that:

$$\mathbb{1}_{W_1(e(i_1, i_2)) \in \mathcal{P}_1^{i_1}} \mathbb{1}_{W_2(e(i_1, i_2)) \in \mathcal{P}_2^{i_2}} = \max_{x \in \mathcal{X}} \mathbb{1}_{W_1(x) \in \mathcal{P}_1^{i_1}} \mathbb{1}_{W_2(x) \in \mathcal{P}_2^{i_2}} ,$$

as $e(i_1, i_2)$ appears only here in the objective value. Thus:

$$\begin{aligned} k_1 k_2 S(W, k_1, k_2, e, d_1, d_2) &= \sum_{i_1, i_2} \max_{x \in \mathcal{X}} \mathbb{1}_{W_1(x) \in \mathcal{P}_1^{i_1}} \mathbb{1}_{W_2(x) \in \mathcal{P}_2^{i_2}} \\ &= \sum_{i_1, i_2} \mathbb{1}_{\exists (y_1, y_2) \in E^{G_W} : y_1 \in \mathcal{P}_1^{i_1} \text{ and } y_2 \in \mathcal{P}_2^{i_2}} \\ &= \sum_{i_1, i_2} \mathbb{1}_{E^{G_W} \cap (\mathcal{P}_1^{i_1} \times \mathcal{P}_2^{i_2}) \neq \emptyset} \\ &= e_{G_W}(\mathcal{P}_1, \mathcal{P}_2) , \end{aligned} \tag{22}$$

which proves that given an optimal solution of DETBCC, one can efficiently construct a solution $\mathcal{P}_1, \mathcal{P}_2$ of DENSESTQUOTIENTGRAPH such that:

$$e_{G_W}(\mathcal{P}_1, \mathcal{P}_2) = k_1 k_2 \text{DET BCC}(W, k_1, k_2) .$$

For the other direction, consider an optimal solution $\mathcal{P}_1, \mathcal{P}_2$ of DENSESTQUOTIENTGRAPH. We have as before that:

$$e_{G_W}(\mathcal{P}_1, \mathcal{P}_2) = \sum_{i_1, i_2} \max_{x \in \mathcal{X}} \mathbb{1}_{W_1(x) \in \mathcal{P}_1^{i_1}} \mathbb{1}_{W_2(x) \in \mathcal{P}_2^{i_2}} .$$

Now, let us define $e(i_1, i_2) \in \text{argmax}_{x \in \mathcal{X}} \mathbb{1}_{W_1(x) \in \mathcal{P}_1^{i_1}} \mathbb{1}_{W_2(x) \in \mathcal{P}_2^{i_2}}$ and $d_b(y_b)$ the index i_b such that $y_b \in \mathcal{P}_b^{i_b}$, for $b \in \{1, 2\}$. With those definitions, we get again that:

$$\begin{aligned} \max_{x \in \mathcal{X}} \mathbb{1}_{W_1(x) \in \mathcal{P}_1^{i_1}} \mathbb{1}_{W_2(x) \in \mathcal{P}_2^{i_2}} &= \mathbb{1}_{W_1(e(i_1, i_2)) \in \mathcal{P}_1^{i_1}} \mathbb{1}_{W_2(e(i_1, i_2)) \in \mathcal{P}_2^{i_2}} \\ &= \mathbb{1}_{i_1 = d_1(W_1(e(i_1, i_2)))} \mathbb{1}_{i_2 = d_2(W_2(e(i_1, i_2)))} , \end{aligned} \quad (23)$$

and thus we have:

$$\begin{aligned} e_{G_W}(\mathcal{P}_1, \mathcal{P}_2) &= \sum_{i_1, i_2} \max_{x \in \mathcal{X}} \mathbb{1}_{W_1(x) \in \mathcal{P}_1^{i_1}} \mathbb{1}_{W_2(x) \in \mathcal{P}_2^{i_2}} \\ &= \sum_{i_1, i_2} \mathbb{1}_{i_1 = d_1(W_1(e(i_1, i_2)))} \mathbb{1}_{i_2 = d_2(W_2(e(i_1, i_2)))} \\ &= k_1 k_2 \text{S}(W, k_1, k_2, e, d_1, d_2) , \end{aligned} \quad (24)$$

which proves that given an optimal solution of DENSESTQUOTIENTGRAPH, one can efficiently construct a solution e, d_1, d_2 of DETBCC such that:

$$k_1 k_2 \text{S}(W, k_1, k_2, e, d_1, d_2) = \text{DENSESTQUOTIENTGRAPH}(G_W, k_1, k_2) .$$

In particular, this implies that the optimal objective values satisfy:

$$k_1 k_2 \text{DET BCC}(W, k_1, k_2) = \text{DENSESTQUOTIENTGRAPH}(G_W, k_1, k_2) .$$

Therefore, the solutions of both problems constructed throughout the proof are in fact optimal. \square

Remark. Note that all bipartite graphs can be written as G_W for some deterministic broadcast channel W , with W unique up to a permutation of \mathcal{X} .

5.2 Approximation Algorithm for DENSESTQUOTIENTGRAPH

In this section, we will sort out how hard is DENSESTQUOTIENTGRAPH, and thanks to Proposition 5.5, how hard is it to solve DETBCC.

Theorem 5.6. There exists a polynomial-time $(1 - e^{-1})^2$ -approximation algorithm for DENSESTQUOTIENTGRAPH. Furthermore, it is NP-hard to solve exactly DENSESTQUOTIENTGRAPH.

Corollary 5.7. There exists a polynomial-time $(1 - e^{-1})^2$ -approximation algorithm for DETBCC. Furthermore, it is NP-hard to solve exactly DETBCC.

The approximation algorithm is a two-step process. First, we consider the problem of maximizing $\sum_{i_2=1}^{k_2} \min(k_1, \text{deg}_{V_1, \mathcal{P}_2}(\mathcal{P}_2^{i_2}))$ over all partitions \mathcal{P}_2 of V_2 in k_2 parts. We will show that this is a special case of the submodular welfare problem, which can be approximated within a factor $1 - e^{-1}$ in polynomial time [44]. We then choose the partition \mathcal{P}_1 on V_1 in k_1 parts uniformly at random. This partition pair will give an objective value $e(\mathcal{P}_1, \mathcal{P}_2)$ within a $(1 - e^{-1})^2$ factor from the optimal solution in expectation.

Proof of Theorem 5.6. Consider first the hardness result. Let us show that the decision version of DENSESTQUOTIENTGRAPH is NP-complete. It is in NP, the certificate being the two partitions and the selection of edges between those partitions. It is NP-hard as one of its particular cases is the SETSPLITTING problem (see for instance [45]), in the case where $k_1 = 2$ and $k_2 = |V_2|$, by interpreting the neighbors of $v_2 \in V_2$ as a set covering elements of V_1 .

We will show nonetheless that this problem can be approximated within a factor $(1 - e^{-1})^2$ in polynomial time. First we consider the case where $k_2 = |V_2|$. We can then always assume that the right partition is $\mathcal{P}_2 := \{\{v_2\} : v_2 \in V_2\}$, which leads necessarily to a greater or equal number of edges in the quotient graph that with any other right partition. So, in that setting, we only need to find a partition of V_1 in k_1 parts maximizing the number of edges between vertices in the right part and the quotient of the left vertices.

First, the maximum value we can get is upper bounded by $\sum_{v_2 \in V_2} \min(k_1, \deg(v_2))$. Indeed, each vertex of v_2 can be connected at most to the k_1 parts of V_1 , so its contribution is bounded by k_1 , and there needs to be an edge to each part it is connected, so its contribution is also bounded by $\deg(v_2)$. Let us show that if we take a partition \mathcal{P}_1 of V_1 uniformly at random, we get:

$$\begin{aligned} \mathbb{E}_{\mathcal{P}_1}[e(\mathcal{P}_1, V_2)] &\geq \left(1 - \left(1 - \frac{1}{k_1}\right)^{k_1}\right) \sum_{v_2 \in V_2} \min(k_1, \deg(v_2)) \\ &\geq (1 - e^{-1}) \max_{\mathcal{P}_1} e(\mathcal{P}_1, V_2). \end{aligned} \quad (25)$$

We have $e(\mathcal{P}_1, V_2) = \sum_{v_2 \in V_2} \deg_{\mathcal{P}_1, V_2}(v_2)$, so by linearity of expectation $\mathbb{E}_{\mathcal{P}_1}[e(\mathcal{P}_1, V_2)] = \sum_{v_2 \in V_2} \mathbb{E}_{\mathcal{P}_1}[\deg_{\mathcal{P}_1, V_2}(v_2)]$. However $\deg_{\mathcal{P}_1, V_2}(v_2) = |\{i_1 \in [k_1] : N(v_2) \cap \mathcal{P}_1^{i_1} \neq \emptyset\}|$. Recall also that for any v_1 , $\mathbb{P}(v_1 \in \mathcal{P}_1^{i_1}) = \frac{1}{k_1}$ since the partition is taken uniformly at random. Thus, we get:

$$\begin{aligned} \mathbb{E}_{\mathcal{P}_1}[\deg_{\mathcal{P}_1, V_2}(v_2)] &= \mathbb{E}_{\mathcal{P}_1}[|\{i_1 \in [k_1] : N(v_2) \cap \mathcal{P}_1^{i_1} \neq \emptyset\}|] = \mathbb{E}_{\mathcal{P}_1}\left[\sum_{i_1=1}^{k_1} \mathbb{1}_{N(v_2) \cap \mathcal{P}_1^{i_1} \neq \emptyset}\right] \\ &= \sum_{i_1=1}^{k_1} \mathbb{E}_{\mathcal{P}_1}\left[\mathbb{1}_{N(v_2) \cap \mathcal{P}_1^{i_1} \neq \emptyset}\right] = \sum_{i_1=1}^{k_1} \mathbb{P}(N(v_2) \cap \mathcal{P}_1^{i_1} \neq \emptyset) \\ &= \sum_{i_1=1}^{k_1} (1 - \mathbb{P}(N(v_2) \cap \mathcal{P}_1^{i_1} = \emptyset)) \\ &= \sum_{i_1=1}^{k_1} \left(1 - \prod_{v_1 \in N(v_2)} \mathbb{P}(v_1 \notin \mathcal{P}_1^{i_1})\right) \\ &= \sum_{i_1=1}^{k_1} \left(1 - \prod_{v_1 \in N(v_2)} \mathbb{P}(v_1 \notin \mathcal{P}_1^{i_1})\right) = k_1 \left(1 - \left(1 - \frac{1}{k_1}\right)^{\deg(v_2)}\right), \end{aligned} \quad (26)$$

since $\mathbb{P}(v_1 \notin \mathcal{P}_1^{i_1}) = 1 - \frac{1}{k_1}$ and $|N(v_2)| = \deg(v_2)$. So, in all:

$$\mathbb{E}_{\mathcal{P}_1}[e(\mathcal{P}_1, V_2)] = \sum_{v_2 \in V_2} \mathbb{E}_{\mathcal{P}_1}[\deg_{\mathcal{P}_1, V_2}(v_2)] = k_1 \sum_{v_2 \in V_2} \left(1 - \left(1 - \frac{1}{k_1}\right)^{\deg(v_2)}\right).$$

However, the function $f : x \mapsto 1 - \left(1 - \frac{1}{k_1}\right)^x$ is nondecreasing concave with $f(0) = 0$, so $\frac{f(x)}{x} \geq \frac{f(y)}{y}$ for $x \leq y$. In particular, we have that:

$$f(\min(k_1, \deg(v_2))) \geq \frac{\min(k_1, \deg(v_2))}{k_1} f(k_1),$$

and thus:

$$\begin{aligned}
\mathbb{E}_{\mathcal{P}_1}[e(\mathcal{P}_1, V_2)] &\geq k_1 \sum_{v_2 \in V_2} \left(1 - \left(1 - \frac{1}{k_1} \right)^{\min(k_1, \deg(v_2))} \right) \\
&\geq k_1 \frac{\sum_{v_2 \in V_2} \min(k_1, \deg(v_2))}{k_1} \left(1 - \left(1 - \frac{1}{k_1} \right)^{k_1} \right) \\
&\geq \left(1 - \left(1 - \frac{1}{k_1} \right)^{k_1} \right) \sum_{v_2 \in V_2} \min(k_1, \deg(v_2)) \\
&\geq (1 - e^{-1}) \max_{\mathcal{P}_1} e(\mathcal{P}_1, V_2) .
\end{aligned} \tag{27}$$

Let us now consider the general case with k_2 unconstrained. We apply the previous discussion on the graph G^{V_1, \mathcal{P}_2} for some fixed partition \mathcal{P}_2 of V_2 . Since $e_{G^{V_1, \mathcal{P}_2}}(\mathcal{P}_1, \mathcal{P}_2) = e(\mathcal{P}_1, \mathcal{P}_2)$, we have the upper bound:

$$\max_{\mathcal{P}_1} e(\mathcal{P}_1, \mathcal{P}_2) \leq \sum_{i_2=1}^{k_2} \min(k_1, \deg_{V_1, \mathcal{P}_2}(\mathcal{P}_2^{i_2})) ,$$

and the previous algorithm gives us a partition \mathcal{P}_1 of V_1 such that:

$$e(\mathcal{P}_1, \mathcal{P}_2) \geq (1 - e^{-1}) \sum_{i_2=1}^{k_2} \min(k_1, \deg_{V_1, \mathcal{P}_2}(\mathcal{P}_2^{i_2})) .$$

Therefore, let us focus on the following optimization problem:

$$\max_{\mathcal{P}_2} \sum_{i_2=1}^{k_2} \min(k_1, \deg_{V_1, \mathcal{P}_2}(\mathcal{P}_2^{i_2})) ,$$

We will give a $(1 - e^{-1})$ -approximation algorithm running in polynomial time for this problem. In all, this will allow us to get in polynomial time a partition pair $(\mathcal{P}_1, \mathcal{P}_2)$ such that:

$$\begin{aligned}
e(\mathcal{P}_1, \mathcal{P}_2) &\geq (1 - e^{-1}) \sum_{i_2=1}^{k_2} \min(k_1, \deg_{V_1, \mathcal{P}_2}(\mathcal{P}_2^{i_2})) \\
&\geq (1 - e^{-1})^2 \max_{\mathcal{P}_2} \sum_{i_2=1}^{k_2} \min(k_1, \deg_{V_1, \mathcal{P}_2}(\mathcal{P}_2^{i_2})) \\
&\geq (1 - e^{-1})^2 \max_{\mathcal{P}_1, \mathcal{P}_2} e(\mathcal{P}_1, \mathcal{P}_2) .
\end{aligned} \tag{28}$$

The problem $\max_{\mathcal{P}_2} \sum_{i_2=1}^{k_2} \min(k_1, \deg_{V_1, \mathcal{P}_2}(\mathcal{P}_2^{i_2}))$ is a particular instance of the submodular welfare problem from [44]. Note that $\deg_{V_1, \mathcal{P}_2}(\mathcal{P}_2^{i_2}) = \deg_{V_1, \{\mathcal{P}_2^{i_2}, V_2 - \mathcal{P}_2^{i_2}\}}(\mathcal{P}_2^{i_2})$, as the degree of $\mathcal{P}_2^{i_2}$ does not depend on the rest of the partition \mathcal{P}_2 . Then, $h(S_2) := \min(k_1, \deg_{V_1, \{S_2, V_2 - S_2\}}(S_2))$, for $S_2 \subseteq V_2$, is a nondecreasing submodular function, as $S_2 \mapsto \deg_{V_1, \{S_2, V_2 - S_2\}}(S_2)$ is a nondecreasing submodular function on V_2 and $\min(k_1, \cdot)$ is nondecreasing concave. Thus, we want to maximize $\sum_{i_2=1}^{k_2} h(S_{i_2})$ where $(S_{i_2})_{i_2 \in [k_2]}$ is a partition of items in V_2 among k_2 bidders. It is a particular case of the submodular welfare problem where each nondecreasing submodular utility weight is the same for all bidders and equal to h . Thus, thanks to [44], there exists a polynomial-time $(1 - e^{-1})$ -approximation of $\max_{\mathcal{P}_2} \sum_{i_2=1}^{k_2} \min(k_1, \deg_{V_1, \mathcal{P}_2}(\mathcal{P}_2^{i_2}))$. \square

5.3 Non-Signaling Assisted Capacity Region for Deterministic Channels

Thanks to Theorem 5.6 and Proposition 5.5, there exists a constant-factor approximation algorithm for the broadcast channel coding problem running in polynomial time. We aim to show here that the

non-signaling assisted value is linked by a constant factor to the unassisted one. Indeed, the hope is that the non-signaling assisted program is linked to the linear relaxation of the unassisted problem, thus is likely a good approximation since the broadcast channel coding problem can be approximated in polynomial time.

This turns out to be true, and will be proved through the following theorem:

Theorem 5.8. If W is a deterministic broadcast channel, then for all $\ell_1 \leq k_1$ and $\ell_2 \leq k_2$:

$$\left(1 - \frac{k_1^{k_1} e^{-k_1}}{k_1!}\right) \left(1 - \left(1 - \frac{1}{\ell_1}\right)^{k_1}\right) \left(1 - \left(1 - \frac{1}{\ell_2}\right)^{k_2}\right) S^{\text{NS}}(W, k_1, k_2) \leq S(W, \ell_1, \ell_2).$$

Corollary 5.9. For any deterministic broadcast channel W , $\mathcal{C}^{\text{NS}}(W) = \mathcal{C}(W)$.

Proof. We apply Theorem 5.8 on the deterministic broadcast channel $W^{\otimes n}$.

We fix $k_1 = 2^{nR_1}$, $k_2 = 2^{nR_2}$ and $\ell_1 = \frac{2^{nR_1}}{n}$, $\ell_2 = \frac{2^{nR_2}}{n}$. Since $1 - \left(1 - \frac{1}{\ell}\right)^k \geq 1 - e^{-\frac{k}{\ell}}$, we get:

$$\left(1 - \frac{k_1^{k_1} e^{-k_1}}{k_1!}\right) (1 - e^{-n})^2 S^{\text{NS}}(W^{\otimes n}, 2^{nR_1}, 2^{nR_1}) \leq S\left(W^{\otimes n}, \frac{2^{nR_1}}{n}, \frac{2^{nR_2}}{n}\right).$$

As $\left(1 - \frac{k_1^{k_1} e^{-k_1}}{k_1!}\right) (1 - e^{-n})^2$ tends to 1 when n tends to infinity, we get $\forall \varepsilon > 0$, $\exists N \in \mathbb{N}$, $\forall n \geq N$:

$$(1 - \varepsilon) S^{\text{NS}}(W^{\otimes n}, 2^{nR_1}, 2^{nR_1}) \leq S(W^{\otimes n}, 2^{n(R_1 - \frac{\log(n)}{n})}, 2^{n(R_2 - \frac{\log(n)}{n})}).$$

Thus, if $\lim_{n \rightarrow +\infty} S^{\text{NS}}(W^{\otimes n}, 2^{nR_1}, 2^{nR_1}) = 1$, we have that for all $R'_1 < R_1$ and $R'_2 < R_2$:

$$\lim_{n \rightarrow +\infty} S(W^{\otimes n}, 2^{nR'_1}, 2^{nR'_1}) \geq 1 - \varepsilon.$$

Since this is true for all $\varepsilon > 0$, we get in fact that $\lim_{n \rightarrow +\infty} S(W^{\otimes n}, 2^{nR'_1}, 2^{nR'_1}) = 1$. This implies that $\mathcal{C}^{\text{NS}}(W) \subseteq \mathcal{C}(W)$, and thus that the capacity regions are equal as the other inclusion is always satisfied. \square

Let us now prove the main result:

Proof of Theorem 5.8. The proof will be done in three parts. We will work on the graph G_W (see Definition 5.3).

1. First, we prove that for any partition \mathcal{P}_2 of \mathcal{Y}_2 in ℓ_2 parts:

$$S(W, \ell_1, \ell_2) \geq \left(1 - \left(1 - \frac{1}{\ell_1}\right)^{k_1}\right) \frac{\sum_{i_2=1}^{\ell_2} \min(k_1, \deg_{\mathcal{Y}_1, \mathcal{P}_2}(\mathcal{P}_2^{i_2}))}{k_1 \ell_2}.$$

2. Then, we show that there exists a partition \mathcal{P}_2 such that:

$$\begin{aligned} & \frac{\sum_{i_2=1}^{\ell_2} \min(k_1, \deg_{\mathcal{Y}_1, \mathcal{P}_2}(\mathcal{P}_2^{i_2}))}{k_1 \ell_2} \\ & \geq \left(1 - \frac{k_1^{k_1} e^{-k_1}}{k_1!}\right) \left(1 - \left(1 - \frac{1}{\ell_2}\right)^{k_2}\right) \frac{\min(k_1 k_2, \sum_{y_1} \min(k_2, \deg(y_1)))}{k_1 k_2}. \end{aligned} \quad (29)$$

3. Finally, we prove that:

$$\frac{\min(k_1 k_2, \sum_{y_1} \min(k_2, \deg(y_1)))}{k_1 k_2} \geq S^{\text{NS}}(W, k_1, k_2).$$

By combining these three inequalities, we get precisely the claimed result.

1. This part shares a lot of similarities with the proof of Theorem 5.6, which we will adapt to this particular situation. Let us show that if we take a partition \mathcal{P}_1 of \mathcal{Y}_1 of size ℓ_1 uniformly at random, we get, for some fixed \mathcal{P}_2 of size ℓ_2 :

$$\mathbb{E}_{\mathcal{P}_1}[e_{G_W}(\mathcal{P}_1, \mathcal{P}_2)] \geq \frac{\ell_1}{k_1} \left(1 - \left(1 - \frac{1}{\ell_1}\right)^{k_1}\right) \sum_{i_2=1}^{\ell_2} \min(k_1, \deg_{\mathcal{Y}_1, \mathcal{P}_2}(\mathcal{P}_2^{i_2})) .$$

Since $\ell_1 \ell_2 S(W, \ell_1, \ell_2) = \max_{\mathcal{P}_1 \text{ in } \ell_1 \text{ parts}, \mathcal{P}_2 \text{ in } \ell_2 \text{ parts}} e_{G_W}(\mathcal{P}_1, \mathcal{P}_2)$ by Proposition 5.5, this will imply that:

$$\begin{aligned} S(W, \ell_1, \ell_2) &\geq \frac{1}{\ell_1 \ell_2} \mathbb{E}_{\mathcal{P}_1}[e_{G_W}(\mathcal{P}_1, \mathcal{P}_2)] \\ &\geq \left(1 - \left(1 - \frac{1}{\ell_1}\right)^{k_1}\right) \frac{\sum_{i_2=1}^{\ell_2} \min(k_1, \deg_{\mathcal{Y}_1, \mathcal{P}_2}(\mathcal{P}_2^{i_2}))}{k_1 \ell_2} . \end{aligned} \quad (30)$$

We have that $e_{G_W}(\mathcal{P}_1, \mathcal{P}_2) = \sum_{i_2=1}^{\ell_2} \deg_{\mathcal{P}_1, \mathcal{P}_2}(\mathcal{P}_2^{i_2})$, so by linearity of expectation, we have that $\mathbb{E}_{\mathcal{P}_1}[e_{G_W}(\mathcal{P}_1, \mathcal{P}_2)] = \sum_{i_2=1}^{\ell_2} \mathbb{E}_{\mathcal{P}_1}[\deg_{\mathcal{P}_1, \mathcal{P}_2}(\mathcal{P}_2^{i_2})]$, so we will focus on the contribution of one particular $\mathcal{P}_2^{i_2}$.

Then, we have that $\deg_{\mathcal{P}_1, \mathcal{P}_2}(\mathcal{P}_2^{i_2}) = |\{i_1 \in [\ell_1] : N_{\mathcal{Y}_1, \mathcal{P}_2}(\mathcal{P}_2^{i_2}) \cap \mathcal{P}_1^{i_1} \neq \emptyset\}|$. Recall that $\mathbb{P}(v_1 \in \mathcal{P}_1^{i_1}) = \frac{1}{\ell_1}$ for any v_1 since the partition is taken uniformly at random. Thus:

$$\begin{aligned} \mathbb{E}_{\mathcal{P}_1}[\deg_{\mathcal{P}_1, \mathcal{P}_2}(\mathcal{P}_2^{i_2})] &= \mathbb{E}_{\mathcal{P}_1} [|\{i_1 \in [\ell_1] : N_{\mathcal{Y}_1, \mathcal{P}_2}(\mathcal{P}_2^{i_2}) \cap \mathcal{P}_1^{i_1} \neq \emptyset\}|] \\ &= \mathbb{E}_{\mathcal{P}_1} \left[\sum_{i_1=1}^{\ell_1} \mathbb{1}_{N_{\mathcal{Y}_1, \mathcal{P}_2}(\mathcal{P}_2^{i_2}) \cap \mathcal{P}_1^{i_1} \neq \emptyset} \right] = \sum_{i_1=1}^{\ell_1} \mathbb{E}_{\mathcal{P}_1} \left[\mathbb{1}_{N_{\mathcal{Y}_1, \mathcal{P}_2}(\mathcal{P}_2^{i_2}) \cap \mathcal{P}_1^{i_1} \neq \emptyset} \right] \\ &= \sum_{i_1=1}^{\ell_1} \mathbb{P}(N_{\mathcal{Y}_1, \mathcal{P}_2}(\mathcal{P}_2^{i_2}) \cap \mathcal{P}_1^{i_1} \neq \emptyset) = \sum_{i_1=1}^{\ell_1} (1 - \mathbb{P}(N_{\mathcal{Y}_1, \mathcal{P}_2}(\mathcal{P}_2^{i_2}) \cap \mathcal{P}_1^{i_1} = \emptyset)) \\ &= \sum_{i_1=1}^{\ell_1} \left(1 - \prod_{v_1 \in N(\mathcal{P}_2^{i_2})} \mathbb{P}(v_1 \notin \mathcal{P}_1^{i_1})\right) = \ell_1 \left(1 - \left(1 - \frac{1}{\ell_1}\right)^{\deg_{\mathcal{Y}_1, \mathcal{P}_2}(\mathcal{P}_2^{i_2})}\right) . \end{aligned} \quad (31)$$

So, in all we have that:

$$\begin{aligned} \mathbb{E}_{\mathcal{P}_1}[e_{G_W}(\mathcal{P}_1, \mathcal{P}_2)] &= \sum_{i_2=1}^{\ell_2} \mathbb{E}_{\mathcal{P}_1}[\deg_{\mathcal{P}_1, \mathcal{P}_2}(\mathcal{P}_2^{i_2})] \\ &= \ell_1 \sum_{i_2=1}^{\ell_2} \left(1 - \left(1 - \frac{1}{\ell_1}\right)^{\deg_{\mathcal{Y}_1, \mathcal{P}_2}(\mathcal{P}_2^{i_2})}\right) . \end{aligned} \quad (32)$$

However the function $f : x \mapsto 1 - \left(1 - \frac{1}{\ell_1}\right)^x$ is nondecreasing concave with $f(0) = 0$, so $\frac{f(x)}{x} \geq \frac{f(y)}{y}$ for $x \leq y$. In particular, we have that:

$$f(\min(k_1, \deg_{\mathcal{Y}_1, \mathcal{P}_2}(\mathcal{P}_2^{i_2}))) \geq \frac{\min(k_1, \deg_{\mathcal{Y}_1, \mathcal{P}_2}(\mathcal{P}_2^{i_2}))}{k_1} f(k_1) ,$$

and thus:

$$\begin{aligned}
\mathbb{E}_{\mathcal{P}_1}[e_{G_W}(\mathcal{P}_1, \mathcal{P}_2)] &\geq \ell_1 \sum_{i_2=1}^{\ell_2} \left(1 - \left(1 - \frac{1}{\ell_1} \right)^{\min(k_1, \deg_{\mathcal{Y}_1, \mathcal{P}_2}(\mathcal{P}_2^{i_2}))} \right) \\
&\geq \ell_1 \frac{\sum_{i_2=1}^{\ell_2} \min(k_1, \deg_{\mathcal{Y}_1, \mathcal{P}_2}(\mathcal{P}_2^{i_2}))}{k_1} \left(1 - \left(1 - \frac{1}{\ell_1} \right)^{k_1} \right) \\
&= \frac{\ell_1}{k_1} \left(1 - \left(1 - \frac{1}{\ell_1} \right)^{k_1} \right) \sum_{i_2=1}^{\ell_2} \min(k_1, \deg_{\mathcal{Y}_1, \mathcal{P}_2}(\mathcal{P}_2^{i_2})) ,
\end{aligned} \tag{33}$$

which concludes the first part of the proof.

2. Let us take \mathcal{P}_2 a partition of \mathcal{Y}_2 of size ℓ_2 uniformly at random, and let us prove that:

$$\mathbb{E} \left[\sum_{i_2=1}^{\ell_2} \min(k_1, \deg_{\mathcal{Y}_1, \mathcal{P}_2}(\mathcal{P}_2^{i_2})) \right]$$

is greater than or equal to:

$$\frac{\ell_2}{k_2} \left(1 - \frac{k_1^{k_1} e^{-k_1}}{k_1!} \right) \left(1 - \left(1 - \frac{1}{\ell_2} \right)^{k_2} \right) \min \left(k_1 k_2, \sum_{y_1} \min(k_2, \deg(y_1)) \right) .$$

First, $\sum_{i_2=1}^{\ell_2} \min(k_1, \deg_{\mathcal{Y}_1, \mathcal{P}_2}(\mathcal{P}_2^{i_2})) = \sum_{i_2=1}^{\ell_2} \varphi(\deg_{\mathcal{Y}_1, \mathcal{P}_2}(\mathcal{P}_2^{i_2}))$ with $\varphi(j) := \min(k_1, j)$ which is a concave function. The Poisson concavity ratio, introduced in [30], is defined by $\alpha_\varphi = \inf_{x \in \mathbb{R}^+} \frac{\mathbb{E}[\varphi(\text{Poi}(x))]}{\varphi(x)}$ and is equal to $1 - \frac{k_1^{k_1} e^{-k_1}}{k_1!}$ for that particular function [30]. We will use the following property from [30]:

Proposition 5.10 (Lemma 2.2 from [30]). For φ concave, and $p \in [0, 1]^m$, we have:

$$\mathbb{E} \left[\varphi \left(\sum_{i=1}^m \text{Ber}(p_i) \right) \right] \geq \mathbb{E} \left[\varphi \left(\text{Poi} \left(\sum_{i=1}^m p_i \right) \right) \right] .$$

Let us find the law of $\deg_{\mathcal{Y}_1, \mathcal{P}_2}(\mathcal{P}_2^{i_2})$:

$$\begin{aligned}
\deg_{\mathcal{Y}_1, \mathcal{P}_2}(\mathcal{P}_2^{i_2}) &= \sum_{y_1} \mathbb{1}_{N(y_1) \cap \mathcal{P}_2^{i_2} \neq \emptyset} = \sum_{y_1} \left(1 - \mathbb{1}_{N(y_1) \cap \mathcal{P}_2^{i_2} = \emptyset} \right) \\
&= \sum_{y_1} \left(1 - \mathbb{1}_{\forall y_2 \in N(y_1), y_2 \notin \mathcal{P}_2^{i_2}} \right) = \sum_{y_1} \text{Ber} \left(1 - \left(1 - \frac{1}{\ell_2} \right)^{\deg(y_1)} \right)
\end{aligned} \tag{34}$$

Thus:

$$\begin{aligned}
\mathbb{E} [\varphi(\deg_{\mathcal{Y}_1, \mathcal{P}_2}(\mathcal{P}_2^{i_2}))] &= \mathbb{E} \left[\varphi \left(\sum_{y_1} \text{Ber} \left(1 - \left(1 - \frac{1}{\ell_2} \right)^{\deg(y_1)} \right) \right) \right] \\
&\geq \mathbb{E} \left[\varphi \left(\text{Poi} \left(\sum_{y_1} \left(1 - \left(1 - \frac{1}{\ell_2} \right)^{\deg(y_1)} \right) \right) \right) \right] \text{ by Proposition 5.10} \\
&\geq \alpha_\varphi \varphi \left(\sum_{y_1} \left(1 - \left(1 - \frac{1}{\ell_2} \right)^{\deg(y_1)} \right) \right) \text{ by definition of } \alpha_\varphi .
\end{aligned} \tag{35}$$

But:

$$\begin{aligned}
\sum_{y_1} \left(1 - \left(1 - \frac{1}{\ell_2} \right)^{\deg(y_1)} \right) &\geq \sum_{y_1} \left(1 - \left(1 - \frac{1}{\ell_2} \right)^{\min(k_2, \deg(y_1))} \right) \\
&\geq \left(1 - \left(1 - \frac{1}{\ell_2} \right)^{k_2} \right) \frac{1}{k_2} \sum_{y_1} \min(k_2, \deg(y_1)) ,
\end{aligned} \tag{36}$$

as before. Since φ is concave and $\varphi(0) = 0$, we have in particular that for all $0 \leq c \leq 1$ and $x \in \mathbb{R}$, $\varphi(cx) \geq c\varphi(x)$. We know also that φ is nondecreasing. This implies that:

$$\begin{aligned} & \varphi \left(\sum_{y_1} \left(1 - \left(1 - \frac{1}{\ell_2} \right)^{\deg(y_1)} \right) \right) \\ & \geq \varphi \left(\left(1 - \left(1 - \frac{1}{\ell_2} \right)^{k_2} \right) \frac{1}{k_2} \sum_{y_1} \min(k_2, \deg(y_1)) \right) \\ & \geq \left(1 - \left(1 - \frac{1}{\ell_2} \right)^{k_2} \right) \varphi \left(\frac{1}{k_2} \sum_{y_1} \min(k_2, \deg(y_1)) \right), \end{aligned} \quad (37)$$

as $0 \leq 1 - \left(1 - \frac{1}{\ell_2} \right)^{k_2} \leq 1$. Thus $\mathbb{E} [\varphi(\deg_{\mathcal{Y}_1, \mathcal{P}_2}(\mathcal{P}_2^{i_2}))]$ is larger than or equal to:

$$\begin{aligned} & \alpha_\varphi \left(1 - \left(1 - \frac{1}{\ell_2} \right)^{k_2} \right) \min \left(k_1, \frac{1}{k_2} \sum_{y_1} \min(k_2, \deg(y_1)) \right) \\ & = \frac{1}{k_2} \left(1 - \frac{k_1^{k_1} e^{-k_1}}{k_1!} \right) \left(1 - \left(1 - \frac{1}{\ell_2} \right)^{k_2} \right) \min \left(k_1 k_2, \sum_{y_1} \min(k_2, \deg(y_1)) \right) \end{aligned} \quad (38)$$

since $\alpha_\varphi = 1 - \frac{k_1^{k_1} e^{-k_1}}{k_1!}$.

Finally, $\mathbb{E} \left[\sum_{i_2=1}^{\ell_2} \min(k_1, \deg_{\mathcal{Y}_1, \mathcal{P}_2}(\mathcal{P}_2^{i_2})) \right] = \sum_{i_2=1}^{\ell_2} \mathbb{E} [\varphi(\deg_{\mathcal{Y}_1, \mathcal{P}_2}(\mathcal{P}_2^{i_2}))]$, so we get that:

$$\mathbb{E} \left[\sum_{i_2=1}^{\ell_2} \min(k_1, \deg_{\mathcal{Y}_1, \mathcal{P}_2}(\mathcal{P}_2^{i_2})) \right]$$

is larger than or equal to:

$$\frac{\ell_2}{k_2} \left(1 - \frac{k_1^{k_1} e^{-k_1}}{k_1!} \right) \left(1 - \left(1 - \frac{1}{\ell_2} \right)^{k_2} \right) \min \left(k_1 k_2, \sum_{y_1} \min(k_2, \deg(y_1)) \right).$$

Thus, in particular, there exists some partition \mathcal{P}_2 that satisfies the same inequality, which concludes the second part of the proof.

3. Let us consider an optimal solution $r_{x, y_1, y_2}, p_x, r_{x, y_1}^1, r_{x, y_2}^2$ of the program computing $S^{\text{NS}}(W, k_1, k_2)$, so that $S^{\text{NS}}(W, k_1, k_2) = \frac{1}{k_1 k_2} \sum_x r_{x, W_1(x), W_2(x)}$.

(a) It comes directly from $r_{x, y_1, y_2} \leq p_x$ that:

$$\sum_x r_{x, W_1(x), W_2(x)} \leq \sum_x p_x = k_1 k_2.$$

(b) $\sum_x r_{x, W_1(x), W_2(x)} = \sum_{y_1} \sum_{x: W_1(x)=y_1} r_{x, y_1, W_2(x)}$ and we have that:

- i. $\sum_{x: W_1(x)=y_1} r_{x, y_1, W_2(x)} \leq \sum_{x: W_1(x)=y_1} 1 = \deg(y_1)$,
- ii. $\sum_{x: W_1(x)=y_1} r_{x, y_1, W_2(x)} \leq \sum_{x: W_1(x)=y_1} r_{x, y_1}^1 \leq \sum_x r_{x, y_1}^1 = k_2$,

so $\sum_{x: W_1(x)=y_1} r_{x, y_1, W_2(x)} \leq \min(k_2, \deg(y_1))$, and thus:

$$\sum_x r_{x, W_1(x), W_2(x)} \leq \sum_{y_1} \min(k_2, \deg(y_1)).$$

In all, we get that:

$$S^{\text{NS}}(W, k_1, k_2) = \frac{1}{k_1 k_2} \sum_x r_{x, W_1(x), W_2(x)} \leq \frac{\min(k_1 k_2, \sum_{y_1} \min(k_2, \deg(y_1)))}{k_1 k_2},$$

which concludes the third and last part of the proof. \square

6 Hardness of Approximation for Broadcast Channel Coding

Since broadcast channels are more general than point-to-point channels (by defining $W_1(y_1|x) := \hat{W}(y_1|x)$ for \hat{W} a point-to-point channel and taking $W_2(y_2|x) = \frac{1}{|\mathcal{Y}_2|}$ a completely trivial channel), computing a single value $S(W, k_1, k_2)$ is NP-hard, and it is even NP-hard to approximate within a better factor than $1 - e^{-1}$, as a consequence of the hardness result for point-to-point channels from [1].

The goal of this section is to give some evidence for the hardness of approximation of the general broadcast channel coding problem, specifically that it cannot be approximated in polynomial time within a $\Omega(1)$ factor. This suggests that non-signaling assistance might enlarge the capacity region of the channel as discussed in the introduction.

Formally, one would want to show that it is NP-hard to approximate this problem within a $\Omega(1)$ factor in polynomial time. We were however unable to prove this. Instead, we will prove a $\Omega\left(\frac{1}{\sqrt{m}}\right)$ -approximation hardness in the value query model.

First, let us introduce formally the problem:

Definition 6.1 (BCC). Given a channel W and integers k_1, k_2 , the broadcast channel coding problem, which we call BCC, entails maximizing:

$$S(W, k_1, k_2, e, d_1, d_2) := \frac{1}{k_1 k_2} \sum_{i_1, i_2, y_1, y_2} W(y_1 y_2 | e(i_1, i_2)) \mathbb{1}_{d_1(y_1)=i_1, d_2(y_2)=i_2} ,$$

over all functions $e : [k_1] \times [k_2] \rightarrow \mathcal{X}$, $d_1 : \mathcal{Y}_1 \rightarrow [k_1]$ and $d_2 : \mathcal{Y}_2 \rightarrow [k_2]$.

As in the deterministic case, we restrict ourselves to deterministic encoders and decoders, which does not change the value nor the hardness of the problem. Also, it can be equivalently stated in terms of partitions corresponding to d_1, d_2 as:

Proposition 6.2 (Equivalent formulation of BCC). Given a channel W and integers k_1 and k_2 , the broadcast channel coding problem, which we call BCC, entails maximizing:

$$\frac{1}{k_1 k_2} \sum_{i_1, i_2} \max_x \sum_{y_1 \in \mathcal{P}_1^{i_1}, y_2 \in \mathcal{P}_2^{i_2}} W(y_1 y_2 | x) ,$$

over all partitions \mathcal{P}_1 of \mathcal{Y}_1 in k_1 parts and \mathcal{P}_2 of \mathcal{Y}_2 in k_2 parts.

6.1 Social Welfare Reformulation

The social welfare maximization problem is defined as follows: given a set M of m items as well as k bidders with their associated utilities $(v_i : 2^M \rightarrow \mathbb{R}_+)_{i \in [k]}$, the goal is to partition M between the bidders to maximize the sum of their utilities. Formally, we want to compute:

$$\underset{\mathcal{P} \text{ partition in } k \text{ parts of } M}{\text{maximize}} \sum_{i=1}^k v_i(\mathcal{P}^i) .$$

Let us show that the subproblem of BCC restricted to $k_2 = |\mathcal{Y}_2|$ can be reformulated as a particular instance of the social welfare maximization problem. In that case, it is easy to see that $\mathcal{P}_2 = (\{y_2\})_{y_2 \in \mathcal{Y}_2}$ is always an optimal solution. Indeed, for any partition \mathcal{P}_2 , we have:

$$\begin{aligned} \frac{1}{k_1 |\mathcal{Y}_2|} \sum_{i_1, i_2} \max_x \sum_{y_1 \in \mathcal{P}_1^{i_1}, y_2 \in \mathcal{P}_2^{i_2}} W(y_1 y_2 | x) &\leq \frac{1}{k_1 |\mathcal{Y}_2|} \sum_{i_1, i_2} \sum_{y_2 \in \mathcal{P}_2^{i_2}} \max_x \sum_{y_1 \in \mathcal{P}_1^{i_1}} W(y_1 y_2 | x) \\ &= \frac{1}{k_1 |\mathcal{Y}_2|} \sum_{i_1} \sum_{y_2 \in \mathcal{Y}_2} \max_x \sum_{y_1 \in \mathcal{P}_1^{i_1}} W(y_1 y_2 | x) . \end{aligned} \tag{39}$$

Therefore, the objective function becomes:

$$S^1(W, k_1, \mathcal{P}_1) := \frac{1}{k_1} \sum_{i_1=1}^{k_1} f_W^1(\mathcal{P}_1^{i_1}) \text{ with } f_W^1(S_1) := \frac{1}{|\mathcal{Y}_2|} \sum_{y_2} \max_x \sum_{y_1 \in S_1} W(y_1 y_2 | x) .$$

Hence, up to a multiplicative factor k_1 , maximizing $S^1(W, k_1, \mathcal{P}_1)$ over all partitions \mathcal{P}_1 of size k_1 is a particular case of the social welfare maximization problem with a common utility f_W^1 for all k_1 bidders.

6.2 Value Query Hardness

Let us first introduce the value query model. As described in [37, 38], a value query to a utility v asks for the value of some input set $S \subseteq M$, and gets as response $v(S) \in \mathbb{R}_+$. In the value query model, we aim at solving the social welfare maximization problem accessing the data only through value queries to $(v_i)_{i \in [k]}$.

This is more restricted than using any algorithm, but in such a model, it is possible to show unconditional lower bounds on the number of queries needed to solve a given problem within an approximation rate. In the case of the social welfare maximization problem with XOS utility functions, the approximation rate achievable in polynomial time has been proved in [37, 38] to be of the order of $\Theta\left(\frac{1}{\sqrt{m}}\right)$. Specifically, in [37], a $\Omega\left(\frac{1}{m^{\frac{1}{2}}}\right)$ -approximation in polynomial time was given, and in [38], it has been shown that any $\Omega\left(\frac{1}{m^{\frac{1}{2}-\varepsilon}}\right)$ -approximation for $\varepsilon > 0$ requires an exponential number of value queries. We will adapt their proof in the particular case of one common XOS utility function of the form f_W^1 for some broadcast channel W . But first, let us introduce the definition of XOS functions and prove that f_W^1 is one of those.

Definition 6.3. A linear valuation function (also known as additive) is a set function $a : 2^M \rightarrow \mathbb{R}_+$ that assigns a nonnegative value to every singleton $\{j\}$ for $j \in M$, and for all $S \subseteq M$ it holds that $a(S) = \sum_{j \in S} a(\{j\})$.

A fractionally sub-additive function (XOS) is a set function $f : 2^M \rightarrow \mathbb{R}_+$, for which there is a finite set of linear valuation functions $A = \{a_1, \dots, a_\ell\}$ such that $f(S) = \max_{i \in [\ell]} a_i(S)$ for every $S \subseteq M$.

Remark. Note that the size of A is not bounded in the definition.

Proposition 6.4. f_W^1 is XOS.

Proof.

$$\begin{aligned} f_W^1(S) &= \frac{1}{|\mathcal{Y}_2|} \sum_{y_2} \max_x \sum_{y_1 \in S_1} W(y_1 y_2 | x) = \max_{\lambda: \mathcal{Y}_2 \rightarrow \mathcal{X}} a_\lambda(S), \text{ where} \\ a_\lambda(S) &= \frac{1}{|\mathcal{Y}_2|} \sum_{y_2} \sum_{y_1 \in S} W(y_1 y_2 | \lambda(y_2)) = \sum_{y_1 \in S} \left[\frac{1}{|\mathcal{Y}_2|} \sum_{y_2} W(y_1 y_2 | m(y_2)) \right] \\ &= \sum_{y_1 \in S} a_\lambda(\{y_1\}) \text{ with } a_\lambda(\{y_1\}) = \frac{1}{|\mathcal{Y}_2|} \sum_{y_2} W(y_1 y_2 | \lambda(y_2)) \in \mathbb{R}_+ \end{aligned} \quad (40)$$

So f_W^1 is the maximum of the set of a_λ for $\lambda \in \mathcal{X}^{\mathcal{Y}_2}$, which are linear valuation functions, thus f_W^1 is XOS. \square

Let us now state the value query hardness of approximation of the broadcast channel problem:

Theorem 6.5. In the value query model, for any fixed $\varepsilon > 0$, a $\Omega\left(\frac{1}{m^{\frac{1}{2}-\varepsilon}}\right)$ -approximation algorithm for the broadcast channel coding problem on W, k_1, k_2 , restricted to the case of $|\mathcal{Y}_2| = k_2$ and $m = |\mathcal{Y}_1| = k_1^2$, requires exponentially many value queries to f_W^1 .

Remark. As our problem is a particular instance of the social welfare maximization problem with XOS functions, the polynomial-time $\Omega\left(\frac{1}{m^{\frac{1}{2}}}\right)$ -approximation from [37] works also here.

Proof. The proof is inspired by Theorem 3.1 of [38]. We will show using probabilistic arguments that any $\Omega\left(\frac{1}{m^{\frac{1}{2}-\varepsilon}}\right)$ -approximation algorithm requires an exponential number of value queries. Let us fix a small constant $\delta > 0$. We choose $k_1 \in \mathbb{N}$ as the number of messages (the bidders) and the output space

$\mathcal{Y}_1 := [m]$ with $m := k_1^2$ (the items). Then, we choose uniformly at random an equi-partition of \mathcal{Y}_1 in k_1 parts of size k_1 , which we name T_1, \dots, T_{k_1} .

Let us define now $\mathcal{Y}_2 := [m + k_1 + 1]$. We take $\mathcal{X} := \mathcal{Y}_2 = [m + 1 + k_1]$ as well. We can now define our broadcast channel W , with some positive constant C to be fixed later to guarantee that W is a conditional probability distribution. Let us define its value for $y_2 = 1$:

$$W(y_1 1|x) := C \times \begin{cases} m^{2\delta} \mathbb{1}_{y_1=x} & \text{when } 1 \leq x \leq m, \\ \frac{1}{m^{\frac{1}{2}-\delta}} & \text{when } x = m + 1, \\ \mathbb{1}_{y_1 \in T_j} & \text{when } 1 \leq j := x - (m + 1) \leq k_1. \end{cases}$$

Then, we define other y_2 inputs as translations of $W(y_1 1|x)$. Specifically, we define:

$$W(y_1 y_2|x) := W(y_1 1|t_{y_2-1}(x)) \text{ with } t_s(x) := 1 + [(x - 1 + s) \bmod (m + k_1 + 1)].$$

All coefficients are nonnegative. So W will be a channel if for all x , $\sum_{y_1, y_2} W(y_1 y_2|x) = 1$. However, one has, for some fixed x_0 :

$$\begin{aligned} \sum_{y_1, y_2} W(y_1 y_2|x_0) &= \sum_{y_1} \sum_{y_2} W(y_1 y_2|x_0) = \sum_{y_1} \sum_{y_2} W(y_1 1|t_{y_2-1}(x_0)) = \sum_{y_1} \sum_x W(y_1 1|x) \\ &= C \sum_{y_1} \left[\sum_{1 \leq i \leq m} m^{2\delta} \mathbb{1}_{y_1=i} + \frac{1}{m^{\frac{1}{2}-\delta}} + \sum_{1 \leq j \leq k_1} \mathbb{1}_{y_1 \in T_j} \right] \\ &= C \left[\sum_{1 \leq i \leq m} m^{2\delta} + m \times \frac{1}{m^{\frac{1}{2}-\delta}} + \sum_{1 \leq j \leq k_1} k_1 \right] \\ &= 1, \end{aligned} \tag{41}$$

by choosing $C = \frac{1}{m^{1+2\delta} + m^{\frac{1}{2}+\delta} + m}$, which does not depend on x_0 . Thus, we have defined a correct instance of our problem. Note that on this instance, we have:

$$\begin{aligned} f_W^1(S) &= \frac{1}{|\mathcal{Y}_2|} \sum_{y_2} \max_x \sum_{y_1 \in S} W(y_1 y_2|x) = \sum_{y_2} \max_x \sum_{y_1 \in S} W(y_1 1|t_{y_2-1}(x)) \\ &= \frac{m + k_1 + 1}{|\mathcal{Y}_2|} \max_x \sum_{y_1 \in S} W(y_1 1|x) \text{ since } t_{y_2-1} \text{ bijection} \\ &= \frac{C(m + k_1 + 1)}{|\mathcal{Y}_2|} \times \max \begin{cases} m^{2\delta} |\{i\} \cap S| & \text{for } 1 \leq i \leq m \\ \frac{1}{m^{\frac{1}{2}-\delta}} |S| & \\ |T_j \cap S| & \text{for } 1 \leq j \leq k_1 \end{cases} \end{aligned} \tag{42}$$

Let us also consider an alternate broadcast channel W' , with the only difference that $\mathbb{1}_{y_1 \in T_j}$ is replaced by $\frac{1}{m^{\frac{1}{2}}}$, for $j \in [k_1]$. For that channel, the constant C remains the same (since $\sum_j \sum_{y_1} \mathbb{1}_{y_1 \in T_j} = k_1 \times k_1 = k_1 \times m \times \frac{1}{k_1} = \sum_j \sum_{y_1} \frac{1}{m^{\frac{1}{2}}}$), so we get that:

$$\begin{aligned} f_{W'}^1(S) &= \frac{C(m + k_1 + 1)}{|\mathcal{Y}_2|} \times \max \begin{cases} m^{2\delta} |\{i\} \cap S| & \text{for } 1 \leq i \leq m \\ \frac{1}{m^{\frac{1}{2}-\delta}} |S| & \\ \frac{1}{m^{\frac{1}{2}}} |S| & \text{for } 1 \leq j \leq k_1 \end{cases} \\ &= \frac{C(m + k_1 + 1)}{|\mathcal{Y}_2|} \times \max \begin{cases} m^{2\delta} |\{i\} \cap S| & \text{for } 1 \leq i \leq m \\ \frac{1}{m^{\frac{1}{2}-\delta}} |S| & \end{cases} \end{aligned} \tag{43}$$

since $\frac{1}{m^{\frac{1}{2}}} |S| \leq \frac{1}{m^{\frac{1}{2}-\delta}} |S|$. Let us consider normalized versions $v(S) := \frac{|\mathcal{Y}_2|}{C(m+k_1+1)} f_W^1(S)$ and $v'(S) := \frac{|\mathcal{Y}_2|}{C(m+k_1+1)} f_{W'}^1(S)$, so distinguishing between v and v' is the same as distinguishing between f_W^1 and

$f_{W'}^1$. We will prove that it takes an exponential number of value queries to distinguish between v and v' . On the one hand, one can easily show that the maximum value of the social welfare problem with v' is $(k_1 - 1)m^{2\delta} + \frac{1}{m^{\frac{1}{2}-\delta}}(m - (k_1 - 1)) = O(m^{\frac{1}{2}+2\delta})$, obtained taking $(k_1 - 1)$ singletons as the first components of the partition (the bidders), giving the rest of \mathcal{Y}_1 (the items) to the last. On the other hand, the maximum value of the social welfare problem with v is $k_1 \times k_1 = m$, obtained with the partition T_1, \dots, T_{k_1} . The fact that it requires an exponential number of value queries to distinguish between the two situations will imply that one cannot get an approximation rate better than $\Omega\left(\frac{1}{m^{\frac{1}{2}-2\delta}}\right)$ in less than an exponential number of value queries.

We will now prove that distinguishing between v and v' requires an exponential number of value queries. Note first that $v(\emptyset) = v'(\emptyset) = 0$, so we do not need to consider empty sets.

Let us fix some non-empty set $S \subseteq [m]$. Let us define the random boolean variables $X_j^i := \mathbb{1}_{i \in T_j}$ for $j \in [k_1]$ and $i \in [m]$. By construction of the random equi-partition T_1, \dots, T_{k_1} , $(X_j^i)_{i \in [m]}$ is a permutation distribution (see Definition 2.8) of $(0, \dots, 0, 1, \dots, 1)$ with $m - k_1$ zeros and k_1 ones, each X_j^i following a Bernoulli law of parameter $p := \frac{1}{k_1}$. Thus it is negatively associated by Proposition 2.9, and the sub-family $(X_j^i)_{i \in S}$ is negatively associated as well by Proposition 2.4. Note in particular that $|T_j \cap S| = \sum_{i \in S} X_j^i$ is a sum of negatively associated Bernoulli variables of the same parameter p , so the version of the Chernoff-Hoeffding bound from Proposition 2.10 holds.

Let us first assume that S is of size $0 < |S| \leq m^{\frac{1}{2}+\delta}$. Then, we have that $\frac{1}{m^{\frac{1}{2}-\delta}}|S| \leq m^{2\delta}$, so we get that $v'(S) = m^{2\delta}$. On the other hand, we have that:

$$v(S) = \max \begin{cases} m^{2\delta} \\ |T_j \cap S| \text{ for } 1 \leq j \leq k_1 \end{cases} \quad (44)$$

Thus, $v(S)$ is different from $v'(S)$ if and only if $\exists j \in [k_1], |T_j \cap S| > m^{2\delta}$. But, we have:

$$\begin{aligned} \mathbb{P}(\exists j \in [k_1], |T_j \cap S| > m^{2\delta}) &\leq \sum_{j \in [k_1]} \mathbb{P}(|T_j \cap S| > m^{2\delta}) \text{ by union bound} \\ &= \sum_{j \in [k_1]} \mathbb{P}\left(\sum_{i \in S} X_j^i > m^{2\delta}\right) = \sum_{j \in [k_1]} \mathbb{P}\left(\frac{1}{|S|} \sum_{i \in S} X_j^i > \left(1 + \frac{m^{2\delta} - 1}{|S|}\right) p\right) \\ &\leq \sum_{j \in [k_1]} \mathbb{P}\left(\frac{1}{|S|} \sum_{i \in S} X_j^i > \left(1 + \frac{m^{2\delta}}{|S|}\right) p\right) \\ &\leq \sum_{j \in [k_1]} \exp\left(-\frac{p|S|}{4} \left(\frac{m^{2\delta}}{p|S|}\right)^2\right) \text{ by Proposition 2.10} \\ &= \sum_{j \in [k_1]} \exp\left(-\frac{1}{4p|S|} m^{4\delta}\right) \leq \sum_{j \in [k_1]} \exp\left(-\frac{m^{-\delta}}{4} m^{4\delta}\right) \text{ since } \frac{1}{p|S|} = \frac{k_1}{|S|} \geq m^{-\delta} \\ &= m^{\frac{1}{2}} e^{-\frac{m^{3\delta}}{4}}. \end{aligned} \quad (45)$$

Thus, this event occurs with exponentially small probability (on the choice of the partition T_1, \dots, T_{k_1}).

Let us now study the case of S of size $|S| > m^{\frac{1}{2}+\delta}$. Then, we have that $\frac{1}{m^{\frac{1}{2}-\delta}}|S| > m^{2\delta}$, so we get that $v'(S) = \frac{1}{m^{\frac{1}{2}-\delta}}|S|$. On the other hand, we have that:

$$v(S) = \max \begin{cases} \frac{1}{m^{\frac{1}{2}-\delta}}|S| \\ |T_j \cap S| \text{ for } 1 \leq j \leq k_1 \end{cases} \quad (46)$$

Thus, $v(S)$ is different from $v'(S)$ if and only if $\exists j \in [k_1], |T_j \cap S| > \frac{1}{m^{\frac{1}{2}-\delta}} |S|$. But, we have:

$$\begin{aligned}
& \mathbb{P} \left(\exists j \in [k_1], |T_j \cap S| > \frac{1}{m^{\frac{1}{2}-\delta}} |S| \right) \leq \sum_{j \in [k_1]} \mathbb{P} \left(|T_j \cap S| > \frac{1}{m^{\frac{1}{2}-\delta}} |S| \right) \text{ by union bound} \\
& = \sum_{j \in [k_1]} \mathbb{P} \left(\sum_{i \in S} X_j^i > \frac{1}{m^{\frac{1}{2}-\delta}} |S| \right) = \sum_{j \in [k_1]} \mathbb{P} \left(\frac{1}{|S|} \sum_{i \in S} X_j^i > \left(1 + \frac{1}{|S| m^{\frac{1}{2}-\delta}} |S| - 1 \right) p \right) \\
& \leq \sum_{j \in [k_1]} \mathbb{P} \left(\frac{1}{|S|} \sum_{i \in S} X_j^i > \left(1 + \frac{1}{m^{\frac{1}{2}-\delta}} \right) p \right) \\
& = \sum_{j \in [k_1]} \mathbb{P} \left(\frac{1}{|S|} \sum_{i \in S} X_j^i > (1 + m^\delta) p \right) \text{ since } p = \frac{1}{k_1} = \frac{1}{m^{\frac{1}{2}}} \\
& \leq \sum_{j \in [k_1]} \exp \left(-\frac{p|S|}{4} m^{2\delta} \right) \text{ by Proposition 2.10} \\
& \leq \sum_{j \in [k_1]} \exp \left(-\frac{m^\delta}{4} m^{2\delta} \right) \text{ since } p|S| = \frac{|S|}{k_1} \geq m^\delta \\
& = m^{\frac{1}{2}} e^{-\frac{m^{3\delta}}{4}} .
\end{aligned} \tag{47}$$

Thus, this event occurs with exponentially small probability as well. We have then that for all set S , $\mathbb{P}(v(S) \neq v'(S)) \leq p_{\text{leak}} := m^{\frac{1}{2}} e^{-\frac{m^{3\delta}}{4}}$, which is an exponentially small bound that does not depend on S .

Hence, for every set S , only with exponentially small probability p_{leak} can one distinguish between v and v' . For some fixed algorithm \mathcal{A} , let us consider the sequence L of queries made by \mathcal{A} before it is able to distinguish between v and v' : $L := (S_1, \dots, S_n)$, with $v(S_i) = v'(S_i)$ for $i \in [n]$ and $v'(S_{n+1}) > v(S_{n+1})$. L is independent of T_1, \dots, T_{k_1} as no information from this partition is leaked before S_{n+1} . Thus, for such an algorithm to be correct, it should work for any equi-partition T_1, \dots, T_{k_1} . We have:

$$\mathbb{P}(\exists i \in [n] : v(S_i) \neq v'(S_i)) \leq \sum_{i=1}^n \mathbb{P}(v(S_i) \neq v'(S_i)) = np_{\text{leak}} \text{ by union bound.}$$

In particular, this implies that:

$$\mathbb{P}(\forall i \in [n] : v(S_i) = v'(S_i)) \geq 1 - np_{\text{leak}} .$$

So, if $1 - np_{\text{leak}} > 0$, i.e. $n < \frac{1}{p_{\text{leak}}}$, then there exists some equi-partition T_1, \dots, T_{k_1} such that our algorithm outputs a sequence L of queries of length n before being able to distinguish between v and v' . In particular, we can take $n = \frac{1}{2p_{\text{leak}}}$ so that L is of exponential size. Hence, for any algorithm \mathcal{A} , there exists some equi-partition T_1, \dots, T_{k_1} such that \mathcal{A} needs an exponential number of value queries to distinguish between v and v' . This concludes the proof of the theorem for any deterministic algorithm.

Finally, the hardness result holds also for randomized algorithms. Indeed, let us call \mathcal{A}_s , the running algorithm conditioned on its random bits being s . \mathcal{A}_s is deterministic so the previous proof holds: with high probability p , the sequence of $\lfloor \frac{1-p}{p_{\text{leak}}} \rfloor$ queries does not reveal anything to distinguish between v and v' , although it is of exponential size in m . Then, averaging over all its random bitstrings, the same result holds, as p_{leak} is independent of the equi-partition T_1, \dots, T_{k_1} . \square

6.3 Limitations of the Model

The main weakness of the previous result is that it highly relies on the restriction that one has access to the data only through value queries. Indeed, if one has access to the full data, it is possible to read the partition T_1, \dots, T_{k_1} which gives the optimal solution directly. This weakness comes from the fact that

our utility function f_W^1 can be described by polynomial-size data, as it is characterized by a broadcast channel W , whereas if we write it in the XOS form as a maximum of linear valuation functions, it will in general have an exponential-size defining set of linear valuation functions.

7 Conclusion

We have studied several algorithmic aspects and non-signaling assisted capacity regions of broadcast channels. We have shown that sum success probabilities of the broadcast channel coding problem are the same with and without non-signaling assistance between decoders, and that it implied that non-signaling resource shared between decoders does not change the capacity region. For the class of deterministic broadcast channels, we have described a $(1 - e^{-1})^2$ -approximation algorithm running in polynomial time, and we have shown that the capacity region for that class is the same with or without non-signaling assistance. Finally, we have shown that in the value query model, we cannot achieve a better approximation ratio than $\Omega\left(\frac{1}{\sqrt{m}}\right)$ in polynomial time for the general broadcast channel coding problem, with m the size of one of the outputs of the channel.

Our results suggest that non-signaling assistance could improve the capacity region of general broadcast channels, which is left as a major open question. An intermediate result would be to show that it is NP-hard to approximate the broadcast channel coding problem within any constant ratio, strengthening our hardness result without relying on the value query model. Finally, one could also try to develop approximations algorithms for other sub-classes of broadcast channels, such as semi-deterministic or degraded ones. This could be a crucial step towards showing that the capacity region for those classes is the same with or without non-signaling assistance.

Acknowledgements

We would like to thank Stéphan Thomassé and Siddharth Barman for discussions on graph algorithms and social welfare problems respectively. We would also like to thank Mario Berta and Andreas Winter for discussions on broadcast channel. This work is funded by the European Research Council (ERC Grant AlgoQIP, Agreement No. 851716). It has also received funding from the European Union's Horizon 2020 research and innovation programme within the QuantERA II Programme under Grant Agreement No 101017733.

References

- [1] Siddharth Barman and Omar Fawzi. Algorithmic aspects of optimal channel coding. *IEEE Trans. Inf. Theory*, 64(2):1038–1045, 2018. doi:10.1109/TIT.2017.2696963.
- [2] Thomas M. Cover. Broadcast channels. *IEEE Trans. Inf. Theory*, 18(1):2–14, 1972. doi:10.1109/TIT.1972.1054727.
- [3] Claude E. Shannon. A mathematical theory of communication. *Bell Syst. Tech. J.*, 27(3):379–423, 1948. doi:10.1002/j.1538-7305.1948.tb01338.x.
- [4] Henry Heng-Jiunn Liao. Multiple access channels (Ph.D. Thesis abstr.). *IEEE Trans. Inf. Theory*, 19(2):253, 1973. doi:10.1109/TIT.1973.1054960.
- [5] Rudolf Ahlswede. Multi-way communication channels. In *2nd International Symposium on Information Theory, Tsahkadsor, Armenia, USSR, September 2-8, 1971*, pages 23–52. Publishing House of the Hungarian Academy of Science, 1973.
- [6] Patrick P. Bergmans. Random coding theorem for broadcast channels with degraded components. *IEEE Trans. Inf. Theory*, 19(2):197–207, 1973. doi:10.1109/TIT.1973.1054980.
- [7] R.G. Gallager. Capacity and coding for degraded broadcast channels. *Problemy Peredachi Informatsii*, 10(3):3–14, 1974.

- [8] Rudolf Ahlswede and János Körner. Source coding with side information and a converse for degraded broadcast channels. *IEEE Trans. Inf. Theory*, 21(6):629–637, 1975. doi:10.1109/TIT.1975.1055469.
- [9] Katalin Marton. The capacity region of deterministic broadcast channels. In *Trans. Int. Symp. Inform. Theory*, pages 243–248, 1977.
- [10] Mark Semenovitch Pinsker. Capacity of noiseless broadcast channel. *Problemy Peredachi Informatsii*, 14(2):28–34, 1978.
- [11] Sergei Izrail’evich Gel’fand and Mark Semenovitch Pinsker. Capacity of a broadcast channel with one deterministic component. *Problemy Peredachi Informatsii*, 16(1):24–34, 1980.
- [12] Thomas M. Cover. An achievable rate region for the broadcast channel. *IEEE Transactions on Information Theory*, 21(4):399–404, 1975. doi:10.1109/TIT.1975.1055418.
- [13] Edward C. van der Meulen. Random coding theorems for the general discrete memoryless broadcast channel. *IEEE Trans. Inf. Theory*, 21(2):180–190, 1975. doi:10.1109/TIT.1975.1055347.
- [14] Katalin Marton. A coding theorem for the discrete memoryless broadcast channel. *IEEE Trans. Inf. Theory*, 25(3):306–311, 1979. doi:10.1109/TIT.1979.1056046.
- [15] Hiroshi Sato. An outer bound to the capacity region of broadcast channels (corresp.). *IEEE Trans. Inf. Theory*, 24(3):374–377, 1978. doi:10.1109/TIT.1978.1055883.
- [16] Chandra Nair and Abbas El Gamal. An outer bound to the capacity region of the broadcast channel. *IEEE Trans. Inf. Theory*, 53(1):350–355, 2007. doi:10.1109/TIT.2006.887492.
- [17] Amin Gohari and Chandra Nair. New outer bounds for the two-receiver broadcast channel. In *IEEE International Symposium on Information Theory, ISIT 2020, Los Angeles, CA, USA, June 21-26, 2020*, pages 1492–1497. IEEE, 2020. doi:10.1109/ISIT44484.2020.9174003.
- [18] Nicolas Brunner, Daniel Cavalcanti, Stefano Pironio, Valerio Scarani, and Stephanie Wehner. Bell nonlocality. *Rev. Mod. Phys.*, 86:419–478, Apr 2014. doi:10.1103/RevModPhys.86.419.
- [19] R. Prevedel, Y. Lu, W. Matthews, R. Kaltenbaek, and K. J. Resch. Entanglement-enhanced classical communication over a noisy classical channel. *Phys. Rev. Lett.*, 106:110505, Mar 2011. doi:10.1103/PhysRevLett.106.110505.
- [20] Charles H. Bennett, Gilles Brassard, Claude Crépeau, Richard Jozsa, Asher Peres, and William K. Wootters. Teleporting an unknown quantum state via dual classical and einstein-podolsky-rosen channels. *Phys. Rev. Lett.*, 70:1895–1899, Mar 1993. doi:10.1103/PhysRevLett.70.1895.
- [21] Charles H Bennett, Peter W Shor, John A Smolin, and Ashish V Thapliyal. Entanglement-assisted classical capacity of noisy quantum channels. *Physical Review Letters*, 83(15):3081, 1999. doi:10.1103/PhysRevLett.83.3081.
- [22] William Matthews. A linear program for the finite block length converse of Polyanskiy-Poor-Verdú via nonsignaling codes. *IEEE Trans. Inf. Theory*, 58(12):7036–7044, 2012. doi:10.1109/TIT.2012.2210695.
- [23] Yihui Quek and Peter W. Shor. Quantum and superquantum enhancements to two-sender, two-receiver channels. *Phys. Rev. A*, 95:052329, May 2017. doi:10.1103/PhysRevA.95.052329.
- [24] Felix Leditzky, Mohammad A Alhejji, Joshua Levin, and Graeme Smith. Playing games with multiple access channels. *Nature communications*, 11(1):1–5, 2020. doi:10.1038/s41467-020-15240-w.
- [25] Akshay Seshadri, Felix Leditzky, Vikesh Siddhu, and Graeme Smith. On the separation of correlation-assisted sum capacities of multiple access channels. In *IEEE International Symposium on Information Theory, ISIT 2022, Espoo, Finland, June 26 - July 1, 2022*, pages 2756–2761. IEEE, 2022. doi:10.1109/ISIT50566.2022.9834459.
- [26] Omar Fawzi and Paul Fermé. Beating the sum-rate capacity of the binary adder channel with non-signaling correlations. In *IEEE International Symposium on Information Theory, ISIT 2022, Espoo, Finland, June 26 - July 1, 2022*, pages 2750–2755. IEEE, 2022. doi:10.1109/ISIT50566.2022.9834699.

- [27] Omar Fawzi and Paul Fermé. Multiple-access channel coding with non-signaling correlations. pages 1–1, 2023. doi:10.1109/TIT.2023.3301719.
- [28] Uzi Pereg, Christian Deppe, and Holger Boche. Quantum broadcast channels with cooperating decoders: An information-theoretic perspective on quantum repeaters. *Journal of Mathematical Physics*, 62(6):062204, 06 2021. arXiv:2011.09233, doi:10.1063/5.0038083.
- [29] Siddharth Barman, Omar Fawzi, Suprovat Ghoshal, and Emirhan Gürpınar. Tight approximation bounds for maximum multi-coverage. In Daniel Bienstock and Giacomo Zambelli, editors, *Integer Programming and Combinatorial Optimization - 21st International Conference, IPCO 2020, London, UK, June 8-10, 2020, Proceedings*, volume 12125 of *Lecture Notes in Computer Science*, pages 66–77. Springer, 2020. doi:10.1007/978-3-030-45771-6_6.
- [30] Siddharth Barman, Omar Fawzi, and Paul Fermé. Tight approximation guarantees for concave coverage problems. In Markus Bläser and Benjamin Monmege, editors, *38th International Symposium on Theoretical Aspects of Computer Science, STACS 2021, March 16-19, 2021, Saarbrücken, Germany (Virtual Conference)*, volume 187 of *LIPIcs*, pages 9:1–9:17. Schloss Dagstuhl - Leibniz-Zentrum für Informatik, 2021. doi:10.4230/LIPIcs.STACS.2021.9.
- [31] Uriel Feige, Guy Kortsarz, and David Peleg. The dense k -subgraph problem. *Algorithmica*, 29(3):410–421, 2001. doi:10.1007/s004530010050.
- [32] Paul Fermé. *Approximation Algorithms for Channel Coding and Non-Signaling Correlations*. PhD thesis, Université de Lyon, 2023.
- [33] Noga Alon, Sanjeev Arora, Rajsekar Manokaran, Dana Moshkovitz, and Omri Weinstein. Inapproximability of densest κ -subgraph from average case hardness. *Unpublished manuscript*, 1, 2011. URL: <https://www.tau.ac.il/~nogaa/PDFS/dks8.pdf>.
- [34] Steven J. Brams and Alan D. Taylor. *Fair division - from cake-cutting to dispute resolution*. Cambridge University Press, 1996.
- [35] Hervé Moulin. *Fair division and collective welfare*. MIT Press, 2003.
- [36] Liad Blumrosen and Noam Nisan. On the computational power of iterative auctions. In John Riedl, Michael J. Kearns, and Michael K. Reiter, editors, *Proceedings 6th ACM Conference on Electronic Commerce (EC-2005), Vancouver, BC, Canada, June 5-8, 2005*, pages 29–43. ACM, 2005. doi:10.1145/1064009.1064013.
- [37] Shahar Dobzinski and Michael Schapira. An improved approximation algorithm for combinatorial auctions with submodular bidders. In *Proceedings of the Seventeenth Annual ACM-SIAM Symposium on Discrete Algorithms, SODA 2006, Miami, Florida, USA, January 22-26, 2006*, pages 1064–1073. ACM Press, 2006. URL: <http://dl.acm.org/citation.cfm?id=1109557.1109675>.
- [38] Vahab S. Mirrokni, Michael Schapira, and Jan Vondrák. Tight information-theoretic lower bounds for welfare maximization in combinatorial auctions. In Lance Fortnow, John Riedl, and Thomas Sandholm, editors, *Proceedings 9th ACM Conference on Electronic Commerce (EC-2008), Chicago, IL, USA, June 8-12, 2008*, pages 70–77. ACM, 2008. doi:10.1145/1386790.1386805.
- [39] Kumar Joag-Dev and Frank Proschan. Negative association of random variables with applications. *The Annals of Statistics*, pages 286–295, 1983. doi:10.1214/aos/1176346079.
- [40] Devdatt P. Dubhashi and Desh Ranjan. Balls and bins: A study in negative dependence. *Random Struct. Algorithms*, 13(2):99–124, 1998. doi:10.7146/brics.v3i25.20006.
- [41] Wassily Hoeffding. Probability inequalities for sums of bounded random variables. *Journal of the American Statistical Association*, 58(301):13–30, 1963. doi:10.1080/01621459.1963.10500830.
- [42] F.M.J. Willems. The maximal-error and average-error capacity region of the broadcast channel are identical : A direct proof. *Problems of Control and Information Theory*, 19(4):339–347, December 1990. URL: <https://research.tue.nl/nl/publications/the-maximal-error-and-average-error-capacity-region-of-the-broadc>.
- [43] Bernd Gärtner and Jirí Matousek. *Understanding and using linear programming*. Universitext. Springer, 2007. doi:10.1007/978-3-540-30717-4.

- [44] Jan Vondrák. Optimal approximation for the submodular welfare problem in the value oracle model. In Cynthia Dwork, editor, *Proceedings of the 40th Annual ACM Symposium on Theory of Computing, Victoria, British Columbia, Canada, May 17-20, 2008*, pages 67–74. ACM, 2008. doi:10.1145/1374376.1374389.
- [45] M. R. Garey and David S. Johnson. *Computers and Intractability: A Guide to the Theory of NP-Completeness*. W. H. Freeman, 1979.