



HAL
open science

Robust backbone network based on hybrid selection of relays for multi-hop data dissemination in VANETs

Abdelmonom Hajjej, Marwane Ayaida, Sameh Najeh, Nadhir Messai, Leila Najjar

► **To cite this version:**

Abdelmonom Hajjej, Marwane Ayaida, Sameh Najeh, Nadhir Messai, Leila Najjar. Robust backbone network based on hybrid selection of relays for multi-hop data dissemination in VANETs. *Vehicular Communications*, 2023, 44, pp.100659. 10.1016/j.vehcom.2023.100659 . hal-04232721v2

HAL Id: hal-04232721

<https://hal.science/hal-04232721v2>

Submitted on 9 Mar 2024

HAL is a multi-disciplinary open access archive for the deposit and dissemination of scientific research documents, whether they are published or not. The documents may come from teaching and research institutions in France or abroad, or from public or private research centers.

L'archive ouverte pluridisciplinaire **HAL**, est destinée au dépôt et à la diffusion de documents scientifiques de niveau recherche, publiés ou non, émanant des établissements d'enseignement et de recherche français ou étrangers, des laboratoires publics ou privés.

Robust Backbone Network Based on Hybrid Selection of Relays for Multi-hop Data Dissemination in VANETs

Abdelmonom Hajjej^{a,c}, Marwane Ayaida^{*,b,c}, Sameh Najeh^a, Nadhir Messai^c and Leila Najjar^a

^aUniversity of Carthage Higher School of Communications of Tunis COSIM Research Lab Tunis Tunisia

^bIEMN UMR CNRS 8520 Universit  Polytechnique Hauts-de-France 59300 Valenciennes France

^cUniversit  de Reims Champagne Ardenne CReSTIC EA 3804 51097 Reims France

ARTICLE INFO

Keywords:

Vehicular networks
VANETs
Data dissemination
Backbone
Relay nodes
Multi-hop Broadcasting

ABSTRACT

Relay nodes selection as a key word to ensure efficient multi-hop data dissemination in VANETs has received tremendous attention for many years. However, previous literature often fails to address two critical topics. Firstly, the conception of a reliable relay distribution model to ensure information coverage without generating additional overheads. Secondly, the simultaneous exploit of both existing sender-oriented and receiver-oriented relay selection mechanisms to avoid the trade-off among them and improve the overall dissemination efficiency. In this paper, we propose a Robust BACKbone NETwork based on Hybrid Selection of Relays for multi-hop data dissemination in VANETs (BACKNET-HSR). Its novelty lies in adequately addressing the aforementioned topics. To avoid the chaotic distribution of relays and enhance information coverage, we adjust the relay selection and inhibition rules according to a novel concept of message propagation pattern. The goal is to realize a synergy among the potential relay candidates to build an on-the-fly backbone network parallel to the road lines topology in a distributed manner. With the aim of enhancing the relay selection robustness, we propose a tight coupling of both investigated relay selection mechanisms in one hybrid scheme. The objective is to leverage the low latency feature of the sender-oriented mechanism, and the high reachability feature of the receiver-oriented mechanism. Simulation results show that the proposed scheme disseminates data with low delay and high information coverage, outperforming the existing dissemination protocols in different scenarios and under varying vehicular densities.

1. Introduction

The ever-growing number of vehicles combined with the unprecedented technological progress pose a serious interest from researchers and recent automotive markets in the emerging Vehicular Ad-hoc NETWORKS (VANETs). VANETs open up the possibility of the connected car concept through enabling a Vehicle-to-Everything (V2X) communication paradigm, which can boost the development of numerous Intelligent Transportation Systems (ITS)-based applications ranging from entertainment to safety-related, including navigation and infotainment services (1; 2). Realizing cooperative communications between vehicles without the need of the coordinator entities, e.g., Road Side Unit (RSU), is among the primary motivations of VANETs since they help to reduce the economical cost of the connected cars implementation, as well as avoiding some intrinsic problems brought by the use of a centralized network manager, such as the channel competition and packets congestion problems. To achieve this goal, each vehicle in VANETs is assumed to be equipped with a Dedicated Short-Range Communication (DSRC) (3) device, making it able to directly exchange information with its nearby neighbors, e.g., the exchange of

Basic Safety Message (BSM) (4) or Cooperative Awareness Message (CAM) (5).

In VANETs, some information are recognized as data for the public interest, where their real-time delivery could significantly enhance the traveling experience (6; 7), and especially boost the road safety applications by extending the knowledge bases of vehicles with numerous up-to-date information about various road conditions. The main challenge in this field arises from the fact that the sent data should be disseminated in a wide Area-of-Interest (AoI), while the sending vehicles are equipped with the limited DSRC devices. In order to handle this challenge, one promising technique is to allow messages to be spread over multiple depots in an ad hoc manner through a Vehicle-to-Vehicle (V2V) communication. However, Considering some intrinsic Inter-Vehicular Communication (IVC) (3) characteristics, it is obvious that the multi-hop retransmission paradigm is not mature enough to provide reliable dissemination process in VANETs. Indeed, due to the shared data load, vehicular traffic density, the lack of a coordinator entity to manage the channel allocation and contention, and the limited radio medium dedicated for VANETs (1), serious broadcast storm and packet collisions threat the availability and timeliness of the network. Reducing the communication burden by enabling only a subset of vehicles to relay the sent messages (referred to as relay nodes) has long been debated to be efficient solution for reducing data redundancy and wireless channel damage (8; 9; 10; 11; 12). Nevertheless, it still hard to design a robust relay selection technique that can handle the characteristics of VANETs in a fully distributed manner

* Note: Preprint submitted to Vehicular Communications Volume 44, December 2023.

** <https://doi.org/10.1016/j.vehcom.2023.100659>

*Corresponding author

✉ abdelmonom.hajjej@supcom.tn (A. Hajjej); marwane.ayaida@uphf.fr (M. Ayaida*); sameh.najeh@supcom.tn (S. Najeh); nadhir.messai@univ-reims.fr (N. Messai); leila.najjar@supcom.tn (L. Najjar)

ORCID(s):

(2). For instance, the high-speed of vehicles induces a fast-changing network topology and frequent disconnection of the wireless communication links, resulting in a poor network reachability. This will lead to a serious packet loss problem and becomes more severe when increasing the network complexity. For example, the physical obstacles in the complex urban scenarios can easily intersect the transmitted signal and block the end-to-end communications (13).

Designing a robust relay selection algorithm is a unique problem for disseminating messages in VANETs, a poor selection of relays can easily lead to a poor reachability and message coverage capability, high latency, and even to the reproduction of the broadcast storm (14). In general, existing relevant works address the issues of data dissemination in VANETs in two different ways (15). Some exploit the one-hop neighbors information gathered by means of the beacon messages to explicitly select the relay nodes at the sender side, referred to as sender-oriented relay selection mechanism; and others aim to improve the network reachability and avoid the beacon exchanging cost by adopting an implicit selection of relays, referred to as receiver-oriented relay selection mechanism. Each mechanism has its unique benefits and shortcomings, thus its own problems that are driving the research aspects. For example, sender-oriented schemes can achieve a rapid propagation of messages, but they are very sensitive to the mobility of vehicles. On the other hand, receiver-oriented schemes exhibit high tolerance with the high speed of vehicles, but with an extra transmission delay. Besides, regardless of whether the relay selection is sender-oriented or receiver-oriented, it should be noted that the geometric distribution of relays almost determines the message coverage efficiency. The selected relays should be adequately distributed inside the targeted dissemination area to ensure an optimal coverage of the entire AoI. Nevertheless, we observed that this requirement have not been effectively addressed in most of the existing dissemination protocols, incurring the chaotic distribution of relays and resulting in a poor information coverage. Instead of the flat network structure, creating a network hierarchy in VANETs can bring significant advantage for the data delivery by managing the message retransmissions process in a structured manner. Meanwhile, there are other challenges over a dynamic VANET topology, especially, the maintenance and creation of stable network structure with less overheads (16).

In light of the above description, this paper is proposed with the aim to construct a Robust BACKbone NETwork based on Hybrid Selection of Relays for multi-hop data dissemination in VANET, namely as BACKNET-HSR. Robustness is achieved by adequately addressing a series of data dissemination issues stemming from the unique characteristics of VANETs, including low information coverage, frequent disconnection among neighboring relays, expanded latency, unexpected packets loss, and the lack of a centralized network manager in VANETs. To realize this, we first envisaged a new relay distribution model able to enhance both information coverage and connectivity among relays. In

order to fit the distributed nature of VANETs, we introduce a new message propagation pattern as the guidance of the relay selection and inhibition rules. In this way, each vehicle makes its own decision on relaying the message based on the fulfillment of the message propagation pattern within its transmission range. Moreover, we address reachability and expended latency issues by realizing a tight coupling of both existing sender-oriented and receiver-oriented relay selection mechanisms in one hybrid scheme. To sum up, the key contributions presented by this paper can be summarized as follows:

- 1) This paper gives out a deep overview of sender-oriented and receiver-oriented relay selection mechanisms, as well as a qualitative comparison among them.
- 2) We construct an on-the-fly backbone network parallel to the road lines topology to realize a relay distribution model able to deliver messages to all intended vehicles.
- 3) We introduce a novel message propagation pattern to realize a synergy among potential relay candidates for constructing the investigated backbone network in a distributed manner.
- 4) Instead of exclusively adopting a single relay selection mechanism, we propose an ordered combination of sender-oriented and receiver-oriented relay selection mechanisms in one hybrid scheme.
- 5) We define different timer settings to ensure the ordered combination of both adopted mechanisms.

The remainder of this paper is organized as follows: Section 2 investigates existing literature on data dissemination in VANETs, explores the research challenges and gaps in the previous related works. Section 3 gives the key aspects of the proposed scheme. Section 4 presents the proposed scheme in detail. The simulation results are analyzed in section 5. Finally, the last section provides a brief overview of our future work and concludes this work.

2. Background

Multi-hop data dissemination is among the main research topics of VANETs in previous literature (2). Flooding has long been exhibited as the simplest way of disseminating data over the mobile ad hoc networks, each vehicle roaming inside the AoI broadcasts every incoming message once. Although the blind flooding has high performance efficiency under the sparse network scenarios, it disrupts the network availability by generating the broadcast storm problem when increasing the network density. Hence, it easily lead to a serious network congestion and packet collisions (14; 16). In order to mitigate these problems, previous relevant works tend to adopt such a broadcast suppression technique (16) to avoid the unnecessary retransmissions. Only a subset of potential vehicles will be enabled to relay the disseminated data, while the others will be inhibited. At this point, it should be noted that a poor selection of the relay nodes will undoubtedly undermine the dissemination efficiency in many regards, such as latency, overheads, and particularly the message coverage capability (14). Next, we will provide a detailed description of the relay selection mechanisms.

This will be followed by an examination of existing dissemination protocols, and finally, we give a qualitative comparison study among these protocols while highlighting the novelty of our proposed scheme.

2.1. Relay selection mechanisms

As described earlier, based on either the relay selection process is performed by the sender or the receiver nodes, existing broadcast suppression techniques can be classified into two main classes: sender-oriented and receiver-oriented relay selection mechanisms. The former can be referred to as beacon-assisted relay selection mechanism. It exploits the one-hop neighbors information gathered by means of the exchanged beacon messages to explicitly select the next-hop relays at the sender side. The current relay node should elect among its vicinity one or more neighbors to become the next dissemination entities, incorporates their identifiers inside the message and broadcast. When receiving the sent message, each receiver first needs to judge whether or not it has been explicitly selected to become a relay node by checking the content message relay list. If yes, it will forward the message; else, it will be inhibited. As this type of mechanism provides the possibility of a continuous retransmissions at the application layer, sender-oriented solutions achieve promising performance in network latency, which can promote the development of the delay-sensitive applications (14). However, they exhibit high sensitivity to the frequent disconnection of the communication links in VANETs. In fact, considering the high mobility of vehicles, the presence of physical obstacles, the channel fading operation, the hidden nodes problem, etc., there is no guarantee that the explicitly selected relays (i.e., the only ones enabled to broadcast) will correctly receive the sent message. Hence, a high packet loss is possible in this case.

While sender-oriented solutions faced the most intrinsic VANET challenge, i.e., the severe packet loss stemming from the frequent disconnection of the communication links, other research studies were proposed with the aim to fully overcome this issue by using a receiver-oriented relay selection mechanism. The main idea behind this mechanism is to enable an implicit selection of relays through the use of the contention concept, which does not require any prior knowledge about the surrounding network conditions, e.g., the neighbor location, the already established link connections, etc. For this reason, receiver-oriented solutions are known as beaconless approaches, where their main advantage is usually referred to dispensing the beacon exchanging load (17; 18). Although this benefit is valid in the dissemination context, it should be noted that beacon messages have been standardized by the European Telecommunications Standards Institute (ETSI) as a cornerstone of the cooperative awareness service (5), particularly for the safety-related services. In reality, the main purpose of the receiver-oriented mechanism is to fit the fast-changing VANET topology by avoiding the link condition dependency when designing the relays selection rules. In other words, the vehicle makes its

own decision on whether or not it relays each received message in a fully distributed manner. For every incoming message, the vehicle holds it and initiates a transmission timer, usually computed based on the distance from the previous hop relay. If the initiated timer expires, the vehicle becomes a relay node and broadcasts the message. Data redundancy has been effectively mitigated by forcing vehicles to immediately canceling their scheduled transmissions upon hearing new transmission of the same scheduled message (inhibition rule). Receiver-oriented mechanism has a promising preference in terms of reachability, it effectively mitigates the effects of mobility and link failure problems. However, it involves the use of a back-off timer at the application layer, which leads to an intermittent retransmission paradigm and noticeably expands the dissemination latency, particularly as we exploit the multi-hop retransmission paradigm over a large scale VANET network.

2.2. Related work

Next, we will begin by reviewing varying data dissemination protocols specifically designed for VANETs, then we will provide a qualitative comparison among these protocols listed in Table 1. In general, to effectively mitigate the broadcast storm issue, existing literature commonly uses the distance between vehicles as the primary metric for relay selection. The neighbor that is farthest away from the sender is recognized as the ideal next-hop relay. While the longest distance metric can efficiently deal to the unnecessary retransmissions problem by reducing the number of relay nodes, it exacerbates reachability among relays. This is due to the fact that, considering the mobility of vehicles and the channel fading operation, the higher the distance between a pair of connected vehicle, the more unstable the associated link connection. To deal with the latter problem, a Bi-directional Stable Communication (BDSC) scheme has been proposed in (12). The goal is to improve both reachability and coverage. First, the stability of link connection is estimated based on the regularity of the incoming beacons. After that, a relay priority list containing 12 potential neighbors is constructed. Upon becoming a relay node, the vehicle incorporates its own relay priority list inside the message and broadcasts it. Simultaneous retransmission is effectively addressed by using a contention-based retransmission paradigm. Data redundancy is also addressed by forcing the explicitly selected relays to cancel their scheduled transmissions upon hearing a twice copies of the same message. Two variants of BDSC scheme have been proposed in (14). The main idea behind these variants was to combine multiple selection metrics when constructing the relay priority list, particularly distance and link stability influence factors. Thus, this achieves better performance than the original BDSC scheme in terms of latency and overhead. The main drawback of these schemes is the generation of a chaotic distribution of relays, since they are exclusively focusing on the stability of wireless links.

While the link stability cannot adequately characterize the quality of links in VANETs. The work in (19) estimated the link quality by computing the successful transmission pr-

Table 1
A comparative analysis of data dissemination protocols

ID	Objective	Scenario	Relay selection mechanism	Relay selection metrics	Coverage consideration	Advantages
(14)	Prevent link disconnection by constructing stable bi-directional communication links, and avoid the broadcast storm problem	Urban	Sender-oriented	Link stability, computed based on the regularity of the incoming beacons	Adopt a multiple selection of next-hop relays to ensure the dissemination of messages across multiple directions	Improve reachability and information coverage while still guaranteeing low latency
(16)	Improve the cluster lifetime, and reduce the inter-clusters communication cost	Highway	Sender-oriented	Probabilistic approach, each node forward with a computed probability associated with the message redundancy ratio	Adopt an hierarchical retransmission paradigm through the construction of clusters	Good performance in terms of information coverage while minimizing redundancy
(13)	Provide an obstacle less forwarding algorithm, and enhance the relay selection robustness	Urban	Sender-oriented	Implement a fuzzy logic technique for optimizing the relay selection process, considering three evaluation metrics: distance, velocity, and SIR	Utilizing a hybrid approach that combines the shortest path algorithm with the Delaunay triangulation algorithm to optimize the routing path construction process	Leveraging real physical environment parameters to mitigate channel fading operation, enhance delivery ratio in city driving conditions, and minimize the response time
(20)	Improve the cluster lifetime, and maintain stable inter-clusters communication	Urban	Sender-oriented	Link stability, computed based on the relative average velocity and distance	Adopt an hierarchical retransmission paradigm through the construction of clusters	Good information coverage, maintain the stability of clusters through the use of multiple clustering metrics, and limit the packet loss during the inter-cluster message passing
(21)	Reduce the beacon load, solve the hidden node and broadcast storm problems	Urban, and Highway	Sender-oriented	Distance and local density	Assign priority to the neighbors with higher local densities to become the next-hop relays	Robust against varying traffic conditions, effective use the resource channel, and good network latency
(22)	Extend the basic idea of regular sender-oriented mechanism through the use of auxiliary relay to reinforce information coverage	Urban, and Highway	Sender-oriented	Not specified, it has been presented as an extension of any sender-oriented scheme	Select an auxiliary relay in addition to the explicitly selected relay	Enhance information coverage without incurring significant additional overhead
(23)	Developing a cooperative dissemination strategy for efficiently spreading big-volume video alert messages across a heterogeneous V2V network	Highway	Sender-oriented	Distance, relative speed, Rician factor, and utility factor	Besides to the adopted hierarchical retransmission paradigm, an utility factor is introduced to assign priority to the relay candidates with large amount of Scalable Video Coding (SVC) cache	Deal with the heterogeneity of vehicles, exploit the Instantly Decodable Network Coding (IDNC) technology for better utilization of the limited bandwidth
(8)	Mitigate the broadcast storm problem	Highway	Receiver-oriented	Distance from the sender	Allow redundancy in specific regions to achieve information coverage	Different broadcast suppression techniques are proposed to minimize unnecessary retransmissions, good performance in terms of information coverage and MAC delay in dense network scenario
(24)	Improve the work presented in (8), minimize redundancy, and handle the network disconnection issue	Highway	Receiver-oriented	Distance from the sender, and mobility direction	Allow redundancy in specific cases, and adopt the store-carry forward technique in sparse network scenario	Operate in varying traffic densities, Minimize channel congestion as respect to (8) while still guaranteeing similar information coverage
(10)	Handle the interest flooding problem through a density approximation-based probabilistic relay selection scheme	Urban	Receiver-oriented	Approximated local traffic density and distance	Adopt a redundancy tolerance threshold, enabling each vehicle to broadcast the interest as long as it has been received once	Develop new method to estimate the local traffic density based on the PIT entry, Handle the simultaneous retransmission problem, and improve reachability
(11)	Mitigate both the broadcast storm and network partitioning issues	Urban, and Highway	Receiver-oriented	Timer-based approach, taking into account the sender's distance and the vehicle's current location	Introduce a sweet-spot concept that facilitates the distribution of messages across four distinct directions	Support diverse traffic conditions, good information coverage
(9)	handle the link disconnection problem, and minimize the unnecessary retransmissions	Urban	Receiver-oriented	Fundamental timer-based approach, only the distance from the sender is considered	Adopt a redundancy tolerance threshold, enabling each vehicle to broadcast the message as long as it has been received once	Limit message redundancy with less computation overheads, and ensure reachability
(18)	Avoid the simultaneous retransmission problem of CBF (9)	Urban	Receiver-oriented	The same CBF timer settings while including an uniformly-distributed timer component	No improvement compared to the original CBF	Reduce the channel congestion, and enhance the efficiency in terms of delivery ratio
Proposed BACKNET-HSR	Leveraging the best feature of both existing sender-oriented and receiver-oriented mechanisms, and realizing an hierarchical retransmission paradigm without inducing additional overheads (i.e., on-the-fly hierarchy)	Urban, and Highway	Hybrid: sender-oriented and receiver-oriented	Distance factor, link straightness factor, and message propagation direction	Adopt an hierarchical retransmission paradigm through the construction of an on-the-fly backbone network	Ensure the low dissemination delay of the sender-oriented mechanism, the high reachability of the receiver-oriented mechanism, and the high information coverage of the hierarchical retransmission paradigm without generating extra-overheads

bability over that link. A link model has been proposed to estimate the link availability based on signal fading and mobility characteristics. In the protocol, an opportunistic routing is proposed to fit varying mobility and urban scenarios. In the same context, the work in (13) mitigates the signal fading issue through the use of an obstacle avoidance forwarding strategy. Delaunay Triangulation algorithm is exploited to establish robust forwarding paths without intersecting the physical obstacles within the roadsides. During the dissemination process, fuzzy logic is applied to evaluate the priority of the relay candidates based on euclidean-distance, signal-to-interference Ratio (SIR), and relative velocity. The major drawback of the latter scheme lies in the fact that removing Torricelli points from Delaunay Triangulation, i.e., line of sight determination, incurs high computation load.

The improvement of information coverage is also within interest of existing literature. The goal is to enhance the message coverage capability by maximizing the number of vehicles receiving the message. The use of a network hierarchy to overcome the limitations of the flat network structure of VANETs can efficiently deal with the chaotic distribution of relays in data dissemination protocols. The clustering-based approaches can be recognized as representative solutions for attempting such a network hierarchy, like in (16; 20). Vehicles are organized into multiple connected clusters, and each cluster is managed by a controller entity named cluster-head. During the dissemination process, messages will be routed toward the cluster-heads, then forwarded towards the cluster-members in a hierarchical manner. The main drawback of these solutions is that the formed hierarchy should be stable to ensure the structured propagation of the sent messages, which is hard to be realized in a time-varying VANET topology. Thus, any topology changes should be reported to all relevant nodes, incurring an important communication overheads. In (20), cluster instability has been mitigated by increasing cluster-head lifetime. A group of vehicles elect their associated cluster-head based on various mobility metrics, including mobility direction, speed, and time to leave. To enhance reachability, the cluster-head prioritizes the cluster members within line of sight to relay the message across adjacent clusters. This scheme can solve the instability of clusters and reduce the cluster maintenance cost. However, it does not adequately address the inter-clusters communication challenges.

A probabilistic broadcasting within a hierarchical network has been proposed in (16). With the aim to create a stable clustering algorithm, vehicles having similar driving direction are grouped within the same cluster. Reachability is achieved by assigning priority to the vehicles with high transmission probability to become cluster-heads. The major novelty of this scheme is the use of a probabilistic inter-clusters communication paradigm to reduce the unnecessary retransmissions during the dissemination process. Rather than selecting a fixed number of relays as in (20), each relay candidate computes its own broadcast probability based on the received message redundancy. Thus, the number of

selected relays is dynamically adjusted to fit the variation of traffic densities.

The work in (21) takes into account the local density of each vehicle during the relays selection process. The neighbor that has a high local density and falls farther away from the sender is more likely to become the next-hop relay. A path diversity broadcasting solution is proposed in (22). Instead of selecting only one relay, an auxiliary relay is selected to reinforce the message delivery capability. In order to reduce the redundancy, the auxiliary relay will only broadcast the sent message without performing the relay selection process. By increasing the dissemination constraints, other solutions tend to achieve robust relay selection process under complex scenarios. Some works have been proposed to disseminate heavy accident video alerts while considering the heterogeneity of vehicles (23); and others consider the security constraints when selecting the relay nodes (25).

Two popular probability-based schemes have been proposed in (8), where each vehicle broadcasts the message with a certain forwarding probability associated with the distance and redundancy relay selection metrics. In the first scheme, namely as Weighted-p, the forwarding probability of vehicles increase linearly with the distance from the sender. Although simultaneous retransmissions problem has been mitigated by enabling a scheduling process whenever a duplication of the same message is received, multiple unnecessary retransmissions are generated due to the lack of an inhibition rule. The second scheme, namely Slotted p-persistence, is mainly proposed to reduce the message redundancy problem of p-persistence. The transmission radius of the sender is divided into several regions, and each region is associated with a back-off timer. Only the vehicles within the farthest region from the sender are enabled to broadcast with a Weighted-p probability, the other are inhibited. However, message redundancy problem still occur, since multiple vehicles can be located within the same region. Additionally, due to the time-varying traffic flow, it is a challenging task to accurately define the back-off timer associated with each region.

Literature presents multiple approaches aimed to extend the concept of probabilistic broadcasting (26; 27; 24; 10). A comprehensive survey of probabilistic broadcasting schemes can be found in (28). The work in (24) addresses the issue of message redundancy in (8) by combining the farthest distance algorithm with the mobility of vehicles. It assigns the highest broadcast probability to the receivers far away from the sender and have similar movement direction, which could reduce the number of contending vehicles. The applicability of a probabilistic broadcasting scheme to varying vehicular traffic densities has been also studied in (10), revealing that adjusting the forwarding probability with the local density of vehicles could enhance the coverage capability with less communication burden. An approach to improve the reliability of the probabilistic forwarding consists of using fuzzy logic to calculate the broadcast probability of vehicles by taking into account the buffer load, angular

orientation, and the movement direction of each vehicle (27). Similar to (16), the work in (26) proposes the use of a clustering algorithm to improve information coverage. In order to reduce message redundancy while ensuring low latency, a new index-based broadcasting probability is proposed to dynamically adjust the forwarding probability according to the relative distance among vehicles.

Probabilistic schemes can provide a continuous retransmission paradigm at the application layer, which ensure a low dissemination latency. However, they lead to severe packet collisions and channel damage due to the simultaneous rebroadcasts from nearby nodes (multiple neighbors can have high broadcast probability of the same message, especially in dense VANET scenarios). Timer-based solutions (11; 9; 18; 17) have gained important attention in the recent years. They were exhibited as promising alternatives of the probabilistic schemes, since they effectively address the issue of the simultaneous rebroadcasts through the use of contention.

DRIVE (11) introduces a sweet spot concept to maximize the message coverage capability under varying traffic conditions. The communication radius of the sender vehicles is divided into four quadrants, a sweet spot is defined in each quadrant as the most suited zone in which the next hop relay should be located. DRIVE aims to maximize the coverage capability by assigning the lowest contention-timer to the farthest vehicle within each sweet spot. However, the authors in DRIVE do not adjust their proposed inhibition rule to fit the sweet spot concept, instead they adopt the indiscriminate inhibition (detailed in the next sub-section), which disrupts the envisioned relays distribution model and easily lead to the chaotic distribution of relays. Additionally, an extra delay is induced by the adopted timer settings since there is no guarantee to find vehicles located within the sweet spots (i.e., the ones with the shortest transmission-timers).

A Contention-Based Forwarding (CBF) algorithm (9) is proposed by the ETSI as the current standard of data dissemination in VANETs. CBF can be seen as an improved version of DRIVE. Instead of the sweet spot concept, CBF enables vehicles receiving one copy of the sent message to become relay nodes, realizing an on-the-fly relays distribution model dynamically adjusted to fit the senders' neighbors distribution. This perception enables CBF to adopt an uniform timer setting, the furthest receiver from the sender is assigned with the shortest transmission timer independently of the zone where it is falling inside. Although CBF achieves much better performance in network latency compared to DRIVE, it stills suffer from the intermittent retransmission problem since there is no guarantee to find neighbors distant enough from the senders to ensure the rapid propagation of messages, especially under the sparse network scenario. In contrast, in dense scenario, CBF generates frequent simultaneous retransmissions since, in this particular scenario, there is a high probability to find equidistant neighbors from the sender, i.e., neighbors with equal transmission timers. Moreover, like DRIVE, CBF adopts the indiscriminate inhibition

rule, leading to the fail of the considered relays distribution model under multiples vehicular scenarios.

A pull-based data dissemination approach has been proposed in (18) to aggregate real-time Floating Car Data (FCD). To disseminate the request messages, the authors in (18) propose a reduced CBF (rCBF) to overcome the simultaneous retransmissions induced by the original CBF. The main idea behind rCBF is to extend CBF's timer setting with an uniformly-distributed random component, hence avoiding the simultaneous retransmissions in case of equidistant neighbors from the sender, but with an extra delay. Several timer-based approaches have been proposed in the literature, they are mainly focusing on the high delay issue steaming from the contention process (29; 30), the collision problem that frequently occurred in case of defining short timer difference among neighboring receivers (31), and the applicability of the timer-based approaches with the Decentralized Congestion Control (DCC) buffer (17; 32). In this regard, it should be noted that the information coverage has not so far been effectively addressed in previous literature.

2.3. Research challenges, gaps, and comparative analysis

In VANETs, the addressed challenges of data dissemination are stemming from the adopted relay selection mechanism. Each mechanism has its unique benefits and drawbacks, thus its own challenges that are driving the research aspects. A qualitative comparison among sender-oriented and receiver-oriented relay selection mechanisms is listed in Table 2. Since sender-oriented solutions emphasize the availability of the explicitly selected relays, ensuring reliable communication links among relays to enhance reachability is a unique challenge in these solution. To do this, several relay selection metrics have been introduced in the literature, including link connectivity (16), link life time (20), successful transmission probability (19), and signal fading (13). Otherwise, latency has not been addressed in most of the existing sender-oriented solutions. This is mainly due to the fact that the explicit selection of relays is recognized as the fastest way to spread data over a wireless ad-hoc network. Information coverage problem has been addressed in different ways. Some works propose the assignment of high rebroadcast priorities to the relay candidates with dense local network as in (21), and others aim to extend the coverage capability by selecting auxiliary relays as in (22; 12; 14). However, due the volatility of traffic density and the lack of an efficient inhibition rule, these solutions may not be sufficient to ensure information coverage. A more efficient technique to ensure coverage is the use of a network structure instead of the flat structure commonly found in VANETs (16; 20). Meanwhile, maintaining available structure over a mobile network incurs substantial costs in terms of generated overheads.

On the other hand, receiver-oriented approaches do not face the reachability issue. However, new challenges have emerged, especially in terms of expended latency and simultaneous rebroadcasts. Hence, relevant works are mainly proposed with the aim to mitigate these challenges. Handling the expanded latency through the use of a probabilistic-based

Table 2

Comparative study of sender-oriented and receiver-oriented relays selection mechanisms.

Features	Sender-oriented mechanism	Receiver-oriented mechanism
Relays selection rule	Explicit selection of relays – Before each broadcast, the sender vehicle should select the next hop relays and incorporate their identifiers inside the disseminated message.	Implicit selection of relays – Upon receiving the message, the vehicle should hold it and schedule a back-off timer. The vehicle relay the message once the initiated timer expires.
Inhibition rule	Only the receivers finding their identifiers incorporated inside the sent message are allowed to broadcast, the other are inhibited.	Each node that hear retransmission of an already scheduled message must immediately cancel its transmission.
Advantages	Enables a continuous retransmission paradigm at the application layer, which can promote the development of the delay-sensitive applications. Provides a good scalability when designing the relay selection rules (14).	Exhibits good tolerance with the frequent disconnection of the communications links between mobile vehicles. No prior information are required to perform the dissemination process (beaconless solution).
Drawbacks	Exhibits high sensitivity to the frequent disconnection of the communication links in VANETs. Requires up-to-date information about the one-hop network condition (beacon-assisted solution).	Adopts an intermittent retransmission paradigm that noticeably increase the latency. Not recommended for the delay-sensitive applications.
Frequent addressed challenges	Handling the broadcast storm problem. Maintaining reachability. Enhancing the information coverage capability.	Handling the broadcast storm problem. Handling the expanded latency. Preventing the simultaneous retransmissions problem. Enhancing the information coverage capability.

solution as in (26; 8; 10; 27; 24), or the reduction of the contention timers in timer-based approaches as in (9; 18; 29; 30) are widely studied. The issue of packets collision resulting from simultaneous retransmissions has received significant attention, particularly in the Probabilistic-based solutions. One commonly used technique to address the latter issue is the use of additional parameters other than distance when computing the forwarding probability, as demonstrated in (27; 10). However, this issue has not been adequately studied in the context of timer-based solutions. While the extension of contention timers by an additional slots has been investigated in (18), these approaches have resulted in an extra delay. Few receiver-oriented solutions address the information coverage challenges, such as the sweet spot concept introduced in DRIVE (11) and the density-aware approach discussed in (10). Meanwhile, these solutions emphasize on the fulfillment of certain assumptions, including the presence of vehicles within the sweet spots in (11) or locating neighbors with high local density in (10); else, they result in an expanded latency.

Unlike routing, where the relay selection process involves selecting a subset of intermediate vehicles to realize a transmission path between the source and the intended destination vehicles, the objective of relay selection algorithms in data dissemination schemes is to avoid the broadcast storm problem. Only a subset of potential vehicles are enabled to broadcast the message, while the other should be inhibited. Therefore, the selected relays must be adequately distributed inside the targeted AoI to ensure the coverage of all intended vehicles. However, to the best of our knowledge, existing dissemination schemes have overlooked the importance of an efficient relay distribution model during the design of the

relay selection and inhibition rules. This becomes evident when considering that the commonly adopted inhibition rule emphasizes exclusively on the information redundancy, i.e., vehicles that receive twice copies of the same message are inhibited to broadcast. While this inhibition rule efficiently deals with the broadcast storm, it easily leads to an indiscriminate inhibition of the relay candidates, hence a chaotic distribution of the selected relays. For the sake of simplicity, a representative illustration of this problem is shown in Fig. 1. Regardless of whether the adopted relay selection mechanism is sender-oriented or receiver-oriented, in this figure, we consider the case of multiple selection of next hop relays (9; 11; 14; 12; 18) as they achieve better information coverage compared to the others solutions. Assuming that a Source Vehicle SV initiates the dissemination process by broadcasting a warning message, vehicle V1 will be the first one that rebroadcasts the sent message since it has the farthest distance from SV. Assuming that vehicles V4, V7, V6 and V10 are the farthest from each other, hence they will be respectively the third, fourth, fifth and sixth re-broadcaster nodes. As seen in this example, vehicles V2, V5, V8 and V11 are a very critical relay candidates since they are the only ones that could forward the sent message towards the bottom network side. However, since each one of them will receive at least twice copies of the sent message, they will be indiscriminately inhibited. Therefore, the vehicles V12-V19 will not receive the sent message even-though they are considered as belonging to the targeted AoI, which leads to the poor coverage capability. The indiscriminate inhibition issue has been addressed in the area advanced forwarding algorithm (9), proposed by the ETSI, by increasing the redundancy tolerance ratio. Vehicles

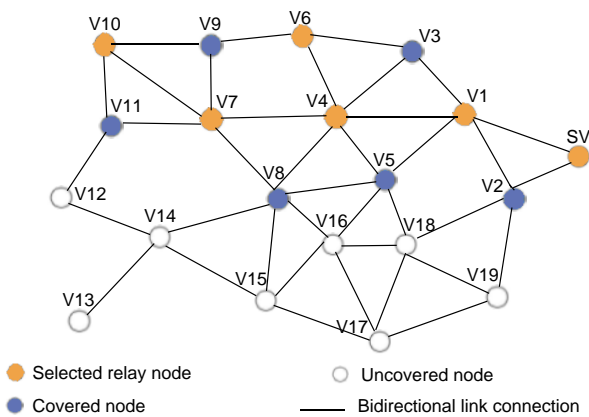

Figure 1: Effects of the indiscriminate inhibition rule on the information coverage capability

receiving redundant copies of the same message less than a given inhibition threshold will be allowed to broadcast. However, the limited DSRC channel will be overwhelmed by the unnecessary retransmissions of redundant messages. Additionally, As shown in Fig. 1, it is a challenging task to define the optimal inhibition threshold under a time-varying vehicular distribution and density.

In view of the above description, the novelty of our proposed dissemination scheme can be generalized as follows:

1) *Network reachability and timeliness:* In contrast to the aforementioned data dissemination solutions that were operated exclusively based on either a sender-oriented or receiver-oriented relay selection mechanisms, we propose a tight coupling of both mechanisms to enhance reachability and reduce latency. First, we implemented a sender-oriented relay selection algorithm to enable an explicit selection of relays, hence, ensuring low dissemination latency. Connectivity among neighboring relays has been considered by taking into account two factors: (1) the mobility of vehicles, which is addressed by assigning priority to the relay candidates within an optimal distance to ensure sustained connection over a period of time, and (2) the effects of channel fading, which is mitigated through an obstacle-avoiding forwarding strategy that prioritizes the relay candidates located within an obstacle-less area. Since connectivity can not be definitely ensured through the usage of an explicit selection of relays, unexpected packet loss may occur. To avoid this issue, we adopt a new monitoring algorithm inherited from the receiver-oriented mechanism. Vehicles that were not explicitly selected to relay the message will monitor its propagation. Upon capturing a link disconnection problem, the most suitable one will compensate for the lost packet by relaying the message. In this way, we leverage the best features of both investigated mechanisms to avoid the trade-off among them and enhance the overall dissemination efficiency.

2) *Message coverage capability:* A promising technique to address information coverage in existing dissemination

schemes is the use of a network structure, especially a clustering algorithm. Although this technique brings a significant enhancement in terms of coverage capability, it comes with the drawback of significant additional overheads resulting from the structure creation and maintenance cost, particularly as we deal with a fast-changing VANET topology. In our proposed scheme, we leverage the fact that vehicles are distributed within a road map topology, hence a partisan vehicular distribution along the road lines is automatically formed. Additionally, since each road segment can be treated as a one-dimensional plane (33), it becomes evident that message propagation can be exclusively conducted in two directions along the road line. In order to fit the distributed nature of VANETs, we propose a novel message propagation pattern as the guidance of the relay selection and inhibition rules. Each vehicle could make its own decision on the relay selection process based on the fulfillment of the message propagation pattern within its communication range. In other words, a synergy among potential relay candidates is realized to build an on-the-fly backbone network along the road lines. Thus, this allows to achieve a structured relay distribution model in a fully distributed manner and without introducing any additional overhead.

3. Key Aspects of BCKNET-HSR

In this section, we will give out an overview of the proposed data dissemination scheme by presenting the following aspects.

3.1. Assumptions

1) All vehicles are equipped with DSRC devices with equidistant communication ranges, storage unit, static digital map, and a positioning system (on-board GPS). The GPS information are assumed to be sufficiently accurate to enable vehicles to determine their positions on the roads. In this way, each vehicle could determines its own position, velocity, and get information about the road network topology.

2) Each vehicle periodically broadcasts a beacon message that includes pertinent information, such as its unique identifier, position, and speed. The receiver vehicles update their neighbor tables based on the information retrieved from the beacon message and consider the originator vehicle as a one-hop neighbor.

3) The transmission range of vehicles is larger than the width of the roads.

4) Only the Vehicle-to-Vehicle (V2V) communication paradigm is considered, which means that there is no need to deploy Road Side Units (RSUs) along the roadside.

5) All vehicles are assumed to be honest.

Notice that assumptions 1 and 2 have been referred by the ETSI (5; 34). The standard form of beacon messages is the Cooperative Awareness Messages (CAMs) (5), which are exchanged periodically and maintained in the Local Dynamic Maps (LDMs) (34) of the receiver vehicles. Assumption 3 is reasonable and has been referred by several other works, e.g., in (33; 35). Assumptions 4 and 5 are widely-used in the context of enhancing V2V communication in VANETs, e.g., in (16).

Algorithm 1: JV selection process

```

1 // E: The ID of the vehicle that executes the algorithm
2 // CR: The ID of the Current Road in which E is roaming in
3 // stateJV: denotes the current state of E with type pair
  < Boolean, string >
4 flag ← True
5 J ← The ID of the closest Junction associated with CR
6 foreach Neighbor N do
7   if N belongs to one road associated with J then
8     if N closer to J than E then
9       flag ← False
10      break
11    end
12  end
13 end
14 if flag = True then
15   // The vehicle becomes a Junction vehicle associated with J
16   stateJV ← (True, J)
17 else
18   stateJV ← (False, εε)
19 end

```

3.2. System model and performance requirements

In this work, we mainly focus on the dissemination of vehicular information through V2V communication in the urban scenario. The considered scenario includes mobile vehicles randomly distributed within tow-way road segments and radio obstacles randomly distributed outside the road segments. We assume that the position retrieved from GPS is sufficiently accurate, and each road-segment has a unique ID that can be retrieved by mapping the vehicle's position in the static digital map. Assuming that every vehicle is equipped with a DSRC device, it can establish direct communication with other vehicles within its communication range. To ensure that each vehicle has up-to-date information about its neighborhood, CAMs (9) are assumed to be exchanged periodically. The radio obstacles on the road-sides can be represented by buildings or any other roadside objects.

Vehicles in VANETs are equipped with different sensors, including radars, lidars and cameras. Some of the data collected by these sensors are recognized as public-interest data, which should be disseminated among interested vehicles to achieve various purposes, such as improving road safety, optimizing traffic flow, and providing real-time traffic information to drivers. Vehicles capturing warning road-event (e.g., accident, traffic jams, roadworks, weather conditions, etc.) generate a warning message, define the AoI and trigger the dissemination process. The generated warning message is standardized by the ETSI, known in the literature as Decentralized Environmental Notification Message (DENM) (36). The message generation rules and the definition of the AoI are outside the scope of this study. Rather, we are interested in the rapid delivery of such messages to all vehicles located inside the AoI. In this regard, a data dissemination protocol in VANETs should meet several performance requirements that typically include:

1) *low latency*: Latency is usually defined as the time taken for a message to be transmitted from the sender to the receiver. In the dissemination context, low latency is critical

for safety-critical applications, such as collision avoidance, where delays can lead to traffic congestion and even accidents.

2) *High information coverage*: The disseminated data should cover all interested vehicles, meaning that the data should be successfully delivered to all vehicles within the AoI. Information coverage is particularly important for safety-critical applications, where missed or delayed messages can easily lead to accidents.

3) *Efficient use of bandwidth*: As VANETs operate in a limited spectrum, minimizing the use of the shared bandwidth is highly required to avoid collisions and improve the overall network efficiency.

4) *Scalability*: As VANETs are a time-varying networks, the designed dissemination protocol should be able to effectively scale up to accommodate a growing number of vehicles without causing a substantial decline in the dissemination performance.

3.3. Node state

In the following, we refer to the vehicle that falls closest to a given junction compared to all its neighbors as a Junction Vehicle (JV). A JV incorporates its state and the associated junction identifier inside its CAM messages, notifying its one-hop neighbors about its present state. When receiving a CAM from a JV, each receiver roaming inside one of the roads overlapped in the associated junction considers the sender JV belongs to the same road as it. The goal is to make each JV simultaneously belong to all overlapped roads. The pseudo-code given in Algorithm 1 details the JV selection process.

3.4. Relays distribution model

As described earlier, the key to ensure an efficient message coverage capability is to find how to distribute the relay nodes intelligently inside the AoI. Considering assumption 3, i.e., vehicle's transmission range is larger than the width of road, each road can be considered as a one-dimensional plane (33). Thus, it is sufficient that a set of potential vehicles distributed parallel to the road line broadcast the message to ensure the coverage of the entire road area, suggesting that the most adaptive relay distribution is parallel to the road line. Besides to the coverage enhancement, the main benefits behind the latter suggestion are two-folds. The former corresponds to the simplicity of realizing this envisioned relay distribution in a distributed manner by enabling a synergy between vehicles to form an on-the-fly backbone network along with the road line. Hence, dispensing the extra overheads incurred by the network structure forming and maintaining phases. The latter corresponds to reducing the signal blocking from the physical obstacles in the road sides e.g., the buildings, advertising boards, vegetation, traffic lights and so on, since the sent messages will be forwarded parallel to the road line. Hence, reducing the channel fading operation and enhancing the relay selection robustness by providing an obstacle avoidance forwarding strategy.

3.5. Message propagation pattern

In this paper, in order to avoid the chaotic distribution of relays and improve the message coverage capability, we

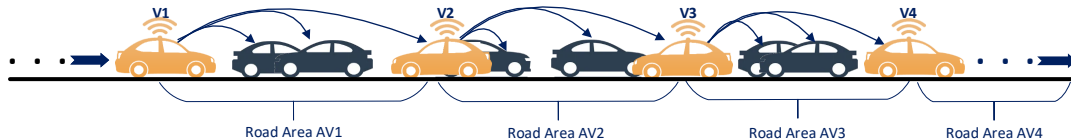

Figure 2: Proposed message propagation pattern over one-dimensional road line

aim to propagate the sent messages based on a specific pattern, further used as the guidance of the relays selection and inhibition rules. Notice that the goal is to achieve the investigated relays distribution model in a distributed manner while considering the characteristics of VANETs. In the beginning, we assume that vehicles are randomly distributed inside the AoI and a sender node (e.g., vehicle, RSU) triggers the dissemination process by broadcasting an emergency message. How the receivers deal with the sent message depends on their present states, based on which the following two cases are discussed.

1) *The receiver is not a Junction Vehicle (JV)*: In this case, the receiver follows the in-road propagation of messages, which is designed to disseminate messages under one road segment, i.e., between vehicles roaming inside the same road. As each road can be handled as a one-dimensional plane, hence the propagation of messages could be at most in two different road line directions. To do this, our proposed in-road propagation pattern enables messages to be forwarded from the rear side of the current hop relay towards its front side by means of a front neighbor, and from the front side of that relay towards its rear side by means of a rear neighbor. To illustrate the envisioned message propagation pattern, an example is shown in Fig. 2, where we assume that vehicle V1 is the current hop relay and has received the message from a rear neighbor roaming inside the same road as it. Based on the above discussion, V1 should forward the received message towards its front side by means of a potential front neighbor (vehicle V2 in this example). Notice that, considering assumption 3, the broadcast performed by V1 will cover the entire road area AV1, where the dimensions of AV1 are proportional to the sender's transmission range for length and the road width for width. Receiving the message, V2 will find that the previous relay V1 falls in its front side, hence it will forward the message towards its rear side by means of V3. The same process is repeated until reaching the last vehicle in that road, basically a JV. In this way, we ensure the coverage of the entire road progressively area by area with few number of relays and less signal blocking.

An Elector vehicle E judges whether a Neighbor N falls in its front or rear side based on the angle formed between its velocity vector, denoted as \overline{V}_E , and the line vector \overline{EN} that connects vehicles E and N (represented by Θ in Fig. 3). N is considered as a front neighbor if $\Theta_{E,N} \in [0, 90]$, and rear neighbor if $\Theta_{E,N} \in [90, 180]$. As vehicles move in two-dimensional plane (X - Y plane), we can write \overline{V}_E and \overline{EN} in

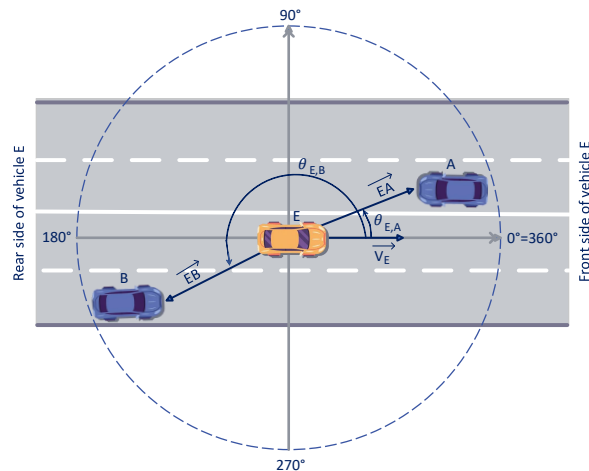

Figure 3: Front and rear neighbors determination

their corresponding components as given bellow,

$$\overline{V}_E = V_{E_x} \hat{i} + V_{E_y} \hat{j} \quad (1)$$

$$\overline{EN} = (x_N - x_E) \hat{i} + (y_N - y_E) \hat{j} = EN_x \hat{i} + EN_y \hat{j} \quad (2)$$

Where (x_N, y_N) and (x_E, y_E) are the geographical coordinates of vehicles N and E respectively. Mathematically $\Theta_{E,N}$ can be calculated by Equation 3 as given below,

$$\Theta_{E,N} = \cos^{-1} \left(\frac{V_{E_x} EN_x + V_{E_y} EN_y}{\sqrt{V_{E_x}^2 + V_{E_y}^2} \sqrt{EN_x^2 + EN_y^2}} \right) \quad (3)$$

2) *The receiver is a Junction Vehicle (JV)*: Actually, the in-road propagation of messages enables a synergy between the relay nodes to build an on-the-fly backbone network parallel to one road line. In order to merge the overlapped in-road backbones and make messages able to spread over the entire AoI, an inter-roads propagation of messages should be performed by splitting the message into multiple copies and comprehensively switching them towards the uncovered roads. In this work, we refer to the JVs as the most potential vehicles to perform the latter task for two main reasons: their ability to be simultaneously belong to all overlapped in-road backbones, and particularly their potentiality to perform the

inter-roads propagation of messages without intersecting the physical obstacles in the road sides. This is because the JVs are the most likely to be within the intersection zones, i.e., the zones with less radio obstacles.

3.6. Forwarding algorithm

In contrast to most of the existing dissemination schemes that were designed to operate exclusively based on either a sender-oriented or receiver-oriented relay selection mechanism, we rather aim to take advantages of both investigated mechanisms by combining them in one hybrid scheme. When one vehicle receives the message, it first needs to judge whether or not the message propagation pattern has been fulfilled under its coverage area by comparing the different angles of arrival of the sent message. If yes, meaning that the message has been successfully propagated under its vicinity and the vehicle is a noncritical relay candidate, it will discard the received message. Otherwise, it determines its relevance for relaying the message by computing a back-off timer associated with the following priority assignment metrics. First, we assign the shortest back-off timers to the explicitly selected relays, hence enabling a continuous retransmissions at the application layer to ensure a short latency. To do this, each vehicle behaving as a relay node should incorporate its own associated relay list inside the message before broadcasting it. On the other hand, in order to avoid the explicit relay selection shortcomings, especially the poor reachability incurred by the unexpected link failure problem, we adopt one new recovery strategy inherited from the receiver-oriented mechanism. Each receiver that has not been explicitly selected to relay the message and falls in its propagation direction should monitor the propagation of the sent message. If a recovery timer is expired and the message propagation pattern was not fulfilled under the receiver's vicinity, which means that a link failure has been occurred, the receiver will compensate for this issue by relaying immediately the message. In other words, the proposed forwarding algorithm provides a tight coupling between both existing relay selection mechanisms by enabling vehicles to collaboratively handle the multi-hops retransmissions of messages in an efficient manner. Hence, besides to the coverage enhancement, messages could be forwarded rapidly with few overheads and high reachability rate.

4. Proposed BACKNET-HSR data dissemination scheme

In this section, we will first provide an overview of the key components of BACKNET-HSR and subsequently delve into each component with further elaboration.

4.1. BACKNET-HSR overview

The flowchart depicted in Fig. 4 presents the whole dissemination process of our scheme, which includes the following key parts:

1) *Inhibition rule*: It includes the different rules that determine whether a vehicle becomes a relay node or not.

2) *Explicit selection of relays*: It encompasses the timer settings and the relay selection algorithm of our proposed sender-oriented relay selection mechanism.

3) *Implicit selection of relays*: It includes the different timer settings of our proposed receiver-oriented relay selection mechanism.

4.2. Inhibition rule

As mentioned earlier, consider a flat network structure, the lack of an efficient message propagation pattern leads to an indiscriminate inhibition of the relay candidates, resulting in a poor message coverage capability. To deal with this problem, each vehicle should make its own decision on relaying the data in a distributed manner based on its potentiality for realizing the envisioned message propagation pattern under its coverage area. To do this, each vehicle monitors the propagation of the sent message under its coverage area and infers whether or not the envisioned propagation pattern has been fulfilled in that area. By assuming that a given vehicle heard the transmissions of the same message from two neighbors falling in the two different road line sides (i.e., front and rear neighbors), hence it can be deduced that the vehicle should not be considered as a potential relay candidate, since the expected in-road backbone has been already built inside its monitoring area. Otherwise, if the vehicle has received the message from neighbor(s) falling in one road line side, meaning that a disconnection of the envisioned in-road backbone has been occurred, the vehicle becomes a critical relay candidate due to its high potential for fixing the disconnection issue by relaying the message towards the uncovered road side. As a result, as shown in Fig. 4 (left dotted rectangle), the only case in which a vehicle becomes inhibited to relay the message is the fulfillment of the message propagation pattern under the vehicle's vicinity, which is achieved when hearing the transmission of the same message from at least two neighbors falling in two different road line sides.

4.3. Explicit selection of relays

In order to handle the delay sensitive VANET-based applications, the sender-oriented relay selection mechanism has been exhibited as a promising solution to spread data rapidly over multiple depots. By adopting the explicit selection of relays, a continuous retransmission at the application layer can be realized. The sender nodes should incorporate the identifiers of the next dissemination entities inside the disseminated data, which will be able to rebroadcast immediately. Because of the unique characteristics of VANETs, ensuring a good network reachability represents the major challenge of the explicit selection of relays. Thus, taking into account the robustness of the forwarding links during the process of relays selection is quite important for enhancing the data delivery capability. Next, we will introduce our proposed relay selection metrics for improving reachability, then we will detail the explicit relays selection algorithm.

4.3.1. Relay selection metrics

As discussed in (37), the mobility metrics show better performance results in the context of a good network reachability in VANETs. For this reason, we aim to provide sufficient connection duration between neighboring relays by considering the mobility of vehicles. Thus, improving the

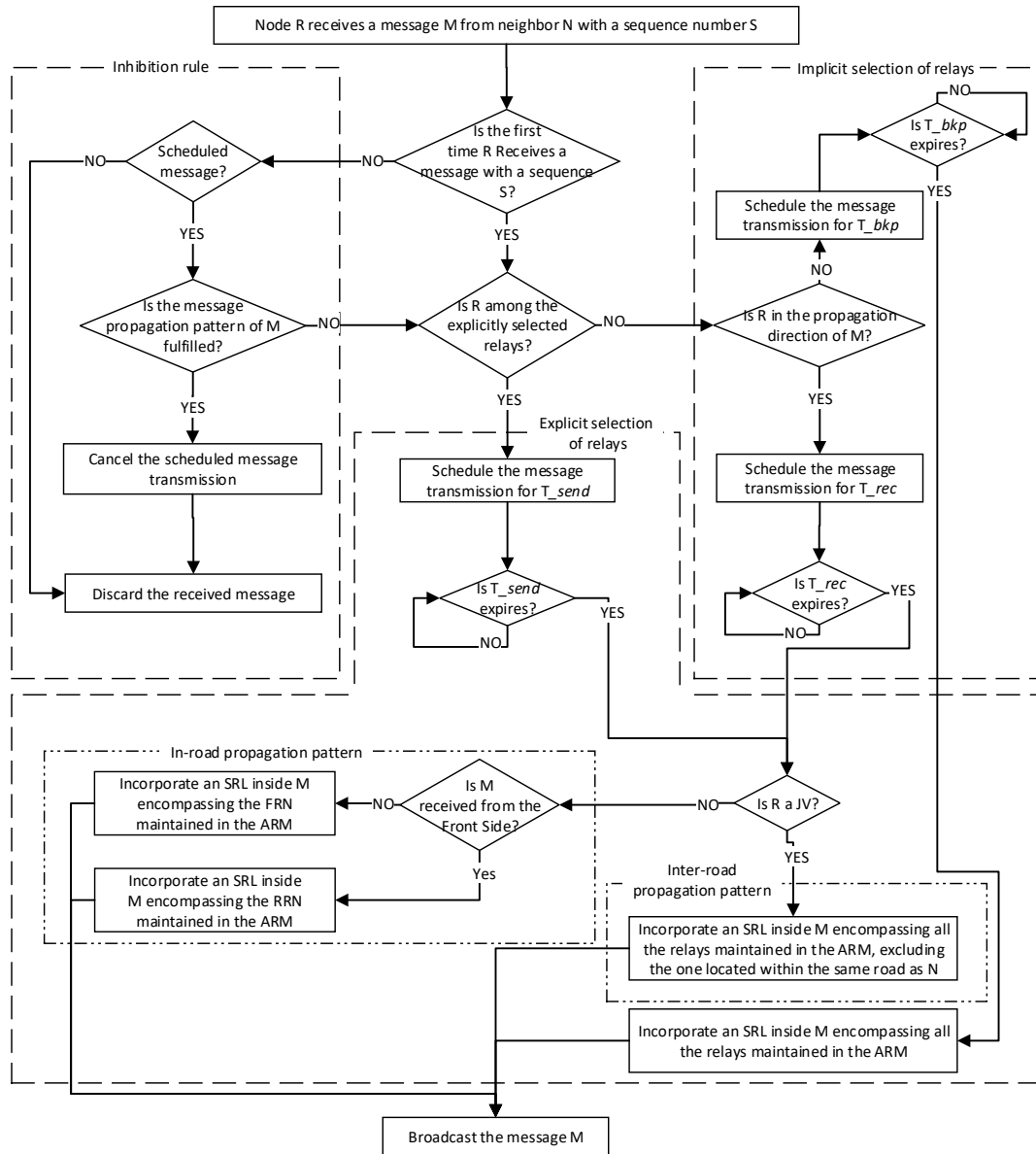

Figure 4: The flowchart of the proposed Dissemination scheme

stability of the wireless link connections and mitigating the rapid link failure problem. On the other hand, as roads are not always straight, we aim to fit the strip-shaped roads by taken into account the curvature of the road lines when selecting the next hop relays. The goal is to realize our envisioned obstacle avoidance forwarding strategy in different road line geometries without exploiting the received radio strength (RSS) metric that were considered as unsuitable in VANETs due to its poor precision (37; 38). Additional solutions for improving reachability could be included in our relay selection metrics, but remind that we focus on the recovery strategy to achieve this goal, as described in Subsection 4.4. The proposed relay selection metrics are described as follow:

1) *Distance factor:* In order to achieve the desired coverage with few number of relays, we exploit the greedy forwarding algorithm to assign priority to the neighbors further away from the elector for becoming relay nodes. However, considering the high mobility constraints, the greedy mode easily lead to an unexpected link failure problem (39; 40) since the farthest away (i.e., the ones that fall closer to the communication radius of the elector vehicle) are the most likely to be moved outside the elector's communication radius, resulting in a poor reachability between neighboring relays. To cope with this problem, we tend to adjust the greedy algorithm with the mobility of vehicles for ensuring stable communication links. To achieve this goal, we assign

priority to the neighbor falling furthest in distance and remaining within the transmission range of the elector vehicle for a given period of time, measured as the time interval between two successive beacon messages (referred to as Δt). Thus, the distance factor $\overline{d_{E,N}}$ between an elector E and its neighbor N can be computed as:

$$\overline{d_{E,N}} = 1 - \frac{\left| \sqrt{(x_E - x_N)^2 + (y_E - y_N)^2} - d_{opt} \right|}{d_{opt}}, \quad (4)$$

where (x_N, y_N) and (x_E, y_E) denote the geographical coordinates of vehicles N and E respectively, and d_{opt} stands for the optimal distance between two neighboring relays which can be evaluated as:

$$d_{opt} = d_{max} - 2v_{max}\Delta t,$$

where d_{max} denotes the maximum transmission range of the adopted DSRC device, and v_{max} represents the allowed maximum speed of vehicles.

2) *link straightness factor*: The goal behind this evaluation factor is to comprehensively adjust the relays distribution according to the road line curvature, thus maximizing the dissemination coverage capability over one road-segment, as well as ensuring our envisioned obstacle avoidance forwarding strategy even in case of strip-shaped roads. To do this, we first exploit the mobility direction of the elector vehicle as an indicator of the road curvature. To be noted that the movement trajectory of vehicles is basically parallel to the road line. Then, we tend to assign priority to the neighbor where the angle between its location and the elector's velocity vector, i.e., the angle Θ described in Equation 3, approaches to 0 (*zero-angle*) or 360 (*complete-angle*) for becoming an associated Frontal Relay Node (FRN). On the other side, the neighbor that forms a straight angle (i.e., approach to 180) is more likely to play the role of associated Rear Relay Node (RRN). For the purpose of the link straightness factor evaluation, the elector assigns priorities to the neighbors with the optimal angle $\overline{\Theta_{E,N}}$. How to compute $\overline{\Theta_{E,N}}$ depends on the state of the associated relay candidate, i.e., FRN or RRN candidate, as given below,

$$\overline{\Theta_{E,N}} = \begin{cases} 1 - \frac{\Theta_{E,N}}{90} & , \Theta_{E,N} \in [0, 90] \\ \frac{\Theta_{E,N}}{180} & , \Theta_{E,N} \in]90, 180] \end{cases} \quad (5)$$

Where $\Theta_{E,N}$ stands for the angle Θ described in Equation 3.

4.3.2. Relay selection algorithm

Conventional sender-oriented relay selection mechanism requires the incorporation of the explicitly selected relay(s) within the transmitted message. Compared to the receiver-oriented relay selection mechanism, this will slightly increase the size of the transmitted packet. Meanwhile, it significantly reduces the latency. In this work, the explicit

Algorithm 2: Associated relays selection process: the vehicle is not a JV

```

1 // E: The ID of the vehicle that execute the algorithm
2 // CR: The ID of the road in which E is roaming in
3 if stateJV.first = True then
4   goto Algorithm 3
5   return
6 end
7  $\omega_{FRN}^{max}, \omega_{RRN}^{max} \leftarrow 0$ 
8 Map < string, address > MAP  $\leftarrow null$ 
9 foreach Neighbor N do
10  if N falls in CR then
11     $\Theta_{E,N} \leftarrow$  Compute the angle  $\Theta$  as given in Equation 3
12     $\omega_{f_{E,N}} \leftarrow$  Compute  $\omega_{f_{E,N}}$  as given in Equation 6
13    if  $\Theta_{E,N} \in [0, 90]$  then
14      // N will be handled as an FRN candidate
15      if  $\omega_{f_{E,N}} > \omega_{FRN}^{max}$  then
16         $\omega_{FRN}^{max} \leftarrow \omega_{f_{E,N}}$ 
17        MAP  $\leftarrow insert('FRN', N.address)$ 
18      end
19    else
20      // N will be handled as an RRN candidate
21      if  $\omega_{f_{E,N}} > \omega_{RRN}^{max}$  then
22         $\omega_{RRN}^{max} \leftarrow \omega_{f_{E,N}}$ 
23        MAP  $\leftarrow insert('RRN', N.address)$ 
24      end
25    end
26  end
27 end
28 ARM  $\leftarrow$  MAP

```

selection of relays could be performed in a proactive manner due to the advance knowledge of the message propagation pattern. This helps in avoiding the computation overload during the dissemination process. To do this, each vehicle build its own Associated Relays MAP (ARM) based on the information gathered from the received CAM messages. How to elect the associated relays and how to behave during the dissemination process depend on the status of the vehicle, where the following two cases are distinguished:

1) *The vehicle is not a JV*: In this case, the goal is to construct an on-the-fly in-road backbone parallel to the road line. Therefore, the relay selection rule is designed to fit the concept of the in-road propagation pattern, as outlined in Algorithm 2. The vehicle selects, from the neighbors roaming inside the same road, the most valuable neighbor located in its front side as an associated Frontal Relay Node (FRN), and the most valuable neighbor located in its rear side as an associated Rear Relay Node (RRN). The ARM in this scenario is represented by a MAP composed of the type of the selected relay (FRN/RRN) and its associated address. Upon behaving as a relay node, the vehicle incorporates the address of the corresponding associated relay inside the message and broadcast. Specifically it incorporates the associated FRN's address if the message has been received from the rear side; otherwise, the associated RRN's address.

2) *The vehicle is a JV*: In this case, the objective is to interconnect all the in-road backbones overlap in the respective junction. Therefore, the relay selection rule is designed to fit the concept of the inter-road propagation

Algorithm 3: Associated relays selection process: the vehicle is a JV

```

1 // E: The ID of the vehicle that execute the algorithm
2 // J: The Junction ID that the junction vehicle E associated with
3 Map < string, address > MAP ← null
4 foreach Road  $R_i$ , associated with J do
5    $\omega_{E,N}^{max} \leftarrow 0$ 
6   foreach Neighbor N roaming in  $R_i$  do
7      $\omega_{E,N} \leftarrow$  Compute  $\omega_{E,N}$  as given in Equation 6
8     if  $\omega_{E,N} > \omega_{E,N}^{max}$  then
9        $\omega_{E,N}^{max} \leftarrow \omega_{E,N}$ 
10      MAP ← insert( $R_i.ID, N.address$ )
11    end
12  end
13 end
14 ARM ← MAP

```

pattern, as outlined in Algorithm 3. For each group of neighbors roaming within each overlapped road, the JV selects the most appropriate neighbor as an associated relay, i.e., one valuable neighbor for each overlapped road. The ARM in this scenario is represented by a MAP composed of the overlapped road identifier and the address of its respective relay. Upon behaving as a relay node, the JV incorporates the addresses of all its associated relays, except the one that is roaming within the road from which the message has been received.

An elector vehicle E determines the capacity of each associated relay candidate N based on the above relay selection metrics, as given bellow:

$$\omega_{E,N} = \begin{cases} \alpha \overline{d_{E,N}} + (1 - \alpha) \overline{\Theta_{E,N}} & , \text{if } E \text{ is not a JV} \\ \overline{d_{E,N}} & , \text{Otherwise} \end{cases}, \quad (6)$$

where α represents a weight parameter such that $\alpha \in [0, 1]$. In this work, we tend to dominate the distance influence factor by setting α to 0.8, as the most adaptive value in our simulation study.

At this stage, it should be noted that the message may include more than one explicitly selected relay, especially in cases where the vehicle is a JV or when the vehicle itself is the message originator (incorporating all the associated relays maintained within the ARM into the message). Consequently, these relays will be incorporated as a list denoted as explicitly Selected Relay List (SRL). However, it is crucial to recognize that selecting multiple neighbors to relay the message can lead to the simultaneous retransmissions and hidden nodes issues. To solve these issues, we adopt an index-based timer that enables the explicitly selected relays to schedule their transmissions for a T_{send} timer, computed based on the relay's index in the received ARM. The one with index zero rebroadcasts immediately, the second rebroadcasts after λt delay, and so on. T_{send} is calculated as given below,

$$T_{send} = i_j \lambda t, \quad (7)$$

where i_j denotes the index of the explicitly selected neighbor N_j in the ARL, and λt represents one waiting time slot.

4.4. Implicit selection of relays

Considering the unique characteristics of VANETs, it is complex to guarantee robust wireless link between mobile vehicles. In other words, important packet loss still occurred because of the unexpected link failure problem, even-though taken into account multiple link condition parameters. Thus, adopting one new recovery strategy for compensating the lost packets while not increasing the dissemination delay is quite important to enhance the dissemination efficiency. To achieve this goal, we first adjust our proposed inhibition rule with the message propagation pattern perspectives by making all vehicles able to monitor the propagation of the sent message under their transmission ranges. Then, each vehicle could make its own decision on relaying the message in a distributed manner, independently on whether or not they are explicitly selected to relay the data. One simple and efficient solution to implement this is to let every vehicle receiving the sent message and fall in its propagation direction to hold it and schedule its transmission for a recovery timer T_{rec} . If T_{rec} expires and no inhibition occurred, i.e., a link failure is captured, the vehicle recovers quickly this issue by broadcasting the message immediately. A vehicle considers itself as falling in the message propagation direction if it is not inhibited to broadcast and has received the message from neighbor roaming inside the same road as it. T_{rec} is computed as given bellow:

$$T_{rec} = T_{rec}^{max} \left[\alpha \left(1 - \frac{d_{R,P}}{d_{max}} \right) + (1 - \alpha)(1 - \overline{\Theta_{R,P}}) \right], \quad (8)$$

where T_{rec}^{max} denotes the maximum recovery timer value; $d_{R,P}$ represents the distance between the Receiver R and the Previous relay node P, computed as:

$$d_{R,P} = \sqrt{(x_P - x_R)^2 + (y_P - y_R)^2},$$

where (x_N, y_N) and (x_P, y_P) denote the geographical coordinates of vehicles N and P respectively; and $\overline{\Theta_{R,P}}$ stands for link straightness factor, computed as given by Equation 5. Unlike Equation 6, JV and non-JV are not distinguished in this equation since a JV is considered to belong to each of the roads that overlap in the relevant junction. Hence, similarly to any other non-JV, it schedules its transmission for T_{rec} as soon as it hears a message transmission from one of the road it belongs to. This ensure that the in-road propagation of messages will always end-up in a JV, which, in turn, forwards the messages towards the other overlapping roads.

In order to ensure robust relay selection process, remark that both implicit and explicit relay selection metrics are compliant with each other, except of the mobility parameters since the implicit selection has no requirement with the stability of the link connection. Meanwhile, we consider the link straightness factor to enhance the connectivity between the explicitly selected relay and the monitoring vehicles. This helps mitigate the issue of unnecessary retransmissions,

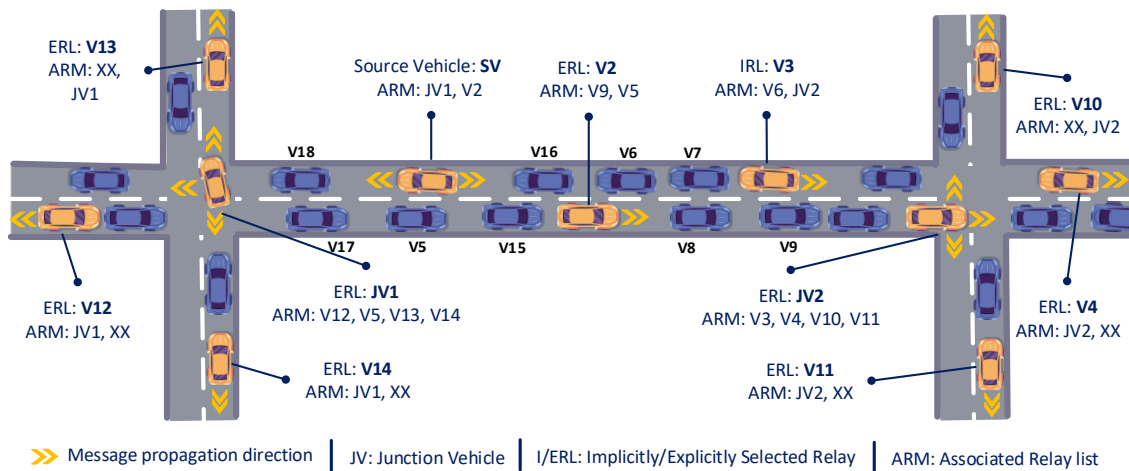

Figure 5: Example of the proposed dissemination scheme

a common problem in receiver-oriented solutions occurs in the case where a vehicle does not cancel its scheduled transmission due to the lack of reception of the other retransmissions.

It is important to highlight that Equation 8 does not account for the scenario where T_{rec} expires while T_{send} is still counting down. The reason behind this is to speed up the recovery process, taking into account that the performance of our proposed relay selection algorithm will not be compromised since this situation can arise only in a particular scenario where there exists a more valuable or at least relatively equivalent relay candidate compared to the explicitly selected relay.

Besides, as VANETs have a time-varying density, we introduce an additional timer, namely Backup or T_{bkp} , for fitting the sparse network scenario where the density of vehicles is not enough to ensure the envisioned propagation of messages. In this way, vehicles that receive for the first time the sent message and do not fall in its propagation direction will schedule their transmission for a backup timer, which is computed as given below:

$$T_{bkp} = T_{bkp}^{max} + \mu(0, 0.1), \quad (9)$$

where T_{bkp}^{max} denotes the maximum backup timer value, and $\mu(0, 0.1)$ represents an uniformly distributed random component to avoid the simultaneous retransmissions problem. If the vehicle is not inhibited after elapsing T_{bkp} time, meaning that a network partition is captured, the vehicle should immediately relay the message inside the road that is belonging to. Hence, it fills the SRL with all its associated relays within the ARM and broadcasts the message.

4.5. A case study

To illustrate the proposed dissemination scheme, an example scenario is shown in Fig. 5, where we assume that the Source Vehicle SV starting the dissemination process. In the beginning, SV fills the SRL with all its associated relays, i.e.,

JV1 as FRN and V2 as RRN, and broadcasts the message. Receiving for the first time the sent message from one neighbor roaming inside the same road as them, all the receivers V2, V5, V15-V18 and JV1 are considered as falling in the message propagation direction. Thus, the explicitly selected relays JV1 and V2 should schedule their transmissions for T_{send} , while the others schedule their recovery timers T_{rec} . Having a JV status, the ARM of JV1 is formed based on the inter-road propagation of messages by selecting one vehicle for each overlapped road, i.e., vehicles V5, V12-V14. Hence, it fills the SRL with the vehicles V12-V14 and forwards the message. Upon hearing the broadcast performed by JV1, the vehicles V5, V17 and V18 should immediately cancel their scheduled transmission, since the message propagation pattern has been already fulfilled in their transmission range by receiving twice copies of the same message from neighbors falling in two different road line directions (SV and JV1). As JV1 simultaneously belongs to all the overlapped roads, the explicitly selected relays V12-V14 broadcast after T_{send} , while the other receivers schedule T_{rec} . For example, V13 finds that the message was received from a rear neighbor, hence it should forward it towards its front side. Similarly, V2 forwards the message towards its front side by means of its FRN V9. However, in order to activate the implicit selection of relays, we assume that V9 has been moved outside the communication radius of V2, hence, it does not hear the transmission made by V2. Following the investigated implicit relays selection algorithm, vehicles V3 and V6-V8 are falling in the propagation direction of the message forwarded by V2, hence they schedule their transmission for T_{rec} . Consider that V3 has the shortest T_{rec} and V9 does not broadcast, V3 will be an implicitly selected relay. Notice, that the broadcast made by V3 will make the monitored message propagation pattern of vehicles V6-V8 fulfilled, which will force them to cancel their scheduled transmissions. The same process is repeated until ensuring the coverage of the entire AoI.

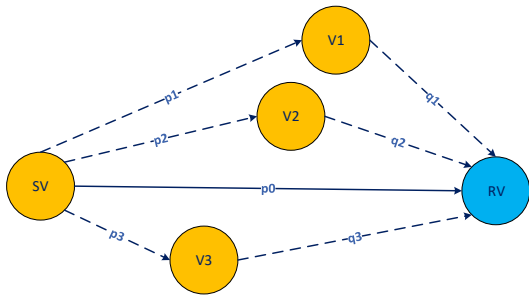

Figure 6: Reachability improvement in the proposed BACKNET-HSR scheme

4.6. Theoretical analysis of BACKNET-HSR

This subsection presents a probabilistic analysis of the benefits achieved through the integration of sender-oriented and receiver-oriented relay selection mechanisms within the hybrid BACKNET-HSR scheme. The goal is to capitalize on the strengths of both mechanisms, simultaneously leveraging the low latency of the sender-oriented mechanism and the high reachability of the receiver-oriented mechanism, while mitigating the trade-offs between them. As depicted in Fig. 6, when exclusively employing the sender-oriented mechanism, the explicitly selected relay RV has only one chance, with a probability of p_0 , to receive the message from SV. However, our proposed monitoring process transforms all vehicles V1-V3 into alternative relays. This means that if RV fails to receive the message from SV, one vehicle among V1-V3 will implicitly be selected to relay the message. For the sake of simplicity, let us consider only one alternative relay, saying V1. Therefore, the probability of RV receiving the message sent by SV is calculated as follows:

$$\bar{p} = p_0 + (1 - p_0)p_1q_1 \quad (10)$$

By increasing the number of alternative relays, the reception probability \bar{p} will be improved linearly. For n alternative relays, \bar{p} can be expressed as follows:

$$\begin{aligned} \bar{p} = & p_0 + [(1 - p_0)p_1q_1] + [(1 - p_0)(1 - p_1q_1)p_2q_2] + \dots + \\ & [p_nq_n(1 - p_0) \prod_{i=1}^{n-1} (1 - p_iq_i)] \end{aligned} \quad (11)$$

Without loss of generality, we can assume a uniform reception probability denoted as p for each pair of neighboring vehicles. In other words, we assume that $p_0, p_1, \dots, p_n = q_0, q_1, \dots, q_n = p$. Consequently, we can use the complement rule to simplify \bar{p} as shown below:

$$\bar{p} = 1 - [(1 - p)(1 - p^2)^n] \quad (12)$$

As data dissemination in VANETs relies on a multi-hop retransmission paradigm, the reception probability for a vehicle at a distance of m -hops away from the sender can be expressed as follows:

$$\bar{p}_m = \bar{p}^m = [1 - [(1 - p)(1 - p^2)^n]]^m \quad (13)$$

Notice that for the sender-oriented baseline mechanism, the reception probability is $\bar{p} = p$, and thus, $\bar{p}^m = p^m$. Fig. 7 illustrates the average reception probability for two scenarios: Fig. 7(a) Single hop transmission \bar{p} , and Fig. 7(b) Multiple hops retransmission \bar{p}^m . Both figures demonstrate that our proposed combination of sender-oriented and receiver-oriented relay selection mechanisms results in a significant improvement in terms of reachability.

In addition to achieve reachability improvement, our objective also includes avoiding the trade-offs between both mechanisms to ensure low latency. It is essential to acknowledge that latency poses a distinctive challenge in receiver-oriented approaches, primarily stemming from the intermittent retransmissions caused by the adoption of back-off timers at the application layer. In the context of BACKNET-HSR, the receiver-oriented mechanism serves as a recovery strategy for the sender-oriented mechanism, offering alternative relays in case of link disconnection. Consequently, any additional delay would only be incurred when a link disconnection is captured. As a result, the overall dissemination latency is not significantly impacted under normal conditions.

To substantiate the above assertion, we will denote t_s as the average processing and queuing time taken by a relay node for relaying the data. Additionally, let's denote t_b as the average back-off timer of the adopted receiver-oriented mechanism. Regarding a receiver vehicle located at a distance of m -hops > 0 away from the sender, the average latency \bar{t} can be expressed as $t_s \times m$ for the sender-oriented mechanism, and $t_s + (t_s + t_b) \times (m - 1)$ for the receiver-oriented mechanisms. Considering the uniform reception probability p of the explicitly selected relays, \bar{t} in BACKNET-HSR can be expressed as follows:

$$\bar{t} = t_s + \sum_{i=1}^{m-1} t_s p + t_b(1 - p) = t_s + (m - 1)[t_s p + t_b(1 - p)] \quad (14)$$

Fig. 8 presents a comparison of the average latency among three mechanisms: sender-oriented, receiver-oriented, and BACKNET-HSR (hybrid). As shown in this figure, the latency between BACKNET-HSR and the baseline sender-oriented mechanism becomes more similar as the reception probability p increases. This behavior arises due to the fact that a higher value of p indicates a lower likelihood of link disconnections, hence a greater utilization of the sender-oriented mechanism in favor of the recovery strategy (receiver-oriented mechanism). Conversely, when the

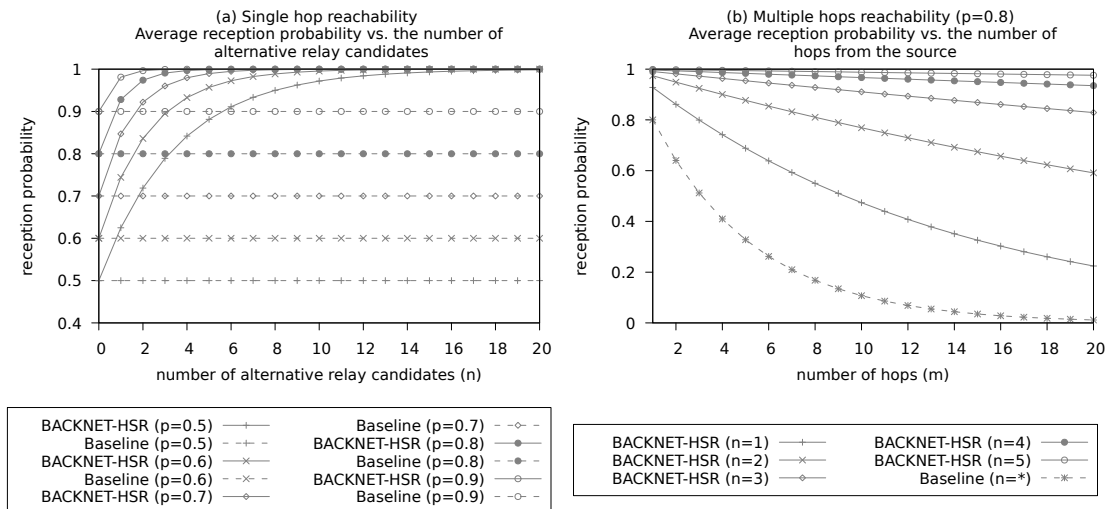

Figure 7: Reachability ratios in Single-Hop and Multiple-Hop scenarios: A comparative analysis of Baseline sender-oriented mechanism vs. BACKNET-HSR

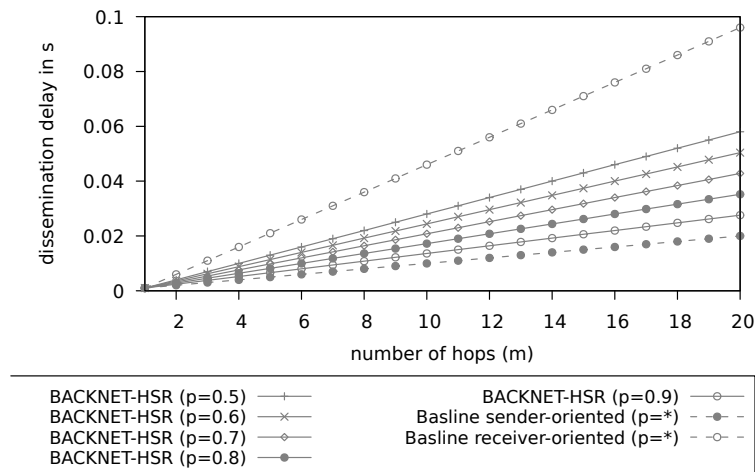

Figure 8: Dissemination delay ratios: A comparative analysis of Baseline sender-oriented, Baseline receiver-oriented, and BACKNET-HSR mechanisms ($t_s = 1\text{ms}$, $t_b = 5\text{ms}$)

reception probability p decreases, the recovery strategy becomes used more, then the latency between BACKNET-HSR and the baseline receiver-oriented mechanism becomes more similar. In this context, it should be noted that, in general, the value of p is sufficiently high to ensure acceptable reachability in sender-oriented approaches. This, in turn, contributes to the effectiveness of BACKNET-HSR as it leverages the sender-oriented mechanism for its rapid propagation of messages, balancing both receiver-oriented reachability and sender-oriented latency to enhance the overall performance of the network.

5. Performance evaluation

This section provides a comprehensive evaluation of our proposed BACKNET-HSR conducted on OMNET++

(version 5.6.2) (41) and compared with two baseline approaches, i.e., Contention based Forwarding (CBF), and Bi-Directional Stable Communication (BDSC). CBF has been chosen for this evaluation because it serves as the current GeoNetworking standard of data dissemination in VANETs (9). It operates based on three parameters that are set as outlined by the ETSI in (9). These parameters are: minimum timer value=1 ms, maximum timer value=100 ms, and maximum distance=250 meters, which represents the maximum communication range of the wireless access technology adopted in this simulation. Given that CBF adopts a receiver oriented relays selection mechanism, we have chosen BDSC because it relies on a sender-oriented relays selection mechanism and has been specifically proposed to address the same problem identified by BACKNET-HSR. The variant ($LQ \times d$) of BDSC with a cardinality $C=12$ has been chosen because it was presented as the most efficient

approach compared to the other convolution schemes proposed in (14).

BACKNET-HSR relies on the on-hop information gathered by the CAM messages. For this reason, a CAM exchanging algorithm is firstly implemented in accordance with the specifications outlined by the ETSI (5). The frequency at which CAMs are sent is a research topic in several studies. However, this topic is not addressed in the present work. Instead, we maintain a consistent sending frequency of CAMs, specifically one CAM per second for each vehicle, as suggested in numerous relevant works. Based on the information obtained from CAMs and SUMO road topology, each simulated vehicle determines its state as described in Algorithm 1. Then, it selects its associated relays in accordance with its state as given in Algorithms 2 and 3. Once the vehicle receives a disseminated message, it behaves according to the instructions outlined in the flowchart depicted in Fig. 4. Table 3 includes the parameters defined for BACKNET-HSR in the experiments. The parameter d_{max} denotes the maximum distance between two neighboring vehicles, which is inherently equivalent to the maximum transmission range specified in our simulation. Similarly, we set v_{max} as the maximum speed of vehicles, as specified in our SUMO traffic simulation. The parameter α can vary depending on the number of radio obstacles and the adopted path loss model. Minimizing this parameter means assigning greater importance to the linearity of relays with respect to the distance influence factor, and vice versa is correct. As mentioned in (18), it is recommended to dominate the distance influence factor by approximately 80% to enhance the effectiveness of dissemination. Therefore, we have set the parameter α to 0.8 in Equations 6 and 8. λt , T_{rec}^{max} and T_{bkp}^{max} are utilized to ensure the ordered combination of both adopted sender-oriented and receiver-oriented relays selection mechanisms. λt and T_{rec}^{max} have similar role to the parameters minimum timer value and maximum timer value of CBF, respectively. Hence, we have set $\lambda t = 1ms$ and $T_{rec}^{max} = 100ms$ as outlined by the ETSI. T_{bkp}^{max} is defined to fit the sparse network scenarios, where the density of vehicles is not enough to ensure the envisioned propagation pattern of messages. This parameter has been chosen through experimental evaluation after conducting a series of initial simulations, revealing that the most suited value to the designed simulation scenario is 20 ms. Increasing the value of T_{bkp}^{max} leads to the expansion of latency, especially in the sparse network scenarios. Conversely, reducing its value does not align with the envisioned propagation pattern requirements.

5.1. Simulation setup

In order to compare BACKNET-HSR with CBF and BDSC in a realistic vehicular environment, we use VEINS (version 5.1) (42) on the top layer of OMNET++. VEINS is an open-source framework designed to simulate realistic models for vehicular communication and mobility. It provides the necessary protocol stacks to simulate an accurate V2V communication paradigm, including the functionalities of the physical (PHY), medium access control (MAC), and

Table 3
Main simulation parameters

Parameter	Value
Simulation time	120 s
Mac model	IEEE 802.11p
Vehicle density	30-125 vehicles/km
Radio transmission power	3 mW
Maximum transmission range	≈ 250 m
Bit rate	6 Mbit/s
Carrier frequency	5.89 GHz
Transmission power consumption	2 W
Receiving power consumption	1.3 W
Beacon size	32 Bytes
Beacon frequency	1 /s
α	0.8
λt	1 ms
d_{max}	250 m
v_{max}	14 m/s
T_{rec}^{max}	100 ms
T_{bkp}^{max}	20 ms

network layers. Note that all three assessed dissemination protocols are media independent, meaning that they can be implemented over any Device-to-Device (D2D) communication process. In this study, the MAC and PHY parameters are configured to match the specifications defined by the IEEE 802.11p vehicular communication standard, which is already implemented in VEINS. To simulate signal propagation under an obstructed urban vehicular environment, we employ the Two-Ray Interference propagation model of VEINS. This model is widely-used in vehicular communication simulations as it considers both signal attenuation and ground reflection effects to accurately estimate the received signal strength. We employ the simple energy storage model to simulate the energy consumption. This model takes into account the variation of the consumed energy across the different states of the network interface, namely idle, sleeping, transmitting, and receiving states. Similar to (43), we set the idle and sleeping power consumption to zero, as these states exhibit similarity across all vehicles. Additionally, based on the Unex DCMA-86P2 card (43), we have configured the transmission and reception power to 2W and 1.3W respectively.

To simulate the real-world traffic scenario, we use SUMO (version 1.8.0) (44) to model the movements of vehicles in a road network. SUMO is a microscopic simulation tool renowned for its accurate representation of road geometry, traffics lights, and traffic flow. By coupling VEINS with SUMO, the simulated vehicles in VEINS can emulate realistic traffic patterns and respond to the road conditions. VEINS communicates with SUMO to gather real-time data about each simulated vehicle, encompassing information about their location, speed, heading, and the road being traveled. These information are required for VEINS to perform various network operations, including the simulation of communication range, signal propagation, and interference effects. Additionally, all three dissemination protocols rely on these information to execute their respective tasks, such as distance computation and vehicle state update. The

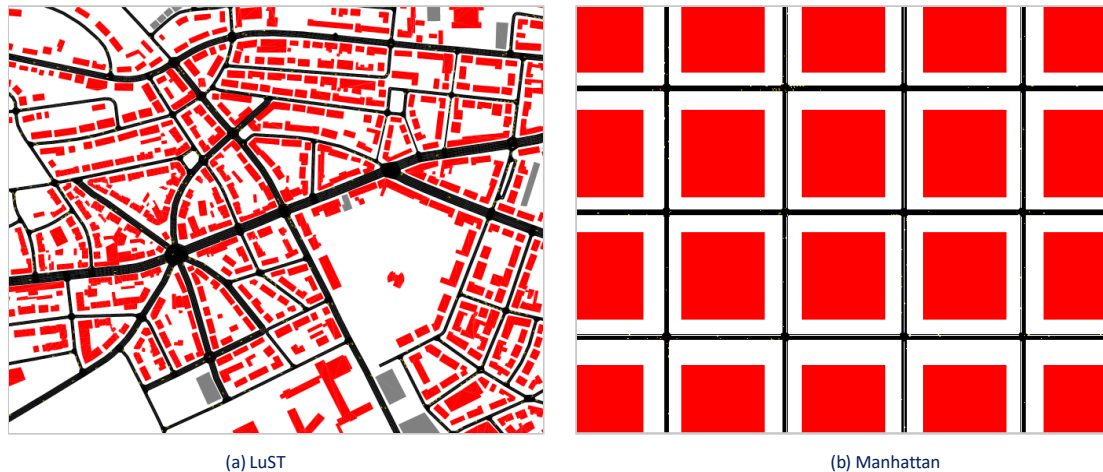

Figure 9: Simulated urban scenarios. Representative region of each scenario

information gathered by VEINS are sufficiently accurate to ensure the smooth execution of the adopted algorithms, aligning with our underlying assumptions. The main simulation parameters are summarized in Table 3.

The characteristics of road topography in VANETs have a substantial impact on the performance of the communication protocol (45). Therefore, two urban simulation scenarios are considered in this evaluation. The simplest scenario is a Manhattan grid scenario comprised of 81 evenly-spaced intersections in an area of $2,5 \text{ km} \times 2,5 \text{ km}$ square area (see Fig. 9 (a)). We generate eight horizontal and eight vertical bidirectional road segments. To represent buildings, rectangular shapes of $200 \text{ m} \times 200 \text{ m}$ are distributed along the roadside. The mobility of vehicles is generated using the car-following model, a well-established concept in traffic simulation, based on the “random-trips” model in SUMO. The second scenario is a realistic scenario known as Luxembourg SUMO Traffic (LuST) scenario (46; 47). LuST provides a realistic representation of urban traffic conditions, including intersections, traffic lights, and various road types of Luxembourg City, the capital of Luxembourg. The vehicular traffic model in LuST is based on real-world traffic data observed in Luxembourg City. In other words, a realistic mobility pattern of vehicles is utilized that take into account multiple factors such as traffic flow, congestion, and signal timings. In this simulation, we selected a $2 \text{ km} \times 2,5 \text{ km}$ square area located in the city center of Luxembourg, as depicted in Fig. 9 (b).

To model the dissemination process of Decentralized Event Notification Message (DENM) (36), source nodes are randomly selected at every simulation experiment. Typically, 10 random vehicles are chosen to act as source nodes. Each of these vehicles triggers the dissemination process by broadcasting one DENM comprised of 1024-byte data every 10 seconds. In order to assess the dissemination performance under a large scale network, we consider the whole network region as AoI. To meet the scalability requirements, six scenarios with different vehicle densities were defined for

each urban simulation scenario. These densities simulate a range of traffic scenarios, including very sparse (30 vehicles/Km square), sparse (40 vehicles/Km square), medium (50 vehicles/Km square), normal (75 and 100 vehicles/Km square), and dense (125 vehicles/Km square). A simulation experiment lasts 120 seconds, with a warm-up period of 20 seconds. For statistical confidence, each simulation experiment was repeated five times, meaning that each data point in the presented resulted represents the arithmetic mean of five repeated experiments.

5.2. Performance metrics

The efficiency of a data dissemination protocol is evaluated based on its capability to successfully deliver messages to all vehicles within the AoI while avoiding significant delays or channel overloading (48; 49). To assess the performance of all three investigated protocols, we consider these requirement by defining the following evaluation metrics:

1) *Dissemination coverage*: this evaluation metric is used to measure the percentage of vehicles that successfully receive the disseminated messages out from the total number of vehicles within the AoI. The higher the dissemination coverage percentage is, the enhanced the awareness and response among vehicles within VANETs. Giving that the number of disseminated messages is NbM_{sgs} , the number of intended vehicles that successfully receive a message (i) is $NbRec_i$, and the total number of intended vehicles at the time of sent (j) is $NbTot^j$; the average Dissemination Coverage (DC) is computed as follows:

$$DC = \frac{1}{NbM_{sgs}} \sum_{i=1}^{NbM_{sgs}} \frac{NbRec_i}{NbTot^j} \quad (15)$$

2) *Dissemination Delay*: This evaluation metric is used to measure the average elapsed time that a message takes to reach the intended vehicles. The lower the delay is, the more enhanced the response time and decision-making are for vehicles. Given that the number of disseminated message

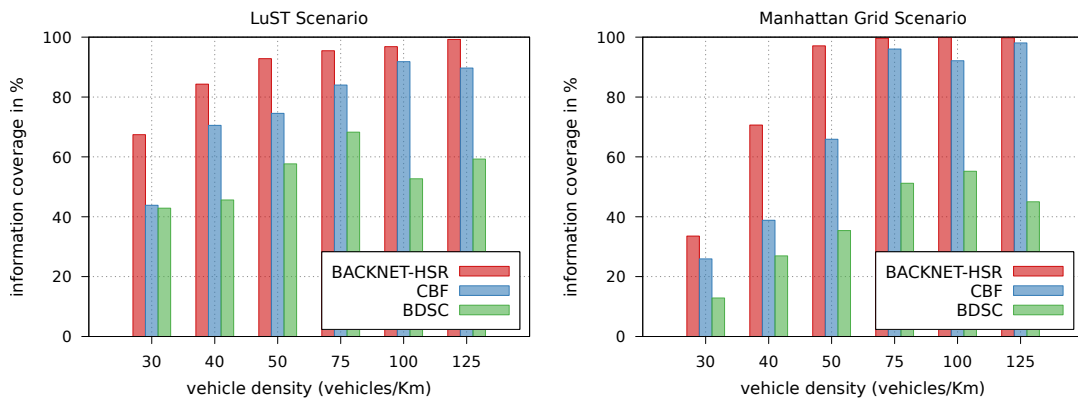

Figure 10: Information coverage ratio vs. vehicle density.

is $NbMsgs$, the time at which a source vehicle triggers a message i is $SendT^i$, the time at which an intended receiver vehicle k received the message i is $RecT_k^i$, and the number of intended vehicles that successfully receive a message i is $NbRec_i$; the average Dissemination Delay (DD) is computed as follows:

$$DD = \frac{1}{NbMsgs} \sum_{i=1}^{NbMsgs} \left[\frac{1}{NbRec_i} \sum_{k=1}^{NbRec_i} (RecT_k^i - SendT^i) \right] \quad (16)$$

3) *Saved Rebroadcasts*: This evaluation metric is used to measure the usage efficiency of the wireless channel interface (50; 14). It determines the average number of rebroadcasts saved while disseminating the messages. The higher the rebroadcasts are saved, the lower the allocation and contention on the shared channel. Given that the number of disseminated message is $NbMsgs$, the number of intended vehicles that successfully receive a message (i) is $NbRec_i$, and the number of intended vehicles that rebroadcast the received message (i) is $NbReb_i$; the average Saved Rebroadcasts (SR) is computed as follows:

$$SR = \frac{1}{NbMsgs} \sum_{i=1}^{NbMsgs} \frac{(NbRec_i - NbReb_i)}{NbRec_i} \quad (17)$$

4) *Energy Consumption*: This evaluation metric helps to measure the effectiveness of the designed data dissemination protocol in terms of energy usage. Reducing the consumed energy helps to extend the lifespan of the modern energy-constrained vehicles, and vice versa is correct. Let $StEner_i$ represent the initial energy storage of vehicle i , $ReEner_i$ denote the residual energy of vehicle i at the end of the simulation, and $NbVehi$ be the total number of vehicles. The average energy consumption per vehicle, denoted as EC , is computed as follows:

$$EC = \frac{1}{NbVehi} \sum_{i=1}^{NbVehi} ReEner_i - StEner_i \quad (18)$$

5) *Computation load*: Optimizing the computation load is essential for achieving timely processing of information, thus lower dissemination latency. Let us assume that $TStart_i$ is the time when a vehicle i becomes a relay node, $TEnd_i$ is the time when the vehicle i finishes to send the message, and $NbVehi$ is the total number of vehicles. The average energy consumption per vehicle, denoted as CL , is computed as given below:

$$CL = \frac{1}{NbVehi} \sum_{i=1}^{NbVehi} TEnd_i - TStart_i \quad (19)$$

5.3. Numerical results and performance analysis

Fig. 10 shows the dissemination coverage ratio among three protocols for varying vehicular densities under the Manhattan-Grid and LuST scenarios. From this figure, it is apparent that the dissemination coverage is less effective in low node densities. The reason is that in poor vehicle density, the network connectivity can not be ensured, hence the probability of finding one complete routing path between two far nodes becomes low. For a better clarification of this case, Fig. 11 shows the dissemination coverage as a function of the distance from the originator vehicle (i.e., the vehicle that trigger the disseminated message) under the sparse network scenario, e.g., node density ≤ 50 vehicles/Km. For the lowest vehicular density (30 vehicles/km), the information coverage is sharply decreasing as the distance from the originator vehicle increase. This means that the higher the distance from the sender, the smaller the number of available links within that distance. In average, it can be observed that our proposed BACKNET-HSR exhibits much better performance compared to CBF and BDSC for both considered scenarios under the sparse networks. For a node density ≤ 50 vehicles/km under the LuST scenario, BACKNET-HSR can reaches on average more than 81% of the participating vehicles, while only 60% and 48% of vehicles are covered by CBF and BDSC respectively. In reality, this is already expected since both CBF and BDSC adopt an indiscriminate inhibition of the relay candidates (please refer to Subsection 2.3), which becomes a serious problem

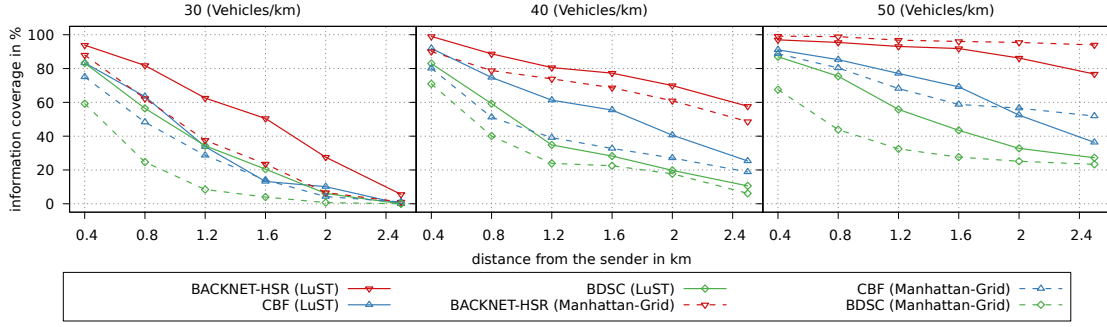

Figure 11: Mean information coverage vs the distance from the originator vehicle for different low vehicular density scenarios.

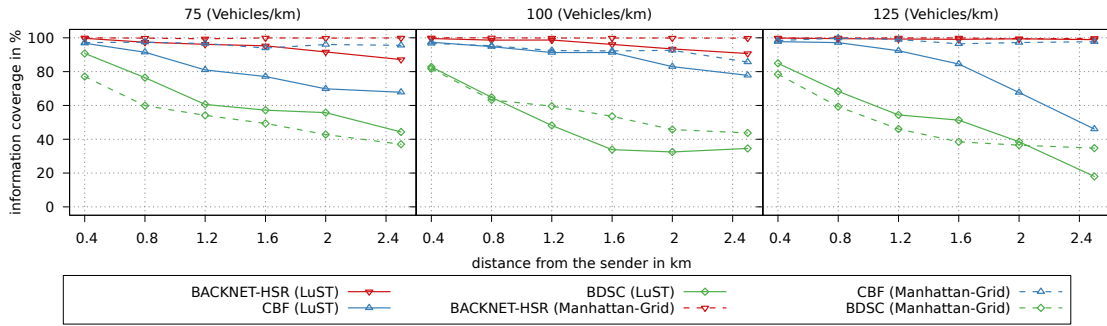

Figure 12: Mean information coverage vs the distance from the originator vehicle for medium to high vehicular density scenarios.

when the number of available next hop relays is small. Also, we can see that the indiscriminate inhibition effect is more remarkable under the Manhattan Grid scenario, where BACKNET-HSR improves the dissemination coverage by approximately 24% and 42% with respect to CBF and BDSC. This is due to the fact that vehicles under the Manhattan Grid scenario follow only a vertical and horizontal distribution with sufficient spaces between parallel road lines to minimize the variety of available next hop relays in terms of polar distribution, making the issues described in Fig. 3 more reproducible. Summing up, BACKNET-HSR exhibits much better performance in terms of the coverage capability compared to CBF and BDSC for the low vehicular densities scenarios. For instance, it can achieve more than 90% of the coverage ratio under relatively sparse networks (e.g., 50 vehicles/km) while only 75% and 68% of vehicles are covered in CBF and BDSC respectively, which suggests that considering the vehicular distribution brings a significant enhancement in terms of the dissemination coverage.

By increasing vehicle density, the network fragmentation becomes less possible and the number of available links toward far vehicles increases, resulting in the improvement of the coverage ratio for all the protocols as shown in Fig. 12. However, for the case of CBF, when exceeding one density threshold, e.g., vehicle density = 100 vehicles/km for the LuST scenario, the coverage ratio starts to decline as the distance from the originator increases. The reason is that CBF adopts a distance based relays selection mechanism, hence the probability of finding equidistant neighbors from

the sender (i.e., with equal transmission timers) in dense scenario is high. As a result, more data collision will occur because of the simultaneous rebroadcasts from nearby nodes, which subvert the availability of the network and affect the coverage capability. This problem is less likely to occur in the Manhattan grid scenario since, as described earlier, the neighbors of each sender vehicle (i.e. the contender nodes) can be only distributed following a vertical and/or horizontal road structures. Hence, the number of contender vehicles having similar retransmission timer is reduced, which explains the robustness of CBF's coverage performance in dense scenarios under the Manhattan grid scenario. As shown in Fig. 12, BDSC has an inconsistent coverage performance since it highly depends on the availability of the selected next hop relays.

By comparison, besides to the indiscriminate selection of relays, BDSC adopts only an explicit selection of relays, making it the most affected by the issue of the frequent disconnection of the communication links. As a result, BDSC exhibits the worst performance compared to the other schemes. In CBF, the indiscriminate selection and inhibition of relays leads to low dissemination coverage, especially under sparse scenarios. In contrast, in case of dense network, the number of contender nodes will considerably increase, leading to a serious packets collision problem. As for BACKNET-HSR, by adopting a hybrid selection of relays while respectively adjusting the relays distribution according to the road lines geometry, the latter exhibits the best robustness for varying traffic densities and

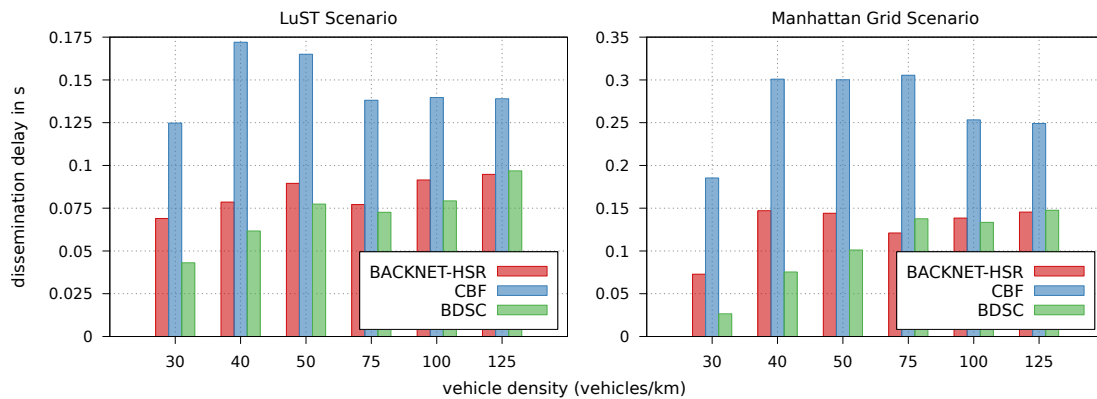

Figure 13: Dissemination delay ratio vs. vehicle density.

for different simulation scenarios. Thus, independently from the considered scenario, BACKNET-HSR is able to cover on average more than 85% of vehicles, as the most effective scheme in terms of the dissemination coverage.

Fig. 13 illustrates the average dissemination delay for different node densities. As expected, CBF has the worst performance for both scenarios, since it involves the contention windows before each retransmission. Compared to BDSC, BACKNET-HSR not only adopts the sender-oriented mechanism during the dissemination process, but also propose the use of the receiver-oriented mechanism as a recovery strategy, thus it adds some extra delay that varies according to the vehicular traffic densities. In fact, for low traffic density (e.g., for 30 vehicles/Km, case of the Manhattan grid), BACKNET-HSR has twice higher dissemination delay compared to BDSC, while they have approximately equivalent delay in case of dense network (e.g., for 125 vehicles/Km of the same scenario). This is simply due to the backup mechanism adopted by BACKNET-HSR that is more used as the node density decreases. As can be seen from Fig. 13, the dissemination delays are much higher for the Manhattan Grid for all three protocols. This is simply because there is less diversity of next relay candidates in the Manhattan grid scenario, hence the sent messages require much more number of hops for reaching vehicles far away from the originator.

For all three protocols, the lowest delay was achieved when the node density is very low (i.e., 30 vehicles/Km). The main reason is that, according to Fig. 11, the dissemination coverage is restricted only to a subset of close nodes, which basically requires few number of retransmissions to be fully covered. They reach a peak when the network density is approximately comprised between 40-75 vehicles/Km (vary according to the considered scenario and/or scheme). In fact, as shown in Fig. 10, the real beginning of the coverage enhancement has occurred with these densities range, meaning that the density becomes higher enough to cover vehicles relatively far away from the message originator. However, it does not become higher enough to ensure the optimal behavior of the dissemination process, especially for CBF and in smaller proportion for BACKNET-HSR and

BDSC. For CBF, the involved back-off timers depend on the distance from the sender nodes. As a result, for low and medium densities, there is no guarantee to find one neighbor far enough from the sender to ensure the rapid propagation of messages. Therefore, the near neighbors are responsible for rebroadcasting the sent message, however with an expended back-off timers. As already stated, the delay incurred by BACKNET-HSR in that range of node densities is mainly due to the adopted backup mechanism, designed to compensate the mismatching of the envisioned propagation pattern with the low vehicular densities. BDSC appears as the less affected by this phenomena, because it adopts a simple sender-oriented dissemination process. By increasing the network density, we reach the optimal behavior of the dissemination process, which can noticeably reduce the transmission delay. However, when exceeding one threshold, e.g., 75 vehicles/Km for the Lust scenario, we observe a slight increase in the transmission delay. Actually, this fact can be attributed to the collision problem in dense vehicular scenarios as described earlier, since the delay mounting can be due to the channel allocation and competition caused by the extra overhead in these particular scenarios. This rise in delay is less remarkable under the Manhattan Grid scenario since, as stated before, the collision problem is less likely to be occurred in this scenario.

Fig. 14 illustrates the saved rebroadcasts ratio for the investigated protocols and for varying vehicular densities under both considered scenarios. For BACKNET-HSR, due to the proposed propagation pattern, the number of rebroadcasts mainly depends on the considered road maps topology. The higher the number of roads, the higher the number of rebroadcasts. On the other hand, the broadcast decision in CBF and BDSC is mainly based on the distance and/or the link stability factors, independently from how the vehicular traffic is distributed. This is confirmed by the fact that the saved-rebroadcasts of BACKNET-HSR are noticeably improved under the Manhattan Grid scenario (the one with the lowest number of roads), while it remains the same for the other investigated protocols.

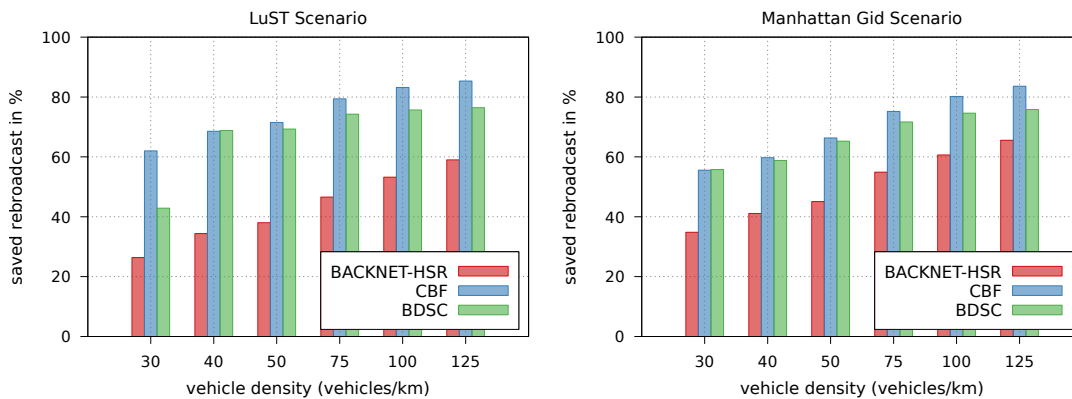

Figure 14: Saved rebroadcasts ratio vs. vehicle density.

In general, as can be seen in both considered scenarios, BACKNET-HSR has the lowest saved-rebroadcasts, especially in case of sparse networks (the case where BACKNET-HSR noticeably improves the information coverage). In reality, this suggests the trade-off between the coverage requirement and the overhead constraints. Meanwhile, it is observed from Fig. 14 that the increase of the traffic density leads to more and more convergence between BACKNET-HSR and the two other protocols, which means that BACKNET-HSR exhibits more robustness with respect to the traffic density variation. In other words, in order to achieve better dissemination coverage, the propagation pattern designed for BACKNET-HSR tends to fit the road topology maps, independently from the vehicular traffic density. In fact, in low and medium densities (≤ 75 vehicles/Km) for all three protocols, the amount of the saved-rebroadcasts is increased linearly with the increase of the traffic density. However, for CBF and BDSC, this improvement becomes less remarkable when exceeding that range of densities (> 75 vehicles/Km). For the case of CBF, this confirms our previous analysis about its poor performance in terms of information coverage and delay in dense networks, since the packets collision are basically stemming from the simultaneous rebroadcasts among vehicles with similar back-off timers, resulting in an additional communication burden. In BDSC, the adopted relays selection algorithm is highly dependent on the link quality between vehicles. This means that, in dense networks, it is more likely that a given relay elects its near neighbors as the next relaying vehicles, which can noticeably increase the number of multi-hop retransmissions.

Fig. 15 presents the average energy consumption per vehicle across various network densities. The results reveal that BACKNET-HSR exhibits higher energy consumption compared to CBF and BDSC, especially in low and medium vehicle densities (i.e., the scenarios where BACKNET-HSR has low saved rebroadcast and enhanced information coverage). This outcome can be attributed to the fact that BACKNET-HSR has the highest number of vehicles actively engaged in transmitting and receiving states, which results in additional energy usage. Furthermore, it can be observed

from this figure that the average energy consumption increases as the vehicle density rises until reaching a certain threshold (approximately 50-75 vehicles/km). Beyond this threshold, the consumed energy begins to decline slightly. The reason is that, starting from this range of vehicle densities, the information coverage experiences a considerable improvement whereas the enhancement in saved broadcasts becomes progressively less significant. In other words, the number of vehicles engaged in the transmitting state and the percentage of vehicles that activated the receiving state are likely to become more and more stable. Taking into account that the transmission power is higher than the receiving power by approximately 35%, the average consumed energy per vehicle is slightly decreased as the vehicle density increases.

Fig. 16 illustrates the average computation time required for a relay node to broadcast one message. Unlike CBF, BACKNET-HSR and BDSC involve the use of a relay selection algorithm to explicitly select the next hop relays. As a result, these algorithms may exhibit significantly higher computation loads. However, it should be noted that these relay selection algorithms operate proactively, ensuring that the additional computation loads do not adversely affect the dissemination latency. As shown in Fig. 16, CBF achieves the shortest computation time since its message sending process includes only the serialization and position filling operations. In contrast, both BDSC and BACKNET-HSR introduce an additional operation to incorporate the explicitly selected relay list inside the message. The computation time of the latter operation depends on the size of the incorporated relay list, which is set to 12 for BDSC, and varies between one (in the case of in-road propagation pattern) and the number of overlapped roads (in the case of inter-road propagation pattern) for BACKNET-HSR. Consequently, BDSC and BACKNET-HSR likely have similar computation time, with a slight advantage for BACKNET-HSR due to its smaller relay list size. The observed increase in computation time, as the vehicle density rises, can be attributed to the underlying architecture of the simulation framework. As the number of vehicles grows, the framework needs to handle a large volume of message passing and event scheduling. This

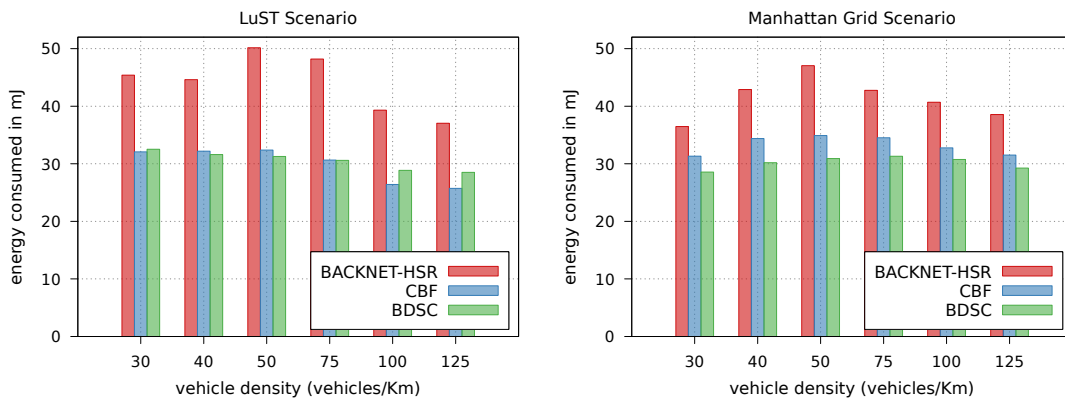

Figure 15: Consumed energy per node vs. vehicle density

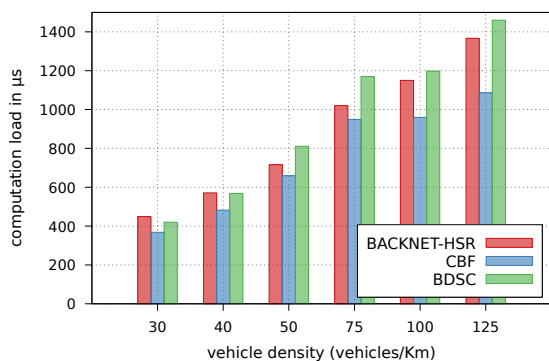

Figure 16: Computation load vs. vehicle density (LuST Scenario)

leads to higher computational overheads, hence resulting in longer computation times.

5.4. Practical implications and limitations

This section discusses the practical implications and limitations of the proposed approach. Firstly, by adjusting the relay selection and inhibition rules based on an envisioned relay distribution model, it becomes possible to effectively mitigate the chaotic distribution and indiscriminate inhibition of relays. This, in turn, ensures better information coverage, leading to improved awareness and response among vehicles within VANETs. Secondly, rather than exclusively adopting a single relay selection mechanism and solely focusing on its associated limitations (i.e., frequent disconnection of links in sender-oriented mechanism and expended latency in receiver-oriented mechanism, as described in subsection 2.3), an ordered combination of both mechanisms in one hybrid scheme can effectively tackle these limitations simultaneously. Thereby, critical information can be delivered quickly to the relevant vehicles, which enhance the response time and decision-making in VANETs.

To validate the above practical implications, we conduct experimental simulations on realistic VANET communication and mobility scenarios. Although simulations substantiate the underlying suggestions, it is important to acknowledge that deploying the proposed approach in a real-world

scenario may still face additional challenges. In fact, these challenges arise from the reliance of our proposed approach on certain widely used assumptions, especially the accuracy of the adopted positioning device and the heterogeneity of the network. BACKNET-HSR imposes strong constraints on the accuracy of the positioning device since both relay selection and inhibition rules depend on the geographic position of vehicles. Achieving this assumption in real-world scenario may be challenging, but it becomes feasible with the recent advances in sensor fusion and tracking algorithms. Network heterogeneity arises from the diversity of communication capabilities and technologies embedded within vehicles from various manufacturers. While the standardization efforts of communication protocols may promote seamless interoperability within VANETs, there are additional challenges resulting from the heterogeneity of the embedded hardware devices. For example, most of the existing communication protocols in VANETs, including BACKNET-HSR, rely on the similarity of the communication range across all vehicles (i.e., all vehicles have equal transmission range). Since our approach emphasizes a monitoring process based on the oriented redundancy of messages to capture link disconnections, it will generate extra overheads in the case where the previous-hop relay has a greater transmission range than the current-hop relay. Sender-oriented solutions are less affected by this issues because conventional vehicular communication does not involve acknowledgment (ACK) messages for the broadcast packets (14).

6. Conclusion

In this work, we developed a Robust BACKbone NETWORK based on Hybrid Selection of Relays (BACKNET-HSR) to solve a series of challenging problems of data dissemination in VANETs. The goal is to ensure the timely delivery of public interest messages under different traffic densities and complex urban scenarios. Firstly, we aim to overcome the problems stemming from the chaotic distribution of relays by designing an efficient relays distribution model suitable to the city settings and some specific characteristics of VANETs. The relays selection and inhibition rules are comprehensively adjusted to realize the envisioned

distribution model in a distributed manner and without any extra overheads. To do this, we design one new message propagation pattern to build an on-the-fly backbone network that integrates a subset of potential relay nodes distributed parallel to the road lines, enabling messages to be disseminated in a structured manner with less signal blocking. Moreover, our proposed scheme addresses the trade-off between latency and reachability in sender-oriented and receiver-oriented mechanisms by exploiting the best features of both mechanisms in one hybrid scheme. To do this, an explicit selection of the relays is adopted as the primary relays selection algorithm, enabling a continuous retransmission at the application layer to ensure low dissemination latency. As the explicit selection of relays has a high sensitivity with the frequent disconnection of the link connections in VANETs, an implicit selection of relays is adopted as a recovery strategy to compensate for the lost packets each time a link failure is occurred. In a word, a tight coupling of both sender-oriented and receiver-oriented mechanisms is realized in one hybrid scheme to enhance the robustness of the relays selection algorithm.

Numerical simulation results reveal that our proposed BACKNET-HSR provides an interesting improvement compared to other typical dissemination protocols under two different simulation scenarios, particularly in terms of information coverage capability and latency. However, it adds some extra overheads depending on the considered road-map topology. The applicability of other relays distribution models without loss of BACKNET-HSR generality is an open issue in our future extension of this work. Meanwhile, it should be noted that BACKNET-HSR's relays distribution model is designed as the first part of a misbehavior reporting scheme with the ability of distributed data merging. BACKNET-HSR will be used to poll the vehicles roaming inside an area of interest to report their own misbehavior analysis. Then, we will exploit the coverage capability of the realized in-road backbones to merge the aggregated reports and backward the results toward the misbehavior authority.

References

- [1] M. Lee, T. Atkison, Vanet applications: Past, present, and future, *Vehicular Communications* 28 (2021) 100310. doi:<https://doi.org/10.1016/j.vehcom.2020.100310>.
- [2] H. Shahwani, S. A. Shah, M. Ashraf, M. Akram, J. P. Jeong, J. Shin, A comprehensive survey on data dissemination in vehicular ad hoc networks, *Vehicular Communications* (2021) 100420.
- [3] J. B. Kenney, Dedicated short-range communications (dsrc) standards in the united states, *Proceedings of the IEEE* 99 (7) (2011) 1162–1182.
- [4] A. Ayoub, G. Khalil, L. Yingzhuang, M. Chowdhury, T. Al, Efficiency broadcast base safety message bsm through vanet based on transmit packet coding (tpc), in: 2020 IEEE 2nd Global Conference on Life Sciences and Technologies (LifeTech), 2020, pp. 383–387. doi:[10.1109/LifeTech48969.2020.1570616937](https://doi.org/10.1109/LifeTech48969.2020.1570616937).
- [5] ETSI, Intelligent transport systems (its); vehicular communications; basic set of applications; part 2: Specification of cooperative awareness basic service, en 302 637-2 v1.4.1, ETSI.
- [6] C. Wu, S. Ohzahata, T. Kato, A low latency path diversity mechanism for sender-oriented broadcast protocols in vanets, *Ad Hoc Networks* 11 (7) (2013) 2059–2068.
- [7] M. Arif, G. Wang, M. Z. A. Bhuiyan, T. Wang, J. Chen, A survey on security attacks in vanets: Communication, applications and challenges, *Vehicular Communications* 19 (2019) 100179.
- [8] N. Wisitpongphan, O. K. Tonguz, J. S. Parikh, P. Mudalige, F. Bai, V. Sadekar, Broadcast storm mitigation techniques in vehicular ad hoc networks, *IEEE Wireless Communications* 14 (6) (2007) 84–94.
- [9] ETSI, Intelligent transport systems (its); vehicular communications; geonetworking; part 4: Geographical addressing and forwarding for point-to-point and point-to-multipoint communications; sub-part 1: Media-independent functionality, en 302 636-4-1 v1.4.1, ETSI.
- [10] R. Tizvar, M. Abbaspour, A density-aware probabilistic interest forwarding method for content-centric vehicular networks, *Vehicular Communications* 23 (2020) 100216.
- [11] L. A. Villas, A. Boukerche, G. Maia, R. W. Pazzi, A. A. Loureiro, Drive: An efficient and robust data dissemination protocol for highway and urban vehicular ad hoc networks, *Computer Networks* 75 (2014) 381–394.
- [12] O. Rehman, M. Ould-Khaoua, H. Bourdoucen, An adaptive relay nodes selection scheme for multi-hop broadcast in vanets, *Computer Communications* 87 (2016) 76–90.
- [13] C. Ghorai, I. Banerjee, A robust forwarding node selection mechanism for efficient communication in urban vanets, *Vehicular Communications* 14 (2018) 109–121.
- [14] O. Rehman, M. Ould-Khaoua, A hybrid relay node selection scheme for message dissemination in vanets, *Future Generation Computer Systems* 93 (2019) 1–17.
- [15] M. Dighiriri, G. M. Lee, T. Baker, Big data environment for smart healthcare applications over 5g mobile network, in: *Applications of big data analytics*, Springer, 2018, pp. 1–29.
- [16] L. Liu, C. Chen, T. Qiu, M. Zhang, S. Li, B. Zhou, A data dissemination scheme based on clustering and probabilistic broadcasting in vanets, *Vehicular Communications* 13 (2018) 78–88.
- [17] O. Amador, M. Uruena, M. Calderon, I. Soto, Evaluation and improvement of etsi its contention-based forwarding (cbf) of warning messages in highway scenarios, *Vehicular Communications* 34 (2022) 100454. doi:<https://doi.org/10.1016/j.vehcom.2022.100454>.
- [18] I. Turcanu, P. Salvo, A. Baiocchi, F. Cuomo, T. Engel, A multi-hop broadcast wave approach for floating car data collection in vehicular networks, *Vehicular Communications* 24 (2020) 100232.
- [19] X. Zhang, X. Cao, L. Yan, D. K. Sung, A street-centric opportunistic routing protocol based on link correlation for urban vanets, *IEEE Transactions on Mobile Computing* 15 (7) (2016) 1586–1599. doi:[10.1109/TMC.2015.2478452](https://doi.org/10.1109/TMC.2015.2478452).
- [20] S. Ullah, G. Abbas, M. Waqas, Z. H. Abbas, S. Tu, I. A. Hameed, Eemds: An effective emergency message dissemination scheme for urban vanets, *Sensors* 21 (5). doi:[10.3390/s21051588](https://doi.org/10.3390/s21051588).
- [21] R. Oliveira, C. Montez, A. Boukerche, M. S. Wangham, Reliable data dissemination protocol for vanet traffic safety applications, *Ad Hoc Networks* 63 (2017) 30–44.
- [22] C. Wu, S. Ohzahata, T. Kato, A low latency path diversity mechanism for sender-oriented broadcast protocols in vanets, *Ad Hoc Networks* 11 (7) (2013) 2059–2068, theory, Algorithms and Applications of Wireless Networked Robotics Recent Advances in Vehicular Communications and Networking. doi:<https://doi.org/10.1016/j.adhoc.2012.02.007>.
- [23] S. Wang, Q. Zhang, G. Chen, V2v-covad: A vehicle-to-vehicle cooperative video alert dissemination mechanism for internet of vehicles in a highway environment, *Vehicular Communications* (2021) 100418.
- [24] O. K. Tonguz, N. Wisitpongphan, F. Bai, Dv-cast: A distributed vehicular broadcast protocol for vehicular ad hoc networks, *IEEE Wireless Communications* 17 (2) (2010) 47–57.
- [25] S. Poursajadi, M. H. Madani, Adaptive optimal relay selection in cooperative vehicular communications under security constraints, *Vehicular Communications* (2021) 100360.
- [26] X. Zeng, M. Yu, D. Wang, A new probabilistic multi-hop broadcast protocol for vehicular networks, *IEEE Transactions on Vehicular Technology* 67 (12) (2018) 12165–12176. doi:[10.1109/TVT.2018.2872998](https://doi.org/10.1109/TVT.2018.2872998).

- [27] A. Srivastava, A. Prakash, R. Tripathi, Fuzzy-based beaconless probabilistic broadcasting for information dissemination in urban vanet, *Ad Hoc Networks* 108 (2020) 102285.
- [28] D. Reina, S. Toral, P. Johnson, F. Barrero, A survey on probabilistic broadcast schemes for wireless ad hoc networks, *Ad Hoc Networks* 25 (2015) 263–292. doi:<https://doi.org/10.1016/j.adhoc.2014.10.001>.
- [29] A. Bujari, M. Conti, C. De Francesco, C. E. Palazzi, Fast multi-hop broadcast of alert messages in vanets: An analytical model, *Ad Hoc Networks* 82 (2019) 126–133. doi:<https://doi.org/10.1016/j.adhoc.2018.07.024>.
- [30] M.-C. Chuang, M. C. Chen, Deep: Density-aware emergency message extension protocol for vanets, *IEEE Transactions on Wireless Communications* 12 (10) (2013) 4983–4993. doi:[10.1109/TWC.2013.090413.121697](https://doi.org/10.1109/TWC.2013.090413.121697).
- [31] H. Yoo, D. Kim, Roff: Robust and fast forwarding in vehicular ad-hoc networks, *IEEE Transactions on Mobile Computing* 14 (7) (2015) 1490–1502. doi:[10.1109/TMC.2014.2359664](https://doi.org/10.1109/TMC.2014.2359664).
- [32] T. Bellache, O. Shagdar, S. Tohme, Dcc-enabled contention based forwarding scheme for vanets, in: 2017 IEEE 13th International Conference on Wireless and Mobile Computing, Networking and Communications (WiMob), 2017, pp. 1–8. doi:[10.1109/WiMob.2017.8115767](https://doi.org/10.1109/WiMob.2017.8115767).
- [33] S. Ukkusuri, L. Du, Geometric connectivity of vehicular ad hoc networks: Analytical characterization, *Transportation Research Part C: Emerging Technologies* 16 (5) (2008) 615–634.
- [34] ETSI, Intelligent transport systems (its); vehicular communications; basic set of applications; local dynamic map (ldm), en 302 895 v1.1.1, ETSI.
- [35] H. Wu, R. Fujimoto, G. Riley, Analytical models for information propagation in vehicle-to-vehicle networks, in: IEEE 60th Vehicular Technology Conference, 2004. VTC2004-Fall. 2004, Vol. 6, IEEE, 2004, pp. 4548–4552.
- [36] ETSI, Intelligent transport systems (its); vehicular communications; basic set of applications; part 3: Specifications of decentralized environmental notification basic service, etsi en 302 637-3 - v1.3.1 (april 2019), ETSI.
- [37] M. Ren, L. Khoukhi, H. Labiod, J. Zhang, V. Vèque, A mobility-based scheme for dynamic clustering in vehicular ad-hoc networks (vanets), *Vehicular Communications* 9 (2017) 233–241. doi:<https://doi.org/10.1016/j.vehcom.2016.12.003>.
- [38] ETSI, Intelligent transport systems (its); security; pre-standardization study on misbehaviour detection; release 2, tr 103 460 v2.1.1 (2020-10), ETSI.
- [39] R. Kaur, R. K. Ramachandran, R. Doss, L. Pan, The importance of selecting clustering parameters in vanets: A survey, *Computer Science Review* 40 (2021) 100392. doi:<https://doi.org/10.1016/j.cosrev.2021.100392>.
- [40] O. AlFarraj, A. Tolba, S. Alkhalaf, A. AlZubi, Neighbor predictive adaptive handoff algorithm for improving mobility management in vanets, *Computer Networks* 151 (2019) 224–231. doi:<https://doi.org/10.1016/j.comnet.2019.01.020>.
- [41] A. Varga, R. Hornig, An overview of the omnet++ simulation environment, in: Proceedings of the 1st international conference on Simulation tools and techniques for communications, networks and systems & workshops, 2008, pp. 1–10.
- [42] C. Sommer, R. German, F. Dressler, Bidirectionally coupled network and road traffic simulation for improved ivc analysis, *IEEE Transactions on mobile computing* 10 (1) (2010) 3–15.
- [43] J. Toutouh, E. Alba, An efficient routing protocol for green communications in vehicular ad-hoc networks, in: Proceedings of the 13th annual conference companion on Genetic and evolutionary computation, 2011, pp. 719–726.
- [44] D. Krajzewicz, J. Erdmann, M. Behrisch, L. Bieker, Recent development and applications of sumo-simulation of urban mobility, *International journal on advances in systems and measurements* 5 (3&4).
- [45] M. Naderi, M. Ghanbari, Adaptively prioritizing candidate forwarding set in opportunistic routing in vanets, *Ad Hoc Networks* 140 (2023) 103048.
- [46] L. Codecá, R. Frank, S. Faye, T. Engel, Luxembourg sumo traffic (lust) scenario: Traffic demand evaluation, *IEEE Intelligent Transportation Systems Magazine* 9 (2) (2017) 52–63.
- [47] L. Codeca, R. Frank, T. Engel, Luxembourg sumo traffic (lust) scenario: 24 hours of mobility for vehicular networking research, in: 2015 IEEE Vehicular Networking Conference (VNC), IEEE, 2015, pp. 1–8.
- [48] O. Amador, M. Urueña, M. Calderon, I. Soto, Evaluation and improvement of etsi its contention-based forwarding (cbf) of warning messages in highway scenarios, *Vehicular Communications* 34 (2022) 100454. doi:<https://doi.org/10.1016/j.vehcom.2022.100454>.
- [49] H. I. Abbasi, R. C. Voicu, J. A. Copeland, Y. Chang, Towards fast and reliable multihop routing in vanets, *IEEE Transactions on Mobile Computing* 19 (10) (2020) 2461–2474. doi:[10.1109/TMC.2019.2923230](https://doi.org/10.1109/TMC.2019.2923230).
- [50] O. M. H. Rehman, H. Bourdoucen, M. Ould-Khaoua, Forward link quality estimation in vanets for sender-oriented alert messages broadcast, *Journal of Network and Computer Applications* 58 (2015) 23–41.