



HAL
open science

MIP-based heuristics for combinatorial design of reconfigurable rotary transfer machines for production of multiple parts

Olga Battaïa, Alexandre Dolgui, Nikolai Guschinsky

► **To cite this version:**

Olga Battaïa, Alexandre Dolgui, Nikolai Guschinsky. MIP-based heuristics for combinatorial design of reconfigurable rotary transfer machines for production of multiple parts. *International Journal of Production Economics*, 2023, 262, pp.108904. 10.1016/j.ijpe.2023.108904 . hal-04232231

HAL Id: hal-04232231

<https://hal.science/hal-04232231v1>

Submitted on 21 Jan 2024

HAL is a multi-disciplinary open access archive for the deposit and dissemination of scientific research documents, whether they are published or not. The documents may come from teaching and research institutions in France or abroad, or from public or private research centers.

L'archive ouverte pluridisciplinaire **HAL**, est destinée au dépôt et à la diffusion de documents scientifiques de niveau recherche, publiés ou non, émanant des établissements d'enseignement et de recherche français ou étrangers, des laboratoires publics ou privés.

Olga Battaïa, Alexandre Dolgui, Nikolai Guschinsky. MIP-based heuristics for combinatorial design of reconfigurable rotary transfer machines for production of multiple parts. *International Journal of Production Economics*, 2023, 262, pp.108904. [10.1016/j.ijpe.2023.108904](https://doi.org/10.1016/j.ijpe.2023.108904). [hal-04232231](https://hal.archives-ouvertes.fr/hal-04232231)

MIP-based heuristics for combinatorial design of reconfigurable rotary transfer machines for production of multiple parts

Abstract

This paper deals with a problem of the optimal configuration of a rotary transfer machine with turrets for machining multiple parts. This is a hard combinatorial optimization problem appearing at the preliminary machine design stage. Such machines are multi-positional, i.e. parts are sequentially machined on several working positions. At each working position, several machining modules (spindle heads) can be installed to process the tasks assigned to this position. Machining modules are activated sequentially or simultaneously. Sequential activation is realized by the use of turrets. Simultaneous activation is possible if machining modules are related to the different sides of the part, and if they can work in parallel. There are horizontal and vertical spindle heads, and turrets to access different sides of the parts on a working position. At the preliminary design stage, the following decisions must be made: the choice of orientations of the parts on the rotary table; the partitioning of the given set of tasks into positions and their assignment to machining modules (selection or design of machining modules to use), and the choice of cutting modes for each spindle head and turret. The objective is to minimize the total cost of equipment used. The number of possible solutions for this combinatorial design problem increases exponentially with the number of part types to be produced, and this represents a computational burden for decision-makers (usually process engineers). In this paper, in order to help decision makers deal efficiently with the manufacturing of multiple batches of parts, we develop a powerful heuristic framework which can be used in real life industrial cases. We test the developed methodology on the real-life cases provided by one of our industrial partners and demonstrate its efficiency. The proposed model and algorithms allow to minimize the cost of designed machines.

Keywords: Machining economics, preliminary machine design, combinatorial optimization, batch machining, line balancing, reconfigurable manufacturing systems.

1. Introduction

The use of decision aid tools to help process engineers design efficient machining systems is an important issue in production economics (Hitomi, 1996). The first work on such problems was initiated for mass production systems only machining one type of part. The solution techniques developed were based on graph theory, mathematical programming and the

application of other solution approaches primarily employed for assembly line balancing (Boysen et al, 2008; Battaïa and Dolgui, 2013; Battaïa and Dolgui, 2022). Examples of such models can be found in (Szadkowski, 1971; Szadkowski, 1997; Dolgui et al., 1999; Dolgui et al., 2009).

In the current manufacturing context, in order to respond to volatile markets, manufacturing systems need to increase their flexibility and reconfigurability. These new circumstances make the design problem even more challenging and complex than in the case of mass production systems, but provide new opportunities for the development of competitive advantages if designed appropriately. A comparison of the profitability of a reconfigurable manufacturing system and several dedicated manufacturing systems, each of them used for a given product, was carried out in (Dolgui et al., 2021).

We consider in this paper the case of a reconfigurable machine with a rotary table. According to Cesar et al. (2020), Reconfigurable Manufacturing Systems (RMS) represent the link between reconfigurability, strategy and technology in order to support frequent changes and evolutions in markets. In fact, the reconfigurability of manufacturing systems plays a primordial role in the responsiveness of the Supply Chain (Koren et al., 2017). Since its introduction by Koren et al. (1999), the concept of RMS has gained a lot of attention both in academia and in practice (Bortolini et al., 2018; Yelles-Chaouche et al., 2020; Pansare et al., 2021a, 2021b; Gu and Koren, 2022).

Different families of optimization approaches have been developed in the literature in order to support decision makers in design, planning and operation of RMS. These include multi-criteria decision making (Goyal et al., 2012; Chaube et al., 2012; Khezri et al., 2021), fuzzy techniques (Singh et al., 2007; Abdi 2009), artificial intelligence algorithms (Li et al., 2019), optimization methods (Youssef and ElMaraghy, 2006; Massimi et al., 2020) including metaheuristics (Dou et al., 2021; Khettabi et al., 2021).

To achieve efficiency in the implementation of RMS, several optimization problems must be properly addressed starting with the preliminary design of the system (Battaïa et al., 2015, 2020, 2021; Goyal and Jain, 2015), the choice of its layout (Haddou Benderbal and Benyoucef, 2019), configuration management (Moghaddam et al., 2017; Ashraf and Hasan, 2018; Wang et al., 2018; Massimi et al., 2020; Singh et al., 2021), process planning (Battaïa et al., 2017a; Xia et al, 2018; Khezri et al., 2021), setup planning and scheduling (Dou et al., 2016). The more integrated is the tool developed, considering many problems and system parameters at the same time, the more efficient are the results obtained, from a resource use point of view. Bensmaine et al. (2014) considered integrated process planning and scheduling in RMS. Dou et al. (2016, 2012) dealt with integrated configuration generation and scheduling for reconfigurable flow lines. Battaïa et al. (2017a) studied an integrated process planning and system configuration problem.

In recent studies (Massimi et al., 2020; Khezri et al., 2020), more attention is paid to the impact of the use of RMS on the sustainability of production systems. Massimi et al. (2020) developed a heuristic-based, non-linear mixed integer approach for minimizing energy consumption by selecting the most suitable modular machines from a set of candidate machines in a sustainable reconfigurable manufacturing environment. Khezri et al. (2020) studied a multi-objective integer linear programming with three criteria: the total production time, cost and the sustainability-metric value related to liquid hazardous waste and greenhouse gas emissions. Moreover, the last objective was split in two, namely: the amount of the greenhouse gases emitted by machines and the hazardous liquid wastes. The first two objectives were also used by Khettabi et al. (2021) who developed a non-linear multi-objective integer program for which several evolutionary approaches have been developed.

The reconfigurability of the manufacturing systems significantly increases their complexity and the number of possible manufacturing system configurations (Farid, 2017). Therefore, the optimisation of such systems raises new challenges for system designers, process planners and production managers (Battaïa et al., 2021).

This paper yields a methodological support for decision makers in order to provide them with fast and efficient solutions for the preliminary design of reconfigurable rotary transfer machines with turrets for machining multiple parts (see Fig. 1). The number of possible configurations of such a machine increases exponentially with the number of different parts to be produced. The study is the first attempt in the literature to model the considered problem mathematically as a combinatorial optimization problem. Due to the solution methods developed in this article, the designers can deal efficiently with the computational burden.

On rotary machines, parts are sequentially machined on m (1, 2, ..., m) working positions. The zero position of the machine is exclusively used for loading and unloading operations. At other positions, several machining modules (spindle heads) can be installed, with a sequential or parallel intervention on the parts. Turrets are used for sequential activation of spindle heads. Parallel intervention is possible on the part, since the horizontal and vertical spindle heads (separate or mounted in turrets) can access its different sides (Battaïa et al., 2017ab).

In our study, motivated by a long-time collaboration with a company designing machining equipment, designers can use only one vertical turret or vertical spindle head mounted at a single position but capable of covering all working positions. Several horizontal spindle heads or turrets can be used, but only one per position. Fig. 1 shows an example of design solution with 6 working positions, where a common vertical spindle head is used on positions 1, 3, 4, 5, two horizontal turrets are installed on position 1 and 3, and one horizontal spindle head is used on position 4.

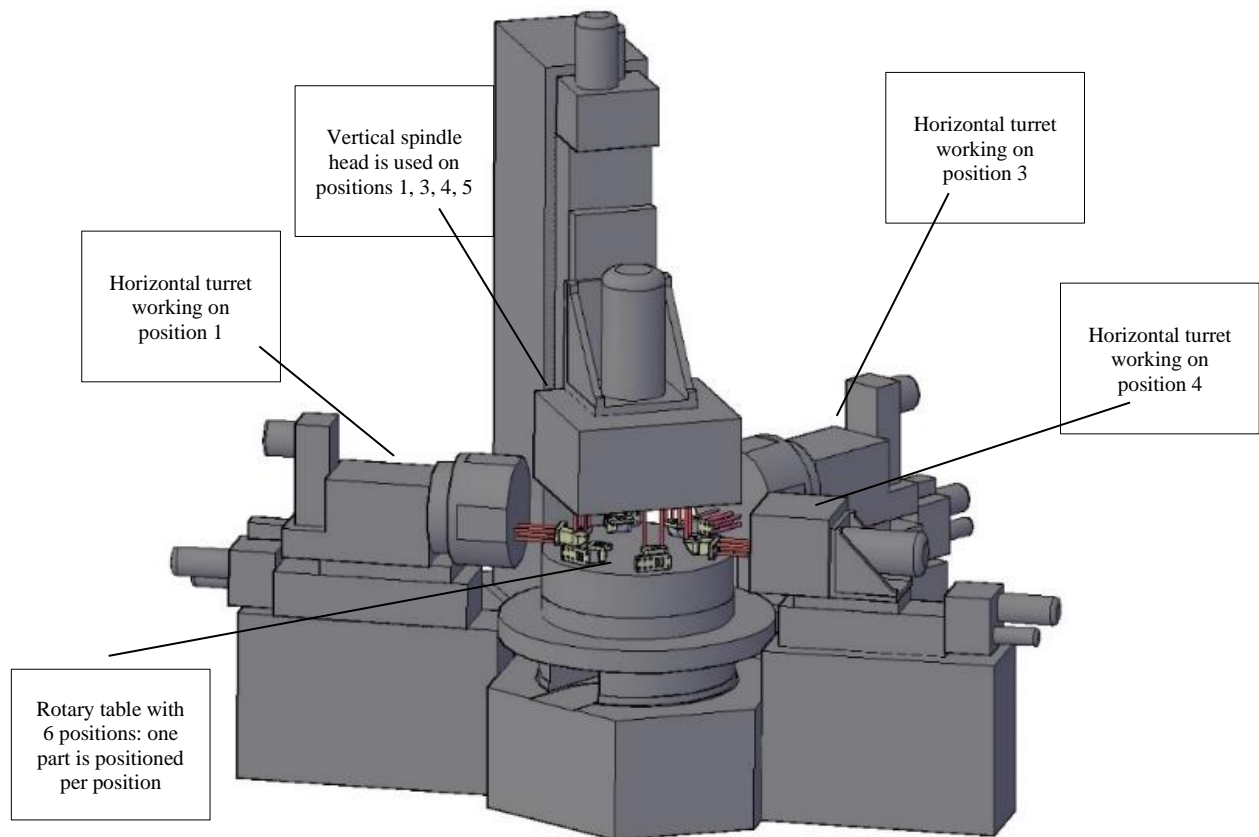

Figure 1. A rotary transfer machine with turrets.

At the preliminary design stage, the designers have to decide:

- how to place each part on the rotary table,
- which tasks to execute for each part at each working position,
- the spindle heads and turrets to be installed and the cutting modes for them.

The quality of these decisions impacts the cost and productivity of the machine. In this paper, we develop a methodological support to help designers to take design decisions at this step which are as close as possible to optimum.

In this paper, integrated process (equipment) design and task assignment is considered for the preliminary design of a reconfigurable rotary machine. Such machines are widely used in automotive, mechanical equipment and aerospace industries. The machine is configured for batch production of different parts. During our long-term collaboration with our industrial partner designing rotary machines, we have worked on several related optimization problems in the past. Initially, we studied the design of mass production rotary machines for single product manufacturing (Dolgui et al., 2009). Then, the variety-oriented design of rotary production systems was investigated in (Battaia et al., 2015). Later on, we considered the integrated process planning and system configuration for such machines (Battaia et al., 2017ab) for the particular case of mixed-model machining. Contrary to all these previous studies, in this paper, we deal

with batch production on reconfigurable rotary machines. To the best of our knowledge, this is the first attempt in the literature to address this problem.

Previously, the design of multi-part machining lines was addressed in (Dolgui et al., 2014), but for only for sequentially executed tasks and with need of setup between different parts. In this case, the main optimization objective was to minimize the number of stations and the second objective was to minimize the setup cost. As a consequence, the developed model is not suitable for the setting considered in this paper. We can also mention studies on assembly line design for Printed Circuit Boards (PCB) which have some similarities with the machining lines considered in this article (Ho and Ji, 2010; Sun et al., 2005). Nevertheless, the differences in technologies, the induced technical constraints and parameters make those models inapplicable for the combinatorial design of reconfigurable rotary transfer machines for production of multiple parts.

In Section 2, we define the general optimization framework. In Section 3, we develop the methodological support based on mathematical models and heuristic algorithms. In Section 4, the results of case studies are reported and discussed. Concluding remarks and research perspectives are given in Section 5.

2. Problem statement

We consider the problem of combinatorial design and task assignment of a rotary transfer machine with m working positions for machining d_0 types of parts with required output O_d , $d = 1, 2, \dots, d_0$.

In practice, batch production can be organized on rotary machines in the following three modes:

- different parts of a batch are machined sequentially (problem \mathbf{A}_1);
- different parts of a batch are machined simultaneously (problem \mathbf{A}_2);
- different batches of parts are machined sequentially (problem \mathbf{A}_3).

In the first case, the rotary transfer machine is reconfigured once the processing of O_d parts of type d is finished, i.e. the fixtures of parts are changed and some spindles are mounted or dismounted if necessary.

In the second case, the parts are loaded in sequence $\pi = (\pi_1, \pi_2, \dots, \pi_{\mu_0})$, where $\pi_i \in \{0, 1, 2, \dots, d_0\}$, $i = 1, 2, \dots, \mu_0$, μ_0 is multiple to $m_0 + 1$ ($\pi_i = 0$ means that no part is loaded). We define m_0 as a maximum possible value of m which depends on the type of the rotary machine to be designed. In this case, no reconfiguration of the rotary transfer machine is allowed during the processing of a batch, but can be done when batch mix changes. We assume $O^d = \eta^d$, $d = 1, 2, \dots, d_0$, where η^d is the occurrence number of d in π . Using sequence π , we can define in a one-to-one manner function $\pi(i, k)$ of part number on the k -th working position.

In the third case, the parts are grouped in \aleph batches with required output O_v , $v=1,2,\dots, \aleph$, which are processed sequentially. Parts of v -th batch are loaded in sequence $\pi_v=(\pi_{v1}, \pi_{v2}, \dots, \pi_{v\mu_v})$, where $\pi_{vj} \in \{0, 1, 2, \dots, d_0\}$, $j=1, 2, \dots, \mu_v$, μ_v is multiple of m_0+1 , ($\pi_{vi}=0$ means that no part is loaded). Using sequences π_v , we can define in a one-to-one manner function $\pi_v(i,k)$, $i=1,\dots, O_v\mu_v+m_0-1$, of part number on the k -th working position after i turns of the rotary table.

In this case, $O^d = \sum_{v=1}^{\aleph} O_v \eta^{dv}$, $d=1, 2, \dots, d_0$, where η^{dv} is the occurrence number of d in π_v .

After the end of a current batch, the rotary transfer machine is reconfigured, i.e. the fixtures of parts are changed and some spindles are mounted or dismounted if necessary.

Let \mathbf{N}^d be the set of machining operations (tasks) needed for machining of elements of the d -th part $d=1, 2, \dots, d_0$, located on n_d sides.

Let N_s^d , $s=1, 2, \dots, n_d$, be a subset of operations for machining of elements of the s -th side of part d . Part d can be located at the zero position in different orientations $\mathbf{H}(d)$ that can be represented by matrix $(h_{rs}(d))_{r=1,s=1}^{r_d, n_d}$, where $h_{rs}(d)$ equals j , $j=1,2$, if the elements of the s -th of the part d can be machined by spindle head or turret of type j . The choice of the part orientation defines which sides of the part will be accessible for horizontal spindle heads, and which only for vertical ones.

Let $\mathbf{N} = \bigcup_{d=1}^{d_0} \mathbf{N}^d$. All operations $p \in \mathbf{N}$ are characterized by the following parameters:

- the length $\lambda(p)$ of the working stroke for operation $p \in \mathbf{N}$, i.e. the distance run by the tool in order to complete operation p ;

- range $[\gamma_1(p), \gamma_2(p)]$ of feasible values of feed rate which characterizes the machining speed;

- set $H(p)$ of feasible orientations of the part (indexes $r \in \{1, 2, \dots, r_d\}$ of rows of matrix $\mathbf{H}(d)$)

for execution of operation $p \in N_s^d$ by spindle head or turret of type j (vertical, if $h_{rs}(d)=1$, and horizontal, if $h_{rs}(d)=2$).

There is no solution if $\bigcap_{p \in N_s^d} H(p) = \emptyset$ for some $d \in \{1, 2, \dots, d_0\}$ and $s \in \{1, 2, \dots, n_d\}$.

Let subset N_k , $k=1,\dots,m$ contain the operations from set \mathbf{N} assigned to the k -th working position. Let sets N_{k1} and N_{k2} be the sets of operations assigned to working position k that are concerned by vertical and horizontal machining, respectively. Finally, let b_{kj} be the number of machining modules (not more than b_0) of type j installed at the k -th working position and, respectively, subsets N_{kjl} , $l=1,\dots,b_{kj}$ contain the operations from set N_{kj} assigned to the same machining module. This assignment has to respect the technological constraints of the machining process required. These can be grouped in the three following families.

A number of known technological factors (such as fixed sequences of operations for machining part elements, the presence of roughing, semi-finishing and finishing operations, etc.) determines an order relation on the set \mathbf{N} , which defines possible sequences of operations. These precedence constraints can be specified by a directed graph $G^{OR}=(\mathbf{N},D^{OR})$, where an arc $(p,p')\in D^{OR}$ if and only if the operation p has to be executed before the operation p' . It should be noted that if such operations p and p' belong to different sides of the part then they cannot be executed at the same position without violating the precedence constraint.

The required precision (tolerance) of mutual disposition of machined part elements as well as a number of additional factors imply the necessity of performing some pairs of operations from \mathbf{N} at the same working position, by the same turret, by the same spindle head or even by the same spindle (for different parts) for each pair. Such inclusion constraints can be given by undirected graphs $G^{SP}=(\mathbf{N},E^{SP})$, $G^{ST}=(\mathbf{N},E^{ST})$, $G^{SM}=(\mathbf{N},E^{SM})$ and $G^{SS}=(\mathbf{N},E^{SS})$, where the edges $(p,p')\in E^{SS}$ ($(p,p')\in E^{SM}$, $(p,p')\in E^{ST}$, $(p,p')\in E^{SP}$) if, and only if, operations p and p' must be executed by the same spindle, at the same machining module (turret, position).

At the same time, the possibility of performing operations from \mathbf{N} at the same working position, by the same turret or by the same spindle head, is also defined by a number of constructional and technological constraints, for instance, mutual influence of combining operations, possibility of tool location in spindle head, turret, etc. These exclusion constraints can also be defined by undirected graphs $G^{DM}=(\mathbf{N},E^{DM})$, $G^{DT}=(\mathbf{N},E^{DT})$, and $G^{DP}=(\mathbf{N},E^{DP})$ where the edge $(p,p')\in E^{DM}$ ($(p,p')\in E^{DT}$, $(p,p')\in E^{DP}$) if, and only if, operations p and p' cannot be executed by the same machining module (turret, position).

Infeasible combinations of part orientations are given by a set E^{DH} . Each $e = \{(d_1,r_1),(d_2,r_2),\dots,(d_k,r_k)\}$ represents a collection of pairs (part number d and row number of $\mathbf{H}(d)$). These simultaneously prohibit orientation r_1 for part d_1 , orientation r_2 for part d_2 , and orientation r_k for part d_k . The set E^{DH} includes $\{(r',d'),(r'',d'')\}$, if there exist $p\in N_{s'}^{d'}$, $s'\in\{1,\dots,n_{d'}\}$, $q\in N_{s''}^{d''}$, $s''\in\{1,\dots,n_{d''}\}$ such that $(p,q)\in E^{SS}\cup E^{SM}\cup E^{ST}$ and $h_{r's'}(d')\neq h_{r''s''}(d'')$.

Let $P=\langle P_1,\dots,P_k,\dots,P_m\rangle$ be a design decision with $P_k=(P_{1k11},P_{2k11},\dots,P_{d_0k11},\dots,P_{1k1b_{k1}},P_{2k1b_{k1}},\dots,P_{d_0k1b_{k1}},P_{1k21},P_{2k21},\dots,P_{d_0k21},\dots,P_{1k2b_{k1}},P_{2k2b_{k1}},\dots,P_{d_0k2b_{k1}})$, $dkjl=(N_{dkjl},\Gamma_{dkjl})$,

$$P_{dkj}=(N_{dkjl}|l=1,\dots,b_{kj}), P_{dk}=(N_{dkj}|j=1,2), \text{ and } \mathbf{N}_j = \bigcup_{d=1}^{d_0} \bigcup_{k=1}^m \bigcup_{l=1}^{b_{kj}} N_{dkjl}, j=1,2.$$

The execution time $t^b(P_{dkjl})$ of operations from N_{dkjl} with the feed per minute $\Gamma_{dkjl}\in[\max\{\gamma_1(p)|p\in N_{dkjl}\}, \min\{\gamma_2(p)|p\in N_{dkjl}\}]$ is equal to (1):

$$t^b(P_{dkjl})=L(N_{dkjl})/\Gamma_{dkjl}+\tau^a, \quad (1)$$

where $L(N_{dkjl})=\max\{\lambda(p)|p\in N_{dkjl}\}$, and τ^a is the time for advance and disengagement of tools.

We assume that if the turret of type j is installed at the k -th position, then the execution time of operations from N_{dkjl} is equal to (2):

$$t^h(P_{dkj}) = \tau^s b_{kj} + \sum_{l=1}^{b_{kj}} t^b(P_{dkjl}), \quad |j=1, 2, \quad (2)$$

where τ^s is the additional time for one rotation of turret. If the spindle head is installed, then $t^h(P_{dkj}) = t^b(P_{dkjl})$, $|j=1, 2$. If all N_{dkjl} are empty, then $t^h(P_{dkj}) = 0$. If $b_{kj} = 1$ then $t^h(P_{dkj}) = t^b(P_{dkj1})$.

The execution time $t^p(P_{dk})$ is defined as in (3):

$$t^p(P_{dk}) = \tau^r + \max\{t^h(P_{dkj}) | j=1, 2\}, \quad (3)$$

where τ^r is the additional time for table rotation.

When different parts of a batch are machined sequentially, then the time t^d for machining all the elements of the d -th part is equal to (4):

$$t^d(P) = \max\{t^p(P_{dk}) | k=1, \dots, m\}. \quad (4)$$

Taking into account that, at the beginning and the end of machining of O^d parts, not all the working positions are occupied, the total time $T(P)$ for machining O^d parts is equal to (5):

$$T(P) = \sum_{d=1}^{d_0} t^d(P)(O^d + m - 1). \quad (5)$$

When different parts of a batch are machined simultaneously, then time $T(P)$ of execution of all corresponding operations after μ_0 turns of rotary table is defined as in (6):

$$T(P) = \sum_{i=1}^{\mu_0} \max\{t^p(P_{\pi(i,k)k}) | k=1, \dots, m_0\}. \quad (6)$$

When different batches of parts are machined sequentially, then the time $T_v(P)$ of execution of all corresponding operations after μ_v turns of rotary table is defined as in (7):

$$T_v(P) = \sum_{i=1}^{O_v \mu_v + m_0 - 1} \max\{t^p(P_{\pi_v(i,k)k}) | k=1, \dots, m_0\}, \quad (7)$$

and the time $T_v(P)$ for machining all the batches is equal to (8):

$$T(P) = \sum_{v=1}^{\aleph} T_v(P). \quad (8)$$

We assume that the given throughput is provided, if the total time $T(P)$ does not exceed the available time T_0 . It is easy to see that the constraint on the throughput is provided if and only if it is satisfied for $\Gamma_{dkjl} = \min\{\gamma_2(p) | p \in N_{dkjl}\}$, $d=1, \dots, d_0$, $k=1, \dots, m$, $j=1, 2$, $l=1, \dots, b_{kj}$.

Let C_1 , C_2 , C_3 , and C_4 be the relative costs for one position, one turret, one machining module of a turret, and one spindle head, respectively. Since the vertical spindle head (if it is installed) is common for several positions, its size (and therefore the cost) depends on the number of positions to be covered. Let k_{\min}^h and k_{\max}^h be the minimal and maximal positions of the

common vertical spindle head. Then, its cost can be estimated as $C_4 + (k_{\max}^h - k_{\min}^h)C_5$, where C_5 is the relative cost for covering one additional position by a vertical spindle head. If the vertical spindle turret is installed, its cost can be estimated by $C_2 + C_3 b_{k1}$. In a similar way, the cost $C(b_{k2})$ for performing a set of operations N_{k2} by associated b_{k2} machining modules can be assessed as in (9):

$$C(b_{k2}) = \begin{cases} 0 & \text{if } b_{k2} = 0, \\ C_4 & \text{if } b_{k2} = 1, \\ C_2 + C_3 b_{k2} & \text{if } b_{k2} > 1. \end{cases} \quad (9)$$

The machine cost $Q(P)$ is calculated as the total cost of all equipment used, i.e. (10):

$$Q(P) = C_1 m + C_4 \text{sign}(|\mathbf{N}_1|) \left(1 - \sum_{k=1}^m \text{sign}(|N_{k12}|)\right) + \sum_{k=1}^m \text{sign}(|N_{k12}|) (C_2 + C_3 b_{k1}) + C_5 (k_{\max}^h - k_{\min}^h) + \sum_{k=1}^m C(b_{k2}), \quad (10)$$

where $\text{sign}(a) = 1$ if $a > 0$, and $\text{sign}(a) = 0$ if $a \leq 0$.

Since $m = m_0$ for problems \mathbf{A}_2 and \mathbf{A}_3 , we let $C_1 = 0$ in these cases. If the vertical turret is installed, then the second and fourth summands are equal to 0, since $N_{k12} \neq \emptyset$ for some $k \in \{1, \dots, m\}$ and $k_{\max}^h = k_{\min}^h = 0$. If the vertical spindle head is installed, then the second summand is equal to C_4 and the third summand is equal to 0, since $\text{sign}(|\mathbf{N}_1|) = 1$ and $\sum_{k=1}^m \text{sign}(|N_{k12}|) = 0$. If there is no vertical machining, then the second, the third and the fourth

summands are equal to 0, since $\mathbf{N}_1 = \emptyset$, $N_{k12} = \emptyset$, $k = 1, \dots, m$, and $k_{\max}^h = k_{\min}^h = 0$.

The studied problem is to determine:

- a) the number of positions m ;
- b) orientations of parts $\mathbf{H}(d)$;
- c) the number b_{kj} of machining modules of type j ($j=1$ for vertical and $j=2$ for horizontal) installed at the k -th position, $k=1, \dots, m$;
- d) subsets N_{dkjl} of operations from \mathbf{N}^d assigned to the l -th machining module of type j at the k -th position $d=1, 2, \dots, d_0$, $k=1, \dots, m$, $l=1, \dots, b_{kj}$;
- e) the feed per minute Γ_{dkjl} for each subset N_{dkjl} , $d=1, 2, \dots, d_0$, $k=1, \dots, m$, $j=1, 2$, $l=1, \dots, b_{kj}$ in such a way that the machine cost is as small as possible, and none of the constraints are violated.

In the next section, we present mixed-integer programming (MIP) formulations of the considered design problems.

3. MIP formulations

We can build set \mathbf{N}' based on graph $G^{SSM}=(\mathbf{N},E^{SSM}=E^{SS} \cup E^{SM})$. Let $G_i^{SSM}=(N_i^{SSM},E_i^{SSM})$, $i=1,\dots,n^{SSM}$, be connectivity components of G^{SSM} including isolated vertices. Only one vertex (operation or task) \wp_i is chosen from each N_i^{SSM} , let $\chi(p)=\wp_i$ for all $p \in N_i^{SSM}$ and included into \mathbf{N}' . Let us introduce the following notation:

X_{pq} decision variable, equal to 1 if the operation p from \mathbf{N}' is assigned to the block $q=2(k-1)b_0+(j-1)b_0+l$, i.e. l -th machining module of spindle head or turret of type j at the k -th position;

Y_{kj}^{ds} auxiliary variable, equal to 1 if at least one operation from N_s^d is assigned to spindle head or turret of type j at the k -th position;

Y_{kjl}^d auxiliary variable, equal to 1 if at least one task for machining elements of the d -th part is executed in the l -th machining module of spindle head or turret of type j at the k -th position;

Y_{kjl} auxiliary variable, equal to 1 if the l -th machining module of spindle head or turret of type j is installed at the k -th position;

$Y_{1\min}$ auxiliary variable, equal to k if k is the minimal position covered by vertical spindle head or turret;

$Y_{1\max}$ auxiliary variable, equal to k if k is the maximal position covered by vertical spindle head or turret;

Y_1 auxiliary variable which is equal to 1 if the vertical spindle head or turret is installed;

Z_k auxiliary variable, equal to 1 if at least one operation is assigned to the k -th position;

h_r^d auxiliary variable, equal to 1 if elements of the d -th part are machined with the r -th orientation;

F_{kjl}^d an auxiliary variable for determining the time of execution of operations from \mathbf{N}^d in the l -th machining module of spindle head or turret type j at the k -th position;

F_k^d an auxiliary variable for determining the time of execution of operations from \mathbf{N}^d at the k -th position;

Different auxiliary variables are introduced for \mathbf{A}_1 , \mathbf{A}_2 and \mathbf{A}_3 .

For problem \mathbf{A}_1 : F_d is an auxiliary variable which determines the time of execution of all the operations from \mathbf{N}^d ; T_k^d is an auxiliary variable which is equal to F^d if the k -th position exists and 0 otherwise.

For \mathbf{A}_2 : F^i is an auxiliary variable which determines the time of execution of operations from \mathbf{N} at all the positions when machining of part π_i is finished.

For \mathbf{A}_3 : $F^{\cup i}$ is an auxiliary variable which determines the time of execution of operations from \mathbf{N} at all the positions when processing of part $\pi_{\cup i}$ of \cup -th family is finished; $F_s^{\cup i}$ is an

auxiliary variable for determining the time of execution of operations from \mathbf{N} at the first i positions after the i -th turn of the rotary table for processing υ -th family; $F_f^{\upsilon i}$ is an auxiliary variable for determining the time of execution of operations from \mathbf{N} at the last i positions after the $O_{\upsilon\mu_{\upsilon}+m_0-i}$ -th turn of the rotary table for processing υ -th family.

We calculate in advance parameters $t_{pp'} = \max(\lambda(p), \lambda(p'))/\min(\gamma_2(p), \gamma_2(p')) + \tau^a$. They represent the minimal time necessary for the execution of operations p and p' in the same machining module. It is assumed that $(p, p') \in E^{DM}$ if $\min(\gamma_2(p), \gamma_2(p')) < \max(\gamma_1(p), \gamma_1(p'))$. For each operation $p \in \mathbf{N}$, we calculate a set $B(p)$ of block indices from $\{1, 2, \dots, 2m_0b_0\}$ and a set $K(p)$ of position indices from $\{1, 2, \dots, m_0\}$, where operation $p \in \mathbf{N}$ can be potentially assigned.

Let $I(k) = [2(k-1)b_0+1, 2kb_0]$, $I(k, j) = [2(k-1)b_0+(j-1)b_0+1, 2(k-1)b_0+jb_0]$, and $I(k, j, l) = [2(k-1)b_0+(j-1)b_0+l, 2(k-1)b_0+(j-1)b_0+l]$, respectively.

4.1 Cost calculation

The objective can be represented as in (11):

$$\begin{aligned} \text{Min } & C_1 \sum_{k=1}^{m_0} Z_k + C_4 \sum_{k=1}^{m_0} Y_{k21} + (C_2 + 2C_3 - C_4) \sum_{k=1}^{m_0} \sum_{j=1}^2 Y_{kj2} + \\ & C_3 \sum_{k=1}^{m_0} \sum_{j=1}^2 \sum_{l=3}^{b_0} Y_{kjl} + C_4 Y_1 + C_5 (Y_{1\max} - Y_{1\min}) \end{aligned} \quad (11)$$

4.2 Assignment constraints

$$\sum_{q \in B(p)} X_{pq} = 1; p \in \mathbf{N}' \quad (12)$$

$$\sum_{\substack{q \in \bigcup_{k'=1}^{k-1} \bigcup_{j'=1}^2 I(k', j') \cap B(p)}} q X_{\chi(p)q} + \sum_{q \in I(k, j) \cap B(p)} q X_{\chi(p)q} \leq \sum_{q \in I(k, j) \cap B(p')} (q-1) X_{\chi(p')q},$$

$$(p, p') \in D^{OR}; p, p' \in \mathbf{N}; k \in K(p'); j=1, 2 \quad (13)$$

$$\sum_{q \in I(k) \cap B(p)} X_{\chi(p)q} = \sum_{q' \in I(k) \cap B(p')} X_{\chi(p')q'}; (p, p') \in E^{SP}; p, p' \in \mathbf{N}; k \in K(p) \cap K(p') \quad (14)$$

$$\sum_{q \in I(k, j) \cap B(p)} X_{\chi(p)q} = \sum_{q' \in I(k, j) \cap B(p')} X_{\chi(p')q'}; (p, p') \in E^{ST}; p, p' \in \mathbf{N}; k \in K(p) \cap K(p'); j=1, 2 \quad (15)$$

$$\sum_{q \in I(k) \cap B(p)} X_{\chi(p)q} + \sum_{q' \in I(k) \cap B(p')} X_{\chi(p')q'} \leq 1, (p, p') \in E^{DP}; p, p' \in \mathbf{N}; k \in K(p) \cap K(p') \quad (16)$$

$$\sum_{q \in I(k,j) \cap B(p)} X_{\chi(p)q} + \sum_{q' \in I(k,j) \cap B(p')} X_{\chi(p')q'} + Y_{kj2} \leq 2, (p,p') \in E^{DT}; p, p' \in \mathbf{N}; k \in K(p) \cap K(p');$$

$$j=1,2 \quad (17)$$

$$X_{\chi(p)q} + X_{\chi(p')q} \leq 1; (p,p') \in E^{DB}; p, p' \in \mathbf{N}; q \in B(p) \cap B(p') \quad (18)$$

$$X_{\chi(p)q} = 0; p \in N_s^d; d=1, \dots, d_0; s=1, \dots, n_d; k \in K(p);$$

$$\{h_{rs}(d)=j \mid r=1, \dots, r_d\} = \emptyset; q \in I(k,j) \cap B(p) \quad (19)$$

$$\sum_{\substack{q \in B(p) \cap \\ k \in K(p)}} \bigcup_{I(k,j)} X_{\chi(p)q} = \sum_{\substack{q' \in B(p') \cap \\ k \in K(p')}} \bigcup_{I(k,j)} X_{\chi(p')q'}; p, p' \in N_s^d;$$

$$j=1,2; d=1, \dots, d_0; s=1, \dots, n_d \quad (20)$$

$$Y_{kjl}^d \leq \sum_{p \in \mathbf{N}^d, q \in I(k,j,l) \cap B(p)} X_{\chi(p)q};$$

$$d=1, \dots, d_0; k=1, \dots, m_0; j=1,2; l=1, \dots, b_0 \quad (21)$$

$$\sum_{p \in \mathbf{N}^d, q \in I(k,j,l) \cap B(p)} X_{\chi(p)q} \leq |\mathbf{N}^d| Y_{kjl}^d;$$

$$d=1, \dots, d_0; k=1, \dots, m_0; j=1,2; l=1, \dots, b_0 \quad (22)$$

$$Y_{kjl} \leq \sum_{d=1}^{d_0} Y_{kjl}^d; k=1, \dots, m_0; j=1,2; l=1, \dots, b_0 \quad (23)$$

$$\sum_{d=1}^{d_0} Y_{kjl}^d \leq d_0 Y_{kjl}; k=1, \dots, m_0; j=1,2; l=1, \dots, b_0 \quad (24)$$

$$Y_{kjl-1} \geq Y_{kjl}; k=1, \dots, m_0; j=1,2; l=2, \dots, b_0 \quad (25)$$

$$Y_{k12} + Y_{k21} \leq 1; k=1, \dots, m_0 \quad (26)$$

$$Y_1 \leq \sum_{m=1}^{m_0} Y_{k11} \quad (27)$$

$$\sum_{m=1}^{m_0} Y_{k11} \leq m_0 Y_1 \quad (28)$$

$$Z_k \leq Y_{k11} + Y_{k21}; k=1, \dots, m_0 \quad (29)$$

$$Y_{k11} + Y_{k21} \leq 2Z_k; k=1, \dots, m_0 \quad (30)$$

$$(m_0 - k + 1)Y_{k11} + Y_{1\min} \leq m_0 + 1; k=1, \dots, m_0 \quad (31)$$

$$Y_{1\max} \geq kY_{k11}; k=1, \dots, m_0 \quad (32)$$

$$Y_{1\max} \leq m_0 Y_1 \quad (33)$$

$$Y_{1\min} \leq m_0 Y_1 \quad (34)$$

$$Y_{kj}^{ds} \leq \sum_{p \in N_s^d, q \in I(k,j) \cap B(p)} X_{\chi(p)q}; d=1, \dots, d_0; s=1, \dots, n_d; k=1, \dots, m_0; j=1,2 \quad (35)$$

$$\sum_{p \in N_s^d, q \in I(k, j) \cap B(p)} X_{\chi(p)q} \leq |N_s^d| Y_{kj}^{ds}; d=1, \dots, d_0; s=1, \dots, n_d; k=1, \dots, m_0; j=1, 2 \quad (36)$$

$$\sum_{s=1}^{n_d} Y_{k1}^{ds} \leq 1; d=1, \dots, d_0; k=1, \dots, m_0 \quad (37)$$

$$h_r^d \geq 1 - \sum_{s=1}^{n_d} \sum_{j=1, j \neq h_{rs}}^2 Y_{kj}^{ds}; d=1, \dots, d_0; r=1, \dots, n_d \quad (38)$$

$$\sum_{r=1}^{r_d} h_r^d = 1; d=1, \dots, d_0 \quad (39)$$

$$\sum_{(r,d) \in e} h_r^d \leq |e| - 1, e \in E^{DH}, k=1, \dots, m_0 \quad (40)$$

Equations (12) provide the assignment of each operation from \mathbf{N}' exactly to one machining module. Equations (13) – (17) are used to model precedence constraints, inclusion constraints for positions and turrets, as well as exclusion constraints for positions, turrets, and machining modules, respectively. Equations (18) prohibit the assignment of operations from N_s^d to machining modules of type j if there is no feasible orientation of part d for such an execution. Equations (19) guarantee the assignment of operations from N_s^d to the same type of spindle head or turret. Constraints (20) – (25) define the existence of machining module l of type j at position k . Equations (26) – (34) are used to calculate $Z_k, k=1, \dots, m_0, Y_1$, as well as $Y_{1\min}$ and $Y_{1\max}$. Constraints (35) – (40) provide the choice of feasible orientation of each part d .

4.3 Time calculation

$$F_{kjl}^d \geq t_{pp} X_{\chi(p)q}; p \in \mathbf{N}^d; j=1, 2; d=1, \dots, d_0; k=1, \dots, m_0; l=1, \dots, b_0; q \in I(k, j, l) \cap B(p) \quad (41)$$

$$F_{kjl}^d \geq t_{pp'} (X_{\chi(p)q} + X_{\chi(p')q} - 1);$$

$$p, p' \in \mathbf{N}^d; j=1, 2; d=1, \dots, d_0; k=1, \dots, m_0; l=1, \dots, b_0; q \in I(k, j, l) \cap B(p) \cap B(p') \quad (42)$$

$$F_{k11}^d \geq (\lambda(p)/\gamma_2(p') + \tau^a) (X_{\chi(p)q} + X_{\chi(p')q} - 1);$$

$$p \in \mathbf{N}^d; p' \in \mathbf{N}; d=1, \dots, d_0; k, k'=1, \dots, m_0;$$

$$k \neq k' \text{ or } p' \notin \mathbf{N}^d; q \in I(k, 1, 1) \cap B(p); q' \in I(k', 1, 1) \cap B(p') \quad (43)$$

$$F_k^d \geq \sum_{l=1}^{b_0} F_{kjl}^d + 2\tau^g Y_{kj2} + \tau^g \sum_{l=3}^{b_0} Y_{kjl} + b_0 \tau^g (Y_{kj}^d - 1); d=1, \dots, d_0; k=1, \dots, m_0; j=1, 2 \quad (44)$$

Expressions (41) – (42), (43) and (44) are used to estimate the execution times of operations from \mathbf{N}^d by the l -th machining module, vertical spindle head and at the k -th position, respectively.

$$F_d \geq F_k^d + \tau^r; d=1, \dots, d_0; k=1, \dots, m_0 \quad (45)$$

$$T_k^d \geq F_d - T_0(1 - Z_k); d=1, \dots, d_0; k=1, \dots, m_0 \quad (46)$$

$$\sum_{d=1}^{d_0} (F^d O^d + \sum_{k=1}^{m_0} T_k^d - F^d) \leq T_0 \quad (47)$$

$$F^i \geq F_k^{\pi(i,k)} + \tau^r; i=1, \dots, \mu_0; k=1, \dots, m_0 \quad (48)$$

$$\sum_{i=1}^{\mu_0} F^i \leq T_0. \quad (49)$$

$$F^{\upsilon i} \geq F_k^{\pi_{\upsilon}(i,k)} + \tau^r; \upsilon=1, \dots, \aleph; i=1, \dots, \mu_{\upsilon}; k=1, \dots, m_0 \quad (50)$$

$$F_s^{\upsilon i} \geq F_k^{\pi_{\upsilon}(i,k)} + \tau^r; \upsilon=1, \dots, \aleph; i=1, \dots, m_0-1; k=1, \dots, i \quad (51)$$

$$F_f^{\upsilon i} \geq F_k^{\pi_{\upsilon}(O_{\upsilon} \mu_{\upsilon} + m_0 - i, k)} + \tau^r; \upsilon=1, \dots, \aleph; i=2, \dots, m_0; k=i, \dots, m_0 \quad (52)$$

$$\sum_{\upsilon=1}^{\aleph} (O_{\upsilon} \sum_{i=1}^{\mu_{\upsilon}} F^{\upsilon i} + \sum_{i=1}^{m_0-1} F_s^{\upsilon i} + \sum_{i=2}^{m_0} F_f^{\upsilon i} - \sum_{i=\mu_{\upsilon}-m_0+2}^{\mu_{\upsilon}} F^{\upsilon i}) \leq T_0 \quad (53)$$

Expressions (45) – (47), (48) – (49), and (50) – (53) provide the required productivity for problems **A**₁, **A**₂ and **A**₃, respectively.

4.4 Bound constraints

$$X_{pq} \in \{0, 1\}; p \in \mathbf{N}'; q \in B(p) \quad (54)$$

$$Y_{kj}^{ds} \in \{0, 1\}; k=1, \dots, m_0; j=1, 2; d=1, \dots, d_0; s=1, \dots, n_d \quad (55)$$

$$Y_{kjl}^d \in \{0, 1\}; k=1, \dots, m_0; j=1, 2; l=1, \dots, b_0; d=1, \dots, d_0 \quad (56)$$

$$Y_{kjl} \in \{0, 1\}; k=1, \dots, m_0; j=1, 2; l=1, \dots, b_0 \quad (57)$$

$$Y_{1\min}, Y_{1\max} \in \{0, 1, \dots, m_0\}; k=1, \dots, m_0; j=1, 2; l=1, \dots, b_0 \quad (58)$$

$$Y_1 \in \{0, 1\} \quad (59)$$

$$Z_k \in \{0, 1\}; k=1, \dots, m_0 \quad (60)$$

$$F_{kjl}^d \in [0, \bar{t}_k^d - \tau^r]; k=1, \dots, m_0; j=1, 2; l=1, \dots, b_0; d=1, \dots, d_0 \quad (61)$$

$$F_k^d \in [0, \bar{t}_k^d - \tau^r]; k=1, \dots, m_0; d=1, \dots, d_0 \quad (62)$$

$$F_d \in [\underline{t}^d, \bar{t}^d]; d=1, \dots, d_0 \quad (63)$$

$$F^i \in [\underline{T}^i, \bar{T}^i]; i=1, \dots, \mu_0 \quad (64)$$

$$F^{\upsilon i} \in [\underline{t}^{\upsilon i}, \bar{t}^{\upsilon i}]; \upsilon=1, \dots, \aleph; i=1, \dots, \mu_{\upsilon} \quad (65)$$

$$F_s^{\upsilon i} \in [\max\{\underline{t}^{\pi_{\upsilon}(i,k)} \mid k=1, \dots, i\}, \max\{\bar{t}_k^{\pi_{\upsilon}(i,k)} \mid k=1, \dots, i\}]; \upsilon=1, \dots, \aleph; i=1, \dots, m_0-1 \quad (66)$$

$$F_f^{vi} \in [\max\{ \underline{t}^{\pi_v(O_v \mu_v^{-i,k})} \mid k = i, \dots, m_0 \}, \max\{ \bar{t}_k^{\pi_v(O_v \mu_v^{-i,k})} \mid k = i, \dots, m_0 \}];$$

$$v=1, \dots, \aleph; \quad i=2, \dots, m_0 \quad (67)$$

where, for problem \mathbf{A}_1 : $\underline{t}^d = \max\{ \lambda(p)/\gamma_2(p) + \tau^a + \tau^r \mid p \in \mathbf{N}^d \}$; $\bar{t}_k^d = (T_0 - \sum_{d'=1, d' \neq d}^{d_0} \underline{t}^{d'} O^{d'}) / O^d$,

for problem \mathbf{A}_2 : $\underline{T}^i = \max\{ \underline{t}^{\pi(i,k)} \mid k = 1, \dots, m_0 \}$, $\bar{T}^i = T_0 - \sum_{i'=1, i' \neq i}^{\mu_0} \underline{T}^{i'}$ and

$$\bar{t}_k^d = \max\{ \bar{T}^i \mid i = 1, \dots, \mu_0, \pi(i, k) = d \},$$

and for problem \mathbf{A}_3 :

$$\underline{t}^{vi} = \max\{ \underline{t}^{\pi_v(m_0 - 2 + i, k)} \mid k = 1, \dots, m_0 \}, \quad \bar{t}^{vi} = (T_0 - O_v \sum_{v'=1, v' \neq v}^{\aleph} \sum_{i'=1}^{\mu_{v'}} \underline{t}^{v'i'}) / O_v - \sum_{i'=1, i' \neq i}^{\mu_v} \underline{t}^{vi'}$$
 and

$$\bar{t}_k^d = \max\{ \bar{t}^{vi} \mid v = 1, \dots, \aleph, i = 1, \dots, \mu_v, \pi_v(m_0 - 2 + i, k) = d \}.$$

4.5 Calculations of $B(p)$ and $K(p)$

Based on matrices $\mathbf{H}(d)$ and the set E^{DH} , we can build a matrix \mathbf{H} of possible orientations of all parts. Each row of \mathbf{H} defines in a one-to-one manner the orientation H and the corresponding partition of \mathbf{N} to \mathbf{N}_1 and \mathbf{N}_2 . For such a partition, we can calculate $B(p, H)$ and $K(p, H)$ by using algorithms from (Dolgui *et al.*, 2009; Dolgui *et al.*, 2006). Then, $B(p)$ and $K(p)$ are defined as $B(p) = \bigcup_{H \in \mathbf{H}} B(p, H)$ and $K(p) = \bigcup_{H \in \mathbf{H}} K(p, H)$, respectively.

As has been mentioned, the modelled optimization problem is difficult to tackle as the number of parts to be machined increases. As a consequence, designers need heuristic approaches in order to deal with such problem instances. In the next section, we develop a new heuristic framework in order to provide designers with efficient solution methods for large-scale problems.

4. Heuristics

In this section, we present a heuristic algorithm based on the idea of a heuristic approach developed for mass production machining lines by Guschinskaya *et al.* (2008). This approach is adapted to the case of combinatorial design of reconfigurable rotary transfer machines for production of multiple parts. The main approach used in this heuristic framework is to fix random sets of decision variables and optimize the values of remaining decision variables. This process is repeated during available solution time.

Algorithm 1:

Step 0. Generate the initial population using a greedy heuristic or truncated resolution with a MIP solver.

Step 1. Let $C_{min} = \infty$, $TR_{tot} = 0$, $TR_{nimp} = 0$.

Step 2. Choose two solutions X' and X'' from the population.

Step 3. Let $N^f = \{p \in \mathbf{N}' \mid q^*(p, X') = q^*(p, X'')\}$ where $X_{pq^*(p, X)} = 1$.

Step 4. If $|\mathbf{N}' \setminus N^f| < N_{min}$ a random set is removed from N^f . If $|\mathbf{N}' \setminus N^f| > N_{max}$ a random set is added to N^f .

Step 5. Let $B(p) = \{q^*(p, X')\}$ for $p \in N^f$ and $B(p)$ be unchanged for $p \in \mathbf{N}' \setminus N^f$.

Step 6. Solve the obtained problem (1) – (57) with a MIP solver within time limit T_{MIP} .

Step 7. Compute the value C of the objective function (1) for the obtained solution.

Step 8. Replace the worst solution in the population with the new solution.

Step 9. With probability P_m let $N^f = \mathbf{N}' \setminus N^f$ and execute Steps 4 - 8.

Step 10. If $C_{min} > C$, then set $C_{min} = C$, $TR_{nimp} = 0$ and keep the current solution as the best, set $TR_{nimp} = TR_{nimp} + 1$, otherwise.

Step 11. Set $TR_{tot} = TR_{tot} + 1$.

Step 12. Stop if one of the following conditions holds:

- a given solution time is exceeded;
- TR_{tot} is greater than the maximum number of iterations authorized;
- TR_{nimp} is greater than a given value.

Go to Step 2, otherwise.

The five versions HEUR1, HEUR2, HEUR3, HEUR4 and HEUR5 of the general heuristic framework were developed as follows:

- In HEUR1, model (10) – (67) developed in this paper is used for all sub-problems where only the calculation of the bounds (54) – (60) is adapted to each sub-problem.
- In HEUR2, model (10) – (67) is rebuilt for each sub-problem.
- In HEUR3, all known solutions are grouped in clusters according to the same orientations of all parts to be machined. In this case, only solutions from the same cluster are chosen at Step 2 of Algorithm 1, $B(p)$ are modified according to the orientations of parts and model (10) – (67) is rebuilt.
- HEUR4 and HEUR5 are modified versions of HEUR2 and HEUR3, respectively, where at Step 5 of Algorithm 1, the assignment of any operation $p \in N^f$ can be attributed to any machining module at the corresponding working position.

In order to compare the performances of the developed heuristic methods, we use a number of case studies provided by our industrial partner. The results of this comparison are presented in the next section.

5. Experimental study

6.1. Small industrial case studies

The first dataset includes 25 industrial instances provided by our industrial partner. The characteristics of 25 instances are presented in Table 1.

Examples	N	OSP	DM	DT	DP	SS	SM	m_0+1	LS	NB	d_0	NO
1	92	0.011	0.234	0.339	0.125	0.012	0.021	6	-	d_0	5	4
2	52	0.02	0.434	0.697	0.299	0.027	0.02	6	-	d_0	3	2
3	82	0.013	0.237	0.21	0	0.014	0.008	6	-	d_0	6	8
4	88	0.034	0.297	0.238	0	0.012	0.026	6	-	d_0	6	8
5	90	0.039	0.309	0.246	0	0.011	0.034	6	-	d_0	6	8
6	116	0.01	0.173	0.277	0.046	0.006	0.008	6	-	d_0	8	8
7	70	0.012	0.185	0.164	0.004	0.008	0.011	6	-	d_0	6	16
8	74	0.024	0.22	0.182	0.001	0.008	0.01	6	-	d_0	6	16
9	40	0.026	0.515	0.636	0.164	0.021	0.026	6	-	d_0	2	2
10	48	0.014	0.363	0.369	0.078	0.018	0.018	6	-	d_0	4	4
11	44	0.023	0.013	0.091	0.101	0	0.025	6	-	d_0	4	16
12	92	0.011	0.234	0.339	0.125	0.012	0.021	4	8	1	5	4
13	52	0.02	0.434	0.697	0.299	0.027	0.02	4	4	1	3	2
14	116	0.01	0.174	0.275	0.043	0.006	0.011	6	12	1	8	8
15	70	0.014	0.185	0.164	0.004	0.008	0.011	4	8	1	6	16
16	40	0.026	0.515	0.636	0.164	0.021	0.026	4	4	1	2	2
17	74	0.024	0.22	0.182	0.001	0.008	0.01	6	6	1	6	16
18	40	0.026	0.515	0.636	0.164	0.021	0.026	4	4	1	2	2
19	92	0.011	0.234	0.339	0.125	0.012	0.021	4	8	2	5	4
20	78	0.013	0.24	0.176	0.039	0.007	0.008	4	8	2	6	16
21	80	0.013	0.234	0.175	0.078	0.007	0.009	4	8	2	6	16
22	116	0.01	0.174	0.275	0.043	0.006	0.011	6	12	2	8	8
23	70	0.014	0.185	0.164	0.004	0.008	0.011	4	8	2	6	16
24	48	0.014	0.363	0.369	0.078	0.018	0.018	4	8	2	4	4
25	74	0.024	0.22	0.182	0.001	0.008	0.01	6	12	2	6	16

Table 1 Parameters of industrial problems

In this table, $|\mathbf{N}|$ is the number of operations, OSP is the order strength of precedence constraints, DM, DT, DP, SS, and SM are the densities of graphs G^{DM} , G^{DT} , G^{DP} , G^{SS} , and G^{SM} respectively, LS is the sum of lengths of loading sequences, NB is the number of batches, and NO is the number of rows of matrix \mathbf{H} . Experiments were carried out on an ASUS notebook (1.86 Ghz, 4 Gb RAM) with an academic version of CPLEX 12.2. In Tables 2 and 3, we compare results for CPLEX12.2 (maximal solution time 3600 sec) and the proposed heuristics HEUR1, HEUR2, HEUR3, HEUR4, HEUR5 with $TR_{tot}=200$, $TR_{nimp}=80$, $T_{MIP}=10$ sec, $P_m=0.5$ and maximal solution time 600 sec.

5.2. Results of tests for the small industrial case studies

HEUR1	Examples	HEUR2	HEUR3	HEUR4	HEUR5	CPLEX
67	1	67	67	67	67	67
56	2	56	56	56	56	56
49	3	49	49	49	49	49
49	4	49	49	49	49	49
49	5	49	49	49	49	49
74	6	74	74	74	74	74
62	7	62	62	62	62	62
77	8	77	77	77	77	77
67	9	67	67	67	67	67
63	10	63	63	63	63	63
71	11	71	71	71	71	71
67	12	67	67	67	67	67
56	13	56	56	56	56	56
89	14	89	89	89	89	89
93	15	93	93	93	93	93
65	16	65	65	63	65	63
74	17	74	74	74	74	74
67	18	67	67	67	67	67
67	19	67	67	67	67	67
68	20	68	68	68	68	68
63	21	63	63	63	63	63
89	22	89	89	89	89	89
65	23	65	65	65	65	65
63	24	63	63	63	63	63
87	25	89	89	87	89	87

Table 2 The best value of the objective function

Examples	HEUR1	HEUR2	HEUR3	HEUR4	HEUR5	CPLEX
1	429.1	299.1	43.6	611.8	39.4	4.4
2	25.3	59.6	6.6	158.5	7.8	0.3
3	128.7	203.5	43.9	364.3	45.5	1.4
4	128.8	116	33.5	263.1	33.2	1.1
5	139.1	148.9	30.8	337	30.2	1
6	234	397.3	22.9	600.7	26	2.5
7	113.3	206	9	357	14.4	1.6
8	305.2	91.6	69.8	161.3	13	266.1
9	36.5	64.2	17.1	130.6	16	0.8

10	111.5	147.6	10.6	530.9	12.8	2.4
11	37.9	76.1	44.3	86.6	46.7	2.6
12	138.6	240.5	67.1	498.4	100.1	15.8
13	33.1	56.5	17.1	141.5	22.3	1.6
14	610.5	603.3	94.3	611.1	127.6	58.2
15	76.5	142.7	36.6	219	53.4	3.8
16	37.9	96.2	28.6	151.4	39.6	5.3
17	139.9	202.8	21.6	601.8	45.8	69
18	55.1	89.4	23.3	134.9	28.7	1.8
19	98.7	241	61.8	378.1	90.1	1
20	88.6	120.6	81.4	161.6	87.3	3.1
21	99.1	135	55.6	356.7	66.8	9.9
22	611.7	604.3	84.3	616.8	105.7	11.8
23	58.8	122.5	43.5	257.3	46.1	2.4
24	100.3	127.8	22.1	328.7	30.7	1.5
25	87.8	368.8	6.4	545.5	13.6	35.3

Table 3 Solution time (sec)

The obtained results show that for this dataset all heuristics found optimal solutions for at least 23 problem instances out of 25, i.e. for 92%, HEUR1 found 24 optimal solutions, i.e. 96%, and HEUR4 found all optimal solutions as CPLEX. The solution time for finding optimal solutions was relatively short for all 25 instances, the longest one is less than 1 minute. For 23 problem instances, the shortest time was attained by CPLEX, for 2 problem instances by HEUR3 and for one problem instances by HEUR5. These results show that the heuristic methods developed are capable of finding optimal solutions for small size problem instances. Further, we evaluate their performances on the problem instances of larger size randomly generated on the basis of the data provided by our industrial partner. Random generation is used in order to increase the number of different problem instances tested.

6.3 Results of tests for randomly generated problems of larger size

The second dataset includes 1200 randomly generated problems: 100 for each combination of optimization problem (A_1 , A_2 and A_3) and number of types of parts (4, 6, 8 and 10) to be machined. Their characteristics are presented in Table 4. Constraints were generated using the data provided by our industrial partner.

Table 5 reports the obtained results for all heuristic methods, HEUR1-HEUR5, CPLEX and CPLEXO (with a heuristic solution used for a warm start). The methods are compared on the following indicators: NS is the number of found feasible solutions, OS is the number of found optimal solutions, BS is the number of found best known solutions (for instances which have not been solved to optimality), AD and MD are respectively average and maximal deviations (in percentages) of the found values of the objective function from the best known values, calculated on the basis of 100 instances for each optimization problem and each number of parts

to be machined. The deviations were not calculated if the number of feasible solutions found by a method was less than 100.

d_0	Parameters of problems (value)	N	OSP	DM	DT	DP	SS	SM	A ₁ , A ₃	A ₂	A ₃	
									m0 +1	LS	LS	NB
4	Minimal	44	0.034	0.064	0.026	0	0.027	0	4	4	8	2
	Maximal	95	0.525	0.659	0.659	0.242	0.051	0.016	8	8	16	2
	Average	69	0.106	0.373	0.348	0.024	0.036	0.004	6	6	12	2
6	Minimal	89	0.029	0.003	0.002	0	0.024	0	3	6	6	2
	Maximal	159	0.471	0.462	0.462	0.205	0.031	0.057	9	9	18	2
	Average	124	0.29	0.228	0.197	0.027	0.027	0.016	6	7	12	2
8	Minimal	118	0.023	0.003	0.002	0	0.024	0	3	8	8	2
	Maximal	216	0.456	0.438	0.417	0.214	0.033	0.057	10	12	20	2
	Average	165	0.288	0.197	0.168	0.025	0.028	0.017	6	10	12	2
10	Minimal	251	0.023	0.025	0.021	0	0.014	0	4	12	12	2
	Maximal	255	0.447	0.58	0.588	0.194	0.026	0.045	9	16	27	3
	Average	254	0.16	0.33	0.3	0.03	0.02	0.01	7	13	18	2.5

Table 4 Parameters of problems

d_0	METH	A ₁					A ₂					A ₃				
		NS	OS	BS	AD	MD	NS	OS	BS	AD	MD	NS	OS	BS	AD	MD
4	HEUR1	100	98	98	0.08	5.08	100	80	80	0.89	10.61	100	58	58	2.26	12.5
	HEUR2	100	97	97	0.1	5.08	100	99	99	0.03	3.03	100	96	96	0.09	4.63
	HEUR3	100	98	98	0.08	5.08	100	99	99	0.04	3.61	100	96	96	0.23	10.61
	HEUR4	100	99	99	0.07	6.85	100	99	99	0.05	4.63	100	96	96	0.08	4.63
	HEUR5	100	98	98	0.08	5.08	100	99	99	0.01	1.08	100	98	98	0.06	4.63
	CPLEX	100	100	100	0	0	100	100	100	0	0	100	100	100	0	0
	CPLEXO	100	100	100	0	0	100	100	100	0	0	100	100	100	0	0
6	HEUR1	100	27	27	13.79	62.96	100	66	66	1.14	8.2	100	64	68	1.06	8.2
	HEUR2	100	82	83	1.06	17.78	100	70	72	0.67	5.56	100	70	73	0.74	8.2
	HEUR3	100	61	61	2.73	27.78	100	71	74	0.71	8.2	100	68	74	0.64	8.2
	HEUR4	100	75	76	1.34	12.5	100	70	71	1.16	12.04	100	61	62	1.84	13.93
	HEUR5	100	96	98	0.18	10.61	100	82	89	0.31	8.2	100	79	88	0.27	8.2
	CPLEX	100	98	99	0.05	5.43	100	93	94	0.57	16.81	99	90	90	-	-
	CPLEXO	100	98	99	0.05	5.43	100	93	94	0.51	10.66	100	90	91	0.61	13.89
8	HEUR1	100	29	29	5.44	27.94	100	40	43	3.22	15.6	100	38	40	2.91	16.09
	HEUR2	100	45	45	3.89	29.35	100	46	50	2.15	15.6	100	41	44	2.26	16.09

	HEUR3	100	63	66	1.67	17.65	100	47	56	1.68	12.39	100	48	56	1.63	16.09
	HEUR4	100	41	41	3.92	17.78	100	43	46	2.67	14.68	100	41	44	3.45	15.93
	HEUR5	100	85	92	0.76	17.65	100	63	84	0.38	5.88	100	62	82	0.62	16.09
	CPLEX	98	92	94	-	-	90	67	72	1.58	27.52	88	33	76	-	-
	CPLEXO	100	92	94	1.14	44.33	100	74	84	1.71	23.89	100	76	83	1.37	15.6
10	HEUR1	100	16	19	5.64	21.21	100	33	35	3.3	16.52	100	24	26	3.78	14.68
	HEUR2	100	23	30	3.6	28.79	100	40	44	2.42	12.17	100	37	47	2.15	13.45
	HEUR3	100	28	37	3.22	21.21	100	43	59	1.37	6.19	100	39	51	1.59	9.78
	HEUR4	100	15	20	5.32	21.21	100	31	32	3.74	16.52	100	24	26	3.78	15.22
	HEUR5	100	43	73	0.83	13.64	100	51	82	0.49	6.02	100	52	82	0.48	7.78
	CPLEX	81	65	75	-	-	75	68	71	-	-	69	22	63	-	-
	CPLEXO	100	65	75	2	31.65	100	68	74	1.88	21.18	100	67	74	1.79	13.56

Table 5. Results for randomly generated problems

Table 6 presents a synthesis of the parameters for all problems and all instances. For the tested instances, neither CPLEX nor any heuristic could find all optimal solutions for all problems within limited computational time.

Overall, HEUR5 found more optimal solutions and more solutions with the best value of the objective function than other heuristic methods. Moreover, HEUR5 found more solutions with the best value than CPLEX within limited computational time. In general, CPLEX and CPLEXO provided similar results. However, CPLEXO found more feasible, optimal and best value solutions than CPLEX in total. CPLEXO also provided more optimal and best value solutions than any heuristic method, but has larger average deviation and maximal deviation than heuristic HEUR5 which provided the best results for these indicators.

Method	NS	OS	BS	AD	MD
HEUR1	1200	573	589	3.63	62.96
HEUR2	1200	746	780	1.6	29.35
HEUR3	1200	761	827	1.3	27.78
HEUR4	1200	695	712	2.3	21.21
HEUR5	1200	908	1065	0.37	17.65
CPLEX	1100	928	1034	-	27.52
CPLEXO	1200	1023	1068	0.92	44.33

Table 6. Synthesis of the results for randomly generated problems

Table 7 presents a synthesis of the parameters for all instances per type of problem. We can see that for A_1 , the conclusions are the same as previously and for A_2 and A_3 they are different for

HEUR5. For these problems, HEUR5 found more best value solutions than CPLEXO and still had smaller average and maximal deviations.

METH	A ₁					A ₂					A ₃				
	NS	OS	BS	AD	MD	NS	OS	BS	AD	MD	NS	OS	BS	AD	MD
HEUR1	400	170	173	6.2	62.96	400	219	224	2.1	16.52	400	184	192	2.5	16.09
HEUR2	400	247	255	2.2	29.35	400	255	265	1.3	15.6	400	244	260	1.31	16.09
HEUR3	400	250	262	1.9	27.78	400	260	288	0.95	12.39	400	251	277	1.02	16.09
HEUR4	400	230	236	2.7	21.21	400	243	248	1.9	16.52	400	222	228	2.3	15.93
HEUR5	400	322	361	0.5	17.65	400	295	354	0.3	8.2	400	291	350	0.36	16.09
CPLEX	379	355	368	-	5.43	365	328	337	-	27.52	356	245	329	-	0
CPLEXO	400	355	368	0.8	44.33	400	335	352	1.025	23.89	400	333	348	0.9425	15.6

Table 7. Synthesis of the results per type of optimization problem

	4					6				
	NS	OS	BS	AD	MD	NS	OS	BS	AD	MD
HEUR1	300	236	236	1.08	12.5	300	157	161	5.33	62.96
HEUR2	300	292	292	0.07	5.08	300	222	228	0.83	17.78
HEUR3	300	293	293	0.12	10.61	300	200	209	1.36	27.78
HEUR4	300	294	294	0.07	6.85	300	206	209	1.45	13.93
HEUR5	300	295	295	0.05	5.08	300	257	275	0.25	10.61
CPLEX	300	300	300	0	0	299	281	283	-	16.81
CPLEXO	300	300	300	0	0	300	281	284	0.39	13.89
	8					10				
	NS	OS	BS	AD	MD	NS	OS	BS	AD	MD
HEUR1	300	107	112	3.86	27.94	300	73	80	4.24	21.21
HEUR2	300	132	139	2.77	29.35	300	100	121	2.73	28.79
HEUR3	300	158	178	1.66	17.65	300	110	147	2.06	21.21
HEUR4	300	125	131	3.35	17.78	300	70	78	4.28	21.21
HEUR5	300	210	258	0.59	17.65	300	146	237	0.6	13.64
CPLEX	276	192	242	-	27.52	225	155	209	-	0
CPLEXO	300	242	261	1.4	44.33	300	200	223	1.89	31.65

Table 8. Synthesis of the results per number of parts to be machined

Table 8 presents a synthesis of the parameters for all instances according to the number of types of parts to be machined. We can see that for 4, 6, and 8 types the conclusions are the same as

for Table 6, but for 10 types of parts, HEUR5 found more best value solutions than CPLEXO and still with smaller average and maximal deviations.

From this analysis, we can conclude that the best methods are HEUR5 and CPLEXO. In Figures 2 to 4, we present comparative diagrams of HEUR5 and CPLEXO for all problems and all numbers of types of parts to be machined to compare their performances in more detail.

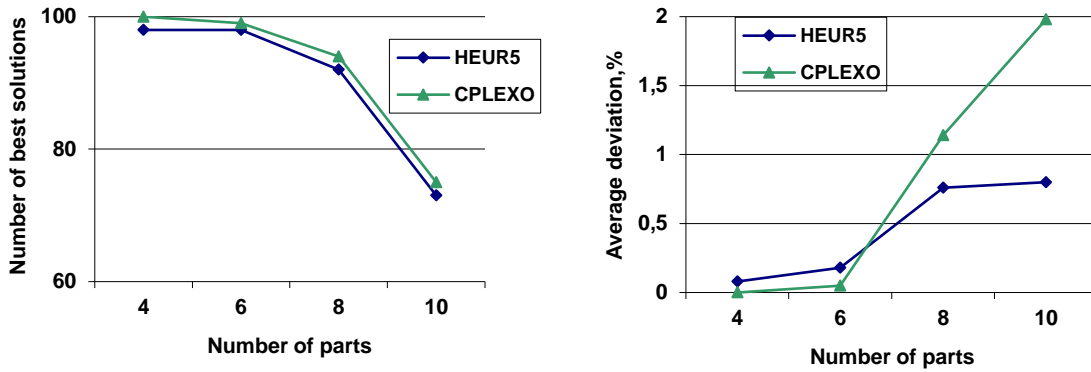

Fig. 2. Comparison of HEUR5 and CPLEXO for A_1

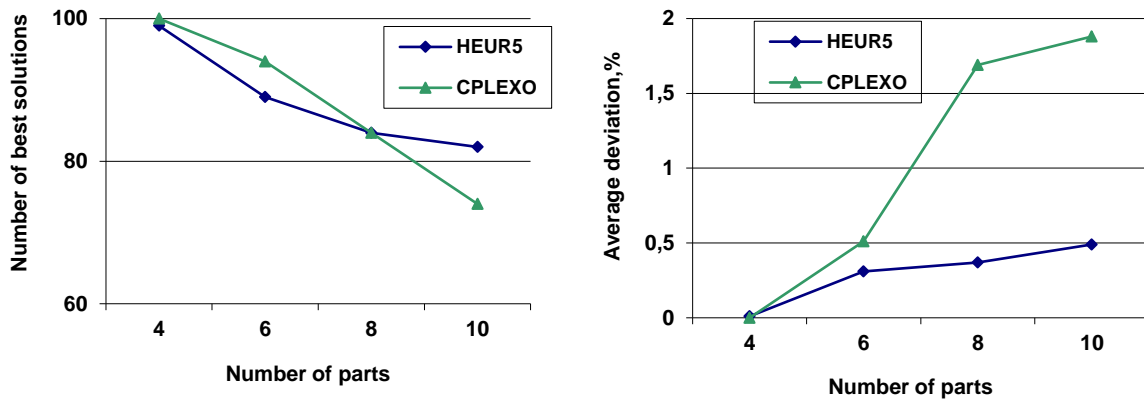

Fig. 3. Comparison of HEUR5 and CPLEXO for A_2

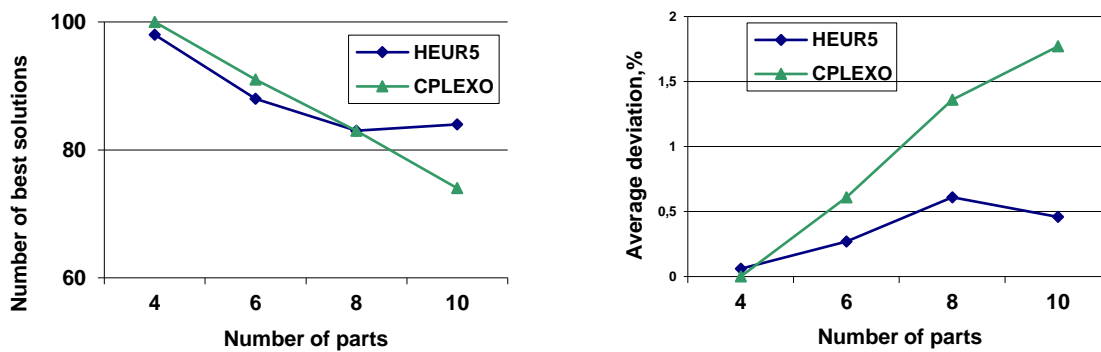

Fig. 4. Comparison of HEUR5 and CPLEXO for A_3

It can be observed that for A_1 , both methods found a comparable number of best solutions and the average deviation is very close for 4 and 6 types of parts, and then becomes much smaller for 8 and 10 types of parts for HEUR5. For A_2 , CPLEXO found more best solutions for 6 and 8 parts and fewer for 10 types of parts. The average deviation grows with the number of parts for CPLEXO and remains smaller for HEUR5. The same can be observed for A_3 .

In conclusion, we can note that HEUR5 could be the best option for large-scale problems, while for medium-scale problems CPLEXO remains the most efficient method.

The analysis of the realized tests shows the applicability of the developed approaches in real-life conditions, where the design of complex reconfigurable rotary transfer machines for production of multiple parts can be substantially improved both in terms of the time reduction and the increase in quality of the obtained solutions. The lines appropriately designed can be used longer and for a more diversified portfolio of machine parts, both advantages improve the competitiveness of the machining systems in the context of volatile markets and frequent customer demand changes.

Conclusion

The preliminary design of reconfigurable machines with rotary tables was considered. The machines are designed for batch production of different products. The mixed integer programming approach is used for modelling the selection of the best configuration and equipment. The selection deals with the simultaneous choice of: process plan; machining modules; machining conditions (cutting speed); line balancing and task assignment. Three classes of problems were considered, each of them for a specific mode of processing different parts. Thus, the models and algorithms proposed in this paper cover a very large range of industrial settings.

The obtained problems are very hard optimization problems with mixed decision variables (discrete and continue). For these new decision problems, mixed integer programming models (MIP) were proposed. The solver Cplex was used to solve real case studies of small size.

For larger instances, five powerful new heuristics were developed and tested, first, on 25 real life problems of relatively moderate sizes, then on a set of randomly generated instances of larger sizes. The results of tests demonstrated the excellent performances of the suggested algorithms. The MIP model allows small instances to be solved quickly. The heuristics obtain similar results in term of quality, but with larger computational time. For large instances, the heuristics outperform the MIP model with Cplex, and give excellent results after a relatively short calculation time.

We can conclude that the proposed models and algorithms can be used for solving very complex real-life problems, exactly or approximately, depending on the size of problem. They can be useful in real life combinatorial design of reconfigurable machines with rotary tables at

the preliminary design stage and help to reduce the computational burden for decision makers.

This study demonstrates how mathematical modelling of complex machining systems can be combined with advanced decision aid techniques to obtain sophisticated, but very efficient models and algorithms applicable in real life manufacturing practice for a range of systems. These are able to improve the decision process drastically as well as the quality of the obtained solutions. Despite the complexity of real-life systems, a large number of specific constraints and dependences among parameters, the article shows that it is possible to develop explainable and powerful mathematical models and algorithms for decision aid, which provides users with efficient solutions in a reasonable time.

This is a pioneer work for the type of reconfigurable machines considered with rotary tables, turrets and machining modules for different modes of processing multiple parts. A profound knowledge of the process and production practices, combined with advanced mathematical tools for decision aid and optimization in the domain of line balancing and scheduling were necessary to reach the objectives of this research.

The article demonstrates that due to the use of sophisticated modelling techniques and operations research approaches, the efficient solution of real-life complex manufacturing problems becomes possible, in spite of their combinatorial complexity and a large number of constraints and interdependent parameters.

Our conclusions are of course limited to the considered classes of reconfigurable rotary machines and for considered modes of batch processing. Further studies will be focused on the introduction of new production modes and technologies as well as on extension of the proposed algorithms for other classes of machining systems. Another possible direction for further research is the introduction of sustainability criteria in the decision process and models (energy consumption, gas emissions, etc.)

Acknowledgements

This research was funded by the region Pays de la Loire, France (Project RMS) and by the National Agency for Scientific Research, France (project ReconfiDurable, ANR-21-CE10-0019-06).

References

- Abdi, M.R. (2009). Fuzzy multi-criteria decision model for evaluating reconfigurable machines. *International Journal of Production Economics*, 117(1):1–15.
- Ashraf, M, Hasan F. (2018). Configuration selection for a reconfigurable manufacturing flow line involving part production with operation constraints. *The International Journal of Advanced Manufacturing Technology*, 98(5–8): 2137–2156.
- Battaïa, O., Dolgui, A. (2013). A taxonomy of line balancing problems and their solution approaches. *International Journal of Production Economics*, 142 (2): 259–277.
- Battaïa, O., Dolgui, A. (2022). Hybridizations in line balancing problems: A comprehensive review on new trends and formulations, *International Journal of Production Economics*, 250: 108673.
- Battaïa, O., Dolgui, A., and Guschinsky, N. (2021). Design of reconfigurable machining lines: A novel

- comprehensive optimisation method. *CIRP Annals*, 70 (1): 393–398.
- Battaïa, O., Dolgui A., Guschinsky N. (2020). Optimal cost design of flow lines with reconfigurable machines for batch production. *International Journal of Production Research* 58(10): 2937–2952.
- Battaïa, O., Dolgui A., Guschinsky N. (2017a). Integrated process planning and system configuration for mixed-model machining on rotary transfer machine. *International Journal of Computer Integrated Manufacturing* 30 (9): 910–925.
- Battaïa, O. Dolgui, A., and Guschinsky, N. (2017b). Decision support for design of reconfigurable rotary machining systems for family part production. *International Journal of Production Research*, 55 (5): 1368–1385.
- Battaïa, O., Brissaud D., Dolgui A., Guschinsky N. (2015). Variety-oriented design of rotary production systems. *CIRP Annals-Manufacturing Technology* 64 (1):411-414.
- Bensmaine, A., Benyoucef L., Dahane D. (2014). A new heuristic for integrated process planning and scheduling in reconfigurable manufacturing systems. *International Journal of Production Research* 52 (12): 3583–3594.
- Bortolini, M., Galizia F.G., Mora C. (2018). Reconfigurable manufacturing systems: Literature review and research trend. *Journal of Manufacturing Systems* 49: 93–106.
- Boysen, N., Flidner, M., Scholl, A. (2008). Assembly line balancing: Which model to use when? *International Journal of Production Economics*, 111 (2): 509–528.
- Cesar, H. Ortega-Jimenez, Pedro Garrido-Vega, Cristian Andrés Cruz Torres, (2020). Achieving plant responsiveness from reconfigurable technology: Intervening role of SCM, *International Journal of Production Economics*, 219, 195–203.
- Chaube, A., Benyoucef L, Tiwari M. K. (2012). An adapted NSGA-2 algorithm based dynamic process plan generation for a reconfigurable manufacturing system. *Journal of Intelligent Manufacturing* 23(4):1141–1155.
- Dolgui, A. Hashemi-Petroodi S. E., Kovalev S., Kovalyov, M.Y. (2021). Profitability of a multi-model manufacturing line versus multiple dedicated lines, *International Journal of Production Economics*, 236: 108113, <https://doi.org/10.1016/j.ijpe.2021.108113>.
- Dolgui, A., Guschinsky, N., and Levin, G. (1999). On problem of optimal design of transfer lines with parallel and sequential operations. In *Proceedings of the 7th IEEE International Conference on Emerging Technologies and Factory Automation (ETFA'99)*, October 18-21, 1999, Barcelona, Spain. J.M. Fuertes (Ed.), IEEE, 1999, vol. 1, pp. 329–334.
- Dolgui A., Finel B., Guschinsky N., Levin G., Vernadat F. (2006). MIP approach to balancing transfer lines with blocks of parallel operations. *IIE Transactions*, 38, 869–882.
- Dolgui, A., Guschinsky, N., and Levin, G. (2009). Graph approach for optimal design of transfer machine with rotary table. *International Journal of Production Research*, 47(2): 321–341.
- Dolgui, A., Kovalev, S., Kovalyov, M.Y., Nossack, J., Pesch, E. (2014). Minimizing setup costs in a transfer line design problem with sequential operation processing, *International Journal of Production Economics*, 151: 186-194.
- Dou, J, Li J, Su C. (2016). Bi-objective optimization of integrating configuration generation and scheduling for reconfigurable flow lines using NSGA-II. *The International Journal of Advanced Manufacturing Technology*,

86(5–8): 1945–1962.

- Dou, J., Li, J., Xia, D., & Zhao, X. (2021). A multi-objective particle swarm optimisation for integrated configuration design and scheduling in reconfigurable manufacturing system. *International Journal of Production Research*, 59(13), 3975–3995.
- Farid, A. M. (2017). Measures of reconfigurability and its key characteristics in intelligent manufacturing systems. *Journal of Intelligent Manufacturing*, 28:353–369.
- Goyal, K., Jain P. K. (2015). Design of reconfigurable flow lines using MOPSO and maximum deviation theory. *The International Journal of Advanced Manufacturing Technology*, 84: 1587–1600.
- Goyal, K. K, Jain P. K, Jain M. (2012). Optimal configuration selection for reconfigurable manufacturing system using NSGA II and TOPSIS. *International Journal of Production Research*, 50(15):4175–4191.
- Gu, X. & Koren, Y. (2022). Mass-Individualisation – the twenty first century manufacturing paradigm, *International Journal of Production Research*, 60 (24): 7572–7587, DOI: 10.1080/00207543.2021.201356.
- Guschinskaya, O., Dolgui, A., Guschinsky, N., Levin, G. (2008) A heuristic multi-start decomposition approach for optimal design of serial machining lines. *European Journal of Operational Research*, 189 (3): 902–913.
- Haddou Benderbal, H, Benyoucef L. (2019). Machine layout design problem under product family evolution in reconfigurable manufacturing environment: a two phase-based AMOSA approach. *The International Journal of Advanced Manufacturing Technology*, 104 (1-4):375–389.
- Hitomi, K. (1996). *Manufacturing Systems Engineering*, Taylor & Francis, London
- Ho, W., & Ji, P. (2010). Integrated component scheduling models for chips hooter machines, *International Journal of Production Economics*, 123: 31–41
- Khettabi, I., Benyoucef, L., & Boutiche, M. A. (2021). Sustainable reconfigurable manufacturing system design using adapted multi-objective evolutionary-based approaches. *The International Journal of Advanced Manufacturing Technology*, 115(11): 3741–3759.
- Khezri, A., Benderbal, H. H., & Benyoucef, L. (2021). Towards a sustainable reconfigurable manufacturing system (SRMS): multi-objective based approaches for process plan generation problem. *International Journal of Production Research*, 59(15): 4533–4558.
- Koren, Y, Heisel U, Jovane F, Moriwaki T, Pritschow G, Ulsoy G, Van Brussel H. (1999). *Reconfigurable Manufacturing Systems*. *CIRP Annals-Manufacturing Technology*, 48(2):527–540.
- Koren, Y, Wang W, Gu X. (2017). Value creation through design for scalability of reconfigurable manufacturing systems. *International Journal of Production Research* 55(5):1227–1242.
- Li, X., Nassehi A., Bogdan I. Epureanu B. I. (2019). Degradation-aware decision making in reconfigurable manufacturing systems, *CIRP Annals-Manufacturing Technology*, 68(1): 431–434.
- Massimi, E., Khezri, A., Benderbal, H. H., & Benyoucef, L. (2020). A heuristic-based non-linear mixed integer approach for optimizing modularity and integrability in a sustainable reconfigurable manufacturing environment. *The International Journal of Advanced Manufacturing Technology*, 108(7): 1997–2020.
- Moghaddam, S. K, Houshmand M., Valilai O. F. (2017). Configuration design in scalable reconfigurable

- manufacturing systems (RMS): a case of single-product flow line (SPFL). *International Journal of Production Research*, 56 (11): 3932–3954.
- Pansare, R., Yadav, G. and Nagare, M.R. (2023), "Reconfigurable manufacturing system: a systematic review, meta-analysis and future research directions", *Journal of Engineering, Design and Technology*, 21 (1): 228–265. <https://doi.org/10.1108/JEDT-05-2021-0231>.
- Pansare, R., Yadav, G. and Nagare, M.R. (2022). Reconfigurable manufacturing system: a systematic bibliometric analysis and future research agenda", *Journal of Manufacturing Technology Management*, 33 (3): 543–574. <https://doi.org/10.1108/JMTM-04-2021-0137>.
- Singh, P.P., Madan, J., & Singh, H. (2021). Composite performance metric for product flow configuration selection of reconfigurable manufacturing system (RMS). *International Journal of Production Research*, 59(13): 3996–4016.
- Singh, R. K., Khilwani N., and Tiwari M. K. (2007). Justification for the selection of a reconfigurable manufacturing system: a fuzzy analytical hierarchy based approach. *International Journal of Production Research*, 45(14):3165–3190.
- Sun, D.-S., Lee, T.E., Kim, K.-H. (2005). Component allocation and feeder arrangement for a dual-gantry multi-head surface mounting placement tool, *International Journal of Production Economics*, 95: 245–264.
- Wang, G., Shang X., Yan Y., Allen J. K., Mistree, F. (2018). A tree-based decision method for the configuration design of reconfigurable machine tools. *Journal of Manufacturing Systems*, 49: 143–162.
- Xia Q., Etienne A., Dantan J.-Y., Siadat A. (2018). Reconfigurable machining process planning for part variety in new manufacturing paradigms: Definitions, models and framework, *Computers and Industrial Engineering*, 115: 206–219.
- Yelles-Chaouche, A.R, Gurevsky E, Brahimi N, Dolgui A. (2020). Reconfigurable manufacturing systems from an optimisation perspective: a focused review of literature. *International Journal of Production Research*, 59(21): 6400–6418.
- Youssef, A. M., ElMaraghy H. A. (2006). Modelling and optimization of multiple-aspect RMS configurations. *International Journal of Production Research*, 46(22): 4929–4958.
- Szadkowski, J. (1971). An approach to machining process optimization. *International Journal of Production Research*, 9(3): 371–376.
- Szadkowski, J. (1997). Critical path concept for multi-tool cutting processes optimization. In *Manufacturing Modeling, Management and Control (MIM'97)*, IFAC symposium (pp. 393–398). Vienna, Austria: Elsevier.