



**HAL**  
open science

# A linear Algorithm For The Eternal Feedback Vertex Set on Interval Graphs\*

Nour Dyab, Mohammed Lalou, Hamamache Kheddouci

► **To cite this version:**

Nour Dyab, Mohammed Lalou, Hamamache Kheddouci. A linear Algorithm For The Eternal Feedback Vertex Set on Interval Graphs\*. International Conference on Control, Decision and Information Technologies, Jul 2023, Rom, Italy. hal-04197633

**HAL Id: hal-04197633**

**<https://hal.science/hal-04197633v1>**

Submitted on 8 Sep 2023

**HAL** is a multi-disciplinary open access archive for the deposit and dissemination of scientific research documents, whether they are published or not. The documents may come from teaching and research institutions in France or abroad, or from public or private research centers.

L'archive ouverte pluridisciplinaire **HAL**, est destinée au dépôt et à la diffusion de documents scientifiques de niveau recherche, publiés ou non, émanant des établissements d'enseignement et de recherche français ou étrangers, des laboratoires publics ou privés.

# A linear Algorithm For The Eternal Feedback Vertex Set on Interval Graphs\*

Nour DYAB<sup>1</sup> and Mohammed LALOU<sup>1,2</sup> and Hamamache KHEDDOUCI<sup>1</sup>

**Abstract**—The *Eternal Feedback Vertex Set* problem is a new model of protecting graphs using mobile guards, which is usually modeled using a two-players game; a defender and an attacker. This model is based on an initial selection, by the defender, of a dominating feedback vertex set  $F$  used to hold guards, where a guard can be moved to a neighboring attacked vertex of  $F$ . The resulting guard configuration must be also a dominating feedback vertex set. In this paper, we prove that the eternal feedback vertex number  $F^\infty(G)$ , which is the minimal cardinality of  $F$ , on an interval graph  $G$  depends on the number of cliques in  $G$ . Then, we develop a linear algorithm for finding the eternal feedback vertex set on  $G$ .

## I. INTRODUCTION

Graph protection using mobile guards has received a lot of attention in the literature. It has been considered in different forms, including eternal dominating set [1], eternal independent set [3], and Eternal Vertex Cover set [2]. This problem consists in defending the vertices of a graph  $G$  against an infinite number of attacks using defence units, called guards, placed on some vertices of  $G$ . Thus, it can be modeled as a game with two players. The first player, called the defender, has a role to defend each attack by the other player, called the attacker. First, the defender chooses a set of vertices  $S_1$  and put a guard on each vertex of  $S_1$ . Then, at turn  $i$ , the attacker must choose a vertex  $r_i \in V \setminus S_{i-1}$ , called the attacked vertex, that the defender must defend by moving a guard to  $r_i$  from one of its neighboring  $v_i \in S_{i-1}$ . The defender wins the game if he defends all the attacks, otherwise the attacker wins.

Let  $\{S_i\}$ ,  $S_i \subseteq V$ ,  $i \geq 1$  be the collection of subsets of vertices throughout the game, with one guard located on each vertex. Consider the *Eternal Feedback Vertex Set (EFVS)* version, the collection of set  $\{S_i\}$  must be a dominating feedback vertex set of  $G$  at each turn, i.e.  $S_1 = F_1$  is a feedback dominating set, and  $F_i = F_{i-1} \setminus \{v_i\} \cup \{r_i\}$  is also a dominating feedback vertex set of  $G$ . A feedback dominating set of  $G$  is a subset of vertices that satisfies both the dominating and feedback properties.

Hereafter, we denote *EFVS* the set of vertices initially chosen by the defender to hold guards for a winning strategy. Also, we denote the *Eternal Feedback Vertex number*,  $F^\infty(G)$ , the minimum number of guards that can be used

by the defender to win the game ;  $F^\infty(G) = \min\{|S|, S \in EFVS\}$ .

The eternal feedback vertex set of  $G$  is a particular case of the eternal dominating set problem, which is the graph protection model where guards configurations are dominating sets (in all turns) [1]. In fact, by definition an *EFVS*, besides it is a feedback set, it is also a dominating set of  $G$ .

We focus in this work on the case where the defender protects vertices by moving only one guard at each turn. The case where moving more than one guard is allowed is known as the *m-Eternal Feedback Vertex Sets* version.

Consider the graph  $G = (V, E)$  in *Figure 1*, where  $V = \{v_1, v_2, v_3, v_4, v_5, v_6\}$  and  $|E| = 8$ . We have  $\{v_3\}$  is a feedback vertex set of  $G$ , while the smallest dominating set of  $G$  must contain at least two vertices. Thus, we start our game with at least two guards. Without loss of generality, let  $F = \{v_3, v_6\}$  be the initial set chosen by the defender to hold the guards. Assume that vertex  $v_1$  is attacked, the defender must remove the guard from  $v_3$  to  $v_1$ , which results in a cycle  $v_3v_4v_5$ . Thus, the new guard configuration,  $F' = \{v_1, v_6\}$ , is a non dominating feedback vertex set and hence, the defender lose the game (see *Figure 1a*). Now, we assume that the defender chooses to start the game with three guards, without loss of generality, let  $F = \{v_1, v_4, v_6\}$  be the set of vertices that hold the guards. At the first turn, we suppose that the attacker attacks  $v_2$ , and then the defender moves the guard from  $v_1$  to  $v_2$ . The new guard configuration,  $F_1 = \{v_2, v_4, v_6\}$ , is a dominating feedback vertex set, see *Figure 1b*. One can see that, through infinite turns, a guard on a shaded vertex can move to its neighbor, if it is attacked, and the new guard configuration is isomorphic to the initial configuration.

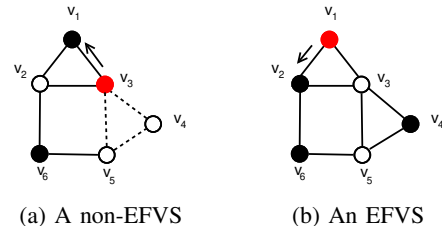

Fig. 1: The guards are placed on the black shaded vertices, and the red nodes are the positions of guards before moving.

Many works dealing with graph eternal sets have been presented in the literature, and a nice review of different

\*This work was not supported by any organization  
<sup>1</sup>Université Claude Bernard Lyon 1, UFR-Informatique, Lab LIRIS, 43 bd du 11 Novembre 1918, F-69622, 69100, Villeurbanne, France {nour.dyab, hamamache.kheddouci}@univ-lyon1.fr  
<sup>2</sup>Université de Bourgogne, UFR-Science et Technique, Lab LIB, 21000, Dijon, France mohammed.lalou@u-bourgogne.fr

obtained results can be found in [6] [7] [4].

Recently, Rinenberg *et.al* [8] have presented a linear algorithm for the *eternal dominating problem* on interval graphs. Also, they proved that the eternal dominating and the clique-connected cover numbers coincide for this class of graph. In this paper, we develop an algorithm, using graph partitioning, to compute the eternal feedback vertex number for interval graphs. Note that the classical feedback problem is known to be polynomial-time solvable on interval graphs [9], and a polynomial-time algorithm has been presented in [10].

In this work, we consider the problem on the interval class of graph. We prove in a first time the Eternal Feedback Vertex number,  $F^\infty(G)$ , on this class of graph and then we develop an algorithm for computing it. The rest of the paper is organized as follows. In *Section II*, we state different definitions and notations we use in throughout the paper, as well as a decomposition approach of interval graphs into disjoint complete subgraphs. We compute the eternal feedback vertex number of interval graphs in *Sections III*. Then, we develop, in *Sections IV*, a linear algorithm to solve the EFVS problem on this class of graphs. We close up the paper with a conclusion

## II. DEFINITIONS AND NOTATIONS

Throughout this paper, all graphs are considered finite, without loops, and without multiple edges. Let  $G = (V, E)$  be a graph with the set of vertices  $V(G)$  and set of edges  $E$ . For each vertex  $v \in V(G)$ , let  $N(v)$  (resp.  $N[v]$ ) represents the open neighborhood set (resp. closed neighborhood set) of  $v$ . A subset  $S \subseteq V$  is a *clique* if it induces a complete subgraph, *i.e.* a clique of  $G$  is a set of pairwise adjacent vertices of  $G$ , and it is *maximal* if it is not contained in another clique. A *clique partitioning* of graph  $G$  is a decomposition of  $G$  into maximal cliques by edge deletion. We denote  $G[S]$  the subgraph of  $G$  induced by  $S \subset V(G)$ .  $S$  is said to be *dominating set* of  $G$  if  $\bigcup_{s \in S} N[v] = V$ , and the

*dominating number*  $\gamma(G)$  is the size of a smallest dominating set of  $G$ .  $S$  is a *Feedback Vertex Set* (FVS) if its removal induced a forest. The *feedback vertex number*  $F(G)$  is the size of the smallest FVS of  $G$ .

A *cycle graph*  $C_n$  is a chain of edges that begins and end at the same point. A graph  $G$  is a *complete graph*, denoted  $K_n$ , if each pair of graph vertices are adjacent.

An interval graph is a graph in which each vertex can be mapped into an interval in the real line. Let  $G = (V, E)$  with  $V = \{v_1, \dots, v_n\}$  be an interval graph, and let  $I_i = [b_i, e_i]$ , where  $b_i$  represents the beginning point and  $e_i$  represents the ending point of the interval  $I_i$ , be a closed interval assigned to the vertex  $v_i \in V$  and  $\Gamma = \{I_1, I_2, \dots, I_n\}$  be the interval representation of  $G$ . If the intersection between  $I_i$  and  $I_j$  is not empty, for all  $i \neq j$ , then  $v_i$  is adjacent to  $v_j$  in  $G$ , *i.e.*  $v_i v_j \in E$  if and only if  $I_i \cap I_j \neq \emptyset$ , (see *Figure 2*).

Interval graphs play an important role in many real-world applications including biology, genetics, traffic sequencing and task scheduling [[11], [12], [13]]. Such graphs have

engaged the interest of many researchers in many domains, as they can be used to model many real-world problems.

For more illustration on the properties that make them as a powerful modeling tool, we invite the reader to [[14], [15]].

### A. Interval Graph Clique Partition

Let state the following adapted graph partitioning approach needed for the rest of the paper, and which is a slightly different method from the one presented in [8].

Let  $G = (V, E)$  be an interval graph, with  $V = \{v_1, \dots, v_n\}$ , constructed by a family of intervals  $\Gamma = \{I_1, I_2, \dots, I_n\}$ , by associating a vertex  $v_i \in V$  to each interval  $I_i$ , for  $1 \leq i \leq n$ . Let  $\beta(\Gamma)$  be an increasing order of interval in  $\Gamma$  according to their endpoints, *i.e.*  $e_1 < e_2 < \dots < e_n$ . We partition  $\Gamma$  on a set of subset of intervals  $\Gamma_1, \Gamma_2, \dots, \Gamma_p$ , each corresponding to a clique of  $G$ , as follows.

Let  $C_1 = I_1$ , the first interval in  $\Gamma$  according to  $\beta(\Gamma)$ . We define  $\Gamma_1 = C_1 \cup \{I_j \in \Gamma | I_j \cap C_1 \neq \emptyset\}$ .  $\Gamma_1$  contains, besides  $I_1$  all intervals that intersect  $C_1$ . Similarly, we define  $C_{i+1}$  as the first interval in  $\Gamma \setminus \bigcup_j \Gamma_j$  according to  $\beta(\Gamma)$ , and so  $\Gamma_{i+1} = C_{i+1} \cup \{I_j \in \Gamma \setminus \bigcup_j \Gamma_j | I_j \cap C_{i+1} \neq \emptyset\}$  (see *Figure 2*).

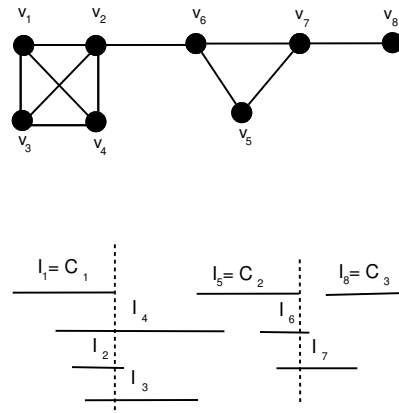

Fig. 2: An interval graph  $G$  and its interval representation  $\Gamma$ . We have,  $C_1 = I_1$ ,  $C_2 = I_5$  and  $C_3 = I_8$ , and hence  $\Gamma_1 = \{I_1, I_2, I_3, I_4\}$ ,  $\Gamma_2 = \{I_5, I_6, I_7\}$ ,  $\Gamma_3 = \{I_8\}$ .

The subgraphs  $G_1, \dots, G_p$  induced by the vertices of  $G$  associated to the intervals of  $\Gamma_1, \dots, \Gamma_p$  are complete graphs (cliques).

## III. ETERNAL FEEDBACK VERTEX NUMBER $F^\infty$ ON INTERVAL GRAPHS

Before computing the EFVS number of an interval graph, let first present the following needed result.

*Lemma 1:* Let  $G = K_n$  be a complete graph, where  $n \geq 3$ . We have:

$$F^\infty(K_n) = F(K_n) = n - 2.$$

*Proof:*

Given a complete graph  $G = K_n$ , where  $n \geq 3$ , each triplet of vertices in  $K_n$  forms a cycle, and thus we

must delete at least  $n - 2$  vertices to get a forest. Hence,  $F^\infty(K_n) \geq F(K_n) = n - 2$ . The graph obtained from  $K_n$  after deleting  $n - 2$  vertices is an edge (acyclic graph), and hence  $F^\infty(K_n) = F(K_n) = n - 2$ . ■

**Theorem 2:** Let  $G = (V, E)$  be an interval graph, and let  $G_1, \dots, G_p$  be the clique decomposition of  $G$ , then, we have:

$$F^\infty(G) = \sum_{n_j \geq 3} n_j - 2 + \sum_{n_j \leq 2} 1$$

where  $n_j$  denotes the number of vertices of  $G_j$ , for all  $j \geq 1$ .

*Proof:*

Let  $G$  be an interval graph constructed by a family of intervals,  $\Gamma = \{I_1, I_2, \dots, I_n\}$ , by associating a vertex  $v_i$  to each interval  $I_i = [b_i, e_i]$ , for  $1 \leq i \leq n$ . We partition  $G$  into  $p$  disjoint complete subgraphs, say  $G_1, G_2, \dots, G_p$ , using the method described in Section II-A. And let denote  $n_j$  the number of vertices of  $G_j$  induced by the vertices associated to the intervals in  $\Gamma_j$ , for all  $1 \leq j \leq p$ . From Lemma 1, we have each complete subgraph  $G_j$ , where  $n_j \geq 3$ , can be defended by  $n_j - 2$  guards, i.e.  $F^\infty(G_j) = n_j - 2$  if  $n_j > 3$ . Otherwise, if  $n_j \leq 2$ , we have  $G_j$  is either an edge or an isolated vertex, and in both cases  $F^\infty(G_j) = 1$ . So as a defender, for a winning strategy, we can place  $\sum_{n_j \geq 3} n_j - 2 + \sum_{n_j \leq 2} 1$  guards on  $G$ , and hence  $F^\infty(G) \leq \sum_{n_j \geq 3} n_j - 2 + \sum_{n_j \leq 2} 1$ .

Now to prove the equality, we prove that if the defender uses less than  $\sum_{n_j \geq 3} n_j - 2 + \sum_{n_j \leq 2} 1$  guards, for all  $1 \leq j \leq p$ , he will lose the game. We assume that the defender place less than  $\sum_{n_j \geq 3} n_j - 2 + \sum_{n_j \leq 2} 1$  guards on the vertices of  $G$ . One can see that, in this case, at least there is two subgraphs, say  $G_j$  and  $G_{j+1}$ , are protected by a common guard. This is the case of  $v_4$  in Figure 3a. We have four possible cases according to the number of vertices of each subgraph.

First, we suppose that  $n_j \geq 3$  and  $n_{j+1} \geq 3$ , and so there is a cycle either in  $G_j$  or in  $G_{j+1}$ , which leads to a contradiction (see Figure 3a). If we assume that  $n_j \geq 3$  and  $n_{j+1} \leq 2$ , which is the case of  $G_j[\{v_5, v_6, v_7\}]$  and  $G_{j+1}[\{v_8\}]$  of Figure 3b, then a cycle is obtained in  $G_j$  at the turn in which a guard must move from  $G_j$  to  $G_{j+1}$ , since  $G_j$  at this turn contains at most  $n_j - 3$  guards (a contradiction with Lemma 1). Now, suppose that  $n_j, n_{j+1} \leq 2$ , and let start with the case where  $n_j = 2$  and  $n_{j+1} = 1$  (see Figure 3c). According to our assumption, we have the vertices of the two subgraphs,  $G_j$  and  $G_{j+1}$ , holds at most one guard, and so there is a contradiction since the subgraph induced by  $G_j \cup G_{j+1}$  is a path with three vertices (at the turn where the guard is placed on the first vertex, the last vertex is not protected by any guard). Finally, in the case where  $n_j = n_{j+1} = 2$ , the subgraph induced by  $G_j \cup G_{j+1}$  is a path with four vertices (see Figure 3d), and defended by at most one guard (a contradiction). Therefore,  $F^\infty(G) = \sum_{n_j \geq 3} n_j - 2 + \sum_{n_j \leq 2} 1$ ,

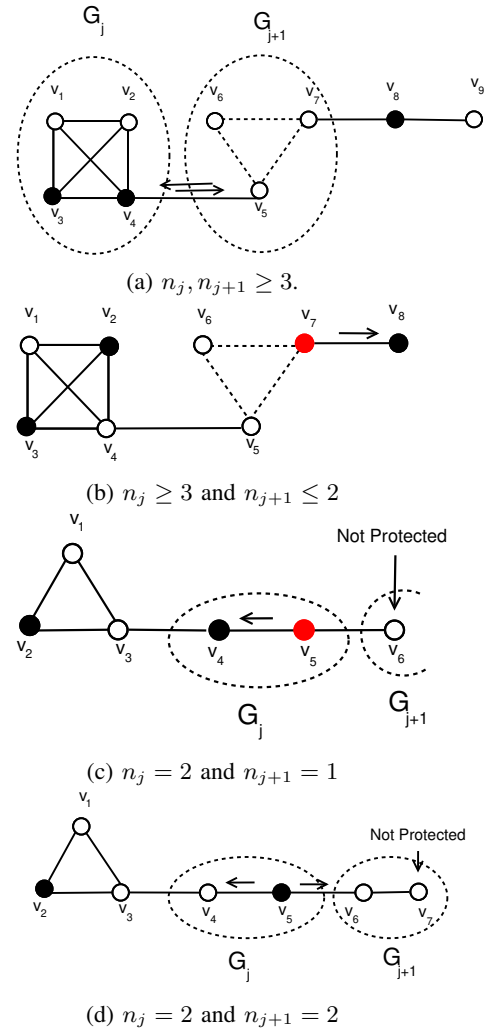

Fig. 3: The guards are placed on the black shaded vertices, and the red nodes are the positions of guards before moving.

where  $n_j$  presents the number of vertices of  $G_j$ , for all  $j \geq 1$ . ■

#### IV. ALGORITHM FOR FINDING EFVS ON INTERVAL GRAPHS

Given an interval graph  $G = (V, E)$ , a linear algorithm for finding the EFVS on  $G$  can be developed as follows:

One can easily see that Algorithm 1 runs in  $O(n)$ . Also, from Lemma 1 we have the set  $F$  returned by the algorithm is an initial choice for the defender in a winning game, i.e.  $F$  is a dominating feedback set which can hold the guards in a winning strategy, and which is minimal as removing any vertex from  $F$  results in either a cycle or a non-protected vertex.

Considering the interval graph  $G = (V, E)$  in Figure 4. According to the decomposition mentioned in Section II-A, we have  $\Gamma_1 = \{I_1, I_2, I_3, I_4, I_5\}$ ,  $\Gamma_2 = \{I_6, I_7\}$ ,  $\Gamma_3 = \{I_8, I_9\}$ , and  $\Gamma_4 = \{I_{10}, I_{11}, I_{12}\}$ . Therefore,  $G_1 = G[\{v_1, v_2, v_3, v_4, v_5\}]$ ,  $G_2 = G[\{v_6, v_7\}]$ ,  $G_3 = G[\{v_8, v_9\}]$  and  $G_4 = G[\{v_{10}, v_{11}, v_{12}\}]$  (see Figure 5). Hence, for

---

**Algorithm 1:** Algorithm for the EFVS problem on interval graphs

---

1 **Input:** an interval graph  $G = (V, E)$   
2 **Output:** an EFVS and the EFV number of  $G$   
3 Partition  $G$  using the decomposition mentioned in Section II-A, and let  $G_i = (V_i, E_i)$ ,  $1 \leq i \leq p$  be the set of cliques, where  $V_i = \{v_1^i, \dots, v_{n_i}^i\}$ ,  $n_i$  is the number of vertices of  $G_i$ .  
4  $F \leftarrow \phi$  and  $F^\infty(G) \leftarrow 0$   
5 **for**  $i=1, \dots, p$  **do**  
6     **if**  $n_i \geq 3$  **then**  
7          $F \leftarrow F \cup \{v_1^i, \dots, v_{n_i-2}^i\}$   
8          $F^\infty(G) \leftarrow F^\infty(G) + n_i - 2$   
9     **else**  
10          $F \leftarrow F \cup \{v_1^i\}$   
11          $F^\infty(G) \leftarrow F^\infty(G) + 1$   
12     **end**  
13 **end**  
14 **return**  $F$  and  $F^\infty(G)$

---

$1 \leq j \leq 4$ , we have:

$$F^\infty(G) = 3 + 1 + 1 + 1 = 6.$$

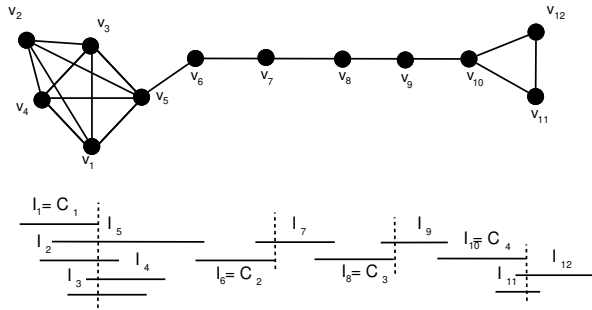

Fig. 4: An interval model (below) of an interval graph  $G$  (above).

Now, suppose that  $G$  is protected by less than 6 guards. Without loss of generality, let  $F_1 = \{v_1, v_3, v_5, v_8, v_{10}\}$  and the vertex  $v_6$  is attacked. The only possible guard moves, from  $v_5$  to  $v_6$ , will generate a cycle  $v_2v_4v_5$  (Figure 6).

### CONCLUSION

In this paper, we proposed and studied a new model of graph protection using mobile guards, namely the *Eternal Feedback Vertex Set*. This problem is hard even when considered on relatively simple classes of graphs. We developed a linear algorithm to solve it on interval graphs. The algorithm is based on a graph partitioning method as a preprocessing step, and then select the number of guards of each partition independently. The algorithm may be generalized for the EFVS problem where more than one move are possible by turn.

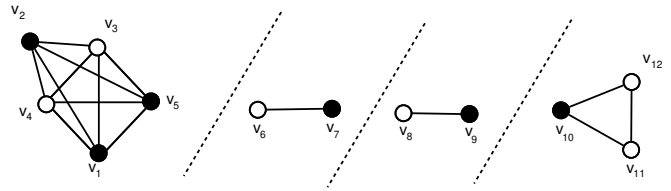

Fig. 5: The decomposition of graph  $G$ , the guards are on the shaded vertices.

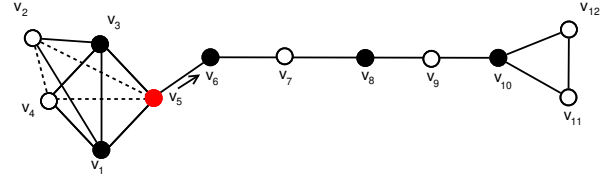

Fig. 6: Non-EFVS of  $G$ , the guards are on the black shaded vertices and the red node present the position of guard before moving.

For future work, It is worthy to consider the problem on more general classes of graphs, particularly those usually used for modeling games, such as  $k$ -dimensional graphs. As well, considering the general case where guards can be moved for more than one hop.

### REFERENCES

- [1] A. P. Burger, E. J. Cockayne, W.R. Grundlingh, C. Mynhardt, J.H van Vuuren, W. Winterbach, Infinite order domination in graphs, *Journal of Combinatorial Mathematics and Combinatorial Computing*, 50, 179-194 (2004).
- [2] W. Klostermeyer, An eternal vertex cover problem, *Combinatorial Mathematics and Combinatorial Computing*, 85, 79-95 (2013).
- [3] B.L. Hartnell, C. Mynhardt, Independent protection in graphs, *Discrete Mathematics*, 335, 100-109 (2014).
- [4] W. F. Klostermeyer, & C. M. Mynhardt. Protecting a graph with mobile guards, *Applicable Analysis and Discrete Mathematics*, 10(1), 1-29 (2016).
- [5] N. Dyab, M. Lalou, H. Kheddouci, Eernal feedback vertex sets: A new graph protection model using guards, *Discussiones Mathematicae Graph Theory* (Under review) (2022).
- [6] W.F. Klostermeyer, M. Lawrence, G. MacGillivray, Dynamic dominating sets: the eviction model for eternal domination, *Journal of Combinatorial Mathematics and Combinatorial Computing*, 97, 247-269 (2016).
- [7] W.F. Klostermeyer, C. Mynhardt, Protecting a graph with mobile guards, *Applicable Analysis and Discrete Mathematics*, 10 (1), 1-29 (2016).
- [8] M. Rinenberg, F.J Soullignac, The eternal dominating set problem for interval graphs, *Information Processing Letters*, 146, 27-29 (2019).
- [9] C.L Lu, C.Y Tang, A linear-time algorithm for the weighted feedback vertex problem on interval graphs, *Information Processing Letters*, 61 (2), 107-111 (1997).
- [10] C. Papadopoulos, S. Tzimas, Polynomial-time algorithms for the subset feedback vertex set problem on interval graphs and permutation graphs, *Discrete Applied Mathematics*, 258, 204-221 (2019).
- [11] S. Benzer, On the topology of the genetic fine structure, *Proceedings of the National Academy of Sciences of the United States of America*, 45 (11), 1607 (1959).
- [12] K.E. Stoffers, Scheduling of traffic lights-a new approach, *Transportation Research/UK*, 2 (3), (1967).
- [13] F.S Roberts, *Discrete mathematical models, with applications to social, biological, and environmental problems*, Prentice-Hall, (1976).

- [14] M.C. Golumbic, Algorithmic graph theory and perfect graphs, Elsevier, (2014).
- [15] L. Ibarra, The clique-separator graph for chordal graphs, *Discrete Applied Mathematics*, 157(8), 1737–1749 (2009).