



HAL
open science

Rigidity of min-max minimal disks in 3-balls with non-negative Ricci curvature

Laurent Mazet, Abraão Mendes

► **To cite this version:**

Laurent Mazet, Abraão Mendes. Rigidity of min-max minimal disks in 3-balls with non-negative Ricci curvature. 2023. hal-04157042v2

HAL Id: hal-04157042

<https://hal.science/hal-04157042v2>

Preprint submitted on 11 Jul 2023

HAL is a multi-disciplinary open access archive for the deposit and dissemination of scientific research documents, whether they are published or not. The documents may come from teaching and research institutions in France or abroad, or from public or private research centers.

L'archive ouverte pluridisciplinaire **HAL**, est destinée au dépôt et à la diffusion de documents scientifiques de niveau recherche, publiés ou non, émanant des établissements d'enseignement et de recherche français ou étrangers, des laboratoires publics ou privés.

RIGIDITY OF MIN-MAX MINIMAL DISKS IN 3-BALLS WITH NON-NEGATIVE RICCI CURVATURE

LAURENT MAZET AND ABRAÃO MENDES

ABSTRACT. In this paper we prove a rigidity statement for free boundary minimal surfaces produced via min-max methods. More precisely, we prove that for any Riemannian metric g on the 3-ball B with non-negative Ricci curvature and $\Pi_{\partial B} \geq g|_{\partial B}$, there exists a free boundary minimal disk Δ of least area among all free boundary minimal disks in (B, g) . Moreover, the area of any such Δ equals to the width of (B, g) , Δ has index one, and the length of $\partial\Delta$ is bounded from above by 2π . Furthermore, the length of $\partial\Delta$ equals to 2π if and only if (B, g) is isometric to the Euclidean unit ball. This is related to a rigidity result obtained by F.C. Marques and A. Neves in the closed case. The proof uses a rigidity statement concerning half-balls with non-negative Ricci curvature which is true in any dimension.

1. INTRODUCTION

In Riemannian geometry, a classical question consists in controlling the size of a Riemannian manifold in terms of its curvature tensor. For example, Bonnet-Myers theorem gives an upper bound on the diameter of a Riemannian manifold under a lower bound on its Ricci curvature. The proof of this result is based on the interplay between the Ricci curvature and the minimization property of some geodesics.

Other notions for the size of a manifold can be considered. For example, for a nontrivial homology class, one could think of the minimal volume of elements in this class. For closed curves this leads to the notion of systole and gives estimate for the injectivity radius, see for example Klingenberg's estimate or Toponogov theorem.

For submanifolds of dimension at least 2, stable minimal submanifolds appear as realizations of the minimum of the volume in the homology class. Hence estimating the volume of such stable, or even area-minimizing, minimal submanifolds is a natural question. For example, H. Bray, S. Brendle and A. Neves [4] have proved that an area-minimizing 2-sphere in a 3-manifold whose scalar curvature is at least 2 has area at most 4π . Moreover, in case of equality, the universal cover of the ambient manifold is isometric to the standard cylinder $\mathbb{S}^2 \times \mathbb{R}$.

Another concept to measure the size of a Riemannian manifold is a min-max quantity W called the width introduced by F. Almgren to produce minimal hypersurfaces when the topology of the ambient manifold does not allow the minimization approach (see also M. Gromov [16]). In this situation, the minimal hypersurfaces that appear are in general neither area-minimizing nor stable. For example, in the case of a Riemannian 3-sphere, L. Simon and F. Smith [28] defined a notion of width that allowed them to produce a minimal 2-sphere. In a seminal work, F.C. Marques and A. Neves [24] initiated the study of the Morse index of minimal hypersurfaces produced by min-max methods. Among other things, they proved the following rigidity result:

Theorem 1.1 ([24, Theorem 4.9]). *Let g be a Riemannian metric on the 3-sphere \mathbb{S}^3 , with scalar curvature $R \geq 6$, such that there are no stable embedded minimal spheres in (\mathbb{S}^3, g) (in*

1991 *Mathematics Subject Classification.* 53A10, 53C24, 53C42.

L.M. was partially supported by the ANR-19-CE40-0014 grant. A.M. was partially supported by the National Council for Scientific and Technological Development – CNPq, Brazil (Grant 305710/2020-6) and the Fundação de Amparo à Pesquisa do Estado de Alagoas – FAPEAL, Brazil (Process E:60030.0000002254/2022). The authors were partially supported by the Coordenação de Aperfeiçoamento de Pessoal de Nível Superior – Brasil (CAPES-COFECUB 88887.143161/2017-0).

particular, if g has positive Ricci curvature). Then there is an embedded minimal sphere Σ in (\mathbb{S}^3, g) such that

$$|\Sigma| = \inf\{|S|; S \text{ is an embedded minimal sphere in } (\mathbb{S}^3, g)\}.$$

Moreover, any such Σ satisfies the following conditions:

- $|\Sigma| = W(\mathbb{S}^3, g)$ (the Simon-Smith width);
- Σ has index one;
- $|\Sigma| \leq 4\pi$.

Besides, the equality $|\Sigma| = 4\pi$ holds if and only if (\mathbb{S}^3, g) is isometric to the Euclidean unit sphere.

When the sectional curvature of (\mathbb{S}^3, g) is at most 1, the first author [25] proved that we have the reverse estimate: the width is at least 4π and the rigidity statement is also true in the equality case.

In the case of compact Riemannian manifold with boundary, the min-max approach has also been used to produce free boundary minimal hypersurfaces: minimal hypersurfaces that meet the boundary orthogonally (see [5, 22]). In this context, one could also expect some estimates of the width under some curvature assumptions. In this paper, we consider the case of a Riemannian 3-ball (B, g) . The Simon-Smith approach can be used to produce either a free boundary minimal disk or a minimal sphere under a convexity assumption on the boundary (see M. Grüter and J. Jost [17, 20] and precise definitions below). Besides, if the Ricci curvature is non-negative, the minimal sphere can be excluded. Under these assumptions, the minimal disk should have index one and computation does not lead to an estimate of the area of the disk but of its perimeter. Actually, the second author [26, Theorem 1.3] proved

Theorem 1.2. *Let (M^3, g) be a compact orientable Riemannian 3-manifold with boundary with non-negative Ricci curvature and such that $\Pi_{\partial M} \geq g_{\partial M}$. If Σ is an orientable free boundary minimal surface in M of index one, then its perimeter satisfies*

$$L(\partial\Sigma) \leq 2\pi(\mathbf{g} + \mathbf{k}),$$

where \mathbf{g} is the genus of Σ and \mathbf{k} the number of connected components of $\partial\Sigma$. Moreover, in case of equality,

- (1) Σ with its induced metric is isometric to the Euclidean unit disk;
- (2) $\partial\Sigma$ is a geodesic of ∂M ;
- (3) Σ is totally geodesic;
- (4) all sectional curvatures of M vanish on Σ .

Moreover, he was able to prove that, in the equality case and under some extra hypothesis, (M, g) is isometric to the Euclidean unit 3-ball. Let us remark that under the curvature assumptions on the Ricci tensor and $\Pi_{\partial M}$, (M^3, g) in the above theorem is diffeomorphic to the 3-ball (see the work of A. Fraser and M.M.-C. Li [12, Theorem 2.11]). One of the main results of the paper should be compared with Theorem 1.1; it makes the link between the min-max construction of free boundary minimal disks and Theorem 1.2. Moreover we are able to obtain the rigidity statement without any extra hypothesis.

Theorem 1.3. *Let g be a Riemannian metric on the 3-ball B with non-negative Ricci curvature and such that $\Pi_{\partial B} \geq g_{\partial B}$, where $\Pi_{\partial B}$ is the second fundamental form of ∂B in (B, g) with respect to the inward unit normal. Then there is a free boundary minimal disk Δ in (B, g) such that*

$$|\Delta| = \inf\{|D|; D \text{ is a free boundary minimal disk in } (B, g)\}.$$

Moreover, any such Δ satisfies the following conditions:

- $|\Delta| = W(B, g)$;
- Δ has index one;
- $L(\partial\Delta) \leq 2\pi$.

Besides, the equality $L(\partial\Delta) = 2\pi$ holds if and only if (B, g) is isometric to the Euclidean unit ball.

Actually, it would be interesting to have an estimate of the area of the free boundary minimal disk and then of the width $W(B, g)$. When the non-negativity of the Ricci curvature is replaced by the non-negativity of the sectional curvature, we are able to prove that Δ has area at most π . Actually, under this assumption, we can prove that $|\Sigma| \leq \frac{1}{2}L(\partial\Sigma)$ for any free boundary minimal surface Σ .

The proof of the rigidity statement is based on a characterization of the Euclidean unit half-ball $B_+^n = \{(x_1, \dots, x_n) \in \mathbb{R}^n \mid x_1^2 + \dots + x_n^2 \leq 1 \text{ and } x_n \geq 0\}$ which is true in any dimension (see Theorem 5.1 for a precise statement).

Theorem 1.4. *Let g be a Riemannian metric on B_+^n with non-negative Ricci curvature and such that the mean curvature of $\mathbb{S}^n \cap B_+^n$ is at least $n - 1$. We also assume that $B_+^n \cap \{x_n = 0\}$ is totally geodesic, isometric to the Euclidean unit $(n - 1)$ -ball and meets $\mathbb{S}^n \cap B_+^n$ orthogonally. Then (B_+^n, g) is isometric to the Euclidean B_+^n .*

The proof of the above result is based on ideas that appear in the work of R. Reilly [27] and also used by C. Xia [29].

Organization of the paper. In Subsection 2.1 we recall some important definitions for the context of free boundary minimal hypersurfaces. In Subsection 2.2 we introduce and prove the existence of the *nice foliation* associated with a free boundary minimal hypersurface of index at least one. In Subsection 2.3 we state and prove an independent result that furnishes a sharp area estimate for free boundary minimal hypersurfaces in terms of their perimeter when the ambient Riemannian manifold has non-negative sectional curvature and strictly convex boundary. As an application, if g in Theorem 1.3 has non-negative sectional curvature, then $|\Delta| \leq \pi$ and the equality holds if and only if (B, g) is isometric to the Euclidean unit ball. In Section 3 we recall some min-max constructions of free boundary minimal surfaces in Riemannian 3-manifolds with strictly convex boundary. There, we study two different cases: the first one applies to compact 3-manifolds with smooth boundary, this is called the *unconstrained case* (Subsection 3.1); the second deals with compact 3-manifolds with piecewise smooth boundary and, in this case, we want to prevent the min-max minimal surface to attach to a certain part of the boundary, this is called the *constrained case* (Subsection 3.2). In Section 4 we explain how to control the topology of the minimal surface obtained through the min-max constructions in the preceding section. Notice that a similar topological control has been also obtained very recently by G. Franz and M. Schulz [11]. In Section 5 we state and prove a rigidity result for the Euclidean half-ball (Theorem 5.1), which plays an important role in the proof of Theorem 1.3. Finally, in Section 6 we use all the machinery presented in the previous sections to prove Theorem 1.3. We end the paper with Appendix A where we construct some mean-convex foliation under some geometric hypotheses. We don't use this construction in the paper but it allows to apply the min-max theory in some more general situations.

Notations. Among other notations, we will use \mathcal{H}^2 to denote the 2-dimensional Hausdorff measure. If S is a k -submanifold of a Riemannian manifold, we will denote by $\mathbf{v}(S)$ the associated k -dimensional varifold.

Thanks. The authors would like to thank Martin Li for his answers about the min-max theory in the free boundary setting. They also thanks Robert Haslhofer for pointing us the reference [19].

2. PRELIMINARIES

2.1. Definitions. We say that M is an n -manifold with piecewise smooth boundary if it has local C^∞ -charts given by open subsets of $\mathbb{R}_+^2 \times \mathbb{R}^{n-2}$. The set of points in ∂M corresponding to $\{(0,0)\} \times \mathbb{R}^{n-2}$ by the charts is called the *corner* of M and denoted by $\mathcal{C}(M)$.

Let M be such an n -manifold with piecewise smooth boundary and Σ be an $(n-1)$ -manifold with boundary. We say that a smooth embedding $\phi : \Sigma \rightarrow M$ is *proper* if

$$\phi(\partial\Sigma) = \phi(\Sigma) \cap \partial M \subset \partial M \setminus \mathcal{C}(M).$$

If $\Sigma \subset M$ and ϕ is just the inclusion map, we say that Σ is a *properly embedded hypersurface* in M .

Let M be endowed with a Riemannian metric. If Σ is a properly embedded hypersurface and $\{F_t\}$ is a smooth family of proper embeddings of Σ in M with $F_0 = \text{id}$, one can compute the $(n-1)$ -volume of $F_t(\Sigma)$ (denoted by $|F_t(\Sigma)|$) and its derivative with respect to t at time $t=0$. We have

$$\frac{d}{dt}|F_t(\Sigma)|_{t=0} = - \int_{\Sigma} (X, \vec{H}) + \int_{\partial\Sigma} (X, \nu),$$

where $X = \frac{\partial}{\partial t} F_t|_{t=0}$ is the variation vector field, \vec{H} is the mean curvature vector of Σ in M and ν is the unit conormal to $\partial\Sigma$ in Σ . So Σ is critical for the $(n-1)$ -volume if its mean curvature vector vanishes and Σ meets ∂M orthogonally. We call such a hypersurface a *free boundary minimal hypersurface*. More generally, a properly embedded hypersurface that meets ∂M orthogonally is called a *free boundary hypersurface*.

Except at the corner, we denote by $\text{II}_{\partial M}$ the second fundamental form of the boundary of M with respect to the inward unit normal. If Σ is a free boundary minimal hypersurface, and assuming that Σ is two-sided and X is normal to Σ , one can compute the second derivative of the $(n-1)$ -volume functional:

$$(2.1) \quad \begin{aligned} \frac{d^2}{dt^2}|F_t(\Sigma)|_{t=0} &= \int_{\Sigma} -u(\Delta u + (\text{Ric}(N, N) + \|A\|^2)u) + \int_{\partial\Sigma} u(\partial_\nu u - \text{II}_{\partial M}(N, N)u) \\ &= \int_{\Sigma} \|\nabla u\|^2 - (\text{Ric}(N, N) + \|A\|^2)u^2 - \int_{\partial\Sigma} \text{II}_{\partial M}(N, N)u^2, \end{aligned}$$

where N is the unit normal to Σ , $u = (X, N)$, A is the Weingarten map on Σ , and Ric is the Ricci tensor of M . Our sign convention is that in which $\vec{H} = HN$, where $H = \text{tr } A$ is the mean curvature of Σ with respect to N . Denoting by $Q(u, u)$ the last line in (2.1), we obtain a quadratic form associated with the Jacobi operator L of Σ ,

$$Lu = -\Delta u - (\text{Ric}(N, N) + \|A\|^2)u.$$

The index of the quadratic form Q is called the *index* of Σ and it is given by the number of negative eigenvalues of L with a Robin type boundary condition:

$$\begin{cases} Lu = \lambda u & \text{on } \Sigma, \\ \partial_\nu u - \text{II}_{\partial M}(N, N)u = 0 & \text{on } \partial\Sigma. \end{cases}$$

2.2. The nice foliation. Let Σ be a free boundary minimal hypersurface in M . If Σ has index at least one, we are going to construct a foliation of a tubular neighborhood of Σ by free boundary hypersurfaces whose mean curvature vectors are nowhere vanishing and point away from Σ .

Near Σ , let us parametrize M by $\Sigma \times (-1, 1)$ with coordinates $(p, t) \in \Sigma \times (-1, 1)$ such that the variation vector field ∂_t is normal to Σ at $t=0$. If u is a function defined on Σ with small L^∞ -norm, we can consider its graph: the image of $X_u : p \in \Sigma \mapsto (p, u(p)) \in \Sigma \times (-1, 1) \subset M$. For such a function u , we denote by $H(u)(p)$ the mean curvature of $X_u(\Sigma)$ at $X_u(p)$ with respect to the unit normal that points in the same direction as ∂_t . We have the following result:

Lemma 2.1. *With the above notations, there is a smooth family $\{u_t\}_{t \in (-\varepsilon, \varepsilon)}$ of functions on Σ such that*

- $u_0 = 0$ and $\partial_t u_t > 0$;
- $H(u_t)$ is nowhere vanishing and has the same sign as t for $t \neq 0$;
- $X_{u_t}(\Sigma)$ is a free boundary hypersurface.

With $\{u_t\}_{t \in (-\varepsilon, \varepsilon)}$ as in the above Lemma, the family $\{X_{u_t}(\Sigma)\}_{t \in (-\varepsilon, \varepsilon)}$ gives a foliation of a neighborhood of Σ which we call the *nice foliation* associated with Σ .

Proof. Since Σ has index at least one, the first eigenvalue of the Jacobi operator is negative: there are $\lambda_1 < 0$ and ϕ_1 a positive solution to

$$\begin{cases} \Delta \phi_1 + (\text{Ric}(N, N) + \|A\|^2)\phi_1 + \lambda_1 \phi_1 = 0 & \text{on } \Sigma, \\ \partial_\nu \phi_1 - \Pi_{\partial M}(N, N)\phi_1 = 0 & \text{on } \partial\Sigma. \end{cases}$$

Let $V^{k, \alpha}$ denote the L^2 -orthogonal complement of ϕ_1 in $C^{k, \alpha}(\Sigma)$ and Π be the orthogonal projection onto $V^{k, \alpha}$. Let η denote the inward unit normal to ∂M . Then, for u a function on Σ and $p \in \partial\Sigma$, we define $\mathcal{N}(u)(p) = \det(dX_u(e_1), \dots, dX_u(e_{n-1}), \eta(X_u(p)))$, where (e_i) is a direct orthonormal basis of $T_p\Sigma$ (this does not depend on the choice of the basis). We then define the map

$$F : \begin{array}{ccc} \mathbb{R} \times V^{2, \alpha} & \longrightarrow & V^{0, \alpha} \times C^{1, \alpha}(\partial\Sigma), \\ (t, v) & \longmapsto & (\Pi(H(t\phi_1 + v)) + \lambda_1 v, \mathcal{N}(t\phi_1 + v)). \end{array}$$

Notice that $F(0, 0) = 0$. We want to apply the implicit function theorem to F . Standard calculations show that (see [1, Proposition 17])

$$D_v F(0, 0)(h) = (-\Pi(Lh) + \lambda_1 h, \partial_\nu h - \Pi_{\partial M}(N, N)h).$$

Let us see that $D_v F(0, 0)$ is invertible. In fact, if $D_v F(0, 0)(h) = 0$, we have

$$\int_\Sigma \phi_1 Lh = \int_\Sigma h L\phi_1 + \int_{\partial\Sigma} (-\phi_1 \partial_\nu h + h \partial_\nu \phi_1) = \lambda_1 \int_\Sigma h \phi_1 - \int_{\partial\Sigma} \phi_1 (\partial_\nu h - \Pi_{\partial M}(N, N)h) = 0.$$

Therefore $\Pi(L(h)) = L(h)$ and h is a first eigenfunction of L , and thus $h = 0$, since $h \in V^{2, \alpha}$ is orthogonal to ϕ_1 . Moreover, for $(f, g) \in V^{0, \alpha} \times C^{1, \alpha}(\partial\Sigma)$, one can find a solution $h \in V^{2, \alpha}$ such that $D_v F(0, 0)(h) = (f, g)$. Indeed, let us first assume that $g \in C^{2, \alpha}(\partial\Sigma)$ and consider β a function in $C^{2, \alpha}(\Sigma)$ such that $\partial_\nu \beta - \Pi_{\partial M}(N, N)\beta = g$ (for example, $\beta = 0$ and $\partial_\nu \beta = g$ on $\partial\Sigma$). By adding a multiple of ϕ_1 , we may assume that β is orthogonal to ϕ_1 . The function $\tilde{f} = f - \lambda_1 \beta + \Pi(L\beta)$ is then in $V^{0, \alpha}$. Thus the Fredholm alternative ensures the existence of a solution $u \in V^{2, \alpha}$ to the system

$$\begin{cases} -Lu + \lambda_1 u = \tilde{f} & \text{on } \Sigma, \\ \partial_\nu u - \Pi_{\partial M}(N, N)u = 0 & \text{on } \partial\Sigma. \end{cases}$$

The regularity of the solution comes from results given in [15]. Then the function $u + \beta$ solves $D_v F(0, 0)(u + \beta) = (f, g)$. When $g \in C^{1, \alpha}(\partial\Sigma)$, we find the solution by approximating g by functions in $C^{2, \alpha}(\partial\Sigma)$ and using Schauder type estimates.

Hence the differential is invertible and there is a family $(v_t)_{t \in (-\varepsilon, \varepsilon)}$ such that $F(t, v_t) = 0$ and $v_0 = 0$. In particular, $\partial_t v_t|_{t=0} = 0$. Then $u_t = t\phi_1 + v_t$ will satisfy the Lemma. In fact, the first item is satisfied and we notice that the graph of u_t has free boundary, thanks to the second coordinate of F , so the last item is also satisfied. Besides,

$$\partial_t H(u_t)|_{t=0} = -L\phi_1 = -\lambda_1 \phi_1.$$

Then, since $\lambda_1 < 0$ and $\phi_1 > 0$, $H(u_t)$ has the expected sign. \square

2.3. The area of free boundary minimal hypersurfaces. In the sequel, we will obtain an estimate for the perimeter of a free boundary minimal surface. For many reasons, it would be interesting to obtain an area estimate. In fact, when the sectional curvature is non-negative, we have such an estimate thanks to the following result:

Proposition 2.2. *Let (M, g) be a Riemannian n -manifold with smooth boundary. Assume that (M, g) has non-negative sectional curvature and $\Pi_{\partial M} \geq g|_{\partial M}$. If Σ is a compact free boundary minimal hypersurface in (M, g) , then*

$$(n-1)|\Sigma| \leq |\partial\Sigma|.$$

Proof. Let q be a point in ∂M and U a neighborhood of q in ∂M . Consider $F : U \times [0, T) \rightarrow M$ the map defined by $F(x, t) = \exp_x(t\eta(x))$, where $\eta(x)$ is the inward unit normal to ∂M . If s is less than the first focal time along the geodesic $t \mapsto F(q, t)$, then F is a local diffeomorphism from a neighborhood of (q, s) to a neighborhood of $p = F(q, s)$. On this neighborhood, we can then define a “distance” function d_q by $d_q(F(x, t)) = t$. Moreover, if $d_q(m) = t$, its Hessian $\bar{\nabla}^2 d_q$ at m is given by $-\Pi_{\{d_q=t\}}$, where the second fundamental form is computed with respect to the unit normal $\bar{\nabla} d_q$. By comparison with Euclidean space (see H. Karcher [21]), the curvature assumptions give that $\Pi_{\{d_q=t\}} \geq \frac{1}{1-t}g|_{\{d_q=t\}}$. This ensures that d_q , and s , are bounded from above by 1 and, for $\bar{f}_q = d_q^2 - 2d_q$, $\bar{\nabla}^2 \bar{f}_q \geq 2g$.

Let d be the distance function to ∂M . If $d(p)$ is realized by a geodesic between p and $q \in \partial M$ such that d_q is defined near p , then $d \leq d_q \leq 1$ and $d(p) = d_q(p)$; notice that $d \leq 1$ on all of M . Let us define $\bar{f} = d^2 - 2d$. Let Σ be a compact free boundary minimal hypersurface in M and consider f the restriction of \bar{f} to Σ . We are going to prove the following:

Claim. In the viscosity sense, $\Delta f \geq 2(n-1)$ (see [2, 7]).

Proof of the claim. For $p \in \Sigma$, let ϕ be a smooth function on a neighborhood of p in Σ such that $\phi \geq f$ and $\phi(p) = f(p)$. Let γ be a unit speed geodesic with $\gamma(0) = q \in \partial M$ and $\gamma(s) = p$ that realizes the distance to ∂M , i.e. $d(p) = s$. If s is less than the first focal time along γ , then $d \leq d_q \leq 1$ and $d(p) = d_q(p)$. Therefore $\phi \geq f \geq d_q^2 - 2d_q$ with equality at p . Hence $\Delta\phi(p) \geq \Delta(d_q^2 - 2d_q)(p) \geq 2(n-1)$, since Σ is minimal.

If s is the first focal time along γ , we will modify the metric g to obtain the result. To do so, we will construct a function u on M with compact support in a neighborhood of $\gamma(s/2)$ that does not contain p such that $u = 0$ and $\bar{\nabla} u = 0$ along γ and $\bar{\nabla}^2 u(\gamma(t)) = \alpha(t)\pi^*g$ for some non-negative function $\alpha(t)$ with $\alpha(s/2) > 0$, where π is the orthonormal projection onto the normal bundle of γ and $\pi^*g(a, b) = g(\pi(a), \pi(b))$. In fact, consider a local chart near $\gamma(s/2)$ with coordinates (x_1, \dots, x_n) in the open n -cube $\mathcal{C}_\delta = (s/2 - \delta, s/2 + \delta) \times (-\delta, \delta) \times \dots \times (-\delta, \delta)$ with $0 < \delta < s/2$ such that, in these coordinates, γ is the curve $t \mapsto (t, 0, \dots, 0)$ and the Riemannian metric g satisfies $g_{ij} = \delta_{ij}$ along γ . Let $\alpha(t)$ be a non-negative function with compact support in $(s/2 - \delta/2, s/2 + \delta/2)$ such that $\alpha(s/2) > 0$. Then we can define u by

$$u(x_1, \dots, x_n) = \alpha(x_1)\varphi(x_2, \dots, x_n)\frac{x_2^2 + \dots + x_n^2}{2}$$

in the coordinate neighborhood and $u = 0$ outside it, where φ is a non-negative function with compact support in $(-\delta, \delta)^{n-1}$ such that $\varphi = 1$ on $(-\delta/2, \delta/2)^{n-1}$. Notice that u has compact support in \mathcal{C}_δ . Now, let $g_\varepsilon = e^{2\varepsilon u}g$ for $\varepsilon > 0$. Along γ , the metrics g and g_ε coincide, γ is a geodesic for g_ε and the covariant derivatives $\frac{D}{dt}$ and $\frac{D_\varepsilon}{dt}$ are the same. Moreover, the curvature

tensor associated with g_ε satisfies

$$R_\varepsilon(\gamma'(t), X)\gamma'(t) = R(\gamma'(t), X)\gamma'(t) - \varepsilon\alpha(t)X$$

for any vector field X orthogonal to γ (see [3]).

For $0 < a \leq s$, let \mathcal{V}_a be the space of continuous and piecewise differentiable vector fields V along $\gamma|_{[0,a]}$ such that $V \perp \gamma'$ and $V(a) = 0$. For $V, W \in \mathcal{V}_a$, let us define

$$I_a^\varepsilon(V, W) = \int_0^a (V', W') - (R_\varepsilon(\gamma', V)\gamma', W) dt.$$

By the index theorem (see [9]), the index of I_a^ε is given by the number of $t \in (0, a)$ that is a focal time of γ , for the metric g_ε , each one counted with multiplicity. Notice that

$$I_a^\varepsilon(V, V) = I_a^0(V, V) + \varepsilon \int_0^a \alpha(t)|V|^2 dt \geq I_a^0(V, V).$$

Therefore, the index of I_a^ε is less than or equal to the index of I_a^0 . On the other hand, by assumption, the first focal time along γ is s , so I_a^0 is non-negative for $a \leq s$ (no time $t < s$ is a focal time). If s is a focal time of γ for the metric g_ε , there is a nonzero Jacobi field J along γ with $J'(0) = 0$ and $J(s) = 0$. Thus

$$0 = I_s^\varepsilon(J, J) = I_s^0(J, J) + \varepsilon \int_0^s \alpha(t)|J|^2 dt \geq \varepsilon \int_0^s \alpha(t)|J|^2 dt > 0,$$

which is a contradiction. So the first focal time along γ for the metric g_ε is strictly larger than s for $\varepsilon > 0$.

We notice that, for the metric g_ε , the distance function d^ε to ∂M satisfies $d^\varepsilon \geq d$ and $d^\varepsilon(p) = d(p)$, since we keep the length of γ . Bearing in mind that s is not a focal time for g_ε , there is a local distance function d_q^ε defined near p such that $d^\varepsilon \leq d_q^\varepsilon$ and $d^\varepsilon(p) = d_q^\varepsilon(p)$. The metric g_ε has sectional curvature bounded from below by some $-c_\varepsilon^2$ with $c_\varepsilon > 0$ and $c_\varepsilon \rightarrow 0$ as $\varepsilon \rightarrow 0$. By comparison with the hyperbolic space [21], we have

$$\overline{\nabla}^2 d_q^\varepsilon(p) \leq -c_\varepsilon \frac{(1+c_\varepsilon) + (1-c_\varepsilon)e^{2c_\varepsilon s}}{(1+c_\varepsilon) - (1-c_\varepsilon)e^{2c_\varepsilon s}} g|_{\{d_q^\varepsilon=s\}};$$

notice that, near p , $g_\varepsilon = g$. We then have $\phi \geq f \geq (d_q^\varepsilon)^2 - 2d_q^\varepsilon$ with equality at p . Hence

$$\Delta\phi(p) \geq \Delta((d_q^\varepsilon)^2 - 2d_q^\varepsilon) \geq 2(n-1) \min\left(1, (1-s)c_\varepsilon \frac{(1+c_\varepsilon) + (1-c_\varepsilon)e^{2c_\varepsilon s}}{(1+c_\varepsilon) - (1-c_\varepsilon)e^{2c_\varepsilon s}}\right),$$

where above we have used that Σ is minimal at p for g_ε . Finally, letting $\varepsilon \rightarrow 0$, we get $\Delta\phi(p) \geq 2(n-1)$. \square

The function f is smooth near $\partial\Sigma$ and $\partial_\nu f = 2$ on $\partial\Sigma$. So, if f was smooth, integrating $\Delta f \geq 2(n-1)$ on Σ and applying Stokes formula would give the expected result. Since *a priori* f is not smooth, we proceed as follows. Let $c = \frac{|\partial\Sigma|}{|\Sigma|}$ and assume that $c < n-1$. Then there is a smooth function u on Σ solving the problem:

$$\begin{cases} \Delta u = 2c & \text{on } \Sigma, \\ \partial_\nu u = 2 & \text{on } \partial\Sigma. \end{cases}$$

Let us consider $m_0 = \min_{\partial\Sigma} u$. Thus $u - m_0 \geq 0 = f$ on $\partial\Sigma$. Since $c < n-1$, the maximum principle for viscosity subsolutions [7, Theorem 3.3] gives that $u - m_0 \geq f$ on Σ . Now, let $p \in \partial\Sigma$ be such that $u(p) = m_0$. Near p , both u and f are smooth, and we have $u - m_0 \geq f$,

$u(p) - m_0 = f(p)$, $\partial_\nu(u - m_0)(p) = 2 = \partial_\nu f(p)$ and $\Delta(u - m_0)(p) = 2c < 2(n - 1) \leq \Delta f(p)$, which is impossible. So we have proved that $c \geq (n - 1)$, that is, $(n - 1)|\Sigma| \leq |\partial\Sigma|$. \square

Remark. We state the above result for hypersurfaces. However, we can remark that the proof works in any codimension: for any minimal k -submanifold Σ with free boundary in M , one has $k|\Sigma| \leq |\partial\Sigma|$.

3. MIN-MAX THEOREMS

In this section, we recall some min-max constructions of free boundary minimal surfaces in Riemannian 3-manifolds with convex boundary. These constructions first appeared in the work of M. Grüter and J. Jost [17] for free boundary disks in convex domains of \mathbb{R}^3 and then they were extended to manifolds with convex boundary by J. Jost [20]. Here we give a presentation of these constructions as they appear in the work of T.H. Colding and C. De Lellis [6] for the no boundary case and in the work of M.M.-C. Li [23] for the boundary case.

We study two different cases: the first one applies to compact 3-manifolds with smooth boundary; the second deals with compact 3-manifolds with piecewise smooth boundary and we want to prevent the minimal surface to attach to a certain part of the boundary.

3.1. The unconstrained case. Let M be a compact Riemannian 3-manifold with smooth boundary and $I = [a, b]$. A family $\{\Sigma_t\}_{t \in I}$ of closed subsets of M is a *generalized smooth family of surfaces*, or a *sweepout*, if there are finite subsets $T \subset I$ and $P \subset M$ such that:

- (a) $\mathcal{H}^2(\Sigma_t)$ is a continuous function of t ;
- (b) $\Sigma_t \rightarrow \Sigma_{t_0}$ in the Hausdorff topology whenever $t \rightarrow t_0$;
- (c) For every $t \in I \setminus T$, Σ_t is a compact surface in M with (possibly empty) boundary such that $\partial\Sigma_t = \Sigma_t \cap \partial M$ and this intersection is transverse;
- (d) For $t \in T$, $\Sigma_t \setminus P$ is a surface in $M \setminus P$ with boundary satisfying $\partial(\Sigma_t \setminus P) = (\Sigma_t \setminus P) \cap \partial M$ and this intersection is transverse;
- (e) Σ_t varies smoothly in $I \setminus T$;
- (f) For $\tau \in T$, $\Sigma_t \rightarrow \Sigma_\tau$ smoothly in $M \setminus P$ as $t \rightarrow \tau$.

Let Diff_0 be the set of diffeomorphisms of M that are isotopic to the identity. If $\{\Sigma_t\}_{t \in I}$ is a generalized smooth family of surfaces in M and $\psi : I \times M \rightarrow M$ is a smooth map such that $\psi_t = \psi(t, \cdot) \in \text{Diff}_0$, one can define a new generalized smooth family of surfaces by $\{\psi_t(\Sigma_t)\}_{t \in I}$. A set Λ of generalized smooth families of surfaces is said to be *saturated* if it is closed under the above operation and the cardinal of the set of singular points P is uniformly bounded among the elements of Λ .

One can define the maximal area of a generalized smooth family of surfaces $\{\Sigma_t\}_{t \in I}$ by

$$\mathcal{F}(\{\Sigma_t\}) = \max_{t \in I} \mathcal{H}^2(\Sigma_t).$$

Then, if Λ is a saturated set of generalized smooth families of surfaces, one defines its *width* with respect to the Riemannian metric g on M by

$$W(\Lambda, g) = \inf_{\sigma \in \Lambda} \mathcal{F}(\sigma).$$

Example 1. In this paper, we will only consider the case where M is the unit 3-ball

$$B = \{(x, y, z) \in \mathbb{R}^3 \mid x^2 + y^2 + z^2 \leq 1\}.$$

One generalized smooth family of surfaces is $\{\Gamma_t\}$ given by

$$\Gamma_t = B \cap \{z = t\}, \text{ for } t \in [-1, 1].$$

Besides, Λ_0 will denote the smallest saturated set of sweepouts containing $\{\Gamma_t\}$. We define $W(B, g) = W(\Lambda_0, g)$ for any Riemannian metric g on B .

Theorem 3.1. *Assume that M is endowed with a Riemannian metric g such that $\Pi_{\partial M}$ is positive definite. Let Λ be a saturated set of generalized smooth families of surfaces with $W(\Lambda, g) > 0$. Then there exist a collection $\{\Gamma_i\}_{1 \leq i \leq N}$ of free boundary minimal surfaces in M and a set $\{n_i\}_{1 \leq i \leq N}$ of positive integers such that*

$$W(\Lambda, g) = \sum_{i=1}^N n_i |\Gamma_i|.$$

Let us briefly explain the proof of the above result. Let $\{\Sigma_t^n\}$ be a *minimizing sequence* in Λ : $\lim_n \mathcal{F}(\{\Sigma_t^n\}) = W(\Lambda, g)$. If (t_n) is a sequence such that $\lim_n \mathcal{H}^2(\Sigma_{t_n}^n) = W(\Lambda, g)$, we say that $(\Sigma_{t_n}^n)$ is a *min-max sequence*. The basic idea of the proof consists in showing that the varifold limit of a min-max sequence takes the form $\sum_{i=1}^N n_i \mathbf{v}(\Gamma_i)$ for some free boundary minimal surfaces Γ_i .

The first step of the proof, the pull-tight procedure [23, Proposition 5.1], allows to assume that the minimizing sequence $\{\Sigma_t^n\}$ is such that any varifold limit of a min-max sequence $(\Sigma_{t_n}^n)$ is a freely stationary varifold.

The second step of the proof consists in selecting a min-max sequence $\Sigma^j = \Sigma_{t_j}^{n_j}$ such that Σ^j is $1/j$ -almost minimizing in any small annuli (see Definition 3.2 in [6] or Definition 3.6 in [23] replacing $\mathcal{I}\mathfrak{s}_{\text{out}}$ by $\mathcal{I}\mathfrak{s}_{\text{tan}}$) and such that, in any small annuli, Σ^j is smooth when j is large. The proof of this can be found in [6, Proposition 5.1] or [23, Proposition 6.4].

The last step is to prove the regularity of the support of the varifold limit $V = \lim \mathbf{v}(\Sigma^j)$. For the points in the interior of M , one can take a look at Sections 6 and 7 of [6], and for those on the boundary of M , at the work of Jost [20].

3.2. The constrained case. Now, let us consider the case where M is a compact Riemannian 3-manifold with piecewise smooth boundary whose boundary is the union $\partial M = \partial_0 M \cup \partial_+ M$ of two smooth pieces: $\partial_0 M$ and $\partial_+ M$, each one being a union of closures of connected components of $\partial M \setminus \mathcal{C}(M)$, such that $\partial_0 M \cap \partial_+ M = \mathcal{C}(M)$. Our aim is to allow constructions similar to those in the unconstrained case that prevent the free boundary to intersect $\partial_0 M$.

In this situation, we consider $I = [0, 1]$ and a family $\{\Sigma_t\}_{t \in I}$ of closed subsets of M is a *constrained generalized smooth family of surfaces*, or a *constrained sweepout*, if items (a), (b), (e) and (f) are satisfied and the others are replaced by

- (c') For every $t \in I \setminus (T \cup \{0\})$, Σ_t is a compact surface in $M \setminus \partial_0 M$ with (possibly empty) boundary satisfying $\partial \Sigma_t = \Sigma_t \cap \partial_+ M$ and this intersection is transverse;
- (d') For $t \in T$, $\Sigma_t \subset M \setminus \partial_0 M$ and $\Sigma_t \setminus P$ is a surface in $M \setminus P$ with boundary such that $\partial(\Sigma_t \setminus P) = (\Sigma_t \setminus P) \cap \partial_+ M$ and this intersection is transverse. Besides, $\Sigma_0 = \partial_0 M$.

In this context, Diff_0 will denote the set of diffeomorphisms of M that are isotopic to the identity and equal to the identity in a neighborhood of $\partial_0 M$. We can then consider saturated sets Λ of generalized smooth families of surfaces as in the unconstrained case.

If g is the Riemannian metric on M , we can then define $\mathcal{F}(\sigma)$ for $\sigma \in \Lambda$ and $W(\Lambda, g)$ as in the unconstrained case.

Definition 3.2. We say that M has a *free boundary mean-convex foliation near $\partial_0 M$* if there exists a non-negative continuous function f defined on an open neighborhood of $\partial_0 M$ such that $\partial_0 M = f^{-1}(0)$ and, outside $\mathcal{C}(M)$, f is a smooth submersion such that $\partial_\nu f = 0$ along $\partial_+ M \setminus \mathcal{C}(M)$ and $f^{-1}(t)$ has positive mean curvature in the ∇f direction for small t .

Notice that the property $\partial_\nu f = 0$ ensures that $f^{-1}(t)$ is a free boundary hypersurface. In Appendix A, we prove that we can construct such a foliation under some reasonable assumptions on the geometry of M .

Theorem 3.3. *Assume that M is endowed with a Riemannian metric g such that $\Pi_{\partial_+ M}$ is positive definite and (M, g) has a free boundary mean-convex foliation near $\partial_0 M$. Let Λ be a*

saturated set of generalized smooth families of surfaces satisfying $W(\Lambda, g) > |\partial_0 M|$. Then there exist a collection $\{\Gamma_i\}_{1 \leq i \leq N}$ of minimal surfaces in M with free boundary in $\partial_+ M \setminus \partial_0 M$ and a set $\{n_i\}_{1 \leq i \leq N}$ of positive integers such that

$$W(\Lambda, g) = \sum_{i=1}^N n_i |\Gamma_i|.$$

Example 2. In this paper, we will consider M the unit half-ball $B^+ = B \cap \{z \geq 0\}$ with $\partial_0 B^+ = B \cap \{z = 0\}$ and $\partial_+ B^+ = \partial B \cap \{z \geq 0\}$. One constrained generalized smooth family of surfaces is $\{\Gamma_t^+\}$ given by

$$\Gamma_t^+ = B^+ \cap \{z = t\}, \text{ for } t \in [0, 1].$$

We denote by Λ_0^+ the smallest saturated set of constrained sweepouts containing $\{\Gamma_t^+\}$.

The proof of Theorem 3.3 is based on similar ideas to those presented in the proof of [24, Theorem 2.1] by Marques and Neves.

In order to prove the result, we first construct a minimizing sequence $\{\Sigma_t^n\}$ satisfying: there are $a, \delta > 0$ such that

$$(3.1) \quad \forall n, t, \quad \mathcal{H}^2(\Sigma_t^n) \geq W(\Lambda, g) - \delta \implies d(\Sigma_t^n, \partial_0 M) \geq a.$$

To do so, let f be a function given by Definition 3.2 and define $S_t = f^{-1}(t)$. If f is defined on the open neighborhood Ω , there is $\varepsilon > 0$ such that $f > 2\varepsilon$ on $\partial\Omega \setminus \partial M$. We can change the definition of f outside $\Omega' = \{f < 2\varepsilon\}$ to extend f to a non-negative function on M with $f \geq 2\varepsilon$ outside Ω' . Then fix $0 < a < \frac{1}{2}d(S_\varepsilon, \partial_0 M)$ and $0 < \delta < \frac{1}{2}(W(\Lambda, g) - |\partial_0 M|)$. We will prove that such a and δ are convenient.

Let us consider a minimizing sequence $\{\Sigma_t^n\}$ in Λ . Fix n . Because of items (a), (b), (c'), and (d'), there is $b > 0$ such that

$$\mathcal{H}^2(\Sigma_t^n) \geq W(\Lambda, g) - \delta \implies d(\Sigma_t^n, \partial_0 M) \geq b.$$

We may assume that $b < a$; if not, we do nothing. We have the following lemma:

Lemma 3.4. *With the above notations, if $0 < \mu_1 < \mu_2 < \varepsilon$, there is a vector field X on M which vanishes near $\partial_0 M$, is tangent to $\partial_+ M$, and whose associated flow (Φ_s) satisfies the following:*

- for any $t \in [0, 1]$, if $\{\Sigma_t^n\} \subset \{f \geq \mu_1/3\}$, $\mathcal{H}^2(\Phi_s(\Sigma_t^n)) \leq \mathcal{H}^2(\Sigma_t^n)$ for each $s \geq 0$;
- for any $p \in \{f \geq \mu_1\}$, $\Phi_1(p) \in \{f \geq \mu_2\}$.

We postpone the proof of the above Lemma and finish the construction of our sweepout. Let $0 < \mu_1 < \mu_2 < \varepsilon$ be such that S_{μ_1} is in the b -tubular neighborhood of $\partial_0 M$ and S_{μ_2} is outside the a -tubular neighborhood of $\partial_0 M$. Let X and (Φ_s) be given by the above Lemma. Because of item (b), the function $t \mapsto \inf_{\Sigma_t^n} f$ is continuous and non-negative. Therefore, we can consider a smooth function $\theta : [0, 1] \rightarrow [0, 1]$ such that $\inf_{\Sigma_t^n} f \leq \theta(t) \leq \inf_{\Sigma_t^n} f + \mu_1/3$. Let $T : [0, 1] \rightarrow [0, 1]$ be a smooth function satisfying $T(x) = 0$ if $x \leq 2\mu_1/3$ and $T(x) = 1$ if $x \geq \mu_1$. Let us then consider the generalized smooth family of surfaces $\{\Phi_{T(\theta(t))}(\Sigma_t^n)\}$. It belongs to Λ . Let $t \in [0, 1]$. If $\Sigma_t^n \cap \{f \leq \mu_1/3\} \neq \emptyset$, $\theta(t) \leq 2\mu_1/3$, and then $\Phi_{T(\theta(t))}(\Sigma_t^n) = \Sigma_t^n$. If $\Sigma_t^n \cap \{f \leq \mu_1/3\} = \emptyset$, then $\mathcal{H}^2(\Phi_{T(\theta(t))}(\Sigma_t^n)) \leq \mathcal{H}^2(\Sigma_t^n)$. Thus we see that $\mathcal{F}(\{\Phi_{T(\theta(t))}(\Sigma_t^n)\}) \leq \mathcal{F}(\{\Sigma_t^n\})$. Besides, if $\mathcal{H}^2(\Phi_{T(\theta(t))}(\Sigma_t^n)) \geq W(\Lambda, g) - \delta$, then $\mathcal{H}^2(\Sigma_t^n) \geq W(\Lambda, g) - \delta$. In particular, $\Sigma_t^n \subset \{f \geq \mu_1\}$, $\theta(t) \geq \mu_1$, and then $\Phi_{T(\theta(t))}(\Sigma_t^n) = \Phi_1(\Sigma_t^n) \subset \{f \geq \mu_2\}$. Thus $d(\Phi_{T(\theta(t))}(\Sigma_t^n), \partial_0 M) \geq a$. Therefore $\{\Phi_{T(\theta(t))}(\Sigma_t^n)\}$ is a minimizing sequence which satisfies (3.1) (notice that X depends on b and thus on n).

Proof of Lemma 3.4. Let $c > 0$ be chosen latter. Let ϕ be a smooth non-negative function defined on \mathbb{R}_+ which is positive on $[0, \mu_2]$, vanishes on a neighborhood $[\varepsilon, +\infty)$, and satisfies $\phi' + c\phi \leq 0$. Let α be a smooth non-negative function on \mathbb{R}_+ vanishing near 0 and such that

$\alpha = 1$ on $[\mu_1/3, +\infty]$. Let X be the vector field defined by $X = \phi(f)\alpha(f)N$, where $N = \frac{\nabla f}{|\nabla f|}$ (extended by zero outside of Ω). We notice that this vector field vanishes close to $\partial_0 M$ and is tangent to $\partial_+ M$.

Let us fix a 2-plane $V = \text{span}(e_1, e_2)$ in $T_p M$ where $p \in \{f \geq \mu_1/3\}$ and compute $\text{div}_V X$. We may assume that $p \in \{f < \varepsilon\}$. First we notice that $\alpha(f) = 1$ at p and we may assume $e_1 \in T_p S_{f(p)}$. Let $g \in T_p S_{f(p)}$ be such that (e_1, g, N) is an orthonormal basis of $T_p M$. Then

$$\begin{aligned} \text{div}_V X &= (\nabla_{e_1} \phi(f)N, e_1) + (\nabla_{e_2} \phi(f)N, e_2) \\ &= \phi(f)(\nabla_{e_1} N, e_1) + \phi'(f)(e_2, \nabla f)(N, e_2) + \phi(f)(\nabla_{e_2} N, e_2). \end{aligned}$$

Since $e_2 = (e_2, g)g + (e_2, N)N$, we have

$$\begin{aligned} (\nabla_{e_2} N, e_2) &= (e_2, g)(e_2, N)(\nabla_N N, g) + (e_2, g)^2(\nabla_g N, g) \\ &= (e_2, g)(e_2, N)(\nabla_N N, g) + (1 - (e_2, N)^2)(\nabla_g N, g). \end{aligned}$$

So, if $H_0 > 0$ is a lower bound on the mean curvature of S_t and keeping in mind that ϕ is non-negative and $\phi' \leq -c\phi \leq 0$, we have

$$\begin{aligned} \text{div}_V X &= -\phi(f)H_{S_{f(p)}}(p) + \phi'(f)(e_2, N)^2(\nabla f, N) \\ &\quad + \phi(f) \left((e_2, g)(e_2, N)(\nabla_N N, g) - (e_2, N)^2(\nabla_g N, g) \right) \\ &\leq -\phi(f)H_0 + \phi'(f)(e_2, N)^2k + \frac{\varepsilon}{2}\phi(f) + \frac{1}{2\varepsilon}(e_2, N)^2K^2\phi(f) + (e_2, N)^2K\phi(f) \\ &\leq \phi(f) \left(\frac{\eta}{2} - H_0 \right) + (e_2, N)^2 \left(k\phi'(f) + \left(K + \frac{K^2}{2\eta} \right) \phi(f) \right) \end{aligned}$$

for any $\eta > 0$, where $k > 0$ is a lower bound on $(\nabla f, N)$ and K is an upper bound on the norm of the operator $\nabla \cdot N$. So choosing $\eta < H_0$ and $c > \frac{1}{k}(K + \frac{K^2}{2\eta})$ ensures that $\text{div}_V X \leq 0$. Notice that, along the flow associated to X , the function f is increasing and X does not vanish on $\{\mu_1/3 \leq f \leq \mu_2\}$. Thus, multiplying X by some positive constant, we can ensure the second item of the Lemma. Finally, since $\text{div}_V X \leq 0$ for any 2-plane V on $\{f \geq \mu_1/3\}$, the first item is true by the first variation of area formula. \square

Once the construction of a minimizing sequence $\{\Sigma_t^n\}$ satisfying (3.1) is done, the rest of the proof is similar to the proof of [24, Theorem 2.1] by Marques and Neves. The pull-tight procedure and the selection of a sequence that is almost-minimizing in any small annuli can be done away from $\partial_0 M$. This ensures the existence of a min-max sequence $\Sigma_{t_j}^{n_j}$ that stays away from $\partial_0 M$ and then the regularity of its varifold limit.

4. TOPOLOGICAL CONTROL

In this section, we explain the topological control we have on the free boundary minimal surfaces produced by the above constructions. The result is a consequence of the work of De Lellis and Pellandini [8] (see also the recent result in [11]).

We denote by \mathcal{O} (resp. \mathcal{O}_∂) the set of compact orientable connected surfaces without boundary (resp. with nonempty boundary). Let \mathcal{N} be the set of compact nonorientable connected surfaces with (possibly empty) boundary. An element Γ of \mathcal{O} or \mathcal{O}_∂ is homeomorphic to the connected sum of the sphere \mathbb{S}^2 and $\mathbf{g}(\Gamma)$ tori \mathbb{T}^2 to which $\mathbf{k}(\Gamma)$ disks are removed. An element Γ of \mathcal{N} is homeomorphic to the connected sum of $\mathbf{g}(\Gamma)$ projective planes P^2 to which $\mathbf{k}(\Gamma)$ disks are removed (see [13]). $\mathbf{g}(\Gamma)$ is called the *genus* of the surface of Γ .

For a surface Σ , whose connected components are the Γ_i , we define

$$\mathbf{t}(\Sigma) = \sum_{\Gamma_i \in \mathcal{O}} 2\mathbf{g}(\Gamma_i) + \sum_{\Gamma_i \in \mathcal{O}_\partial} (2\mathbf{g}(\Gamma_i) + \mathbf{k}(\Gamma_i) - 1) + \sum_{\Gamma_i \in \mathcal{N}} (\mathbf{g}(\Gamma_i) + \mathbf{k}(\Gamma_i) - 1).$$

From the above constructions, we recall that at the second step we obtain a min-max sequence $(\Sigma_{t_j}^j)$ such that $\Sigma_{t_j}^j$ is $1/j$ -almost minimizing in any small annuli and, in any small annuli, $\Sigma_{t_j}^j$ is smooth. Moreover, as varifolds, $\mathbf{v}(\Sigma_{t_j}^j) \rightarrow \sum_{i=1}^N n_i \mathbf{v}(\Gamma_i)$, where the Γ_i are free boundary minimal surfaces.

We can now state our control on the topology (compare with [8, Theorem 1.6]).

Theorem 4.1. *Assume that any surface Σ_t appearing in Λ is orientable for $t \in I \setminus T$. Let $(\Sigma_{t_j}^j)$ be a min-max sequence as above. Then*

$$\mathbf{t}\left(\bigcup_{i=1}^n \Gamma_i\right) \leq \liminf_{j \rightarrow \infty} \liminf_{t \rightarrow t_j} \mathbf{t}(\Sigma_t^j).$$

Let us explain how one can adapt the arguments in [8]. First, let us explain a type of surgery that we will use for orientable surfaces. If Σ is a compact surface with boundary, an *open strip* in Σ is an open subset $S \subset \Sigma$ that is homeomorphic to $(0, 1) \times [0, 1]$. Notice that the homeomorphism sends $\partial\Sigma \cap S$ to $(0, 1) \times \{0, 1\}$, thus an open strip joins two sub-arcs of $\partial\Sigma$. An *open half-disk* in Σ is an open subset $D \subset \Sigma$ that is homeomorphic to

$$\{(x, y) \in \mathbb{R}^2 \mid x^2 + y^2 < 1 \text{ and } y \geq 0\}.$$

Here the homeomorphism sends $\partial\Sigma \cap D$ to $(-1, 1) \times \{0\}$.

Definition 4.2. Let Σ and Σ' be two compact oriented surfaces. We say that Σ' is *obtained from Σ by cutting away a neck* if

- either $\Sigma \setminus \Sigma'$ is homeomorphic to $\mathbb{S}^1 \times (0, 1)$ and $\Sigma' \setminus \Sigma$ is homeomorphic to the disjoint union of two open disks,
- or $\Sigma \setminus \Sigma'$ is an open strip in Σ and $\Sigma' \setminus \Sigma$ is the disjoint union of two open half-disks in Σ' .

We say that $\tilde{\Sigma}$ is *obtained from Σ through surgery* if there is a finite number of surfaces

$$\Sigma_0 = \Sigma, \Sigma_1, \dots, \Sigma_N = \tilde{\Sigma}$$

such that, for any $0 \leq k \leq N - 1$,

- either Σ_{k+1} is homeomorphic to Σ_k ,
- or Σ_{k+1} is obtained from Σ_k by cutting away a neck.

Assume that Σ' is obtained from Σ by cutting away a neck and let us compare $\mathbf{t}(\Sigma)$ with $\mathbf{t}(\Sigma')$. If we are in the first item, we have two possibilities. The first one is when the annulus does not separate Σ ; then, in this case, Σ' and Σ have the same number of connected components and exactly one of them sees its genus decreased by 1 so that $\mathbf{t}(\Sigma') = \mathbf{t}(\Sigma) - 2$. If the annulus separates Σ , then one connected component Γ of Σ gives birth to two connected components Γ'_1 and Γ'_2 of Σ' with $\mathbf{g}(\Gamma'_1) + \mathbf{g}(\Gamma'_2) = \mathbf{g}(\Gamma)$ and $\mathbf{k}(\Gamma'_1) + \mathbf{k}(\Gamma'_2) = \mathbf{k}(\Gamma)$. Depending on whether $\mathbf{k}(\Gamma'_i) = 0$ or not, we have $\mathbf{t}(\Sigma') = \mathbf{t}(\Sigma)$ or $\mathbf{t}(\Sigma) - 1$. If we are in the second item, we also have several cases to consider. First, the strip can join two different connected components of $\partial\Sigma$. In this case, Σ' and Σ have the same number of connected components and exactly one of them sees \mathbf{k} decreased by 1 so that $\mathbf{t}(\Sigma') = \mathbf{t}(\Sigma) - 1$. If the strip joins two sub-arcs of the same connected component of $\partial\Sigma$, then the strip may separate Σ or not. In the first case, one connected component Γ of Σ gives birth to two connected components Γ'_1 and Γ'_2 of Σ' with $\mathbf{g}(\Gamma'_1) + \mathbf{g}(\Gamma'_2) = \mathbf{g}(\Gamma)$ and $\mathbf{k}(\Gamma'_1) + \mathbf{k}(\Gamma'_2) = \mathbf{k}(\Gamma) + 1$. Since $\mathbf{k}(\Gamma'_i) \neq 0$ in this case, we have $\mathbf{t}(\Sigma') = \mathbf{t}(\Sigma)$. If the strip does not separate Σ , then there is a connected component of Σ which

sees its genus decreased by 1 and \mathbf{k} increased by 1, so $\mathbf{t}(\Sigma') = \mathbf{t}(\Sigma) - 1$. In any cases we see that $\mathbf{t}(\Sigma') \leq \mathbf{t}(\Sigma)$.

Concerning the topology of compact surfaces, we have the following result (see [13, p. 101]):

Lemma 4.3. *Let Γ be a compact connected surface with genus \mathbf{g} and \mathbf{k} boundary connected components. Then, if $\Gamma \in \mathcal{O}$, $H^1(\Gamma) = \mathbb{Z}^{2\mathbf{g}}$; if $\Gamma \in \mathcal{O}_\partial$, $H^1(\Gamma) = \mathbb{Z}^{2\mathbf{g}+\mathbf{k}-1}$; and, if $\Gamma \in \mathcal{N}$, $H^1(\Gamma) = \mathbb{Z}^{\mathbf{g}-1} \times \mathbb{Z}_2$ when $\mathbf{k} = 0$ and $H^1(\Gamma) = \mathbb{Z}^{\mathbf{g}+\mathbf{k}-1}$ when $\mathbf{k} \neq 0$.*

Let us start the proof of Theorem 4.1. Let $\Gamma = \cup_{i=1}^n \Gamma_i$ be the support of $\lim \mathbf{v}(\Sigma_{t_j}^j)$ and $m_i = \mathbf{t}(\Gamma_i)$. By Lemma 4.3, there are m_i curves $\gamma_i^1, \dots, \gamma_i^{m_i}$ in Γ_i such that, if k_1, \dots, k_{m_i} are integers such that $k_1 \gamma_i^1 + \dots + k_{m_i} \gamma_i^{m_i}$ is homologically trivial in Γ_i , then $k_l = 0$ for each l . Notice that we can find $\mu > 0$ such that $d(\gamma_i^l, \partial M) > \mu$ for any i, l .

For $\varepsilon > 0$, we denote by $V_\varepsilon(X)$ the ε -tubular neighborhood of $X \subset M$:

$$V_\varepsilon(X) = \{p \in M \mid d(p, X) < \varepsilon\}.$$

We can choose $\varepsilon_0 < \mu$ such that there is a smooth tubular neighborhood retraction of $V_{2\varepsilon_0}(\Gamma)$ onto Γ .

We have (see [8, Proposition 2.3]):

Proposition 4.4. *Let $\varepsilon \leq \varepsilon_0$ be positive. For j sufficiently large and t close enough to t_j , we can find a surface $\tilde{\Sigma}_t^j$ obtained from Σ_t^j through surgery and satisfying:*

- $\tilde{\Sigma}_t^j$ is contained in $V_{2\varepsilon}(\Gamma)$;
- $\tilde{\Sigma}_t^j \cap V_\varepsilon(\Gamma) = \Sigma_t^j \cap V_\varepsilon(\Gamma)$.

Proof. Let $\Omega = V_{2\varepsilon}(\Gamma) \setminus \overline{V_\varepsilon(\Gamma)}$. Since Γ is the support of $\lim \mathbf{v}(\Sigma_{t_j}^j)$, we have

$$\lim_{j \rightarrow \infty} \limsup_{t \rightarrow t_j} \mathcal{H}^2(\Sigma_t^j \cap \Omega) = 0.$$

Thus, for $\eta > 0$, we can find a positive integer N and $\delta_j > 0$ such that

$$\mathcal{H}^2(\Sigma_t^j \cap \Omega) < \eta \quad \text{for } j \geq N \quad \text{and} \quad |t - t_j| < \delta_j.$$

If $\Delta_\sigma = \{p \in M \mid d(p, \Gamma) = \sigma\}$, by the coarea formula, we have

$$\int_\varepsilon^{2\varepsilon} \mathcal{H}^1(\Sigma_t^j \cap \Delta_\sigma) d\sigma \leq C \mathcal{H}^2(\Sigma_t^j \cap \Omega) < C\eta,$$

for some constant C independent of t and j . Thus $\mathcal{H}^1(\Sigma_t^j \cap \Delta_\sigma) \leq 2C\eta/\varepsilon$ for a set of σ of measure at least $\varepsilon/2$. We can then chose σ such that Δ_σ intersects Σ_t^j transversally and $\mathcal{H}^1(\Sigma_t^j \cap \Delta_\sigma) \leq 2C\eta/\varepsilon$.

Notice that there are positive constants λ and K such the following is true. For $s \in (0, 2\varepsilon)$, any simple curve γ in Δ_s with length less than λ satisfies:

- if γ is closed then it bounds an open disk $D \subset \Delta_s$ with $\text{Diam}(D) \leq K \text{Length}(\gamma)$;
- if the end-points of γ are in $\partial \Delta_s$ then there is an open half-disk $D \subset \Delta_s$ such that $\partial D \setminus \partial M = \gamma \setminus \partial M$ and $\text{Diam}(D) \leq K \text{Length}(\gamma)$.

We may assume that $2C\eta/\varepsilon < \lambda$. Since $\Sigma_t^j \cap \Delta_s$ is transverse, it is the union of a finite number of curves that are either closed or have end-points in $\partial \Delta_s$. In any case, the above properties apply and give the expected result as in [8]. Notice that one has to consider first an innermost curve in $\Sigma_t^j \cap \Delta_s$ to do the construction of the proof of [8, Proposition 2.3]. \square

The proof of Simon's Lifting Lemma [8, Proposition 2.1] allows to lift a closed curve $\gamma \in \Gamma_i$ to a closed curve $\tilde{\gamma}$ in $\Sigma_{t_j}^j$ in a tubular neighborhood of γ . So the whole proof of [8, Theorem 1.6] can be carried out in the $\mu/2$ -tubular neighborhood of $\cup_{i,l} \gamma_i^l$. This gives Theorem 4.1.

5. RIGIDITY OF THE HALF-BALL

In this section, we state and prove a rigidity statement for the Euclidean half-ball. More precisely, we have the following result:

Theorem 5.1. *Let M be a compact connected n -manifold with piecewise smooth boundary whose boundary is made up of two smooth pieces, say Σ and Δ , such that $\Sigma \cap \Delta = \mathcal{C}(M)$. Consider on M a Riemannian metric g such that:*

- $\text{Ric} \geq 0$;
- the mean curvature H_Σ of Σ with respect to the inward unit normal satisfies $H_\Sigma \geq n - 1$;
- Δ is totally geodesic and isometric to the Euclidean $(n - 1)$ -ball of radius $R > 0$;
- Σ and Δ meet orthogonally.

Then $R \leq 1$ and, if $R = 1$, (M, g) is isometric to the Euclidean unit half-ball of dimension n .

Notice that *a priori* we do not assume that M is diffeomorphic to the Euclidean half-ball.

The rest of this section is devoted to the proof of the above statement. The proof is inspired by the work C. Xia [29] which is based on the work of R.C. Reilly [27].

On Δ , let d be the distance function to $\partial\Delta$ and consider on ∂M the continuous function

$$f : p \mapsto \begin{cases} (2Rd - d^2)(p) & \text{if } p \in \Delta, \\ 0 & \text{if } p \in \Sigma. \end{cases}$$

Notice that $(2Rd - d^2)$ equals to R^2 minus the squared distance to the center of Δ . Then let u be the function on M that solves

$$\begin{cases} \bar{\Delta}u = -2n & \text{on } M, \\ u = f & \text{on } \partial M. \end{cases}$$

We notice that, by elliptic regularity, u is smooth up to ∂M except along $\partial\Delta = \partial\Sigma = \mathcal{C}(M)$. Consider the function $F = \frac{1}{2}|\bar{\nabla}u|^2 + 2u$ on $M \setminus \mathcal{C}(M)$. Using Bochner formula together with $\text{tr } \bar{\nabla}^2 u = \bar{\Delta}u = -2n$, we first have

$$(5.1) \quad \begin{aligned} \bar{\Delta}F &= (\bar{\nabla}u, \bar{\nabla}\bar{\Delta}u) + |\bar{\nabla}^2 u|^2 + \text{Ric}(\bar{\nabla}u, \bar{\nabla}u) + 2\bar{\Delta}u \\ &\geq |\bar{\nabla}^2 u + 2g|^2 + 4n - 4n = |\bar{\nabla}^2 u + 2g|^2 \geq 0. \end{aligned}$$

So F is subharmonic. Let us compute $\partial_\nu F$ along Σ and Δ . Observe that

$$\frac{1}{2}\partial_\nu |\bar{\nabla}u|^2 = \bar{\nabla}^2 u(\nu, \bar{\nabla}u) = \bar{\nabla}^2 u(\nu, \nabla f) + \chi \bar{\nabla}^2 u(\nu, \nu),$$

where $\chi = \partial_\nu u$. Since $\text{tr } \bar{\nabla}^2 u = -2n$, if $(e_i)_{1 \leq i \leq n-1}$ is an orthonormal basis of $T\partial M$, we have

$$\begin{aligned} \bar{\nabla}^2 u(\nu, \nu) &= -2n - \sum_i \bar{\nabla}^2 u(e_i, e_i) \\ &= -2n - \sum_i (\bar{\nabla}_{e_i}(\nabla f + \chi\nu), e_i) \\ &= -2n - \Delta f - \chi H, \end{aligned}$$

where $H = \text{tr}_{\partial M} \text{II}$. We also have

$$\bar{\nabla}^2 u(\nu, \nabla f) = (\bar{\nabla}_{\nabla f} \bar{\nabla}u, \nu) = -\text{II}(\nabla f, \nabla f) + (\nabla f, \nabla \chi).$$

Therefore

$$\frac{1}{2}\partial_\nu |\bar{\nabla}u|^2 = -\text{II}(\nabla f, \nabla f) + (\nabla f, \nabla \chi) - \chi(2n + \Delta f + \chi H)$$

and

$$\partial_\nu F = -\text{II}(\nabla f, \nabla f) + (\nabla f, \nabla \chi) - \chi(2(n-1) + \Delta f + \chi H).$$

On Σ , since $f = 0$ and $H_\Sigma \geq n - 1$, we have

$$(5.2) \quad \partial_\nu F = -\chi(2(n-1) + \chi H) \leq -(n-1)\chi(2 + \chi).$$

On Δ , since Δ is totally geodesic and isometric to the Euclidean $(n-1)$ -ball of radius R , $\Delta f = -2(n-1)$ and then

$$(5.3) \quad \partial_\nu F = (\nabla f, \nabla \chi).$$

Let us remark that at the center \bar{p} of Δ , we have $u(\bar{p}) = f(\bar{p}) = R^2$ and so $F(\bar{p}) \geq 2R^2$.

Claim 1. $R \leq 1$ and, if $R = 1$, F is constant and equal to 2.

Proof of Claim 1. Let us consider (q_k) a sequence of points in $M \setminus \mathcal{C}(M)$ such that

$$\lim F(q_k) = \sup_{M \setminus \mathcal{C}(M)} F.$$

We may assume that $q_k \rightarrow \bar{q} \in M$. Since F is subharmonic, we may even assume that $\bar{q} \in \partial M$. If $\bar{q} \in \Sigma \cap \Delta$, we will prove later (see Claim 2) that

$$\sup_{M \setminus \mathcal{C}(M)} F = \lim F(q_k) = 2R^2;$$

thus the maximum value of F is reached also at \bar{p} . So let us assume that $\bar{q} \in \partial M \setminus \mathcal{C}(M)$. Then necessarily $\partial_\nu F(\bar{q}) \geq 0$. If $\bar{q} \in \Sigma$, (5.2) implies $-2 \leq \chi(\bar{q}) \leq 0$ and then $F(\bar{q}) \leq 2$, since $F = \frac{1}{2}\chi^2$ on Σ . Hence $2 \geq F(\bar{q}) \geq F(\bar{p}) \geq 2R^2$; this implies $R \leq 1$ and, if $R = 1$, the maximum value of F is reached also at \bar{p} . Thus we assume $\bar{q} \in \Delta$.

On Δ , $F = 2R^2 + \frac{1}{2}\chi^2$. So, at the maximum, one has $\nabla \chi(\bar{q}) = 0$ or $\chi(\bar{q}) = 0$. In the first case, (5.3) implies $\partial_\nu F(\bar{q}) = 0$, so F is constant by the boundary maximum principle and at most 2 by (5.2) and $F = \frac{1}{2}\chi^2$ on Σ . Then $R \leq 1$ since $F(\bar{p}) \geq 2R^2$. In the case $\chi(\bar{q}) = 0$, we have $F(\bar{q}) = 2R^2$. As a consequence, $\chi = 0$ along Δ and thus $\nabla \chi(\bar{q}) = 0$, which, as above, implies that F is constant and at most 2 and $R \leq 1$. Moreover, if $R = 1$, F is constant and equal to 2. \square

Let us now finish the proof of Theorem 5.1 in the case $R = 1$ and F equals 2. Because of (5.1), (5.2), and (5.3), $\bar{\nabla}^2 u = -2g$ and $\text{Ric}(\bar{\nabla} u, \bar{\nabla} u) = 0$ on M , $\chi = 0$ on Δ , and $\chi = -2$ and $H = n - 1$ on Σ . Moreover, since $F \equiv 2$, $|\bar{\nabla} u|^2 = 4(1 - u)$, thus $\bar{\nabla} u$ has constant norm along a level set of u . So the second fundamental form of such a level set is given by $-(\bar{\nabla}_X \frac{\bar{\nabla} u}{2\sqrt{1-u}}, Y) = \frac{-1}{2\sqrt{1-u}} \bar{\nabla}^2 u(X, Y) = \frac{1}{\sqrt{1-u}}(X, Y)$ for X, Y tangent to the level set. By the maximum principle, $u \geq 0$ and $\{u = 0\} = \Sigma$.

At the center \bar{p} of Δ , we have $u(\bar{p}) = 1$ and $\bar{\nabla} u(\bar{p}) = 0$. If γ is a unit geodesic starting at \bar{p} , we have $\frac{d}{ds} u(\gamma(s))|_{s=0} = 0$ and $\frac{d^2}{ds^2} u(\gamma(s)) = -2$ so that $u(\gamma(s)) = 1 - s^2$. Thus we have proved that M is the image of the unit half-ball in $T_{\bar{p}}M$ by the exponential map. Let us fix v, y_1 and y_2 in $T_{\bar{p}}M$ with $|v| = 1$, v pointing inward and y_i normal to v . Let us define $Y_i(s) = d \exp_{\bar{p}}(sv)(sy_i)$ two Jacobi fields along $s \mapsto \exp_{\bar{p}}(sv)$ and $U = d \exp_{\bar{p}}(sv)v$ the unit speed vector along the geodesic (notice that Y_1 and Y_2 are tangent to the level set $\{u = 1 - s^2\}$). Then, by the above computation of the second fundamental forms of the level sets, we have

$$\frac{d}{ds}(Y_1, Y_2) = (\bar{\nabla}_U Y_1, Y_2) + (Y_1, \bar{\nabla}_U Y_2) = (\bar{\nabla}_{Y_1} U, Y_2) + (Y_1, \bar{\nabla}_{Y_2} U) = \frac{2}{s}(Y_1, Y_2).$$

Thus $(Y_1, Y_2) = s^2(y_1, y_2)$ and $\exp_{\bar{p}}$ is an isometry from the unit half-ball in $T_{\bar{p}}M$ to M . This finishes the proof of Theorem 5.1 when the following Claim is proved.

Claim 2. If $\bar{q} \in \Sigma \cap \Delta = \mathcal{C}(M)$, then $\lim F(q_k) = 2$.

Proof of Claim 2. First, let δ denote the distance function to Σ . For $\varepsilon > 0$ small enough, δ is smooth on $\{\delta \leq \varepsilon\}$ and equal to d on $\Delta \cap \{\delta \leq \varepsilon\}$. Let $(e_i)_{1 \leq i \leq n-1}$ be an orthonormal basis of Σ . Completing it by $\bar{\nabla}\delta$, we can compute

$$\bar{\Delta}\delta = \sum_i (\bar{\nabla}_{e_i} \bar{\nabla}\delta, e_i) = - \sum_i \Pi_\Sigma(e_i, e_i) \leq -(n-1) \quad \text{on } \Sigma.$$

Reducing $\varepsilon > 0$ if necessary, we may assume that $\bar{\Delta}\delta \leq -(n - \frac{3}{2})$ on $\{\delta \leq \varepsilon\}$. Since u is bounded in M , we can find a constant $c > 0$ such that $u \leq c\delta$ on $\partial\{\delta \leq \varepsilon\}$ and $2n \leq c(n - \frac{3}{2})$. We then have $\bar{\Delta}u = -2n \geq -c(n - \frac{3}{2}) \geq \bar{\Delta}(c\delta)$ on $\{\delta \leq \varepsilon\}$. Hence, by the maximum principle, we have $0 \leq u \leq c\delta$ on $\{\delta \leq \varepsilon\}$.

Let us consider a local chart of M near \bar{q} : we see a neighborhood of \bar{q} in M as a neighborhood of the origin in $\mathbb{R}_+^2 \times \mathbb{R}^{n-2}$ such that $\{x_2 = 0\}$ corresponds to Δ and $\{x_1 = 0\}$ corresponds to Σ . The Riemannian metric is then given by $g = (g_{ij})$ and, since Σ and Δ meet orthogonally, we may assume that g is the identity at the origin. The sequence of points (q_k) can then be written as $q_k = a_k + r_k \theta_k$, where a_k is the projection of q_k on $\{(0, 0)\} \times \mathbb{R}^{n-2}$, $r_k \in \mathbb{R}_+^*$ and $\theta_k \in \mathbb{S}^1 \times \{0\}$. We have $a_k \rightarrow 0$, $r_k \rightarrow 0$, and we can assume that $\theta_k \rightarrow \bar{\theta} \in \mathbb{S}^1 \times \{0\}$. We can see u as being defined on $\mathbb{R}_+^2 \times \mathbb{R}^{n-2}$ close to the origin and we define $u_k(x) = \frac{1}{r_k} u(r_k x + a_k)$. The function u solves

$$\frac{1}{\sqrt{\det g}} \sum_{i,j} \partial_i (\sqrt{\det g} g^{ij} \partial_j u) = -2n,$$

where g^{ij} is the inverse matrix of g . As a consequence, u_k solves

$$\frac{1}{\sqrt{\det g_k}} \sum_{i,j} \partial_i (\sqrt{\det g_k} g_k^{ij} \partial_j u_k) = -2nr_k,$$

where $g_k(x) = g(r_k x + a_k)$. We see that (g_k) goes uniformly to the identity on the quarter-ball of radius ρ for any $\rho > 0$. Moreover, we know that $0 \leq u \leq c\delta$ and $\delta \leq Kx_1$ for some $K > 0$; thus $0 \leq u_k \leq cKx_1$. This implies that the u_k 's are uniformly bounded in the quarter-ball of radius ρ .

On the boundary, $u_k = 0$ on $\{x_1 = 0\}$ and $u_k(x) = \frac{1}{r_k}(2Rd - d^2)(r_k x + a_k)$ on $\{x_2 = 0\}$; we notice that the last boundary value converges uniformly to $2Rx_1$. Let D_ρ be the quarter-disk in \mathbb{R}_+^2 of radius ρ . Because of the above properties, we can apply Schauder estimates up to the boundary [14, Corollary 6.7] to prove that u_k has uniformly bounded $C^{2,\alpha}$ -norm in $(D_\rho \setminus D_\varepsilon) \times [-\rho, \rho]^{n-2}$ for any $0 < \varepsilon < \rho$. As a consequence, we can consider a subsequence which converges to a function \bar{u} defined on $(\mathbb{R}_+^2 \setminus \{(0, 0)\}) \times \mathbb{R}^{n-2}$ (the convergence is C^2 -uniform on any compact subsets). Moreover, \bar{u} solves $\Delta_0 \bar{u} = 0$ (the Euclidean Laplacian) and is equal to 0 on $\{x_1 = 0\}$ and to $2Rx_1$ on $\{x_2 = 0\}$. We also notice that $0 \leq \bar{u} \leq cKx_1$, so the function extends continuously by 0 to $\{(0, 0)\} \times \mathbb{R}^{n-2}$. We assert that actually $\bar{u}(x) = 2Rx_1$. Let $\bar{v} = \bar{u} - 2Rx_1$; it is a solution to $\Delta_0 \bar{v} = 0$ on $\mathbb{R}_+^2 \times \mathbb{R}^{n-2}$ which extends continuously by 0 on the boundary. Thus, by Schwarz reflection along the boundary, we can extend it to a solution to $\Delta_0 \bar{v} = 0$ on \mathbb{R}^n . We also notice that $|\bar{v}| \leq \max(cK, 2R)|x_1|$. This implies that $|\bar{\nabla}\bar{v}|$ is uniformly bounded on \mathbb{R}^n and Liouville theorem gives that there is a vector $a \in \mathbb{R}^n$ and a constant b such that $\bar{v}(x) = (a, x) + b$. Since $\bar{v} = 0$ on $\{x_1 = 0\}$ and $\{x_2 = 0\}$, we have $b = 0$, $a = 0$, and $\bar{u} = 2Rx_1$.

Finally, since $u_k \rightarrow \bar{u}$ C^2 -uniformly on $(D_2 \setminus D_{1/2}) \times [-1, 1]^{n-2}$, we obtain

$$F(q_k) = \frac{1}{2} |\bar{\nabla}u|^2(q_k) + 2u(q_k) = \frac{1}{2} |\nabla_{g_k} u_k|^2(\theta_k) + 2u(q_k) \longrightarrow \frac{1}{2} |\nabla_0 \bar{u}|^2(\bar{\theta}) + 2u(\bar{q}) = 2R^2.$$

This finishes the proof of Claim 2 and the proof of Theorem 5.1. \square

6. LEAST AREA MINIMAL DISK

In this section, we prove Theorem 1.3. So let us consider (B, g) to be the 3-ball with a Riemannian metric with non-negative Ricci curvature and $\Pi_{\partial B} \geq g|_{\partial B}$. It was brought to our attention by R. Haslhofer that part of the below argument also appears in his recent work with D. Ketover [19] (see Proposition 2.4 therein).

The first step consists in proving the existence of a free boundary minimal disk in B . This is a consequence of the work of Jost [20, Theorem 4.1]. Let us briefly recall the construction. The family $\{\Gamma_t\}$ defined by

$$\Gamma_t = B \cap \{z = t\}, \text{ for } t \in [-1, 1],$$

is a sweepout of the ball B . Let Λ_0 be the smallest saturated set of sweepouts containing $\{\Gamma_t\}$. Actually, for any $\{\Sigma_t\} \in \Lambda_0$, there is $t_0 \in [-1, 1]$ such that Σ_{t_0} separates B into two parts of equal volume so that $|\Sigma_{t_0}|$ is larger than the isoperimetric profile of (B, g) for half the volume of (B, g) . As a consequence, $W(\Lambda_0, g) > 0$ and Theorem 3.1 implies the existence of free boundary minimal surfaces in (B, g) . Since $\mathbf{t}(\Gamma_t) = 0$ for any t , Theorem 4.1 ensures that these minimal surfaces are either disks, spheres or projective planes. Besides, these minimal surfaces must have a nonempty boundary by Fraser and Li [12, Lemma 2.2] (notice that projective planes are forbidden just by the topology of the ambient space). Thus we have the existence of a free boundary minimal disk in (B, g) .

By Fraser and Li [12, Theorem 1.2], the space of such minimal disks is compact. So there is a free boundary minimal disk Δ such that

$$|\Delta| = \inf\{|D|; D \text{ is a free boundary minimal disk in } (B, g)\}.$$

Since a free boundary minimal disk can be produced by min-max, we have $|\Delta| \leq W(\Lambda_0, g)$. Because of the ambient geometry and using $u \equiv 1$ in (2.1), Δ cannot be stable.

Proposition 6.1. *There is a sweepout $\{\Sigma_t\}_{t \in [-1, 1]} \in \Lambda_0$ with the following properties:*

- $\mathcal{F}(\{\Sigma_t\}) = |\Delta|$;
- $\{\Sigma_t\}_{t \in (-\varepsilon, \varepsilon)}$ is a piece of the nice foliation associated with Δ , for some $\varepsilon > 0$, such that $\Sigma_0 = \Delta$;
- for any $t \neq 0$, $\mathcal{H}^2(\Sigma_t) < |\Delta|$.

Proof. Let us consider $\{S_t\}_{t \in (-2\varepsilon, 2\varepsilon)}$ be the nice foliation associated with Δ (Lemma 2.1). We notice that $|S_t| < |\Delta|$ for $t \neq 0$. We fix $\eta > 0$ such that $\max(|S_\varepsilon|, |S_{-\varepsilon}|) \leq |\Delta| - \eta$. Let $\mathcal{N} = \cup_{t \in (-\varepsilon, \varepsilon)} S_t$ be a neighborhood of Δ and let M_+ and M_- be the connected components of $B \setminus \mathcal{N}$ such that $S_{\pm\varepsilon} \subset \partial M_{\pm}$. Let us consider M_+ (similar arguments can be applied to M_-). M_+ is diffeomorphic to B^+ . We are going to study the constrained min-max construction associated with $\partial_0 M_+ = S_\varepsilon$, $\partial_+ M_+ = M_+ \cap \partial B$ and the saturated set Λ_0^+ (see Example 2). On $\cup_{t \in [\varepsilon, 2\varepsilon)} S_t$, we consider the function f defined by $f(p) = t - \varepsilon$ if $p \in S_t$. The function f satisfies Definition 3.2, so M_+ has a free boundary mean-convex foliation near $\partial_0 M_+$. Moreover, $\Pi_{\partial_+ M_+} \geq g|_{\partial_+ M_+}$. Therefore, if $W(\Lambda_0^+, g) > |S_\varepsilon|$, there is at least one free boundary minimal surface S in M_+ with free boundary in $\partial_+ M_+$. As a consequence, Δ and S are two disjoint minimal surfaces in (B, g) , which is not possible by the Frankel property [12, Lemma 2.4].

Thus there is a constrained sweepout $\{\Sigma_t^+\}_{t \in [0, 1]} \in \Lambda_0^+$ of M_+ with $\Sigma_0^+ = S_\varepsilon$ such that

$$\mathcal{F}(\{\Sigma_t^+\}) \leq |S_\varepsilon| + \eta/2 < |\Delta|.$$

Similarly, there is a constrained sweepout $\{\Sigma_t^-\}_{t \in [0, 1]}$ of M_- with $\Sigma_0^- = S_{-\varepsilon}$ such that

$$\mathcal{F}(\{\Sigma_t^-\}) < |\Delta|.$$

We can then define

$$\Sigma_t = \begin{cases} \Sigma_{\theta^-(t)}^- & \text{if } t \in [-1, -\varepsilon], \\ \mathcal{S}_t & \text{if } t \in [-\varepsilon, \varepsilon], \\ \Sigma_{\theta^+(t)}^+ & \text{if } t \in [\varepsilon, 1], \end{cases}$$

where $\theta^-(t) = -\frac{t+\varepsilon}{1-\varepsilon}$ and $\theta^+(t) = \frac{t-\varepsilon}{1-\varepsilon}$. $\{\Sigma_t\}_{t \in [-1, 1]}$ is then a sweepout in Λ_0 with the expected properties. \square

A consequence of the above result is that $|\Delta| = W(\Lambda_0, g)$.

Proposition 6.2. Δ has index one.

Proof. We already know that Δ has index at least one. Let us assume that it has index at least two. Let λ_1 and λ_2 be the first two negative eigenvalues of the Jacobi operator and ϕ_1 and ϕ_2 be the associated eigenfunctions. Consider $\{\Sigma_t\}_{t \in [-1, 1]}$ the sweepout given by the preceding proposition. Using the notations of Lemma 2.1, for a function u defined on Δ , we consider $X_u(\Delta)$ its graph in a neighborhood of Δ . We know that the nice foliation, and thus the above sweepout, is given by

$$\Sigma_t = X_{u_t}(\Delta), \text{ for } t \in [-\varepsilon, \varepsilon],$$

where $\partial_t u_t|_{t=0} = \phi_1$. Let us define

$$\Sigma_{t,s} = X_{u_t+s\phi_2}(\Delta), \text{ for } (t,s) \in [-\varepsilon, \varepsilon]^2.$$

Since ϕ_1 and ϕ_2 are associated to negative eigenvalues, the Hessian of $F : (t,s) \mapsto \mathcal{H}^2(\Sigma_{t,s})$ at $(0,0)$ is negative definite (notice that $(0,0)$ is a critical point of F and see (2.1)). Since $F(t,0) < F(0,0)$ for $t \neq 0$, there is a function $\tilde{s} : [-\varepsilon, \varepsilon] \rightarrow [-\varepsilon, \varepsilon]$ such that $\tilde{s}(\pm\varepsilon) = 0$ and $F(t, \tilde{s}(t)) < F(0,0) = |\Delta|$ for any $t \in [-\varepsilon, \varepsilon]$. As a consequence, the sweepout $\{\tilde{\Sigma}_t\}_{t \in [-1, 1]}$ defined by

$$\tilde{\Sigma}_t = \begin{cases} \Sigma_t & \text{if } t \notin [-\varepsilon, \varepsilon] \\ \Sigma_{t, \tilde{s}(t)} & \text{if } t \in [-\varepsilon, \varepsilon] \end{cases}$$

satisfies to $\mathcal{F}(\{\tilde{\Sigma}_t\}) < |\Delta| = W(\Lambda_0, g)$, which is impossible since $\{\tilde{\Sigma}_t\} \in \Lambda_0$. So Δ has index one. \square

Let us remark that a general index estimate can be found in [10]. The first two items of Theorem 1.3 are then proven. The third one is then a consequence of Theorem 1.2 by the second author [26].

When $L(\partial\Delta) = 2\pi$, the equality case of Theorem 1.2 gives that Δ is totally geodesic and isometric to the Euclidean unit disk. So Theorem 5.1 gives that both sides of Δ are isometric to the unit half-ball, and then (B, g) is isometric to the unit ball, in Euclidean space. This finishes the proof of Theorem 1.3.

Remark. In case the sectional curvature of g is non-negative, we can use Proposition 2.2 and are able to estimate the area of Δ by $|\Delta| \leq \frac{1}{2}L(\partial\Delta) \leq \pi$. In case $|\Delta| = \pi$, the rigidity is then a direct consequence of the above arguments.

APPENDIX A. CONSTRUCTION OF A FREE BOUNDARY MEAN-CONVEX FOLIATION

In Section 3.2, we define the notion of a free boundary mean-convex foliation near $\partial_0 M$. In this section, we construct such a foliation under some simple hypotheses. If ν_0 and ν_+ are the inward unit conormal for $\partial_0 M$ and $\partial_+ M$ along $\mathcal{C}(M)$, the *inner angle* between $\partial_0 M$ and $\partial_+ M$ is the one between ν_0 and ν_+ .

Proposition A.1. *Let (M, g) be a Riemannian n -manifold with piecewise smooth boundary whose boundary is the union $\partial M = \partial_0 M \cup \partial_+ M$ of two smooth parts. If $\partial_0 M$ has positive mean curvature and the inner angle between $\partial_0 M$ and $\partial_+ M$ is at most $\pi/2$, then M has a free boundary mean-convex foliation near $\partial_0 M$.*

The hypotheses in the above result should be compared with [18, Definition 2.2] which is used to do a constrained min-max construction in the Almgren-Pitts setting.

The rest of the appendix is devoted to the proof of Proposition A.1. It is made of several steps. In order to do the construction, we start with a parametrization of a neighborhood of $\partial_0 M$ in M by $\partial_0 M \times [0, 1)$ with a second coordinate y such that ∂_y is unitary and orthogonal to $\mathcal{C}(M)$ along $\mathcal{C}(M)$.

A.1. Improving the coordinate system. In order to deal with points where the inner angle is $\pi/2$, we need to choose a better coordinate y . So let u be a positive function on $\partial_0 M$ such that $u = 1$ on $\mathcal{C}(M)$. Notice that we can choose the value of $\partial_\nu u$ as we want. Let us define the map $F : \partial_0 M \times [0, \varepsilon) \rightarrow \partial_0 M \times [0, 1); (a, z) \mapsto (a, u(a)z)$. Since u is positive, F is a diffeomorphism on its image and this defines a new parametrization of a neighborhood of $\partial_0 M$ in M .

We can consider a parametrization of a neighborhood of $\mathcal{C}(M)$ in $\partial_0 M$ by $\mathcal{C}(M) \times [0, \varepsilon)$ such that the second coordinate function x is the distance function in $\partial_0 M$ to $\mathcal{C}(M)$.

With the y coordinate, this gives a parametrization of a neighborhood of $\mathcal{C}(M)$ in M and defines two vector fields: ∂_y and ∂'_x . With the z coordinate, this gives a second parametrization of this neighborhood and two new vector fields: ∂_z and ∂_x . We have the equalities $\partial_z = u(a)\partial_y$ and $\partial_x = \partial'_x + z\partial_x u(a)\partial_y$ (notice that $\partial_x = \partial'_x$ on $\partial_0 M$).

Since $u = 1$ on $\mathcal{C}(M)$, $\partial_z = \partial_y$ and then $g(\nabla_{\partial_x} \partial_x, \partial_z) = g(\nabla_{\partial'_x} \partial'_x, \partial_y)$ on $\mathcal{C}(M)$. We also have $g(\partial_x, \partial_z) = (\partial'_x + z\partial_x u(a)\partial_y, \partial_y)$ on $\partial_+ M$. So, on $\mathcal{C}(M)$,

$$\partial_z g(\partial_x, \partial_z) = \partial_y g(\partial'_x, \partial_y) + \partial_x u(a) = \partial_y g(\partial'_x, \partial_y) - \partial_\nu u(a).$$

So, adjusting the value of $\partial_\nu u$, we can assume, for any $K \in \mathbb{R}_+$, that, on $\mathcal{C}(M)$,

$$(A.1) \quad \partial_z g(\partial_x, \partial_z) \geq K |g(\nabla_{\partial_x} \partial_x, \partial_z)|.$$

Let us also notice that since $\partial_0 M$ has positive mean curvature, $\{z = t\}$ has positive mean curvature (in the ∂_z direction) for small t . We are now using the parametrization of a neighborhood of $\mathcal{C}(M)$ in M by the coordinates $(q, x, z) \in \mathcal{C}(M) \times [0, \varepsilon) \times [0, \varepsilon)$ (see Figure 2). We then have a positive function $H : \mathcal{C}(M) \times [0, \varepsilon)^2 \rightarrow \mathbb{R}$ such that $H(q, x, t)$ is the mean curvature of $\{z = t\}$ at the point parametrized by (q, x, t) with respect to the ∂_z direction. The parametrization of this neighborhood gives a decomposition at (q, x, z) of any vector field Z as $Z = Z^x \partial_x + Z^z \partial_z + Z^\top$ with Z^\top is tangent to $\mathcal{C}(M) \times \{(x, z)\}$.

A.2. Construction of the foliation. By hypotheses, along $\mathcal{C}(M)$ the vector fields ∂_x and ∂_z are unitary, normal to $\mathcal{C}(M)$ and $(\partial_x, \partial_z) = \cos \alpha$ where $\alpha = \alpha(q) \in (0, \pi/2]$ is the inner angle at $q \in \mathcal{C}(M)$.

For $\eta > 0$, let us define $N_\eta = \{x^2 + z^2 \leq \eta^2\}$ and $E = \{z \geq x\}$ in $\mathcal{C}(M) \times [0, \varepsilon) \times [0, \varepsilon)$. Let us also denote by δ the distance function to $\partial_+ M$, i.e. $\{x = 0\}$ in the parametrization. If η is small enough, δ is smooth in $E \cap N_\eta$ (see A.6 below).

If $q \in \mathcal{C}(M)$, by hypotheses, the Riemannian metric at q can be written as $ds^2 + dx^2 + 2\cos \alpha dx dz + dz^2$ where ds^2 is some scalar product on $T_q \mathcal{C}(M)$ and $\alpha \in (0, \pi/2]$. As a consequence, as $(p, x, z) \in E$ converges to $(q, 0, 0)$, $\nabla \delta$ converges to $X_\alpha = \frac{1}{\sin \alpha} (\partial_x - \cos \alpha \partial_z)$ (see A.6 below).

Let ψ be a smooth function defined on \mathbb{R}_+ such that $\psi(0) = 0$, $\psi = 1$ on $[1, +\infty)$ and $\psi' > 0$ on $(0, 1)$ (the expression of ψ will be precised later). We then consider the vector field X on N_η defined by

$$X = \psi\left(\frac{x}{z}\right) \partial_x + (1 - \psi\left(\frac{x}{z}\right)) \nabla \delta$$

Notice that $X = \partial_x$ outside E so X is a smooth vector field in $N_\eta \setminus \mathcal{C}(M)$. On $E \cap N_\eta$, $X = (\psi(\frac{x}{z}) + (1 - \psi(\frac{x}{z}))(\nabla \delta)^x) \partial_x + (1 - \psi(\frac{x}{z}))(\nabla \delta)^z \partial_z + (1 - \psi(\frac{x}{z}))(\nabla \delta)^\top$. Since $\nabla \delta$ is close to

X_α for some $\alpha \in (0, \pi/2]$, there is $M > 0$ and, for any $\mu > 0$, there is an $\eta > 0$ such that in N_η

$$(A.2) \quad 1 - \mu \leq X^x \leq M$$

$$(A.3) \quad -M \leq X^z \leq \varepsilon$$

$$(A.4) \quad |X^\top| \leq \mu$$

As a consequence for η small the coordinate X^x never vanishes and we can define the vector field

$$Y = -\frac{X}{X^x}$$

whose Y^x coordinate is -1 .

Moreover, under the above estimates, there is η_1 such that any integral curve of Y starting from a point in $E \cap N_{\eta_1}$ stays in $E \cap N_\eta$ for positive time up to a time when it hits $\partial_+ M = \{x = 0\}$. Notice that, when $x = 0$, Y is a positive multiple of $-\nabla\delta$. So such an integral curve hits $\partial_+ M$ orthogonally. Besides there is $\eta_2 < \eta_1$ such that, in negative time, any integral curve of Y starting from $E \cap N_{\eta_2}$ hits $\{x = z\}$ in N_{η_1} .

Let us denote by (ϕ_t) the flow associated to the vector field Y (when it is defined). For example, if $p \in E \cap N_{\eta_1}$ has coordinates (q, x, z) , $\phi_t(p)$ is defined on the interval of positive time $[0, x]$ since the derivative of the x coordinates along Y is $Y^x = -1$ and $\phi_t(p)$ hits $\{x = 0\}$ at time x . For $s \in (0, \eta_1/\sqrt{2})$ we define

$$S_s = (\{z = s\} \setminus E) \cup \left(\bigcup_{t \in [0, s]} \phi_t(\{x = s = z\}) \right)$$

Notice that the two pieces of S_s are glued along $\{x = s = z\}$ and this gluing is smooth since Y extend smoothly to $-\partial_x$ outside E . So S_s is a smooth hypersurface which is normal to $\partial_+ M$ since it contains integral curve of the vectorfield Y . By construction the function f defined near $\partial_0 M$ by

$$p \mapsto \begin{cases} 0 & \text{if } p \in \partial_0 M \\ s & \text{if } p \in S_s \end{cases}$$

is well defined, continuous in a neighborhood of $\partial_0 M$, and is a smooth submersion outside of $\mathcal{C}(M)$. Moreover $\partial_\nu f = 0$ along $\partial_+ M$, since S_s contains integral curves of Y that hits $\partial_+ M$ orthogonally. The only aspect that we have to check is that S_s has positive mean curvature for s small.

A.3. Study of the mean curvature. If S_s does not have positive mean curvature for small s , there are two sequences $s_n \rightarrow 0$ and $p_n \in S_{s_n}$ such that the mean curvature of S_{s_n} at p_n is non-positive. By construction, the mean curvature of $\{z = s_n\}$ is positive for n large, so $p_n \in E$ and we may assume that $p_n \rightarrow \bar{p} \in \mathcal{C}(M)$. In order to analyze the mean curvature of S_{s_n} at p_n we fix a chart of $\mathcal{C}(M)$ near \bar{p} : so we identify $\mathcal{C}(M)$ with a small ball in \mathbb{R}^{n-2} such that \bar{p} is the origin and the Euclidean basis $(\partial_i)_{1 \leq i \leq n-2}$ is orthonormal for the induced metric at the origin.

Let us denote by B_r the open ball of radius r in \mathbb{R}^{n-2} centered at the origin. Let A be larger than $\cot \alpha$ for any inner angle α on $\mathcal{C}(M)$. We consider $V = \{(q, x, z) \in B_2 \times \mathbb{R}_+^2 \mid \frac{1}{2}x < z < 1 - A(x-2) \text{ and } z > \frac{1}{2}\}$ and $U = \{(q, x, z) \in B_4 \times \mathbb{R}_+^2 \mid \frac{1}{4}x < z < 15 + 10A - x\}$ (see Figure 1).

We then consider \mathcal{G}^k the set of C^k -Riemannian metric on U . Let \mathcal{Z}^k be the set of C^k -vector fields Z in V of the form $Z = Z^\top + Z^x \partial_x + Z^z \partial_z$ with $Z^\top \in \mathbb{R}^{n-2} \times \{(0, 0)\}$ such that $Z^x > \frac{1}{2}$ and $-\frac{A}{2} < Z^z < \frac{1}{4}$ and $|Z^\top| < \frac{1}{2}$. For $Z \in \mathcal{Z}^k$, we define on V the vector field

$$\mathcal{Y}(Z) = -\frac{\psi(\frac{x}{z})\partial_x + (1 - \psi(\frac{x}{z}))Z}{\psi(\frac{x}{z}) + (1 - \psi(\frac{x}{z}))Z^x}.$$

By the assumption on Z^x , the above vectorfield $\mathcal{Y}(Z)$ is well defined on V and has coordinate -1 in front of ∂_x . As a consequence of the bound on Z , a solution of $\dot{p} = \mathcal{Y}(Z)(p)$ starting from $(q, 1, 1) \in B_1 \times \mathbb{R}_+^2$ exists and lives in V up to time $t = 1$ where it exits V by $V_0 = V \cap \{x = 0\}$. We want to be more precise about the flow associated to $\mathcal{Y}(Z)$.

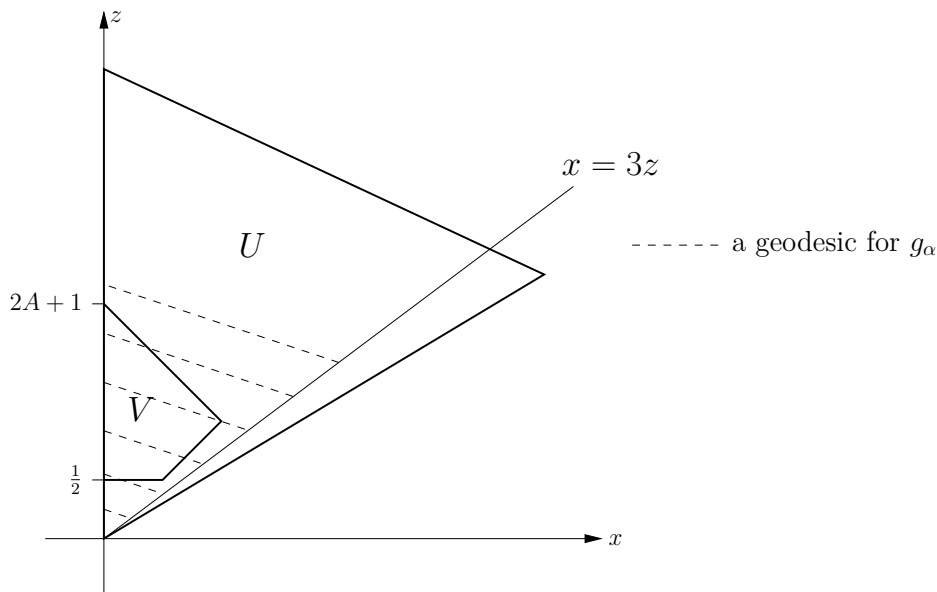
 FIGURE 1. The geodesics of g_α

A.4. The vector field to flow operator. We define $\mathcal{X}^k = \{X \in C^k(V, \mathbb{R}^n) \mid X^x = -1, -\frac{1}{2} < X^z < A, |X^\top| < 1\}$, $\mathcal{T} = \{F \in C^0([0, 1], \mathbb{R}^n) \mid F(0) \in B_1 \times \{(1, 1)\} \text{ and } \forall t \in [0, 1], F^x(t) = 1 - t, F(t) \in V\}$ and $T\mathcal{T} = \{G \in C^0([0, 1], \mathbb{R}^n) \mid G^z(0) = 0 \text{ and } \forall t \in [0, 1], G^x(t) = 0\}$. We also define the map

$$B : \begin{array}{ccc} B_1 \times \mathcal{X}^k \times \mathcal{T} & \rightarrow & T\mathcal{T} \\ (q, X, F) & \mapsto & \left(t \mapsto F(t) - (q, 1, 1) - \int_0^t X(F(s)) ds \right) \end{array}$$

Notice that because of the assumption on $X \in \mathcal{X}^k$, $B(q, X, F)$ belongs to $T\mathcal{T}$ for $(q, X, F) \in B_1 \times \mathcal{X}^k \times \mathcal{T}$. Moreover, for $(q, X) \in B_1 \times \mathcal{X}^k$, the solution of the ode $\dot{p} = X(p)$ starting at $(q, 1, 1)$ is defined up to time 1 and given by F satisfying $B(q, X, F) = 0$. Reciprocally if $B(\bar{q}, \bar{X}, \bar{F}) = 0$, \bar{F} is the solution of $\dot{p} = \bar{X}(p)$ starting at $(\bar{q}, 1, 1)$. As a consequence \bar{F} is C^{k+1} . The map B is C^k and its differential with respect to F at $(\bar{q}, \bar{X}, \bar{F})$ is given by

$$D_FB(\bar{q}, \bar{X}, \bar{F}) : \begin{array}{ccc} T\mathcal{T} & \rightarrow & T\mathcal{T} \\ G & \mapsto & \left(t \mapsto G(t) - \int_0^t D\bar{X}(\bar{F}(s))(G(s)) ds \right) \end{array}$$

The invertibility of this differential is given by the study of the linear ode $\dot{p} = D\bar{X}(\bar{F}(t))(p)$. Since $t \mapsto D\bar{X}(\bar{F}(t))$ is continuous and has vanishing x coordinate, $D_FB(\bar{q}, \bar{X}, \bar{F})$ is invertible. As a consequence for any $(\bar{q}, \bar{X}, \bar{F})$ such that $B(\bar{q}, \bar{X}, \bar{F}) = 0$ there is a C^k map Φ defined near (\bar{q}, \bar{X}) such that $B(q, X, \Phi(q, X)) = 0$. As a consequence $\Phi(q, X)$ is C^{k+1} in t . Moreover, since $\partial_t \Phi(q, X)(t) = X(\Phi(q, X)(t))$, its time derivatives depends in a C^k way of (q, X) . So the map : $(q, X, t) \mapsto \Phi(q, X)(t)$ is C^k .

A.5. The mean curvature map. So for $Z \in \mathcal{Z}^k$, $\mathcal{Y}(Z) \in \mathcal{X}^k$ and the map $\Psi_Z : (p, t) \in B_1 \times [0, 1] \mapsto \Phi(q, \mathcal{Y}(Z))(t) \in V$ is C^k and solves

$$(A.5) \quad \begin{cases} \partial_t \Psi_Z(q, t) = \mathcal{Y}(Z)(\Psi_Z(q, t)) \\ \Psi_Z(q, 0) = (q, 1, 1) \end{cases}$$

The map Ψ_Z is a smooth embedding and we can then define the mean curvature map $\mathcal{H} : \mathcal{G}^k \times \mathcal{Z}^k \times [0, 1] \rightarrow \mathbb{R}$ such that $\mathcal{H}(h, Z, t)$ is the mean curvature of $\Psi_Z(B_1 \times [0, 1])$ at $\Psi_Z(0, t)$ with respect to the metric h and the unit normal that points in the upward direction near $\Psi_Z(0, 0)$ (see Figure 2). Let us notice that, by construction, the map \mathcal{H} is C^2 when $k \geq 4$.

For $r \in \mathbb{R}^{n-2}$ and $s > 0$, we can define the map $J_{r,s} : U \rightarrow \mathbb{R}^{n-2} \times \mathbb{R}_+^2; (q, x, z) \mapsto (r + sq, sx, sz)$. We notice that when r and s are small $J_{r,s}$ maps U into the neighborhood of $\bar{p} = 0$.

We can then define $g_{r,s} = s^{-2}J_{r,s}^*g$. The maps $(r,s) \mapsto g_{r,s}$ extends smoothly when $s = 0$ by a constant metric $g_{r,0} = g(r,0,0)$. So for all s and r small, $g_{r,s}$ is close to $g_{0,0} = g_{\bar{\alpha}} = \delta^2 + dx^2 + 2 \cos \bar{\alpha} dx dz + dz^2$ where δ^2 is the Euclidean metric on \mathbb{R}^{n-2} and $\bar{\alpha} = \alpha(\bar{p})$.

A.6. The metric to gradient of the distance operator. In this subsection, we study the operator that associates to $h \in \mathcal{G}^{2k+1}$, the vector field $\nabla^h \delta_h$ where δ_h is the distance to $\{x = 0\}$ with respect to h .

In order to study this operator, we first solve the geodesic flow for a metric $h \in \mathcal{G}^{2k+1}$ close to $g_{\bar{\alpha}}$ starting orthogonally from a point in $B_3 \times \{0\} \times (\frac{1}{4}, 2+2A)$. For $h \in \mathcal{G}^{2k+1}$, the covariant derivative can be written $\nabla_X^h Y = \nabla_X^0 Y + \Gamma^h(X, Y)$ where ∇^0 is the usual covariant derivative in \mathbb{R}^n and Γ^h is some symmetric tensor field with value in \mathbb{R}^n (notice that Γ^h is C^{2k} if $h \in \mathcal{G}^{2k+1}$). In order to control the existence time of the geodesic, the geodesic won't be parametrized by arc length.

Let $\mathcal{S}^k = \{(F, Y) \in C^k([0, 3], \mathbb{R}^n) \times C^k([0, 3], \mathbb{R}^n) \mid \forall t \in [0, 3], F(t) \in U, F^x(t) = tF^z(t), Y^x(t) > \frac{1}{2} \text{ and } Y^z < \frac{1}{16}\}$ and $T\mathcal{S}^k = \{(F, Y) \in C^k([0, 3], \mathbb{R}^n) \times C^k([0, 3], \mathbb{R}^n) \mid \forall t \in [0, 3], F^x(t) = tF^z(t)\}$. For a metric h and $(q, z) \in B^3 \times (\frac{1}{4}, 2A+2)$, we denote by $N(h, q, z)$ the unit normal vector to $\{x = 0\}$ at $(q, 0, z)$. We then define the map

$$C : \mathcal{G}^{2k+1} \times B_3 \times (\frac{1}{4}, 2+2A) \times \mathcal{S}^k \rightarrow T\mathcal{S}^k \\ (h, q, z, (F, Y)) \mapsto (t \mapsto M(t))$$

where

$$M(t) = \begin{pmatrix} F(t) - (q, 0, z) - \int_0^t \frac{F^z(s)}{Y^x(s) - sY^z(s)} (Y^\top(s) + Y^z(s)\partial_z) ds + t \int_0^t \frac{F^z(s)}{Y^x(s) - sY^z(s)} Y^z(s) \partial_x ds \\ Y(t) - N(h, q, z) + \int_0^t \frac{F^z(s)}{Y^x(s) - sY^z(s)} \Gamma_{F(s)}^h(Y(s), Y(s)) ds \end{pmatrix}$$

Notice that the assumptions on $(F, Y) \in \mathcal{S}^k$ give $Y^x - sY^z > \frac{1}{4}F^z > 0$. The coefficient $\frac{F^z(s)}{Y^x(s) - sY^z(s)}$ and the expression of M ensures that $C(h, q, z, (F, Y))$ belongs to $T\mathcal{S}^k$. Moreover $C(h, q, z, (F, Y)) = 0$ if and only if

$$\begin{cases} \frac{d}{dt} F = \frac{F^z(t)}{Y^x(t) - tY^z(t)} Y(t) \\ F(0) = (q, 0, z) \\ \frac{D^h}{dt} Y = 0 \\ Y(0) = N(h, q, z) \end{cases}$$

in other words, F runs through the geodesic starting from $(q, 0, z)$ in the direction $N(h, q, z)$ and $Y(t)$ is the unit tangent vector to this geodesic at $F(t)$ and F stops when it crosses $\{x = 3z\}$.

For the metric $h = g_\alpha$, let $F_\alpha(q, z, t) = (q, \frac{tz}{1+t \cos \alpha}, \frac{z}{1+t \cos \alpha})$ and recall the notation $X_\alpha = \frac{1}{\sin \alpha}(\partial_x - \cos \alpha \partial_z)$. For $(q, z) \in B_3 \times (\frac{1}{4}, 2+2A)$, $F_\alpha(q, z, \cdot) \in \mathcal{S}^k$ and $C(g_\alpha, q, z, (F_\alpha(q, z, \cdot), X_\alpha)) = 0$ (notice that $\Gamma^{g_\alpha} = 0$). The map C is C^k and the derivative with respect to (F, Y) at $(F_\alpha(q, z, \cdot), X_\alpha)$ is:

$$D_{F,Y}C(g_\alpha, q, z, F_\alpha(q, z, \cdot), X_\alpha) : \begin{matrix} T\mathcal{S}^k & \rightarrow & T\mathcal{S}^k \\ (G, Z) & \mapsto & \left(t \mapsto \begin{pmatrix} G(t) - \int_0^t L(s, G(s), Z(s)) ds \\ Z(t) \end{pmatrix} \right) \end{matrix}$$

where $L : [0, 3] \times \mathbb{R}^n \times \mathbb{R}^n \rightarrow \mathbb{R}^n$ is C^∞ in its first variable and bilinear in the last two. As above, this differential is invertible. So there is a neighborhood \mathcal{N} of $g_{\bar{\alpha}}$ in \mathcal{G}^{2k+1} and a C^k map $\zeta : \mathcal{N} \times B_{5/2} \times (\frac{1}{4}, 2+2A) \rightarrow \mathcal{S}$ such that $C(h, q, z, \zeta(h, q, z)) = 0$. ζ can be written as $\zeta = (\zeta_F, \zeta_Y)$. We have $\zeta_F(g_{\bar{\alpha}}, q, z) = F_{\bar{\alpha}}(q, z, \cdot)$. The map $(q, z, t) \mapsto F_{\bar{\alpha}}(q, z, t)$ is a diffeomorphism from $B_{5/2} \times (\frac{1}{4}, 2+2A) \times [0, 3]$ onto a subset that contains V (actually there are no focal time along any geodesic for $g_{\bar{\alpha}}$) (see Figure 1). As a consequence, $(q, z, t) \mapsto \zeta_F(h, q, z)(t)$ is a diffeomorphism from $B_{5/2} \times (\frac{1}{4}, 2+2A) \times [0, 3]$ onto a subset that contains V for h close to $g_{\bar{\alpha}}$. So, reducing \mathcal{N} , we have a C^k map $\Xi : \mathcal{N} \rightarrow C^k(B_{5/2} \times (\frac{1}{4}, 2+2A) \times [0, 3], \mathbb{R}^n)$ defined by $\Xi(h) : (q, z, t) \mapsto \zeta_F(h, q, z)(t)$ such that $\Xi(h)$ is a diffeomorphism on its image and this image contains V . As a consequence, for any $h \in \mathcal{N}$, the converse map $\Xi(h)^{-1}$ is well defined on V , so

we have a C^k map $\tilde{\Xi} : \mathcal{N} \rightarrow C^k(V, B_{5/2} \times (\frac{1}{4}, 2 + 2A) \times [0, 3])$ such that $\tilde{\Xi}(h) = \Xi(h)^{-1}$. Then, for $h \in \mathcal{N}$, we can define the vector field Z_h on V by $Z_h(p) = \zeta_Y(h, \tilde{\Xi}(h)(p))$ (here we write $\zeta_Y(h, q, z)(t) = \zeta_Y(h, q, z, t)$). By construction, the map $h \in \mathcal{N} \mapsto Z_h$ is C^k and Z_h is a unit vector field tangent to geodesic of h starting orthogonally from $\{x = 0\}$. As a consequence Z_h is the gradient of the distance function δ_h to $\{x = 0\}$ for the metric h .

As a consequence for any r, s small, there is a vector field $X_{r,s}$ which is the gradient of the distance function to $\{x = 0\}$ with respect to $g_{r,s}$. Moreover $(r, s) \mapsto X_{r,s}$ is C^k (for any k).

Recall that we are interested in the sign of the mean curvature of S_{s_n} at p_n . We know that p_n belongs to E so $p_n = \phi_{s_n t_n}(\tilde{p}_n)$ for some $\tilde{p} = (\tilde{q}_n, s_n, s_n)$ and $t_n \in [0, 1]$. Since $p_n \rightarrow \tilde{p}$, $\tilde{p}_n \rightarrow \tilde{p}$ and we can write $\tilde{p}_n = \tilde{p} + r_n$. Since J_{r_n, s_n} is a local homothety of factor s_n from (U, g_{r_n, s_n}) into a neighborhood of the origin in $(\mathbb{R}^{n-2} \times \mathbb{R}_+^2, g)$, the mean curvature of S_{s_n} is then given by $\frac{1}{s_n} \mathcal{H}(g_{r_n, s_n}, X_{r_n, s_n}, t_n)$. So we need to understand the sign of $\mathcal{H}(g_{r,s}, X_{r,s}, t)$ for r, s small and $t \in [0, 1]$. This quantity is continuous in (r, s) so let us first consider the case $(r, s) = (0, 0)$.

A.7. Computation of $\mathcal{H}(g_{\bar{\alpha}}, X_{\bar{\alpha}}, t)$. We consider a slightly more general computation. Let h be a constant metric of the form $h = ds^2 + dx^2 + 2 \cos \bar{\alpha} dx dz + dz^2$ where ds^2 is a scalar product on \mathbb{R}^{n-2} . Let us notice that $\nabla^h \delta_h = X_{\bar{\alpha}}$. Besides a vector field normal (for h) to $\Psi_{X_{\bar{\alpha}}}(B_1 \times [0, 1])$ is given by

$$\psi\left(\frac{x}{z}\right) \frac{-\cos \bar{\alpha} \partial_x + \partial_z}{\sin \bar{\alpha}} + (1 - \psi\left(\frac{x}{z}\right)) \partial_z = -\psi\left(\frac{x}{z}\right) \frac{\cos \bar{\alpha}}{\sin \bar{\alpha}} \partial_x + \left(\frac{\psi\left(\frac{x}{z}\right)}{\sin \bar{\alpha}} + (1 - \psi\left(\frac{x}{z}\right))\right) \partial_z$$

whose norm in the metric h is

$$W = \left(\psi^2\left(\frac{x}{z}\right) + (1 - \psi\left(\frac{x}{z}\right))^2 + 2 \sin \bar{\alpha} \psi\left(\frac{x}{z}\right)(1 - \psi\left(\frac{x}{z}\right))\right)^{1/2}$$

In the following, we will lighten the notations by writing $u = \frac{x}{z}$, $\psi = \psi(u)$ and $\psi' = \psi'(u)$. So the unit normal vector to $\Psi_{X_{\bar{\alpha}}}(B_1 \times [0, 1])$ is given by

$$N = \frac{1}{W} \left((-\psi \frac{\cos \bar{\alpha}}{\sin \bar{\alpha}} \partial_x + (\frac{\psi}{\sin \bar{\alpha}} + (1 - \psi)) \partial_z) \right)$$

We then can compute the mean curvature as the opposite of the divergence of N . We have

$$\begin{aligned} \partial_x W^{-1} &= -\frac{1}{z} \psi' (2\psi - 1) (1 - \sin \bar{\alpha}) W^{-3} \\ \partial_z W^{-1} &= \frac{u}{z} \psi' (2\psi - 1) (1 - \sin \bar{\alpha}) W^{-3} \end{aligned}$$

Thus

$$\begin{aligned} \operatorname{div} N &= \frac{1}{z} \psi' (2\psi - 1) (1 - \sin \bar{\alpha}) W^{-3} \left(\psi \frac{\cos \bar{\alpha}}{\sin \bar{\alpha}} + u \left(\frac{\psi}{\sin \bar{\alpha}} + (1 - \psi) \right) \right) \\ &\quad - \frac{1}{z} \psi' W^{-1} \left(\frac{\cos \bar{\alpha}}{\sin \bar{\alpha}} + u \left(\frac{1}{\sin \bar{\alpha}} - 1 \right) \right) \\ &= \frac{\psi'}{z} \psi' (2\psi - 1) (1 - \sin \bar{\alpha}) W^{-3} \left(\psi \left(\frac{\cos \bar{\alpha}}{\sin \bar{\alpha}} + u \left(\frac{1}{\sin \bar{\alpha}} - 1 \right) \right) + u \right) \\ &\quad - \frac{1}{z} \psi' W^{-1} \left(\frac{\cos \bar{\alpha}}{\sin \bar{\alpha}} + u \left(\frac{1}{\sin \bar{\alpha}} - 1 \right) \right) \\ &= \frac{\psi'}{z} W^{-3} \left(u (2\psi - 1) (1 - \sin \bar{\alpha}) \right. \\ &\quad \left. + \left(\frac{\cos \bar{\alpha}}{\sin \bar{\alpha}} + u \left(\frac{1}{\sin \bar{\alpha}} - 1 \right) \right) (\psi (2\psi - 1) (1 - \sin \bar{\alpha}) - W^2) \right) \\ &= \frac{\psi'}{z} W^{-3} \left(u (2\psi - 1) (1 - \sin \bar{\alpha}) + \left(\frac{\cos \bar{\alpha}}{\sin \bar{\alpha}} + u \left(\frac{1}{\sin \bar{\alpha}} - 1 \right) \right) (\psi (1 - \sin \bar{\alpha}) - 1) \right) \\ &= \frac{\psi'}{z} W^{-3} \mu(\psi) \end{aligned}$$

where μ is some affine function depending on u . So in order to control the sign of μ on $[0, 1]$, we just have to look at

$$\mu(0) = -u(1 - \sin \bar{\alpha}) - \left(\frac{\cos \bar{\alpha}}{\sin \bar{\alpha}} + u \left(\frac{1}{\sin \bar{\alpha}} - 1 \right) \right) < 0 \text{ if } \bar{\alpha} \in (0, \frac{\pi}{2})$$

and

$$\mu(1) = u(1 - \sin \bar{\alpha}) - \sin \bar{\alpha} \left(\frac{\cos \bar{\alpha}}{\sin \bar{\alpha}} + u \left(\frac{1}{\sin \bar{\alpha}} - 1 \right) \right) = -\cos \bar{\alpha} < 0 \text{ if } \bar{\alpha} \in (0, \frac{\pi}{2})$$

Thus we have that the mean curvature vanishes for $\bar{\alpha} = \frac{\pi}{2}$ and has the opposite sign to $\psi'(\frac{x}{z})$ when $\bar{\alpha} \in (0, \frac{\pi}{2})$. Because of the assumptions on ψ , it gives that

$$(A.6) \quad \mathcal{H}(h, X_{\bar{\alpha}}, t) > 0 \iff \bar{\alpha} \in (0, \frac{\pi}{2}) \text{ and } t \neq 0$$

As a consequence, for $h = g_{\bar{\alpha}}$, if $\bar{\alpha} \in (0, \frac{\pi}{2})$ and $t_n \rightarrow \bar{t} \in (0, 1]$, then the mean curvature of S_{s_n} at p_n is positive for large n (and even goes to $+\infty$).

A.8. The case $\bar{t} = 0$. Let us denote $\alpha_n = \alpha(r_n)$, we have

$$\mathcal{H}(g_{r_n, s_n}, X_{r_n, s_n}, t_n) = \mathcal{H}(g_{r_n, s_n}, X_{r_n, s_n}, 0) + \int_0^{t_n} \partial_t \mathcal{H}(g_{r_n, s_n}, X_{r_n, s_n}, s) ds$$

Since \mathcal{H} is C^2 , there is a constant C such that

$$|\partial_t \mathcal{H}(g_{r_n, s_n}, X_{r_n, s_n}, s) - \partial_t \mathcal{H}(g_{r_n, 0}, X_{r_n, 0}, s)| \leq C(|g_{r_n, s_n} - g_{r_n, 0}| + |X_{r_n, s_n} - X_{r_n, 0}|)$$

By definition of $g_{r, s}$, $|g_{r_n, s_n} - g_{r_n, 0}| \leq C s_n$ and $|X_{r_n, s_n} - X_{r_n, 0}| \leq C s_n$ (see A.6, regularity of the map $h \mapsto \nabla^h \delta_h$). This implies that

$$\begin{aligned} \mathcal{H}(g_{r_n, s_n}, X_{r_n, s_n}, t_n) &\geq \mathcal{H}(g_{r_n, s_n}, X_{r_n, s_n}, 0) + \int_0^{t_n} \partial_t \mathcal{H}(g_{r_n, 0}, X_{r_n, 0}, s) ds - C \int_0^{t_n} s_n ds \\ &\geq s_n H(r_n, s_n, s_n) + \mathcal{H}(g_{r_n, 0}, X_{r_n, 0}, t_n) - C t_n s_n \\ &\geq s_n (H(r_n, s_n, s_n) - C t_n) \\ &\geq 0 \quad \text{for large } n \end{aligned}$$

where we use $\mathcal{H}(g_{r_n, 0}, X_{r_n, 0}, t_n) \geq 0$ (see (A.6) and $\alpha(r_n) \in (0, \frac{\pi}{2}]$), H positive and $t_n \rightarrow 0$.

A.9. The case $\bar{\alpha} = \frac{\pi}{2}$. By (A.6), $\mathcal{H}(g_{q_n, 0}, X_{q_n, 0}, t_n) \geq 0$ so, if $\mathcal{H}(g_{q_n, s_n}, X_{q_n, s_n}, t_n) \leq 0$, we have

$$0 \geq \lim_{s_n} \frac{\mathcal{H}(g_{q_n, s_n}, X_{q_n, s_n}, t_n) - \mathcal{H}(g_{q_n, 0}, X_{q_n, 0}, t_n)}{s_n}$$

Since \mathcal{H} is C^1 , this limit is

$$D_h \mathcal{H}(g_{0,0}, \partial_x, \bar{t}) \left(\frac{\partial}{\partial s} g_{0,s} \Big|_{s=0} \right) + D_X \mathcal{H}(g_{0,0}, \partial_x, \bar{t}) \left(\frac{\partial}{\partial s} X_{0,s} \Big|_{s=0} \right)$$

So we have to compute the two above terms. We have

$$\begin{aligned} D_h \mathcal{H}(g_{0,0}, \partial_x, \bar{t}) \left(\frac{\partial}{\partial s} g_{0,s} \Big|_{s=0} \right) &= \frac{\partial}{\partial s} \mathcal{H}(g_{0,s}, \partial_x, \bar{t}) \Big|_{s=0} \\ &= \frac{\partial}{\partial s} (sH(0, s(1 - \bar{t}), s)) \Big|_{s=0} = H(0) \end{aligned}$$

For the second term, let us study $D_X \mathcal{H}(g_{0,0}, \partial_x, \bar{t})$. Let Y be a vector field in V such that $Y^z = 0$. Thus, for any s , $\partial_x + sY$ and $\mathcal{Y}(\partial_x + sY)$ has no component in the ∂_z direction. Thus $\mathcal{H}(g_{0,0}, \partial_x + sY, \bar{t})$ is just the mean curvature of $\{z = 1\}$ for the metric $g_{0,0}$ so it vanishes. Thus $D_X \mathcal{H}(g_{0,0}, \partial_x, \bar{t})(Y) = 0$. Hence we may focus on the ∂_z component of $\bar{Y} = \frac{\partial}{\partial s} X_{0,s} \Big|_{s=0}$.

First let us notice that

$$\frac{\partial}{\partial s} g_{0,s} \Big|_{s=0}(q, x, z) = D_q g(0)(q) + D_x g(0)x + D_z g(0)z$$

Let us denote by k the above symmetric tensor. In order to compute \bar{Y} , let us remark that if Z_h is the gradient of the distance associated to the metric h , we have, on V_0 ,

$$\begin{cases} h(Z_h, Z_h) = 1 \\ h(Z_h, \partial_z) = 0 \\ h(Z_h, \partial_i) = 0 \quad \text{for all } 1 \leq i \leq n-2 \end{cases}$$

and, on V , $\nabla_{Z_h}^h Z_h = 0$. So differentiating these equalities with respect to s , for $h = g_{0,s}$, gives

$$(A.7) \quad k(\partial_x, \partial_x) + 2g_{0,0}(\bar{Y}, \partial_x) = 0 \text{ on } V_0$$

$$(A.8) \quad k(\partial_x, \partial_z) + g_{0,0}(\bar{Y}, \partial_z) = 0 \text{ on } V_0$$

$$(A.9) \quad k(\partial_x, \partial_i) + g_{0,0}(\bar{Y}, \partial_i) = 0 \text{ on } V_0 \text{ and } 1 \leq i \leq n-2$$

$$(A.10) \quad \Gamma(k)(\partial_x, \partial_x) + \nabla_{\partial_x}^{g_{0,0}} \bar{Y} = 0 \text{ in } V$$

where $\Gamma(k)(\partial_x, \partial_x) = \sum_m (\partial_x k_{xm} - \frac{1}{2} \partial_m k_{xx}) \partial_m$. Let us remark that $\Gamma(k)(\partial_x, \partial_x)$ is a constant vector field in V . Its component along ∂_z is given by

$$(\partial_x g(\partial_x, \partial_z) - \frac{1}{2} \partial_z g(\partial_x, \partial_x))|_{p=0} = g(\nabla_{\partial_x} \partial_x, \partial_z)|_{p=0}$$

So, in order to evaluate the component \bar{Y}^z , we just have to know it along V_0 . Let us first remark that, since $\alpha(0) = \frac{\pi}{2}$ is a maximum value of α , we have $D_q \alpha(0) = 0$ and thus $D_q g(0)$ has a vanishing xz component. Thus, on V_0 , $k(\partial_x, \partial_z) = z \partial_z g(\partial_x, \partial_z)|_{p=0}$ and, by (A.8), $\bar{Y}^z = -z g(\partial_x, \partial_z)|_{p=0}$ along V_0 . Let us denote by $b = \partial_z g(\partial_x, \partial_z)|_{p=0}$ and $a = g(\nabla_{\partial_x} \partial_x, \partial_z)|_{p=0}$. Thus (A.10) gives $\bar{Y}^z = -ax - bz$. So the question is then to compute

$$D_X \mathcal{H}(g_{0,0}, \partial_x, \bar{t})((-ax - bz)\partial_z)$$

we have

$$\mathcal{Y}(\partial_x - s(ax + bz)\partial_z) = -\partial_x + s(1 - \psi)(ax + bz)\partial_z$$

A vectorfield normal to the associated hypersurface is given by

$$s(1 - \psi)(ax + bz)\partial_x + \partial_z$$

whose norm is given by

$$W = (1 + s^2(1 - \psi)^2(ax + bz)^2)^{1/2}$$

So the unit normal is given by

$$N = \frac{1}{W}(s(1 - \psi)(ax + bz)\partial_x + \partial_z) = \partial_z + s(1 - \psi)(ax + bz)\partial_x + O(s^2)$$

Thus

$$\begin{aligned} \operatorname{div} N &= s \left(-\frac{1}{z} \psi'(ax + bz) + (1 - \psi)a \right) + O(s^2) \\ &= -s(\psi'(au + b) - (1 - \psi)a) + O(s^2) \end{aligned}$$

So the derivative with respect to s is given by $-(\psi'(au + b) - (1 - \psi)a)$. Thus the sign of $D_X \mathcal{H}(g_{0,0}, \partial_x, \bar{t})((-ax - bz)\partial_z)$ is the one of $\psi'(au + b) - (1 - \psi)a$. This expression is non-negative if

$$b \geq \left(\frac{1 - \psi}{\psi'} - u \right) a$$

Notice that ψ can be chosen such that $\frac{1 - \psi}{\psi'} - u$ is bounded on $[0, 1]$ (take $\psi(u) = 1 - \exp(-1/(u - 1)^2)$ near 1). Now by the coordinate improvement (A.1), the above inequality can be assumed to be true.

Finally this implies that

$$D_h \mathcal{H}(g_{0,0}, \partial_x, \bar{t}) \left(\frac{\partial}{\partial s} g_{0,s}|_{s=0} \right) + D_X \mathcal{H}(g_{0,0}, \partial_x, \bar{t}) \left(\frac{\partial}{\partial s} X_{0,s}|_{s=0} \right) \geq H(0) > 0$$

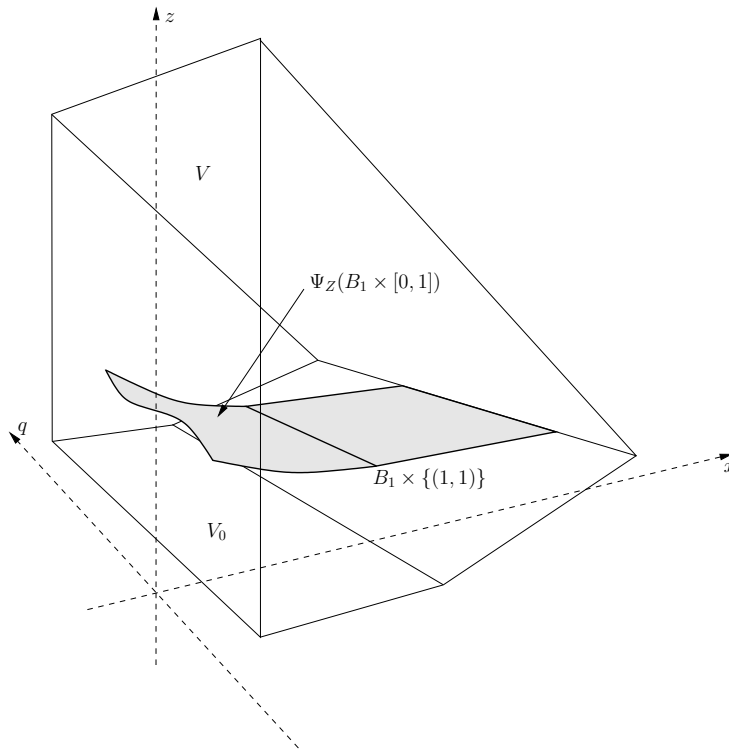
FIGURE 2. The hypersurface S_s in V

contradicting $\mathcal{H}(g_{q_n, s_n}, X_{q_n, s_n}, t_n) \leq 0$. We then have proved that the mean curvature of S_s is positive for small s and have finished the proof of Proposition A.1.

REFERENCES

1. Lucas C. Ambrozio, *Rigidity of area-minimizing free boundary surfaces in mean convex three-manifolds*, J. Geom. Anal. **25** (2015), 1001–1017.
2. Guy Barles, *An introduction to the theory of viscosity solutions for first-order Hamilton-Jacobi equations and applications*, Hamilton-Jacobi equations: approximations, numerical analysis and applications, Lecture Notes in Math., vol. 2074, Springer, Heidelberg, 2013, pp. 49–109.
3. Arthur L. Besse, *Einstein manifolds*, Classics in Mathematics, Springer-Verlag, Berlin, 2008, Reprint of the 1987 edition.
4. Hubert Bray, Simon Brendle, and Andre Neves, *Rigidity of area-minimizing two-spheres in three-manifolds*, Comm. Anal. Geom. **18** (2010), 821–830.
5. Alessandro Carlotto, Giada Franz, and Mario B. Schulz, *Free boundary minimal surfaces with connected boundary and arbitrary genus*, Camb. J. Math. **10** (2022), 835–857.
6. Tobias H. Colding and Camillo De Lellis, *The min-max construction of minimal surfaces*, Surveys in differential geometry, Vol. VIII (Boston, MA, 2002), Surv. Differ. Geom., VIII, Int. Press, Somerville, MA, 2003, pp. 75–107.
7. Michael G. Crandall, Hitoshi Ishii, and Pierre-Louis Lions, *User's guide to viscosity solutions of second order partial differential equations*, Bull. Amer. Math. Soc. (N.S.) **27** (1992), 1–67.
8. Camillo De Lellis and Filippo Pellandini, *Genus bounds for minimal surfaces arising from min-max constructions*, J. Reine Angew. Math. **644** (2010), 47–99.
9. Manfredo Perdigão do Carmo, *Riemannian geometry*, Mathematics: Theory & Applications, Birkhäuser Boston, Inc., Boston, MA, 1992, Translated from the second Portuguese edition by Francis Flaherty.
10. Giada Franz, *Equivariant index bound for min-max free boundary minimal surfaces*, preprint, arXiv:2110.01020.

11. Giada Franz and Mario B. Schulz, *Topological control for min-max free boundary minimal surfaces*, preprint, arXiv:arXiv:2307.00941.
12. Ailana Fraser and Martin Man-chun Li, *Compactness of the space of embedded minimal surfaces with free boundary in three-manifolds with nonnegative Ricci curvature and convex boundary*, *J. Differential Geom.* **96** (2014), 183–200.
13. Jean Gallier and Dianna Xu, *A guide to the classification theorem for compact surfaces*, *Geometry and Computing*, vol. 9, Springer, Heidelberg, 2013.
14. David Gilbarg and Neil S. Trudinger, *Elliptic partial differential equations of second order*, *Classics in Mathematics*, Springer-Verlag, Berlin, 2001, Reprint of the 1998 edition.
15. P. Grisvard, *Elliptic problems in nonsmooth domains*, *Monographs and Studies in Mathematics*, vol. 24, Pitman (Advanced Publishing Program), Boston, MA, 1985.
16. M. Gromov, *Dimension, nonlinear spectra and width*, *Geometric aspects of functional analysis (1986/87)*, *Lecture Notes in Math.*, vol. 1317, Springer, Berlin, 1988, pp. 132–184.
17. M. Grüter and J. Jost, *On embedded minimal disks in convex bodies*, *Ann. Inst. H. Poincaré Anal. Non Linéaire* **3** (1986), 345–390.
18. Qiang Guang, Zhichao Wang, and Xin Zhou, *Free boundary minimal hypersurfaces with least area*, preprint, arxiv:1801.07036.
19. Robert Haslhofer and Daniel Ketover, *Free boundary minimal disks in convex balls*, preprint, arXiv:2307.01828.
20. Jürgen Jost, *Existence results for embedded minimal surfaces of controlled topological type. II*, *Ann. Scuola Norm. Sup. Pisa Cl. Sci. (4)* **13** (1986), 401–426.
21. Hermann Karcher, *Riemannian comparison constructions*, *Global differential geometry*, *MAA Stud. Math.*, vol. 27, Math. Assoc. America, Washington, DC, 1989, pp. 170–222.
22. Daniel Ketover, *Free boundary minimal surfaces of unbounded genus*, preprint, arXiv:1612.08691.
23. Martin Man-chun Li, *A general existence theorem for embedded minimal surfaces with free boundary*, *Comm. Pure Appl. Math.* **68** (2015), 286–331.
24. Fernando C. Marques and André Neves, *Rigidity of min-max minimal spheres in three-manifolds*, *Duke Math. J.* **161** (2012), 2725–2752.
25. Laurent Mazet, *Rigidity of riemannian manifolds containing an equator*, arXiv:2010.01994.
26. Abraão Mendes, *Rigidity of free boundary surfaces in compact 3-manifolds with strictly convex boundary*, *J. Geom. Anal.* **28** (2018), 1245–1257.
27. Robert C. Reilly, *Applications of the Hessian operator in a Riemannian manifold*, *Indiana Univ. Math. J.* **26** (1977), 459–472.
28. F. Smith, *On the existence of embedded minimal 2-spheres in a 3-sphere, endowed with an arbitrary Riemannian metric*, Ph.D. thesis, University of Melbourne, 1982, Supervisor : Leon Simon.
29. Changyu Xia, *Rigidity of compact manifolds with boundary and nonnegative Ricci curvature*, *Proc. Amer. Math. Soc.* **125** (1997), 1801–1806.

INSTITUT DENIS POISSON, CNRS UMR 7013, UNIVERSITÉ DE TOURS, UNIVERSITÉ D'ORLÉANS, PARC DE GRANDMONT, 37200 TOURS, FRANCE

Email address: laurent.mazet@univ-tours.fr

INSTITUTO DE MATEMÁTICA, UNIVERSIDADE FEDERAL DE ALAGOAS, MACEIÓ, AL, BRAZIL

Email address: abraao.mendes@im.ufal.br