



HAL
open science

Online Large-Scale Taxi Assignment: Optimization and Learning

Omar Rifki, Thierry Garaix

► **To cite this version:**

Omar Rifki, Thierry Garaix. Online Large-Scale Taxi Assignment: Optimization and Learning. Findings, 2023, 10.32866/001c.74765 . hal-04116309

HAL Id: hal-04116309

<https://hal.science/hal-04116309v1>

Submitted on 13 Jul 2023

HAL is a multi-disciplinary open access archive for the deposit and dissemination of scientific research documents, whether they are published or not. The documents may come from teaching and research institutions in France or abroad, or from public or private research centers.

L'archive ouverte pluridisciplinaire **HAL**, est destinée au dépôt et à la diffusion de documents scientifiques de niveau recherche, publiés ou non, émanant des établissements d'enseignement et de recherche français ou étrangers, des laboratoires publics ou privés.

Online Large-Scale Taxi Assignment: Optimization and Learning

Omar Rifki¹ and Thierry Garaix²

¹Univ. Littoral Cote d'Opale, LISIC, F-62100 Calais, France. rifki@univ-littoral.fr
²Mines Saint-Etienne, Univ Clermont Auvergne, CNRS, UMR 6158 LIMOS, Centre CIS,
Departement I4S, F-42023, Saint-Etienne, France. garaix@emse.fr

March 2023

Abstract

We propose a solution method for online vehicle routing, which integrates a machine learning routine to improve tours' quality. Our optimization model is based on the Bertsimas et al. (2019) re-optimization approach. Two separate routines are developed. The first one uses a neural network to produce realistic pick-up times for the customers to serve. The second one relies on Q-learning in addition to random walks for the construction of the backbone graph corresponding to the instance problem of each time step. The second routine gives improved results compared to the original approach. The considered benchmark dataset is the same as that of Bertsimas et al. (2019).

Keywords: online vehicle routing, taxis, Q-learning, neural networks, mixed-integer optimization, simulation.

1 Questions

More optimization solvers opt for machine learning (ML) integration in order to take advantage of pattern recognition in the search for solutions (Bengio et al., 2021; Karimi-Mamaghan et al., 2022). Online optimization¹ poses several challenges for this integration to happen, such as the change of the problem structure across the optimization periods, plus the duration of the period or the time step, which could be very short to perform learning. In online vehicle routing problems (Jaillet & Wagner, 2008), this issue can happen for instance, in case the vehicles' locations and the customers' requests are revealed over time. We study the online taxi problem as defined by Bertsimas et al. (2019), where the transportation requests issued from customers are revealed a number of minutes before their pick-up time and their assignment to taxis has to be acknowledged within minutes before. This is a special case of the online vehicle routing problem (see Appendix A for a formal definition). Their approach manages to solve the online taxi problem for a large demand: about 600-6500 customers for each re-optimization which lasts 30 seconds in the area of Manhattan. It offers then a good starting point to test the optimization-ML integration in a dynamic context. Our basic idea is to design ML routines within the re-optimization in order to improve the quality of the constructed tours. We show that learning can happen even in the case of tight time steps.

2 Methods

The re-optimization of Bertsimas et al. (2019) relies on a great simplification of the working graph of the problem with the aim to make the resolution more tractable for each time step. The formal problem definition and their proposed approach are presented in Appendix A. The first ML routine that we implemented is based on the neural network structure. Because of its poor results, this method is only detailed in Appendix B.

Our second ML routine uses reinforcement learning on the working graph to construct the paths of taxis, in addition to using random paths. This routine replaces steps 2 through 7 of Algorithm 1 (see Appendix A), with random paths and paths constructed with the Q-learning algorithm (Watkins

¹Online optimization is a field of optimization theory for which the input data of the problem are revealed over time and decisions have to be given in between.

& Dayan, 1992) on the KG graph². Both types of paths start from the current positions of the taxis, as shown in the example of Figure 1. Once a total of E_{max} arcs are chosen from KG , the MIPmaxflow is solved on this constructed graph. This procedure is done iteratively. Learning for each agent taxi is performed across the different iterations of MIPmaxflow within one time step through Q-learning. The main parameter of the routine is the percentage $p_{rl} \in [0, 1]$ of taxis that construct their paths using learning. These agents are chosen from all taxis in the first iteration in a random way, as follows:

- i/ perform random walks starting from all taxis,
- ii/ solve MIPmaxflow for this selection, and
- iii/ choose the $p_{rl} \times 100$ taxis which have the largest rewards,

By this way, we can concentrate learning on the seemingly most favorable taxis. Random walks are taken to be non-backtracking in this routine. The description of the steps of the routine is shown in Algorithm 1. As you may notice, no solving of maxFlow is performed.

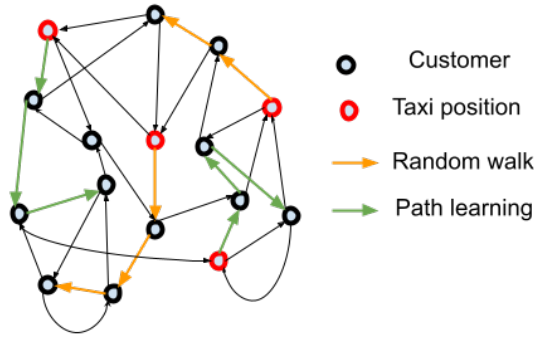

Figure 1: An example of taxi path building on a $2G$ graph.

The state space of Q-learning represents the set of nodes of G : $\mathcal{S} = V$. The current state of each agent taxi is its current node. If a given agent taxi is in a vertex with no outgoing neighbor, it stops exploring, otherwise,

²A pruned graph of the working graph of the problem G (see Appendix A for a definition of KG , MIPmaxflow and maxFlow problems).

it chooses a neighbor according to the Q-table. All the agents explore their neighborhoods in a sequential way. The reward of each agent taxi is given at the end of each iteration in step number 10, by the reward computed for each taxi from the MIPmaxflow resolution. Thus, the reward of each agent taxi depends on the choices of the remaining agents. Setting a state space $\mathcal{S} = V^T$, where each agent accounts for all other agents' current positions is time-consuming. Thus, we did not account for it, given the limited time allowed for optimization in a time step.

Algorithm 1 Q-learning routine

Input: The graph G , the parameter K , a starting solution s , and the probability of agent taxis p_{rl} .

Output: A solution for the current time step

- 1: **while** time is available **do**
 - 2: **First iteration:** Fix the agent taxis T using p_{rl} ;
 - 3: Initialize the backbone graph BG by removing all arcs KG ;
 - 4: Add solution s to BG ;
 - 5: **while** BG has less than $E_{max} \times (1 - p_{rl})$ arcs **do**
 - 6: For each taxi t not in T , generate a random walk on KG from t ;
 - 7: Add those arcs to BG ;
 - 8: **end while**
 - 9: All agents choose their actions (paths) using Q-learning to complete E_{max} arcs in BG ;
 - 10: Solve MIPmaxflow on BG ;
 - 11: Update the solution s ;
 - 12: **end while**
-

Concerning the implementation of the Q-learning policy, we use Monte Carlo methods to estimate the state-action value. For the exploration strategy, we use the epsilon-greedy method with a parameter $\epsilon = 0.1$.

For comparison matters, we consider the case with only random walks $p_{rl} = 0$, denoted RW-based routine.

3 Findings

Results of Table 1 rely on the Bertsimas et al. (2019) dataset, which is based on the demand for taxis on the Manhattan network³. More details on the construction of the dataset and the implementation are provided in Appendix C. We set the simulation time to 20 minutes, and $E_{max} = 2000$. The maximum request times $T_{max}^{request}$, the number of taxis $\#taxi$, and the time step T^{reop} are varied as in the table below. For each customer c , the request time $t_c^{request}$ is uniformly picked within the interval $[t_c^{min} - T_{max}^{request}, t_c^{min}]$. The time allowed for re-optimization in each time step is equal to the half of T^{reop} , meaning that if $T^{reop} = 5min$, only $2.5min$ is allowed to construct the solution, the remaining time is reserved to transfer the new actions to the taxis. We fix $p_{rl} = 10\%$. In the table, $\#nser$ designates the number of not served customers in each simulation.

Input parameters			Backbone-based		Q-learning		RW-based		RNN-based	
$\#taxi$	$T_{max}^{request}$	T^{reop}	$\#nser$	Profits (\$)	$\#nser$	Gain profit (%)	$\#nser$	Gain profit (%)	$\#nser$	Gain profit (%)
5000	5min	1min	19	48104.9	14	+0.14	14	+0.14	1071	-23.93
		5min	402	43879.3	196	+5.03	201	+4.90	4256	-102.84
	10min	1min	250	46375.4	291	-0.84	357	-2.03	893	-16.26
		5min	621	42853.6	451	+3.31	513	+1.86	4256	-102.92
3000	5min	1min	857	41698.4	866	-0.94	891	-1.68	1744	-28.0
		5min	1147	38326.5	1105	+0.79	1138	-0.27	4256	-101.95
	10min	1min	845	41738.7	851	-0.77	861	-1.14	1742	-28.11
		5min	1173	38092.2	1131	+1.11	1135	+0.29	4256	-101.97
2000	5min	1min	83	48164.9	81	+0.08	91	+0.07	1979	-44.17
		5min	645	41721.4	585	+1.58	581	+1.61	4256	-101.2
	10min	1min	366	46280.3	381	-0.57	443	-1.76	1681	-34.59
		5min	738	42316.7	728	-0.4	726	-0.31	4256	-101.18

Table 1: Results of simulation by varying $\#taxi$, $T_{max}^{request}$, and T^{reop} .

These results show that Q-learning subroutine approach offers higher gaps of profits than the RNN routine, surpassing (Bertsimas et al., 2019) approach in the following cases: i/ when the re-optimization time step is larger than 1min, but can be still considered small (5min), and ii/ when the supply of transport is large compared to the demand (5000 taxis). The explanation behind the changes of $\#nser$ in function of $\#taxi$, $T_{max}^{request}$ and T^{reop} is given

³The Julia libraries Flux.jl (Innes, 2018) and ReinforcementLearning.jl (Tian & other contributors, 2020) are used for the implementation.

in Appendix D. The data of Manhattan taxi requests are characterized by a large traffic demand and a large supply of taxis. Any improvement of only 1% of the profit gains can be translated into thousands of US dollars over the day. Compared to the random walks subroutine, the Q-learning subroutine produces higher profit gaps, suggesting that the effect of reinforcement learning is mostly positive. Figure 2 displays the average number of optimizations in a time step for the four approaches.

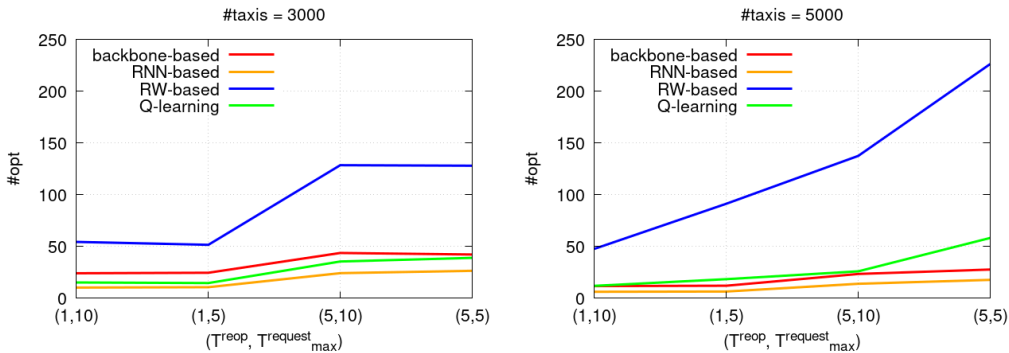

Figure 2: Average number of optimizations in one time step ($\#opt$).

ACKNOWLEDGMENTS

We would like to thank unknown referees for their comments. This research was funded by the project FITS -“Flexible and Intelligent Transportation Systems” (ANR-18-CE22-0014) operated by the French National Research Agency (ANR).

References

- Alom, M. Z., Taha, T. M., Yakopcic, C., Westberg, S., Sidike, P., Nasrin, M. S., ... Asari, V. K. (2019). A state-of-the-art survey on deep learning theory and architectures. *electronics*, 8(3), 292.
- Bengio, Y., Lodi, A., & Prouvost, A. (2021). Machine learning for combinatorial optimization: a methodological tour d’horizon. *European Journal of Operational Research*, 290(2), 405–421.

- Bertsimas, D., Jaillet, P., & Martin, S. (2019). Online vehicle routing: The edge of optimization in large-scale applications. *Operations Research*, 67(1), 143–162.
- Innes, M. (2018). Flux: Elegant machine learning with julia. *Journal of Open Source Software*. doi: 10.21105/joss.00602
- Jaillet, P., & Wagner, M. R. (2008). Online vehicle routing problems: A survey. *The Vehicle Routing Problem: Latest Advances and New Challenges*, 221–237.
- Karimi-Mamaghan, M., Mohammadi, M., Meyer, P., Karimi-Mamaghan, A. M., & Talbi, E.-G. (2022). Machine learning at the service of meta-heuristics for solving combinatorial optimization problems: A state-of-the-art. *European Journal of Operational Research*, 296(2), 393–422.
- Tian, J., & other contributors. (2020). *Reinforcementlearning.jl: A reinforcement learning package for the julia programming language*. Retrieved from <https://github.com/JuliaReinforcementLearning/ReinforcementLearning.jl>
- Watkins, C. J., & Dayan, P. (1992). Q-learning. *Machine learning*, 8, 279–292.

A. Supplementary materials: Model

The taxi problem is a special case of the dial-a-ride problems, where vehicles are allowed to serve only one customer at a time. In the online context, each customer $c \in \mathcal{C}$ has a request time $t_c^{request}$, a confirmation time $t_c^{conf} > t_c^{request}$, when the optimizer confirms to c whether his request is accepted or not, and a pick-up time window $I_c = [t_c^{min}, t_c^{max}]$.

Bertsimas et al. (2019) model the problem as a directed graph $G(V, E)$ where the nodes represent the customers $c \in \mathcal{C}$ and the current positions of the taxis $k \in \mathcal{K}$. Each arc (c', c) has an associated profit $R_{c',c}$, which is equal to the fare paid by the customer c to satisfy minus the cost of driving from the drop-off point of c' , or from the position of the taxi in case of arc (k, c) and c is the first customer visited by the taxi k . The main assumption of the model is that the working graph G has no cycle. This is made possible by deleting arcs

that do not satisfy the time windows of the customers in addition to other tighter time constraints. It is important to notice that the shorter the time windows are, the fewer cycles exist in G . The objective of the optimization is to maximize the total profit of the solution. Without sub-tours elimination, the routing problem becomes a network max-flow problem, with integer and real-valued variables. The mixed integer programming formulation of the offline problem, *i.e.* $t_c^{request} = 0, \forall c \in \mathcal{C}$, is as follows.

$$\max_{x,y,p_c,t_c} \sum_{k \in \mathcal{K}, c \in \mathcal{C}} R_{k,c} y_{k,c} + \sum_{c', c \in \mathcal{C}} R_{c',c} x_{c',c} \quad (1)$$

$$\text{s.t. } p_c = \sum_{k \in \mathcal{K}} y_{k,c} \quad \forall c \in \mathcal{C} \quad (2)$$

$$\sum_{c \in \mathcal{C}} x_{c',c} \leq p_{c'} \quad \forall c' \in \mathcal{C} \quad (3)$$

$$\sum_{c \in \mathcal{C}} y_{k,c} \leq 1 \quad \forall k \in \mathcal{K} \quad (4)$$

$$x_{c',c} \in \{0, 1\} \quad \forall c', c \in \mathcal{C} \quad (5)$$

$$y_{k,c} \in \{0, 1\} \quad \forall k \in \mathcal{K}, \forall c \in \mathcal{C} \quad (6)$$

$$p_c \in \{0, 1\} \quad \forall c \in \mathcal{C} \quad (7)$$

$$t_c^{min} \leq t_c \leq t_c^{max} \quad \forall c \in \mathcal{C} \quad (8)$$

$$t_c \geq t'_c + (t_c^{min} - t_{c'}^{max}) + (T_{c',c} - (t_c^{min} - t_{c'}^{max}))x_{c',c} \quad \forall c', c \in \mathcal{C} \quad (9)$$

$$t_c \geq t_c^{min} + (t_k^{init} + T_{k,c} - t_c^{min})y_{k,c} \quad \forall k \in \mathcal{K}, \forall c \in \mathcal{C} \quad (10)$$

$T_{c',c}$ designates the travel time to serve c' and to drive to the pick-up location of c . The decision variables $y_{k,c}$ and $x_{c,c'}$ specify the order of visit of the customers for each taxi, while p_c tells if customer c is served or not, and t_c provides the pick-up time of c . This problem is denoted **MIPmaxFlow**. When the customers' pick-up times are fixed, the max-flow problem, *i.e.* (1)-(7), becomes efficiently solvable through the simplex algorithm, thanks to some integrality results (see Theorem 1. of Bertsimas et al. (2019)). We denote this subproblem **maxFlow**.

The approach of Bertsimas et al. (2019) to solve the online version consists of solving MIPmaxFlow in each time step for customers with known request times, or in other terms with $t_c^{request} \leq kT^{reopt}$, such that T^{reopt} is the time step duration, and kT^{reopt} corresponds to the starting time of the current re-optimization. To scale the optimization to the real-world high demands

scenario, the authors adopt the routine described in Algorithm 2. At first, the graph G containing the current customers and the current taxi positions is pruned into a graph KG , by selecting the K best incoming and outgoing arcs of each node of G in terms of lost times, which are defined as waiting times plus times of a taxi driving empty. Then, a backbone graph BG is constructed iteratively by solving maxFlow problem on uniformly generated pick-up times, before solving MIPmaxflow on the constructed graph. This step is done repeatedly. The parameters E_{max} and K are chosen such that MIPmaxflow and maxFlow are solvable in reasonable times. More complete details of the model and the algorithm choices are found in Bertsimas et al. (2019).

Algorithm 2 backbone-based routine

Input: The graph G , the parameter K , the limit number E_{max} , and a starting solution s (could be empty)

Output: A solution for the current time step

- 1: Compute KG ;
 - 2: **while** time is available **do**
 - 3: Initialize the backbone graph BG by removing all arcs of KG ;
 - 4: **while** BG has less than E_{max} arcs **do**
 - 5: For each customer c , generate uniformly a pick-up time t_c from I_c or from I_c^s (is the time window where the solution s is propagated in I_c);
 - 6: Solve maxFlow on KG with the t_c pick-up times of the customers;
 - 7: Add the optimal arcs of the solution to the graph BG ;
 - 8: **end while**
 - 9: Solve MIPmaxflow on BG ;
 - 10: Update the solution s ;
 - 11: **end while**
-

B. Supplementary materials: RNN routine

This ML routine has the goal to learn the most adequate pick-up times of the customers, and then solve maxFlow problem for these times. We choose the Recurrent Neural Network (RNN) for the architecture, which is a neural network well suited to manage vector sequences over time (Alom et al., 2019).

The routine replaces steps 3 to 10 of Algorithm 2. Instead of randomly

generating pick-up times (step 5) and solving the maxFlow problem for these times (step 6) for the construction of the support backbone graph (stage 7), we learn the pick-up times of the customers and solve maxFlow problem for these optimal times. No solving of MIPmaxflow is involved. The description of the steps is shown in Algorithm 3. The obtained solution updates the current solution similarly to Algorithm 2.

Algorithm 3 RNN-based routine

Input: The graph G , the parameter K , and a starting solution s (could be empty)

Output: A solution for the current time step

- 1: Compute KG ;
 - 2: **while** time is available **do**
 - 3: **while** exploration time is available **do**
 - 4: For each customer c , generate uniformly a pick-up time $t_c \in I_c$ or $t_c \in I_c^s$;
 - 5: Solve maxFlow on KG with t_c pick-up times of customer;
 - 6: Add the arc profits of the solution to features X and (t_c) to y ;
 - 7: **end while**
 - 8: Train the RNN model m using X and y ;
 - 9: Generate times by $\mathbf{t} = m([R_{e_1}, \dots, R_{|E|}]')$;
 - 10: Solve maxFlow with times \mathbf{t} ;
 - 11: Update the solution s ;
 - 12: **end while**
-

For the training of the RNN, we solve maxFlow with pick-up times uniformly chosen at random within customers' time windows. We also include in the training the times corresponding to the upper bounds of the time windows. The RNN outputs the customers' pick-up times and takes for inputs the solution of the corresponding maxFlow problem, which is in our case a vector over the graph arcs such that if an arc belongs to the solution, its profit value ($R_{e',c}$ or $R_{k,c}$) is taken, otherwise zero. A scheme of RNN is shown in Figure 3. We obtain the learned pick-up times of the current re-optimization by taking as input the profits of all the arcs of the graph KG . Regarding the RNN architecture, we use the sigmoid activation function, plus the cross entropy loss function and the Adam optimizer. According to our tests, tuning across other RNN hyperparameters does not improve the result of the RNN routine. We set the exploration time here (the step 3 of Algorithm 3) to two

third of the time allowed for optimization in each time step.

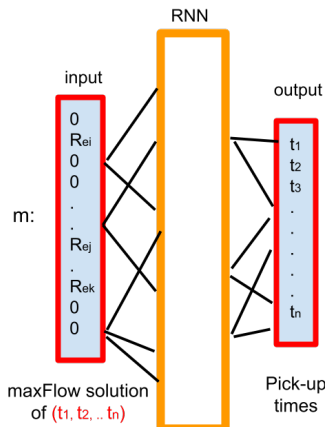

Figure 3: Architecture of the RNN.

C. Supplementary materials: Data

The data consists of several elements. The first element is the demands of the customers, which come from the taxi-trip dataset of the New York City Taxi and Limousine Commission on the area of the Manhattan network. It is constructed by filtering requests with pick-up and drop-off points located in Manhattan. For each customer, t_c^{min} is set to the real pick-up time, $t_c^{max} = t_c^{min} + 5min$, and $t_c^{conf} = t_c^{min} - 4min$. The request time $t_c^{request}$ is a variable of the simulation. Bertsimas et al. (2019) use the demands of Yellow Cabs alone on a specific day, which is 04/15/2016. We use the same inputs.

The second element is the travel times in the Manhattan network. Bertsimas et al. (2019) use the Yellow Cabs data to estimate those times. Having no access to this data, we set travel times according to OpenStreetMap (OSM) in the following way. For each road segment, we set the speed to the maximum speed given by OSM. In the following step for the simplification of the network, if two or more segments are merged, we set the speed to the minimum of the merged segments' speeds. This allows us to considerably reduce the speed in the network since taking the maximum speed is not a reasonable assumption. The shortest path computation uses travel times computed using those speeds. For the profit computation, we use the customer's real

fare set with costs taken proportional to the trip travel times: a cost of 5\$ per hour of driving and a cost of 1\$ per hour of waiting, same as Bertsimas et al. (2019).

The approaches that are compared in Table 1 share the same input data for each simulation run : the same travel times and request times $t_c^{request}$. In order to run Bertsimas et al. (2019)'s program, we convert their Julia source code from version 0.5 to a stable version ≥ 1.0 .

D. Supplementary materials: Demand/supply balance

The quality of the solutions, thus the profits and the number of not served customers, changes according to the number of taxis. With 2000 taxis (and $(T_{max}^{request}, T^{reop}) = (5, 1)$), the solution covers 18% more transportation requests than that of 3000 taxis (and $(T_{max}^{request}, T^{reop}) = (5, 1)$), due to a better-performing arc selection procedure for the backbone graph (steps 4-8 in Algorithm 2; steps 5-9 in Algorithm 1). This is because all problems share the same value of the maximum number of arcs $E_{max} = 2000$. This latter value is taken to make the MIPmaxFlow optimization possible in a short duration. If the number of taxis increases, the selection of arcs is altered. With 5000 taxis, the excess of vehicles makes it possible to correct the lack of coverage with 4000 and 3000 taxis. There is almost always a free taxi able to serve a new customer request. Thus, the solutions' profits become in the same range of the case of 2000 taxis. Notice that the number of not served customers increases as the time step T^{reop} and/or the maximum request times $T_{max}^{request}$ increase, since more customers are present in MIPmaxFlow optimizations compared to the base case of $(T_{max}^{request}, T^{reop}) = (5, 1)$.